

# FARM AND FIRESIDE

THE NATIONAL FARM PAPER



ESTABLISHED  
1877

JULY 10  
1911



Headwork Shop Again Next Issue—Look for It

# Ann Arbor

**It Isn't the Price that Makes the "Ann Arbor" Cheap—It's the Volume of Work It Does**

Just a year ago we published the story of how L. Evans, Toppenshin, Washington, broke the world's record for baling hay by baling 73 tons in 10 hours. Farmers everywhere smiled and it was made a record. They thought it was mighty good—but Evans and his crew did just as well again last season.

And, Ann Arbor users everywhere—by trying to equal the record, increased their profits; they found by a little study and a little systemizing of their work, they could get more money out of the same investment in new Ann Arbor machines—and, it's going to be so this year.

**Will You Be One to Profit? We'll Tell You How to Increase**

Write at once for this information and learn also about the new Ann Arbor styles and the new Bale's Book Free. Send postal for it today.

Ann Arbor Machine Co., Box 408  
ANN ARBOR, MICH.



### Summer Following

About the time that this work should be done our farmers are usually very busy, and therefore it behooves them to do the work done as quickly as possible. The quickest and best way to do this work is with a Superior Wheel Disc Harrow and Cultivator. This tool is made in four, five, six, seven, eight and nine foot lengths, and they thoroughly turn over the ground the entire length of the machines. The reason for this is that the discs are set at a permanent angle to the line of draft and every disc cuts from its front edge to the rear edge of its neighbor. Therefore they leave no spaces between the discs that are not thoroughly stirred. Then, too, each harrow is provided with a center-cut disc which takes out the center. Each disc and drag bar is independent in action and provided with strong spring pressure and more or less pressure can be had by means of the powerful levers. Depth of cut is also regulated by this means assisted by the ground wheels. Any boy who can manage a team can operate a Superior Wheel Disc Harrow and Cultivator, and do more work in a day with one harrow and one team than two men and two teams can do with plows. Send for a Superior Wheel Disc Harrow booklet to The American Seeding-Machine Co., Incorporated, Springfield, Ohio, read all about it, and then tell your implement dealer to let you see one. If he cannot do it, let the makers know and they will see that you get one. This harrow is fully warranted to do everything claimed for it.

### P. & B. Fence Anchors

Keep hogs from going under your High Fence. Hold them in crossing depressions. Prevent stock from lightning by ground connection. Hold in any soil. By their use you can set your posts 35-40 Ft. Apart. Simple, cheap, easy to use. No tiling necessary. Special driving tool free with orders of 100 or over. Ask your dealer or write to J. M. PEEL & BRO., Box 105, Marysville, Ohio

### CIDER PRESSES

The Original Mt. Gilad Hydraulic Press produces more cider from less apples than any other and is a superior HYDRAULIC PRESS. Holds 10 to 40 barrels daily. Also butter, codgers, vinegar presses, etc.

**CATALOGUE FREE.**

THE HYDRAULIC PRESS MFG. CO., 106 Lincoln Ave., Mt. Gilad, Ohio.  
Or Room 113 D, 39 Corlandt Street, New York, N. Y.



### Monarch Hydraulic Cider Press

Great strength and capacity; all sizes; also gasoline engines, steam engines, saw mills, threshers. Catalog free.

Monarch Machinery Co., 603 Hudson Terminal, New York



### The Money "E" Power of Making

The favorite with hay makers everywhere. The most efficient work with least labor. Powerful, safe, long lived. Various styles and sizes of presses, horse and steam power. Send for catalogue.

Collins Plow Co., 1116 Hampshire St., Quincy, Ill.



# With the Editor

Two towns in which I spend a good deal of time have public markets. One is Springfield, Ohio, where there is a huge market-place, where an enormous business is done three days each week. I believe the farmers there get better prices than they would if the truck and provision business were altogether in the hands of the stores, as it is in most places; and I know that the townspeople are able to live more cheaply than where the retailers' combine holds full sway. By the public market the middleman is very largely robbed of his power to extort. On market-day in Springfield, the town is filled with farmers, and the hands of the housewives with full market-baskets.

On four sides of the market square the sidewalks and the street itself are lined with people trading, and inside the big stone building are literally thousands doing the same thing. It is an animated, a picturesque and a mighty profit-suggesting scene.

The other town I have in mind is Madison, Wisconsin. It has a very pretty and a very clean and a very feeble market. The people do not seem to pay much attention to it as yet. I should think that both the farmers in that vicinity and consumers in the city would afford to go to some trouble in the matter of making the Madison market a great one.

Prices of necessities of life in the town are high—much higher than in Springfield, it seems to me. Why do not the progressive Wisconsin farmers make a concerted effort to place their wares on sale, and advertise the fact in the proper places—the columns of the local papers, in the street-cars and on the bill-boards?



People coming and going

In many places, but the farmers should work locally for its revival. An esteemed Illinois reader, Mr. J. L. Graff, favors us with an interesting account of the monthly "trading day" of the town of Blue Island in the following language:

BLUE ISLAND probably has the oddest farmers' "market-day" organization in Illinois if not in the entire country. The day is regularly set for the first Thursday in each month of the year, rain, shine or snow. This queer custom has been in existence for thirty years, originally it was set on Tuesday, but this interfered with election-day arrangements, so it was changed to two days later, and has been held at that time ever since.

On this market day a horse may sell for \$250 or \$35, even more or less, and other stock brings a similar great range in prices. Some good cows are sold or traded for and subsequently are distributed over a wide area of territory. Some of them have splendid calves at heels.



A scene on the side streets

The function is held on the public street, or, for that matter, several of them, and sometimes full two hundred teams are seen at the sidewalk or tied up at different places on both sides of the street. In each wagon there is something for sale or exchange. It is a common meeting-place for the farmers within a radius of ten miles to meet and sell their farm animals, harness, vehicles and other farm appurtenances. A great quantity of poultry and a big product of eggs of a great variety of farm fowls, mostly for settings, are disposed of.

Along shortly after noon a queer sight is to be seen in Blue Island. The business section is located high up on a bench from the streets on which the selling and exchanging has taken place, and there is a steep hill leading to this business center. Traveling up the hill, on the sidewalks and in the middle of the street, people are seen leading and carrying the greatest and queerest aggregation of live stock imaginable. One man may be leading a cow and calf, a farmer has a horse tied to the back of his buggy, a boy is seen with a goose in his arms, the latter all the time protesting in the full capacity of its nature, another boy has three Leghorn hens in a basket, still another lad is carrying in his arms the cock that belongs to the nucleus of a poultry flock. Other persons are seen carrying harness, bridles, collars and saddles, and many like articles.

While citizens of Blue Island largely are buyers, a deal of trading is done among the farmers themselves. Some of the animals have changed owners at this same market-day meeting several times, until some of them are too old to do further live duty, and have been brought in to be rendered. Some of the creatures have been traded and retraded so often that actually they seem to know what is going on, and confidently expect to be led to another new home.

Now, here is a fine old custom, which makes town life and farm life more interesting, and more profitable. Many Ohio towns have their market days and markets, and wherever they have ever been brought to a prosperous condition, they seem to persist. Doesn't this prove that they are profitable?

I wish I could hear of local movements for them, wherever conditions seem favorable. It seems to me that it is the farmers' move in the matter. The towns can't be expected to provide facilities, when there is no demand for them; but if a score or more of farmers would come every week on a certain day, with their produce, taking pains that the townspeople are notified, the affair would in many cases grow into a public market, which would be a real factor in the prosperity of the farms in the neighborhood, in a better acquaintance among farmers and consumers, and in cheaper living for the dwellers in town. If old markets are prosperous, why not have a thousand new markets?

CLASSIFICATIONS	PAGE
<b>Agents Wanted</b>	
Thomas Manufacturing Company	7
<b>Carriages and Accessories</b>	
Century Manufacturing Company	12
Electric Wheel Company	10
Harvey Spring Company	9
Ohio Carriage Manufacturing Company	10
<b>Correspondence Schools</b>	
National Salesmen's Training Association	7
Page-Davis Company	7
School of Illustration	15
<b>Curry-Combs</b>	
Thomas Manufacturing Company	7
<b>Farm Engines</b>	
Monarch Machinery Company	2
<b>Farm Tools and Implements</b>	
Ann Arbor Machine Company	2
Collins Plow Company	2
Dick Manufacturing Company, Joseph	7
New Process Manufacturing Company	7
<b>Fences and Fencing Materials</b>	
Bond Steel Post Company	7
Peel & Brother, J. M.	2
<b>Fertilizers</b>	
German Kali Works	7
<b>Foodstuffs</b>	
Hires Company, Charles E.	16
National Biscuit Company	10
<b>Hair Goods</b>	
Ayers, Anna	19
Parker's Hair Balsam	19
<b>Hay-Presses</b>	
Ertel Company, George	7
Spencer, J. A.	11
<b>Household Miscellaneous</b>	
Huenefeld Company	15
Hazel Atlas Glass Company	16
Schmoller & Mueller Piano Company	19
White Mountain Freezer Company	15
<b>Hydraulic Presses</b>	
Hydraulic Press Manufacturing Company	2
<b>Land</b>	
Sacramento Valley Development Ass'n.	7
<b>Patents</b>	
Coleman, Watson E.	7
Evans & Company, Victor J.	7
Farnham & Sues	7
<b>Publications</b>	
The Country Gentleman	11
Root, A. I.	10
Woman's Home Companion	8
<b>Roofing</b>	
Barber Asphalt Paving Company	12
Century Manufacturing Company	9
<b>Seeding-Machines</b>	
American Seeding-Machine Company	2
<b>Separators</b>	
American Separator Company	12
De Laval Separator Company	9
Sharples Separator Company	12
Vermont Farm Machine Company	12
<b>Sporting Goods</b>	
Eastman Kodak Company	20
Mead Cycle Company	11
<b>Stock Foods and Remedies</b>	
Mineral Heave Remedy Company	10
Minor Company, W. E.	10
Newton Remedy Company	10
Schofield & Company	10
Shiefflin Manufacturing Company	10
Somers, Harold	16
Young, W. F., P. D. F.	10
<b>Telephone Apparatus</b>	
American Telephone and Telegraph Co.	9

*Robert Lued*

## ABOUT ADVERTISING

FARM AND FIRESIDE does not print advertisements generally known as "readers" in its editorial or news columns.

Mention FARM AND FIRESIDE when you write to our advertisers, and we guarantee you fair and square treatment. Of course we do not undertake to adjust petty differences between subscribers and honest advertisers, but if any advertiser in this paper should defraud a subscriber, we stand ready to make good the loss incurred, provided we are notified within thirty days after the transaction.

FARM AND FIRESIDE is published on the 10th and 25th of each month. Copy for advertisements should be received twenty-five days in advance of publication date. \$2.00 per square line for both editions; \$1.00 per space line for the eastern or western edition singly. Eight words to the line, fourteen lines to the inch. Width of columns 2 1/2 inches, length of columns two hundred lines. 5¢ discount for cash with order. Three lines is smallest space accepted.

# FARM AND FIRESIDE

PUBLISHED BY  
THE CROWELL PUBLISHING COMPANY  
SPRINGFIELD, OHIO  
Branch Offices: 381 Fourth Avenue, New York City; Tribune Building, Chicago, Illinois  
Copyright, 1911, by The Crowell Publishing Company  
Entered at the Post-Office at Springfield, Ohio, as Second-Class Mail Matter

## A BLUE MARK

In the square below indicates that you are an old subscriber and that your subscription expires this month. Renew by accepting one of our offers before they are withdrawn.

## SUBSCRIPTION PRICE

One Year (24 numbers) 50 cents  
Canadian, 1 Year . . . 75 cents

Subscriptions and all editorial letters should be sent to the office at Springfield, Ohio, and letters for the Editor should be marked "Editor."

Money, when sent through the mails, should be carefully wrapped in cloth or strong paper so as not to wear a hole through the envelope.

Vol. XXXIV. No. 19

Springfield, Ohio, July 10, 1911

PUBLISHED  
SEMI-MONTHLY

## Is It Worth While To Stack Grain?

THE Department of Agriculture says that it pays to stack. In Circular No. 68 of the Bureau of Plant Industry, the matter is taken up briefly, but in true departmental style. A great many farmers have been convinced that the improvement in the grade of grain alone is sufficient to pay for the labor of stacking. Many contend that stacking entails no additional expense—in which case, the betterment of the grain would all be clear gain, not to mention the saving of waste. Here are some of the remarks and the conclusions of the bulletin:

The farmer who properly stacks his wheat secures it against further loss from exposure to weather, while the one who allows his grain to stand in the shock from three to six weeks, waiting for the thrasher, runs the risk of having it deteriorate in quality from No. 1 or No. 2 to No. 4 or even "no grade."

Another gain which may result from properly stacking the wheat is that it will come out of the stack dry and thrash out clean from chaff, thus preventing the loss sustained when thrashing bundles that are damp and tough from rain or dew. With the bundles in this damp condition, considerable wheat remains in the heads or is blown over as "whitecaps" and goes to the straw pile. This is usually a total loss, as much of the straw in the Great Plains area is burned.

Improvement in the quality and condition of the wheat is not the only benefit derived from stacking the crop. In addition to making the crop safe should several heavy rains come after harvest, which would prevent thrashing and cause rapid deterioration, the stack-thrashed grain can be placed in tight bins and kept, or it can be shipped direct to market without imminent danger of heating and spoiling in transit. Also, the shocks are removed from the field, so that plowing may be begun at once, and all good farmers readily agree that such early plowing is productive of good results in the next year's crop.

### SUMMARY

(1) The average yearly area of wheat in the United States for the last ten years has been 46,578,000 acres. The average yearly production during the same time has been 659,509,000 bushels.

(2) Of the winter-wheat acreage 44.3 per cent, and of the spring-wheat acreage 94.7 per cent, or a total of 29,876,000 acres, were grown each year in the Great Plains area, where much of the wheat stood in the shock exposed to unfavorable weather for a considerable time while awaiting the thrasher.

(3) The results of this exposure in the shock to the effects of rain and sun are a bleaching in color, an increase in moisture content, and a decrease in test weight per measured bushel. Continued exposure brings about sprouting and molding in the shock.

(4) Increasing the moisture content causes a decrease in the test weight per bushel, which is not entirely regained when the sample again dries out.

(5) Appearance, condition and test weight have a direct and immediate effect on the market grade, and therefore on the market value.

(6) "Sweat" in wheat is probably due to biological action which still takes place when the wheat is assembled in bulk after it is cut. When this "sweating" takes place properly in the stack, improvement in color, condition and test weight results. The milling and baking qualities are also improved by this "sweating" process.

(7) The added cost, if there be any, as a result of stacking may be fully offset by improvement in the quality of the wheat and the higher prices resulting therefrom.

(8) Gains other than those resulting from the improvement of the grain itself are also to be secured by stacking the wheat.

The noon-hour of many a harvest-field has been enlivened by a discussion of the question as to whether or not grain will go through a sweat in the bin if it is dry when put in, in cases where it is thrashed from the shock and has not gone through the sweat.

This bulletin gives the conclusions of science. It will sweat. And when it sweats in the stack, the sweating improves the grain in more ways than one.

Take things as they come, but sift them before you store them.

The farmer who scripps his boys and girls on good books and papers is building the road that will lead away from the farm, and it will some day be traveled at lightning speed by those he loves best.

When you own an automobile, you have to conjure up some other excuse for not going to church on Sunday than the time-worn one of mercy for the team which has been worked so hard through the week that it needs rest.

## Using the Schoolhouse

SCATTERED about over the land are localities where the development of the schoolhouse as a social center has made great headway. In such places, the schoolhouse is used for debates, socials, moving-picture shows, lectures, and generally for the purpose of getting the people of the neighborhood together.

Rochester, New York, is perhaps the best instance of a city where the school social center has become so important as to be the most vital local issue. In some parts of the nation, the use of the schoolhouse as a social center in rural neighborhoods is said to have made



good advancement. Many of our readers must live in such districts. We should like to hear from them in comment on their local experience. If the thing has succeeded, to what extent? If it has failed, why?

The schoolhouse seems to us to be used only about half as much as it might profitably be; and in view of the money invested in it, and the need of meeting-places in the country, the situation is one which seems to invite improvement.

## The Safest Bull

IF you want to be reasonably safe in handling bulls, I will you select the cross one or the kind one? You are probably safest with the bad one—you will be on your guard with him. In all human affairs, the open danger is the one which does the least harm.

Summertime tries out the farmer's wintertime good intentions.

There is no plagiarism in using the best ideas of successful men in running your farm.

## The Penny-Postage Trick

HAVING succeeded in wiping out the postal deficit, Postmaster-General Hitchcock has become an advocate of penny postage. He wants to reduce the rates on letter mail one half. By this means he would again put the service a good many millions in the hole every year. And whether he so intends or not, he would give the opponents of parcels post the chance to say, "Parcels post? Out of the question! How can we run the risk of increasing the deficit by the expense of a parcels post? Penny postage has placed the government in a position which makes it necessary for us to go slow. No parcels post until the deficit is wiped out."

The hardest blow which could be struck at parcels post would be dealt by the adoption of penny postage. There are large concerns whose stamp-bill is big, and which would see a great saving in the opportunity to mail a letter for a cent. But they do not need the saving. And the ordinary citizen does not want it. He is perfectly willing to pay two cents. The present rate is no bar to business.

First-class mail is the great revenue-producer of the Post-Office Department. It should remain such. And most of the demand for penny postage which is springing up is from the opponents of parcels post. Penny postage is a stalking-horse from behind which parcels post is to be shot at and, if possible, killed. Let no one be deceived about this.

## Ohio's Agricultural Education Law

OHIO seems to be making a start in the direction of systematic agricultural education in the common schools. Her new law provides for the division of the state into four agricultural districts with a district supervisor of agricultural education in each, whose duty is to teach the teachers in the institutes, to cooperate with school boards, to lecture and to give general aid and comfort to the cause. These district supervisors are to receive two thousand dollars a year, and expenses up to one thousand dollars a year. The salaries are too small to command the services of specialists—that's the first defect in the law. The act provides that the district supervisors shall be removed from office if they remove from the district, but there is nothing in it—or, at least, in the draft of the bill before us—which makes it necessary that he live in the district before appointment. It is to be hoped that the state commissioner of common schools will construe this so as to allow him to appoint specialists in such education wherever he can get them, whether in Ohio or Iowa or Canada. They are scarce, and his search for them should not be confined to the district. The rocks before the law are politics. Here's hoping that it escapes shipwreck.

Weedy fence-rows and roadsides are often the enemy who goes forth at night and sows your grain-fields with tares.

## Talk is Cheap—But Valuable

THE principal of a school at Kirksville, Missouri, writes us, sending in her subscription, and saying, "The editor of a Missouri farm paper tells me that FARM AND FIRESIDE is one of the finest of farm journals."

Every day we get letters saying such things as these: "FARM AND FIRESIDE is the best farm paper published," "FARM AND FIRESIDE is the one paper we should retain if we could have but one."

Suppose every subscriber should say these same things in conversation or writing, only once in a year, to a farmer friend, what an enormous good it would do FARM AND FIRESIDE! It would give us fifty thousand additional subscribers. It would help us in many ways.

Talk is cheap—but in such a case most valuable. This is a gentle hint to YOU. Will you think about it?



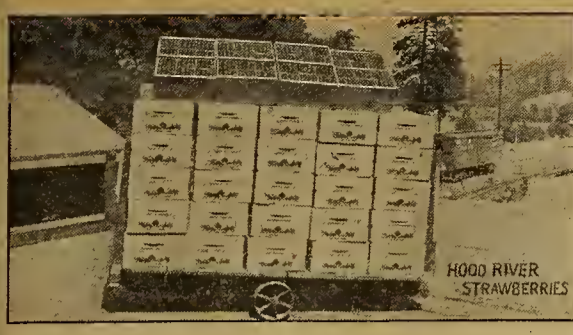

# Our Homeseekers' Excursions



## III.—Experiences in the Oregon Country—By H. Thompson

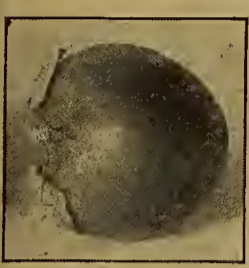

**R**ECENTLY I have noted a move on the part of some Eastern newspapers toward giving their readers some facts concerning this "Oregon Country," which includes, of course, the whole north-western coast, even into Alaska. I say western coast, because few who start West stop short of the coast cities, where they confidently hope to get data that will enable them most quickly to find what they most desire, which means land, health, or remunerative employment.

Regarding this acquisition of land, which is explained by the printed matter scattered broadcast throughout the East, at the expense of the railroads and community organizations, which expect to profit thereby, there remains nothing unsaid from an optimistic viewpoint. But much that might be said in a cautionary way is prominent through absence. Take the state of Oregon as the most favored section of all the Oregon country, and compare it with Kansas as to area. Oregon, with her 96,000 square miles, has but 14,000 square miles more than Kansas, while the population of Oregon is but about one half that of the Prairie State.

### From Fancy Down to Facts

This fact alone leads one to the conclusion that there must, at least, be great opportunities here for the home-builder to get a farm home at small cost, particularly as statistics show millions of acres of vacant public lands unappropriated, and also show more than half our population as living in the cities, which lends force to the arguments used to lure the farmer to try to better his fortunes in the Far West. To the one who expects to live in town, the congested city conditions have no terrors, because he thinks he can't make his conditions worse, and if half the truth is told, he sees hope for betterment. But let us see what are the actual facts.

Our newly arrived emigrant who has pulled up stakes "back yander," paid his debts, and who is once more a free man, with a few hundred dollars in his pocket, stands ready to begin life anew in Oregon. He knows how slow and hard the dollars came to him in the East, and resolves to make them do double duty out here. "But how?" is the question.

He was a close observer of the country seen from the car-windows on his westward journey, and frankly he did not see much to impress him with the agricultural possibilities, nor will he have cause to change his mind upon further investigation without first entirely revising his preconceived notions of farming as he has known it, for this is the semi-arid farming region of America, and the problems and successes are along new and untried paths to our traveler.

### In the Hands of Real-Estate Men

He hardly needs to be told that his small nest-egg would prove but a drop in the bucket of needed and unavoidable expense, so he thanks his stars that he is bound for that fabled garden-spot, the famous Willamette Valley, where he has been told there is no winter of discontent, but all is glorious summer, with wonderful fruits to feed and please the world of sordid dollar-grabbers. And as he passes from the arid and sage green of the upper country, through the frowning Columbia River gorge into the mild climate, the evergreen hills and verdure, with balmy breezes or its mist-laden air, he feels that he has, indeed, found the promised land and that this must be the valley he is seeking, although it is yet the broad river and frowning bluffs, until within an hour's ride of Portland, when broad acres of cultivated fields, cozy homes, big barns and groves of firs form an enchanted land to eyes tired of the monotony of the intermountain trips.

Soon the cheap hotel claims its own, and an awakening begins. Up to this time, romance, imagination and hope have dangled the rainbow hues of the future before him. But now the rosy tints begin to fade. Every other man he meets is a

booster for some real-estate interest seeking to absorb his few precious dollars. He cautiously listens, hoping to gain some chance crumbs of information from those around him. He is used to hearing of perhaps one hundred and two hundred dollars per acre for land, but what is this? Someone says \$1,000, another speaks of \$1,500, and so it goes into the clouds.

### Wall Street's Grip on Western Land

The price of a good little farm in his home country is required here to get an acre. In half a panic he looks up some reliable real-estate man to learn more of his chance to get a nice little farm home. He now is a marked man, provided his few dollars are considered worth while, and the size of his pile measures the number of his new-found friends. He decides

this land, but while red tape lasts there is small hope of favorable results. Then the timber-wolf (or hog) has vast forests for his own, so that one can scarcely find a decent quarter-section for sale, though enough men will be found to locate a tenderfoot on a claim, if he is credulous enough to believe them and their yarns. Or, perhaps, these same men will locate the homeseeker on good, level bunch-grass lands all ready for the plow, provided you will put up from one hundred to two hundred dollars in advance, or sign papers so that they are pretty sure to get it. But remember, they know the land game, and you do not, and they will beat you in the end. You might as well learn now and here that the time to get cheap lands in the Oregon country has gone by, and if you have a home and are

implements, food, clothing, building-material are much higher than in the East, while labor organizations face a constant influx of labor, both foreign and native, who are forced to accept any price offered for their labor and are not permitted to organize for protection and a proper wage, without meeting the united opposition of big business interests which are endeavoring to get you to come West to be plucked by them.

For six months each year labor is in moderate demand, for two months more it is at a standstill or slowly reduced, and for four months the laborer goes begging, often spending any small surplus he may have saved. This may be applied to the whole state, but is especially true of Portland, since this, like other coast cities, is a terminal, hence a dumping-place for those seeking employment. Don't credit the stories told of constant employment at big wages, for they are no more true there than at any other city. These facts you can easily verify. Thousands of homeseekers are stranded here and are so far in debt that they cannot return.

Believe me, when I say that many who are anxious for you to come West, care nothing for your welfare, and only hope to exploit you to their own profit. If you are a good citizen with money to burn, we want you here, so, also, you are wanted where you are. Unless you can afford to make a thorough investigation before locating, or have something definite in sight, Oregon, like most countries—or even more so—is a gamble; don't gamble unless you can afford to lose the money and time. You may possibly win, but the cards are against you.

If you care to know more of the United States public lands, a postal to the commissioner of the United States General Land Office, at Washington, D. C., requesting homestead pamphlets, will get the figures. But the area in Oregon is more or less mountainous, rough and timbered, with nearly one fourth of the state for forest reserve. Of the lands yet in reach, all of which I know are in the high altitudes, subject to summer frost, and hard to make a living on until accessible to railroads—long ago promised, but not yet built.

### The Man Who Makes a Farm By Joel Shomaker

**T**HE man who makes a farm on a homestead claim is a nobleman. He breaks away from the friends and environments of youth and asserts individuality. He enters into partnership with nature, develops a home and establishes a business. The strings of conventionality are severed and the ties of society unbound. With the combination of health, energy and intelligence, he utilizes the forces of soil, water and sunshine in expanding the fields of agricultural independence.

The man who makes a farm in the North is a commander. He fears not the snows of winter, but makes practical use of the sunshine of summer. He emulates the ant in storing, during the harvest season, for the days when icebergs shall close the gateway to commerce. He counts on the morrow and heeds the advice of boyhood, to look out for a rainy day. He rejoices in performing that which others hesitate to undertake—the plucking of prosperity from the fertile vaults of frosted fields.

The man who makes a farm in the West is a builder. He enters a field, formerly occupied by special interests, and publishes a new page in the history of civilization. He wrests the range from the sheep baron and cattle king, and introduces a new era in peopling the earth with families holding the small farm units. His example is followed by thousands of homeseekers, and the region once known as private herding-ground becomes a center of public schools and churches.

The man who makes a farm in the United States is a patriot. He displays his love for his country and its future greatness, in proving that national prosperity depends on individual happiness. Not content in working for others—in eating the bread of a non-producer—he goes forth and brings from the soil that which makes kings of men and queens of women—the ringing coin of wealth.



An Oregon Apple Orchard



Willamette Valley Stumpland

not to spend from \$300 to \$500 per acre for a ten-acre place that he is shown can be made worth \$1,000 per acre in a year or two, but will go farther from the cities and get cheaper land.

Alas, where can it be found? Certainly not in the real-estate man's hands. Nearly every place he sees is for sale by people who were induced to buy, but whose now small horde of fast-dwindling coin makes it necessary for them to save themselves if they can. In order to unload their land on the new-comer, they, too, become boosters, and so the endless chain is built.

Suppose, however, the new-comer does not buy, but seeks farther for the vacant lands, of which he sees great areas, only to learn that one eighth of the entire area of this state is held in vast grants from the government to interested parties for imaginary improvements. These owners all do business in Wall Street, and almost without exception refuse to sell these lands which are choicest in the state. True, our government is trying in its ponderous way to regain title to much of

making a living in the East, or are coming anyways near it, you are a fortunate individual. If you don't believe it, just do as I did, and as thousands of others have done. Try the game with your puny resources pitted against the grafter whose millions run parts of this government and everything in it worth while, and come here to pick up some of the glittering bargains you read about, but don't say no one warned you or tried to show you the real situation. Natural resources are varied and rich, but cannot be fully utilized until the great battle now on between the people and the predatory interests is won by the people. You have the same fight to wage at home that we have here.

### The Scale of Wages

And don't you believe that a dollar is coaxed into your pocket one whit easier in Oregon than it is in the East, whence our recruits come. Wages here, according to my observation, average below those of the East and Middle West, while expenses are more often double. Machinery and

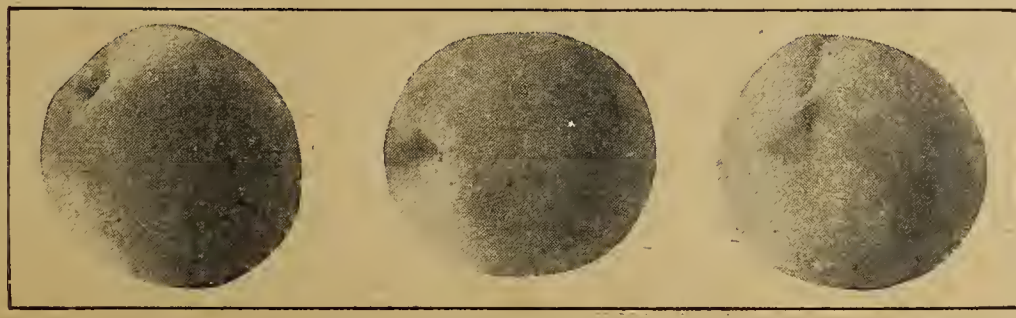





# WHICH HANDS?

\$100 in Prizes to Readers, and  
\$5 Each for Usable Contributions

**L**OOK at the July WOMAN'S HOME COMPANION and see the interesting and amusing prize offer to readers. It is an offer of four cash prizes for the most successful answers to a question asked about five girls' hands. First prize, \$50; second prize, \$25; third prize, \$15; fourth prize, \$10. It is fun to make the answer, and there may be money for you in your answer.

**I**N FARM AND FIRESIDE for June 10 we promised to say more about the WOMAN'S HOME COMPANION. Now the COMPANION is a periodical which every woman in a FARM AND FIRESIDE family would like to have because of the great money-saving and time-saving service which it performs. Its practical departments are of the very greatest use to housekeepers. They contain a perfect mine of definite suggestions, which, as we know, help women to save work and dollars and worry in the preparation of food, in the preparation of clothing both for themselves and for their children, in the arrangement of the household, and in many other ways. We have absolute proof that the daily lives of tens upon thousands of people are affected in a material and definite way by the contents of the COMPANION. Read, for example, the following statement from a Chicago lawyer. Here is a man who says candidly that he himself does not read the COMPANION, but that he feels its influence nevertheless. This man has profited by the continued presence of the COMPANION in his house. Here is his statement:

"I do not read your magazine, but I feel the effects of it more directly than you can possibly imagine. Many of my house arrangements are ordered after your suggestions, and, I am told, some of the best ideas used in the home management of my children came from your pages. Last, but not least, I have good food, some of which is cooked according to your instructions. Oh, I have respect for the WOMAN'S HOME COMPANION, and very definite reasons for my respect."

**B**UT it would be a mistake to emphasize the practical service of the COMPANION so strongly that the reader would fail to grasp an idea of other great and equally important characteristics of this extraordinary woman's publication. In the first place it is physically beautiful—filled with wonderful illustrations made by the ablest artists in the world. In the July number, for example, there is a full page reproduction in colors of a painting by F. Hopkinson Smith which is well worth using as a decoration in the home. It is so inserted in the number that it can be removed and preserved by readers. In the second place it contains a great variety of notable stories and special articles. There is no more downright interesting reading being published than that which is appearing from month to month and year to year in the WOMAN'S HOME COMPANION.

The COMPANION also always has a stir to it that is refreshing and entertaining. The "Which Hands?" contest referred to above is merely one of many such contests that will be in the magazine during the coming year.

15 Cents on all news-stands. \$1.50 a Year.

**THE CROWELL PUBLISHING COMPANY**  
Springfield, Ohio

## Farm Notes

### Hay-Fork Plans

**A** READER in southern Missouri asks for information concerning hay-fork ropes and the best way to arrange them so that the man on the load can communicate with the man driving the hay-fork team. The barn in question is forty-eight feet wide and thirty-two feet long. The hay door is eight feet wide, and the present arrangement of the ropes and hay-carrier is shown in Fig. 1.

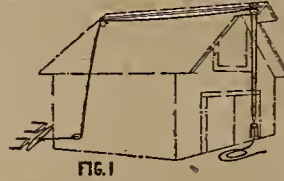

Personally, I like the standard four-strand rope, seven eighths of an inch in diameter. The four-strand rope costs one or two cents a pound more than the three-strand rope, so that the cost is a little more per foot than the small increase per pound would indicate. Usually, however, the four-strand rope is made of better material than the three, and, because it has more weight per foot, it is stronger than the three-strand rope. It is, also, more flexible and more convenient to handle. To insure the greatest life, a rope seven eighths of an inch in diameter should not run over a pulley less than eight inches in diameter. Of course, it will not break at once by being run over a small-diameter pulley, but the tendency to chafe the strands, one upon the other, on the inside, will tend to powder the rope, and so wear it out.

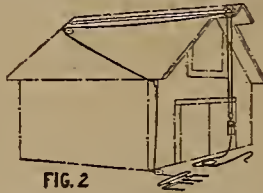

Figs. 2 and 3 show the manner of arranging pulleys so that the hay-fork team is in front of the barn. In Fig. 2 the rope is brought diagonally across beneath the roof and out under the eaves at the end of the barn where the load stands. It then goes down outside the barn to the ground pulley, through which it passes to the eveners.



In Fig. 3, the rope runs as directly as possible under the roof to the pulley, outside the wall and under the eaves. Then the rope runs straight down to the ground pulley and some distance along the ground to the eveners at the end of the barn.

H. W. RILEY.

### What It Rains to Some Folks

IT ISN'T raining rain to me,  
It's raining cats with horns;  
In every ugly drop I see  
Some cockle-burs and thorns.  
The clouds of black bewitch the day  
And overwhelm the town;  
It isn't raining rain to me,  
It's raining needles down.

It isn't raining rain to me,  
But fields of jimson weeds,  
Where every buccaneering bee  
May sting you till it bleeds.  
A curse unto the happy!  
And him who says it's nice!  
It isn't raining rain to me,  
It's raining beggar's lice.

WILLIAM J. BURTSCHER.

### A One-Man Hay-Rack

**H**ERE is a hay-rack that one man can easily handle alone. Fig. 1 is the bed of the rack. AA are the two-by-ten bed-pieces sixteen feet long. BBBB are oak two-by-fours fastened to the bottom of the bed by heavy

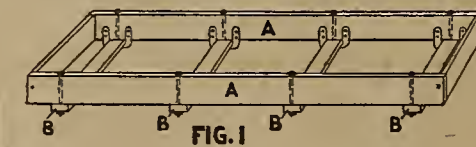

strap-iron that is bolted to the inside of the two-by-ten bed-pieces with two-and-one-half-inch bolts. The two-by-fours are further secured by bolts running through the bed-pieces and through holes near the ends of the two-by-fours. A two-by-ten plank at each end of the bed, held by a rod and nut, makes the bed solid without a nail. Fig. 2 is the back end of the rack. C is one of four two-by-sixes, seven feet in length, to which two sixteen-foot boards, ten inches wide, are bolted or nailed at the outer ends. Then you can floor right across the top or floor the bottom of the bed, as you prefer. I floor my rack right across the top, as it is much more convenient when unloading.

D is one of two angle-bolts that holds the top of the rack firmly to the bed. The other one is at the front end. The bolts are one-half-inch iron rods, eighteen inches in length, with a thread cut at bottom end and a square angle-hook at top end. They hook

over the rear and forward end two-by-sixes and go through the oak two-by-fours just inside of the two-by-ten end-gate of the bed, as shown in Fig. 3.

Put on a washer and use a crank nut (N), to draw down the bolt as tight as you can, and your rack will be as solid as if it were bolted at each corner and in the center. When you wish to take the rack off, loosen the crank nuts, raise the bolts, turn the angle-hooks about so that they release the rear and forward two-by-sixes, and you can

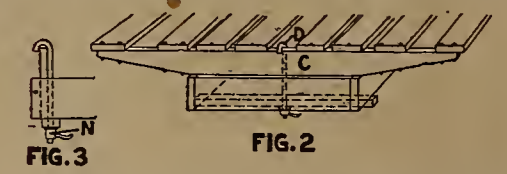

take off the top of the rack, and then you can take off the bed, doing it very easily alone. It takes much less room for storage than the old-style rack. G. A. KIRTLAND.

With all our advanced methods of cultivation, it takes the old hoe and muscle-grease to get the weeds that grow close to the corn. Such weeds sap the hill's vitality. Get after them early.

### What is Your Answer?



**A**RE you encouraging the boys and girls in their school work? Can you tell whether or not they are making proper advancement in their studies? Are they receiving a training at school that not only promotes them in textbook education, but which also develops those manly and womanly traits you so much desire in them? Nine out of every ten farmers would be compelled to answer to the above questions: "I don't know." How, then, are we ever to expect any improvement in our present slack system of rural schooling? M. COVERDELL.

### Don't Neglect the Cow-Pea

**T**HE cow-pea has been pretty generally exploited as a valuable forage crop and as a legume that can secure its supply of nitrogen from the air. Of course, the cow-pea can be used as a means of enriching the soil, but it should be remembered that the crop must depend upon the soil for its mineral food, and if the soil is not already rich in mineral plant-food available for the crop to feed upon, these elements must be supplied. Cow-pea hay shows a larger per cent. of ash than either soy beans, timothy or clover, and all these crops require considerable mineral food. Here are the percentages of ash found in the four forage crops mentioned:

Cow-pea hay	7.5 per cent.
Soy-bean hay	6.2 per cent.
Clover hay	6.2 per cent.
Timothy hay	4.4 per cent.

The above figures not only indicate the mineral food required for the growth of the crop, but they also indicate an important item for consideration as to the food value.

Most of our grain foods are rather deficient in mineral matter to make them economical feeds. Especially is this the case with whole corn, which contains only 1.5 per cent. of mineral matter.

The cow-pea grain shows the following food constituents: Ash, 3.2 per cent.; protein, 18.3 per cent.; carbohydrates, 54.2 per cent.; fats and oils, 1.1 per cent.

As to the cultivation, that recommended for the South will often fail when practised in the North. The practice of sowing cow-peas at the last cultivation of the corn does not suit us in central West Virginia. There is not enough warm weather after we quit cultivating the corn for the cow-peas to reach maturity. We have practised planting cow-peas between the corn hills to some extent and find that the peas do not seem to injure the corn. The cultivation of the corn is also good for the cow-peas. The peas will not only make a good crop, but there will be considerable vine growth on the corn-stalks which will add to their feed value.

If we take the time to gather the peas by hand, we can get plenty of seed and the rest can be gathered either by sheep turned into the standing corn, or by cattle after the corn is harvested. The sheep will not injure the corn. The roots and vines left on the ground help to keep up soil fertility.

An early variety of peas, such as the New Era, sown with millet, will make a rich feed and a heavy crop if sown on a good soil. The New Era pea and German millet, when sown together, will mature just about the same time and are ready for harvest together.

For best results the cow-pea should not be planted too early, as it is a warm-weather plant. The Iron cow-pea is a good viner, holds its forage well and will mature a crop here in central West Virginia, provided it is sown near the first of June. Farther south the planting may be later. The Iron cow-pea and the New Era are the two best varieties for us that we have yet tested. A. J. LEGG.



## Poultry-Raising

### Some Experience with Capons

IF a poultryman has a fair amount of land, so that he can grow a part of his corn, and is so situated that he can cater to private trade, there is a bit of easy money for him in caponizing late-hatched cockerels. By that I mean birds that come off during the natural season, when weather conditions make it easy to raise them. They reach broiler size too late for the good market, and if carried along to make roasters, they mature sexually just about the time of the annual glut of dressed poultry. From then on they grow coarse and staggy, losing enough in quality to offset the gain in weight. But, when castrated, they keep right on growing, actually improve in quality and are ready for market just when there is nothing doing out of doors and plenty of time inside for the dressing. Prices, too, are good, with the tendency steadily upward.

#### A Convenient Table

My own practice has been to sell the cockerels as broilers so long as the market holds up, but with the inevitable midsummer slump I promptly get out the caponizing table. The outfit illustrated is the result of several years' experience, and, after protracted use, no material improvement suggests itself. The table-top tilts to any desired angle, and the elliptical board, to which the chick is fastened with pieces of shoestring and some jam cleats, is pivoted, so that at all times of the day it is possible to get the light exactly where it is wanted. This is a big factor when it is hot in the middle of the day, and it also makes for good work rapidly done. It will amply repay the few hours of labor required to build it.

Novices almost always wait too long before they operate. Neither size nor age is a reliable guide in selecting the birds

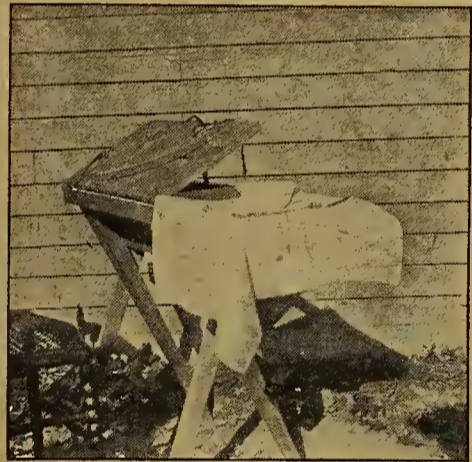

Table With Tilting Top

to be cut, but the color of the comb is very dependable. So long as it shows the yellowish tinge of the little chick, the cockerel may be left to grow undisturbed, but when it begins to turn scarlet, get busy at once. The sexual organs have then begun to develop, and the blood-vessels that have to be severed grow large and tough rapidly.

#### Performing the Operation

There is a knack about starting to caponize a cockerel that makes all the difference between hard and easy work. My own method, which I have never seen in print, is this: After plucking any feathers that may be just where the cut is to be made, I wet the surrounding plumage to keep it out of the way. The veins in the skin are easily seen, and the cut may be planned to avoid them. First, I take up a fold of skin between thumb and fingers, and pinch it thoroughly to expel all the blood. Then, while holding it up from the body, I cut it across and let go. This makes a slit about half an inch long, and with hardly a drop of blood lost. This feature is a great relief to a novice, and makes for speed at all times.

With this opening through the skin, it is easy to see just where to go next. Directions usually say between the last pair of ribs, but I prefer to go in behind the last rib. There is no bleeding at that point, no danger of cutting into the lung, and once through the abdominal wall, one needs only practice to become expert. At first cut the cockerels on each side, but with time one opening will be sufficient. I simply get hold of the testicle with the forceps, twist it about a couple of turns to squeeze the blood out of the cords, and then snip it off with curved shears.

I am a great believer in free range and hopper feeding, and after clipping the flight feathers of one wing to mark the capons while they are young, I turn them loose right from the operating-table. They lose very little time in breaking their thirty-six-hour fast, and are soon running about as if nothing had ever happened. They stay with the pullets until the latter are ready for winter quarters, and from then on cracked corn, green food of some sort, beef-scrap and water will keep them coming beautifully. No especial feeding is necessary, as they

fatten naturally as soon as they are fully plumed. This, of course, is desirable. Barded Plymouth Rocks from a light pullet mating are the best for this work, because it is possible to tell the sex while they are very young. The light under color also makes for the very choicest market carcass. In breeding, however, one must constantly work against early maturity, as this makes the operating difficult, keeps down the size, and is not correlated with the best market type.

Dry picked and nicely trussed, a capon is so attractive in appearance that the price is about the last thing the customer speaks about. The market rises steadily from early in November until the fourth of the following July, but I have always been able to get good prices and the stock out of the way before the hatching season begins. They will bring two dollars on an average when eight months old, and I do not know how to get

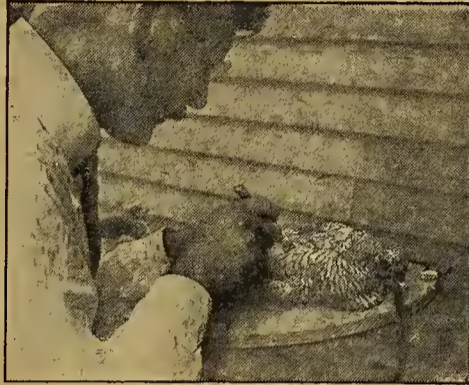

Cutting the Abdominal Wall

that amount out of a pullet in the same time, unless she is something pretty fancy. Considering the small housing expense (capons will stand a lot of crowding on range), they bring the easiest money that comes onto the place.

C. M. GALLUP.

### Cull! Cull! Cull!

HAVE you ever noticed in your poultry-keeping which are the paying hens of your flock and marked the characteristics of these hens? Are you a successful poultry-keeper? Are you climbing upward toward the highest notch of egg-production?

There is room to improve in every business. The joy of a profitable business is in expanding, widening the fields and reaping a greater harvest from them, not for the increase of wealth alone, but for the pleasure the distancing of competitors brings. There is always joy in success.

Profitable hens are industrious. With a hustle and a bustle, they are first out in the morning and first away into fields where necessities for egg manufacture abound.

Mark this type of hen. Keep your eye on her. Compare her with the rest of the flock. How many of the type have you among the many? She is easy to distinguish, see her go under the fence and out. Even the wagging of her tail is familiar and suggestive of business for the hen and for you. This hen knows where she has been before, in the haunts of yesterday where scattered grain and grasshoppers were her diet. She wants the same again to-day; in fact, requires it for the to-morrow's egg.

Her sister, a hen of the same type, is busy scratching under the lilac bush, digging for grubs. I saw the same hen yesterday, deep in the orchard, chasing after some winged insect, which she caught on the fly, and you will eat it in to-morrow's egg.

I hear the lay of this type of hen, as she is busy foraging, come drifting in through my open window. She is not only busy, but



"Mark This Type of Hen"

happy as she works for you and for me, while her sister hens, and some brothers, are lazily congregated "in the shade of an old apple-tree," cocking their eyes at the sunlight that comes drifting through the leaves; or blinking in lassitude at some beetle, or any insect that happens to come near. Some are lying prone, with wings outstretched, upon the warm, inviting sand, which they do not even pick at in fear it might get into their gizzards and lay them up with the laying fever.

How very much like the human is the hen. The busy ones in both human and bird life are those creating a stir in life, while the other, the lazy type, can only squawk and blink at the sun, predicting bad weather with a know-

ing twist of the head, and ruffling feathers that this is such a sorry old world to live in.

Edward Everett Hale says to writers, "Revise! Revise! Revise!" and I say to poultry-keepers, "Cull! Cull! Cull!" which carries with it about the same significance. Get the lazy hen on the march to market, that it may for once bring in a little profit.

Out of a flock of a hundred hens you may sell the half, the unprofitable half, and still gather as many eggs, and realize as great a profit daily as heretofore.

Even as a lazy human hinders the practical usefulness of a household he encumbers, so does the lazy hen hinder the practical usefulness of the laying hen by her very presence, hanging a dead weight about the door-yard.

The poultry business has details, many of which have never been unearthed, which, if brought to light and practised, would revolutionize the business. The detective follows what is but the shadow of a clue, and, with an inborn shrewdness, runs the criminal to earth. The bee follows its perspective instinct through interminable, unexplored space, and finds home and pleasant places.

Let the poultryman follow the hidden clues, the secret tracks, or, better still, his inherited instinct, using his best judgment, and he will drive the business to a successful issue.

J. A. RAISER.

## DE LAVAL CREAM SEPARATORS

not only save their cost every year but may be bought on such liberal terms as to literally pay for themselves. Why should you delay the purchase of the best separator under such circumstances?

THE DE LAVAL SEPARATOR CO.

185-187 BROADWAY NEW YORK 29 E. MADISON ST. CHICAGO

### HARVEY BOLSTER SPRINGS

Soon save their cost. Make every wagon a spring wagon, therefore fruit, vegetables, eggs, etc. bring more money. Ask for special proposition. Harvey Spring Co., 729-17th St., Baelin, Wis.



## The Good Road For Universal Service!

Every man's home faces on a road which connects with every other road and leads to every other home throughout the whole land.

Main highways connect with cross-roads so that a man can go where he chooses easily and comfortably if conditions are favorable. But the going is not always the same; some roads are good—some are bad.

The experts in the South illustrate the difference by showing four mules drawing two bales of cotton slowly over a poor, muddy cross-road, and two mules drawing eight bales of cotton rapidly over a first-class macadam highway.

The Bell Telephone lines are the roads over which the speech of the nation passes.

The highways and by-ways of personal communication are the 12,000,000 miles of wire connecting 6,000,000 telephones in homes on these highways. Steadily the lines are being extended to every man's home.

The public demands that all the roads of talk shall be good roads. It is not enough to have a system that is universal; there must be macadamized highways for talk all the way to every man's home. A single section of bad telephone line is enough to block communication or confine it to the immediate locality.

Good going on the telephone lines is only possible with one policy and one system. Good going everywhere, at all times, is the aim of the Bell system.

### AMERICAN TELEPHONE AND TELEGRAPH COMPANY AND ASSOCIATED COMPANIES

One Policy

One System

Universal Service

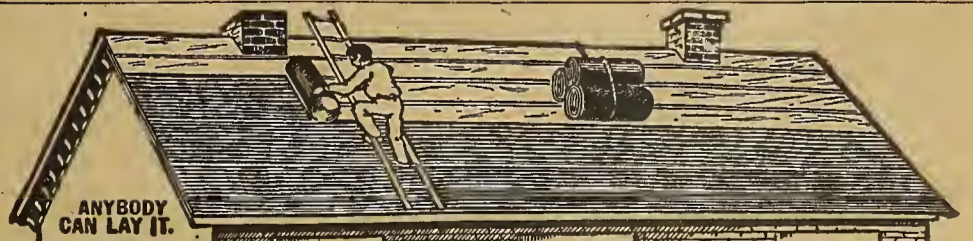

## Rubber Roofing

Warranted For Twenty-Five Years. FREIGHT PAID To Any Station East of Rocky Mountains, except Texas, Okla., Colo., N. D., S. D., Wyo., Mont., N. M., La., Ga., Ala., Miss. and Fla., on all orders of three rolls or more. Special Prices to these States on request.

ONE-PLY - Weighs 35 lbs., 108 Square Feet, \$1.10 per roll.

TWO-PLY - Weighs 45 lbs., 108 Square Feet, \$1.30 per roll.

THREE-PLY - Weighs 55 lbs., 108 Square Feet, \$1.50 per roll.

TERMS CASH: We save you the wholesalers' and retailers' profit. These special prices only hold good for immediate shipment.

Indestructible by Heat, Cold, Sun or Rain.

Write for FREE SAMPLES or order direct from this advertisement. Satisfaction guaranteed or money refunded. We refer you to Southern Illinois National Bank. CENTURY MANUFACTURING COMPANY, Dept. 520, East St. Louis, Ills.



## Live Stock and Dairy

### Silage for Breeding-Ewes

UNTIL this winter we had never had silage to feed our breeding-ewes. We had heard much talk and read much on the subject and found that some men had been feeding it for many years with excellent results. Others had fed it with very disastrous results, so we assumed that good silage, when fed by an observant, careful feeder, would bring good results, and poor, sour or moldy silage fed by a careless feeder would bring disastrous results to the flock. We decided to go cautiously and to have the ewes in the best of condition to start our winter experiment.

We practised the old English method of flushing the ewes about two weeks before mating-time in the fall. That is, we turned the ewes into new fields where the feed was succulent and abundant. We used rape-fields, although clover would have done as well. The ewes were gaining rapidly in flesh and were very thrifty when mating-time came. We planned for the lambs to come between November 15th and April 15th.

#### Good Feeding Plans

The ewes had had an abundance of pasture all fall from the rape sown in the grain-fields. We sowed rape in the corn-fields at the last cultivation, and when we cut the corn for the silo, we turned the sheep in there and let them have the ears that the binder had knocked off. Then, as soon as we could, after the silo was filled, we husked out a small field of corn and turned the ewes into that field and let them have the rape there. Adjoining this field was a field of soy beans. The beans had been cut, thrashed, and the straw-stack was still in the field, and the sheep ran at will around this stack and over the field, and cleaned it up pretty thoroughly. Later in the fall, we turned them into another field where there was rape in the corn-stalks and the husking was not yet finished, so they had considerable corn and really got quite fat, but never too fat; they were robust and thrifty. When the first of December came, they were in the very pink of condition and had had nothing except what they picked up in the fields.

During the first few days of December hard freezes came and froze down the last of the rape and iced over the creek; then we began feeding silage. Very gently at first, and we were always careful to get good, sweet silage. We fed only forty pounds a day to a hundred ewes to start with, and they did not seem to care for even that much, so we began putting on about ten pounds of bran and ten pounds of oat-fannings (we cleaned some of our grain early so as to have the fannings to feed the ewes during the winter). In this way we gradually got the ewes to liking their silage. For their feed, other than silage and light grain feed, they ran to the stalk and stubble fields. By the middle of January they were getting one hundred and sixty pounds of silage and twenty pounds of fannings to the one hundred ewes. We substituted fannings for the bran in the ration about two weeks after we started feeding the silage. In January the ewes began to really relish their silage for the first time, and by February they were quite fond of it, so we increased the feed to two hundred pounds to the one hundred ewes, but did not increase the grain any, and still we allowed the ewes to run in the corn-stalks to pick the rest of their living. The winter was very open with but little cold weather, and the ewes preferred to stay outdoors rather than in their shed, although they were at liberty to run in and out of their shed at will.

#### At Lambing Time

The last week in February we started feeding clover-hay, which we had been saving all winter to feed just before lambing-time. Every afternoon, about an hour before sundown, the ewes would come in from the stalk-fields and we would turn them into the corral where the silage and grain were in their troughs for them. While they were eating their silage, we would fill their hay-racks with a light feed of clover-hay and throw open the gates and let them come in where the hay-racks were. They were in good condition when we started feeding clover-hay, and this seemed to give them an added appetite, and we again carefully increased their silage ration, so that we were feeding three hundred pounds to the hundred ewes, and the ewes began to pick up in flesh. About ten days or two weeks before lambing-time the udders began to fill, and two or three days before the first lambs began to come, the udders of half the flock looked large and full, yet perfectly normal and healthy. When the lambs started coming, they came singles, doubles and even triplets, and all were very large, strong and robust. Many of the ewes which had singles we had to milk out for days till the lamb could take all the milk. We had almost no trouble about the ewes disowning their lambs, the only cases being where the twin would get lost from the mother before it was

very old. To avoid these accidents as much as possible, we built a row of four-by-four-foot pens along one side of the sheep-house to pen the ewes in with their twins. When the twins got to be two or three days old, we turned them and their mother out in the small corral with other twins and had a separate house for them to run into. We were very careful at this time not to over-feed the ewes and to see that they had plenty of clear drinking-water.

#### Lambs Make Gains

By the time the lambs were a week old they were beginning to eat silage and grain with their mothers. Then we built a good-sized crate for them, put in their own little feed-troughs and private hay-racks and went to feeding them in earnest. They are getting what silage they will clean each day, and it is considerable, and all the grain they want is a mixture of one-half oats and one-fourth bran and one-fourth cracked corn. I have taken many brands of these native ewes through the winters and cared for them at lambing-time, but never before have I had such uniform, healthy, large lambs; never such heavy fleeces on the ewes, and never such a robust flock in the spring, and such a high per cent. of lambs as I now have. The lambs are gaining more rapidly than any I have ever fed, and I have one hundred and twenty-five per cent. lamb crop, which, considering the ewes I started with, is excellent. The ewes were purchased directly off the range northeast of Pierre, Sully County, South Dakota. They are predominating Merino type, with a trace of Down blood in most of them. There was a small per cent. of pretty well-shaped ewes in the bunch. The lambs were sired by registered Hampshire Down rams. We will market these lambs as soon as they get to be seventy or eighty pounds in weight and are fat, and will then give the FARM AND FIRESIDE readers the final outcome of the silage experiment of our ewe and lamb feeding at Laverta Meadows. PAUL H. BROWN.

#### When To Drive a Colt

A FRIEND of FARM AND FIRESIDE has a yearling mare colt of Kentucky breeding which he says is well grown, strong and as round as an apple. The colt has been handled a good deal, broken to harness and driven around the farm to a light buggy. He asks if such an animal can be driven back and forth over a three-mile stretch of good road morning and evening.

It is a mighty good thing to get a colt broken to harness early, and a good plan to use her enough to get her hardy. But a yearling colt, after all, is nothing but a baby, and should not be put to any regular work. The distance named, three miles and back, twice a day, makes twelve miles a day, and this, if done every day, is rather too much for a yearling.

I have never depended on my own colts for much regular driving till they were three years old, though, of course, a two-year-old can do more than a yearling. The amount a two-year-old can do depends much upon his size and strength. As I have said, a certain amount of driving hardens up a colt's muscles. But it must be remembered that she has still her growing to do, and must never be expected to grow up and do the work of a full-grown horse, too.

DAVID BUFFUM.

#### Hog-Cholera Serum

THE farmer is liable to regard the serum question as a matter of experimental interest only, or he may have ideas of his own about the manner in which it should be distributed, or about the cost. These things are likely to induce the farmer to decide to let serum alone until somebody else makes the start, or till serum business is put on a "practical basis." This is a mistaken idea for the farmer, and one that may cost him a crop of pigs or hogs. Serum has been applied to herds in this neighborhood in all degrees of infection, always with the same result—namely, the saving of all the hogs not yet sick. Our fall pigs were treated last September when hogs were dying on the farm, and these pigs were fattened out in the very lot in which the hogs all took sick in August. Cholera comes on suddenly at times and works great havoc before relief can be acquired, so that the feeder who anticipates danger from hog cholera should apply to his state authorities at once for full particulars about the serum treatment, so as to be ready to curb the attack without delay and consequent loss of hogs. GEO. P. WILLIAMS.

No up-to-date farmer will be without a hand separator, and the skim-milk, when improved in quality by the addition of some concentrated food, is solving the problem of raising good dairy stock on the farm, in addition to turning every ounce of fat in the milk into butter.

The winter dairyman is the coming man, but he cannot afford to milk in a cold, dirty stable or barn. Let's have better cow-barns.

The cow that loses flesh in October or November will be an expensive one to winter.

# The COUNTRY GENTLEMAN

The Oldest Agricultural Journal in the World  
5 Cents the Copy; \$1.50 the Year by Subscription

THE COUNTRY GENTLEMAN, a consolidation of The Genesee Farmer, 1831-1839, and The Cultivator, 1834-1865, has recently been acquired by The Curtis Publishing Company. After July first it will be published under the imprint that has made THE SATURDAY EVENING POST the familiar friend of every household in the country.

Under its new management THE COUNTRY GENTLEMAN will gradually be broadened in scope and interest. It will deal with the old and the new problems of the farmer and his household, especially those that concern the science of growing crops and the business of selling them.

The Editors will be glad to consider articles and suggestions dealing with the following subjects:

**Field Husbandry:** Mid-summer tillage and harvest methods, silage making, corn harvest, catch crops, fall plowing.

**The Orchard:** Good practice in fruit raising, harvesting apples, peaches and small fruits; cover crops, fertilizing, late spraying methods.

**The Home Acre:** Farming and gardening on a small area, vegetable culture for the home gardener, poultry keeping for eggs and meat, good poultry practice for the farmer and the suburbanite.

**Livestock Breeding and Feeding:** Care and rations for fat stock and management of breeding animals.

**Milk Production:** Feeding for milk, cow testing, soiling to supplement short pasture, solutions of the fly problem, sanitary stabling, and the care of milk.

**Personal Experiences:** Concise, helpful accounts of actual experiences in farming and gardening, in letters not to exceed five hundred words.

**The Handy Man:** Brief descriptions of make-shifts and simple devices that have been found helpful; short cuts in farm operations; minor improvements that can be made cheaply; the care and repair of farm implements; more efficient methods of handling farm machinery—any suggestions that mean a saving in time, money and labor.

**Country Life Improvement:** Short articles dealing with successful rural schools, churches, granges, agricultural fairs, good-roads movements, and farmers' clubs for business and pleasure.

**Photographs:** Good photographs of farm operations should accompany articles whenever possible. All manuscripts will receive careful and prompt consideration and will be paid for, if acceptable, at current rates. Address communications to *The Editors of The Country Gentleman*, 425 Arch Street, Philadelphia, Pa.

THE CURTIS PUBLISHING COMPANY, PHILADELPHIA

It is to your advantage to mention Farm and Fireside in writing to advertisers. Farm and Fireside folks get the very best attention.



**10 DAYS FREE TRIAL**  
We ship on approval without a cent deposit, freight prepaid. DON'T PAY A CENT if you are not satisfied after using the bicycle 10 days. **DO NOT BUY** a bicycle or a pair of tires from any one at any price until you receive our latest art catalogs illustrating every kind of bicycle, and have learned our unheard of prices and marvelous new offers. **ONE CENT** is all it will cost you to write a postal and every thing will be sent you free postpaid by return mail. You will get much valuable information. Do not wait, write it now. **TIRES, Coaster-Brake rear wheels, lamps, sundries at half usual prices.**  
Meade Cycle Co. Dept. F-83 Chicago

**Fastest Hay Press**  
**2 1/2 Tons Per Hour**  
Greater capacity is guaranteed in all Spencer Presses. The guarantee with our Alligator Press says "22 tons in 10 hours or no pay." Large feed capacity—smooth and compact bales, uniform in size. Load full weight into cars. All Spencer Presses are biggest money makers because they give greatest capacity at smallest operating and repair cost. Write today for Free illustrated catalog L. L. describing full line.  
By Guaranteed Capacity  
**J. A. SPENCER**  
115 William St., Dwight, Ill.



**NO SUCH THING  
As Saving Money Through  
Buying a Cheap Machine  
Instead of the Matchless**

**SHARPLES  
Tubular Cream Separator**

The cheap machine will more than lose the price of a Tubular the first year. Many thousand users of cheap separators are discarding them for Tubulars. The cheap machines lasted one year on the average—required ten to thirty dollars repairs—and lost more in cream than the original cost.

**Do you call that cheap?**

Tubulars have twice the skimming force, skim faster and twice as clean as others. Dairy Tubulars contain no disks or other contraptions. Wear a lifetime. Guaranteed forever by America's oldest and world's biggest separator concern. The biggest economy you can make is to buy The World's Best.

On request, a Tubular will be delivered and set up in your home, for free trial, without freight or any other expense to you. Why send any money for some cheap machine?

Separator quality is more important than first cost. Other separators taken in part payment for Tubulars.

Write for a catalogue No. 112 and free trial.



**THE SHARPLES SEPARATOR CO.**  
WEST CHESTER, PA.  
Chicago, Ill., San Francisco, Cal., Portland, Ore.  
Toronto, Can., Winnipeg, Can.

**ONLY \$10. CASH** Catalogue Free.  
Balance \$5 a month, buys this three-year GUARANTEED Buggy.  
Write today for our **FREE CATALOGUE** of Buggies, Surreys, Spring and Farm Wagons.  
Century Mfg. Co., Dept. 519 East St. Louis, Ill.

**\$15.95 AND UP-WARD**  
**AMERICAN SEPARATOR**  
SENT ON TRIAL, FULLY GUARANTEED. A new, well made, easy running separator for \$15.95. Skims hot or cold milk; heavy or light cream. Different from this picture which illustrates our large capacity machines. The bowl is a sanitary marvel, easily cleaned. Whether dairy is large or small, obtain our handsome free catalog. Address **AMERICAN SEPARATOR CO.** Box 1058, BAINBRIDGE, N. Y.

Get the roofing that lasts, for every building on the farm—

**Genasco**

the Trinidad-Lake-Asphalt Roofing

And get the Kant-leak Kleet—the approved roof-fastening. Write for descriptive Genasco book and samples.

**The Barber Asphalt Paving Company**  
Largest producers of asphalt, and largest manufacturers of ready roofing in the world.  
Philadelphia  
New York San Francisco Chicago

**Live Stock and Dairy**

**A Holstein Club Organized**

FOR some two years past there has been a feeling among the farmers of Minnehaha County, in southeastern South Dakota, that some kind of a club should be organized for an occasional social good time and possibly for meetings of profit along other lines. There was a strong organization owning and operating the farmers' elevator, and another owning and operating the creamery, but these organizations were purely business propositions, and the social side was lacking.

We are a busy community, yet not so busy but what we can have some enjoyable social times if we plan for them. Interest in Holstein cattle has been running high here, and after talking over the prospects of organizing a club, some of the leading members of the community thought that we had better have a Holstein cattle club for the purpose of developing a social as well as a business side. So a date was set for organization, and a small self-appointed committee mailed announcements to the possible members of the club that a meeting would be held at the home of Paul H. Brown about eleven o'clock. As it was a social affair, entire families were expected to come, and each wife was requested to bring a certain portion

cattle, and shall sell their milk and cream at the place or places advised by the board of directors. It is the duty of the board of directors to hunt up the markets where the highest quality is wanted, to obtain the highest possible price for the products. Members shall cooperate in selling the surplus young cattle, so that outside buyers may come here with assurances of obtaining cattle in car-loads in a short time.

Every three months a social gathering is held, at which every farmer and every member of every family is expected. The hostess of the day is chairman of the refreshment committee, and each wife is expected to bring or send what the chairman requests. In this way there is a social good feeling all around.

Now as for results, the chairman of the board of directors sent a delegate to investigate the milk and cream market of this part of the state. In a week's time we learned that a high grade of sweet cream could command almost double the ordinary creamery prices, and a contract was signed. Without the certain knowledge that the united forces of the members of the club could supply forty or fifty gallons of twenty per cent. sweet cream daily if called upon to do so, this very desirable contract could not have been secured.

It became evident early in the game that there were not enough cows among the club-members, so a meeting was called and a young man, a judge of dairy cattle, in whom we all had confidence, was sent to Wisconsin to buy more cows and heifers. Each mem-



Lloyd K. Brown Hugh Irvine S. B. Leao Clive F. Brown Ruben Scott  
Carl W. Schliemann Homer Billings I. C. Kingsbery Paul H. Brown E. L. Gould  
The Holstein Club

of the "Dutch treat" dinner to be served. The day chosen for the meeting proved to be stormy, but that did not prevent our sturdy, ambitious people from coming. About an hour before dinner they began to drive into the yard. We are not all rich by any means; some came in top buggies, others in open rigs, and still others in lumber wagons, but no matter, all were friends and all were welcome.

Nearly every rig represented a jolly, happy family, and after they drove into the yard, it did not take long to get the little folks into the house and the horses into the barn out of the storm. With every rig came something good for the dinner. By noon the table was loaded with good things for the inner man.

At the business meeting, held after dinner, officers were elected and a committee was appointed to draw up a constitution and by-laws and set an early date for the next business meeting, which was to be for the men only. It was held in the "Bank of Hartford," as our banker was one of the charter members of the club. After considerable discussing and debating, we drew up a satisfactory constitution and set of laws.

A few of the main points in our constitution are that all members shall own Holstein

ber who wanted more cows told him about how much money he wished to put in and told him to buy with that sum to the best of his judgment.

This young man has returned with the load of cattle, and each man thinks he secured full value for the money he invested. The young man determined, as he bought the cattle, to whom each animal should go. Those buying the cattle agreed to stand the expense of the tuberculin test proportionately, and, in case of loss by failure to pass test, to buy to fill the loss. This was fair to one and all alike, and no one would be a heavy loser. Only one heifer in the load failed to pass, and another heifer of equal value was bought and put in her place.

When all are fair and all members know and trust one another, this kind of business can be carried on to the benefit of all. It calls for a higher standard of living and higher business methods, and it brings greater returns financially, intellectually and socially.

I hope there are other communities in which FARM AND FIRESIDE is a regular visitor where similar organizations can be formed.  
PAUL H. BROWN.

**Cribbing and Its Treatment**

I AM asked if there is any cure or successful means of treating a cribbing, or wind-sucking, horse.

Cribbing, or wind-sucking, is a habit, and when it has become well established, there is no known cure for it. The best that can be done is to prevent the habit. Colts, in teething, frequently suffer pain by the crowding of the center nippers, and they will bite the manger or anything they can press their teeth against to furnish temporary relief. Later, they get the habit of swallowing air, which produces gaseous dyspepsia. The habit can sometimes be headed off by sawing between the teeth with a fine saw so as to relieve the pain caused by the teeth. Then put the animal in a stall without a manger or any other projection for it to press its teeth against. But this will do good only when done at the start of the habit. As all young animals are more or less like young humans, striving to imitate their elders, no colt should ever be kept in company with a cribbing horse. While there are many anti-cribbing bits and various devices in use to prevent cribbing, none are superior to a broad strap buckled snugly around the neck at a point where the throat-latch is placed on a bridle.  
C. D. SMEAD.

Look deeply into the soil before buying. Rocks and sand-hills may yield an existence, but fertile loams make happy homes.

**Building Up the Dairy Herd**

THE increasing demand for dairy cows, despite the amount of substitutes for dairy products sold in the way of oleo and butterine, makes the raising of good cows a profitable business, and one that many more farmers could engage in to their advantage if it were done intelligently.

In the great milk-producing sections of the country the increasing demand for milk, and the prices paid for veal calves, influences the dairyman to dispatch the calf as soon as dropped, or, at most, to keep it only until it is about four weeks old, when it is sold to the butcher. Too often this is all they are fit for, as they are produced without any purpose other than to have the cows freshen.

At the prices which good cows are bringing, fifty to one hundred dollars—registered cows double and treble these amounts—I doubt if there is any branch of the dairy business more profitable than the raising of cows for market and selling them after freshening the second time.

**Where the Profit Lies**

To start in this business, we must first weed out the small producers from our herds, keeping only those whose annual product will net a profit. Then, being guided by the kind of cows in demand in that locality, whether desired for milk or for butter or cheese, procure the best sire of that breed money can buy, and begin a system of building up a dairy herd of grade cows. Select the sire upon the producing record of his maternal ancestors. By purchasing a pure-bred heifer or two at the same time, a start in a small way can be made in animals for registry. One thing should be kept in mind: if the cows retained after the weeding-out process are grades of any particular breed, a sire of that breed should be used. If, for example, you find the cows you have have a considerable amount of Jersey blood, buy a Jersey bull. It would be unwise to procure a Holstein bull. Crossing breeds with the idea of combining the good qualities of both always results in disappointment.

People are willing to pay nowadays according to the producing capacity of the cow; and that capacity must be about double that of the average cow at the present time, if a profit above the total cost of keep is to be obtained.

**The Way To Feed**

The calf must be fed from the start in such a way that the dairy-cow qualities will be developed. Wrong feeding may produce beefy qualities in the best-bred dairy calf. It should have the first milk of the mother, and her milk only for a few days, at least. Whole milk should be fed for the first two or three weeks, gradually substituting skim-milk after that. Don't feed too much. Overfeeding causes indigestion and diarrhea. "A pint of milk to ten pounds of calf" is a variable rule. Watch the calf. It will soon begin to nibble a little hay, but let it be very little at first. A little whole oats—just a pinch—may be put in its bucket after drinking when about six weeks old. Increase the oats gradually, adding a little wheat-bran or oil-meal later. Still later add a few grains of whole corn. By following out this system, feeding regularly, you will have a good cow, provided she has the inherited qualities; if she has not, no manner of feed or feeding will make one of her. After she is six months old, not before, she may be turned to pasture. Keep her growing by feeding well all the time. You can't afford to winter her at the straw-stack.

If she is of the smaller breeds, have her freshen the first time when about thirty months old. If of the larger breeds, eighteen to twenty-four months. Keep her in good condition. It is a fallacy to think a cow must be in poor condition before coming in. Feed the same as a cow in milk, only less amounts.  
R. P. KESTER.

**Ring the Bull Calves**

EVERY bull calf reaches a stage at one year of age after which he will be unsafe to handle with a halter. From that time on, a ring and snap if he is of a beef breed, and a staff if of a dairy breed, will be the only means by which he can be handled safely.

To ring the bull is quite a simple process. The first thing to do is to fasten the youngster securely. If there is a set of bull stocks with a stanchion, this will be the best place for him. If there is nothing of the kind at hand, any means of fastening him securely will do. He may be fastened in a cow stanchion, or tied in a corner of the barn, or to the fence, or anywhere that will be secure.

To make the hole through the heavy tissue between the nostrils requires some sort of a rounded instrument with a sharp point. In our own work we use a trocar that we keep for tapping animals in case of bloot. A pitchfork tine broken off from the fork does very well. In fact, anything of that style can be used. It is not safe to use a knife, on account of the danger of making too large a cut if the bull shakes his head. As soon as the opening has been made, the ring is slipped in and its screw fastened. Then, if some disinfecting material is used, the job will be satisfactorily completed in a very short time.  
H. E. MCCARTNEY.

**THICK CREAM  
Means Sweet Cream**

The density of the cream from the United States Cream Separator is easily regulated by aid of the patented cream screw.

Many users produce cream testing over 60 per cent butter fat.

Thick cream is a great advantage in hot weather because the milk which sours first is so nearly eliminated. Creameries pay top prices for such quality.

**United States Separator**

cream is in great demand at all creameries. Thick cream means less bulk to transport, but more skim milk for feeding. United States Separators hold world's record for closest skimming. They are the Standard Separators of the World.

For your own sake don't buy a "cheap" separator or decide on any make until you have seen and tested the United States Separator. Get the large, illustrated U. S. catalog No. 69.

**Vermont Farm Machine Co.,**  
Bellows Falls, Vermont.



# The FARMERS' LOBBY.

**T**O PHILOSOPHIZE is a dangerous thing. You are apt to be a bore, and sure to be personal. Nobody's philosophy is more than skin deep. It's altogether likely to be a display of his own grouch, and that may not be pleasant to others.

Well, anyhow, it hailed on our farm the other day, and the best I can do is philosophize. You folks all philosophize, or try to, when hunks of ice rattle down, to the accompaniment of thunder and lightning and the big wind, and thrash your wheat out on the ground.

I am a farmer, and not a farmer. I live on a farm a few miles out of Washington, but go to the city every day to toil for a living. The most difficult part of it is having Western friends poke fun at me for trying to raise anything on an Eastern farm, and having Eastern friends insist that it's a bluff. Both crowds are wrong. Farming is a good business East as well as West; and a man who lives on a farm because he loves it, even if he hasn't time to do his own plowing, is not necessarily a menace to society.

The farmer is in bad with the rest of his fellow citizens. He has been making a very decent living, most of the time, of late years; and the rest of the community thinks somehow he is blameworthy for doing it. He sells his pork for eight cents and gets cussed for "demanding" so much. The retailer gets thirty-two cents for ham, and is regarded as a substantial, conservative citizen. It's all wrong.

## The Farmer Not Always Wrong

**E**VER since I was nineteen years old, I have been farming. I have been cleaned out of the profits of two years' hard work in ten days by hog cholera. I have been drowned out and baked out. I guess I know the game pretty well. And all the folks in town have for me, and for farmers in general, is an ambition to pluck us for Rubes when we seem to have something to take, and a desire to foreclose our mortgages when things go wrong with us.

Some friends of mine play the stock exchange at times. It's the only game I know with more chances in it than playing the grain market with real grain, or the stock market with live stock. The farmer gambles all the time; but he gambles with the results of long, hard days of real work. He deserves better than to be derided for a country cousin when he is in hard luck, or skinned by the law-makers and the law-breakers alike, when there is a suspicion that he has some liquid assets on his person.

Right now there is a distinct prejudice against the farmer all over the country. He is considered somehow responsible for the high cost of living, as if he didn't get that in the cervical region the same as townfolk. The farmer needs to be better understood. His business needs to be known about more intimately. This old dope about his soft snap, because his crops grow while he sleeps, doesn't get past with me in seasons when the farmer doesn't get a chance to sleep and the crops are not allowed to grow.

Makes me laugh, though, to hear Western farmers roar about their troubles. They don't know how to parse that noun. It's singular for them; always plural for us down East.

## Where Markets Differ

**I**LIVE in Maryland. Our state is a sort of principality for the Baltimore and Ohio Railroad, with the Pennsylvania getting a slice on the side. Railroad rates are so adjusted that we are practically compelled to use the Baltimore market; and the Baltimore market, having the railroads working for it, is rigged by the people who control it, so that the wheat-raiser gets just as little as they dare offer.

We are one thousand miles nearer the seacoast than Chicago, and wheat ought to bring something like Chicago prices plus freight. But it does well if it's a couple of cents above Chicago. New York is liable to be paying eight to fifteen cents more for our grain—and for Kansas grain—than we can possibly get in the only market open to us.

Take another aspect of it. I want two car-loads of feeding cattle this fall. When I lived out West, getting them was easy. There were plenty of markets in which to buy them—Chicago, St. Paul, Sioux City, Omaha, St. Joe, Kansas City, and all the rest. Real markets, too, in which prices had a pretty certain relation to values. And, besides, the people were interested in them. Well, those markets are open to me, now; they're all

## Rate Problems Need Real Senators

By Judson C. Welliver

I have. I can go to Chicago, and buy feeding cattle. But when I asked my railroad agent about feeding-in-transit rates on them, he made me repeat the phrase, and then said he never did understand about that astronomy business. He thought I was talking about the transit of Venus, bless him!

After some effort, I was assured that there weren't any feeding-in-transit rates in this part of the country. I could ship my stock from Chicago, fatten it, and then ship it on to Baltimore, Philadelphia or New York at the local rate. I figured it out, talked with people who had tried it—and decided not to gamble that way.

It's more exciting to gamble on the hail-storms; you have a chance to be hit by a big one and get a new sensation.

The West has the markets, the rates, the service. It has been fighting for many years to get them, and has won. There isn't any more egregious blunder that a Westerner can make than to imagine that the East gets the benefits of cheap rates, good markets, and all that sort of thing.

Truth to tell, the West has these things because it went after them. It was in the throes of the granger movement when I was born, and now it's insurgent, which is the same thing. It's out to get its bit, and somehow is getting part of it.

That's more than the Eastern farmer is getting. He is overshadowed by the bigger interests of the great industrial centers, and is forgotten. You read about rebates to the Sugar Trust and the steel-makers; but you don't read about feeding-in-transit for the farmer in this region. The Western farmer has gone out and attended to these things for himself. The Eastern farmer has not.

Some day they are going to wake up, down East here, to the fact that the big business of feeding the country is not getting a fair break. Then farming will get a better chance. Right in Maryland there is a political campaign on, in which these issues, in their political aspects, are getting attention. People are awakening to understand what it's all about.

But it's wonderful how little some of these thoroughly practical problems are understood—rate regulation and the like in the East, compared to the grasp which the Middle West has of them.

When the East catches up, insurgency will cross the Alleghenies.

\* \* \*

## The Senate in Action

**A**FTER forty years and more of struggle, the Senate has for the first time passed the resolution looking to amendment of the constitution so as to let the people elect their senators. The resolution received considerably more than the necessary two-thirds majority. It had already passed the House.

The Senate, however, amended it by providing that the federal government reserve to itself power to regulate the method of holding elections of senators. It already has the right to regulate the election of congressmen.

The Southern people fear that this provision may at some future time be taken advantage of by Congress, to undo their various "grandfather provisions" for depriving the negro of his ballot. There is danger that some of the Southern states will oppose ratification of the measure because of this proviso.

This ought not to be permitted, and, as there is only the remotest possibility of any need for federal control ever arising, the House ought to refuse to accept this Senate amendment. The popular election of senators is wanted by the people, and ought to carry. But it is no sure thing.

The truth is, that amending our constitution is about as hard as getting a forty-acre field of wheat to stand up again after it has been pounded into the ground by the hail. Everybody seems to be for the income tax amendment. Ask one hundred men, and you will come back certain that ninety-five per cent. of them favor income tax. Yet seventy-five per cent. of the states have not ratified the amendment, and it is a very close question whether they will. The machinery is cumbersome, the opposing interests are powerfully placed and can get in their work, while the people fail to make their

voice heard all the time. This is unfortunate, but true. The Southern States have small reason to fear any interference with their election laws. They ought to ratify, even if this proviso is left in the amendment. But it is very possible that some of them will not. There will be a few rotten borough states to oppose it, and probably a few of the extremely conservative ones in the East. The outcome at best will be close. No chances ought to be taken of defeating the whole proposition for the sake of a tilt at a windmill.

The vote to adopt the resolution itself was 64 ayes to 24 nays. It is worth while to file away the list of those who voted against the measure. Some time you may have a chance to vote against one of them. It will be mighty good business if you do so. The twenty-four negative votes were cast by sixteen Republicans and eight Democrats, as follows:

Republicans—Brandegge of Connecticut, Burnham and Gallinger of New Hampshire, Crane and Lodge of Massachusetts, Dillingham and Page of Vermont, Lippitt and Wetmore of Rhode Island, Oliver and Penrose of Pennsylvania, Lorimer of Illinois, Richardson of Delaware, Root of New York, Smoot of Utah, Heyburn of Idaho.

Democrats—Bacon of Georgia, Bankhead and Johnston of Alabama, Fletcher of Florida, Foster of Louisiana, Percy and Williams of Mississippi, Terrell of Georgia.

## Interesting Personal Geography

**A**WORD about the geography of that Republican list is a temptation not to be resisted. New England supplied nine of the negative votes; it has eleven Republican senators. One New Englander, McLean of Connecticut, was counted with the affirmative. One, Frye, of Maine, was absent because ill. He would have voted against the amendment if present.

New England, then, mustered ten opposing senators. With them lined up Lorimer, of whom the less said, the better; pieces smell better when they have as little Lorimer in them as possible. Also, there was Smoot, apostle of the Mormon Church. Next comes Pennsylvania, the worst machine-ridden state in the Union. It voted both its senators against popular elections. Couldn't you have guessed that five years ago just as well as now? Then there is Richardson of Delaware, senator from the state made famous by Addicks and gas and perennial corruption.

And, finally, there is Root of New York. That makes up the list of Republicans voting in the negative. They voted as they did because they were opposed to popular election of senators.

As to most of them, I cannot blame them. There are not three men in the sixteen who would have a ghost of a chance ever to return if popular elections should be established in their states.

As to the eight Democrats who voted against direct elections, they all explained that they did it because of the federal-control amendment which I have explained. Maybe that is true, but their sincerity as friends of popular elections would have been better attested if they had looked pleasant and voted for popular elections anyhow.

## A Victory for the People

**A**DPTION of the resolution is a great victory for the people. It marks no millennium, but it does prove that the people can force the hand of Congress when they get busy and keep everlastingly at it. It proves that the people can, by being alert to political situations, manage affairs, even though bosses and rings would like to control.

Don't imagine that all of the sixty-four men who voted for direct elections really wanted it. Something more than half of them do; the rest voted for the amendment because they knew it would be bad for their political health to vote otherwise.

The government is on its way back to the control of the people, and this victory for popular elections is a long step. It will be about three years before the measure can possibly be ratified by the legislatures of three fourths of the states.

Most of the legislatures do not meet again till 1913. Not enough ratifications will be received then, in all probability, and the 1914 crop of legislatures will have to be awaited for the last pull. It will take thirty-five states to ratify, if Arizona and New Mexico are not admitted; if they are admitted, thirty-six will be the number required. Let us hope for it.

# A Case of Starvation

By Pearl Franklin

Illustrated by Charles S. Corson

IF I had the sun in one hand and a waterin'-pot in the other, I couldn't make better weather myself," declared Aunt Sally, admiringly, as she threw a handful of microscopic weeds over the fence. "Just look at that sweet alyssum. Did you ever see the like? And that heliotrope. I'll carry that to Miss Lavinia this afternoon."

"It won't do you no good, Aunt Sally. You won't get in. I just come from takin' butter and eggs there, and I asked could I see Miss Lavinia, and one o' them high-falutin' nurses that brung her back last night told me no one was to be allowed to see her. That laundress they've had while they was getting the house ready was out at the back hedge hangin' up clothes, an' I stopped to have a few words with her. She says there's two nurses—one night and one day—and three doctors, an that there ain't no hope at all. They just brung her home to die."

Miss Henry leaned over the fence hopefully to see what effect her news would have. She remembered, as did the other townspeople, that Aunt Sally had been the family nurse in the big house for years, and that she was suspected of knowing the reason why Lavinia, a capricious heiress of twenty, then an orphan, had left some fifteen years before, to go and live abroad with a distant cousin. But if she knew, her lips had been sealed.

Now again there was hope that she might be tempted to tell what she knew. The night before, as unexpectedly as she had left, Miss Lavinia had returned, carried on pillows, guarded closely by a set of smart foreign servants, whose formidable barrier to the sick-room had proved unyielding to Miss Henry's curiosity.

"Why, where you goin', Aunt Sally?" Miss Henry, who was prepared for an interesting disclosure, was dismayed to see her neighbor turn toward her cottage. "Oh, I'm goin' to get busy," Aunt Sally answered laconically and with an abstracted air, as she disappeared within the kitchen.

Miss Henry lingered a few moments, then, as nothing happened, went on to another neighbor who would be more inclined to talk things over.

Aunt Sally proceeded in a strange way "to get busy." From the old-fashioned chest of drawers she brought forth a clean, white apron which she tied over her blue print dress, keeping well within the shadow of the room so that Miss Henry, peering in, could not see her, but so that she, looking out, could see when Miss Henry went away. When she did, Aunt Sally breathed a sigh of relief.

She took her sunbonnet down from the nail by the door and caught up her market-basket, which she slipped over her arm as she hurried down the path to the small town.

The basket was only a pretense, for she passed by the various stores on the main street as one in a trance, looking neither to right nor left. At the drug-store she paused long enough to look up at the open windows overhead where hung a certain printed shingle, weathered and beaten. Taking a deep breath, she began climbing the stairs which led at the side of the building to the floor above. When she arrived at the top, she took off her sunbonnet and fanned herself. Her lips were trembling and her blue eyes, peering through spectacles, seemed to be storing up determination. She stood looking at a man who sat at a desk in the first office, his elbows on either side of a big book at which he stared fixedly, without reading.

This was John Temple, the attorney whose sign swung from the window. As he turned around and looked at her in a dazed sort of way, he showed himself to be a large man, tall and well built, but carelessly groomed.

"Why, Aunt Sally," he said in a strange voice that he seemed to have brought from a long way off, as he pushed up his glasses and blinked his eyes, "this isn't the day to clean the office, is it?"

"No, it ain't," Aunt Sally agreed.

"Nor the day to get your money?"

"No, it ain't," repeated Aunt Sally, "but it's the day for some people I know to wake up and stop bein' foolish."

Mr. John Temple merely stared at Aunt Sally. He himself was not acting naturally. He appeared hurt; looked out of the window; seemed to be getting ready to speak, but did not speak.

"You know she come home last night?" Aunt Sally half whispered. The man nodded miserably.

"Then what you a-settin' here for?" she cried. He was silent for a time, then answered almost harshly: "I went last night and I went this morning. She wouldn't see me."

"How do you know she got word you was there? Like as not them smart-actin' people of her'n didn't let her know."

A light struggled in the man's tired eyes. "I suppose I shouldn't have gone, but when I heard that she was so sick—Aunt Sally—I never knew what she meant to me until I heard that. I hadn't realized how I was



"She had risen up in bed. Her large eyes burned angrily. 'Stop!' she cried; 'I forbid you to mention his name.'"

dragging along here any old way, waitin'—just waitin'—for her to come—or to call me back."

"You had no business waitin'," Aunt Sally scolded, the better to hide her emotion, "you both have been to blame."

Then she was silenced by what she saw. He did not say anything or make a sound, but his eyes and the movement of his shoulders, as he buried his face in his hands on the desk, seemed to take the words out of her mouth. She made several motions, one toward him, one toward a chair. But what she really did was to take up her basket from the floor and go toward the door.

"It's noon now," she said in a resolute voice, as she paused there, "if you'll come up this evenin', say after that six train goes back to the city, Lavinia'll be waitin' for you."

"Will you come?" she asked, as he did not speak. After a while he nodded his head. Great men become children at times, like that, in the presence of a real mothering heart.

It was a stiff-necked Aunt Sally who went back up the main street. Her snowy hair was tucked in tightly beneath her gray sunbonnet; the trembling lips were pressed closely together; the blue eyes behind their spectacles shone aggressively, and there was a flush on the round, good-natured face.

Arrived at her cottage, she stripped the heliotrope plants of all their heavy blooms and placed them thoughtfully in her basket. Then she went to a far corner of the yard and broke off some mint.

"Her mother always liked this," she muttered to herself, "and that mutton broth I made her this morning, like I used to make it for her ma, I'll just take that, too. No, I ain't going to stop to eat any lunch," she said as she turned away from her neat little kitchen, as though it had asked her a question.

On her way to the big house she met Miss Henry, who had just left the third neighbor's and was going home. Miss Henry stopped.

"I'm a-goin' to stand here and see if you get in, Aunt Sally. I know you won't," she called cheerfully, as Aunt Sally stalked on.

"Well, ye needn't look for me to be put out, Miss Henry. When my mind's made up for me, the way's usually made up, too, and it'll take all kingdom come t' hold me back."

A surly gardener was working on the gravel paths. He looked the stranger over scornfully and did not move his wheelbarrow out of her way. Sunbonnet, apron and market-basket spelled servant to him. Aunt Sally sniffed and stalked on to the kitchen.

The Swiss couple who presided there were very busy. Aunt Sally threw up her hands in horror.

"You're not cookin' that mess for a sick woman," she cried.

They sought to wither her with their looks. "My husband make dishes like you never heard of," scolded the woman, "he is one fine cook. It is not only a sick lady we have to please. This bouillibasse is the favorite dish of le docteur."

"Oh, that's the way the land lays," remarked Aunt Sally, looking about the old, familiar kitchen where she had sat and chatted while "Miss Lily" directed her two servants and, in doing it, accomplished as much work as either one of them.

She left the couple staring after her and, disregarding the forbidding air of the place, went into the dining-room.

The large, mahogany table was set with fine napery and silver for five.

"Got comp'ny?" she inquired, with sinister politeness, of a trim maid who, going from place to place, added fragile wine-glasses.

"The doctor has a consultation in the library. Two other doctors. And the two nurses are in there, too," replied the maid, surprised out of her customary pertness by the sudden apparition.

"And where is your housekeeper?" asked Aunt Sally,

pausing on her way into the hall, a cunning light in her eye.

"She is up with Miss Tate," explained the maid, still dazed by the authority of Aunt Sally's manner.

"And ain't there another girl?" she asked from the door.

"There is another maid, she is not in."

The butler, on his way from the library, a tray filled with decanters and glasses in his hand, stopped, transfixed, and stared after her as she passed him in the hall and went on to the front stairs.

"It's just like the Red Sea partin' for the Children of Israel," she panted fervently, as she beheld the portly figure of the housekeeper retreating down the corridor on the second floor.

Then she hurried across the hall into a front room and locked the door behind her.

"I reckon I'd better lock 'em out o' that other door, too," she muttered, looking through to a darkened chamber where she knew the object of her anxiety

was to be found. This had been "Miss Lily's" dressing-room, too, and that, beyond, her bedroom.

There was no sign of life from the bed as Aunt Sally passed by it to lock the farther door, but some moments later the sick woman stirred uneasily, feeling the presence, conscious of the steady, searching gaze upon her.

The wistful brown eyes stared, incredulous, for a full moment, then two thin, weak arms were up from the coverlid, and Aunt Sally had the wasted figure in her motherly embrace.

"There, honey, don't ye cry. Don't ye cry, honey. Your old Aunt Sally's here and goin' to take care of ye. Don't ye cry, little girlie."

"But I'm not crying, Aunt Sally. I—I can't cry any more, I guess. I'm—too—tired—"

Then Aunt Sally discovered that it was she who was crying, and when she looked at the face of the woman on the bed, she knew why.

It was not the resemblance to "Miss Lily," though there was that, as she had looked that last time, that very last time, but—

"When Lavinia's sick, she all goes to eyes," Aunt Sally had often told the child's mother, years before.

And now Miss Lavinia had all gone to eyes—and to a pair of eyes that near wrung Aunt Sally's heart out of her motherly old bosom.

She stroked the thick braids of dark hair, the thin, white face, the hands and wrists—it was as though the skin were drawn tightly over the bones. But these were not so sad as the eyes—those dark, hungry eyes.

"Aunt Sally, why haven't you come before?" asked Lavinia, looking eagerly at the dear, kind face.

"Darlin', I had t' sneak my way in. They wouldn't let me see you," sobbed Aunt Sally, who had not yet become reconciled to the look in those eyes.

"Oh," Lavinia whispered supinely, "I suppose I wasn't able."

"I guess you are able to see your Aunt Sally. It's strangers you ain't able to see," the old nurse cried, holding the listless form jealously to her aching heart. "I guess if no one knows what's the matter with you, they'd better get out and let you alone."

"They do know," whispered Lavinia slowly. "Starvation." She smiled wistfully into the honestly amazed face of Aunt Sally. "I—I can't eat anything. I don't know why, but I don't want it—that's all. I just want to die—"

"Now, listen to that," Aunt Sally scolded, trying to steady her voice, "want to die! Ain't you ashamed! Ain't you—here," she said, suddenly, reaching down into the basket by the bedside and incidentally wiping her eyes on her apron hem. She brought up the heliotrope and the spray of mint. "Here—that's what you need, a little bit of God's outdoors to make you 'shamed of yourself to want to die when everything's encouragin' folks t' live."

The thin hands grasped the flowers convulsively. The fine nostrils drank in their perfume as a sufferer drinks in ether.

"I knowed it," Aunt Sally sniffed, more to herself than to the sick woman, "you air hungry, but you don't know what you're hungry for. It ain't eatin'—them fool doctors and nusses is goin' at your stomach, when it's your heart needs medicine."

"Flowers are bad in a sick-room," said Lavinia dully, as one repeating a lesson that is learned, her eyes still devouring Aunt Sally's face, her nostrils buried in the fragrance.

Aunt Sally roused herself. "I s'pose sunshine and air is bad, too, from the looks of this room. But I'm goin' to have my say now. I took care of your mother, and I took care of you when you was a baby—and you don't seem to be much more'n a baby again. Honey, I'm a-goin' to get rid of every human bein' on this place. They're suffocatin' ye. If you're goin' to die like they say and you say yourself, I'm a-goin' to see that you die nice—with plenty of sun and air and flowers. If you can't live with a smilin' face, I say, die with one."

[CONCLUDED ON PAGE 17]

# SUNDAY READING

## Honesty in Little Things

By N. B. Mace

ONE afternoon a lady had just seated herself in a street-car, when a young lady, a stranger to her, also entered, sat down beside her and tossed an extra transfer into her lap, saying in a low tone as she did so, "Here, take this and use it." "No, thank you," came the reply, "I would just as soon pay my fare." "No, use this," the girl rejoined, "he will not know the difference." It was not agreeable to have this little deception thrust upon her, but this lady revolved quickly in mind whether to let it pass and accept the transfer as a trifling and harmless courtesy from a stranger or to ring true to her own inward monitor and pay her fare at the risk of giving offense.

As the conductor approached a moment later, she threw the questionable transfer on the floor and paid the fare. To the look of surprise on the face of the girl, she answered, gently, "You see, I thought I should know even if he didn't." Ah, there was the point!

To the lady, the matter of five cents was not much one way or the other; to the tramway company, the missing of a fare now and then could not make any appreciable difference; and to the girl, youthful and sweet-faced, it appeared to be merely the good joke of "getting ahead" of the street-car corporation—the offspring of a false, but quite generally approved, sense of shrewdness among many of her seniors.

This incident, trivial, indeed, in itself, aroused the question, "Where does honesty begin?" How momentous must the matter be to require one to ring true? Can honesty really be estimated according to the greater or lesser monetary values involved in the outward act?

Is it not rather a question of deciding inwardly on the side of right; of just being true to the good old golden rule?

If "nothing is either good or bad, but thinking makes it so," can there be any matter too trivial to warrant the effort of casting thought about it on the right side?

"Thou desirest truth in the inward parts; and in the hidden part thou shalt make me to know wisdom."

An attained life of absolute honesty must of necessity be made up of innumerable little honesties.

It was not so much the amount of the money withheld by Ananias and Sapphira (Acts 5) that wrought their downfall—for the entire amount was, as Peter told them, theirs to give or to keep as they chose—but their own inward thinking that they might withhold secretly, while outwardly appearing to measure up to the righteous demands upon them, this inward dishonesty it was, detected by Peter, which ruined them. They had sullied their sense of truth and lost immeasurably more than they had essayed to withhold.

Is it not easy to suspect that they had failed to ring true in various little things prior to this momentous decision?

Suppose one fails the mark of unalloyed truthfulness in some little matter to-day, another to-morrow, each lapse making another easier; is he not, by means of these same little things, placing in the foundation of his building—whether business, domestic, social or what not—the false stones which later may produce the toppling of his Babel tower, years of work thus resulting in failure, where success might have been his meed, had every tiny stone been fairly cut and squarely laid?

No wise builder overlooks the demand for honest measurements in every little thing.

No intelligent husbandman can ever be made to believe that he can juggle with his seeds when planting for the autumn's harvest, knowing full well nature's obedience to the inviolable law, "whatsoever a man soweth, that shall he also reap," and he is glad for the dependableness of nature.

Everyone appreciates a man or woman who has given proof of reliability, of honesty in all ways, and we can—every one of us—increase the number of reliable ones in the world by watching that no "little foxes" of little dishonesties are allowed to "spoil the vines" (Sol. Songs, 2:15).

We shall find, too, that when we ourselves are most scrupulous in little honesties, we shall also be most kind in this silent rebuke of little dishonesties in others; and we shall find much happiness in these right decisions in little things, for this is the beautiful way truth has of permitting us to reap *more* than we have sown.

## The Seeded Asparagus

By Rev. Eliot White

YES, I see the broad acres of the farm under the midsummer sun, filled with beauties of leaf and fruit of many sorts, and these all I know are worthy of praise and record. But this morning I am drawn to linger here by the plot of seeded asparagus, till I have appreciated better than hitherto the charm of form and color that it offers to passing eyes, so generously, yet so often with scanty response of admiration.

The delicacy of the feathery green plumes, as the warm breeze lifts and sways them, I realize now is beyond the power of words to express, yet how many times I have gone by their plot with scarcely more than a preoccupied glance! These slender, tree-like forms might be a grove of dwarf willows, with pliant trunks and limbs all as green as their lacy foliage, beneath which some Lilliputian folk could wander and call the space their noble park.

And like tiny Japanese lanterns strung on the dainty branches, see how the round scarlet seed-capsules glow through the thicket above and below! Exquisite ornament, indeed, they supply in the midst of the fairy green, and the delighted eyes feasting on their gay brilliance quickly find other resemblances with which to compare them: rubies glinting through folds of frail lace on a costly dress, ruddy-checked apples pleading to be gathered from their high, leafy coverts in an orchard, or flame-bright holly-berries adorning a shrub whose spiky leaves had been transmuted to fringes soft as a bird's plumage—something of all of these the gleaming asparagus pods suggest in the flooding August sunshine.

When one of the capsules is pinched between the thumb and finger, it ejects from its pulp a closely packed cluster of black seeds, some soft like shriveled currant-skins, others hard like glistening pellets of coal. How the awed wonder at the miracles of birth and development in both the vegetable and animal worlds sweeps over one afresh who pauses for a little to consider the mystery of such germs of life!

The imagination, so stimulated, readily runs forward from this midsummer scene to another springtime, and sees the swift, prolific sprouting of the new stalks, or "turions," of the erect drumstick shape. How can the marvel ever come to seem commonplace, that out of these black pellets can rise, as if in the building of a fairies' temple, the slender columns of the prized vegetable, marked with the wedge-points of their enfolding scales?

And ah, what birth of color out of unpromising origins! No description can do justice to the adornment of the growths unfolded from just such somber jet beads as roll here on the palm of my hand.

It is scarcely strange, then, that one finds such an experience as this with the seeded asparagus become a kind of parable for a thousand other revelations of mystery and charm, where before one had been all but blind. Places one has visited without deeply observing them; nature's manifestations that one dares to call "familiar," when in truth they are almost as strange as when they were first seen; human faces that one thought were intimately known, yet that one day suddenly shine with such new light as to leave one appalled with the unfathomed wealth of existence always underlying the surface that it usually presents to view—in all these occurs again that miracle of fuller vision which was long ago fitly called a "falling of scales from the eyes."

Yes, to-day, because I stopped to admire and brood a little over the humble grace of the seeded vegetable, it has rewarded me with fresh joy in the richness and generosity of the universal life, and quickened my response to that inexhaustible beauty of the world that does not shrink from visiting the inward sense through gateways lowly and ever near at hand.

## By Reflected Light

By A. P. Reed, M. D.

IN A pitch-dark corner of my cellar, my lantern discovered for me a lone potato that had sprouted and formed some leaves.

A peculiar thing for utter darkness was revealed on closer inspection—namely, these leaves were quite *green*!

Since chlorophyll, the green coloring matter of plants, requires sunlight for its production, I reasoned that *someway*, sometime, King Sol must smile on this

little potato, and the potato must be making the most of the smiles.

So I concluded to watch and visit this potato at other times.

It didn't need many times, however, since the next morning, on peeping down, I discovered Old Sol beaming on a bright tinplate directly opposite the potato, and then I noticed that the potato was borrowing this light for its own use. Being a regular recipient for an hour or two of this reflected light, it had absorbed chlorophyll sufficient to green its shoots.

This poor little potato, struggling against great odds, with no soil and very little sun, was doing itself more credit than some things out in the broad daylight!

The lesson to us is that we should be very careful what sort of lights we are, and be very ready to catch and use the *good* reflections of other lights—those reflections or influences that go to make us better, bigger and happier beings.

"Act well your part, there all the honor lies."

## The Strength of Christ

By Orin Edson Crooker

DARIUS COBB, the celebrated Boston artist, was one day showing some of his paintings to a visitor in his studio on Tremont Street. Among others, he brought out his "Christ Before Pilate," a small canvas that has attracted world-wide attention. At the same time, he uncovered a large picture, not then entirely finished, the subject of which was "Christ Stilling the Tempest." The same idea of Christ appears in both of these paintings—namely, One who possessed strength of will and purpose; One who was magnetic, courageous, fearless.

The visitor said to his artist friend, "Mr. Cobb, it seems to me that your conception of Jesus is different from that of other artists, but I cannot tell just wherein this difference lies."

"I'll tell you," said Mr. Cobb, turning quickly to a table and picking up a well-thumbed magazine. "Here is an illustrated article, entitled 'Ten Great Artists' Christs.' Look at these illustrations carefully and point out, if you can, a single figure of Christ which does not have an effeminate appearance. Artists," he went on, "have tried so hard to remember that Jesus was gentle, that they have forgotten that He was physically strong. They have thought of Him so often as blessing the little children that they have forgotten that He also threw the money-changers from the temple and upturned the tables of those who made the sacred place a den of thieves. In these pictures before you," he said, turning to his own work, "you see Christ as One who was both physically and morally strong; He is set forth as One who was thoroughly courageous, flinching neither at the sight of the waves which threatened to engulf His boat, nor before the eye of Pilate in whose keeping at the moment lay His very life."

Here is a thought for the present day. The need of the hour is for men of courage, men in whom physical and moral strength combine to make them fearless in the cause of righteousness. Out of such a combination of physical and moral courage comes the strength of Christ. He who possesses it conquers in His name, even as St. Paul, who said, "I can do all things through Christ which strengtheneth me."

## Life Can Be Rebuilt

By Charles Henry Prather

SOMETIMES you hear it asked, "Can I get a beautiful future out of a ruined past?" This is often the question the sinner asks when he is ready to abandon his sins and seek a new life. And it is a fair question to ask.

Some time ago a minister was appointed to preach in a Rescue Home. In passing through the hall in company with the lady manager, he stopped to admire a beautiful vase covered with vines. After he had enjoyed it for some moments, the lady said to him: "Doctor, that vase is made of broken pieces of glass." In a moment his sermon was changed. He thought of the many broken lives in the home, and prayed that he might be able to make one over that it might relive. He told them of the broken vase, and how they could rebuild life and get a beautiful future out of a ruined past. Three came up at the service and gave themselves to God and His work, and proved to be faithful servants until the end.



Look for the Diamond Trademark on the Wrapper

ONE of the joys of childhood is lost to the youngster who has never tasted that first spoonful from the wonder-working ice cream freezer. Isn't an ice-cream freezer a debt that is owed to the children? Especially now that the

## Triple Motion White Mountain Ice Cream Freezer

does the work as if by magic. Fussing and musing are done away with, and instead—the richest, smoothest ice cream in quick time.

Write to-day for our recipe book "Frozen Dainties." Tells how to make and serve scores of delicious desserts.

The White Mountain Freezer Co. Dept. Y, Nashua, N. H.



It is to your advantage to mention Farm and Fireside in writing to advertisers. Farm and Fireside folks get the very best attention.

BE AN ILLUSTRATOR—Learn to draw. We will teach you by mail how to draw for magazines and newspapers. School of Illustration, 26 Page Bldg., Chicago, Ill. Send for catalog.

## USE A PORTABLE BOSS OVEN

With Patented GLASS DOOR on your stove or range, either oil, gasoline, acetylene, alcohol or gas.

No more spoiled bakings or worry—No more wasted heat—No more jarring or chilling of oven. Housewives can see their baking without opening door. Economy and convenience both guaranteed in the BOSS—a polished blued steel oven lined with tin and asbestos.

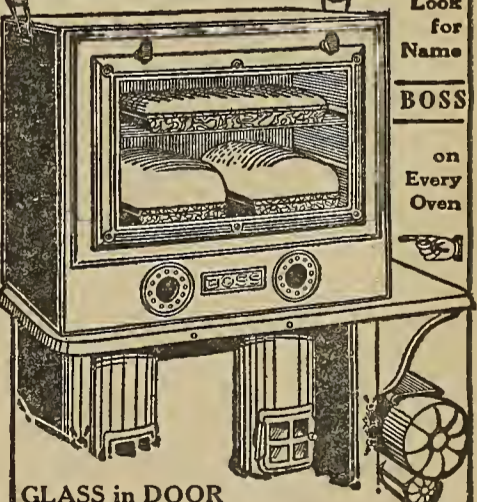

Look for BOSS on Every Oven

GLASS in DOOR is guaranteed not to break from heat because it is secured by our patented yielding pressure retaining strips, which permit expansion and contraction. Glass door fits snugly in one-piece beaded front, and is held tightly in place with two turnbuckles, preventing escape of heat.

Baking qualities and ventilation superior to any other oven or range. All heat goes right into the open bottom, and is perfectly distributed to all parts of the oven by means of our patented Heat Deflector. Flame always visible through small mica windows. With the BOSS a baking costs less than a cent. It will many times over pay for itself in saved bakings to say nothing of saved fuel.

Ask YOUR Dealer to show you the BOSS Glass Door Oven. INSIST upon seeing the name "BOSS" stamped in the front of Oven. Then you know that it is genuine and guaranteed.

FREE: Our valuable Recipe Book, containing many cookery helps and full description of BOSS Ovens sent FREE on receipt of postal, plainly written, giving your own and your dealer's names and addresses.

THE HUENEFELD CO., 2732 Spring Grove Ave., Cincinnati, O.

## This Jar Solves Your Canning Problem Forever

### Madam, Your Fruit Canning Trials are over at Last

When you sweat over a hot stove—carefully, carefully stirring that fruit or vegetable you want your folks to enjoy next winter—you really ought to put it into jars that you can absolutely depend on.

Here is the jar you CAN depend on.

### Atlas E-Z Seal



Air CAN'T get into this jar for the top clamps down like a vise at a slight finger touch.

It opens just as easily.

Takes fruit and vegetables whole thru its large, smooth mouth. Never cut fruit again. That robs it of much flavor. Store it whole in the E-Z Seal Jar.

This jar is made of better glass than most jars. Glass that is hard to crack. Think of this before you spend another cent on buying jars.

All the good qualities of all fruit jars are in this jar. It hasn't got a single fault. Insist upon getting it.

Remember the name "Atlas E-Z Seal."

HAZEL ATLAS GLASS CO.  
Wheeling, W. Va.

### DAISY FLY KILLER



placed anywhere, attracts and kills all flies. Neat, clean, ornamental, convenient, cheap. Lasts all season. Made of metal, cannot spill or tip over, will not soil or injure anything. Guaranteed effective. Of all dealers or sent prepaid for 20 cents. HAROLD SOMERS, 150 DeKalb Ave., Brooklyn, N. Y.

### MAKE IT AT HOME

One package of

### Hires HOUSEHOLD EXTRACT

makes 5 gallons of old-fashioned, home-made Rootbeer, the most wholesome and gratifying of all drinks, the finest of temperance beverages. It is Nature's tonic drink, made from roots, bark, berries and flowers. Sold everywhere, or mailed on receipt of 25c.

THE CHARLES E. HIRE COMPANY  
213 N. Broad St.  
Phila., Pa.



# The Home Interests' Club

By Margaret E. Sangster



THE busiest time of the year for the woman who lives in the country falls in midsummer and is, therefore, upon her now. When I speak of the country, I mean anywhere beyond the long rows of houses close together, the narrow streets and the towering buildings that more and more belong to our cities. The woman who lives on the farm and the woman whose home is in a suburb share equally the privilege of wide skies, pure air and green grass and trees. The eye that cannot endure the glare of the streets is rested as soon as it can look into depths of foliage. As for the children of the city, how we wish that we could pick them up and carry them, one and all, into the country in July. The Fresh-Air Homes springing up everywhere are boons to the children of the tenements, and the children of the avenue mansions and the brown-stone fronts, the children of wealth who never go outside their doors unattended, they, too, are happy when in July they go to the farm where Uncle Henry lets them ride on the hay, and grandfather always has a seat for them in the surrey, when he starts on his round of errands in the morning. Grandfather knows that little Tom and Bessie are in the seventh heaven when allowed to drive, and the cob, on his part, knowing every inch of the road, trots along as safely when dimpled hands hold the reins as at any other time.

The farmer's wife is not always able to drop her cares and enjoy an afternoon in company at this season, because the farmer must make hay while the sun shines. The demands of the soil and of the work in the fields take precedence of everything else. If there are hired men to be fed, their three meals a day require a great deal of the personal attention of the farmer's wife. To obtain help is nearly impossible, unless she consents to import it from the next large city. This she may do, if she is willing to install in her kitchen a mother and child, or a mother grown old, who has a young relative, unskilled and new to the country, but ready to be taught cooking and housekeeping.

#### The Problem of Help

When the club met, the Fourth with its pleasant celebration was over, the debris of torpedoes and firecrackers had been swept away and the hostess of the afternoon was delighted to find a larger number present than she had expected. "We just had to come," explained little Mrs. Fay, "and as my sister is at home from college and spending her vacation with me, I left her to prepare supper and show what she knew about practical cooking after her courses in domestic science. I think it probable that each of us has made a special effort to get here to-day, that we may compare notes about entertaining guests in summer."

Mrs. Artrogge, who was presiding for the day, asked the club to waive preliminaries and be entirely informal. This plan, by the way, was favored by the members, who were bent on getting as much out of the afternoon as they possibly could, and were, therefore, contented to dispense with unnecessary routine. It transpired that everyone present had a house filled with company, and that no one was provided with entirely satisfactory domestic help, except Mrs. Halloway, whose Rebecca had come to her from an orphanage at the age of fifteen, and had ever since been regarded as one of the family. Rebecca was a staff on which to lean, and Mrs. Halloway said with emphasis that until matrons made up their minds to do as she had done, and in their early married life receive a young girl into the home and give her the best training, the subject of domestic help would always be a stumbling-block in the path of health and happiness.

"Every young girl might not turn out as Rebecca has," objected a clever woman who was a new-comer in the community. "I, for example," she proceeded, "have little skill in management and would greatly prefer to pay large wages to a cook who could serve me acceptably, and a house-maid who would keep everything within doors in good order, leaving me free for my studies in botany and geology, and giving me liberty to write papers if I wish to, for a scientific magazine."

"Hear her!" exclaimed the minister's wife. "The dear lady speaks as one should who has had no experience of our difficulties. I am afraid she will discover before a great while that skilled cooks and trained house-maids are not to be persuaded, even by the lure of generous wages, to stay very long in the country, particularly in the season when there is most to do. Of course, where people have large establishments and can afford to keep eight or nine servants, the situation is different, but we who are sitting here must put our dependence on one or two, or three at the most. In fact, as I look around I do not observe a single woman in this group who has ever kept three servants at one time, and most of us have not the room to spare for more than one. It is not a question of paying money half so much as a question of inducing the women who might assist us in housework to come to our relief. The hotels and boarding-houses, and the cottages where summer people are camping out, attract, as we are aware, many of our own daughters who wish to earn money during the summer, in order that they may go to school and college in the autumn and winter. Some of us mothers would be glad to keep our girls with us at home, but the times are hard, other children are coming on who must be educated, and if the older sisters wish to take places where they are well paid and well treated, we cannot deny them the privilege. So it comes to pass that a majority of the mothers have too much to do during the hot weather. What was it that Mrs. Fay said about securing assistance from town?"

#### Unskilled Labor and Organized Charity

"By application to any responsible charitable organization," said Mrs. Fay, "one may always be put in touch with a mother who is more than glad to go to a situation in the country, if she may carry with her an infant or an older child. Such women are terribly handicapped in the struggle for existence. They may be widows, for many a poor man drops exhausted under the burdens he has to carry, leaving a helpless family. They may be wives whose husbands will fend for themselves during hot weather and make no complaint if they know that the poor, anemic children will come home plump and rosy at the end of the summer, or they may even be desolate creatures into whose past one does not inquire too closely. I have found that a mother with a child proves the best available help to be had by the ordinary housekeeper on the farm. The child soon wins its way to the love of the household, and the mother does her best and asks smaller compensation than she would if obliged to provide for her child in an institution.

"The other alternative is to accept the services of an elderly woman who brings with her a young cousin or niece, Danish, Swedish, French or German, at all events a friend or relative

unable to speak English except slightly, and very anxious to learn American ways. Such a young girl and such an elderly woman in combination have been most satisfactory in the household of an acquaintance of mine who was almost in despair over this disturbing problem."

#### Paying Guests

"I am taking boarders this summer," said Mrs. Doremus, "and I am doing it for a good reason, the obvious one that we need money. The cost of living, as children grow up in these hard times, confronts some of us in a threatening aspect. I have tried to simplify everything I could, but I told Edward last winter that, as the house would be full of visitors from June until September anyway, I might as well have it filled with visitors who would increase the income. A little while after Christmas I wrote to my city cousins, frankly disclosing my plans and explaining that for a year or two I must be inhospitable during the summer, although I would be very glad to have them come to see me at another season. I then placed my advertisement with a business agency, and I have filled every inch of my house with paying guests. Edward and I, with the little boys, are sleeping in one of the barns, which we have fitted up comfortably for the purpose. As we have electric lights in the house, running water, a bath-tub, modern sanitary arrangements and a telephone, I have felt justified in charging almost as much as the inn is accustomed to charge. I give abundant country fare in fresh fruit, rich milk and cream, good bread and butter, with my very best cooking, on the table, and I have always prided myself on keeping my home exquisitely neat and on having perfect beds. No city guest will find that she is obliged to rough it, and though the summer is not an easy one, I am getting along comfortably."

"You have your sisters who are always with you," said the doctor's wife, "and you of all people are independent of domestic assistance. I envy those guests of yours. They are fortunate, and if you choose to go into the business of accommodating summer people regularly, I foresee that you will have a waiting-list year after year."

"I am not quite so fortunate as my Cousin Mary in Vermont. It was she who gave me the idea, and she who convinced Edward and myself that it would be right for us to take this method of increasing our income. We were short of ready money, and Cousin Mary, when I visited her at Thanksgiving, suggested the idea to me. This summer she has had the good luck, I can call it nothing else, to have her entire house taken by a lady who wishes to entertain her friends in the mountains and to be relieved of all trouble in doing so. She has taken Cousin Mary's house for three months, and will fill it at her discretion with relays of guests whom she will entertain, while my cousin will carry on the entire management of the home, provide for the table and do everything precisely as if she were the keeper of a hotel. The payments will be made to her by one person, who is responsible for the entire summer."

"What a charming arrangement," said Mrs. Artrogge, "for both parties. I only wonder that nobody ever thought of it before. Very likely others have, but it is new to me. I have, it is true, heard of parties of Fresh-Air children sent successively to the country and paid for in that way, but this is the first time I have actually known that a woman in town has thus combined with a woman in the country and has been enabled to entertain her friends as if in her own house, without an extra burden to herself."

#### House-Parties in Midsummer

"I have been making a study in another direction," said Mrs. Madison, who had a bevy of young people in her home. "When Edith and Clarence returned from Cornell after their graduation, and Louise Emily, my dear adopted daughter, came home from Wellesley, I acceded to their wish that they should have all the company they wanted, if only they would stay at home with me. In the autumn they will all settle down to hard work of some kind. The weeks that are to come between now and then are to be for them a holiday. Clarence had an invitation to spend the summer in the Adirondacks and coach a pair of conditioned students. Edith might have gone to two or three classmates who wanted her, and Louise, had I been willing, might have joined a party, crossed the Atlantic and had a glimpse of the Old World. I have done without my young people, between preparatory schools and college, for a half-dozen years, and this summer I thought myself entitled to their society. They are to have several house-parties, and I have placed at their disposal the usual opportunities of a country house. There are golf-links within a reasonable distance, we have a tennis-court, and what with fishing, driving and tramping, and music indoors, I fancy the house-parties will be successful. Louise has carried on most of the correspondence. I remonstrated at first against hard and fast advice as to comings and goings, but she has convinced me that the present fashion of telling people when they are expected, how long they are to stay, when they will depart, and giving them every detail about boats, trains, etc., is superior to the vaguer and more elastic old-time ways. A friend of mine once went to spend a fortnight at a house in the mountains of New Hampshire. She had been asked by letter to go on a special day, but her hostess forgot that she was coming, invited other friends, and sent nobody to meet her at the station. When she reached her friend's house, she found a garden-party in full tide, and it was immediately evident to her that she arrived as a surprise. She had not been met at the station, and had taken a public conveyance to carry herself and her trunk. When the latter was deposited on the veranda, she felt embarrassed, and, though her hostess was most cordial, the guest could not help seeing that no arrangements had been made for her coming. I mentioned this to Louise Emily, and she said that if the invitation had been sent, as it probably had, several weeks beforehand and accepted, it was still incumbent on the guest to send a herald before her in the shape of a telegram, a letter, or some sort of message, so that the embarrassment might have been prevented. What do you think?" said Mrs. Madison, looking around the circle.

"I would not have stayed," said one lady. "The hostess was unpardonably negligent," said another. "Louise was right," remarked a third, and the third had right on her side.

When in this busy life of ours there has been any marked lapse of time between arrangements, either verbal or written, and their fulfilment, it is well to have an understanding. The guest would have placed her hostess hopelessly in the wrong had she returned without making her visit, especially as there was neither illness in the family, nor any apparent reason for imagining herself in the way.

Refreshments were now brought in, after which the club adjourned until the time appointed for another meeting.







# OUR YOUNG FOLKS' DEPARTMENT

Conducted by Cousin Sally



## A Square Deal

By Mary Minor Lewis



"It's nearly five o'clock," said John, flattening his nose against the window-pane, "and the postman hasn't come yet."

"And he ought to turn the bend in the road just before three," added Nina, crossly.

The rain, which had been coming down steadily for three days, blurred the window-pane where the two children stood watching for the mail-carrier. The wind dashed the branches of the cherry-tree—white with bloom—against the shutters until the shattered petals lay on the ground beneath like new-fallen snow.

"There he is!" cried Nina, as a little blue cart, drawn by a gray horse, turned the bend and jogged along down the road in front of "Willoughby Farm." He drew rein at the mail-box and climbed out as quickly as his rheumatism would let him.

The children grabbed an umbrella and raced down to the box.

After all the long wait, there were only three letters (and all for "grown-ups" who didn't count!) and the farm paper, which they opened as soon as they were back on the window-seat, turning eagerly to the "Children's Page."

There was a nice story which they read together, but which John finished first, because he was two years older and could read the hard words without stopping to spell them out. Then, while Nina was finishing the story, he read the letters from other children at the bottom of the page, guessed at one puzzle, and, just as Nina came to the end of the story, he caught sight of the "Prize Contest" in the corner of the page.

An offer of a handsome pocket-knife was made to the boy who should send in the best original drawing, and a box of beautiful paints for the best by a girl.

"Look, Nina!" he cried, "this is fine. Let's try for a prize!"

Nina agreed eagerly, and they got pencils and paper, and started to work at once.

Somehow, John's fingers seemed all thumbs; and every single drawing which he made was torn up and thrown into the waste-basket, because they were all without doubt very bad, indeed.

John had not the patience to keep on trying; and, as he crumpled his last picture into a ball and threw it angrily down, he looked over Nina's shoulder to see what she had done with her colored crayons.

She had drawn a picture of her speckled hen with a flock of little yellow chickens behind! It was really a very good drawing, indeed, for such a little girl; and their mother came to look, too, and said, "I think it is lovely, darling; and I hope you will get a prize. John must try again to-morrow."

The next day John had such a cold that his mother thought he had better stay in bed all day. So, after she had started Nina off to school, she brought up a lot of books and games, and put them on a table by John's bed.



"A lump rose in his throat; the hot blood of shame flushed his cheeks. He looked appealingly at his mother"

She brought him, too, some drawing-paper and some sharpened pencils, and said, "This is a fine chance for you to 'try, try again' to make a drawing good enough to send to the prize contest."

Then Mrs. Bemis went down-stairs to do her housekeeping, and John made several drawings which were even worse than those of the day before.

So, tired, he took an old story book out of his bookcase and had only turned a few leaves when he came upon just the kind of drawing that he wanted to make! It was a pen-and-ink sketch of an Indian crouching with bow and arrow behind a tree.

A sudden temptation came to John, as he looked at the Indian. Why not copy this picture?

In a few minutes he had, by putting a piece of tracing-paper over the sketch, made a very good copy of the crouching Indian. He made a ball of the piece of tracing-paper and threw it into the fireplace, slipped the book back into the bookcase, and called, "Mother! come and see what I have done!"

He only meant it for a joke at first, he fully intended to tell his mother the drawing was not really his own; but, when she seemed so pleased and said what a fine drawing it was, he could not bring himself to tell her that he had taken the picture from a book.

That evening both Nina and John mailed their drawings to the editor of the prize-contest department of the farm paper. It was some time before they heard anything, and during these days of waiting John grew strangely quiet. The more he thought about what he had done (and it seemed to John that he thought of it all the time), the more unhappy and ashamed he became, because he now realized that he had done a dishonest thing. He had taken something that did not belong to him! Instead of watching hopefully for the postman, as Nina did, he came to dread his coming! If his drawing should win the prize, then not only would he have done a dishonest thing, but he would be cheating some other boy out of what was justly his.

One day, as he was thinking of these things, Nina came running in with the mail.

"John! John!" she cried, excitedly, "I really do believe you have won the prize!" And she put a little box in his hand.

It was all too true! There, in its little case, was just the kind of a pocket-knife that John had always wanted!

A lump rose in his throat; the hot blood of shame flushed his cheeks. He looked appealingly at his mother. Tears were in her eyes! This was too much for John. He gave a sort of stifled sob and ran up to his room, to be alone in his misery.

It was some time before his mother came. Then she put her arms about him and said, "I have known all along, John. I found the tracing-paper in the fireplace. I have been waiting for you to tell me. Your father and I are anxiously waiting for our son to do the honorable thing."

John reached under his pillow and drew out an unsealed letter addressed in his round, boyish hand to the editor of the farm paper. He put it into his mother's hands without a word.

She spread the somewhat crumpled sheet before her. The letters were staggering and the spelling was uncertain, but John's mother was very proud of that letter, which read:

DEAR EDITOR—

I am a cheat. I took the picture called "The Crouching Indian" out of a book. It is not mine at all. I did not draw it, I used tracing-paper. I send back the pocket-knife. Please give it to the boy it belongs to. After this I am always going to stand for "A Square Deal." JOHN BEMIS.

## Letters from Our Boys and Girls

### The Letter-Box

DEAR COUSIN SALLY—

I enclose five cents for a club button. I've been thinking of writing for a long time, but have been putting it off.

We lived in the country until a few years ago. Papa moved into town so that we could go to school. I am in the sixth grade, and am ten years old. I suppose most of the cousins have heard of the national park that extends almost around Vicksburg. It has very fine monuments representing different states. The Illinois monument is the most beautiful. It cost \$100,000. Hundreds of people visit the park every month.

Your loving cousin,

MARGARET HENDERSON,  
Vicksburg, Mississippi.

DEAR COUSIN SALLY—

I received my "C. S. C." pin this morning with many thanks. I will try to be a loyal member.

Our school was out on April 19th. I am going to raise chickens this year if they will hatch. We live on a very public road, and the R. F. D. fellow goes within two hundred feet of our house. I have two thoroughbred Black Minorcas which I think I will take to the fair. We have a good many cattle, horses, sheep and chickens. I have a dog called Max. I am training him to drive cattle and to go where I want him to. We are not having very good weather. It rains about every other day. It will make the grass grow fine. I would like to exchange post-cards with some of the cousins. Hoping your club will prosper, I am,

Your cousin,

HERBERT WHITEHOUSE, Age Thirteen,  
R. F. D. 4, McConnelville, Ohio.

DEAR COUSIN SALLY:—

I received the club button and I think it is a beauty. Thank you so much for it. I live in the Cascade Mountains, fifty miles from any city and four miles to the nearest school. In winter there are from eight inches to a foot of snow on the ground.

With love to all, I am, sincerely,

HALLIE E. HILLS,  
Hazeldell, Oregon.

DEAR COUSIN SALLY:—

I have never written to the club before, but I want to, for I know I shall enjoy writing. I received my club button and was very much pleased, for it is so pretty!

I attend the Homer High School and am in the ninth grade.

I am a member of the Methodist Episcopal Church and Sunday-school. I also belong to the Junior League. I think we are getting along nicely with it. I love to work and try to help it along. I am the organist. I love

music and am going to take music lessons next summer. I am in the fourth grade in music.

I am fourteen years old and have always lived on a farm until last spring, when we moved to town. We are now living in our new house. Papa takes the FARM AND FIRESIDE, and we like it very much.

I would like to exchange post-cards with all the boys and girls.

MARION V. SABIN,  
Homer, Michigan.

### The Bulletin Board

The names of the prize-winners in our May 10th contest will be announced in our next Bulletin Board.

Nearly one thousand boys and girls joined our club during the past month.

Lizzie Brown, age twelve, of Woodford, Tennessee, is a very busy little girl these vacation days. She helps her mother cook, wash dishes, sweep and iron. I hope there are more girls like Lizzie!

Irene Martin is one of the busiest little girls in the club. She is taking music lessons and practises every minute that she can. By fall I expect that Irene will be playing some rather difficult "pieces."

Frances E. Wood, of Colorado, spends part of her time in the kitchen learning how to cook. Her first hatch of light bread turned out quite successfully. Frances is setting a good example to you, little girls!

Roy Sines, of Cumberland, Ohio, writes that he has a splendid black shepherd dog. Shep speaks for his meals, goes after the sheep, and carries small parcels in his mouth all the way from the village store! Shep must be a good dog!

Sewing! Sewing! Sewing! This seems to be Dorothy Zimmerman's "hobby." She makes all the clothes for her doll, which is nearly two feet tall, with big eyes that open and close! What is your "hobby?"

In exchanging post-cards, it is always well to send one of some interesting building, scene, or place in your home town.

Florence Routh, 311 South Meridian Street, Lebanon, Indiana, has organized a branch club and would like to hear from other cousins who have formed small clubs, in order to exchange ideas.

John Adams of Tennessee is learning to run his father's automobile.

Lillian Smith of Smyrna, Delaware, is busy making all sorts of articles for their church fair.

Several cousins complain that they have received very objectionable post-cards from readers. If there are any more such complaints, the full addresses of our boys and girls will not be printed on our page.

This month I will give prizes of splendid books, just the kind every boy and girl loves to read. To the ten girls or boys sending me the best verses on any of the following subjects: "The Daisy Field," or "The Old Mill," or "The See-Saw," or "My Pony," or "Our Picnic."

Do not send more than five verses. Write on one side of paper only, with your name, age and address in the upper right-hand corner.

All verses entered must bear signature of parent or guardian, to show that your work is original.

Contest closes July 29th. If you join our club the same time you enter contest, write your name, age and address on a separate sheet of paper.

Did you send for your club button? It costs only five cents, you know!

Cousin Sally's address is FARM AND FIRESIDE, 381 Fourth Avenue, New York.

DEAR COUSIN SALLY—

I have been wanting to join your club, but have not had time. Last Friday our school went to the Blanco Canyon. I climbed a mound surrounded by bluffs and on top we found some flint rock and bits of pottery. It is said that the Indians used to camp here a long time ago. On top of the mound were some holes, said to be Indians' graves.

We have a big incubator that holds 443 eggs. We have 130 little chicks. We have a big orchard. We live three fourths of a mile from town. Your little friend,

SIDNEY MEMFEE, Age Eight,  
Floydada, Texas.

\* \* \*

### Cousin Sally's Club

IF YOU have not already joined our club, I am sure you will when you read this letter from one of our members:

DEAR COUSIN SALLY—

Just a little while after I joined your club, I went on a visit to my aunt. In the railroad train, I noticed a boy in the opposite seat from me wearing a "C. S. C." pin. I jumped up in a jiffy and went over to him and whispered our pass-word—you know, our motto—in his ear. He started, looked up at me with his eyes and mouth wide open, and when he saw my club pin, which was right on my coat-lapel, he clapped me on the shoulder and said:

"So you are a 'C. S. C.' too?"

We had a dandy time all during the trip. When we parted, we promised to write to each other. About once every two weeks I hear from him. We are very good friends now. All because of your fine club, and I've always been glad I joined.

JACK HAVILAND,  
Belleville, New Jersey.

Now, wasn't that a jolly meeting? You had better join, too. Then, perhaps, the next time you go to town you'll meet some other little boy and girl who is a member of our club.

The button is five cents, and you can obtain one by writing to Cousin Sally's Club, FARM AND FIRESIDE, 381 Fourth Avenue, New York.

# Fashions for Summer Days

Designs by Miss Gould



No. 1636—Plaited One-Piece Dress

Pattern cut for 4, 6, 8, 10 and 12 year sizes. Quantity of material required for medium size, or 8 years, six-and-one-fourth yards of twenty-four-inch material, or four yards of thirty-six-inch material



No. 1637—Russian Suit with Side Closing

Pattern cut for 1, 2 and 4 year sizes. Quantity of material required for medium size, or 2 years, four-and-one-fourth yards of twenty-four-inch material, or two-and-three-fourths yards of thirty-six-inch material



No. 1555—Frill-Trimmed Tucked Waist

Cut for 32, 34, 36, 38 and 40 inch bust measures. Material required for 36-inch bust, two-and-three-fourths yards of thirty-six-inch material, with three yards of frilling three-and-one-half inches wide



No. 1553—Sailor Blouse—Adjustable Shield

Cut for 32, 34, 36, 38 and 40 inch bust measures. Material required for medium size, or 36-inch bust, two-and-one-half yards of thirty-six-inch material



No. 1554—Seven-Gored Outing Skirt

Pattern cut for 22, 24, 26, 28 and 30 inch waist measures. Length of skirt all around, 40 inches. Quantity of material for medium size, or 26-inch waist, five-and-one-fourth yards of thirty-six-inch material



No. 1558—Double-Breasted Plaited Waist

Cut for 34, 36, 38, 40 and 42 inch bust. Quantity of material required for medium size, or 38-inch bust, two-and-one-eighth yards of thirty-six-inch material

No. 1559—Three-Piece Skirt with or without Flounce

Cut for 24, 26, 28, 30 and 32 inch waist. Material required for medium size, or 28-inch waist, four-and-three-fourths yards of thirty-six-inch material. If the flounce is used, one-and-seven-eighths yards extra of thirty-six-inch material will be required



No. 1546—Tucked Waist with Dutch Neck

Cut for 32, 34, 36 and 38 inch bust measures. Material required for medium size, or 36-inch bust, two-and-three-fourths yards of thirty-six-inch material

No. 1547—Flounce Skirt with Drapery

Cut for 22, 24, 26 and 28 inch waist. Material for 26-inch waist, eight yards of thirty-six-inch material



No. 1797—Bathing-Suit with Princess Panel

Pattern cut for 32, 36, 40 and 44 inch bust measures. Quantity of material for medium size, or 36-inch bust, eight-and-three-eighths yards of twenty-two-inch material, or six yards of thirty-six-inch material, with one-and-one-eighth yards of contrasting material, thirty-six inches wide, for the trimming. This simple bathing-suit may be of black mohair trimmed with bands of striped linen in black and white, or in color

## How to Get the Patterns

If you want clothes that are right in style and yet practical, use the famous WOMAN'S HOME COMPANION patterns which we supply at the very low price of ten cents each.

So great has been the demand among FARM AND FIRESIDE readers for our WOMAN'S HOME COMPANION patterns that we have established three offices or depots from which these patterns can be obtained, as follows:

Eastern depot: FARM AND FIRESIDE, 381 Fourth Avenue, New York City.

Central depot: FARM AND FIRESIDE, Springfield, Ohio.

Western depot: FARM AND FIRESIDE, 1538 California Street, Denver, Colorado.

## A Premium Offer

To any FARM AND FIRESIDE reader who sends us one new subscription to FARM AND FIRESIDE with fifty cents for the same, we will give as a premium for the subscription one WOMAN'S HOME COMPANION pattern. To obtain a pattern without cost, send the subscription to FARM AND FIRESIDE, Springfield, Ohio.

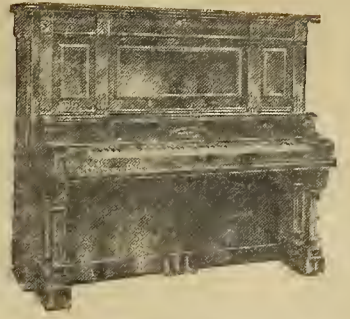

## Get Our Prices and Proposition Today

Your information about piano propositions is incomplete unless you have before you our RESIDENT FACTORY REPRESENTATIVE OFFER on Schmolter & Mueller Pianos. No offer has been so eagerly accepted as this. A Special Price and Convenient Terms to a limited number of purchasers of Schmolter & Mueller Pianos who act promptly in accepting this offer. A guaranteed saving of \$100.00 to \$200.00—payments as low as Fifteen Cents a Day—several years in which to pay—these are some of the attractive conditions under which you may possess for your very own a

Guaranteed

## Schmolter & Mueller Piano

Every state and territory contains pleased owners of Schmolter & Mueller Pianos—hundreds more each month are being added to our list of thousands of delighted patrons. You'll surely want to be the proud possessor of a Schmolter & Mueller Piano once you know our unique plan of sale.

Send your coupon to-day for Catalog and All Information.

## Schmolter & Mueller Piano Co.

Dept. J. F. F. 77 - OMAHA, NEBR.

Schmolter & Mueller Piano Co.

Dept. J. F. F. 77, Omaha, Nebr.

Send me Catalog, Prices and Terms on the Sweet Toned Schmolter & Mueller Piano.

Name \_\_\_\_\_

Address \_\_\_\_\_

# The American Magazine

## Offers You a Position

SOME important changes have been made in THE AMERICAN MAGAZINE'S Subscription Staff and we need at once an energetic man in every locality to act as our representative. The work is both easy and pleasant and does not require any investment of capital, yet yields big profits. Many of our representatives who are now earning from \$50.00 to \$200.00 and more a month originally adopted our proposition as a "side line." This is the kind of position that is open to you. No particular qualifications are necessary. We furnish complete instructions and keep in close touch with you. Send a postal for particulars. Better do it today before someone else gets ahead of you. Address Desk A.

Office of Subscription Staff  
The American Magazine  
381 Fourth Avenue  
New York

**PARKER'S HAIR BALSAM**  
Cleanses and beautifies the hair. Promotes a luxuriant growth. Never Fails to Restore Gray Hair to its Youthful Color. Cures scalp diseases & hair falling. 50c. and \$1.00 at Druggists.

I Trust You Ten Days. Send No Money. \$2 Hair Switch Sent on Approval. Choice of Natural wavy or straight hair. Send a lock of your hair, and we will mail a 22 inch short stem fine human hair switch to match. If you find it a big bargain remit \$2 in ten days, or sell and EARN YOUR OWN SWITCH. Extra shades a little more. Inclose 5c postage. Free beauty book showing latest style of hair dressing—also high grade switches, penpads, wigs, puffs, etc. Women wanted to sell our hair goods.  
Anna Ayers, Dept. A230, 22 Quincy St., Chicago

# The Farmer and the Camper

By Orin Edson Crooker

**T**HOUSANDS of farmers are situated where they could add a considerable amount of ready cash to the year's income by catering to the wants of city people who come to camp for a few weeks beside some lake or stream in their vicinity. For two months, July and August, the poultry-yard, the dairy and the garden could be made to "turn a golden furrow" if only foresight and head-work were used to bring these parts of the farm equipment to the best possible productiveness at this season.

The writer has camped for extended periods in Maine, New Hampshire, Vermont, New York and Wisconsin. Invariably he has been impressed with the lack of enterprise displayed along this line by most farmers with whom he has had to deal. Many a time he has sighted a barn or a house on the distant hills and visited it with hopes of securing vegetables or butter and eggs, only to find that "Our garden isn't any good this year; been too busy to look after it," or, "The hens don't seem to want to lay."

City people who go to the woods and lakes for a few weeks' outing often find that they must subsist largely on canned goods within sight of prosperous farms. This is like starvation in the midst of plenty. They are willing and ready to pay good prices for what they get; indeed, with a large number of them, the price of an article is of minor importance. They have usually gone to considerable expense to come from a distance; they do not wish their vacation spoiled for want of the necessities of life.

There are places where the camper does not expect to find the farmer equipped to meet his needs, and yet he often fares better in such places than he does in localities where well-tilled farms are the rule. More difficulty was experienced during a two-months' stay on a little lake in southern Wisconsin, where there were farms in all directions, than was the case during an extended sojourn in the wilds of Maine, where, to reach the nearest cow, a row of four miles was necessary. Less trouble was found in securing green vegetables in the heart of the Adirondacks, twenty-five miles from a railroad, than on Lake Winnesquam, near the heart of the summer-resort region of New Hampshire.

The fact of the matter is simply that the farmer as a rule has not awakened to the possibilities of the camper. July and August ought to find his garden filled with vegetables ready for the picking. He should have plenty of peas, beans, cucumbers, lettuce, summer squash and other things to meet the demands that will be made upon him. He should get his sweet corn into shape for those campers who prolong their stay after the middle of August. All these will bring good prices without protest from the pocket of the city man who has come out to "rough it" in a very civilized fashion. The farmer with a good garden finds himself deservedly popular with those who make up the summer colony in his locality.

Think of having to send to town for eggs and butter when in the midst of a thickly settled agricultural region! And yet this is just what many a city family has had to do when camping within sight of green pastures and within hearing of crowing cocks. Think of having to go a mile or more past several well-kept farms to get a quart or two of milk! And this in a so-called "dairy country." To be sure, this is a part of the experience of "roughing it," for the joy of which the city man pays his money. To a certain extent he does enjoy it, in that it adds

variety and is so different from having things delivered at his door—city fashion. But he never ceases to wonder why farmers who live near a summer colony should be so lacking in enterprise.

The camper has become a fixed feature in thousands of localities. In one way and another he spends a lot of money in the community. He is a good asset, for he pays cash on the spot. In almost every place that possesses an attractive lake or river he has built himself a summer home at a cost varying from a few hundred to several thousands of dollars. He has come to stay. In almost any such community some one or two enterprising persons can, in July and August, make a comfortable year's living by ministering exclusively to his wants.

It should be remembered, however, that while the city camper enjoys to a certain extent going after his produce, he is quite willing to have it brought to his door, and will usually pay a little more for it, without complaint, if so delivered. If the lake about which the summer colony is clustered is of fair size, it will probably prove a paying venture to invest in a small gasoline launch. With this means of speedy transportation at one's disposal, every camp on the lake can be visited each morning. A supply of vegetables can be carried along, together with butter and eggs. Orders can be taken for chickens to be delivered the following day. Bottled milk and cream might be carried in many instances. Enterprise will point the way to success, and soon determine whether it will pay to keep a few staple groceries on hand to meet the emergencies which arise in camp life.

As an instance of what can be done in this way, it is only necessary to cite the case of two young girls who opened a little store in Wisconsin near where a dozen or two rural mail-boxes had been erected by owners of camps down the lake. One or two launches from small hotels brought a few guests to the landing each morning to meet the rural carrier. The girls were enterprising and thought they saw an opportunity. Their store is open only two months in the year, but the two girls net about a thousand dollars each season, and almost every dollar comes from campers. Another year they expect to invest in a launch, take orders and deliver goods.

A farmer started in to supply a few summer cottagers with ice from his own ice-house—provided they would come and get it themselves. The demand grew to such proportions that he enlarged his ice-house and bought a launch. He spends three mornings a week delivering ice to the camps about the lake, selling all he can house in his present quarters at forty cents a hundred pounds. Each afternoon and evening he makes a trip with his launch around the lake, carrying passengers. His launch and ice-house pay him more than his farm.

Many farmers' wives take in washing from campers and make some money each summer in this way. It is money earned by the sweat of their brow in the hottest time of the year. In many cases these same women could, with less fatigue, make as much or more by the judicious handling of poultry for the summer-camper trade. Eggs and young chickens always bring fancy prices from the summer colony if strictly fresh. And any woman by use of an incubator, together with common sense and industry, can bring her chickens to the "frying stage" in plenty of season to meet the demand of the people who come from the cities—many of whom never see anything but cold-storage eggs and poultry the balance of the year.

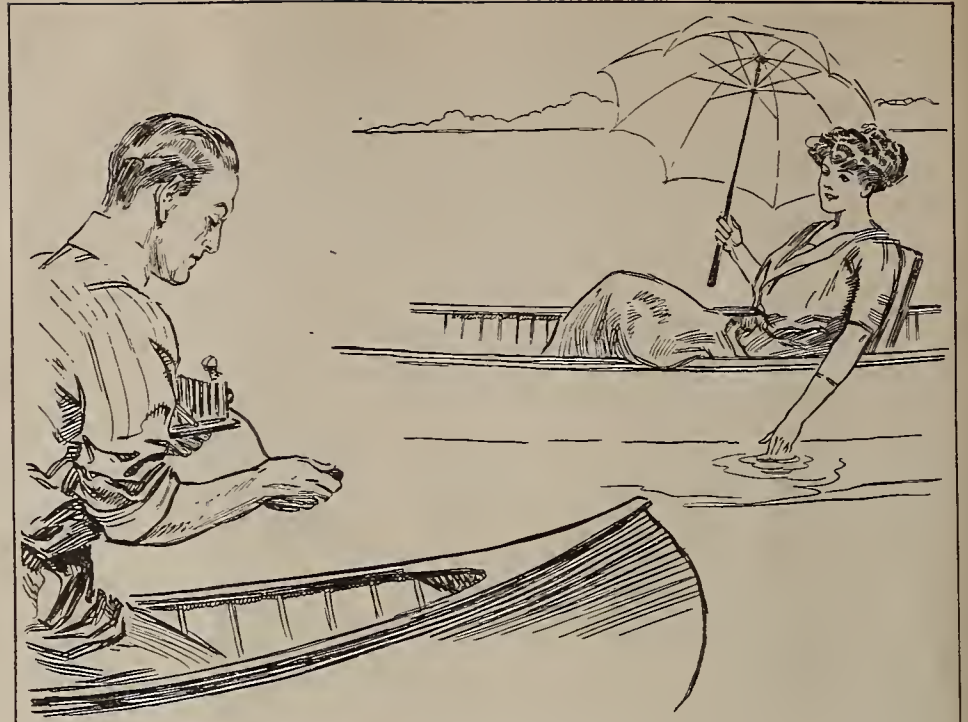

## Take a Kodak with you.

Make the most of every outing by taking pictures of the people and places that you are interested in. It will add to the joy of all the party at the time and give the added pleasure of pictures that you and your friends will always cherish.

And it is all simpler than you think. There's no dark-room required by the Kodak system of photography, and every step has been made so easy that the mere beginner can readily grasp every essential.

You can do every part of the work yourself or, if you prefer, may simply "press the button" and let some one else "do the rest."

And picture making is not expensive now-a-days. Kodaks from five dollars up and Brownie Cameras, (they work like Kodaks) at one to twelve dollars, offer a wide variety from which to choose. The Kodak catalogue, free at the dealers or by mail, tells all about them.

*If it isn't an Eastman, it isn't a Kodak.*

EASTMAN KODAK CO., 382 State St., ROCHESTER, N. Y.

## Just for Fun

### One Explanation

**YOUNG HUSBAND**—"Alice, these eggs are scrambled."

**YOUNG WIFE**—"Yes, dearie, the grocer said that the chickens that laid them were chased by a dog."

### Sacrificed

**SWEET GIRL** (affectionately)—"Papa, you wouldn't like me to leave you, would you?"

**PAPA** (fondly)—"Indeed, I would not, my darling."

**SWEET GIRL**—"Well, then, I'll marry Mr. Poorchap. He is willing to live here."—New York Weekly.

### Flattered

**MISTAH JACKSON**—"Yo hab a shape jest like a watahmelon."

**MISS JOHNSON** (coquettishly)—"Now, Mistah Jackson, you stop yo spuffin'. Yo suttinly do pay de most 'stravagant compliments ob any man Ah knows."—Puck.

### Smaller Sizes

**THE CUSTOMER**—"I think these Louis XV. heels are too high. Give me a size smaller, please—or perhaps Louis XIII. even would be high enough."—London Sketch.

### Found Out

**PATSY**—"Say, Chimmie, who was Robinson Crusoe?"

**CHIMMIE**—"He was de duck wot got a long term on de island."—St. Paul Despatch.

### Modern Farming

**CITYMAN**—"Do you keep bees?"

**COUNTRYMAN**—"No; there are more up-to-date methods of getting stung."—J. Collins.

### Wanted No Substitute

**"WHAT** is it, Bridget?"

"It's a fish, ma'am, and it's marked C. O. D."

"Then make the man take it straight back to the dealer. I ordered trout."

**Clean Food**

**Uneeda Biscuit**

It is an incentive to hunger to see Uneeda Biscuit made.

All materials are of the finest quality—clean, nutritious. The dough is mixed in spotless trays in a spotless bakery. Rolled thin; baked in wonderful ovens scientifically heated to give just the right crispness; then packed into the moisture-proof packages that keep them fresh, crisp and clean till eaten.

Never sold in bulk

**5c**

In the moisture-proof package

**NATIONAL BISCUIT COMPANY**

# FARM AND FIRESIDE

THE NATIONAL FARM PAPER



ESTABLISHED  
1877

JULY 25  
1911



How to Market Farm-Products is Important—See Page Six

**Let Me Pay the Postage on My Big FREE Book to You** This is just a little ad. but it will bring you my Big 1911 Book Free—postage paid by me. Show you over 125 styles and save you \$25.00 or up if you'll

**Write a Postal**

See my Split Hickory Auto-Seat, color illustrated in book. Prices will astonish you. All sold on 30 Days' Road Test—2-Year Guarantee. Also harness. Write me now.

H. C. Phelps, Pres.  
The Ohio Carriage Mfg. Co.  
Sta. 23, Columbus, Ohio



**The "Eli" King of Horse and Steam Power**

A train of followers, but no equals. Proves its superiority wherever it goes. Makes tight shapely bales, not loose bundles, works fast, avoids accidents and endures. Little draft, tremendous power. The machine that makes competitors tremble. Eli catalogue free.

Collins Plow Co., 1110 Hampshire St., Quincy, Ill.



**Gem City Business College**  
Quincy, Illinois

Annual attendance 1400. 23 teachers. Students from majority of states. Occupies its own \$100,000 specially equipped building. **Good Positions** await our graduates. Thorough courses in Shorthand, Typewriting, Bookkeeping, Actual Business Practice, Penmanship and Mathematics. Write for our beautiful illustrated catalog and year book free.

D. L. Musselman, Pres., Lock Box 14, Quincy, Ill.



**CIDER PRESSES**

The Original Mt. Gilead Hydraulic Press produces more cider from less apples than any other and is a **BIG MONEY MAKER**. Sizes 10 to 40 barrels daily. Also cider evaporators, apple butter cookers, vinegar generators, etc.

CATALOGUE FREE.  
THE HYDRAULIC PRESS MFG. CO.  
126 Lincoln Ave., Mt. Gilead, Ohio.



**WE SELL YOU AT WHOLESALE**  
Agents' Price One **AMERICAN Motorcycle or Bicycle**

We give 30 Days' Free Trial and Prepay the Freight. Write for our introducing offer and catalog and say whether you want Motorcycle or Bicycle. Do it now.

American Motorcycle Co., R. 505 American Bldg., Chicago



**WELL DRILLING Machines**

Over 70 sizes and styles, for drilling either deep or shallow wells in any kind of soil or rock. Mounted on wheels or on sills. With engines or horse powers. Strong, simple and durable. Any mechanic can operate them easily. Send for catalog.

WILLIAMS BROS., Ithaca, N. Y.

**THE LARGEST AND BEST LINE OF WELL DRILLING MACHINERY** in America. We have been making it for over 20 years. Do not buy until you see our new Illustrated Catalogue No. 15. Send for it now. It is **FREE**.

Austin Manufacturing Co., Chicago

**HAVE YOU ANY DRESS PROBLEMS** That Need to be Solved?

If so, why not write to Miss Gould, the Fashion Editor of The Crowell Publishing Company. She is always glad to answer any questions about clothes if a stamped and addressed envelope is enclosed for her reply. Address Miss Gould, care of FARM AND FIRESIDE, 381 Fourth Avenue, New York.

**ADMIRAL 2-MAN PRESS**  
3 FEET ROUND SELF FEEDER CONDENSING PACKER

ADMIRAL HAY PRESS



**AUTO-FEDAN HAY PRESS**

Only successful self-feed. 2 men can operate it. 20% less expense to operate. Record run 3 tons in 1 hour.

AUTO-FEDAN HAY PRESS COMPANY  
1507 W. 12th St., E. C., Mo.



**MONEY-MAKING** Farms throughout fifteen states; improved, one to one thousand acres, \$10 to \$100 an acre. Stock and tools included with many to settle estates quickly. Mammoth illustrated Catalogue "No. 34" free. E. A. Strout, Station 3058, Old Colony Bldg., Chicago, Ill.

**Milk Goats for Sale; Pure Swiss and Swiss Grades** Milkers and Young Does, Bucks and Buck Kids. J. S. Comins, R. 6, Box 64, Battle Creek, Mich.

**YORK STATE FARM LANDS** are fast being bought up by Western people. Great Dairy State—Great Future. Some rare opportunities now. Send for our catalog. Schultz & Hyer, Farm Agency, Binghamton, N. Y.

**O K CHAMPION DIGGERS**

Get all the Potatoes out of the ground in perfect condition. Our Two-Horse Elevator Digger saves time in your harvesting, and saves money on your own crop. We invite comparison with any others.

Free Large Illustrated Catalogue giving particulars, prices, etc., of our full line of Planters, Sprayers, Diggers, etc., on request. Write today.

CHAMPION POTATO MACHINERY CO.  
199 Chicago Ave., Hammond, Ind.

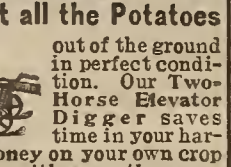

# With the Editor



HAVE just been reading of the wonderful polo game, in which the best American team beat the best English team at New York early in June. It was a splendid exhibition of horsemanship, and skill in the game, and nerve. For he who plays polo rides as if he either had no neck to break or wants to break it. The qualities that go to make a polo-player would carry their possessors through such a charge as that of the Light Brigade, or the equally valorous one of Fremont's Body-Guard.

But it is not alone in war or polo that nerve is required. Up in Wisconsin I have been told of a man who had a cow worth perhaps five thousand, perhaps ten thousand, dollars. She was his pride and the strength of his herd. She had been tested by tuberculin and found free from disease—and then, after a year or so, again the tuberculin was injected, and she reacted!

She had become tubercular, and was killed by the state. He got for her less than a hundred dollars—for the state does not pay fancy prices in such cases. And now came his exhibition of nerve. He had always been a believer in the tuberculin test, and the destruction of infected cattle. And he held to his principles. He readily assented to the action of the authorities. He said it was the best proof he had seen of the necessity of the law. This was not polo nerve, but it was pocketbook nerve—perhaps quite as rare a thing.

As I ride through the country, I see many orchards which are barren or unprofitable because their owners lack this pocketbook nerve—all over the East—especially in New England. These orchards are in grass or clover, and just before haying-time the owner has a struggle with himself. He knows that he should either plow down this vegetation, and restore some of the lost humus and nitrogen to the poor, starved soil, or mow it two or three times a season and pile it under the trees as a mulch. But hay is twenty dollars a ton or more, and the supply of cash is low. So he makes a skimpy crop of hay and turns what might be a good orchard into a mighty poor meadow. And sometimes he wonders why he can't grow as good fruit crops as grandpa used to grow. It is a lack of nerve—the nerve to remove the trees and make good farm land of it, or to leave the fertility to the trees and make a good orchard. He won't do either. He insists in fishing and cutting bait at one and the same time. He still hopes that maybe next year the land will succeed in mustering up strength to carry double.

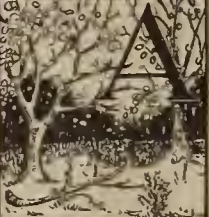

AND I've just been through such a sweat myself, but succeeded in coming off victor. Last summer we put the young orchard—two thousand trees—in corn, and, being the first year, I think this was not unwise, though when I saw the corn ten feet high towering above the little twigs of trees, I was uneasy. But the trees grew nicely.

After the corn was cut, we put the orchard in rye for a cover crop, to be plowed down in June. When June came, there stood the rye, tall and beautiful. It seemed a sin and shame to plow it down. The hay crop was a failure—our clover was not as big at haying-time this summer as it was in the stubble last September—it has been so dry.

We could mow the rye green for hay and save twenty dollars a ton on the hay we were buying. We could cut it for seed and save buying when we sow the corn ground for a cover crop this fall. About two thirds of it was plowed down, and the little trees already seemed smiling and clapping their hands at the nice feeling around their roots. Then my nerve failed as to the west orchard. I said, "John, I think we'll cut that rye in the upper orchard, and not plow it down." John looked relieved. He hated to "destroy" a crop already made. Like me, he felt as if we ought to eat that piece of cake, and maybe luck would open some way by which we could keep it, too. I slept over it, and in the morning I had a vision of those starved orchards of which I have told you. I saw that I was at the parting of the ways, and about to enter on the broad road of this year's profit and next season's destruction. So I went back to John and said, "J reckon, after all, we'll plow down the rye in the upper orchard."

"What'll we do for seed for the cover crop?" asked he.  
"We'll have to buy it," I replied, rather mournfully.  
"What'll we do for hay next summer, after the corn-fodder gets poor?" he queried.  
"We'll sow cow-peas," said I, "one drill width between each two rows of trees. Maybe we can get a crop that will make up the hay we'll have to have."  
I felt better. We may not succeed with the cow-peas, but we shall, at least, have maintained our nerve. That won't feed the horses, but it will feed the orchard.

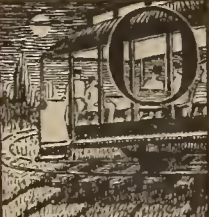

ON A scorching night in July, I journeyed by trolley from Dayton to Indianapolis. The mercury stood at ninety, and when the car stopped, the heat enveloped us like a hot blanket; but as we went, plunging along those quiet roads, between rows of silent, steady, brooding trees, in front of dark-windowed farmhouses, by black corn-fields and dim meadows, the fierce wind of our flight sucked the moisture from our skins and we felt cool. On the western horizon the sudden far glimmer of lightning palpitated in sheets of faint radiance. From the spinning trolley shot the darts of green fire that occasionally lit up the roadsides as if we had been a pocket-edition thunder-storm ourselves, and overhead blazed the lambent summer stars—while in myriads, over meadows and corn-fields, all the way, flickered the fireflies. I had never seen as many; and suddenly there came on me as never before the mystery and wonder of light. In those far-off stars something is happening which quivers down the ages and across the voids of space and does something to the eye which causes me to see. And in the distant cloud beyond the horizon, as on the rim of the whirling trolley, this same mystery occurs. But more wonderful than star or lightning is the light which the firefly sends forth—for it is something which the machinery of man cannot produce, light without heat.

Tennyson said to the flower plucked out from the crannies of rock that if we could know the blossom, all in all, we should know what God and man is. And as we rolled into Indianapolis, in the small hours before dawn, I thought that if we could know the firefly's light, all in all, we should understand lightning, and the star, and the spark from the trolley, and the secrets of the clime where there is no sun nor moon, nor star, but, nevertheless, endless day.

Robert Quirk

## Index to Advertisements

CLASSIFICATIONS	PAGE
<i>Automobiles</i>	
Chalmers Motor Company.....	9
<i>Carriages and Accessories</i>	
Boob Wheel Company.....	10
Century Manufacturing Company.....	10
Electric Wheel Company.....	11
Ohio Carriage Manufacturing Company.....	2
<i>Clothing and Boots</i>	
Eddystone Manufacturing Company.....	18
Woonsocket Rubber Company.....	9
<i>Correspondence and General Schools</i>	
Gem City Business College.....	2
Indiana Veterinary College.....	10
Engraving School.....	10
Page Davis Company.....	10
<i>Farm Engines</i>	
Fuller & Johnson.....	12
<i>Farm Tools and Implements</i>	
Champion Potato Machinery Company... 2	
Collins Plow Company.....	2
Dick Manufacturing Company, Joseph... 11	
Farquhar Company, A. B.....	9
New Process Manufacturing Company... 10	
<i>Fences and Fencing Materials</i>	
Bond Steel Post Company.....	11
<i>Fertilizers</i>	
Dupont Powder Company, E. I.....	11
German Kali Works.....	11
<i>Foodstuffs</i>	
Coco-Cola Company.....	24
National Biscuit Company.....	24
<i>Hair Goods</i>	
Ayers, Anna.....	13
<i>Hay-Presses</i>	
Admiral Hay-Press.....	2
Ann Arbor Machine Company.....	19
Auto-Fedan Hay-Press.....	2
Dain Manufacturing Company.....	12
Ertel Company, George.....	7
Kansas City Hay-Press.....	12
Spencer, J. A.....	7
<i>Household Miscellaneous</i>	
Hoosier Stove Company.....	15
Kirk & Company, James S.....	15
<i>Hydraulic Presses</i>	
Hydraulic Press Manufacturing Company 2	
<i>Land</i>	
McBurney Company, B. F.....	11
Sacramento Valley Development Ass'n... 7	
Schultz & Hyer.....	2
Strout, E. A.....	2
<i>Live Stock, Stock Foods and Remedies</i>	
Comins, J. S.....	2
McKallor Drug Company.....	12
Newton Remedy Company.....	7
Somers, Harold.....	15
<i>Patents</i>	
Coleman, Watson E.....	19
Farnham & Sues.....	19
<i>Publications</i>	
American Magazine.....	17
Curtis Publishing Company.....	8
<i>Pumps</i>	
Temple Pump Company.....	9
<i>Roofing</i>	
Barber Asphalt Paving Company.....	10
Edwards Manufacturing Company.....	10
<i>Separators</i>	
Sharples Separator.....	7
<i>Sporting Goods</i>	
American Motor Cycle Company.....	2
Aurora Automatic Machinery Company.. 20	
Mead Cycle Company.....	7
<i>Well-Drilling Machines</i>	
Austin Manufacturing Company.....	2
Williams Brothers.....	2

## ABOUT ADVERTISING

FARM AND FIRESIDE does not print advertisements generally known as "readers" in its editorial or news columns.

Mention FARM AND FIRESIDE when you write to our advertisers, and we guarantee you fair and square treatment. Of course we do not undertake to adjust petty differences between subscribers and honest advertisers, but if any advertiser in this paper should defraud a subscriber, we stand ready to make good the loss incurred, provided we are notified within thirty days after the transaction.

FARM AND FIRESIDE is published on the 10th and 25th of each month. Copy for advertisements should be received twenty-five days in advance of publication date. \$2.00 per agate line for both editions; \$1.00 per agate line for the eastern or western edition singly. Eight words to the line, fourteen lines to the inch. Width of columns 2 1/2 inches, length of columns two hundred lines. 5% discount for cash with order. Three lines is smallest space accepted.

# FARM AND FIRESIDE



PUBLISHED BY  
THE CROWELL PUBLISHING COMPANY  
SPRINGFIELD, OHIO

Branch Offices: 381 Fourth Avenue, New York City; Tribune Building, Chicago, Illinois  
Copyright, 1911, by The Crowell Publishing Company  
Entered at the Post-Office at Springfield, Ohio, as Second-Class Mail Matter

## A BLUE MARK

in the square below indicates that you are an old subscriber and that your subscription expires this month. Renew by accepting one of our offers before they are withdrawn.



## SUBSCRIPTION PRICE

One Year (24 numbers) 50 cents  
Canadian, 1 Year . . . 75 cents

Subscriptions and all editorial letters should be sent to the offices at Springfield, Ohio, and letters for the Editor should be marked "Editor."

Silver, when sent through the mails, should be carefully wrapped in cloth or strong paper so as not to wear a hole through the envelope.

Vol. XXXIV. No. 20

Springfield, Ohio, July 25, 1911

PUBLISHED  
SEMI-MONTHLY

Not more acres, but more from the acre.

The man with a garden can supply his table dirt-cheap.

Apples, especially the fallen ones, should never be fed to hogs as a single ration. The acid contained in the fruit prevents successful gains.

## Doctor Wiley's Scalp

THE Advertisers' Protective Association is sending out its war-cry against Dr. Harvey W. Wiley, Chemist of the Department of Agriculture. It emphasizes three things:

(I.) It is composed of advertisers whose advertising expenses are one hundred millions of dollars annually.

(II.) It proposes to bring pressure enough upon the government to get Doctor Wiley dismissed from his position.

(III.) It "seeks the support of the newspapers who are among the greatest losers" by Doctor Wiley's efforts to enforce the pure-food laws and to stir up public sentiment, and demands "a clean sweep of the Bureau of Chemistry and the appointment of those who place the business interests of the country above personal aggrandizement or personal prejudice."

The writer of the letter written FARM AND FIRESIDE underscores the words "awaiting your early reply."

Well, here is FARM AND FIRESIDE'S reply: It has long since decided that it does not want any of the hundred millions ready to be disbursed annually by advertisers of foods and medicines which are of the sort which come under Doctor Wiley's ban. We do not want Doctor Wiley dismissed. We think him a very useful and a very good man. We think he has made some mistakes, but as between calling a thing a poison or not when there is any doubt, we prefer the man who calls it a poison, and thus favors the lives of the people, rather than the "business interests." When Roosevelt wavered and appointed the Remsen Board to decide the benzoate-of-soda controversy against Wiley and in favor of the "business interests" which wanted to put that drug in foods, we believe Wiley was right and the Remsen Board and Roosevelt wrong. When Taft decided against Wiley's protest in the whisky case that a thing that had always been sold as something else might still be so sold, certain "business interests" were pleased, but we think that Wiley was right. And when it was decided that stuff called "saccharin" might be sold as sweetening by certain "business interests," though it has no food value at all, we think a swindle was authorized—notwithstanding the part the Secretary of Agriculture had in it.

Hoping this will find you the same, we remain, yours truly.

If you are too busy to notice the melodies of the birds and the tints of the wild flowers once in a while, you are working entirely too hard.

An early settler in eastern Nebraska planted a few armfuls of cottonwood twigs forty years ago. He has recently built a comfortable modern home in town with lumber cut from his grove.

A priest at Ohio, Illinois, is said to be working on a plan to merge all the run-down retail stores in that village into one department-store, and sell the stock in that to the consumers—mostly farmers. There has never been a time when the retailers by coöperation couldn't have met the competition of the mail-order houses on its own ground. Nor, for that matter, when the farmers couldn't have done the same thing for themselves.

## Tractors on Rural Roads

HERE is a load of 42,000 feet of green lumber going to market, a distance of twenty-four miles. It is a lesson and a prophecy. The lesson is found in the fact that, with reasonably good country roads, every farmer might have a railless railway past his door. On certain roads leading into London the farmers bring their loaded wagons to the roadside every morning to be picked up by traction-engines and hauled to the city in trains. The empties and return loads come back in the evening. Many mines send their trains of ore to market in this way with economy. In parts of the Appalachian Mountain fruit-region men have grown rich marketing fruit at railway stations many miles away, by this method. It is a thing which offers great promise through coöperation, if the coöperation be sanely under-

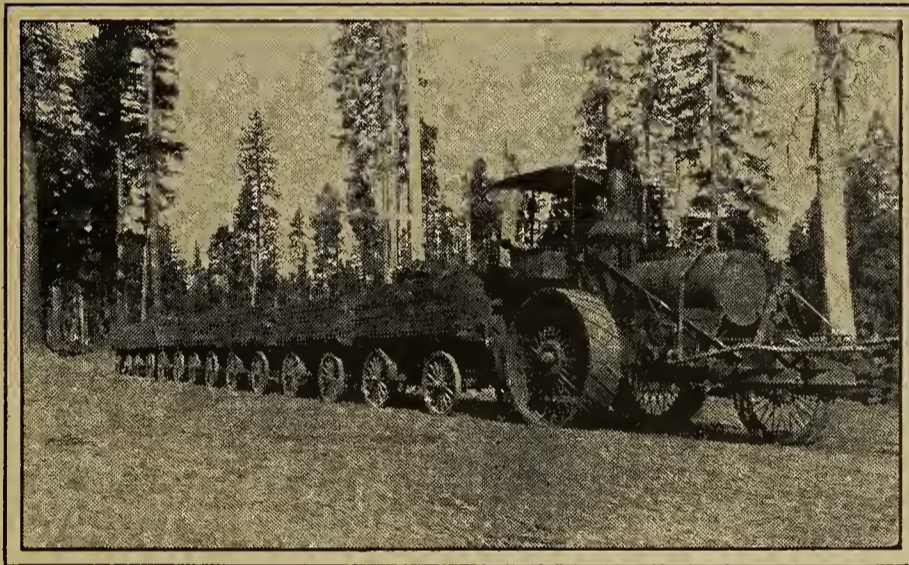

taken and worked out. To a great number of farmers good roads and traction-trains offer greater money benefits than are to be hoped for by any reform in railway rates which we are likely to succeed in bringing about, try as we may.

Plan now to have the roads all worked up and smooth, so they will settle before the early freezes.

Has neighbor Tom done a really good thing on his farm this year? Let him know that you have noticed it and warm the cockles of his heart. Then go thou and do a better thing.

## It Won't Do Any Harm

WELL, suppose we are wrong about the prospects for a fruit glut one of these years—and we hope we are; everyone must confess that there are grounds for pessimism. J. H. Hale, the greatest peach-grower in America, who is a coming factor in the apple and prunus fruit situation, says right straight out that the orchards are overset, and that there are breakers ahead. This is a turning of Mr. Hale's tune. And he is in the business for life and says he can't get out of it "except through the roof."

Now if Mr. Hale and the rest of the bears are right, it is a matter of life and death that the fruit-growers organize. They must organize to regulate marketing and keep up quality. They must organize to the end that if any fruit is to rot, it may decompose on the farm where it will have some value as fertility, and not on the markets where it will harm people's health and turn their stomachs.

Fruit-growers need to coöperate and place their marketing and packing in proper hands and their collective affairs under expert leadership.

If the storm breaks, coöperation is the only thing that will save the ship. If the weather remains fair—why, coöperation won't do any harm, even then, will it? Contrariwise, it will do us all an immense lot of good.

Most men are largely undiscovered country to themselves.

You cannot catch up with a lie by mounting another to chase it.

When you seek to show some people the other side of a question they act as if you were trying to stand them on their heads.

## "Doubling the Yield"

WRITERS for the newspapers and magazines, and even agricultural writers, are prone to tell how easy it would be to grow immense crops if the right methods were pursued. "Plant pure-bred seed," says the plant-breeder, "and you can double your yields." "Get a perfect stand," says another, "and you will double your yield." "Cultivate properly," says a third, "and you will double your yield."

All these things are important—quite as important as described. Good crops cannot be grown from poor seed, nor from poor stands even though the seed be good, nor by poor cultural methods, except by grace of God and the weather.

But unless the soil contains the plant-food for the crop, can a good crop be produced? Dr. Hopkins, in his great work, "Soil Fertility and Permanent Agriculture," states in substance that if there are a thousand pounds of nitrogen in an acre of soil, only twenty pounds can be taken up in one season by the plants. Out of every thousand pounds of phosphorus, ten pounds can be used, and out of every thousand pounds of potassium, the plants can get hold of but two and one half pounds. There are some peat soils that contain

less than three thousand pounds of potassium per acre, only seven pounds of which can be taken up per year, about enough for ten bushels of corn. The best seed, the best stand, and the best culture are powerless to produce more than ten bushels to the acre on such soils. What they need is potash.

We say that three fair ears of corn to the hill will give a yield of one hundred and fifty bushels to the acre. Quite true. But if you have the perfect stand, and the best seed, and the other conditions ideal, how are you to get the hundred and fifty bushels unless your soil will give up to the corn twenty-five and a half pounds of phosphorus during the season? Outside the phosphatic lands of some states there are few soils that contain the amount of phosphorus in the upper seven inches to develop a hundred and fifty bushels to the acre. It would take a soil carrying 2,550 pounds to the acre to do that. The average good farm in the United States has not half that amount of phosphorus to the acre. Such being the case, if Dr. Hopkins and the scientists generally are right, the corn crop is limited by lack of phosphorus, rather than by poor seed, poor stand, or poor tillage.

The man who seeks to produce the utmost must buy fertility, even in the corn belt. Whether or not it will pay to do this, depends on the cost of fertilizers as related to the price of crops.

There are optimistic investigators who take a less severe view of the plant-food question than this, but they have not as yet made their position good to the extent of making it safe to follow them. We all hope they may do so, but until they do, it is better to be on the safe side.

The safe side is to have a perfect stand, if possible; good seed; ideal tillage, if possible; and to find out what element of plant food the land needs, and whether or not it will pay to buy it. The very largest crops may not pay.

A Southern farmer grew 226 bushels to the acre in 1910. But it cost him forty-two cents a bushel in the field.

# The Headwork Shop

A Department for Handy Devices and Quick Ways of Doing Things on the Farm

## Makes Washing Easy

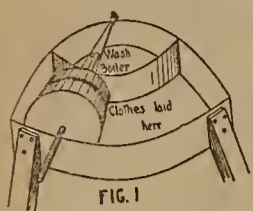

THE elliptical pan, which constitutes this handy washing-machine, is made of No. 20 galvanized sheet-steel, the rolls are wood and the long shaft driven into the front roll is three-fourths-inch galvanized pipe, forming the handle by which it is operated. The short shaft is made of No. 20 galvanized sheet-steel, something like a dinner horn, and is driven into the back roll. The long shaft, running through the cone shaft, has a swivel at the back of farther end. The cone shaft is connected to the gas-pipe shaft by a pin running through both shafts near the swivel, forming a universal point, thus allowing both rolls to revolve independently over uneven surfaces and yet revolve together.

Fig. 1 shows the machine as one looks at it. Fig. 2 is an end view partly cut off, showing the revolving rolls and the position of the oil-stove with two burners, one under each receptacle. In the bottom of the washing receptacle under the rolls is a curved

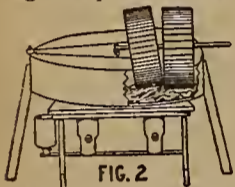

board perforated with one-half-inch holes to keep the clothes from burning and to circulate the hot suds. The blue-flame oil-stove keeps things piping hot. One-half gallon of oil will do a large washing. The minor details, such as faucets, leg pockets, and so on, are not shown in the sketch. As to size, one can have it to suit, mine is twenty-six inches by fifty inches, or one third of a circle, on each side. The rolls are twelve inches and thirteen inches, each with a five-and-one-half-inch face. The whole thing can be put away in a small space. MRS. JOHN BRUDY.

## To Trap the Hawk

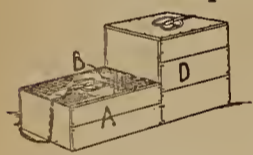

AFTER a marauding hawk had got in the habit of taking our young chickens, and efforts to shoot the wary bird failed, I constructed the box shown in sketch. The part D is boarded up, but the small run A is covered with wire netting, so that the chickens can pass out in view of the hawk.

Into this box I put a hen and three chickens, the hen being confined in the larger part. I set two steel traps, one on the wire cloth and the other on top of the box. The next morning I found Mr. Hawk in the trap which I set on the wire cloth. I hung him on a high pole over the chicken-yard and had no more trouble with hawks.

W. K. SHINN.

## "Out She Comes"

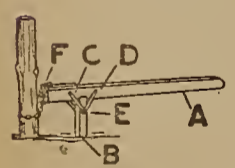

TAKE a strong cotton-wood pole (A), twelve feet long, three inches thick and three-and-one-half inches wide, and taper at end for lever. The lever post

(B) is two-and-one-half feet long, three-and-one-half inches in diameter and concave on top end so lever may work easily. Lever is fastened to lever post with four pieces of inch strap-iron bolted at C, D and E. A piece of wagon-tire, eighteen inches long, bolted on lever at F with the end tipped up one-half inch, serves as a hook.

Over this place a common trace-chain, looping it around the post, and hook it the proper length. One man can pull seventy posts an hour with this simple device.

A. L. GILLET.

## Sausage-Stuffer



THIS device can be fitted to any ordinary sausage mill or grinder. Have your tinner make a funnel of galvanized tin with a lip (L) to fit between tightening-plate (P) of mill and main part of mill. The neck (A) of the funnel should be seven eighths of an inch in diameter at the end and slightly larger at the funnel part. The length of the neck depends on length of casing to be filled. For casings from four to six feet long a six-inch neck is about right. The knives and plates are taken out of the grinder and the funnel put through the tightening nut or plate. Tie up one end of the casing and slip the other over the neck (A) till only a few

inches are left. Put the ground sausage-meat in as if you were grinding it, and as it fills let the casing gradually slip off the neck. ED. STOKER.

## Save Steps



HERE is a harness-peg made from an old buggy-step. Cut the square step off at the dotted line, and bolt or spike up in the barn where wanted, as shown in the sketch. It is also useful as a lantern hook. This makes use of some material that might have gone to the old iron pile from which there would likely have come but little financial return. The two uses given above do not begin to number the ways this simple device is of benefit.

WM. A. WEEDON.

## Chicken-Proof Flower-Bed

DO you want to know how flowers and chickens can be grown in harmony in the same yard? Here is a plan for a chicken-proof, cement-enclosed flower-bed that is not only beautiful, but serviceable.

As can be seen from the accompanying diagram, it is eight-sided, so for the form it takes eight common boards two feet long for the outside and the same number one-foot-and-three-quarters long for the inside.

The edges of these boards should all be beveled. Place the form in position, on a level piece of ground, and nail cleats across the top to prevent spreading. On the inner side of each outer board, nail a board eight inches wide by sixteen inches long. This makes a panel in the cement which adds to the general appearance. In each of the eight corners stands an iron rod, one inch thick and two feet in length.

Now pour in the mixture of cement, sand and gravel, reinforcing at the same time by placing iron wire throughout the form. In the course of three or four days, remove the form and wash the solid concrete with a thin mixture made of pure cement and water. Then string chicken-netting (one-inch mesh) around the iron rods, and you have an enclosure for an ideal flower-bed.

FRED. McNEIL.

## Evaporated Fruit Excels

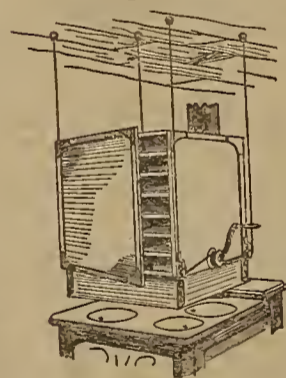

I NOTICED recently in FARM AND FIRESIDE a cut and description of a home-made fruit-evaporator, that comes near to one I patented July 10, 1886. However, it lacks the main principle: that of being raised easily from the stove. You see, by the date of my patent

it has expired, and I have no special interest in it, except to say that no family can afford to be without it, for evaporated fruit excels dried fruit every time. All kinds of fruits, sweet corn and vegetables can be evaporated in it with little trouble at no extra cost for heat. Fruit prepared in this evaporator excels in quality that which is usually offered at the store. The ordinary cook-stove forms the heater, and without interfering with the cooking, nor will the cooking interfere materially with the evaporator. By turning the crank, the machine is raised or lowered as may be desired, so the heat is regulated easily.

It will evaporate from one to three bushels of green fruit per day. W. F. HALE.

## Sectional Stack-Cover

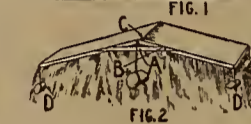

TO ROOF over hay or alfalfa stacks, make sectional canvas covers as shown in sketch. Fig. 1 is a frame made of six two-by-fours, each twelve feet long and two feet apart. The framework is covered with galvanized tin, extending over the edge

about four inches, on two sides. Fig. 2 shows two covers in use. A is a two-by-four fastened to the side two-by-fours of the cover by bolts at B. C is the galvanized tin extending over the joint of meeting, to keep out the rain. D D are weights to keep wind from blowing covers off the stack.

Stacks must not be smaller than roof, or wind will get hold. This saves enough hay in one season to pay for the roofs. You can put one cutting of hay on top of the other until it gets too high. You can use as many panels of roof on one stack as you care to, but fasten them together with a piece of two-by-four, securely bolted on each panel. JESSE RAHN.

## Fastening Poultry-Wire

WHENEVER more than one width of poultry-wire is needed in building a fence, a good way to fasten the strips together is with hog-rings. Bring the edges of the wire together and clinch a ring in about every six or eight inches. This is quickly done and the fence is made very durable.

J. L. ROBINSON.

## Holds Hay on Bad Roads



HERE is a plan to save many a tip when taking a load of hay over rough roads. Simply fasten a stout rope to about the middle of the binding-pole, and when you come to a tippy place, swing off on the uphill side and hang on to the rope. I often stand straight out on the side of the load. When necessary, there were two of us. We have never had a tip since we adopted this plan, although we have gone over the same roads where others have tipped.

A. D. ESTABROOK.

## Straighten the Trees



THIS is the most practical way which I have ever found to straighten young fruit-trees. Drive a stake in the ground three fourths of the height of the tree and about five feet from the tree. Now run a rope or small wire from a strong part of the tree over this stake and to the ground where you must anchor with stone or stake. The wire or rope must be doubled and padded where it circles the tree. Now insert a small stick between the wires and twist a little every two weeks or so. The result will be a straight tree in a comparatively short time. JOHN M. NEWTON.

## Corn-Huskers' Help

TO PREVENT one's wrists from becoming scratched and sore when husking, take the tops off a pair of woman's lace shoes, slip over hands, lace up securely and you will find it to be a great protection.

PRUDA B. UTLEY.

## Holding the Load

TWO sticks and a rope will save a lot of mishap. A is a wagon-stake, good and strong, about four feet long. B is a piece of round oak stick one-and-a-quarter inches thick and about one-and-a-half feet long. In Fig. 1 is shown the half hitch. In Fig. 2 is shown how it looks when fastened. To fasten it, put the strong quarter-inch rope (E) around C and then over the end of stick (B). E passes through a hole in B, as illustrated. C is a one-inch rope and is fastened

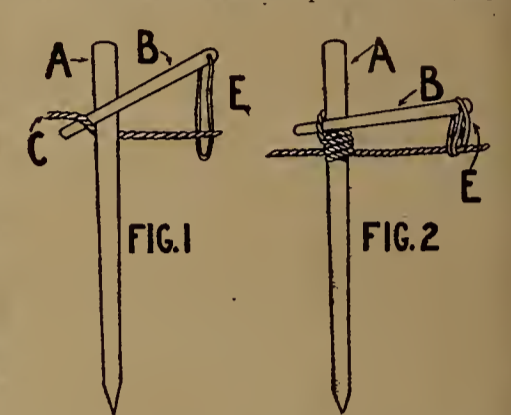

on both ends of the wagon in the center, and the stick (A) is put in the center of the top of the load. When you take the half hitch and turn the stick (B) around three or four times, the rope will be tight and the load will not fall off even on the roughest road. J. F. SOARS.

## To Carry Big Packages

FINDING the small bundle-carriers too weak for big packages weighing fifteen pounds or more I made a new variety by taking a piece of very heavy wire, putting it through the wooden handle of an old bucket and bending the wire bail-shape.

The ends can be hooked in the rope or cord lashings and the package carried easily. For very heavy packages, a harness snap fastened to the ends of a three or four foot strap will lash the package on the back, leaving the hands free. CLIFFORD E. DAVIS.

## A Pure-Water Cistern

THIS cistern is made with one side of the bottom lower than the other, and the drain-pipe is placed here, so that when it overflows the sediment will wash out. The inlet comes through a box-filter which keeps out the coarsest dirt. To the iron pipe of pump connect a piece of two-inch rubber hose long enough to reach the bottom of the cistern. Two inches from the open end of this hose is lashed a jug corked when empty, so that it will float on the water. This keeps the end of the hose near the surface, where the water is always clean. There is much satisfaction from the use of this device.

H. F. GRINSTEAD.

## Stove-Pipe Core for Chimney

SOME time ago a party in my neighborhood built a concrete chimney, using as core a stick of timber the size of flue wanted. But when the concrete was set, the core timber was content to "stay." So the chimney was taken down, intact, and placed on the stone-heap. In the making of a second chimney, I suggested that they use old stove-pipe of the needed size, shape and strength for the core—that it would not have to be removed.

This idea has proven so practical that I send it as a help to any wanting safe, economical chimneys, for house, shop or forge. Make a box or frame size and shape desired for outside of chimney and place stove-pipe inside as core, fill in between frame and pipe with concrete and you have a chimney.

T. VICTOR BRAYMER.

## A Practical Door-Stop

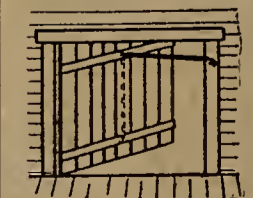

HERE is a handy arrangement to hold a door open without going outside to fasten back with a prop or hook. I take a good hard-wood broom-handle, cut it the desired length, put small staple in one end and in the other drive a heavy wire with end bent down, so as to hook in a staple in the door-frame. Staple other end to door at the top. When not in use, it hangs on the door. I use it on my cow-stable doors.

J. S. WALKER.

## To Our Readers—New and Old

The "Headwork Shop" is a collection of ideas that our readers send us showing ingenuity and gumption and knack. We say this for the benefit of the thousands of new subscribers who have been enlisted in Farm and Fireside's army since this feature was temporarily discontinued. Your ideas are wanted. So write and give the other readers the benefit of your experiences. Three prizes of five dollars each are given every issue for the three best contributions.

Our readers award the prizes by post-card vote. We want you on the voting list. Just mail us a post-card and tell which three ideas you think are best. Two weeks after the date of issue these votes will be counted and the prizes sent. Vote now on the ideas on this page. Won't you?

And if you have a handy way of doing something around the farm, write us a brief, boiled-down description of it, accompanied by a rough drawing, if one is necessary to make it clear. Address Headwork Shop, Farm and Fireside, Springfield, Ohio.





A SOUTHERN ROADWAY

## Our Homeseekers' Excursions



NEGRO SCHOOL

### IV.—The Hospitality of the South Beckons for Farmers

#### In the Trail of the Boll-Weevil

By James P. Harrison

I WANT to call attention to the quiet revolution that is taking place in the cotton country; to the obliteration of old lines and old sentiments, old habits and old customs; to the ending of the plantation life of the South and all that belonged to it, by the march of the cotton-boll weevil. I want the farming world to know that there are opportunities to acquire land, cleared and drained and ready for the plow, at prices that are lower than such lands can be obtained anywhere else in the world. Must this opportunity pass and these lands grow up, as they rapidly do, and return to the wilderness? It's the opportunity of a lifetime, a chance for a home, ready made; only needing a little patch-work to make the cabin into a cottage, to right up the fences and start the plow. The negro moves, and moves again as the weevil crowds him and his store credit is reduced, and the lands are tenantless and weed-grown. Most of the owners live in the city somewhere and would be glad to sell.

When the Louisiana land-holder is actually living on his land, he is trying to change from cotton to other crops, to live stock or fruit or truck, but almost every one of these men needs only a few years to put him out of business, because of his lack of knowledge in these new pursuits. Also, the lives of these men have been accustomed to more ease and luxury than their new vocations will allow or pay for. The opening for the small farmer is now.

#### Negroes Moving

There are good lands, not sand banks or clay hills, but deep alluvial loam soils that will respond to the first touch of the intelligent farmer. The negro has cropped a living and an eight to ten dollar rental out of them for years and years with no manure, no commercial fertilizer, no renewal except the enforced rotation of cow-peas and corn every third year.

I am a farmer, or, as we call ourselves, a planter, and, as the negro tenants left me, I fenced off and put cattle and sheep and hogs and mares and colts on the lands. I sold a bunch of steers right off the range to the butcher only a few days ago, fat and sleek. Speculators are already here and have bought, and are still buying, these lands. A foreign colonizing commission is now negotiating for the whole of my lands and all others that can be had near me at prices far below the value under the old rental tenant system. I know that it is better to sell all except my home farm than to let the land grow up again. I say these things to disabuse the reader's mind of any fear that I am seeking to make use of these columns for ulterior purposes.

The negroes will be improved by contact with the working white men, for they

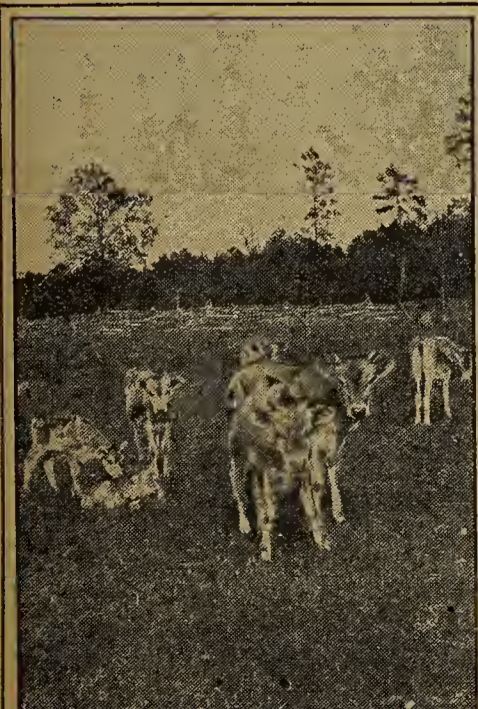

The stuff Arkansas dairy farms are made of. Conditions for dairying are good

do not improve where left to themselves in rural districts. I would estimate that two thirds of the negro population have already left and gone northward. More will go to the cities of the North and West which have so rapidly drawn others.

Now is the time to bring this matter to public attention, for at no period of the broad march of the weevil across the teeming lands of the cotton-belt will a more fertile land be devastated than this lower Mississippi Valley, land that readily raised a rental of eighty pounds of lint-cotton, some much more, lands with a soil of great depth, with drainage channels made by nature and only needing locks to be of use for transportation.

Should not such land be peopled by the best blood of the land, by the white man of native lineage and national sentiments? The immense tide of immigration flowing into Texas to-day is simply the response to the exploiting and advertising that is being done and paid for by the speculator who grabbed up the cheap lands after the boll-weevil passed over. These men are now reaping a harvest of dollars. Why wait for the speculator to do this in Louisiana at the expense of the immigrant?

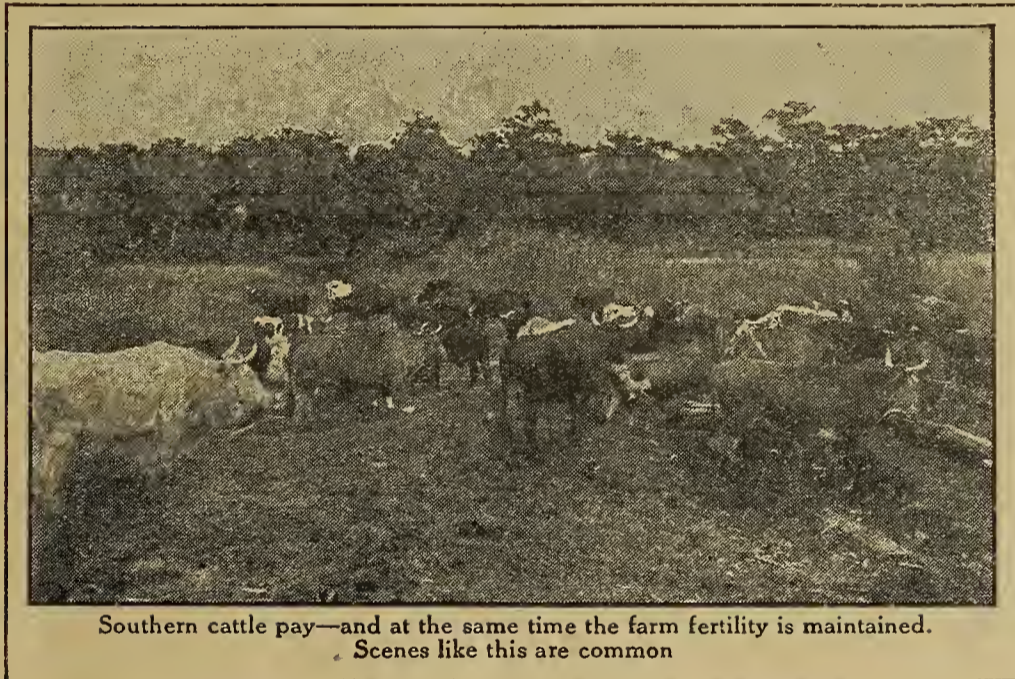

Southern cattle pay—and at the same time the farm fertility is maintained. Scenes like this are common

#### Optimism from Oklahoma

By E. M. Harrison

I NOTICE that every now and then someone bobs up and gives our plains a knock, saying that you can't make a living by farming in this high altitude. I wish to state that many of the writers of these letters are cowmen who resent the coming of farmers or "nesters," as they call us. Another trouble is that Eastern and Southern farmers come with their personal ideas of farming, which will not work out down here. You can't raise the big ears of white field-corn of the East and the oranges and figs of the South, for they won't grow. But you can raise forty bushels of milo to the acre worth sixteen to eighteen dollars, and you can raise 43,000 hog-melons on an acre which will fatten and keep at least twenty-five hogs.

Another thing, this is the healthiest country in the world; we have the purest air and water. We have only about ten inches of rain for the months of May, June and July, but this is all that is needed by the real farmer, who understands the philosophy of dry farming and the value of milo and hog-melons.

A Quaker settlement, eight or nine miles east of my farm in the center of the Panhandle of Oklahoma, has been here thirty years. These people have good homes, good farms, good teams and good stock. You don't hear them complaining. They are good farmers and have plenty of everything. They have learned to farm in this three-thousand-foot altitude and they often make two or three thousand dollars off melons alone. So in the future, when you read about this country being only good for sage-brush, prairie-dogs and coyotes, you will know where to place the writer. Land is cheap here, so I say to you who have no homes, "Come West."

#### What Arkansas Offers

By L. E. Wilcox

WE ARE right in the midst of peach-harvest now. We begin with the Sneed, after them comes Greensborough, then Triumph, Mamie Ross, Elberta and other varieties too numerous to mention, strung along until freezing weather the last of October.

I want the people of the Northern States to know what a fruit country we have down here, and how every farmer here with very little trouble may have fruit of his own raising on the table every meal of the year. Besides that, he can make fruit-raising a business.

#### Excellent Market Facilities.

We enjoy the special advantages for marketing, having the city of Hot Springs, Arkansas, with its thousands of visitors, all of whom must be fed, on the west of us; Little Rock, Memphis and St. Louis, with all the northern country beyond, on our north. Hot Springs is without doubt the best market of any city of its size in the United-States, because of its floating population, composed largely of wealthy

#### Clever People in Georgia

By H. N. Cochran

THE South is a great country. I do not think any other country on the globe offers a more inviting field for the homeseeker than does the South, and Georgia in particular. Here in "Middle Georgia" we have a healthful climate, a soil that responds handsomely to the intensive system of farming and repays the husbandman liberally for all the attention he may give it. The price is low, ten to fifty dollars per acre, with easy payments if desired.

We have rural mail delivery, churches, schools, and the like. We have as good water, freestone, as ever flowed from old Mother Earth. We have a lot of imported stock that will compare favorably with many other sections. Our people are hospitable and generous to a fault. To those who wish to engage in trucking; or poultry, our section is ideal. We have been in the poultry industry for a number of years, and can truthfully say that the field is an interesting one, and will repay the fancier a nice profit for his care. I purchased a bunch of White Plymouth Rocks the past season, especially to compare them with those of our own breeding, here in the South, and find ours far superior to the ones we got up North.

A friend from north of us paid our section a visit last fall and, after returning home, wrote us that Georgia was better adapted to the raising of clever people than anything else, if what he saw was a fair sample. He bought a home and is now living within a few miles of me.

#### Echoes

By Joel Shomaker

THE man who makes a farm on the prairie is a hero. He exhibits exemplary courage in facing the storms and defying the fires that sweep over the earth, leaving wrecks of human ambition. He subdues the wild and obtains dominion over meadows, fields and brooks. His work destroys miasma and produces a union of health, wealth and peace. Families of consumers bless his name, and transportation companies pay handsome dividends on earnings coming direct from the reclaimed prairie-land.

The man who makes a farm in the forest is a pioneer. He masters the giants of primitive ages, and transforms the wilderness into a garden of paradise. Surrounded by the enemies of habitation, hounded by wild animals and threatened by fires, he carves the pathway to riches, and creates a permanent residence and profitable source of income. He moves the wheels of commerce and supplies cargoes of world necessities in annual yields of abundance. He is a man of courage; the results of his labor benefit the world.

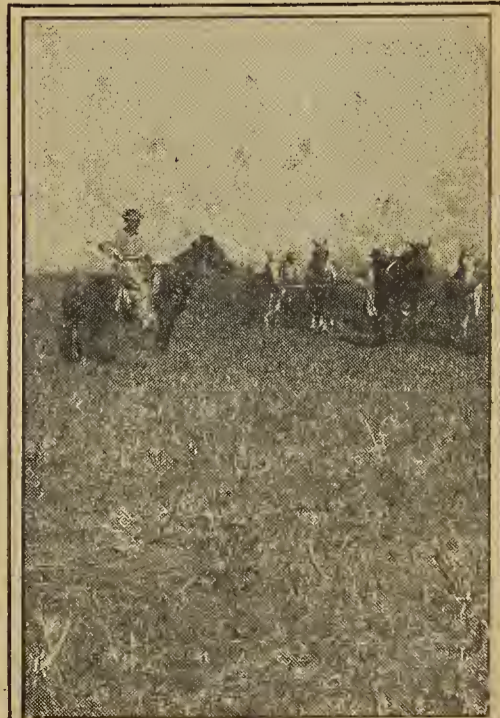

In Louisiana the rich virgin soil must respond to man's touch

# When To Sell Hogs and Corn

By Henry C. Taylor

Professor of Agricultural Economics, University of Wisconsin

**I**N THE region of highest farm values in the United States, corn and hogs are the mortgage-lifters. In the corn-belt a young man without capital who has strength of muscle, of mind and of character can make money, save money and become the owner of a good farm, first under mortgage and later free from debt. This requires strict attention, however, to the best methods in growing corn, in breeding and feeding live stock, and in marketing the products.

The relative value of corn and hogs determines whether the farmer should sell his corn or feed it to hogs. This is a matter which has to be decided many months in advance, or else, corn being low and hogs high, the farmer may have the corn and not the hogs to sell, or, corn being high and hogs low, he may have enough half-grown hogs to consume his corn, and the process started it must be continued.

## What Kind of Hogs To Breed

And again, the kind of hogs to breed may be determined in part by the relative values of hams, bacon and lard. The writer remembers the day he visited a hog-show and scoring exhibition held under the auspices of a swine-breeders' association. The work was carried forward by the judges of the scoring contest on the apparent assumption that there is an ideal type of hog best for all times and

corn-supply. This is not equally true of wheat. The wheat-crop of the United States is produced in seven or eight different climatic regions. The weather may result in a small crop in one region, while the other regions produce normal crops, or even above the normal; but if the wheat-crop of the United States as a whole is short, this shortage may be balanced by a long crop in some other country. Not so with corn. When the corn-crop is short in the corn-belt of the United States, the world's supply is short. This means that there should be a close relation between the supply and the price of corn in the United States.

## The South a Possible Corn-Belt

But nature has not set absolute limits upon the corn-area of the United States. The corn-region of the United States (Chart I.) is limited on the North and on the West by climatic conditions, but in the South the limit is set by an economic condition, the competition of cotton. Cotton and corn occupy the same positions in the system of crop rotation. They are both crops which can be cultivated while growing and which for this reason can be called cleansing and tilling crops. Without a crop of this kind it becomes necessary to introduce the summer fallow into the rotation. The purpose of the fallow is to give opportunity for cul-

that the corn acreage of 1910 was much greater than in 1908. In the United States as a whole the acreage increased 12.1 per cent. In Iowa the increase was 4.5 per cent., in Illinois 12.3 per cent.; while the increase was 16.6 per cent. in South Carolina, 15.5 per cent. in Alabama, 21.9 per cent. in Mississippi, and 45.6 per cent. in Louisiana. This shows that with rising prices the corn-area may be expanded toward the South, which will tend to meet the increasing demand for corn.

## How Corn Prices Rise and Fall

Chart II. shows the annual production and the monthly high and low prices of corn from 1900 to 1910. The top one of the two uneven lines represents the high price of corn; the lower one the low price of corn, for the years indicated at the bottom of the chart. The left hand lighter upright bar and the right hand dark bar represent respectively the acres and bushels produced on those acres for the years indicated. The corn-crop was short in 1901. The result was a rise in the price of corn (Chart II.). The 1902 crop was large, and the price fell back nearly to the old level (Chart II.). This is a striking example of the relation of supply to price, but a change in the supply is not the only cause operating to influence the price of corn.

From 1902 until 1907, corn prices showed no sensational tendencies. The price was always lowest after the season of corn-gathering and highest during the summer months. This seasonal variation in prices is normal. Corn weighs more just after harvest than it does later, and when sold by weight, the price should vary inversely with the amount of moisture it contains. The storage of corn involves loss from mice, rats and other vermin. The interest on the money one could realize from the corn if sold is another inducement to sell early rather than hold the crop. These and other factors tend to keep the normal price of corn lower after harvest than at other seasons of the year.

From 1903 to 1906 inclusive, the corn-crop increased from year to year. The crop of 1906 was as much above the crop of 1903 as the crop of 1901 was below that of 1900, and yet there was no marked change in the price level between 1903 and 1906. The demand had been increasing about as rapidly as the supply, hence little change in the price.

That a change had taken place in the demand is indicated by the fact that when in 1907 the corn-crop failed to increase as it had in previous years, and though the crop was the largest ever grown with the exception of the two preceding years, yet the demand had so increased that the upward trend of prices was more persistent in 1908 than it had been after the short crop of 1901.

From 1907 to 1910, the crop regularly increased. The increase was less rapid than was true from 1903 to 1906, and yet, while prices held steady with the increase of this earlier period, the prices gradually fell from 1908 to 1910. This all goes to prove that the demand for corn, as well as the supply, is more or less variable from year to year.

The demand for corn in the feed-lot of the farm on which the crop is grown is just as important, if not more important, in fixing the price of corn as is the demand for corn upon the city markets, where it is wanted for human food, for animal food, for exportation, and for the manufacture of beer, whisky, alcohol, starch, etc.

Taking the average for the years from 1900 to 1909 inclusive, 52 per cent. of the corn-crop was consumed within the country

# To Make Gains, Feed Weight

Some Comments by a National Authority on Feeding

**E**VERY once in a while one sees in the magazines or papers a statement to the effect that some scientist has succeeded in preparing food-materials in tabloid form which will furnish all necessary nourishment for man without any waste whatever, and the writer generally indulges in free flights of imagination with regard to the importance of the discovery for the future of the human race; how the necessary diet of a person can soon be carried around in one's vest pocket, and what an economy of effort will result from the general introduction of the preparation, both as regards the drudgery of housekeeping and the expenditure of energy in the digestion and assimilation of food. Armies will no longer have to be accompanied by enormous supplies of all kinds of food articles; a few pounds, perhaps, of the tabloid preparation will feed a regiment, and the soldier will march against the enemy with a firm step and a satisfied stomach, going where duty calls him, without thoughts or longings for the flesh-pots of Egypt, or the pie that mother used to make.

It is all very well to give one's imagination free rein occasionally, but it is not amiss, in fact, it is very desirable, to keep on earth with both feet and not to forget fundamental laws of physiology and hygiene in placing the horoscope for the future; and this may be stated definitely that the needs of man or beast for food will always be of paramount importance to the individual, and neither can be subsidized into ignoring the call of the appetite by flights of fancy or dribbles of special foods whose claim to recognition probably in the main lies in their fine-sounding names or in the skill with which their merits are placed before an unsuspecting and patient public.

## What is Food?

Let us look at the facts of the case and see whether there can be much hope that either man or animals can ever be sustained by feeding with pellets, even if these be composed of "food and only food." To take the simplest case, that of a human baby depending upon milk for its sole nutrition. If he behaves like a normal healthy baby, he will take, say, at six months of age, about a quart or two pounds of milk in the course of a day. This will contain about thirteen per cent. of solids, and he will receive, therefore, in all about four ounces of milk solids, practically all digestible. No argument or persuasive efforts on part of parents or manufacturers will convince him that a tablet or two of condensed predigested food will be enough for him. He wants what he wants, and if he does not get it, presto! there is trouble. The solid food substances of the milk, being made up of butter-fat, flesh-forming substances (so-called casein and albumen) and milk sugar, are easily and as completely digested as any food materials that can be secured, and still the little baby requires about two ounces of them daily to be happy.

A grown, fairly active man, if he should place himself on a milk diet solely, would consume some eight pounds of milk daily, containing a little over one pound of food substances, quite a bulky quantity of food, the equivalent of hundreds of food tablets, as we sometimes find them in drug-stores or in special preparations sent out by manufacturers of food articles. If one pound of digestible and easily assimilated milk solids is required by man, larger quantities of other food materials would be called for, in proportion to the amount of indigestible matter these contain, for he will require in all cases, about a quarter of a pound of protein in his food and a total fuel value of 3,500 calories. If he should select his food in the form of round steak, butter, potatoes and wheat-bread—all standard food articles and none too good for a steady diet—he would need, say, about thirteen ounces of round steak, three ounces of butter, six ounces of potatoes and twenty-two ounces of wheat-bread; that is, forty-four ounces, or over two-and-one-half pounds in all, if the results of dietary studies can be depended on to furnish us with accurate information on this point. These figures again fail to suggest that tablet-feeding of man will ever be either feasible or popular.

## Feeding Farm Animals

Applying the same method of reasoning to the feeding of farm animals, we turn to the information furnished by the carefully conducted scientific experiments on the food requirements of different classes of farm animals at different stages of growth or rates of production. We know just how much food the animal requires for maintaining his body weight at different ages and how much food it takes to produce a pound of gain in a steer, for instance, at the different periods of growth. We also know quite definitely how much food it takes to produce a pound of butter-fat by a dairy cow, and approximately, at least, how much food a horse requires daily to do certain amounts of work without losing in weight. This knowledge is within the reach of anyone who takes the trouble to consult standard works on the feeding of farm animals, and

[CONCLUDED ON PAGE 7]



Chart I.—Each dot represents 100,000 bushels. The corn belt is almost black because of the crowding together of these dots

all places. The relative importance of hams, bacon and lard was looked upon as if this were a matter which would never change, and as if hams were of first importance. It was assumed, moreover, that there was a particular lap of the ear and definite conformation of the nose which were essential to the ideal type of hog for the breed under consideration.

The type of hog best suited to one condition of the market is not best suited when prices change. There is no definite ratio between the price of hams and the price of side-meat. Last winter, side-meat was fifty per cent. higher than hams. Most readers will have the feeling of the writer that the ham has in the past been most highly prized in the judging of hogs. Is it not obvious that an increase in the value of side-meat without a corresponding change in the value of hams may make the "ideal hog" of the scoring match a rather absurd-looking animal?

Judgments with regard to market conditions have to be made long in advance if they are to be useful in the management of a farm for profit. Starting with the familiar notion that the changes in the values of products are due to changes in the supply or in the demand, every manager of a corn-farm can study with profit the causes which have brought about changes in the price of corn and hogs in recent years.

## The World's Corn Supply Comes from a Small Area

Indian corn is one of the important grain crops of the world. The number of bushels of corn produced is about the same as the number of bushels of wheat, but while the United States produces only about one fifth of the world's wheat-crop, we produce more than three fourths of the corn. The corn-crop of the United States was more than three billion bushels in 1910. This is the largest crop ever grown. About sixty per cent. of this was produced in eight states which comprise the corn-belt. Chart I. shows the location of the corn-belt. From this it will be seen that corn-production is so concentrated that weather conditions which result in a poor crop in a part of the corn-belt are likely to affect greatly the total

tivating the land, in order to clear it of weeds and bring it into good tilth.

Not only do corn and cotton occupy the same place in the field system, but they both require the attention of the farmer at the same time. This means that with a given land and labor supply the corn-crop can be increased in the cotton-belt only by decreasing cotton-production and vice versa. When

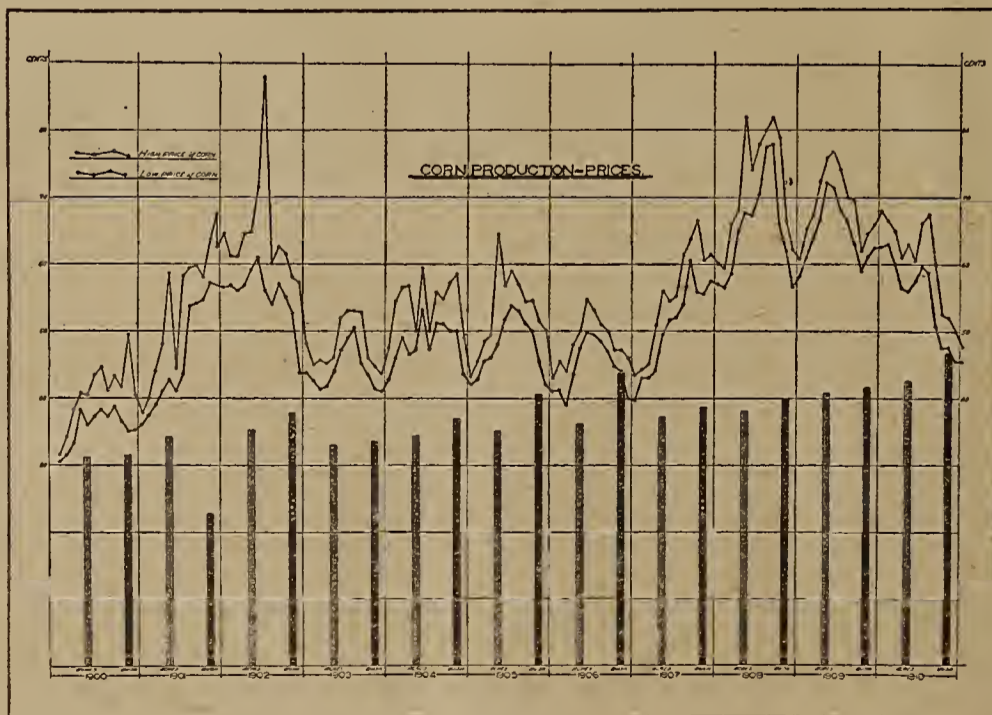

Chart II.

the price of corn is very high, relative to the price of cotton, the acreage of corn can be increased in the cotton-belt. It happened that the recent high price of corn came at the same time with the extension of the ravages of the boll-weevil into the cotton regions of Mississippi and Louisiana. These two forces operated together in making corn better able to compete with cotton. To these conditions in part is to be attributed the fact

where grown before March 1st of the year following its production. Twenty per cent. only had been sold and 38.2 per cent. was still in the hands of the farmer.

EDITOR'S NOTE—Professor Taylor has made a special study of the problems of marketing. The above article is the first one of two on the subject of the marketing of hogs and corn. The second will appear next issue.

## Live Stock and Dairy

### Typical Road-Horses



A HORSE that can travel ten miles an hour, three hours a day, day in and day out, is a good road horse. If he is handsome, true and sound, he is valuable. For many years but little attention was given to beauty and style. The trotting-bred colt that showed a good, clean gait and a propensity to go fast was invariably trained for track-work. Speed was the great essential, while conformation and style were considered of little or no consequence.

The stallion or mare that came under the wire to a record, were always considered the real thing to breed to, or from, no matter how angular might be their lines, or how ungainly their gait.

Therefore, a speed-machine was developed which, if capable to win the money, was valuable, otherwise almost worthless. True, there were families that retained and held their beauty and style in spite of this haphazard method of mating. The Mambrinos, Lexingtons, and Morgans particularly, came through the fire with their splendid characteristics still recognizable. The former, perhaps from the strong strain of thoroughbred blood in their veins, has ever proved the surest blood in the world to "breed on," even from the days of the great Eclipse, and, preceding him, from their ancestors who roamed in freedom the deserts of Arabia.

#### Morgans and Hackneys

The Morgan horse, whose origin is said to be shrouded in mystery, has ever shown this same breeding propensity. That "this or that horse is of Morgan blood," is a common expression made use of by horsemen when viewing an animal bearing the well-known characteristics of the Morgan.

These characteristics, and the fact that they are distinguishable in types that are related to the Morgan only in a small degree, would show to the unbiased mind that their ancestors sprang from the same source as the thoroughbred—namely, the steed of the desert.

A further proof of this, and to me a conclusive one, is that the prototype of the

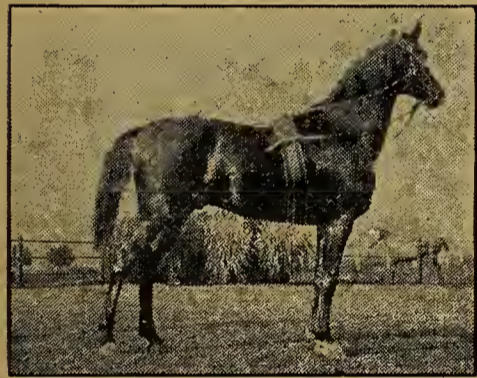

Naaman

The Pure-Bred Arabian Stallion. Note the flat bone, beautiful joints, full chest, oblique shoulders high and sharp at the withers, lengthy clean-cut neck, exquisite head, small tapering ears.

Morgan, the Hackney, and particularly those of the Norfolk strain, are direct descendants of the Arabian horse.

The Hackney breed has the same power to transmit its individuality; the characteristics are almost identical with those of the Morgan; in fact, in every way the two breeds show a close relationship.

It may here be well to define the points of a typical Norfolk Hackney, and allow the reader to judge whether or not they are identical with those of the Morgan. In doing this, I can offer no better description than that of Mr. Timothy T. Kissam, one of a syndicate of gentlemen who, for a term of years, leased for service in the state of New York the first Hackney stallion imported to the States. This horse, Bellfounder, a Norfolk Hackney, was imported in the year 1822. Mr. Kissam describes him as follows:

Imported Bellfounder had a small head and ears, full, prominent eyes, and wide apart; neck medium length, set well up from the withers; shoulders deep and oblique; deep girth and full-chested; fore legs well apart (not wide); short back, round-ribbed and very broad on the loin; hips wide and well gathered in; long, full quarters to hocks and short fetlocks; limbs strong and well-muscled, broad and flat below the knees and hocks; pasterns rather short; concave hoofs and open heels; tail and mane full-haired; had a large star in forehead, with diamond shape on end of nose or lip, one hind pastern white and a little white on the opposite forefoot at the heel.

Bellfounder stood a trifle over fifteen hands high, and weighed about eleven hundred pounds when in fair condition.

Does the above describe the Morgan horse

as a type? To my mind, it does so to a nicety. It also describes the typical road-horse, and horses bred of this type, providing they have a turn of speed, are, and have always been, valuable. It is a safe type for the shrewd breeder to raise for the market and, despite the popularity of the motor-car, will always net a handsome profit to the man who can produce them.

#### Morgan Blood Improves

Our government, in endeavoring to create a typical breed of American carriage-horses, has made no mistake in making use of Morgan blood. A genuine type of the Morgan stallion, crossed judiciously on well-bred upstanding mares, will produce horses of finish, action and style sufficient to grace the most elegant equipages of prince or millionaire.

Therefore, preserve the Morgan horse, and by doing so establish a breed of road-horses capable of traveling ten miles an hour, and

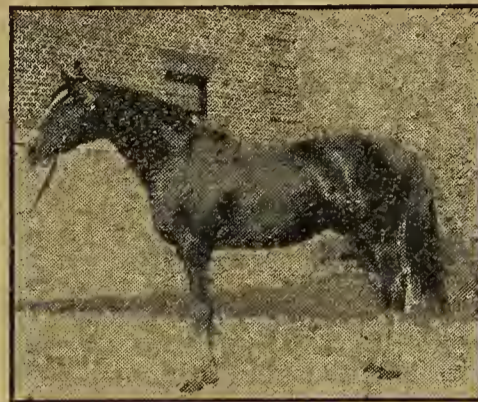

Salvatore

The famed race-horse. Note the long graceful neck clean cut at the throat; the lean bony head, and the small tapering ears, all inherited from the Arabian

of stepping away, without boots, when called upon, at a "thirty clip."

Every breeder within reach of a good Morgan stallion, or Hackney, can do his part with this end in view, and with profit to himself.

ALEXANDER MAIR.

#### Silage for Sheep

THIS is a feed that has been considerably discussed of late. Owing to the feeding of poor silage, and the feeding of too much of it, hundreds of sheep were killed when farmers first began to feed it. After losing some sheep, the ordinary man would discontinue the feed, never to use it again. As a matter of course, these men have not recommended it very highly, and a general prejudice has come up against its use.

But this is entirely unfounded; for silage, when fed right, can be made a valuable part of the ration, and, as its cost is small, it helps to make up a cheap ration. In the first place, it must not be fed in excessive amounts. Too much silage causes too much acid on the stomach, and is sure to cause trouble. Thus it should be fed only in limited amounts. Few feeders give more than one-and-one-half pounds a day. Silage that is put up in bad shape or that is molded in the least cannot be given to sheep, as it will be sure to result in trouble. Most of the men using it throw the poor silage aside and let it waste. In many cases the silage is given once a day, while hay or some other roughage is given at night. In the case of fattening lambs, the grain feed is thrown in on top of the silage.

When fed right, silage does the lambs good rather than hurts them. But recently I visited a plant where some 3,200 so-called pewee lambs are being fed. Handling this class of lambs requires a great deal of skill. In this case, part were not given silage, as the barns were too far from the silos. About half were silage-fed and the rest were not. During the past feeding season the loss among the dry-fed lambs has been heavier than the loss among the silage lambs.

The proving of the value of silage for sheep makes the silo more available for the general farmer. Formerly, we had the idea that it was profitable only for the dairyman, and so the man with a few cows could not afford to invest. Its value with beef cattle has been demonstrated. A certain amount must be fed each day to prevent spoiling, and so this becomes possible when the feed can be given to all the animals on a small farm that carries sheep as well as beef and dairy cattle.

C. A. WAUGH.

#### Hot-Weather Butter

MANY a farmer's wife, who is not so situated that she can get ice to use in caring for the milk and butter, knows how very difficult it is to make good butter through the hot weather. Several years of my life were spent on rented farms, where facilities for caring for the milk and butter were very poor. This was a constant source of worry to me through the hot weather. I finally evolved a plan that worked satisfactorily. First of all, I worked for cleanliness of the milk, the utensils and all other surroundings. I always managed some way to keep the milk in water.

While the cream-separator does excellent work, we had none and so used the old method of skimming. However, we did not

let the milk stand too long before skimming. We stirred the cream thoroughly and often, and if, on opening the jar, we found a scum on top, we took every bit of it off, for the least bit left in the cream simply meant strong butter. Several hours before churning-time we scalded the churn, then filled with cold water, and let stand till ready for it. When ready to churn, we drew off the water and went to work.

Just when the particles of butter were the size of wheat-grains, we stopped, drew off the milk, added a bucket of fresh water, churned rapidly a few times, drew off that water, and repeated the process until the water drawn off was perfectly clear. We then salted, worked and molded the butter before taking it from the churn. By stopping the churn when the butter is in small particles, the water can get to every part of it, and no milk is left to get strong and rancid. The grain of the butter is not broken and it takes very little working to get the salt through it.

Then we looked for a place to keep it after it was made. I got a granite kettle, large enough to hold a gallon crock, put the butter in it, covering with a lid. The lid was tied to the kettle, then the outfit swung down the well. When meal-time came, the butter was ready and convenient.

MARGARET D. COOK.

#### To Make Gains, Feed Weight

[CONTINUED FROM PAGE 6]

all our agricultural colleges are teaching their students these fundamentals. It is only necessary for the reader to put two and two together. Take, for instance, in the feeding of steers, the maintenance tables that have been constructed show that a one-thousand-pound steer at rest in the stable must receive somewhere about .7 pound of digestible protein and 7.2 pounds of digestible carbohydrates and fat a day, in order to maintain his body weight. The tables giving the total and digestible components of different kinds of feeding stuffs, on the other hand, show the quantities of these feeds that it will take to furnish the amounts of digestible food components given; if, for instance, hay and corn-meal are available for feeding the steer and we feed, say, ten pounds of hay daily, it will take an additional three pounds of corn to supply the necessary nutriment for maintaining the body weight of the animal, and correspondingly more of both feeds for producing a certain amount of growth. True, it is possible to do away largely, if not wholly, for a good while at least, with the roughage and to feed corn only, but there we have about the limit of concentrated feeding.

Few of our concentrated feeding stuffs have a higher percentage of digestibility than corn, and none would perhaps make a more satisfactory sole feed for a growing steer, if it were desirable to experiment in that direction. But it would take at least nine pounds of corn daily to furnish the amount of valuable food-materials required by a one-thousand-pound steer for maintaining his weight, and proportionately more for making a fair increase in weight. Not much tabloid food about that, is there? Of course, nobody has gone quite as far as that in the case of farm animals either, but many feeders are deceived by descriptions of the wonderful gains animals will make by the use of small amounts of certain special food preparations, which are not, as a general rule, foods, and cannot be classed as medicines.

#### Where the Absurdity Lies

It is no more feasible to fatten an animal on a couple of teaspoonfuls of a certain preparation than it is to satisfy the appetite of a man by giving him a few food tablets to eat. The two are of a kind, and the strange thing about it is that so many people do not stop to consider the matter for themselves, but blindly accept the representations of others. The thinking farmer should remember that there can be no substance a few ounces of which will make a healthy hog gain a couple of pounds, or treble the milk-yield of a cow, or make a hen lay twice as many eggs, no matter how positive the statements may be which he is asked to credit.

The above does not, of course, refer to well-recognized concentrates like oil-meal, dried brewers' or distillers' grains, gluten meal, or other highly concentrated feeds, the feeding of which doubtless in most cases would result in a marked improvement in the production or the condition of the animals. These concentrates are real foods and will produce results as regards gains in weight or yields, in proportion to the amounts in which they are fed to the animals. They are valuable feeds and not tabloid delusions.

F. W. WOLL.

Just because sheep will gnaw away and manage to live on the shortest pasturage about the farm is no indication that they will do their best on such grazing.

It is poor policy to turn cows out to rough it, as soon as they are turned dry, for a month or two in winter or early spring. This is the time they demand a good and regular ration. A cow is not going to do her best at the pail when calving-time finds her run down in condition.

## How the Matchless SHARPLES Tubular Cream Separator Proved it WEARS A LIFETIME

Were you thinking of buying some other separator to save a little in price? We tell you positively that the Tubular has twice the skimming force of others and therefore skims twice as clean. The Tubular more than pays back the difference in price every year.

Learn how the matchless Sharples Tubular proved it wears a lifetime. Ask us to mail you, free, the account telling how the Tubular did work equal to 100 years' service in a five to eight cow dairy, at a total cost of one dollar and fifteen cents for repairs and oil. The account contains pictures showing how the parts of the Tubular resisted wear.

You can have a Tubular—The World's Best—delivered and set up in your home, free—for thorough trial—without freight or any other expense to you. Contains no disks.

Other separators taken in part payment for Tubulars. Before risking anything on any inferior separator, see how much more the properly built, high quality Tubular will pay you. Write for catalog No. 112 and free trial.



## NEWTON'S HEAVE COUGH, DISTEMPER AND INDIGESTION CURE

The first or second \$1.00 can cures Heaves. The third can is guaranteed to cure or money refunded.



Makes the Horse Strong and Willing to Work. CURES HEAVES BY CORRECTING THE CAUSE which is Indigestion. Send for booklet "Horse Troubles." Explains fully about the Wind, Throat, Stomach and Blood. Newton's safe for colts, adult or mare in foal. A GRAND CONDITIONER AND WORM EXPELLER. \$1.00 a can at dealers, or express prepaid THE NEWTON REMEDY CO., Toledo, Ohio

**WE SHIP ON APPROVAL**  
without a cent deposit, prepaid the freight and allow 10 DAYS' FREE TRIAL. IT ONLY COSTS one cent to learn our unheard of prices and marvelous offers on highest grade 1911 model bicycles.

**FACTORY PRICES** Do not buy a bicycle or a pair of tires from anyone at any price until you write for our large Art Catalog and learn our wonderful proposition on first sample bicycle going to your town.

**RIDER AGENTS** everywhere are making big money exhibiting and selling our bicycles. We sell cheaper than any other factory.

**TIRES, Coaster-Brake rear wheels,** lamps, repairs and all sundries at half retail prices. Do Not Wait; write today for our special offer.

MEAD CYCLE CO., Dept. F-83, CHICAGO

**FREE** Literature will be sent to anyone interested in the wonderful Sacramento Valley, the richest valley in the world. Unlimited opportunities. Thousands of acres available at right prices. The place for the man wanting a home in the finest climate on earth. No lands for sale; organized to give reliable information. Sacramento Valley Development Association. **California** SACRAMENTO.

## FIFTY Beautiful Post-Cards Assorted Subjects for Farm and Fireside Readers

We have a small quantity of the beautiful Post-Cards recently purchased still in stock and we are going to give a set of fifty Post-Cards in our special gift proposition just as long as the supply lasts.

#### Write To-day for Particulars

We will reply immediately telling you how you may obtain this fine assortment of high-colored, high-finished, high-priced Post-Cards without a cent of cost to you. Write at once. Address

**FARM AND FIRESIDE**

Post-Card Department Springfield, Ohio

## BALE 18 TONS A DAY HAY

Our "Cyclone" 3 stroke self feed hay press is the latest, most powerful and most efficient press on the market. Each circle of the team presses in three charges. The self feed automatically puts the hay to the bottom of the bale chamber. These improvements wonderfully increase capacity of our presses. Write today for circular K-146 which gives prices and details of five days' free trial.

GEORTEL CO. QUINCY, ILL.

## There Is a Church In Which No Wedding Or Funeral Can Be Held

In which a sermon is never preached: which has no minister: no organ: no altar. Yet people from all over the world come to the church and love it and speak of it with gratitude. It was all the idea of one woman.

No one can read of this church but feels that there is a tremendous thought here.

Oddly enough, the church has hardly been written of. That is why the story, by the man who knows it better than any one else, strikes one with such a fresh interest.

It is in the August LADIES' HOME JOURNAL.

For 15 Cents You Have It

## A Woman Refused to Marry a Man

Yet she loved him: she loves him today. And it was all because she found she couldn't sit in a room with him except on a sofa beside him. But she believes she avoided the Divorce Court. And she sees there are scores of folks, some engaged and some married, who should do or should have done what she did.

She feels now she has found an "insurance against divorce:" she even calls it "my cure for divorce." It is a point of view on marriage that is unusual but marvelously true.

It is worth reading: this woman's story. She tells it herself. It is called "Why I Did Not Marry: and Why I Think Some Other Folks Shouldn't, Either."

It is in the August LADIES' HOME JOURNAL.

For 15 Cents You Have It

## Poultry-Raising

### Record of Ninety Hens

HERE is an account of what our hens did last year. We had a flock of ninety Buff Plymouth Rocks.

The receipts were as follows:

Jan., 67 doz. eggs, at 40c.....	\$ 26.80
Feb., 54 doz. eggs, at 30c.....	16.20
Mar., 72 doz. eggs, at 30c.....	21.60
Mar., 45 eggs sold for setting, at 60c.	2.25
Apr., 46 doz. eggs, at 25c.....	11.50
Apr., 75 eggs sold for setting, at 60c.	3.75
May, 61 doz. eggs, at 25c.....	15.25
May, 45 eggs sold for setting, at 60c.	2.25
June, 44 doz. eggs, at 28c.....	12.32
June, 42 eggs sold for setting, at 60c.	2.10
June, 61 lb. of fowls sold, at 18c....	10.98
June, 9½ lb. of chickens sold, at 25c.	2.38
July, 30 doz. eggs, at 28c.....	8.40
July, 15 eggs sold for setting, at 60c.	.75
July, 63 lb. of fowls sold, at 18c....	11.34
July, 4½ lb. of chickens sold, at 25c.	1.06
Aug., 31 doz. eggs, at 30c.....	9.30
Aug., 29 lb. of fowls sold, at 18c....	5.20
Aug., 55 lb. of chickens sold, at 25c.	13.75
Sept., 12 doz. eggs, at 36c.....	4.32
Sept., 23¼ lb. of chickens sold, at 25c	5.93
Oct., 25 doz. eggs, at 36c.....	9.00
Oct., 25¼ lb. of chickens sold, at 25c	6.43
Nov., 23¼ doz. eggs, at 40c.....	9.30
Nov., 61½ lb. of chickens sold, at 22c	13.53
Dec., 25½ doz. eggs, at 45c.....	11.47
Dec., 34¼ lb. of chickens sold, at 20c	6.85
Total .....	\$244.01

The expenses were as follows:

Jan. 1, feed on hand, 1 cwt. middlings..\$	1.50
Jan., 2 cwt. of wheat-bran.....	3.00
Jan., 9½ bu. corn, at 85c.....	8.08
Feb., 1 cwt. middlings.....	1.65
Feb., 2 cwt. bran, at \$1.55.....	3.10
Feb., 1 cwt. oyster-shells.....	.60
Feb., 52 eggs set at home.....	1.56
Mar., 10 cwt. of oats, at \$1.....	10.00
Mar., 10 bu. corn, at 80c.....	8.00
Mar., 1 bu. corn, at 85c.....	.85
Mar., 225 eggs set at home.....	5.62
Apr., 6 cwt. oats, at \$1.....	6.00
Apr., 6 cwt. of chick-feed, at \$1.....	6.00
Apr., 285 eggs set at home.....	5.70
Apr., 15 eggs bought for setting....	1.60
May, 115 eggs set at home.....	2.15
June, 8 bu. corn, at 82c.....	6.56
June, 4 cwt. scratching-food, at \$1.90	7.60
June, 50 lb. cracked corn.....	.80
June, 10 eggs set at home.....	.25
July, 2 bu. corn, at 80c.....	1.60
July, 8 cwt. cracked corn, at \$1.50...	12.00
Aug., 12 bu. corn, at 85c.....	10.20
Sept., 4 bu. corn, at 85c.....	3.30
Oct., 10 bu. corn, at 75c.....	7.50
Nov., 2 cwt. middlings, at \$1.55....	3.10
Nov., 2 cwt. wheat-bran, at \$1.35....	2.70
Nov., 12 bu. corn, at 70c.....	8.40
Nov., 100 lb. oyster-shells.....	.55
Dec., 1 bu. corn.....	.70
Dec., 6½ bu. corn on ear, at 30c....	1.95
Total .....	\$137.72

Leaving a clear profit of \$106.29.

The above account includes all fowls and eggs consumed in the family of five people, which we consider just as valuable as those sold, when home economy is practised. It shows what can be done on a twenty-five-acre New York farm, with poultry only as a side-line. While much has been said about the two-dollar and even nine-dollar hen, yet I believe it will take years of expert work to make those figures come true.

SYLVANUS VAN AKEN.

### Good Shelter Important

IN RAISING ducklings, begin by providing good shelter for them even before they are hatched. The houses need not be very expensive, but they must have good roofs and floors. Some people think that because ducks are water-fowls they should be able to endure any amount of dampness. This is a mistaken idea.

Colony houses are best for young ducks, because it is not advisable to keep large numbers together. But when building duck-houses, it is a good plan to have them built large enough to be used for sheltering the layers in winter if necessary. Ordinary coops have no place in duck-raising. Such coops can neither be kept dry nor clean. Needless to say, they are not suitable for any other poultry.

Have a separate yard attached to each house, and don't keep more than thirty-five ducklings in the same house. If the houses are small, fifteen ducklings is a crowd. Don't keep ducks of different sizes or varieties together. Fences need not be very high, as ducklings have no wings to speak of, until nearly full grown.

ANNA WADE GALLIGHER.

Keep the drinking-vessels in the shade these hot days. Even then it will be necessary to renew the supply of water often.

### Convenient Roosts and Nests

THE work of caring for the farm flock of poultry is reduced and made more pleasant by having the poultry-house fixtures conveniently arranged. It is small wonder that many farmers dislike the task of cleaning the poultry-house when the roosts are simply several poles nailed across one end of the house, and the nests—often nailed to the wall—are frequently used as roosting-places by the hens. In such a house, lice and mites are apt to reign supreme, and the unfortunate wight who has the job of cleaning up will come out with a creepy feeling from head to foot and hatred in his heart for the whole feathered tribe. Such houses are the result of that old notion to which some farmers still cling, that chickens "don't pay," and are merely tolerated as a sort of necessary evil. But chickens do pay if they are given proper care. This is particularly true of farm flocks, for they pick up a good share of their living around the barn and corn-crib during the summer months.

One of the chief requisites of success is clean quarters. A conveniently arranged house is least likely to be neglected, hence it is important that roosts and nests be constructed and arranged properly, as they are the main fixtures. Roosts require frequent oiling or whitewashing in order to keep vermin in check. If they are removable, it is an easy matter to keep them clean. One of the most satisfactory plans is to make the roosts of two-by-four scantlings, the ends resting on notched cleats at each end of the platform used to catch the droppings. By giving the ends and under sides frequent attention, there should be no trouble from lice. There are various swinging, self-oiling and other patent roosts, the use of which is promised to keep the house free from vermin; but the fact remains that whatever sort of roost is used, we must be eternally vigilant to keep the lice and mites from getting ahead of us. If it is preferred to have the ends of the roosts away from the wall, they may be shortened and nailed to boards eight inches wide and long enough to accommodate the required number of roosts. The boards rest on the platform and, for cleaning, the entire roost is lifted off.

Hens detest filthy nests, and will not lay in them if they can find a better place. Nests nailed to the wall are an abomination, for they afford an excellent hiding-place for lice, where it is difficult to get at them. As a rule, we make our nests in sections of three each, each nest being fifteen by twelve inches and twelve inches high. They are placed beneath the platform, and, as they have a removable top, it is easy to gather the eggs. As the nests face the wall, the hens never get into the habit of roosting in them. We examine the nests frequently to make sure they have not become infested with lice. A handful of air-slaked lime is placed in the bottom of each nest-box, and when nesting-material is renewed, it is sprinkled with insect-powder. By using these precautions we have little trouble with lice or mites.

NAT. S. GREEN.

### Hen-Proof Chick-Feeder

NEARLY everyone has trouble with hens eating feed away from the little chicks. This feeder here illustrated is divided into two parts, feed-bin and yard. The bin is provided with a feeding-hopper so there will

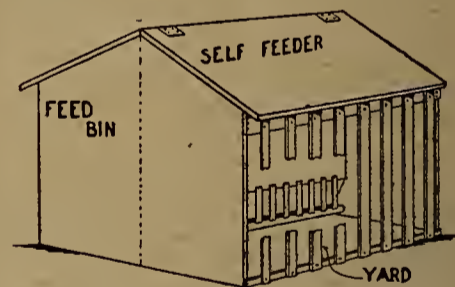

be feed before the growing chicks at all times. In front of the yard nail slats close enough together to allow chicks to pass through, but to exclude the hens.

Also nail narrow strips across mouth of bin to prevent chicks from scratching out their feed. The central portion of the four large slats on the left-hand side has been omitted in the sketch so that the feeding-hopper may be more clearly seen.

J. F. BAKER.

If soft, moist food is given to chicks in hot weather, see that they eat it up clean at once.

### A Point for Bronzes

HERE in southeastern Missouri, turkeys bring so much per pound without regard to the kind, size, shape or color; therefore, we raise the kind that will weigh the most with the least amount of feed and care. The Bronze and the White Hollands are the general favorites here. Some prefer the White Hollands because they are tamer than the Bronze and almost as hardy.

Personally, I prefer the Bronze because their color enables them to hide from their enemies more easily. This is the turkey's only protection. You all know how little quail hide themselves; turkeys do the same thing, but if they are white, they cannot hide so well.

MAY FULLERTON.

## Garden and Orchard

### Starting the Peach-Orchard

A TENNESSEE subscriber on a clay soil farm is about to start a peach-orchard, and wishes advice as to the best varieties to plant and the general method of procedure. He meets difficulties which are common in that section and which are not unknown elsewhere.

Beginning with the location: Wherever there is a tendency to late frosts, it is best to use a place for the orchard where the slope of the land is toward the north or east, rather than south or west, on account of there being less tendency for too early growth and blossoming in the spring.

The peach is not so particular about the kind of soil as some trees, providing there is excellent natural or artificial drainage. Where the water remains near the surface, held there by impervious subsoil, and the surface soil is kept cold and soggy in consequence, there can be no success expected with peaches.

Unless one is quite familiar with the budding and grafting, or has a person in reach who is successful in this work, it is better to buy the trees already budded. This will save about two years' time in getting a producing orchard, which is quite an item.

One certainly should not dig a hole and fill with manure in which to set trees. Where this is done, the contact with the manure has been found to induce fungus diseases on the roots and leaves, and do injury to the trees later.

Where the land can be cultivated, it is of advantage to plow the land deeply the fall before planting, and harrow and fit it as for corn or potatoes as early as the ground can be worked in the spring. It is then necessary to dig the holes only large enough to receive the roots of the trees. After plowing, one should apply a fairly generous coat of manure broadcast over the field, during the winter, and in the spring work it into the soil thoroughly with a disk-harrow.

In ordering trees, get those that are from four to five feet high which are well-branched and will caliper five-eighths inch or more in diameter, and order only from well-known nurserymen. It is of advantage to order as early as possible in the fall, getting a written guarantee of the nurseryman when the trees will be delivered to you and that they will be free from all diseases.

Among the varieties best adapted for local marketing in your section are the following: Greensboro, Waddell, Carman, Mountain Rose, Early Crawford, Belle of Georgia, Elberta, Steven's Rarieripe. A list of peaches adapted to shipping has been recommended which includes Carman, Mountain Rose, Belle of Georgia, Old Nixon and Elberta.  
B. F. W. T.

### Gardening in the Back Yard

MEET them often, the people who have become sick of the confines of a closely built-up city. They do their work in factory, store or bank, have all the good things that a city affords, live in a house which may be comfortable in its way, but which they do not feel like calling "home." For what is home without a garden, without free space around the house, and some trees or a bit of green lawn? Then some of them come out to our suburban community, rent or buy or



There is profit in work like this

build a house. We see them go at it with evident enjoyment, planting their little gardens. It is not so much the actual saving of expenditures for green stuff that counts with them. It is the change, the poetry, the convenience. The radishes and the lettuce and the strawberries, etc., all taste better, both actually and in imagination, for being produced at home, by one's own efforts; and you can have such things when you want them, fresh from the garden, not as you may buy it, in wilted condition, from the store. I feel young when I go out in my garden. It is not so bad to be "the man with the hoe."  
T. GR.

### Winter Rhubarb

A NEW HAMPSHIRE reader asks for information concerning winter rhubarb raised on a commercial scale.

In a general way, commercial rhubarb differs very little from its production for home use. The forcing-place, whether house-cellar, root-cellar or structure built entirely above ground, must be frost and light proof, and the warmer it is naturally, the less artificial heat will be required. Any kind of cellar bottom (brick, cement or earth) will answer. The space for the rhubarb should be filled with good loam soil. All the soil possible should be taken with the roots when dry and thoroughly frozen in this condition before placing in the cellar. Set close together on cellar bottom, filling spaces with good loam. Occasional narrow passages should be left for convenience in going through, but otherwise the closer the clumps are set, the less the space required.

For insulation purposes, one thickness of a good roofing-material will answer, but double will be better. If the roof is not too steep, it may be covered with coarse manure or straw. Wyatt's Victoria is the best variety for forcing, on account of color and habit of growth; any variety, however, will answer.  
J. E. MORSE.

### Irrigation for Truck Crop

I AM asked by an Oklahoma subscriber how much of a truck crop can be irrigated with a well capacity of 2,500 gallons per day and a 7,500-gallon storage capacity in underground and gravity tanks. A gasoline-engine capable of pumping 750 gallons per hour to the land to be irrigated is at his disposal.

It is rather difficult to give definite information regarding the amount of water necessary to irrigate an acre of ground since conditions vary so greatly throughout the different sections of the United States. The soil, rain and humidity largely determine this question. However, under ordinary conditions approximately 18,000 gallons of water are required to thoroughly irrigate one acre of vegetables. This is more particularly true of sandy soils that have been heavily manured.

With a water-supply of 2,500 gallons, one can thoroughly irrigate one seventh of an acre per day. If only two applications are necessary per month, two acres can very easily be cared for.  
C. C. VINCENT.

"Dry a few cherry-leaves," says a contributor, "before they are all dead, and store them away to season rhubarb pies with during the winter. They give the pies almost the identical flavor of cherry pies." Worth trying.

### To Cure Wormy Cherries

AN INDIANA subscriber has a cherry-orchard, the fruit of which is wormy. He asks what to do, and how and when to do it, in order to save the next crop.

The insect that is responsible for the wormy condition of cherries is the plum-curculio. This insect damages all stone fruit to some extent, including cherries.

The most effective remedy is to apply a poison spray-solution to the trees once just before the blossoms open, again just after the blossoms fall and about three weeks after that date.

The poison-solution may be made with three pounds of arsenate of lead and fifty gallons of water. To make the solution, mix the arsenate of lead thoroughly in a small quantity of water and strain into the spray-barrel. Add the remainder of the water, agitating the mixture thoroughly while it is being applied.

Paris green may be used for the poison in place of arsenate of lead, in the following proportion: Paris green, one-half pound; quicklime, one-half pound, and fifty gallons of water. Slake the lime in about a pint of water; sprinkle in the Paris green slowly; when the lime is all slaked and the whole is in the form of a paste, add more water and strain into the spray-barrel with the remainder of the water.

The arsenate-of-lead preparation is to be preferred to the Paris green, although somewhat more expensive. The arsenate of lead adheres better to the foliage and is more apt to be unadulterated. In applying the spray, care should be taken to wet the entire tree with the spray, but not sufficiently to cause the water to run off the foliage.

Where there are wild plum-trees or crab-apple trees in fence-corners or adjoining the cherry-trees, the curculio will be so abundant coming from these that there will be less chance of saving your fruit. It is, therefore, desirable to cut down all wild plum-trees, apple-trees, and the like.  
B. F. W. T.



This monogram on the radiator stands for all you can ask in a motor car

## You Can Now Buy the Famous Chalmers "30" Fully Equipped—\$1500

This 1912 car, at its new price, including full equipment and all the 1912 improvements, sets a new standard of motor car values.

Last year this car sold for \$1750, equipped with magneto, gas lamps, top and windshield. Think of it this year—refined and improved in every possible way, with thoroughly ventilated fore-door bodies, inside control, magneto, gas lamps, Prest-O-Lite tank, and including also Chalmers mohair top and automatic windshield—for \$1500!

Please remember that this is the sturdy car that was driven 208 miles a day for 100 days in succession; that made the trip from Denver to Mexico City; that has never been defeated in any sort of contest by a car of its own price and power; that holds the world's light car speed record; that won the hardest Glidden Tour ever held.

Remember that this car has given satisfactory service to 15,000 owners; that it is backed by an absolute guarantee for a year.

We really believe, whether you buy a Chalmers or not, it is worth your while to see the new cars.

We shall be very glad to send you our new catalog, and an introduction to our dealer nearest to you.

Chalmers Motor Company, Detroit, Mich.

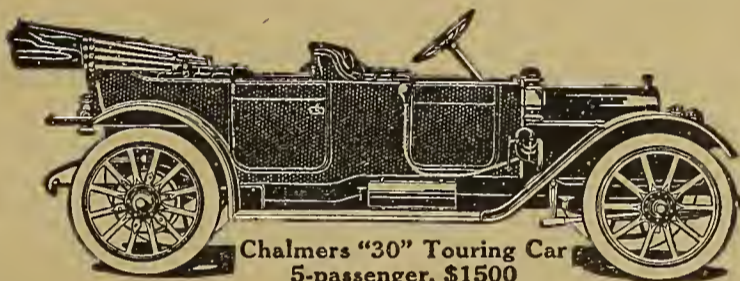

Chalmers "30" Touring Car 5-passenger, \$1500

Including magneto, gas and oil lamps, Prest-O-Lite tank, top, windshield, fore-doors, horn, tools. Made also as 4-passenger Torpedo, and Pony Torpedo and Torpedo Roadster.

### Fastest Hay Press 2 1/2 Tons Per Hour

Greater capacity is guaranteed in all Spencer Presses. The guarantee with our Alligator Press says "22 tons in 10 hours or no pay." Large feed capacity—smooth and compact bales, uniform in size. Load full weight into cars. All Spencer Presses are biggest money makers because they give greatest capacity at smallest operating and repair cost. Write today for free illustrated catalog L. L. describing full line.

J. A. SPENCER  
115 William St., Dwight, Ill.



### 15% More a Bushel

Throw away your spade. Digging Potatoes with a spade is out of date—wasteful—expensive. The Farquhar Diggers get enough more potatoes to pay back their cost—clean thoroughly. A Digger for every kind of soil. Send for book "How to add 15 cents a bushel to your Potato Crop" and catalogue of Farm Machinery. A. B. Farquhar Co., Ltd., Box 220, York, Pa.

**FARQUHAR**

## WET WEATHER COMFORT

Means the right kind of rubber boots—dependable boots—easy, good-fitting, long-wearing boots—in short,

### Woonsocket Elephant Head Rubber Boots

We have been making them for 45 years—as many as 10,000 pairs a day—in the only exclusive rubber boot mill in the United States.

All Dealers—Always Look for the Elephant Head Trade-Mark.

All our other boots and shoes also have the Elephant Head Trade-Mark.

**WOONSOCKET RUBBER COMPANY, Woonsocket R. I.**

Elephant Head Trade Mark

## BUY THE LOWEST COST ENGINE

MADE. Lowest fuel cost; lowest up-keep cost; easiest on the machine it operates, delivering steadier power than any other gasoline engine, adapting it especially for operating farm machinery, with better results and least waste of grain. Lowest fuel cost for it runs on Gasoline, Kerosene, Distillate, Gas or Alcohol and has perfect lubrication. Lowest cost because it delivers greatest available power per horse. A slow speed, high duty engine. Starts easier and quicker than any other engine, occupies less space, is less cumbersome, with less vibration, therefore adapting it for either stationary, portable or traction use. IT IS THE POWER CONTRACTOR'S FAVORITE ENGINE. No engine made has so wide a range of use. YOU WILL MAKE A MISTAKE IF YOU DO NOT WRITE US FOR INFORMATION. 1 1/2 H. P. to 5 1/2 H. P. single cylinder. 6 to 20 H. P. two cylinder. 30 to 50 H. P. four cylinder. State your requirements and get our advice. THE TEMPLE PUMP CO., Manufacturers, 492 West 15th St., Chicago, U. S. A. This is our 59th year.

## Free Roof Insurance Against Lightning

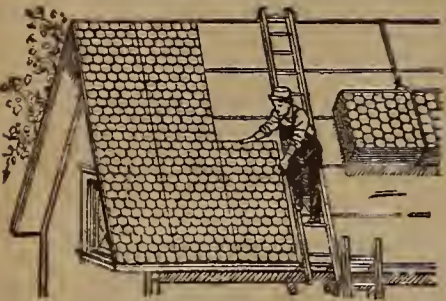

### Edwards Interlocking "Reo" Steel Shingles

Write today for our Big Free Catalog No. 768, which gives full details about Edwards Interlocking "Reo" Steel Shingles and other metal roofing and materials made by us. It tells you all about the Ten Thousand Dollar Guaranty Bond, which insures every Edwards "Reo" Steel Shingle Roof against destruction by lightning for all time.

Edwards "Reo" Steel Shingles are made of high-grade Bessemer Steel in sheets 5 to 12 feet long and 24 inches wide. Either painted or galvanized steel and all ready to put on. You can easily put them on yourself. Only hammer and nails required.

We have a Special Cash Money-Making Proposition for the man who writes for it, in each community. If any of your buildings need roofing, you are the man.

Send dimensions of your buildings and we will quote you cost of an Edwards Roof—freight prepaid. Write for offer—NOW.

The Edwards Mfg. Co., 708-758 Lock St., Cincinnati, O.  
Largest Manufacturers of Steel Roofing Material in the World (50)

**Ann Arbor**  
THE BAKER FOR BUSINESS

**Bales 73 tons in 10 hrs.**

**Better Value—Same Cost**  
Ann Arbor Balers are the cheapest, safest, and the greatest money earning and time saving hay presses built.

Bale easier, quicker, are safer and stronger; make better, tighter, cleaner bales. Cost less to run—last longer. Positively guaranteed. Twenty-five years' success building hay presses; our established reputation is your best assurance of satisfaction. Prices reasonable. Write at once for printed matter. Box 408  
ANN ARBOR MACWINE CO.,  
Ann Arbor, Mich.

# Genasco

the Trinidad-Lake-Asphalt Roofing

Find out why *natural* asphalt makes roofing that lasts years longer than artificial "asphalt" or coal-tar. Write for the Good Roof Guide Book and samples.

The Kant-leak Kleet waterproofs roof-seams and prevents nail leaks.

**The Barber Asphalt Paving Company**  
Largest producers of asphalt, and largest manufacturers of ready roofing in the world.

Philadelphia San Francisco Chicago  
New York

**BINDER** Attachment with Corn Harvester outfits and throws in piles on harvester or winnows. Man and horse cuts and shocks equal with a Corn Binder. Sold in every state. Price \$20 with Binder Attachment. S. C. MONTGOMERY, of Texaline, Texas, writes:—"The harvester has proven all you claim for it. With the assistance of one man cut and bound over 100 acres of Corn, Kafir Corn and Maize last year." Testimonials and catalog free, showing pictures of harvester. NEW PROCESS MFG. CO., SALINA, KAN.

## GET A FARM HOME NOW

We have farms for all, both great and small. In 21 States: from New York to North Dakota to Michigan to Missouri. For free list of fine farms ask B. E. McBurney & Co., 708 Fisher Building, Chicago, Illinois.

**Indiana Veterinary College**  
Graduates eligible for U. S. Bureau of Animal Industry, U. S. Army veterinarians and for private practice. Teaches every branch of veterinary science. Catalogue. F. A. MUELLER, Sec., 808 E. Market St., Indianapolis, Ind.

**LEARN JEWELERS' ENGRAVING**  
A high salaried and easily learned trade, taught thoroughly by mail. We will teach the beginner better engraving than he can gain in years of rigid apprenticeship. We will also improve the skill of any engraver. Send for our catalog. The Engraving School, 25 Page Bldg., Michigan Ave., Chicago, Ill.

**WHEELS, FREIGHT PAID, \$8.75**  
for 4 Buggy Wheels, Steel Tires. With Rubber Tires, \$18.45. Rubbing your wheels, \$10.30. 1 manufacture wheels 3/4 to 4 in. tread. Buggy Tops, \$6.50; Shafts, \$2.10. Learn how to buy direct. Catalog free. Repair wheels \$3.95. Wagon Umbrella FREE. F. F. BOOR, Clinton, O.

**PATENT** Secured or Fee Returned. Free Patent Book, Selling Guide, and List of Buyers and Manufacturers of Inventions. Advice Free. Send sketch. FARNHAM & SUES, Attys., 43 F. St., Washington, D. C.

**PATENTS** Send sketch or model for FREE SEARCH. Books, Advice, Searches and Big List of Inventions Wanted FREE. Watson E. Coleman, Patent Lawyer, Washington, D. C.

**LEARN TO WRITE ADVERTISEMENTS** EARN \$25 to \$100 A WEEK  
We can positively show you by mail HOW TO INCREASE YOUR SALARY. Book mailed free. Page-Davis, Dept. 25, Chicago Ill.

It is to your advantage to mention Farm and Fireside in writing to advertisers. Farm and Fireside folks get the very best attention.

**ONLY \$10. CASH**  
Balance \$5 a month, buys this three-year GUARANTEED Buggy. Write today for our FREE CATALOGUE of Buggies, Surreys, Spring and Farm Wagons. Century Mfg. Co., Dept. 619 East St. Louis, Ill.

# GARDENING

By T. GREINER

### For Late Cabbages

**W**HEN I have to set cabbage-plants late, the Early Winningstadt is usually the sort I choose. It is a pointed head, of fine texture and just the kind of cabbage that the home gardener will like to have on his table. Good heads may yet be made from good plants set late in July. If not Winningstadt, set Succession, or even Early Wakefield or Eureka. Whether profitable as a crop or not, we want nice cabbages late in the fall or during winter for the table. Old clover sod, well broken, and properly enriched with old stable manure, will usually produce good cabbages, early or late.

### We Want Ours Worm-Free

It is better to have a dozen cabbages free from worms than a hundred that are all riddled with worms, or slimy with slugs. If you have nothing better, try the hot soap-suds on wash-days, dashing them freely over the cabbage-heads. It will make short work of worms and slugs. The best thing for use in the home garden that I have yet found is buhach (insect-powder from California). Carry one of those little powder-guns loaded with buhach in your pocket when you walk through the garden, and puff the dust over and through the cabbage-heads. You will soon see the last of the worms. Buhach is so strong that it can be mixed with several times its bulk of flour, or lime or plaster, and yet do the business. It is not a poison.

### Clover Cleans Land

Many orchardists now use the ordinary clovers as cover crops for their orchards. Seed is sown after cultivation ceases in July. This practice adds humus to the soil, keeps it clean and enriches it in its nitrogen content. No treatment can be better for any garden-spot, old or new, than to put it in clover for a season or two. It seems to purify the soil most thoroughly, and fit it for almost any crop, even with lighter dressings of manure. The best way to use commercial fertilizers on garden crops is to feed the clover with it, make a big growth of clover, and feed your garden crops second hand with the clover and clover roots.

### A Remarkable Early Pea

I have never had green peas in this locality as early as this year. The Alaska has been our main dependence for first early these many years. It is a good-enough sort, and I am not yet ready to throw it aside. But for earliness the new Velocity is surely a wonder, and rightly named. We had the first mess the middle of June, and they were fairly good, although we had allowed them to get quite large in the pod. By the twentieth the vines were picked clean and the ground plowed up, ready for replanting with something else. I doubt whether this Velocity is as prolific as the Alaska, or the vines as thrifty, but most people appreciate earliness, and I, for my part, expect to plant the Velocity again next year.

### Bugs on Vines

A Pennsylvania reader wants me to give a good recipe for bugs on cucumber and other vines, something that will also be a good fertilizer. Anything that will push the vines into thrifty growth is, in a measure, also a help against the "bugs." On good land, land well manured with good old stable manure or compost, the vines will have a better chance against insect depredators than on thin, hard soil. It is the slow-growing or sickly vine which the "bugs" seem to like, not the healthy, well-fed plant. There is one combination, however, which is at the same time bad for the bugs and good for the vines—namely, a mixture, in almost any proportion, of tobacco-dust and bone-meal. Put this thickly around the hills, and plants in the hills, and it would not do any harm even if some of it covers the leaves. I have often used this combination with good results.

### Prizetakers Direct from Seed

A reader in Castile, New York, has planted a one-quarter-acre Prizetaker-onion patch, seed being sown May 5th, on good bottom-land. He is told that this is too late to make a crop, so he asks about planting the patch with late cabbages, although the onions have done well thus far, and there is a full stand.

I think his chances are good to raise a fair crop if the land is otherwise in good condition for growing a crop of onions. The bulbs may not grow as large as we can get them from early transplanted seedlings, but I have seen a big crop of large Prizetaker onions grown from seed sown in open ground early in May. At any rate, it would be unwise to tear up the onions to plant the patch with late cabbages. The onions, if

properly taken care of, will most likely give far better returns than the late cabbages could be expected to do.

### Pod-Spot of Beans

"Cause and prevention of rust on growing beans," is what a Washington reader inquires about.

The trouble is probably what is known as bean anthracnose, or pod-rust. Planting in dry and airy places, and avoiding rotation with cucumber and similar vines which are said to be subject to the attacks of the same fungus, are recommended. I would destroy all rust-affected plants, and save my own seed-beans from healthy pods. If there is no rust carried over on the seed, the bean-plants grown from it will most likely remain healthy.

### Wage War on Wireworms

The same Western reader complains of the work of wireworms on his potatoes, corn and beans, and asks if there is any practical method of destroying them. This surely cannot be done in a day, nor in a season. Wireworms are often very bad on potatoes, especially where planted in sod. No application to the land, except the plow at the right time, will be of any avail. Some have tried salt and lime, and sulphur, etc., but without satisfactory results. Sulphur is too expensive; other substances of no or little effect. But plowing late in fall, or, rather, just before the final freeze-up at the beginning of winter, or during an open spell in winter, will disturb the enemy in its hibernating stage, and break up its winter quarters, exposing the worms to the cold, or to be gobbled up by birds. A field thus treated repeatedly will soon be practically free from wireworms. The object is worthy of some efforts.

### Some Pie-Timber

A North Carolina reader asks me whether I have ever used the wonderberry for pies, and whether it can be used safely.

I have used them, as also the garden huckleberry (practically the same thing), and various kinds of husk tomatoes besides. All make good pies if rightly treated. The wonderberry and garden huckleberry, in the hands of a skilful cook, and with necessary lemon and other flavoring, can be transformed into pies that are hardly distinguishable from genuine huckleberry pies. Belonging to the nightshade family, the plants may be slightly toxic (poisonous), but I do not imagine that the danger of serious poisoning by eating a piece of this bogus "huckleberry" pie is very great. If I could gather the berries more easily, I would not hesitate to eat occasionally a piece of this pie. The plant, however, is a trailer, and the berries are usually very dirty from coming in close contact with the ground.

### Keep Weevil Off Beans

A reader asks how to grow beans free from weevils.

That is easy. Plant no beans that have live weevils in them. Do not keep beans anywhere on the place, in storage, that are breeding weevils. This insect can live from one year to the next and breed, even inside a bag of beans, and when the bag is opened, the full-fledged weevils will come out in a swarm, and go for fields anew. Whenever you gather beans that you suspect or know to have live weevils in them, put them into a tight vessel (barrel or the like), and set a saucer or other dish containing a tablespoonful or two of carbon sulphid on top of the beans, then cover the vessel tightly. Leave it thus for a day or two, and there will be no live weevil to start a new colony the next season.

### Small-Fruit Profits

Au Ohio reader wants to know the cost of setting out an acre, each, of strawberries, raspberries and blackberries, and what profits a person can figure on per acre above picking and other expenses.

The cost of planting an acre is more easily figured than the profits, although it varies much according to soil, prices of labor, plants, etc. For strawberries you want rich land, fairly free from noxious weeds. This must be plowed and fitted until smooth and clean. It may take half a day, or it may take the best part of two days, or more, according to the character of the land. You may not figure on more than three dollars per day for team-work, or it may cost five dollars, or even six dollars. It will require about six thousand plants to set an acre of strawberries. You may be able to dig them in spring from a patch of your own, at practically no extra expense; or you may have to buy them at three or four dollars per thousand, calling for an expenditure of about twenty dollars. In one day, if you know how, you can set them, with the help of a youngster, who carries and inserts the plants while you open the place for them with a spade or similar tool and press the soil back to the roots with the heel of your right foot. Here you have all the data, on the basis of which you can figure out for yourself what it will cost you to set an acre

of strawberry-plants. But when it comes to the profits, that is mere guesswork. It depends on the crop, on cost of picking, and especially on the prices you can obtain for the fruit. The profit may dwindle down to one hundred dollars or less per acre, and they may exceed five hundred dollars.

For raspberries and blackberries, less fertile and coarser soil will do. It should be well fitted, however, and the cost of plants and labor of setting them (about two thousand or less) will not be materially different from setting the acre of strawberries. The profits will likewise be liable to much variation, and ordinarily cannot be expected to reach near those from strawberries.

### Make the Potatoes Grow

In order to have abundant crops of potatoes, the suggestion I would offer, among others, is to use fertilizer a little more freely. It is not necessary to use the costliest ones, those containing a large percentage of nitrogen. For that element of plant-food the grower may well depend on his clover rotations. Most of these gravelly loams, that have been used for many years quite largely for the production of cereals, respond particularly freely to applications of superphosphates and to a considerable extent also to those of potash. A fertilizer, therefore, which contains eight or ten per cent. of phosphoric acid and four to eight of potash, costing, say, eighteen or twenty dollars per ton, should in most cases largely increase the yield of potatoes, as well as other crops, if applied at the rate of about five hundred pounds per acre.

In the earlier times we used to run through the rows with our clumsy cultivators twice during the season, in both directions, and then had to make free use of the hand-hoe. The potato-grower has learned something since, and uses his improved implements of tillage more, and the hand-hoe less. He kills a good share of the weeds in the land before the potatoes are planted and is through with his work of tillage when he has done the last killing with the improved killing device. Potato-growing here, in the old days, used to be drudgery from the very beginning to the end—the end being the final delivery to buyers at the stations and pocketing the proceeds for reward. Now potato-growing has been raised to the level of a business enterprise.

With simplified methods of production, a better understanding of the problems of fertility maintenance, better roads and improved marketing facilities generally, the potato crop is proving even more satisfactory than in the earlier times. I don't see that the potato-growers are getting rich very fast, but they are not going to the poorhouse, either. Well managed, the crop leads to independence and pays off the mortgages. This in spite of the multiplications of the enemies of the crop.

The most serious of the insect pests of the potato in these regions, I believe, is the flea beetle, several species of which are regularly infesting and injuring the plants by perforating the leaves and opening the way for the attacks of tip-burn and blights. Most of the potato-growers still use Paris green, either alone or in Bordeaux mixture, as a remedy for the "potato-bug." If they would use arsenate of lead in place of it, in strong doses, say, at least two and, better, three pounds to fifty gallons of either Bordeaux mixture or lime-sulphur solution diluted one to forty, the flea beetles, together with the potato-beetles and slugs, would cease troubling the plants, and blights would have less chance.

Varieties come and varieties go. It is very seldom that we find a variety like the Early Ohio, which is still a leader among the earliest in some of our potato districts, after having been in cultivation for forty years. Most varieties go up like a rocket and come down and go out shortly after. The Burbank, the White Star and others had a few years of deserved popularity and were then lost sight of. A lot of new ones, too numerous to mention, have appeared on the scene, and the change of varieties is going on right along. Early sorts are hardly grown in this great potato section to a greater extent than for home use. This branch of the business is left to market gardeners and growers near the cities and big villages. It could be made a paying business, too. Growing potatoes for late fall, winter and spring market means, of course, late varieties and good storage facilities. The old methods of wintering potatoes in big, conical heaps outdoors, covered with straw, soil and manure, as we used to practise it here in the old days, has gone out of fashion. Wintering in potato-cellars has been found a more convenient and safer way.

### "Black Bugs" on Asters

**A**LADY reader from North Carolina states that "black bugs" eat up her asters. She does not send a specimen, and we cannot be sure of the insect from the description. One aster pest is the white aphid, which is preyed upon by black and red ants, but it is the aphid that does the damage. People sometimes blame the ants. Better send specimens of the insect to the entomologist at the North Carolina Experiment Station, with plants on which they have worked. And look for aphids.

B. F. W. T.

# Farm Notes

## The Greatest Enemy of the Honey-Bee

THE enemy that threatens the destruction of the bee-keeping industry in the United States is a germ disease known as foul brood. It exists in every part of this country to a greater or less extent and, according to the testimony of experts, is on the increase. There are two varieties of the disease, but the difference can be detected only by experts.

As the name indicates, it is a disease of the brood. Healthy brood is of a glossy whiteness in appearance. When foul brood first appears, its presence can be detected by a change in the color of the brood from white to a light brown, in the infected parts. In the early stages of the disease the larvæ usually die after the cells are sealed.

The ordinary observer will not be able to detect the presence of the disease by the color of the brood. Many hundreds of the young bees will die in their cells before the truth is known. The plainest indication of the disease is the sunken and perforated cappings of the cells in which the young bees have died.

The color of the dead matter in the cells is a dark brown and the odor is the same as that of any putrefying animal matter. The simplest test is to insert a small stick, as an ordinary toothpick, into the putrid mass and draw it slowly out. If the matter clings to the stick and the cells, so that it is drawn out in aropy string an inch or two in length, it may be considered a conclusive test for foul brood.

### Free Test Can Be Made

The Agricultural Department at Washington has made provision for testing diseased brood. After the above test has been made, or even if one suspects that the brood is not healthy, a sample of the infected comb, not less than one inch square, should be cut out and mailed in a tin or cardboard box to Mr. E. F. Phillips, Ph. D., Bureau of Entomology, Washington, D. C. This sample will be subjected to a bacteriological examination, and a full report will be forwarded to the sender, free of charge, in a few days.

It may seem to some that this is a subject of interest to experts only, and that the ordinary bee-keeper need not trouble himself about the matter. This is a very serious mistake. The experts and the inspectors in the states where foul-brood laws are in force cannot cope with the disease without the cooperation of the owners of the bees. The only hope, for the present, is for every intelligent bee-keeper to inform himself as to the symptoms and the cure of the disease, that he may take measures to stamp it out when it first appears.

### What is the Cure?

The cure of foul brood is not a difficult operation when it is taken in time and the right methods are used. If it is allowed to run until the combs are festering masses of dead brood, and the colonies are weakened on account of the loss of brood and bees, the case is hopeless. There is not a better nor a safer method to follow in such a case than to burn the hive and all it contains. And even so it should be burned in a furnace, so that not a particle of honey or wax shall remain to carry the infection to healthy colonies.

Fumigation and disinfection have not proved effective agents in either curing or checking the progress of foul brood. The method of treatment that has been most successful is one by which the bees are forced to build new combs after they have been deprived of the old infected combs. The treatment is based on the theory that if the bees have an opportunity to use up all the infected honey in comb-building, with no brood present in the hive to harbor the disease, it will not appear again in the new combs.

The best time to employ this method of treatment is during a honey-flow. The infected hive is removed from the stand and a new hive, containing frames fitted with foundation starters, is put in its place. The bees are shaken into the new hive, and the frames containing the diseased brood and the infected honey are destroyed. The hive may be saved if it is carefully burned out on the inside. After four days the bees are again shaken into a hive with frames fitted with full sheets of foundation, where they are allowed to remain. When brood-rearing begins in the new combs, the disease will have disappeared. ROBERT B. MCCAIN.

Don't sell everything on the farm, and do without yourself. Have plenty yourself, too.

When in town some day, ask your merchant the price of honey; then consider that a single stand of bees will produce one hundred pounds of honey every season, and you surely will secure a few stands of bees as a "side-line" to your other farming.

## Curing Cow-Peas

PERHAPS one of the most difficult things for most farmers to do is to cure cow-peas correctly, for, when the process is not understood, it is no easy task. I suppose that stock receives moldy cow-peas more than they do all other moldy foods combined, yet, when understood, cow-peas are no more difficult to handle than clover. I have handled this crop for ten years. People have told me that their cow-peas were in the finest cure, but when desired for feed, the hay was full of blue mold. I told them that I didn't wonder at it. I have done the same thing and have seen others do it, and have come to the conclusion that you cannot dry cow-peas dry enough to mow away without first putting them through a sweat; in fact, I know you cannot. If you will handle your peas correctly, you can cut them quite green. Cut them down and let them lay until they look cured on top. Then, if you have a tedder, stir them up with that, but if you have not, just rake them up in windrows and then cock them up in old-fashioned cocks good and large and high. When they get hot, tear them to pieces and let them cool and dry. When you feed them out, after this process, you will not be strangled with blue mold.

Last year I had about two tons of cow-peas and a grass common around here. I thought I would run the risk of letting it dry a week, and then put it in the mow, without first cocking it. In about three days I went to see how it was coming on. I had to throw it all out of the mow. It was so wet I could almost ring water from it.

SHERMAN SLOTER.

EDITOR'S NOTE—This statement comes as a word of caution to those who are expecting to grow cow-peas. Canvas hay-caps are most desirable additions to the farm supplies on any farm where cow-peas are raised. FARM AND FIRESIDE has published several suggestions as to the manufacture and use of caps for hay and grain.

## Canvas Hay-Caps Water-Proof

A VIRGINIA subscriber asks how to make canvas water-proof.

A formula which is used with success and which is especially suitable for water-proofing hay-caps is as follows: Old, pale linseed-oil, three pints; sugar of lead (acetate of lead), one ounce; white resin, four ounces.

Grind the sugar of lead with a little of the oil, then add the rest with the resin. Use an iron kettle over a slow fire, apply with a brush while hot. B. F. W. T.

## Disk Your Land Now

ONE of the best-paying things any farmer can do this season is to run over grainland with the disk as soon as the grain is cut off. This will help in a number of ways.

If the ground is to be plowed in the fall, it will be in better condition and will take less horse-power. It will hold the moisture that is left in the ground, and when any rain does happen to come, it will catch all of it.

All land should be disked before it is plowed anyway, for this process makes the soil-bed deeper and more agreeable for root-growth. The sooner this is done after taking off the crop, the less moisture will be lost, and the better the ground will be to work.

In riding through a farm district, it is easy to see, now, which ground was best prepared. It shows up in the crop. Cloddy fields with little preparation don't stand any show by the side of well-prepared fields. They lose moisture too fast. A. C. PAGE.



## The Latest Agricultural Reading



**The Practical Country Gentleman**, by E. K. Parkinson, contains information for the owners of country estates, large or small. It discusses water-supply, pumps, crops, fertilizers and farm buildings, and shows how the farm home may be made both beautiful and profitable. Pages, 184; illustrated; price, \$1.25; A. C. McClurg & Co., Chicago, Illinois.

**Farm Dairying**, by Laura Rose, contains many useful suggestions conducive to success in dairying. It takes up all sides of dairy-farm management, gives symptoms and treatment of diseases common to cows and rules for making foreign types of cheese and fancy dairy products. Pages, 298; illustrated; price, \$1.25; A. C. McClurg & Co., Chicago, Illinois.

**The Report of the Commission on Country Life**, which Congress refused to have printed for general distribution, is at last available in full, having been published in book form by Sturgis and Walton, 31 East 27th Street, New York City. Pages, 150; price, 75 cents.

# SWAP STUMPS FOR DOLLARS

### CLEAR WASTE LAND WITH



## RED CROSS DYNAMITE



Drawn from actual photograph

Stumps blasted out into firewood



Same field ten months later—\$800.00 worth of celery per acre

To learn how progressive farmers are using dynamite for removing stumps and boulders, planting and cultivating fruit trees, regenerating barren soil, ditching, draining, excavating and road-making, write now for Free Booklet—"Farming With Dynamite, No. 90"

## E. I. DU PONT DE NEMOURS POWDER CO.

PIONEER POWDER MAKERS OF AMERICA

ESTABLISHED 1802

WILMINGTON, DEL., U. S. A.

Store-keepers wanted in every town and village to take and forward orders for blasting supplies. Not necessary to carry stock. Large sale possibilities. Write at once for our Dealer's Proposition. DUPONT POWDER CO., DEPT. 90, WILMINGTON, DEL.

## This Thrifty BLIZZARD Ensilage Cutter Makes Short Work

Send for New Catalog of any feed and our improved wind elevator carries any height or direction. Every BLIZZARD cutter is tested by 50% harder strain than is ever called for in ordinary use. That's why we can and do guarantee them.



The Guaranteed Cutter. Why take Chances on Unknown Makes.

Used for 38 Years and Proved Most Practical. Easiest running, strongest. Only cutter with knives adjustable while running at top speed. Self feed table. Mounted or unmounted. Shipped ready to put up. Nothing complicated. Ask for free book, "Why Silage Pays." JOS. DICK MFG. CO. 1444 W. Tuscarawas St., Canton, Ohio

## New Wheels for the Old Wagon

Let us fit your old wagon with "Electric" steel wheels and make it strong and good as new. Another wagon life and a real handy wagon just by buying wheels. Broad tires, never any resetting, no drying apart, rattling or coming loose. Free book gives particulars and shows how it pays big to fit up old wagons with the long-life Electric Steel Wheels. Write for copy. ELECTRIC WHEEL CO., BOX 13, QUINCY, ILL.

### Electric

## EMPIRE FENCE

Get the genuine EMPIRE big wire fence, direct, at wholesale. Save dealer's profits.

### Big Factory, Big Sales, 23 Styles

No traveling salesmen, small expense, prices low. Everything guaranteed. Free samples by mail. Prices of leading styles freight prepaid to all points north of the Ohio and east of the Mississippi River:—

Wires	Inches high	Medium Weight	Extra heavy (all No. 9)
9	39	23c per rod	37c per rod
10	47	23c per rod	41c per rod
12	55	32c per rod	49c per rod

Special rates beyond this territory. BOND STEEL POST CO., 42 E. Maumee St., Adrian, Mich.

## More Rye

Rye serves the double purpose of a cover crop or a grain crop. In either case it pays to use the right kind of fertilizer on it—the kind that contains enough Potash to balance the phosphate. The mixtures we have told you to use on wheat are suitable for rye, but the

# POTASH

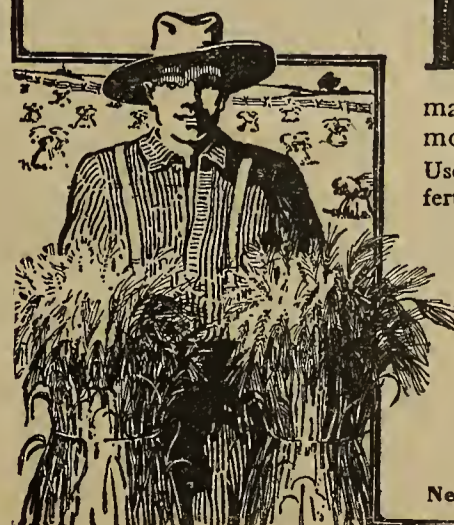

may be even higher, since rye uses more Potash than wheat does.

Use from 300 to 400 pounds per acre of a fertilizer containing 6 to 8 per cent. of potash.

If your dealer does not carry potash salts, write us for prices stating amount wanted, and ask for free books on *Fall Fertilizers* and *Home Mixing*. They will show you how to save money and increase profits in your fertilizer purchases. **Potash Pays.**

## GERMAN KALI WORKS, Inc.

Baltimore: Continental Bldg.  
Chicago: Moundcock Block  
New Orleans: Whitney Central Bank Bldg.

### Theres No Profit In keeping A lame Horse

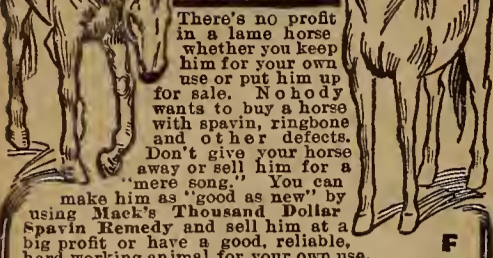

There's no profit in a lame horse whether you keep him for your own use or put him up for sale. Nobody wants to buy a horse with spavin, ringbone and other defects. Don't give your horse away or sell him for a "mere song". You can make him as "good as new" by using Mack's Thousand Dollar Spavin Remedy and sell him at a big profit or have a good, reliable, hard working animal for your own use.

Mack's Thousand Dollar Spavin Remedy will quickly and permanently relieve the very worst case of bone and bog spavin, Ringbone, Thoroghipin, Curb, Splint, Capped Hock, Shoe Boil, Sprung Knee, Lacerated and Ruptured Tendons, Sweeney and all other forms of lameness affecting a horse. It's a powerful Remedy that goes right to the bottom of the trouble and quickly restores natural conditions in the bones, muscles and tendons—cures the lameness in just a few days to stay cured and the animal may be worked as usual. Cures hundreds of cases formerly considered incurable.

Contains nothing that can injure the horse and heals without leaving scar, blemish or loss of hair. We positively guarantee every bottle of Mack's Thousand Dollar Spavin Remedy; if it fails, you get back every cent you pay for it as stated in our

**\$1000 Warranty Bond.**

For sale by Druggists and Dealers everywhere, or by prepaid express direct, upon receipt of price, \$5. Get a bottle today. Cure the lame horses you now have and be prepared for emergencies.

**Veterinary Advice FREE**

If you are not sure you have made a correct diagnosis of your animal's lameness, write us a letter telling all the symptoms, and our Veterinary will tell you just what the trouble is and how to cure it. Don't hesitate to write whether you have ever used Mack's Spavin Remedy or not. This advice is free to all.

BOOK "Horse Sense" and sample of \$1,000 Warranty Bond mailed free upon request.

Distributed by  
**McKallor Drug Co., Binghamton, N. Y.**

### Farm Notes

#### Protect the Bumblebee

FROM earliest years it has been the policy of farmers to destroy the nests of bumblebees. Burning the nests after each hay season was a favorite pursuit after dark.

Then the advent of the heavy-heeled patent mowing-machine, that ground and crushed nests and young alike, helped to kill off the big, banded bumblebee. The skunks dug out and devoured every nest they could find, and the bees became so few that the clover crops grew short. It was hard to get a set to seed, and the farmers didn't know why. At last they found out that there were no little fuzzy bumblebees to carry the pollen from blossom to blossom; and no big, booming-voiced ones to help it along. Read this clipping from the *Kansas Farmer*, of late issue:

At the Kansas Experiment Station a small plot of vigorous alfalfa was covered just before coming up into bloom with mosquito-netting supported on sticks. It was therefore known that no bees or other insects would come into contact with the blossoms. Later, a careful examination disclosed that the pods which had formed were entirely without seeds.

Soil, season and seedsmen have been blamed for the failure of crops whereas it has frequently been the fault of the farmer himself, and his boys, in killing the bumblebees. Why, I'd take a sting or two, and let the bees live, rather than kill one. Have done it, too. And when one blunders into the house, I raise the window and let him out, for there are too few of him.

In mowing, let one man go ahead of the machine with a cane and spy out the nests, mark the spot and cut around it. If I knew of any way to protect them in winter, I'd do it. There should be a legal protection for them, for the sake of fruit, clover and blossom.

Weeds in the fence-rows and odd places about the farm will grow just as many seeds as any others. Clear them out.

### Make Your Own Rope

THIS is a rope-machine we have used and it has proven very satisfactory. First, get a two-by-four, six feet long (A). Set it firmly into the ground two feet. Next, bore a hole, three-eighths inches in diameter, six inches from the top of post. Then another six inches below the first. These holes should be bored from the flat side. Mark a line through the holes and rip far enough down so that it will spread and admit a three-eighths-inch rod.

Get a three-eighths-inch rod, cut two rods each fourteen inches long (B). Bend a hook an inch in diameter on one end. On the other end, eight inches from the end, make a square turn. Then four inches from the end bend so as to form a crank (B).

Get a three-eighths-inch rod. Cut one rod sixteen inches long for the center crank (D). Bend same as other cranks, only have six inches for handle. Insert cranks in the holes of the post (A) by sliding them down the ripped places. Fasten in place by bolts

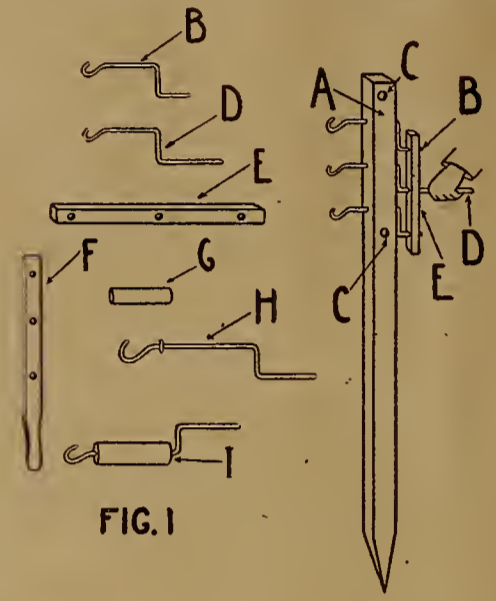

to hold cranks in place. Next get a two-by-two-inch piece, sixteen inches long. Bore three three-eighths-inch holes, six inches apart, to connect the cranks so that, when you turn the center crank, all will turn (E). Fig. 1 shows machine put together, side view. Fig. 1 also includes a display of the various parts. Get a one-by-two board eighteen inches long (F), bore three one-inch holes six inches apart; shape lower part of board like a handle. Now get a wood or iron pipe six inches long with one-half-inch hole in it, and a three-eighths-inch rod (H) eighteen inches long. Bend a crank somewhat like the crank B. Run through pipe G and bend hook. I shows the thing completed.

Now, to make rope it needs three men. Step off the length of rope you wish, then allow one fourth for shrinkage. Let man or boy get in his position to hold I. Get good, strong binding-twine and thread machine. Put any number of strings you wish in each

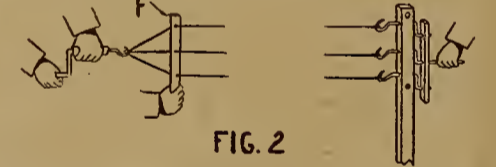

strand. Each strand fastens on a hook on the crank. Be sure to run each strand through the holes in board E. Now you are ready to commence, as in Fig. 2. Eighteen twines make a three-eighths-inch rope, and so on. One ball (five pounds) makes 145 feet of good, strong three-eighths-inch rope. This rope is cheaper and better than that ordinarily purchased, if you get on to making it right. Rods used in cranks may be of any convenient size. Roy IRISH—G. E. OLSON.

### For Better Pastures

THE farmers of this country might keep thousands of head more cattle if their pastures were in better condition.

The care given to the pasture-lands is not at all creditable. The most cursory investigation of the subject by any fair-minded man will show that by far the greater part of our pastures are rough, weed-infested and grown up to stuff that cattle cannot eat. There are hundreds of acres of such land all over the country. Add to this the fact that what grass does grow is often coarse and lacking in nutritive qualities, and it may be seen how such a condition must curtail the number of cows, sheep or other stock kept by our farmers.

I never had my attention called to this more forcibly than when, a few years ago, we set out on our own farm to clear up the pastures. Through a long series of years these lands had been permitted to grow up to everything except good pasture-grass. Elderberry-brush, with stalks as big around as a man's ankle; blackberry-bushes, red-raspberry canes and weeds of every name and description grew rank all over some of the fields. To add to the difficulty of the situation, there was an old slashing of a number of acres on which logs and stumps lay thick, while in still another place saplings

grey thick and tall. The cattle used to lie around under these trees and fight flies; but as for getting anything that would make flesh or milk, there was very little.

But we had lots of ambition, and not knowing what it would mean to tackle such a job, we began.

First, we cut off the elderberry-bushes. That was a hard job, but it was fun compared with what followed. Then we put the best team of horses available, and a rugged man between the handles, to plowing the field. That was business, and no mistake. It was hard work for man and beast. The plow had to be pulled back a thousand times a day. Every ounce of strength had to be put on the beam of the plow to hold it in the ground. It cost me eight dollars to plow one little piece of land of about an acre and a half; and then it seemed as if we had only begun.

If any progress is made toward really rooting elderberry out, it must be thorough, or the work will have to be done all over again.

So we went at the task of getting all those roots out of the earth. With one horse and a stone-boat, we began. We began, and we finished, but only when we had two great heaps of roots, and backs as lame as ever in all the world. When the roots were dry, they were burned, and that was the end of them.

But how that work did pay! First we had a crop of buckwheat there, which is a good crop to kill any weeds that may appear. Then we followed with corn and potatoes. What a crop we had, too! I never had finer corn anywhere than we had right on that land which a little while ago was so infested with foul stuff. Then oats followed, and grass-seed. That has been a fine piece of pasture-land ever since.

Encouraged by this, we ventured on the slashing and the part of the field which had been permitted to grow up to saplings. The logs were cut, piled and burned; such of the stumps as could be taken out we drew and burned. It was hard work, but healthy. The smell of the burning wood gave us appetites like tramps.

From the field above, which had been grown up to small trees, we cut wood enough to last several winters, while the brush was all piled and the briars nicely cut off. Taking the work in the fall of the year after haying, few sprouts grew up from the trees cut down. A splendid quality of timothy and white clover made that part of the pasture the favorite camping-place for the stock. The sheep particularly liked to feed there, it being high land.

Then we cut the pastures all over in the fall after that and got them into the best shape that they ever were. The best part of it was that we had learned what we could do. The added ground enabled us to keep more cows, and keep them better.

Now, this is what every farmer might do. We have not spoken of this in any boasting way, but simply to show what it would mean if all farmers were to set about it to make their pastures better.

E. L. VINCENT.

Mrs. H. H. Hawley, Oregon, wrote us recently about FARM AND FIRESIDE: "I read it, but he (her husband) studies it, thinks it and farms by it; files it away for future reference, as it is, in fact, his textbook."

Are you doing the same? If not, you are missing the real purpose for which the editors are sitting up nights planning, working, thinking. If they are not making every issue worth to you many times the cost of a whole year's subscription, they are sorely disappointed, because they feel that you are not making the most of your opportunity.

Farm papers have a mission to perform—that mission is to aid you to become better farmers, better home-builders, better husbands and wives, better citizens.

### Fortune-Telling Post-Cards

With these cards you can have loads of fun telling the fortunes of your friends. Tell them their lucky and unlucky months and days. You can tell them more about their characteristics than they know themselves. Send us three two-cent stamps, and in return we will send you, post-paid, a complete set of these new Fortune-Telling Cards.

FARM AND FIRESIDE, Springfield, Ohio

### Little Engine—Heap Big Help on Scorching Hot Summer Days

Right now, when Old Sol is working overtime and farmers are kept on the jump taking care of the crops, **pumping water** for a bunch of thirsty stock becomes a frightful task. That's when the little Farm Pump Engine comes to the front and proves itself a **life-saver**.

**Pumps 400 to 1,500 Gallons of Water Per Hour!**

Worth many times its cost for **hot weather pumping alone**. Works right through the year, in heat or cold, indoors or out. Never waits for wind. Costs almost nothing to run it.

### Fuller & Johnson Farm Pump Engine

**"Fits Any Pump and Makes It Hump!"**

It's a complete and perfect Power Pumping Plant. Needs no belts, arms, jacks, anchor posts or special platform. In 15 minutes after you take it from the crate you can have it attached and pumping to beat the band. Air-cooled, self-oiling. Starts instantly. Gives fire protection. Waters lawns and gardens.

**Runs Separator, Churn, Washer, Etc.**

Helps the man, the wife, the boys and the hired man do all kinds of chores. Anybody can run it. Every engine **guaranteed**.

**Get a Farm Pump Engine NOW—You Need It!**

Write for Free Engine Book and name of nearest dealer who has this marvelous engine on exhibition. Don't delay, for the rush of orders threatens to exhaust the supply. Write today. (302) applied for.

**Fuller & Johnson Mfg. Co. (Est. 1840) 7 Forrand St., Madison, Wis.**

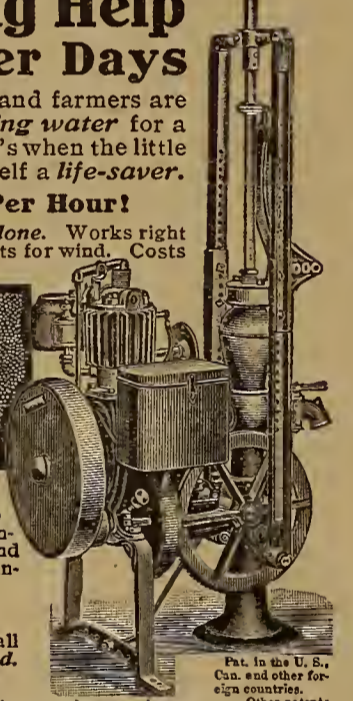

### THE DAIN BELT POWER HAY PRESS Means Bigger Profits With Less Work

Here is the strongest built, biggest capacity hay press in the world. Biggest capacity means greatest earning power. It's the extra tons each day that count—the kind of profit that is all velvet.

Earning power and low operating expense make the Dain Belt Power the most profitable press to operate.

Don't be satisfied with mere claims for capacity—learn the reason why. One reason for Dain big capacity is one-third more space into which hay can be fed. It's on account of the patented condenser hopper which opens up to receive the hay, giving 12,000 cubic inches more space. Then it automatically condenses all the hay in the hopper, after which the self-feed puts it into the pressing chamber.

**Dain Condenser Hopper** is the greatest improvement ever put on a hay press to lessen the work of feeding and increasing the capacity.

No stronger, more durable hay press ever built—the Dain is as staunch and strong as though moulded into one piece of solid metal. Built entirely of steel, it has not a single part that will shrink, swell or warp out of shape.

Twin pitman gears and direct drive pitman supply tremendous pressing pressure. Convenient block dropper—saves time and accidents.

Friction clutch pulley and stop brake insure easy and perfect control.

**Like All Dain Hay Tools** it is as nearly perfect as it is possible to build. Every little detail that years of experience have shown is desirable has been thoughtfully supplied in this master hay press.

Write for our big hay press catalog giving complete information about the Dain line of Belt Power and Horse Power Presses.

**DAIN MANUFACTURING COMPANY**  
No. 860 Vine Street, OTTUMWA, IOWA.

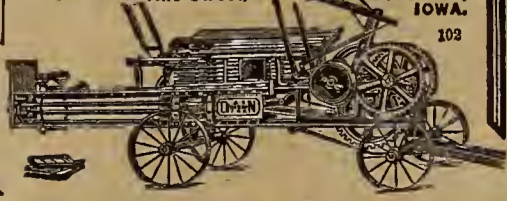

**LIGHTNING HAY PRESSES**

Tested for over 25 years. Made in many styles, Horse Power, Belt Power and Self-feed Attachment. Simple and Durable with Greatest Capacity. They make a Profitable Investment.

We can suit you. Write for Catalog and Prices.

**KANSAS CITY HAY PRESS CO. 124 Mill St., Kansas City, Mo.**







# The FARMERS' LOBBY.

**W**E SHALL get parcels-post legislation from this Congress if we all pull for it. That is the opinion of the post-office committees of both houses, and of the men who have been working for years to secure it. It will not come this session, but it will before March 4, 1913.

The house committee has been holding hearings on parcels post, and its advocates gave without question the strongest presentation ever made for it. They indicated for the first time, so far as I have observed, a capacity to meet every argument that has been urged against it, and to press some new and very strong ones.

Two men whom I heard address the committee stated, between them, what seemed a complete and unanswerable case for parcels post. One was Herbert Quick, editor of *FARM AND FIRESIDE*, who made the best speech I ever heard on the subject. He is a modest man who might feel a delicacy about admitting so much in his own columns; but I insist on admitting it for him. He fitted his argument for parcels post into the great national cost-of-living question in a way that made it peculiarly effective.

Mr. Quick told why parcels post would make living cheaper for town and city, and at the same time improve business for both. His argument provides for two of the four classes of people concerned about this issue. Mr. Geo. P. Hampton took care of the third—the village people—by showing how parcels post would help them. There is left the fourth class, which I don't think will be convinced, or needs to be: the express interests.

One would assume that if farmers, city folks and village folks were united for a proposition, and nobody but the express companies against it, its victory should be easy. It should; but the fact is, that for twenty years the express companies have won by fooling the people in the other classes. The time for that sort of buncombe is about ended.

## The Farmer Looks to Congress

**F**IRST, about cost of living. Mr. Quick declared that the farmer is entitled to be brought into touch with the commercial centers, through quick, regular and moderate-priced transportation. "Under present conditions, and in view of postal developments in other countries," he said, "the farmer has a right to that; and he knows he has, and he looks to this Congress for relief.

"From this service he would get this benefit: In the first place, he would have intimate business relations with his own village. If he broke a machine, he could send for repairs. If he had also access, by parcels post to the nearest warehouse for distribution of agricultural machinery, he could wire for the part needed, and receive it next day by mail.

"More than this, he could prepare hampers of produce each week for the hamper trade which is being developed in various parts of the country. A hamper is a container, commonly of wickerwork, with compartments. Filled with fresh vegetables, butter, eggs, fruit, etc., it could be forwarded to his city or town customer by parcels post. The farm would thus be brought to the city man's door.

"This trade is successfully carried on where the express facilities and rates permit. In Europe, it is becoming a highly important industry. In the newspapers of London, Manchester and Glasgow you will constantly read advertisements of truck-raisers who supply the 'hamper trade' in this very way. It is bringing the farmer and the city consumer into direct touch. There is nobody between them but the transportation furnished by the government at the lowest possible figure."

## American Situation Peculiar

**M**R. QUICK pointed out how much such a system had done to keep living costs within bounds in other countries. He expressed the opinion that the complaint of city-dwellers in this regard is more universal and better justified in America than in any other country, and boldly attributed the bad conditions here to the fact that while other and more progressive nations have provided their people with cheap and efficient means for bringing food to the city, this country has been sadly remiss in this regard, with the result that no farmer can engage in this business unless he has an express office near his door. If he is back from the railroad, the cost of sending to the station is too great; he loses his market, the town man loses the benefit of the direct communication. The commission man, the wholesaler, the marketman,

## American Parcels Post

By Judson C. Welliver

the small retailer, the expensive delivery systems that are employed in cities—all these come in to supply the link which is left unforger because there is no parcels post.

"Has it been your observation," inquired Congressman Weeks, "that what you describe has been effected by the rural delivery service?"

"That service has helped greatly, but the rural delivery applies only to dissemination of intelligence," replied Mr. Quick. "That is important; but man cannot live by opinions alone, any more than he can live by bread alone.

## What About the Cost?

**W**HY, you have these thousands of postage wagons going out empty. I have watched them in every town—traveling the length and breadth of the country—and it is a constant marvel to me that our great Post-Office Department and the Congress which governs it would consent longer to the tremendous waste involved in the system."

Members of the committee undertook to interpose that Mr. Quick's plan would require more men and horses, and would impose a big additional expense on the department. Mr. Quick retorted with some statistics about the length of routes covered by cream-haulers in the dairying states, and the weight of their loads and cost of service. A good cream-hauler used to cover twenty-five miles a day out in Iowa, and bring in a heavy load at night, with two horses and a wagon, he declared.

"And," he added, "I believe the suggestion that motor vehicles might be used on these roads is well worthy of consideration. We are told that not more than a third of the roads are fit for motor service. Well, there is a similar situation in towns where the department refuses to deliver mail in sections where the walks are bad. I believe the adoption of motor cars for parcels post where the roads are good would give the greatest impetus to good roads. Sections with bad roads would have to get along with deliveries by horse.

"It would be futile to deny that parcels post would add somewhat to the cost of delivering the mails. Yet I understand the fourth assistant postmaster-general and other experts, who have given some time to study of the Sulzer bill, have declared that in the end it would not only cost the government nothing, but would actually add \$35,000,000 a year to post-office revenue."

"What would be the effect of parcels post on the small town?" asked Chairman Lloyd.

## Express Companies are Interested

**T**HE general parcels post does not seem to have hurt the small town of Europe. Furthermore, I understand there are practically no mail-order houses in Europe. I understand the largest mail-order house in this country is opposed to the parcels post. They would have to pay postage in advance, but that is not the real reason. They already have terms made with the express companies; their tremendous distribution of freight is organized in a way that is one of the wonders of the mercantile world, and they are quite satisfied with things as they are. They now distribute most of their catalogues by express. What their relations to freight rates may be, I do not know; I can only surmise. But I do know that two or three houses have a practical monopoly of the mail-order business, and if the parcels post were established, the village merchant, and everybody else, would be on equal terms with them. If I owned a great mail-order concern, and my attitude were merely dictated by selfish considerations, I should oppose parcels post."

"Do you think the small merchant receives much of his merchandise in small packages?" asked Mr. Weeks. "Does not most of it come by freight?"

"I think that is true," replied Mr. Quick. "But he can send out a great deal in small packages by parcels post. A friend of mine in Germany last summer found some table linen that she fancied. 'Send a dozen of these to my hotel,' she said. The clerk replied, 'We regret not to have these cloths in that size; but if you will give us your hotel address, we will send them by parcels post, and they will be delivered to-morrow morn-

ing.' They were so delivered, but they came from another city: the Munich merchant had ordered them sent direct to the hotel. He got his commission; made more out of the transaction than if he had had the cloths on his shelves. Now, the business of that kind would be in the hands of the country merchants all over the land, to a greater degree than any of us can realize, if we had a parcels post."

Mr. Quick said he did not believe parcels post needed a local trial somewhere, but he was willing to have the zone system adopted, allowing parcels delivery between all offices and persons within a given radius; the Sulzer bill has proposed fifty miles. He preferred one hundred. That plan would bring everybody within parcels-delivery distance of everybody else inside the zone. Each commercial center would have a chance to exchange parcels with all the farmers within its radius; and the farmers could do business with everybody else within the fixed distance.

Mr. Quick's presentation of the advantages to the country-town merchant was elaborated by George P. Hampton. Mr. Hampton has long studied the question of the parcels post and the country town.

He declares vigorously that the country town is not going to be killed by parcels post; it is being killed just as fast as possible by the need of the parcels post, and by other transportation conditions that give the terminal cities all the business opportunities.

"The new census," he said, "will prove that the small towns have been gaining little, or actually losing, in population. The cities are gaining. Why is it? Because the transportation facilities are adjusted to the purpose of developing business and concentrating it in the cities. The intermediate places do not get it, and the plan does not contemplate giving it to them.

## The Village Needs Parcels Post

**T**AKE the business of manufacturing. I have known many cases in which concerns desired to establish factories in small towns, in preference to large cities. The reasons are obvious. Better living conditions are possible for the people; the same wage will go farther in a small town than in a city. Moral conditions are better. There is less danger of labor troubles in small than in large centers. Land is cheaper; it is often much easier to secure sidings, etc.

"In short, everything favors the small place, provided it can get an equal chance in the matter of transportation. But what does the actual experience, the actual development of the country, in the last thirty years, show?"

"It shows that the small towns have been practically standing still. They have been losing rather than gaining industries. Factories have been moving from the small towns to the cities, in the face of the fact that every possible inducement, save that of transportation opportunity, favors the small town.

"The parcels post is one of the things that will help to restore the balance."

Likewise, Representative Lewis of Maryland made a very strong address in favor of parcels post. Altogether, these gentlemen made a presentation of the case for parcels post that will not be improved in a long time; and they made a profound impression on the members of the post-office committee.

There is no serious obstacle now save to remove the impression, still powerful in the minds of many country merchants, that parcels service would ruin their business. The arguments on this point seem to me the best and most complete ever made in Congress.

## Everyone Can Know Why

**I** BELIEVE that if every country merchant would inform himself of just what has been said on the other side, the small-town opposition would soon vanish in favor of a more intelligent view.

I believe that if everybody, man, woman and child, would study the situation, there would be some action in Washington worth noticing, and it would be for the benefit of all.

I could wish nothing better for this cause than that every reader of *FARM AND FIRESIDE* would write to Representative Jas. T. Lloyd, and ask him for a copy of these hearings; then, that, having read and mastered them, he would constitute himself a missionary and set about it to line up the business men and the rest of the farmers in his vicinity on the subject. It would certainly assure a parcels post at the present Congress.

# Country Girls Who Can Do Things

Told by Jessie Field, Superintendent of Page County Schools, Iowa,  
and Marie Samuella Cromer, Originator Girls' Tomato  
Clubs, Aiken County, South Carolina



Marie Samuella Cromer, originator of Girls' Tomato Clubs

PAGE COUNTY, Iowa, located in the fertile corn-belt of the Middle West, claims that along its beautiful country roads, in its comfortable country homes, live girls who are as bright as any girls in the world. In fact, you need not be surprised should the people of this county tell you that their country girls can do more things and do them better than anywhere else.

And they have some ground for such a claim.

Why, their girls are champions along almost every line. In the first place, they are champion corn-raisers. Miss Frances Bengston, a thirteen-year-old country girl, living near Essex, in Page County, won the Sundberg Trophy at the State Corn Show at Des Moines last fall by exhibiting the best ten ears of corn in the junior class. She is a bright student and graduated from the eighth grade in spring.

Then, in sewing, they took every first prize and sweepstakes at the State Junior Industrial Exposition at Ames in January. They have the girl who made the best work-apron, and won a sewing-machine. And this same girl had the best hemming of any girl in the state. For that she was awarded a washing-machine. This girl, Blanche Ingram, lives near Clarinda and is now a student in high school. Miss Wilma Driftmier, who is also in high school now, a strong, thorough student, a country girl living north of Clarinda, had the best buttonholes shown by an Iowa girl. For this she is the proud possessor of a beautiful sewing-machine. Miss Jennie Lind had the best fancy white apron in the state. So you see these Page County girls can sew.

And—what will suit you best of all, I suppose—they can cook. Three country girls from Page County went to the state contest at Ames as a cooking team and brought home the state trophy as the best girls' cooking team in the state of Iowa. One of these girls won the Henry Wallace Medal for the best individual work in cooking and a splendid steel range for showing the best loaf of bread in the state. This girl was Ora Tompkins, and the other two girls on the team were Merle Bayless and Eva Linebaugh.

Then, just to show that their ability to do practical things had only made them stronger in their regular school-work, one of the girls, Nellie Copeland, entered the best essay of anyone in the state. So there you are. You see, Page County has a reason to be proud of its country girls. They understand sewing, cooking, reading, writing and arithmetic, and they know how to grow corn. What more could you ask?

But one thing, and this is the best of all. You might ask for girls who are sweet and modest, thoughtful and lady-like, not spoiled by success, but finding in it an added incentive to greater efforts themselves and more helpfulness to others. This, too, the country girls of Page County have, and it is a grace which comes to all girls who really learn to do things.

Here is the story of the Girls' Tomato Clubs, by Marie Samuella Cromer, originator of the idea:

While I was President of the Teachers' Association of Aiken County, South Carolina, I called a meeting of that body on Saturday morning, January 7, 1910. On this same day, C. H. Seigler, Superintendent of Education, called a meeting of the Boys' Corn Club. Mr. Ira Williams, State Agent of the Department of Agriculture, gave an address to the members of the Corn Club and to the teachers.

During this meeting I thought of the help and instruction the Department of Agriculture was giving to our boys and men, and I wondered why it was that nothing was being done to help and encourage our poor, little, handicapped, rural girls. When the meeting was over, I asked Mr. Williams why the department did not organize a club for the girls. A tired smile flitted over his face, then he replied: "Well, I suppose we have been asked this question fifteen hundred times. That's a problem for you teachers to solve. Why don't you organize a club for them?" I replied, "Just give me a little time, and I will certainly do this." One of the teachers standing near-by suggested a "Chrysanthemum Club." In an instant I realized that this was not what



Frances Bengston, age thirteen, who won the Sundberg Trophy at the State Corn Show at Des Moines

we needed. I wanted a club that would be of vital use to the people, and so I asked, "Why not organize a Tomato Club?" Mr. Williams replied, "Well, arrange your plans and send them to me, and if practical, the Department of Agriculture will help you all it can."

I selected the tomato for my club-work because for many years I have been interested in this fruit. It had been the dream of my life to be able to cultivate it. To me it is the most interesting single fruit in the world. Tomatoes are almost universally liked; they are beautiful; they are easily cultivated; they are ripening from early spring until late autumn; they may be kept for



The three girls who carried off the state trophy in the cooking contest, which was held at Ames, Iowa

some time so that they can be exhibited; they are enjoyed at breakfast, dinner and supper, and they may be used while green as well as after ripening. We can them; we stuff them; we eat them sliced; we make ketchup, preserves, tomato mincemeat, pickles, sauces, jelly and candy from them. We may eat them with sugar or eat them with salt. They are delightful any way we fix them.

The next week after my conversation with Mr. Williams, I was so busy with my school-room work and with the organization of Rural School Improvement Associations that my Tomato Club plans were not formed. The second week, however, the plans were outlined and forwarded to Mr. Williams. The plans

outlined met his approval. This is the history of the Aiken County Girls' Tomato Club, the first girls' canning club in the world.

The clubs are carried on in this manner: Any girl between the ages of nine and twenty years, in the county organized, may become a member. She must plant one tenth of an acre in tomatoes, and do all of the work connected with her garden, except preparing the soil for her plants. Prizes are offered for the largest yield, the largest net gain, best display in glass jars, best history of garden-work, largest tomato, most perfect tomato, largest, neatest and best collection of tomato recipes, original recipes, etc.

Through the press and through the mail I solicited members. When possible, I visited schools, gave talks and secured other members.

In May, I went to New England to spend the summer. While away the club was steadily gaining prestige. The Department of Agriculture gave me a position, and adopted the club.

The department gave to our club a canning outfit, three thousand cans and three thousand labels. Upon the labels is this inscription: "South Carolina Tomatoes. Grown and Packed by the Aiken County Girls' Tomato Club."

Canning-parties were given at the homes of the little girls, and public canning demonstrations were given at various points over the county. Large crowds attended these demonstrations. Instructions were given those present. Much interest was manifested, and I believe that more fruits and vegetables were canned last year than ever before.

Before the club had become recognized, several of the little girls had withdrawn. When the contest closed, only twenty-two had worked faithfully to the end. But these girls had demonstrated to the world the glory of labor and the merits of our Girls' Tomato Club.

This club does not stand for simply the raising of tomatoes. It stands for this and much more. It stands for lessons economic and lessons ethical. Through this club labor has been elevated, property is respected, and the good of coöperation demonstrated. The members of this club have come in contact with the problems of soil, drainage, pests, spraying, rotation of crops and of real money values; striving to reach a common goal and, last, but not least, rejoicing in the success of others.

These gardens have been an inspiration to whole neighborhoods. These little girls have seen how the tomato can be developed and improved, and thus a desire to improve other things has been created. To some it will mark the beginning of a life-work. To others it will teach many useful and valuable lessons.

Katie Gunter, of Samaria, filled 512 cans. She sold her tomatoes for fifty dollars. For this remarkable record the state legislature gave her a four-years' scholarship to Winthrop Normal and Industrial College, at Rock Hill, S. C., which is worth four hundred dollars.

After I returned from New England, I visited the members in their homes and gave them instructions in canning, preserving, pickling, and helped them make ketchup and jelly. While I was visiting some, I wrote letters to others to keep them encouraged. I wrote many letters to our newspapers to get the masses of the people interested and to further encourage the little girls.

In April, 1910, four months after my Tomato Club was organized in Aiken, Professor Martin, of the Department of Agriculture, gave an address in Virginia, in which he told of the Aiken County Girls' Tomato Club. The governor of Virginia was present and was so much impressed with the plan that he soon afterward took steps to have an organization of the same kind in that state. Miss Ella G. Agnew was appointed to organize clubs in the Old Dominion.

The Girls' Tomato Club is only a little over a year old and already there are over four thousand girls who are members of it. South Carolina, North Carolina, Virginia, Tennessee, Mississippi and Georgia have Girls' Tomato Clubs.

In a few short years I feel sure that we will have Girls' Tomato Clubs organized and doing useful, effective work in every state in the Union where tomatoes can be grown.



Lois Edmonds, champion hemmer, Page County



The first step in preparing the tomatoes for canning. All the work is done out of doors



A group of enthusiastic club members, showing their tomatoes canned and ready for the market



A busy morning for the members of the Tomato Club in Aiken County, Aiken, South Carolina

# What Might Have Been

Words by  
BARTLEY C. COSTELLO

Music by  
J. S. NATHAN  
Composer of { Pal of Mine, Señora,  
My Cavalier, Etc.

Andante moderato.



Voice.

What might have been! — Oh! sad, sweet thought; When mem - 'rys gates — are open - ed —  
I saw a boat — drift out to sea, — And watched it wend — its aim - less



wide, — what wist - full long - ing in my heart — to turn back Time's — re - lent - less  
way, — I pit - ied it, — for just like me, — 'twill drift a - long — from day to



tide; — To kiss your lips — of cher - ry red, — to smooth your hair — of gold - en  
day, — Un - cared for, with — no gui - ding hand, — to steer where wel - come bea - cons

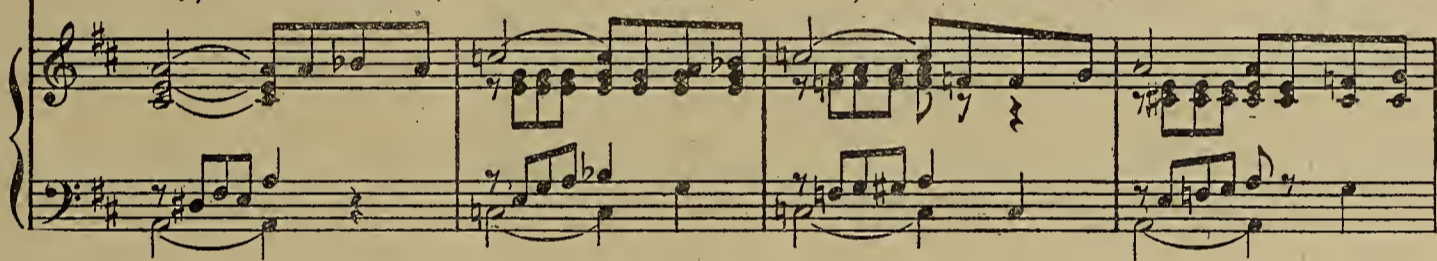

sheen; I won - der if — you too, like I, — Sigh ev - er for — what might have been! —  
gleam, Too late to turn — back to the past, — Too late now for — what might have been.



Chorus.

What might have been I dream of, sleep - ing, wak - ing, — How sad the day when doubt first came be -

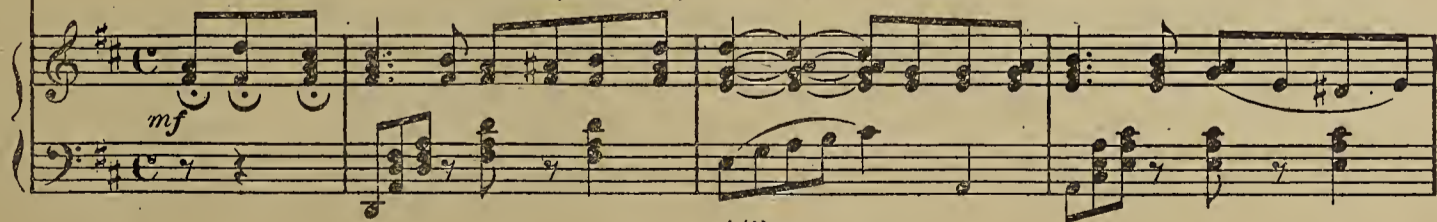

tween; — And Oh! my heart is sighing, aching, brea - king, And vain - ly long - ing for what might have been. —



Copyright by LEO FEIST "Feist Building" New York



Don't Use Laundry Soap on Your Face

## JAP ROSE

"The Bubble Bath Soap"

is unequalled for cleansing your skin because it is the original, transparent Toilet and Bath Soap and is absolutely pure. Because it is made of vegetable oils, it cleanses instantly, thoroughly and refreshingly. For genuine pleasure and satisfaction insist on getting

## JAP ROSE

Sold by dealers everywhere

REFUSE IMITATIONS

Look for the Jap Girl on every package.

A Large Cake for 10c



Established 1839

84

Do you realize how much quicker you can get

## Woman's Home Companion Patterns

than you could in the past and that it is because The Crowell Publishing Company has now established three different pattern-depots from which these Patterns can be ordered?

The pattern-depot addresses are as follows:

### Eastern Depot:

Farm and Fireside  
381 Fourth Avenue  
New York

### Central Depot:

Farm and Fireside  
Springfield, Ohio

### Western Depot:

Farm and Fireside  
1538 California Street  
Denver, Colorado

Send your order to the address nearest your home, enclosing ten cents for each pattern desired, and immediately your order will be filled.

## DAISY FLY KILLER



placed anywhere, attracts and kills all flies. Neat, clean, ornamental, convenient, cheap. Lasts all season. Made of metal, cannot spill or injure anything. Guaranteed effective. Of all dealers or sent prepaid for 20 cents. HAROLD SOMERS 150 DeKalb Ave. Brooklyn, N. Y.

## DON'T PAY TWO PRICES

Save \$18.00 to \$22.00 on

## HOOSIER RANGES

AND HEATERS

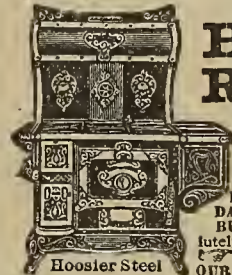

Why not buy the best when you can buy them at such low, unheard-of Factory Prices? THIRTY DAYS FREE TRIAL BEFORE YOU BUY. Our new improvements absolutely surpass anything ever produced. SEND POSTAL TODAY FOR OUR FREE CATALOG AND PRICES.

Hoosier Steel HOOSIER STOVE FACTORY 126 State St. Marion, Ind.

# On a Thousand Hills

A Story of Duty Versus Selfishness—By Paul Crissey

Drawing by Charles S. Corson

FOR uncounted days the long, low, rambling farmhouse had been as quiet as the deep woods which lay just across the road beyond the brook, that tore with diminutive rage at its banks. Even the plain-faced woman within slipped about from room to room with the softness of the rain which had fallen as quietly as a heavy mist upon the outside world. People had spoken softly of late, and even old Jim, the hired man, had picked his way with clumsy carefulness as he went about his chores. And within this pall of quiet, within this abode of soft-spoken depression, Eunice had sat and listened to the big-tongued clock on the parlor shelf as it ticked away each long hour with inconsiderate boisterousness.

With her white, oldish face pressed close against the window-pane, she had turned her eyes first up, then down the muddy road, as if waiting for something which the very atmosphere of the place seemed to whisper was to be expected. But it was not from down the road, nor from up the road, nor from across the great swampy flats behind the place, that the dread visitor approached the quiet farmhouse and its expectant inhabitants.

Instead, as if through the half-opened window of the darkened "best chamber" up-stairs, he wafted in, his somber colors indistinguishable in the first dusk of evening.

For the first time in the three weary days, the white figure on the bed in that best room stirred faintly, very faintly.

Aunt Toto looked up from the rocking-chair, where she was seated in silent reverie, and bent for a second over the woman on the bed. If those wasted lips formed not the words of the thought within, the eyes did, and Aunt Toto, with an instinct born of experience, knew and understood.

Silently she crept to the stairway and noiselessly passed down into the big, lonesome parlor. Eunice sat before the window, and the silent steps behind her were as totally ignored as the picture-books and the long-suffering dolls which lay discarded in the dark corner beside her. At the touch of her aunt's hand on her shoulder the little girl flinched as if hurt. But the kindly voice reassured her.

"Come, dear," she said, "she wants to see you."

Quite eagerly, as if to prove to the heart within her that all its doubts and fears were out of place, the little girl rose and followed, stiff-legged and weary, to the silent room above. Once more there was a vague whispering of the bed-clothes and, with the choking sob of a very little girl, very hungry for a mother's love, Eunice laid her wet, flushed face against her mother's thin, bloodless one. But in the dusk of twilight that somber Visitor had already entered, and the lowered shade swung listlessly in the damp air.

Faint as the beat of a new-born heart the words of the mother crossed her lips and hung, delicious but heart-breaking, upon the ears of her daughter.

"Eunice—my little Blossom!" And the Visitor had accomplished his errand.

The mother's eyes were fixed upon Eunice—upon her little Blossom, as she called her. A while they lingered there, speaking of hope and love and faith, then, like the rare perfume of a rose, they slowly faded out. The silent bed and the softly sobbing girl were left alone in the dark room.

And thus it was that Eunice, barely eight years old, became an orphan, and at the same time a subject of much discussion in Hickory Center. The days of settlement of the tiny household were but a weary length of time which pointed to a future and a new life for the little girl. She had come back from the moist, leaf-strewn grave on the West Hill, only to sit in her accustomed place in the gloomy front window and play with her thoughts, disregarding those about her. The dolls and books and childish toys had been pushed further back than ever into the corner that seemed deeper and darker than it had ever before. Gradually, under the kind aunt's care, the house had been swept barren, and on the third day, after the great sorrow had been laid away in the store-chest of memory, Eunice was led, blinking and unwilling, into the light and wholesome warmth of the kitchen.

The plain, kindly face of Aunt Toto gazed deep into her own, and the tired little girl realized, suddenly, that life was about to be resumed once more. Aunt Toto took the tiny figure in her arms and held her close for a brief moment to her well-nourished figure.

"Eunice," she said slowly, "you have been pretty quiet these last few days. Don't you think it is about time you said something—or did something? You can't go on this way—you've got to live and you must make the best of it." Her voice was gently insistent.

Eunice nodded wisely.

"I've been thinking it over," she replied quaintly, with a nod of her head toward the deserted parlor, "in there. Where am I going to live?" The last in a puzzled tone.

"Bless my soul!" cried Aunt Toto, "you took the words clean out of my mouth—I mean—" she concluded, flustered, "I mean I was thinking of that myself. What a little lady you are, dear!" She smiled, a quizzical, puzzled smile, at the little girl on her lap. Eunice came to a sudden interest in the subject at hand.



"Down the road she trudged, grasping the stiff finger of the big man by her side"

"Do you know, Aunt?" Eunice asked quite suddenly.

"Do I know? What?" quizzed Aunt Toto.

"Do you know where I am to live?" Her eyes followed those of her aunt, as they wandered about the room for an answer.

"No, I'm afraid I don't," the woman answered quite frankly after a moment. "Do you want to live with me?" Their eyes met in doubtful hesitancy about the answer to the question. Eunice regarded her for a moment.

"No," she replied quite composedly. "I don't believe I do. You see," she supplemented kindly, "you have so many boys and girls at your house that maybe there wouldn't be enough to go around."

"Enough to go around," mused Aunt Toto to herself. "Children enough now, but food and clothes—and shoes—oh, dear!" She gave a motherly sigh and clasped Eunice still tighter in her arms.

"Listen, dear," she said. "When your sweet little mother left us, there wasn't any money or anything that didn't belong to the doctor, indirectly. I am the only relative you have who cares for you, and I have so many little children that I—but there, you said you didn't care about living with me. Now the question we have both got to solve is, what we will do with you."

"Oh," said Eunice coldly, "I have decided that already, Aunt Toto. You see, I've been thinking a lot lately, and I want to live in the woods. It's nice and cool there, and damp—and full of funny smells and lots of queer things to find down in the leaves. I am going to live in the woods with a man."

Aunt Toto, with these words, came suddenly to a prim and almost indignant posture.

"Child!" she exclaimed, "who has been putting that sort of rubbish into your head? I've expected queer things of you, but this—this—who is the MAN?"

"He's big and tall," she began a stereotyped description, "and I've only seen him once or twice. He's got gray hair that's all curled close to his head, and his hands are big and hard and rough. But he's awfully nice and his voice is soft. He lives in a little house away up in the west woods, and one of his fingers is bent and it won't uncurl." She paused, breathless, with the light of eagerness blazing in her small eyes.

Aunt Toto was on her feet in an instant, and it was with difficulty that that good lady smothered an unkind comment. Noiselessly she began to pace the room.

"Eunice," she said, stopping suddenly, "do you know that quite contrary to your own nature and quite like the custom of other little girls, you have asked for the one thing that is hardest to get for you? It would be easier," she added slowly, "to get blood from a stone than to get your tight-fisted uncle to undertake the job of raising you. He is a miser!"

"He is not a miser," exclaimed the little girl suddenly, her eyes snapping with resentment, "he is good and kind—and he will take me to live with him, I just know he will."

Aghast at this odd defense, Aunt Toto recalled her attack and gathered, with great concern, the now sobbing little girl in her arms.

"There, there," she soothed, "maybe he will take you. We'll see about it."

"I'll go and see that man of yours with the crooked finger." She smiled to herself, half bitterly, and with a few decided jerks clapped on her bonnet and the rusty black cape she was wont to wear upon such occasions.

Old Jim harnessed her horse to the clay-plastered buggy, and with a wave of her hand to the sad little face, prematurely old, Aunt Toto set off at a goodly pace down the rain-filled ruts in the road toward the almost forgotten territory where lived the silent man of the little girl's dreams.

Aunt Toto's teeth clicked together with a sudden determination as she finally drew up the reins and stepped out of the buggy to meet the tall man who stood silently regarding her with a mild, dulled surprise showing in his face.

"Well, brother," she remarked amiably, as she swished her skirts from the muddy wheel. "It has been some time since we met."

"A long time, Esto," her brother replied, shaking his shaggy head.

"You look prosperous enough," answered Aunt Toto, stepping into the small, spotless kitchen, "but, like all men of your sort, you lack a needful thing—that's a woman."

A twinkle suddenly showed itself in the big man's eyes as his knotted hands placed a chair near the stove.

"Ain't going to try to marry me off, are you, Esto?" he answered half reproachfully.

Aunt Toto sniffed.

"Not that, Merrill," she replied emphatically. "Your days—and mine—are over for marrying."

The old man nodded and stretched out his expansive feet toward the stove. Merrill Warren was a stalwart man. His whole appearance was a heart full of the sap of human sympathy. His hands had knotted and hardened as he wrestled with the stern conditions of life. His hands, his face and the build of his body, as well as the wreaths of wrinkles in his face, seemed to tell that all he had gained had come from struggle.

"I came here to-day for a certain purpose," began Aunt Toto, "and I want you, Merrill, to consider carefully what I have to say. Jennie, my sister—and yours, too, Merrill, if you haven't forgotten it—is gone from us. She was all alone, except for a little girl eight years old. Merrill, there's nothing but the county-house ahead of her. Everything on the farm is taken. I've too many children of my own, and too little to do with to take her. I can't do it. When I asked Eunice who she would rather live with, she said, 'the man with the crooked finger.' Take her, Merrill, and make her happy."

Dumbly the old man rubbed his stiff, bent finger and drove it silently, forcefully, into his open palm, time after time. Sorrow, a kind of speechless, deep sorrow, showed in his mild eyes, and several times he cleared his throat as if to speak.

"Take her, Merrill," Aunt Toto pleaded, bending forward in her eagerness, "you have plenty and you'll like her. You are the man of her childish dreams—don't turn those dreams into horrors by making her go to the county-house!" Tears poised for a moment on the good woman's eyelids, but determinedly she wiped them away.

"I can't, I can't!" replied the old man brokenly.

"Why can't you—because you won't?"

"Not that," he muttered in answer.

"Why, then—she is your own sister's little girl. Eunice—take her, Merrill," Aunt Toto pleaded.

"I can't take her," the man half gasped. "It would ruin all my plans. My life would be upset."

"Your plans; come, what do you mean?"

"Ever since I was a boy," he answered, with a strange curl to his lips, and his voice was low and insistent, "I have worked for the time when I might do as I wished, live as I wished, with neither care nor worry to haunt me. When I could live without work, when I could earn a rest for what was left of my life, then I would be happy. For fifty-odd years or more I have struggled for just that much of my share in the world. I have nearly broken my body at times, but never my spirit. This week I reached the point in my life and in my savings where I can stop my work. I can live comfortably for the remainder of my days. I am independent. I shall not work. A half-century lies behind me, but a hundred centuries of pleasure lie before me, now that I have gained my end. Shall I give up that for which I have given my life—for eight years of one I know nothing of?"

His eloquence was drowned in the burst of indignation which gushed from Aunt Toto's lips.

"Merrill Warren!" she said distinctly, "I have called you many hard names in my life. I have thought of you as a miser, as a hermit and as everything except a

[CONCLUDED ON PAGE 19]



## The Jewel in Your Heart

By Edgar L. Vincent

**D**ON'T you like to look at things which have cost a bit of the very heart of some man or woman?

Finished things always have a charm about them. A boy I knew away back in my school-boy days had dreadfully hard work to understand books. It seemed as though he never could learn the meaning of "six times one are six," but in the odd moments, when the teacher was not looking, that lad would be whittling away with his knife and a soft pine stick; then, by and by, when we were out at recess, he would show us some beautiful thing he had carved out. It looked so wonderful to us! We forgot the boy's bungling over his books; the beauty of his little creations was enough to awaken our envy and set us all to whittling when we thought we would not be caught in the school-room.

Pieces of furniture that have been finished, pictures that are all done and now hang in the gallery, statues all polished and wrought out with infinite patience, gems cut by days of labor—these all have a charm for us.

Looking at them, we forget the work they cost. When we are told that some little creature turned pain into a beautiful pearl, the words fall on dull ears; our hearts are enraptured by the glory of the gem—what does it matter how much of pain it may have cost? But isn't this just because we do not care to look below the surface and read the story written there?

In all the world, there is nothing more beautiful to me than the face of a man or a woman who has somehow taken life's experiences and turned them into a beauty of face, of expression, of character that shows itself in calmness of soul under every pressure of circumstances, a steady, earnest manner of living which is at once our envy and our despair. We know there have been storms in that life—only so could the peace have been gained; the chisel has been cutting deep while the years have rolled on; in no other way could the perfect lines have been wrought out in face and in form. But we forget the storms; the hurt of the chisel passes for naught; and we think only of the perfect man.

A woman I knew—she lived away back among the hills in a quiet place where the world never could have found her—worked out for herself this jewel of the heart which made her so beautiful! All

alone she put her shoulder under the farm wheel and tugged away till she had turned what had been defeat for her husband in his lifetime into success. The old farm became a beauty-spot. It gave back a liberal return for the work done upon it.

When the curtain of hard times began to lift a bit so that she could almost see through to days full of peace and rest and comfort, she took her only son, a lad of nineteen, and two or three other farmer lads of the neighborhood, and went away with them to an agricultural college. Here she stayed with those young men, mothering them, loving them, holding them true to their high purpose and shielding them from the temptations which so often come to those who are away at school, until they had finished their course and were ready to go back to the farm and take better places than they ever otherwise could have taken. It was a lovely thing for that woman to do. Never as long as they live will the boys ever know just how much they owe her.

And while she was thus giving of her very life to the work of lifting up the boys, she was hewing out for herself a glory of face and of character that will shine forever.

There are those who think it a bit hard that, just as she was coming to look through the shadows to a bright day for herself, he should call her away. To those who do not understand it seems as if she had been taken away from what might have been the happiest, most restful part of her life. But don't you think he had something even better for her? The jewel had all been carved out. The hurt had been turned into a pearl. The chisel had perfected the loveliness of the statue, and through all time what she did will be told to make men better and nobler. And her boy is the very jewel of her heart!

The jewel in your heart will be of your own carving. Frosts, droughts, storms, failures, hard experiences—what are these but the things that are used to bring us beauty of life and character? We laugh and we cry; we wonder and we doubt; we reach up through the darkness and call out for help when things go hard with us; but we do not always see that in our souls a gem is being wrought out that will glorify us some day.

And the thing that gives life its greatest glory is the lift upward we give to some other soul! How are you carrying the jewel in your heart?

## Gleaning the Handfuls

By Orin Edson Crooker

**M**AN set out to accomplish a great task. He was years in the doing of it. All this time he looked forward to the day when it should be finished and his hopes should be realized. He felt that he would be perfectly happy when his ambition should be fulfilled.

At last the task was done, and he sat down to enjoy himself. But he had worked so hard all these years that idleness did not become him in the least. Time became irksome on his hands. The great happiness which he had expected to find when he had attained the goal of his labors was somehow not so entirely evident as he had expected. Then a strange thing happened.

His mind, which hitherto had been dwelling upon the future, began to turn to the past. He found himself longing for the companionships of those who had been fellow toilers with him in his struggles; he yearned for the return of the old experiences. Slowly it began to dawn upon him that, while he had not realized it at the time, the real joys and blessings of his life had been the experiences, the fellowships and companionships of the years during which he had toiled and struggled toward the attainment of his great ambition—an ambition, which, when realized, crumpled under his touch like roses which have withered and dried.

The real happiness of life is always found in the small gleanings along the way. Life must be lived on the installment plan, a day at a time. The handfuls of contentment and joy which we unconsciously gather from day to day constitute the real savour of life and afford the material around which memory paints the brightest pictures of our life experience.

Like old photographs, which we value because the scenes they picture cannot be duplicated, so the heart treasures the memory of times past and gone, and in the perspective which the years lend we can see how we walked amid scenes of beauty and knew it not, and how the blessings which we gleaned unconsciously and a little at a time along the way were blessings which really gave the tone and color to the memories we now cherish.

### Trouble

By Orin Edson Crooker

**T**HERE is no one who does not have his troubles. Your neighbor may not have your troubles, but he has his own—though perhaps of a different kind. If you knew just what they are you would probably rejoice that he has his and you have your own.

The Czar of Russia does not need to worry about his house rent or his grocery bills, but the crowned head of 100,000,000 people lives in constant dread and fear of plots against his life. Would you exchange troubles with him if you had the chance?

You may have a heavy burden to carry, but did you ever stop to think what a blessing it is that God has given you strength to carry it?

If you wait until you have no troubles before you cheer up, you will walk a dismal path through shadows to the grave. Carry your troubles with a hopeful heart, it lightens the burden to make as little of them as possible.

Lots of people borrow trouble, in which case they usually have to pay good interest for the use of it. Do not anticipate the difficulties and discouragements of tomorrow. No hill is quite so steep as it appears from a distance.

## "Mother"

**I**T IS said that it is difficult to advertise good fiction. Whether that be true or not, there is one thing we know absolutely: human beings like to read unusual stories.

**W**HAT we started to mention is "Mother." "Mother" is the title of a truly wonderful story in the August AMERICAN MAGAZINE. The author is Kathleen Norris, a new writer of great powers. This story "Mother," which will live, is an extraordinary presentation of the important and unselfish service which mothers perform. Children oftentimes stray away from an understanding of it. But they come back to their senses—in gladness and wonder. You will remember this story.

**W**E ARE talking about unusual fiction. Edna Ferber's story in the August AMERICAN MAGAZINE is unusual. Miss Ferber, a very young Chicago author, is one of THE AMERICAN'S great new "finds." The newspapers and literary critics are talking about her talent. Her gift is considerably like that of the late O. Henry.

**V**IRGINIA TRACY'S story in the August AMERICAN MAGAZINE is unusual. It is the story of a husband and wife in the theatrical profession. It is a story of the *selfishness of genius*. The surprise in store at the end of the story will fairly take your breath away when you come onto it.

**T**HE articles and departments in THE AMERICAN MAGAZINE are famous for their liveliness and authority. Following is a list of notable things in the August number—all in addition to the fiction already mentioned:

"The Abandoned Farm"—an article telling what is happening to the abandoned farm, especially in New England.

"The Cost of a Quarrel"—a full account of the longest strike on record. It still drags on, in Pennsylvania, where for 16 months it has cost lives, suffering, and millions of dollars.

"A Friend at Court"—a character sketch of Justice Harlan of the Supreme Court, who is a friend of the people.

"Interesting People"—great full-page portraits, and brilliant little pen pictures.

"The Interpreter's House"—the best and most original editorial section published in this country.

"Stars of Recent Successes"—our theatrical department. Eight full-page portraits in August.

"Watch His Arm"—another great baseball article by Hugh Fullerton. Filled with stories and illustrations.

"The Pilgrim's Scrip"—which contains a world of frankness and natural expression.

We will send THE AMERICAN MAGAZINE to any FARM AND FIRESIDE reader for a year for \$1.50, and the WOMAN'S HOME COMPANION for a year for \$1.50. We will send both THE AMERICAN MAGAZINE and WOMAN'S HOME COMPANION, each for a whole year, for the special price of \$2.20.

## THE AMERICAN MAGAZINE

381 Fourth Avenue, New York City



You want more than beauty in cotton dress-goods. Get a superior quality "worth making up."

**Simpson-Eddystone**  
Fast Black Shepherd Plaids and Stripes are calicoes of unusually neat and stylish effects in varied artistic designs, but added to these are their substantially woven cotton cloths, and the tub-proof, light-proof, and perspiration-proof color which commend them as dress-goods of durability and economy. The standard Prints of the U. S. for 68 years. Show this advertisement to your dealer when you order, and don't accept substitutes. If not in your dealer's stock write us his name and address. We'll help him supply you. **The Eddystone Mfg. Co., Philad'a**  
Founded 1842 by Wm. Simpson Sr.

# Clothes that Busy Women Need

Designed by Grace Margaret Gould

**E**VEN if summer is a busy season and there is little time for sewing, there are always one or two extra dresses needed. It is necessary, therefore, to have clothes that are easily made and that can be made in a hurry. One-piece dresses are the best for the woman whose time is limited, and illustrated on this page are several one-piece dresses, besides a practical apron and a comfortable summer wrapper. The design in No. 1413 is very attractive and would make a pretty dress for afternoon and church. The long panel in front, though easily made, gives it an especially graceful line. For a simple morning or afternoon dress, pattern No. 1610 would be stylish if made of plain madras, with trimming-bands of striped gingham or linen. In the center of this page is illustrated a good-looking shirt-waist dress, while at the bottom of the page is shown the wrapper which can be made in two styles and a new, very comfortable apron. Remember, the pattern for each of the practical designs shown on this page costs only ten cents.

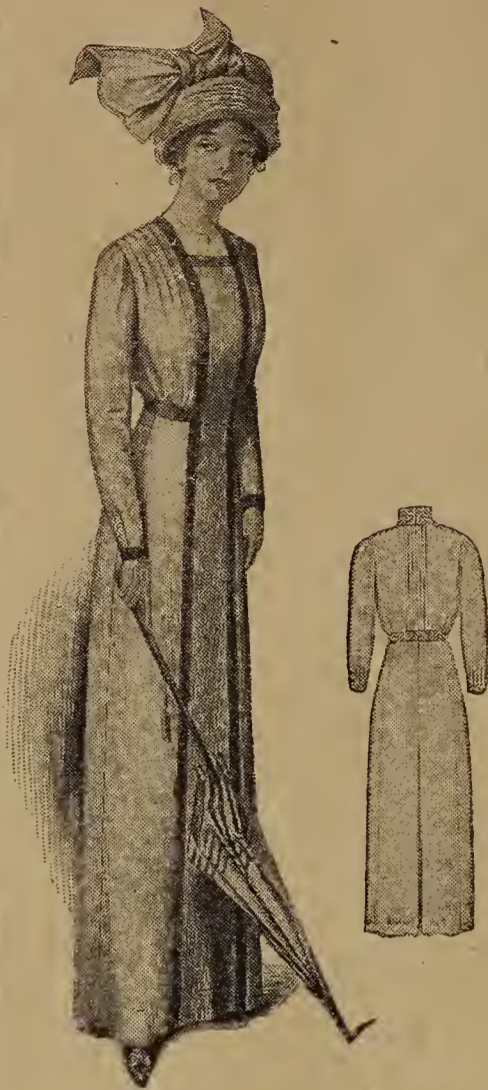

No. 1413—House Dress with Princess Panel

Pattern cut for 32, 34, 36, 38, 40 and 42 inch bust measures. Quantity of material required for 36-inch bust, nine yards of twenty-seven-inch material

**T**HIS is the style of costume that is just suited to the woman who cares for smart clothes, but simple in design clothes. Because of the straight princess effect, the dress will give slender lines to the woman who is a trifle stout. It is a good model for many occasions. It may be developed in linen or madras and worn about the house or the dress could be kept for one's best costume and be made up in voile or silk and trimmed with silk braid.



No. 1610—Morning Dress with or without Flounce

Pattern cut for 32, 34, 36, 38, 40, 42 and 44 inch bust measures. Material required for 38-inch bust, five-and-one-half yards of twenty-four-inch material

**F**OR warm weather wear, the model illustrated above is a very sensible little gown. It can be made with or without the flounce, and the waist and skirt are joined beneath the belt. The dress is extremely simple to make, in fact, all the WOMAN'S HOME COMPANION patterns are so easy to use that even the woman who has had little experience in sewing can, with their aid, easily become her own dressmaker. Every piece of the pattern is carefully and plainly lettered.

## This Beautiful Sugar-Shell Without Cost

**W**E WANT to send you this beautiful Oxford Silver Sugar-Shell, made by Rogers Company. It is made of



heavy plate silver. Entire spoon is six inches long, handle is four inches long, beautifully carved and embossed in the Narcissus pattern and finished in the popular gray French style. The bowl is two inches long and one-and-one-half inches wide, with a beautifully carved and deeply embossed Narcissus in the bottom. It is finished in highly polished silver plate. We guarantee this spoon to be genuine Oxford Silver Plate. If you are not perfectly satisfied, you can return the spoon and we will refund your money. We want to send it to you just to show you how you can earn a set of six

Oxford Silver Teaspoons just like it without a cent of outlay, for a slight favor on your part.

### SEND ONLY TEN CENTS

and one three-months' subscription to FARM AND FIRESIDE, and we will mail you, in addition, a genuine Oxford Sugar-Shell, as described above. The Sugar-Shell will be yours to keep, all we ask is that you agree to show it to two of your friends.

Address all orders to

**Farm and Fireside**  
Springfield, Ohio

No. 1656—Housework Dress, Buttoned in Front

Pattern cut for 32, 34, 36, 38, 40, 42 and 44 inch bust measures. Quantity of material required for medium size, or 36-inch bust, ten yards of twenty-seven-inch material, or seven-and-one-fourth yards of thirty-six-inch material. Any of the new summer ginghams or percales would be pretty developed like this design. The waist is very good style. It is plain in the back, and in the front there is a hem through which the waist is buttoned. The skirt also buttons down the middle of the front



No. 1798—Housework Apron, High or Low Neck

Pattern cut for 32, 34, 36, 38, 40, 42 and 44 inch bust measures. Quantity of material required for medium size, or 36-inch bust, seven yards of twenty-seven-inch material, or five yards of thirty-six-inch material. For low-neck apron, one-and-one-half yards less of twenty-seven-inch material, or one-and-one-fourth yards less of thirty-six-inch material, will be required

### How to Get the Patterns

If you want your summer clothes to be right in style and yet practical, use the famous WOMAN'S HOME COMPANION patterns which we supply at the low price of ten cents each.

So great has been the demand among FARM AND FIRESIDE readers for our WOMAN'S HOME COMPANION patterns, that we have established three offices or depots from which these patterns can be obtained, as follows:

FARM AND FIRESIDE, 381 Fourth Avenue, New York; FARM AND FIRESIDE, Springfield, Ohio, or FARM AND FIRESIDE, 1538 California Street, Denver, Colorado.

We suggest that you send your order to the depot that is nearest to you to facilitate the quick delivery of the pattern.

### A Premium Offer

To any FARM AND FIRESIDE reader who sends us one new subscription to FARM AND FIRESIDE with fifty cents for the same, we will give as a premium for the subscription one WOMAN'S HOME COMPANION pattern. To obtain a pattern without cost, send the subscription to FARM AND FIRESIDE, Springfield, Ohio.



No. 1769—Double-Breasted Wrapper, High or Low Neck

Pattern cut for 32, 34, 36, 38, 40, 42 and 44 inch bust measures. Quantity of material required for medium size, or 36-inch bust, nine-and-one-fourth yards of twenty-seven-inch material, or seven-and-one-fourth yards of thirty-six-inch material. If the flounce is used, an additional one-and-three-eighths yards of twenty-seven-inch, or one-and-one-eighth yards of thirty-six-inch material, will be required

I Trust You Ten Days. Send No Money. \$2 Hair Switch Sent on Approval. Choice of Natural wavy or straight hair. Send a lock of your hair, and we will mail a 22 inch short stem fine human hair switch to match. If you find it a big bargain remit \$2 in ten days, or sell 3 and EARN YOUR OWN SWITCH. Extra shades a little more. Inclose 5c postage. Free beauty book showing latest style of hair dressing—also high grade switches, pompadours, wigs, pulls, etc. Women wanted to sell our hair goods.  
Ama Ayers, Dept. A230, 22 Quincy St., Chicago

# OUR YOUNG FOLKS' DEPARTMENT



## The Letter-Box

## The Cats of Manxland

By Alice Jean Cleator

## Cousin Sally's Club

WHY don't you join our club and learn the secret of our monogram? The club button costs five cents and I know you will be delighted with it. I am sending them out by the hundreds, and it is astonishing the way the club is growing. If you are not older than seventeen you are eligible for membership. When joining, state age, and address Cousin Sally's Club, FARM AND FIRESIDE, 381 Fourth Avenue, New York. We are always glad to welcome new members.

DEAR COUSIN SALLY—  
I am a country girl ten years old. I go to school. I am in the fifth grade. I had a little garden last summer, and I raised different kinds of vegetables.

One day when I was playing I heard something splashing the water in a tub near by. I ran and looked in the tub and found a helpless young bird in the water. It must have fallen from the tree above the tub. I took it out and carried it into the house. I fed it and dried its feathers, and in a few days it flew about the rooms. Then I let it go and it flew away. Your friend,

LUCY C. ANANUER,  
Sand Creek Road,  
West Albany, New York.

YOU see, there's one place in the world, at least, where the small boy doesn't often have the fun of pulling the cat's tail," laughed one of the Islanders in the little fifteen-by-thirty-mile Isle of Man in the Irish Sea.

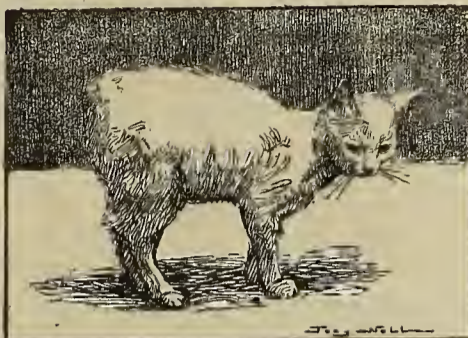

A Manx cat from the Isle of Man

We were watching some Manx kittens frolicking and tumbling about on the lawn. "And, by the way," he continued, "have you ever seen a Manx cat try to run around a corner? You see, it hasn't even the apology for a tail. The tail acts as a rudder with the ordinary cat in any such performance as that and steers it safely. A Manx cat will seldom try this 'stunt,' instinct telling it that it's an almost impossible feat; but occasionally such a thing happens, and it usually ends in a ludicrous tumble."

The longer I stayed in the Island, the more I saw of these charming little pets. One sees them everywhere—sometimes jumping like rabbits from the gorse and fuchsia hedges, leisurely walking the streets of the little fishing towns, or stretched lazily in the sun outside the tiny whitewashed cottages, or in the beautiful gardens of the more pretentious villas.

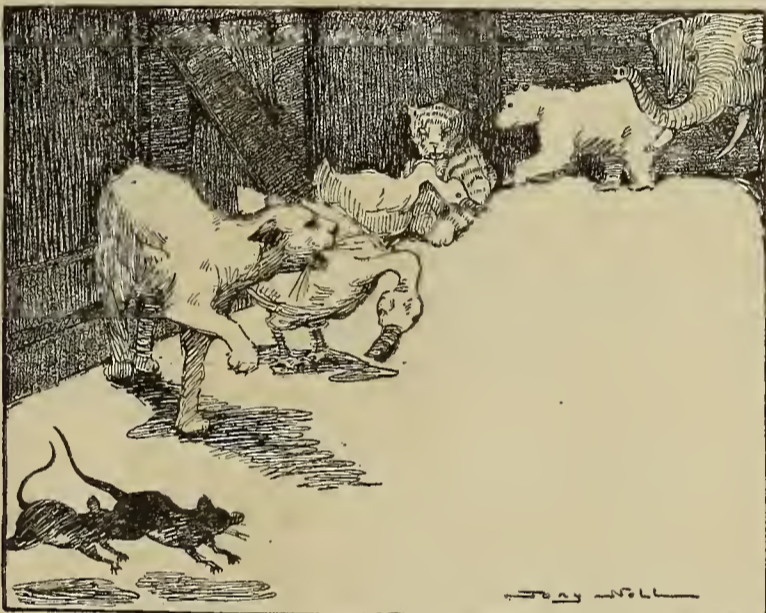

"The cat from mousing came in late. Alas! the door cut off her tail!"

Sometimes one comes upon an odd-looking group, as I did one day when passing a charming home almost buried in a glory of rose and fuchsia bushes. This group comprised a fierce-looking black cat with a full-length tail, a half-breed Manx cat with half a tail, a full-breed cat with no tail and a long-tailed smoke-colored cat from the Shetland Isles. The latter are at present very popular in the Isle of Man.

The Manx cat has a smaller head, longer hind legs and shorter body than the ordinary cat. They run and jump much like rabbits, and have a fox's queer way of looking at you as if reading your thoughts.

"I believe there are as many Manx cats in Cleveland, Ohio, or San Francisco, as in the Island," said one of the Islanders to me. "Large numbers have been brought to those

cities." Many are also brought to England as gifts. Half a crown is often charged for these pets and sometimes a much higher price. The cat-shows of the Island present a fine showing.

Long ago, when the Isle of Man was ruled by the Cambrian princes, the value of a cat was set by law. One of the old Manx laws reads as follows: "The price of a kitten before it can see is a penny. After it can catch a mouse, two pence; and after it catches a mouse, four pence."

We are also told that if the kitten proved not perfect in sight or hearing, or if dull of claws, the seller must forfeit to the buyer one third of its value.

The Manx cat has a fine "sense of location," as a phrenologist would say, and if taken long distances, can find its way back if it wishes.

In Pierre Loti's "Book of Pity and of Death" we are told of the supreme trustfulness which a cat places in one it loves. This is especially true of the Manx cat. It is more suspicious than other cats, but once it becomes attached to a person, its whole heart is given unreservedly.

Some time ago, I owned a Manx cat which had some amusing and interesting ways. One of these was that when her kittens for some reason did not act to suit the notions of their "mummy," she would take them in turn and slap their ears soundly, then look at them crossly as if to say, "There! I guess you'll mind now."

The Isle of Man, like all countries with an ancient history, abounds in fascinating legends. There are several legends in regard to the origin of the Manx cat. One of these I have woven into a little rhyme:

'Twas time to close the ark's great door,  
And Noah said, "Now, let me see!  
Are they all in?—the tiger, bear,  
The panther, dog and chimpanzee—

"Lion and wolf and elephant,  
Leopard and fox! Are they all in?  
If so, I'll shut the door at last  
And our long journey we'll begin."

But just as Noah slammed the door,  
Preparing for the ocean-sail,  
The cat from mousing came in late.  
Alas! the door cut off her tail!

Puss from the window jumped and ran,  
Was rescued, loudly purred her thanks.  
She landed on the Isle of Man  
And ever after was called Manx!

## On a Thousand Hills

[CONTINUED FROM PAGE 16]

brother, but you are not these. You are only a sufferer from something a great deal worse—selfishness. Live your life, but don't instill your one-sided, ungodly creed into any of my flesh and blood. It is a taint that God alone can wash from you."

And then, as the old man sat silent and unresponsive, she jerked on her hat and cape, and in a moment more was off down the road again with spray flying merrily from the whirling wheels.

Dry-eyed and stiff-lipped, the old man followed her with his eyes until the blue of the distant hills cut her off from his sight. Without so much as a look at the little house, he set off through the woods, aimless, but with the sting of his first real lesson ringing, throbbing, through his being. The friendly trees bowed to him as if in reverence to him who might some day conquer them, and the ferns peeped out from underneath the ground-padding of leaves, as if anxious to catch a glimpse of him.

But the creed of a new life had come to the wrestler of a half-century. His own people, his own world, had turned against him because of his ambitions.

"I can't, I can't!" he muttered over and over, and the quick-bodied little chipmunk heard him mutter as he passed. "My work is done—I am old and two cannot live on what I have saved!"

But the chipmunk knew, and he chattered about it to his friends, and soon the strange people of the woodland knew and talked about it. After hours and hours of weary, aimless striving, Merrill suddenly became aware of a difference in the woods. He was in a tiny valley where the leaves rustled quietly; where the myriads of the fingers of the trees plied nervously and the odors of the place begged opportunity to soothe him in his mood. And he gave up.

Seated on a log, he looked about in dumb wonder. A pile of fresh, soggy woodland mold lay upheaved before him. Only the chatter of a squirrel back in the thicker woods made him know of life there. Softly, swiftly and unerringly the frame of the great man fell upon its knees in reverence and his gnarled hand which bore the stiffened finger touched the grave before him with a tender caress. His voice, steady, pleading in great sobs, raised itself upon the forest stillness.

"Cleanse me, oh, Lord," he prayed, "and show me the right way, for her sake!" A dry leaf rustled noisily over the spot of bare ground, and Merrill rose rapidly to his feet and set off in the direction of the road. There was a great peace in his heart and the way lay clear before him.

An oldish face pressed close to the pane of a window of the deserted parlor saw a giant figure, full of determination, push silently out of the jungle which bordered the west woods.

"He is coming for me!" she whispered to herself, "I knew, I knew he would."

Aunt Toto, placid, free from unnecessary triumph, rolled the little girl's clothes in a tight bundle and kissed her good-by. Down the road she trudged, grasping the stiff finger of the big man by her side. In deep silence they passed from the view of the house and mingled with the mist of the hills. The sun was setting and its blurred, heavily golden rays emblazoned the outline of Big Mound. A lone string of cattle passed hurriedly in line over the brow of the hill and disappeared.

Raising his right hand toward nature's own picture, Merrill pointed his bent finger, trembling with feeling, and spoke the words which gave him peace:

"The cattle on a thousand hills are His. He will surely care for us."

And stooping suddenly, the lonely old man gathered up the tiny figure at his side and put her womanly little face close to his rough cheek.

"Dear Eunice—for her sake!" And the mist in his eyes was as blue as that which hung in kindly folds about the silent grave where he had gained his victory.

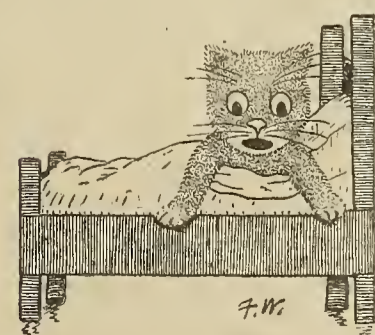

This cat was sent to buy some bread. And brought a yeast-cake back instead— That's why you see her now in bed.

DEAR COUSIN SALLY—  
I will write and tell you how very much I like our page. I think the stories are just fine.

I correspond with about one hundred of the cousins.

I am going to get a lot of my schoolmates to join C. S. C.

I go to school and am in the eighth grade. Our school closed April 10th.

Wishing the club much success, I remain  
Your loving cousin,  
R. F. D. 2, Big Run, Pennsylvania.

DEAR COUSIN SALLY—  
I am sending five cents for a club button. I read our page every time, and I think it is fine. I enjoy the stories.

I live sixteen miles from the Pacific Ocean, and when it is stormy, we can hear it roar. We are twenty miles from Coos Bay.

We lived on a farm on the Coquille River last year, and when it rained for a while the river rose, and our house, which was ten feet from the bank, was surrounded by water on Thanksgiving Day.

We took a row-boat and went across the fields and orchards to a neighbor's house. When the fences were out of sight, the water was over six feet in the fields.

I used to have two dogs. One was a big St. Bernard named Bruno. He weighed one hundred and thirty pounds, and was only a few months old. The other I called Dot, and she weighed two pounds and was two years old. Bruno used to haul me over the snow in a sled in Washington.

I will exchange postals with any of the cousins. Your cousin,

(Miss) CECIL HALL, Age Fifteen,  
Myrtle Point, Oregon.

DEAR COUSIN SALLY—  
I want to write and tell you that I think our page has been so interesting. I like the stories, and I love to read the letters. I hope our club will keep on growing. I like it very much and will do all I can to help, and I hope all the other cousins will help, too.  
MABEL BEEBE,  
R. R. 2, Box 37, Adrian, Michigan.

## The Violet

Dear little purple violet,  
Fairy of the spring;  
With your lovely fragrance,  
Oh! what joy you bring.

You have no cares, no sorrows,  
No studies and no tasks,  
Just budding, growing, blossoming,  
As long as springtime lasts.  
MABEL KELLEY, Age Twelve,  
R. F. D. 1, Monroe, Washington.

## The Roll of Honor

THE following boys and girls deserve honorable mention for the work entered in our late drawing contest:

- Bessie Hay, Dubuque, Iowa.
- Eloise Leitch, Spencer, Iowa.
- Margaret O. Cox, Fall Branch, Tennessee.
- Sylvia Murray, age fifteen, Auburn, Illinois.

- Marie Renn, age fourteen, Frederick, Maryland.
- Bayne Rutledge, age fourteen, Stanley, North Carolina.

- Elizabeth Grinstead, Morrisville, Missouri.
- Edna Janice McCoy, Rice, Washington.
- Lois M. Edwards, Roxabel, Ohio.
- Archibald Neill, Philadelphia, Pennsylvania.

- Paul R. Loomis, Salamanca, New York.
- George I. Austin, Lisbon, New Hampshire.
- Opal Slagle, Delta, Ohio.
- Susie Thompson, Quitman, Missouri.



Some cats should be tied up with strings. They're always falling out of swings, Or else they're bumping into things.

## Our Bulletin Board

The prize-winners in our May 10th drawing contest are:

- Cameras**—Clara Stackman, age sixteen, Bridgeport, Connecticut, and George Meredith, age fifteen, St. Louis, Missouri.
- Books**—William Sjoeslius, age fourteen, Duluth, Minnesota; Lois Stewart, age thirteen, Springfield, Ohio; Lillian C. M. Steers, age sixteen, Wantagh, Long Island; Frank C. Hout, age fourteen, Middlebury, Indiana.

Prizes for the six best colored pictures sent by boys and girls from six to eleven are awarded to: Mazie Bengston, age ten, Salem, Wyoming; Gladys May Houghton, age seven, Ethel, Washington; Marion Featherstone, age nine, Red Wing, Minnesota; Byron Miller, age seven, Clear Lake, South Dakota; Glenn Chess, age eight, Moore, Montana; Gladys Whitney, age seven, Riceville, Iowa.

Delmar Souder, age fourteen, R. F. D. 1, Germantown, Maryland, is secretary of a Cousin Sally branch club and is anxious to know if there are any more branch clubs in Maryland, and if so, Delmar would be delighted to hear from some of them.

Floyd Crigler, of Hebron, Boone County, Kentucky, is a member of a corn club and has been hard at work raising corn to enter in their prize contest. The one that raises the most corn on an acre of land or has the best ten ears of corn wins a prize.

Here's wishing Floyd all the luck in the world. Won't we feel proud if he carries off the trophy? \* \* \*

In Holtville, sunny California, there is a club of the busiest girls, who meet every week and sew for their dolls. Margaret Sharp, the secretary, writes that in a very little while they are going to start making their Christmas presents. What sensible little girls to take advantage of vacation-time and not let things go until the last minute! \* \* \*

Not to have missed a day at school for seven years is a pretty fine record, I think. This is just the record that Bessie Hudson, of Wayside, Illinois, has earned for herself. And this spring she was presented with a gold pin from the county superintendent for punctuality during the year. How does your record compare with Bessie's? \* \* \*

James Spray, of Elkmont, Alabama, is learning to play the guitar. I am pleased to see that so many of our members are interested in music. \* \* \*

Don't fail to see our next page. It will contain a delightful little animal story by Alice Jean Cleator. \* \* \*

Be sure to see our next Bulletin Board giving the names of the lucky boys and girls in our June 10th contest.

# Just for the Housewife

## Tested Recipes and Useful Hints Worth Knowing

**Cucumber conserve** varies somewhat from the familiar sweet pickle, although both are made from ripe, firm cucumbers. Pare and seed as soon as turned yellow, and cut in pieces two or more inches long and two inches across. Put in salt water overnight, drain, and prepare syrup of white sugar dissolved with vinegar instead of water. Cook in this an ounce of whole mixed spices, strain out and add the cucumber slices, which have been softly dried in a cloth. Cook gently until transparent; lift out the fruit and boil syrup to the consistency of molasses, then pour over the cucumbers in small jars.

**Green-watermelon preserve** is made from the white rinds of ripe melons, first parboiling in a quart of water containing one-half dozen peach-leaves and half a teaspoonful of saleratus. This insures a fine, green tint. Remove to a bath of cold alum water, soak for an hour, drain and rinse. Make syrup of a pound of sugar for each pound of fruit, juice of one lemon and half a dozen clean, fresh rose-geranium leaves. Boil up, then remove the leaves and put in the fruit, cooking until tender. Set aside for twenty-four hours, drain off syrup and cook down half, again add the fruit and finish cooking until transparent. Seal and keep in a dry place.

**Red-watermelon preserve** is not so well known, but is equally delicious. Remove seeds and white portion from firm, ripe melon, weigh and use half as much sugar as melon, with juice and grated rind of two lemons to every six pounds of melon. Put all together in kettle and boil slowly until as thick as desired. If preferred, this preserve may also be flavored with the rose-geranium leaves, but is very satisfactory without. **MAUDE E. S. HYMERS.**

**Good Recipes for Gingerbread**—You will find the following recipes reliable in every way, for they are the ones that met with favor in grandma's day:

**Old-Fashioned Molasses Cake**—One-and-one-half cupfuls of molasses, one tablespoonful of lard or butter, one egg (this can be omitted), one cupful of hot water, one teaspoonful of baking-soda, one of ginger and a small one of salt, and two-and-one-half cupfuls of flour, which should be added last. Let the molasses and butter boil gently a few minutes. Cool them, then add the ginger, salt, soda, the well-beaten egg, and mix in the flour. Bake in shallow pan in a quick oven.

**Ginger Snaps, No. 1**—One pint of molasses, one teaspoonful of ginger, one cupful of butter, one teaspoonful of soda. Let the ingredients boil and cool. Add flour enough to make a stiff dough. Roll it out quite thin on a floured board. Cut into cakes with a round biscuit-cutter and bake quickly. When cool, they should be placed in a stone jar and covered tightly. They will keep crisp for some time.

**Ginger Snaps, No. 2**—This is an old antebellum recipe. One cupful of molasses, one of sugar, one of butter, one tablespoonful of ground ginger, one teaspoonful of saleratus and one-half cupful of water. Make this stiff enough with flour to roll out. Cut into round or fancy shapes and bake in biscuit-pans in a brisk oven.

**Gingerbread**—In making this, one thing vital to its success is the thorough and prolonged beating before the dough is turned into the baking-pan. The ingredients are five eggs, one-half pound of brown sugar, one-half pound of fresh butter (or half lard can be used), one pint of molasses, one-and-one-half pounds of flour, four tablespoonfuls of ginger, one teaspoonful of allspice, the juice and grated peel of one lemon and one orange. Beat the eggs well. Mix the molasses, butter and sugar, and add the ginger. Pour the mixture and the eggs alternately into the mixing-bowl. Add the flour and beat one-half hour. **M. R. C.**

**Green-Currant Pie**—Line a plate with rich crust, put in one-and-one-half cupfuls of green currants, beat together three fourths of a cupful of sugar and one egg, and pour it over the currants, sprinkle with a pinch of salt, dot with bits of butter, cover with a top crust and bake.

**Cream Cheese**—Strain eight quarts of milk into a tub, leaving on all the cream. Heat two quarts or so of the milk, then add it to the cold, till the temperature of the whole is ninety-eight to one hundred degrees Fahrenheit. Add one-fourth teacupful of rennet, stirring well; if the curd does not form well in an hour, add more rennet. When the curd is formed, cut it into small squares all the way to the bottom, and break it gently with a skimmer, to let the whey separate. When the whey is separated, put the curd into a cheese-cloth straining-bag and hang over the tub to drain. Twist the bag, and put a heavy weight on it, to press out the whey thoroughly for ten minutes. Then again cut up the curd and press it again as formerly. Continue this until it is thoroughly drained, then press it all into some form or mold, and scald. To scald it, cut the curd into pieces about one fourth of an inch in size, put it into a strainer and immerse it in a kettle of warm water, enough to cover it. Then heat till the water is one hundred and five degrees, stir it well till the curd is warmed through (probably half an hour), then gradually add cold water till it is reduced to eighty-eight or ninety degrees. Drain the curd again thoroughly, and salt it, allowing four ounces of salt to ten pounds of

curd, and mixing well. Then put it into tubs or molds for two days. After this, remove it and grease it with butter; set it on a shelf in a dark, cool room; grease and turn it every day till firm. **Mrs. D. L.**

**Currant Cake**—Make a very delicate white layer-cake, using any good recipe. Sweeten a pint of red-currant juice and put on to boil. Add corn-starch wet up with a little cold juice, to make it of the consistency of jelly. Spread this between the layers of the cake and ice the top.

**Cherry Pudding**—Four thoroughly beaten eggs, one tablespoonful of soft butter, one pint of milk, a little salt and one pint of flour. Stir in one pint of pitted cherries, pour into a buttered baking-dish and bake for half an hour or until done. Serve hot with a sauce made of one cupful of butter, two cupfuls of sugar, the whites of two eggs, three tablespoonfuls of cherry-juice and one fourth of a cupful of hot water. Beat until smooth; place the bowl in a basin of hot water and stir until smooth and frothy.

**Remedy for Cabbage-Worms**—Mix together one quart of flour and two tablespoonfuls of soda; sift some into the plant in the morning when the dew is still on it.

**When washing summer fabrics**, these suggestions should be carefully followed if one does not wish the color to fade: When washing green, put a lump of alum in the water; blue, a handful of salt; brown, a little oxgall; tan, hay water, made by pouring boiling water over a handful of hay; red or pink, vinegar.

**A Splendid Scouring-Soap**—Melt two bars of any good laundry-soap together with one pint of fine sand, one fourth of a pound of good slaked lime and a package of baking-soda. This recipe makes a good soap for scouring floors, tables, tinware, etc. It will not injure the hands. Can be made and used as a soft soap or cooked long enough so that it can be made into bars.

**Plaster to Relieve Pain**—Melt together in a pan equal parts of beeswax and mutton-tallow. When cold, add a little winter-green-oil. Take a coarse piece of cloth and saturate it with the mixture, heating it again, and applying as hot as can be borne. It will quiet pain in a few minutes. The same cloth can be used again by redipping and reheating.

**To Get Rid of Moths**—I do not use anything for moths in carpets but gasoline. Put gasoline in a sewing-machine oil-can and give the edges of the carpet a good bath with it. Do not use the room for at least a day and a night afterward, and under no circumstances should a light of any kind be carried into the room. **E. O. S.**

**Sweet Hay for Barrel Cleansing**—There is a thrifty farmer's wife on a beautiful, big Pennsylvania farm, who has recently demonstrated a novel method of cleansing and sweetening the barrels that have held meat or brine through the winter, and are required for another season's use. On such big farms the pork-barrel is an important consideration, if the next year's supply of salt pork is to be kept sweet, untainted and wholesome for the frequent demands made upon it by numerous farm-hands, likewise the pickle-barrels, where great quantities of cucumber pickles are stored in brine. Various methods of cleaning and purifying these brine-soaked barrels are popular, but decidedly the simplest and the most effective plan was demonstrated by this ingenious housewife. After washing, scalding and rinsing in the usual manner, she filled the barrel about half full of sweet hay, poured boiling water upon it, covering each barrel closely and letting it stand until cold. There is no difficulty in keeping either meat or pickles in the old barrels thus renovated. **Mrs. P. W. H.**

**A tried and tested recipe for keeping butter fresh**: Boil together three gallons of water, one-half gallon of salt, two cupfuls of brown sugar, two tablespoonfuls of saltpeter. Boil three hours and, when cool, strain into a large stone jar. As the butter is made, wrap it in clean cloths, in one-pound packages. Sink butter into preparation by weights. Butter treated in this way will keep absolutely fresh, and retain its sweet flavor for twelve months. Try it and prove it. **Mrs. W. R.**

**To peel peaches quickly**, drop them into boiling water for a minute or two and then plunge them into ice water. The skins will slip off without further trouble.

Sliced peaches can be kept from turning brown by covering with cold water till ready for the table. Just before serving, throw off the water and prepare as desired.

**In making crab-apple jelly**, an ounce of ginger-root to a quart of juice makes a delicious flavor. Boil the ginger-root in the juice about twenty minutes before putting in the sugar.

**To bake peaches deliciously**, remove the skins and put them whole into a baking-dish with bits of butter and a little hot water. Bake until nearly tender enough, then sprinkle the tops with chopped nuts and a little sugar and bake long enough to brown nicely. Serve cold with cream.

**When a patient can be bolstered up in bed**, the spine sometimes becomes overheated by the pressure of the pillows. It will be found less heating if the lower pillows are arranged in the form of an inverted V, with the small of the back fitting into the V. Afterward other pillows can be placed upon these transversely, to support the shoulders and head,

**Clean Food**

It is an incentive to hunger to see Uneeda Biscuit made. All materials are of the finest quality—clean, nutritious. The dough is mixed in spotless trays in a spotless bakery. Rolled thin; baked in wonderful ovens scientifically heated to give just the right crispness; then packed into the moisture-proof packages that keep them fresh, crisp and clean till eaten.

Never sold in bulk

**5c**

In the moisture-proof package

**NATIONAL BISCUIT COMPANY**

**Cooling as an Icicle**

If you want to think of crisp winter weather and sparkling frost; if you want to forget the heat and the dust and the thirst for real, cool comfort

**DRINK Coca-Cola**

As sparkling, wholesome and refreshing as a spring house icicle. So next time you're hot or tired or thirsty, if you're anywhere near a place that sells Coca-Cola, go in and give yourself a real treat.

**DELICIOUS — REFRESHING THIRST-QUENCHING 5c Everywhere**

**THE COCA-COLA COMPANY**  
Atlanta, Ga.  
52

Whenever you see an Arrow think of Coca-Cola

Send for our interesting booklet, "The Truth About Coca-Cola"

It is to your advantage to mention Farm and Fireside in writing to advertisers. Farm and Fireside folks get the very best results.

**Thor**

**THE MOTORCYCLE FOR THE FARM**

Here's a means of transportation that will save you time and furnish an endless source of enjoyment. Think of riding five miles to town over the roughest roads in ten minutes! Why, you can do twice as much work with less effort if you own a Thor. Tell your friends to get a Thor and form parties for cross country trips. But be sure to tell them "THOR" for the Thor is the motorcycle with the free engine clutch, which enables you to stop while the motor keeps on running. The Thor won every endurance contest the last two seasons and stands alone as the fastest and most reliable motorcycle made. A handsome model await your approval. Four (4) Horse Power Single Cylinder, either Chain or Belt drive. Beautifully illustrated in

**BOOK SENT FREE ON REQUEST**

This book describes in detail the wonders of the Thor. Write for one today. It's FREE to you. Write now.

**AURORA AUTOMATIC MACHINERY COMPANY**  
Department 8. 1307 Michigan Avenue, Chicago, Illinois



WESTERN EDITION

37121

LIBRARY  
RECEIVED  
AUG 10 1911  
U. S. Department of Agriculture

# FARM AND FIRESIDE

THE NATIONAL FARM PAPER



ESTABLISHED  
1877

AUGUST 10  
1911



The Present Status of the Sheep Market—Page Seven

**Ann Arbor**  
**"THE BALER FOR BUSINESS"**

**BALES HAY FASTER**  
**SAVES TIME MONEY, LABOR**  
**GOOD MONEY EARNER**  
**GUARANTEED**

Not "Talking" Points But Working Points

Get the Ann Arbor printed matter and you will see that Ann Arbor presses are designed and built with the idea of greatest simplicity and efficiency. Observe that we give solid facts about the big capacity and low operating cost—points that are making hay press operators replace old style machines with the Ann Arbor.

**"OVER 45 STYLES AND SIZES"**

A press for every purpose, and for every section of the country. Strength, Durability, Capacity and Endurance are the points that will convince you that the Ann Arbor is your best buy. 25 years' success back of every press and a positive guarantee.

Write for Free Baler's Book and other printed matter  
**ANN ARBOR MACHINE CO.**  
 Box 408 Ann Arbor, Mich.

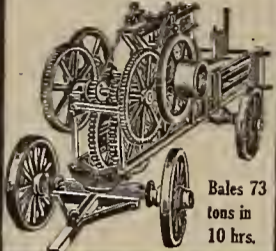

Bales 73 tons in 10 hrs.

**Accept this \$25 Suit**

Let us send our outfit at once with our new most remarkable easy money-making offer, with your extra sample suit offer too. Be well dressed, and backed by us in spare time or all time, as our representative in your exclusive territory. No money or experience necessary. No references or red tape. Your best chance is here if you write a postal quick. Our offer means

**\$5 Per day easy or \$30 to \$50 a week**

We trust you absolutely. Just show our Big Outfit of Samples and Color Plates of latest beautiful styles. Everything sent **Express Pre-paid**. Your friends will grab at this chance to get our perfect hand tailored made-to-measure swellest suits, pants or overcoats. They'll save \$3 to \$5. Suits \$8 to \$15. Biggest profit and confidential special inside wholesale prices to you. Fit, workmanship and material Guaranteed by Bond. Finest in America for style, looks and wear. Undersell all others. **SEND NO MONEY** No experience or capital needed. You want this sure. Don't miss it. We want you. We back one man this way to each territory. Get in quick. No risk. We help and show you. Chance of life to get best clothes, make most money. Keep it to yourself! Hurry postal today.

**Great Central Tailoring Co.** 777 Jackson Blvd. CHICAGO, ILL.



**The "Eli" King of Horse and Steam Power Balers**

A train of followers, but no equals. Proves its superiority wherever it goes. Makes tight shapely bales, not loose bundles, works fast, avoids accidents and endures. Little draft, tremendous power. The machine that makes competitors tremble. Eli catalogue free.

**Collins Plow Co., 1110 Hampshire St., Quincy, Ill.**



**THE LARGEST AND BEST LINE OF WELL DRILLING MACHINERY** in America. We have been making it for over 20 years. Do not buy until you see our new illustrated Catalogue No. 15. Send for it now. It is FREE.

**Austin Manufacturing Co., Chicago**

**WE SELL YOU AT WHOLESALE**  
 Agents' Price One AMERICAN Motorcycle or Bicycle

We give 30 Days' Free Trial and Prepay the Freight. Write for our introducing offer and catalog and say whether you want Motorcycle or Bicycle. Do it now.

**American Motorcycle Co., R506 American Bldg., Chicago**



**ADMIRAL 2-MAN PRESS**  
 3 FEEDS TO THE MOUTH SELF FEEDER CONDENSING PACKER

**ADMIRAL HAY PRESS CO.** KANSAS CITY MISSOURI



**GET A FARM HOME NOW**

We have farms for all, both great and small. In 21 States: from New York to North Dakota; from Michigan to Missouri. For free list of fine farms ask B. F. McBurney & Co., 708 Fisher Building, Chicago, Illinois.

**AUTO-FEDAN HAY PRESS**

Only successful self-feed. 2 men can operate it. 20% less expense to operate. Record run 3 tons in 1 hour.

**AUTO-FEDAN HAY PRESS COMPANY**  
 1507 W. 12th St., K. C., Mo.

BE AN ILLUSTRATOR—Learn to draw. We will teach you by mail how to draw for magazines and newspapers. Send for catalog.

School of Illustration  
 25 Page Bldg.  
 Chicago, Ill.

**Money-Making Farms**

throughout 15 states; great variety, size and price. Stock and tools included with many to settle estates quickly. Mammoth illustrated Catalogue No. 34 free. E. A. Strout, Station 3063, Old Colony Bldg., Chicago, Ill.

**A Good Position for You**

sure when you graduate from **GEM CITY BUSINESS COLLEGE** of Quincy, Ill. Thorough courses in Short-hand, Typewriting, Bookkeeping, Actual Business Practice, Penmanship and Mathematics. 23 competent teachers—1400 students annually. Our own \$100,000 specially equipped building. Write now for beautifully illustrated catalog and year book.

**E. L. Musselman, Pres.**  
 Lock Box 14, Quincy, Illinois



# With the Editor



HAVE a rather pathetically cheerful letter from a reader living near Okanogan, Washington. The odd thing about my letters is that the most cheerful are the most pathetic, sometimes. This brings to mind a picture something like this:

The writer is an oldish man sitting in a rude cabin on a homestead claim twenty miles from the railway. He is alone, for his wife is away "teaching a nine-months' term of school" and he is "baching it." And because I happen to have seen such landscapes, I can imagine the scene of wonderful beauty which lies about that lonely cabin.

In the first place, it is a clean, fresh, delightfully invigorating spot. My friend and his wife have regained their health there, in the few years of residence. There are great, dark masses of pine, tamarack and fir—much of it cut off and growing up again. And thousands of acres are covered with that poplar which denotes a cool, high climate—people from the East call it "quaking asp" and the name will do well enough, but it is not the old "quaking asp" of Canada or New York, or the little "popple" that was the nearest thing to a tree we had on the Iowa prairies.

And this homesteader wants me to tell him how to farm those lands profitably. I wish I could do it, but I can't. Nobody can. The problem must be worked out just as we worked it out in Nebraska and Dakota—by hard knocks.

The trees when cut down sprout up, and he asks what will cure that. I think I should try chopping into each tree with an ax, in the summer, so as to girdle it all around and leave a ruffle of bark and chips sticking out all around the tree—right at the bottom—and I'd fill that ruffle or groove with salt. This might kill the sprouts, and thus deaden the tree, root and branch. They say it will do it with our locusts—I'm going to try it this year—and it might work with those poplars. And it might not. If it did, I'd pull them out when dead with a stump-puller.

Now, someone will shout from the back benches that the poplars are as thick as the hair on a dog, and the salt cure is out of the question. Well, in that case, I would get some goats, and after cutting and burning the poplars, I would turn in the goats. They would keep down the sprouts, and do the business.



HIS friend lives at an altitude of from 3,000 to 5,000 feet above sea-level, and there are many late frosts in the spring, and early ones in the fall, and he says, "many times in the summer there comes a hard white frost and destroys all our fine crop of beans and everything else that is of a tender nature." He thinks that it would be a fine fruit country if they knew what varieties to set out. "The frost acts so curious," says he, "many times it will skip a row in the garden and freeze everything on each side down to the ground." The point is that a difference of a few hundred feet in elevation makes all the difference in the world in such a country, and every farm—even every field—is a law unto itself. It will take years of study and experiment to work out the problems with which those homesteaders are grappling so cheerfully and so bravely.

Thirty miles away are snow-capped ranges, and every night the coolness of the high peaks come down to bless and revive the weary and worn—but it plays whaley with beans and tender things. No corn there, as a safe crop, that's certain. One thinks of oats, rye, barley, turnips, rape, all the grasses, cabbage, truck-farms, and a developing dairy, hog and sheep industry. The slogan must be crops that frost won't hurt. But in some manner the problems will be solved. That great Northwest will some day be the home of a large population of hardy mountain farmers.



LETTER comes in from a correspondent in Colorado, Florence L. Clark. It may give our other mountain friend a hint.

The queerest and prettiest agricultural landscape one can find in many a day greets the traveler at Buena Vista, Colorado. There, on a plateau 8,000 feet high, up among the tall pines at the very foot of the Collegiate Range, where Mounts Princeton, Harvard and Yale tower side by side 14,000 feet, grow the finest field-peas in the country. They bring four cents a pound.

A long mesa six miles wide stretches from the town back to the foot of the mountains. In July it is one great, beautiful stretch of exquisite vari-colored peablossoms. Backed by snow-topped mountains, it is amazingly beautiful. Creeks of sparkling ice-water, full of trout, tumble down from the mountains and splash through the mesa, affording free and abundant irrigation. The soil is as stony as a New England farm, yet those very rocks serve as an aid in the distribution of water. In the beginning the homesteaders at Buena Vista attempted to raise barley, oats and the hardier wheats on the mesa, but it was not until that farmer came along who sowed a field to Canada peas that prosperity really dawned and the agriculturist learned what Nature had made the Buena Vista mesa for.

Since the day of that first planting of field-peas, which resulted in a crop of fifty bushels to the acre, sixty pounds to the bushel, of peas fully twenty-five per cent larger than ordinary field-peas, the culture of this forage plant has spread rapidly, until now it is practically the only crop grown in the region. Hundreds of acres are given over to their culture, and large quantities are shipped away. One hundred dollars an acre is no uncommon return for the peas from an acre. Added to this income must be the returns from the sale of the hogs and sheep which are fattened on the fields after harvest.

The peas are sown as early as March and harvested in August. At that altitude snowfall is not uncommon as late as July. The peas, however, seem to grow only the more sturdy through the chilly nights and the sudden drops in temperature, so splendidly is the soil adapted to their growth. Wheat is sown with the peas to serve as a prop to the vines. Thus supported, they grow to a height of four feet. The sowing of wheat with the peas accomplishes a twofold purpose. The cutting of the peas is thereby made easier, and when the crop is used for feed, the mixture of the two forms of fodder makes a first-class balance of rations for stock.

Maybe this is the answer to our friend "thirty miles from Okanogan." Maybe it is the answer to many a mountain homesteader. If Canada field-peas are a paying crop at 8,000 feet in the air in Colorado, why not at 5,000 in Washington? Certain it is that there's some answer. And the fine thing about it is that, in working it out, the farmer is surrounded by Nature's choicest beauties. I have written a long letter to my friend in Washington, telling him what I should do and urging him to consult his experiment station. That's good advice to farmers everywhere, anyhow. The men of the experiment stations may know just the thing you want to find out. It's their business to investigate and make experiments. But it will be a long time before they will have worked out the problems of those mountain parks, mesas and benches. A spotted country is the hardest to understand—and any country is hard enough. I wish I understood my own farm.

*Hubert Quiek*

**Index to Advertisements**

CLASSIFICATIONS	PAGE
<i>Agents Wanted</i>	
Farson & Son.....	6
<i>Carriages and Accessories</i>	
Century Manufacturing Company.....	12
Electric Wheel Company.....	7
Harvey Spring Company.....	12
<i>Clothing and Boots</i>	
Eddystone Manufacturing Company.....	17
Great Central Tailoring Company.....	2
Steel Shoe Company.....	10
Woonsocket Rubber Company.....	11
<i>Correspondence and General Schools</i>	
Gem City Business College.....	2
National Salesmen's Training Association	12
Page Davis School.....	12
School of Illustration.....	2
<i>Farm Tools and Implements</i>	
Champion Potato Machinery Company... 10	
Collins Plow Company.....	2
Dick Manufacturing Company, Jos.....	11
New Process Manufacturing Company... 10	
<i>Fertilizers</i>	
German Kali Works.....	10
<i>Fences and Fencing Materials</i>	
Bond Steel Post Company.....	12
Pittsburgh Steel Company.....	9
<i>Foodstuffs</i>	
National Biscuit Company.....	20
<i>Hair Goods</i>	
Ayers, Anna.....	15
Parker's Hair Balsam.....	15
<i>Hay-Presses</i>	
Admiral Hay-Press.....	2
Ann Arbor Machine Company.....	2
Auto-Fedan Hay-Press.....	2
Dain Manufacturing Company.....	11
Ertel Company, George.....	9
Kansas City Hay-Press.....	11
Spencer, J. A.....	9
<i>Household Miscellaneous</i>	
Hazel Atlas Glass Company.....	15
Hoosier Stove Company.....	15
Kirk & Company, James S.....	17
Schmoller & Mueller Piano Company... 16	
Somers, Harold.....	15
<i>Land</i>	
McBurney Company, B. F.....	2
Sacramento Valley Development Ass'n... 12	
Strout, E. A.....	2
<i>Live Stock, Stock Foods and Remedies</i>	
McKallor Drug Company.....	7
<i>Paints</i>	
National Lead Company.....	12
<i>Patents</i>	
Coleman, Watson E.....	12
Farnham & Sues.....	12
<i>Powder, Dynamite, Etc.</i>	
E. I. Dupont Powder Company.....	9
<i>Publications</i>	
Woman's Home Companion.....	8
<i>Roofing</i>	
Barber Asphalt Paving Company.....	10
Century Manufacturing Company.....	6
Edwards Manufacturing Company.....	6
<i>Separators</i>	
American Separator Company.....	7
Sharples Separator Company.....	7
<i>Sporting Goods</i>	
American Motor Cycle Company.....	2
Eastman Kodak Company.....	20
Harley Davidson Motor Company.....	12
Mead Cycle Company.....	12
<i>Telephone Apparatus</i>	
American Telephone and Telegraph Co.. 12	
Western Electric Company.....	11
<i>Well-Drilling Machines</i>	
Austin Manufacturing Company.....	2

## ABOUT ADVERTISING

FARM AND FIRESIDE does not print advertisements generally known as "readers" in its editorial or news columns.

Mention FARM AND FIRESIDE when you write to our advertisers, and we guarantee you fair and square treatment. Of course we do not undertake to adjust petty differences between subscribers and honest advertisers, but if any advertiser in this paper should defraud a subscriber, we stand ready to make good the loss incurred, provided we are notified within thirty days after the transaction.

FARM AND FIRESIDE is published on the 10th and 25th of each month. Copy for advertisements should be received twenty-five days in advance of publication date. \$2.00 per agate line for both editions; \$1.00 per agate line for the eastern or western edition singly. Eight words to the line, fourteen lines to the inch. Width of columns 2 1/4 inches, length of columns two hundred lines. 5% discount for cash with order. Three lines is smallest space accepted.

# FARM AND FIRESIDE



PUBLISHED BY  
THE CROWELL PUBLISHING COMPANY  
SPRINGFIELD, OHIO

Branch Offices: 381 Fourth Avenue, New York City; Tribune Building, Chicago, Illinois  
Copyright, 1911, by The Crowell Publishing Company  
Entered at the Post-Office at Springfield, Ohio, as Second-Class Mail Matter

## A BLUE MARK

In the square below indicates that you are an old subscriber and that your subscription expires this month. Renew by accepting one of our offers before they are withdrawn.



## SUBSCRIPTION PRICE

One Year (24 numbers) 50 cents  
Canadian, 1 Year . . . 75 cents

Subscriptions and all editorial letters should be sent to the offices at Springfield, Ohio, and letters for the Editor should be marked "Editor."

Silver, when sent through the mails, should be carefully wrapped in cloth or strong paper so as not to wear a hole through the envelope.

Vol. XXXIV. No. 21

Springfield, Ohio, August 10, 1911

PUBLISHED  
SEMI-MONTHLY

Laziness is not half so bad as giving up to it.

If the rain did not fall upon both the just and the unjust, would you get any?

## The Question of Sugar

WHETHER Henry O. Havemeyer robbed the nation through the Sugar Trust or not, whether he stole from his business associates or not, whether he corrupted the Congress of the United States or not, may be interesting, but it is not now important. Havemeyer is dead. Permit us to suggest to this present Congress that the question of sugar for the people is alive.

Almost everything produced for human food reaches the table, where it is consumed, combined with sugar. Sugar is, perhaps, the greatest single article of human food. For the benefit of the Sugar Trust we have a color test in our tariff law which makes it impossible to bring in clean sugar and sell it. The law so reads that the light-colored, unrefined sugars, which are splendid, clean sugars for the cannery, the kitchen and the factory, cannot be imported and sold. It is as if the law said, "No sugar shall be imported unless in so impure a state that it will have to be worked over at the refineries of the Sugar Trust and its associates."

This is iniquitous. With the "Dutch standard" color test eliminated, even under the present tariff law, good, clean, unrefined sugar, as pure as most of the white sugar sold, but colored a very light brown by the molasses that the centrifugal machine will not quite take out, would come into this country and compete with the trust sugar. It would give the housewife something she needs—a good, pure sugar for culinary purposes, at a lower price. Here is a way to reduce the cost of living, without hurting any legitimate industry. For the beet-sugar factories—most of which are owned or controlled by the Sugar Trust—produce refined sugar, which would still be protected by a duty of \$1.95 a hundred pounds, which ought to be ample. Here is something for the women to think over.

## Save the Corn-Fodder

THE hay-crop will be short this year—that is certain. And not for a long time have so many reports come in of a shortage in oats and barley. The oats-crop in South Dakota is reported almost a failure; it will be far lighter than usual and smaller in area in Ohio, Indiana, Illinois and Iowa; light in Illinois; far below the average in Missouri and Kansas. Meadows and pastures are in bad condition and the hay crop runs from complete failure to light from the Rockies to the Atlantic, and from Minnesota to Arkansas. This must mean scarce and dear feed all over the land.

It is too late now to take our advice and sow a catch crop for supplementary feed, but the annual waste of corn-fodder may be avoided. Last winter we fed our farm horses on corn-fodder from September till the last of April with the best of results. Corn-fodder is not really inferior to hay for horses, cattle or sheep during this period. And all over the corn-belt men with no silos will wonder where they are to get feed, or will fail to market a profitable crop, while letting the stalks dry up in the field. This is a good year in which to invest in a binder or some other machine for cheaply cutting the corn. It is likely to pay for itself this season. Unless all signs fail, feed must be scarce and high.

But the same heat and drought that have shortened the oats, barley and hay have stored the best elements of food in the stalks of the corn. But it has not been stored for any farmer except the one who saves it.

## Our Friend the Sorrel

THAT yellowish-brown weed growing up in patches in mid-western pastures and meadows is sorrel. It has come in with the aging of the farms. None of it was seen a quarter of a century ago. It has been called a bad weed, but it is a good one, for it tells of something wrong in the soil. That something wrong is sourness. Sorrel comes as clover and alfalfa go. Lime in some of its forms is needed where sorrel grows and the legumes fail, and the sorrel is the alarm-clock that tells the farmer when to wake up.

P. S.—Don't confuse this with the pretty oxalis that grew wild on the prairies in the old days, and which is sometimes called sorrel. We mean by "sorrel" that weed rather new to the West, that looks at a distance very much like a patch of burnt grass in the pasture.

Some retired farmers actually work their brains harder playing cards and checkers than they ever did at farming.

At Clarinda, Iowa, there will be a Chautauqua in August, and, as an auxiliary, a camp for farm boys and one for farm girls. All the results of "a different kind of rural schools." And, incidentally, there will be a good-roads campaign in Page County operated by the schools. Different? Well, somewhat!

## About the Markets

IN THE last number of FARM AND FIRESIDE appeared the first of Professor Taylor's articles on the marketing of hogs and corn. In this issue is the second article. There is likewise in this issue a letter on the sheep-market by Mr. J. P. Ross, who is an authority on the production and sale of sheep.

The call for such information as this has been strong and is due to the readjustment of our common ideas on agricultural subjects. The United States has been enlarging, new agricultural lands have been opened and central markets have become great factors in molding ideas about the farm. For only a short time, however, have farmers believed that to study how to sell products off the farm is as important as to study how to raise crops and live stock on the farm. Much money has been lost—better say has not been made—because the farmer has not known his market.

Because of this demand from our readers, FARM AND FIRESIDE has arranged for market letters regularly by men who know what they are saying. All phases of the live-stock situation will be considered, each by a specialist. If there is any topic you would like to read about, write to us and say so; and if some part of the reports appeal to you more than other parts do, we would like to know it.

## Disk the Stubble

THE man who has stubble ground which he expects to fall-plow should disk it as soon as the crop is removed. Disking means more moisture. Moisture makes plowing easier. The disked surface falls into a more compact furrow-slice and makes conditions better for the soil-moisture to come up from below. Disking kills many weeds, which are maturing seeds by the million every day. Disking saves this year's moisture for next year's crop. It is a part of the gospel of dry farming, but it is as good for the East as the West. Save the moisture. Kill the weeds. Make plowing easy. Get the ground into condition. Unless you have a crop of clover or grass coming in it, or a pasture crop of rape, disk the stubble. It will pay.

After we had said this for the last issue, it was found that the paper had gone to press. Such advice should have been given long before this, at least in most sections where FARM AND FIRESIDE visits. But we sometimes learn the most when the bee is actually stinging us. And so the statements are given now for what they are worth.

There are acres upon acres of land in the United States which ought to be fall-plowed. But no disk follows the binder, and so the ground soon gets too hard to plow. Perhaps the spring is not favorable, the ground is plowed late, and a poor seed-bed results in a poor crop. And even if the farmer plans to spring-plow, a disk following the cutting of the grain puts the soil in a splendid condition for working, while negligence may mean that plowing will be entirely unsatisfactory. There probably are sections where the disk even yet would be of immense benefit to the coming crops.

## Better Churches

IN JULY, at Madison, Wisconsin, there met a notable conference for the consideration of the status of the country church, and how to make it better. The discussions were earnest and thoughtful. In June, at Ames, Iowa, there was a conference on country life at which the problems of social betterment were studied. Rev. M. B. McNutt, of Plainfield, Illinois, was at Ames, and told the inspiring story with which our readers are acquainted, of a successful country church. Mr. Chas. S. Adams, of Bement, told of the one thousand six hundred country churches which have died in Illinois in the last ten years, and the one thousand more which are ready to die. It is one of the most hopeful of signs that people are beginning to learn that a poor copy of a city church is as much of a failure in the country as a poor copy of a city school. What is needed is something different. And what's more, something different is going to be had.

Anyone desiring to make a study of the parcels post in connection with the express situation will do well to write to Hon. David J. Lewis, M. C., of Maryland, for a copy of his very notable speech delivered June 8, 1911. Mr. Lewis is a new member. He has introduced a bill calling for the purchase of the plants of the express companies by the government, and their use as a portion of the government plant of a postal express system—which is another term for a complete parcels post. Mr. Lewis is a student. He is one of the most able and promising of the new members.

If difficulties trip you up, fall across them, and get up on the other side.

Don't be too hard on yourself; one comes to hate a hard master after a while.

Salzburg, Johann-Wolfstrasse 1, Austria, June 27, 1911.  
MR. HERBERT QUICK, Editor,  
FARM AND FIRESIDE,  
Springfield, Ohio.

DEAR SIR: In your issue of May 25th, in the article "With the Editor," I read about the possible parcels post. The following quotation, to one living in Austria, seems ludicrous: "Any local parcels post will be a failure unless it is good for fifty miles from the originating post-office, or if it provides for a rate of more than twenty-five cents for an eleven-pound package." From this standpoint, the American people might as well be fleeced still by the express companies, that could not exist in Europe. Here one can send fifty kilos (equal to one hundred and twenty pounds) and distance limit is that of the Empire. For seventy-two hellers (seventy-five hellers equal five cents) one can send five kilos (one kilo equals two-and-one-fifth pounds) to any part of the Empire. I know no limit to the size of the packages. We recently sent a bouquet to Vienna. The box was four feet square and sixteen inches high. I saw a bunch of young trees being delivered. At the roots they must have been at least one yard in circumference and twenty feet long. In Belgium they can send one hundred and thirty pounds. So you see the European people have something from their parcels post.

Respectfully yours,  
DR. W. A. VAN NORDEN.

# The Tea Cure for Insurgency

By Charles Barnette Wolf

How many of you, I wonder, have written your congressmen or senators about some public question on which a vote will be due when they can't put it off any longer? And I wonder how many of you have received one of those soul-satisfying answers that say that the Honorable Something-or-other who holds his job by the votes or the carelessness of you and your kind—just common folks, you know—one of those satisfying answers that says that he hasn't made up his mind, but when he gets good and ready he'll "give it the most serious consideration?" Great little answer, that, to an inquiring constituent! Perhaps you wrote him that you would like parcels post so as to have the same chance to do business that farmers in

United States Senate,

WASHINGTON, D.C.

June 14, 1911.

Mr. F. O. Williams,  
Dundee, N. Y.

Dear Sir:—

I am directed by Senator O'Gorman to acknowledge your letter of June 12th, and to state that the matter referred to will receive careful attention.

Respectfully,

*Francis V. S. [Signature]*  
Secretary.

"One of those satisfying answers"

other civilized nations have—and he answered that he'd "Give it his most serious consideration." And did you think it a sort of cold handout? Well, I won't say what I think—but it reminds me of the better way, the more sociable and polite way, in which they handle disgruntled farmers in Canada. Over there they give 'em the Tea Cure for Insurgency. When we get this reciprocity going full force, maybe they'll introduce the Tea Cure with other Canadian products.

\* \* \*



mellow racket of a flicker drilling the steeple of a country church? It had a snout like a razorback shoat and weighed like a Mormon elder's sins. You always burned yourself filling it, and said things you learned from the hired man. But you forgave it in the evening, when it sang of how it came down through seven generations of your folks and had a brother that suggested locomotives and an uncle that took an inquisitive Irishman a mile out to sea when he held it over the cannon's mouth to shut in the roar.

That old kettle was always sputtering about something, for granny had as lief lost her soul or misplaced her specs as have it boil dry and crack off the lime inside that made it sweet. What would she have thought if that old kettle had slid off its crane into politics? What granny knew of politics wouldn't prime a modern phonograph. But times have changed. The grannies run for office now and teakettles slither about in economics and statecraft like a drunken sailor in a storm-swept banana-grove.

Look at Canada! Never mind mounting a telescope on the corn-crib, but read this eight-months-old item of news:

A thousand farmers from western Canada recently marched to Ottawa to petition the government for tariff revision, direct taxation, shorter bank charters, lower freight rates, reimbursement for stock killed, cooperative laws, chilled-meat plants, a Hudson Bay railroad, terminal elevators, free trade on implements, lumber, cement, fish, etc. They were heard by Governor - General Earl Grey and Premier Sir Wilfrid Laurier and the parliament. The premier spoke briefly and unfavorably on tariff revision and terminal elevators and the Hudson Bay railroad—ignoring the rest. The farmers took tea with Countess Grey.

And so a thousand farmers traveled two million miles and spent a hundred thousand dollars, to get some laws (not parcels post, but the principle's the same),

"Tea doth our fancy aid—repress those vapors which the head invade—and keeps that palace of the soul serene"



and were steered up against a tea-party by a handful of statesmen and sent home "lawless" as they came. Sir Alfred Austin, the poet laureate, or someone, has written the following charming little poem to commemorate the event:

Oh, for scaling tariffs downward  
They did most humbly pray,  
But the prayer clerk was washing cups—  
They took tea with Countess Grey!

They couldn't float free lumber,  
Their free fish got away,  
The premier passed the napkins—  
They took tea with Countess Grey!

The gloom that fell on chilled-meat plants  
Would have stalled a four-horse dray,  
So everybody passed the meat—  
And took tea with Countess Grey!

Correcting elevator graft,  
They learned with sad dismay,  
Is out of style this season—  
They took tea with Countess Grey!

For their live stock killed by railroads,  
The farmers wanted pay,  
But instead each got a wafer—  
And took tea with Countess Grey!

Laws for coöperation  
They got the same old way,  
With one grand and united swig—  
They took tea with Countess Grey!

Go to! Ye "lawless" pioneers!  
Go with the blizzard play!  
Subdue the wilderness with this—  
"We took tea with Countess Grey!"

'Twill make a bully epitaph,  
When you've slaved your lives away,  
And eke your progeny may boast—  
"Dad took tea with Countess Grey!"

When our old friend Gideon armed his hosts with pitchers and lamps some years ago, and chased the Midianites to the woods, it was considered quite a stunt and everybody hollered "Hurrah for Gideon." To-day, when a handful of statesmen, armed with cups of tea, brave a thousand farmers and vanquish them, we sit around hollerless as a deaf-and-dumb man's tomb. Is not the teacup a much less deadly weapon than the water-pitcher and the hanging lamp, and the feat, therefore, more notable? Shall we deny these statesmen the fame to which they are entitled for the greatness of that feat? Could not the same scheme be used successfully in the United States if the farmers get too rambunctious about parcels post or reciprocity?

Mark you—these were no kid-gloved, highly-manicured farmers, but hardy pioneers from lands where blizzards romp with the mercury till it goes away down and hangs onto the tail end of Professor Fahrenheit's name with both hands to keep from falling off his famous thermometer—lands so cold that a mere picture of them on a post-card leaves a streak of frost along a mail route and we have to have a tariff on works of art to protect ourselves.

Yet there stood the parliament and doughty earl and valiant knight—flanked by the countess to the right and to the left—pale but resolute. On come the farmers in motley array, till the whites of their eyes are visible. "Drink!" comes the stern command of the doughty earl. "Drink!" vociferates the valiant knight. "Drink!" echoes the countess on either flank. The farmers are staggered. They run up a red bandanna flag of truce. They parley and ask for terms. They are told to return home in peace and their invasion will be forgotten. They fall to and drink and drink and drink and sweat and sweat and sweat. The steam of battle lifts. The day is won. The capital is saved. Verily, one would think that the Senate would act in the direction of reimporting some of the oil and steel countesses exported by us in years gone by.

Some folks think this idea of bearding the farmer with teacups when his spirits are ruffled and soaking the ruffles in tea, was inspired by the implement and lumber trusts, which yearn to swap the farmer machinery wherewith to work his land, or lumber to build a hen-house, and take the land as payment, while the farmless farmer wears his new hen-house for a watch-charm and runs his machinery up and down the road—or by the railroad trust, which hankers to fix things so that, when it hauls the farmer's live stock to market, it will get the proceeds and he will get the accidents.

The premier assures me such is not the case. He told me confidentially the other day that it was inspired by the following verse, which he found in a book of Chinese poetry that he used to read to parliament on rainy days when the golf-links were muddy:

Tea doth our fancy aid—repress  
Those vapors which the head invade—  
And keeps that palace of the soul serene.

The premier figures that the western farmer's head has been invaded by the vapors of desire for modern conveniences till his fancy is caked and needs soaking in tea, so he can revert to the simple life and enjoy the musical swish of the ancient cradle and the hickory flail with which his forefathers garnered the golden



"The great Canadian remedy for farmer complaints"

grain—and a winter's supply of lumbago—every fall. Parliament hopes to inoculate the prairie provinces with China's tea-soaked serenity and holy rat-fed calm till the farmer's head becomes a serene palace of the soul—and the government has nothing to do but play hockey and drink frappé. Only one member of parliament is opposed to soaking the farmer in tea. He is a brewer.

The premier is very eloquent, and when he starts in to talk on China, you just stand there spellbound, with your elbow on the cigar-case, till your ginger ale grows stale. When he pushes his hat back, and puts one arm around your neck, and pulls his coat sleeve up about half way on the other one, and waves his cigar stump, you see visions of flowery lands where tea-soaked contentment has rested like a mongrel dog in the vestry of a church ever since the pup historian began to chase his tale. Folks float before you with serene soul palaces instead of heads and no apparent desire for new-fangled implements that feed the pigtail to unsympathetic cogs and tear the flowing shirt, which basks in heaven's sunshine free as air. You see the rural populace disguised as freight-trains, toting produce to the mart, and the government playing marbles while the human box car makes its own freight rates. You see man playing horse and prancing picturesquely through the scenery to the gay jinrikisha with the glad-eyed tourist on the box. And then somebody wants to look into the cigar-case and you have to move.

Under the inspiration of the above-mentioned visions, we take our place beside the teacup-bulwarked statesmen of the north, resolved to hoist their feat to a niche in the eternal rocks of standard literature. Back to your caves, ye ages of bronze and copper and bone and stone and iron, while we rise from the ashes of the past like the fabled Phoenix hen, whose nest went up in smoke when mythologic prairie fires swept over ancient plains, and soar aloft as herald of the dawn of tea—a dawn of which Longfellow well might sing, in the measure of his famous poem on excelsior:

The shades of night were  
falling fast  
As through the frontier  
hamlets passed  
A thousand farmers home-  
ward bound  
Who with this shout made  
echoes sound  
"Hurrah for tea! The  
great  
Canadian remedy for  
farmer complaints!"

Considering the relative inspiration of tea and excelsior, Longfellow might have done even much better than that in his prime of life.

Some reports say the farmer didn't hurrah, but a herald—soaring into the collar like a runaway army mule dragging a cannon through a swamp, resolved to hoist or burst a hame—can't stop for reports. The farmers should have hurrahd whether they did or not. It's the farmer's business to hurrah when the government pulls off a stunt—or doesn't—and any farmer who comes home from a grand meeting like that, with his digestive economy full of tea and a mental photo of a countess to cheer his after life, and then stands around hurrahless—like the fabled son who asked a fish and got a snake, and was handed a brick instead of a loaf—is mighty hard to please.

Still, we should not judge him harshly. He's not sore at being soaked with tea when he asks for something else. He's used to that in Canada, the same as here. But the straight brand and the trough system have queered him. Heretofore he has had a blend of campaign cigars and political harangues and free seeds and government documents and infant industries and congressional investigations and subsidized courts and fake prosecutions and railroad commissions and conservation. It has been eased into him gradually and he has always hurrahd. In fact, he has been one of our very best little hurrahers. But now—when he is asked to line up at the governmental tea-trough with a boiled shirt on, to sample a straight brand and sweat the ambitions out of his bosom in one grand spectacular debauch, he hardly knows whether he ought to hurrah or not. [CONCLUDED ON PAGE 7]



"Our statesmen must be particularly careful or farmers will all do that at once some day"

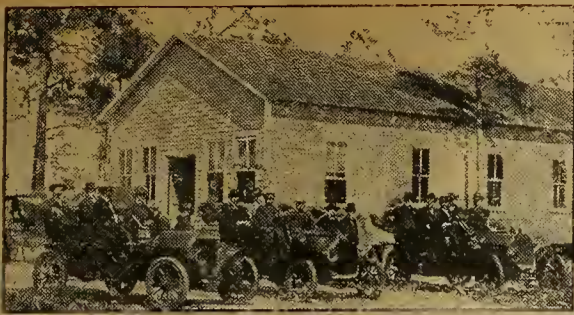

## Our Homeseekers' Excursions



### V.—Some Novel Facts About Florida—By Frank L. Barber



An assistant

AS THE United States is being flooded with literature booming Florida as a place of residence and of valuable agricultural lands, perhaps a few facts concerning that section of the country would be welcomed by the public. The writer spent one-and-one-half years in that state making investigations of the climate, the soil, the healthfulness of the surroundings and the general conditions. To begin with, I found that Florida

has several advantages over the North. Its winter weather is a compliment to the country, and yet that compliment is often a chilly one, for the nights, even as far south as Miami, Florida, are cool even to discomfort.

The winter of 1909-1910 was very cold for Florida, and much of the orange-crop was frozen. People wore overcoats during the evening and heavy clothing was for sale at all clothing-stores. On December 30, 1909, according to the United States Weather Bureau, the temperature fell to twelve below freezing at Jacksonville and ten below at Tampa, Florida. These are interesting facts to notice in the study of the state. The average temperature for Tampa, Florida, in July, is about eighty degrees, the cool nights bringing down the average considerably. New York City in July averages seventy-four degrees. Los Angeles and San Diego, California, average only sixty-seven degrees for July. The coldest-recorded temperature for Tampa is nineteen above zero, and for Pensacola seven above zero. However, there is no part of the Florida mainland below the frost line. The coldest-recorded temperatures of Los Angeles and San Diego are twenty-eight degrees and thirty-two degrees respectively.

In Florida, the rainfall in the summer is plentiful, in fact, it rains about every afternoon for a short time, and fierce hail-storms sometimes beat down vegetation. The wind at times is terrific and does much damage. Sometimes a rainfall of four or five inches will fall in a couple of hours, and the whole country appears like a lake, until the water disappears in the sandy soil. People who plant gardens on nice knolls for this reason generally have them washed out. The pine trees of Florida furnish little shade on account of their foliage or pine-needle bunches being so far above the ground. The whole state is covered over mostly with tall, scraggly pine trees.

In regard to general health conditions, a few cities show a comparatively small death rate, yet, in order to draw a complete and fair conclusion as to the healthfulness of Florida, the prevalence of

malaria should be taken into consideration. This disease occurs in all parts of the state with the exception of Key West. Malaria is not classed among the fatal diseases and does not materially increase the death rate, yet a person might almost as well be dead as to be afflicted with it. This disease is prevalent chiefly in the spring and summer months and so does not trouble tourists in the winter. I would estimate from investigations I have made that nearly ninety per cent. of the residents of Florida have malarial poison in their systems. In fairness, however, to Florida and to the South in general, I will state that other diseases and fevers are no more prevalent there than in the Northern States.

The land surface of Florida is very low for the most part and the portions of the state I visited reminded me of a huge sand-bar. There is a ridge or high knoll running north and south, close to the St. John's River; its highest point, known as Mossyhead, being 274 feet above sea-level. This is considered the most fertile land and also the portions best adapted for residence. The rest of the state is only slightly above the level of the sea, and is dotted with small lakes, swamps and marshes, not including the "Everglades." The character of the soil in general is sandy. From Pensacola to Jacksonville little but yellow or brown sand is to be seen. From Jacksonville south to Sanford, and thence on to Miami, the color of the sand is a gray-white. On the east and west coasts it is pure white.

Nearly all of Florida soils are deficient in humus or vegetable matter, and most all crops require fertilizers. When the latter are used, the yields are fair, yet hardly up to the harvest of Northern farms. As the soil is sandy, it has a tendency to drift, which



Dilapidated farms are found everywhere—Florida has her share of them



Grape-fruit is distinctly a southern crop. Large returns come from it

presents rather a serious problem.

The swamps and morasses of the State of Florida total more than 20,000,000 acres, altogether one fourth of the area of all the swamps in the United States, or it would cover a surface the size of the State of South Carolina. There are no cellars under dwellings in this state or in lower Alabama, the houses being built on rests laid on top of the ground. I was informed that cellars under houses spread or bring on malaria, on account of their dampness.

Still, I do not wish to maintain that Florida is uninhabitable, for there are many progressive cities and towns throughout the state. But the conditions in the city are somewhat different from those in the farming districts.

A person understanding Florida methods of farming may make a fair living or even a great success if he is energetic and resourceful, yet I believe his chances are far better in Ohio, in New York or in other Northern States. There are many abandoned farms and dilapidated buildings throughout the state of Florida as testimony of the too enthusiastic ideas of people who went there with plenty of money and roseate dreams, and bought farms before making a thorough investigation of the lands they were entering.

Florida may be a paradise for snakes and land companies, and its climatic advantages in the winter may be many, but these are offset by the various hot-weather pests which make life at least uncomfortable to the person not accustomed to them. Such snakes as the water-moccasin and diamond-back rattler are common, though they do not invade the cities. The fields are alive with sand-fleas, and these insects trouble mankind as much as do the mosquitoes. Another insect called the red bug, too small to be seen by the naked eye, makes its presence known

by burrowing into the flesh, causing intense itching and eruptions. This insect is common in all the Southern States. While the fishing in Florida is excellent, hunting is on the decline, since the best hunting is now limited to dangerous lands infested with reptiles. Acclimation in Florida, then, means that a person must become hardened to the bites and stings of Florida's insect life, as well as accustomed to its sub-tropical climate and all that that carries with it.

Then a person must become acclimated to the money interests of the country. That is sometimes a costly experience. It is almost impossible to learn the facts regarding the country without a visit to the place. If no visit is made, the acclimatization may not be pleasant. I have positive proof that certain Florida boards of trade are stockholders in Florida land companies. Also, that editors of the newspapers are officers of boards of trade. So you can readily see how impossible it is for a prospective settler in Florida to get a fair description of that state by writing to the boards of trade. I myself have been offered positions by certain Florida land companies to keep quiet, or, if I talked of the state, to boost the sunny side. But I believe it is best in this case, as in others, to mention the facts and let them tell the story whether it is a pleasant one or not.

EDITOR'S NOTE—Every country has its drawbacks. Mr. Barber has presented those of Florida. He speaks from first-hand information. It is an easy matter in this day of intense commercialism to learn of the glowing features of any farming section, but to get facts unbiased by the dollar-sign seems difficult. In the above description much that is good about Florida is omitted, for those facts are quite generally known.

However, it might be well to give the very consistent statement of Florida conditions made in 1907 by C. M. Conner, in Bailey's Cyclopedia of American Agriculture:

Agriculture, as it is understood in the North, exists only in its infancy in Florida. The farming is various, as the state contains the only really tropical area in the United States, and many special crops are grown throughout most of the peninsula. Cotton-planting is confined to the northern, or continental, part. In the older sections of the state, on the red hills, we find the same type of farming as is found in Georgia and other cotton-growing sections, but in the central and southern parts the farms are small and confined to growing small quantities of sugar-cane, sweet potatoes, corn and other general farm crops. Some truck is grown for the Northern market, but this is confined mostly to the richer moist lands. The extensive range has furnished pasture for large numbers of cattle, but this is becoming more and more restricted each year. Some livestock farms have been started during the last few years and are meeting with success. The rainfall is not very evenly distributed, the greater part of the rain falling in June, July and August. No protracted droughts occur, however.



Where consistent, intelligent effort has been put forth, up-to-date farms can be seen

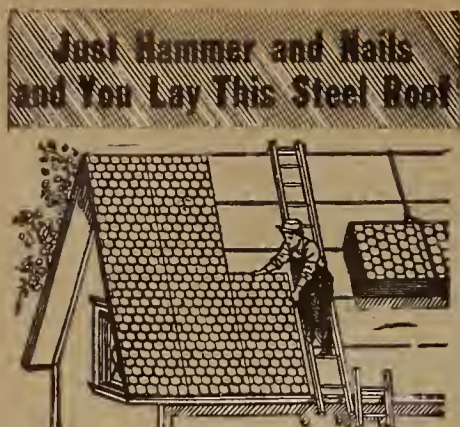

**Just Hammer and Nails  
and You Lay This Steel Roof**

**Edwards "REO"  
Steel Shingles**

One man can easily lay these everlasting steel shingles. Hammer and nails all that is needed. Our patent interlocking device covers all nails, thus preventing rusting, leaking, etc., and also guards against any expansion or contraction that might be caused by the weather. Our \$10,000 Guarantee Bond against lightning protects you for all time against the destruction of your Edwards "Reo" Roof by lightning.

You can apply Edwards "Reo" Steel Shingles over old shingles or on sheathing 12 inches apart. Send us the dimensions of your building and we will tell you the exact cost of material, freight prepaid to your railroad station.

**Special Money-Making Proposition to One Man in Each Community!**

Write for it at once. Get our free Roof Book and select the handsomest, most durable roofs for your buildings.

Write for Free Standard Roofing Book No. 888.

**THE EDWARDS MANUFACTURING CO.**  
808-858 Lock Street, Cincinnati, Ohio (62)

The World's Largest Manufacturers of Steel Roofing

**Begin NOW!**

A man read THE AMERICAN MAGAZINE for a year, and then, catching its spirit and enthusiasm, wrote:

"THE AMERICAN MAGAZINE is winning great favor because of its sound tone of real optimism—not silly, flat and fake optimism, but that optimism which is founded on the solid truth that you ought to do your job well wherever you are, and that if you do your job well you will get some sort of a reward for it here on earth—not necessarily money (which most of us foolishly use as the only yardstick of success), but perhaps an inner feeling of satisfaction.

"This is a poor and inadequate statement which only partly covers the ground. It is only meant to be a sort of reflection on what seems to be the moving spirit back of THE AMERICAN MAGAZINE. It is nothing but an impression which the writer feels after reading and enjoying THE AMERICAN MAGAZINE for a year."

Begin reading THE AMERICAN MAGAZINE now. Do not delay. It is too good and too fine to miss.

15 cents on all newstands. \$1.50 a year.

**THE AMERICAN MAGAZINE**

381 Fourth Avenue, New York

**REPRESENTATIVE WANTED**

We wish to be represented in this locality by a thoroughly reliable party. This is an excellent opportunity for large returns with pleasant work, for an attorney, bank cashier, or an investment salesman.

We handle only the highest grade municipal and other investment bonds.

Address, Bond Department, Desk A

**FARSON, SON & COMPANY**

First National Bank Bldg. Chicago, Illinois

Established 35 Years



ANYBODY CAN LAY IT.

**Rubber Roofing**

Warranted For Twenty-Five Years.

**FREIGHT PAID** To Any Station East of Rocky Mountains, except Texas, Okla., Colo., N. D., S. D., Wyo., Mont., N. M., La., Ga., Ala., Miss. and Fla., on all orders of three rolls or more. Special Prices to these States on request.

**ONE-PLY** . . . Weighs 35 lbs., 108 Square Feet, \$1.10 per roll.  
**TWO-PLY** . . . Weighs 45 lbs., 108 Square Feet, \$1.30 per roll.  
**THREE-PLY** . . . Weighs 55 lbs., 108 Square Feet, \$1.50 per roll.

**TERMS CASH:** We save you the wholesalers' and retailers' profit. These special prices only hold good for immediate shipment.

**Indestructible by Heat, Cold, Sun or Rain.**

Write for FREE SAMPLES or order direct from this advertisement. Satisfaction guaranteed or money refunded. We refer you to Southern Illinois National Bank. **CENTURY MANUFACTURING COMPANY, Dept. 573, East St. Louis, Ills.**

**When To Sell Hogs and Corn**

By Henry C. Taylor

Professor of Agricultural Economics, University of Wisconsin

THE regions in which the corn is fed to hogs is indicated by Chart III., which shows the location of swine in the United States. It will be seen that the hog-belt and the corn-belt are the same in general outline, and yet upon closer examination of these charts it becomes evident that there are parts of the corn-belt where hogs are kept in small numbers. Central Illinois, for example, is one of the regions of densest corn-production, but hogs are scarce. A cattle-map would show a scarcity of cattle, also. This is a region where about half the plow-land is kept in corn. The rotation most favored

The contrast between Iowa and Illinois in regard to the uses made of the corn is interesting. By comparing Charts I. (see last number of FARM AND FIRESIDE) and III, it will be evident that the Iowa farmers feed their corn.

**Causes Influencing Hog Prices**

Corn being the principal hog-feed in the United States, it is a matter of interest to compare the price of corn and the price of hogs. The supply of hogs being fed influences the demand for and the price of corn. On the other hand, the higher the price of

**Hogs Will Drop to Four Cents**

Madison, Wisconsin, July 14, 1911.

MR. HERBERT QUICK, Editor FARM AND FIRESIDE, Springfield, Ohio.

Dear Mr. Quick—I regret that I could not bring the hog-price chart down in time to include the more recent price statistics. The price of hogs is still on the decline, and if I were to venture an opinion, it would be that hogs will go as low as four cents by January 15, 1912. I have just returned from a thousand-mile automobile trip through the corn-belt. There is every probability that there will be a large crop of corn. Observation and conversation with farmers lead me to believe that the supply of pigs in the country is very large. Many people have been attracted by nine-cent hogs and are expanding their hog-growing interests. These facts, coupled with the fact that the high price of pork in recent years has to some extent resulted in substitutions of other forms of food which may permanently impair the demand for pork, lead me to the belief that there is danger at this moment of overdoing the hog business, and also danger of depressing prices on the hog market during next winter.

Yours sincerely,

H. C. TAYLOR.

is corn two years, oats one year followed by clover, and then corn again for two years. The corn is put in large cribs by horse-power elevators, shelled by machinery and put upon the market.

The nearness to the Chicago and Peoria markets may account in part for this method of disposing of corn instead of feeding it. It costs more to ship corn than the hogs which could be fattened from the corn. The farther

corn, the less profitable it is to feed corn to hogs; hence the price of corn influences the supply of hogs. This is shown clearly in Chart IV.

The feeding of corn to hogs was unusually profitable during the years 1906 and 1907. This stimulated the swine industry until the number of hogs to be fed from the 1907 crop was the greatest ever known in America (Chart IV.). The hogs required



Chart III.—The production of swine in 1900. One dot represents 2500 head. Compare with Chart I. published last issue. The crowding together of dots has again caused a heavy shading over certain sections. Note the relation hogs bear to the corn belt

the corn-grower is from the corn-market, the more he gains by converting his corn into hogs which weigh only about one-sixth as much as the corn required to produce them.

**Tenant-Farming Bad for Stock-Raising**

But there are doubtless other reasons. About half the farmers in the corn-belt of Illinois are tenants. Tenants, as a rule, lack capital. They want and need quick returns and they care little about producing manure to put upon the land for the benefit of the next tenant. They expect to move when the land becomes so poor that it will not bring large returns. With that in mind the manure is neglected.

so nearly all the corn that the supply available for industrial purposes was very small. A hog half grown has to be prepared for the market even if the price it will bring

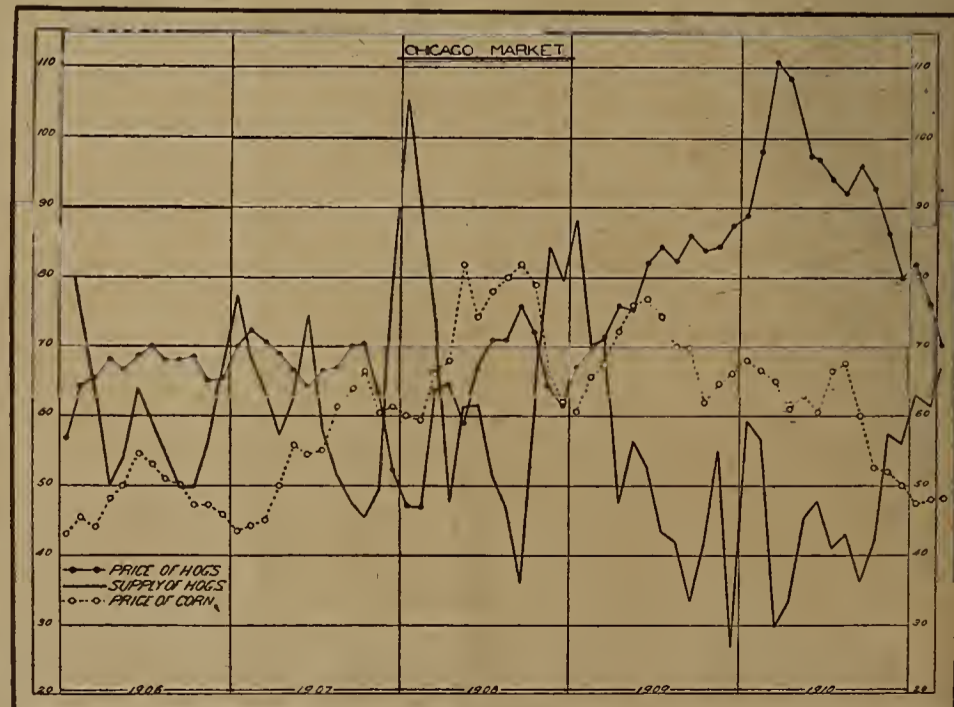

Chart IV.—The relation of the price and supply of hogs to the price of corn at Chicago. The figures on the margins of the chart represent (1) the monthly high price of corn in cents per bushel; (2) the monthly high price of hogs in tenths of cents per pound; and (3) the monthly receipt of hogs in tens of thousands. This chart is well worth studying. The year 1910 shows remarkable profits in hogs

would not justify the rearing of the pig, for the only way to realize anything on the investment already made in producing half-grown pigs is to continue adding to the investment until they can be marketed. In 1908, this required the feeding of high-priced corn to relatively low-priced hogs (Chart IV.). Farmers fed corn to hogs with the feeling that they would have made more money had they sold the corn. This condition resulted in a decline in swine-breeding. The resulting reduction in the demand for corn for the feed-lot, accompanied with an increased production of corn, brought into operation the forces which explain the present downward trend of prices on the corn market.

The supply of hogs on the Chicago market varies greatly from month to month (Chart IV.). The receipts reach the maximum in the winter months, usually in January, and fall to the lowest level in the summer and fall. The fact seems to be that hogs are bred with a view to having a large number at the proper age to fatten when the corn-crop is ready for use. This seems to be an economical arrangement. The summer months give the best time for young hogs to make a rapid growth at a minimum expense for feed, shelter and labor. The quicker the corn is converted into pork, the smaller the loss from shrinkage. The interest on the investment is also a smaller item. Furthermore, this system calls for the greater amount of labor upon the hogs at times of the year when there is less opportunity for profitable employment of labor in the field. This suggests that the farmer can afford to sell hogs more cheaply in the winter than at any other time. The farmer may do well to make some calculations, however, as to whether the lower price he receives in the winter does not more than counterbalance the lower cost of production.

Viewed from the standpoint of the packers, an even supply of hogs throughout the year would enable them to utilize their packing-houses more completely. In order to handle the enormous arrivals of hogs in January, it is necessary to have much larger packing-plants than would be needed if this supply were spread out over all the months of the year. This means large investments in land and buildings which are used only a part of the year. The interest on this investment is properly charged against the product and must result in a higher price to the consumer of pork, or a lower price to the producer of hogs than if the packing-plants could be used to their full capacity the year around. Economic forces may operate in such a manner that all the interest and fixed investments will be paid out of the pork packed in the winter months and little or none of it by that packed in the months when small numbers of hogs are available for packing. This may be illustrated by thinking of a beet-sugar factory which stands idle a large proportion of the year. The owners might be induced to use that factory during the summer to refine cane-sugar even if the operation paid almost nothing beyond the extra expenses involved, because it would give employment to the regular employees at a time when they would otherwise have little to do. The packers can likewise afford to pay a price for hogs in the summertime, which leaves little or no margin for interest on the packing-house investment, in order to keep the regular employees earning something during these months.

It cannot be expected that a complete survey of the causes which influence prices should be given in the space here allotted, but two more points should be noted.

**The Prices of Cotton and of Hog Products**

It has been seen that there is a relation between the price of corn and the price of cotton because these are competing crops. Indirectly this means a relation between the

price of cotton and the cost of producing hogs, but there is also a close relation between the forces which determine the price of hogs and the price of cotton and cottonseed, because cotton-seed and hogs compete in supplying one of the articles used in every household. Lard and the cotton-seed substitutes are in open competition. The more people use of the one, the less they will demand of the other, and the lower will be the price. It will be noted that cotton-seed products will have a greater influence upon the lard-hog of the corn-belt than upon the bacon-hog of other districts.

**Legislation and Hog Prices**

There is a relation between the price of hogs and the legislation against butter substitutes. Butter substitutes contain a large percentage of neutral lard. The greater the extent to which butter substitutes are used, the greater the demand for lard and the higher the price which can be paid for lard-hogs. This applies to the price of fat cattle, also, for the butter substitutes contain a large proportion of tallow. Legislation should not tax one product for the benefit of another, but everything should be sold under an honest label. This should be required by law and the law enforced.

The purpose of this discussion of prices is to stimulate thought. Careful thinking on these questions will increase the profitability of farming, eliminate some of the legislation which has for its purpose the robbing of Peter to pay Paul, and give a clearer insight into the economic world in which we live.

**The Tea Cure for Insurgency**

[CONTINUED FROM PAGE 4]

Sometimes, when we see him standing around hurrhless that way, we feel that without a countess it might not be wise to round up a thousand farmers and start them on this new cure as if you were chasing a flock of sheep through a tank dip. We don't know just what horse-power a full-blown countess exerts as a drawing card, but in this day of thoroughbreds there's probably nothing that catches the eye and rivets the attention of the farmer like a countess with a pedigree as long as a piece of rope. You can throw almost anything into a man whose attention has been riveted by a countess. A boiler factory can't hold a candle to a countess in the riveting business. But suppose it should be tried without a countess and the farmers should all go swarming up the governmental framework and push its cupola off? In our own country—where we don't raise any countesses, except a few for export—we should consider this. We can't lie down in idleness. We must be up and doing until we get that Canadian viewpoint.

Governor-General Grey takes a very roseate view of the future when he says: "Let the good work go on and on and on—like the throb of a mashed thumb—until the too-ambitious farmer, orientalized by the Elysian vapors of tea, and emancipated from the thralldom of desire, plows the landscape with a hump-backed buffalo harnessed to a forked stick—till he grows a queue and wears his shirt outside his pants—till he babbles a jargon that looks in print like a crow's nest crossed with the signs of the zodiac. In our mind's eye we see him five thousand years from now, resting his fence-board sandals on the brick stove in his hut of bamboo reeds and mud, hitting the opium pipe in contentment and singleness of heart—a picture of pastoral simplicity unfretting to the soul of politician or captain of industry, and a living testimonial to the beneficent reign of tea."

It is all right to be roseate, but we should not be too all-fired roseate, either. Did you ever associate with bull-snakes much? A bull-snake can come nearer making your heart climb the latticework of your thorax and dive into your stomach for safety than anything else this side of Gehenna. He's a meek, sort of resigned-looking, snake in the face—but when you crowd him, he rises right up out of the tall grass and stands on the tip end of his tail and lets out a beller that leaves him in undisputed possession of the field. Our statesmen must be particularly careful, or the farmers will all do that at once some day, and for about eighty-seven years after that event you can run at a statesman with a lightning-bug on a corn-cob and scare him into the tall weeds. And now, brethren, let us rise and sing that grand old hymn:

Sally, put the kettle on,  
We'll all take tea!

**Discontent or  
Presentiment?**



The hog once said:  
"I am well fed;  
They want to make me fat.  
But, seems to me,  
I'd rather be,  
In spite of all, a cat."

**Conditions of the Sheep Market**

DURING the month of June last year, FARM AND FIRESIDE commenced to publish a series of articles under the heading of "Why Not Go Into Sheep?" Those articles were prompted by the belief that the demand for high-class mutton and lamb was already greatly in excess of the supply, while the reverse was true with regard to the larger and coarser grades of both; and by the conviction that a promising field for men of small capital, cultivating farms of from eighty to three hundred acres, was opening up for the breeding and feeding of lambs for the spring and winter holiday markets. Returns were expected to be rapid and almost certainly remunerative, while the keeping of sheep is certain to improve the fertility of the soil.

It so happened that these articles appeared simultaneously with a sharp decline in the sheep-feeding business, which had been, for the most part, paying good money for about eight years; but it must be noted that this decline hardly at all affected the men who bred and fed lambs from their own well-selected ewe-flocks, which had been sired by pure-bred rams of one of the Down breeds. It is assumed that the lambs were fed with care and discrimination, for the most part with the produce of the oats, corn, forage and root crops of the local farms, and marketed when ripe, neither sooner nor later. There has never been a time when these lambs, ranging from sixty to eighty-five pounds, got below the seven-dollar to eight-dollar mark; they form the class which the public demands, and which never becomes a "drug" to the market.

But the good democratic law that the majority shall rule has held good with the sheep, and unfortunately the majority has been composed of some of the worst riff-raff of half-fed, half-bred grassy culls of both sheep and lambs ever sent to our markets. So great has this crowd been that the always reliable *Breeders' Gazette* quite lately reported that thousands of these derelicts could be seen "lying on pasture near Chicago, awaiting an opportunity to come in." I am afraid that this state of affairs cannot be regarded as merely temporary. There must be lots of this stuff to be worked off, and it does not seem that it will be good policy for those feeders who have much of it on hand to try to force it on the market at present. The recent rains have worked wonders with the grass and forage crops over a big territory, and sheep can be kept on at little expense. If frequently shifted about, and given a few oats or a little corn to correct the laxative tendencies of the bush pastures and the dangers from parasites, they can be trusted to go on improving till this rush is over. At the same time those who have really prime lambs to offer can, I think, feel quite safe in sending them along to market.

It becomes a matter of much interest to discover the causes of the great losses which have unquestionably fallen on the sheep-feeders, especially on those of the West, and many experts have kept their brains sizzling during these hot days and nights to discover them. All those interested in the subject say that we are becoming a mutton-eating people, but to this must be added, in order to get the right view of the situation, that we have become experts in the judgment of it, as to what constitutes the good, the medium and the rankly bad. I have a habit of talking with the most intelligent of the meat-market men I can reach, and they all say that the ladies are becoming keen judges in this regard.

Our rapidly increasing foreign population, a vast number of whom come from the peasant classes of mutton and goat eating people, will, in course of time, become consumers of the larger and fatter grades, but the American-bred man is not a fat-eater, and it is his taste which governs the market. He will have what he wants, which is the best of everything. Those who will go to the trouble of providing it, be it necessity or luxury, will reap the always-liberal harvest.

If this is true, it provides, in my estimation, one very good reason for the recent slump of the sheep business. It is on the big western feeders that the recent losses have mostly fallen and, I must say, I think with some justice, because they have shown a most remarkable recklessness both in the prices they have paid the range breeders for their lambs and in the green state in which they have sent them by thousands to the stock-yards. Their methods of buying have given the breeders, at the one end, the best of it, and likewise the ever wide-awake buyers at the stock-yards at the other end. Buying in the lump, without sufficiently close and careful selection, at a lump sum for the bunch; an eagerness to keep in a game which has for some years been paying them well, and the fact of having provision made for accommodating a large number has put the matter of the price they had to pay much in the hands of the men from whom they had to buy. Added to this, that for two years a partial drought has raised the price of hay, and that at least a million more sheep were being fed during the six months than during the corresponding period of the previous year, and it does not seem very difficult to get at the root of their troubles. And here, as usual, I look around for the "silver lining" to the cloud, and I think it is to be

found in the lesson that all this will give to those who have, through a long period of good success, become reckless; and in the fact that the conversion of what was range into homesteads will either do away with much of the feeding of bought lambs, or induce a great number of holders of medium areas of land to breed and feed well-bred lambs of the strictly mutton breeds. The remarkable activity which has characterized the shipments through Louisville and the eagerness with which buyers have taken them up at prices ranging from \$7 to \$7.75 has shown pretty clearly the truth I am contending. I have heard that the quality of these lambs was very high, and that, as a rule, they came in to the yards in fine condition, and without doubt they must have made very satisfactory returns to their breeders and feeders. All this is so greatly in contrast to the depressed reports from the large feeders of the West (to which, however, exceptions must be made on behalf of some Colorado and some Mexican lambs which have done fairly well) that it cannot fail to confirm the belief that there is always room at the top of the ladder. Success will come to the farmer of limited acreage who will try the experiment with a small flock of well-chosen ewes, not necessarily pure-bred, but fairly good graders of any of the Down breeds, or, if more convenient, of Rambouillets when such are mated with a pure-bred ram of a mutton breed, preferably a Shropshire. Of course, all must steadfastly abide by the rules as to care, feeding and mating.

Many years ago, I went through the mill of disastrous sheep seasons, but in this line of the business I have never failed to come out ahead. In this regard it is pleasant to record that, notwithstanding the depression naturally caused by recent losses, in going pretty widely over the correspondence to be found in the *American Sheep-Breeder* and similar publications, I have found letters written in a very cheerful and hopeful vein as to the sheep prospects for the coming season. The only discordant note was struck when the possible effects of the reciprocity treaty was mentioned. But that has not passed yet.

Sometimes I come across lamentations that we are being knocked out of the European markets by Australia, New Zealand, our South American neighbors and even China, which has recently shipped a cargo of frozen mutton to London. But I do not think we need fret about that, so long as our population goes on increasing as it has done lately, and so long as we go on improving the quality of our own mutton products.

JOHN PICKERING ROSS, Illinois.

**CREAM SEPARATOR  
USERS**

Finally Buy  
**SHARPLES  
Dairy Tubulars**

Others have tried disk-filled, complicated or cheap cream separators—and have discarded them for Tubulars. A steady stream of such machines reaches us daily.

There is the best reason in the world for this: Dairy Tubulars contain no disks—have twice the skimming force of others—skim faster and twice as clean—wear a lifetime—are guaranteed forever by America's oldest and world's biggest separator concern.



Mr. Perry Faringer, Mill Hall, Pa., says: "Have been using Tubular over nine years. Has cost only 5 cents for repairs."

Other separators are still built on a principle we abandoned over 10 years ago. They cannot be compared to Tubulars. You will finally have a Tubular—why not get it first?

Don't you send a cent away—or pay a cent for freight—to try any separator. You can try the quality separator—The World's Best—the Tubular—without investing one penny. Ask us about it.

Other separators taken in part payment for Tubulars.

Write for catalogue No. 112.

**THE SHARPLES SEPARATOR CO.,**  
WEST CHESTER, PA.  
Chicago, Ill., San Francisco, Cal., Portland, Ore.  
Toronto, Can. Winnipeg, Can.

**ELECTRIC  
Steel Wheels**



Fit all running gears. Get a new wagon just by buying wheels. Unbreakable, almost everlasting. All heights and tire widths. Also new Electric Handy Wagons. Write for book on "How to Make Old Wagons New." Free.

**ELECTRIC WHEEL CO., Box 13, Quincy, Ill.**

**95 and Upward  
AMERICAN  
SEPARATOR**

FREE TRIAL, FULLY GUARANTEED. Easy running. Easily cleaned. Whether dairy is large or small, obtain our handsome free catalog. Address **BOX 1058 AMERICAN SEPARATOR CO. BAINBRIDGE, N. Y.**

**Cure That Lame Horse  
Without Risking A Penny**

**We Take All The Risk, And Protect You With A \$1000 Guarantee Bond**



He Asks You  
TO  
Please Send This

WE want to show you that there isn't any affliction causing lameness in horses that can't be cured, no matter how long standing. We will do this for you absolutely free. Fill out the "Free Diagnosis Coupon" and send it to us at once.

It means money to you to relieve your horse of its misery at once. Ask us—and you will get the best and most reliable diagnosis absolutely free. All you have to do is fill out the "Free Diagnosis Coupon," mark just where your horse has a swelling, sore or any one of the big number of possible causes for lameness, and send it to us. We will then give the coupon to our trained Veterinary Specialist for his expert diagnosis. This diagnosis is invariably correct. We then inform you of the cause of your horse's lameness and the remedy that will absolutely cure him. We do all this for nothing.

**Be Positive, Know What You Are Doing** and know that you are treating the right spot in the right way. Don't disfigure your horse and reduce his market value. Write to us. Get our "Free Diagnosis." You paid good money for him when he was sound. What is he worth to you now, or anyone else when he has a Spavin, or Ringbone, Thoroughpin, Curb, Capped Hock, Shoe Bol, Sprung Knee, Ruptured Tendons, Sweny, or any one of a hundred different causes of lameness that your horse might be heir to. You know that he isn't worth 50 per cent, nor 25 per cent of his original value.

**Relieves Cases Formerly Considered Incurable**

No matter how long your horse has been lame, or what the nature of his lameness, you can absolutely rely upon Mack's \$1,000 Spavin Remedy. We know of many cases where owners have paid out big fees and had valuable animals tortured with "firing," "blistering" and other good-for-nothing methods and as a last resort tried Mack's \$1,000 Spavin Remedy, and were amazed at the painless, positive, quick and permanent cure.

**Nearly Every Mail Brings Us Letters Like the Following:**

"The remedy you sent me cured the two horses that the hoof was coming off. The mule's foot was nearly off when I got the medicine, but in five days the mule was able to walk on it. The horses are working every day, and have been since using your remedy the third day. It is the best medicine I ever saw for the foot. Our Vet said those horses would not be able to work in 12 months, but he sees his mistake now. I recommend your medicine to every one as I know it is all O. K." Yours truly, Ludowici, Ga., Dec. 7, 1910. J. T. COLLINS.

"I am pleased to tell you that Mack's THOUSAND DOLLAR SPAVIN REMEDY has proved far beyond my expectations. My horse had been lame with side bones on each side of foot for about eighteen months, and I had thought of shooting him at different times. I tried to work him but he would go so bad he would hop along on the legs. My neighbors told me he would never be of any use as they had had horses with the same trouble. I tried other remedies without success, but am working him now and he is sound, and have tested him well. I recommend your Mack's \$1,000 Spavin Remedy to all." Yours truly, Summerland, B. C., Dec. 4, 1910. R. H. STEWART.

**Your Druggist Will Obtain Mack's \$1,000 Spavin Remedy For You** if you ask him. Price \$5.00 per bottle. If he refuses, remit \$5 to us and we will see that your order is filled without delay. Every bottle is absolutely guaranteed, and is accompanied by our \$1000 Warranty Bond, which insures you that your money will be refunded if the remedy fails to do all we claim for it, as stated in our guaranty.

**McKALLOR DRUG COMPANY**  
Distributors Binghamton, N. Y.

**FREE DIAGNOSIS COUPON**



On picture of horse mark with an X just where swelling or lameness occurs, then clip out coupon and mail to us with a letter, telling what caused the lameness, how long horse has been lame, how it affects the animal's gait, age of horse, etc. We will tell you just what the lameness is, and how to relieve it quickly. Absolutely no charge. Write today.

**Free Book "Horse Sense"** Send us the Free Diagnosis Coupon, get absolutely free a copy of our book "Horse Sense." Describes and illustrates disease of horses' limbs, shows correct name for every part of horse and tells valuable facts every horse owner ought to know.

# A Personal Word To Farmers' Wives

**T**HERE is a special point about the **WOMAN'S HOME COMPANION** that we want to make. We have explained that the **COMPANION** is a big and beautiful woman's periodical—the best in its field—and that it is published by the publishers of **FARM AND FIRESIDE**. We have explained that it not only entertains with the best stories and articles and illustrations available, but that it performs a time-saving and money-saving service by giving valuable household, dressmaking and cooking suggestions—suggestions worth money, yet free to every subscriber. There is another point, however, of advantage to the subscriber.

**T**HE **WOMAN'S HOME COMPANION** contains three departments to which housewives may contribute their own ideas, and if the ideas are acceptable to the editor, they are paid for.

Now we are going to take up one of these departments, "The Exchange," and let you see just what you might do for it. It is a department of household news—contributed entirely by subscribers, and paid for by us in cash. The items of news are short. Right here let us illustrate by a sample item written by a woman in the State of Washington and accepted by the **COMPANION** recently:

**A Time and Energy Saver** In pressing tomatoes or anything through a colander or sieve, do so with a jelly-tumbler or any dish that has a curved-in bottom. It will hold the food and force it through, and do it many times more easily and quickly than by using a spoon.  
*Mrs. R. H. A., Washington.*

**I**N THE current **COMPANION**, the August number, it is announced at the head of the "Exchange" department that every month prizes are awarded to contributors of the best ideas:

\$5.00 for the best original item (not illustrated) of general interest and helpfulness in solving house-keeping problems.

\$3.00 for the second best.

\$5.00 for the best description of an original home-made household convenience or labor-saving device, accompanied by a rough sketch.

\$3.00 for the second best.

All other accepted contributions, whether illustrated or not, are paid for at the rate of \$1.00 each.

**T**HIS is the point that we want to emphasize—namely, that you can have a part in making the **COMPANION**. You can pass on to others the practical suggestions you have developed in your housekeeping experience—an opportunity of peculiar desirability, since you will be paid for good ideas accepted by the editor.

It would pay you to begin taking the **WOMAN'S HOME COMPANION** immediately. You will save many times its cost in the practical service it will perform for you, and perhaps you can contribute to it also.

15 Cents on all news-stands. \$1.50 a Year

**THE CROWELL PUBLISHING COMPANY**

Springfield, Ohio

## Headwork Shop A Department of Keen Kinks and Pertinent Points

### Guardian of the Hen-House

**H**AVE an electric-bell (A) in your dwelling connected with the hen-house as shown in the sketch. One wire goes direct from bell to hen-house. The other goes to switch (B), then to batteries (C) and then to hen-house. These two wires are insulated and inclosed in a pipe buried about ten inches underground. I ran my wires down into the cellar and out through the cellar wall low down where they do not show. At the hen-house end these wires run through the wall low down and up beside the door casing to just above the bottom hinge, where they connect to a "door spring" such as you can buy or perhaps make (see enlarged figure one at top of sketch).

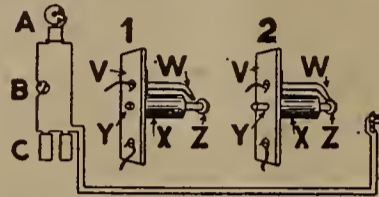

This is simply a brass plate (V) with a steel prong (W) on it, insulated from the plate. On the plate is also fastened a cylinder (X) containing a spring which tends to pull plunger (Y) inward, so that the steel button (Z) on end of plunger will strike the prong. A hole is bored into the door casing to receive prong and cylinder, the plate lying flush on the door casing. When door is shut, plunger is pushed out, so that button is held away from the prong (see Fig. 1, top of sketch). But when door opens, plunger is drawn in and button strikes prong (see Fig. 2 above). One wire is connected through the plate (V) with plunger and button and the other wire connected with the prong, so the circuit is completed and the bell sounds an alarm.

Daytimes the switch at house is left open, so door may be opened without ringing bell.  
HARRY T. HOLDER.

### Ever-Ready Gate Slam

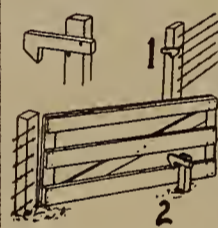

**H**ERE is a gate latch hand slam always ready to hold the gate open or shut. The sketch shows the position of latch on stake, which is driven in the ground at the desired place and latch fastened at a point high enough to catch over the lower board of the gate. A wire nail is driven into post just tight enough to allow the latch, which is made from an inch oak board, to work freely.  
W. G. STICKEL.

### No More Dusty Hay

**S**OME time ago, I saw a device that seemed to me to be worth while copying. We all know what a mess of dust and dirt and fine hay always gathers in the bottom of the horse-mangers after several weeks' feeding. The device I speak of was a door in the front of the manger-box big enough for a man to work in without crowding. The bottom of the door was even with the bottom of the manger, so that it was easy to clean out the trash.

It is commonly believed that half the breathing trouble of farm horses is caused by compelling the horses to eat from a dish whose floor is covered with dust which they must breathe and eat, in order to get the last of the hay.

It would seem that this door idea would be a lot of bother if there had to be a door for every manger, but in this case one door cleaned two mangers, and I cannot see why with several mangers connected together one door would not serve for all of them. This clean-out opening faced the front into the feed-alley, which is not as good an idea as to have it to the rear or so that this trash would be swept into the stall and made into manure. There would be some trouble about some horses opening such a door, but a good catch would prevent this. R. E. ROGERS.

### Post-Lifting Kink



**T**AKE an old, solid, corn-planter wheel and set it as closely against the post as the chain will allow. Put a hook (A) on the end of the main chain, using a shorter chain to go around the post just at the top of the ground. Hitch a horse at B with a long singletree. This is the best post-lifter I ever used and can be rigged up in the shortest time. The upward pull on the post may be increased by placing a triangular block in front of wheel. O. GUY RHONEMUS.

### Solid Sod Hog-House

**H**ERE is an economical way to build a warm, comfortable hog-house where lumber is scarce and high. Plant four posts for corners of house and stretch tightly between them small-mesh woven wire fencing—No. 14 wire will do. Build a wall of sod against the wire outside. That gives you a solid wall the hogs cannot root down. Roof in any way desired.

Hog-house floors that cannot be rooted up can be made similarly before the walls are built. Fasten a strong pole at level of ground, to the posts at one end, and staple netting to it. Staple other end of netting to a pole laid outside the posts at other end of house. Twist the second pole, drawing netting taut on ground. If two strips of netting are used, wire their edges together. The litter will work through and the floor become very hard. F. L. BOOTH.

### The Dairy Switch-Board



**S**TRETCH a strong wire tightly across the cow-stable just above the rear end of the stalls (or platform on which the cows stand) and high enough to be out of the way. Take a board one inch thick, twelve inches wide and five feet long. Make two long hooks of stiff wire and staple to one end of the board. Hang the board on the horizontal wire and move up to within six inches of cow. The board should hang even with cow's hind foot. Take your seat on the milk-stool and go to milking. If Mrs. Switcher wants to use her tail, let her switch. The board, and not your head, catches the tail. Sketch shows how.  
PERRY HAM.

### Carriage Whip-Holder



**T**AKE a piece of board three inches wide and twelve inches long, and bore several holes in it as large as a wooden clothes-pin. Saw off the knobs on the clothes-pins and fit them in the holes in the board. Nail this up in the carriage-house on the wall and strike at it with the cracker of the whip, then let go the whip and it will hang there. You can hang up as many whips as there are pins in the board. This will keep the whips straight.  
RUBEN FULMER.

### A Costless Whip-Holder

**I**N DRIVING around in your big road-wagon, it is always safer to have a whip with you, but it is a bother carrying it in your hand all the time, while a whip lying down in the wagon-bed, as I have often seen them, is quite useless if you need it in a hurry. The simplest whip-holder I ever saw was made without any expense or material. Simply a hole of suitable size bored down through the slanted foot-rest board, which is on the front of every factory-made wagon-bed, allowing the whip, when dropped through, to fall behind the rod which holds the side-boards of the bed together and finally rest its butt on the projecting ends of the bottom boards. If properly put in, near a side-board, it can never work loose or fall out, nor are you ever bothered by your socket getting filled up.  
PAUL R. STRAIN.

### To Save Trimming Lawns

**T**O SAVE trimming the lawn after mowing, a good plan follows:

First I secured a wheelbarrowful of good, clean sand, then a sharp hoe. With the hoe I cut away the sod a distance of about five or six inches around all the trees, shrubs, fence-posts, etc., in the lawn, and also along the foundation of the house (note sketch) and the wooden sidewalk. I cut down about two inches, then, after carrying away all the



dirt and sod, I filled in, where I had hoed the sod out, with the sand, using a small fire-shovel, and bringing the sand up to the level with the lawn. This was very effectual in keeping the grass away from around the shrubs and tree roots, and did not detract from the appearance of the lawn. That was three years ago, and it was only recently that I had to "repair" my work.  
HENRY L. CLOSZ.

Tack a piece of leather, roofing, or any like material on your wagon-axle, letting it extend out over the hub of the wheel a couple of inches. It will help keep out sand, dirt and all foreign substances, which work in and ruin skein and spindle.



## Poultry-Raising

### Green Feed for Geese

A MARYLAND reader who raises some good poultry says: "Last season I started with a trio of fine, large geese and raised a nice lot of goslings. They were in excellent condition until two weeks ago. One of the old geese seemed to lose the use of her feet one evening, and she died the next morning. The other goose commenced the same way, four days ago. Refused to eat and walked as if exhausted. Finally stretched out and was two days dying."

"I keep them in a one-fourth-acre yard, in which there is a pond of water that runs from a spring. I feed as follows: Mornings, meal, bran, middlings and beef-meal. Evenings, I feed corn."

"I also lost two ducks. There is nothing that they can get to poison them. No one here seems to know what is wrong. Some think the ducks might have eaten tadpoles. Will tadpoles kill ducks or geese? Can I raise geese in a one-fourth-acre yard, with pond?"

The geese were getting far too much concentrated food. They do not require meat or any form of animal food. Grass or its equivalent is the natural food for a goose. A little ground grain, or whole grain, scalded and soaked, may be fed twice a day, in winter, with good results, but highly concentrated mixtures, such as mentioned, should be avoided. If grass is scarce, the geese should be provided with something in the way of roughage. Silage is a very good substitute for grass. Alfalfa, scalded and steamed, is good, also cut clover. We sometimes use the former as a basis for the mash. At other times cooked vegetables are used. In either case, equal parts of corn-meal and bran are added to thicken it a little. Unless geese are being fattened for market, the greater part of their ration should be grass or something that will take its place. Green rye, when cut and stored in a frozen condition, will keep for a long time and is good for both geese and ducks in winter. Raw cabbage, turnips, inferior apples or even potatoes, chopped into small pieces and mixed with bran either dry or moistened, will furnish a variety to the ration that will be found beneficial, especially when the geese are laying. A little powdered charcoal is added to the feed every day. Salt just enough to flavor it is added twice a week.

Grit is always provided in the form of broken sandstone, crushed oyster-shell and coal-cinders. If water-fowl cannot get sufficient grit, they will sometimes have indigestion and get very weak. As a rule, ducks, both old and young, require more grain than geese, but they also need plenty of green stuff. They cannot thrive without it. Neither can they thrive upon grass alone. Of course, both goslings and ducklings should be kept separate from the old birds. Never keep geese and ducks in the same yard or house. Both should have good, dry houses or shelter to stay in at night. If they have to set upon the damp ground, they are apt to take cramps, rheumatism or roup.

A yard containing one fourth of an acre would not be suitable for a large flock of water-fowl. If there is an abundance of pasture upon it, four or five large geese could be kept in a lot this size the year around, but they would need some extra roughage. About twenty goslings could be kept confined in a lot this size with good results, or not over forty young ducks.

A yard with a pond in it is all right for matured birds, but is a very poor place for the young ones. Neither goslings nor ducklings require a pond; in fact, they are far better off without one. They grow faster with only sufficient water to drink. The old birds do not really require a pond, but if there is one within reach, they will spend much of the time in summer swimming and "padding."

ANNA WADE GALLIGHER.

### How "Indian Runners" Were Named

IN THE paper of April 10th, I read the article on the Indian Runner duck. FARM AND FIRESIDE readers may be interested to learn how the Indian Runners secured their names. My husband, Lancelot T. Pickering, late of Bongate, Appleby, Westmoreland, England, was the godfather, or namer, of Indian Runner ducks nearly thirty years ago. A friend of ours had two ducks and one drake given to her by a friend who was a sea captain. Mr. Pickering was visiting in the neighborhood, and called to see her, and he saw these ducks and asked what breed they were. She said she did not know where they came from, but that they were top layers, better than her hens. About that time a celebrated runner, an Indian, named Deerfoot, won the world's championship for long-distance running, so I said, "We'll call those ducks Indian Runners," as they could (minus the duck waddle) run, and she saved me a setting of eggs, and from that setting I sent eggs and the breed all over the world, some very early to Belgium

and Holland, France and Germany. We gave up breeding them nine years since, and here, in Virginia, we do not raise any. There are no runners in India, only what went from England to a maharajah, sent by Mr. J. H. Wilson, a great poultry enthusiast. He was also a breeder and exhibitor and judge, and was instrumental in getting the Indian Runner Club formed.

MRS. LANCELOT T. PICKERING.

### The Turkey Harvest

ONE reason why I look on turkeys as the most profitable of all poultry, is the cheapness of their keep in summer, when they seldom come home and really do double duty in the way of making savings for the farmers; for not only do they pick up their own living, but they destroy multitudes of destructive insects. It is better that they do not come home, for they would get lice and mites from the chickens, and those pests bring sure death to little turkeys. If they do get lice or mites on them, grease them under the wings and around the tail with coal-oil and lard (but do not grease them on the head), or dust them well with some good insect-powder. This should be repeated again in about a week and kept up until all danger is past.

As soon as cold weather comes the turkeys will come to the house where they can get plenty of feed. It does not hurt turkeys to drive them after they are grown, though driving does injure young turkeys.

They have been running after bugs and grasshoppers all summer and have very little fat, but they have large frames and are in an excellent condition to lay on fat. Feed them all the corn they will eat. By Thanksgiving-time, or Christmas at least, they will be fine, large birds, weighing from twelve to twenty-five pounds each. The gobblers should be sold, for they are fatter than they will be later. Sometimes it is better to keep the hens a little longer. They will gain in weight right along for a month or two and the price is frequently higher a month or two later. You must use judgment as to that, but do not keep gobblers longer than Christmas.

MAY FULLERTON.

### Late-Hatched Pullets

I FORMERLY argued that "the late-hatched chicken is always a runt and doesn't pay." But last August I set a hen, and hatched a flock for experiment. I pushed them right along, and late in the fall sold and ate all but two little pullets. I was told that they "would never amount to anything," but they looked so fine that I saved them, knowing that they would make a dinner any time, and could walk around until I needed them. One of them began to lay in February; later on I set her, and she makes a fine mother, overthrowing my belief that late hens did not pay.

CLIFFORD E. DAVIS.

Mark that hen for the block that won't molt before November, but save the hen that gets ragged in September or earlier. It means all-winter eggs or none.

Says a New York correspondent: "When scab begins to show on the chicks, let it alone until it hardens. If you do not, you may make it spread a good deal more. After it is quite hard, wet it two or three times with a solution of peroxid of hydrogen. A bit of vaseline afterward helps a lot."

## Double Orchard Profits

PLANT TREES WITH



Red Cross

LOW FREEZING

DYNAMITE

Learn the methods used by Hale, "The Peach Tree King," and other leading orchardists.

Fruit tree planted in dynamited hole

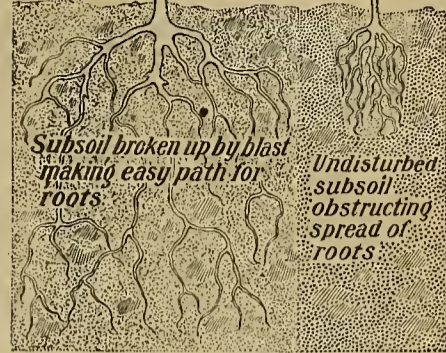

Subsoil broken up by blast making easy path for roots

Undisturbed subsoil obstructing spread of roots



6-year-old apple tree, planted with dynamite

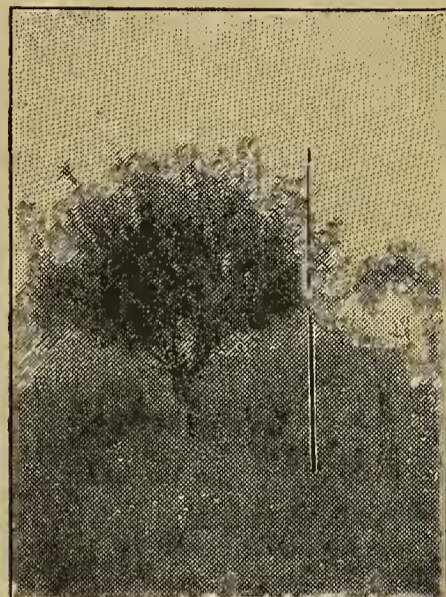

6-year-old apple tree, planted with spade, in the same plot

To learn how progressive farmers are using dynamite for removing stumps and boulders, planting and cultivating fruit trees, regenerating barren soil, ditching, draining, excavating and road-making, write now for Free Booklet—"Tree Planting With Dynamite, No. 90."

E. I. DU PONT DE NEMOURS POWDER CO.

PIONEER POWDER MAKERS OF AMERICA

ESTABLISHED 1802

WILMINGTON, DEL., U. S. A.

Store-keepers wanted in every town and village to take and forward orders for dynamite and blasting supplies. Not necessary to carry stock. Large sale possibilities. Write at once for our Dealer's Proposition. DU PONT POWDER CO., DEPT. 90, WILMINGTON, DEL.

**1 MAN HAY PRESS**

With one horse you can bale a ton an hour with our wonderful Daisy. Self-feed, condenser, bar-sided hopper, and self-threading device, reduce hand work, and materially increase the baling capacity. We have hundreds of delighted users. Write today for circular K-146 which gives testimonials, prices and details of five days' free trial.

GEO. ERTEL CO  
QUINCY, ILL.

**Fastest Hay Press**  
**2 1/2 Tons Per Hour**

Greater capacity is guaranteed in all Spencer Presses. The guarantee with our Alligator Press says "22 tons in 10 hours or no pay." Large feed capacity—smooth and compact bales, uniform in size. Load full weight into cars. All Spencer Presses are biggest money makers because they give greatest capacity at smallest operating and repair cost. Write today for free illustrated catalog L.L. describing full line.

J. A. SPENCER  
115 William St., Dwight, Ill.

Buy Guaranteed Capacity

## "Pittsburgh Perfect" Fence

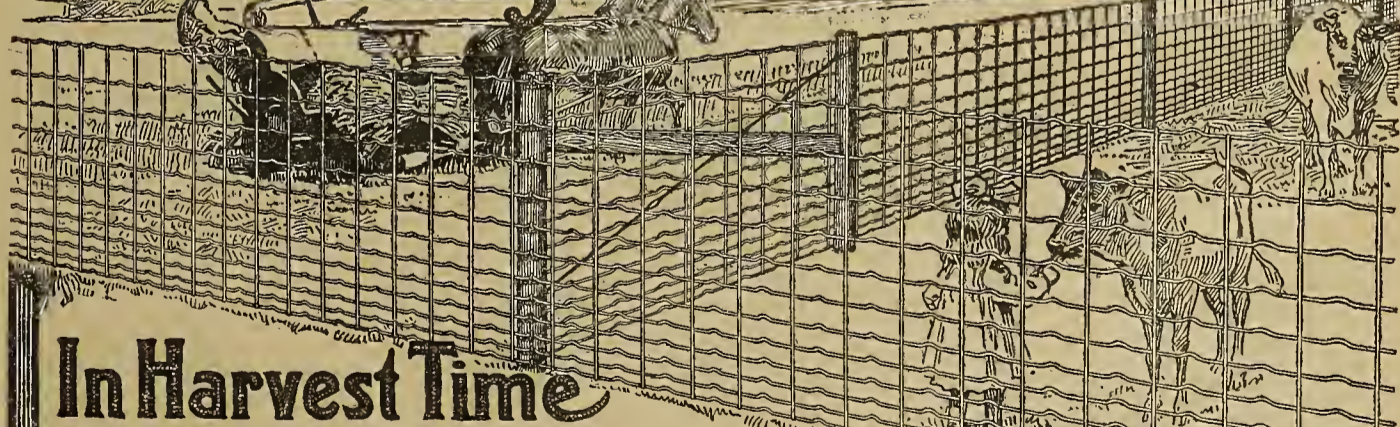

### In Harvest Time

Those shrewd farmers who have stretched "Pittsburgh Perfect" Fence on their property appreciate most keenly in harvest time, perhaps, its unequal strength and durability. It has successfully withstood the elements, the knocks of planting, cultivating, harvesting, the rough usage given it by horses, cattle and hogs—it stands erect, even and firm, as good as new, year in and year out. "Pittsburgh Perfect" Fence owners at all times are reaping the results of highest fence efficiency.

Tough, strong, durable Open Hearth wire—like old time iron wire—carefully galvanized with pure zinc, is used exclusively in "Pittsburgh Perfect" Fence. There are no wraps, clamps, twists or ties to increase weight, hold moisture and cause decay; instead, the wires at every contact point are

ELECTRICALLY WELDED

which produces a joint that cannot be slipped, pulled, broken nor rusted apart. There is a style and size of "Pittsburgh Perfect" Fence

For every FIELD, FARM, RANCH, LAWN or POULTRY purpose.

Write for catalogue showing 73 styles and sizes, or look up the best dealer in your town—he handles "Pittsburgh Perfect" Fence exclusively.

PITTSBURGH STEEL COMPANY, PITTSBURGH, PA.

Manufacturers of "Pittsburgh Perfect" Brands of Barbed Wire, Bright, Annealed and Galvanized Wire, Fence Staples, Standard Wire Nails and "Pittsburgh Perfect" Fencing.



## How Much Will You Take For Your Health?

\$100?—\$500?—No—you'd think I was crazy if I asked you to give it up for any money. Yet thousands of farmers are throwing away their health every day. You know that wet, chilled feet are absolutely dangerous. They are the cause of 90% of all diseases. You know that sooner or later they are bound to get you too—and once the results have got you they don't let go. Why not play safe by learning about Ruthstein's

**Steel Shoes**  
before you buy your working shoes. I absolutely guarantee that they are damp proof and the special insoles are practically cold proof. They are also lighter and easier on the feet than any other shoe you can buy, and one pair will outwear from three to six ordinary pair. Of course, there's too little profit in shoes that wear 2 years for dealers to keep them—so they knock my Steel Shoes. But over 500,000 satisfied farmers have already bought after seeing and trying the shoes themselves. Let me send you my free book telling all about how to take care of your feet, including a full description of my famous Steel Shoes. Write for it today.

**RUTHSTEIN**  
THE STEEL SHOE MAN  
164 7th St., Racine, Wis.

Get Free Book

**O K CHAMPION DIGGERS**  
Get all the Potatoes out of the ground in perfect condition. Our Two-Horse Elevator Digger saves time in your harvesting, and saves money on your own crop. We invite comparison with any others. Free Large Illustrated Catalogue giving particulars, prices, etc., of our full line of Planters, Sprayers, Diggers, etc., on request. Write today.

**CHAMPION POTATO MACHINERY CO.**  
199 Chicago Ave., Hammond, Ind.

**CORN HARVESTER** with Binder Attachment cuts and throws in piles on harvester or winnow. Man and horse cuts and shocks equal with a Corn Binder. Sold in every state. Price \$20 with Binder Attachment. S. O. MONTGOMERY, of Texaline, Tex., writes:—"The harvester has proven all you claim for it. With the assistance of one man cut and bound over 100 acres of Corn, Kafir Corn and Maize last year." Testimonials and catalog free, showing pictures of harvester. New Process Mfg. Co., Salina, Kan.



**Genasco**  
the Trinidad-Lake-Asphalt Roofing has the life that only *natural* asphalt can give roofing to lastingly resist all kinds of weather.

The Kant-leak Kleet clamps the roof-seams water-tight without cement, and prevents nail-leaks. Ask your dealer for Genasco with Kant-leak Kleets packed in the roll.

The Barber Asphalt Paving Company  
Largest producers of asphalt, and largest manufacturers of ready roofing in the world.  
Philadelphia  
New York San Francisco Chicago

## GARDENING

By T. GREINER

### Peonies and Ants

A LADY reader in Carnegie, Pennsylvania, reports that one of her peonies, a rather choice one given to her by a friend, is not doing well. It makes only half as much growth as another she has, and gives no bloom. Then she asks what to do for ants that seem to trouble both peonies. The peony is one of the easiest plants and flowers to raise. It succeeds on almost any kind of soil. But a strong clay subsoil, well drained, helps the bloom. What the trouble is with the one plant, I am, of course, not able to tell to a certainty. I imagine, however, that the ants are causing the mischief. Bisulphid of carbon is probably the best remedy. Punch a hole in the ground near the roots of the plant, a foot or more in depth, and into this pour a couple of table-spoonfuls of the drug; then quickly close the hole with earth. In some cases it may be better to dig up the plant, remove the soil to a depth of two feet, refill with a good soil-and-manure mixture, treat this with the bisulphid, and finally replant the peony, or get a new one.

### Some Insect Remedies

Some of the insect enemies of the rose and other shrubs can be successfully controlled, or the damage done by them greatly reduced, by simply directing a strong current of cold water (under high pressure if available) upon the affected portions of the bush. This will, for instance, be of some help against the scale insect known as "rose lecanium." In addition, the entomologist of the New York station at Geneva also recommends a strong solution of soap-suds made by dissolving one pound of common Ivory soap in eight gallons of water. And it may be said, also, that this same solution has proved of good service in fighting aphides, or common plant-lice, on all sorts of plants, vegetable as well as flowering. It will do no harm. You can use it freely and frequently.

### May Save Some Seed-Money

Many a nickel, many a dime may be saved by slight efforts in seed-saving. During winter, I repeatedly sow a bit of cress in the greenhouse, to be eaten with lettuce, etc., as a salad. I sow more in open ground in spring for the same purpose. I even raise cresses as a condiment and tonic for my little chicks and other baby fowls. A five-cent packet of seed does not go very far. It is easy to let a row or part row of this vegetable in the garden go to seed, and easy to gather the seed. When the ripe plants are pulled and exposed to the sun, and quite dry, the seed-vessels open easily, and the seed will fall out and can be gathered. This gives me a good supply for the purposes mentioned. I can sow it freely, more so than if I had to buy it in seedsmen's packets. This is only one instance of many. I usually gather what parsley-seed I wish to plant, also some parsnip and dill seed. If you let a single parsnip of last year's crop remain in the patch, or set it in some out-of-the-way spot in the garden, or allow one parsley to go to seed, it will produce all the seed that any family may wish to sow, and the seed is easily stripped off and put away. Thus we can and do gather salsify-seed by having a few plants of last year's crop left, or planted out. The home gardener better not save seed from melons where he grows more than one variety in his little patch. But if he visits a commercial melon-grower, and secures a fine specimen out of a patch of

one variety, he should save the seed of it for his own planting. Melon-seeds may simply be washed and dried in the sun. For saving cucumber-seeds, allow a fine specimen or two to remain on the vines; let it get dead ripe, on or off the vine, then open it, scrape out the seeds into a suitable dish and leave the whole mass of pulp and seeds to ferment. This will loosen the mucilaginous pulp from the seed so that the latter may be washed in plenty of water, letting the pulp float off the top, then drained and dried. Be sure to save your own squash and pumpkin seeds. Then you will not have to buy them another season. If you have a patch of really fine tomatoes, select the best plant, meaning the plant which produces the best, most uniform, well-colored specimens, and gather some specimens from it. Let them get fully ripe, squeeze the seeds out and let them ferment for a few days in their own juice or pulp. You can then free the seeds from the pulp by washing, floating the pulp off the top, and draining and drying the seeds. They dry quickly in the sun.

### Seed-Production in Nature

A Washington reader tells of his rhubarb-plants (which were grown from seed) giving fine leaf-stalks for two or three years, but since then apparently trying to spend their energies in sending up seed-stalks. That is only the natural course of events. Like most other plants, rhubarb wants to reproduce itself and to make seed. The gardener wants leaf-stalks, and for that reason always has a fight on hand for the suppression of that entirely natural tendency. In some seasons, when fruit is scarce in the fall, we have quite a little demand for rhubarb, and when the season for it is otherwise favorable, we often have very good stalks at that time. But we keep the seed-stalks pulled out as fast as they appear; otherwise we could not expect the plants to continue producing good, salable stalks. Sometimes the plants give out entirely in early fall. The heavy coat of manure put all over my patch last spring, and which yet covers the whole bed, keeps the plants nice and green and in good, producing shape. I have no use for the seed unless it might be from a single seed-head left growing on one of the best plants in the lot. I gather that in case I desire to grow a new lot of seedlings. Also, don't forget that the plants should be taken up every four or five years, and cut into pieces with at least one or two good eyes each for replanting.

## Garden and Orchard

### Setting Out the Home Orchard

A READER in southern Pennsylvania, preparatory to setting a home orchard, inquires the best time to plant peach-pits, depth and distance apart, also when to mulch fruit-trees, and best material; whether chip manure is good for the purpose; whether trees can be pruned in an old orchard safely any time after leaves fall, and if it will hurt to turn up an old orchard pretty close to the trees?

Peach-pits should be stratified in the fall (buried where they will keep moist, not wet, and receive action of frost). Crack pits not open in early spring and plant in nursery row two or three inches deep, one to two feet apart. Mulching should be done just before winter sets in after ground freezes in the North; any roughage or chip manure not infected with noxious weed-seed or fungus growths will do. Pruning may be done at any time while trees are dormant, but healing of the wounds will progress most rapidly when pruned just previous to starting of growth. Deep plowing among old trees will cause serious injury. Better cultivate shallow with cutaway harrow or disk. United States Department of Agriculture Bulletins Nos. 33, 161 and 208, on orchard fruits, will afford much assistance. B. F. W. T.

### Asparagus This Fall

WHAT kind of asparagus-plants to set out this fall to have asparagus next spring, is a query sent to FARM AND FIRESIDE.

It will not be possible to set asparagus-plants this fall with any degree of assurance that they will grow. Spring setting is considered far the most satisfactory.

It will be the best plan this fall to thoroughly prepare and fit the ground intended to be planted to asparagus, plowing or digging the ground to a depth of a foot, at least. This soil should be made very rich and the manure worked thoroughly through it, and in the spring, before the plants are set, another thorough working should be given it. Much depends on the selection of plants. A good, strong plant with but few well-developed buds and plenty of roots is better for the production of vigorous sprouts. One-year-old plants are preferable in the long run, although two or three year old plants may come into production of sprouts some-

what sooner. No crop can be gathered the first year and but very few of the sprouts should be dug the second year. The third year, and from then on, with proper handling, full crops can be secured. The roots should be set about six inches deep, in order that the after cultivation can be deep. B. F. W. T.

### Convenient Bins

IT is quite necessary to economize space in the cellar. If boxes are used for the storing of apples and potatoes, they have to be set one on top of the other, in order to utilize other than the ground space. This covers up different kinds of apples and often causes potatoes to rot by being too closely confined. If the boxes are deep, they are inconvenient to get into. Besides, the weight of the contents is often enough at the bottom of the box to injure the softer varieties of apples.

The illustration shows the end view of a convenient arrangement of potato and apple bins. Two-by-four scantlings are stood upright on the cellar-bottom and nailed to the girders above. Crosspieces of the same material, five feet eight inches long, are bolted or spiked perpendicular to them at convenient distances from one another. The bottom one should be placed about six inches from the floor and braced to prevent it from turning. The ones above are most convenient if put two feet apart. The upper crosspieces are tied to one another and to the bottom one by a cleat nailed along the ends.

On these crosspieces the floor of the bins are laid. Side-boards from eight to ten inches wide are set upon the floor and tacked to the two-by-four upright or to the cleat to hold them in place. This forms tiers of long bins on each side of the upright. To partition these bins off into the desired lengths, movable partitions are used. These are constructed from boards two inches wider than the side-boards by sawing out pieces which will fit between the side-boards and project one-and-one-half inches over their tops at either end. Through these projection nails are driven which will enter the top of the side-board about three eighths of an inch. About three inches from each end of the bottom of this partition nails are driven and their heads filed to a point to form spuds. When this partition is placed between the side-boards and tapped down, it will stay in place at any point along the bin. Bins made in this way are easily accessible, light, dry and saving of the cellar space. MONROE CONKLIN, JR.

### The Downy Woodpecker

DOWNY woodpeckers are the most valuable birds in our orchard, here in Washington State, and we have tried many ways to get them to nest either in or close by the fruit-trees. One of the most effective means of enticing the woodpeckers to our ranch was devised by a member of the family. The same plan can be tried by other orchardists who would like to attract woodpeckers to their trees. We went down to the river where there are groves of cottonwood and cut down all the dead trees which had been pecked full of holes by past generations of woodpeckers. These trees were chopped and let fall easily by means of ropes to prevent

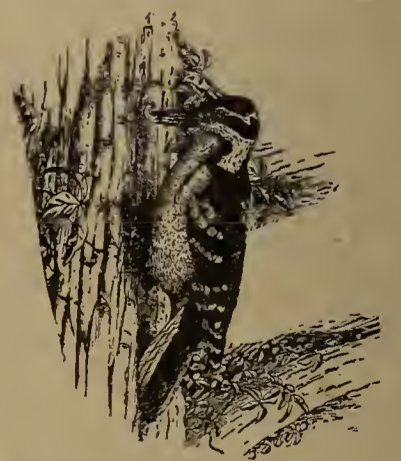

**Wheat and Clover**  
Many farmers stick to wheat raising mainly because clover follows it in the rotation. But why not get the best possible out of both crops? No crop returns better profit for the right fertilizer than wheat. What is the right fertilizer? That depends on the soil and on what fertilizer you have used on it. The longer you have used phosphate the sooner it will pay you to balance it with

**POTASH**

Insist on your wheat fertilizer containing 6 to 8 per cent. of Potash. Potash Pays on both wheat and clover.

If your dealer does not carry Potash, write us for prices, naming quantity needed, and ask for our free books, "Fall Fertilizers" and "Home Mixing." They will show you how to save money and increase profits.

**GERMAN KALI WORKS, Inc.**  
Baltimore: Continental Bldg.  
Chicago: Monadnock Block  
New Orleans: Whitney Central Bank Bldg.

# Farm Notes

## Cornering the Dollar

GIVEN a location convenient to a city or village, the problem of bringing home the consumer's whole dollar instead of the usual thirty cents may be boiled down to a satisfactory answer in two words: **SELL DIRECT.**

Our farm is about two miles from a city of 25,000 and one mile from a village of 1,500 inhabitants. Our work is to produce the goods, take them to the consumer and listen to his dollar as it goes jingling into our pockets. The hardest thing we have yet met is a shortage in some lines of goods. For instance, we have on our list customers for butter, eggs, buttermilk, etc., far in excess of what we are as yet able to supply. Our plan in the beginning—and we are still at it—was simply this: During the seasons of vegetables, fruits, etc., we have a wagon on the road every week-day. We aim to have our stock as nearly complete for the season as possible. In the beginning, disposing of each load was a simple case of peddle, peddle everywhere, from door to door. We did no street-crying. We decided "when you try to sell from the street, the majority of the people remain so far from your wagon as to be unable to see what you have and you don't sell it," and we still believe this.

Having good stock and fresh, it required but a few stops at any one house to win that family over to the "permanent" side in our list of customers. Wherever we went, we literally "swamped" our competitors, the city hucksters. In the village it was still easier, as we knew the people and were known by them.

In winter we make deliveries on Tuesdays and Fridays of goods ordered in advance, thereby avoiding special trips. The telephone is our assistant in this line, and we find it a very efficient and economical assistant, too. Sales during this season consist principally of butter, eggs, buttermilk, dressed poultry, potatoes, onions, turnips and carrots.

We have a separator, and realized long ago that skim-milk not fed to young stock, sold at four cents per quart delivered, is just as good so far as money goes as wholesaling whole milk at the same figure, and we have the butter and buttermilk besides. The increasing demand for skim-milk and buttermilk is gratifying. We consider them as by-products, but the receipts from them buy nearly all the feed we need for our stock, and receipts from butter is therefore nearly clear profit.

The majority of farmers in this vicinity sell their produce to the stores. Having been actively engaged in the store business ourselves, before taking up farming, we knew that dealing with storekeepers in this manner meant giving them the profit on our goods as well as paying them a profit on goods we bought of them. Consequently we kept away from them and incidentally kept our profits, too.

Another thing upon which we congratulate ourselves is our method of keeping accounts.

5-	12 1/2 @ 34¢	\$ 4.08
7-	11 " " "	3.78
10-	14 " " "	4.76
13-	14 " " "	4.76
21-	15 " " "	5.10
23-	14 " " "	4.76
25-	18 " " "	6.12
28-	15 " " "	5.10
	113	\$ 38.42

Butter	\$ 38.42
Buttermilk	2.54
Eggs	19.74
Poultry - live	7.25
Skimmed Milk	2.08
	\$ 70.03

Two of the cards from the index—each is 3x5 inches. The cards fit in a neat box

We use the card-index system and find it works better than any other we have tried—and we have tried several. In summer we supplement it with small, cheap books on the wagon, transferring sales to the index each night. In the index system we have neatly arranged in alphabetical order our list of active customers, "waiting" customers (those whom we are as yet unable to supply) in the order in which they applied, separate headings for each article produced for sale and the sales of each separately, monthly totals of articles produced and monthly sales of each separately and collectively, and finally a separate heading for closed accounts.

By this method we are able to tell in a few seconds how each item has done for the month and can tell with very little trouble how each month compares with the same

month of the preceding year. An accurate account is also kept of all expenses which may be charged up to the farm.

Of course, there is a bit of work attached to a method of this kind, but the satisfaction of knowing just where we are every day more than compensates for the work.

With a number of other systems a man may become gray and stoop-shouldered trying to figure what he did last year—and probably discover in the end that he is no more than half right and not sure about it even then. With our plan of writing up each day's business as we go along, totaling months and years, we KNOW we are right and it takes but a short time to find the answer. Guesswork—one of the banes of farming—is eliminated. E. A. ELLSWORTH.

## A Good Well

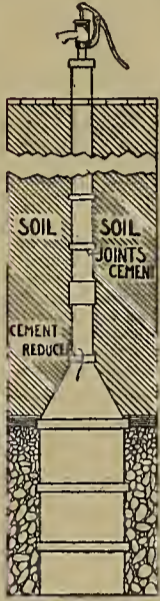

IN BEHALF of good, clean water, which is so very essential to life and health, I submit drawings of a well wall which has been tried and found to be the best. Where redwood boards were used for well curbing, the water became black and sour, certainly a very unsatisfactory condition. The next best and cheapest walling material obtained was glazed sewer-pipe. I used the two-foot size as far as the water would rise, or, say, four joints, then I placed a cement reducer, which I had made to fit on the big tile and reduced to the hub of a six-inch tile, first joint of the six-inch hub being down. I now filled clean boulders around the big tile as loosely as possible to its top, using fine rock on top and a final layer of cement mortar. Then I began filling back the dirt, with a cement double hub made at the same time as the reducer. I inverted the six-inch tile so that the big end was up. Each joint was thoroughly cemented and the earth packed well around. A plumb-bob was used and the work kept straight. The six-inch tile ran two feet above ground, and we sloped the soil away from the well brick. Good stone or cement blocks can be used instead of the two-foot tile, if they can be had. Reinforce the tile above ground if the well is deep or in a stock-yard. A six-inch tile will let foot and cylinder through if kept straight. JAS. H. PAYNER.

## Shaling Sand Roads

THE eastern part of Jackson County, Wisconsin, includes some rather light, sandy soil, and the question of good roads has been a serious problem to the people of that section for years.

Recently, it has been discovered that the ridges, or bluffs, of that locality contain a species of shale rock, which, under travel and exposure to the elements, crumbles and packs to form an ideal road-bed. Following this discovery, shale-pits have been opened at various convenient points, and the roads are being "shaled" as fast as money for the work can be raised by the town included in the sand-belt.

In some towns taxpayers of the town do the shale-hauling at a fixed rate. Other towns let out the work by contract to the lowest bidder. Some donated work is done by those most interested in securing good roads.

The more difficult stretches of sand road are being put in fine condition at an average cost of about two dollars per lineal rod.

GERTRUDE K. LAMBERT.

## Fence-Posts Ought To Last

A WASHINGTON reader desires to know what to put on fence-posts to keep them from rotting just above the ground, stating that they are good under the ground, but not above.

It has been found that if the timber has been thoroughly seasoned during the spring and summer following its cutting in the fall or winter, during the time when the wood is dormant, the treatment will be more effective.

The only preservatives now commonly used are creosote and zinc chloride. The posts or holes are either treated by painting with the preservative, heated to the boiling-point, or by means of what is called the "open-tank" treatment.

The painting treatment consists of painting thoroughly seasoned wood with one of these preservatives heated to the boiling-point, giving two or three coats, taking care to have every knot-hole filled with the preservative.

The hot open-tank treatment consists in placing posts in the preservative, which is kept at a temperature of about 212 to 220 degrees Fahrenheit, for from three to four hours.

It has been found that by the treatment in the open tank the life of the post or pole is about double that of the untreated ones.

The cost of the creosote is given at eight cents per gallon in bulletins issued by the Forest Service, which describes these treatments. B. F. W. T.



## Farmers' Rubber Boots

Rubber boots to the farmer are a matter of prime importance. They are a part of his necessary equipment. He wants boots that will be easy and comfortable and will stand the hardest kind of service. Here are just the boots:

### The Elephant Head Boots

A fine new brand of a famous old company. The Woonsocket Rubber Company is the best-known rubber boot company in the world. For 40 years the Woonsocket boot has led all others. The latest and best Woonsocket product is the Elephant Head brand, made in all styles of boots—and shoes, too.

Ask for **Woonsocket Rubber Co.'s** Look for the  
the **Elephant Head Brand** Trade-Mark.

WOONSOCKET RUBBER CO., Woonsocket, R. I.

## Reliable BLIZZARD Ensilage Cutter Always Works Right

Send for New Catalog Illustrated.

You can cut any dry or green feed most economically, shred corn to best advantage, if you own the **Blizzard**. Designed to stand hard service without a bit of strain or pull and built in fewest parts—simple, easy running, with self-feed table and knives adjustable while running.

**We Guarantee It Fully**

Improved Wind Elevator carries fodder any height, any direction. Every machine tested separately before shipping. A demonstrated success for 38 years. Shipped ready to put up. Let us send you free book, "Why Silage Pays." Write today.

**JOS. DICK MFG. CO.**  
1444 W. Tuscarawas St. Canton, Ohio

## Wanted—Local Club Agents

FARM AND FIRESIDE desires a local representative in every farm community who will devote a portion of his time to looking after renewals and new subscriptions. The work is pleasant and you will receive either Cash Commission or Valuable Premiums. Write to

**FARM AND FIRESIDE**  
Club-Raisers' Department Springfield, Ohio

## DAIN—THE ONLY PULL POWER HAY PRESS

Remarkable invention. This pull power principle overcomes all of the disadvantages of other hay presses and gives the Dain every advantage you know a hay press should have. You will recognize these advantages when you investigate. Dain Pull Power—saves one man on the stack—discharges bales forward out of way—is lighter in draft—with no bulky pitman to step over—self-feed cuts feeding work in two. Don't buy a hay press until you learn all about the Dain. Send for big hay press catalog—it's worth sending for whether you buy a hay press this year or not.

**DAIN MFG. CO.**  
860 Vine St., Ottumwa, Iowa

## LIGHTNING HAY PRESSES

Tested for over 25 years. Made in many styles, Horse Power, Belt Power and Self-feed Attachment. Simple and Durable with Greatest Capacity. They make a Profitable Investment. We can suit you. Write for Catalog and Prices.

**KANSAS CITY HAY PRESS CO.** 124 Mill St., Kansas City, Mo.

## Don't Guess—Be Sure When You Sell

Keep in touch with your market by telephone. It is the surest, quickest way to get highest prices for your product.

**But be sure your telephone is a Western Electric Rural Telephone**

—the kind you can always depend upon. Made by the largest and oldest telephone manufacturers in the world. Specially designed for rural service.

Mail coupon to nearest house for book giving reasons why a Western Electric Telephone is the best investment.

The Western Electric Company Furnishes Equipment for Every Electrical Need.

**WESTERN ELECTRIC COMPANY**

Manufacturers of the 5,000,000 "Bell" Telephones

EVERY BELL TELEPHONE IS A WESTERN ELECTRIC TELEPHONE

New York	Chicago	Saint Louis	San Francisco
Buffalo	Indianapolis	Kansas City	Oakland
Philadelphia	Cincinnati	Denver	Los Angeles
Boston	Minneapolis	Dallas	Seattle
Pittsburg	St. Paul	Omaha	Salt Lake City
Atlanta	Milwaukee	Oklahoma City	Portland
Montreal	Toronto	Winnipeg	Vancouver
London	Paris	Antwerp	Berlin
Johannesburg	Sydney	Tokyo	

SAVE TIME AND FREIGHT

YOUR NAME AND ADDRESS WRITTEN IN THIS SPACE AND MAILED TO OUR NEAREST HOUSE WILL BRING COMPLETE INFORMATION

Booklet No. 50

Name Address



**White Lead on the Farm**  
*For Houses*

Paint your house when it needs it and use the best paint—that is the whole story of paint economy. The longer you put off painting the more paint will be required. Paint made of

**"Dutch Boy Painter"**  
*Pure White Lead*

and pure linseed oil is the most economical paint in the world because it is the most durable. It holds to the wood like a nail and protects the surface perfectly against the attacks of the weather.

**Our Free Painting Helps**

We will send you free on request color schemes and miscellaneous painting instructions that you will find of real practical value. Ask for Helps 1147

**NATIONAL LEAD CO.**

New York Cleveland Chicago St. Louis  
Boston Buffalo Cincinnati San Francisco  
(John T. Lewis & Bros. Co., Philadelphia)  
(National Lead & Oil Co., Pittsburgh)



**Crops and Soils**

**Alfalfa in Rotation**

**I**N a rotation where it seemed desirable to replace clover with alfalfa, a six-year rotation would be, to my mind, about the most practical. This need not necessarily involve six fenced fields, but would suggest the wisdom of six measured fields of about equal size.

Let one of these fields be seeded down each year to alfalfa with barley as a nurse crop. Let one sod-field be plowed the first year and one field the second year, for corn. The remaining three fields will be cut over for alfalfa. This arrangement gives one sixth in small grain, two sixths in corn, or one third as in the three-year rotation, and three sixths, or one half, in alfalfa. Now, in the event that one wished to bring up one field to alfalfa fertility or drain, I would suggest that that field be farmed in the three-year rotation, but all in corn, all in wheat, or all in clover. We cannot multiply fences and fields too much without both expense and waste.

A few years ago, I felt considerable impatience with the farmers here in the humid lands who did not take hold of alfalfa faster. I am a little older now, if not a little wiser,

and I have a little more charitable feeling. Our farmers are taking hold, if slowly, very surely, in spite of the fact that labor is so hard to secure in caring for the alfalfa after they get it. I know that they will have something when they do get it. And that it will pay them even under such handicaps as farmers are now placed. WILLIS O. WING.



This picture was taken June 25, 1911. The scene is near Mountain Grove, Missouri, where between May 1st and July 10th only two inches of rain fell. It was necessary to conserve moisture. In this case the cultivation was done with a two-horse, eight-shovel, spring-tooth cultivator, until the last cultivation, when the spring teeth were transferred to an A-shaped frame made on the farm. This illustration shows one mule pulling this home-made device for saving soil-moisture

**Lifting Heavy Hay-Racks**

**A** TENNESSEE farmer says he is tired of lifting heavy hay-racks, and asks for relief. One solution of this tiresome job is to arrange four ropes or wires provided with hooks, one for each corner of rack; these to fasten to a rope running over a pulley in the loft of shed or storage building, and thence to a windlass where a few turns of the crank will elevate or lower the rack without effort. He suggests a rack made in two parts, but the pulley and windlass appear preferable. In the Headwork Shop, January 10, 1911, we published another plan that may be still more helpful, at least for some kinds of racks. B. F. W. T.

A trade-mark is a design or device used by manufacturers to distinguish their goods—"by this sign you may know them." Do you realize what it means? The manufacturer makes up this design or figure and sends it to Washington, paying a fee to have it registered. Thus it is his property and no one else may use it. Do you ask why all this expense and trouble? Is not one class of goods as good as another? Not by any means. The manufacturer who trade-marks his products is proud of them. When you buy his goods of your local dealer and are pleased with them (which he nearly always guarantees), he wants you to go back and get more of them, which you can always do by calling for them by name or by the trade-mark. Thus a trade-mark is a sign of quality—of satisfaction.

It is reported that a large soap manufacturer recently said he would not take ten million dollars for his trade-mark. Rather proud of it, don't you think? He ought to be, because it stands for good goods at fair prices.

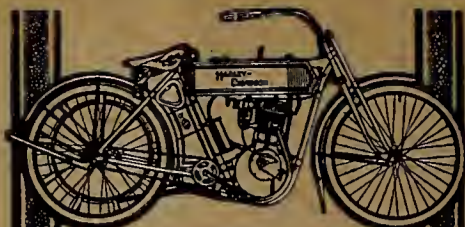

**10 Miles for a Cent**

You can go to town in one-fifth the time, with twice the pleasure and at one-tenth the cost on a

**Harley-Davidson**  
**MOTORCYCLE**

**It is the Most Economical**  
The Harley-Davidson holds the official World's record for economy.

**It is the Most Durable**  
The first Harley-Davidson we made nine years ago although they have traveled thousands of miles are still giving perfect satisfaction.

**It is the Most Reliable**  
The Harley-Davidson is the only motorcycle that has ever been awarded a diamond medal and a 1000+5 score for super-excellent performance in an endurance contest.

Nearly one-third of all the motorcycles sold in America are Harley-Davidsons.

Let us tell you more about the "Silent Gray Fellow."  
**HARLEY-DAVIDSON MOTOR CO.**  
812 L St. Milwaukee, Wis.

**Rider Agents Wanted**

in each town to ride and exhibit sample 1912 bicycle. Write for special offer.  
Finest Guaranteed 1912 Models \$10 to \$27 with Coaster-Brakes and Puncture-Proof tires. 1910 & 1911 Models \$7 to \$12 all of best makes.  
**100 Second-Hand Wheels** All makes and models, \$3 to \$8 good as new.  
**Great FACTORY CLEARING SALE** We Ship on Approval without a cent deposit, pay the freight, and allow **10 DAYS' FREE TRIAL.** TIRES, coaster brake rear wheels, lamps, sundries, parts and repairs for all makes of bicycles at half usual prices. **DO NOT BUY** until you get our catalogues and offer. Write now.  
**MEAD CYCLE CO., Dept. F.88, CHICAGO**

**FREE** Literature will be sent to anyone interested in the wonderful Sacramento Valley, the richest valley in the world. Unlimited opportunities. Thousands of acres available at right prices. The place for the man wanting a home in the finest climate on earth. No lands for sale: organized to give reliable information. Sacramento Valley Development Association. SACRAMENTO, **California**

**LEARN TO WRITE ADVERTISEMENTS EARN \$25 to \$100 A WEEK**  
We can positively show you by mail HOW TO INCREASE YOUR SALARY. Book mailed free. Page-Davis, Dept. 25, Chicago Ill.

**PATENT** SECURED OR FEE RETURNED. Free Patent Book, Selling Guide and List of Buyers and Manufacturers of Inventions. Advice Free. Send sketch. **FARNHAM & SUES, Attys., 562 F. St., Washington, D. C.**  
**PATENTS** Send sketch or model for **FREE SEARCH.** Books, Advice, Searches and **FREE** Big List of Inventions Wanted **FREE** Watson E. Coleman, Patent Lawyer, Washington, D. C.

**Twelve Fortune-Telling Post-Cards**  
**All for the Asking**  
**ONE** for each month in the year with horoscope of persons born in that month. You and your friends will get lots of fun and entertainment out of these cards. Simply send three two-cent stamps to pay the postage in mailing. We make you this unusual offer simply to get acquainted with others who appreciate post-cards; and just as soon as we receive your letter we will tell you how to get a set of.  
**Fifty Magnificent Post-Cards**  
all postage and mailing expenses paid. Send three two-cent stamps right away, as our supply of these cards is limited, but we guarantee a set of these new Fortune-Telling cards by return mail if you write us at once.  
**Farm and Fireside**  
Springfield, Ohio

**EMPIRE FENCE**  
Get the genuine EMPIRE big wire fence, direct, at wholesale. Save dealer's profits.  
**Big Factory, Big Sales, 23 Styles**  
No traveling salesmen, small expense, prices low. Everything guaranteed. Free samples by mail. Prices of leading styles freight prepaid to all points north of the Ohio and east of the Mississippi River.  
Wires Inches high Medium Weight Extra heavy (All No.9)  
9 39 23c per rod 37c per rod  
10 47 26c per rod 41c per rod  
12 55 32c per rod 49c per rod  
Special rates beyond this territory.  
**BOND STEEL POST CO., 42 E. Maumee St., Adrian, Mich.**

**SALESMEN WANTED**  
Trained Salesmen earn from \$1,200.00 to \$10,000.00 a year and expenses. Hundreds of good positions now open. No experience needed to get one of them. We will assist you to secure a position where you can get Practical Experience as a Salesman and earn a good salary while you are learning. Write today for full particulars, list of good positions we now have open and testimonials from hundreds of men recently placed in good positions.  
Address Nearest Office, Dept. 184  
**National Salesmen's Training Association**  
Chicago New York Kansas City Seattle New Orleans

**HARVEY BOLSTER SPRINGS**  
Soon save their cost. Make every wagon a spring wagon, therefore fruit, vegetables, eggs, etc., bring more money. Ask for special proposition. Harvey Spring Co., 729-17th St., Eureka, Wis.  
**GUARANTEED**

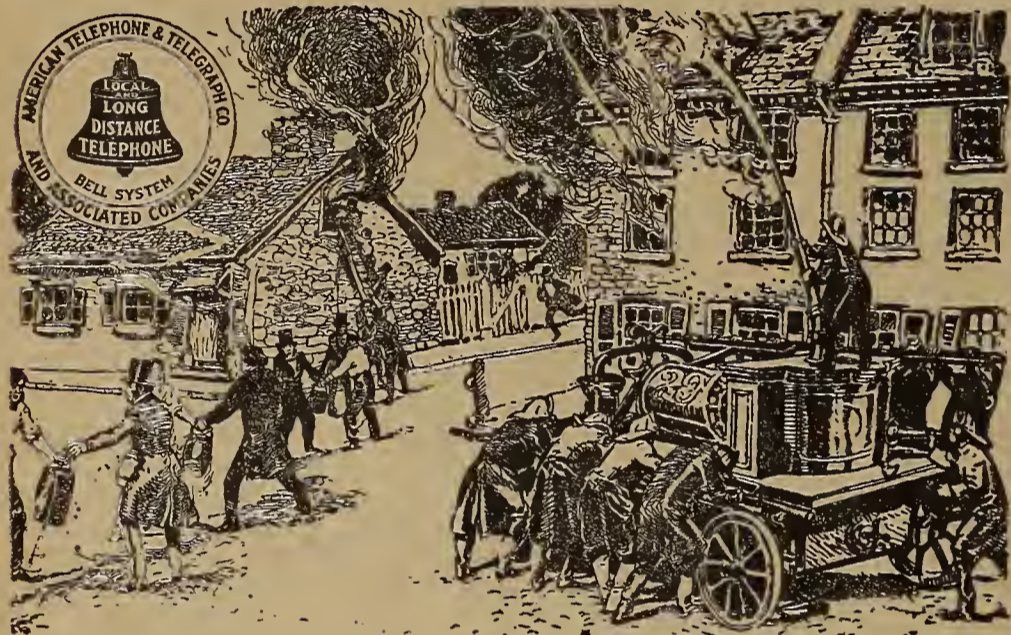

**Fire Fighting and Telephoning**

**Both Need Team Work, Modern Tools and an Ever Ready Plant, Everywhere**

Twenty men with twenty buckets can put out a small fire if each man works by himself.

If twenty men form a line and pass the buckets from hand to hand, they can put out a larger fire. But the same twenty men on the brakes of a "hand tub" can force a continuous stream of water through a pipe so fast that the bucket brigade seems futile by comparison.

The modern firefighter has gone away beyond the "hand tub." Mechanics build a steam fire engine, miners dig coal to feed it, workmen build reservoirs and lay pipes so that each nozzleman and engineer is worth a score of the old-fashioned firefighters.

The big tasks of today require not only team work, but also modern tools and a vast system of supply and distribution.

The Bell telephone system is an example of co-operation between 75,000 stockholders, 120,000 employees and six million subscribers.

But to team work is added an up-to-date plant. Years of time and hundreds of millions of money have been put into the tools of the trade; into the building of a nation-wide network of lines, into the training of men and the working out of methods. The result is the Bell system of today—a union of men, money and machinery, to provide universal telephone service for ninety million people.

**AMERICAN TELEPHONE AND TELEGRAPH COMPANY**  
**AND ASSOCIATED COMPANIES**

**One Policy One System Universal Service**

**CASH OR CREDIT** **Catalogue FREE.** **ONLY \$10.00**  
Cash, balance \$5 per month, buys this 3-year-guaranteed buggy. Buggies \$29.50 up; Surries \$45.00 up; Farm Wagons \$40.00 up. We trust honest people located in all parts of the world.  
**Write For FREE CATALOGUE.**  
**Century Manufacturing Co.,**  
Dep't 574 East St. Louis, Ill.



# The FARMERS' LOBBY.

## Vacations in Alaska

By Judson C. Welliver

Congress from Alaska has charged that he submitted to the Department of Justice the proof of criminal performances by the representatives of the Alaska Syndicate; that no attention was paid, no prosecutions begun; that after waiting more than a year—that is, until the statute of limitations had run against the alleged offenses—the attorney-general replied that it was impossible to prosecute! Of course it was, when the immunity shower had been turned on by Father Time.

### "We'll See What's Wrong"

WELL, anyhow, this committee on judiciary has twenty-two members. Added to the fifty-two already listed, we have seventy-four investigators working on Alaska.

Most of the Alaska legislation is referred to the committees on public lands. The House committee on public lands has twenty-two members, and the Senate committee on public lands has fifteen. Add these thirty-seven to the seventy-four already indicated as special guardians of our Alaska heritage—that's the word the high-browed boys use now when they are talking about Alaska—and you have one hundred and eleven S. G.'s. Alaska ought to be thoroughly policed.

It is my guess that this Alaska business will be a vastly more important affair, in the mind of the American public, before it is forgotten. For two years the opposition to President Taft—Republican opposition at that—has been proclaiming that if it could get to the bottom of his relations with the people who seek control of Alaska, it would capture the most valuable magazine of political munitions that could possibly be opened for the purposes of an anti-Taft campaign. Now the anti-Taft people claim that they have got hold of a string that promises to unravel the entire tangle, and they are pulling hard. If they don't break the string in their excitement, or further complicate the tangle, they seem likely to get important results.

The charge is that the Guggenheim Alaska syndicate is trying to get control of the coal and copper deposits of Alaska. They built the Copper River and Northwestern Railroad to open these riches, intending to use Cordova Bay as their ocean terminal. Later, they discovered that Controller Bay was a possible terminal. If a rival concern should get Controller Bay, it might tap the same coal-fields, and thus prevent a monopoly of the transportation, and transportation, according to all the authorities, is likely to control the coal. So, according to this theory, the Guggenheims wanted Controller Bay and its excellent harbor.

But the lands fronting on Controller Bay were not subject to entry or sale because they were included within the Chugach Forest Reserve. President Roosevelt had extended the reserve to include them, because he was distrustful of all Alaska operations in public lands, and had a premonition that somebody would want them for terminal purposes. The problem was to undo this act of Roosevelt; to get Taft to take the lands out of the reserve, restore them to the body of the public domain, and make them subject to entry once more.

For this purpose, application was made in the name of the Controller Bay Railway and Navigation Company to have the lands taken out of the reserve. This company claimed to be independent of the Guggenheim interest. President Taft was apparently anxious to know. Richard S. Ryan, its president, was in Washington, a year ago now, lobbying to get these lands.

### Stories Don't Jibe

IT is declared that Ryan, following a conference with the President, wrote a letter to Secretary Ballinger, saying that he (Ryan) had talked with the President; the President wanted to know whom Ryan really represented; Ryan sent for Charles P. Taft, and got him to tell the President who Ryan's backers really were; and that thereafter the President withdrew his objections to Ryan's claims.

The first question is, "Did Ryan write this letter?" It is not now in the Interior Department files. The officials there say they do not believe it ever was. But Miss Mabel F. Abbott, a magazine writer and investigator, says that she saw it there a few weeks ago when the files were shown her by order of Secretary Fisher. If it were there, it strongly suggests that the President's brother induced him to give Ryan the lands.

Anyhow, on October 28, 1910, a little more than three months after the date of this alleged letter of Ryan to Ballinger, the President did issue an executive order withdrawing from the Chugach reserve the very lands Ryan had asked, and opening them to general entry.

It is charged that Ryan "soonered" the proposition; that is, that having a promise from the President to open the lands, he hurried off to Alaska and surveyed out the particular pieces he wanted, and rushed his plat and notes back to Washington, to show just what he was taking. Right at this point comes the crux. Ryan had no right going upon these lands and surveying off the choice bits he wanted, until the government surveyors had first made THEIR survey of the whole tract. So, it is charged, Ryan made his survey AHEAD of the government survey, and then hurried it to Washington, filed it after the government survey had been filed, and telegraphed his associates in Alaska to make their entries at once, before somebody else should "beat them to it."

They did just that.

Here comes the strange part. The records show that the government survey was finished December 1st. The Ryan survey and plat must be prepared entirely AFTER the government survey was finished. Yet the Ryan plat was received and filed at the War Department, in Washington, thirteen days after the date on which the government survey was finished. It is declared by people who ought to know that it is a physical impossibility to make such time between Controller Bay and Washington. They declare that the Ryan survey must have been made BEFORE the government survey; that Ryan was able to anticipate, because he had the President's promise to withdraw the lands; that Ryan made his survey AHEAD of the government survey, but in filing it dated it as of December 14th—thirteen days AFTER the completion of the government survey.

There is the story about the pre-dated survey. The map showing this survey, dated December 14th, was filed at the War Department, and there Miss Abbott saw it. She sent Gifford Pinchot to see it, so as to have a good witness. He says he DID see it.

### The Democrats Are Awake

BUT when, on July 15th of this year, the congressional investigators sent for all maps and plats of that region, the officer bringing them from the War Department did not bring this particular plat. He said it had never been brought there or filed.

Miss Abbott said it had. Pinchot said it had.

It was a case parallel to that of the Ryan letter to Ballinger. If the map could be produced, it would show collusion. But in each case the incriminating document itself is gone. Were they removed from the department files by people who knew that, if found there, they would prove the charges that have been made?

That is the question which the congressional investigators are trying to answer. The House committee on expenditures in the Interior Department is running one line of inquiry; the House committee on judiciary is running another. The delegate from Alaska, Mr. Wickersham, makes bold and direct charges against the administration. He charges that more than a year ago he placed in the hands of the attorney-general information on which prosecutions for fraud should have been instituted against agents of the Guggenheim syndicate; that these prosecutions were not begun, and that the statute of limitation was allowed to run against prosecution before any move was made; then, and only then, he says, he was notified that no action could be taken in the matters complained of.

On the other hand, the attorney-general replies to this charge by declaring that he has neglected nothing. The whole affair is a mass of assertion and contradiction.

The Democrats are making the most of their opportunity. They are getting together their campaign material for 1912. They propose to charge that Republican administration has been administration in behalf of powerful private interests, and that the only way to know how far it has gone is to give the Democrats a chance to come in and "examine the books." Everybody whose recollection dates back so far as the first Cleveland campaign will remember how strongly that slogan was employed then, and how effective it was.

Likewise, everybody will remember that, when the investigation came to be made by the victorious Democrats, they fell a long way short of proving even in a suggestive way any of the things they had so confidently claimed they would show.

THE mercury standing at ninety-eight in my room as I write, and being five degrees higher outside, surely nobody will have the heart to object if I indite a few thoughts about Alaska. Meteorologically, it's nice to contemplate, during this weather, a region where the mercury breaks the tube at the bottom instead of the top.

Speaking of the weather, did it ever occur to you what a splendid thing it is to serve a country that extends from Arctics to tropics, from coldest to hottest? It's fine to serve the government as a scientist, as some are doing in this Alaskan country.

If you're a government scientist, there will be need in summer to investigate the flora of the Maine woods or the forestation of Yellowstone Park. You'll likely be put to the discomfort of camping out, catching your own mess of bass in the morning, sleeping in a tent and doing all the things that you'd give your nigh lung to do if you weren't a scientist, but that constitute the daily drudgery of a wearisome scientific career in the government service. If you're a geologist, you just feel compelled to study Montana, Colorado and Alaska in summer, while in winter you are irresistibly drawn to the wonder-regions of Arizona, New Mexico and California.

Last session, for instance, Congress established a joint committee to visit Alaska this summer. It will go as soon as possible after Congress adjourns. Nice, comfortable government boat; plenty of good company; fishing fine, game laws not working, mercury under complete control; icebergs now and then floating past. Doesn't it sound as if you could sacrifice yourself quite a bit, that way?

Anyhow, as soon as this joint committee's trip was provided for, the Senate committee on territories got the idea that it, too, ought to study Alaska—and watch the joint committee. So Senator Smith, of Michigan, chairman of the territories committee, introduced a resolution directing his committee to study Alaska during the recess. It promptly passed. Another nice, cooling junket. Government pays the bills, of course.

### Wickersham Wants Everybody To Go

WELL, Judge "Jim" Wickersham, delegate from Alaska, seeing a chance to swell the population and get a boom census, thought, while the investigation was afoot, there might as well be a-plenty of it. So he introduced a resolution, providing that the House committee on territories, also, should visit Alaska during the interim between the special session and the regular one next winter.

That makes one special joint and two regular standing committees to visit Alaska this summer with Uncle Sam giving down the expense coin. Secretary Fisher saw, and approved. The Senate committee could watch the joint committee, the House committee could watch the Senate committee, they could all watch the wicked Guggenheims, and—happy thought!—why shouldn't he chase along up, too; get a nice, cooling trip, and watch the whole lot of 'em?

No sooner thought than decided. The secretary will go, too. Altogether, there are twelve members of the Senate committee, twenty of the House committee and twelve of the joint body: forty-five little statesmen, all in a row, including the secretary.

Interesting coincidence right here. I learn, by report, whose authenticity it has been impossible absolutely to test, that just a trifle more than two scores of fine, modern fishing-tackle outfits have been disposed of recently to public men who expect to have business in the far north this season. I didn't investigate the report; hoped it was true, for, on the basis of past performances, a congressional investigating committee in Alaska is doing about its best service when it's fishing.

We have counted up forty-five people now sleuthing through the wilds of the northwestern empire. But they are only the beginning. The House Committee on Expenditures in the Interior Department is holding daily sessions in the effort to discover who it is that's at the bottom of the alleged efforts to hand all Alaska over to the Guggenheim syndicate. There are seven members of this committee, which brings the total up to fifty-two.

But still the list is not completed. The House committee on judiciary is sitting day by day—and getting column after column of sensational "stuff" in the newspapers—in the effort to decide why the laws are not enforced in Alaska as elsewhere. The member of

# Things Worth Knowing About

## "Stuffing" Things

By Crittenden Marriott

PERHAPS the last time you visited an art museum you stopped and looked at some of the large animals on exhibition, and the thought may idly have come to you that they appeared marvelously lifelike. But did it occur to you to question how this wonderful work of stuffing the animals was accomplished? In this day we take so many things for granted that you may not have looked beyond the fact that there was a perfect representation of some king of the jungle, almost as alive as when he faced his trappers in an African forest.

Of course, it goes without saying every boy and man has "stuffed" something, either a rabbit, a wild duck, a squirrel or a cat or, alas, a favorite puppy, which has met with some misadventure and gone where good bow-wows go.

But whatever has been the animal, it is safe to say that the work of stuffing never turned out successfully. It is simply impossible for even the cleverest person to succeed at a first attempt—and there are very few that have the perseverance to make the second, after they have seen the woeful effects of the first.

It is not at all surprising that failure results from the efforts of the average person to mount an animal. Taxidermy is a very difficult trade, and has to be learned by long and hard practice. Even experts often find it almost impossible to give a lifelike pose to their creations, no matter how skillful they may be.

Not long ago a famous workman, who wished to mount a giraffe, traveled all over the United States, visiting various circuses, for the sole purpose of studying different living giraffes, so as to get ideas which he might use in building a skeleton to fit the particular skin intrusted to him. He finally succeeded in stuffing the giraffe, and critics who saw the finished work declared that it was perfect. So you see what a great deal of perseverance and patience are required to be a successful taxidermist.

Notice any living animal and see how its skin stretches and shrinks automatically as it changes its position. In one attitude some of its bones stand out very prominently; in another, these disappear and their places are taken by an entirely different set of protuberances; the skin that hangs so loosely on a tiger when he stands facing you is stretched tight when he takes another attitude. Yet the skin is the same in all cases.

When this skin comes into the hands of the taxidermist, it is little or no guide to the appearance of the animal to which it once belonged. You can't simply sew the cut places up and stuff it with cotton (as most people try to do and which seems to be the easiest way out of such a task) and get any satisfactory result. No live animal ever had all its skin stretched at the same time, as such a stuffed figure would have. Nor can you (unless you obtained very accurate measurements from the animal while alive, or from its body when dead before skinning) construct a rigid frame that will come anywhere near to being satisfactory when the skin is drawn over it.

As a matter of fact, all mounted animals are built up, either of wood and excelsior or of plaster of paris. When they are small and their anatomy is well known, they may be molded in the latter and then pared down where too large. But if large, the method is that shown in the illustrations on this page.

Figure 1 shows the skeleton of wood and iron, wrapped with excelsior, which serves as basis for mounting the elephant which now stands complete in the hall of the National Museum at Washington. None of the actual animal is used in the construction of this skeleton, except the tusks and a part of the bony structure of the head.

Figure 2 shows the elephant with the skin thrown over the hollow sides. Experts then go over it and stuff it out to its proper proportions with excelsior. As each part is properly stuffed, it is tacked down by long pin-like nails which prevent any more excelsior being forced up past them, and, therefore, prevent the skin from bulging unduly, as it would, of course, if the workmen kept on forcing the excelsior through the slits in the skin.

After all the "stuffing" is in, the animal must be strapped down and left to dry. Of course, a skin is pretty dry before it is mounted, but, nevertheless, when placed in the hot, dry air of an exhibition hall, it shrinks a good deal more, and would tear the animal to pieces unless allowed to dry out slowly. So the whole animal is tightly strapped down on its stand by ropes padded with excelsior and allowed to become set to the form shown in center picture, after which it is removed to the place where it is to remain. Such a life-like looking elephant is it that children mistake him for a "really truly" elephant while grown-ups praise the skill of the clever work of the taxidermist.

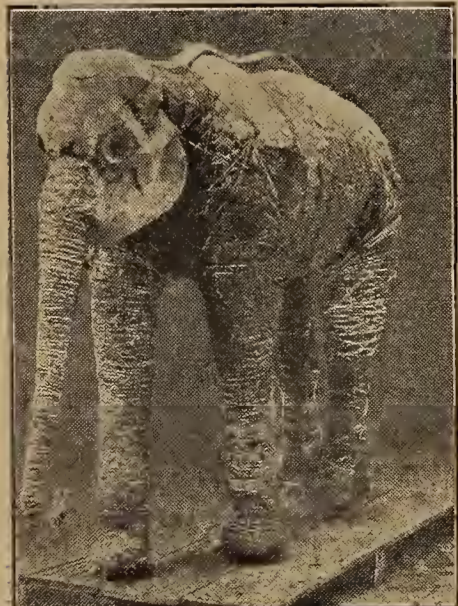

Figure 1.—The skeleton of an elephant ready for mounting



Carryalls waiting outside of one of the consolidated schools to convey the young folks to their respective homes

## An Invalid's Porch Duckery

By Roosevelt Johnson

WHEN the edict went forth that I was to be a prisoner on my sleeping-porch just as my Royal Pekin ducks were due to hatch, I was deeply distressed.

"Never mind," said my enterprising brother, "you shall have them on your porch."

So when the first fluffy golden duckling burst out on the twenty-seventh day—a whole day before any were expected—it was brought direct to me. My porch is large, ten-and-a-half by fourteen feet, having dark-green panels half-way up, the rest enclosed with wire netting. The floor is water-proofed with canvas, painted green. In one corner my brother spread several thicknesses of canvas, and on this placed four boards nailed together, making an enclosure four by five. Over the top was wire netting, an opening being left at one end.

Here we put the babies with their fussy hen mother. She was a nuisance, and after the first week we dis-



The cage where the ducks were kept

pensed with her services. Baby ducks are so hardy that they do not need half the heat required for chickens. At night I put them in a box with a folded newspaper in the bottom, covered them with a square of Canton flannel, and pushed the box under the divan.

During the day I kept newspaper over the canvas on the floor of their cage, as these were easily changed and ducks cannot be kept from splashing water and food about. I fed them four times a day, chiefly on scalded bran mixed with a small amount of beef-meal. Nearly every day they had a leaf or two of lettuce. Always before them stood a low pan of water, deep enough to thoroughly rinse their bills.

At this time my meals were all served on my porch, so I was able to provide the babies with great variety by giving them bits of left-over meat or vegetables. Unlike chickens, ducks thrive better on vegetables than grain, and nothing do they like better than mashed turnips, fortunately turnips are an excellent diet for them. Under this treatment my ducklings developed so



As the elephant looks on exhibition at the National Museum at Washington

rapidly and ate so enormously that at the end of eight weeks a cruel family insisted that they should either be eaten at home or sent to the market. Ducks are such great eaters that it is better, as a rule, to sell them when they are six or eight weeks old as broilers, or by ten weeks, when they are mature, though still young and tender. Here in Colorado we can always get from twenty to thirty cents per pound for broilers, and nineteen cents for grown ducks.

I was obliged to let them all go out of doors when they were about seven weeks old, and by fencing in a corner of the irrigating ditch we made a little pond for them. Royal Pekins can get along perfectly with only an occasional bath, but they are not so happy nor so spotlessly white, so, if it is possible, let them have a daily splash.

My porch duckery proved both a pleasure and a profit to me. It took my thoughts off myself, and made me feel that I was still of some use in the world.

\* \* \*

## The Consolidated Country School

By Maurice M. Meredith

MEN and women who may still consider themselves to be in "middle life" remember how, when they were boys and girls in the country, they walked long distances to attend the country school. Often it was called the "district school," and now and then someone called it the "deestrick skule." Although our population has increased so vastly in recent years, there are not so many district schools in some parts of the country as there once were. In New England one will find many old country schoolhouses in which there has not been a session of school for a decade. This is partly because of the fact that to-day there are not so many boys and girls in New England rural districts as there were then, and partly because so many of the children are now carried to some central school.

The consolidated country school has come into vogue, and the work of education goes on in one schoolhouse instead of in four or five. This bringing together of four or five country schools is less expensive for the taxpayers and it improves the school in many ways. Five or six schools of perhaps twenty pupils each are consolidated into one school of one hundred or more pupils. The one large central building is much better equipped than five or six little schoolhouses could be. It is also possible to grade the large school as the small school could not be graded. Then, too, the children find the large school so much more interesting than the little school. A fine class of teachers can be employed, and the plan has been found to work so well that it is thought that in a few years there will not be a large number of the old-time country schools excepting in small neighborhoods where it is impossible to have the one large central school.

But how do the children get to and from the large central school? This is a very natural question, since it is certain that many of them must live much farther from this school than they did from the little country school. School vehicles are maintained at the public expense and in these carryalls the boys and girls are taken to and from the schoolhouse. Here is an opportunity to develop the social side of life. It brings the young folks together and makes them more eager to attend school, for the good times they have in the carryalls break up the monotony of school life and turn a task into a pleasure. Then it is a relief to the parents of small children. The mother sees her little ones carried away in safety with the other children and can rest assured that they will be returned in safety in the evening.

It will be something of a surprise to many to know that there are fully six hundred of these consolidated country schools in the United States. One will find scores of them in Iowa, Minnesota, Massachusetts, Indiana, Virginia and Georgia. The idea has met with favor in all parts of the country. And yet there are about 300,000 of the isolated country schoolhouses left. In some of them one will find but five or six pupils and the teacher, as well as the pupils, has a rather dull time of it.

Something more than the "three R's" is taught in the new consolidated country school, as one may know from reading the following account of a typical school of this kind: "The model consolidated rural school is situated in the open country with ten acres of land around it. It is substantially built of brick, two-storied, four-roomed, well-built, well-equipped. The ten acres on which it stands are converted into a demonstration farm. There is among the instructors one especially prepared to teach scientific farming. He plants all manner of things that thrive on the farms of the neighborhood in the vicinity of the school."

So it is that the farm boys and girls learn a great deal about practical and scientific farming at the school.



Figure 2.—Fitting the skin over the skeleton—a difficult task

# The Home Interests' Club

By Margaret E. Sangster



WONDER if the members of the Home Interests' Club will enjoy in these August days a peep into the correspondence-box of the editor? August is a month of rare beauty and charm, but for women in the country it is usually full of so many practical kinds of activity that they cannot spare an afternoon for reading papers and sharing in discussions. For one thing, the preserve-closet, which has been filling up by degrees with jams and jellies, still has its vacant shelves, and the thrifty housekeeper likes to add to its contents from day to day. When the winter days come, the home table will be far more appetizing if mother has laid in a generous supply of canned and preserved fruits and vegetables than if she has allowed summer weeks to pass without making ample provision. In August, too, many women take the occasion to pot certain favorite plants, in order that they may have bloom and fragrance indoors when cold weather shall arrive. One season has to wait upon another, and as there are certain household necessities that require forethought, the successful home manager makes her plans in advance and carefully carries them out. In September, the schools will open, and the boys and girls must be made ready for the year's campaign. If Jack and Betty are to leave home for school and college, their outfit must be finished in August, trunks packed, every little detail considered and the demands of the economy wisely met, in these exquisite onward-drifting days.

When you read some of the messages and greetings that have poured into FARM AND FIRESIDE from those who belong to the Home Interests' Club, I fancy you will agree with me that among our home-keeping and home-loving women there are many who grasp and understand the great possibilities of life, and are on the watch for life's broadest opportunities.

## From a Farmer's Wife

"I am a farmer's wife, fifty-three years old, and I have lived until recently in the Middle West. I have been through the thick of the fight, always with a very meager income, permitting no luxuries. By this I mean to speak of furniture, clothes, little journeys and a variety of personal indulgences that we women like to have. Yet a farm home is a good enough place to live a life in, and not so hard and monotonous as many writers represent it. I have been rich in my home, in a good husband, in dear children who have turned out well. Our home is in a community of quiet people, many of whom are more well-to-do than ourselves. Our lives are narrow, but, as a friend wrote me, 'may be both deep and high.' I have learned to accept my limitations. My time is absorbed by little home tasks, by the country school and the Sunday-school. The people around me interest me. We have plenty of good reading in the line of papers and magazines, and my large flower-garden is a never-ending delight. I shall eagerly watch for the subsequent issues of FARM AND FIRESIDE, as I am longing for your words of hope and cheer."

One sentence in this letter must appeal to us all. The woman who is in her early fifties is in the noon-day of life. Time was when she was supposed by her juniors to have reached the border-land of old age. That time has forever passed. The wife and mother or the single woman who has just touched life's Indian Summer has her feet set on sunny uplands from whence she may calmly survey the past and trustfully anticipate the future. The sentence which struck me when I read the letter was that one about having been through the thick of the fight. After the struggle in the day of small things, after privations borne without complaint, after rearing children who have turned out well, and enjoying all along the comradeship of a good husband, a woman may well find great comfort and pleasure and rich rewards in the quiet and tranquil years of health, interest and usefulness that remain to her. My advice to the host of such women is, accept your limitations and retain your enthusiasm and continue to tell the rest of us that the happiest home in this broad land may be a home that draws its sustenance directly from the soil.

Now for another quotation.

## Three Requisites

"Homes cannot exist without woman's presence, woman's cheer and woman's common sense."

Here is the kernel of a substantial truth closely packed in a shell. We have only to look at the makeshift homes with which men are forced to put up, in lumber camps and lonely mining regions and sequestered spots in the signal service, to realize that all by himself one man cannot make a home. Even in groups and regiments of men no home feeling is possible when they are separated from mothers, wives and sisters. A woman can make a home if she have four walls, a chimney, a door and a window. The hearth-fire is never rightly kindled until a woman, kneeling beside it, lights a match. Woman's cheer and woman's common sense must indeed be added to woman's presence, since a woman who is not altruistic and large-hearted will not possess a sufficiency of those qualities to make home what it should be.

## A Girl's Problem

"Can anybody explain why girls in their twenties are often so restless, disheartened and morbid? I am twenty-three and have a good business position and a pleasant home. One would imagine that I might be satisfied, and my older friends would one and all call me a fortunate girl. My girl friends in most instances feel exactly as I do. They see nothing bright in the present life, and as it stretches before them the road looks dull, dreary and uninviting. Tell me whether the Home Interests' Club will be a place where the puzzled girl may slip in, find a cozy corner and sometimes get a cordial hand-clasp?"

Somebody once said that girlhood is not always a happy time, although it is so happy-looking. On the day when this letter was posted nobody would have imagined that there was the least trace of morbidness lurking behind the bright face of the girl who was taking dictation and writing on her little ticking machine in the office where she is employed. The low mood gets hold of us sometimes, and when we are in its clutches it makes little difference whether we are twenty-six or sixty. The thing to do is to trample on this mood, to set it down to physical fatigue, indigestion, the loss of a good night's sleep or the foolish habit of worrying about to-morrow instead of living in to-day. Girls now and then indulge in day-dreams without giving the dreams time to come true. To use another metaphor, they stand on the shore where the waves are tumbling in, and because their little ship of love has not hove in sight, they do not believe that it is on its way across the ocean, sailing in to shore and bringing with it the freight of happiness for which they long. I always feel like saying to young girls,

"Each of you is a princess royal. Do not live as if you were anybody's bond-slave. Whatever life has for you will reach you sooner if you are contented, capable and queenly than if you sit down by the roadside and cry because your doll is stuffed with sawdust and there is nobody to play with you."

## Neighborly Intercourse

The next letter indicates a path to sociability. "Two friends and myself were together one day and it was incidentally mentioned how nice it would be if we could have some kind of a gathering among neighbors, about once a month, in a social way, for since we all have telephones and can chat when we please over the wire, visiting has almost become a thing of the past. So we struck while the iron was hot, sat right down and made out a list of those whom we thought would favor the club idea. We then consulted with them and all were unanimous in thinking it would be great. Our plan was to have twelve members, each in turn acting as hostess. One of the originators took the first meeting. A president and secretary were appointed, the secretary to take minutes and prepare a menu for the dinner at the next meeting. The menu is always ready and read so that you know what you are expected to bring the next time and that there may be a nice variety. We named ourselves the Martha Club, because we are all home-makers like Martha of old, and I forgot to tell you that we are all farmers' wives and live several miles apart, so that less than a day would be no visit at all. The club went off with a flourish from the start, and as yours truly is the local reporter for the county paper, and an account of each meeting is given, we soon had more applications for membership than we could receive. We did swell our number to sixteen, but won't accept any more unless to fill vacancies made by removals or resignations. We therefore have a waiting list. Our reason for keeping the club small is that we wish to welcome husbands and children at the monthly dinner. I have not yet told you what we do. The first feature after all arrive is dinner, which willing hands help the hostess put on the table, as everything brought in must be ready, unless it is to be served hot. Some help serve dinner, others wash dishes as they are removed from the tables, and by the time the last course is served at the last table, nearly all the dishes are done. Such a jolly, happy time we have over those dinners, making a picnic of our daily drudgery! We aim to introduce one new dish every month and, of course, everyone must know how it is made. I wish I had room here to tell you of some of the good things we have. After dinner our business meeting is held, then one or two contests are introduced by the hostess, always laughable or interesting. Every Martha takes part. The lucky winner gets a little prize of some kind, and the one who fails entirely gets the consolation, furnished by the hostess. After this there is a free and frank discussion of practical matters, such as bread-making, chicken-raising, etc. We never bring any work because we feel that we owe ourselves one day of the month for recreation. The men talk and play games, and are just as enthusiastic over the meetings as the women, and sometimes try to do two days' work in one so that they can attend the Martha Club. Everyone goes every time unless unavoidably detained. There is no half-way business about it, and we have never had anything that has been the means of promoting such general interest and good fellowship and cementing old friendships, and forming new, among neighbors as this club."

A specially attractive part of the Marthas' program is the admission of the husbands. The ideal club must include women and men. By the way, men are very welcome in this Home Interests' Club of ours.

## The Danger of Being Self-Centered

"When ours was a new community, there was no lack of sociability. Although we lived at a distance from one another, we took trouble for hospitality. Now a change has come over the place and the neighborhood. Those who were poor have grown prosperous, those who were interested in others are self-centered, and social intercourse is on the decline. Can you suggest a method that might lift us out of our rut?"

Read the description of our breezy friend who tells us how successful the Martha Club has been found. Imitate that club with variations of your own.

## What We Need

"Yes, indeed, I believe in a club. Dear as a woman's home is to her, it should not occupy all her thought and her entire activity. If it does, she will inevitably grow to be selfish, narrow and inelastic. Many women limit their interests to their church-work, but is not this a mistake? Ought we not to seek the steady improvement of our minds, and can we do this better than by intellectual effort in company with others? Women in the country reside remote from intellectual centers and have fewer opportunities for culture than their city friends. Their daily work is exacting and arduous. We have found that our neighborhood club, in which we study the history of our state and the careers of its great men, writing papers and procuring reference books from the state library, is a great help in meeting our mental needs. We follow a prescribed program, and at our alternate meetings the hostess furnishes a musical or literary entertainment of some description. We prohibit refreshments at our ordinary meetings."

## A Welcome Member

"I have always wanted to belong to a good club, but living in the country and being so busy all the time, I could not. The only free time for me is in the evening, and I do not like to take my little four-year-old girl and drive eight or nine miles with her when she ought to be in bed."

Our Home Interests' Club, requiring no dues, no personal attendance and no effort on the part of the members beyond reading this page, sympathizing with its aims and writing helpful letters, meets the precise want of this mother who very properly decides to stay at home with her little girl, rather than take her out when she should be asleep. It meets the need, too, and asks the cooperation of such excellent club-women as the one who tells us of the wide-awake group in her neighborhood.

## How to Get Rid of Ants

"For relief from either red or black ants, get ten cents' worth of oil of sassafras, use freely, and in less than six hours there will not be an ant in the house. Be sure to procure the oil, and of the best quality. Common wrapping-twine, dipped in the oil and wound several times around your sugar-box, will soon rid it of ants."



## Your Kind of Fruit Jar

is the Atlas E-Z Seal, because a touch of your finger locks it so tightly that *all* air must stay out. That keeps your fruit and vegetables as fresh and flavory as when first picked. They can't "work." They can't spoil. E-Z Seal Jars *never* stick. They open in a jiffy by a light pressure of the fingers. No twisting—no trouble—no regrets. See the generous wide mouth of the



—big enough to take fruit *whole*, and you can preserve green corn on the cob, asparagus uncut—and tomatoes with *all* their juices. Atlas E-Z Seal Jars are the jars without a fault. Put this year's preserves into them and you'll wonder why someone didn't make them years ago. At all general stores.

Write now for our booklet of *Famous Preserving Recipes*. We'll gladly send it free.

Hazel Atlas Glass Co.  
Wheeling, W. Va.

**DON'T PAY TWO PRICES—**

Save \$18.00 to \$22.00 on

**HOOSIER RANGES AND HEATERS**

Why not buy the best when you can buy them at such low, unheard-of factory prices! THIRTY DAYS FREE TRIAL BEFORE YOU BUY. Our new improvements absolutely surpass anything ever produced. SEND POSTAL TODAY FOR OUR FREE CATALOG AND PRICES.

HOOSIER STOVE FACTORY 126 State St. Marion, Ind.

**DAISY FLY KILLER**



placed anywhere, attracts and kills all flies. Neat, clean, ornamental, convenient, cheap. Lasts all season. Made of metal, cannot spillover or tip over, will not soil or injure anything. Guaranteed effective. Of all dealers or send prepaid for 20 cents. HAROLD SOMERS 150 DeKalb Ave. Brooklyn, N. Y.

**PARKER'S HAIR BALSAM**

Cleanses and beautifies the hair. Promotes a luxuriant growth. Never Fails to Restore Gray Hair to its Youthful Color. Cures scalp diseases & hair falling. 50c. and 1.00 at Drugists.

I Trust You Ten Days. Send No Money. \$2 Hair Switch Sent on Approval. Choice of Natural wavy or straight hair. Send a lock of your hair, and we will mail a 22 inch short stem fine human hair switch to match. If you find it a big bargain remit \$2 in ten days or sell it and EARN YOUR OWN SWITCH. Extra shades a little more. Inclose 5c postage. Free beauty book showing latest style of hair dressing—also high grade switches, pompadours, wigs, puffs, etc. Women wanted to sell our hair goods.

Anna Ayers, Dept. A277, 22 Quincy St., Chicago



**Send the Coupon Today and Gain**

Send the coupon. Know why this Piano offer exceeds in liberality and in quality of instrument offered all others. Compare with any and all other propositions—then you'll know why music lovers buy thousands of Schmoller & Mueller Pianos early—then you'll understand why our customers are active in the further introduction of Schmoller & Mueller Pianos in their communities. Take the step that, leading to the purchase of a Schmoller & Mueller Piano—will mean the presence in your home of a tested and proven to be satisfactory piano. A piano that will bring joy—happiness to your home circle. That piano is the

**Sweet and Mellow Toned Schmoller & Mueller Piano**

Why should you and your family be longer deprived of the possession of a Schmoller & Mueller Piano, when this offer we're waiting to send you will make the way to ownership for you surprisingly easy. Several years to pay at Fifteen Cents a Day for the Guaranteed Schmoller & Mueller Piano. Let us send you Complete Catalogue—Prices and Offer To-Day. Use the Coupon now—no letter needed.

**Schmoller & Mueller Piano Co.**  
Dept. J. F. F. 8 - Omaha, Neb.  
Schmoller & Mueller Piano Co.,  
Dept. J. F. F. 8, Omaha, Neb.  
Send me Catalog, Prices and Terms on the Sweet Toned Schmoller & Mueller Piano.

Name .....  
Address .....

**This**

**Beautiful Sugar-Shell**

**Without Cost**

WE WANT to send you this beautiful Oxford Silver Sugar-Shell, made by Rogers Company. It is made of heavy plate silver. Entire spoon is six inches long, handle is four inches long, beautifully carved and embossed in the Narcissus pattern and finished in the popular gray French style. The bowl is two inches long and one-and-one-half inches wide, with a beautifully carved and deeply embossed Narcissus in the bottom. It is finished in highly polished silver plate. We guarantee this spoon to be genuine Oxford Silver Plate. If you are not perfectly satisfied, you can return the spoon and we will refund your money. We want to send it to you just to show you how you can earn a set of six Oxford Silver Teaspoons just like it without a cent of outlay, for a slight favor on your part.

**SEND ONLY TEN CENTS**

and one three-month subscription to FARM AND FIRESIDE, and we will mail you, in addition, a genuine Oxford Sugar-Shell, as described above. The Sugar-Shell will be yours to keep, all we ask is that you agree to show it to two of your friends.

Address all orders to

**Farm and Fireside**  
Springfield, Ohio



**The Youngest Artist**  
**A True Story of an Arab's Baby Daughter**

By Lilla Zenib

I DON'T know whether it's an unwritten rule or a matter of mere delight, but nearly every woman traveling in Eastern lands brings back a souvenir for her home. It may be a carpet from Cairo, a screen or a vase from Japan, some brass or silver ware from India. At any rate, when I was in Damascus—a city as old as Abraham's day—people said, "You simply must go to the art factories here, for they make the loveliest things."

I needed no urging. One morning a fat white donkey with a shabby side-saddle was brought to the door by a small boy in a shirt and a red fez.

"Take me down to the furniture factory," I said.  
"Yess," he replied with hissing emphasis, and I thought all was well. Why is it we are so apt to fancy all the world speaks English? "Yess" was all that tiny Arab knew of our tongue. He hadn't the faintest idea where he was to take me. His master had been asked to send a donkey and a boy to the hotel. "His not to reason why!"

The provoking little creature drove the donkey anywhere and everywhere until I grew uneasy. Be sure I greeted our consul with delight when I spied him in the Spice Bazaar!

"Why, you want the Bab Sherki, or East Gate of the city," he said, when I explained things. And thereupon he instructed my small boy.

The youngster grinned and said, "Yess." Then he made a whirring sound, smote his patient beast and set off down the classic "Street Called Straight," which is mentioned in the Bible.

Never had I entered a place so fascinating as that factory, just outside the city wall. An "Aladdin's Palace" of precious things, inlaid with silver and gold and mother-of-pearl. Bewildering vistas of brass and copper and porcelain; of tapestries, embroideries and brocades. So much for the show-rooms, in which a housewife gasped with desire of possession.

But how surprising and how sad was the peep behind the scenes! I have never seen such tiny boys and girls—mere babies, many of them—employed in a factory. Some were tracing patterns on parts of chairs and tables; others hammered silver wire into brass trays and flower-pots. Of course, they all stared and tittered and whispered as the visitor passed. And I'm sorry to say I caught many a muttered "Bakhshish!"—that great watchword in the East, where the foreigner is supposed to possess untold gold.

But my attention was riveted by the sweetest of figures. An infant of not more than four or five sat on a high stool holding a hammer in her tiny fist. Little dimpled fingers curled about the handle; dark curls half hid the serious face. And huge black eyes resolutely followed the silver wire that sank slowly in its pattern of leaves.

"Our youngest artist, lady," said the Arab in charge, waving a slim hand toward the baby. "She works ten hours a day, speaks little, as you see, and takes a real interest in her work."

Tears sprang to my eyes. Surely it was a crime to keep this lovely mite in the hot factory all through this summer's day! What a childhood! No wonder the great large eyes were already grave with the weight of life. It made one's heart ache.

I had to pass on, however. They took me to see how the brass vases and pots are molded; how the intricate inlays are made; how the metals are "Damascened" one upon another. But I always strayed back to the stool of the "youngest artist." She had the head of Correggio's angels, and only glanced at me twice—even then with listless gaze. Tap, tap, tap—and then another length of wire. This was all she seemed to think of.

"She has no mother," I was told. "And her father is a greedy-man, by no means poor. He lives just inside the city walls; and the five piasters a week his little daughter works so hard to receive he thinks well worth while."

I grew weary of bold eyes and the persistent demands for

"Bakhshish" that came even from men workers. There was a pain at my heart when I looked at the dark gentle curls and baby hands of the youngest artist in this humming hive.

I made a sudden resolution to see the cruel father and plead with him for his baby's liberty. The manager gave my donkey-boy directions and I hurried away.

But we couldn't find the house at once, so stupid was my young Arab with the red cap and tattered shirt. My fat white donkey plodded up one crooked street and down another. At last we came out again where we began—at the Bab Sherki, or East Gate of Damascus. And there I saw something that made me pull up and cry out a greeting. For huddling at one side of the great gate, to avoid the endless strings of laden camels, was my baby with the angel head!

Clearly, the big eyes were seeking someone. And me, evidently! No sooner had the roving eyes lighted on mine than the little one ran up with something in her hand. Her lovely face was expressionless as ever; but you can imagine my surprise when she handed me my own silver chain-bag, that contained my Turkish passport, a banker's letter of credit for a large sum and over five hundred francs in French notes and gold!

Without dismounting I hurried back to the factory. There I found I had in my hurry dropped the bag into a big flower-pot by the side of "the youngest artist." None other than she had seen it or—as I was afterward warned—I should never have got it back. True, the letter of credit could have been stopped; but its loss, and especially that of the passport and ready money, would have put me in a serious plight in a land like Turkey.

This time I took a new resolution even quicker than before. I put baby on the saddle before me, and she acted as guide. In two minutes we were climbing the stairs. I found the father a very strict Moslem, but a known miser. Through my interpreter I told him it was a shame to imprison such an infant in the factory for even one hour a day, to say nothing of ten.

Her health would fail, or she would grow up vicious and bring shame on him. I told him how the child had recovered my bag, and offered him five Napoleons if he would take her out of that awful place. My last argument was best. The fellow's eyes fairly shone at the sight of the gold, and he readily agreed.

I made him sign a paper at the consulate and then informed the manager of "Aladdin's Palace" he had lost his "youngest artist." But he was used to the whims of foreigners; and besides I gave him a good order.

Lastly, I took the child—Zuleika was her name—up to the bazaars and bought her a big French doll. When you pressed its chest the blue eyes blinked convulsively and the rosebud mouth gave a queer cry. Whereupon Zuleika spoke for the first time. "Tabark Allah!" (Praise to the name of God!) murmured the little one, as she clasped the doll to her soiled blouse and turned homeward on my own white donkey.

Congratulating Them—A Polish couple came before a justice of the peace to be married. The young man handed him the marriage license, and the pair stood up before him. "Join hands," said the justice of the peace. They did so and the justice looked at the document, which authorized him to unite in matrimony Zacharewicz Perczynski and Leokowards Jeulinski.

"Ahem," he said, "Zacha-h'm-ski, do you take this woman," etc. "Yes, sir," responded the young man. "Leo-h'm-h'm-ski, do you take this man to be," etc. "Yes, sir," replied the woman.

Then I pronounce you man and wife," said the justice, glad to find something he could pronounce; "and I heartily congratulate you both on having reduced those two names to one."—Lippincott's.

**There is a Garden in Her Face**

By Thomas Campion

There is a garden in her face  
Where roses and white lilies blow;  
A heavenly paradise is that place,  
Wherein all pleasant fruits do flow;  
There cherries grow which none may buy  
Till "cherry-ripe" themselves do cry.

Those cherries fairly do inclose  
Of orient pearl a double row,  
Which when her lovely laughter shows,  
They look like rosebuds filled with snow;  
Yet them nor peer nor prince can buy  
Till "cherry-ripe" themselves do cry.

Her eyes, like angels, watch them still;  
Her brows like bended bows do stand,  
Threat'ning with piercing frowns to kill  
All that attempt with eye or hand  
Those sacred cherries to come nigh,  
Till "cherry-ripe" themselves do cry.



# Practical Mid-Summer Clothes

Designs by Grace Margaret Gould



No. 1788—Yoke Play Dress with Bloomers

Pattern cut for 2, 4, 6 and 8 year sizes. Quantity of material required for medium size, or six years, five-and-one-fourth yards of twenty-two-inch material, or three-and-one-fourth yards of thirty-six-inch material, with one-half yard of all-over embroidery for trimming. Price of this pattern is ten cents



No. 1719—Tucked Tailored Shirt-Waist

Pattern cut for 32, 34, 36, 38, 40 and 42 inch bust measures. Quantity of material required for medium size, or 36-inch bust, four yards of twenty-four-inch material, or two-and-one-half yards of thirty-six-inch material. Price of this pattern is ten cents



No. 1789—Child's Yoke Dress—High or Low Neck

Pattern cut for 6 months, 1, 2 and 4 year sizes. Quantity of material required for medium size, or 2 years, one-and-three-fourths yards of thirty-six-inch material, with one fourth of a yard of all-over embroidery for yoke and armbands, and three yards of edging for ruffle. Price ten cents

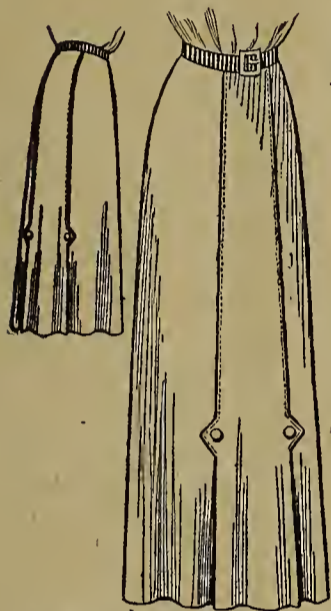

No. 1677—Narrow Skirt with Foot Plaits

Pattern cut for 22, 24, 26 and 28 inch waist measures. Length of skirt all around 40 inches. Quantity of material required for medium size, or 26-inch waist, four-and-one-fourth yards of thirty-six-inch material, or three-and-three-fourths yards of forty-four-inch material. Price of this pattern ten cents



No. 1627—Set of Baby Patterns

Patterns cut in one size. Quantity of material required: For the cloak, two-and-five-eighths yards of thirty-six-inch material; for the dress, two-and-three-fourths yards of thirty-six-inch material; for the wrapper, two-and-one-eighth yards of thirty-six-inch material; for the kimono, seven eighths of a yard of thirty-six-inch material. The price of this Set of Baby Patterns, including all four garments, is ten cents



No. 1671—Scant Four-Gored Skirt

Pattern cut for 22, 24, 26 and 28 inch waist measures. Length of skirt all around, 41 inches. Quantity of material required for medium size, or 26-inch waist, five yards of twenty-seven-inch material, or four-and-one-eighth yards of thirty-six-inch material. Price of this pattern ten cents



No. 1786—Morning Dress with Rolling Collar

Pattern cut for 32, 34, 36, 38, 40, 42 and 44 inch bust measures. Quantity of material required for medium size, or 36-inch bust, seven-and-three-eighths yards of twenty-seven-inch material, or five-and-seven-eighths yards of thirty-six-inch material, with three eighths of a yard of contrasting material thirty-six inches wide for collar, cuffs and belt. Gingham, chambray and linen are all suitable materials for these models. The price of this pattern is ten cents

## How To Get the Patterns

If you want your clothes to be right in style and yet practical, use the famous WOMAN'S HOME COMPANION patterns which we supply at the low price of ten cents each. The patterns for children's clothes are especially good. They all cost ten cents apiece, with the exception of the set of baby patterns, which is a decided bargain, as you get four patterns for ten cents.

So great has been the demand among FARM AND FIRESIDE readers for our WOMAN'S HOME COMPANION patterns that we have established three offices or depots from which these patterns can be obtained, as follows:

Eastern depot: FARM AND FIRESIDE, 381 Fourth Avenue, New York.

Central depot: FARM AND FIRESIDE, Springfield, Ohio.

Western depot: FARM AND FIRESIDE, 1538 California Street, Denver, Colorado. We suggest that you send your order to the depot that is nearest to you to facilitate the quick delivery of the pattern.

### A Premium Offer

To any FARM AND FIRESIDE reader who sends us one new subscription to FARM AND FIRESIDE with fifty cents for the same, we will give as a premium for the subscription one WOMAN'S HOME COMPANION pattern. To obtain a pattern without cost, send the subscription to FARM AND FIRESIDE, Springfield, Ohio.



No. 1741—Peasant Waist with Revers

Cut for 34, 36, 38, 40 and 42 inch bust. Material for 36 bust, one-and-five-eighths yards of thirty-six-inch material, with three-eighths of a yard of contrasting material for chemise. Price of pattern ten cents

No. 1742—Flounce Skirt, Buttoned in Front

Cut for 24, 26, 28, 30 and 32 inch waist. Material for 26-inch waist, three-and-one-half yards of thirty-six-inch material. Price of pattern ten cents

ASK FOR

PRINTS

**Quality that is never lowered**

Three generations of women have worn these beautiful black dress-goods because of their unvarying high quality that "pays to make up."

**Simpson - Eddystone Solid Black Prints**

are high-grade calicoes of enduring quality; and the intense fast color is as lasting as the cotton fabric itself. They are backed by 68 years' experience.

Show this advertisement to your dealer when you order, and don't accept substitutes. If not in your dealer's stock write us his name and address. We'll help him supply you.

**The Eddystone Mfg. Co., Philad'a**  
 Founded 1842 by Wm. Simpson Sr.

## Fifty Beautiful Post-Cards Assorted Subjects For Farm and Fireside Readers

We have just concluded another Post-Card deal which enables us to offer our friends an assortment of fifty cards of the very best quality and design, absolutely without cost.

These cards are without doubt the acme of post-card production. They are lithographed in many colors and the designs are new, original and attractive.

### You Will Want These Cards

And we want you to have them. The subjects are many and varied, and can be applied to all occasions, such as Birthday Greetings, Best Wishes, Good Luck, etc.

We give you our positive assurance that a finer assortment of Post-Cards cannot be obtained anywhere. These cards are the best in every particular.

### Write To-day for Particulars

We will reply immediately telling you how you may obtain this fine assortment of high-colored, high-finished, high-priced Post-Cards without a cent of cost to you.

Write at once. Address

**FARM AND FIRESIDE**  
 Post-Card Department, Springfield, Ohio



## JAP ROSE

"The Original Transparent Soap"

Skin and clothing are entirely different things. Naturally they require entirely different soaps. Jap Rose is essentially a skin cleanser. Made from the purest vegetable oils, blended by our own process. Perfect for the bath. Lathers freely in hard or soft, cold or hot water.

Sold by dealers everywhere

**Refuse Imitations**  
 Look for the Jap Girl on every package.

**A Large Cake 10c**







# SUNDAY READING

## Getting to Heaven Quick

By Dr. John E. Bradley



STORY is told of a prayer-meeting in a down-town church in New York, at which a brother got up one night and said: "I never was so happy before in all my life. The sky is clear and a gentle breeze is blowing. I feel that I am sailing away to heaven at the rate of six knots an hour." As soon as he sat down, another brother sprang up, saying: "I feel just the same way. The sea is smooth and a stiff breeze is blowing me on toward heaven at the rate of ten knots an hour." The next brother said a gale was wafting him on to heaven at fifteen knots an hour, and a fourth one said, "The brethren who have spoken are going pretty fast, but I am going still faster. The sky is fair and the way is clear and a cyclone of glory is bearing me on to heaven at the rate of twenty knots an hour." He sat down amidst great enthusiasm, after which there was a long pause.

At length a little old woman, who had been sitting quietly in one corner of the room, said: "I am glad my brethren are getting along so fast. As for me, I've been so busy with my housework and helping one of my neighbors who is sick, that I haven't had time to sail away to glory. A good many people are not going my way, and I am not going as fast as some of you are. I hope I'm getting ahead, but I want to tell these brothers who are going so fast that, if they don't look out, they'll bust their boilers and never get to heaven at all." Strange to say, there was not an *amen*, nor an approving word, when the old lady sat down.

### Are You Doing Your Best?

Perhaps these fast-sailing brethren will all reach heaven in due time. Let us hope so. But are they helping others to get there? Are they doing anything to transform this world into a heaven? Their sister is. She is modest and does not realize all the good she is doing, but if we had a world full of such Christians, it would already be a heaven. How easy it would be if only we all felt and acted as she does. How happy it would make us. The woman who is tired and discouraged would find her strength renewed and her spirit revived by saying something to cheer up her sister. In many ways she can help the suffering, the needy and the lonely.

Scanty fare for one will often  
Make a royal feast for two.

And a man can at least stand four-square for what is just and right in his dealing with his fellow-men. He can speak a friendly word to his unfortunate brother and thus forget his own misfortune. He can join with others in fighting to suppress public wrongs—to drive out the saloon or to kill graft.

In his Berlin address last summer, Mr. Roosevelt said: "The play of new forces is evident in the moral and spiritual world. The things of the spirit are more important than the things of the body, and they are more and more gaining control." The world is making progress, lives are richer and more helpful because there are higher aims and broader influences. The spirit, the purpose, with which we live is more important than what we accomplish. Integrity, kindness and useful industry are fundamental virtues which everyone may possess; and they are more important than the more showy traits.

### Be Thoughtful of Others

It is good to hear from the lips of a statesman of world-wide distinction the assurance that all peoples are catching the spirit of brotherhood, but it is still better to see this spirit acted out in every-day life—in households and neighborhoods. The surest remedy for our own ills is doing something for the ills of others. The poorest and most unsuccessful remedy for our trials and troubles is to brood over them. We need interests which will turn our thoughts away from ourselves and arouse a desire to help others.

Twenty-five years ago, Spurgeon, that matchless preacher, said that "the Golden Rule escaped from the church last week, where it was frescoed on the walls, and wandered down to the Stock Exchange, where it made a great disturbance and was quickly hustled out of doors."

There is still plenty of wrong-doing—business is not always on the square—but tricks of trade, overreaching and decep-

tion have to hide their heads pretty carefully. If Spurgeon were preaching to-day, he would hardly say what he said twenty-five years ago. With our railroads and other great corporations brought under control for the general good, with Roosevelt and many other statesmen preaching the square deal, we are surely moving toward an era of civic righteousness. That is, we are learning to make our religion practical, we are trying to remember the teachings of the Master.

### Radiate Cheerfulness

The Golden Rule applies to little things as well as great. When we minister to the sick or help the needy, we honor Him. When we are kind and cheery in our daily life, we are in the world's broadest field of service. If "he that ruleth his own spirit is greater than he that taketh a city," then it must be true that when we check an impatient word, when we bear up bravely under disappointment, when we are steadfast in our faith in God and faith in our fellow-men, we show His spirit and His blessing upon us is assured.

The spirit of the Master, the spirit of service, has never before been in the world as it is to-day. Think how many are trying to be kind and helpful, how many are devoting their lives to doing good. Why, it is like a liberal education just to know of the things that are being done in the hospitals and asylums and institutions and settlements and medical missions and industrial missions and in a hundred other ways almost the world over.

Last winter a professor in the University of Berlin published an article in a Berlin paper in which he claimed to prove that "no such personage as Jesus of Nazareth ever lived." It attracted attention and soon a merchant attached a denial of the assertion to his sign. Other shopkeepers took it up, and soon the slogan "Jesus lives" blossomed out all over Berlin. A meeting was called for the following Sunday, to be held in the great circus, to protest against this attack upon our Lord. When the hour arrived, the place was filled—packed with a crowd of ten thousand people—while twelve thousand more struggled for admittance. Unable to enter, this great multitude formed in procession and marched through the streets singing Luther's hymn, "A mighty fortress is our God," and "I know whom I have believed."

### The Real Heavenly Spirit

It is well to look forward to our heavenly home—to be prepared to go there when our time shall come. But our fitness for heaven is shown by our lives here.

Do you ever watch your little boy as he flies his kite? He tosses it in the air and slowly lets out the string as it mounts aloft. Little by little it rises higher and higher, till at length it seems only a speck in the sky. How it pulls upon the string as if seeking to break away from earth and fly aloft into heaven. But should the lad lose his hold, should the cord that grips it to earth break, instead of soaring away to heaven, it will fall to the ground a broken and shapeless little wreck.

Thus it is with our aspirations. They can bear us heavenward only as we gain the heavenly spirit—only as we are interested in helping others here. Sailing away to heaven while men and women are sinking beneath the waves all around us is pretty selfish business. They show the heavenly spirit who seek to lift others, to comfort them in their sorrow, to cheer them in their discouragement, to turn them from their sin. When that spirit is gained, we will strive, not to get to heaven quick, but to make the world about us better—an image and foretaste of heaven.

### Religious Facts of Interest

Thomas M. Honan, the new speaker of the Indiana House of Representatives, is a Roman Catholic of Irish and German stock, and is said to be one of the best informed men in the House.

In 1801, there were about 2,340 church edifices in America, valued at about a million and a half dollars. Now there are 187,800 church buildings valued at \$734,000,000, and the annual expenses are \$287,000,000.

In Boston, the Protestant Episcopal Church has made the most progress of any denomination in the past ten years—nineteen parishes increasing thirty-two per cent., and in the suburbs the growth has been greater.

In Lisbon, Portugal, there are thirteen native Protestant congregations of Presbyterians, Episcopalians, Methodists, Congregationalists and Darbyites. While there is complete religious equality, there are occasional instances of priestly and even magisterial opposition and annoyance.

Mr. Frederick A. Wallis, New York's superintendent of insurance, who resigned a position paying him a salary of \$17,500 for this one of \$7,000, is an elder of the Fifth Avenue Presbyterian Church, and superintendent of that church's great East Side mission. Mr. Wallis is a great Sunday-school man.

Mr. S. N. Simpson, a wealthy real estate man of Kansas City, who is in his eighty-third year, has been connected with the Sunday-school as a pupil or teacher for seventy-five years, and is still an enthusiastic worker. Mr. Simpson's first teaching was done at the Five Points Mission, New York, called the House of Industry. He had eighty boys in his department and gave each one a penny for every attendance at the Sunday-school.

The recent conversion of Mr. Chang Po Ling, one of the leading educators and philanthropists of Tientsin City, has aroused much comment in various government circles in China. Mr. Chang is now under orders to investigate education in the United States, Germany, France and England.

It is stated that some of the oldest independent organizations of the Congregational Church in Scotland have recently suspended for lack of support, the conservative members seeking a home among the Presbyterians and the radical among the Unitarians or elsewhere, and that Congregationalism is to-day only two-thirds as strong north of the Tweed as it was a few years ago.

It Works Like a Kodak.



## The 2A Brownie

For Pictures 2½ x 4¼ inches.

DETAIL—Meniscus Achromatic lens, Eastman Rotary Shutter, with set of three stops, for snap-shots or time exposures. Equipped with two finders. Loads in daylight with Kodak Film Cartridges. Covered with fine imitation grain leather and has full nicked fittings.

QUALITY—Made in the Kodak factory by Kodak workmen under Kodak superintendence.

PRICE, \$3.00.

Other Brownies, \$1.00 to \$12.00.

EASTMAN KODAK CO.

382 State St., ROCHESTER, N. Y.

Catalogue free at the dealers or by mail.

It is to your advantage to mention Farm and Fireside in writing to advertisers. Farm and Fireside folks get the very best attention.

**The Grocer's Answer**

"No, Madam, we don't sell soda crackers by the pound any more.  
"No matter what precautions are taken, bulk soda crackers absorb dust and moisture. In a few days the crackers become musty and soggy, and taste like most anything except a *good* cracker.  
"If you want a light, dainty soda cracker—a cracker that tastes as if it just came from the oven, then take home a box of Uneeda Biscuit.  
"These soda crackers are crisp and full flavored throughout.  
"When you get them home, open the package and you'll see how fresh, firm and flaky the moisture-proof package keeps them."

5c

In the moisture-proof package

NATIONAL BISCUIT COMPANY

Never sold in bulk

# FARM AND FIRESIDE

THE NATIONAL FARM PAPER

LIBRARY  
RUB  
AUG 1911

U. S. Department of Agriculture



ESTABLISHED  
1877

AUGUST 25  
1911



"The leaves above, their sunny palms outspread"

**HARLEY-DAVIDSON**

**MR. FARMER**

**T**HOUSANDS of progressive farmers are buying Harley-Davidson Motorcycles this year. Buying them because they travel 10 miles for a cent, less than the wear and tear on their team and rig if they drive.

Buying them because they make any trip in one-fifth the time consumed driving.

Buying Harley-Davidsons because they have proven themselves to be the most economical machines made at any price.

The Harley-Davidson holds the World's record for economy besides innumerable speed records.

It is the only machine which has ever been awarded a 1000+5 score and the diamond medal in an endurance contest.

Nearly one-third of all the motorcycles sold in America are Harley-Davidsons. Made and guaranteed by the largest exclusive motorcycle factory in the world. Send for literature.

**HARLEY-DAVIDSON MOTOR CO.**  
MILWAUKEE, WIS. 643 L-ST.

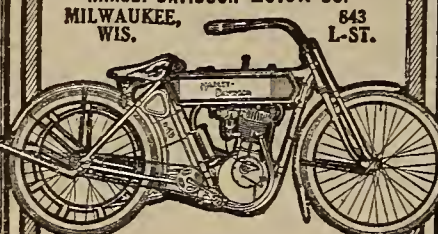

**\$50 TO \$300 SAVED**

We are manufacturers, not merchants. Save dealers, jobbers and catalog house profit. I'll save you from \$50 to \$300 on my High Grade Standard Gasoline Engines from 1 1/2 to 25 H.P.—Price direct to you lower than dealers or jobbers have to pay for similar engines in carload lots for spot cash.

**GALLOWAY**

Price and quality speak for themselves and you are to be the sole judge. Sell your poorest horse and buy a 5-H.-P. only \$119.50

*Direct From My Factory on 30 Days Free Trial. Satisfaction or money back. Write for special proposition. All you pay me is for raw material, labor and one small profit. Send for my big BOOK FREE.*



Wm. Galloway, Pres.  
Wm. Galloway Co.  
746 Galloway Station  
Waterloo, Iowa

**O.K. CHAMPION DIGGERS**

Get all the Potatoes out of the ground in perfect condition. Our Two-Horse Elevator Digger saves time in your harvesting, and saves money on your own crop. We invite comparison with any others.

**Free Large Illustrated Catalogue** giving particulars, prices, etc., of our full line of Planters, Sprayers, Diggers, etc., on request. Write today.

**CHAMPION POTATO MACHINERY CO.**  
199 Chicago Ave., Hammond, Ind.



**Gem City Business College**  
Quincy, Illinois

Annual attendance 1400. 23 teachers. Students from majority of states. Occupies its own \$100,000 specially equipped building.

**Good Positions** await our graduates. Thorough courses in Shorthand, Typewriting, Bookkeeping, Actual Business Practice, Penmanship and Mathematics. Write for our beautiful illustrated catalog and year book free.

**D. L. Musselman, Pres.,** Lock Box 14, Quincy, Ill.



**THE LARGEST AND BEST LINE OF WELL DRILLING MACHINERY** in America. We have been making it for over 20 years. Do not buy until you see our new Illustrated Catalogue No. 15. Send for it now. It is FREE.

**Austin Manufacturing Co., Chicago**

**WELL DRILLING Machines**

Over 70 sizes and styles, for drilling either deep or shallow wells in any kind of soil or rock. Mounted on wheels or on sills. With engines or horse powers. Strong, simple and durable. Any mechanic can operate them easily. Send for catalog.

**WILLIAMS BROS., Ithaca, N. Y.**

**ADMIRAL 2-MAN PRESS**

**3 FEEDS TO THE ROUND SELF FEEDER**

**CONDENSING PACKER**

**ADMIRAL HAY PRESS**

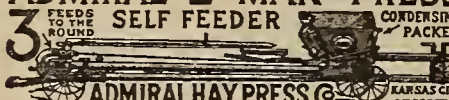

**50 WEDDING INVITATIONS or ANNOUNCEMENTS.** neatly printed, (2 sets envelopes), \$2.50 prepaid.

**STEKETEE PRINTING COMPANY, Muskegon, Michigan**

**PAINT**

**Highest Quality**

Ready-mixed ever sold direct to the consumer. All middle-men's profits saved.

Write for FREE Color Card, Price List and Booklet which tells the whole story.

**YUMA PAINT CO.**  
820 E. Monument Ave.  
Dayton, Ohio



# With the Editor

FIFTY to sixty miles a day is not so very fast going. Most of us have done it on good roads with a smart-going team of roadsters, but it makes them leg-weary, and the humane horseman feels like apologizing to the steeds the next morning when they start off stiff and sore, and with pains and twinges work into their stride again.

But with an automobile it is different. The driver can take a hill with a zip and never think of animal distress, or feel the duty of stopping at the top for breath. And if the journey be for purposes of observation and mental stimulus, he has time for long stops. He can do the chores, and allow himself a late start. He can travel in the heat of the day—the breeze through the top makes the heat more endurable going twenty miles an hour than standing still. The engines work all the better for being warm. If he desires he may throttle her down as slow as a good, stiff trot and admire the views that sweep astern as he goes on. He can take a detour of miles by letting her out and hitting up the speed. He can do as he pleases.

I belong to the Automobile Users' Association of America, one of those numerous societies which the invention of the motor-car has brought into being. It has more members, and more enthusiastic ones, than the Grange, the American Society of Equity and the Farmers' Union combined. It has no secret ritual, no stated meetings, no annual conventions. In fact, its policy is to avoid meetings consisting of more than three or four of its members. Perhaps I had better tell you now who are the members of the A. U. A. of A. Our great association consists of those citizens and their families who do not own automobiles, but use those of their friends.

As a member of the A. U. A. of A., I took a sixty-mile jaunt all on a July day with my friend, the Professor of Agricultural Economics, in his machine. With us went the University Pastor and Lecturer on Rural Life and the Graduate Student who is preparing to write a thesis on rural conditions in a certain township. The Pastor and the Student are also members of the A. U. A. of A. With only three members gathered together, in a five-passenger car, we had a most harmonious convocation. We could even have accommodated another member.

We jogged along slowly at a speed beyond the wildest dreams of the kings and emperors of a few years ago. We talked of the influence of running streams on the imaginations of children and agreed—this was the Pastor's idea—that for a boy to follow the mysteries of a brook, with its lily pools, its rapids, its fishes, its crabs, its blood-suckers and other wonders, is as inspiring, as opening to the mind, as beneficial in every way, as is a tour of Europe to grown-ups. We decided that we all should take more interest in the play of the children. We all live for the years after we reach fourteen in the glamour of the memories of childhood. Why not make it as glamorous as possible? Why not make the early years as rich as possible in the treasures that last so long and cost so little?

At the bridge there was a store and a few houses—a hamlet. We stopped to talk with the storekeeper—for the crossroads storekeeper always knows all about the neighborhood. He told us that we had passed a cheese-factory back a few hundred yards, and we went back to investigate. It was a factory where brick cheese is made. The farmers own it, but we could not make up our minds just how purely coöperative it is. If any of you are thinking of organizing a coöperative society, don't fail to study the patronage dividend plan. It is embodied in the Rochdale method. If you want to know about it, we shall be glad to put you in the way of getting the best advice there is on the subject. Coöperative movements among farmers are successes or failures by reason of just two things—form of organization and quality of management.

But here we found a most interesting thing in the fact that this cheese-factory is managed by a man who runs several others. I believe he manages eleven of these factories, and if he receives the same from all as he does from this one, he has salaries amounting to \$2,750—a fair salary for one who was recently a bookkeeper.

Do you see where the principle leads to? It leads to the coöperative hiring of middlemen everywhere, and for all produce. It means that the huge fortunes of the grain, produce, meat and fruit trades will cease to be made. It means that the wealth by which they are yearly built up will be retained in the hands of the producers.

But we can't stop here, while getting the good of our friend's motor-car. We go on, and dine with a farmer friend who, though robbed of an arm by the fortunes of the Great War, has been a prosperous farmer and a pillar of society ever since and still is.

We visited a man who bought, out of the savings of a tenant farmer, forty acres of land at \$50 an acre—paying \$1,300 down and going in debt for the balance, and who, when he had paid for it, bought another forty at twice the price—and has paid for that, too.

He has a cement water-tank of ample size for all his stock, which he built himself at an expense aside from his labor of \$10. It is built with a partition through the middle, so each side can be cleaned without stopping the water-supply. On the next farm, we saw a round tank built by pouring cement around the old stove tank, removing the staves and cementing the bottom—a trick worth knowing—two tricks, in fact. Then we were shown a good silo, built like a room about fourteen feet square, and cut off at the corners so as to make them round. The farmer built this by farm labor—dug down a few feet, cemented the pit, built a good concrete foundation over it, made a very strong frame of two-by-fours, shiplapped on the outside like a barn, covered it on the inside with metal lath and plastered it with cement. It cost a hundred and fifty dollars and holds silage enough to last fifteen cows from October to May.

"The experts can prove," said the owner, "that a round silo is cheaper, but this didn't cost so very much, did it? And wood butchers like us can work on the square better than on the round. Besides, I like to have buildings square so I can build to 'em handy."

In view of the fact that the silo had given perfect satisfaction for some years, I couldn't show any flaw in his reasoning.

I wish we all had automobiles. I believe it would make us better farmers. I'm sure this day will make me sure of several things. When you read about a thing you get the ghost of it. When you see it, you half believe. It is only when you do it yourself that you really believe, however.

*Robert Quinn*

## Index to Advertisements

	PAGE
<b>Agents Wanted</b>	
Myers Company, C. A. ....	12
<b>Automobiles</b>	
Chalmers Motor Company .....	12
Willys-Overland Company .....	10
<b>Awls</b>	
Myers Company, C. A. ....	12
<b>Carriages and Accessories</b>	
Boob Wheel Company.....	9
Electric Wheel Company.....	6
Mutual Carriage and Harness Company..	12
<b>Clothing, Etc.</b>	
Eddystone Manufacturing Company.....	18
Woonsocket Rubber Company.....	10
<b>Correspondence and General Schools</b>	
Engraving School.....	18
Gem City Business College.....	2
Indiana Veterinary College.....	6
Page Davis Company.....	18
<b>Farm Engines</b>	
Galloway, William.....	2
Fuller & Johnson Mfg. Company.....	11
<b>Farm Tools and Implements</b>	
Champion Potato Machinery Company... ..	2
Common Sense Conveyor Company.....	6
Collins Plow Company.....	11
Dick Manufacturing Company, Joseph..	12
New Process Manufacturing Company... ..	6
<b>Fences and Fencing Materials</b>	
Bond Steel Post Company.....	6
<b>Fertilizers</b>	
German Kali Works.....	9
<b>Food-Stuffs</b>	
Coco-Cola Company.....	20
National Biscuit Company.....	20
<b>General Merchandise</b>	
Macy & Company, R. H. ....	7
National Cloak and Suit Company.....	17
<b>Hair Goods</b>	
Ayers, Anna.....	18
<b>Hay-Presses</b>	
Admiral Hay-Press Company.....	2
Ann Arbor Machine Company .....	9
Auto-Fedan Hay-Press Company.....	6
Dain Manufacturing Company.....	11
Ertel Company, George.....	6
Kansas City Hay-Press Company.....	11
Spencer, J. A. ....	12
<b>Household Miscellaneous</b>	
Hoosier Stove Company.....	18
Kirk & Company, James S. ....	17
<b>Hydraulic Presses</b>	
Hydraulic Press Manufacturing Company ..	6
<b>Land</b>	
Lochrie, George R. ....	6
McBurney & Company, B. F. ....	11
Northern Pacific Railway.....	9
Sacramento Valley Development Ass'n... ..	6
Strout, E. A. ....	11
<b>Live Stock, Food Stuffs and Remedies</b>	
Newton Remedy Company.....	7
Silver Company, L. B. ....	6
<b>Paints</b>	
National Lead Company.....	6
Yuma Paint Company.....	2
<b>Patents</b>	
Coleman, Watson E. ....	12
Farnham & Sues.....	12
<b>Publications and Printers</b>	
American Magazine, The.....	15
Curtis Publishing Company.....	8
Steketee Printing Company.....	2
<b>Pumps</b>	
Temple Pump Company.....	12
<b>Roofing</b>	
Barber Asphalt Paving Company.....	6
Century Manufacturing Company.....	9
Edwards Manufacturing Company.....	6
<b>Separators</b>	
Sharples Separator Company .....	7
<b>Sporting Goods</b>	
Harley-Davidson Motor Company.....	2
Mead Cycle Company.....	9
<b>Telephone Apparatus</b>	
Western Electric Company.....	11
<b>Well-Drilling Machines</b>	
Austin Manufacturing Company.....	2
Williams Brothers.....	2

## ABOUT ADVERTISING

FARM AND FIRESIDE does not print advertisements generally known as "readers" in its editorial or news columns.

Mention FARM AND FIRESIDE when you write to our advertisers, and we guarantee you fair and square treatment. Of course we do not undertake to adjust petty differences between subscribers and honest advertisers, but if any advertiser in this paper should defraud a subscriber, we stand ready to make good the loss incurred, provided we are notified within thirty days after the transaction.

FARM AND FIRESIDE is published on the 10th and 25th of each month. Copy for advertisements should be received twenty-five days in advance of publication date. \$2.00 per agate line for both editions; \$1.00 per agate line for the eastern or western edition singly. Eight words to the line, fourteen lines to the inch. Width of columns 2 1/4 inches, length of columns two hundred lines. 5% discount for cash with order. Three lines is smallest space accepted.

# FARM AND FIRESIDE



PUBLISHED BY  
THE CROWELL PUBLISHING COMPANY  
SPRINGFIELD, OHIO  
Branch Offices: 381 Fourth Avenue, New York City; Tribune Building, Chicago, Illinois  
Copyright, 1911, by The Crowell Publishing Company  
Entered at the Post-Office at Springfield, Ohio, as Second-Class Mail Matter

## A BLUE MARK

in the square below indicates that you are an old subscriber and that your subscription expires this month. Renew by accepting one of our offers before they are withdrawn.



## SUBSCRIPTION PRICE

One Year (24 numbers) 50 cents  
Canadian, 1 Year . . . 75 cents

Subscriptions and all editorial letters should be sent to the offices at Springfield, Ohio, and letters for the Editor should be marked "Editor."

Silver, when sent through the mails, should be carefully wrapped in cloth or strong paper so as not to wear a hole through the envelope.

Vol. XXXIV. No. 22

Springfield, Ohio, August 25, 1911

PUBLISHED  
SEMI-MONTHLY

At Ithaca, New York, in the latter part of July there met an important conference of the Y. M. C. A. for the purpose of establishing some agency for the training of rural leaders. The Y. M. C. A. of the city has conditions as different from those in the country, as asphalt is different from bluegrass. Such conferences ought to do great good.

### Going to the Fair

WHEN we try a thing we're not used to, it tires us. Just being amused for a day is hard work for the man, woman or child who is in the habit of laboring from early morn to the more or less weary eve.

Being amused taxes a new set of muscles, physical and mental, and they ache. That is why we come home from the fair, tired, confronted by the belated milking and saluted by the protesting moo of cows with uncomfortable udders, and irritated by the pigs through the cracks in the pen, squealing porcine profanity at the long overdueness of the evening slop.

But it pays to tax the unaccustomed muscles. A change of work is as good as an hour's rest, and a day at the county fair will refresh us for a month. Perhaps we can arrange this year for the Joneses to take care of the stock on the second day while we go, they to go the third, while we do their chores, or by some other bit of neighborly coöperation. Anyhow, even at the expense of a little disarrangement of the feeding and milking hours, let us go. If there is a boys' camp, let the boys go every day. Similarly, if there's a girls' camp, let the girls go. In each case only if the camp is to be well managed and under capable and trustworthy superintendence. The county fair is a good thing to attend. There are lessons in breeding, feeding, cropping and soil management for the men, and all sorts of poultry and domestic-science lessons for the women.

And there's gossip, "visiting" and politics—all important. It may rain on the new buggy or motor-car, and you may promise yourself when you get the hogs out of the garden, and the cows out of the corn, that you'll never go again, but you should not keep such a promise.

You'll feel better for the relaxation. You need it. And you may get your start in better stock or better seeds at the fair. Many a man has. Anyhow, you'll rub up against the good farmers of the county. This is worth the time—and the tiring of the unaccustomed muscles.

### Peace and Grease

DON'T let the fellow on the wheel  
Complain: "I'm dry; I long for rain,"  
Nor let the axle loudly squeal:  
"I need some grease to ease my pain."

Keep axle greased, keep tire tight,  
'Twill stop all needless creak and rub.  
Then none can say the fellow spoke  
About the hubbub at the hub.

Cut alfalfa as soon as the new shoots start up from the roots at the base of the stalks. And don't wait until the shoots are high enough so you'll cut them. A volume on alfalfa-cutting would be well worth buying if only these two truths were remembered.

The sheep-feeders have lost a lot of money in the last eighteen months. But have you heard of any losses of those who have been selling prime lambs reared by themselves? The sort of sheep-breeding which we have been advising farmers to engage in has paid, and paid well.

### Don't Keep Everything to Yourself

DID you pull off some farming success this year with which you are pretty well satisfied? Then why keep it to yourself? Write it in to us with full particulars and results, as accurately set down as possible. Tell us while it is fresh in your mind. A South Dakota farmer has written us an account of his experience with soy-beans for hogs—fresh from the practical struggle with the problem. We shall keep it until next winter and give it to you corn-belt farmers who corn your hogs to death. And tell us of your mistakes—if you have them figured out so there's a lesson in them. Sometimes the story of how a man fell down is as useful as the tale of how he got up. Maybe more so. Anyhow, don't keep everything so mum. Be sociable.



Have you tried canvas or duck hay-caps this year? It's hard to make good alfalfa-hay in humid regions without them—or clover, or cow-peas, or soy-beans, or sorghum, or sowed corn-hay, either. Make big cocks of the half-dried hay. Make the caps square. Fasten them on by an iron nut at each corner, or a little pat of cement squeezed on and allowed to set, or a sharp stick as large as your finger and a foot and a half long and stuck in the ground. And then let the hay cure in the cock. It will pay.

### Having Eyes, We See Not

DID you ever take a good look at a kernel of corn? And did you then ever compare that kernel with other kernels and calculate which had most food value? Or have you been in the habit of just glancing at the ear or the shovelful and saying, "That's all right, I guess."

Now, corn is an easy seed to examine. Wheat, oats, rye and barley are smaller, and the seed from the individual plant is harder to separate from the rest. Therefore, with the small gains, we fail more grievously to use our eyes. If you will look over your fields of grain, you will find a large proportion of stools that are weak and unprofitable because the seed sown was not plump, strong and full of vitality. The fanning-mill will do a great deal to separate the good seed from the poor, and should be used to the limit. It will pay to fan a hundred bushels of oats to get ten bushels of the heaviest for seed. But why not establish small patches of pure-bred small grains for seed-patches? Use your eyes on the growing crops and the unsown seed, and let nothing but the best go into your land.

In the matter of grass-seed and the seeds of the legumes, our eyes are still less useful to us, unless we use them for sharp and intense looking. Grass-seeds are the carriers of more foul seeds than any others. Can you tell a red-clover seed from that of dodder?

Can you tell alsike from white-clover seed, or sweet clover from alfalfa? And do you tell, before you sow? Or do you just buy seed in bulk and sow in the sublime but idiotic faith that "it's all right?" Your state-experiment station will probably send you a bulletin, if you ask for it, telling how the seeds you sow are to be told from the noxious stuff which is likely to be mixed with it. As ye sow, so also shall ye reap. Cockle to cocksure; dodder to the dodderer; chick-weed to the hen-headed.

### When to Sell Corn

THERE is no unfailing rule. But a study of Professor Taylor's charts will furnish valuable hints. A line representing the price of corn is like a mountain range, with peaks of high prices, and valleys of low. In 1906, the peak was in the middle of the year—about July 1st, and was fifty-five cents high. The previous valley was about January 1st, and was down near forty cents. In 1907, beginning in January, when a low point of forty-five cents was reached, the price shot up to about fifty-seven cents by June, sagged a cent or two, and soared to about sixty-seven cents in October. Then the new corn beat it down to a broad elevated valley sixty cents high, where it hung until February, 1908, and then it rose in a regular Mt. McKinley to over eighty cents high in June, with a sharp little valley in July, falling to seventy-four cents, and another ascent to eighty-three cents in September. But it fell steeply so as to reach bottoms again in a sixty-cent valley in January, 1909.

Thence it rose steadily until it culminated in a broad peak seventy-seven cents above the zero level, in June. It dropped to rock bottom earlier than usual in 1909—about September 1st, when it touched the neighborhood of sixty-two cents—and rose to the sixty-seven-cent level by January 1, 1910, touching its highest point before February 10th.

This year—1910—was an abnormal one. Its "high" for corn was in January, and its "low" in June or July—the reverse of the ordinary. But it climbed to its usual peak in August—this time about sixty-seven cents—thence tobogganing to below fifty cents shortly after January 1, 1911.

The corn-grower who sold in midsummer in 1906 received about thirty-three and one-third per cent. more per bushel than did he who sold right after corn-gathering.

In 1907, the midsummer seller got around forty per cent. more than the January seller, and if he waited till the peak in October, he made more than that. Between January and midsummer of 1908 there was a difference of about twenty-two cents, in favor of summer.

From midsummer 1908 to date the market has been falling; but even on a generally falling market the price in midsummer 1909 was twenty-five per cent. higher than the low price in January. In 1910, the January market was about as high as at any time in the year, and the June and July price was lower by eight cents—conditions being about the reverse of the ordinary.

The rule, however, is, that prices are high in midsummer and low in midwinter. The seller of corn should study his situation and decide accordingly. These are the problems.

How much will the corn shrink in weight by drying, if kept till midsummer? How much spoilage and rottage will there be?

How much is money worth?

These problems require further examination. But it is safe to say that the man with sound, dry corn and good, dry, rat-proof cribs can, year after year, make good money by keeping his corn until June or July.

# Success in Marketing Poultry and Eggs

By John Lee Coulter

THE average American is appalled when he thinks of the size of some of the great American corporations. When he hears of millionaires and corporations with several hundred million dollars' worth of stock, he immediately thinks of something to be regulated by law. Indeed, the average American is accustomed to deal with small things, and yet this same average American is very much inclined to overlook many small things which, when considered in toto, are very important.

The average farmer has between forty and fifty chickens on his farm and it never occurs to him that this is an important part of his farm. But when we count the chickens on all of the farms, we find that the number exceeds a quarter of a billion. These chickens are worth altogether considerably more than a hundred million dollars, and this is too important an item to pass by as insignificant.

The number of poultry on American farms is not a true index of the total income from the poultry industry, because millions of chickens are hatched and sold and are never counted by the government authorities. During a single year probably a third of a billion dollars will not cover the amount of money expended for poultry by American consumers. If this is a true statement, it must be clear to any intelligent farmer that the industry is important enough to consider more carefully the many problems of marketing.

But the sale of poultry is only a part of the marketing problem. Probably a correct enumeration of the production of eggs in the United States during a single year would show a total production of very nearly two billion dozens. If these eggs were sold at twenty-five cents a dozen, the income would be \$500,000,000. Indeed, a recent estimate made of one year's income from poultry and eggs places the total annual receipts above \$1,000,000,000. If it is appalling to consider the business of some of the great American corporations, it must be equally appalling to consider this poultry industry. The question immediately arises, if all other business men find it to their advantage to organize in order to do their business, might it not be worth while for the farmers likewise to attempt some improvements in their methods of marketing the poultry products of the farms?

Mr. E. A. Pratt, in his book, "Transition in Agriculture," tells the methods used by the average farmer, or his wife, in the marketing of eggs. He tells how the average farmer carries a few mixed eggs in a basket to the country store for sale. The number is small, some of the eggs are poor in quality and there is a great variety or assortment in the same basket. There is absolutely no system in a great majority of cases. As a result the farmer is dissatisfied with the price which he receives and the consumer is dissatisfied with the price which he pays and the character of goods which he receives. An

organization of farmers can quickly take the business away from the farmers who have not organized.

The importance of system is clearly brought in a quotation from an English paper which recently came to my attention. It says in part: "Within the past few years there has been a marked falling off in the Cornish egg trade. At one time a large trader in the duchy used to supply eggs to the value of \$1,000 a week to a well-known London shop and to-day that shop does not take a single egg. Eight years ago Cornish dealers were sending eggs to London to the value of \$125,000 a year. To-day the sum returned for such products does not amount to \$75,000. The reason for this altered state of things is not, as some suppose, due to the smaller size of the Cornish eggs, because there is practically no difference between it and its successful rival from Denmark. Where the Cornish egg merchant damages his business is through his own carelessness. He will not study the requirements of the market. He will give no attention to uniformity, but will place large and small eggs, and also duck eggs, all in the same box. Whether they are fresh or not is evidently no concern of his. He will not wash a stained egg. On the other hand, the farmers of Denmark are most particular about these things. They place all of the eggs of one size together. They arrange the different shades and they see that every egg is fresh and clean. All this means saving to the shop man, together with the certainty of better prices and more trade."

Mr. Pratt, whose book was referred to above, tells us that in Denmark there are about four hundred egg societies which look after the selling of eggs for about 30,000 members. These societies save the members all trouble in the way of marketing and pay a fair market price. They also test and grade the eggs and guarantee a good product to the dealers and the consumers.

But Denmark is not the only country which has been able to systematize its method of marketing eggs. In passing we may refer briefly to the successes in Buda-

with the central organization. These societies send in between 12,000,000 and 15,000,000 eggs each year.

The old-fashioned way of getting rid of the surplus eggs in this country has been practised for the last hundred years. It has been either to take these eggs to the country store and trade them for groceries, or to take the eggs around from house to house and sell them to the consumers directly. Another way has been to collect the eggs during the summer months when large numbers are being produced, keep them until the winter season and sell them at the higher prices which prevail at that season of the year. The principal objection to this system is the fact that there are very few farmers who have facilities for keeping the eggs fresh for any length of time.

Very few farmers even have arrangements so that they can examine the eggs to see whether they are fresh when first collected. The individual farmer who attempts to store his eggs at the present time is not to be blamed, because the prices during the summer are extremely low and during the winter it is more nearly what it should be during the greater part of the year. But the farmers ought to have an organization to look after all of this work for them.

In every community where farmers have from twenty to fifty hens these farmers should organize in order to perfect the system of inspecting, storing, shipping and marketing their eggs. The society should be governed by a definite set of by-laws and all members should be required to live strictly up to the rules. On the other hand, the association should be ready to receive all eggs which the farmers have to deliver and should look after the handling of these eggs. With fifty farmers beginning such an organization, a fee of probably ten dollars ought to be enough to start the movement. If there are laws in the state which provide for cooperative societies, it would be well for the company to incorporate and sell stock. Shares of stock might be sold for from one dollar to ten dollars per share.

One important feature in the marketing of eggs by a society at this time is the work of marketing eggs in some way so that bad eggs will be identified. Either one of two methods can be pursued. One way would be for each member of the association to have a stamp with the date on it, as well as the number or letter which has been assigned to the farmer by the society. Each day all of the eggs collected should be stamped, or these eggs should be put up in cartons containing one dozen each, and the carton stamped with the date and the name of the farmer or his organization number. One of the children on an average farm could stamp all of the eggs produced in from one to five minutes each day without any difficulty. If the farmer does not have the eggs stamped, provision should be made requiring that he

[CONCLUDED ON PAGE 19]



How a case may be marked



Each egg bears a date and letter



There is profit in cooperation

pest. In 1897 the farmers who supply that city decided to establish a system of direct dealing with the consumers, and formed the Cooperative Marketing Society. There are about three hundred local societies connected

## In Quest of Fortune

### A Tale of Modern Farm Life And Its Sequel

By Thomas Buffum



THE sunlight beating hot  
On a twenty-acre lot,  
The shimmer of the heat across the plain,  
The hay that must be got,  
The swabbing of the sweat-drops  
On a face that's just a blot,  
The fear of being caught by sudden rain.

I am dreaming hard to-day,  
As I pitch the heavy hay,  
And my dreaming is of power, wealth and might;  
And in dreaming I am gay  
As I soldier out my day  
By an automatic working in an automatic way,  
And an automatic waiting for the night.



WHAT chance for my big brain  
On this eighty-acre plain,  
Where Beef and Brawn are constellations bright?  
What chance for mighty gain  
In the digging of a drain?  
Whoever found a fortune in the fencing of a lane?  
I'll take to town, become a man of might.

The garish grinding gloom  
Of the whited weaving-room,  
The dance of many loom-beams swinging past;  
The ratch and catch and boom  
Of the never quiet loom  
Makes a scene not like the tomb.  
A glimpse of shining shuttles, flying fast.



I AM thinking hard to-day,  
As I watch the shuttles play,  
And my thinking is of woods and winds and light,  
And my thoughts run grim and gray  
As I earn my daily pay  
By an automatic watching in an automatic way  
And an automatic waiting for the night.

Tearing toil for seven years,  
Heavy toll of hopes and fears,  
To build a place that no one else could fill.  
Yet now my viewpoint veers  
With the passing of the years,  
And sees me but a cog-point, easy spared among the gears.  
I'll hie me farmward: gulp the bitter pill!



BENDING belt of trees  
And a soothing summer breeze,  
A twitter from the swallows flying over.  
Fat cattle to their knees  
In a banner patch of peas,  
The dancing of the sunlight on the merry summer seas,  
The murmur of the mower in the clover.

I am working hard to-day,  
As I pitch the heavy hay,  
And my working is a mine of health and might.  
And in working I am gay,  
Without thought of daily pay,  
Or an automatic watching in an automatic way,  
Or an automatic waiting for the night.



THE years have come and gone  
Since that quiet summer morn  
When I joined that raging race for place and pelf.  
Though at times, from early dawn,  
I must toil at cows or corn,  
Though my bank-account is smallish and my face is weather-worn,  
I am happy—I am master of myself!





## Our Homeseekers' Excursions

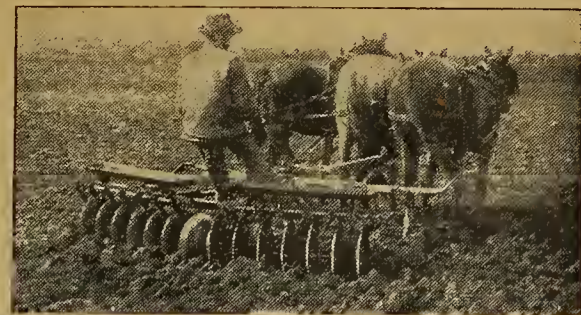

### VI.—Crops and Climate Along the Blue Ridge Mountains

#### North Carolina Lands

By W. A. Shay

SINCE coming here two years since, I have often wondered why people go west and north to locate on farms. One may cast about for some time before he finds the opening for a man to settle down and grow into money as fast as he could right here in western North Carolina, especially in the mountain district. With the spirit of his grandfather, who cleared his way into the wilderness, and one thousand dollars cash, a man can come here and in ten years be pretty well-to-do; of course, he must be willing to work, and work hard.

Here is the situation: an immense population, who have grown corn on the same patches for year after year, in some cases twenty years; corn is cultivated from one to three times during the season; rocks are never removed from the fields and stumps are left to rot out. This is the rule; there are a few exceptions, and those exceptions are making good. The fact that corn grows without care to from twenty to thirty bushels to the acre is all that need be said regarding the fertility of the soil. Corn frequently sells for one dollar per bushel. Just think of such a market right at your door!

When corn is quoted in the open market at from sixty to seventy cents, it sells right at home for one dollar, the difference is more than the cost of raising. Here, the only food known for the great American hog is corn. Some few people try raising corn to sell, but they do not raise enough for their own use. Hogs are not plentiful. When the Chicago market runs from seven to eight dollars for live hogs, the price of side pork, they call it bacon here, is from sixteen to twenty cents per pound, and it comes from the West. Do you see any connection? There is no community to my knowledge that uses so much pork on the average as this. The market is at the door of Carolina farmers.

Most cleared land has been corned to death, but timber-land is cheap. There is a railroad headed toward our particular section; it is coming as sure as anything, but at present we are ten miles from the railway. As soon as the railway comes, land will go up and the present opportunities will be snapped up. The neighborhood is all that could be desired, the citizens are quiet, peaceful and law-abiding; they do not understand agriculture as it is understood in many other places, for the reason that it is and has been so easy to get a living here. Their tastes have not become diseased and pampered with the delicacies of ultra-fastidiousness; "hog and hominy" are supreme.

No better fruit country lies out of doors. Apples from this state have taken the first premium at Madison Square Garden, and while they may not at present rival those from the State of Washington in appearance, they will far surpass them in quality and flavor. This is an admitted fact. And about the climate? Well, you have all heard of Asheville. George W. Vanderbilt liked it so well that he bought something over one hundred thousand acres and built immense lodges and mansions upon it, the whole costing him over one million dollars. Looks like he thought well of the climate. Long, cool summers and short, mild winters make the climate ideal. One can spend from nine to ten months out of doors without a coat on and sleep every night with a slight cover at this altitude; what better could be asked? If one likes hunting big game, there is bound to be sport to please him.

Right here I wish to say that this community owes a great deal to Mr. Vanderbilt for the plentifulness of game, and should show it by giving him a square deal.

A government bulletin says that for forty years the average depth of plowing in North Carolina has been four inches, with an average of about fifteen bushels of corn per acre. Last year the men on the experimental farms plowed three thousand acres and harvested a little over forty bushels to the acre. So it must be admitted that local practices in farming are not the best. They are improving, however, each year.

The mountain people are independent in politics to an extent that is, to say the least, very trying to the trusted politicians; the collar of a "boss" always galls the neck of one of nature's noblemen. Our country is ordinarily Democratic, but the congressman who was superseded by the present one was a Republican.

As to "furriners," which some of the unregenerate are pleased to call those who come from the North, I will say that as a "furriner" I have been very kindly received; no one could ask for better treatment anywhere. In the way of fences, I rather think we have the

advantage over Virginia. We have a stock law, so that the man who spends all his time hunting cannot with impunity pasture his cattle on the products of the labor of the man who does not hunt all the time.

If a man is honest in his conviction, he is as welcome to yell as much here about the conditions as he is anywhere else, so far as I know. Anyway, I have said considerable about road improvement. But this I have noticed in my former state, Michigan, and it applies to North Carolina, also: if someone wants road improvement, and the expense happens to hit some man who is satisfied with conditions as they were in his grandfather's day, there is nothing too mean for that man to say of the promoter.

There are no negroes here. Remember, I am speaking of the mountains of western North Carolina. If anyone cares to come to this section to make a home, he will find a people who are ready to receive him as God and his environment have made him.

Now, lest someone should be minded to rush to this favored region prematurely, let me say that it is hilly,

#### Tenants Conceal Possibilities

By Lynton Lloyd

A STRANGER coming here from a northern or western state, would see many things in our farming that would seem loose or defective to him. It would not be like the farming of his own section—would lack the method and the thoroughness which he had been used to at home, and if he were satisfied with a casual glance only, his impression would be that the agriculture of this part of Virginia is primitive, shiftless and very defective. And, in a sense, this conclusion would be correct.

But if the visitor would look further and observe more closely, he would discover the cause for this state of things. It arises from the tenantry system to which our landowners have been forced. Men with hundreds of acres of good land and no reliable laborer at command are obliged to accept the tenant, or let the farms lie idle. And the tenant, white or colored, is not seeking to make a good farm better, but to get all he can out of

it, at as little personal outlay as possible. He does not buy the best implements. He sets out no fruit-trees. He tile-drains no fields. He seldom resorts to clover or field-peas or other fallow crops. He keeps few stock, and seldom returns to the land much in the way of home-made manures. He goes heavily in debt in the spring for fertilizers to be paid for from his crops in December, and these only stimulate the soil unnaturally and consume the little humus therein, and thus leaves it, year after year, about as he found it, or a little worse—sometimes a good deal worse in actual fertility.

Under these conditions, it depends upon the character and industry of the tenant whether the landowner gets much material benefit from his broad acres. It is vain for him to fret, or turn one tenant away for another. He cannot compel obedience to his wishes. The tenant is free to move when he will, and it becomes a question of better something than nothing—and hence farming goes on in the loose and makeshift way common in the South.

Still there is much good farming carried on here. Men who work their estates themselves with hired labor that they can depend upon are making big money. These are practical men who know how to farm from having served a life-long apprenticeship at the trade.

After all, we are managing to live pretty well here in eastern Virginia. Our farms are improving. We are growing all the corn, oats, field-peas, potatoes (both sorts), cabbage and other garden truck, and hay and forage that we need for home consumption. We are growing four million bushels of peanuts yearly. We have plenty of the best bacon in the world. We are raising more cattle and sheep than formerly. Our millions of hens are shelling out the eggs liberally. Our supply of turkeys is enough to keep out imports. Our wild fruits fill up one to two hundred cans for the winter use of every family. Our forest wealth is annually building new farmhouses and adding to our comforts.

Our fur-bearing animals are not all extinct, and any young man who will turn his attention to it may make for himself, from this resource alone, from fifty to one hundred dollars every winter, for mink, muskrat, raccoon, otter, fox and beaver pelts.

This is a grand agricultural region, a land of great capabilities. The forest wealth in mold and rich manures is immense. The supply of marl, both Eocene and Miocene, is inexhaustible. There is some phosphate rock here, and near the large waters the supply of oyster-shells is enough to enrich every adjacent farm. Fish are plentiful in every stream. Timberlands are becoming great sources of revenue.

There is land here for sale, and prices are not extravagant. It is a good plan to rent the first year, and take time to look around before you buy. More than half the area of the country is yet in timber or brush. In fact, there is more land in timber now than there was a hundred years ago. If one has elbow-grease, he may clear the land and have a good farm in three years from the timber or brush. Come, there is room for you, whether you are Northerner or Westerner, providing you are enterprising.

EDITOR'S NOTE—This closes our Homeseekers' Excursions for this season. The editors can frankly say that these stories came from men who were guided neither by intense enthusiasm over the country, nor by bitterness caused by failure. Some spoke of conditions which were local, but the accounts came first-hand.

In considering the Blue Ridge country, W. F. Massey's account of Maryland, on page ten, is interesting.



Beautiful scenery surrounds the farming sections

exceptionally so; it is mountainous, the elevation at the post-office is 3,500 feet. Gold Mountain, at the base of which the road runs, is 6,000; Pisgah, on the other side of the river (Pigeon), is something over 5,600. So you will see that we have land that may well be called rolling. We are ten miles from the railroad, but there is a school within eighty rods of the house, and a church, in the other direction, less than fifteen rods; another about a half-mile. Land is cheap, some of it as low as three dollars per acre, and some as high as thirty. Some is good, some fair and some, of course, worthless; and one is unable to buy any size tract without including a

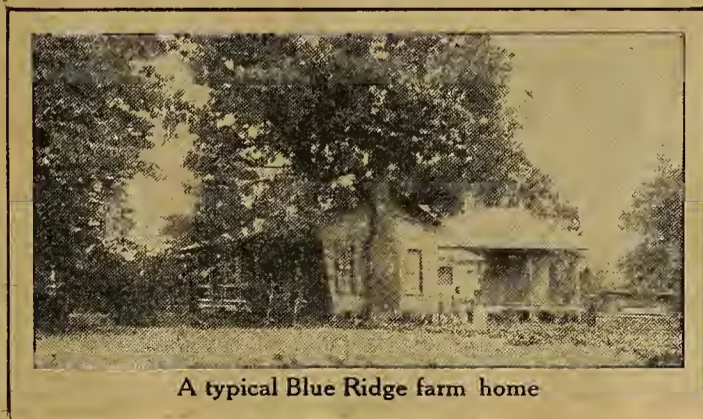

A typical Blue Ridge farm home

portion of the latter. These are the conditions as they exist in our part of North Carolina at this time.

It must be remembered that what has been said applies only to our part of the state. Some sections of North Carolina are quite different. But this difference is no more true of this state than it is a fact of other states. Statements that are made usually cannot apply to a very large area.

I do not know of any better opportunity for a big, husky young man who is willing to work hard than that beckoning him from western North Carolina.



You know how sap keeps a tree alive and strong and defensive against weather. Trinidad Lake asphalt does the same in

# Genasco

the Trinidad-Lake-Asphalt Roofing

The Kant-leak Kleet defends the roofing-seams against weather without cement. Prevents nail-leaks.

Ask your dealer for Genasco mineral or smooth surface guaranteed roofing with Kant-leak Kleet packed in the roll. Write for the Good Roof Guide Book and samples.

The Barber Asphalt Paving Company  
Largest producers of asphalt, and largest manufacturers of ready roofing in the world.

Philadelphia  
New York San Francisco Chicago

Get Ready for the Fairs Show the Best

There can be but One Best

Why lose profits breeding and feeding scrub hogs? Two of our O.I.C. hogs weighed 280 lbs. We are headquarters for breeders. Will send sample pair of our famous

O.I.C. Hogs

on time, and give agency to first applicant. We are originators, most extensive breeders and shippers of thoroughbred swine in the world and hold the unparal- leled record of having been established 47 years without losing a single hog by cholera or any contagious disease.

The L. B. Silver Co.  
1101 Citizens Bldg., Cleveland, Ohio.

We want to mail you our free book, "The Hog From Birth to Sale."

Send us your name

U. S. Gov't inspected herd.

FREE

Any owner of the stock, on request, will receive by return mail, charges paid, with no obligations whatever, 8 oz. sample pack- age of the celebrated Silver Live Stock Van- der, the well-known disease preventive and conditioner, with directions for its use.

## EMPIRE FENCE

Get the genuine EMPIRE big wire fence, direct, at wholesale. Save dealer's profits.

Big Factory, Big Sales, 23 Styles

No traveling salesmen, small expense, prices low. Every- thing guaranteed. Free samples by mail. Prices of leading styles freight pre- paid to all points north of the Ohio and east of the Mississippi River:—

Wires	Inches high	Medium Weight	Extra heavy (all No.9)
9	39	23c per rod	37c per rod
10	47	28c per rod	41c per rod
12	55	32c per rod	45c per rod

Special rates beyond this territory.

BOND STEEL POST CO., 42 E. Maumee St., Adrian, Mich.

10,000 High Lifts Saved

Electric



Easy work for you. Light draft for horses. The one unbreakable, low down hauler wagon. Steel wheels, all heights and tire widths. Save rutting. Send for free book on labor saving farm hauling.

ELECTRIC WHEEL CO., Box 13, Quincy, Ill.

## AUTO-FEDAN HAY PRESS

Only successful self-feed. 2 men can operate it. 20% less expense to operate. Record run 3 tons in 1 hour. AUTO-FEDAN HAY PRESS COMPANY  
1507 W. 12th St., K. C., Mo.

Just Hammer and Nails and You Lay This Steel Roof

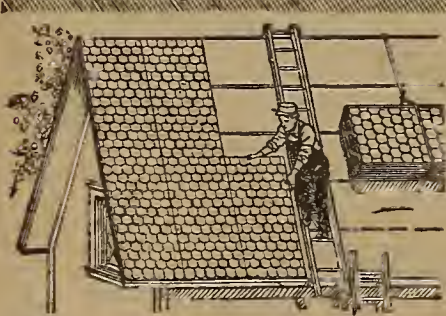

## Edwards "REO" Steel Shingles

One man can easily lay these everlasting steel shingles. Hammer and nails all that is needed. Our patent interlocking device covers all nails, thus preventing rusting, leaking, etc., and also guards against any expansion or contraction that might be caused by the weather. Our \$10,000 Guarantee Bond against light- ning protects you for all time against the destruction of your Edwards "Reo" Roof by lightning.

You can apply Edwards "Reo" Steel Shingles over old shingles or on sheathing 12 inches apart.

Send us the dimensions of your building and we will tell you the exact cost of material, freight pre- paid to your railroad station.

Special Money-Making Proposition to One Man in Each Community!

Write for it at once. Get our free Roof Book and select the handsome, most durable roof for your buildings.

Write for Free Standard Roofing Book No. 858.

THE EDWARDS MANUFACTURING CO.  
808-858 Lock Street, Cincinnati, Ohio. (62)

The World's Largest Manufacturers of Steel Roofing

# Three Cent Pork in the South

By Dan. T. Gray

Animal Husbandman, Alabama Experiment Station

**T**HE Northern farmer thinks of the South as being a section of the country where hogs are almost a curiosity on account of their scarcity. It is a fact that the South does not raise a sufficient number of hogs, but this is not due to the fact that conditions are unfavorable to hogs. Much of our meats are shipped in from western states, states that do not have the advantage of long grazing seasons, mild climate and cheap shelter. On account of the long grazing seasons, mild climate and cheap shelter, the South can make pork more cheaply than it can be made in the North.

The southern farmer is rapidly introduc- ing hogs into his system of farming. The inquiry for pure-bred boars is a large and continuous one. There is probably not a breeder of pure hogs in the South who has not had, during the last three years, twice as many orders as he could fill. Our farmers are wanting good boars and sows, and a great number of these good animals are being shipped in from the North. The writer knows of one locality in Alabama where more than two car-loads of pure-bred hogs have been brought in from the North the last year. Several influences are bringing this change about. First, our farmers are now realizing that we have exceptional advan- tages for hog production. Green pastures can be had the year around by planting some temporary winter crops, and by the use of these pasture crops we have learned that we can easily make pork for three cents a pound. Second, the boll-weevil is advancing and overrunning more and more of the South each year: this pest forces the farmer to add crops to his farming operations in addition to cotton, and the hog is the most satisfac- tory addition. Third, the hogs are animals that can be introduced upon almost every farm of the South. He is well adapted to both the large planter and the small farmer. The sow is a rapid producer. Money is

The hog in its wild state is omnivorous, feeding upon roots, nuts, fruit, worms, fish, grass, snakes, etc.; in fact, but few feeds can be mentioned that he will not eat if he be given the opportunity. In the South, the old feeding custom is to enclose the hog in a small, dry pen when the fattening period arrives and feed nothing but corn. Our best farmers, though, have long since learned that our domesticated hogs have inherited the tendency to select their feeds from a variety of substances, and when enclosed in a pen and given but one feed, they are not allowed to reach their highest possibilities.

### Corn Alone is Not Profitable

There is an abundance of experimental data to show that pork cannot be made profitably when raised and finished upon corn alone, or, at least, cannot be made as profitably as it can be made when the corn is fed along with certain other feeds. The Alabama Experiment Station has published results which show that when corn is worth seventy cents a bushel, and is fed alone, the cost of each pound of gain will be just about seven cents; when corn is selling at sixty cents a bushel, each pound of gain put on will cost six cents; when corn is worth fifty cents a bushel, each pound of gain will cost five cents, and when corn is worth only forty cents a bushel, pork can be finished for only four cents a pound. It appears, therefore, that when seventy-cent corn is fed to five-cent hogs, the feeder is losing twenty cents a bushel on the corn. No farmer can afford to feed corn alone to his hogs; he could not afford it even if the corn should sell at twenty cents a bushel.

Many farmers, when they learn that corn alone is an exceedingly unsatisfactory feed for hogs, wonder what can be used along with the corn to increase its value. Fortu- nately for the South—and the North, too—it is not necessary to depend upon corn



Hogs fed by the Alabama Experiment Station. The lot shown on the left grazed on rape pasture from November 9 to May 3. The other lot was fed on rye pasture and corn for the same period. The pork was made in winter. Cost three and one-half cents per pound

turned rapidly, and that is what our farmers want. There is no question at all in the writer's mind but that the South will, in time, be the great hog-producing section of this country. The conditions are almost ideal.

### How Southern Hogs are Fed

Four or five years ago it was often claimed that hogs could not be raised and finished at a profit in the South, since corn was selling around one dollar a bushel. Our farmers were often told that they could buy their pork cheaper than they could make it. Our farmers believed these statements for several years, but when salted side-meat began to sell for eleven to thirteen cents a pound, they began to have serious thoughts about the cost of the meat if they should make it upon their own farms. In the South corn sells for much more than it does in the North; this discouraged our farmers for years, for they thought that they could not compete with the great Northwest, where corn sells for from thirty to fifty cents a bushel. Our farmers realized the fact that they could not compete with the North in making pork if they followed the feeding-plan laid down by the northern farmer. Up there, they fed corn alone and still made pork at a profit; down here in the South, this method of feed- ing could not be followed, on account of the high price of corn.

So our farmers began to try other feeds along with corn. They at first thought that there was no other feed equal to corn for pork production. But they began to study the work of the experiment stations and soon learned that when corn is fed alone for any length of time there are few feeds which are poorer. But they also learned that when corn is fed in combination with other feeds its use is to be highly commended, and can be used to a great economical advantage, too, even though it sells upon the market as high as one dollar a bushel. The hog is not adapted to living on corn alone, and when we require it of him we are forcing him to do a thing which is not consistent with his nature. Men like a mixture of feeds as a change in diet; so do the lower animals.

alone. In the South, many concentrated feeds, as skim-milk, shorts, tankage, cotton- seed meal, rice-polish, etc., can be used along with the corn. Many of our farmers, however, do not depend upon the concen- trated supplements at all—and still make pork at a great profit. It is still more for- tunate for the South that it can have pastures and grazing areas the year around. And the majority of these green crops are suitable for hogs. This section is wonder- fully blessed in the great variety of both concentrated and pasture feeds. On account of this fact we are in position to make pork cheaper than any other section of the United States.

### Concentrated Supplements

As a general statement, it may be said that almost any concentrated feed, when used with corn, will make pork cheaper than when corn is fed alone. But there is at least one concentrated supplement that the southern farmer should become acquainted with. The feed referred to is tankage. The farmer who cannot arrange grazing areas for his hogs should be especially interested in tankage, as it is a very valuable feed to go along with corn. Tankage is extremely rich in protein and ash; corn is naturally poor in both protein and ash. Tankage is a slaughter-house by-product and can be secured from either the larger packing-houses of the North and West, or from the smaller packing-houses and abattoirs of the South. As it is an extremely rich feed, it should be used in small amounts. The Alabama station recently tested the value of tankage when fed along with corn. One lot of hogs was fed corn alone for 110 days. A second lot of hogs was fed a ration of corn .9 and tankage .1 for the same length of time. The corn-fed hogs made an average daily gain of only .198 of a pound daily, while the tankage-fed pigs averaged .972 of a pound each day. The pigs averaged about 45 pounds in weight when the test began. If they had been larger hogs, the corn would have been more satisfactory. When corn is valued at 70 cents a bushel, each 100 pounds

**WHITE LEAD on THE FARM**  
Run Down Places  
Don't let your buildings run down—any more than your land—both of them are your capital. Nothing makes a farm appear more neglected and down-at-the-heel than unpainted buildings. Paint mixed on the job and made of  
**"Dutch Boy Painter"**  
Pure White Lead  
and pure linseed oil will not only make your build- ings look prosperous but will protect them from the weather as no other paint can. It is the most economical paint in the world because it lasts so long. Paint now and keep out the winter's storms and frosts.  
**Our Free Painting Helps**  
We will send you free, on request, color schemes and miscellaneous paint- ing instructions that you will find of real practical value. Ask for Helps 1247.  
**NATIONAL LEAD CO.**  
New York Cleveland Chicago St. Louis Boston Buffalo Cincinnati San Francisco (John T. Lewis & Bros. Co., Philadelphia) (National Lead & Oil Co., Pittsburgh)

### A Leading Woman's Magazine WITHOUT COST

The Woman's World is, without doubt, the best magazine ever printed for the money; in fact, is superior to many magazines selling for more than this. It is not only attractive in appearance, but its columns are full of the choicest litera- ture that money can buy. The contents of the Woman's World are selected with a view of entertaining and educating its readers. It is a big value at a low price. Every farmer in the country should take this opportunity of obtaining the Woman's World without cost in connec- tion with FARM AND FIRESIDE.

You can get the leading medium-priced woman's publication for two whole years without cost by extending your own subscription to FARM AND FIRESIDE one year.

Farm and Fireside, one year  
regular price 50 cents } Both for  
Woman's World, two years 50 cents  
regular price 50 cents }

Send your order at once to  
**FARM AND FIRESIDE**  
Springfield, Ohio

### BALE 18 TONS A DAY HAY

Our "Cyclone" 3 stroke self feed hay press is the latest, most powerful and most efficient press on the market. Each circle of the team presses in three charges. The self feed automati- cally puts the hay to the bottom of the bale chamber. These improvements wonderfully increase capacity of our presses. Write today for circular K-146 which gives prices and details of five days' free trial.  
**GEORTEL CO., QUINCY, ILL.**

### SAVE "GET IT" MONEY

The Common-Sense Conveyor does the work and costs half the money. It's inexpensive, practical, and the easy way to fill silos. **SATISFACTION AND PROMPT SHIPMENT GUARANTEED** Write now for our "Direct from factory" to you—Special Price!  
**Common-Sense Conveyor Co.**  
305 Factory St., Boonville, Indiana

### CIDER PRESSES

The Original Mt. Gilead Hydraulic Press produces more cider from less apples than any other and is a **HIG MONEY MAKER**. Sizes 10 to 40 barrels daily. Also cider evaporators, apple- butter cookers, vinegar generators, etc.  
**CATALOGUE FREE.**  
**THE HYDRAULIC PRESS MFG. CO.**  
126 Lincoln Ave., Mt. Gilead, Ohio.

### FREE

Literature will be sent to anyone in- terested in the wonderful Sacra- mento Valley, the richest valley in the world. Unlimited opportunities. Thousands of acres available at right prices. The place for the man wanting a home in the finest climate on earth. No lands for sale; organized to give reliable information. Sacramento Valley Development As- soc'n. SACRAMENTO, California

### BINDER

Attachment with Corn Harvester cuts and throws in piles on harvester out- rows. Man and horse cuts and shocks equal with a Corn Binder. Sold in every state. Price \$30 with Binder Attachment. S. O. MONTGOMERY, of Texline, Texas, writes:—"The harvester has proven all you claim for it. With the assistance of one man cut and bound over 100 acres of Corn, Kafir Corn and Maize last year." Testi- monials and catalog free, showing pictures of harvester.  
**NEW PROCESS MFG. CO., SALINA, KAN.**

### Indiana Veterinary College

Graduates eligible for U. S. Bureau of Animal Industry, U. S. Army veterinarians and for private practice. Teaches every branch of veterinary science. Catalogue. F. A. MUELLER, Sec., 808 E. Market St., Indianapolis, Ind.  
**ARKANSAS LAND** 17,000 acres farm and fruit lands for sale \$10.00 to \$20.00 per acre. Booklet free. Agents wanted, Geo. R. Lochrie, Gifford, Arkansas.

of pork cost \$9.15 in the corn-fed lot, and only \$5.58 in the tankage-fed lot (tankage \$40 a ton). It was learned in this test that 42 pounds of tankage took the place of 353 pounds of corn. The 42 pounds of tankage cost only 84 cents; the 353 pounds of corn was valued at \$4.41, or an investment of 84 cents in tankage saved \$4.41 in terms of corn, or, expressing it in other terms, one ton of tankage was equal to 300 bushels of corn in these tests.

Among the various concentrated supplements which can be used with corn for raising and fattening hogs are the dairy by-products. At the present time the South has but little dairy by-products to use in finishing hogs, but as the dairy business assumes greater proportions much larger amounts of these valuable feeds will be at the disposal of the feeder. In the North great amounts of skim-milk are at the disposal of the hog-feeder, and it is safe to say that the best and most profitable way to sell this skim-milk is through hogs. Probably the skim-milk and buttermilk could be used to best advantage in feeding the small pigs and the suckling mothers, as green pastures take their place after the pigs are weaned; but still there are many cases where they should be fed to the fattening pigs. Many farmers and many experiment stations can testify to their value. To illustrate: The Alabama station fed two lots of pigs. One lot received nothing but corn. A second lot was fed corn along with skim-milk in the proportion of one part corn to two and one-fifth parts skim-milk. The gains in the corn-fed lot cost \$8.38 per hundred, while the same gains in the skim-milk-fed lot cost only

can be used? The Alabama station has done several years' experimental work along this line; many pastures have been tried. Rape, cow-pea, soy-bean and peanut pastures have been used with the greatest satisfaction. This far south the rape-pasture is used as a winter grazing plant; there is no reason at all why it should be used as a summer plant. The rape-seed should be planted in September, or early part of October; when thus planted, the crop will be ready for grazing within forty days from the time of planting. As a result of its use, the land is kept busy the year around, as it comes off early enough in the spring for the common summer crops.

**Remarkable Results in Winter**

Three winters ago the Alabama station grazed some hogs upon a rape pasture. The area was grazed twice, as the peanuts grew up behind the hogs after the first grazing, and as a result of both grazings it was learned that one acre of rape was equivalent to 62 bushels of corn. The pasture was on land that would produce about 20 bushels of corn to the acre. Or, when hogs sell for only 5 cents a pound, each bushel of corn that was fed the hogs was sold, through the hogs, for 96 cents the first grazing and \$1.36 the second grazing. The southern farmer should remember, too, that these results were secured in the winter-time, just the time of the year when the average farmer is getting no returns from his lands at all.

Many summer-growing pastures can be used, but the writer will call the reader's attention to only two. Peanuts rank among the exceedingly valuable hog crops. Some

lot, which grazed the same pasture and had a three-fourths ration of corn along with it, gained 1.3 pounds daily. When corn is valued at 70 cents a bushel and the crop at \$8 an acre, it cost \$7.61 to make 100 pounds of pork on the corn-fed hogs, \$2.59 on the soy-bean pasture plus one-fourth corn, \$3.36 on the soy-bean pasture plus a one-half ration of corn and \$3.17 on the soy-bean pasture and the three-fourths corn-fed hogs; or the use of the pasture more than cut the expenses in half in every case.

In this work the point was thoroughly brought out that the farmer cannot afford to sell his corn at the usual market price. Much more money can be secured for it when it is first fed to hogs. Where the hogs received a fourth ration of corn along with the soy-bean pasture, the corn was sold for \$4.33 a bushel when hogs sell at 7 cents a pound. When a half ration of corn was fed with the pasture, each bushel of corn sold for \$2.18. Where a three-fourths ration of corn supplemented the pasture, \$1.93 was secured for each bushel.

In conclusion, the writer would recommend the following as a crop system that the farmer can follow out to great profit: Plant soy-beans and peanuts from May 1st to June 1st. The soy-beans will be ready to graze by August 15th. They will afford grazing for at least 60 days, when the peanuts will be ready. Turn the hogs onto the peanuts and graze until the crop is exhausted. Feed some corn along with the crops. When the peanuts are exhausted, the hogs should be enclosed in a dry lot for from about 21 to 28 days and fed on a ration of corn two thirds and cotton-seed meal one third. The gains during the short dry-lot period are made rapidly and economically, and the cotton-seed meal hardens the meat and fat rapidly. But do not feed the cotton-seed meal for more than 28 days, as it is a dangerous feed when used for more than that length of time. If the hogs must be carried longer, discontinue the use of the cotton-seed meal and feed ahead on corn, or corn and shorts.

EDITOR'S NOTE—Corn-belt swine-growers may take warning from these statements. The South is going into hogs. There is no question about that. The North must produce hogs more cheaply on the average, or eventually the supremacy will leave the now-famous corn-belt.

**Liberality**

SIGHED a farmer whose methods were narrow: "I never shall fatten that barrow!" Said the pig with a grunt: "I've been fed like a runt From the day I was only a farrow."



A soy bean pasture in Alabama which enabled the feeder to make pork for less than three cents a pound

\$4.02 (corn 70 cents and skim-milk 30 cents per hundredweight). The Tennessee station carried through a test in which the value of skim-milk was tested. The first lot of pigs was fed corn alone. The second lot was fed corn and skim-milk in the proportion of one part corn to four parts skim-milk. It cost \$15.79 to make 100 pounds of pork in the corn-fed lot and only \$4.56 to make the same amount of pork in the skim-milk-fed lot. Corn and skim-milk were valued as above. Too much skim-milk should not be used. The correct proportion is about one part corn to three parts skim-milk.

**Temporary Pastures**

All of the concentrated feeds mentioned are good and should be used, but still no farmer is upon a safe hog basis who depends altogether upon grain feeds for his hogs. Concentrated feeds of all kinds are high in price, especially so in the South. In fact, they have been so high in the South that our farmers have been forced to look for cheap feeds to go along with the concentrated ones. Our aim here is to save as much of the concentrated feeds as possible. In casting about in search of cheap feeds we have finally become satisfied that pasture crops are the salvation for the hog-farmer. Without pasture crops we all know that the hog business is upon an unsafe basis. With pasture crops we know that the hog business is upon a safe and sound basis, even though the price of hogs should go down to four cents a pound again. Until the farmer sees his way clear to make a good, permanent pasture, or has one already made, he should keep out of the live-stock business. Pastures come before hogs, or should, anyway. It is true that the South, the very place where they can be made easily, is sadly deficient in pastures, but our best farmers are now making extensive use of them. In fact, many of our farmers fatten hogs now without the assistance of a single ear of corn. In the North, bluegrass pastures would, of course, be used. In the South, Bermuda grass takes the place of bluegrass.

But no farmer should stop with the establishment of the permanent pasture. This is only a beginning. A system of temporary pastures should be planned to reinforce and supplement the permanent pastures. It is upon these temporary pastures that the hogs will be fattened, while the sows and the pigs will largely be run upon the permanent pastures. Now what temporary pastures

sections of the South are even now using the plant very extensively. In parts of Alabama the hog receives no corn at all during the fattening period. Both the Arkansas and the Alabama stations have done experimental work with the peanut-plant. In one Arkansas test one acre of peanuts proved to be equal in feeding value to 86 bushels of corn, in another test to 53 bushels and in a third test to 51 bushels. When it cost \$8 to make an acre of peanuts, pork cost 63 cents a hundred in the first test, \$3 a hundred in the second test and \$3.02 in the third test. In an Alabama test one acre of peanuts took the place of 57 bushels of corn, or, when corn is valued at 70 cents a bushel and the crop of peanuts at \$8 an acre, it cost \$3.18 to make 100 pounds of pork. In a second Alabama test, one acre of peanuts took the place of 78 bushels of corn, or each 100 pounds of pork cost \$3.07. These results were all secured on poor, sandy soils. In the South, the peanuts can be made ready for grazing by July 1st, and where the large varieties can be grown, the grazing can be continued throughout the early winter months.

**The Place for Soy Beans**

Another leguminous crop that is an exceedingly valuable crop, both for hay and for use as a pasture for hogs, is the soy-bean. It will grow in both the North and the South. This crop can be planted any time, from April 15th to July 1st in the South. It is ready for grazing about 90 days after planting, and the grazing period can be prolonged over about 80 days. Hogs will make excellent gains upon this pasture without corn as a supplement, but it seems that it is more profitable to use some corn along with the pasture. The Alabama Experiment Station has used this plant for several years as a hog-feed, and has made pork for less than three cents a pound as a result of its use. In Bulletin No. 154 of the Alabama station are reported results where a corn-fed lot of hogs was compared to three other lots which received different amounts of corn along with soy-bean pasture. The corn-fed hogs made an average daily gain of only .375 of a pound. The second lot of hogs, which had the run of a soy-bean pasture plus a fourth ration of corn, made an average daily gain of 1.1 pounds. A third lot of hogs, which were grazed upon the same pasture and had a half ration of corn, made an average daily gain of 1 pound. A fourth

**BEST RECORD Ever Made by Any Cream Separator. Only A SHARPLES Could Do It.**

We have repeatedly told you that Sharples Dairy Tubular Cream Separators wear a lifetime. One of our regular hand-driven Dairy Tubulars, of 500 pounds capacity per hour, recently finished work equal to 100 years' service in a five to eight cow dairy. Total cost for oil and repairs only one dollar and fifteen cents. This Tubular is free for all to inspect who visit the world's greatest separator works. Ask us to mail you the fully illustrated record of this great demonstration of Tubular superiority. See how the parts of this Tubular resisted wear. Tubulars are guaranteed forever by America's oldest separator concern.

Tubulars outskim as well as outwear all others. Have twice the skimming force. Skim faster. Skim twice as clean. Dairy Tubulars contain no dials.

You will finally have a Tubular. Get the Tubular first. You can try it without paying one cent for freight or anything else. Other separators, exchanged for Tubulars, are simply pouring in. Exchange yours. Write for catalogue No. 112

**THE SHARPLES SEPARATOR CO.**  
WEST CHESTER, PA.  
Chicago, Ill., San Francisco, Cal., Portland, Ore.  
Toronto, Can. Winnipeg, Can.

**NEWTON'S HEAVE COUGH, DISTEMPER AND INDIGESTION CURE**

The Standard Veterinary Remedy. 21 years sale. Send for booklet.

SAFE TO USE BEST CONDITIONER

Makes the horse sound, stay sound

**DEATH TO HEAVES**

The first or second \$1.00 can cures Heaves. The third can is guaranteed to cure or money refunded. \$1.00 per can at dealers, or express prepaid.

**THE NEWTON REMEDY CO., Toledo, Ohio**

**We Prepay All Delivery Charges**

to any railway station in the United States on a greater variety of merchandise than any other store in America.

Our Delivered Price on Ready-to-wear Apparel, (excepting shoes) for all the family is just the same to everyone, whether your home is in California or in New York. Distance makes no difference. You can buy just as easily, just as satisfactorily, from the Macy Catalogue, as if you were to visit the famous Macy store in person, and the Ready-to-wear Apparel (excepting shoes) you select will be delivered anywhere, with all charges prepaid by us. This broad, liberal policy in connection with our guarantee of satisfaction or your money back, will surely make many thousands of new friends for us this year, and we hope you will be among them.

**New York Styles Are the Newest New York Prices Are the Lowest**

Every woman knows that New York is the fashion center of America, and Macy's is the largest and best New York City store. Our big free Catalogue offers you the latest New York and European styles months in advance, the very finest things in Ready-to-wear Apparel of every description for every member of the family, at prices much lower than those asked by other dealers, at home or elsewhere, for equal quality. Macy's sell only merchandise of the best qualities, and Macy's New York Store is famous as the most economical shopping center in America. More than 250,000 critical New York shoppers pass through our aisles in a single day, and if these discriminating buyers find Macy's the best place to supply their wants, surely you will find it the most satisfactory place to supply your wants, too.

The Macy Catalogue, now ready, quotes you a delivered price on thousands of articles you will need this Fall, and it shows such wonderful varieties in every line of merchandise required in every American home that you ought not to buy anything for Fall or Winter until you write for this Free Catalogue, and look through its pages. You can live better, and at lower cost, with this book in your possession, because it establishes the standard of quality you should get and the price you should pay. Just write us a letter or a postal card and say, "Please send me a copy of your new Fall Catalogue," and we will send it to you by return mail, free and postpaid.

**R. H. MACY & CO.**  
700 Macy Building, New York

Our Big 600 Page Free Book Offers You

- Dresses, Skirts
- Shirt Waists
- Tailored Suits
- House Gowns
- Fur Coats
- Fur Sets
- Tourist Coats
- Automobile Accessories
- Muslin Underwear
- Knit Underwear
- Gloves
- Men's Suits
- Men's Overcoats
- Men's Underwear
- Men's Furnishings
- Men's Gloves
- Girls' Dresses
- Girls' Coats
- Girls' Underwear
- Boys' Suits
- Boys' Overcoats
- Boys' Underwear
- Infants' Dresses
- Infants' Caps
- Watches, Jewelry
- Umbrellas
- Belts, Shoes
- Ostrich Plumes
- Feather Boas
- Laces, Silks
- Dress Goods
- Hosiery, Pipes
- Smoking Materials
- Silverware, China
- Cut Glass, Notions
- Carpets and Rugs
- Lace Curtains
- Sewing Machines
- Pianos, Books
- Stationery
- Cream Separators
- Stoves and Ranges
- Kitchen Utensils
- Baby Carriages
- Hardware, Drugs
- Groceries

— in short, everything for the American home in the famous Macy quality, at surprisingly low prices. Ask for your free copy of the book today — right now.

## How a Mother Brought Her Daughter To Disgrace

She was a careful mother, too, or believed she was: of good family and social position, and the girl was what we call "a nice girl." Yet, the mother awoke one morning amazed to find "her girl" in jail and disgraced. The girl was as astonished as was the mother. And the author says, who tells the story: "Thousands of mothers are doing exactly for their girls what this mother did, only they don't know it." But they should know it, and it will surprise many a mother to read how she is doing it. It is a graphic story, true to life, forcibly told, and with a ring in it that strikes no uncertain sound.

Read it in the September LADIES' HOME JOURNAL.

15 Cents Everywhere

## How Can I Make a Cat Stretch Itself On the Stage Every Night?

That is what puzzled David Belasco. He wanted to give a domestic touch to a play: If he could only get a cat to come on the stage at a particular point in the play, stretch itself and lap a saucer of milk. But how to make a cat stretch every night at a given time? He puzzled over it for days. Then an ingenious idea struck him, and every night for 400 nights he made a cat stretch. It made the success of the play. Read how he did it. You never would have thought it possible.

"Little things like that have made my plays successful," says Mr. Belasco. Then he tells of the "little things," all in an article, "Why I Believe in the Little Things." It is a picture "behind the scenes"—but it is more.

It is in the September LADIES' HOME JOURNAL.

15 Cents Everywhere

## Headwork Shop Perfected Pointers from Practical Persons

### Let Jack Do It

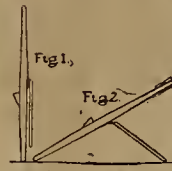

HERE is much the handiest buggy and spring-wagon jack I ever used. It adjusts itself to any height of axle. Take a piece of scantling about six feet long, one-and-one-half inches thick, by three inches wide, dress off and taper at each end, with the handle end made round and smooth.

Spike a block (see sketch) on one side about eight inches higher on scantling than axle. Then take a piece seven-by-two-and-a-half inches and fasten to scantling with old strap-hinge six inches above block on other side. It will lean up in the corner like a handspike when not in use, as in Fig. 1. To operate, place in position of Fig. 2, slip under until axle comes above block, then lift on end of handle like handspike, and the piece hinged on will follow up and hold any height desired.

J. B. STEERE.

### Watch Them Grow!

TAKE a barrel. Put in a wheelbarrow-load of manure and fill the barrel with water. Stir well and let stand until soaked. Then take long-necked bottles and fill with the liquid manure. Place the necks of the bottles in center of cucumbers, melons or squashes, and watch results. Repeat as often as desired.

MRS. A. M. WHITE.

### Kink for Rhubarb-Raisers



TO MAKE rhubarb tender, to keep it off the ground, and to conserve moisture about the roots, grow each hill inside half a barrel as shown in sketch. Take a strong apple-barrel, remove the heads and, after nailing the staves to the hoops, saw it in two. In case the rhubarb is quite short, cut the barrel into thirds. Place each section over a hill of rhubarb.

Since the segment of the barrel shuts off light from the side, stalk growth is greatly encouraged and the increased rapidity of growth results in crisp and tender rhubarb. Plants on side hills are also protected from being covered by surface washing of the soil. The reduced amount of labor in caring for the plants and other benefits derived far outweigh the cost of the barrels.

D. S. BURCH.

It is the farming we do now that helps us to do better next year.

### Float Valve for Drinking-Tank



FLOAT (A) is a soft-wood board two feet long and one inch narrower than trough. "B" is a block nailed to float (A) with a soft rubber or felt pad on end next to end of pipe (C) by which water is conveyed to trough.

The float is held in place by two one-half-inch picture-frame eyes screwed at each edge about four inches from end of float and one inch from edge, and through which a one-half-inch rod (F) is inserted. Have end of pipe smooth and adjust trough so that padded block hits square, so it will stop water entirely when float rises to desired depth.

Float must be covered to keep stock off. The partition should not go to bottom of the trough. As the water goes out, float drops and in comes more water.

### Tight Grain-Bed

THREE grain-beds like the one described below will haul grain to market, three miles away, as fast as it can be thrashed. And this method saves sacking the grain and the labor of three hands at the machine.

Length, fourteen feet; height, twenty-one inches; width, five feet eight inches; capacity, one hundred and forty bushels of oats, sixty-five bushels of corn, one hundred bushels of wheat. Any hay-rack can be used and the grain-bed made to fit it, but mine is of the above dimensions. The hay-rack bottom should be made tight, if not already so.

The sides are made of six ship-lap boards, three on each side, fastened together and made secure to the bed by three wagon-bed irons extending through the hay-rack bottom, where nuts screwed on the irons make the sides tight. The endgates are made of ship-lap boards, three of them, each six feet long. One sixteen-foot piece for endgate cleats, and two one-half-inch rods running through each end, and the box is completed. If the work has been carefully done, there will be no leaks.

C. M. DECK.

### For the "Puller"



HERE is a humane method which I know from experience will hold with ease any headstrong horse.

Fasten a ring (R) in each end of an inch strap (AA) three feet long. Place this over the horse's head with each end through the bit-rings. Now fasten the lines to the rings of this strap.

By this arrangement the bit acts as a pulley and is drawn up into the mouth. This strap works well with any straight bit. A jointed bit will not do.

A. M. BESEMER.

### Smoke-House in Thirty Minutes

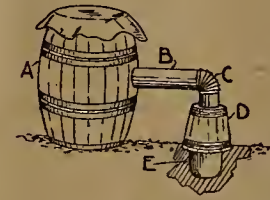

IN MAKING a smoke-house last fall, I first took an old iron kettle (E), to build a fire in, and dug a hole in the ground large enough to let the kettle down just even with the ground. I took a sap-bucket (D) and turned it over the kettle, bottom side up, and cut a hole in the bottom of bucket large enough to take a stove-pipe elbow (C). A barrel (A) and one length of stove-pipe (B), used as a connection between stove-pipe elbow (C) and the barrel, completed the device. I covered the barrel with old carpet to keep the smoke in. This worked like a charm in smoking meat in the absence of a smoke-house.

HARRY RASZMANN.

### One-Man Gallows

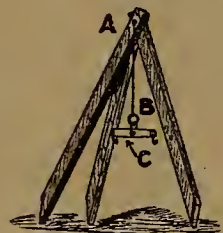

TAKE three pieces of two-by-four, eight feet long, tapered at both ends, and bolt as in sketch at A. Fasten singletree (C) to ring (B) which hangs by a rope from A. By spreading out the legs of this tripod, the singletree is lowered and hooked to beef or pork. Then pushing the legs up, one at a time, raises the carcass.

W. W. WOMBLE.

### New Dashboard

MANY a buggy or spring-wagon looks bad because the dashboard leather is ripped or full of holes. This can easily be remedied and made to look and wear almost as good as new for about twenty-five cents or less.

Get a piece of tin or galvanized sheet-iron about three times the weight of common stove-pipe tin. This sheet of tin must be the size of frame iron and one-fourth inch longer. Cut or chisel out the corners carefully and crimp tin and dash-frame iron with riveting-hammer. Trim rough corners with a file, drill holes for bolts and give two coats of good black buggy-paint. You have a dashboard that looks fine and that will stand rough usage under any weather conditions.

ROBERT KRENZIER.

### Eggs Are Safe

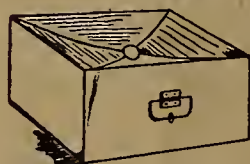

HERE is a box I have used with satisfaction in preventing hens from eating eggs. Take a square box and cut a place in the side large enough for your hand to go through and a little above the middle, then fasten the piece, sawed out, with a hinge. Now fill the box with straw just a little above the hand-hole. Over the top of the box tack a stout piece of cloth and allow to lay almost to the straw. Cut a hole in the center of cloth for an egg to pass through. When the hen has laid, the egg rolls through the hole into the straw. If more than one hen lays in this box, the eggs will not break one another, as the fall is too short.

J. F. BAKER.

### A Float, or Leveler

TAKE two pieces, four-by-six inches and sixteen feet long, bolt together four feet apart with five pieces of two-by-fours, four feet long on top. Then put a bottom on the underside of the two-by-fours out of one-inch boards. We cut a notch every six inches in the front four-by-six. This makes it hold better and works the soil more and deeper. A machine like this levels the field in fuc shape. It puts a fine finishing-touch to the seed-bed.

T. W. KEITHLY.

## Crops and Soils

### The Man Behind the Plow

THEY sing about the glories of the man behind the gun, And the books are full of stories of the wonders he has done; There's something sort of thrilling in the flag that's wavin' high, And it makes you want to holler when the boys go marching by; But when the shoutin's over and the fightin's done, somehow, We find we're still dependin' on the man behind the plow.

IN ALL the pomp and splendor of an army on parade, And through all the awful darkness that the smoke of battle made, In the halls where jewels glitter and where shoutin' men debate, In the places where rulers deal out honors to the great, There's not a single person who'd be doin' business now, Or have medals, if it wasn't for the man behind the plow.

WE'RE a-building mighty cities and we're gainin' lofty rights, We're winning lots of glory and we're settin' things to rights, We're showing all creation how the world's affairs should run; Future men will gaze in wonder at the things we have done, And they'll overlook the feller, just the same as we do now, Who's the whole concern's foundation—that's the man behind the plow. S. E. Kiser.

How many have read the little poem at the beginning of the column? If you have not read it, do so now. There is more truth

Every man with a keen, observant eye can go through the country, regardless of the time of the year, and pick out the men who are good plowmen. Do not forget that you are being judged almost daily by your fellow men, from the work you are doing and have done. You cannot cover your work; be it good or bad, it stands for itself.

The essential of good plowing is sufficient power to draw the plow at a steady, even gait. The size of the plow matters but little, it is the power one has in comparison to the soil turned over that counts. Without sufficient power only poor work can be done. One of the best and most practical powers, and the only one considered in this article, is horse-power. For continued good result year after year it takes straight, even, deep plowing, and to do this work it takes heavy draft-horses. Many a man will say, "Give me a one thousand or twelve hundred pound horse for farm work," but one thousand to twelve hundred pound horses are not "in it" when it comes to real good plowing and where the work is done as it should be done. It takes too many of the light horses on a plow where one has to plow day after day and week after week as we do on our big farms in South Dakota. The horses weighing sixteen hundred pounds or more are better and by all odds the most satisfactory. It is the sheer weight they have to put into the collar that is the constant telling force. They can walk along and lean in the collar day after day and week after week and not feel the long, continued strain, nor lose in flesh, while the lighter horse must pull with every pound of strength he has. Each night he is tired and each morning only half rested, and he constantly loses in flesh during the long season. His period of usefulness is only a few years, while the much heavier horse with the same hard work lasts twice as long. It is his weight that counts in his favor. The light horse from mere lightness is compelled to wobble more or less from side to side in the harness, and this varies



Real plowing cannot be done with light horses

in those three verses than most men realize. Do you know "who's the whole concern's foundation—that's the man behind the plow"? Those two lines tell it all.

Honesty counts in all things and at all times, but no honesty is so sure of reward as the honesty behind the plow. The man or boy who faithfully plows straight and deep is sure to be rewarded with a bounteous crop year after year, through good seasons and bad seasons, wet seasons and dry seasons, hot seasons and cold seasons—he is always sure. The foundation of all successes in the fields lays with the man behind the plow. The amount of work done in a single day is all but nothing when compared with the quality.

Here in the West, we are a people of haste and hurry, and the great aim of most men is to do the greatest amount of work in a given time. This is a laudable aim, yet when quality of work is sacrificed for quantity, more or less of a failure is the inevitable result: and no work so surely brings its just deserts as plowing. So I say to the boy or man who goes out to plow this fall, "Remember, you are laying the foundation for the future, and your returns will be in accord with the work you do. You cannot afford to do any work but the best."

You will have a greater pride in your work, in your farm and home, in your community, if you will attempt to plow every furrow straight and deep. For he who plows shallow and crooked, and cuts and covers, will reap but a scanty crop. He will be ashamed of his crop and of his occupation, and in his innermost soul he will be ashamed of himself. Yet had he plowed straight and deep all would have been well.

the plow. While the heavier horse takes the dead-weight pull straight as a die and the plow does not vary an inch from one end of the long furrow to the other.

Where possible, every furrow should be turned in the fall, and the earlier, the better. Starting to plow early, there is no great rush to get the plowing done before the ground is frozen and one takes the time to turn every furrow well.

It is better by far to put three or four sixteen-hundred-pound horses on a sixteen or eighteen inch sulky-plow and plow deep and straight early in the fall, even though one plows a half less ground in a given time, than to put the same team on a twelve or fourteen inch gang-plow and not plow more than half deep enough.

This has been an excellent year in Dakota to see the real advantages of the honest deep plowing. The deep, straight plowing is yielding a bountiful harvest, while the shallow plowing is not paying for the labor expended. PAUL H. BROWN.

### Pasturing New Alfalfa

A KENTUCKY subscriber asks if alfalfa three inches high early in September, which was seeded in August, should be clipped or pastured during the fall. Alfalfa should not be pastured the first season no matter when seeded, and rarely clipped, when seeded so late as August. Many experiments have established this as good alfalfa gospel. B. F. W. T.

### Gang-Plowing

A READER in western Kansas, about to invest in a gang-plow, wishes to know whether a two-gang twelve-inch mold-board gang-plow runs heavier for four horses than a single twelve-inch plow does for two horses? Also, can five horses be used on a gang-plow without requiring one horse to walk on the plowed ground.

After trying both the twelve and fourteen inch double-gang plows, I have found that the latter gave better satisfaction in turning the furrows. A four-horse team that will weigh between fourteen and fifteen hundred pounds will handle it nicely. String out tandem if the horses are much lighter. We use three behind with two tandem. Anything above five horses we never use. The more horses you have abreast of each other, the closer they have to be coupled, and the center horse becomes easily heated. JOHN FAIRWEATHER.



Horses like this one will cause the plow to vary not an inch from one end of the long furrow to the other

**Come to the Fertile Northwest!**

*The Prosperity States of America*

Get a home in this Land of Plenty. Make a comfortable living—and a good profit—as thousands are, raising fruits, vegetables, grains, grasses, alfalfa, cattle (or dairying), hogs, poultry, bees.

A healthful, growing climate—land marvelously productive, in irrigated and non-irrigated sections. Free Government land in choice localities. New extensions of the Northern Pacific Railway and its allied lines are opening up rich fields to the Homeseeker. Come now, while you can buy land cheap.

Low One-way Colonist Fares effective daily September 15 to October 15, 1911. Only \$25 from St. Paul, Minneapolis, Duluth, Superior, Kansas City or Omaha to any point on Northern Pacific lines west of Springdale, Mont., through to the Coast, and many other points in the fertile Northwest. Similar reduction from Eastern Territory.

Low Round-trip Homeseekers Fares first and third Tuesdays of each month. To Montana points Homeseekers' Tickets will be sold every Tuesday in August, September and October.

Low Round-trip Summer Tourist Fares to the North Pacific Coast effective daily until Sept. 30. Tell us which state you are interested in, what kind of land you want, and what you want to do. We will send free illustrated booklets. Ask for illustrated folder "Through the Fertile Northwest."

L. J. Bricker, Gen'l Immigration Agent  
31 Broadway, ST. PAUL, MINN.

**Northern Pacific Ry**

NORTHERN PACIFIC RAILWAY  
YELLOWSTONE PARK LINE

ANYBODY CAN LAY IT.

**Rubber Roofing**

Warranted For Twenty-Five Years. FREIGHT PAID To Any Station East of Rocky Mountains, except Texas, Okla., Colo., N. D., S. D., Wyo., Mont., N. M., La., Ga., Ala., Miss. and Fla., on all orders of three rolls or more. Special Prices to these States on request.

ONE-PLY .... Weighs 35 lbs., 108 Square Feet, \$1.10 per roll.  
TWO-PLY .... Weighs 45 lbs., 108 Square Feet, \$1.30 per roll.  
THREE-PLY . Weighs 55 lbs., 108 Square Feet, \$1.50 per roll.

TERMS CASH: We save you the wholesalers' and retailers' profit. These special prices only hold good for immediate shipment.

**Indestructible by Heat, Cold, Sun or Rain.**

Write for FREE SAMPLES or order direct from this advertisement. Satisfaction guaranteed or money refunded. We refer you to Southern Illinois National Bank. CENTURY MANUFACTURING COMPANY, Dept. 573, East St. Louis, Ills.

**Ann Arbor**  
THE BALER FOR BUSINESS

"Seems as if You built Presses to Order"

Writes a farmer after reading our new Baler's Book showing over 45 styles and sizes for baling everything hayload—hops, hays and traction power. That is practically true. For 25 years we've studied and built hay presses exclusively and can supply exactly the press you need—no matter what you bale. Ask about the ANN ARBOR "20"

Operated by 3 to 6 H. P. Engine  
A farmer's press—light in weight, low in cost, simple in construction, easy to operate.

ANN ARBOR MACHINE CO., Box 403, Ann Arbor Mich.

**10 DAYS FREE TRIAL**

We ship on approval without a cent deposit, freight prepaid. DON'T PAY A CENT if you are not satisfied after using the bicycle 10 days. DO NOT BUY a bicycle or a pair of tires from anyone at any price until you receive our latest art catalog illustrating every kind of bicycle, and have learned our unheated prices and marvelous new offers.

ONE CENT is all it will cost you to write a postal and every thing will be sent you free postpaid by return mail. You will get much valuable information. Do not wait, write it now.

TIRES, Coaster-brake rear wheels, lamps, sundries at half usual prices.

**Meade Cycle Co. Dept. F-83 Chicago**

**WHEELS, FREIGHT PAID, \$8.75**

for 4 Buggy Wheels, Steel Tires. With Rubber Tires, \$18.45. Rerubbing your wheels, \$10.30. 1 manufacture wheels 3/4 to 4 in. tread. Buggy Tops, \$6.50; Shafts, \$2.10. Learn how to buy direct. Catalog free. Repair wheels \$5.95. Wagon Umbrella FREE. F. F. BOOR, Ch'go, Ill.

**Wheat or Straw?**

On some of the best wheat land the crop runs to straw. This is because there are not enough available mineral foods to balance the manure or clover. A field test on such land showed that Potash increased the grain from 20 bushels on unfertilized soil to 31 bushels where

**POTASH**

was used, and to 37 bushels where Potash and phosphate were used. Both were profitable. Supplement the humus of such land with 200 lbs. acid phosphate and 30 lbs. Muriate of Potash or 125 lbs. Kainit per acre. Potash Pays.

If your dealer does not sell Potash, write us for prices stating quantities required and ask for our free books on "Fall Fertilizers" and "Home Mixing." Study of the fertilizer question means saving and profit to you.

**GERMAN KALI WORKS, Inc.**  
BALTIMORE, Continental Building  
CHICAGO, Monadnock Block  
NEW ORLEANS, Whitney Central Bank Bldg.

RIGHT PROPORTION OF HEAD TO STRAW

CROP RUNS TO STRAW

## The Best Rubber Boots Ever Made

When a farmer spends \$4 or \$5 for a pair of rubber boots he wants his money's worth—and he's entitled to it. He wants boots that he can wear month after month.

### The Elephant Head Rubber Boots

a new brand by an old company, are the best rubber boots ever made. They are manufactured by the Woonsocket Rubber Co., whose boots for the last 45 years have led all others in popularity—and the Elephant Head is its latest and best product.

Sold everywhere. Ask for them and

Look for the **ELEPHANT HEAD** Trade-Mark—which appears also on all our shoes.

Woonsocket Rubber Co.  
Woonsocket, R. I.

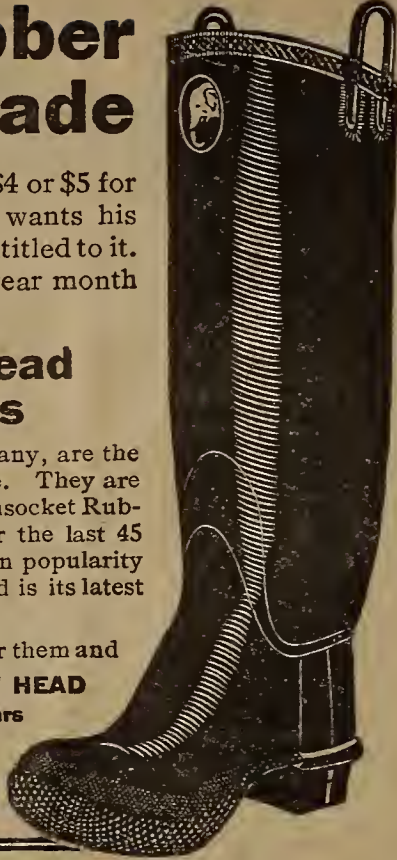

It is to your advantage to mention *Farm and Fireside* in writing to advertisers. *Farm and Fireside* folks get the very best attention.

## Farm Notes

### The Sheep-Market

RECENTLY, in addressing the Illinois State Live-Stock Board, Mr. Phil. S. Hauer, its chairman, made some very pertinent remarks, as follows: "It should be the object of every farmer to convert his grain into meat. With the population of the country growing as it does, the production of meat must be made to grow with it. The days of the range where vast numbers of cattle were reared are past, and the small farmers must be looked to to breed and rear whatever stock the land will carry. By intelligent work in this line they will make money; their farms will be improved, and they will serve their country." He goes on to advocate the cultivation and preservation of a certain proportion of permanent pasture. These wise words apply equally to sheep as to cattle.

Mr. Ogden Armour has come back from Europe firmly impressed with the idea that we have lost control of the European meat-markets, and that to Argentina they will have to look for the supplies they have for many years obtained from us.

All over the country the idea seems to prevail that for the next year or two we are threatened with a shortage of stock cattle even for home consumption, and that neither Canada nor Mexico will be able to supply our deficiency.

As regards our sheep-supply, a great variety of opinions are forthcoming. Some pessimistic souls seem to regard the sheep

business as already nearly on its last legs and only waiting for the beginning of the reciprocity treaty to get its death blow; while others of less gloomy temperament are satisfied with the outlook, and regard the check which it has lately received as having arisen from causes which are merely temporary. These latter seem to be satisfied with fourteen to eighteen cents for wool, and they are able to report a very successful lambing-season as general through the West and South.

The markets toward the end of July showed quite a revival in the demand for wethers and yearlings, and prices for fairly well-finished sheep stiffened considerably; while prime lambs stood fairly at from \$7 to \$7.50, the only trouble being that there was seldom enough of them to fill the demand. Medium to good lambs have been selling at from \$6 to \$6.50, while culls and common lots were hard to dispose of at any price.

There are no apparent reasons to expect any great changes from these conditions and prices in the near future; though the fact that both sheep and lambs from Oregon, Idaho, Montana and Washington of fairly good quality are appearing in considerable numbers is likely to prevent any great rise. From Idaho, especially, some quite prime lambs have been coming in and commanding as high as from \$7.35 to \$7.50. The supply of southern lambs, judging from reports from Louisville, seems to be nearing exhaustion, at least as regards the prime qualities.

A remarkable feature in the lamb trade, and one that should be noted by feeders, is the exact point in regard to weights which separates the "prime" from the "fair to good." Top prices seem to commence at sixty-five pounds and to run up to eighty-five; either above or below those points it is rare to find anything in the \$7 to \$7.50 class. Native and Idaho lambs between forty-five and sixty-five pounds command anywhere between \$3.50 and \$6.75. Of course, these higher prices imply that the lambs must be suitable in condition as well as in weights. For culls and common stock there has been almost no demand.

There is a matter connected with the spring-lamb trade on which, though rather late, a few words seem to be in order. Many complaints are heard as to the difficulty of inducing ewes to breed sufficiently early. The very hot spells of June and early July have made this an unusually troublesome season, but if pairing can be effected late in July and early in August, so that lambs will fall due soon after Christmas, they should be fit for the Easter markets, if kept yarded with their dams and properly fed and cared for. Such lambs are not required to run over fifty to sixty pounds.

I have always found it best to turn the ram in with all the ewes he is expected to serve, and only at night. He will make his own selections better than if the shepherd tries to use his own judgment as to which ewes are ready for service. He should be kept during the day where the cries and scent of the ewes will not disturb him, and be fed high with a liberal allowance of oats, some green food and a little good, bright timothy or clover hay; good, fresh water and salt. A handful or two of linseed-oil cake will tend to keep him in good, open condition. FARM AND FIRESIDE has already gone into the treatment of the ewes (see issues from June to December, 1910). Only remember that whatever your ewe flock may be, the ram must be a thoroughbred of one of the Down breeds.

### Maryland Farm-Land

I AM asked by a Michigan reader desiring a change of climate for information on the eastern shore of Maryland, particularly the advantages and disadvantages of climate and soil in Wicomico and Somerset Counties.

The former county is generally of a sandy nature, well suited to early truck crops and strawberries. The chief crops raised include berries, cantaloups, watermelons, cucumbers and the common truck crops. We have rapid communication to Philadelphia, Baltimore and New York by rail and ferry.

Somerset County has heavier soil and is better suited to wheat and grasses. Much of the land there is rather low and flat and needs drainage. The summers are moderated by the breeze from ocean and bay. Our sandy soil responds readily to manure and fertilizers. Crimson clover, the annual clover sown in August, thrives wonderfully well and makes fine corn crops when turned under. For general farming the upper counties on the Eastern shore are the best. Clover of any sort thrives on improved land. The tenant system is practised largely. Many of these tenants have been on the same farms for thirty years and some have handed them down to their sons, for no man is ousted so long as he farms well. Land in the upper counties has gone up to a good price, but the sandy lands here have advanced more than any. Land that I could have bought in my boyhood for less than ten dollars an acre is now up in the hundreds. Still there are cheap lands out farther from the railroad. But a man had better pay one hundred dollars an acre for ten acres near the railroad than ten dollars an acre for one hundred acres back in the forest. Commercial fertilizers are used and needed, and it pays well to use them. W. F. MASSEY.

# Overland

## A Big 30 H. P. 5-Passenger Touring Car for \$900

HERE is an automobile. The very car you have been wanting at a price that does not make you dig too deep. Just the size you want, too—big and roomy enough for the whole family. Powerful enough to do anything you want it to and more speed than you will ever care to use. It is the sort of car you expected to pay around \$1250 for.

☞ And this car is so well made. Heavy drop forgings, staunch pressed steel frame, F. & S. annular ball bearings in the transmission (the kind used on the highest priced cars in the world)—fore-door with all handles and levers inside—a magnificent body, trimmed with good leather and hair—in fact, all that you want in a car. The car is good and fine all the way through.

☞ It is fact that no other maker can produce this car to sell at this price without losing money. This year we will sell 20,000 cars. This enormous production (which is the greatest of its kind in the world) makes this low price possible.

☞ See the Overland dealer in your town about this car. Take a ride. See how silent and comfortable it runs. No careful buyer would think of making an automobile investment without first considering what we know to be the greatest value on the market today.

☞ Catalogue is ready. It is bigger, better and handsomer than ever. Write for a copy today. Ask for catalogue J-38.

### SPECIFICATIONS OF MODEL 59

Wheel base, 106 inches; body, 5-passenger fore-door touring; motor 4x4½; horsepower, 30; transmission, selective, three speed and reverse, F. & S. ball bearings; ignition, Dual; Splitdorf magneto and batteries; front axle, drop forged 1-section; rear axle, semi-floating; wheels,

artillery wood, 12x1½ inch spokes, 12 bolts each wheel; tires 32x3½ inches Q. D.; frame, pressed steel; finish, Overland blue; equipment, three oil lamps, two gas lamps and generator; tools, complete set; price, \$900.

The Willys-Overland Company, Toledo, Ohio

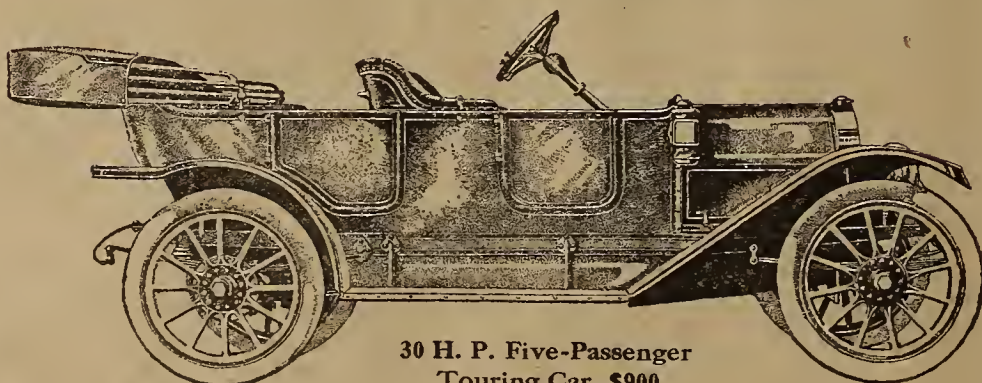

30 H. P. Five-Passenger  
Touring Car, \$900

## GARDENING

By T. GREINER

### Clean the Hen-Houses

THE advice to clean hen-houses at short intervals for the sake of keeping them sweet, and the fowls in health, would properly belong under the poultry department. For me the frequent, say at least weekly, cleaning out of all poultry-droppings is decidedly a garden operation. I want the manure. Poultry-droppings are never richer in plant-foods than when first made, unless chemical manures, especially superphosphates and muriate of potash, are added to them. Every day that they are left under the roosts they lose part of their nitrogen, the most valuable of their constituents. The sooner they are taken out and incorporated with the soil, the less is this loss. I rake the accumulations off from under the roosts, fill my wheelbarrow, and wheel the stuff to the celery-patch, spreading it evenly on both sides of each row, say eight inches, more or less, in width. The next hoeing works the manure into the soil to some extent, and I get some good of the application this season. It also makes the land richer for next season. If I have more than needed for the celery, some of it is put around tomato, pepper or egg plants, or around late cauliflowers. Prompt attention to this means not only increased safety and health for the fowls, but also better garden crops.

### Always on the String

The staked tomatoes are running up and setting fruit all along the stakes. I never go into the garden at this time without some cotton string in my pocket. The plants need frequent looking after and tying. I have already tied mine five times, and when tying I always cut or break out the laterals, leaving only the two main branches. The job of keeping the tomatoes to the stakes or poles, and looking neat and trim, requires some time and attention. Yet if it is done during our regular walks through the garden, we do not feel it. So keep them on your string and some string in your pocket.

### Late Lettuce Comes Handy

This is also the time for sowing a little lettuce-seed to give us some fine, tender heads late in fall. I usually sow the Big Boston, which is a good, fairly hardy sort. It makes good heads. I make the rows a foot apart, and sow the seed thinly. Even then it usually bears some thinning. The plants may be left several inches apart, and as they begin to head, every other plant is cut out for use. This will leave the remaining ones with room enough to form good heads. If the fall weather is favorable, these heads may be as nice and tender and sweet as we can grow them at any time of the year, in the open or under glass.

### Why Not Utilize Weeds?

Weeds grow fast at this time. They start up in places and among vines where we cannot use the cultivator or hoe any more. If left without attention, they will seed. A weed-infested patch looks unsightly anyway. In many cases the only way to do is to pull the weeds up by hand. Purslane is particularly persistent in hot weather. It is fleshy, and if left in contact with hot, moist soil, is liable to take root anew, or, at any rate, to ripen and shed a lot of seeds. I gather such seeds and throw them in heaps here and there over the patch. When I go to the garden again, I take the wheelbarrow along and load it up with these weeds, carting them to the pig-pen or hen-yard, or throwing them to the cows. Purslane and many of the tall-growing weeds that are liable, if left, to fill the soil with their seeds to plague you next and following years are good and desirable food materials for fowls, calves, pigs, cattle, etc. Pastures are often short in late summer and fall. The weeds will help out. They are better and more useful in the stomachs of live stock than standing in the fields and ripening big crops of noxious seeds.

### Pea Remnants

We have had a fairly good supply of green peas this year again, although seed was dear and scarce. Green peas were in good demand, and prices have ruled unusually high. When we have to pay six to twelve dollars a bushel for seed-peas, I can't figure out much profit in growing green peas for market, even at high prices. They are so good, however, that I want them on my table frequently and freely, no matter what the cost. The addition of young carrots, cut into little squares, makes the dish even more palatable, and we often thereby double the bulk of the mess when peas are not overplentiful. Just now I have a parcel of late-planted Alaskas. Some of the pods have been allowed to get somewhat old and hard, and past their prime for eating. I let them get fully ripe, then gather the vines and cure them, and thrash the peas out with a flail, clean and store

them in a safe place after being treated for weevils (by exposure to the fumes of bisulphid of carbon). Several years ago I thus harvested a nice lot of Thomas Laxton peas, one of the choicest of the whole tribe, and stored it in a spot accessible to mice. In the spring I had a handful of dry husks left. It was expensive feed to fatten mice with, as I discovered when I had to buy a new supply of the Laxton pea the following spring. Save all the pea remnants, is my advice. Seed will be high again, most likely.

### The Failure of Early Potatoes

I never experienced such a complete failure of early potatoes as I did this year. The excessive heat of June and part of July was too much for the vines, and they were simply burned and scorched. It is a small lot of small potatoes we are now harvesting, and the potatoes we cook for the table are hardly larger than we used to either leave on the ground when harvesting potatoes, or to feed to fowls or cattle after they were picked up. The failure seems to be a general one in this section. The later plantings, however, are coming on all right, and we will take the best care of them and possibly we may have potatoes enough to go around, after all.

### Dry Rot of Tomatoes

Mrs. U. H. D., of South Dakota, tells us that last year she was hardly able to find a ripe tomato in her patch that was not more or less affected with the rot. One cool night in the fall the vines were covered with straw quite deeply, and after that she got nice, ripe tomatoes, hardly any of them being affected with rot. I believe that the changing of weather conditions sometimes makes a difference. She also wonders whether other readers have ever tried the plan of wrapping the stems of tomato and cabbage plants loosely in a piece of paper when setting them in the field, letting the paper come well up to the leaves of the plant. This device has saved her plants from annihilation by the cutworm. Yes, it is a good device; but having no cutworms is still better. I keep them out by clean cultivation. It is also comparatively easy to poison the cutworms, where abundant, by baiting them with bran that is given a slightly greenish tinge by the addition of a little Paris green.

### Not to Forget Turnips

Ten cents' worth of seed and a big bin of nice roots! That is an easy possibility if you will now, after the last cultivation, scatter that seed (Purple Top Flat turnip) thinly over your sweet-corn patch or field of common corn. I do that regularly, picking out the bare patches or spots that are not expected to be covered with squash-vines. I aim to have the latter all over the corn-patches, but there are usually some vacant spots. It pays to have turnips growing on them; for these roots will come acceptable in late fall, long after the corn has been cut and removed. Turnips make most of their growth after the first fall frost.

### Kingbird

THE little kingbird is the best feathered guardian that the farmer can have; let him build his nest in the orchard, and he will keep a watchful eye for all winged marauders that come within half a mile of his nest. There is not much danger of hawks or crows getting poultry where he has his home. He is not musical and, at times, he may seem a little noisy, but trust him and he will not disappoint. The topmost twig of a tall tree will be his "lookout" perch and he will defend it against all comers.



There is a gracefulness of movement as he sails, with spread wings and white-banded tail, to his perch or nest while he utters his harsh cry.

The kingbird belongs to the flycatcher family. The most of its food is caught while on the wing. Noxious insects, mostly of the beetle varieties, constitute its diet. And, according to the biological survey of the United States Department of Agriculture, about ninety per cent. of this diet consists of insects; while its vegetable food consists almost entirely of wild fruits which have no economic value.

H. W. WEISGERBER.

### Persistency Kills Weeds

So long as we can go through our rows of tomatoes, cucumber and melon vines, etc., with the cultivator, preferably both ways, it is an easy job to keep the weeds down and the patch looking clean and nice. A very little effort with the hoe will do it. But when the vines get big and nearly or wholly cover the ground, weeds will still spring up and often tower high above the running vines.

Whenever I or any member of the family are gathering tomatoes or cucumbers or melons, we make it a rule to pull up every stray weed that we find in the hills. It makes a material difference in the looks of the patch and prevents seeding. Everyone is told, "Whenever you see a weed, hit it," and we strike at it even in passing.

### "Eli" The Press That Bales Two Bales a Minute

Leads them all in speed, good work, safety, convenience. Come to headquarters. We make 18 styles of Horse and Steam Power presses. Get an "Eli" and be sure of being right. Send for free catalog today.



COLLINS PLOW CO., 1110 Hampshire St., Quincy, Ill.

### GET A FARM HOME NOW

We have farms for all, both great and small. In 15 States: from New York to North Dakota; from Michigan to Missouri. For free list of fine farms ask B. F. McBurney & Co., 703 Fisher Building, Chicago, Illinois.

Money-Making Farms throughout 15 states; great variety, size and price. Stock and tools included with many to settle estates quickly. Mammoth illustrated Catalogue No. 34 free. E. A. Strout, Station 3058, Old Colony Bldg., Chicago, Ill.

### LIGHTNING HAY PRESSES

Tested for over 25 years. Made in many styles, Horse Power, Belt Power and Self-feed Attachment. Simple and Durable with Greatest Capacity. They make a Profitable Investment. We can suit you. Write for Catalog and Prices.

KANSAS CITY HAY PRESS CO. 124 Mill St., Kansas City, Mo.

## We Invite Comparison of This With Other Engines

A great many engines are advertised for pumping purposes. We have nothing to say against any of them. In fact, we urge you to write for other catalogs and get all the information possible. Study the quality of materials, the design and the records of these engines as well as our own. You need not be an engine expert to make a wise selection. Just use common sense and good judgment. We are willing to take our chances that you'll decide on the

### Fuller & Johnson Farm Pump Engine

#### The "Complete-in-Itself" Engine

You will find that the Farm Pump Engine is a complete power-plant. Everything but the gasoline comes packed in the shipping crate. Needs no belts, no pump jack, no anchor posts or specially constructed platform. Just bolt it to the pump standard and start it. It will pump

#### 400 to 1,500 Gallons Per Hour

Supplies abundance of fresh water for all farm purposes. Runs any Domestic Water Pressure System. Gives instant fire protection. The engine is as high grade as best automobile engines. It is built and guaranteed by FULLER & JOHNSON MFG. CO. (Estab. 1840) 8 Forrand St., Madison, Wis.

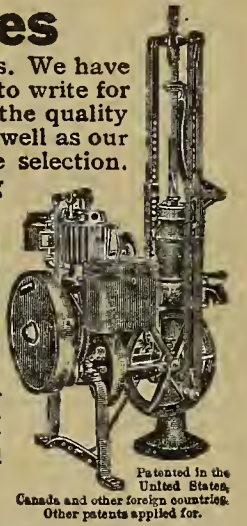

Patented in the United States, Canada and other foreign countries. Other patents applied for.

## DAIN PULL POWER SELF FEED HAY PRESS CUTS WORK IN HALF FOR MAN & TEAM

The Dain Hay Press frequently pays for itself the first year on account of the labor it saves. This wonderful pull power press discharges bales forward instead of backward. You can set the Dain at a barn door or at center of stack instead of the end. This feature alone saves one man's labor. No bulky pitman or high step-over to halt or stop horses. Dain compound leverage power supplies greatest halving pressure with least draft; permits use of short sweep—gives more frequent strokes of plunger and increased capacity—this means

bigger profits. Patented Automatic Tucker makes neat, square-end bales. Strongest hay press in the world—made entirely of steel. No wooden plunger to warp or swell. No pitman—no heavy rebound—no toggle joints to wear or work loose—the Dain Press "Makes Good" in all kinds of work. Don't think of buying a hay press before getting our big new catalog. Tells all about our full line of horse and belt power presses.

DAIN MFG. CO. 860 Vine St., Ottumwa, Ia.



## Don't Guess-Be Sure When You Sell

Keep in touch with your market by telephone. It is the surest, quickest way to get highest prices for your product. But be sure your telephone is a

### Western Electric Rural Telephone

—the kind you can always depend upon. Made by the largest and oldest telephone manufacturers in the world. Specially designed for rural service.

Mail coupon to nearest house for book giving reasons why a Western Electric Telephone is the best investment.

The Western Electric Company Furnishes Equipment for Every Electrical Need.

EVERY BELL TELEPHONE IS WESTERN ELECTRIC COMPANY

Manufacturers of the 5,000,000 "Bell" Telephones

New York	Chicago	Saint Louis	San Francisco
Buffalo	Indianapolis	Kansas City	Oakland
Philadelphia	Cincinnati	Denver	Los Angeles
Boston	Minneapolis	Dallas	Seattle
Pittsburg	St. Paul	Omaha	Salt Lake City
Atlanta	Milwaukee	Oklahoma City	Portland
Montreal	Toronto	Winnipeg	Vancouver
London	Paris	Antwerp	Berlin
Johannesburg	Sydney	Tokyo	

SAVE TIME AND FREIGHT! TELEPHONE OUR NEAREST HOUSE!

Your name and address written in this space and mailed to our nearest house will bring complete information

Booklet No. 50

Name Address

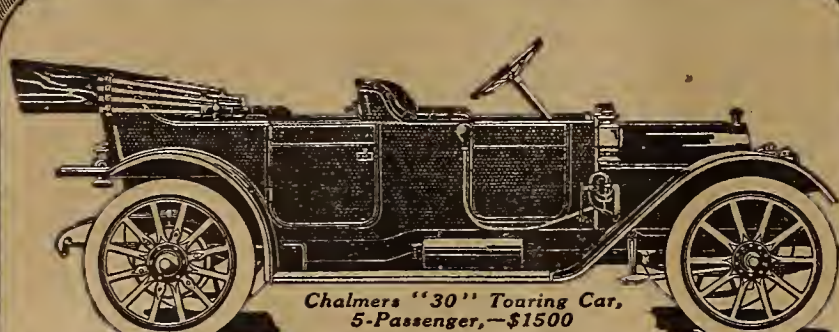

Chalmers "30" Touring Car,  
5-Passenger,—\$1500  
Including magneto, Prest-O-Lite tank,  
gas lamps, oil lamps, top, windshield,  
ventilated fore-doors, horn, tools

## "Guaranteed Sound"

**WHEN** you go to a horse market, ask the price of a horse, and a reputable dealer replies, "\$200 and guaranteed sound," you know that with this statement he guarantees the horse to have good eyes, good ears, good hoofs, sound bones, and to be free of disease.

"Guaranteed sound" really goes back of the horse as he stands before you, to the sires and dams that have preceded him and to the training and care that he has had.

Every Chalmers car is *guaranteed sound*—guaranteed in every part and particle. We not only guarantee it to be sound the day it is delivered; we guarantee a sound record behind every Chalmers car preceding it; we guarantee it to keep sound; we guarantee service.

The Chalmers car is a champion; a car with a pedigree. A car of performance—15,000 satisfied owners prove this.

It's when you get down under the hood to the heart of things that the Chalmers guarantee means most. The Chalmers motor has been the wonder of the automobile world ever since this car appeared on the market; such

remarkable power in proportion to weight, such smoothness and quietness, such reliability and economy had never been known before.

The Chalmers "30" this year is offered fully equipped, for \$1500. Last year this car sold for \$1750 equipped with magneto, gas lamps, top and windshield.

This year, refined, and improved in every possible way, with thoroughly ventilated fore-door bodies, inside control, magneto, gas lamps, Prest-O-Lite tank, and including also Chalmers mohair top and windshield—\$1500! It is the big motor car bargain for the 1912 season.

Every farmer knows that it is best in the end to buy good machinery. It is worth while to pay a little extra price in order to be certain that you get a good machine in the first place—one guaranteed by a company able to make good every promise.

We make also the Chalmers "Thirty-six"—\$1800—a car of greater size and power, including Bosch dual ignition, self-starter, Continental demountable rims and many other high-grade features.

A postal card will bring you our new catalog and the name of dealer nearest you. We shall be very glad to hear from you.



This monogram on the radiator stands for all you can ask in a motor car

Chalmers Motor Company, Detroit, Mich.

## Poultry-Raising

### Chicken Traits

**C**HICKENS are interesting—they are so much like folks; not that all folks are interesting, but chickens show human characteristics at every turn.

If I were planning to raise chickens on a large scale, the prime requisite of my farm would be a stream of water. Not because it would save labor, but for the reason that my chickens prefer water spilt on the ground to water in a dish, and I like to indulge them in every reasonable desire. They may be eating or otherwise engaged, but if I empty a pan, or if, in filling it, the water overflows, some of them always run and try to gather up the drops as if they were dying of thirst. Sometimes I pour the water around a young tree which is enclosed in wire, and one or two will strain every nerve to reach the water through the wire.

I have a "cluck" with her little flock in the nursery and have been in the habit of giving them water in a small dish with an inverted glass in the center. After a time I noticed that the dish was upset and both it and the glass were muddy, although I had taken pains to set it on a board platform. I laid it to the awkwardness of the hen until one day, when I set it down filled with fresh water, she immediately walked up and kicked it over, hastening to gather up the water as it flowed away. I refilled it and she repeated the trick. Then I took a larger dish, put a stone in it and filled it with water. This she could not kick over, and she walked off without drinking. Finding that she never drank while I was present, I one day feigned to leave and then came back just as she was raising her foot to give the dish a kick. Seeing me, she desisted and stood looking at me like a child caught in a naughty act. I had given her my opinion of her conduct and I think that my chickens understand what I say to them. Afterward she invariably put first one foot and then the other in the dish, flicking out a few drops which she tried to pick up before drinking in the usual way.

SARAH E. GIBSON.

### Gathering Road Dust

**I**N THE fall, when roads are deep in dust, I take a lot of twenty-five-pound paper flour-bags, and strings, hoe and shovel, and go to hauling road-dust for a bath for my hens in winter. One bagful is all you want to lift into the wagon, and a dozen makes a one-horse load, for it is heavy as stone. I dump in a tight barrel, and set in a dry corner, and scoop into the wallowing-bin as I need it.

C. E. DAVIS.

### Temporary Run for Chicks

**I**T is often necessary to have some place for the young chicks which will be satisfactory in furnishing range and yet is intended only for the time being. The accompanying sketch presents an idea which I have used successfully. The only objection to this is that if the clothes-pins, which are used to fasten the poultry-wire down to the sod, are of poor quality, they will break when being pushed into the ground. This may sometimes be avoided by sharpening the prongs. I have used this method with much satisfaction.

MRS. E. M. SPIES.

Note the best-laying hens and best setters, and keep them regardless of age. They pay for their keep; and by careful selection you can soon have a flock of really money-making fowls.

### Ducklings Need Free Range

**I**F, AFTER ducklings begin their growth, they are to have free range, the yards need not be very large at first. But if they are to be kept yarded the greater part of the time, then, by all means, have the yards as large as possible. An orchard properly fenced is an ideal place for either ducks or geese, old or young.

Close-mesh poultry-netting, eighteen inches wide, will be all that is necessary for ducklings. But if the yards are to be used later for the old ones, twenty-four or thirty-six inch netting should be used. We use the twenty-four-inch, with a ten-inch board at the bottom; this makes a very good fence, and one that the young ducks cannot get fastened in.

While high fences are not, as a rule, necessary to turn ducks, it is best to have

them high enough to keep other poultry out of the yards. Ducks should always be fed in their yards, even if they have free range. Feed-boards or troughs should be in the yards. Never throw feed upon the ground. When thrown upon the ground, part of the feed is wasted and the remainder is always more or less soiled.

Don't keep ducklings and goslings together. Ducks require more grain than geese. If goslings can get plenty of tender grass, they require very little other food. Ducklings like grain mixtures with some chopped green stuff added.

ANNA WADE GALLIGHER.

### The Fraud of Stimulants

**"G**ETTING many eggs these days?" The voice of the peripatetic at the door that April morning was enticingly friendly and, though I wondered what right this stranger had to know the details of my business, I answered: "Sure! What's to hinder any one from getting eggs at this time of year?"

The stranger's face fell as though he had received bad news. Then, as if taking a new grip on his resolution, he brought forth a small package, which an indifferent glance assured me was an "egg-maker" of some kind. No further explanations of the stranger's deep interest in my welfare were needed!

I promptly assured him that I never used drugs for the purpose of getting eggs.

"Why not? Don't you believe in it? You're making a mistake if you don't. They are all on to a new method of getting eggs now. They don't feed much any more; depend on stimulation. That fetches the eggs."

"Oh, of course, stimulation might bring more eggs for a time, but—"

"Brings more eggs right" along. You wouldn't believe how many are following this method nowadays. A man must have eggs when they are so high, no matter how he gets them. You are 'way behind the times if you depend on feed. Besides, this is cheaper. It's just the combination—stale bread and our stimulator—that you want. You can get the bread in the city all right, and we'll do the rest."

But I stubbornly refused to be interested, and he went away, very reluctantly, to try his wiles on my neighbor. I have been wondering ever since whether he was agent for some large bakery? Or was he just shrewd enough to advise a food which he knew was nutritious and thus a good egg-maker (being well balanced) to help carry his stimulant? Who knows, in these days, that a patent stimulant or "egg food" does not contain the blistering cantharides? If it will blister the outer skin, what of the tender mucous linings?

C. S. VALENTINE.

Someone has said, "Character is what we are, reputation is what people think we are."

Happy is the person whose reputation is *good* when it is the reflection of character within.

Have you ever thought of the fact that the farm papers you read also have character? Well, they have. And the publishers of first-class papers strive constantly to make every number reflect a high standard of character. A paper is a visitor in your home, and you would not intentionally invite it to call a second time unless you thought its association would be pleasant and profitable.

Therefore, be careful to see that the reading matter is clean, wholesome and instructive. Observe the advertising columns. They should bear the names of concerns whose honest goods but reflect the good character and reputation of honorable men behind them.

### Fastest Hay Press

**2 1/2 Tons Per Hour**  
Greater capacity is guaranteed in all Spencer Presses. The guarantee with our Alligator Press says "22 tons in 10 hours or no pay." Large feed capacity—smooth and compact bales, uniform in size. Load full weight into cars. All Spencer Presses are *biggest money makers* because they give greatest capacity at smallest operating and repair cost. Write today for Free Illustrated Catalog L. L. describing full line.

J. A. SPENCER  
335 William St., Dwight, Ill.



Make Your Own Repairs!  
Mends Harness, Shoes, Canvas, Myers' Sewing Awl makes lock-stitch like sewing machine. \$1 postpaid. Big Money for Agents. Suit has been filed in the United States Circuit Court at Cincinnati, Ohio, against W. S. Judy and Anchor Mfg. Co., at Dayton, Ohio, for the infringement of our patent No. 723,931 on Myers' Lock-Stitch Sewing Awl. Suits will also be filed against others, including sellers or users whom we believe to be infringers. The public is warned against unauthorized manufacture, use or sale of any device embodying either of our inventions. C. A. MYERS COMPANY, 6326 Lexington Ave., Chicago, Ill.

ASK YOUR DEALER TO SHOW YOU The **BLIZZARD RAPID ENSILAGE CUTTER**

It's Guaranteed

You can't afford to buy any ensilage cutter until you have examined the Blizzard which has 40 years of success behind it. Equipped with improved wind elevator, knives that can be adjusted while running. Self-feeding table. Tested by 50% greater strain than is ever called for in actual use. Fully guaranteed. Sold ready for use. Only 3 pieces. Write for "Why Silage Pays" and "The Evidence." Sent free together with latest catalog of Blizzard cutters.

Send for New Catalog

JOS. DICK MFG. COMPANY  
1444 West Tuscarawas St. Canton, Ohio

**\$29.50** Buys This Elegant **Top Buggy.**

WARRANTED FOR **Five Years.**

Retail Price \$60.00. Buggies, Surreys, Spring Wagons, Farm Wagons. We have cut out our Jobbers, our Wholesalers and our Retailers and offer YOU their profit. Write today for our **Free Catalog and Delivered Prices.**

Mutual Carriage & Harness Mfg. Co.  
Station 65-B, East St. Louis, Ill.

**PATENT SECURED OR FEE RETURNED.**  
Free Patent Book, Selling Guide and List of Buyers and Manufacturers of Inventions. Advice Free. Send sketch.

FARNHAM & SUES, Attys., 562 F. St., Washington, D. C.

**PATENTS** Send sketch or model for **FREE SEARCH.**  
Books, Advice, Searches and Big List of Inventions Wanted **FREE**

Watson E. Coleman, Patent Lawyer, Washington, D. C.

**BUY THE LOWEST COST ENGINE**

MADE. Lowest fuel cost; lowest up-keep cost; easiest on the machine. Operates, delivering steadier power than any other gasoline engine, adapting it especially for operating farm machinery, with better results and least waste of grain. Lowest fuel cost for it runs on Gasoline, Kerosene, Distillate, Gas or Alcohol and has perfect lubrication. Lowest cost because it delivers greatest available power per horse. A slow speed, high duty engine. Starts easier and quicker than any other engine, occupies less space, is less cumbersome, with less vibration, therefore adapting it for either stationary, portable or traction use. **IT IS THE POWER CONTRACTOR'S FAVORITE ENGINE.** No engine made has so wide a range of use. **YOU WILL MAKE A MISTAKE IF YOU DO NOT WRITE US FOR INFORMATION.** 1 1/2 H. P. to 5 1/2 H. P. single cylinder. 6 to 20 H. P. two cylinder. 30 to 50 H. P. four cylinder. State your requirements and get our advice.

THE TEMPLE PUMP CO., Manufacturers, 492 West 15th St., Chicago, U. S. A. This is our 59th year.





# The FARMERS' LOBBY.

## Feeding Uncle Sam's Family

By Judson C. Welliver

LET us consider now, briefly and succinctly, the case of Old Doc Wiley. Doc has been looking after Uncle Sam's whole family for a good many years, getting small pay, but enjoying satisfaction in the fact that every year fewer of his patients died.

Doc began so long ago that nobody remembers when he started in business, and has been so busy at it that he didn't even find time to get married till a few months ago. They call him "despot," "bureaucrat," "czar" and all those playful names, and they—that is, the bum food purveyors—spend vast amounts of time plotting to defeat his projects of getting good victuals fed to us.

Anyhow, Doc is to be fired, if his enemies can have their way. They think they have got a proper twist on him at last, and it did certainly look for a time as if he might go down and out. Then ninety-odd millions of folks with a prejudice against poison in their meals riz up as one man and roared.

Doc was born out in Indiana, but he doesn't say where. He tells a story when you ask his age.

"I'm like the ancient maiden," he explained, "who was summoned in court, and asked her age. She demurred, but finally said, 'I was born in the forties.'"

"B. C. or A. D.?" demanded the lawyer. She didn't answer, and I don't either."

### Wiley Always Was a Worker

BUT you can get a line on his, because he says that he earned his first quarter "about" 1858, planting corn fourteen hours in a day. He was the star corn-planter of his township, and his fame for check-rowing 'em before the check-rower had been invented had spread so far that he got a job, at fourteen years old, planting for a farmer nine miles from home.

Getting all the education he could in a country school, Doc decided that he needed a college education. He started at Hanover College, about four miles from the old home; paid fifty cents a week for his room, cooked his own meals, and in four years took all the prizes there were in the curriculum.

It is a very little thing, of course, but nobody else has taken the trouble to print it, so I shall mention right here that Doc went to the same college with a young chap named Moss. Moss grew up to be a congressman, and chairman of the Committee on Expenditures in the Department of Agriculture. That committee is now investigating the case against Wiley and the alleged conspiracy to drive him out of the government service.

Turned out of Hanover with a roll of sheepskins and \$1.25, Doc wondered whether he could earn a living. He didn't wonder long. While he had a great leaning toward chemistry, he was so good in languages that Butler College, Indianapolis, offered him the instructorship in Greek and Latin, and he accepted.

He took a medical course at nights and soon wanted to practice medicine. But the college couldn't let him off; it offered him the chair of chemistry, and he agreed to take it if they'd wait till he could go to Harvard for a year's special work. They waited.

### The Bureau Grew Rapidly

THAT was the beginning of this chemistry specialty that has made it almost impossible for us to poison ourselves with the breakfast-food or the salad-oil. Twenty-nine years ago he was made chief chemist of the Department of Agriculture. There were five people in the bureau then, and there are five hundred now; but the job was a snap for the five, for there was nothing much to do.

Doc began looking about for something to keep him busy. There was no pure-food law, and nobody realized that one was needed. He started a movement to get one, and that involved making the people understand why it was needed. At last, after fighting for twenty-two years, he actually got a pure-food act passed by Congress. I say "he" got it passed, because I saw it happen, and know that it wouldn't have been secured yet if it hadn't been for Wiley. The powerful interests that didn't want interference were on the job day and night in Washington to prevent "political interference with business," and they beat him time and again. But he got what he wanted, in the main, in the pure-food law. And with it he got what he loves, a new fight.

For the law had no more than passed when the opposition began a campaign to prevent its effective enforcement. Wiley was now the chief executive officer of that law. To a man who wanted to use just a little green

paint on the school-girls' candy, or a bit of formaldehyde to embalm bad tomatoes in the ketchup, or yearned to "season to taste" with benzoate of soda in the preserves, Doc Wiley suddenly looked a lot bigger than the Washington monument. He wouldn't have it. He thought the law meant what it said, and at any rate he made it mean what HE said, which was still better.

Unable to circumvent him on either law or chemistry, his enemies appealed higher. They said he was a crank.

So there was created a sort of appellate court of chemistry, composed of three members: Wiley, chairman; another chemist, and a lawyer. Matters could be appealed from Wiley to this appellate court, and although the other two members were frankly hostile to Wiley's ideals in many cases, still he won so many of his contentions that it presently became necessary to create yet another appellate court.

That was where the Remsen board of appeals in chemistry came in. Wiley had decided against using benzoate of soda in food. He maintained that it was a dangerous preservative because it disguised the evidences of decay, and made it possible to fix up bad vegetables, fruits, etc., in such form that they would be eaten by innocent purchasers misled by glittering labels. Benzoate was mighty important to a lot of the food manufacturers, and they finally figured out the Remsen board of appeals, in order to get a rehearing on the question. There was nothing in the pure-food act to justify creating such a board; but it was created just the same, and told to experiment with benzoate of soda and see whether it was so bad as Wiley claimed.

To this board were appointed five eminent chemists: Dr. Ira Remsen of Johns Hopkins University; Dr. Russell Chittenden of Yale; Dr. J. H. Long of Northwestern University; Dr. A. E. Taylor of Pennsylvania University; Dr. Theobald Smith of Harvard.

### Changed the Experiments to Prove a Point

NOTE now how cleverly the trick was turned. Wiley had experimented by feeding to young men the ordinary food products in which benzoate is used. He found the results bad. This was the work of his celebrated "poison squads." When the matter was sent to the Remsen board, it had a very different assignment. It experimented with small doses of benzoate, mixed, not with half-decayed vegetables, but with perfectly good foods. The result was a verdict that benzoate was harmless.

It cost over \$100,000 for the series of experiments, the publications, the salaries, etc., which led up to that decision. Note the figure. It will be significant later in this story. **OVER \$100,000 WAS SPENT IN THE EXPERIMENTS THAT BACKED UP A VERDICT WHICH SERIOUSLY WEAKENED THE FOOD LAW AT A HIGHLY IMPORTANT POINT.**

And there was absolutely no law to justify it. An assistant to the attorney-general issued an opinion so holding. But then they got another opinion from the lawyer-member of that first board of appeals I have already described, holding that the Remsen board was legal enough; and the attorney-general decided to stand on this decision of the lawyer-food expert, rather than on that of his own assistant.

This much for the methods of circumventing the law when it was desired to WEAKEN the food law and give the dopesters their way. Now we will turn to the other side and note the technical compliance that was demanded when Old Doc Wiley wanted a measly \$1,600 to hire experts on HIS side of the poisoning cases:

In prosecutions under the food law expert chemistry testimony is frequently wanted. Wiley had used Dr. H. H. Rusby of New York as an expert. Rusby, an eminent man in his profession, came high. There was no provision in the law which covered the hiring of this kind of expert witnesses; yet the government couldn't win its cases without them. Rusby cost forty dollars a day when he appeared in court as a witness, and twenty dollars a day when he worked in his laboratory. Wiley MUST have him, but the law didn't provide a way to do it. So after conference with people in his bureau it was agreed that Doctor Rusby should be put on the salary roll of the bureau at \$1,600 a year, with the understand-

ing that he would do, at the regular rates charged in his profession, \$1,600 worth of expert service annually. He was not to be expected to work every day, but he was to be subject to call for expert work up to the amount of that salary during the year.

There is no disagreement about these facts. There is no charge that Rusby was paid more for expert service than it was worth, or more than it would have cost if it had been secured in some other market. Nobody has charged that Wiley "grafted," or even that there was any suggestion of favoritism about it.

But it was not strictly in conformity to the law. The lawmakers had not thought about providing for such cases, and, the law being iron-clad and without loopholes, Wiley's enemies discovered that Old Doc was a lawbreaker. Awful, horrific thought! Wiley, the life-long persecutor of lawbreakers, the foe of graft, caught breaking the law and getting money out of the treasury in a wickedly irregular way!

### Did Wiley Resign?

IT WAS just what the anti-Wiley plotters had long wanted. They would have been glad to dismiss him, only that the people would never stand for such a thing. But here was the chance. They would tell Doc he had been caught grafting; tell him they were sorry for him; he had been a well-intentioned person, but not quite smooth enough. Didn't he want to resign, very quietly, avoid all fuss, and get out without being disgraced?

There was the plan. It was beautifully framed up. The Board of Personnel at the Agricultural Department investigated the case, and found that it was a heinous offense. Rusby should be fired, Wiley allowed to resign. The attorney-general—same attorney-general who had been able to switch opinions in time to prove that the Remsen board was legal—the attorney-general sustained the Personnel Board and opined moreover that nothing less than "condign punishment" would be fit for so bad a person as Wiley.

In this form the affair went up to President Taft for final action. He was still ruminating about it, and the public had not dreamed that such a thing was going on, when suddenly the story leaked. It broke into print in all its details one morning.

The reporters asked Doc about it, but he sat tight and said never a word. "Resign?" he snorted finally, when he was a-wearied of the foolish questions, "Resign? I should say not; I'm going to stay right here and see what will happen to me."

The story, bit by bit, got into circulation in all its finest details and shadings. Somebody was mean enough to compare the legal opinions which had commended Wiley for "condign punishment" and held the Remsen board perfectly legal, and the thing began to take on a comedy aspect.

Then, through the insistence of the newspaper men and the energy of the congressional probers—for Moss and his committee had got at work promptly investigating the affair—the details of Wiley's long fight against continued hostility and bitter opposition, for the effective enforcement of the pure-food law began to come out. Instead of looking like a criminal condemned to the condign, Doc loomed before the public all at once as a martyr with a triple-plated halo. He always has needed a halo, for he's painfully bald. He looked beautiful in the one that Public Opinion promptly adjusted to him.

### "Pure Food For All"—is the People's Plea

THE anti-Wiley party has been on the defensive ever since. Ingenious folks have dug up the fact that the very method by which Wiley circumvented a too rigid law, is employed every day, in effect, in various departments of the government, to accomplish practically the same ends, and nobody ever before found fault.

Democrats and anti-Taft Republicans in Washington have been sitting up o' nights to pray that Taft will "fire" Wiley. They figure that it would be the finest politics, for them, that the administration ever perpetrated. Looking at Doc Wiley's desk one of these mornings, piled six inches deep with telegrams and letters of endorsement, confidence and reassurance, one is compelled to believe they are right. The country is for Old Doc Wiley. It has been taking his prescriptions for a long time, and is pretty sure he's right. He may be fired, but if he is, it will only mean that he will come back after March 4, 1913.

# The Little Trust

## How a Young Man's Dreams Were Realized

By Vincent Oswald



"DO hope she arrives soon!" remarked Mrs. Carroll anxiously, glancing askance at the little clock on the mantelpiece.

"Who?" asked her son carelessly, as he rose with a yawn from the chair in which he had been reading the morning paper.

"The new girl, Bruce, the washerwoman Mrs. Dixon recommended to me. She spoke so highly of this person that I got the impression the girl was perfection itself; but it doesn't look much like it when she's late on her very first day in a new place."

"Well, I guess it's about time for me to get under way if I want to be down-town anywhere near nine o'clock," said Bruce, opening the wardrobe and reaching for his coat and hat. "But, I say, Mother, I wouldn't be hard on the girl, the cars may have been blocked. Besides," he added, as a shadow flitted across his thoughtful, serious face, "it's almighty tough on a woman to have to go out daily to work like that. You and I know only too well what *we've* gone through to get to the modest, split-even decency of our present condition." And he glanced about the plain little apartment which only her busy, loving hands kept comfortable and homely instead of bare and poor.

"Never fear, Bruce! I think you know very well there's no danger of *my* being hard on a girl that works. Indeed, I'm merely disappointed, that's all."

"Yes, Mother," he continued, as he pulled on his coat, "I think you and I put up about as good a front as anyone could on an income as small as my salary represents; and the way *we* have to economize—not to say struggle—makes me constantly wonder how in the world these people get along who make only twelve or fifteen dollars a week for the support of a home and family."

"My dear Bruce, the majority don't make *that!* Take this girl, for instance: she gets a dollar and a half for a day's work—washing, ironing or house-cleaning. That's nine dollars a week."

"Heavens!" he murmured. "I don't know how they maintain homes."

"Yet, in our case, Bruce, I grudge her even that. The washing and ironing are the only things I don't do myself; and I just hate to see *anything* spent for help."

"Now, now! I draw the line right there, Mother!" he exclaimed decisively. "I positively won't stand for what you're intimating. I've got you at last into a state of fairly comfortable health, and I'm going to take no chances."

She rose from her chair, too, and laid a hand tenderly on his shoulder.

"Bruce," she said with quivering lip, "you're a good boy, God bless you! You've been such a son as any mother might well be proud of; but—but I don't want to be a burden to you, Bruce. You're thirty years of age, Bruce, and—and you might be supporting a wife instead of maintaining a home for a half-invalid old mother."

He seized her face between his hands and gazed into the swimming eyes.

"Look here," he said challengingly; "why shouldn't I do *both*? I've never seen anyone who made me think of marriage; but if I ever do, she'll also inspire me to work out the problem—*good* wives always do; but don't you—"

He was interrupted by a sudden, nervous ring of the door-bell.

He stepped to the door and held it open. Then he stared blankly while the figure on the threshold nodded her thanks and, entering, greeted Mrs. Carroll. She looked worried.

"I do hope I haven't inconvenienced you," said the girl in a clear, sweet voice. "I'm so sorry, but everything seemed against me this morning. I was a little late getting away from home on account of a sudden sick spell of my invalid brother; and then the cars were blocked. Of course, I shall stay and make up the time."

"There, there, don't fret about it," replied Mrs. Carroll kindly. "There's no harm done, Miss uh—"

"Drake, Margaret Drake is my name."

"Well, Margaret, the stationary tubs are in the kitchen, and you'll find the wash in a basket beside them."

The girl bowed and withdrew.

Meanwhile, Bruce had been regarding her with an ill-concealed amazement which, fortunately, she did not observe.

No wonder he contemplated her in astonishment.

At mention of the word washerwoman, one inevitably pictures a person of mature years and not very comely. But she was young and very attractive-looking, not over twenty-four, tall, and her form, full of the strength, energy and grace of youth, was slim and flawless; her face was a delight to look upon, so honest was it, so open, so full of earnest cheeriness, so strong and true, yet so kind and gentle, with a mouth that puzzled one to decide whether sweetness or bravery predominated in the little halo that seemed to hover about the half-sad lips; the speech was correct and fluent, if not cultivated, and the whole expression was one of intelligence, character and superiority.

Bruce bade his mother farewell, and left the house full of a nameless wonderment. It was the first time he had ever seen a woman who interested him.

The days were shortening rapidly, and when he reached home that evening, darkness had already fallen. He met her leaving the house.

He lifted his hat courteously, and she bowed, smiling. "Some of the streets around here are not altogether pleasant just now," he said kindly. "If you will permit me, Miss Drake, I'll see you to your car."

She flashed him a look of grateful assent, but could not refrain from adding deprecatingly:

"You make me forget the washerwoman in the lady." "Sometimes," he retorted, in his deliberate, sincere way, "the two are synonymous."

"You have a very sweet mother," she said irrelevantly.

"Yes, God bless her! She's all I have, and I must take good care of her. But she's had a great deal of sickness and trouble, and will never thrive here in the city. For a long time, however, I've been cherishing the hope of changing things radically. She doesn't know it, but I've been secretly trying to arrange my affairs so that we can live in the country."

"Oh, I love the country!" the girl remarked. "My poor brother and I were born and raised in it, and I think we've never quite got over the necessity for leaving it."

"Then you actually *know* something about real country life?" he asked eagerly.

"Yes, indeed; but not so much as Dick. I think there's nothing he does *not* know about it—he loves it so. Neither of us care for city life."

"See here!" he exclaimed earnestly. "You can prob-

like you," he went on, in his open, frank way, "and, if you don't mind, I'll tell you a little about ourselves. Molly has told me you want to get some information from me about country life; so, since we're going to have some intimate chats, it may be pleasant for you to know a little about us."

Then he told Bruce how they had been born and bred on a large Connecticut farm owned by their father who, at his death, left the property to his wife. Dick was only eighteen at that time; and the mother—perhaps partly through fear that they would not be able to manage the place successfully, but undoubtedly largely because her susceptibilities had been touched—married a neighboring farmer. It soon became evident to the children that the man was a scheming self-seeker and not at all competent, so the burden of operation fell upon Dick's shoulders. Four years after the marriage, Dick fell from a hay-wagon and injured his back so badly that he could not walk. A year after that the foster-parent accepted a flattering offer for the property, and their country life came to a sudden end.

"Then," concluded Dick, "when I was no longer able to make money for him, this cold-blooded wretch practically turned me out, helpless though I was, and my poor mother had fallen so completely under his influence that she made little or no attempt to prevent the outrage. But dear old Molly stuck bravely by me. That was five years ago; and she's had a hard time of it, but she is always so cheerful and never complains. She's done anything and everything—from tending children to scrubbing floors—to keep the wolf from our door during my helplessness."

All that evening the men talked earnestly, and when they parted, each had won a warm place in the other's regard.

After that Bruce went to see Dick often and they became very good friends.

One morning, after the girl had reached the little apartment, Mrs. Carroll was bewailing the price of foodstuffs.

"It's simply frightful how things have gone up!" she cried. "Meat's up, vegetables are up, flour's up, clothing's up—oh, *everything's* up, up, up, and I don't know where it's all going to end."

Bruce winked at the girl, and exclaimed laughingly, "Be patient, Mother, and we'll get the better of the robbers. I have a wonderful plan for reducing the price of foodstuffs. As soon as I can work it out successfully, I'll tell you all about it."

"I've come to the conclusion that your plan is entirely feasible," Margaret said to him as they rode toward her home that evening.

"But, you know, I've told you and Dick that my 'capital' is limited to five hundred dollars."

"It's enough," she said positively. "I've seen dozens of little, run-down farms, with small but comfortable houses, advertised for sale at all sorts of prices ranging from a thousand to two thousand dollars, and purchasable with from three to five hundred dollars cash down. The winter's coming to an end, now, and spring will soon be here. If you would begin your search immediately, you might succeed in finding a suitable place before spring. Then, too, buying it in an 'off season' like this you'll get it cheaper. Why not send Dick out to search for the property?" she suggested. "He's well enough, now, to get about slowly. He has nothing to do, and the occupation would be a delight and a blessing to him. Dick's eye for a farm is as true as the scent of a hound for a fox, and I know he will soon discover some wonderful bargain for you."

"But," he said hesitatingly, a shade of doubt hovering about his face, "suppose that I, too, should fail after I had moved my mother and my home to the country and given up my position? But I *hate* that position!" he went on vehemently. "I can never be happy in the work—paltering around an office, adding figures and checking bills! and there is very little chance for advancement, and the work is so confining."

"Your feeling is a *true* instinct," she said with conviction, as she glanced approvingly at his stalwart form. "You were made for *man's* work, and you will never be happy till you get into it. But, you know, if you wanted to feel your way carefully, instead of leaping into it all at once, you could put Dick on the place for the first year, and let him run the farm while your mother kept the house. Dick can't do plowing and heavy work yet, but it wouldn't cost much to have the plowing and harrowing done for him, and he could take care of all the planting and cultivating. Then, you could go to it every Saturday afternoon and stay till Monday morning. If you kept in touch with things that way, Dick could, in a year, teach you so much that you'd have none of this hesitancy in taking the step the second year. It would mean a new lease of life to your mother and—*and* Dick."

He looked at her wonderingly, for he knew what the separation would mean to her.

"I believe you'd make any sacrifice for that brother of yours," he said slowly.

"And why not?" she questioned. "From childhood he has shielded and cared for me. I owe him *everything*."

"But you?"

"It will be enough for me to know that Dick is well and happy."

"Humph!" he muttered, gazing askance at her down-cast eyes and flushed face.

"But," she went on, "I think you ought to *keep* that money of yours in the saving fund, exactly as it is now."

[CONCLUDED ON PAGE 20]



... he stared blankly while the figure on the threshold nodded her thanks"

ably help me—you and he—help me to solve some of the problems in my great, secret plan. May I hope that you will?"

"If our experience can be made of use to anyone," she replied, "I'm quite sure it will be a real pleasure to both of us. As for Dick, to talk country projects over with you will be a bright spot in his poor, lonely life."

"I've been trying hard to find someone who really knew practical country life from A to Z—all the tricks of the farm's trade—and now it seems that the opportunity to get the information I want has at last come my way. But here's your car! Good-night! And thank you *ever* so much for your promised help!"

That was the beginning; but the end was still far off.

When he went to see her brother, he found a young fellow of twenty-eight who had once been all that his sister now was, intelligent and capable; with the same open, brave face; the same charm of personality; the same energy of mind and purpose; but a bad back that compelled him to hobble weakly about with the aid of a cane.

"It's better now," he said brightly to Bruce. "I spent two years unable to get out of bed; but the doctor says that, with care, I'll very soon be able to do all sorts of light work involving no physical effort. If it hadn't been for that noble sister of mine, I never should have pulled through, but she gave up everything and devoted herself to me. Why, she jumped right into the breach and made literally a *slave* of herself to secure me a living."

"She is one girl in a thousand," said Bruce, with considerable emphasis.

"You don't know how I appreciate her goodness," exclaimed Dick. "You don't know all. See here, I



## "As Little Children"

By Rev. Joseph M. Long

**I** WAS setting out some plants the other day, with the aid of my little boy, who is my inseparable companion in gardening, when a thunder-shower began to threaten. Being anxious to get the last plant in the ground before the rain struck, I kept on, finishing just as the big drops began to patter. The little fellow is usually afraid of thunder, but when I told him that the lightning generally went into the ground harmlessly, or hit some tree or other object, and rarely hit a person, he seemed perfectly reassured and after that paid no attention even to several crackling peals that startled me. He seemed to think that, as papa was a grown-up man and knew all about it, there really wasn't much danger and he wouldn't be afraid. The incident was in my mind the rest of the day as a lesson of faith in the Heavenly Father, who has said so many times in the course of the Divine Revelation, "Fear not," "Be not afraid."

At another time, watching the children at play, I noticed that the youngest kept climbing up on the roof of a little out-building, and at his big brother's command would fling himself boldly off into the latter's arms, although it was some little distance. It would be impossible for us adults to throw ourselves down with the same confidence and abandon, however strong the person who was to break our fall; we would instinctively step off carefully and jump down, feet foremost, in order to alight on them in case the other should not catch us properly. We have learned caution in trusting ourselves to anything human and material, but how beautiful the lesson of confidence in the Power that is more than human!

I offered my little girl at the table some dessert, on one occasion, but she replied, "I don't want any, papa, because I can't have any." Her mother had put her "on diet," it seemed. But the answer made me ponder a good deal. Someone has said, "The essence of philosophy is, when you can't have what you want, not to want it." Isn't it an important principle in morality, also? Hankering after things they ought not to have, forbidden pleasures or other objects of desire, has probably led more men into sin than any other one cause.

More and more I appreciate the wisdom of our Lord in placing a little child in the midst of His disciples as an example of the docility, the faith, the natural, unconscious humility that He would teach His followers. It is said that Ralph Waldo Emerson would stop by the wayside for hours to converse with an artless little

child, when he would shun as a bore some would-be philosopher who had sought him out. How many things we parents may learn from our little ones, if we keep our ears and eyes open!

To be sure, we are not to be children, but to be "as little children"—not to be childish, but childlike. We need to "put away childish things"—lack of purpose, changeableness, giving our time and strength to objects unworthy of our maturer powers. But we should retain the qualities which are beautiful in every character and are prominent in a child who is natural and unsophisticated. He is conscious of his many limitations, his lack of knowledge and strength, his inferiority to his parents. He is humble without knowing what humility is, which makes it all the more beautiful. The loyal faith of the average small boy in his father is something touching to see. To his child the father stands in the place of God Himself. This should teach us faith in the wisdom and greatness of the one Father who alone fulfils the idea of fatherhood. It should also, by the way, make us more careful of our words and acts. I know a man at whose home a little nephew was spending the afternoon. He was interested in watching his uncle working on his boat. Afterward the little fellow said to the wife, "Auntie, the Lord was here this afternoon." "Why, what do you mean, child?" "Cause uncle spoke to Him when the hammer pounded his finger!" When the man told the incident to some friends, they laughed, but he added, seriously, "I tell you I'm going to be careful what I say before that boy, I don't want him to learn profanity from me." Probably more than one father has felt ashamed, when he has heard his child's comment on some careless remark.

These thoughts call to my mind a time long ago when another boy and myself were climbing about in a tree. I got down again safely, but he got into a place where he could not go forward or back, and yet felt afraid to drop, the ground looked so far away. I stood underneath and called to him to drop, and I would catch him and break his fall; but he would not trust me, and told me to call his mother. When she came, she stood underneath the branch and simply said, "Now drop, Jamie," and he let himself fall into her arms, reaching the ground without harm. "Underneath are the Everlasting Arms," are the beautiful words of Deuteronomy, and as we are touched by the perfect, unquestioning faith of our children in us, shall we not learn a deeper trust in our Father who is in heaven?

## Resting the Engine

By Orin Edson Crooker

**F**ARMER, are you careful to rest the engine one day in seven? Perhaps you haven't yet arrived at the point where you do most of the farm work with gasoline power, and consequently you think this question isn't meant for you. But it is! Every farmer is a liberal user of power of some kind. His horses—and mules, if he has any—together with himself and the hired man, constitute the "engine" which does the farm work, whether it be plowing, harrowing, cultivating, harvesting or something else.

Now, do you give the engine a rest once in a while? Or are you going on the principle that you have discovered a form of perpetual motion, and that you and the hired hands can go on forever and a day at the same old grind without showing the effects of it? There is many a man on the farm who is good to his team and who wouldn't think of working it on Sunday for anything, but at the same time he is pushing his own engine to the limit of its powers. Sunday finds him doing a lot of odd chores about the farm that he says he's too busy to do at any other time. He never goes to church—never takes a day off—he just plods along week in and week out, including Sundays, as though he had solved the problem of perpetual motion and never expected to stop going until the family find it necessary to send for the undertaker.

Of course, there isn't much use in arguing with a man about whether he's got time to go to church—especially when a lot of things are pressing him hard and

he feels he's got to attend to them. But we may be permitted to give out the observation that taking the countryside over, the best-kept places—the farms which show on the face of things that the odds and ends have been looked after and that things are kept right up to the handle—are those whose occupants rest their engines once a week by observing the Sabbath. A man who lets his mind get into new channels on Sunday and who gives his muscles a rest into the bargain will feel so much more like working on Monday morning that he will get a sight more work out of the way during the week than some other fellows who never would know it was Sunday unless they heard the church-bells ring or saw folks pass on their way to meeting.

\* \* \*

Being all fashioned of the selfsame dust,  
Let us be merciful as well as just.

—Henry W. Longfellow.

It's always better to make the mistake  
of doing too much than of doing too little.

—O. E. Crooker.

Attempt the end, and never stand in doubt;  
Nothing's so hard but search will find it  
out.

—Richard Lovelace.

The world is a looking-glass,  
Wherein ourselves are shown,  
Kindness for kindness, cheer for cheer,  
Coldness for gloom, repulse for fear—  
To every soul its own.

We cannot change the world a whit,  
Only ourselves which look in it.

—Susan Coolidge.

# La Follette's Autobiography

**U**NITED STATES Senator La Follette of Wisconsin has written his autobiography for serial publication in **THE AMERICAN MAGAZINE**. The September number, just out, contains an interesting preliminary announcement. The October number will contain the first chapter. You will not only want to read every word of it, but we are sure that you will tell your neighbors and friends about it, so that they may not miss a single chapter.

**"BOB" LA FOLLETTE**, as he is affectionately called, is one of the greatest fighting liberals in the world. He is the leading Insurgent in the United States to-day, and Insurgency is the most important movement since the Civil War. You are therefore going to hear the inside story of a great movement as told by the chief figure in it.

But you are going to hear more than that. You are going to hear the personal and intensely human story of "Bob" La Follette—the Wisconsin farmer's boy who became the District Attorney of his county at 25, Congressman at 30, and then Governor and Senator. For 30 years he has been in public life, and always he has fought tenaciously for what he thought was right. He has never known what it is to be an easy-going politician. He is a fighter—a worker—always. This very summer, at the age of 56, in hot Washington, he frequently worked clear through the night until breakfast-time—and then on through the day and evening. Get clearly the idea of a tremendously vital and active man.

For long periods, both in Washington and Wisconsin, he fought almost single-handed. He was the great lone fighter. He made his native state (Wisconsin) just about the best governed and most honestly governed state in the Union—but what a fight it was! All through these long, uncompromising battles he had a world of adventures and met a host of great men—all the important men of our time, including Tom Reed, Carlisle, Blaine, Garfield, Allison, Spooner, Cleveland, Bryan, Roosevelt, Taft and others. These adventures he will report, and all these men he will characterize with naked candor.

No reader of **FARM AND FIRESIDE** will care to miss the greatest true story told in years—"Bob" La Follette's Autobiography.

We will send **THE AMERICAN MAGAZINE** to any **FARM AND FIRESIDE** reader for a year for \$1.50, and we will send **WOMAN'S HOME COMPANION** for a year for \$1.50. We will send both **THE AMERICAN MAGAZINE** and **WOMAN'S HOME COMPANION**, each for a whole year, for the special price of \$2.20.

Both **THE AMERICAN MAGAZINE** and **WOMAN'S HOME COMPANION** are published by the publishers of **FARM AND FIRESIDE**.

## THE AMERICAN MAGAZINE

The Crowell Publishing Company

381 Fourth Avenue, New York City

# Three Simple Crocheted Designs

By Charlotte F. Boldtmann



**T**HE three designs illustrated on this page are sure to interest the woman who likes to crochet. The first is a crocheted square. These squares will make a handsome bedspread if used alternately with heavy squares of cream-color linen.

If the bedspread is made in this way, it should be edged with a border like the border of the block.

Use a hard, twisted crochet-cotton and a steel needle sufficiently large to carry the cotton. The cotton may be No. 10, or even coarser in size, as one wishes.

The medallions are made first. Ch 10 and join in a ring, 24 s. c. in the ring. Join.

Second Round—Ch 3, 6 d. c. in first stitch of preceding round, drop the loop from the needle, pass the latter in the top of the first d. c. made and draw the loop through, thus forming the first puff of the round. \*Ch 3, skip 2 stitches of preceding round, make a puff in the third, and repeat from \* to the end, when there will be 8 puffs in the round. After the last puff ch 3 and join to the first puff.

Third Round—Slip stitch to the second ch after the first puff of preceding round. In it work 2 s. c., then 1 s. c. in the third ch. \*Ch 5, 2 s. c. in second stitch of next 3 ch, 1 s. c. in third ch, and repeat from \* to the end, making 5 ch at the end and joining it with a slip stitch to the first stitch of the round.

Fourth Round—Slip stitch to first ch loop, ch 2, \*3 d. c. in loop, ch 5 and catch in last d. c. made for a picot, 3 d. c. in same loop, ch 8, catch back in the third ch made for a picot, ch 2, 2 d. c., picot, 2 d. c., picot, 2 d. c., picot, 2 d. c. all in the next ch loop; ch 8 and catch in the third ch made for a picot, ch 2, and repeat from \* all around. At the end join and fasten off. The large scallops form the corners of the square medallion.

Make four medallions in all, joining them on the 3 side picots, to form a square. Now work all around the square, as follows:

In one of the outer corner scallops work 1 d. c. in the center picot, ch 5, 1 d. c. in same picot, ch 8, 1 s. c. in first picot along the side of the same medallion, ch 3, 1 s. c. in next picot, ch 8, 1 d. c. in center picot of corner, 1 d. c. in center picot of corner of next medallion, ch 8, 1 s. c. in first picot along the side, ch 3, 1 s. c. in next picot, ch 3, 1 s. c. in next picot, ch 8, and repeat from beginning to the end of the round. Join.

Second Round—Slip stitch to the center stitch of the corner, ch 3 (to count as 1 d. c.), 2 d. c. in center stitch of corner, ch 3, 3 more d. c. in same stitch as before, ch 2, in the first 3 ch of next loop work 1 d. c. each, ch 2, 2 d. c. worked on the last 2 ch of same loop and 1 d. c. in the s. c., \*ch 2, 2 d. c. worked in ch before next s. c., 1 d. c. in s. c., repeat from \*, ch 2, 3 d. c. in center of next ch, ch 2, 3 d. c. over center picot. Work the second half of this side as the first half was worked, and

work each of the other sides in the same way. Ch 2 after the last cluster and join to starting ch.

Third Round—Ch 2 over each space of preceding round, and over each cluster work 1 d. c. in first d. c., ch 1, 1 d. c. in last d. c. At the corners increase by putting an extra d. c. in the corner space and 2 ch at each side of it.

Fourth Round—Work like the second round, making a cluster over each cluster of the second round, and working 2 clusters in each corner stitch.

Fifth Round—Put 1 d. c. in the corner space, ch 5, another d. c. in same space. Ch 2, skip to next space and in it put 2 d. c. separated by 3 ch.

Ch 2 and in the next space put 2 d. c. separated by 5 ch, and alternate in this way around the square. Each side should have 11 loops and a large loop should always be made in the corner. To bring this out properly the loops must be spaced along the sides and occasionally worked on a d. c. instead of in a space.

Sixth Round—In each 5-ch loop work 1 d. c., ch 3 and catch for a picot, 2 d. c., picot, 2 d. c., picot, 1 d. c., in each 3-ch loop work 1 s. c., ch 3, 1 s. c. Between the loops work 2 ch. At the end of the round join and fasten off.

The centerpiece, which is crocheted in tiny rings, makes a pretty addition to a table and is easy to work. A hard, twisted, No. 40 or coarser cotton is the thing to use, with a needle no larger than the cotton requires. Make a thick ring of the cotton over the end of a pencil and over this ring work 36 d. c. Join.

Second Round—1 s. c. in first stitch of preceding round, \*ch 5, skip 2 stitches of preceding round, 1 s. c. in next, and repeat

from \* to the end. Join and fasten off. There will be 12 loops in the round. All the rings of the pattern are made in this way. Around this first or center ring 6 other rings are made, each one joined to 2 loops of the center ring. For the placing and joining of the other rings of the pattern the illustration may be followed. When the star of rings has been completed, the border is worked all around, as follows: Work a loop over each loop all around the edges of the star, and between the rings ch 7.

Second Round of Border—Work in loops as before, and on each 7 ch, excepting those separating the points of the star, work 2 loops. On the 7 ch which separate the points of the star work 3 ch, 1 d. c. in center ch, 3 ch. Make 4 rounds more in this way, always skipping the space at each side of the d. c. which separates the points of the star, and working 1 d. c. in 1 d. c. Then make 1 round with 7 ch in each loop, and 1 round with 9 ch. On this round make 1 s. c. on the d. c. between the points.

Another crocheted centerpiece is made of wheels which are joined together, and a pretty set may be made by using the center wheel alone for the doilies. For this set use a No. 30 or 40 crochet-cotton, with a needle only large enough to carry the thread.

For the center wheel make a thick ring of the cotton over a finger-tip, and over this ring work 42 d. c. Join. Hereafter it will not be necessary to join the rounds.

Second Round—Ch 3, 1 d. c. in third stitch of first round. Repeat all around, when there will be 14 spaces in the round.

Third Round—3 d. c. in each space, 2

ch between the spaces. Work the fourth round in the same way, but put 3 ch between the spaces.

Fifth Round—2 d. c., ch 2, 2 d. c. all in each space of fourth round, and between the spaces put 2 ch. The work must be kept flat, and to do so it may be necessary for some workers to change the number of ch in the rounds.

Sixth Round—1 s. c. in each space between clusters of preceding round, 7 d. c. in the center of each cluster. This completes the center of the wheel.

For the border of the wheel continue as follows: 1 s. c. in the center stitch of each shell of preceding round, and between the shells ch enough to keep the work flat.

Second Round of Border—1 s. c., 11 d. c. and 1 s. c. in each loop of preceding rounds.

Third Round—1 d. c. in every third stitch and 3 ch between. When finished, this round should have 56 spaces, and it may be necessary to change the amount of skipped stitches to bring the spaces right.

Fourth Round—2 d. c., 2 ch, and 2 d. c. in every second space of the round, 2 ch between the clusters. Repeat fourth round, working the clusters in the center space of the clusters of the preceding round, then work a final round like the final round of the center. Fasten off.

For the wheels around the center again make a thick ring of cotton over the tip of the finger, and in it work 28 s. c. Join.

Second Round—1 s. c. in first stitch, \*ch 4, skip 3 stitches, 1 s. c. in next, and repeat from \* to end, joining the last ch to the first s. c.

Third Round—1 s. c. and 8 d. c. in each ch loop of preceding round.

Fourth Round—1 d. c. in each s. c. of preceding round, 10 ch between. Join last ch to first d. c. On this round work the first 4 border rounds, following the directions given for the center.

Fifth Round of Border—Work like the fifth round of the border for the center wheel, but join the center stitch of the first 3 scallops to the center stitch of the first 3 scallops of the center wheel. At the end of the round fasten off.

For the remaining 6 wheels follow the directions given for this wheel, excepting for the joining, which is done as follows: Skip 1 scallop of center and join the first 3 scallops of the second wheel to the next 3 scallops of center. Work all around to within 3 scallops of the end, join the next 2 scallops to the corresponding scallops of the first wheel, leaving one scallop on the latter between the side joining and the center joinings. Make half of the next or final scallop of the second wheel, ch 3, catch in unjoined scallop of center between first and second wheels, ch 3, catch in unjoined scallop of first wheel, ch 3, again catch in center, ch 3, catch in last d. c. made in uncompleted scallop of second wheel, finish that scallop, and fasten off.

All the wheels are joined like the second wheel, excepting the last, which is joined also to the first wheel and to the center in the scallop before the first wheel.

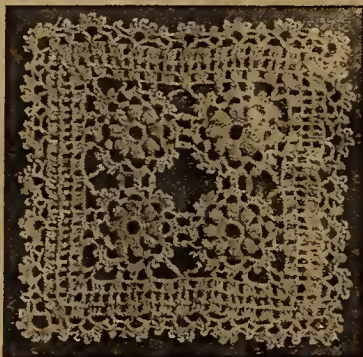

A bedspread made of these crocheted squares is very attractive

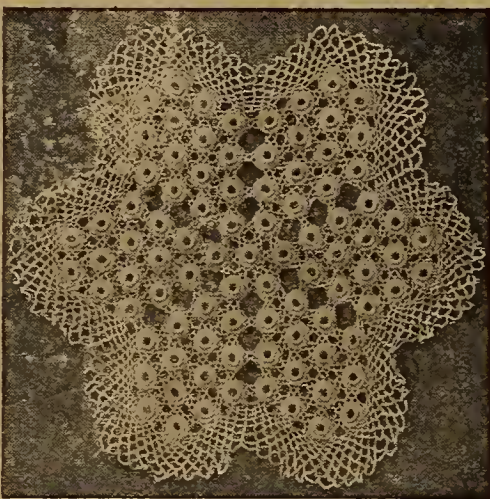

An effective centerpiece crocheted in tiny rings



Crocheted centerpiece made of wheels joined together

## The New Rural School

By Cora A. Thompson



**T**HE Country Life Commission recommended "a new kind of country school." It should have said a new kind of country parent. Who has the right to demand a better and different rural school? Isn't it you and I, Mr. Farmer? Don't we know better than anybody what kind of school the rural districts need? Can a body of men, no matter how intelligent, tell us our needs as well as we can tell them, if we will?

### Cooperation is Needed

The great need of the farmer to-day is cooperation not only in things scholastic, but commercial. The farmer is the coming man, and if he will but awaken to his needs and demand his rights his future is assured. He will tell Wall Street what to do. But firstly, he must be educated.

"We think that old Aladdin's lamp, which brought him wealth and station, had, on its base, this potent word of magic—'Education.'"

What a sculptor can do to the clay, education can do for the farmer. Doesn't it pay to acquaint your boy and girl with plant life in its development? Did you take your boy and girl out to the field with you last spring, and show them the beauty and the lesson in the young corn-stalk, holding its little upturned cup skyward to catch the rain and the dewdrop? Did you show them how covertly she hid the stored nourishment away to seep down and succor her thirsty roots in the time of drought? Did you point out to them the

glory of the sunrise never seen from the crowded city?

This is the A B C of a rural education. Wouldn't it pay you to train your child's mentality until it could grasp the beauty of the opening bud? What satisfaction would come to a boy to be able to tell the needs of the soil? We know the exhilaration which comes from growing knowledge of our work. Your child has the same feeling. The expansion of mind, the growth of power takes the drudgery from his work the same as yours. Teach him to commune with nature and that will inspire respect for country life. What city child could visit an art gallery this afternoon and find upon canvas the picture my children can see from our windows?

### Instil in Your Child a Love for the Country

Under the spreading canopy of a huge maple, all red and gold, russet and green, the horses and cows are resting. The sheep are browsing away 'midst goldenrod and asters; a pastoral scene, the beauty of which I want to impress upon my child, as my desire is for my children to love the country, and as they grow to womanhood to work for the ideal country conditions in home and school. In the name of the farmers all over this country of ours, I demand a better rural school.

Last year, at one of our country school entertainments, two of the pupils read a future prophecy of the school. I am sorry to say that each and every pupil was transported to the city. What's the matter,

parents? Aren't you teaching your boy and girl that God made the free and independent country, but man made the city with its snares?

### What the Country Boy and Girl Need

Instead of free tuition to a high school, they should have free tuition to an agricultural college supported by the state. The boys should be taught the proper knowledge of farming in all various branches; also, the veterinary art, that he may protect his stock; he must be a mechanician, that he may properly manipulate his farm implements; a knowledge of forestry should be taught him, that he may protect our forests instead of devastating them. Also, horticulture, that he may care for his fruit.

The girls should have a most thorough course in household economics; also, chicken and turkey raising; the knowledge of how to treat wounds, etc. A vast field suggests itself that a farmer and his wife should know.

### Start Your Children Right

A half-developed human being is not a man. Are we trying to-day to develop farmers, preachers, teachers, lawyers, statesmen and politicians out of our men and women, or, rather, are we trying to make out of our politicians, statesmen, lawyers, teachers, preachers and farmers MEN AND WOMEN?

To-day there is demanded of us not theory or speculative philosophy, but hard-headed common sense. Training is every-

thing! The peach was once a bitter almond. The cauliflower is but a cabbage with a college education. The little old red schoolhouse of other days is fast becoming a memory. Our ancestors were earnest in their desire to furnish educational opportunities, and noble men and women were the products of the little log or frame schoolhouse of memory. We count our progress by outward and visible signs, Mr. Farmer. Let's awaken!

The Japanese say, "Everything big in your United States." So we, the farmers, demand of Uncle Sam a big education. You know our present college course won't prepare our boys and girls for the actual life-work of the everyday world. The work of the scholars should be a preparation for life, not a means to temporarily unfit the recipients. How many brilliant scholars I know who are like fish cast up by the waves on the beach. In the world of theory they can swim; out on the beach of commerce and livelihood their fins are useless. One of our practical business men said of one of them, "Oh, he's always soaring after the infinite and dying after the unfathomable, but never pays cash."

### An Appeal to Every Farmer

Mr. Farmer, now is the time for you to think how to live, and what it is to live. Wake up and better the conditions of the coming farmer by demanding it for yourself. There is strength in unity. Let us remember this and join forces for a new and better rural school!



# OUR YOUNG FOLKS



## Cousin Sally's Letter

DEAR BOYS AND GIRLS—  
Last time I told you that I had just returned from a little vacation in Nantucket. Well, since then I have had another great big vacation. I've visited the North, the South, the East and the West—even Central America and Canada, and I am so enthusiastic about it all. It was just as though I had had a fairy airship all my own, and had gone away over the hills and mountains and rivers and lakes to visit you. Uncle Sam was the fairy airship in this case, though, for he brought me heaps and heaps of letters from boys and girls everywhere. Such letters they were, too! I wish that I could show them to you—at least some of them. They were all about how you spent your vacation, and were so chatty and personal that I felt, after reading them, as though I had been making a tour of the country and visiting each one of you in your own homes.

One of the cousins who lives out West told me everything he did during vacation days. And they were busy days, just as busy as any of mine here in this big, tall, office-building. I think, however, that if I could, I would gladly exchange places with Bob and go away out West to live on a farm. You have all told me such interesting things—one boy told how he milked three cows every morning just after sunrise; how he fed all the scratching, hungry lot of chickens, looked after the pigs, helped turn the washing-machine for his mother on wash-day; how he carried the water and wood, hoed the corn, weeded the garden and gathered the eggs—and, oh! so many, many things that I can't possibly remember them all.

But he is not the only one of my cousins who has had a busy vacation. No, indeed. I do think that all my boys and girls have been just the busiest little people in the world. I feel so proud of you. Do you know, in all the hundreds of letters awaiting me on my return from my little holiday there was not one from a girl or boy who had been spending a selfish or a lazy vacation. Some of my girls have been earning money from their own little vegetable-gardens to pay for their fall school dresses. Others earned money picking berries for their parents. Many of the girls who are clever with the needle have formed sewing circles and are making their Christmas gifts and little articles for fairs. Aside from this, many of the girls have been relieving their mothers of the cooking, or have been assisting them in other household duties, during the warm summer days.

You deserve a great deal of credit for the good work you have done this summer, and while many of you may think that helping in the home is not so important as helping others outside your home—still I do not think anything can be lovelier and make one feel happier, when the vacation days draw to a close, than to know one has helped mother—and made things easier for father.

Now, good-by for this time. Write to me soon. Tell me how you like our Bulletin Board. Many of our readers are very enthusiastic over it, and when any of my new ideas for the page meet with success, I can't tell you how it encourages me to do still better things. I feel happy and light-hearted, just the way you feel when teacher pats you on the head and says, "Well done, little girl."

With love to you all,  
Faithfully always,  
COUSIN SALLY.

## The Roll of Honor

THE work of the following cousins was found to be exceptionally good and worthy of special mention on our page:

Florence and Mina Larabee, Copenhagen, New York; Lorraine Roye, Anna L. Flory, Pequea Creek, Pennsylvania; Bertha Mag-sig, DeWitt, Michigan; Emma Petersen, Minden, Nebraska; Clara Achttien, Indianapolis, Indiana; Lillian Mueller, Oakley, Michigan; Emma Corbett, Grand Island, Nebraska; Aleta Webb, Centerburg, Ohio; Lily Ellena Lemon, Havana, Kansas; Eloise Case, South Royalton, Vermont; Sheridan M. Benjamin, Conneaut, Ohio; Edith Hinds, Thomson, Illinois; Iloene Miller, Sabina, Ohio; Gertrude Crabtree, Victor, Oregon; Hazel Rae Branum, White Lake, South Dakota; Lucille Skilton, Ravenna, Ohio; Ruth Leonard, Waukesha, Ohio; F. L. Etta Dissmore, Dallas, Wisconsin; Lenora Banks, Hillman, Michigan; Genevieve White, Barneveld, Wisconsin; Walter Ochsenhirt,

house in a maple-tree, another in the wistaria-vine over the dining-room window. The bee-bird and catbird also have nests near the house, and the martin-box is full. Sometimes when I play the piano a bird sits in the peach-tree and sings.

BETH KNOTTS, Nora, Indiana.

Here is a little story by Violet Steidtmann, aged eleven, Merrimac, Wisconsin, that perhaps you boys and girls may enjoy reading:

### A Bird Story

In our bedroom there is a window on the east side that is half covered with a wild-grape vine.

One day a bird came and rested on the grape-vine. It twitted and chirped and seemed pleased, until it turned around and looked into the window. As it looked it saw its own shape reflected on the window-pane.

Now, some birds are pleased if they see their image, but this bird was not. It gave a peck at the glass and then flew away as if to pick up courage to fight its enemy. Then it pecked and flapped its wings at it, and every day for a week or more after it came there to fight what it thought was another real bird.

VIOLET STEIDTMANN,  
Age Eleven, Merrimac, Wisconsin.



Sewing for Their Dolls

This is the way many of our girl club members spent their vacation

Glenshaw, Pennsylvania; Eloise Leitch, Spencer, Iowa.

## Cousin Sally's Club

DON'T you want to join our club and find out the secret meaning of our monogram? The club button is most attractive. Its colors are blue and white, and you are sure to like it. It costs only five cents. Any boy or girl not over seventeen years of age is eligible for membership. When writing for a button, enclose five cents in stamps and address Cousin Sally's Club, 381 Fourth Avenue, New York City.

## The Letter-Box

DEAR COUSIN SALLY—  
I am ashamed that I have not written sooner, but my music lessons keep me busy. This morning I thought I would write and tell you about the birds that are nesting around our home.

I have a play-house out under the trees, but as I spend most of my time in piano practice, I do not have much time to spend in the play-house. After an absence of two or three days, I went out to see if the mud pies were done and found a wren had taken possession. She had built her nest in a bowl that sat on one of the cupboard shelves. Day by day a new egg was added until there were seven little speckled eggs in the nest.

One morning I went out and found the nest scattered on the ground. The little eggs were gone and the wren no place to be seen. I fear a cat killed her, but perhaps she escaped, as I saw no feathers.

A mocking-bird has its nest in the grape-vines. A robin's nest hangs over the wood-

good view of the lake. The lake is mostly surrounded by a small grove. The cottages are nearly all filled now, as it is the time of year that most campers like. The fishing is not very good at times, although there are spells when we catch quite a lot. Some of the cottages have such names as "Pleasant View," "Uneeda Rest," "Bonnie View," "Dew Drop Inn," "Rushmere," "Kil Kare," "Seldom Inn." Ours is "Linger Longer."

I love to belong to the "C. S. C." I am deeply interested in our page.

MARION V. SABIN,  
Box 86, Homer, Michigan.



Don't Use Laundry Soap on Your Face

## JAP ROSE

"The Bubble Bath Soap"

is unequalled for cleansing your skin because it is the original, transparent Toilet and Bath Soap and is absolutely pure. Because it is made of vegetable oils, it cleanses instantly, thoroughly and refreshingly. For genuine pleasure and satisfaction insist on getting

## JAP ROSE

Sold by dealers everywhere

REFUSE IMITATIONS

Look for the Jap Girl on every package.

A Large Cake for 10c



Established 1839

84

## WE WANT A MAN

or woman in every community to handle the best money-making offer ever made by any publisher. Liberal pay for whole or part time. Special cash prizes each month for special merit. Supplies and instructions free. Any one of average education and ability can make good money and build up a permanent business. Apply, giving references, to

FARM AND FIRESIDE  
Dept. S Springfield, Ohio

## Our Bulletin Board

The prize-winners in the June 10th contest are as follows:

**Pendants**—Gladine Stansberry, age twelve, Little Falls, West Virginia; Mildred Smith, age twelve, Everson, Washington, and Beth M. Nichols, age thirteen, Brentwood, Long Island.

**Jack-knives**—Clarence De Witt, age eight, Lawton, Oklahoma; Conrad Dirlam, age sixteen, Honesdale, Pennsylvania, and Maurice H. Pancoast, age sixteen, Lansing, Michigan.

**Books**—Chloe Bugbee, age fifteen, Lyons, Michigan; Marie Cobb, age fifteen, Brownville, Maine; Norma Fewings, age eleven, Elmwood, Illinois; Lucile Bull, age twelve, Trundles Cross Roads, Tennessee, and Anna Margeson, age twelve, Castlewood, South Dakota.

Carrie Burt, a little girl from Macy, New Mexico, is anxious to exchange post-cards with some of the cousins.

One of the busiest little girls in the club this summer is Jennie Davis, of Eagleville, Missouri. She helps her mother with the work at home, sews, and yet finds time to take long rides on her horse.

A bit of happy news came to Cousin Sally's Club some time ago. Elizabeth Smith, age eleven, of Cassadaga, New York, passed all her June examinations and will be in the seventh grade in the fall.

Harriett Apgar, age fourteen, R. F. D. No. 1, Morrow, Ohio, and her little chum have formed a sewing club. The members meet once a month. Why not meet once a week, Harriett? Harriett would like to exchange post-cards.

Vertilee Stinson, age twelve, R. F. D., Box 62, Stonington, Maine, is sick nearly all the time and would be so happy to receive bright, cheerful little letters or post-cards from you.

One of our boys, Richard S. Wing, of West Toledo, Ohio, is most industrious. He raises rabbits and sells them for pets. He writes that he has seven pretty bunnies.

Blanche Kennedy's needle has been fairly flying this summer, sewing a patch-work quilt.

On Arbor Day, Flossie Miller, of Amsterdam, New York, dedicated a tree to Sir William Johnson and gave it his name.

Clarice Turner of Villa Rica, Georgia, is an enthusiastic cyclist. She loves nothing better than to take a spin down the road.

What is your favorite game, and how do you play it? I want to collect a number of games from our boys and girls, and print them on our page. It will be a sort of exchange idea, you see, and I know you will all be interested in finding out the kind of games other girls and boys play. Won't you send your "pet" game along right away, for I want to get up this page just as soon as I can.

Have you heard any new riddles lately? If you are interested in riddles and will send me one or two good ones, perhaps I'll start a "Riddle Box." One of the cousins suggested this idea. How does it strike you?

Don't fail to see the charming two-part story in our next number. It is called "Kita and the Three Firesticks" and is brimful of exciting moments. You are sure to like it. It will be beautifully illustrated.

If you have lost your club button, you can obtain another one by sending Cousin Sally five cents to pay for it.

Cousin Sally's address is FARM AND FIRESIDE, 381 Fourth Avenue, New York City.

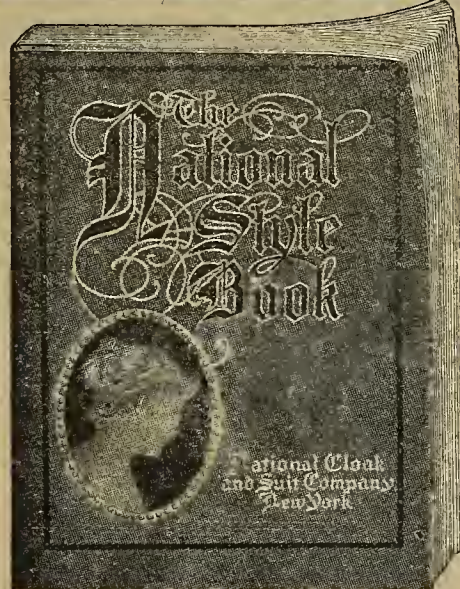

Copyright, 1911, by National Cloak & Suit Co.

## This is Your "NATIONAL" Style Book

This is the complete Fashion Book of the "NATIONAL," the largest Ladies' Outfitting Establishment in the entire world.

This book will show you the best New York styles in all kinds of apparel for Women, Misses and Children, and it offers all at "NATIONAL" prices, which mean a big saving to you. It will be time well spent for you to write for this Style Book. It will be sent you entirely free and without obligation. Write now for your copy and find out about the "NATIONAL" and learn what styles are to be worn this Fall.

## Do You Know the "NATIONAL"?

During the Spring and Summer of 1911, over one million women bought their clothing by mail of the "NATIONAL." These women live in every county—in every State—in America.

Now let us reason this out fairly. Why, we ask, why did one million women find it profitable and desirable to send to the "NATIONAL" for their apparel? Why for 23 years has the "NATIONAL" been the leader in selling women's clothes? Isn't there a possibility of satisfaction and saving for you? Isn't it worth while investigating? It costs nothing but the time required to write for the Style Book pictured above.

This Style Book will Show You  
Waists, 98c to \$10 Petticoats, 98c to \$6.98  
Skirts, \$3.98 to \$15 Furs, \$2.25 to \$42.50  
Dresses, \$10 to \$30 Ladies' Coats, \$10 to \$50  
Hats, \$2.98 to \$15 Misses' Suits, \$10 to \$20

## "NATIONAL" Tailored Suits

Made to Measure \$15 to \$40

Each Made to Measure suit is actually cut and made to order and each is guaranteed to fit perfectly, or we will refund your money. In writing for your Style Book, be sure to ask for samples of materials for "NATIONAL" Tailored Suits and state the colors you prefer. Samples are sent gladly, but only when asked for, and they are well worth asking for.

### The "NATIONAL" Policy

We prepay postage and express charges on all our garments to any part of the world. You may return at our expense any "NATIONAL" Garment not satisfactory to you, and we will refund your money.

**NATIONAL CLOAK & SUIT CO.**

283 West 24th Street, New York City

Mail Orders Only No Agents or Branches

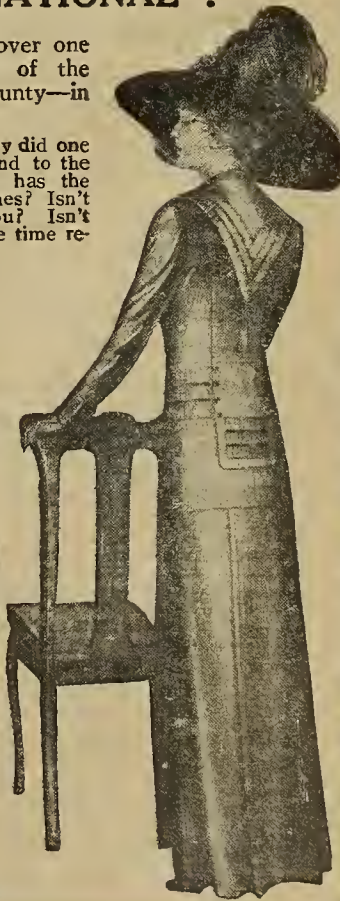

# Mid-Season Clothes For Little and Big Folks.

Designed by Miss Gould



Thrifty women are not "penny wise and pound foolish" in buying cotton dress-goods. They select **Simpson-Eddystone Prints**

Every step in the manufacture of these substantial calicoes contributes to the wearing-quality as well as to fine appearance. The cloth is well-woven and lasting; the colors are absolutely fast; and the designs are strikingly beautiful and attractive. The standard Prints since 1842. "Worth making up."

Show this advertisement to your dealer when you order, and don't accept substitutes. If not in your dealer's stock write us his name and address. We'll help him supply you.

The Eddystone Mfg. Co., Philad'a  
Founded 1842 by Wm. Simpson Sr.

**I Trust You Ten Days. Send No Money. \$2 Hair Switch Sent on Approval.**  
Choice of Natural wavy or straight hair. Send a lock of your hair, and we will mail a 22 inch short stem fine human hair switch to match. If you find it a big bargain remit \$2 in ten days, or sell it and EARN YOUR OWN SWITCH. Extra shades a little more. Inclose 50 postage. Free beauty book showing latest style of hair dressing—also high grade switches, pompadour, wigs, puffs, etc. Women wanted to sell our hair goods.

Anna Ayers, Dept. A277, 22 Quincy St., Chicago



No. 1424



No. 1813



No. 1812 and No. 1813



No. 1812

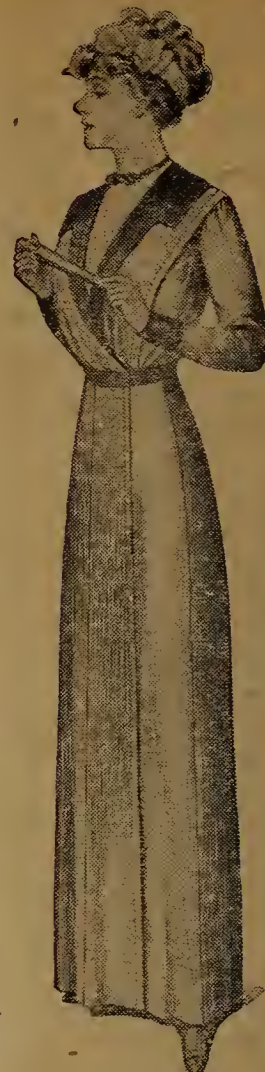

No. 1626

**No. 1813—One-Piece Dress, Buttoned on Shoulders**

Pattern cut for 1, 2, 4, 6 and 8 years. Quantity of material required for 4 years, one and five-eighths yards of thirty-six-inch material, with one-fourth yard of contrasting material for trimming and one yard thirty-six-inch material for the guimpe. Price ten cents

**No. 1812—One-Piece Dress with Panel Front**

Pattern cut for 6, 8, 10 and 12 year sizes. Quantity of material required for medium size, or 8 years, five and one-eighth yards of twenty-two-inch material, or three and one-eighth yards of thirty-six-inch material. The price of this pretty pattern is only ten cents



No. 1424

**No. 1424—Empire Dress—High or Low Neck**

Pattern cut for 32, 36, 40 and 44 inch bust measures. Quantity of material required for medium size, or 36-inch bust, eleven and three-fourths yards of twenty-two-inch material, or seven and one-half yards of thirty-six-inch material, with seven eighths of a yard of all-over lace for yoke and undersleeves. This is an excellent model for a simple afternoon dress developed in silk or cashmere and trimmed with satin. Price of this pattern is ten cents

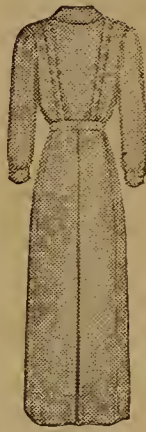

No. 1548

**No. 1548—Morning Dress with Buttoned-Over Front**

Pattern cut for 32, 34, 36, 38, 40 and 42 inch bust measures. Quantity of material required for medium size, or 36-inch bust, nine and five-eighths yards of twenty-four-inch material, or five and seven-eighths yards of thirty-six-inch material. Developed in madras and linen this morning dress is serviceable and good looking. Pattern costs ten cents



**No. 1626—Coat Dress with Adjustable Chemisette**

Pattern cut for 32, 34, 36, 38, 40 and 42 inch bust measures. Quantity of material required for medium size, or 36-inch bust, six and three-fourths yards of thirty-six-inch material, or five and one-fourth yards of forty-four-inch material, with seven eighths of a yard of contrasting material for collar, cuffs and belt. When a street dress for early fall wear is required this model would be very practical made of serge. The price of this pattern is ten cents



No. 1670  
No. 1671

**No. 1670—Waist with Yoke and Sleeves in One**

Pattern cut for 32, 34, 36 and 38 inch bust measures. The price of this pattern is only ten cents

**No. 1671—Scant Four-Cored Skirt**

Pattern cut for 22, 24, 26 and 28 inch waist measures. The price of this pattern is only ten cents



Pattern No. 1548

**No. 1804—Misses' Tucked Dress**

Pattern cut for 12, 14, 16 and 18 year sizes. Quantity of material required for medium size, or 14 years, six yards of twenty-two-inch material, or three and five-eighths yards of thirty-six-inch material, with one-half yard of contrasting material for trimming. The price of this pattern is ten cents



No. 1670 and No. 1671

## FIFTY Beautiful Post-Cards Assorted Subjects —For— Farm and Fireside Readers

We have just concluded another Post-Card deal which enables us to offer our friends an assortment of fifty cards of the very best quality and design, absolutely without cost.

These cards are without doubt the acme of post-card production. They are lithographed in many colors and the designs are new, original and attractive.

### You Will Want These Cards

And we want you to have them. The subjects are many and varied, and can be applied to all occasions, such as Birthday Greetings, Best Wishes, Good Luck, etc.

We give you our positive assurance that a finer assortment of Post-Cards cannot be obtained anywhere. These cards are the best in every particular.

### Write To-day for Particulars

We will reply immediately telling you how you may obtain this fine assortment of high-colored, high-finished, high-priced Post-Cards without a cent of cost to you.

Write at once. Address

**FARM AND FIRESIDE**  
Post-Card Department, Springfield, Ohio

**LEARN JEWELERS' ENGRAVING**  
A high salaried and easily learned trade, taught thoroughly by mail. We will teach the beginner better engraving than he can gain in years of rigid apprenticeship. We will also improve the skill of any engraver. Send for our catalog. The Engraving School, 25 Page Bldg., Michigan Ave., Chicago, Ill.

**LEARN TO WRITE ADVERTISEMENTS** **EARN \$25 to \$100 A WEEK**  
We can positively show you by mail HOW TO INCREASE YOUR SALARY. Book mailed free. Page-Davis, Dept. 25, Chicago Ill.

**DON'T PAY TWO PRICES**  
Save \$18.00 to \$22.00 on  
**HOOSIER RANGES AND HEATERS**  
Why not buy the best when you can buy them at such low, unheard-of Factory Prices? **THIRTY DAYS FREE TRIAL BEFORE YOU BUY.** Our new improvements absolutely surpass anything ever produced. **SEND POSTAL TODAY FOR OUR FREE CATALOG AND PRICES.**  
Hoosier Steel  
**HOOSIER STOVE FACTORY** 126 State St. Marion, Ind.

### How to Get the Patterns

If you want clothes that are right in style and yet practical, use the famous **WOMAN'S HOME COMPANION** patterns which we supply at the very low price of ten cents each.

So great has been the demand among **FARM AND FIRESIDE** readers for our **WOMAN'S HOME COMPANION** patterns that we have established three offices or depots from which these patterns can be obtained, as follows:

Eastern depot: **FARM AND FIRESIDE**, 381 Fourth Avenue, New York City.

Central depot: **FARM AND FIRESIDE**, Springfield, Ohio.

Western depot: **FARM AND FIRESIDE**, 1538 California Street, Denver, Colorado.

#### A Premium Offer

To any **FARM AND FIRESIDE** reader who sends us one new subscription to **FARM AND FIRESIDE** with fifty cents for the same, we will give as a premium for the subscription one **WOMAN'S HOME COMPANION** pattern. To obtain a pattern without cost, send the subscription to **FARM AND FIRESIDE**, Springfield, Ohio.

# What Makes Beefsteak Taste Good

By Eugene Wood, Author of "Back Home," Etc.

Drawings by Fred E. Lewis



"Partaking only of pure cold water"

SOME time, when you have nothing better to do, you can look over (in your mind) the various things you take a pleasure in, and figure out how much of that pleasure is due to out-and-out wastefulness, and extravagance.

For instance, we'll say you have a pretty front yard. You take a pride in it, and so does "the old lady," and people driving by slow up, if they don't stop, and say: "Well, I call that pretty fine." They see the lawn clipped like so much green velvet, and the flowers blazing like gems of different colors. It is a delight to the optic nerve and a pleasure to most of the other delicate senses.

The grass must grow thick and even; no bare patches or places where the plantain and dock and wild carrot and dandelions have been allowed to take possession. And it must be cut short, and not allowed to grow up to seed. There must be no weeds in the flower-beds, and no poor, spindling, half-dead and half-alive plants. They must look thrifty and as if they took pride in their personal appearance.

Now, I don't know whether you know it or not, but that takes work. And a front yard to be really delightful must show that it takes work, a lot of work, but that work must not be useful work. That would spoil everything. If you let the grass grow tall, it would look as if you meant to get hay off the front yard. There is no money in grass-clippings. The soil must be good, it must show that it is good, and yet, though corn is certainly as graceful and beautiful as any ornamental plant, corn or potatoes—potatoes have a pretty blossom, too—wouldn't do in the front yard at all. Flowering currants, yes, but not currants that you can make jelly of; Japan quince, yes, but not real quinces that grow preserve stuff.

## Extravagance and Wastefulness Are Loud Personal Advertisements

I'm not scolding, understand; I'm not censuring you for wasting your time on what doth profit you nothing; I'm only telling you that nothing is really lovely to the eye unless it shows in some way that you aren't poor folks, that have to use up every inch of fertile soil, and have to lick

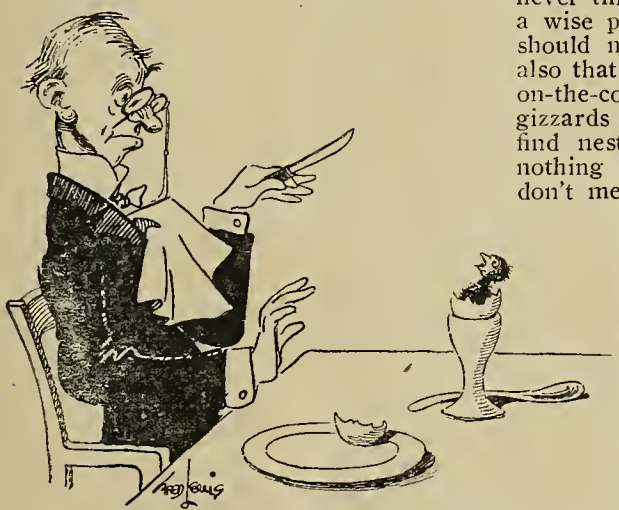

"In town a body has to pay five cents for eggs"

into it from daylight till dark to make both ends meet. To be really respectable, to be artistic, to have anything like a good time, you must be able to show that you don't have to work for a living; you must advertise that fact loudly. That's why diamonds are such an ornament, and real, hand-painted pictures, though the drawing and coloring in a chromo may be just as well done.

You think it over. I don't want to do all the work. You take anything you like that men esteem—and women, too—and figure out how much of the esteem it has is due to the fact that advertises plenty, such plenty that you can afford to be wasteful.

What I want to do right now is to apply this principle to food. Personally, and as far as mere eating is concerned, I had as lief have tow stewed in flour-paste as an artichoke, yet when I went to a dinner not long ago, and there were artichokes, I felt mightily flattered because I know just how expensive these cultivated thistle-blossoms were. Oh, they're terribly dear. Most of them have to be imported from France, because it's so hard to get bull-thistles to grow in America. You'd noticed that, hadn't you? And besides, anything that has been brought over the ocean or even freighted across the continent in stuffy box-cars is always so much more desirable, to some people, than fresh vegetables, home-grown and hand-picked.

You people who are still out on the farm don't consider as carefully how food can be used as an advertisement of plenty as we do who have left the farm a generation or so ago, without having taken the precaution to keep our clutches on it still, and exact a rent of half the net crop. We have to go through at least the motions of earning our own living, and now that so many more have deserted the country for the town so that the agricultural population is actually declining in spite of the loud cries of "Back to the Land!"—now that the farm population has actually decreased, instead of only relatively decreased, food is daily becoming more like a work of art than a common vulgar necessity.

## The Farmer Takes a Well-Set Table for Granted

With you it is different. The hens scratch around the barn and chase bugs in the fields. They pick up perfectly good grains of corn where you and I would never think of looking for food, it being a wise provision of nature that chickens should not be too blame particular, and also that pigs and such four-footed corn-on-the-cob feeders should not have any gizzards to speak of. When the children find nests in the hay-mow, why, that's nothing out of the common. The eggs don't mean expense to you. They don't go on the unhappy side of the account with the grocer. And should any fat cockerel happen to get something in its eye, and you take the fowl up to look and see, and it should get excited and flop around till it finally lost its head altogether and you, not wishing the poor thing to go to total waste, should scald it and pick it and draw it and put it in the pot, why, that doesn't go on the unhappy side of the account with the butcher, either. And the

same way with the hog-meat hanging up in the smoke-house, and the cakes of sausage in the big stone crock, all deeply imbedded in the lard. These are as natural to you as the fresh air and the cool spring-water.

In town it is different. There a body has to pay five cents apiece for eggs that he can gulp down without a shudder, and the thoughts of what he will be like six weeks after the funeral. The chickens a body eats in town are not yellow; they're more likely to be a kind of bilious green. There's a long distance in quality between the hen-house chicken and the cold-storage-house chicken. You never heard of a cold-storage warehouse being robbed of its chickens, but anybody who's lived in town very long can easily understand the longings which drive one to pick the lock of a hen-house and depart with a fat broiler.

Whatever style we in town may put on because of fresh eggs, and fresh-killed poultry, you can hardly comprehend. It would be like a woman making a party-dress out of gingham. But when it comes to beef, country people and town people are about alike, now that neighbors no longer slaughter, and supply each other with fresh beef, turn and turn about. All of us, I fancy, are of the notion that, of all food, a nice beefsteak just about fits our faces.

We may have some slight difference of opinion as to what constitutes "a nice beefsteak;" some like it cut to the thinness of a piece of blanket, others to the thickness of a man's hand; some like it pounded up like a prize-fighter's face at the beginning of the thirtieth round, others won't have it so much as scored; some like it fried a rich, dark brown, with plenty of white gravy to sop their bread in, while others want it broiled a golden brown with the juice springing from under the knife. But to all of us "a nice beefsteak" is an agreeable thought.

It is hard for us to imagine how people can turn from a beefsteak with loathing to fill up on nuts and apples and raw wheat. It is even more difficult for us to be patient with those who preach that the only reliable cure for all ills that flesh is heir to, from gun-shot wounds to toe-corns, is to go without eating entirely for a month or two, partaking only of pure, cold water. To be sure, it is a medicine mighty hard to take, and anything that is hard to take should be a sure cure; but then, look how cheap it is. That's against it.

When sensible folks like you and me are so thoroughly agreed as to the desirability of a nice beefsteak, it seems that it must be the naturest of desires, and entirely uncontaminated by any wish to show off our wealth.

But let's look into the matter. Lots of things we know instinctively, and even, as you might say, prophetically, without being able to give the figures or the reasons.

Not long ago I met Dr. William P. Cutler, Commissioner of the Missouri Department of Food and Drug Inspection

at Columbia, Missouri, where they have the state agricultural college. They putter along with cows and dairy products at the Missouri State Agricultural College, in a half-hearted way, as you will understand when I tell you that there are only twenty Jersey cows in the world that have ever yielded more than seven hundred pounds of butter in a year, and of these twenty the Missouri Agricultural College has five, bred on the farm. Altogether, they have a herd of more than three hundred of seventeen different breeds. It may be that I am unduly credulous, but information from such a source I do not feel like turning up my nose at and sneering, "Aw, that's all poppycock!"

Now let me tell as straight as I know



"Food is daily becoming more like a work of art"

how what Doctor Cutler told me. He said that they took a cow that gave 18,405 pounds of milk a year, and estimated the food-values in that milk. Without any slurs about the cow with the iron tail, you will understand that a large part of milk is water. But the solids were like this:

Protein .....	552 pounds
Fat .....	618 pounds
Sugar .....	920 pounds
Ash .....	128 pounds
Total food-values,	2,218 pounds.

Next they took a two-year-old steer that weighed 1,250 pounds and ground it all up into a pulp, hide and all. And from that they took the following table of contents:

Protein .....	172 pounds
Fat .....	333 pounds
Ash .....	43 pounds
Total food-values,	548 pounds.

Understand that this is the gross food-values, not the net. A steer is not a pig, of which all is food except the bristles and the squeal. A steer will not cut up into steaks and stew-meat all the way through. But even so, suppose it did, what the steer had eaten up in two years produced not quite one quarter of the food-value of what the milch cow had eaten up in one year.

Also, the steer was done. All through. No more. Whereas, the milch cow was as good as new, maybe better than new, and capable of turning out a long ton of clear, solid, utilizable food for ten, twelve, perhaps fifteen years to come.

Now, this is interesting information of itself, but what I prize highest about it is the light it sheds upon why beefsteak tastes so good; it's the strong flavor of money in it. It's the extravagance of it.

## Success in Marketing Poultry and Eggs

[CONTINUED FROM PAGE 4]

deliver the eggs to the manager of the association every day or two, and they should be stamped in one of the ways described by this local manager as soon as received.

All eggs produced should be delivered at the earliest possible time to the local manager. If two dozen eggs are produced on the average farm each day during the height of the egg-producing season, fifty farmers would be able to deliver one thousand eggs a day. All eggs received by the local manager should be inspected carefully soon after their arrival, and should be sorted and arranged according to the best judgment of the manager. One of the first things would be to put all small eggs together and large eggs together, also light-colored eggs together and dark-colored eggs together. Care should also be taken to see that duck eggs, guinea eggs, turkey eggs, etc., are kept in their separate places. The manager also would see that the eggs were classed according to their grade. It is very desirable to separate "rots" from "cloudy" eggs and "cloudy" ones from "musty" ones, and each of these classes from the good eggs.

Each farmer should be credited with the number and kind of eggs which he delivers and he should be given an opportunity to examine all eggs refused, whenever he sees fit, in order that he may know that he is being fairly treated.

One of the reasons why this inspection should take place before the eggs reach the city is the fact that it is an unjustifiable expenditure of hard-earned money to pay the freight or express on rotten eggs to some distant market. If this inspection is not done until the eggs have reached the city, it must be done there by the highest priced city labor, and this same high-priced city labor must be secured to haul the spoiled eggs to the garbage-piles or to other places where they may be destroyed.

But the saving in money is not the only important factor to keep in mind. This original inspection is necessary in order to be able to guarantee a fresh and reliable product to the consumers. At the present time large numbers of people in the cities are willing to pay a premium of from ten to fifteen per cent, for eggs which are guaran-

teed to be fresh, and the surest way to secure this premium is to have the eggs properly stamped with the date on which they were laid. The local society should guarantee that the date is correct, and must be ready to redeem the promises to send fresh eggs in every case where spoiled eggs have been found. Provision should be made so that the farmer who delivered the eggs would be notified and a scale of fines should be levied to pay the expense of supplying fresh eggs. In order to make sure that no misrepresentations are made, the egg-shell with the date and the farmer's number should be returned when claim is made for other eggs.

The total amount of saving by organizing a society as described above would be very great.

Farmers would receive cash for their eggs and would be able to buy their supplies for cash. This would get away from the old barter system, which is a relic of antiquity and should have been discarded with the old machines which were used during the last generation. As soon as a considerable number of local societies have been established in any

community they will find that they will oversupply the market during the summer months and will not be able to supply the demands during the winter months. These local societies, as soon as there are enough of them to warrant it, should form a central marketing society.

This central organization should keep in touch with large central cities like Chicago and New York, and should also keep in touch with the foreign markets. But they will find it necessary to establish a central storage plant where they can keep the eggs in the best possible condition until such time as the market is favorable.

What has been said concerning the marketing of eggs might well be said concerning the marketing of poultry. The problem is somewhat different, but the general principles are the same. Even the marketing of the feathers should be considered as an important part of the work of such an organization. Farmers are practically the only class who give very little consideration to the business side of their industry. It should not be so.

# The Little Trust

[CONTINUED FROM PAGE 14]

"Then, on second thought, you deem it better for me to give up my plan?" he asked. She shook her head in vigorous dissent. "But," he objected, "that would mean buying the farm on *nothing*."

"Precisely."  
"But, how is that possible?"  
"By making a little 'trust.'"  
He laughed at her feminine ignorance, but she insisted soberly:

"Don't the big trusts buy up property with other people's money, which they get by selling those people bonds and things?"

He nodded.  
"Isn't a mortgage something like a bond?"  
"Yes, they are a good deal alike."

"Well, now, if Dick should succeed in finding a real bargain—a *genuine* bargain—worth several hundred dollars more than you have to pay for it, mightn't it be possible to find someone who would take a *second* mortgage for the amount of cash you have to pay down on the property?"

"It does sound feasible," he admitted. "But the interest charges on second mortgages are generally higher."

"But wouldn't the interest you'd be getting from the savings fund on your own money offset that difference?"

"Wherever did you learn all this?" he asked in surprise.

"Oh, father was a very successful man," she explained, "and I've often heard him talking about these very things when advising his neighbors what to do, for they all depended on his knowledge and judgment. It seems to me it would be very wise for you to hold on to your money for a year or two as 'capital.' Besides, it certainly would be awfully interesting if you could work your plan out to a successful conclusion on *nothing*."

He turned upon her suddenly, and exclaimed admiringly, "I believe you could do that!"

"I rather think I could," she acquiesced naively. "But, you see, I'm giving you the advantage of all my experience and helping you all I know how."

"I'd come down to your farm to see Dick as often as possible," she explained: "for, if Dick were identified with the enterprise, I should feel almost like a stockholder in the little trust."

"Yes," he repeated absently. "Yes; you would have to be there *very* often." But he continued thoughtful and abstracted.

Several weeks passed, during which he remained strangely silent regarding the project that had previously seemed to occupy all his thought. Then, one evening, when he came home, he found that the girl, having finished her work, was waiting alone in the apartment for the return of Mrs. Carroll, who had gone out to purchase supplies for the meal.

It seemed as though he had been awaiting some such opportunity, for he instantly pulled a chair close to hers and sat down beside her.

"Well," he began, "I've thought it all over very carefully, and I've given up my plan."

She looked at him incredulously.  
"Oh, you don't *mean* it!" she exclaimed ruefully. "And it was all so beautiful, too! Why have you given it up?"

"Because your plan is so much better."  
She smiled in quick relief.

"Your 'little trust' idea has charmed me. But it has just one defect."

"Only *one*? Oh, that will be easy to remedy. Tell me what it is."

"The trust is *too* little. There's not enough of it. You and I don't trust each other sufficiently. We must have one of the 'big trusts.'"

"How big?" she asked faintly, her eyes wavering before his as a vague suspicion of his meaning began to filter into her mind.

He seized her hand.  
"The biggest that human beings ever make. Margaret, we must trust each other *completely*. I want you to trust yourself to me entirely. That *little* trust of ours needs this big trust to nurse and protect it. Say that you will go with mother and Dick to that farm as my *wife*! I love you. The farm itself has ceased to be a sufficient week's-end attraction to me—I want to look forward to *you*, Margaret, when I go down each Saturday during that first year."

She did not answer; neither did she withdraw her hand from his strong manly one. He sat upon the arm of her chair and, slipping a hand around her neck, drew her head to him.

"Say it, Margaret," he urged; "say that you'll go!"  
"I'll—I'll go with you, Bruce! Yes, I'll go with you *there*—or anywhere else in this wide world!"

Then, suddenly, her strong personality asserted itself, and she glanced up at him in defiant shyness.

"You see, I do *so* want that little trust to be a success!" she explained.  
"It's *sure* to be *now*!" he exclaimed happily.

There was the sound of a latch-key being inserted in the door. She struggled vainly to free herself, for he would neither stir nor release her.

Mrs. Carroll, entering with her little basket of supplies, found herself confronted by a spectacle that transfixed her.

"Bruce! Wh—wh—what are you doing?"  
"Mother," he said, springing forward and seizing her in his arms, "I'm working out that plan for lowering the cost of food-stuffs!"

"Are you quite sure you won't *raise* it?" she queried blankly, hardly knowing what she said.

"Yes and no," he laughed. "I'll *raise* the foodstuffs and *lower* the cost."

So, during supper, they told her all about their plan, and she listened with delight at the prospect of at last realizing her unspoken dream of living in the country.

It was as Margaret prophesied, for Dick did at last find a marvelous bargain in a delightful little farm within three hours' ride of New York City, at a ridiculously low price.

"Put me in charge there the first year, Bruce," said Dick positively, "and if, at the end of that time, I haven't maintained your mother, Mollie and myself; paid the taxes and mortgage interest; covered the expense of your weekly trips, and, in addition, improved the property from ten to twenty-five per cent., you can bounce me from the trust's service. Moreover, the terms this man has agreed to accept ought to make it the easiest thing in the world for you to get a second mortgage to the extent of the small amount of cash you'll have to pay down."

All of these things came true in due course; and the beginning of the second year found Bruce himself living upon the place and turned farmer in grim earnest under the skilful tutelage of the enthusiastic Dick who, with the aid of his energetic sister and the willing, if feeble, assistance of Mrs. Carroll, had indeed worked miracles of improvement.

"You see, Mother," cried Bruce triumphantly, as they sat on the porch one evening, "I've been as good as my word! Our little trust has brought the cost of your vegetables, eggs and poultry, milk and butter many per cent. nearer the zero mark! The corn-crop from the adjoining field we have leased will wipe the second mortgage off our property; and another two years of reasonably good results will clear off the first mortgage, leaving our home entirely free of debt. Of course, it's been hard work for all of us, but joyous work. In the city, we'd have worked nearly, if not quite, as hard, without the joy, and have had nothing to show at the end of it all. What a great deal we owe to Margaret, for without her wise counsel I'd have paid that money right out when we took over the property, thus hopelessly removing myself from the 'capitalistic' class. It's absolutely marvelous, Mother, what an unerring instinct she has for this agricultural business."

They both glanced over to a stretch of close-cropped grass, where an active figure—graceful in spite of its homely garments—was busily employed in hanging out "the ranch wash," as Dick called it.

"Thank God, Bruce dear, for His goodness in inspiring Mrs. Dixon to send me that girl!"

"Amen to that, Mother! Ay, *double* amen; for without her to 'promote' it, how could our 'little trust' ever have come into existence?—to say nothing of the glorious 'big trust.'"

## Farm and Fireside Cyclopedia

IN PLANNING to put away FARM AND FIRESIDE for future use, I first lay the copies away where the dust cannot get on them. After the papers for the year have accumulated, I bind them.

First, for the backs, secure two heavy cardboards about the same width as FARM AND FIRESIDE, but one inch longer. To cover both sides of the backs, glue a piece of cloth or heavy paper to them.

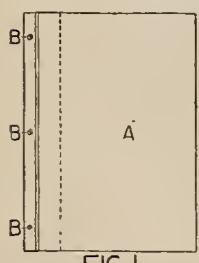

The way to do this is to have the cloth in one piece. Commence at the left-hand side of the front back and glue the cloth down, letting it run to the right. When you get to the edge, turn the back over and paste it on the other side. When edge, let it run over about two inches. This allowance is to go around the back for binding. Then commence gluing the

just as you did with the first one, only working from the inside. Finish up by bringing the binding cloth on over the binding, and gluing it to the first back. This will strengthen the binding. Fig. 1 is a side view of the cyclopedia. A is the back, B are small bolts to draw the book good and tight. Fig. 2 is an end view of the backs and binding-bolts. A good way to get the bolts through the paper is to use a brace and bit.

RAY MALCOLM.

EDITOR'S NOTE—Many of the readers of FARM AND FIRESIDE have saved all of the copies the past year, with the expectation of binding them, so this suggestion is a timely one. It is of value in connection with the fact that, after the September 25th issue, an index will be published. This will include all numbers of FARM AND FIRESIDE from October of last year to the close of September this year. Subscribers who desire this index will be supplied free of charge by the "Index Editor," FARM AND FIRESIDE, Springfield, Ohio. Write now. As soon as the index is completed, it will be sent to you.

**The Grocer's Answer**

"No, Madam, we don't sell soda crackers by the pound any more. "No matter what precautions are taken, bulk soda crackers absorb dust and moisture. In a few days the crackers become musty and soggy, and taste like most anything except a *good* cracker. "If you want a light, dainty soda cracker—a cracker that tastes as if it just came from the oven, then take home a box of Uneeda Biscuit. "These soda crackers are crisp and full flavored throughout. "When you get them home, open the package and you'll see how fresh, firm and flaky the moisture-proof package keeps them."

Never sold in bulk

5c

In the moisture-proof package

NATIONAL BISCUIT COMPANY

**Fortune-Telling Post-Cards**

In Sets of Twelve

A DIFFERENT card for each month in the year, showing the birthstone, the sign of the zodiac and a brief horoscope—witches, owls, crescent moons, black cats and all of the Fortune-Teller's paraphernalia. With these cards you can have loads of fun telling the fortunes of your friends. Tell them their lucky and unlucky months and days. You can tell them more about their characteristics than they know themselves.

**ALL FOR SIX CENTS**

postage. Send us three two-cent stamps, and in return we will send you, post-paid, a complete set of these new Fortune-Telling Cards. Send at once to

DEPT. E

FARM AND FIRESIDE Springfield, Ohio

**Cooling as an Icicle**

If you want to think of crisp winter weather and sparkling frost; if you want to forget the heat and the dust and the thirst for real, cool comfort

DRINK **Coca-Cola**

As sparkling, wholesome and refreshing as a spring house icicle. So next time you're hot or tired or thirsty, if you're anywhere near a place that sells Coca-Cola, go in and give yourself a real treat.

**DELICIOUS — REFRESHING THIRST-QUENCHING**

5c Everywhere

THE COCA-COLA COMPANY  
Atlanta, Ga.  
52

Send for our interesting booklet, "The Truth About Coca-Cola"

Whenever you see an Arrow think of Coca-Cola



# FARM AND FIRESIDE

THE NATIONAL FARM PAPER



ESTABLISHED  
1877

SEPTEMBER 10  
1911



A Special Live-Stock Feature Will Appear in the Next Number

# HARLEY-DAVIDSON

In one section of Indiana one out of every eight farmers own a motorcycle. These farmers have realized the economy, the convenience and the pleasure of this best of road steeds. Most of these machines are Harley-Davidsons. Selected because they are the most economical (they hold the World's record for economy). Because they are the most reliable.

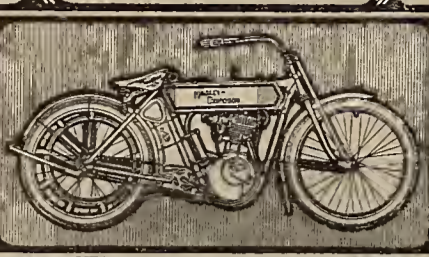

(In the New Jersey and Peninsular Motorcycle Clubs Endurance Contest, as well as the Cleveland Road Contest held this year, every Harley-Davidson entered, got a perfect 100% score. The average of the 11 other makes competing was 43%). Nearly one-third of all the motorcycles sold in America are Harley-Davidsons. Made and guaranteed in the largest exclusive motorcycle factory in the World. Send for catalog.

HARLEY-DAVIDSON MOTOR CO.  
875 L STREET MILWAUKEE, WIS.

## MINERAL HEAVE REMEDY

NEGLECT Will Ruin Your Horse  
Send today for only PERMANENT CURE  
SAFE CERTAIN

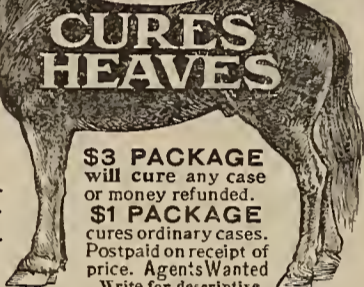

CURES HEAVES

\$3 PACKAGE will cure any case or money refunded.  
\$1 PACKAGE cures ordinary cases. Postpaid on receipt of price. Agents Wanted Write for descriptive booklet.

MINERAL HEAVE REMEDY CO., 425 Fourth Ave., Pittsburg

### THICK, SWOLLEN GLANDS

that make a horse Wheeze, Roar, have Thick Wind or Choke-down, can be removed with

#### ABSORBINE

also any Bunch or Swelling. No blister, no hair gone, and horse kept at work. \$2 per bottle delivered. Book \$ E free.  
ABSORBINE, JR., liniment for mankind. Reduces Goitre, Tumors, Wens, Painful, Knotted Varicose Veins, Ulcers. \$1.00 and \$2.00 a bottle at dealers or delivered. Book with testimonials free. W. F. YOUNG, P. D. F., 23 Temple St., Springfield, Mass.

### DEATH TO HEAVES

Heave, Cough, Distemper and Indigestion Cure.  
The first or second \$1 can cures heaves. The third is guaranteed to cure or money refunded. \$1 per can at dealers, or express prepaid. Send for booklet.

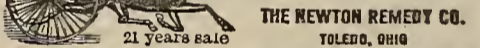

THE NEWTON REMEDY CO. TOLEDO, OHIO  
21 years sale

### FENCE Strongest Made

Made of High Carbon Double Strength Coiled Wire. Heavily Galvanized to prevent rust. Have no agents. Sell at factory prices on 30 days' free trial. Fully Guaranteed. 37 heights of farm and poultry fence. Catalog Free.  
COILED SPRING FENCE CO. Box 18 Winchester, Indiana.

### ORNAMENTAL FENCE

25 Designs—All Steel  
Handsome, cost less than wood, more durable. Don't buy a fence until you get our Free Catalogue and Special Prices.  
We can save you money.  
Kokomo Fence Machine Co. 427 North St., Kokomo, Ind.

# Ann Arbor

THE BALER FOR BUSINESS

## The Hay Press of Extra Large Capacity

Get the right hay press. The points that count are Capacity, Speed, Economy of operation, and Durability. You want the press that will bale fastest and cost least to run—that means an Ann Arbor every time.  
Bales anything baleable. 73 tons a day its record. Other sizes from 1½ tons up.

It will pay you to write at once for the Ann Arbor books and learn about the recent improvements in hay press construction that increase capacity and durability without adding a cent to the cost.

### Over 45 Styles and Sizes ANN ARBOR BALERS

Horse power, belt power, and traction operated—steel or wood frame—prices reasonable—quality the highest—all backed by positive binding guarantee.

Write for printed matter. ANN ARBOR MACHINE CO., Box 408 Ann Arbor, Mich.

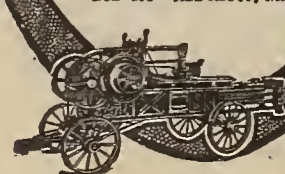

# With the Editor

SOME fifteen years ago I was associated with Mr. H. W. Campbell, the "soil-culture" man and the originator of the dry-farming movement, in the publication of an agricultural paper. We didn't stop with the advocacy of the dust mulch and subsurface packing as measures of moisture conservation, but tried to be a Country Life Commission all by ourselves. And we were ahead of the Roosevelt commission by a dozen years or so in demanding a "new kind of country school."

A man who remembers having taught as many terms of country school as I have to my credit (or discredit) is apt to have a very vivid notion of the poor work done in them after he has got out of it and can look back at it. So in *Campbell's Soil Culture* we advocated the teaching of agriculture in the rural schools.

If we got a single response from anyone except an occasional reader with no connection with schools, I don't remember it. It was ten years before I heard of any movement for such a reform in education. But now the nation is thrilling with it. If your county isn't doing anything about it, it is because there is moss on somebody's back—and further than that I won't say.

I have been greatly rejoiced to get a huge mass of letters from county superintendents lately—for FARM AND FIRESIDE is beginning to be recognized, I believe, as a great force in this movement. I'm going to talk with you about these letters to-day—because I believe them more important than reciprocity, the farmers' free list, silos, or coöperation. Anyhow, they're more important to me to-day, and the distinctive thing about this column is that we talk about the thing that seems most important to-day. To-morrow something else may loom larger—and then we'll talk about that.

IN NODAWAY COUNTY, Missouri, Mr. W. M. Oakerson is superintendent, and is vying with Jessie Field just across the Iowa line in Page County, Iowa, in domestic-science teaching and agricultural instruction. I suppose more buttonholes, hems, cakes, loaves of bread, and the like, are produced per capita by the school population in that region than anywhere else—almost. And the schools are right now in the midst of corn-growing and corn-judging contests which reach from the school-room to the furrow, and from the furrow to the capitol of the state.

"We have been teaching agriculture in all the schools of the county," says Mr. Oakerson, "for the past six years. We also do some work in domestic science, and have a contest in each every year. We distributed five hundred dollars in prizes last year, and will distribute about seven hundred dollars this year."

In Piatt County, Illinois, Supt. Charles McIntosh has had this year a very interesting potato-growing contest as a part of the school work. I hope we shall hear more of it.

Supt. Charles J. Sibley, of Calhoun County, Illinois, says, "I am doing all I can to promote the teaching of agriculture in the schools of my county. We have been pretty successful in teaching the work as outlined in the Illinois course of study." You people in some other states didn't know, did you, that in Illinois the course of study demands teaching of agriculture in the common schools? Well, you aren't much worse off than some of the teachers in the states requiring it. They don't seem to know, either. But such will give way to those who do know, in the good time coming. Calhoun County is that long tongue of land between the Illinois and Mississippi Rivers. It has never had a railway—but it teaches agriculture in the common schools. Lots of counties that have railways can't say as much.

Supt. E. T. Armstrong, of Floyd County, Iowa, has a thoroughly organized course in agriculture, and is said to be doing great work.

Supt. Meyer Brandvig, of Butte County, Nebraska, writes me, "I believe especially in rural high schools, and I am laying much stress here on practical industrial education, and on agriculture in particular."

From "the heart of the Ozarks"—Shannon County, Missouri—Supt. Walter Webb sends word that, "With the beginning of the school year elementary agriculture will be taught in every school in the county, and three high schools will maintain a laboratory course." "For the past two years," writes Lewis E. Miller, of St. Joseph County, Michigan, "I have been introducing elementary agriculture in the rural schools and some high schools of this county. The results are already apparent." The first high school of Montgomery County, Ohio, to take up the work of teaching agriculture was the Trotwood school, of which Supt. G. F. Kern writes, after seven years of experience, "Our patrons are elated at its success."

Supt. J. H. Hetley, of Day County, South Dakota, is throwing much energy into his work for the betterment of the rural schools. His work is strong along lines of crop-growing contests and exhibitions of agricultural work by public school pupils.

Prof. Lester B. Ivins, Instructor in Agriculture of Lebanon University, in Warren County, Ohio, writes:

"I have read many letters on rural school work in your paper, and have been surprised that so little was ever published concerning those problems in Ohio's schools. It has been my privilege to work along some new lines for the past ten years. I have devoted most of this time to agricultural school work. It may seem strange to you, but it is nevertheless true that Jessie Field and many other progressive school people in the West received their first inspiration from eastern men, mostly in Ohio. It is true that the western people take up these advanced movements and push them more rapidly than they do in the East. It is for this reason that many people think that these movements originate in the West when they are only eastern ideas developed. Our new law places agricultural education on a more substantial basis than in any other state by providing for expert supervision of the teaching. We have already completed the state course in agriculture for the elementary schools, and I believe it is the best yet written in any of the sixteen states that require the subject taught."

HURRAH for Ohio as the first of the great sixteen! For my part, I have always seen in Ohio the leader in rural school reform. I remember when the consolidated rural school, with its carryalls gathering up the pupils, was called "the Kingsville System of rural schools," from the Ashtabula County township that invented it. But come to think of it, we haven't said much about Ohio's great record. Well, there's the highest sanction for the policy of calling sinners, and not the righteous, to repentance. And, after all, there's plenty of room for improvement in Ohio's rural schools—and here's hoping they use all of it.

And here's hoping that this little collation of just a very few of the multitude of cases of progress in rural schools will help progress to start everywhere. It is a great age, this in which we live. Get in line with the age!

*Robert Guier*

## Index to Advertisements

	PAGE
<b>Automobiles</b>	
Willys-Overland Company.....	24
<b>Carriages and Accessories</b>	
Century Manufacturing Company.....	14
Electric Wheel Company.....	16
Empire Manufacturing Company.....	16
Harvey Spring Company.....	14
<b>Clothing, Boots and Shoes, Etc.</b>	
President Shirt Company.....	15
Steel Shoe Company.....	12
Woonsocket Rubber Company.....	16
<b>Correspondence Schools</b>	
International Ry. Correspondence In'st....	10
National Salesmen's Training Association	16
Page Davis Company.....	20
School of Illustration.....	20
<b>Farm Engines</b>	
Gray Motor Company.....	16
International Harvester Company.....	9
Leffel & Company, James.....	7
Monarch Machinery Company.....	16
Standard Scale & Supply Company.....	16
<b>Farm Tools and Implements</b>	
Aermotor Company.....	11
Common Sense Conveyor Company.....	16
Collins Plow Company.....	7
Gilles, Robert.....	8
New Process Manufacturing Company....	8
Corn King Harvester Co.....	8
<b>Fences and Fencing Materials</b>	
Coiled Spring Fence Company.....	8
Kitselman Brothers.....	6
Kokomo Fence Machine Company.....	8
Peel & Brother, J. M.....	6
Pittsburgh Steel Company.....	12
Up-To-Date Manufacturing Company....	6
<b>Fertilizers</b>	
DuPont Powder Company, E. I.....	12
German Kali Works.....	8
<b>Food-Staffs</b>	
Baker & Company, Limited, Walter.....	6
National Biscuit Company.....	12
<b>General Merchandise</b>	
Montgomery Ward & Co.....	12
<b>Hair Goods</b>	
Ayers, Anna.....	12
Parker's Hair Balsam.....	21
Vale, Violet.....	12
<b>Hay-Presses</b>	
Ann Arbor Machine Company.....	2
Ertel Company, George.....	7
Spencer, J. A.....	12
<b>Household Miscellaneous</b>	
Gold Coin Stove Company.....	21
Hazel Atlas Glass Company.....	21
Hoosier Stove Company.....	21
Ivers & Pond Piano Company.....	21
Keystone Rug Company.....	11
New Home Sewing Machine Company....	11
Schmoller & Mueller Piano Company....	6
Stewart Hartshorn Company.....	12
<b>Land</b>	
Atlantic Coast Line.....	8
Department of the Interior.....	7
Sacramento Valley Development Ass'n....	12
Seagraves, C. L. (A., T. & St. Fe Ry.)....	12
Strout, E. A.....	7
<b>Live Stock, Stock Food and Remedies</b>	
Hess & Clark.....	12
Mineral Heave Remedy Company.....	2
Newton Remedy Company.....	2
Silver Company, L. B.....	12
Young, W. F., P. D. F.....	2
<b>Paints</b>	
National Lead Company.....	8
Yuma Paint Company.....	8
<b>Patents</b>	
Evans & Company, Victor J.....	12
Farnham & Sues.....	12
<b>Publications</b>	
Harrison & Sons, J. G.....	8
Myrex Company.....	21
Woman's Home Companion.....	15
<b>Pumps</b>	
Temple Pump Company.....	12
<b>Roofing</b>	
Barber Asphalt Paving Company.....	16
Century Manufacturing Company.....	8
Edwards Manufacturing Company.....	16
<b>Separators</b>	
American Separator Company.....	16
DeLaval Separator Company.....	15
Sharples Separator Company.....	15
<b>Sporting Goods</b>	
Eastman Kodak Company.....	7
Harley-Davidson Motor Company.....	2
<b>Telephone Apparatus</b>	
American Telephone & Telegraph Co....	10

## ABOUT ADVERTISING

FARM AND FIRESIDE does not print advertisements generally known as "readers" in its editorial or news columns.

Mention FARM AND FIRESIDE when you write to our advertisers, and we guarantee you fair and square treatment. Of course we do not undertake to adjust petty differences between subscribers and honest advertisers, but if any advertiser in this paper should defraud a subscriber, we stand ready to make good the loss incurred, provided we are notified within thirty days after the transaction.

FARM AND FIRESIDE is published on the 10th and 25th of each month. Copy for advertisements should be received twenty-five days in advance of publication date. \$2.00 per agate line for both editions; \$1.00 per agate line for the eastern or western edition singly. Eight words to the line, fourteen lines to the inch. Width of columns 2 1/2 inches, length of columns two hundred lines. 5% discount for cash with order. Three lines is smallest space accepted.

# FARM AND FIRESIDE



PUBLISHED BY  
THE CROWELL PUBLISHING COMPANY  
SPRINGFIELD, OHIO  
Branch Offices: 381 Fourth Avenue, New York City; Tribune Building, Chicago, Illinois  
Copyright, 1911, by The Crowell Publishing Company  
Entered at the Post-Office at Springfield, Ohio, as Second-Class Mail Matter

## A BLUE MARK

in the square below indicates that you are an old subscriber and that your subscription expires this month. Renew by accepting one of our offers before they are withdrawn.



## SUBSCRIPTION PRICE

One Year (24 numbers) 50 cents  
Canadian, 1 Year . . . 75 cents

Subscriptions and all editorial letters should be sent to the offices at Springfield, Ohio, and letters for the Editor should be marked "Editor."  
Silver, when sent through the mails, should be carefully wrapped in cloth or strong paper so as not to wear a hole through the envelope.

Vol. XXXIV. No. 23

Springfield, Ohio, September 10, 1911

PUBLISHED  
SEMI-MONTHLY

## A Lesson in Japanese

JAPAN has no money to waste. When Japan enters upon anything new, it is because she has had the whole matter worked out and been convinced that it will pay.

Japan has no highfalutin' notions. She copies from the whole of the world the things she thinks best. We may find what seems best to the hardest headed, most practical people in the world by seeing what Japan copies from us.

Japan has about the area of Kansas, but her percentage of agricultural land is about that of New Hampshire. It doesn't look as if she would need many agricultural schools, does it? Most of her farms are so small that they would about make a stack-yard for one of us.

Yet, twenty-three years ago, according to a Japanese writer in *Hoard's Dairymen*, Japan, with only this small area of farming land, had six schools where farming was taught. And then came the twenty years of her most rapid progress. China was defeated in war, and then the mighty Russia. The whole strength of the nation was expended on those things which would enable her to carry the awful load of army, navy and bonded debt. And what, one may ask, in this time of strife became of the six agricultural schools?

Instead of being allowed to dwindle, they have multiplied, until in 1908 there were in Japan four thousand three hundred and seventy-five agricultural schools!

In these schools were enrolled one hundred and eighty-two thousand two hundred and nine pupils, and in that year—three years ago—there graduated from these schools ninety-three thousand four hundred and six graduates. Most of them were in the more than four thousand common agricultural schools scattered about the islands where almost every farm boy and girl has a chance to attend.

Japan is a military nation. She wants her soldiers to be the best possible. "Healthy, intelligent and most loyal soldiers," says this Japanese writer, "can best be found among country youths, and the most stable and reliable source of national wealth lies very near the soil. How unstable is the fate of a nation which has lost its taste for agriculture!"

How unstable indeed! But what makes the rush for the cities with us, if not just that loss? And if the wise Japanese so multiply over and over again their teaching of agriculture to the end that their youth shall not lose their taste for farming, when shall we have the wisdom to adopt that rule which Alexander Campbell laid down so long ago that agriculture should be taught in every grade from the lowest to the highest? Why cannot we be as wise in the search for national health, happiness and prosperity as is Japan, in her search for strength to carry war burdens?

## The Fall Work in Ohio

THE State of Ohio has an important bit of fall work in hand. It elects delegates to a convention which will frame a constitution for the state. It is important work. A constitution is about the biggest thing any body of men can build.

The farmers of Ohio should be active in the matter. They should see to it that a constitution is adopted which magnifies the power of just plain, common, every-day people like farmers from what it is to what it should be. They should make such corruption as that which reigned at Columbus last winter forever impossible. This they may do by pledging their delegates to the principles of the people's power movement—of which we have spoken in the past.

The corruption of legislators can be stopped by making their work always subject to the will of the people. The people's power over laws can be secured only through the initiative and referendum. No one expects that the people will ever enact any large number of laws by the initiative; but they should have the

right to legislate by vote when a legislature like that of last winter—and that was of the usual sort—refuses to act because of corruption or unfaithfulness. Farmers believe that when the hired men refuse to do a piece of work, they should have the right to do it themselves—and that is the initiative. Nobody expects that laws passed by the legislature will often be held up by having elections called on them; but when a legislature passes an act which any large portion of the people believe to be against the popular will, we should have the right to call an election on it before it becomes a law. The farmer is apt to take the position that when the hired men start to do the thing the employer does not want done he has a right to reverse the hired man's decision. And that is the referendum.

The two—the initiative and referendum taken together—constitute direct legislation.

The present system makes for machine power in the state and against the farmer's power. Direct legislation will make for farmer's power and against machine power. Farmers who favor having something to say themselves, instead of letting the "say" come from the pussy-footed cliques of the towns and villages, will probably vote only for delegates who are pledged to a constitution legalizing these measures of justice for the common every-day man as against the trained political engineers who have ruled for so long unchecked.

## Farmin' Don't Pay

"OH, I know it for a fact, sir, Farmin' don't pay. In my barn this line I've tacked, sir: 'Farmin' don't pay!' I have had the best of trainin', On the farm my bread I'm gainin', But my faith in farms is wanin'; Farmin' don't pay."

Well, I guess you're right about that; Farmin' don't pay. Seen your farm, I do not doubt that Farmin' don't pay. Drainage, culture you don't practise, Every tool you've shown me cracked is, I'll agree the honest fact is Farmin' don't pay.

Had you practised fertilization, Farmin' would pay; Drainage, moisture conservation, Farmin' would pay; Practised food elaboration, Tillage, weed-eradication, You'd declare to all the nation: "Farmin' does pay."

JOHN MALCOLM.

Iowa State College, generally known as the "Agricultural College at Ames," has established a course in agricultural education, with Prof. A. V. Storm at its head. The teachers on agriculture in the secondary schools of the nation must be trained, and Iowa's great college is getting ready to do its part in training them. And in ten years from now the greatest lack in the teaching force of the country will be of teachers for the common schools capable of teaching agriculture. By that time rural schools will be truly rural.

Tuberculosis in live stock is the same thing as consumption in human beings. There are many ways of spreading it, but the easiest way and the most common is through the droppings of diseased animals. The dust of dung gets in milk, and somebody's baby dies. It is not strange that hogs following tuberculous cattle get the disease, nor calves that suckle dams either tuberculous themselves or kept in yards where there are diseased animals. The wonder is that any escape.

## Sow Pure-Bred Wheat

SO MUCH has been said about improved breeds of corn that farmers are apt to forget that it will pay to keep open eyes as to other grains and grasses. Especially has progress been made in breeding better strains of wheat. Breeds of wheat are offered for seed which look well, but are practically worthless; and there are strains that are better in yield and quality than the common strains. Turkey Red of many varieties is the sort to sow in the Southwest and West. There are varieties of winter wheat which do well in most of the Middle West where spring wheat is still mistakenly sown. If you are still sowing the old sort, east or west, it will pay you to write a letter to your state experiment station—any county officer or banker can tell you where to send the letter—telling just what sort of land you have and where it is located, and ask the experiment station men what variety of wheat they recommend for your use. You will get a courteous answer and one that will make you money if you grow wheat.

The best place in the world to be poor is in the country. There you scarcely notice it.

If we would cultivate the crop of contentment a little more assiduously, all our other crops would be more satisfactory.

Now that our population is growing at a rate that insures a permanent and increasing demand for wheat at relatively high prices, it will pay better than ever before to use pedigreed seed.

## Shrinkage of Corn

IN THESE observations on the time to sell corn, we have seen that year by year the price is from fifteen to thirty per cent. higher in midsummer than in midwinter. Extremes both ways are not taken into account. On the whole, if we look at the price per bushel only, it will pay to borrow money at six or even eight per cent. for the purpose of carrying corn over to midsummer rather than to sell it in January. But there are other things than price to look at. Experiments show that corn shrinks in weight as it grows older. It loses moisture. It is not safe to reckon this loss at more than seven per cent. Thus if we pay three per cent. interest for six months, and lose seven per cent. in weight, we must get ten per cent. more per bushel for the corn than we could have obtained in January, or we shall not have made anything. And this allows nothing for spoilage and rattle in bad cribs.

Some men in Illinois tell us that ear corn will, on the average, lose eighteen per cent. from November to July. In place of 1,000 bushels, on December 1st, on July 1st the farmer has 820 bushels. The greatest shrinkage comes in May and June. The following figures are interesting. They are calculated for 1,000 bushels at January 1st, and show actual gain or loss by holding corn till midsummer.

Year	January Price	June and July Price	Sale of January 1st	Sale of July 1st	Loss or gain by holding
1906	\$.40	\$.55	\$400.00	\$451.00	Gain \$51.00
1907	.45	.57	450.00	465.00	Gain 15.00
1908	.60	.80	600.00	655.00	Gain 55.00
1909	.60	.77	600.00	630.00	Gain 30.00
1910	.67	.66	670.00	540.00	Loss 130.00
1911	.50	.60	500.00	490.00	Loss 10.00

Because of the fact that there is little likelihood of markets going down as they did in 1910 and 1911, the holding of the corn would seem to be the proper thing for the man with capital and good cribs. In this connection, it is well to bear in mind that corn weighs out better during or after a moist-weather period.

# Give Us the Big School

Thousands of teachers over the land are asking for the big school. The needs of thousands of country districts are silently sending up the same plea. The remarks which follow are no more fervent than the remarks of many a teacher who is almost disheartened by day after day of unsatisfactory work. There are some teachers who are teaching wholly for the salary received, but they are few. The fact that should be uppermost is that so many children in our rural districts are neglected. The blame can seldom be placed on the teachers. It more frequently falls at the feet of citizens who do not see the progress of the age. Give us the Big School!

## An Equal Chance for All

By Meta R. Bachmann

WITH several years' experience as a teacher in rural schools, I believe that I have a full appreciation of the consolidated rural school.

My work one winter was in one of those kind of schools (and, alas, there are many more just like it) where everything is, was, and will be for a long time in the future, overcrowded to the bursting-point. I had pupils ranging from the beginners to the tenth grade. Each recitation period was of ten minutes' duration only. How often I had to keep my older pupils in while the younger ones had their recess, and vice versa. Many times I had to keep two or three spelling classes after

sufficient time each day in all their studies so that the winter's work would stand out in bold relief; but I had to rush, rush and my successor did the same, only she was with them two winters.

How often I wished for another teacher in that school-room! How true and thorough our united efforts would have been! How much lasting good those young lives would have gotten had they had more time for recitations!

I noted with a sinking heart that in so many places the teacher is not supposed to be alone the instructor; she must needs be minister, missionary, doctor, mother, maid, janitor and also music-teacher. She is to look sharp to the morals and manners of her flock; she is expected to teach domestic science, farming, stock-raising, lumbering and mining, and she, foolish maid, meekly bows her head and murmurs, "Be it so."

Do not misunderstand me. I believe that a thorough teacher should have a knowledge of all things expected of her, but she must have the time to aptly apply and instruct what is expected. If the public wants music, domestic science and manual training, let them hire special instructors as they do in some cities, or go without.

I have in mind two consolidated rural schools of western Washington. There they do not hire the young, inexperienced teacher, who, bless her, must have a start somewhere, but they take teachers with a long experience and a normal training. Teachers who come to them highly recommended and who can show that they know what they are about. The principal in one of those schools is a former county superintendent from an eastern state, the primary teacher is a woman of long experience in school-room work and one with a good normal training.

Both these Big Schools are successes. The surrounding farm neighborhood is loud in praise of the excellent work done by their teachers. The children are happy and learn well. And why is this all so? Very simple, indeed. The patrons of the school are wide-awake farmers who think nothing too good for their youngsters. They are proud of their children, proud of their schools, proud of their teachers; they are awake to the times, and truly it is a joy to live among them, for nothing is too expensive when it comes to the education of their children.

But even in those two schools they need three teachers for the common branches where they now have but two. I fully believe that the farmers will hire the third teacher in a year or two, for their schools do as good work as any done by city schools in Washington.

The Big School, where I have seen it, is a success. I am thankful that each year increases their numbers.

Now, do we need the Big School in our community? Let us look close. Let us watch and pray that we neglect not the jewels of the nation. Let us give to our children that which we could not have. Let us give them the Big School with all its grand possibilities.

## Consolidate the Rural Schools

NOTHING we have ever published has gone more deeply into the hearts of our best readers than the articles by Miss Field and others on rural education. No letters of inquiry are more frequently sent to the editors than those asking about some phase of rural education. It is not surprising how widespread this interest is, for the country people are beginning to realize that their children need the same advantages as city boys and girls enjoy. These same parents feel that the securing of the advantages is possible. A reader in Missouri voices the sentiments of many in the following letter:

Why cannot we have better rural schools? Here in my neighborhood the farmers are all well-to-do, yet in one little town we have the same old school-building, the same old school-yard and the same old methods that were in use years ago. One progressive young teacher who had charge of the school a few years ago did labor hard to have a year of high-school work, and did succeed in teaching a high-school class in connection with the grades, but when he left our school for a better one, we fell back to the same old routine. What we need here, and I believe in most rural districts, is the centralized school. Why can't we agitate this question? Now we have to send our children away to school as soon as they have finished the eighth grade. If we could centralize, we could have the central school in our town, which is in the exact geographical center of the township, and we could have ample funds for a splendid grade and high school. That applies to our Missouri conditions and it applies elsewhere.

This reader wants high-school training for her children—and every American boy and girl is entitled to that much of an education in this twentieth century. But rural schools need rural studies and the rural viewpoint in the books used and the studies prosecuted. We need not only better schools, but schools different from the best town schools. They must be rural schools.

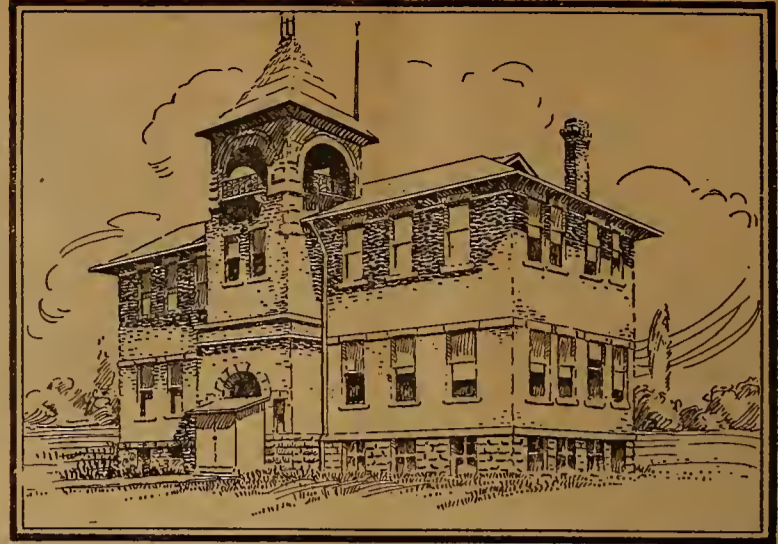

The Big School is not like the city school. It is a better rural school. That explains why it is successful in all of the states

## The School Dry-Rot

By Mrs. F. W. Nisewanger

IN OUR State of Iowa there is a whole lot of misplaced sentiment displayed in connection with our little district schools. Probably other states are affected the same way. In the process of educational evolution these district schools had a place—and an important one. Now they should resign gracefully in favor of the consolidated graded rural school system that has proved successful in so many states, and parts of states.

A farm paper came to my hands a few weeks ago, containing a picture of a neat, little, one-room country schoolhouse that illustrated a touching poem whose burden was the hungry longing for the close of vacation and the return of the music of the old bell and the shout of childish voices. The poem should appeal particularly to those districts (and there are many) that have vacation all or a large part of the year, either because there are not enough pupils to warrant having school, or there is no competent teacher (there are not nearly enough to go around).

Another farm publication came to-day, picturing seventeen bright-faced country children ranging in age from a dear five-year-old baby to a girl of sixteen or seventeen years, backed by a little schoolhouse lighted by four windows. Below this picture was this: "The country schoolhouse and the young folks upon whom our future depends."

And right there is the point. Both rural and town people are ready enough to say that the future of the state and nation depends largely upon the country children of to-day, and yet we handicap them educationally by supplying them with instruction given by a second or third grade teacher who knows very little, and cares much less, about rural conditions and needs. And who, however willing and earnest, is unable to

do her best because she must oversee six or eight grades of work in the same length of time that a graded-school teacher gives to two or three.

A secretary of a school board announced publicly: "I know rural schools are not what they should be, and if anyone can devise a plan by which we can secure better teachers, I'll give my hearty cooperation; but as for consolidation, I will oppose it."

Similar statements are made by county superintendents and other officials to hinder the good work. This makes all effort along these lines difficult.

What is true of Iowa is true of many of her sister states, as a rather extended knowledge of rural school conditions proves. I suspect that the effective agitation that leads to reform must start among farmer-parents.

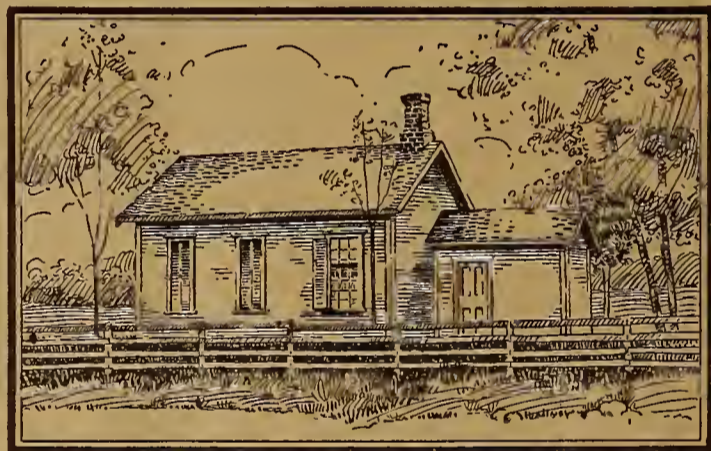

Efficient in its day, but that day is past

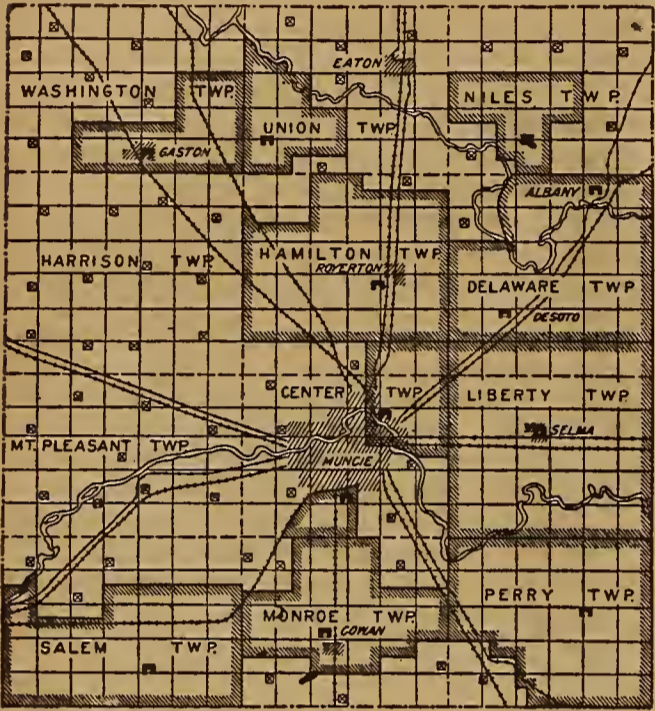

Delaware County, Indiana, where consolidation exists in about fifty per cent. of the area of the county. About 1,300 pupils are daily transported to and from the schools

the hour of dismissal in order to finish the day's work, and what a howl went up from the various parents because I dared to keep school after school hours.

I worked early and late. It was often six o'clock before I left my schoolhouse weary in body and soul at the incompleteness of the day's achievements. Seventy-three in the morning nearly always found me back in the school-room, and besides this, I worked till the hour of eleven nearly every night, correcting papers, looking up new work, and the like. I lay awake nights wearying my brain trying to solve the problem just how I could give more of myself to my pupils. I wanted them to do full justice to all their studies. I wanted high standing; I wanted thorough understanding on their part. I did not want them to grope blindly. Thoroughness was my watchword day and night, and when I got back to work in the morning, the same trials of yesterday confronted me. How could I explain, teach and analyze a full lesson in ten minutes? The parents expected all their children to make their grades, and I, foolish and blinded by my zeal, tried to force them (my pupils) into that which they should have done with a will.

My venerable school board insisted that I keep the younger children as long as the older ones. Often one or the other of my older girls could have helped me with the smaller pupils, but my school board told me that they had hired me, and I had to do the work or quit. They could never get it into their heads that all the work of which those youngsters were capable I could do in two hours' concentrated and thorough work in the mornings, and have the rest of the day for the older pupils.

For a wonder, most of the pupils loved their work, but it hurts me to this day that I could not give them

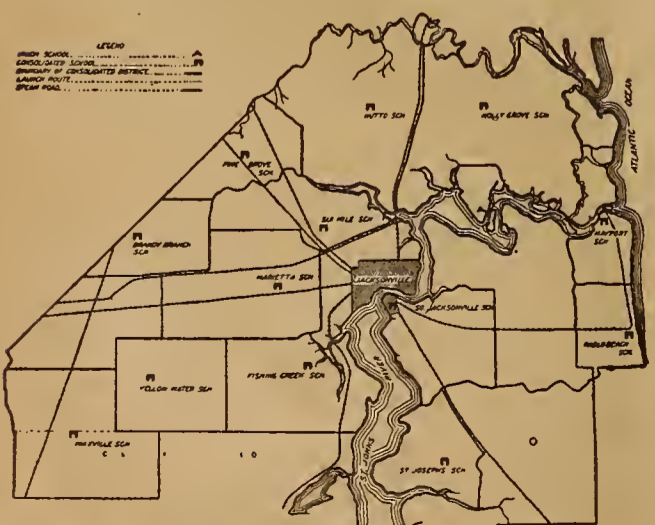

Duval County, Florida. Area, 884 square miles. Launches assist in transporting the children. Each county presents its own problems, but they may be overcome if there is really a desire to better the conditions

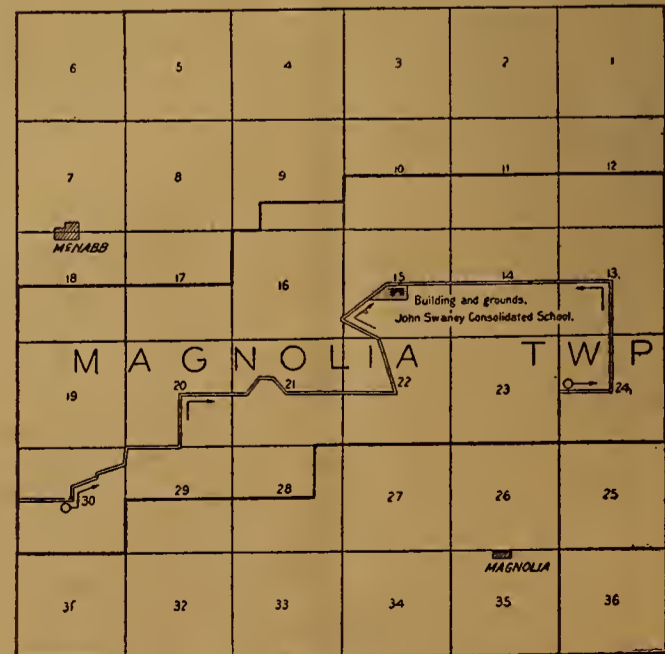

One township in Putnam County, Illinois. Area of district fourteen and one-eighth square miles. The arrows indicate the route of the school wagons, which carry twenty-four and thirty pupils respectively

# A Winning Fight for Fertility

By David Buffum



**T**HE great majority of farms that are offered for sale, at least in all the older states, are in a more or less run-down condition. Thus the purchaser, besides having to pay for the place, has to incur the additional expense of putting the buildings and fences in repair and restoring the fertility of the soil. He may, it is true, buy low enough to offset these expenses. Most assuredly he should. But, in any case, the undertaking requires both thought and effort and often involves more

expense than was at first counted on.

For this reason I am prompted to tell some of the methods my sons and I have used in building up a run-down farm—not that there is anything very unique about our work, or that our success has been in any way phenomenal, but simply because we have found our methods good ones and they may be of some help to others who have the same task in hand.

Our finding of the farm was largely a matter of accident. Cruising one day in Narragansett Bay, we ran our sloop for the night into a little cove that forms the harbor of Prudence Island. The following morning, the green shores presenting an unusually attractive appearance, we went ashore.

Most of the island is rather hilly, and we found its fields, which in colonial days raised large crops, overgrown with blackberry-vines and bay-bushes, but, approaching a part of it known as "The Neck," a surprise met us. Here the island narrowed and flattened, and a beautiful plain, unbroken by rock or bush or tree, and covered all over with the feathery bent-grass for which the island was once famous, stretched from shore to shore. The grass, it is true, was short, but its presence after the deadly farm-skinning, which had so exhausted the fertility of the island, indicated a rather better quality of soil than that of the higher portions.

In the distance was a group of abandoned buildings, unpainted, their shingles blackened by the salt air, and to them we bent our steps. There was a roomy three-story dwelling and, close by, a smaller house, evidently intended for the foreman and hired help, also a granary, poultry-houses and two barns. All were in wretched condition, but we stood on the dilapidated piazza of the house, looked out over the broad, green plain with its setting of bush-grown hills and beyond it the blue water of the bay, and decided that we wanted it.

We bought the property a little later and I wish I could make my story better by saying that we bought it low. But this we did not, for, unlike the abandoned farms of the back-country, these water-front properties are held at a figure commensurate with their supposed value as building-sites. We have since sold some of it for that purpose, but we bought it for farming and for nothing else.

The first thing to do, of course, was to repair the buildings, a job that cost us in all about fifteen hundred dollars. As much again could have been spent to advantage, but I never believed in putting into agriculture, or any other business, too much money till it had first been shown that it would pay. If buildings can be made weather-tight, they will usually answer their purpose even if lacking in conveniences.

## Barn-Yard Manure Was Expensive

In the question of how to best build up the land, it seemed to me this could not be done by buying manure. For stable manure, delivered here, costs a prohibitive price, and commercial fertilizer, according to my experience, would not answer the purpose. I had often found it useful for putting in the hill, for it furnishes a plant-food that is almost immediately available and so gives a crop a good start. But I could never observe that it was of any material value in building up the soil or even in maintaining it on an even basis, if crops are planted every year.

In Portsmouth, Rhode Island, a very fertile section, where many acres are annually planted in potatoes, it used to be the practice to manure the ground rather heavily with stable manure, spread broadcast and plowed in, and then to use about half a ton of commercial fertilizer in the hills. This was gradually superseded by the practice of using no stable manure whatever and using a full ton of fertilizer in the hills. This enormous quantity is now becoming insufficient, a little more being needed each year. No better proof could be had, I think, that a fertilizer highly concentrated, but lacking in bulk, is rarely sufficient for soil-building and that, as a rule, a more bulky manure, furnishing humus, is what is required.

It is true that commercial fertilizer can be used for the growing of crops to be turned under green, and to furnish the needful material. But our land was already producing a certain amount of hay which was fed to live stock, and it seemed to me that the money which the fertilizer would cost could be more advantageously used in the purchase of grain to feed along with the hay.

We proceeded to put these conclusions into practice. Large quantities of seaweed were frequently washed up on our beach and a large acreage of marsh gave as many tons of salt hay. We worked these substances into manure by using them as litter. Accordingly we bought cows, calculating as closely as we could the number our hay would feed, and used under them, and also in the manure-pit, as much litter as we could. There remained, even so, a large amount of marsh hay. We tried the experiment of spreading it on the land just as it was and plowing it in, but we were not satisfied

with the result. So the next season we baled and sold all we could not use. This was more satisfactory.

The manure that our cows made was applied by spreading upon greensward—always giving it a heavy coat—and then plowing in and planting to corn. We have adopted the plan of husking early and getting all the corn and stover off the ground before the first of November, which enables us to sow the ground with winter rye. The earliness of our corn, called Rhode Island Capped, which matures in about ninety days from time of planting, enables us to do this easily. The rye we grow solely for the straw; we cut it when the grain is in the milk and sell without thrashing. Rye-straw, tied in bundles and nicely baled, sells at Newport for twenty to twenty-eight dollars per ton, the price varying from year to year.

We sow grass-seed with the rye, supplemented by another sowing in the spring, and have had fair luck in getting a catch this way. But it must be remembered that in this salt air we rarely have much winter until Christmas. In colder localities this method could not be followed. We make it a rule never to plow a single foot of land that is not manured very heavily, a rule that I earnestly recommend to all who are building up run-down farms.

## Make the Farm Pay Good Returns

You need have no fear of plowing in too much manure. All tilled crops are expensive to raise, and if your crop is not a heavy one, there will be little or no profit. The labor, a heavy item in any event, will cost very nearly as much in a light crop as a heavy one. The one great secret in getting up a run-down farm is to build it up and still get something back as one goes along. With manure spread as it very often is, this end is not gained, for there is not enough left in the soil after the crop is taken off. The photograph which heads these columns was taken in our rye-field last summer. It shows rye grown on land from which a heavy crop of corn had previously been taken. It stood six feet high on the average, many stalks being nearly seven, and the same land with no additional manure now shows a fine stand of grass and clover.

Meanwhile, we have used only our coarse manure in the way I have indicated. All the droppings from the hen-houses and other manure that was fine enough have been used for top-dressing our mowing land. This might not be the wisest course in all localities, but it seldom happens that any two different localities, even though apparently similar, call for exactly the same treatment.

Such local peculiarities are matters a farmer should study. On these islands of Narragansett Bay bent-grass, which somewhat resembles redtop in appearance, but is much finer, shorter and makes a sweeter hay, finds its natural home. Do nothing to the land and it will produce bent and nothing but bent, as long as it retains sufficient fertility. Bent, however, needs manure to



The old system of spreading fertility to soils that need it. Much credit is due this system for the good it has done in building up farms everywhere. It is still of value

produce a really good crop. The fact that we have a grass so well established has made us feel that it is of little use to disturb any land that we can maintain by top-dressing, and we plow only as much land as is necessary for the best utilization of our coarse manure.

I do not propose to dwell very much on our own drawbacks, but the reader may be assured that we have them. Tree-growing, for instance, is no easy matter in a situation so exposed to sea-winds. Keeping cows, too, has proved a temporary expedient, to be discontinued as soon as our fences and buildings were in readiness for sheep and horses; and this change we have already begun. Here again is one of those local conditions that a good farmer must consider, for on this island, where it is always difficult to secure good help, dairying is not a profitable business, while just across the few miles of salt water that separate us from the mainland most farmers for their income depend mainly upon cows.

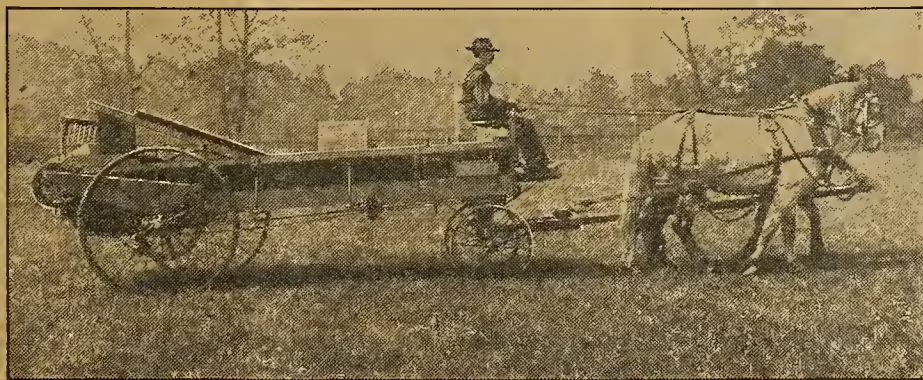

But the modern manure-spreader makes possible the same results with less labor in less time, and so is a money-saver. The manure is applied to the land just as it is needed—evenly

In a previous issue of FARM AND FIRESIDE I described another important department of our farm, the poultry. Our books during the past five years show an annual profit of \$1.11 to \$1.35 per hen.

The question I am sure the reader will want to ask is, "Does the farm pay?" Yes, it does pay, not a phenomenal profit, but as much as any man who has some knowledge of farming could reasonably expect, and perhaps rather more, for in most of the farming matter that we have now in hand we have made little more than a beginning. And this is one of the advantages of taking up a farm, new or old: Once it is put upon a paying basis, there is always the opportunity to enlarge.

I would call the attention of all who may be thinking of buying run-down or abandoned farms to three points in the one we selected. First, it was covered with grass, which is a very different thing from rocks and bushes; second, it had to some extent a source of fertility of its own, the seaweed; third, the large acreage of salt-



Wasted fertility. Too much manure on the flanks of the cows and in the barn-yards

marsh was in shape to yield an immediate crop, without tillage or manuring that could be used on the farm or sold. I believe that a man can succeed without a natural supply of fertilizer, for our supply of seaweed is uncertain, some years amounting to very little. But to buy a farm that is yielding absolutely nothing is a pretty heavy handicap, and I would certainly caution all against buying land that has to be cleared of rocks and bushes.

I have seen such land advantageously utilized for fruit-trees, but as a rule it is only the reasonably smooth tillage land that promises good returns for soil-building.

## For a Run-Down Farm

**N**O LAND that is of a good mechanical make-up and was formerly fertile can ever be entirely worn out. Nature stops the process and locks up what she has left till someone is wise enough to restore the organic decay that formerly made it a virgin soil. All over the South we see how nature has restored what man has wasted. An old field is thought to be worn out. At once nature covers its nakedness with broomsedge, and among the sedge the pine seed are blown below the scratch plowing of the past, and mineral matters are pumped up, allowing the trees to scatter dead leaves over the ground. After a series of years someone clears up the pines and finds a piece of new and fertile soil, and no fertilizer man had anything to do with it.

Now it takes nature a long time to accomplish this, but it shows us the way, and we can do the same thing in a far more speedy and economical way. We have a team of plants, one for summer and one for winter that are doing more to renovate the soil than any others. These are the cow-pea in summer and the crimson clover in winter. Often it is best to start a regular four-year rotation of crops on your four fields.

Of course, at the start it will be necessary to plant the crops of the rotation without regard to what has been on the land before. For much of the southern lands, Kentucky in particular, I would suggest corn, with peas planted in it at last working. Cut the corn off at the ground when mature and cure it in shocks. Then disk the pea-vines down well and drill in winter oats in September, giving them a dressing of acid phosphate. Cut the oats when in the dough stage for hay rather than pasture them, and at once sow peas on the land at the rate of a bushel an acre. Mow these for hay when the pods turn yellow, and then put the stubble in fine order with the disk-harrow, and drill to wheat. Next spring sow red clover on the wheat.

Run this clover one season for hay or pasture and in the fall get out all the manure you make during the fall and winter on this clover and turn under for corn again. Or, instead of sowing the red clover, follow the stubble and sow wheat again, and follow that wheat with the annual crimson clover in September, and on this put the manure during the winter and turn all under for corn in the spring. If a systematic rotation is followed, land will rapidly improve. There should always be some green crop on it in winter to save the loss of plant-food by the winter rains.

W. F. MASSEY.

**EDITOR'S NOTE**—How to keep the fertility of the soil up to standard, and at the same time to secure large returns for the labor expended, is one of the biggest problems of the American farm. Newly discovered facts are helping to solve the problem of fertility; but they are helping no farmer who will not use them. Again there are those men who so emphasize the fertility needs of the farms that everything else is given an unimportant place. And in such zeal some of the best of practices may be overdone. The use of the manure-spreader is certainly to be advised, but it may introduce evils not at all small in their effect on the net returns from the farm. Of this and other problems FARM AND FIRESIDE will have much to say.

## It's Baker's and It's Delicious



Made by a perfect mechanical process from high grade cocoa beans, scientifically blended, it is of the finest quality, full strength and absolutely pure and healthful.

Sold in 1/5 lb., 1/4 lb., 1/2 lb. and 1 lb. cans, net weight

Booklet of Choice Recipes  
Sent Free

**Walter Baker & Co. Ltd.**

Established 1780 Dorchester, Mass.

## 50 Beautiful Post-Cards

Assorted Subjects for  
Farm and Fireside Readers

We have just concluded another purchase of Post-Cards which enables us to offer our friends an assortment of fifty cards of the very best quality and design, absolutely without cost.

These cards are without doubt the acme of post-card production. They are lithographed in ten colors and the designs are new, original and attractive.

### You Will Want These Cards

And we want you to have them. The subjects are many and varied, and can be applied to all occasions, such as Birthday Greetings, Best Wishes, Good Luck, etc.

We give you our positive assurance that a finer assortment of Post-Cards cannot be obtained anywhere. These cards are the best in every particular.

### Write To-day for Particulars

We will reply immediately telling you how you may obtain this fine assortment of high-colored, high-finished, high-priced Post-Cards without a cent of cost to you. Write at once. Address

**FARM AND FIRESIDE**

Post-Card Department Springfield, Ohio

## P. & B. Fence Anchors

Keep hogs from going under wire fence. Hold fence down in crossing depressions. Protect stock from lightning by forming ground connection. Hold in any soil. By their use you can set your

**Posts 35-40 Ft. Apart**

Saving half the expense and labor of posts. Simple, cheap, easy to use. No digging. Special driving tool free with orders for 100.

Ask your dealer or write us today for a copy of our illustrated Booklet FREE. We are making \$5.00 a day and up. Good territory open. Send 6c stamps for sample and terms.

**AGENTS**  
J. M. PEEL & BRO., Box 305, Marysville, Ohio

## KITSELMAN FENCE

Get It From the Factory Direct

Sold direct to you at factory prices on 30 days trial. Save the dealers profit. Farm, Hog and Poultry Fence at from **11 1/2 CENTS A ROD UP.** All wires are heavily galvanized 80 rod spool of ideal galvanized Barbed Wire \$1.55. Write to-day for large free Catalogue showing 75 different styles and heights of fencing.

Box 271

KITSELMAN BROS. MUNCIE, IND.

**Cheap as Wood.**



We manufacture Lawn and Farm Fence. Sell direct shipping to users only, at manufacturers' prices. No agents. Our catalog is free. Write for it today. UP-TO-DATE MFG. CO., 971 10th St., Terre Haute, Ind.

## Farm Notes

### Filling the Silo

**T**HE filling of the silo is a simple operation, when one has the necessary help, machinery and the jolly good will of the helpers. Hard work is always made easy when there is more or less good-natured bantering going on among the boys. Filling a silo takes hard, muscular work and lots of it, but it takes lots of hard work to gather a corn crop, anyhow. When it is put into a silo, it is gathered in the best way of all. It will give the most returns for the crop.

There are several makes of silo-fillers. They are all made to work, and any of them will do the work when properly run. The main thing in operating the silo-filler or silage-cutter is to keep the knives sharp, so they will make a clean cut at every revolution, and to keep the loose stalks and trash picked up and fed into the cutter after every load so that there is no great pile of trash to be bothering. The man doing the feeding should feed the stalks in just as fast as the machine will take them, so as not to be losing any time. It costs money to have a silo-filling crew all losing time and the main rate of filling depends on the man feeding the machine. We have always worked one man at the job half of the forenoon and then had him trade with one of the men hauling bundles the balance of the forenoon; doing the same in the afternoon. This always keeps a fresh man at the feeding-table. It is hard, active work to feed fast and properly. When possible, the corn should be fed in tassel-end first. The machine takes it better that way. The pitchers can greatly help the feeder by pitching the bundles right end to, and pitching them at a steady, regular rate. We always have our corn in bundles, but that fact does not make the operations on our place particularly different from those elsewhere.

### The Power

About the most efficient power is a twelve to fifteen horsepower steam-engine such as is used in small thrashing rigs. Although good gasolene engines do good work, I prefer the steam-engine, for it gives the more steady speed and is much less easily stalled in case of the cutter getting too much corn. A young man in our neighborhood has an engine which he uses altogether for the silo-filling, and he charges twenty dollars a day for himself, his engine and water-boy.

The cutter should be placed as close to the silo as possible and securely staked down and braced to overcome the pull of the belt from the engine. When the cutter is in position and staked and braced, then put on the blow-pipe. The straighter up it can be put, the better it will work. We put out blow-pipe (which is in four sections) together as we raise it. We tie a rope to the hood on the top section and have a man at the top of the silo to steady the pipe while it is raised from below till the next section can be joined and clamped on. Then we raise it again for the next section, and so on till all four sections are on; then we raise all four and place the bottom of the blow-pipe in place on the cutter.

We set the cutter to cut the stalks in chunks one-half inch to an inch in length. We try always to keep the knives sharp enough to cut the husks of the ears. When the knives begin to get dull the husks will begin to be blown up uncut, although the stalks and ears will be cut all right.

### In the Silo

The man or men in the silo have a responsible place and a hard place to work, too. As the cut corn drops from the hood of the blower, all the heavier parts drop nearly directly down and soon form a pile there if not thrown to the outside with a fork. The lighter leaves and the husks blow to the outside wall, and if no one is in the silo to keep the cut corn properly scattered, the silo will fill very unevenly and settle unevenly and cause more or less moldy silage. The ideal way to have the cut corn in the silo is to have it all evenly distributed, lowest in the center and highest around the edge. The men should aim to keep the top of the silage in the silo the shape of a deep saucer, the center always the lowest, but it is hard to do so when everything is working well below around the engine and cutter and there are no stops.

The crew necessary to fill the silo consists of five men and teams and racks if the corn-field is near to the silo, but more men and teams are needed if the haul is any distance; a man to feed the cutter; one or, better, two men in the silo; the engineer and the water-boy, and a man with a good four-horse team on the corn-binder. The binder should have had at least three hours' start of the crew, for if it has not had, and everything works right, the crew will catch it before the silo is filled unless the corn is exceedingly thick.

I think the best corn for silage is that which is well-eared, so that there is plenty

of grain in the silage. The best time to cut the corn for the silo is after the kernels have dented and yet before the leaves are dried. During a normal fall this period of the corn lasts about ten days. If the corn is cut too green, it makes a sour and very acid silage, which is not very palatable for the stock. If the corn is cut too late and put into the silo too dry, portions of it will dry mold or, as we sometimes say, fire. Last year we had to wait a little too long for the engine, and the frost caught our standing corn, but we wanted to have our silo full anyhow, so I hired two water-wagons and kept a constant stream of water an inch and a half in diameter running into the blower with the cut corn. The water was thus blown up with the cut corn and it went into the silo dripping wet. This was an experiment with us, but it worked fine, for the silage came out all winter sweet and good, and I am sure it would have fired had not the water been constantly mixed with the cut corn.

After the silage has been in the silo a few days, it gets hot and some acid is formed which kills all the germs in the silage. The first foot or so on top will spoil and decay and form an air-tight cover for that below. The silo is air-tight itself so no more germs can get into it, and the silage will stay in it for several years without spoiling or drying out. If one has a stave silo with iron bands, the bands will have to be watched very closely, for the settling of the moist silage swells the staves and causes great pressure on the bands. If the bands are too tight and are not loosened, they will burst the fourth day after filling. The three lower hoops need the most careful watching, for they are the ones that have the greatest pressure to withstand. PAUL H. BROWN.

### Two-Wheel Fodder-Rack

**H**ERE is a rack that I use for hauling corn-fodder, straw and many other things. Only two wheels are used. These may be mower-wheels. They should be about one foot back of the center of the rack, so that the front end will stay down on runners. Bore a hole through the two-by-eight side-



pieces for axle. To keep fodder from resting on wheels, make two simple wheel-houses as illustrated.

This rack is low down and one man can load it easier than two can a high-wheeled wagon. It is easy to pull, since the horses are hitched low and take weight off runners. I have used mine for years and would not be without it. For ordinary use no tongue is necessary, though it would be required if the rack were used on icy or steep hills.

CHAS. ALBERDING.

### Wooden Hydraulic Ram

**S**OME think that it takes a man who has had a course in hydraulics to put a hydraulic ram in operation, but I think that is a mistaken idea. I have never taken a course and have seen but one ram besides my own at work, yet I have a ram which has been on duty about fifteen months, day and night, Sundays not excepted. Further than this, it was made out of wood, and on my own place. This is the way it was made.

I took a block of hard wood ten by twelve by thirty inches. A one-and-three-fourths-inch hole was bored from A to O, then from S to O, connected to A O at an angle. I mortised from M to A O a hole four and one-half inches at the top as shown at V.

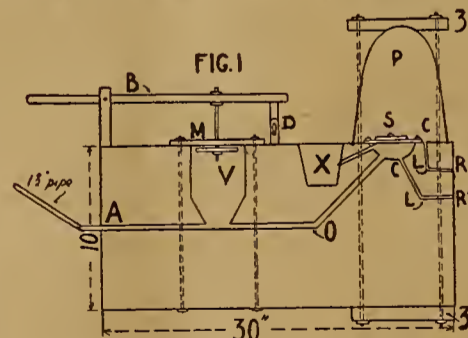

A saucer-shaped hole was cut out at S as shown in sketch. A lever (Fig. 2) was made and pivoted at B. In a plate of iron three-sixteenths inch thick a hole was cut (Fig. 4). This was bolted down at M, using common bolts. A piece of sole-leather was placed under it to answer for packing and also to deaden the stroke of the valve. A hole was cut in the leather the size of the hole in the plate.

Fig. 3 was suspended in mortise V (Fig. 1). Into a plate of iron (Fig. 6) eight five-eighths-inch holes were drilled in a small circle. This was bolted down with lag screws over mortise at S. The leather valve (Fig. 5) was fastened over holes (Fig. 6) with a small bolt through center hole in plate and in valve, and fitted water-tight at the bolt. Packing was placed under the plate and all screwed down tight. At X a cut was made of sufficient depth and width to allow an air-tube to be inserted in a hole bored with a bit at a slight angle upward.



### Buy this Piano at a Special Price

You may do that if you act promptly. Our RESIDENT FACTORY REPRESENTATIVE OFFER is being eagerly accepted by many music lovers daily. Orders are coming in rapidly for Schmolter & Mueller Pianos, accompanied by applications for REPRESENTATIVESHIPS. A limited number of REPRESENTATIVES may yet be appointed. Regularly our customers save from \$100.00 to \$200.00 in buying Schmolter & Mueller Pianos—under our REPRESENTATIVE OFFER an Extra Saving is made possible. Post yourself about this proposition, and about the

### Schmolter & Mueller Piano

By hurrying to us your Coupon to-day. Nothing to be gained by delaying—much to be lost. Money saved—Special terms to be yours—a Satisfactory piano for your very own—these are some of the advantages you may have by mailing the coupon back to us this very day. Act—ask for Catalog—Prices and Proposition—these you'll receive, and promptly.

**Schmolter & Mueller Piano Co.**

Dept. J. F. F. 99 - - - Omaha, Neb.

Schmolter & Mueller Piano Co.,  
Dept. J. F. F. 99, Omaha, Neb.

Send me Catalog, Prices and Terms on the Sweet Toned Schmolter & Mueller Piano.

Name.....

Address.....

## Music Lessons Self-Taught

### Neither Teacher nor Money Required

**A**FTER six long years of patient experimenting upon the part of the inventor, there has been perfected the most wonderful method ever devised for the self-teaching of music. With this work in their possession, anyone can learn in a short time how to play an accompaniment in any key on the organ or piano!

Owing to the unique arrangement of the method, one does not need to know one note from the other, nor have to spend a lot of time in study before being prepared to play. On the contrary, you learn to play at once and at the same time you get a fundamental knowledge of the theory of music.

### This Marvelous System

consists of twelve lessons in chart form, which simplify the study of music to a remarkable degree. The charts show a series of chords in all keys. The method of using the charts is very simple. You merely place the chart above the piano or organ keys, as directed, and you can produce perfect harmony almost at once.

Grove's Music Simplifier has been endorsed by the world's greatest musicians, including Josef Hofmann, the world-renowned pianist; Dr. Horatio W. Parker, Theorist of Music, Yale University; Mr. George E. Whiting of the Boston Conservatory of Music; Dr. Hugh A. Clarke, Professor of Music, University of Pennsylvania, and scores of other famous instructors.

### No Knowledge Required

You may not know the slightest thing about music, but that makes no difference. In an almost incredibly short time you can learn to play an accompaniment to your own melodies and to the songs of your friends. If you have never played a note in your life; if you love music but hitherto have been unable to give it expression, this wonderful book will open up for you a new world of pleasure.

The Music Simplifier is not for sale at any price, but we will give you a copy without cost in return for a few minutes of your spare time. Send to-day for descriptive circular which contains the first lesson complete. It's free. At the same time we will tell you how easy it will be to secure the book itself without costing you one cent. Address

Department M

**THE CROWELL PUBLISHING COMPANY**

Springfield, Ohio

This air-tube was made of a small piece of pipe, plugged at one end with lead, with a very small hole placed in the plugging. At S was cut a circular groove to receive the air-chamber, which was an old stove-pot. (The pot was not exactly what I wanted, but was the best thing I had.) A strip of packing was put in the groove and the pot placed

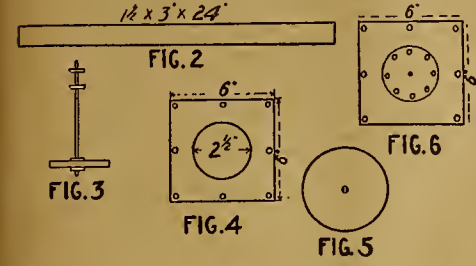

and bolted down. The timbers at 3 3 were placed at right angles to the body of the ram, the top one being hollowed out to fit the inverted pot.

The pot was fastened down with four long bolts that went through the timbers above and below. A three-fourths-inch hole was bored downward and outward as shown at C C and R R', being connected at L L. The piping was well threaded and screwed directly into the holes in the timber to sufficient depth to insure a good hold. After all these things were done the ram worked successfully.

In this particular case water enters the ram through A from a dam ten feet higher than the position of the ram. The brace D prevents the valve from lowering too far. R' comes from a spring which likewise supplies water to S. A check valve prevents the water from being forced back into the spring. The delivery pipe R, which leads to the house six hundred feet away, is made of three-quarters-inch pipe. C. M. GRAVELY.

**Some Silo Cautions**

I know a farmer who thought a cement-block silo required no reinforcement. When the silo cracked, he blamed the masons, and the masons said he did not give the mortar time enough to set. All this trouble was caused in an attempt to save the price of a little wire which the experience of others had demonstrated as necessary.

I know of two stone silos which are going up this fall, and neither are being reinforced. Now these silos are very strong and probably will not crack, for similar ones have now stood the test of several years, yet I would not care to assume the risk.

Should the masons be careless and not wet the stones when applying the mortar, the stones will draw the water from the mortar and it will crumble. Then when the tremendous pressure of one hundred tons of silage is applied, disaster results. So it is better to use wire or rods every few inches.

A good many people in northern latitudes do not provide a roof for their silo. Just because that is all right in milder sections does not make it successful there. An open silo will freeze easily. Better roof it tightly and keep the doors closed in winter.

Be sure to set the foundation on solid ground. Otherwise the silo may settle to one side and crack, making expensive repairs necessary. If rock prevents the digging of a deep foundation, blast it out, but remove the windows from the barn before the explosion. WILLIAM A. FREEHOFF.

The farmer who is always in a hurry will find that life will always be stewing, but never done just right.

**The Annual Index**

FARM AND FIRESIDE is preparing for its family of readers an index for this volume which closes September 25th. If you want the index which will outline all of the subject matter for the past year, write at once to the Index Editor, FARM AND FIRESIDE, Springfield, Ohio.

**The Farmer and the Banker**

MY FIRST advice to a farmer whose ambition is to improve his business methods is to open a bank-account if that has not already been done. The banks deserve more credit for improving business conditions on the farm than any other single institution. They serve, not only as markets for capital and credit, but as business counsellors and educators to the farmers. The opening of a bank-account is a distinct step forward toward the improvement of one's business methods. Almost unconsciously the depositor will acquire some of the exact methods of the banker; and his business will be improved accordingly. That the farmers all over the country are beginning to appreciate the banks is evident from the enormous growth of deposits in rural communities. It is claimed that fully ninety-five per cent. of the country's business is done by credit currency such as checks, drafts, notes, and the like. It is, therefore, of the utmost importance that the progressive farmer acquaint himself of the methods and practices of banking.

The most important advantages of banking may be set down under eight heads, as follows:

1. The depositor's credit and influence are measured largely by the condition of his bank-account.
2. A tendency to economize will be fostered by a desire to increase the bank balance.
3. The banker becomes the depositor's bookkeeper and business counsellor.
4. Security against fire and robbers.
5. Endorsed checks are the most satisfactory receipts for payments.
6. A depositor benefits the community by keeping the money in circulation.
7. Writing checks is more convenient than making change.
8. The bank will always loan to a good depositor in preference to one who is not a depositor.

Below is a convenient form of bank-account, which should be kept in addition to the stub record.

*Martin Harris in account with Citizens' Nat. Bank*

Date	No.	Payee	Deposits	Checks	Bal.
Apr. 1		Deposit	98 35		
1	350	Mrs. Harris		30	
1		Odell Seed Co		10	58 35
3	2	Emma Johnson		1 50	
3		Brown & Pickett		3	
		Deposit	70		
5	4	Salem Implement Co		20	103 85
	5	E. Hedmon		65	
	6	Empire Lumber Co		3 75	
6	7	County Recorder		3	
		Deposit	90		
8	8	Earle & Crockett		80	42 10
	9	Farmers' Supply Co.		15 40	
9	360	Frank Johnson		10	
	1	Soddard Hardware Co		3 50	
	2	Mrs. Harris		30	
		Deposit	40 50		
	3	Crown Fertilizer Co.		6 40	
	4	O. N. Smith		15 80	
13		Deposit	1 25		
	5	County Treasurer		30 40	
	6	Kimball Livery Co.		15	
	7	Brown & Pickett		2 50	
20	8	C. J. Olson & Son		15	63 60
	9	Farming & Bacon		10	
23	370	Crawford Hardware Co.		10 50	
	1	Brown & Pickett		13 30	29 80
		Proof:			
		Balance above	29 80		
		Outstanding			
		No. 361	3 50		
		366	15		
		369	10		
		Balance as per Pass Book	58 30		

I wish to call the reader's attention to the importance of numbering all the checks. This practice will save much time and will prevent many mistakes. The pass book should be handed to the bank every month to be balanced, and the monthly balance should be proved with the individual record, as shown in the illustration. J. A. BEXELL.

**Workable Farm Ideas**

IN A long trip across the country last year, I passed hundreds of corn-fields, some good, some bad and some indifferent. In one large section a fierce drought was prevailing. A good deal of rain had fallen in June, but after that not a drop. During the rainy spell the corn had grown too high for the cultivators to pass over it, and quite a number of farmers were going through the fields with one-horse cultivators. The weather was very warm, which made the task a disagreeable one. The object of running the one-horse cultivators between the rows was to form a dust-mulch to prevent the escape of moisture that was needed to mature the crop.

One farmer told me that it was the most unsatisfactory job he had ever done. The cultivators were run very shallow, but still thousands of roots were broken off; roots that were badly needed by the plants. Some of the farmers were drawing sections of harrows between the rows, which was both tedious and unsatisfactory. Many were doing nothing but hoping for more rain.

One young farmer who had nearly two hundred acres of corn seemed to have solved the problem effectively. He was mounted upon one horse, and was leading another along the adjoining row, each animal drawing the wheel of an old planter by means of a short singletree and chain. The wheels, of course, were laid flat and were leveling and pulverizing the baked surface of the soil in a manner to please the most exacting. None of the roots of the plants were disturbed and a splendid dust-mulch was formed on the surface, all cracks in the soil being filled and clods leveled down.

One small field which he had cultivated after the rains, and while the land was wet, was in bad shape, rough and very cloddy.

Through this he was drawing the wheels twice, leaving the surface in splendid condition to resist drought. I noticed that his near neighbors were preparing to utilize his "drought killer," as he called it. About three miles away from this inventor, I stopped to talk to a farmer who was trying to loosen the soil with single cultivators, and having a hot, rough time of it, and I told him about the planter-wheels. He had me go to his house and show him how to attach the singletree to the wheel. He was more than delighted, and immediately sent his two little boys to nephews living a mile or two away to tell them about the "drought killer" which a man had told them how to fix.

On this same trip I discovered a farmer "paving" the stalls in his stables in a manner that certainly was new to me. He wheeled fresh carth into the stalls until he

had them about right, then he covered the leveled earth about half an inch deep with coarse salt. This was well wet down until most of it was dissolved, then the soil was covered with an inch or two of straw or other short litter and tamped down with a piece of board fastened on the end of a rammer. In about a week the litter would be removed and the soil would be found harder than a hard, dry road.

He said it was the best flooring for horse-stalls that he knew of, because it was hard, yet springy. Some of the stalls he had fixed a week before seemed to be just right for stock. Hard and yet a little moist. I ran over to a neighbor of his to see how this sort of a stable floor appeared after three months' use, and found it solid and firm. I also looked into his poultry-house, where he had the same kind of a floor, and it was level and solid.

While in the poultry-house he came at me with the poultry question. I like to let a man have his own opinion on poultry matters, because most men have the idea that they know as much about it, or even a little more, than anybody else. He declared that there is no money in raising poultry at present prices, and he proposed to get rid of most of the fowls on the place, and that very soon.

I asked him how old his fowls were, and he said one, two and three years. I asked how he distinguished the old ones from the one-year-olds. He did not know. I asked how he distinguished the old ones from the young. He got a little huffy and said he'd be dinged if he could tell one from the other. I suggested that he get his poultry-keeping down to a common business basis and then he could say something worth listening to. FRED GRUNDY.

**Of National Importance**

Farmers' National Congress, Columbus, Ohio. October 12, 1911  
 The International Dry-Farming Congress, Colorado Springs, Colorado. October 16-21, 1911  
 International Dairy Show, Milwaukee, Wisconsin. October 10-18, 1911

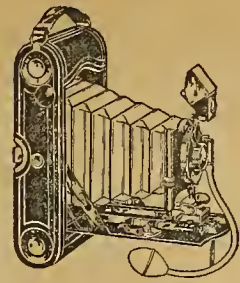

*If it isn't an Eastman, it isn't a Kodak.*

**KODAK**

means more than a mere vacation accessory. It means home pictures, portraits of one's family and friends, intimate pictures that become priceless as the years go by.

And picture making is very simple by the Kodak system. Ask your dealer or write us for "At Home with the Kodak," a beautifully illustrated booklet about home picture making, that not only shows the pleasing results that can easily be obtained, but shows how they are made.

EASTMAN KODAK CO.,  
 382 State St., Rochester, N. Y.

**1 MAN AND ONE HORSE**  
**BALE**  
**1 TON AN HOUR**

**Do Your Baling Cheaply**  
 Our Daisy SELF-THREADING, self-feeding one-horse hay press is the only one on which one man can do all the work. First successful self-threading device. The self-feed and automatic condenser materially increase results. Open side hopper. Write today for circular K-146 which gives prices and reports of actual work. Geo. Ertel Co. Quincy, Ill.

**The Money Making "Eiff" Power Press** Get Catalog Free

The favorite with hay-makers everywhere. The most and best work with least labor. Powerful, safe, long lived, 48 styles and sizes of presses. Horse and steam power. Send for catalog.

Collins Plow Co., 1116 Hampshire St., Quincy, Ill.

125 Acres Bordering River  
 Stock and Tools Included  
 Splendid stock and dairy farm cuts 50 tons of hay, brook-watered pasture for 35 cows; 200 bearing fruit trees, 500 cords of wood, lots of timber; 2-story 10-room house, big barn, other outbuildings, maple shade; owner includes 11 cows, 3 heifers, all farming machinery and tools; price for everything only \$4000, part cash. Complete details and traveling directions to see this and other big, equipped, money-making farms see page 38, Strout's Farm Catalogue No. 34, copy free. Station 2699, E. A. Strout, Union Bank Bldg., Pittsburg, Pa.

**50,000 MEN WANTED**  
**In Western Canada**

200 Million Bushels Wheat to Be Harvested

**HARVEST HELP IN GREAT DEMAND**

Reports from the Provinces of Manitoba, Saskatchewan and Alberta (Western Canada) indicate one of the best crops ever raised on the continent. To harvest this crop will require at least 50,000 harvesters.

**Low Rates will be given on All Canadian Roads**

Excursions are run daily and full particulars will be given on application to the following authorized Canadian Government Agents. The rates are made to apply to all who wish to take advantage of them for the purpose of inspecting the grain fields of Western Canada, and the wonderful opportunities there offered for those who wish to invest, and also those who wish to take up actual farm life. Apply at once to

**Canadian Government Agents**  
 H. M. WILLIAMS, 413 Gardner Bldg., TOLEDO, OHIO  
 J. S. CRAWFORD  
 30 Syracuse Savings Bank Bldg., SYRACUSE, N. Y.

**Bigger Profits With This Power**

More work at less expense and less repair cost than with any other engine made. Let us prove it. Write for Free Leffel Book. You are not prepared to buy until you get our proposition.

**Leffel Steam Engines**

are the simplest, most durable, and economical power outfits made. Large variety of uses. No breakdowns, no delays. Don't dole out on any outfit until you get the LEFFEL FREE BOOK. Address  
 James Leffel & Co. Box 266 Springfield, O.

## "How to Grow and Market Fruit"

A new hundred-page book. Contains the lessons of our own wide experience, and of the experiences of hundreds of successful orchardists over the country. Oily men, new at fruit-growing, will need little other guidance; old orchardists will glean new ideas from it. The book contains all the latest facts as to varieties—their adaptability and differences—and the latest methods of spraying, cultivating and feeding trees. Not only tells *how*, but shows *how*, with a great many orchard pictures. We are qualified to know what we are talking about, for our young trees have become the standard, and we have over two hundred thousand bearing trees, in widely scattered orchards. Price 50 cents, which is rebated on first \$5.00 order.

HARRISON'S NURSERIES  
Erie Avenue, Berlin, Maryland  
Ten valuable farms for sale.



Ready-Mixed House & Barn  
**BROWN SEAL PAINT.**  
Highest Quality  
ever sold direct to the consumer. All middlemen's profits saved.  
Write for FREE Color Card, Price List and Booklet which tells the whole story.  
YUMA PAINT CO.  
820 E. Monument Ave., Dayton, O.

APPLE BARRELS IN CAR LOTS OR LESS  
Low price, prompt shipment. GILLES, MEDINA, N.Y.

## A Good Position Open

THOUSANDS of men and women keep pegging on in the same old way, barely making a living, perhaps without steady employment. They don't know how to get a position that will pay better.

Here is a chance for someone in your county to get a permanent position that will pay well. It is mighty pleasant work, and we guarantee good pay.

If you want to make more money than you do now or if you are looking for a good job, write to us to-day.

FARM AND FIRESIDE  
SPRINGFIELD, OHIO

## GARDENING

By T. GREINER

### Possibilities in Eggplants

**A**N EGGPLANT requires about six square feet of ground. With an abundance of food (furnished in a very heavy manure application), one plant is capable, in this climate, to produce, during the season, ten to twelve eggs, worth in a retail market at least five cents each. This means a return of not less than fifty to sixty cents from one plant. There are many home gardeners who like eggplant, but think they cannot grow it, and do not attempt to grow it. Yet they are willing to pay the price for an occasional "egg." I can always sell my surplus. There are also many people who do not even know the taste of eggplant, and who would like them and be willing to buy them if once made acquainted with this delicious vegetable. Many would use it in preference to meat after they once have found out what it is. If you grow eggplants, let your neighbor who knows it not, have a taste of it. It will make him a willing customer of yours. Or possibly it will convert him to the practice of planting eggplants. The one difficulty the home gardener usually finds with that crop is that of securing good plants at planting-time. He may have to get them from a professional plant-grower. But it is not so very difficult to grow the plants when one understands their nature and requirements.

### It is Easy to be Vegetarian

Just at this time we have so many good things from the garden that we do not miss the meat; so many that we can have a change almost every day in the week. We have sweet corn one day; cooked tomatoes and mashed potatoes the next; fried eggplant the third; lima beans, or succotash, or creamed carrots, or summer squash, or other things, on the other days. In fact, there is no end to the variations in a household having access to a good garden and being presided over by a good cook. It makes good, cheap and enjoyable living.

### Trees Near the Garden

Trees, whether planted for fruit or for shade, even the poplar and walnut, will do very well in closest touch with the garden. But woe to the poor plant grown from seed, or set out, within the circle of the feeding-grounds of a large tree or trees. All the manure you can pile on the land will do it but little, if any, good. For it is not so much the lack of food but that of moisture which usually stunts and starves the garden plants. I have not for many years raised one good crop of any vegetable planted within several

rods of a cluster of poplars and Japanese and black walnuts in the farther end of my garden. The land is a good loam, and annually quite well manured. When we examine that soil, at this time, however, we find it dust-dry clear down as far as we might be willing to dig. The tree-roots have pumped all the water out of the subsoil, and there was none left to make up from below for the loss of moisture by evaporation from the surface. We cannot expect our ordinary garden crops to thrive in mere dust. I believe, however, that if I could turn water enough on this patch to supply the needs of the trees, I would also be able, by heavy manuring, to grow good crops of vegetables close up to the trees. This may be a valuable suggestion to people living in the suburbs of village or city, people who have, but little land, yet may wish to have a few trees, and a good garden, also. Some crops do fairly well in a half-shady situation. Among them we have currants, gooseberries, blackberries, rhubarb, perhaps strawberries, lettuce, parsley, celery, dandelion, etc. It is water that we will have to provide to make the combination of tree and garden crop a success. The water can often be had from the village or city hydrant.

### The Staked Tomatoes

I am quite pleased with my staked tomato-plants. The two branches to which each plant is trimmed carry their heads pretty well up to the top of the six-foot stakes and are covered all along the stakes with their great clusters of smooth tomatoes ripening fast from the bottom up. Soon I shall have to train the upper extremities over the cross-pieces connecting the posts across the tops. Altogether it is one of the sights of the garden. Next season I shall try another style of support; namely, two permanent posts at the ends, with small stakes every six or eight feet between and a number of wires stretched horizontally between the posts, about a foot apart, after the fashion of a grape trellis.

### Poison for Aster Bugs

A. C. H., of Mukwonago, Wisconsin, has had some sad experience with black bugs on pinks, sweet-williams, asters, etc., and describes these bugs as being about a half inch long, very slender, very vigorous and voracious, and a glossy black in color. The plants were sprinkled with Paris-green water, a teaspoonful of green to four gallons of water. This finished the bugs. When a stronger dose was used, it finished both the bugs and the plants. My preference, as stated before this, is arsenate of lead. This will finish the "bugs" without injuring the plants. So far as I know, it will kill any creature that eats enough of the leaves.

### Not Large, but Good

My Spanish onions are not going to reach their usual size this year. At least I do not find the pound specimens among them. The Prizetakers are small. The terrible heat in July was too much for them. Among the Gibralters I have at least a good many half-pound specimens. While the Prizetakers have already been harvested, giving us small bulbs only, the tops of the Gibralters are just beginning to show signs of dying down, and the bulbs will yet increase slightly in size. We have them on the table right along, however, and they are just as good as they ever were, mild and sweet, and in no way inferior to the imported Spanish onions as we find them during a large share of the year in our stores. I do not believe that many specimens of my Gibralters will be allowed to go to waste. Neither do I intend to sell any of my crop by the bushel. They will be divided up in peach-baskets so as to reach around among my old customers who have learned how to appreciate this onion, and they will go at forty or fifty cents per basket, more likely at the latter figure than at the former. These onions cannot be had in the open market this year, for the simple reason that the entire supply of seed last spring consisted only of a very few pounds. In view of the great value of this onion, both for the home gardener and the commercial grower, I hope that some of our seed-growers, especially in California, will make greater efforts in producing the seed of this variety. I know of no unsurmountable obstacles in the way of growing Gibraltar-onion seed.

### A Season for Sweet Corn

This seems to be just the season for sweet corn. Hot days and hot nights push the stalks right along, and we shall have a chance to have nice, tender ears in their prime for about eight weeks or more. There are several sorts that are very early, and while the ears are not very large, they are very good if gathered at proper stage of growth and boiled, steamed or roasted soon after they are broken from the stalk. For freshness counts in sweet corn as much as in any garden vegetable. We now have the Golden Bantam, one of the sweetest and tenderest of all sweet corns, notwithstanding its yellow color. It is always at a premium, and just the kind for a fancy market and fancy prices. Gardeners in the right location can do well with it. There are many good mid-season varieties. My favorites were

Early Champion and Metropolitan. Failing to obtain seed of these, I had to plant others. The outcome may soon be told. For late I still prefer the old Evergreen, and as usual I have made repeated plantings, the latest about the middle of June. The outlook now is that this planting will have plenty of time to produce good ears for table and market. Usually there is a good demand for sweet corn late in the fall, and at better prices than in the very height of the season.

### Save Sweet Corn for Seed

Seed-dealers usually ask a good price for seed sweet corn, and you are not sure then that it is good unless you know the dealer to be reliable and experienced in the business. You can save money and possibly disappointment for another year if you save your own seed-corn. Easily done, too, so far as the earlier sorts are concerned. We select some of the best-eared stalks in the patch and mark them by tying a piece of string or a strip of cloth to them and give instructions to the members of the family not to gather any ear from a marked stalk. These early varieties ripen early, and when of proper maturity as shown by the dead husks, the ears are gathered and tied in braids, then hung up in a dry and airy place out of the reach of rodents or other corn-lovers. If we have more than we want for our own planting, all the better. The neighbors will want some, and will be willing to pay a fair price for it. Instead of paying out money buying sweet-corn seed, you can get money by selling it. The later the variety, however, the more pains must be taken with it if we wish to save any for seed. Stowell's Evergreen and sorts of that season should be planted very early to give them a chance to ripen as early as possible. Save the earliest ears and let them get as ripe as can be done safely. Gather the ears before frost and hang them up in a frost-free garret or other room. Never expose them to freezing until thoroughly cured. There is a big demand for seed sweet corn every spring, and the prices that even the local dealers will pay for it (should you have more than can be sold to neighbors) are such as to pay well for the trouble of growing and saving it.

### Repairing Root Damage

Several enemies are liable to attack the roots of cucurbits, especially of squashes and pumpkins. I have seen the connection between top and root of such vines entirely severed by the disgustingly fat grubs of the squash-borer, and the roots of other vines of this kind severely injured by the grub or larva of the yellow-striped cucumber-beetle. On squash and pumpkin vines I have often repaired the damage by covering the first joints of the vines with fresh earth, packing it firmly over it. The vines readily emit roots from the joints if kept thus covered, and the vine or branch will live and produce "fruit" even if cut entirely off from its original root. When we are hoeing such vines at this time, we make a practice of covering some of the joints for good luck, whether they seem to be infested with the enemies or not. It does not require extra effort. It may save the usefulness of some of the plants.

### The Phoebe

THE phoebe is the first of the flycatcher family to come north in the spring; coming when snow-squalls are in the air or snow may again cover the ground. They arrive before the insects, on which they feed in summer, have hatched or come out of "winter quarters."

Why do they come so early? They have a purpose, and that is to feast on the female canker-worm moth as she crawls up the tree-trunks during the warm days of early spring, to lay her



eggs. Thus at one blow the phoebe kills not only the moth, but from sixty to one hundred worms in the eggs that would soon have hatched.

I had a man tell me he allowed his boys to destroy the phoebe nests that were built under an open shed on the place. "Because," said he, "they are 'bee martins' and my mother once saw one near a bee-hive killing the bees." This may have been so, but that charge should not be laid at the door of all of them, as a species. They are useful birds; so, boys, if a phoebe builds her nest in an accessible place on a bridge, cliff or under a shed, do not molest, but protect her nest and the young. H. W. WEISGERBER.

ANYBODY CAN LAY IT.

## Rubber Roofing

Warranted For Twenty-Five Years.  
**FREIGHT PAID** To Any Station East of Rocky Mountains, except Texas, Okla., Colo., N. D., S. D., Wyo., Mont., N. M., La., Ga., Ala., Miss. and Fla., on all orders of three rolls or more. Special Prices to these States on request.

ONE-PLY .... Weighs 35 lbs., 108 Square Feet, \$1.10 per roll.  
TWO-PLY ... Weighs 45 lbs., 108 Square Feet, \$1.30 per roll.  
THREE-PLY . Weighs 55 lbs., 108 Square Feet, \$1.50 per roll.

TERMS CASH: We save you the wholesalers' and retailers' profit. These special prices only hold good for immediate shipment.

**Indestructible by Heat, Cold, Sun or Rain.**

Write for FREE SAMPLES or order direct from this advertisement. Satisfaction guaranteed or money refunded. We refer you to Southern Illinois National Bank.  
CENTURY MANUFACTURING COMPANY, Dept. 624, East St. Louis, Ills.

## POTASH PAYS Profit in Wheat

Wheat is profitable if the yield is good. A good yield is insured by using the right fertilizer.

No crop gives better profits for a small fertilizer expenditure provided intelligence is used in buying, and a fertilizer is used that is suited to the soil. Almost any fertilizer will increase the wheat crop, but why not get the one that will give the best profit? This is the kind in which the phosphate is balanced with

# POTASH

Insist on 6 to 8 per cent. of Potash in wheat fertilizer. Some of the best growers use 10 per cent. If you have trouble in getting such brands buy Potash and add it yourself. We will sell it to you in any amount from 1 bag (200 lbs.) up. Write us for prices, naming amount needed, and for free books on *Fall Fertilizers and Home Mising*. They will save money for you.

GERMAN KALI WORKS, Inc.  
Baltimore: Continental Bldg.  
Chicago: Monadnock Block  
New Orleans: Whitlow Central Bank Bldg.





## Garden and Orchard

### Raising Flowers as a Farm Industry

MANY men consider raising flowers to be a woman's pastime. I was once guilty of that error myself. This year, however, I took to market eighty dozen flowers which sell at a wholesale price of twenty-five cents a dozen to a laundryman who retails them all at thirty-five cents a dozen in a near-by town of about 1,700 inhabitants.

The space required to grow this twenty dollars' worth of flowers was a door-yard garden less than fifty feet square. We grew Lily-of-the-valley and double Roman White Narcissus. Both are perennial and need scarcely any care after they are once set. I do not think that I spent more than one day altogether in caring for my bed during the entire year. It took three of us one-half day to prepare the eighty dozen for market.

Twenty dollars for two and one-half days' work on a bed fifty feet square is at the rate of \$5 a day for wages and \$125 an acre rent for the land. Besides, the work of caring for the flowers and marketing them is almost repaid in the way of enjoyment and added beauty of the home. I am planning to enlarge my beds extensively this fall.

#### How to Start a Bed

For the benefit of any who may wish to start a flower-bed of the above varieties for profit, I offer the following suggestions:

The bulbs can be procured from seedsmen and florists at about twenty cents per dozen. They should be set in the fall (September or October) on ground that is loamy and shaded. The beds should be spaded up about eight inches deep and the bulbs set with their crowns about one inch below the surface of the soil, in rows one foot apart and at intervals of six inches in the row. Each spring as soon as the snow goes off the flower-beds should be mulched with a liberal layer of fine horse-manure or rich soil.

Decoration Day offers a market for both the above varieties of flowers. Arrange with some merchant or florist in your town to handle your flowers on commission. He may not sell all you furnish the first year, but if your village is large and your flowers are nice, it will not be many years before he will have built up a trade that will require all that you can furnish. If you are unable to sell your flowers in your home village, then ship them to some florist in a large city. Yet you cannot expect as much from flowers sold in this way.

In preparing the flowers for market, they are picked with as long stems as possible and placed in jars of water to freshen. Then they are sorted carefully and packed loosely in large pasteboard boxes, lined with thin, waxed paper, along with two leaves of their kind for each bloom. In the boxes they are sprinkled with water, and the boxes then covered and set in a cool place until all are ready for delivery. When delivered, the flowers should be immediately removed from the boxes and placed in pretty vases for display and sale. It may pay you to bear the expense of advertising your flowers for sale, providing your commission merchant is unwilling to do so.

Lily-of-the-valley and Narcissus multiply rapidly, and in three or four years one will have stock to enlarge the beds or to sell.

MONROE CONKLIN, JR.

### Tripod Fruit Ladder



THE tripod step-ladder is one of the handiest devices yet intended for orchard work. The ordinary four-legged step-ladder is not safe except on perfectly level surfaces, while to use a common ladder among trees, and especially in the peach-orchard, is quite out of the question. Hence the tripod ladder is just the ladder needed by

the fruit-grower for pruning and for harvesting the fruit. I will give a description of the ladder which I made. It may prove suggestive. My ladder is eight feet long and has eight steps, one foot apart. The wood is all yellow pine, except the pole, which is of white oak. All lumber should be well seasoned. The two rails are seven eighths by three inches, eight feet long. The steps are of the same thickness and about four inches wide. In nailing the ladder together, the rails, when placed in position, are one foot apart at the top and five feet apart at the bottom, thus giving the ladder a wide flare. The steps are then sawed to fit. The platform, nailed on top of the rails, is an inch board six by eighteen inches. The third rail, or pole, is a piece of oak about one and three-fourths inches square, which will

be a little less than eight feet. The three rails are pointed at the lower ends so they will catch in the ground when the ladder is set up. The third rail is made to fold, being fastened in this way: Pass a half-inch bolt three inches under the top platform and through the pine rails near the back edge. The bolt will be about fifteen inches long. This serves as a shaft for the oak pole and also as a brace for the ladder. Bolt a six-inch oak block (of same size as pole) lengthwise onto the upper end of the pole, then bore a hole through the side of the block so that the bolt may pass through it. Two braces of iron, one half by one eighth by eighteen inches, are bent and holes drilled in the one end so that the bolt may pass through these braces. The pole (or rather the block) rests about the middle of the bolt and the braces against the inside of the pine rails. The bolt is stationary, the nuts outside of the rails being drawn tight. The braces are bent so that the other ends may be bolted against the side of the pole, one on each side, and two bolts passing through both braces and pole. Long bolts are also passed under the middle and bottom steps to brace the ladder. This ladder can be used on steep hillsides. It may, of course, be made longer than eight feet if desired.

DAVID PLANK.

### Preparing Potato Land

THIS land around Port Ewen, New York, is not a potato-growing section, the soil as a rule being too much of a clayey nature to suit its growth. In this county not enough are raised for home consumption, and one can always get, at least, fifty cents per bushel for what they grow. So some find it profitable to plant an acre or two every year. Many plant potatoes with such poor success that they do not grow enough for family use. To grow them successfully on a clay soil requires some previous preparation. One has to start in the fall previous, or even sooner than that.

Assuming that the corn has been planted on a clover-sod and manured, one should pick out a suitable portion of the field, and about August 1st sow crimson clover in the growing corn, working the seed in with a one-horse cultivator. As a rule, this takes well and makes quite a fall growth. It is plowed under any time before freezing and



This potato weighed one and one half pounds. It was of good quality, too. Raised in New York, average conditions

plowed deeply. Manure is immediately applied at the rate of twelve to fifteen tons per acre and the land allowed to lie until spring. If one has not some clover in corn in preparation for the future potato crop, he can plow up, in the fall, a piece of the clover-field where the plants have been allowed to grow and remain on the ground. The idea is to get a large amount of vegetable matter turned under and mixed with the soil to lighten it and make it loose and permeable. Potatoes will not do much on clay soil unless it is made loose in this manner. This treatment will also improve the land in its relation to the water-supply both from above and below, and the potato crop is one that is very fastidious in this regard. A spot should be selected of good, natural drainage. Any place may be improved by underdrains.

In the spring another deep plowing should be given. It should not be left to suit convenience or until you get ready to plant, but should be done just at the time when the ground first gets in proper condition. Then the ground should be harrowed occasionally until time to plant. By this time the decaying crop turned under, and the coat of manure applied afterward will be thoroughly mixed and the ground be in good tilth. There will also be a fair supply of nitrogen ready for the crop, and a fertilizer should be used that does not contain too much of that element, or the potatoes will grow too much to vine. There should not be over two per cent, and that mostly in the form of nitrates to force early growth; 150 pounds nitrate of soda, 1,450 pounds bone black or acid phosphate, 400 pounds sulphate potash. This makes an excellent mixture to use under these circumstances. SYLVANUS VAN AKEN.

### Prepare for Watermelons

WHILE the watermelon is not classed among the hardy plants, yet, if the proper method of preparing the soil and cultivation of the plant is pursued, it will generally make a good return for our trouble. This is especially true under our Virginia conditions.

Watermelons do best on a light, sandy soil, with some moisture! too much will destroy the plant. If the ground has not

been cultivated the year previous, it must be fallowed in September with a double plow; otherwise it can be plowed in November or December. In December, take a single plow and lay off the rows both ways, ten feet apart. The hill should be made at the intersection of the rows. Take a hoe and dig a hole where the hill will be, below the surface, in the shape of a basin, large enough to hold a gallon of well-rotted manure, then cover with dirt eight inches; this ends the fall preparation. In the spring, after all danger of frost is over, take a disk-harrow and break the ground thoroughly, avoiding the little mounds made in the fall, then use a plank drag to level. With a hoe dig well the mounds and add enough soil to make a hill two feet wide by eight inches high; firm the soil on top of the hill so that it will retain the moisture. Work a handful of some high-grade fertilizer into the upper part of the hill to give the young plant a start.

Be sure you have good seed and that the melon is suited to your locality. With the finger make four holes in each hill, to the depth of an inch and a half; drop five seeds in each hole and cover with moist earth. If seeds are soaked, they will come up sooner. Not later than a week, thin out to three plants in a hole; and as soon as large enough to be out of danger from bugs, thin out to two plants in a hill.

Within ten days after plants are up work the hills with a double-prong hoe, and run the fine-tooth cultivator over the plat both ways, to keep the grass down. Keep this up from time to time until the vines get too long to go between them, after this, if any grass appears, cut it up with a weeding-hoe. At the last working throw a good deal of dirt around the hill.

Never work the vines just after a rain or when the dew is on them. If bugs attack the plants, get tobacco stalks or stems and place them upon the hill around the plants; if no stalks are to be had, take a bucket of fresh cow-manure, pour water in until a thin slime is made; put this on the plants after sunset and repeat after every rain until vines are too large for bugs to injure them.

E. W. ARMISTEAD.

### Starting Nut-Bearing Trees

A NEW YORK reader is in quest of information on the subject of planting walnuts, hickory-nuts and butternuts.

All of these nuts grow readily when not allowed to become too much dried out or injured by molding.

After the nuts are matured, and separate readily from the outside husk, place them in flats, shallow boxes fitted with light earth or sand. Bury the flats a few inches under surface of the ground, where they will remain moist (but not wet) until the following spring. Plant in nursery row early in the spring.

B. F. W. T.



### White Lead on the Farm Outbuildings

Every building on your farm that is built of good lumber deserves good paint. Thorough painting means lower repair bills, longer life for the building, and an attractive, prosperous appearance for your whole place.

### "Dutch Boy Painter" Pure White Lead

and pure linseed oil makes an ideal paint for farm buildings. It protects the surface perfectly and keeps out the rain and frost. Now is the time to protect your buildings against the fall rains and the winter weather.

#### Our Free Painting Helps

We will send you free on request color schemes and miscellaneous painting instructions that you will find of real, practical value. Ask for Helps 1347.

**NATIONAL LEAD CO.**  
New York Cleveland Chicago St. Louis  
Boston Buffalo Cincinnati San Francisco  
(John T. Lewis & Bros. Co., Philadelphia)  
(National Lead and Oil Co., Pittsburgh)

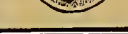

FOR INFORMATION AS TO LANDS IN

**The Nation's Garden Spot—**  
THAT GREAT FRUIT AND TRUCK GROWING SECTION—  
along the  
**Atlantic Coast Line RAILROAD**

in Virginia, North and South Carolina, Georgia, Alabama and Florida, write to  
WILBUR McCOY, E. N. CLARK,  
A. & I. Agt. for Florida, A. & I. Agt. for Virginia  
Alabama, Georgia, and the Carolinas,  
Jacksonville, Fla., Wilmington, N. C.

### CORN HARVESTER

Something new—Cuts complete shock without stopping team. Makes shock row 60 to 80 rods apart and leaves the land clear for seeding or plowing—just what the farmer has been needing. Sold direct. They are guaranteed. Price \$20.00. Write for circulars. **CORN KING HARVESTER CO., Box 1536, Salina, Kansas.**

**CORN HARVESTER** with Binder Attachment cuts and throws in piles on harvester or winrow. Man and horse cuts and shocks equal with a Corn Harvester. Sold in every state. Price \$20 with Binder Attachment. S. C. MONTGOMERY, of Texaline, Tex., writes:—"The harvester has proven all you claim for it. With the assistance of one man cut and bound over 100 acres of Corn, Kafir Corn and Maize last year." Testimonials and catalog free, showing pictures of harvester. New Process Mfg. Co., Salina, Kan.

## Cut Down Expenses With An IHC Gasoline Engine

SAVING time and work on the farm cuts down expenses—makes farm life more pleasant and more profitable. Of all modern work and time savers—an IHC gasoline engine stands first. It operates the many machines that now mean hard, disagreeable, expensive hand labor. It solves the "keep-the-boys-on-the-farm" and "hired-help" problem.

Wouldn't you like to have a simple, economical, efficient, durable IHC—the engine that thousands of other progressive farmers are using with such great profit and satisfaction? Wouldn't you like to have it run your cream separator, feed cutter, pump, fanning mill, saw, grindstone, thresher, clover huller, electric light plant, washing machine, and do the other odd jobs around your farm?

An IHC engine costs less than any other if you measure by the years of service. And you can get just the IHC you want. There is

## A Style and Size For You

IHC Gasoline Engines are made in the following styles and sizes:

Vertical type—2, 3, 25, and 35-H. P.; horizontal—1 to 25-H. P.; semi-portable—1 to 8-H. P.; portable—1 to 25-H. P.; traction—12 to 45-H. P.; sawing, pumping, spraying, and grinding outfits, etc. Built to operate on gas, gasoline, kerosene, distillate, or alcohol. Air-cooled or water-cooled. Don't buy any engine till you investigate the IHC line. Learn all the facts about the design, materials, and workmanship that go into the construction of IHC engines—then decide. See the IHC local dealer at once, or, write us today for our new catalogue.

### IHC Service Bureau

The Bureau is a clearing house of agricultural data. It aims to learn the best ways of doing things on the farm and then distribute the information. Your individual experience may help others. Send your problem to the IHC Service Bureau.

**INTERNATIONAL HARVESTER COMPANY OF AMERICA**  
(Incorporated)

Chicago USA

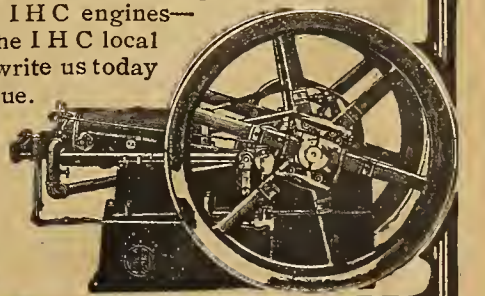

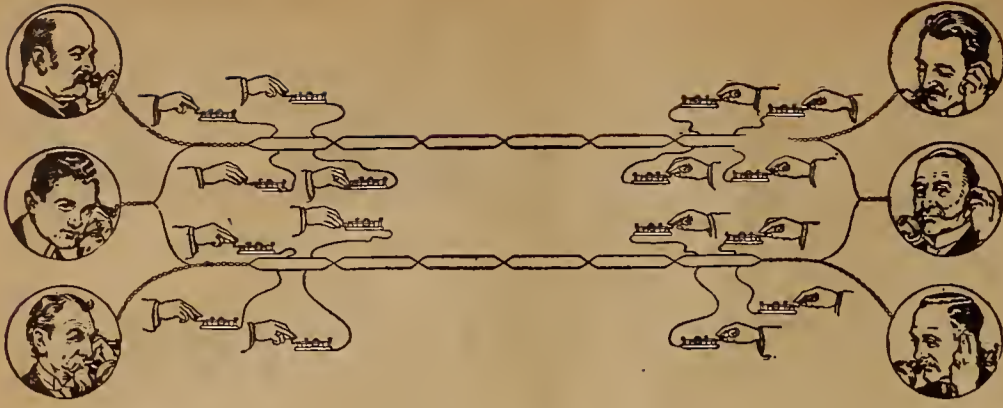

## Double Tracking The Bell Highway

Two of the greatest factors in modern civilization—the telephone and telegraph—now work hand in hand. Heretofore each was a separate and distinct system and transmitted the spoken or written messages of the nation with no little degree of efficiency. Co-operation has greatly increased this efficiency.

The simple diagram above strikingly illustrates one of the mechanical advantages of co-operation. It shows that six persons can now talk over two pairs of wires *at the same time* that eight telegraph operators send eight telegrams *over the same wires*. With such joint use of equipment there is economy; without it, waste.

While there is this joint use of trunk line plant by both companies, the telephone and telegraph services are distinct and different. The

telephone system furnishes a circuit and lets you do your own talking. It furnishes a highway of communication. The telegraph company, on the other hand, receives your message and then transmits and delivers it without your further attention.

The telegraph excels in carrying the big load of correspondence between distant centers of population; the telephone connects individuals, so that men, women and children can carry on direct conversations.

Already the co-operation of the Western Union and the Bell Systems has resulted in better and more economical public service. Further improvements and economies are expected, until time and distance are annihilated by the universal use of electrical transmission for written or personal communication.



AMERICAN TELEPHONE AND TELEGRAPH COMPANY  
AND ASSOCIATED COMPANIES

One Policy      One System      Universal Service

**Monarch Hydraulic Cider Press**  
Great strength and capacity; all sizes; also gasoline engines, steam engines, saw-mills, threshers. Catalog free.  
Monarch Machinery Co., 603 Hudson Terminal, New York

**WANTED—MEN**  
BRAKEMEN, FIREMEN, ELECTRIC MOTORMEN, CONDUCTORS, TRAIN PORTERS  
Hundreds put to work. \$65 to \$150 per month. 500 more wanted. Experience unnecessary. Application blank and map of new lines free. Give age and position wanted. Enclose stamp.  
L. Railway C. I., No. 36 Indianapolis, Ind.

## What's All This Talk About Engine Prices, Eh?

These cock and bull stories telling the farmers of the United States how they can save big sums of money if they will only buy their gasoline engines from so-called "direct-to-the-consumer" firms. Concerns that are spending hundreds of thousands of dollars on big, flaring advertisements trying to hammer the word "free" in every line, telling you they save middleman's profits. Surely the farmers of this country are not going price-mad. Hasn't *quality* got something to do about a gasoline engine the same as it has to do with a plow, a horse or a stride of fence? How much longer are you going to let this low-price talk pull the wool over your eyes? Low price generally means low quality; in the gasoline engine business it means low quality *always*. Would you like a really first-class *quality* engine that will stand up to its work *at all times* and under *all conditions*? We are selling

## GASOLINE ENGINES

that need no bolstering up by catch talk or low price. If you want to buy an engine on the same principle as you sell your crops—*quality*—come our way. Buy from us, get a gasoline engine made by competent engineers, sold under a written guarantee by a firm that has a \$600,000 capital, all paid up. Can we save you money? Yes. How? Because the engines we sell have *quality built into them*—quality, simplicity, durability—features that induce our farmer friends to recommend our engines to their neighbors, enabling us to make big sales and be contented with a small profit. Our gasoline engines are made specially for farm use—running the cream separator, chopping machines, ensilage cutters, bone grinders, churns, pumping well water, etc. Big savers in time, labor, money and bired help. But our policy is *quality* as well as low price—not low price only. Our gasoline engines don't consume as much fuel, have no complicated parts, are up to the specified horse power and wear many years longer than these "cheap" machines.

Remember these things. We sell *quality* engines only, we guarantee them, we have a capital of \$600,000 real money and we know how common honesty builds up a big business. Write for illustrated book and prices—we're bent on saving the farmer from being duped any longer on this gasoline engine business. Write now for Bulletin "C"—you are liable to forget it later.

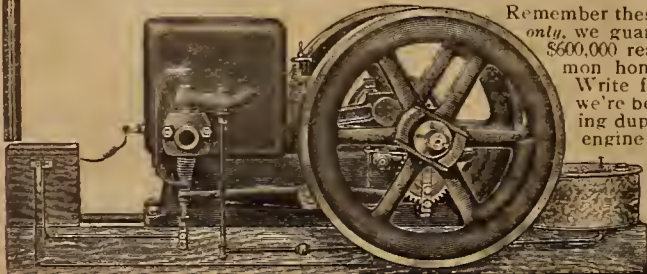

THE STANDARD SCALE & SUPPLY CO.  
PITTSBURG, PA.

## Headwork Shop That Turns Out Ideas About Farm Life and Work

### Keep the Wires Tight

NO DOUBT many farmers are troubled with broken wire fences and we all know how difficult it is to get the wires spliced and tightened when once they are broken. It is almost impossible to find anything strong enough to hitch the block to, and many of us haven't the blocks. I have devised the following plan, which I find satisfactory: Take an old buggy wheel, attach chain or rope to each side of hub. To the opposite ends of chain fasten never-slip wire grips. Apply grips to each end of broken wire, as



in illustration. Turn the wheel until the wire is tight, then splice, and proceed the same with other broken places until your fence is as tight as before broken.

When tightening the bottom wires, the wheel can be laid flat on the ground, in order to have a straight pull. M. V. BARTRAM.

THIS is the best stretcher for wire fencing I have ever used and it is very cheap. I explain as follows: A A are corner posts with braces. The wire is unrolled and stapled to corner posts, A A. Then near the center post a round timber (C) about four or five inches in diameter is placed. We bore two holes through timber C. Wire is fastened to each side. By means of a long bar (E) we turn timber C. When wire is tight, we pass bolt D through one of the holes in timber C, and it is held from turning back by post B. At any time the wire becomes slack it can be made tight by using lever E and changing bolt D.

WESLEY BUTLER.

OLD wire fences always get loose and rickety. It is a big job to tear them down and stretch the wires again. This is how I save lots of work making old wire fences as good as new: I get a pole three or four inches in diameter and as long as the post, split it into halves and put a half in the middle of post under the wires after pulling the staples, flat side next to the post. Then I tack it there with a small nail. Next I staple the wires on both sides of the split pole as indicated in the sketch. Two or three of these will tighten forty rods of wire.

EPHRAIM GREGORY.

### Handy Wood-Box



HERE is a sketch of a "built-in-the-wall" wood-box, which we have used for many years, and which does away with the unsightly, old-fashioned wood-box, which is usual in most kitchens. Readers of FARM AND FIRESIDE will find this box to be convenient, out of the way, and it saves opening and closing doors while filling. This saves cleaning rubbish and dust brought in with the wood. The box can be made any size, and if the work is properly done, it will be as tight and warm as any other part of the wall. Double board the whole box, using good paper in between, and make the outside cover fit very close with a flange at the edges. The door inside may be of single boarding, and made to match the wainscoting. Fit a small-size door set to it and it will then stay closed merely by pushing it shut. This is handier than a button. We have a wood-shed adjoining our kitchen, and so find a box of this sort most convenient.

JOHN J. KADLETZ.

### To Make Husking Easier

A BINK which I believe is very useful consists of a temporary table behind the wagon as shown, which admits of an upright position and free action at all times while husking. A minimum of false and useless motions of carrying and placing trestles, and the priceless satisfaction in feeling that when you have worked hard all day until dark you have not to face the tedious job of clawing up your corn from the ground and shocking the stover. This table (about seven by three and the height of the box) is found just where you left it last night, and quickly hooked on rear of the box after you have driven up and stopped opposite a point midway between the first two standing

shocks. As soon as the driver has blanketed his team, his partner on the corn side has taken off the two hands and made them into one, and has thrown an armful of corn on the table. You step back and "go to it." The good corn goes over the shoveling-board, the nubs go under and the occasional seed-ear goes into the box swung under the rear end of wagon-box with the jug of cider. Promptly as your partner tosses you his "empties" you grab a tie from a bundle suspended near and make a bundle quickly, clearing the table for your partner's "next." As bundles accumulate you shock them, and at the last your partner comes over with his double band and you pass the end around to him, and the first shock of stover is tied, and you have started up your team to the next. Repeat the dose until relieved. When dark comes, and your team unblanketed, you simply unhook your table and go. Your work is always clean behind you, rain, shine or snow. F. D. SMITH.

### To Lengthen Spokes

AS IT often happens, the spokes in a small plow-wheel become loose in the hub. I will tell how I fixed one for myself. Take the wheel to the anvil, if you have one, and hammer the spokes about half-way from the hub to the tire. This will flatten the spokes slightly, and it also makes them longer, thus tightening them in the hub. If the wheel is made with staggered spokes, do not pound more on one side than the other, as it will cause the wheel to be out of line. Hammer all spokes alike. ROY E. WILSON.

### It Catches Them

FLY-TRAPS like this are used on the streets of our little burg and about the farm. They are built from two to two and one-half feet in height, and may be made either square or round. The cost of material for construction being about twenty-five or thirty cents. For the foundation, or bottom, if built square, take a block of wood about fifteen inches across, chisel out a circular aperture five inches in diameter, and over this fit down tightly a funnel-shaped piece of wire screen, seven or eight inches in height, with a small opening at the top. Now take four narrow strips of wood or lath, and tack screen securely to this, lapping closely.

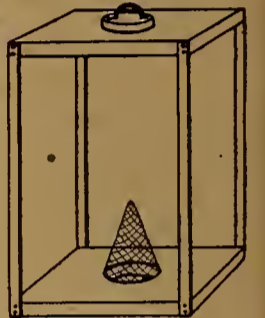

Then fasten this at one end to the block of wood you have in readiness. Nail a similar board, with a like opening but no funnel, on at the other end to form the top of cage. Through this dead flies are removed. A temporary covering may be tacked over it, or you may make a close-fitting lid. Now your trap is ready for use. Place the trap about four inches from the ground by placing a couple of bricks beneath it, one at each side. Put a saucer of thin syrup, to which has been added a tablespoonful of aromatic vinegar, beneath the circular hole at the bottom, and watch them come. They eat and fly upwards, crawl through the top of the funnel, and you have them.

MRS. C. K. TURNER.

### Dry Weather Protection

TO KEEP young plants moist in dry weather, set a pail or other receptacle of water at the edge of the hill, and hang over the edge a rag long enough to reach to the bottom of the pail, and to the roots of the plants. Leave this overnight and it will put the water just where it is needed without wasting any. In the morning take away the pail and lay the rag around the roots. This prevents excessive evaporation. E. C. QUICK.



### Mends the Garden Hose

WISHING very much to use my garden hose which had a bad leak, and not being able to get a regular coupling, I hit upon the idea of making the necessary repairs without one, and which turned out to be as good as the commercial coupling. I cut the hose as true as possible at the point of leak, then inserted a three by one-half inch gas nipple (Fig. 1), after which I painted the joint with good heavy paint. I then took one turn around the hose with bale wire directly over the threads of the nipple (Fig. 2) and with my pliers twisted it up very tight, and after pounding down the ends I bound the whole joint and two inches each side with one-inch muslin strips, painted, and then wound with stout twine. The result is exceedingly satisfactory even under our high water pressure. FRANK E. DRUMM.

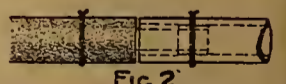
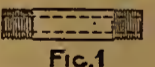

### Winners—July 25, 1911

FARM AND FIRESIDE readers are asked to send in post-card votes, telling which three ideas in each issue they think are best. The ideas receiving the highest number of votes in the July 25th number were:

- A Pure-Water Cistern, by H. F. Grinstead
- Evaporated Fruit Excels, by W. F. Hale
- To Trap the Hawk, by W. K. Shinn

Send in your votes for this page now.

# The WINDMILL

light, heat and power for the remnant of the human race. In the interim, between the beginning and the end (where we now are) it makes a greater return to the people in proportion to its cost than any other machine. It does more cheaply, and with less attention, the thing which it is fitted to do, than any other power.

The wind blows everywhere and is free. With a windmill, the expense for oil and repairs is the only one, and that is trifling. An engine requires much more in the way of oil and repairs, and fuel — which is the great expense — has to be added.

**The windmill does not require an experienced man to operate it.** It is so simple that anyone can understand its workings.

A well-made windmill is a durable machine. The driving shaft of a windmill runs only about one-fifth as fast as the crank shaft of an engine of the same power. A good windmill will outlast several engines doing the same amount of work.

**The best farmers, everywhere, use windmills** generally for pumping water. In every progressive farming community the windmill is the most conspicuous object. It towers above most groups of farm buildings.

All the world knows that the Aermotor Company made the first steel windmills and steel towers, and made the steel windmill and steel tower business. It is believed that, since the business was fairly established, it has made, and continues to make, more than half the world's supply of windmills. In the Aermotor the plan of back-gearing was first introduced into windmill construction. By this means the power of the swiftly running wheel is utilized without operating the pump too fast.

**The peculiar form of Aermotor wheel,** which gives it great power, also enables it to run in the lightest breeze. No windmill has yet been made which equals the Aermotor in its light-running qualities. The form of the wheel is exactly right.

Simplicity is another of the important features of the Aermotor. There are no complicated parts to get out of order. There are no devices requiring skillful adjustment. Every part is solid, substantial and durable.

The main bearings of the Aermotor have large dust-proof oil pockets which afford the best possible means of lubrication. The other bearings have automatic oil cups.

**The Aermotor has thoroughly demonstrated its staying qualities.** In almost any community Aermotors can be found which have been doing duty for fifteen, eighteen or twenty years. And these old Aermotors were made before the days of the heavy gears and the shaft-carrying arms which are easily turned in their sockets so as to give new and perfect bearings for the shafts in case they have become worn through overloading or neglect. The present Aermotors are sure to be more durable and serviceable than the earlier ones.

**The galvanizing of Aermotor outfits** has had much to do with their popularity. Aermotor galvanizing is real galvanizing. It is the best that can be done and will last a lifetime. Aermotors which were galvanized twenty years ago are as good as ever.

**The Aermotor Company has been building for the ages.** It has always been working toward the building up of a great and permanent business. It has succeeded so well that Aermotors are as well known in South America and South Africa as in the United States. Dealers in Aermotor goods are found everywhere. When you want anything in the Aermotor line you can get it and get it quickly.

## AERMOTOR PRICES AND POLICIES

When the Aermotor Company commenced the manufacture of the windmill, it reduced the cost of wind power to one-sixth of what it had been. It advertised its prices. It made the best thing that could be made and at the lowest price at which it could be made. It uses no traveling men. It made so good an article that one-half the world's business came to it and stayed with it. It is doing the same thing with the gasoline engine. Where one goes others follow, and we are

turning them out in great quantities, to the delight of Aermotor friends everywhere. We could send smart traveling salesmen to see you and persuade you to pay \$25 or \$50 more for a windmill or an engine, and it would be worth it—not to you, but to us. But there are plenty of reading and thinking men who prefer to save their own time and money and deal in the Aermotor way.

## AERMOTOR GASOLINE ENGINES

**Wherever a windmill is suitable for the work,** an Aermotor furnishes the cheapest and most satisfactory power for pumping. But there are some places where a good wind exposure cannot be had. There are other places where power is wanted only temporarily. Sometimes tenants are obliged to supply their own power for operating the pump and do not wish to put up a windmill which they will have to leave behind them when they move. To supply the demand for a pumping power for such cases the Aermotor Company makes a gasoline engine which can be attached to "any old pump" in thirty minutes. It is sold complete and ready to connect to the pump for **\$37.50, F. O. B. Chicago.**

For ranch purposes, or for handling large quantities of water, a **heavy, back-gearred pumping engine** is supplied for **\$100.00,** all complete, ready to receive the well fittings, which can be set up in working order within an hour after it is received. It is capable of raising sixty barrels of water an hour to an elevation of one hundred feet.

**For running machinery,** the Aermotor Company makes a line of General Purpose Power Engines. The **2 H. P. Hopper Cooled Engine** sells for **\$75.00, 4 H. P., \$125.00.** All prices are F. O. B. Chicago.

These engines are fitted with the Aermotor **galvanized steel pulleys.** Who ever heard of a **galvanized steel pulley?** No one. Nor did anyone ever hear of a galvanized steel windmill, or steel tower, until the Aermotor Company produced them. These galvanized pulleys are sure to revolutionize the pulley business. They are light, strong, cannot be broken, and are wonderfully cheap. **A complete set of seven pulleys** for a 2 H. P. engine is sold for only **\$8.00.** A set of seven pulleys for the 4 H. P. engine sells for **\$11.90.** We always furnish one pulley free with each power engine; but to anyone thinking of buying an engine, who writes us within one week from the appearance of this advertisement, stating in what paper he saw it, we will furnish free, with each 2 H. P. engine or larger, \$5.00 worth of pulleys of any size which you may select for either engine or line shaft, provided the order is sent in before January 1st, 1912. Pulleys for the line shaft—being used where they are protected from the weather—are not galvanized.

## MAGNETO WITHOUT EXTRA CHARGE

All Aermotor Power Engines are fitted with a **magneto** without extra charge. Batteries are not used with these engines. You have no ignition troubles when you buy Aermotor Gasoline Engines fitted with the Aermotor magneto. We don't believe that anyone who once sees an Aermotor Engine run with magneto will take any other engine as a gift. For full particulars write

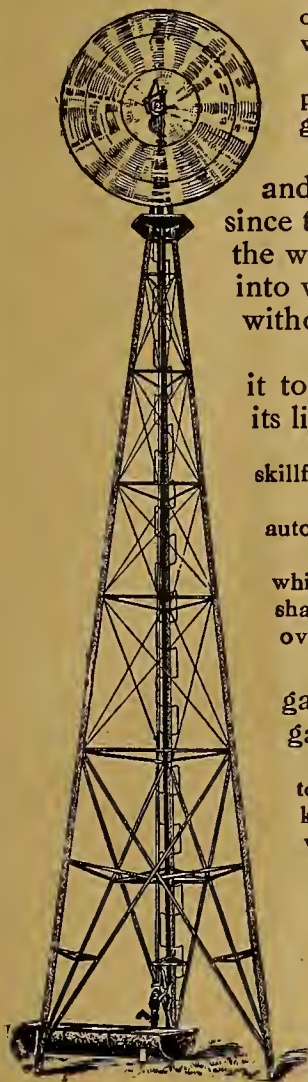
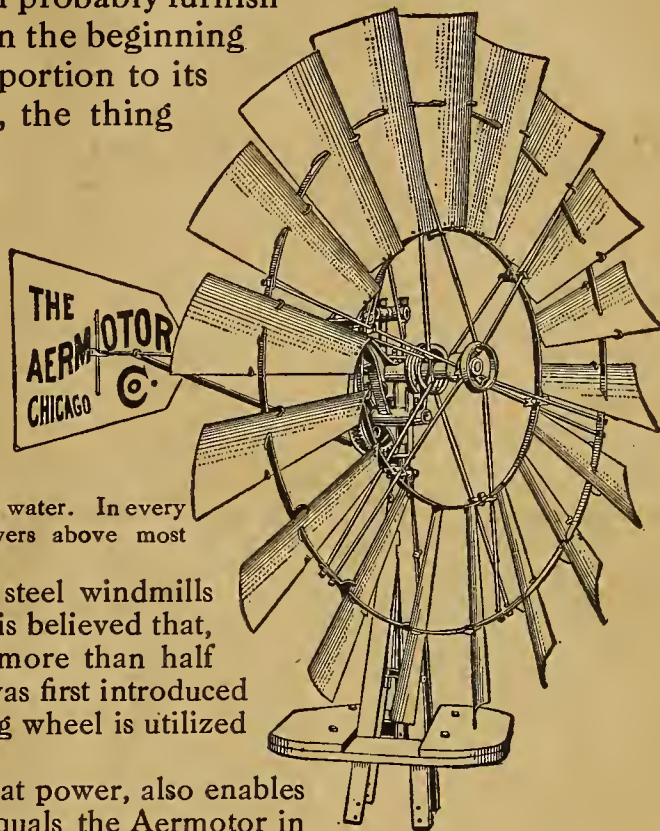

Still Smiling  
The Aermotor has been smiling at the breezes for 23 years

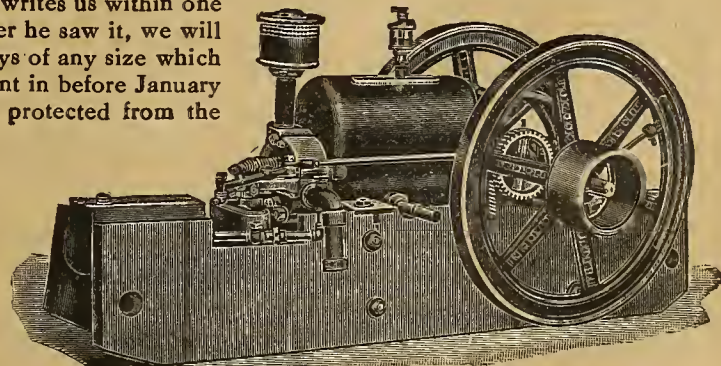
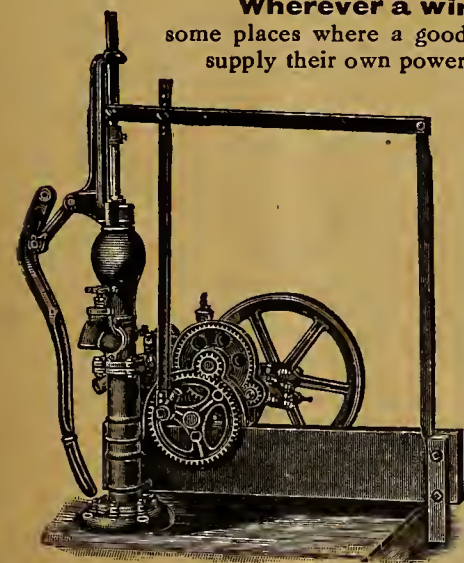

AERMOTOR STEEL PULLEYS

Diameter of Pulley, Inches.	Width of Face, Inches.	PRICES.	
		For Engine	For Line Shaft
6	7	.75	.95
8	9	.85	1.05
10	9	.95	1.20
12	9	1.10	1.40
14	9	1.25	1.60
16	9	1.45	1.80
18	7	1.65	2.10
20	7	1.90	2.40
22	7	2.15	2.70
24	7	2.40	3.00

Compare these prices with those you have to pay for any other pulleys

**Aermotor Company 2516 W. 12th Street Chicago**



N. M. RUTHSTEIN  
The Steel Shoe Man

# Every Step Like Walking On Carpet

I want you to know about my Steel Shoes even if you never buy a pair in your life. The more your feet bother you, the harder you are on shoes, the more I want you to read my free book, "The Sole of Steel." I just want you to know why mud, brush, water, snow, ice, are all alike, all good footing, if you have on a pair of my Steel Shoes. I want to show you why Steel Shoes will cure corns, bunions or callosities if you have them—or how to always keep your feet free of these troubles. I want to show you how over half a million men are each saving about \$20.00 shoe money a year, because Steel Shoes outwear about 6 pairs of leather shoes or rubber boots. Not only that, but I want to prove to you that

## Steel Shoes Protect Your Health

Cold, wet feet lead to lumbago, rheumatism, neuralgia, colds, grippe, bronchitis and even pneumonia. Steel Shoes insure you against all these dangers, because the steel sole comes up one inch all around and is bound to the leather by a riveted, water-tight joint. Your feet are powder-dry in Steel Shoes, perfectly comfortable all the time, winter and summer, and secure against injury from nails, stones and all sharp things that rip through leather or rubber boots. When over 500,000 men will never do another day's work in anything but Steel Shoes if they can help it—isn't it time for you to investigate?

### Write For My Free Book Now

Just a postal will do. It's worth that, surely, to gain health protection, foot comfort and a saving of \$20.00 a year. Then if you decide to try a pair, I'll send them on Free Examination and Try On in your home. I have a size to fit every man—and boy too. Write me now for the book.



N. M. RUTHSTEIN, The Steel Shoe Man  
264 Seventh Street, Racine, Wisconsin  
Canadian Factory: Toronto, Canada  
Great Britain Factory: Northampton, England

## Crops and Soils

### Head off the Real-Estators

By a Field Worker.

THE editorial in the June 10th issue and Mr. Armistead's suggestion of a land expert lead me to point to what should be one of the best possible solutions of the problem of selling new lands. It should be the function of the states to invoice the fertility of their lands, and to take stock of the character of soil. The detailed soil surveys, as being carried out in the states of Wisconsin and Illinois, are gathering a stock of reliable data that will be entirely at the disposal of prospective investors.

Wisconsin, for example, is running both detailed and reconnaissance (less detailed) surveys, aiming to secure an estimate of the value of her soils within a period of about ten years. This survey will then serve as a basis for further field experimentation by the experiment station, and thus there will be added further practical information concerning the possibilities of the different soil types in the state.

Field examination and mapping of the soils will locate the types of soils, describe their topography, examine the character of soil and subsoil, and take account of the native vegetation found growing, as well as of the present condition of cultivated crops, where the survey is being made in a settled area.

Laboratory examination of the soils will determine the amount of plant-food in the soil, the phosphorus, the nitrogen, the potassium. The amount of vegetable matter in the soils will also be determined. Soils will be tested for acidity, and if acid, a determination of the amount of lime necessary to neutralize them will be made. In case of soils not acid, the soil will be analyzed for

the amount of carbonate of lime or magnesium that it contains, in order that knowledge may be obtained of the length of time that one may expect such soils to remain neutral. Physical examination of the soils will determine the relative proportion of sand, silt and clay particles, in order that exact knowledge of the workability of the soil may be had, and so that the movement of water in the soil may be predicted, and its water-holding power estimated.

Hand in hand with field and laboratory examination of soils should go supplementary experimentation. Coupled with these there should be compiled the necessary meteorological data, such as the amount of rainfall, its distribution, the time of first autumn and last spring frosts, and the amount of sunshine and its distribution throughout the season.

Where such information is available, the common-sense investor will use it intelligently, and will thus avoid pitfalls laid for him by the real-estate boomers.

H. L. WALSTER.

### Seed-Corn Record

THE farm papers over the country have written a great deal about selecting and storing seed-corn. Under my conditions there are some methods which seem to do best. We are in Illinois, the heart of the corn belt. Our seed-corn is gathered all the way from September to December. I prefer to gather the corn from the stalks as they are standing in the field, but we are often required to gather the seed while cutting the general crop. I place a box on the harvester, and when I find a vigorous stalk and a well-developed ear, I save it by placing it in this box. When we gather the stalk-corn, the box is fastened to the wagon-bed to catch any good ears yet remaining.

In hanging the corn, I take a string six or eight feet long, and tie an ear in the middle of the string. I hold that ear between my feet, place another on top, tie it with a single knot and keep this up until the string is full. The corn is then hung to rafters in the barn or in any good outbuilding where the air can get to it, providing the mice and rats are not bad there. I use number nine wire and extend it from rafter to rafter. A piece of tin about six inches square, with a hole in the center through which the wire passes, is placed on the rafter to keep mice away. Each string of corn is hung to this wire far enough apart so that the ears do not touch. Each ear is tagged and numbered for testing in the spring.

Another method of hanging the corn is along the sides of the crib, or in some protected place of an old wagon-shed, by simply putting nails every now and then along the sides of the wall.

It has been my experience that no corn will freeze, providing it gets plenty of air. We formerly lived in northwestern Illinois, where the thermometer frequently registered as low as twenty degrees below zero. Our corn was good and we always had a fine stand. The principle is to select the corn and hang it up before the time of freezing.

Our general rules might be stated as follows: First, to secure well-developed, large ears; second, to gather early; third, to place or hang in cool, dry quarters; fourth, to see that no two ears touch; fifth, to see that the corn is kept from all moisture and snow. These rules, coupled with the fact that all of the corn is tested each year, have given us success for the past twenty-five years.

D. L. COVER.

### Value of Sweet Clover

A KENTUCKY subscriber sends a specimen of "weed" which flourishes on the very poorest soil on his farm. Stock refused to eat it. He asks whether its growth will improve the land.

The weed, as would be expected by the initiated, is sweet clover (*Melilotus Alba*). Stock have to learn to like sweet clover, as many people have to learn to like onions. When kept pastured or clipped close, the young growth is soon relished by cattle and hogs, some experienced growers claim, others hold the reverse opinions. Still others say that when cut when the first blossoms appear stock relish it as hay. Sweet clover unquestionably is a nutritious feed and one of the best soil-renovators to be found, since it will grow on very impoverished soil, fixes free nitrogen and ramifies the soil deeply, growing when drought shrinks plants less lustrous.

B. F. W. T.

### Sow a Patch of Rye

TO HAVE a patch of rye that will furnish a late fall and again early spring feed would be a great help on every farm. In the fall it furnishes its greatest value, perhaps, with sows and fall pigs, where a little green feed is relished greatly and will help immensely in starting them into the winter in a thriving condition. Last year we sowed a patch of it early in September. It was green for some time after all other pastures had dried up. In the spring it made such a rapid start that it was ready to be pastured several weeks before the regular pastures had made a good start. In this way rye can be used as a catch or extra crop. It can be sown on a stubble-field that is not to be cropped

# 125,000 Opportunities to Save Money

Save every cent you can. The total will be worth while. We carry in stock more than 125,000 articles of every day use. On every item in this tremendous stock you are offered a saving that ranges from 20 to 50 per cent. So we offer you your choice of 125,000 separate and distinct opportunities to save money. We secure the lowest possible prices by buying in great quantities. The prices you pay us are a very slight advance over those we pay. Every article we sell is of the best quality—the biggest value. We guarantee that every purchase will be satisfactory. Return any article that is not. We will pay transportation charges both ways and return your money or make any exchange that is fair. Start saving NOW. Tear out the coupon and check the books you want. Mail it to us.

**\$4.68**  
**Buy This Chair**

This chair is a large, comfortable, upholstered rocker for the sitting room. It is covered with black imitation leather and is 40 inches high and 25 inches wide. It will be an ornament in your home and will give long service. This is just one out of the many hundred furniture bargains we offer. We buy the entire output of furniture factories. We know that our furniture is made of best materials and by expert workmen because we superintend every detail. We know our prices are the lowest because we ask only a slight advance over the manufacturing cost. You save 50c on the dollar.

Send for our new furniture book, book No. 7, to-day. You will get it by return mail. Look into this plan for securing at rock bottom prices, the best furniture that is made.

**Stoves and Ranges at a Saving of 1-2**

Perfect stoves, perfect ranges are the only kind we sell. We know they are perfect in every way because we control the output of stove foundries. Thus we can inspect every piece of material that goes into the making of them. We buy these stoves and ranges in solid trainloads at prices that are hardly more than the cost of manufacture. We guarantee our stoves or ranges to reach you in perfect condition. You will find real stove and range bargains in our special stove book. Every stove or range is of the best quality. You will save from 40 to 50 cents out of every dollar that you will be asked to pay elsewhere. Send for Book No. 23.

**\$3.95 TO \$9.29**

**Buy Your Groceries at Wholesale Prices**

Economize on your grocery bills, but do it in the right way. Here is a chance to get just the same amount of food—or more, and just the same quality of food—or better, for less money than you have been paying. Our grocery department is complete in every particular. In every article we give full weight and full value. We make many articles ourselves so that we can be certain they will be pure. The prices we ask are really 50 per cent lower than those you have been paying the local dealer.

**New Grocery List Every 2 Months**

It is not going to cost you anything to write to us and tell us to put your name on the list to receive our special grocery catalogue every two months. Just send to us today for Book No. 11; we will put your name on our regular mailing list to receive the grocery list every two months.

**Buy Guaranteed Roofing and Save 1/2**

You can forget that you have a roof if it is protected with our guaranteed roofing. Just send for Book No. 5. Compare the prices for yourself. You will see that you can save just 1/2.

Remember, you are taking no chances because we guarantee the roofing for periods of 10, 12 and 15 years, depending upon the quality you buy.

**READ THESE CAREFULLY**

**Fall and Winter Necessities at Big Savings**

**Check the Book You Want**

Let us show you, free of all cost, how you can save money on everything you buy to eat or wear or use in any way.

**Montgomery Ward & Co.**  
19th and Campbell Sts. Chicago Avenue Bridge  
KANSAS CITY CHICAGO

Please send to my address below the books I have checked absolutely free of cost.

1 Paints	19 Sewing Machines
2 Pianos	20 Gasoline Engines
3 Organs	21 Cream Separators
4 Trunks	22 Building Material
5 Roofing	23 Stoves and Ranges
6 Vehicles	24 Underwear Samples
7 Furniture	25 Automobile Supplies
8 Incubators	26 Bicycles—Motorcycles
9 Wall Paper	27 Baby's Dress and Toilet
10 Typewriters	28 Women's Tailored Suits
11 Grocery List	29 Circular and Drag Saw
12 Feed Cookers	30 Women's Fashion Book
13 Tank Heaters	31 Rain Coats, Rubber Coats, etc.
14 Wire Fencing	32 Tombstones, and Monuments
15 Carpets, Rugs	33 Men's Clothing
16 Building Plans	34 Women's Furs
17 Baby Carriages	
18 Men's Fur Coats	

Name.....  
Post Office.....  
State.....  
Send Coupon to the Nearest Address.

**Two New Clothing Books**

Save 1-2 on Your Fall and Winter Clothing

Dress comfortably and stylishly this winter at half the usual cost. Provide yourself with clothes made of the latest and best fabrics and perfectly tailored by experts.

In two special books we offer you the opportunity to do this. They are the "Women's Fall and Winter Fashions" and "Men's Fall and Winter Clothing."

We know that our clothes are made of the best fabrics and from the latest designs because the manager of our tailoring division keeps closely in touch with the leading fashion centers of the world. He selects those fabrics and designs which he knows to be the best.

We know that our prices are lower than you would pay elsewhere for the same excellent quality of clothes we sell because we buy the clothes in great quantities. We get right down to the rock bottom prices at which clothes can be bought. Then we ask but a slight advance over these in the prices we ask you to pay.

Get an early start and have your selections made before the fall and winter season is upon you. Send for the book you want—women's fashion book is No. 30, men's book is No. 33—and make your choice without delay.

**MONTGOMERY WARD & CO.**  
19th and Campbell Sts., Kansas City  
Chicago Avenue Bridge, CHICAGO

regularly until the next season. Thus the rye can be pastured in the fall and again in the early spring and then the field be made use of for some other crops if desired.

Unused lots and patches of ground can often be made use of to very good advantage in this way. A big barn-lot sown early to rye makes splendid feed for the calves when they are being weaned or when brought in for winter. We once seeded a potato-patch in the fall after that manner. It was near the chicken-yard and made the best early chicken forage we ever had.

H. E. McCARTNEY.

### Cutting Corn

Most writers talk about cutting corn and they have in mind level land where corn can be worked both ways. None of these plans suit the farmers on our West Virginia hills. Only on the river and creek bottoms do we work our corn one way. Sometimes one row is a foot above the other on a hill-side. In cutting we follow this plan:

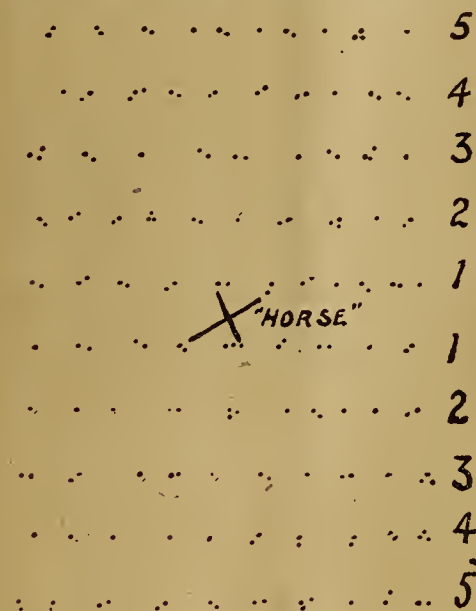

You will notice that the number of hills in a ten-hill square shock will vary from nine to eleven to the row. The shock here represented will contain 101 hills, or 202 stalks, if the corn has been properly thinned. The next one may not contain more than ninety-seven or ninety-eight. It will average one hundred hills to the shock. Any other sized shock will average up nicely.

If I am alone, I tie my "horse" five hills from the end. I begin row number one at the "horse," cut to the end and back to the "horse" on number two. The corn will be very heavy if an ordinary man cannot carry eight hills. If too heavy, I go to end of numbers one and two and cut toward the shock as far as I can. That is on the other side of shock on the lower side of shock-row. Then likewise on upper side, and then I tie my "heart." Across ends of number five, four and three toward the shock all that can be conveniently carried is cut. I always try to set the corn as evenly around the shock as possible.

W. T. SMITH.

### Balancing Your Crop's Rations

Even if good crops are raised, it is not good farming to grow grain year after year till those who tell us that the fertility of our soils is inexhaustible are proven false prophets. Since nitrogen, phosphoric acid and potash are found in all grain, each crop we raise takes these three elements from the soil in large quantities. Now the question for every crop grower to answer is this: "How are we to replace them in sufficient quantities to increase the fertility of the soil and at the same time sell a large per cent. of all the grain we raise?"

Stable manure when properly applied goes a long way toward "filling the bill," but stable manure is not a perfectly balanced manure, since it does not contain enough phosphoric acid.

"What's that?" you say. "Do you mean to tell us that after figuring out how to balance our farm accounts and our feeding rations that we must learn to balance our stable manure?" That's just the point. Stable manure is a good fertilizer, but it does not contain fertilizing elements in the proportion required, by growing plants. Manure is a food for plants just as grasses and grains are food for animals and to get the best results your plant rations should be balanced in the same manner as your feed for live stock.

The Ohio Experiment Station has proven that by the addition of forty pounds of phosphoric acid to each ton of stable manure the value of the latter as a crop-producer is nearly doubled.

By the growing of clover and other leguminous crops, we can store up in the soil large amounts of nitrogen from the air (of which there are many millions of pounds above each acre), but phosphoric acid and potash cannot be so easily supplied.

The use of commercial fertilizers is a necessity to good farming as any one or more of the three elements can be partially supplied by its use. But every wide-awake farmer has learned either by his own experience or by that of others that the application of a couple of hundredweight of commercial fertilizer will not "fill the bill."

Many so-called "complete commercial fertilizers" will analyze about two per cent. nitrogen, eight per cent. phosphoric acid and two per cent. potash. Two hundred pounds of this compound spread over an acre would contain four pounds of nitrogen, sixteen of phosphoric acid and four of potash. Now each good crop of grain removes from the soil many multiples of that amount. It is estimated that seventy-five bushels of corn together with the stalks will remove ninety pounds of nitrogen, twenty-five pounds of phosphoric acid and seventy-five of potash, so that the commercial fertilizer cited above would be equivalent to about a one-tenth ration for an army making forced marches or a diet of thin soup for an active growing lad.

Hay, straw and corn-stalks take up from the soil more potash than the grain, but in ordinary practice these are used up on the farm and returned to the soil. Where the soil seems to be nearly worn out, complete commercial fertilizers are needed, but their continued use when not accompanied by clover or stable manure will leave the land in a poorer state than at first.

Stable manure is the foundation for all really effective soil-building fertilizers. Enough stock should be kept to work up all straw with the manure and to eat all hay and corn-stalks. Of course, a liberal amount of grain must also be fed to keep up the scheme of keeping both the animals and crops on balanced rations.

Clover alone, stable manure alone, commercial fertilizers alone or the rotation of crops alone will not be sufficient to feed farm crops sufficiently, but each and all should be used with judgment. In this manner we can increase the fertility of the soil and at the same time sell a large per cent. of all the grain we raise.

E. H. K.

### Winter Oats

A subscriber in eastern New York is interested in winter oats. Spring oats fail frequently on account of dry weather in his section, when other crops are successful. How do they compare with spring oats in yield and time of ripening?

Winter oats are still in the experimental stage. The Ohio Experiment Station, during several years' experimental growing, found that winter oats exceeded the spring varieties in weight 3.08 pounds per bushel and in a three-years' average yielded 56.56 bushels per acre, while the average for the spring varieties during the same period was 51.60 bushels per acre. Experiments conducted by the Kansas Experiment Station in 1904 with winter oats furnished only successful results with one variety, "Winter Turf," which yielded 57.37 bushels per acre. These oats matured a little later than the average of the spring-sown oats. Experimental growing of winter oats indicates the need of trying them out on a small scale at the start.

B. F. W. T.

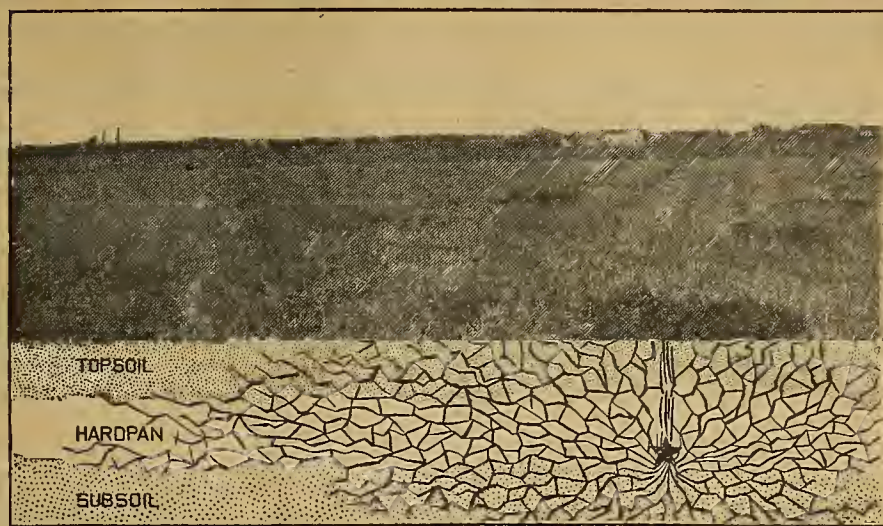

## Drouth Problem Solved

WITH



## RED CROSS DYNAMITE

The ample rains of fall, winter and early spring may be drawn on all summer by storing them in subsoil. This is made possible by dynamiting the compact subsoil or hardpan, thus creating a water reservoir and making available fresh nitrogen, phosphorous, calcium and other fertilizing elements now useless. *October is the time to subsoil.*

### Write for Free Booklet

To learn how progressive farmers are using dynamite for removing stumps and boulders, planting and cultivating fruit trees, regenerating barren soil, ditching, draining, excavating and road-making, ask for "Farming With Dynamite, No. 90."

### E. I. DU PONT DE NEMOURS POWDER CO.

PIONEER POWDER MAKERS OF AMERICA

ESTABLISHED 1802

WILMINGTON, DEL., U. S. A.

Store-keepers wanted in every town and village to take and forward orders for dynamite and blasting supplies. Not necessary to carry stock. Large sale possibilities. Write at once for our Dealer's Proposition. DU PONT POWDER CO., DEPT. 90, WILMINGTON, DEL.

PATENTS SECURED OR FEE RETURNED. Free report as to patentability. Illustrated Guide Book, and List of Inventions Wanted, sent free. VICTOR J. EVANS & CO., WASHINGTON, D. C.

PATENT SECURED OR FEE RETURNED. Free Patent Book, Selling Guide and List of Buyers and Manufacturers of Inventions. Advice Free. Send sketch. FARNHAM & SUES, Attys., 562 F. St., Washington, D. C.

# "Pittsburgh Perfect"

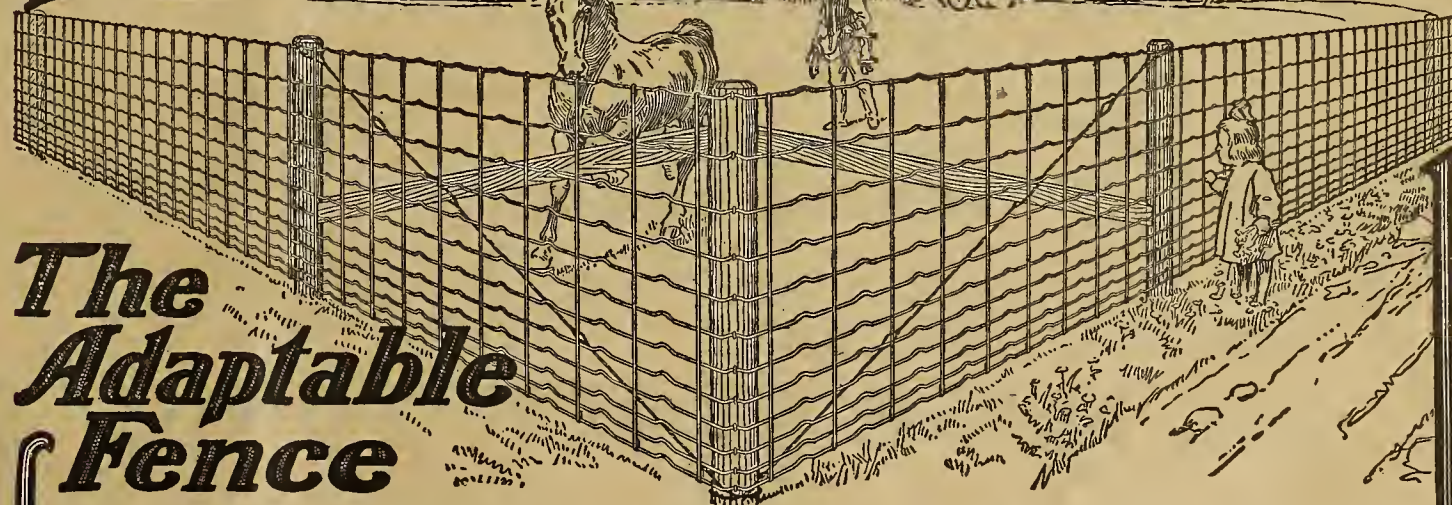

## The Adaptable Fence

AMONG the 145 styles and sizes of "Pittsburgh Perfect" Fence shown in our new catalogue, the fence user can now obtain fencing perfectly suited to his particular requirements. "Pittsburgh Perfect" is the most adaptable, portable, durable and resultful of all wire fences, and gives absolute satisfaction because, coupled with our ripened manufacturing experience, it is the culmination of close and exhaustive study and investigation of farmers' needs along lines of up-to-date agricultural methods and equipment.

Open Hearth Wire, like old time iron wire, is used exclusively in "Pittsburgh Perfect" Fence, and is galvanized with a thorough and even coating of pure zinc, which resists rust for the longest time. All line and stay wires are ELECTRICALLY WELDED at every contact point, producing a perfect amalgamation of metals, and doubling the strength of the fence at the joints. This feature is found only in "Pittsburgh Perfect" Fence, and makes it unequalled for toughness, strength, and economy in weight and price.

**Every Rod Guaranteed Perfect** OUR NEW CATALOGUE contains valuable information about wire fencing, and illustrates styles and sizes adapted to every FIELD, FARM, RANCH, LAWN and POULTRY purpose. Write for it now, and then look up the best dealer in your town—he handles "Pittsburgh Perfect" Fence exclusively.

### PITTSBURGH STEEL CO., PITTSBURGH, PA.

MANUFACTURERS OF—"Pittsburgh Perfect" Brands of Barbed Wire, Bright, Annealed and Galvanized Wire, Fence Staples, Standard Wire Nails, and "Pittsburgh Perfect" Fencing, all made of Open Hearth material



## DON'T BUY A GASOLINE ENGINE

Until You Investigate The Temple Make. Its Great Advantages are: 1st—Lowest Fuel Cost; pays for itself in Fuel Saving. 2nd—Delivers Steadiest Power Stream, adapting it especially for operating farm machinery. 3rd—Easy on the machine it operates. 4th—Uses Gasoline, Kerosene or Gas. 5th—Perfect Lubrication. 6th—Starts Easily and Quickly, occupying minimum space. 7th—It is the King of Portable Engines. No engine has so wide a range of use. YOU WILL MAKE A MISTAKE IF YOU DO NOT WRITE FOR INFORMATION. We make 1 1/2 to 5 1/2 H. P. single cylinder engines; 6 to 20 H. P. two cylinder engines; 30 to 50 H. P. four cylinder engines. All Heavy duty, slow speed engines. For surety of operation and low fuel cost our engines lead. TEMPLE PUMP COMPANY, Manufacturers. 419 West 15th St., Chicago, U. S. A. This is our 59th year.



## Farms in Golden California on half-crop-payment plan

Greater wealth is coming from California's farms than from her gold mines.

Here is an opportunity for you:

California needs more farmers. The San Joaquin Valley, on the line of the Santa Fe, has about 40,000 farms developed where there is room for nearly 400,000.

Many of the farmers who are getting rich there now are from the East. Some, perhaps, are old friends and neighbors of yours. Fill out the coupon below and let us send you the hook, which contains letters from many prosperous farmers who are gathering the treasures which this wonderful valley produces so abundantly.

The San Joaquin Valley of California is the heart of that rich and fertile "Land of Sunshine." It is 250 miles long and 100 miles wide. The Santa Fe Railway extends the entire length and is anxious to see the country developed as it should be. The railway has no land to sell. The Colonization Department is merely to let people know about the opportunities for success afforded by the country.

We will tell you the truth about what people are doing in this wonderful valley. We will point out the lands for sale. We will tell you about going there. If we have not the particular information you want about the country, we will get it for you.

Successful farmers of the San Joaquin Valley say "every acre should produce one hundred dollars or more annually."

It is mostly irrigated land, and the farms are from ten to eighty acres. Many times that acreage would be necessary "back East" to yield the returns that come from these "little farms."

A little truck, some chickens, a cow or two, pigs and alfalfa, make a good living for the family until fruit and other money-making crops are matured.

Raw land is cheap. A few years of intelligent cultivation under irrigation and the wonderful crops produced make it very valuable.

Something grows all the time in the San Joaquin. Oranges, lemon, grape fruit begin to ripen in November, and one fruit follows another all winter. Small fruits ripen early in the spring. Prunes and apricots come in June and July, melons and figs from July to November. Alfalfa is cut every two or three months. It is worth \$8.00 to \$18.00 a ton and yields from four to seven tons an acre.

It is a fine climate to live in. Winter like June and cool nights, even in summer. Then it may be

100 degrees in the middle of the day but the air is clear and dry, and even if it is a little warm everybody wants warm weather then to ripen summer fruits.

### An Extraordinary Proposition

A limited number of very desirable 40 acre farms in one of the hanner counties of this wonderful valley can be secured by farmers who act quickly, on a very liberal half-crop-payment plan.

Only a small first payment is required and the balance of the price is to be met by one-half of the gross income from 35 acres until paid in full. Interest on the deferred payments is only 5 per cent.

Do you know anywhere that you could buy on more favorable terms? Or in a finer country than this San Joaquin Valley?

A special circular explains the plan in full. You had better get it and read it if you really want a farm.

We will also place your name on our list so that you receive free each month a copy of our immigration journal, "The Earth," which gives up to date information about all of the country along the Santa Fe, including the San Joaquin Valley.

Railroad fares are low now. Only \$33 from Chicago to California September 15th to October 15th with proportionate rates from other points. Santa Fe tourist sleeping cars are comfortable. Berths cost only about half the usual Pullman rates. You can see the country now at small expense.

You owe it to yourself to learn of the opportunities Golden California offers farmers, so fill out the coupon now, enclose it and mail to this address:

G. L. SEAGRAVES,  
General Colonization Agent, A. T. & S. F. Ry.,  
2251 Railway Exchange, Chicago.

Please send me information about San Joaquin Valley and half-crop-payment plan.

Name .....

Address .....

### HARVEY BOLSTER SPRINGS

Soon save their cost. Make every wagon a spring wagon, therefore fruit, vegetables, eggs, etc., bring more money. Ask for special proposition. Harvey Spring Co., 729-17th St., Racine, Wis.



GUARANTEED

### ONLY \$10. CASH

Balance \$5 a month, buys this three-year GUARANTEED Buggy. Write today for our FREE CATALOGUE of Buggies, Surreys, Spring and Farm Wagons. Century Mfg. Co., Dept. 628 East St. Louis, Ill.



Catalogue Free.

## Live Stock and Dairy

### The Trick of Marketing Hogs

THE proper time to market hogs is a question that is usually given insufficient consideration by the average grower. He looks only at the low cost of production and the placing of the fattening period at a convenient time. These are practical problems that should never be overlooked, but they are only a part of the whole question. When one keeps track of the market prices, he learns that there is a somewhat regular rise and fall at different seasons. At the beginning of the year the prices are at the low figures because the hogs fattened on new corn are going to market by the train-load. As spring comes on the feeding-yards are pretty well cleaned up and field work demands the farmer's time, consequently the lessened supply starts the prices climbing, which they continue to do until the high point of the year is reached about harvest-time. Then with the appearance of the first of the winter and early spring hogs the market weakens and the price continues to fall as the late fall and winter marketing continues.

The method usually followed is to run the spring crop of pigs on pasture during the summer, fatten on new corn and sell in the winter. In this way cheap corn is fed, there is plenty on hand and the additional chores come when the field work has let up. Thus the profits obtained are in proportion to the work, for the hogs are marketed during the winter.

How often do you hear a farmer say, "When we have heavy hogs, the packers want light ones, and when we have light hogs, they want heavy ones." To be sure, this is true and always will be, for when the farmers have heavy hogs, there is consequently a shortage of light weight and so they sell at a premium, and vice versa.

The trick is to produce that which every farmer does not have and so supply the market with the class that is selling at a premium. This is the key to success in all business: To produce that which sells at an advanced value, because of the short supply. This may be done with hogs by having the spring pigs come early and fattening them at the earliest possible time in the fall, thus getting them to market before prices are much below their high summer level. In this case field fattening is very satisfactory, except in a rainy fall, and the gleanings can be picked up after they have gone to market by the fall pigs or by sheep.

The growing of fall pigs which are really for market the following summer usually proves a financial success. During the early winter months they can be allowed to save the waste of the field fattener mentioned above, and as soon as rye and clover are ready in the spring they can be pastured on it and fattened before hot weather arrives. It is natural for an animal to grow rapidly with the arrival of warm weather and it is sometimes astonishing the growth the fall pigs will make at this time.

It would seem that if more hog-raisers would watch the market and plan to hit the

high spots, their time would be well spent and the markets would be on a firmer, steadier foundation. However, it is not well to gamble with the market, but to have ready a hog of the right weight when the period of high prices regularly comes and to sell it when it is ready, regardless of the price of the day. LLOYD K. BROWN, South Dakota.

If you allow a cobbler of a blacksmith to shoe your horses, you need not be surprised if the animal has hoof and foot troubles, brought on by improper shoeing.

### Pasturing the Highway

STOCK running loose on a highway much frequented is a forlorn nuisance not only to the neighbors along the road, but to people in vehicles. Of course, there is a law against such things, but people in the country, as well as drivers of vehicles, are patient and long-suffering, so they patiently endure the trouble. Especially does trouble multiply when a mare and a two or three days' old colt are turned loose to forage along the road, for young colts have less sense even than pigs, according to the majority of drivers. A mare and a colt will get in front of a buggy and go until exhausted, finally galloping up on a neighbor's lawn or tearing down a side road at full speed, doing great damage to both animals, but still people will turn them out without a watcher to care for them.

However, where it can be done conveniently, pasturing the highway has many things to commend it. In the first place, the grass is kept down and saved, an important consideration when pasture is low, and then it gives the stock a change which is very beneficial. Every farmer knows that stock like a chance to forage in new pas-



If the conditions are right, there is no reason why any grass should go to waste along the country highway

tures quite as much as human beings like change, and the pasture along the roadside furnishes almost an extra field if judiciously used. Then, too, it keeps down the weeds, for sheep like weeds better than grass, and the old complaint about the roadside seeding the fields is done away with where farmers graze the sides of the road and keep everything down trim and neat.

The very best time to use this pasture is in the early morning. If the small boys of the family can take the stock out an hour or two before vehicles are passing back and forth, especially after a night spent in the barn-lot or on poor pasture, the benefit will be quickly seen. The instant the cows begin chasing about and get restless they should be returned to the barn-lot or fenced pasture, as nothing is gained by leaving restless animals out to do damage. When they are filled up, turn them back and they will hunt the brook or some cool place to rest until hunger again sends them out to eat. Two quiet hours in the early morning are worth much to the farmer whose pasture is running low, and that amount of roadside feeding does not completely destroy the grass there.

Often neighbors combine, putting sheep out with cattle or cattle with horses, and the children can then play in their own yards and merely watch one end of the long pasture. It is tedious work sitting along the roadside watching cows eat, but if two or three boys combine, it is great fun. When the stock is to be separated, a little salt or a supply of clear, cold water will get each flock to its proper place with little trouble, and if any of the animals are contrary or vicious, they may be left in the fenced pasture. Unsafe animals should never be allowed to run on the highway. In fact, unsafe stock should not be kept anywhere, as a small money loss in getting rid of such animals is not to be thought of in comparison with the danger to the family from such creatures.

If the roadside fences are secure and the stock quiet and the opportune time taken for the task, there is no reason why any grass should go to waste along the country highways. If it does dry and become thick and matted, a spark from an engine, a fire started by boys or campers, a cigar carelessly disposed of or any one of a dozen other methods may make it one long trail of fire and smoke to destroy fences and buildings and crops in late summer. And even when

## Stop Using Feed For Fertilizer

Whole corn in your animals' droppings indicates that a part of the feed of even a healthy animal is wasted through non-digestion. Grinding the feed fails to save this waste, and the feeder must either let his hogs follow up the steers and eat this wasted grain or be content to realize what little he can from it as fertilizer. Saving a part of this wasted feed by *Improving Digestion* is known as "The Dr. Hess Idea," and back of it are the opinions of our ablest writers.

## DR. HESS STOCK TONIC

the prescription of Dr. Hess (M. D., D. V. S.), improves digestion; it contains iron, the greatest of all blood and tissue builders, acts mildly on the kidneys, regulates the bowels, also expels worms and relieves the minor stock ailments. As proof that Dr. Hess Stock Tonic does all these things just show the formula on the label to your family physician. A poor ration well digested is better than a good ration poorly digested. Improved digestion insures more growth, more and richer milk.

**Our proposition.** You get of your dealer a 25 lb. pail of Dr. Hess Stock Tonic at \$1.60, or 100 lbs. at \$5.00 (except in Canada and extreme West and South). Use it all winter and spring. If it doesn't pay you and pay you well, get your money back. Every pound sold on this guarantee. If your dealer can't supply you, we will.

Free from the 1st to the 10th of each month—Dr. Hess (M. D., D. V. S.) will prescribe for your ailing animals. % page Veterinary Book free for the asking. Mention this paper and include 2c stamp.

DR. HESS & CLARK  
Ashland, Ohio



**DR. HESS POULTRY PAN-A-CE-A.** A scientific fowl tonic, prepared by Dr. Hess to make hens lay more eggs. It acts beneficially on the digestive organs, keeps the egg organisms active, contains nitrates to drive out poisons, and iron to build up the system. It fattens broilers quickly, helps chicks to maturity, cures minor fowl ailments. Very economical—a penny's worth feeds 30 fowls per day.

1 1/2 lbs. 25c; mail or express 40c. 5 lbs. 60c; 12 lbs. \$1.25; 25 lb. pail \$2.50.

(Except in Canada and the Extreme West and South.)

## INSTANT LOUSE KILLER KILLS LICE

# Under The Reading Lamp

**N**OW that fall is coming on and the evenings are getting longer the family is eager for some good reading. An abundance can be furnished by the publishers of FARM AND FIRESIDE. Read this column and send in your order at once.

The owners of FARM AND FIRESIDE publish two other periodicals which are the leaders in their respective fields. These periodicals are WOMAN'S HOME COMPANION and THE AMERICAN MAGAZINE.

**W**OMAN'S HOME COMPANION is a big and beautiful periodical having three quarters of a million circulation. It contains stories, articles and illustrations of the highest quality, but it also contains the most valuable household, dressmaking and cooking suggestions anywhere published in the world. These suggestions, which are free to every subscriber, will save time and save money for women in FARM AND FIRESIDE homes.

In addition, WOMAN'S HOME COMPANION buys the good housekeeping ideas of its women readers and pays for them in cash. There are three departments to which women may contribute little items of housekeeping news and suggestions. A regular price is paid for acceptable paragraphs, and in addition several cash prizes are offered every month for the best contributions. In the last twelve months 674 women readers have sold their ideas to the COMPANION.

**T**HE AMERICAN MAGAZINE has a program for this fall and winter that is absolutely unparalleled in interest and importance. There will be two great serials—one of fact and one of fiction—each of which will be brought out later in book form and sold for more than the cost of a whole year's subscription to THE AMERICAN MAGAZINE.

The first of these serials—the fact serial—is by "the most conspicuous senator of his time," La Follette of Wisconsin; a great true narrative of politics. It was announced in FARM AND FIRESIDE for August 25th (see that announcement).

The second great serial in THE AMERICAN MAGAZINE this year—the fiction serial—is a new novel by H. G. Wells who is conceded by all authorities to be the greatest novelist now living. This new story, entitled "Marriage," is the most interesting and powerful of Wells' creations. It is a story of an extravagant wife and a burdened husband, and tells how they met the problem of strained relations—a novel that no reader in the United States can afford to miss.

These two great features in THE AMERICAN MAGAZINE are in addition to scores of great short stories, dozens of notable articles, four original departments and hundreds of beautiful illustrations.

The regular price of THE AMERICAN MAGAZINE is \$1.50 a year, and WOMAN'S HOME COMPANION sells for the same, but to readers of FARM AND FIRESIDE a special price of \$2.20 is made for the two—a saving of 80 cents.

## THE CROWELL PUBLISHING COMPANY

Springfield, Ohio

farmers mow down the grass and weeds with a mowing-machine, they seldom rake and burn the dead and dusty stuff, but allow it to lie on the ground to furnish a winter retreat for rabbits. And no man can cut the grass right up to the fence as stock can eat it. It all depends upon the man and his regard for the rights of others whether the pastured highway means comfort or trouble to the neighborhood. And that may be said of most of the country problems that lie outside the farms and concern every farmer so much. There are men who have pastured the highway for years without trouble for anybody, and their farms are good for the community. MRS. W. C. KOHLER.

### What Stock Pays Best?

**T**HERE are men who are making failures. There are those who are successful. And there is no field in which both of these classes appear in stronger light than on the farm. What is the profit coming from the various classes of live stock raised? Is there as much money in poultry as in hogs? Do cattle produce as good returns as sheep? How may these different kinds of live stock bring most profitable returns? These questions and many others like them will be discussed in the next issue of FARM AND FIRESIDE, by men who know their subjects. Look for the issue of September 25th.

### Outlook on the Sheep Market

**S**OME remarks of a prominent business man, Mr. B. F. Yoakum, president of the St. Louis and San Francisco Railway, made in an address in Texas last week, refer to what he regards as a blot on our farm management, and are worth quoting. He said in part: "The farmer receives but forty-six cents out of every dollar's worth of his produce. Last year's agricultural products were worth nine billions of dollars; assuming that the farmer kept one third for his own use, and that the consumer paid thirteen billions of dollars for what he bought, the cost of realization to the farmers would be seven billions." Imagine what would be the position of the stock-yards, the steel or the Standard Oil magnates if their business were conducted on such a footing, and theirs is but a flea-bite compared with that of all the farmers of the country. He went on to say that, "During the last twenty-five years, commercial exports have increased four hundred per cent., while those of farm products but sixty." He imputes this to the apathy and want of system of the farmers on the marketing end of their business.

I hope to be able to consider this subject more fully in the future. Just now we are concerned with the state of the sheep trade which, I think, has been somewhat affected by this want of business foresight.

Mention has already been made in a former paper of some of the causes of the recent depression, but in spite of the danger of some repetition it may be worth while to consider them more fully.

Eight years or so of good prices led feeders all over the country to buy lambs almost regardless of cost, and to increase their feeding facilities.

The same considerations induced many men of little or no experience in the business to venture into it.

To meet the increased demand, range breeders increased their output of lambs, and steadily raised, and held to, their prices.

Then came the drought; the scorched pastures; the high prices of hay and feedstuffs; the refusal of many of the country bankers to continue the loans by which much of this feeding business was being financed; the uncertainty as to the reciprocity treaty, and as to the wool tariff, and hence a feeling of approaching panic.

From these causes for the most part sprang up the flooding of the market with green and half-fit sheep and lambs. The number of these sent to six of the principal western markets during the first eight months of this year exceeded that of the corresponding period of 1910 by over two millions.

Had even a moderate percentage of this mutton and reputed mutton been of the class the market needed, much of the trouble which has been experienced would have been averted, for the complaint of buyers has all along been that they could not get enough of the desired quality, and a great deal too much of the undesirable; and it is much to be feared that there is yet a large number of the latter class to be disposed of. However, in districts where forage crops, roots, silage and corn are plentiful it is quite possible that these may come on the markets before the year's end in fair shape, though it will take much feeding skill to put a smooth finish on them, and yet keep them down to reasonable weights. The uncertainty as to the number of these yet to appear, and the great variation in the crops available for sheep-feed in different localities, make prophecies as to market conditions during the balance of the present year very much a matter of conjecture. A lowering of prices from their present point does not seem probable; towards the holiday season they should improve. JOHN P. ROSS, Illinois.

The cow that kicks usually does so because her keeper, through some neglect, has done something that he ought to be kicked for.

## 100 YEARS' WORK And Only One Dollar and Fifteen Cents For Oil and Repairs

A regular Sharples Dairy Tubular Cream Separator recently finished work equal to 100 years' service in a five to eight cow dairy. Here is the record. It proves that

## SHARPLES

### Tubular Cream Separators

are The World's Best.  
Size of machine, No. 4 Tubular  
Capacity per hour, 500 pounds  
Total pounds separated, 2,600,000  
Total turns of crank, 14,352,000  
Total cost of oil, 75 cents  
Total cost of repairs, 40 cents  
Time used in oiling, 15 minutes  
Time repairing and adjusting, 20 minutes

This wonderful record was made by a regular Tubular—just like Tubulars that are rapidly replacing all others. Write for illustrated account telling all about it.

You will finally have a Dairy Tubular because it contains no disks, has twice the skimming force of others, skims faster and twice as clean. Repeatedly pays for itself by saving what others lose. Wears a lifetime. Guaranteed forever by America's oldest and world's biggest separator concern. Write for free trial. Other separators taken in exchange. Ask for catalogue No. 112.



THE SHARPLES SEPARATOR CO.  
WEST CHESTER, PA.

Chicago, Ill., San Francisco, Cal., Portland, Ore.  
Toronto, Can., Winnipeg, Can.



## The PRESIDENT 50¢ AND \$1.00 GUARANTEED WORK SHIRTS

The strongest material is in them—that's why you get the longest wear out of them. Look where you will, you will never find more satisfaction or greater value in Work Shirts than in the 50c Regular and the \$1.00 Special Presidents. Impossible to make them better at the price; impossible to get them better at the price—that's why they're so popular and growing more popular every day. Good looking as well as strong, shapely and well-fitting; made in a variety of attractive fast color patterns.

At your dealers; if not, send us his name, your collar size and price in stamps for sample shirt and book of new patterns.

THE PRESIDENT SHIRT CO.  
10 W. Fayette Street Baltimore, Md.

## DE LAVAL CREAM SEPARATORS

not only save their cost every year but may be bought on such liberal terms as to literally pay for themselves. Why should you delay the purchase of the best separator under such circumstances?

THE DE LAVAL SEPARATOR CO.  
165-167 BROADWAY, NEW YORK. 29 E. MADISON ST. CHICAGO.

## Get Ready for the Fairs Show the Best

There can be but **One Best**

Why lose profits breeding and feeding scrub hogs? Two of our O.I.C. hogs weighed 280 lbs. We are headquarters for breeders. Will send sample pair of our famous

## O.I.C. Hogs

on time, and give agency to first applicant. We are originators, most extensive breeders and shippers of thoroughbred swine in the world and hold the unparalleled record of having been established 47 years without losing a single hog by cholera or any contagious disease.

The L. B. Silver Co.  
1101 Citizens Bldg. Cleveland, Ohio.

We want to mail you our free book, "The Hog From Birth to Sale."

Send us your name

U. S. Gov't inspected herd.

Any owner of live stock, on request, will receive by return mail, charges paid, with no obligations whatever, 8 oz. sample package of the celebrated Silver Live Stock Powder, the well-known disease preventive and conditioner, with directions for its use.

FREE



Digging asphalt from Trinidad Lake

## A roof is only as good as its waterproofing.

Knowing this, will you buy the covering for your roof on its "looks" alone, and not know what it is made of?

# Genasco

the Trinidad-Lake-Asphalt Roofing

is waterproofed entirely with natural asphalt. In Trinidad Lake this asphalt has resisted blazing sun and terrific storms for hundreds of years. It has natural oils that give it lasting life in a roof despite the buffeting of rain, snow, sun, wind, heat, cold, and fire.

Man has tried to make lasting waterproofers—and always failed. Ordinary ready roofings show you what happens. They are made of mysterious "compositions" or coal tar; and they soon crack, break, leak, and go to pieces. Yet as for looks, they are mighty good imitations.

The life and backbone of Genasco is Trinidad Lake Asphalt—the natural everlasting waterproofer—and that makes Genasco last.

Genasco is made with mineral and smooth surfaces. Guaranteed, of course.

The Kant-leak Kleet waterproofs the seams of roofing thoroughly without the use of smeary unsightly cement, avoids nail-leaks, and gives the roof an attractive appearance.

Ask your dealer for Genasco Roofing, with Kant-leak Kleets packed in the roll. Write us for the Good Roof Guide Book and samples.



### The Barber Asphalt Paving Company

Largest producers of asphalt, and largest manufacturers of ready roofing in the world.

Philadelphia

New York San Francisco Chicago

Cross-section Genasco Stone-surface Roofing
Gravel
Trinidad Lake Asphalt
Asphalt-saturated Wool Felt
Trinidad Lake Asphalt
Asphalt-saturated Wool Felt

**FREE** Literature will be sent to anyone interested in the wonderful Sacramento Valley, the richest valley in the world. Unlimited opportunities. Thousands of acres available at right prices. The place for the man wanting a home in the finest climate on earth. No lands for sale: organized to give reliable information. Sacramento Valley Development Ass'n. SACRAMENTO, California

**SAVE MONEY "GET IT"**  
The Common-Sense Conveyor does the work and costs half the money. It's inexpensive, practical, and the easy way to fill silos. **SATISFACTION AND PROMPT SHIPMENT GUARANTEED**. Write now for our "Direct from factory—to you—Special Price."  
Common-Sense Conveyor Co., 305 Factory St., Boonville, Indiana

## Poultry-Raising

### Poultry Profits

Where They Come From

INTEREST in poultry culture is growing in England every year. I have been watching it for some years past, and it is truly remarkable the number of persons who are going into chicken-raising on a more or less extensive scale there," said T. R. Robinson, special lecturer on poultry and live stock at the Agricultural College of Wye, Kent, England, recently.

Professor Robinson is at present on an extensive tour through the Canadian provinces, studying methods of instruction in the branches in which he is particularly interested. Crossing the line into Oregon, he visited a number of American poultry-plants, including that at the state agricultural college, and he expressed the opinion that the Oregon climate is ideal for the poultry-raising industry.

"Possibly the labor conditions in England have something to do with the increased interest in poultry-raising there," Professor Robinson continued. "Naturally, the women feel they would like to help when the family resources are restricted; and thus, doubtless, many of the poultry-farms came into being. And we have there, just as you have here, the movement 'back to the farm.' Since land must ordinarily be rented, and the funds of many people allow them to secure only a small piece of ground, it is natural that they should turn to poultry-keeping, as that industry does not require a very great acreage.

"We have there, as our utility fowls, the Orpingtons and the Sussex. The latter is a white-legged, white-skinned bird, sometimes red-feathered and sometimes speckled. They are a large fowl, and it is not uncommon to find in a flock nine-months-old cockerels weighing nine pounds. Sometimes they are much bigger than that. We use the white and the black Leghorns for layers, and I believe the black is rather the favorite."

Discussing opportunities for poultry culture in this country, as they appear to a visitor, Professor Robinson had several things of interest to say, with considerable advice of a practical nature for the novice.

"The word 'proposition,' especially in British Columbia, appears as often as the word 'potentiality' does in Australia," remarked Mr. Robinson. "Each country, respectively, appears great in both; possibly Oregon combines the two. Although opinions may vary as to the present or prospective value of land, no one, so far as I have been able to discover, doubts that poultry-keeping can be made a paying venture here.

"The land, the climate and the market all appear to be right. But these are only three of the essentials. Two more, equally important, are knowledge and hard work. This, no doubt, is true of any kind of business, but should be strongly urged to the young man or woman starting in poultry. Ample opportunities are at hand for obtaining the necessary knowledge, as, for instance, the agricultural college, an excellent press and numerous private persons already engaged in poultry culture.

"I would suggest the desirability of combining chicken-raising with either mixed farming or fruit-growing, especially the latter. One should begin on a small scale and work the business up. Because a man makes, say, three dollars from one bird, it does not follow that he is going to make three thousand dollars from a thousand

birds. The law of 'diminishing returns' operates very rapidly among fowls. One should not invest too much money. Remember the old adage: 'Don't put all your eggs in one basket.'

"No one should go into the poultry business without some other income to fall back on, for it is only in one case out of a hundred that the plant of the beginner will give him a livelihood. One should begin on a small scale and work up. In British Columbia and elsewhere I have seen numbers of poultry-plants, many of which are fitted with fine housing arrangements, and all are for sale. Why? Because the owners went in too deep in the first place. I have seen many expensive plants in which some one or more of the essentials for successful poultry culture—shade, shelter, grit, green stuff, water and good housing—were lacking.

"Many beginners make the mistake of not specializing in some way—in eggs, for example, or in pure-bred stock. There is no reason why the two should not be combined. Fine laying strains can now be obtained fairly easily; and by straight dealing and judicious advertising good prices should be obtained both for settings, day-old chicks and surplus stock birds during certain times of the year.

"While the favorite egg-producer seems to be the White Leghorn, and there is no need to change perhaps, my personal experience favors the black variety. But whatever the breed, be it Rock, Wyandotte or any other, one should keep the best birds selected from utility stock that has been bred on ability lines."  
ALICE L. WEBB.

### Poultry In New York

WE ARE running one hundred and ten acres of land, and last year raised some chickens with such good results that the story may have some value. We bought two hundred and fifty day-old chicks, May 7, 1909, and raised sixty-five pullets six months old. The cockerels were marketed, bringing enough to pay for all feed up to November 7, 1909. The pullets make us on an average ten cents a month each. They laid 5,160 eggs up to April 30, 1910, which sold for one hundred and twenty-nine dollars. Taking out feed, thirty-nine dollars, left a profit of ninety dollars, all for a few minutes of work each day. We are raising nine hundred chicks this year, and plan to go into poultry-farming in earnest. The chickens are all White Leghorns.  
GEORGE BENSON.

Don't keep the boys out of school to assist in some trivial job. Let them keep up with their classmates.

Once upon a time a dairyman conceived the idea of becoming rich quickly by placing a large potato in each package of butter. Of course, he ceased putting his own print upon each cake that it might not be known who made it.

Have you ever bought merchandise which was unsatisfactory? If so, you will have observed that it is generally made by a manufacturer who has not put his name or trademark on the goods. The maker of good goods is always proud of them. He is willing to make good any defect in material or workmanship.

Therefore, always buy from dealers or concerns who are willing to put their name on the goods and guarantee satisfaction with anything purchased from them.

The Index to Advertisers in this issue of FARM AND FIRESIDE is a pretty good catalogue of concerns with such a reputation.

## Free Roof Insurance Against Lightning

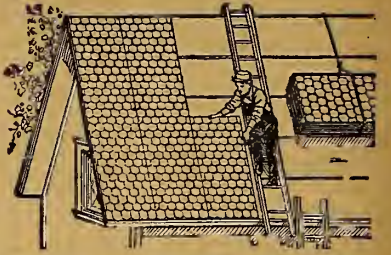

### Edwards Interlocking "Reo" Steel Shingles

Write today for our Big Free Catalog No. 858 which gives full details about Edwards Interlocking "Reo" Steel Shingles and other metal roofing and materials made by us. It tells you all about the Ten Thousand Dollar Guaranty Bond, which insures every Edwards "Reo" Steel Shingle Roof against destruction by lightning for all time.

Edwards "Reo" Steel Shingles are made of high-grade Bessemer Steel in sheets 6 to 12 feet long and 24 inches wide. Either painted or galvanized steel and all ready to put on. You can easily put them on yourself. Only hammer and nails required.

We have a Special Cash Money-Making Proposition for the man who writes for it, in each community. If any of your buildings need roofing, you are the man. Send dimensions of your buildings and we will quote you cost of an Edwards Roof—freight prepaid. Write for offer—NOW.

The Edwards Mfg. Co., 908-958 Lock St., Cincinnati, O. Largest Manufacturers of Steel Roofing Material in the World (50)

## Make Your Loading Easy

Out out the bookshelves, strains and ruptures by using low Empire Steel Wheels for your farm hauling. You can put on a bigger load. Half the cost. Half the time. Save your team. Don't cut up your fields.

### EMPIRE LOW STEEL WHEELS

cost only one-half as much as wooden wheels. They save you tire cutting and repair expense. You can change your wooden wheels for your Empire Steel Wheels any time in 5 minutes. Send for free catalog showing wheels and prices. Write to Empire Steel Wheel Co., Empire Mfg. Co., Box 68-M Quincy, Ill. (10)

## Traveling Salesmen and Saleswomen Wanted

Earn While You Learn. We now have on file letters from thousands of Wholesale and Manufacturing firms who are anxious to employ Salesmen and Saleswomen capable of earning from \$1,000.00 to \$10,000.00 a year and expenses. No former experience needed to get one of these good positions. We will teach you to be a high grade Salesman or Saleswoman in eight weeks by mail and our Free Employment Bureau will assist you to secure a position where you can earn good wages while you are learning Practical Salesmanship. Write today for full particulars, list of good openings and testimonials from over a thousand persons who have recently placed in good positions.  
Address, Nearest Office, Dept. 184

National Salesmen's Training Association  
Chicago New York Kansas City New Orleans Seattle U.S.A.

## Handy Wagons For Farm Work

Low, no high lifting, last a lifetime. Easy for horse and man. Broad tired steel wheels cannot be broken and don't make ruts. No tire setting, nothing to dry apart. All tire work by mail and our Free Book to-day to ELECTRIC WHEEL CO., Box 13, Quincy, Ill.

## ELECTRIC

## \$15 95 and Upward AMERICAN SEPARATOR

FREE TRIAL, FULLY GUARANTEED. Easy to run. Easily cleaned. Whether dairy is large or small, obtain our handsome free catalog. Address BOX 1058 AMERICAN SEPARATOR CO. BAINBRIDGE, N. Y.

## Fastest Hay Press 2 1/2 Tons Per Hour

Greater capacity is guaranteed in all Spencer Presses. The guarantee with our Alligator Press says "22 tons in 10 hours or no pay." Large feed capacity—smooth and compact bales, uniform in size. Load full weight into cars. All Spencer Presses are biggest money makers because they give greatest capacity at smallest operating and repair cost. Write today for Free Illustrated catalog L. L. describing full line.  
Buy Guaranteed Capacity  
J. A. SPENCER  
115 William St., Dwight, Ill.

## 1/2 H.P. Farm Engine \$49.50 2 Kerosene Gasoline \$49.50

Greatest value ever offered in a 1/2 h. p. water-cooled farm engine. Runs any kind of machinery—pumps—saws—separators—feed grinders—water systems—electric light outfits, etc.

### 2 H.P. for \$79.50

Very simple. Uses little fuel. Best material and workmanship. Made to last a lifetime. Shipped complete all ready to run. No extras to buy. Guaranteed by a big responsible concern. Write for catalog TODAY and ask about 30 Day Trial Offer  
Gray Motor Co.  
967 U. S. Motors Building  
Detroit, Mich.

# FARM COMFORT

Sloshing around in wet and mud is no fun, but a pair of good, stout rubber boots, which you can always depend on, makes it a lot easier.

Get the easy, comfortable, long-wearing kind—the

## Woonsocket ELEPHANT HEAD Rubber Boots

We have been making rubber boots for 45 years, often as many as 10,000 pairs a day—in the only exclusive rubber boot mill in the U. S. We make boots for men, women and children; hip boots, knee boots, short boots—all kinds. One man who bought a pair 28 years ago, wrote us that they were still good.

All Dealers.  
WOONSOCKET RUBBER CO.  
Woonsocket, R. I.





# The FARMERS' LOBBY.

WRITING a funeral oration over a patient is never very satisfactory. The patient having passed beyond—having ceased to be a patient and having become simply “the remains”—it is much easier. You can be pretty certain about a man’s virtues after he is dead; he just naturally had ‘em, and it would be a mean person who would raise question about it.

I recollect how Rudyard Kipling had pneumonia a number of years ago, and in the days when we were sure he wasn’t going to survive, we all wrote pieces about him saying that he was the only poet ever—certainly the onliest since Shakespeare. Well, Rudyard got well, and he hasn’t written a respectable piece of poetry since, or a decent bit of economics. He has degenerated into a rank Tory who seems honestly to believe that whatever is wrong is right, and whatever might be made better oughtn’t to be. And it has been rather rough on the people who sprung the premature biographies and eulogies.

## The Free List Bill is Like Kipling

IN THIS matter of the free-list bill, the situation at this moment is very similar. The free-list bill is a patient. It has passed Congress, but it is as good as certain to be vetoed by the President, with small chance of carrying over the veto. So by the time this consideration of its merits and demerits reaches the reader, it will more likely than not be dead. On the other hand, it may be the law of the land.

Some weeks ago, writing for *The Farmers’ Lobby*, I ventured that it would be difficult to discern wherein reciprocity would affect either the cost of living that the consumer pays, or the prices of articles that the farmer raises. Since that time the price of wheat has persistently kept down. That condition has convinced a good many farmers that Canadian reciprocity is bad business.

Take the other side of it. Look up potatoes. The potato crop has not been so bad in many years as right now. Potatoes come in from Canada; quite a lot of them. Statesmen solemnly told us, a few weeks ago, that the pauper potatoes of Canada would ruin the business of the self-respecting American potato-farmer. The potato prophecy was an exact parallel for the wheat forecast: if the Canadian goods ever were let in free, business would be ruined here at home.

Now see what the real result has been:

The other day a man in Colorado walked into a saloon and ordered a glass of beer. He got it, drank it and solemnly took from his pocket a life-sized Irish potato.

The barkeep looked at him, and the bystanders looked at them both. Nobody said a word.

Then the barkeep turned to the cash-drawer, put the potato tenderly inside, took out a nickel for change, and handed it to the customer!

That’s all.

Reciprocity can’t be blamed for the low price of wheat, unless you are willing to give it credit for the outrageous price of potatoes. The fact is that reciprocity has nothing to do with momentary conditions in either line. Potatoes sell by the carat just now, because they’re scarcer than diamonds and much more nourishing. Wheat is down because there has been a good crop all over the world.

## The Farmers’ Business Interests

BUT the free-list bill is to be the burden of this letter; the free-list bill, which is alive to-day and may be dead three days hence. However, you can expect that even if Mr. Taft vetoes it, a similar free list will be enacted into law before two more years. The substance of this measure is going to be made a part of our national policy. Not unlikely when we finally get our tariff policy shaken down to something like a permanency once more, the free list will be a good deal more expansive than the one now under consideration. Therefore, it is worth while to consider what the free-list legislation may be expected to do for us.

They called it the “farmers’ free-list bill,” which was a piece of cheap demagoguery that got on my nerves. The farmers don’t need special attention, any more than other people do; they don’t want to be salved and jollied along. They want a square deal, and are willing that other people should have the same. I have read hundreds of farmers’ letters to congressmen and senators in the last few months, and it is a fact that I never saw so fair-minded a lot of communications from any busi-

## The “Farmers’” Free-List Bill

By Judson C. Welliver

ness interest. The railroad men used to come here with tears in their eyes and assure Congress that it was about to ruin them. The bankers can be counted on for a tale of woe whenever anything is proposed that affects them. The protected manufacturers are always on the point of retirement from circulation if it is suggested to cut their duties one or two per cent. The shipping owners have been for years and years just on the verge of going out of business unless they were given subsidies.

Not so with the farmers. They have been on the whole willing to take their medicine and look pleasant. But, of course, they have a curiosity as to what a particular legislative program is going to do to their interests; and that is why I am writing about the free-list bill in the way that I am.

As it stands to-day, this bill proposes to put on the free list plows, harrows, headers, harvesters, binders, reapers, agricultural drills, planters, mowers, horse-rakes, cultivators, thrashing-machines, cotton-gins, wagons and carts, and all agricultural implements whether in whole or in pieces, and repairs therefor; cotton bagging, gunny cloth, etc., made of jute, flax, hemp, tow, and all the various materials; burlaps and bags or sacks for sacking agricultural products; hoop or band iron for baling cotton, and wire for baling hay, straw, etc.; leather, boots, shoes, harness, saddlery and practically all leathers and leather goods; barbed wire, wire rods, wire strands or ropes, staples, and all wire fencing materials; all sorts of meats, sausages, lard, etc., coming from any country that has a reciprocal trade treaty with us and that admits duty-free cotton, corn, wheat, oats, horses, cattle and hogs; flour of all kinds; biscuits, bread, cakes, etc., coming from any country that admits our cotton, corn, wheat, etc., duty-free; timber, hewn, sided or squared, round timbers, shingles, laths, fence-posts and boards either rough or dressed, except a few kinds of fancy woods, such as mahogany, rosewood and the like, that we don’t much use in building hay-barracks or cattle-stanchions; sewing-machines and all parts thereof; salt; cement, lime and lemons.

There it is. How much is there in it for us?

### How Much Money Does It Save?

How many dollars per annum will you or I save by reason of its passage? How much will it cheapen plows or lemonade or gingham or shoes or ships or sealing-wax, or cabbages, or King drags?

A word about the personal viewpoint, at the beginning. I believe in the free-list bill. It’s a step in the right direction; a proper beginning toward a right policy. I am for it, just as I was for reciprocity; not expecting it to produce any notable effect on the cost of anything in particular; not believing it can either make or break anybody; but just because of a cheerful feeling that the more we liberalize all these tariff matters, the less danger there will be of monopolistic hold-ups entrenching themselves behind exalted schedules and grabbing off all we’ve got.

Take shoes. They pay ten per cent. under the Payne-Aldrich act; harness and saddlery pay twenty per cent. Let me set it down right here that I don’t expect anybody to buy shoes or harness any cheaper if this bill passes.

Why am I for it? Easily enough explained. Last year I spent several weeks in New England shoe-manufacturing centers, studying the conditions of the industry with reference especially to the great monopoly that controls the business of making shoe-manufacturing machines. I found that there is tendency toward consolidation of these interests. The men who control the hundreds of patents and processes for shoe-making machinery are immensely rich and powerful. They are, in many cases, deep in the business of manufacturing shoes, as well as shoe machinery. The result is that the tendency is constantly toward a consolidation of these industries; toward unification of interests. It would not surprise me to see, in fifteen years, a sort of United States Shoe Corporation, with a billion dollars capital, trying to gather in all the shoe-making of the land under one corporate roof, just as the United States Steel Corporation gathered in most of the steel and iron business. That consolidation would be overcapitalized and

unwieldy. It would be an undesirable citizen among us. There is a good deal less danger of such a thing happening, if shoes, boots, leather and leather goods are on the free list. Monopolies don’t grow up so easily when they must compete with the whole world.

Besides the shoe-machinery trust, there is the leather and tanning combination, closely held, and tending to get closer. It is better that they should not be protected behind tariff duties, at a time when they have been notoriously disposed to get together and make their prices just as stiff as conscience and the purchasing power of the community would allow. The tariff as a protection to American labor is one thing; as a shelter to monopoly it is another. And it is my observation that the monopolies are a good deal more active in Washington, looking out for their schedules, than is labor.

Therefore, I anticipate that, though we will describe little evidence of advantage; though prices will not be notably lowered;—yet we will enjoy some real benefits from putting shoes and leather goods on the free list.

### Why the Payne-Aldrich Bill Became Unpopular

THERE is something that is worth while to the farmers; but everybody else will benefit along with the farmer. Now for an item as to which the farmer will be almost the sole beneficiary. Hoop and band iron are put on the free list. The effort has been made for years to do the same thing, in the interest of the cotton-raisers. The people who make cotton-ties have a cinch, and they hold up the cotton industry for every cent the law allows. There is no doubt about this. It has been proved time and again that the prices of these articles are higher than they ought to be. To put them on the free list will make them somewhat cheaper. It is too early even to guess how much effect will be felt; but there will be a better condition.

That will benefit especially the cotton-growers of the South. Putting jute cloth and bagging on the free list will benefit all the farmers in the land. For many years the effort has been made to get these articles free-listed. The years Senators La Follette, Cummins and the rest of the tariff liberals made a big fight to get these things free, and they failed. Not only that. The Payne-Aldrich crowd refused to make the manufactured articles free, and then they gave free admission to the raw material—jute.

The result of that was that the little ring of manufacturers who dominate this industry got their raw materials cheaper than ever, but, behind the tariff wall, were able to hold up the price of their product as high as before! They did it, too; their profits expanded, but the farmer got never a cent’s benefit.

That, by the way, was a fine illustration of the tariff ideals of the Payne-Aldrich people. They handled everything for the interest of the manufacturer; they simply couldn’t see anything, and that was why their tariff, when the country got to understand it, became so unpopular.

### Implement Prices the Same

JUTE, hemp, and like fibers, are the basis also of the linoleum manufacture. The linoleums have a basis of these fibers, with flax, cork, oils, etc. There is the foundation of carpets and oil-cloths, also. Now, the Payne-Aldrich bill provided free raw materials for these groups of industries, but kept up the duty on the manufactured articles. The result has been a huge lift in the profits, and a vast expansion of the industry in the last two years. The free-list bill provides for free baggings, etc., but it does not give free linoleums, carpets, etc. The masses of farmers will get some benefit from the reductions at these points, and the tendency toward combination and artificially increased prices will be stopped, as in the case of shoes and leather goods.

I cannot, after a pretty careful inquiry, hold out much hope to the farmer who expects his agricultural implements to be cheaper as a result of putting them on the free list. The truth is that we have a monopoly, right in this country, of making agricultural implements that we can use here. The Irish, French, Russians and Germans do make some implements; they even sell some in competition with us, in Argentina, Australia, etc. But they couldn’t sell the same ones here because they are not suited to our purposes. They don’t represent as much brains or experience as our implements do, and I doubt if any other country ever will get within hearing of American makers in these lines.



# "The Sunset"

## The Sacrifice of an Old Art-Dealer



By Newton A. Fuessle



FOR twenty years old Grauss had had his gallery on Fifth Avenue, New York. He had lived among paintings all his life, for his father had been a collector and dealer before him. He had come to New York from Berlin with scrip and purse, with argosies of exquisite paintings, with inherent connoisseur instincts, with a burning passion for his profession. These combined to win him quick recognition. Over land and sea came men to look upon his pictures and to buy. To Grauss, at the death of his father, had been transmitted all the wondrous wares that had been his father's.

The building wherein Grauss had housed his cargoes of canvases was a typical one of those earlier days. He converted its interior into a gallery of quaint beauty. Beneath it was a powerful, fire-proof, burglar-proof vault to safeguard the priceless stores he had brought from Germany. The advancing years had wrought many changes in the neighborhood. Modern buildings, taxing the prowess of artisans of construction, had risen grandly along the great thoroughfare, but the humble, old-fashioned building of Grauss' had not been replaced.

"What!" he would exclaim when asked why he did not move or rebuild. "Disturb my pictures! No, it wouldn't be right. This place is good enough for me."

Old Grauss was about sixty, but he looked much older. Rheumatism had assailed the fibers of his body. The blow dealt him by the death of his young wife years ago had projected shadows of moodiness and melancholy through the subsequent years. Intimate friends he had never had. His supreme devotion to his pictures had never brooked the interference of human claim upon his affections.

Day after day, year in year out, old Grauss had lived amid his paintings, save when he boarded an ocean liner for a dash into Europe, to visit renowned painters surrounded by the tools of their work, and to prowl through the galleries of celebrated dealers. Silently, frequently for an hour, he would sit in his den of pictures, peering dreamily at some canvas, fathoming its mysteries and subtle meanings. Often, when addressed by one of his clerks, he did not reply, for he had not heard. Expectant buyers came, only to be ignored by the curious old dealer. And they would depart—not in resentment, but to return another day, for his customers knew they needed to be patient with his moods.

Frequently a motor-car would hum contentedly to the door of the gallery, pause and discharge a distinguished man of great wealth. Grauss would tell one of his clerks to get him "that Corot," perhaps. A little later the visitor would write a check for a good many thousands of dollars and depart with a little oblong canvas.

And so the years passed on. When the weather permitted, old Grauss invariably walked the distance between his apartments on Sixtieth Street and his gallery. Otherwise, he was driven to and from his home in his *coupé*. His steadfast refusal to attend receptions or to dine had at length stemmed the tide of invitations. Old Grauss was a hermit in the midst of the second greatest city in the world.

One perfect June morning, the dealer strode down the fashionable avenue in the direction of his gallery. Spring, mellowing into summer, filled him with vague yearnings for an undefined happiness.

That day something happened destined to play a strange part in the life of old Grauss. Bellamy, his wealthiest patron, visited the gallery with his daughter.

"How now, my friend?" said the jovial millionaire. "The little girl and I thought we would drop in and explore your old den. Let me present my daughter, Mr. Grauss. Elsie, this is Mr. Grauss, the most interesting, although the grumpiest, old fellow on Fifth Avenue."

"I am happy to meet you," said Grauss with his grandest of bows, extending his hand to the young woman. "Ah," he added, for a mood of gallantry was upon him, "I see I have another lovely portrait added to my collection. But, alas, it is only temporarily."

Elsie acknowledged the compliment with a blush. "Grauss," laughed Mr. Bellamy, "the years are leaving you younger, one by one. Upon my word, you are getting to be a regular ladies' man."

"Why not," smiled the collector. "One is as young as one feels."

"With Elsie here, unfortunately," added the father, "it is different. Father Time has to-day clapped another year upon her even score and—"

"You mustn't tell my age, father," objected the girl in quick reproof.

"I'd like to know why not. If I'm going to buy you that Dupré pasture for a birthday, you must allow me at least the satisfaction of announcing your age. I hope you haven't sold that Dupré, Mr. Grauss," he added, turning to the dealer.

When father and daughter were leaving, Grauss said to Miss Bellamy: "Pay me a visit again some time. I will show you some very fine pictures."

"I should love to," she answered.

For many minutes old Grauss stood at the door, gazing at the stream of vehicles into which the wonderful vision of a girl had disappeared. He felt a sort of an unreasoning disappointment that she had gone so soon. There seemed to him to be a something about her that matched perfectly with the exquisiteness of the morning. In the perfection of her beauty he had found nothing to criticize. Her delicately arched eyebrows, her narrow, clearly cut nose, her faintly cleft chin, the witchery of her voice, the charm of her manner, haunted him like the murmured notes of a dear and almost forgotten song of long ago. He wondered if he would ever behold her again.

She did come again, and frequently. Often, on

pleasant days, she might have been seen in old Grauss' gallery. There was a something about the quiet art shop, filled with its painted scenes and moods and fancies, a something about its curious old master, which had quickly laid hold of her interest and her imagination, and had drawn her like a magnet.

Seated together in conversation, or wandering about amid the pictures of the various exhibits, the two made a most interesting picture themselves. It was a picture reinforced and rendered impressive by its contrasts. She, with her dainty, sparkling, electrical beauty, her blue eyes wide with wonder as she listened to the rough low voice of her companion, proclaimed that life for her had but hardly begun. He, on the contrary, shaggy-browed, white-haired, wan, enfeebled, was more like a piece of old parchment, written full of the mysterious characters of a language of a past generation.

With her eyes half closed in reverie, Elsie Bellamy would sit and listen to the enthusiastic collector's words as he related experiences he had had with great painters, or as he invested this picture or that one with new significance, deeper meaning, more potent charm. Thus he unsealed new mental avenues for his young companion, new lanes of understanding, charmed vistas of imagination, unexplored by her before, undreamed of even.

And these were wonderful hours for this inexperienced girl, for this daughter of uncalculated wealth.

And to Grauss, no less, were these hours singularly replete with tremendous satisfaction. The wondrous beauty of his visitor, her genuine interest in that which comprised the sole passion of his life, her ready grasp of his ideas, the warmth and charm of her friendship, the entire freedom and naïveté of her manner, fascinated the old dealer, and he waited impatiently for her coming. In the days between her visits, he would take great satisfaction in planning what rare canvas he would show her next. And, when he conducted her at last to the easel whereon he had placed it, his old eyes would beam with delight at her words of surprise and admiration. Life, in fine, had begun anew for the old dealer. The fair young creature who came to see him was to him a golden thread running through the silvered years of his declining days.

One day, as Grauss and Elsie Bellamy were seated together conversing, Judson French, a young broker, called at the gallery. He was handsome, athletic, tall and magnetic. With strangely aroused interest, Miss Bellamy watched him from the moment he appeared.

"What do you want?" asked Grauss rather abruptly. "I want to buy that autumn landscape in your window, Mr. Grauss. What is the price?"

"It is not for sale," answered Grauss.

"What do you mean? Has it been sold?"

"It is not for sale," repeated the dealer. "I don't understand. A friend of mine told me less than an hour ago that you had asked \$20,000 for it."

"I wouldn't sell it to you at any price, young man. There is nothing here that you can buy," snapped the dealer. "Please go away."

The visitor broke into a peal of good-natured laughter. "You don't seem to realize—" he began with easy assurance.

"Go away!" exclaimed Grauss angrily.

Miss Bellamy had listened with great astonishment. "What made you tell him that?" she inquired when the broker departed.

"I hardly know," said the old man slowly. "There is something about that man I don't like. Occasionally someone affects me that way. The only way I can explain it to you, my child, is to call it a temperamental antagonism. I can't account for it in any other way. All I know is that I felt an unreasoning hatred for him the moment I saw him, and I don't want him to have any of my pictures. I believe it would kill me to know that that man had one of them."

Afterward, when Miss Bellamy was making ready to leave, Grauss said: "Did you see the picture he wanted?"

"Yes. It is a wonderful thing."

"I will give it to you," said Grauss.

Other circumstances, revealing now and again certain odd foibles of the dealer's, served, nevertheless, to make him to Elsie Bellamy all the more of an enigma, incomprehensible and confusing. The strange pattern of his character fascinated her, and drew her with increasing frequency to the studio.

"I am going to show you the most wonderful picture I have, my child," said the old connoisseur one day.

He rose feebly from his leather chair, walked across the room, paused for a moment, then drew a crimson curtain of rich velvet, revealing a landscape which only two or three of his visitors had ever beheld.

"Oh!" exclaimed Elsie. "Oh!"

"*The Sunset*," said Grauss. "It was one of the last things ever painted by Millet."

For a long time neither spoke. As Elsie gazed, the picture seemed to reach out with invisible arms and to envelop her in its mood. The canvas showed a winter evening, bleak and forbidding. Gnarled, gaunt ghosts of trees rose against the stern skies splashed with the blood of the dying sun. In the foreground was a cold pool of water, reflecting the declining sunlight. A bluish sheet of snow lay across the roof of a dreary peasant's hut, from the single window of which straggled yellow rays of candle-light.

"Millet gave it to me," said Grauss, after a while. "I don't let many people see it," he added.

About a week passed.

"May I see *The Sunset* again?" asked the young woman, entering the gallery one day.

"Why not?" said Grauss, crossing the room to the crimson hanging. He revealed the picture, and again the bleak landscape projected its spell upon the girl.

"What is the price of this picture?" she asked suddenly.

"The price!" repeated the dealer, as though in astonishment. "My dear child, it is not for sale. I could not part with it. Can't you see what it means to me? It lives. It talks to me. Compared with this, all the other pictures are as nothing. I could not live without it!"

A tremor ran through the old dealer's body as he stopped talking. He quickly drew the curtain. Slowly he turned to the girl again.

"So you like it?" he muttered.

"More than any picture I have ever seen."

When Elsie had taken her leave, the old dealer drew back the curtain again, and peered long and steadfastly at the painting. Occasionally he murmured to himself: "*She would like to have it—she would like to have it.*" He spoke the words slowly, as though trying to fathom their fuller, deeper meaning. Afternoon sank away into twilight. His clerks went home. The gallery grew dark and no longer showed its pictures clearly. But still the old man sat gazing dreamily at *The Sunset*.

Six months passed. During all this time Elsie, for some reason, did not revisit the gallery. The solitude which descended upon him when Elsie came no more to chat with him became a void which even the wonderful pictures amid which he lived seemed inadequate to fill. The giving, then the taking away, of a friendship more wonderful than anything he had ever known in life went through him like a shock, and left him feebler than he had been in many a day. The weeks dragged dully.

His more important mental processes simmered down at length to two: the yearning to see Elsie Bellamy again and the vague but disturbing fear that Judson French would cross his path again. Ever since the day that Judson French, the broker, had entered the gallery, and had been told to go away, old Grauss had endeavored vainly to erase the memory of the man from his mind. It will be recalled that Grauss ascribed his animosity for Judson French to a certain temperamental antagonism. Had the sensitive-souled connoisseur been able to lift the curtain of the distant past, and to gaze down a certain ancestral trail, he would have seen two bitter enemies in terrific combat in a little clearing of the dark German forests. He would have beheld one of them sink in the end, a quivering wreck, beneath the mighty blows of the other's gnarled club. He would have beheld the victor, himself nearly exhausted, sink upon the dead body of his enemy and chant a weird, triumphant, medieval battle-song. From the loins of the slain warrior had sprung the forefathers of Grauss. The victor was one of the progenitors of Judson French. In incomprehensible, yet imperishable temperamental antagonism had Grauss' hatred of Judson French been handed down to him from the days when men drank from their enemies' skulls in the forests of Germany.

December had come. One afternoon Elsie Bellamy revisited Grauss. The old man looked at her hard, fearful that he was beholding only a vision.

"Well, here I am again," she exclaimed, extending her hand with the cordiality of an old friendship.

"Welcome, my child, welcome," he replied with trembling voice, taking both her hands in his. "You are more beautiful than ever. Come, sit down. Tell me where you have been all this time."

"Oh, I have been everywhere. I left so suddenly for Europe with a party of my friends that I didn't even have time to run in and say good-by to you, Mr. Grauss. Have you been quite well?" she asked, noting for the first time the seams and lines of age in his face.

"I am the same—only older," he said quietly.

For half an hour they chatted.

"May I see *The Sunset*?" she asked eagerly at length.

"That is where you saw it last," he replied, indicating the curtain of crimson. "I am glad that you haven't forgotten."

"I have thought of it often. Do let me see it, Mr. Grauss."

"You told me once you would like to have it," he said.

"Oh, but I couldn't think of letting you part with it," she answered quickly. "It means so much to you."

When she was leaving, she said, somewhat hesitatingly: "I am to be married soon, Mr. Grauss."

"Ah," smiled the old dealer. "I knew that the young men would be wanting you soon," he added with an imperceptible sigh.

"I am to be married—on Christmas," she added.

"Who is the young man?" asked Grauss.

"Judson French," said she.

"Oh!" came from old Grauss' lips as though he had been stabbed.

The young woman hurried away. She knew that her words had stunned the dealer. She had looked forward with dread to the day when she would have to tell him of her engagement. But she had fortified herself against the ordeal with the consciousness that Grauss himself had described his animosity as merely an unreasoning temperamental hatred.

On Christmas Eve old Grauss remained among his pictures long after Fifth Avenue had been transformed into a lane of glittering electric lights. As night fell, he turned on the light above *The Sunset*, leaving the rest of the room in darkness. He sat deep in a leather arm-chair, gazing with absorbed attention at the melancholy landscape.

Presently he rose, went to his desk, picked up a delivery blank, filled in the name "Mrs. Judson French," with her address, and affixed it to *The Sunset*.

Then he sank again into his chair, feebly. His face, haggard in the dimly reflected light, was turned in the direction of the picture.

The day after Christmas, they found old Grauss still seated in the same chair, facing *The Sunset*. His very white face was twisted into a smile. It was the last thing which had been written upon the parchment. He was dead.

# SUNDAY READING

## Good Manners

By Rev. Charles F. Weedon

**I**N THE days of Solomon, two huge brass pillars were built before the porch of the temple. These pillars were probably fifty feet high and eighteen feet in circumference. Hiram of Tyre was a cunning metal-worker, and he ornamented the tall shafts with lily-work. This glyptic skill of the Phœnician workman made the people proud of the beautiful pillars, just as a New Englander is proud of his symmetrical church-steeple, like the one at Park Street, Boston, or a ranchman takes pleasure in his well-built silo, or the Englishman is eager to show you the exquisite carving in the stone of Melrose Abbey.

If the pillars had been plain, not half the notice would have been taken of them. The adornment of lily-work made them attractive. If men see fit to make their buildings beautiful, they ought to strive for personal attractiveness. In other words, there is the

### Duty of Self-Culture

Good manners on the surface appear as "etiquette." This etiquette was at first a ticket or tag tied to a bag to tell its contents. If a bag had this ticket, it was not examined. Then the word came to be cards upon which certain rules were written, to be observed by guests, and finally etiquette came to mean rules by which intelligent people sought to be polite.

It is the duty of a man to make himself agreeable and to appear in personal appearance in a becoming way. An unfinished house is unsightly, and even a fine house unpainted is a rude surprise. We try to surround our homes with graceful vines, velvet cropped lawns, fine gardens and possibly a fountain. So ought we to clothe our bodies, not necessarily in elaborate fashion, but in a comely way. Neatness is not expensive. Fashions may be made distasteful and unnatural—witness the tight-fitting hobble skirt! A dude is a bore because he seems to think only of his dress. A creature of this class once found himself out on the prairies among some cowboys. He timidly asked, "Say, deah fellers, can I wear my silk hat out here?" "Reckon ye can, stranger, if there's somethin' under it!" Mr. Beecher used to say clothing does not make the man, but when he is made, they make him appear better.

### A Recipe for Good Manners

Unselfishness, three drams; tincture of good cheer, one ounce; essence of heart's ease, three drams; extract of the Rose of Sharon, four ounces; oil of charity, three drams and no scruples; infusion of common sense and tact, one ounce; spirit of love, two ounces; mixture to be taken whenever the slightest symptoms of selfishness, exclusiveness, meanness or I-am-better-than-you-ness appear.

Let your speech be with grace seasoned with salt, so as to be palatable and agreeable to people. Much is gained if we can learn to speak quietly. Bluntness is often selfishness or envy. Cultivate a happy way of putting things. A word fitly spoken is like apples of gold in pictures of silver.

It was only a glad good-morning  
As she passed along the way,  
But it spread the morning's glory  
Over the livelong day.

### Politeness Pays

It is a fine trait in a boy to tip his hat, or in a girl to smile pleasantly when friends and elders are met on the street. "Thou shalt be a gentleman" is the first amendment, someone says, to the ten commandments. President Seelye of Amherst College used to say that a gentleman was one who performed acts of "petty self-sacrifice." Politeness goes but little way without sincerity and moral worth. A true gentleman is truthful and a man of democratic spirit.

A lady once entered a drawing-room car and, finding it empty, took her seat. In a few moments a broad-shouldered man entered, smoking, and sat in front of her. The woman looked surprised, and in a moment leaned forward and said, "Perhaps you do not know, sir, that this is a parlor car—the smoker is on the forward part of the train." Without a word the man opened his window and tossed out his cigar. In a moment a porter came through the car and, speaking to the woman, said, "This is General Grant's private car, marm." But the great sol-

dier did not turn his head to witness the woman's confusion as she retired.

This same spirit of deference crops out in athletes. Frequently on the ball-field when a player makes an error you will hear a gentlemanly player call out, "Never mind, old man, play hard." To be sportsmanlike is to play fair. Athletics promote good morals, for it means bodily activity. Laziness makes slovenly manners. Even in commonplace affairs politeness is pleasing.

The English seem to me among the most polite people in the world. Every "cabby" and electric-motor conductor in London will say "Thank you" as he takes your fare. On entering the British Museum I gave my umbrella in charge at the door and the attendant thanked me for the privilege of caring for it! There is, too, a financial profit in politeness. "You are the only young man who takes his hat off when he comes into my office," and the merchant gave the young broker a large share of his business. A western railroad has recently given its two thousand employees a booklet on courtesy. There is money in agreeable manners.

The two pillars in front of the Jerusalem temple were named Jackin and Boaz, or, if we interpret these words, strength and stability. These are at the foundation of true culture, as we have it here in America.

### The Great Triumvirate

of our civilization is the school, the home and the church. School is to develop manly men, not snobs. Education, however, does not run deep enough for the best manners, for polite behavior is in the spirit of a man. Said a college president, "Keep the flame of piety burning upon the altar." Religion is the refining influence of life.

The Christian home tells more than anything else for gentle conduct and true courtesies. It is one of the first duties of the parent to teach good breeding by example and precept. "Eat at your table," says an old philosopher, "as you would eat at the table of the king." If parents were not careless about the manners of their children, they would seldom be shocked at their conduct abroad.

The teaching of the Bible and the church makes for habitual courtesies and kindnesses. Our very presence in the House of God has a refining influence, softening our natures, elevating our thoughts by inspiring music, wise counsel and chaste surroundings. Strength and beauty are in His sanctuary. Architecture, softly tinted windows, the company of respectable, intelligent people, the act of worship, have a molding power over human nature. Underneath all real culture must be unselfishness, good will, altruism, thinking no evil, kindness, sympathy, forbearance, love. Put on these as the crown and adornment of a strong, manly life—the lily-work of the pillar.

God is a lover of dress. He glorifies all his works. Every flower is tinted with richness, every field is covered with a mantle of beauty, every bird is decked with exquisite taste, every star glows with radiant brightness, the ocean reflects marvelous hues of gray and green, and blue and white, and on a moonlit night how entrancing is all creation in the sea, mountain, forest, river, prairie, canyon and glade.

The beautiful effects of a Christian character are manifested in joy, in sorrow, in sympathy and in service. Over all is the halo of a Life and within the purity of a Presence of One who was the first true gentleman and who blended the human and divine in magnetic power and winsome completeness.

\* \* \*

Go, make thy garden fair as thou canst,  
Thou workest never alone;  
Perchance he whose plot is next to thine  
Will see it, and mend his own.  
—Robert Collyer.

Help that other fellow carry his burden for a little way and see how much more satisfaction you will get out of the rest of the day.

Getting mad is sometimes excusable if there is no one around. Even then one usually feels sorry afterward that he was around himself at the time. The memory of it doesn't sit easy on the conscience.

**You Who Get Hungry Between Meals**

Don't deny yourself food till meal time.

When that midmorning hunger approaches, satisfy it with Uneeda Biscuit. These biscuits are little nuggets of nutrition. Each crisp soda cracker contains energy for thirty minutes more work.

Many business men eat them at ten in the morning. So do school children at recess.

They're more nutritive than bread. You can eat them dry — or with milk.

Uneeda Biscuit are always crisp and delightful.

**5c**

In the moisture-proof package

**NATIONAL BISCUIT COMPANY**

Never Sold in Bulk

**HARTSHORN SHADE ROLLERS**

Bear the script name of Stewart Hartshorn on label. Get "Improved," no tacks required.

Wood Rollers Tin Rollers

**We Carpet YOUR Floor \$2.50**

Fashionable, Artistic, Sanitary. Designs from real Turkish Rugs.

**Brusselex Art Rugs**

Fast dyes. Close woven, durable. Can be used both sides. All colors and sizes. 9x 6 ft. — \$2.50; 8x2 ft. — \$2.50; 9x12 ft. — \$4.50. Sent on receipt of price. Freight prepaid. YOUR MONEY BACK IF NOT SATISFIED. Catalog in colors, free. Write today.

KEYSTONE RUG CO., 24 So. 4th St., Philadelphia Pa.

**FARM AND FIRESIDE,**

**Twelve Fortune-Telling Post-Cards**

ALL FOR THE ASKING

A DIFFERENT card for each month in the year, showing the birthstone, the sign of the zodiac and a brief horoscope—witches, owls, crescent moon, black cats and all of the Fortune Teller's paraphernalia. With these cards you can have loads of fun telling the fortunes of your friends. Tell them their lucky and unlucky months and days. You can tell them more about their characteristics than they know themselves. Then, too, we will tell you how to obtain

**50 Elegant Post-Cards Without Cost**

Send us three two-cent stamps right away to pay cost of postage, and in return we will send you, post-paid, a complete set of these new Fortune-Telling Cards. Also a large number of sample Season, Birthday and Good Luck Post-Cards for you to show your friends. Send at once before our supply is exhausted to

**FARM AND FIRESIDE, DEPT. E, SPRINGFIELD, OHIO**

**\$1.50 Switch on Approval**

Send No Money. Just send a sample of your hair. I will match it carefully, and forward you this 22-inch, all human hair switch by return mail on 10 days' trial. If satisfactory send \$1.50 — or earn your own switch by selling 3. Rare shades a little higher. My booklet on hair goods and latest styles in coiffures FREE. Best goods at positively lowest prices. Enclose 5c postage. **VIOLET VALE, Dept. 13, Chicago.**

**1 Trust You Ten Days. Send No Money. \$2 Hair Switch Sent on Approval**

Choice of Natural wavy or straight hair. Send a lock of your hair, and we will mail a 22 inch short stem fine human hair switch to match. If you find it a big bargain remit \$2 in ten days, or sell 3 and EARN YOUR OWN SWITCH. Extra shades a little more. Enclose 5c postage. Free beauty book showing latest style of hair dressing—also high grade switches, pompadours, wigs, pulls, etc. Women wanted to sell our hair goods.

**Anna Ayers, Dept. B15, 22 Quincy St., Chicago**

**NEW HOME**

**THE SEWING MACHINE OF KNOWN VALUE**

**Known the world over for its Serving Qualities.**

The only Sewing Machine which is a life asset at the price you pay. Purchase the NEW HOME and you will not have an endless chain of repairs. It is better made, does nicer sewing, easier to operate, and more silent than any other. Guaranteed for all time. Write THE NEW HOME SEWING MACHINE CO., Orange, Mass. for booklet H

# The Home Interests' Club

By Margaret E. Sangster



## IVERS & POND PIANOS

Embodiment every improvement which half a century's experience can suggest. They are used in nearly 400 leading educational institutions and 50,000 homes.

Where no dealer sells the IVERS & POND we will quote lowest prices and ship "on approval" to your home in the most remote village in the United States. Attractive easy payment plans. Every intending buyer should have our new catalogue. Write for it.

Fill Out and Send this Coupon to

**IVERS & POND PIANO CO.**

125 Boylston Street, Boston, Mass.

Please mail me your new catalogue and valuable information to buyers.

Name.....

Address.....

## SHEET MUSIC 15c EACH

Any 7 for \$1.00 Postpaid

This Music is the same, in every particular, as you purchase in Music Stores.

SONGS—Words and Music for Piano or Organ

- All Alone
- Garden of Roses
- Rad Wing
- Silver Bell
- Sweet Bunch Daisies
- I Love It
- Under Yum Yum Tree
- Kiss Me My Honey
- Star of the East
- My Cavalier
- Stop, Stop, Stop
- Rainbow
- Think It Over Mary
- Daisies Won't Tell
- Steam Boat Bill
- Some of These Days
- Cubanola Glide
- Casey Jones
- Senora
- Honey Man
- Hands Up, "New Hit"

INSTRUMENTAL—Music for Piano or Organ

- Meditation, by Morrison
- Kiss of Spring, Waltz
- Silver Bell, Two-Step
- Rainbow, Two-Step
- Red Wing, Two-Step
- Turkey in the Straw
- Rag-A-Tag-Rag
- Drifting Leaves, Reverie
- Burning of Rome, March
- Southern Dream, Waltz
- Princess Royal, Schott
- Winning Night, March

THE MYREX CO., 248 W. 36th St., New York

Hamilton Draft-Sharing Coupons with all orders.

Send 2c Stamp for "Money-Saving" Catalog

BE AN ILLUSTRATOR—Learn to draw. We will teach you by mail how to draw for magazines and newspapers. School of Illustration, 25 Page Bldg., Chicago, Ill. Send for catalogue.

LEARN TO WRITE ADVERTISEMENTS EARN \$25 to \$100 A WEEK. We can positively show you by mail HOW TO INCREASE YOUR SALARY. Book mailed free. Page-Davis, Dept. 25, Chicago Ill.

**PARKER'S HAIR BALSAM**  
Cleanses and beautifies the hair. Promotes a luxuriant growth. Never Fails to Restore Gray Hair to its Youthful Color. Cures scalp diseases & hair falling. 50c. and \$1.00 at Druggists.

## Income Guaranteed

Liberal commissions; big cash prizes; a guaranteed monthly salary. Such are some of the inducements for you to handle the biggest money-making offer ever made by a farm journal. A fine opportunity for energetic young men and women. Experience not necessary. You must act at once.

Department of Agents  
FARM AND FIRESIDE SPRINGFIELD, OHIO

Direct from Factory, Freight Prepaid and Guaranteed by the Manufacturer  
You can buy a Gold Coin Stove for us \$5 to \$20 less than dealer's prices. We pay freight, safe delivery insured, polished and all ready to set up.  
"Satisfaction or your money back any time within 1 year" is our written guaranty.  
Free Catalog—illustrates all our Stoves, Gives Price List and tells our Plan and Offer. Send for it.  
Gold Coin Stove Co., 8 Oak St., Troy, N. Y.



OR mothers and children the most interesting feature in September is naturally the reopening of the schools. After the summer holiday teachers and pupils resume work with new zest, and in town and country alike, wherever there are happy homes, the little processions of children set out each morning after breakfast intent on the day's tasks. In all the world there is no prettier sight than this of the children on their way to school. Along the country roads, bordered at this season with goldenrod, aster, sumac and many a crimson wreath of briar, they march sturdily forward with books and dinner-pails, and although the schoolhouse may be a mile from home, we may be sure that neither wind, rain nor snow in the later autumn and winter will make them absentees.

The little district school, sometimes half hidden among trees, sometimes at the end of a long, straggling village street and again standing near a church which lifts a white spire heavenward, has been the place in which many a great American has received his earliest training for usefulness. Here one often sees the charming figure of a girl teacher who is patiently and skilfully carrying forward the education of a half-dozen grades at once. She has in front of her the little ones who are learning to read, and back of them a row of older children who are studying geography and history, spelling and arithmetic, while beyond these still there are the advanced pupils who are working hard and preparing to go away another year to an academy or a college preparatory school. All honor to the brave little schoolma'am.

One such I might tell you of who has for ten years left her home in September and gone into a fastness of the mountains in northern New York, hearing from home very seldom during the winter because the nearest post-office is many miles distant and the roads are encumbered by drifts so deep that they are practically impassable. This teacher might find work elsewhere, but she tells her friends that it would not be easy for the people of the little hamlet of the hills to find a substitute for her, and she declares that she does not mind the solitude, and that her work and her books keep her too busy for indulging in the blues or complain of loneliness.

As for the teachers in our public and private schools, wherever we find them and whatever may be their conditions, they are the real builders of our civilization. They are the shapers of destiny and are impressing for good the next generation.

### When Shall They Begin?

The Home Interests' Club was largely attended on the golden afternoon in September when it had been whispered here and there that the topic for discussion would be the children first and foremost, and incidentally the relation of the mother to the school. Every mother and every teacher becomes alert as soon as the phrase "child-culture" vibrates upon the air. The phrase has in it the music of a bugle-note. A club that forgets to have a department for child-culture is certainly out of date, or perhaps it would be more accurate to say that it is not in harmony with present-day conditions and not in touch with things as they are. Our children furnish the incentive for earnest toil on the part of parents.

The speaker who introduced the subject of the day was a woman physician, Dr. Sophie Robarts. She had recently established herself in a conservative section where hitherto the medical fraternity had not been invaded by the medical sisterhood. Already people were familiar with her name on a modest door with her office hours, and her cheerful personality. The latter was winning favor not merely with the doctors of the region, but in families where nervous women needed treatment, or babies required special diet and judicious care. Doctor Robarts began by saying that she was not wholly a believer in the kindergarten. "I approve of it to a certain extent," she said, "but I would far rather have the little children under seven out of doors many hours most days in the year than have them confined in even the pleasantest school-room. While the free kindergarten is a positive boon to the children of the crowded tenements on city streets, children who are ill-housed, ill-fed and scantily clothed, children who need to be sheltered from the elements and taught in tones of kindness, in an atmosphere of love, it is in my opinion not so surely advisable as an educational privilege for the children of comfortable homes, especially in the country. One cannot have much to do with the little children of the very poor without learning that they instinctively dread a blow and are on the watch against it. The small head ducks under the upraised arm to shield itself from injury, and one of the best things done by the teachers in the city primaries is the removal of this cowardice. Children should be fearless and confident, and they cannot be this when they live under a reign of terror. I do not counsel a mother to send her child of five or six to school if she can keep the little one at home under her own eye. It is a mistake to force the childish brain. Health and strength ought to be sought as a basis for symmetrical development in the growing youth."

### A Leaf from Memory

"Well," said an elderly lady who had been listening attentively, "You may be right, and I fancy that the members of your profession, as a rule, endorse your opinions. I look back over the long stretch of years. Probably I am the oldest woman in this company, and I cannot remember the time when I did not know how to read. There were no kindergartens in my childhood, there were good schools in the neighborhood and mothers did not hesitate to send, nor teachers to accept, children of six to sit on the benches and recite from Noah Webster's spelling-book and Swift's Philosophy and Daboll's Arithmetic. These text-books were put in the hands of the smallest children. In the South, the infants would have been compared to the chicks of frying size. I knew my letters before I was three; I read everything in sight by the time I was four, and when I was six, I stood on a platform and recited a long quotation from Peter Parley's History of the Revolutionary War. All this ought, I suppose, to have permanently injured my brain, but it somehow never did. At eleven I studied Abercrombie's Intellectual Philosophy and several other difficult books, including Blair's Rhetoric."

The dear lady paused for breath, not an instant too soon, for one of the youthful mothers was just ready to cry, "I beg pardon, Madam Randolph, but please go no farther until you have told us what you gathered from Swift's Philosophy, at the age of six? As for Abercrombie, I must give that up in despair, although I have a vague notion that I have seen it on the top shelf in my father's bookcase at home."

"Swift's Philosophy," said Madam Randolph, "dealt with things practical and delightful. One was the disintegration of a lump of loaf sugar when dropped into a tumbler of water. None of us were reluctant to try the experiment and we always ate the sugar. Another question throws a light on a custom now obsolete. It was this: 'Why is hot tea poured from a cup into a saucer at the table?' The answer was that the exposure of a larger surface to the air cooled the tea and made it an agreeable drink."

"Great Scott!" exclaimed the son of the house, a lad of fourteen, who had ventured into the room with letters for his mother, was waiting a convenient moment to deliver them, and in the meantime was absorbing ideas from the talk of his mother's friends.

"You need not wait, Hugh," the hostess said, as she laid the letters aside and thanked the boy for bringing them. She ignored his exclamation, and it really voiced the sentiment of a number of club members who seldom themselves used forcible expressions to emphasize their views.

### To Coöperate with the Teacher

"If our meeting is to be of material use at this season, when we are beginning the school work of the year," ventured a dignified and gracious gentlewoman, spoken of in the community as Miss Cornelia, "it may be well to hint that teachers would be greatly aided if they could rely upon the coöperation of parents. I have been at the head of a large school in this country for twelve years. I may modestly claim to have spent more daylight hours with the girls and boys under my charge than their mothers have, during the years between eight and fifteen. The only formidable obstacle to success has, in my case, been the injustice of parents to children, manifestly in weakness and over-indulgence. Few teachers would dissent from my conviction that pupils once entered in school should not be permitted to drop out for days or half-days or parts of a week, unless illness were the occasion. By illness I do not mean a slight indisposition or a convenient headache. I mean a real attack of a malady which Doctor Roberts or any other doctor would diagnose as a sufficient cause to interfere with school attendance. The pupil who is in the school promptly every day during the school year, who stays all day, attends recitations and works in study periods will advance steadily and receive benefit from the training and discipline of the school. Mothers are much too ready to permit indolence and inertia to interfere with regular school attendance. I wish it were not so. I wish the Home Interests' Club would for a while be a School Interests' Club, too."

### One Mother's Remedy

"I have insisted," said the mistress of a farm a mile and a half from the nearest school, "that my children shall never miss a day out of the school year unless prevented by what Miss Cornelia would consider the excuse of actual illness, or else by the conditions of a wintry blizzard. We have had storms through which the stoutest men could not venture far, and then the children have had the unwonted luxury of a day or two at home. If Thomas or Matilda, Helen or Theodore announces to me in the morning that he or she does not feel well and is not able to go to school, I invariably give the child the benefit of the doubt. I say, 'Very well, dear, you need not go, but you must stay in bed, and as you are not well you must have a simple diet.' The plan has worked admirably. If there is real illness, staying in bed is the best possible prescription and a light repast is perfectly safe. If the illness is merely of the imagination, staying in bed is so tedious that school would be preferable, and the request to be absent is not repeated."

### The School Luncheon

"One of my chief solicitudes," said Mrs. Elmore, whose home was nearly two miles from the school, "concerns the dinner-basket. What to give the children for luncheon seems to me important, especially as I believe in a sound body as well as a sound mind. My little Amy has a variable appetite, and unless food is daintily prepared, she cannot eat it. Her brother, Ruius, is at the age when a boy is always hungry and is ready to eat not only at the table, but between meals, and I grieve to say, seems never quite filled up. The school luncheon perhaps appeals to me more than to others, for I have been putting up repasts to be taken to school by six children for the last three or four years."

"I am glad you touched upon that," said Doctor Robarts. And with equal heartiness Miss Cornelia added, "You mothers could do nothing better for the welfare of your children and the good of the school to which you send them than to see that they are well nourished, that they have good food and plenty of it, that they are not overfed with rich pastry and, in short, that their digestion is not ruined before they reach their teens."

"Sister," explained the doctor, "you are a woman after my own heart. Now let us ask Mrs. Elmore what she gives her children as an ideal school luncheon. How does she reconcile the birdlike appetite of Amy with the starved-wolf capacity of Rufus?"

### Sandwiches the Foundation

"The basis of the right kind of school luncheon," said Mrs. Elmore, "is the sandwich. Fortunately it admits of many combinations and a great deal of variety. I think a slice of bread carelessly buttered with a badly cut slice of cold beef or ham laid on it and this surmounted by another slice of bread may indeed be offered the gaunt and famished tramp who knocks at the door, and if he is really in need of food, as he usually is, he will manage to eat it and will perhaps be thankful."

"For the school dinner pail, basket or box, bread should be cut into thin slices, for which purpose a sharp knife should be used. The crusts may be removed and saved for bread pudding. The filling of a sandwich should be of ham or chicken finely minced, of creamed cheese, jam, peanut butter, apple or pear butter, or anything else which the pantry can supply. If the school day is long and breakfast has been early, the sandwiches should be abundant. Biscuits or rolls cut in half and buttered and then spread with sifted sugar, either white or maple, are enjoyed by most children. Fried chicken, hard-boiled eggs, a cup custard, a piece of gingerbread wrapped in paraffin paper, a piece of mince pie similarly wrapped, or whatever is substantial or delicate in the housewife's larder, may properly furnish the dinner-pail. Nice doughnuts and crullers are favorites with children, and so, of course, are cookies. Fruit is always relished and to be recommended. I draw the line at pickles, although in moderation I suppose they may be a safe article of diet."

# The Pickling Season

## Spiced Fruits, Chopped Pickles and Relishes

### And Other Timely Recipes

**Spiced Plums**—Wipe five pounds of plums and prick, each four or five times, with a needle. To one quart of vinegar, add two and one-half pounds of brown sugar, two ounces of whole cloves, one ounce of stick cinnamon (broken in pieces), one ounce of mace and one ounce of whole allspice. Bring to the boiling-point and let boil three minutes. Pour over plums, cover and let stand overnight. Drain, again bring syrup to the boiling-point, pour over plums, cover and again let stand overnight. Repeat the process for two more consecutive days.

**Spiced Pears**—Wash one-half peck of seckel pears, prick with a fork and cook in boiling water, to cover, until soft. Take out carefully, put in a stone jar and pour over the following syrup: Mix one pound of white sugar, one and one-half cupfuls of vinegar and one and one-half tablespoonfuls, each, of whole cloves and stick cinnamon, broken in pieces. Bring to boiling-point and let simmer three minutes. Cover jar and let stand two days. Drain off syrup, bring to the boiling-point, let simmer three minutes and pour over fruit; repeat. In the jar keep a muslin bag, in which is tied two tablespoonfuls, each, of whole cloves and stick cinnamon.

**Grape Marmalade**—Pick over, wash, drain and remove stems from grapes. Separate pulp from skins. Put pulp in a preserving-kettle, heat gradually to the boiling-point and let simmer until seeds separate from pulp; then rub through a hair-sieve. Return to kettle with reserved skins, add an equal measure of sugar, bring to the boiling-point and let simmer thirty minutes, stirring occasionally to prevent burning. Store in a stone jar or jelly-tumblers.

**Spiced Grapes**—Pick over, wash and remove stems from five pounds of grapes. Mix four pounds of brown sugar with one tablespoonful, each, of cinnamon and cloves. Add two cupfuls of vinegar, bring to the boiling-point and add grapes. Let simmer until skins are soft.

**Tomato Catsup**—Wipe tomatoes, cut in pieces, put in a preserving-kettle, bring to the boiling-point and let simmer until soft; then force through a hair-sieve; there should be four quarts of the purée. To the purée add two cupfuls of vinegar, one cupful of sugar, two and one-half tablespoonfuls of salt, one tablespoonful of dry mustard, three-fourths tablespoonful of white pepper, one-half tablespoonful of cayenne and one tablespoonful, each, of whole cloves, allspice, mace and stick cinnamon, tied in a muslin bag. Bring to the boiling-point and simmer until reduced one half. Pour into bottles and seal.

**French Pickles**—A nice, large, white-lined porcelain kettle is the best receptacle in which to boil a quantity of pickles, and they should be canned in stone jars, glass cans or bottles with wide necks. If one is careful to use pure cider vinegar, there will be little or no trouble with the pickles spoiling after they are canned. Chop and mix together one peck of green tomatoes and two quarts of small onions, one head of cauliflower broken in small pieces and one cupful of salt. Let stand overnight. Next day drain thoroughly and boil for fifteen minutes in one quart of vinegar and two of water. Next, take two pounds of brown sugar, one-half pound of white mustard-seed, two tablespoonfuls, each, of ground allspice, cinnamon, cloves, mustard and ginger. Mix together in a little water and add to four quarts of boiling vinegar. In canning the pickles, put in a layer of pickles and then a cupful of the mixture until the jars are full.

**Chow-Chow**—One peck of green tomatoes, four heads of cabbage chopped fine, one peck of small cucumbers, two heads of chopped cauliflower, one pint of radish-pods, one quart of small green bean-pods, one pint of pepper-pods, one-half gallon of small whole onions, or large ones chopped fine. Put each of the ingredients in salt water and let simmer fifteen minutes, but do not allow them to boil. After they are thoroughly drained, put them together in a jar and pour over them one gallon of good vinegar, six tablespoonfuls of ground mustard, one ounce of turmeric and a little salt, if necessary. Put a weight on them and set in a cool place.

**Spanish Pickle**—Wipe one peck of green tomatoes and thinly slice. Peel four onions and thinly slice. Sprinkle alternate layers of tomatoes and onions with salt, using one cupful; cover and let stand overnight. In the morning, drain thoroughly, put in a preserving-kettle and add one half of an ounce, each, of cloves, allspice-berries and peppercorns, one-half cupful of brown mustard-seed, one pound of brown sugar and four green peppers, wiped and finely chopped. Pour over vinegar (enough to cover all), heat gradually to the boiling-point and let simmer one and one-half hours. Store in a stone jar.

**Piccalilli**—One peck of green tomatoes and one-half peck of onions sliced, one cauliflower and one peck of small cucumbers. Let stand in salt and water twenty-four hours, drain and put in a kettle with a cupful of grated horseradish, one ounce of turmeric, one ounce of whole cloves, one-fourth pound

of pepper (whole), one ounce of cinnamon, one pound of white mustard-seed and one pound of English mustard. Cover with cold vinegar, and when the mixture comes to a boil, cook it fifteen minutes and stir constantly. Put in bottles and seal while hot.

**Celery Relish**—Wipe eighteen ripe tomatoes. Remove leaves and root ends from five bunches of celery. Wipe two red peppers. Chop vegetables, mix, put in a preserving-kettle and add two and one-fourth cupfuls of sugar, one and one-half cupfuls of vinegar, two tablespoonfuls of salt and one teaspoonful, each, of cloves, allspice, cinnamon, mustard and celery seed. Bring gradually to the boiling-point and let simmer one and one-half hours, stirring occasionally. Fill bottles and seal while hot.

**Chili Sauce**—Wipe and peel twelve medium-sized ripe tomatoes and cut in slices. Put in a preserving-kettle and add one pepper, wiped and finely chopped, one onion, skinned and finely chopped, two cupfuls of vinegar, three tablespoonfuls of sugar, one tablespoonful of salt, two teaspoonfuls, each, of ground cloves, cinnamon, allspice and grated nutmeg. Mix thoroughly, heat gradually to boiling-point and let simmer two and one-half hours.

**Chopped Cucumber Relish**—Pare and chop fine one-half peck of medium-sized cucumbers and two onions. Salt each separately overnight, drain the next morning and mix. Put in kettle and add a rounding tablespoonful, each, of celery and mustard seed, a level tablespoonful of ground mustard, one-eighth teaspoonful of cayenne pepper, half a cupful of brown sugar and a quart of good vinegar. Boil ten minutes, then bottle and seal.

**Pickled Onions**—Peel small, white onions, cover with brine, allowing one and one-half cupfuls of salt to two quarts of boiling water, cover and let stand two days. Drain and cover with more brine; let stand two days and again drain. Make more brine, heat to boiling-point, add onions, again bring to boiling-point and let boil five minutes. Put in bottles, interspersing with bits of mace, white peppercorns, cloves, bits of bay-leaf and slices of red pepper. Fill bottles to overflowing with vinegar, scalded with sugar, allowing one cupful of sugar to one gallon of vinegar. Cork while still hot.

**Cucumber Pickles**—Wipe and slice twenty-four cucumbers. Remove skins and slice three small onions. Mix vegetables and sprinkle with six tablespoonfuls of salt, cover and let stand four hours; then drain. Mix three-fourths cupful of white mustard-seed, one-half cupful of black mustard-seed, one and one-half teaspoonfuls of celery-seed, two quarts of vinegar and three-fourths cupful of olive-oil. Pour mixture over vegetables and stir with a wooden spoon. Stir thoroughly for three successive mornings.

**Gherkins**—Wipe four quarts of small unripe cucumbers. Put in a stone jar and add one cupful of salt, dissolved in two quarts of boiling water, cover and let stand three days. Drain cucumbers from brine, bring brine to boiling-point, pour over cucumbers and again let stand three days; repeat. Drain, wipe cucumbers and pour over one gallon of boiling water, in which one tablespoonful of alum has been dissolved. Let stand six hours, then drain from alum-water. Cook cucumbers ten minutes, a few at a time, in one fourth of the following mixture, heated to the boiling-point and boiled ten minutes: One gallon of vinegar, four red peppers, two sticks of cinnamon, two tablespoonfuls of allspice-berries and two tablespoonfuls of cloves. Strain remaining boiled liquor over pickles, in a stone jar.

**Spiced Cantaloup**—Ten pounds of very ripe cantaloup cut in one-inch squares, seven and one-half pounds of sugar, one large cupful of vinegar, one-half ounce of whole cloves tied in a thin muslin bag. Put the ingredients on the fire and cook very slowly. If the syrup seems thin, remove the cantaloup and boil the syrup until it thickens. Put the cantaloup in the kettle and cook until done. Can as usual.

**Green Tomato Pickle**—Two gallons of green tomatoes, twelve good-sized onions, two quarts of vinegar, one quart of sugar, one tablespoonful of cloves and allspice, two tablespoonfuls each of salt, brown mustard and black pepper; mix together and cook until tender, stirring often to prevent scorching. Seal in glass jars.

**Sweet Pickles**—Seven pounds of fruit, three pounds of sugar, one pint of vinegar, one ounce of stick cinnamon, one ounce of whole cloves, one ounce of ginger-root. Tie the spices in a thin muslin bag. Put the vinegar, sugar and spices on the fire and when boiling hot, pour over the fruit. Repeat this process three days. The third day, add the fruit to the syrup and bring the whole to a boil. Put in stone or glass jars, cover closely and set in a cool place. Pears, plums, cantaloup, peaches, cherries and watermelon-rind may be pickled the same way.

**Pickled Cabbage**—Chop enough cabbage to make one gallon. Add to it, two green and two red peppers, cut into small strips, and two good-sized onions chopped fine. In a stone jar put a layer of this, sprinkle with

a tablespoonful of salt, add another layer of cabbage, sprinkling it with another spoonful of salt and continue until all the cabbage is used. Cover the jar and let stand overnight; in the morning take it out and press through a colander; put a layer of the cabbage in the jar, sprinkle with a few mustard-seeds and one or two whole cloves; add another layer of cabbage and mustard-seed, and so on until the cabbage is used. Do not pack tightly, cover the cabbage with cider vinegar, and allow it to soak to the bottom of the jar; then cover it again with vinegar and continue until the cabbage is thoroughly moistened with it. It will then be ready for immediate use. Red cabbage may be pickled in the same way, omitting the peppers.

**Tomato Butter**—Ten pounds of skinned tomatoes, four pounds of granulated sugar, three pounds of apples, one quart of vinegar, one-half ounce of stick cinnamon, one-half ounce of race ginger, one-fourth ounce of mace, one-fourth ounce of whole cloves. Tie the spices in a bag; put all the ingredients on together and boil three hours, stirring constantly.

**Cold Catsup**—One-half peck of finely cut ripe tomatoes, one teacupful of onions cut fine, one teacupful of finely cut nasturtium-seeds, one teacupful of grated horseradish, two finely chopped red peppers, three large stalks of celery chopped fine, one teacupful of cold mustard-seed, one-half teacupful of salt, one large tablespoonful each of black pepper, cloves, mace and cinnamon, one-half cupful of sugar, one quart of vinegar. This needs no cooking.

**Pickled Peppers**—Select large green peppers—the sweet peppers are the best to use. Cut a small slit on one side, so as not to cut off any part. Take out all the seeds and soak the peppers for six days in salt water, changing the brine several times. Chop onions, red cabbage, tomatoes, small cucumbers, green grapes, beans, okra, a few slices of carrots, some green corn cut from the cob, some horseradish, whole mustard-seed, celery-seed and a little curry powder. Regulate the quantity of each ingredient according to your own taste. Prepare as much of the stuffing as will fill the natural size of all the peppers you are going to pickle. Before filling the peppers, sprinkle the inside of them with ground cinnamon, cloves and allspice. Then stuff the peppers; neatly sew up the slit, and place in a stone jar; cover with cold spiced vinegar. Put on the lid of the jar and set aside.

**Mustard Pickle**—Equal quantity of small green cucumbers, green tomatoes, button onions or any small kind, green peppers and cauliflower, picked in small pieces. Soak all overnight, drain and put in kettle containing vinegar enough to cover. Make a smooth paste of mustard, sugar and vinegar and add to the mixture. Fill bottles, then cover the corks with paraffin sealing-wax.

**Canned Grapes**—Carefully pick from the stems and wash the grapes; remove the skins, dropping the pulp into one vessel and the skins into another. When all are thus prepared, put the pulps into a preserving-kettle over the fire, and stir constantly until the seeds come out clean; then press the mass through a colander, add the skins to the pulp, weigh them, and to one pound of grapes allow one-half pound of sugar; boil one and one-half hours, and put into glass jars while hot and seal. Thirteen pounds of grapes and six and one-half pounds of sugar will fill six quart cans.

**Grape Jelly**—To every eight pounds of fruit take one coffee-cupful of water; put grapes into a porcelain-lined kettle, and boil until quite soft; strain through a cloth strainer; measure the juice, measure and set aside an equal quantity of granulated sugar; then boil the juice one-half hour, add the sugar and let it boil five or eight minutes longer. All jellies, to be good, should have nearly all of the boiling done before the sugar is added. Fruit that is partially ripe makes the prettiest jellies.

**A Good Picnic Sandwich**—A delicious and substantial picnic sandwich is made with Hamburg steak. Boil round steak in a little slightly-salted water until done, but not long enough to make it stringy, and let it cool. Then mince it fine, and mix it with some chopped pickles, a little lemon-juice, and salt and pepper to taste. Spread it between thin slices of buttered brown bread, press together, and trim neatly. Do not have the sandwiches too small if masculine palates are to be catered to.  
Mrs. M. F. S., Michigan.

**Summer Beverages**—Crush a pound of ripe strawberries and into this slice one lemon; let it stand for several hours after covering with a pint of water. Then strain over a pound of granulated sugar and serve ice cold. Other fruit or fruit-juice may be substituted for the strawberry.

**Date Sweet Sandwiches**—One scant cupful of sugar, one-half cupful of butter, one egg, one cupful of thin sour cream, one teaspoonful of soda, one of vanilla and flour to roll. Roll out very thin in a long sheet, spread one half with stoned and split dates, cover with the other half of pastry, press well together and cut in small squares, rounds or fancy shapes and bake in a hot oven. Ice them if liked.



**THIS**

is the  
**Faultless  
Fruit Jar**

Habit is the only thing that is keeping you to the old-fashioned, ordinary fruit jar. Every year you've put up with the screw top kind that gets stuck three times in five. You had to use that kind, until lately—but not now. That troublesome, narrow-mouthed fruit spoiler is a thing of yesterday, and today it's the all glass convenient

**ATLAS  
E-Z  
SEAL**

Jar for all preserving purposes. See that wide mouth? It takes uncut fruit and vegetables. Gives you all the flavor and all the freshness of summertime foods, right through the winter. Fruit or vegetables can't spoil, can't "work" in E-Z Seal Jars. Top seals air-tight with a finger-push—and opens as easily. It's the jar you ought to have. Sold at all general stores.

Send for our booklet of Famous Preserving Recipes. Tells you better ways of canning and preserving. No charge and glad to mail it to you.

**HAZEL ATLAS GLASS CO.,**  
Wheeling, W. Va.

**1-Qt. E-Z Seal Jar  
FREE for the Coupon**

Please note—In order to secure free jar this coupon must be presented to your dealer before October 1, 1911, with blank spaces properly filled out.  
HAZEL-ATLAS GLASS CO.,  
Wheeling, W. Va.

This is to certify, that I have this day received one "Atlas" E-Z Seal Jar Free of all cost and without any obligation on my part. This is the first coupon presented by any member of my family.

Name.....

Address.....  
To the DEALER—Coupon will be redeemed at the full retail price by your jobber. All coupons must be signed by you and returned before November 1, 1911.

DEALER'S CERTIFICATE. This is to certify, that I gave away one "Atlas" E-Z Seal Jar to the person whose signature appears above.

Dealer's Name.....

Address.....

**DON'T PAY TWO PRICES**  
Save \$18.00 to \$22.00 on  
**HOOSIER  
HEATERS  
& RANGES**

Why not buy the best when you can buy them at such low, unheard-of Factory Prices? THIRTY DAYS FREE TRIAL BEFORE YOU BUY. Our new improvements absolutely surpass anything ever produced. SEND POSTAL TODAY FOR OUR FREE CATALOG AND PRICES

**Hoosier Stove Factory**  
126 State St., Marlon, Ind.



# OUR YOUNG FOLKS' DEPARTMENT

Conducted by Cousin Sally



## Kita and the Three Fire-Sticks

A Two-Part Story—By Ponnie A. Nedwill

PART I.



IN THE days of the great King Jemshid the Magnificent, there lived in the land of Persia a mighty warrior by the name of Mazaran. And in reward for many valiant services, King Jemshid made Mazaran keeper of the eastern boundary of his kingdom and gave him a splendid palace on the edge of the desert. The palace was of stone and of marble, and within it was adorned with gold and silver and precious jewels. And it was built in the form of a square, with a great court inside, and two galleries, one above the other, overlooked the court, and all the sleeping-chambers were above, around the galleries, but below were eight treasure-chambers, two on each side of the court, and the eight doors of the treasure-vaults were made of gold.

Now it came to pass one time that Jemshid the King commanded Mazaran to come to him at Istakhar, his distant capital. So Mazaran made ready for his journey, and before he went he called Kita, his little daughter, to him. Now Kita was ten years old and she had no brothers or sisters and her mother had been dead for eight years. And Risban, her mother's gray-haired nurse, took care of her. Then Mazaran took Kita upon his knee and said, "My little girl, King Jemshid has need of me and I start to-day for Istakhar. Perchance it may be months before I return. You will not grieve for me, Kita?"

At this Kita put her little musk-scented arms around his neck and laid her dark head against his beard and said, "The palace is always lonely when you are away, dear Father, but I shall try to be good and brave until you return."

Then Mazaran kissed her, and rose and put on his gold-colored turban and great robe of brocade, and started off with a hundred of his mighty warriors to the court of King Jemshid. And at his right hand rode Aramin, the fiercest of all his warriors. And Kita and Risban waved farewell to them from the highest turret, and stood watching until the camels looked like little specks in the distance and finally disappeared altogether.

Now one day, five months after Mazaran had gone away, the watchman in the turret called out that a train of camels was approaching. Then was everyone in the palace very glad, for they believed it was their master returning. And little Kita put on her best tunic of striped silk with her girdle of lapis lazuli and went out to the gate to greet her father. But when she was come to where the company was dismounting, she saw that the man on the foremost camel was not her father, but Aramin, the bold, dark warrior that had ridden away at her father's right hand, and with him were a hundred strange men. Then Kita ran back away from the gate, for she did not like Aramin because he was rough and scornful.

But Aramin followed her into the court of the palace and caught her by her girdle of lapis lazuli and laughed harshly.

"Nay, Mistress Kita, do not run away from me! Your father sends greetings and has ordered that I come home before him to prepare the palace for his coming," and he kissed her roughly.

Then little Kita grew very red and she wrenched her girdle free from his hands and asked:

"When is my father coming? And did he send no gift for me?"

"No gift," cried Aramin, laughing very disagreeably, "but a message that in all things you shall obey me, my little mistress. As to when he shall return, who can tell?"

Then he called loudly for food and wine, and set everybody in the palace running hither and thither. And Kita slipped out of the court and went up to tell Risban what had happened.

The next day Aramin gave order that her father's rooms should be prepared for himself, and he gave to his men all the apartments on the second gallery, so that Kita and her attendants were forced to move to the uppermost gallery, and their meat and drink was brought to them as though they had been prisoners. And Kita wondered much that this should be her father's command. Also the men began to drink freely of the wine that was in the cellars and to fill the palace with noise and revelry.

And Aramin removed the gold and jewels out of the eight treasure-chambers around the court and he took down the eight golden doors and set up gates of iron bars in their stead, and in the treasure-chambers he put eight tremendous

lions, one in each of the treasure-chambers, and the lions lay behind the iron bars and glared out into the great court and the whole palace was filled with the noise of their growling and roaring.

Then Kita went to Aramin and said, "Surely it is not my father's will that we should have these fierce lions in the midst of the palace. They frighten me."

But Aramin only laughed loudly at her and made answer, "Trouble not yourself, my young mistress. You will see how glad your father will be when he comes! So Mistress Kita is afraid of the lions, is she?" he cried mockingly.

Then Kita dared say no more, but she was much troubled and longed that her father might return.

Now the very next morning she was awakened by a terrible noise from the court below. The lions were roaring frightfully as if very angry, and moreover she could hear the screaming of a man and the sound of rough laughter. She jumped off her couch and threw on a long white silk robe and ran out on the gallery and looked over the marble railing. Down on the pavement of the court she saw about a dozen of Aramin's men scuffling and struggling, and Kita would have thought they were fighting only for the laughter. Then she perceived that they were tormenting a strange man in a loose blue robe who was in their midst. They would jostle him and trip him up and when he fell to the floor they would seize him and carry him over to the cage

"Stop that, you cruel men! Stop that! Leave that man alone!" But although she stamped her feet and screamed as loudly as she was able, no one heard her because of the roaring of the lions. Then she rang the great alarm bell that hung in the court and straightway the men loosened their hold of the stranger and turned and looked at Kita. "How can you treat that poor man so?" she cried. "What has he done?"

The men looked rather foolish and glanced one at another and said nothing. At last one answered scornfully:

"Call you this a man? Does a man wear his hair hanging down his back in a plait like a woman?"

Now when they had released him the stranger had crouched down on the pavement, but when he heard Kita's voice, he raised his head and looked at her. And he ran forward and knelt beside her and caught her white robe and tried to hide himself behind it. And Kita looked down at him and saw that his hair was coarse and black and was braided in a long queue, that hung down below his waist. His face was flat and his eyes black and slanting upward at the corners and his nose was very short and broad. He wore a strange blue robe and yellow pantaloons and queer shoes without heels and turned up at the toes.

Then Kita spoke to him, and said, "Where do you come from, you poor man?"

The man looked up and answered trembling, "From a country far away, little lady, from behind a great high wall. Men call my country the land of China."

"Why have you come here?" then asked Kita of him.

"Ah," said the man, "I come sell pretty things from my country. The little lady like shawls, silk sash, the perfume of sandalwood?"

"What does he mean?" asked Kita, turning to the men.

"The man has a great pack outside," answered one of them sulkily.

"Ah, I should like to see that," cried Kita. "I will buy myself a new sash and a shawl for Risban. Go bring hither his pack," she begged two of the men.

Then the two men went out and came back with a great bundle wrapped up in a brown cloth and tied around with coarse yellow cord. And they put the pack down in the center of the court at the feet of Kita. And the Chinaman untied the cord and unfolded the brown cloth and brought out beautiful squares of rough silk and wonderful embroideries in gold and gorgeous colors, embroideries of dragons and fishes and strange birds and showed them to Kita. Also he brought out boxes of carved sandalwood and fans with teak and ivory sticks and many splendid perfumes so that the whole court was fragrant with their odor. But the rough soldiers still laughed and mocked the poor man and his wares as they stood round about.

Then the stranger took out a ball of wood, painted blue, as large as the head of a child, and he took it in his hands and twisted it so that it came apart and held a half in either hand. And inside was a red ball a little smaller in size, and after he had taken that apart he showed them a green ball inside of that and inside of the green a yellow one, and so on until he came to the eighteenth ball in the very inside and this was orange and not larger than a pea. And the men ceased laughing as they watched him, for it was marvelous with what skill the ball was made. And when he had fitted all the balls together, he suddenly stood up and cast them from him into the four corners of the court and straightway the men ran and jostled one another to pick up the bright colored toys.

Now as they were busied in this wise the Chinaman took three pointed sticks from his pack and held them out to Kita, crying, "Quick, little lady, hide!" And Kita took the sticks and hid them in her robe. And the sticks were as long as a man's hand and as big around as three of his fingers and they were covered with bright red paper. And the man leaned over and spoke quickly:

"Little lady, great danger! Little lady father, great danger, too—all bad men here! Take stick, put point end in fire—throw at bad man! All fire—big fire!" Then he could say no more, for the rough men gathered around them again with the balls. And Kita was much puzzled and wished she might speak more with the man, for she knew not what to understand by his strange words.

[TO BE CONTINUED]

\*China.



"Then Kita ran back away from the gate, for she did not like Aramin because he was very rough and scornful"

of one of the lions and make as though they would throw him against the bars. And when the lion would shake his mane and crouch and spring against the iron gate and roar with rage, the men would jump back just in time to escape his claws. And all the time the poor man in blue screamed most frightfully and the others shouted with delight over his terror.

Kita stood watching the men in horror until she could bear it no longer. Then she remembered that Aramin had gone forth to hunt the night before and was not in the palace, so she took heart and ran quickly down to the court and ran out into the middle of the pavement and called:

they were covered with bright red paper. And the man leaned over and spoke quickly:

"Little lady, great danger! Little lady father, great danger, too—all bad men here! Take stick, put point end in fire—throw at bad man! All fire—big fire!" Then he could say no more, for the rough men gathered around them again with the balls. And Kita was much puzzled and wished she might speak more with the man, for she knew not what to understand by his strange words.

[TO BE CONTINUED]

\*China.

### Monthly Prize Contest

THIS month our prizes are for the six best verses on one of the following subjects: "Autumn Fairies," or "The Field of Golden-rod," or "My Teacher."

Do not write more than five stanzas. Write in ink, on one side of the paper only, with your name, age and address at the top.

The verses must be endorsed by parent or guardian to show they are original.

The contest is open to all boys and girls who are seventeen years of age and under.

Verses must be in by October 10th. Address Cousin Sally, FARM AND FIRESIDE, 381 Fourth Avenue, New York City.

DEAR COUSIN SALLY—

I thought I would tell you about our school corn-contest that we have every year. There are three counties included, Houghton, Ontonagon and Baraga. We buy the corn from our teacher in the spring.

We plant the corn all by ourselves and take care of it. In the fall we pick six of the best ears and send them to the county fair at Houghton. The biggest and best ear of corn takes the prize. The prizes are five dollars and less, and everyone who buys the corn and plants it receives twenty-five cents for his or her efforts. I am in the contest this year with my brother.

I would like to correspond with some of the cousins.  
LOIS STARBACK,  
Arnheim, Baraga County, Michigan.

### Our Bulletin Board

The names of the lucky boys and girls in our July contest will be announced in our next number.

Alice L. Johnson, of Marysville, Ohio, writes that she has sold all of the onions that she raised in her garden, also a few beets.

From Poplar Grove, Illinois, comes a letter from Harold Harves, saying that he raises rabbits and sells them for fifty cents a pair.

Our girls seem to be just as ambitious as the boys. On my desk is a letter from Evelyn Lyman, of Wakefield, Nebraska, in which she says she has earned her own spending-money by weeding onions. With the \$1.24 that she saved, she is going to buy her school materials.

Marie Strange, of Logoootee, Indiana, is another of our club members who believes in earning her own pin-money. By helping her father count eggs and pick berries, she has managed to save quite a few pennies.

In spite of the fact that most of Gladys Girard's time is taken up studying shorthand and typewriting, she still finds time to keep in touch with our club. She sends her best wishes to the members and says she would like to exchange post-cards with some of them. Her address is 402 South Division Street, Spokane, Washington.

For having the highest general average mark for the term, Annie B. Harvey, of Free-land, Louisiana, was awarded a beautiful book. It pays to do our best—always—doesn't it?

In North Bradley, Massachusetts, there is a branch club of the "C. S. C." It was organized by Alice Scott, one of our active members. With our C. S. C. pin each member wears a pretty bow of blue and white ribbon. Good luck to the club!

Even though our boys and girls have been industrious during vacation, they managed to have good times and fun. Many went swimming or rowing, others went to picnics, some gave parties, some played "house," some played "school," many romped around in the fields and sunshine in their bare feet, or played in the hay-stack, and not a few of the boys went fishing or crabbing with their father. I am glad you had such good fun, because no one likes a good time more than Cousin Sally.

Be sure to read "Kita and the Three Fire-Sticks." It is a fascinating story and you will all love little Kita. The second and last part will be published in our next issue. Look out for it!

Remember that Cousin Sally is always ready to welcome new readers into her large club. You do not have to be a subscriber to join. The club is only five cents.

### Cousins Wishing to Correspond

MARY J. BOWMAN, age 12, R. F. D. 1, Westville, New Jersey.

Alma L. Gould, age 11, Limerick, New York.

Stanton Lawson, age 12, Warwick, North Dakota.

Daisy Gist, age 14, R. F. D. 1, Wolf Creek, Illinois.

Ralph Wolfe, age 10, Van Wert, Ohio.

Bertha H. Case, age 11, Box 324, Cornwall, Orange County, New York.

Charles Miller, age 13, Alexander, North Dakota.

Florence Nelson, age 13, Leasburg, Missouri.

Loela M. Mohrman, age 12, R. F. D. 4, Box 47, Wellington, Ohio.

Ernest W. Parkin, age 14, North Woodbury, Connecticut.

Ruth Rhodes, R. F. D. 77, Cheat Haven, Pennsylvania.

Annabelle Fishback, age 15, Redkey, Indiana.

Ralph A. Enanburgh, age 12, R. R. 4, Box 18, La Porte, Indiana.

Marie Toon, age 13, R. F. D., Wanamaker, Indiana.

Ella Van Doren, age 13, Fairwater, Wisconsin.

Emma Chadbourne, age 11, Alzada, Montana.

Margaret Keough, age 13, R. F. D. 1, Whitney Crossing, New York.

# New Fashions for Early Fall Wear

Practical Clothes for Street, School and Home

Designed by Grace Margaret Gould

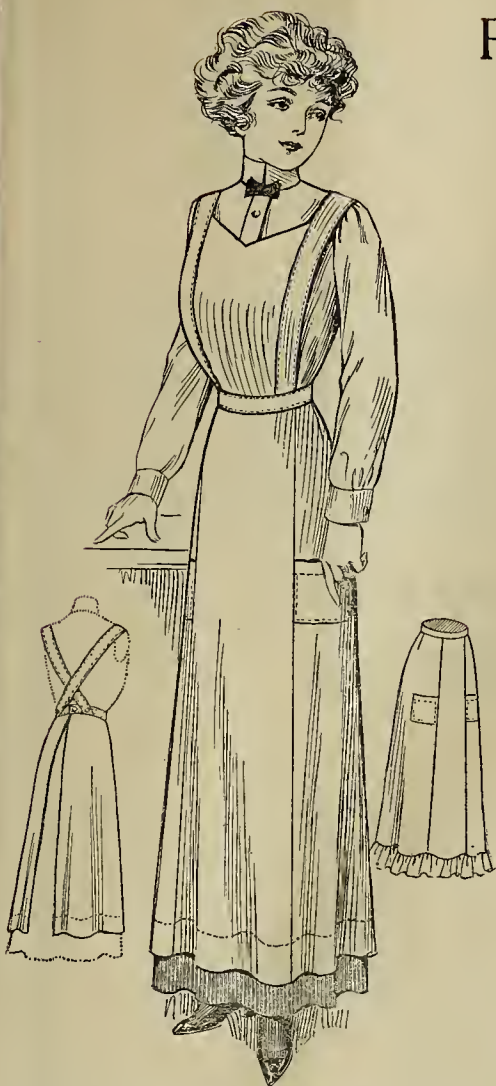

**No. 1823—Housework Apron with Bib**  
 Pattern cut for 22, 26 and 30 inch waist measures—small, medium and large. Material for medium size, or 26 inch waist, four and five-eighths yards of twenty-four-inch material, or four yards of thirty-six-inch material, with an additional three eighths of a yard when ruffle is used. Price of pattern, ten cents



**No. 1824—Princesse Apron with or without Sleeves**  
 Pattern cut for 6, 8, 10 and 12 year sizes. Material for medium size, three and one-half yards of thirty-six-inch material; when sleeves are omitted, seven eighths of a yard less will be required. Price of pattern ten cents

**No. 1838—Russian Suit with Pockets**  
 Pattern cut for 2, 4 and 6 year sizes. Quantity of material required for medium size, four and one-half yards of twenty-four-inch material, or three yards of thirty-six-inch material. Price of this pattern is ten cents

**No. 1825—Girl's Yoke Dress in Two Styles**  
 Pattern cut for 4, 6, 8, 10 and 12 year sizes. Material for medium size, two and three-fourths yards of thirty-six-inch material, with one-fourth yard of embroidery for yoke and armbands. Price of pattern, ten cents

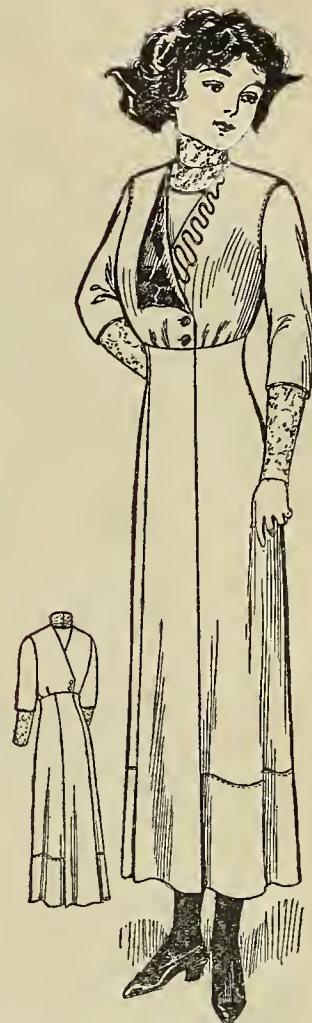

**No. 1828—Buttoned-Over Waist with Revers**  
 Cut for 12, 14, 16 and 18 years. Material required for medium size, one yard of thirty-six-inch material, with seven-eighths yard of contrasting material thirty-six inches wide for the sleeves and trimming and two and one-fourth yards of tucked net twenty-four inches wide for guimpe. Price of this pattern, ten cents



**No. 1851—Four-Gored High-Waisted Skirt**  
 This illustration shows the full view of the skirt to the suit shown on this page. It is an excellent model for a separate skirt as well as for a suit skirt. The price of this pattern is only ten cents

Miss Gould will be glad to help you solve any dress problems that are troubling you. If you want Miss Gould's advice, enclose a stamped and self-addressed envelope in your letter and you will receive a personal letter in reply. Address Miss Gould, care FARM AND FIRESIDE, 381 Fourth Avenue, New York.



**No. 1822—Six-Gored Walking Skirt**  
 Cut for 22, 24, 26, 28, 30, 32 and 34 inch waist measures. Length of skirt all around, 41 inches. Material required for medium size, four yards of thirty-six-inch material. Price of pattern, ten cents



**No. 1845—Panel Waist with Guimpe**  
 Pattern cut for 32, 34, 36, 38 and 40 inch bust measures. Material for medium size, three yards of twenty-four-inch material, or one and seven-eighths yards of thirty-six-inch material, with two and three-fourths yards of all-over lace. Price of pattern, ten cents

**No. 1851—Four-Gored High-Waisted Skirt**  
 Pattern cut for 22, 24, 26, 28 and 30 inch waist measures. Quantity of material required for medium size, four and three-fourths yards of thirty-six-inch material, or four and one-fourth yards of forty-four-inch material. Price of this pattern is only ten cents

**No. 1826—Six-Gored Skirt**  
 Pattern cut for 22, 24, 26, 28 and 30 inch waist measures. Material required for medium size, seven and one-eighth yards of twenty-four-inch material, or four and three-eighths yards of thirty-six-inch material. The price of this pattern is only ten cents

**No. 1852—Coat with Broad Revers**  
 Pattern cut for 32, 34, 36, 38 and 40 inch bust measures. Material for medium size, three and three-fourths yards of thirty-six-inch material, or two and five-eighths yards of forty-four-inch material, and one fourth of a yard of silk. Price of pattern, ten cents

**How To Order Patterns**

The patterns illustrated on this page are just the patterns for every home woman.

They are well graded, clearly lettered and notched patterns.

They are easy to use, directions for using being clearly written on every pattern envelope.

They are inexpensive patterns, too, costing but ten cents apiece.

They may be ordered from FARM AND FIRESIDE, 381 Fourth Avenue, New York; FARM AND FIRESIDE, Springfield, Ohio, or FARM AND FIRESIDE, 1538 California Street, Denver, Colorado.

**A Premium Offer**

To any FARM AND FIRESIDE reader who sends us one new subscription to FARM AND FIRESIDE with fifty cents for the same, we will give as a premium for the subscription one WOMAN'S HOME COMPANION pattern. To obtain a pattern without cost, send the subscription to FARM AND FIRESIDE, Springfield, Ohio.

**Our New Fall Catalogue**

Have you begun to think about your fall clothes yet, and have you remembered that it is nearly time for the fall catalogue of WOMAN'S HOME COMPANION patterns to be out?

It is unwise to decide on your fall and winter wardrobe before you have seen and consulted this splendid guide to correct dressing.

It is full of helpful clothes suggestions.

It is full of designs for mother, big and little sister and even the small boy of the family.

They are practical, sensible designs, and for every design illustrated we sell a practical, sensible pattern.

These patterns cost but ten cents each.

The catalogue costs but four cents. It will be ready for distribution September 20th.

In order to receive your catalogue without any delay, send an early order for it to any of our three pattern-depots.

# Overland

## A Big Fine 30 Horsepower Five Passenger Touring Car—\$900

**T**HERE has never been an automobile made that could approach this value. The farmers of America have never been offered such a thoroughly high grade staunch machine at such a remarkably low price. No other manufacturer in the world can produce this car to sell at this price without losing money. This is a fact that we can prove.

Last year our 30 horsepower car sold for \$1250 and we could not make enough of them. For weeks after this model was entirely sold out the orders kept pouring in. This year our 30 horsepower car sells for \$900. The specifications below tell the story. Compare them with the specifications of any other standard make on the market and see if you can duplicate this car for less than \$1250.

This car is now ready for demonstration. If the *Overland* dealer in your town hasn't received one he will in a few days. Wait and see it. To fully understand the exceptional value of this car you have but to compare it with what the entire market has to offer for 1912. Study the specifications below carefully. In what other car will you find such value at such a price? What machine under \$1250 can you line up against this and item for item see so much for so little money? When you stop to consider the fine, thorough construction—the heavy drop forgings—the pressed steel frame—the selective transmission fitted with F. & S annular bearings (which the most expensive cars in the world use)—the 30 horsepower motor, the big wheel base, the fore-door body with door handles and all shifting levers inside the car, you can better realize what an actual advanced manufacturing step this new car is. It is doubtful if any one ever expected so much in an automobile for such a small price.

We urge upon anyone who feels at all doubtful about this statement to take the 1912 announcement of any other standard maker and see what he has to offer. Just make a few straight comparisons. Take any other similar car—compare the wheel base—the size of the motor—the body—the design—the finish—the seating capacity. See if you can purchase this car below \$1250. And go further than that—find out how the other cars are made and what they are made of. This will reveal some interesting facts about the economical manufacturing strength of the *Overland* organization.

Our 1912 catalogue is now off the press. It explains exactly why no other maker in the business can produce this car to sell at this price without losing money. Write for a copy today.

### SPECIFICATIONS OF MODEL 59-T

Wheel base, 106 inches; body, five-passenger fore-door touring; motor, 4x4½; horsepower, 30; transmission, selective, three speeds and reverse, F & S ball bearings; ignition Dual, Splitdorf magneto and batteries; front axle, drop forged 1-section; rear axle, semi-floating;

wheels, artillery wood, 12-1 ½ inch spokes, 12 bolts each wheel; tires, 32x3½ inches Q. D.; frame, pressed steel; finish, Overland blue; equipment, three oil lamps, two gas lamps and generator; tools, complete set; price \$900.

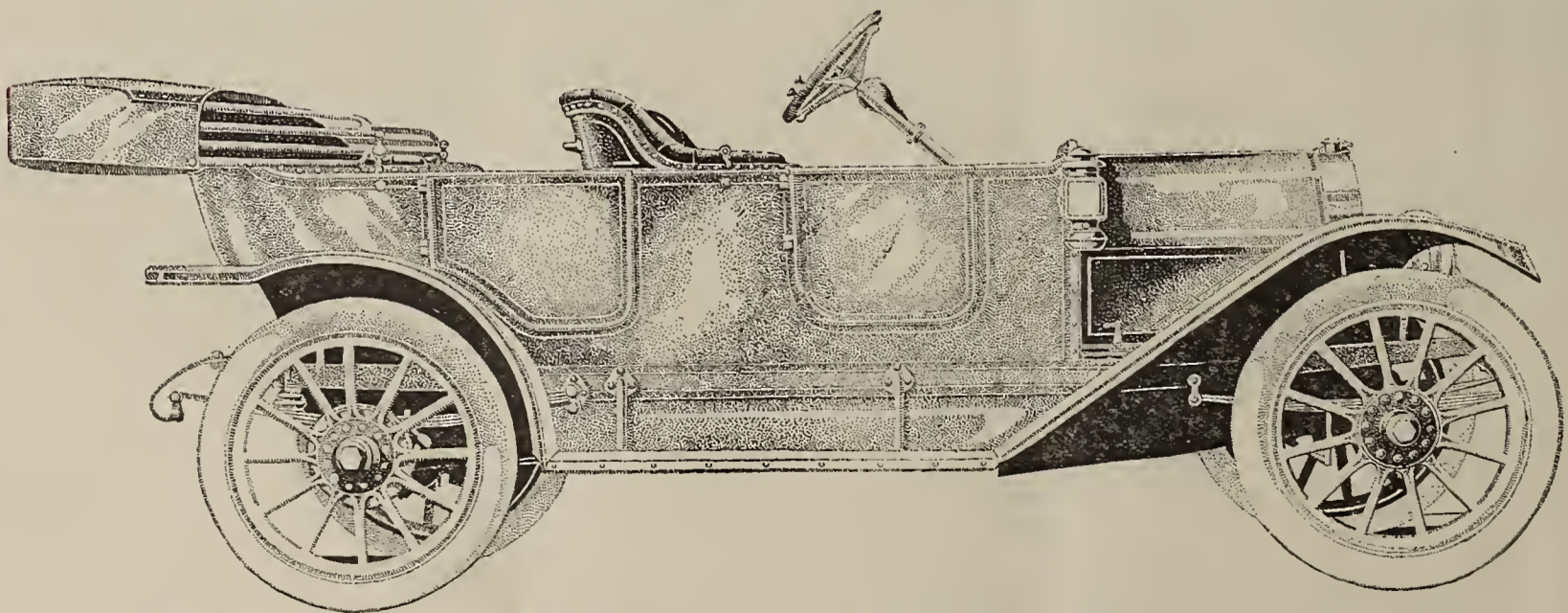

THE WILLYS-OVERLAND COMPANY, TOLEDO, OHIO



34/24

LIBRARY RECEIVED SEP 27 1911 U.S. DEPT. OF AGRICULTURE

# FARM AND FIRESIDE

THE NATIONAL FARM PAPER



ESTABLISHED 1877

SEPTEMBER 25 1911



Live-Stock Returns—A Comparison—Page Five

# With the Editor

**TOWER'S FISH BRAND REFLEX SLICKER**

**WEATHERS THE ROUGHEST WEATHER**

On ordinary slickers, water finds its way in at the front. On the REFLEX Slicker, our REFLEX edge (pat'd) guides every drop of water to the bottom of coat where it drops off

**KEEPS YOU ABSOLUTELY DRY**

**\$3.00 EVERYWHERE**

**SATISFACTION GUARANTEED**

Ask your dealer to show you the REFLEX

**A.J. TOWER CO., BOSTON**  
**TOWER-CANADIAN LTD., TORONTO**

GS11

**PEERLESS**



**SELF RAISING GATE**

is the result of 15 years of successful gate making.

Expert gate builders and high grade materials are combined to make the Peerless gate right.

Big, extra size frames; filled with the famous Peerless all No. 9 wire fencing, cross-bars 6 inches apart. Self-raising, no dragging over snow, ice, rubbish or grass—it lifts itself.

But this is not enough; we are now installing, at enormous expense, equipment to galvanize our gates. Every part will be **HEAVILY GALVANIZED** will be rust proof, will look better and last longer than a painted gate, without raising the cost to the user.

Your dealer can get Peerless Gates. If he will not, write to us.

**PEERLESS WIRE FENCE CO.**  
225 Mich. St. Adrian, Mich.

**P. & B. Fence Anchors**

Keep hogs from going under wire fence. Hold fence down in crossing depressions. Protect stock from lightning by forming ground connection. Hold in any soil. By their use you can set your

**Posts 35-40 Ft. Apart**

Saving half the expense and labor of posts. Simple, cheap, easy to use. No digging. Special driving tool free with orders for 100.

Ask your dealer or write us today for a copy of our illustrated Booklet FREE.

are making \$5.00 a day and up. Good territory open. Send 5c stamps for sample and terms.

**AGENTS**  
J. M. PEEL & BRO., Box 305, Marysville, Ohio

**The "EII" King of Horse and Steam Balers**

A train of followers, but no equals. Proves its superiority wherever it goes. Makes tight shapely bales, not loose bundles, works fast, avoids accidents and endures. Little draft, tremendous power. The machine that makes competitors tremble. EII catalogue free.

**18 Styles**

Collins Plow Co., 1110 Hampshire St., Quincy, Ill.

**FENCE Strongest Made**

Made of High Carbon Double Strength Coiled Wire. Heavily Galvanized to prevent rust. Have no agents. Sell at factory prices on 30 days' free trial. Fully Guaranteed. 37 heights of farm and poultry fence. Catalog Free.

**COILED SPRING FENCE CO.**  
Box 30 Winchester, Indiana.

**ORNAMENTAL FENCE**

25 Designs—All Steel

Handsome, cost less than wood, more durable. Don't buy a fence until you get our Free Catalogue and Special Prices.

We can save you money.

Kokomo Fence Machine Co.  
427 North St., Kokomo, Ind.

**AUTO-FEDAN HAY PRESS**

Only successful self-feed. 2 men can operate it. 20% less expense to operate. Record run 3 tons in 1 hour.

**AUTO-FEDAN HAY PRESS COMPANY**  
1507 W. 12th St., K. C., Mo.

**DON'T PAY TWO PRICES**

Save \$18.00 to \$22.00 on

**HOOSIER RANGES AND HEATERS**

Why not buy the best when you can buy them at such low unheard-of Factory Prices? **THIRTY DAYS FREE TRIAL BEFORE YOU BUY.** Our new improvements absolutely surpass anything ever produced. **SEND NO POSTAL MONEY FOR OUR FREE CATALOG AND PRICES.**

**HOOSIER STEEL**  
**HOOSIER STOVE FACTORY** 126 State St. Marion, Ind.

Ready-Mixed House & Barn

**BROWN'S PAINT**

Highest Quality ever sold direct to the consumer. All middlemen's profits saved.

Write for FREE Color Card, Price List and Booklet which tells the whole story.

**YUMA PAINT CO.**  
820 E. Monument Ave., Dayton, O.

THE county, district, state and interstate fairs are on now, and most of us have seen or will see live stock which will arouse our admiration. But we shall be apt to turn away with the feeling that such stock is not for us.

Farmers know that most of the fat stock shown is of the hothouse sort. A yearling steer (usually twenty-three months old, by the way) weighs fourteen hundred or upward. It will dress out sixty-two per cent. But we think of the wonderful steer, Shamrock, grand champion of last year's International, and if we are well informed, we recall that this steer, from a calf, had two nurse cows all the time, and that these cows were changed until rumor says he had suckled six cows by the time he went to the block.

Every pound of his wonderful carcass had cost the State of Iowa—which fattened him at the college farm at Ames—anywhere from thirty to fifty cents.

Wonderful steer!

But what does it mean to farmers? Merely that the production of such beef would ruin them. It is like the growing of two hundred and thirty bushels of corn in South Carolina by Jerry Moore—interesting and instructive, and worth while as an experiment, but it isn't farming.

But I saw recently sixty-one yearlings in the feed-yards of Capt. W. S. A. Smith, near Sioux City, Iowa, which are worth, as a lesson to farmers, all the regiments of fattened steers in all the shows.

They are only a little less perfect than the Grand Champion, and they have been fed, not for show, but for profit.

They are wonderful steers. Experts are journeying hundreds of miles to see them. The best photographers are making pilgrimages to take their pictures. One load of them when I saw them was scheduled to go to the Interstate Live-Stock Fair at Sioux City, one load to St. Joseph and one to the International.

And they were so uniform that nobody in that region felt competent to say which twenty were the best!

FARM AND FIRESIDE readers know Captain Smith through his all too infrequent articles; but they will know him better now; for his market letter in this issue will be a regular feature from now on. I want you all to know what sort of cattleman it is who will tell you from time to time what he thinks of the cattle outlook.

He is the feeder of this bunch of sixty-one yearlings.

I don't know how they will look among the pampered darlings of All-America's breeders at the International, but good judges say that no man ever had a better bunch of steers of equal numbers.

And they have not been pampered. Captain Smith has not bought for them an ounce of concentrates, oil-meal, cotton-seed meal or anything else not grown on the farm. What these steers have been fed, you can feed yours, if you will grow it.

They have had nothing but corn-and-cob meal, alfalfa-hay and spring-water—absolutely nothing. They have not been stall-fed, curried and blanketed. They have run in and out of an open shed, and eaten from the commonest sort of feed troughs and racks. And they have been fed only once a day!

Their corn-and-cob meal—enough for twenty-four hours—is shoveled into the troughs in the morning, and their hay forked into the racks. They help themselves as they desire. Every ounce of feed is weighed to them, and their owner knows exactly what they have received in all their history, but from eight o'clock in the morning nobody does a thing for them until next morning.

They are Herefords, bought in the sand-hills of Nebraska at four months of age. Of course, they had suckled their dams to the day of purchase. They had some parasites and skin troubles. Captain Smith cleaned them up by dipping. He began with five pounds of alfalfa-hay a day per calf and this ration has never been increased. The increase has been in the corn. Their frames and muscles were built on the alfalfa rich in protein, and gradually the fat-forming corn was increased until every hollow was padded out with it to the butcher's ideal of perfection.

It would make an epicure's mouth water to look at them.

If you go to the International, look for Captain Smith's load of Herefords. They may not take the car-lot prize, but I venture to assert that they would if the prize went to the most perfect cattle most economically fed.

These steers alone are enough to make their feeder famous. And Captain Smith has long been a noted cattleman. His letters to FARM AND FIRESIDE will be backed up by a perfect familiarity with the stock-yards, the commission man's office and the feed-lot. He is on the market every week. But his viewpoint is that of the farmer—for he is a farmer and nothing else.

I am glad to commend his articles to our readers.

**A** MOVEMENT is on somewhere all the time to exempt personal property from taxation in whole or in part, and to concentrate the revenue burden on either real estate or on land values exclusive of improvements. It is at this time in evidence in Illinois and in Oregon. Almost always in these cases the farmers stand out for what we may call the collar-button system of taxation, which seeks to list and tax every blessed atom of property in the community. Just why the farmers should do this is one of the mysteries of human conduct. It would seem that by this time farmers should have learned that they always lose by any law taxing personal property. Money hides. Mortgages and notes disappear across the state lines. Pictures and statuary are beyond the assessor's imagination as to value. Stocks and bonds go to New York for a vacation when the assessor comes around. A fifty-thousand-dollar house doesn't seem much more valuable to the assessor than one of a tenth the cost. But the cattle, hogs, wheat, corn, sheep, hay, barns, fences, silos and everything else that the farmer owns in the way of personal property and improvements are right before the assessor's eyes. Widows and orphans have their personal property listed in court, and can't escape the tax. Hence it becomes true that the only persons who pay personal-property taxes to any considerable extent are widows, orphans and farmers. The farmers of western Canada like the system of placing all the taxes on land. They have discovered that the most valuable land in the world, and that which bears the heaviest tax, is in the cities, and not in the farms. The farmers of Illinois should reflect on the fact that with personal property exempted they would be on a basis of equality with the land-owners of the city.

The farmers own the least valuable land—the thing which cannot be hidden—and most of the personal property which is visible. And yet they go on crying: "Please put the taxes on the things which the other fellow can hide, and which I can't!"

*Robert S. Sikes*

## Index to Advertisements

Agents	PAGE
Collette Manufacturing Company.....	22
<b>Automobiles</b>	
Hudson Motor Car Company.....	11
<b>Carriages and Accessories</b>	
Boob Wheel Company.....	7
Century Manufacturing Company.....	7
Empire Manufacturing Company.....	7
Electric Wheel Company.....	7
<b>Clothing, Boots and Shoes, Etc.</b>	
American Clothing Company.....	11
Glastonbury Knitting Company.....	9
Jensen & Company, Arthur.....	22
Sherman Button Company.....	22
Tower Company, A. J.....	2
Woonsocket Rubber Company.....	16
<b>Correspondence Schools</b>	
International Ry. Correspondence Institute	10
Page Davis Company.....	22
The Engraving School.....	22
<b>Farm Engines</b>	
Gray Motor Company.....	7
Galloway Company, William.....	13
Seais, Roeluck & Company.....	27
United States Engine Works.....	6
<b>Farm Tools and Implements</b>	
Aermotor Company.....	15
Collins Plow Company.....	2
Corn King Harvester Company.....	7
Galloway Company, William.....	8
Hunt, Helm, Ferris & Company.....	7
Mann, F. W.....	10
Standard Oil Company.....	8
<b>Fences and Fencing Materials</b>	
Coiled Spring Fence Company.....	2
Interlocking Fence Company.....	13
Kitselman Brothers.....	12
Kokomo Fence Machine Company.....	2
Peel & Brother, J. M.....	2
Peerless Wire Fence Company.....	2
Up-To-Date Manufacturing Company.....	13
<b>Food-Stuffs</b>	
Baker & Company, Walter.....	23
National Biscuit Company.....	21
<b>General Merchandise</b>	
Montgomery Ward & Company.....	23
National Cloak and Suit Company.....	21
Parcels Post Merchandise Company.....	22
<b>Hair Goods</b>	
Ayers, Anna.....	22
<b>Hay-Presses</b>	
Ann Arbor Machine Company.....	6
Auto-Fedan Hay-Press Company.....	2
Kansas City Hay-Press Company.....	9
Spencer, J. A.....	8
<b>Household Miscellaneous</b>	
Collette Manufacturing Company.....	22
Hoosier Stove Company.....	2
Imperial Steel Range Company.....	23
Kirk & Company, James.....	22
Kalamazoo Stove Company.....	23
Lincoln-Leonard & Company.....	23
<b>Land</b>	
Atlantic Coast Line Railway.....	10
Chicago and Northwestern Ry. Company.....	8
McBurney & Company, F. B.....	13
Northern Pacific Railway.....	10
Pearson Company, William.....	9
Sacramento Valley Development Ass'n.....	7
Southern Railway Company.....	6
<b>Live Stock, Stock Food and Remedies</b>	
Newton Remedy Company.....	6
Silver Company, L. B.....	7
<b>Paints</b>	
Acme White Lead and Color Works.....	12
National Lead Company.....	8
Yuma Paint Company.....	2
<b>Patents</b>	
Evans & Company, Victor J.....	6
Farnham & Sues.....	7
<b>Publications</b>	
American Magazine, The.....	12
Curtis Publishing Company.....	19
Rosier, Will.....	23
Roberts Veterinary Company, Dr. David.....	6
<b>Roofing</b>	
Barber Asphalt Paving Company.....	7
Barratt Manufacturing Company.....	10
Bird & Sons, F. W.....	6
Century Manufacturing Company.....	16
Edwards Manufacturing Company.....	8
<b>Separators</b>	
DeLaval Separator Company.....	6
Galloway Company, William.....	12
Sharples Separator Company.....	7
<b>Sporting Goods</b>	
Aurora Automatic Machinery Company.....	8
Winchester Arms Company.....	13
<b>Telephone Apparatus</b>	
Western Electric Company.....	13
<b>Weil-Drilling Machines</b>	
Austin Manufacturing Company.....	9
William Brothers.....	9

## ABOUT ADVERTISING

FARM AND FIRESIDE does not print advertisements generally known as "readers" in its editorial or news columns.

Mention FARM AND FIRESIDE when you write to our advertisers, and we guarantee you fair and square treatment. Of course we do not undertake to adjust petty differences between subscribers and honest advertisers, but if any advertiser in this paper should defraud a subscriber, we stand ready to make good the loss incurred, provided we are notified within thirty days after the transaction.

FARM AND FIRESIDE is published on the 10th and 25th of each month. Copy for advertisements should be received twenty-five days in advance of publication date. \$2.00 per square line for both editions; \$1.00 per square line for the eastern or western edition singly. Eight words to the line, fourteen lines to the inch. Width of columns 2 1/2 inches, length of columns two hundred lines. 5% discount for cash with order. Three lines is smallest space accepted.

# FARM AND FIRESIDE



PUBLISHED BY  
THE CROWELL PUBLISHING COMPANY  
SPRINGFIELD, OHIO  
Branch Offices: 381 Fourth Avenue, New York City; Tribune Building, Chicago, Illinois  
Copyright, 1911, by The Crowell Publishing Company  
Entered at the Post-Office at Springfield, Ohio, as Second-Class Mail Matter

## A BLUE MARK

In the square below indicates that you are an old subscriber and that your subscription expires this month. Renew by accepting one of our offers before they are withdrawn.



## SUBSCRIPTION PRICE

One Year (24 numbers) 50 cents  
Canadian, 1 Year . . . 75 cents

Subscriptions and all editorial letters should be sent to the offices at Springfield, Ohio, and letters for the Editor should be marked "Editor."

Silver, when sent through the mails, should be carefully wrapped in cloth or strong paper so as not to wear a hole through the envelope.

Vol. XXXIV. No. 24

Springfield, Ohio, September 25, 1911

PUBLISHED  
SEMI-MONTHLY

Ruralize the rural schools.

Good roads lead to prosperity.

Good fences always promote neighborhood amity.

The farmer who never gives his boys a chance to go fishing is helping to populate the cities and the towns.

### Our Love of a Lord

IT IS said that an Englishman dearly loves a lord. In this respect we are all Britons, judging from our tenderness in handling our peculiar sorts of lords. Two brothers named Rosenberg were recently convicted of undervaluing silks at the New York custom-house and fined \$25,000 each. They had made more than ten times the fine in the deal. This fine was just the same thing as letting them off altogether. They cheated the government out of a little less than a million dollars and were made to pay a twentieth of the sum as a penalty for getting caught—and, of course, to return the money they had stolen.

Just before the last rich importer received his fly-bite sentence, a man—called by the district attorney "a poor sick Greek"—was sentenced to three months in jail for undervaluing some figs and cheese imported.

The manner in which rich men are favored in our courts makes of them a net which breaks to let the big fish out. When the parliamentary armies were fighting Charles I., the generals used to avoid taking the king prisoner. They dreaded to lay hands on the "Lord's anointed." The rich are our "Lord's anointed," apparently. Mr. Wickersham let the packers go when they were in the toils for rebating, and is easy in his mind while the statute of limitations runs in favor of Alaska land-grabbers. Are the fish too big for the net to hold?

Said King Lear:

Plate sin with gold  
And the strong lance of Justice hurtless breaks:  
Arm it in rags, a pygmy's straw does pierce it.

Notwithstanding the occasional conviction of a Morse or a Walsh, the strong lance of justice breaks as hurtless now against the golden armor—we almost said Armour—as in Shakespeare's time, or Lear's.

This is no plea for severity. Perhaps our laws are too severe. But we call, and the people of this nation call, for a square deal in the courts, for the same jail, the same electric chair, or the same mercy for the great man as for the small one.

After the armies of the parliament had evaded the capture of the king for a while, there came into power a sturdy man named Oliver Cromwell. Said he, "If I meet the king in battle, I will fire a pistol into him the same as any common man."

We want men on the bench who will fire a jail sentence, or a parole, into our king—money—the same as into Bill Smith who robs the railway company by throwing coal from the cars at the top of the grade.

The Cromwell spirit, which is no respecter of persons, is the spirit which seems likely to rule in this country one of these days. And Rosenberg fines will speed the day.

### The Coming Education

WHEN Blackstone wrote his Commentaries, he did not expect them to become the text-book for lawyers. He prepared them as lectures to young gentlemen who were to be prepared by them for life as gentlemen by a study of the laws of their country. His idea of the matter was that the fashionable education for well-to-do and aristocratic men would be and should be the law. In this he was only partially right, and was right at all for only a short time. The classics, theology and other branches of learning have always been the fashionable

things for rich men's sons to pursue. And then came science with its thousand doors to profit and pleasure.

And now there is good reason to think that the agricultural course will soon become the fashionable one. Already it is one of the most profitable. Jobs as engineers used to await the student when he left college with his diploma; but employment at fair wages is now easier to be got by the "agric" than by the engineer and chemist. There is a great and growing scarcity of skilled scientific farmers. Men with lands are anxious to have them scientifically farmed and are willing to pay good salaries to young graduates who can make good in the bank-book.

And this brings agricultural education within sight of the danger of becoming fashionable. Already rich men are sending their sons to the agricultural colleges with the idea that the course will be useful to them in the management of their estates. If this continues, the time will come when the agricultural graduate will average no better in efficiency than those in medicine, law and theology. Fortunately, though, that day seems far off. For some years to come the best course for the poor boy, measured in culture, in college associations and in business opportunities, will be the agricultural course—if he is the right sort of boy.

Early in the spring a Woodbury County, Iowa, young man sickened and died suddenly before his crop was planted. He left a wife and several small children. Her neighbors came and planted her crops, and agreed to club together to cultivate and harvest them for her. That work was done. Such a consolation counts for something. It is an example well worthy of being passed on to other communities.

Take your choice: pursue a profitable course of furnishing the dairy herd all of the grass that they can eat, or adopt the less profitable plan of crowding enough animals onto the lot to keep the grass gnawed into the ground, which insures you a herd of skin-and-bone stock. What has been your choice this past season?

### Wanted: a Dog-Trap

IN MANY parts of the country farmers are deterred from sheep-raising by fear of the ravages of dogs. We trap rats, poison gophers, shoot hawks and spray insects and fungi—why can't we do something with the sheep-killing dog? Poison? It makes trouble in the neighborhood. How about trapping them? We have seen a plan for a trapping scheme which doesn't look very convincing to us. Have any of our readers anything to say on the subject of trapping the sheep-killer? Any good scheme will do, but the one which will secure Ponto with the wool in his teeth will be preferred.

### Poor Clover, Poor Farm

ISN'T the above true? But if you have a farm which is poor because it is poor for clover, the disease may be cured, perhaps. Maybe the soil is sour. Test it, next summer, and see. Put a square rod in good tilth, manure it lightly and plant it to table beets. Do the same with another square rod—just the same, except that on the second patch apply twenty pounds of lime, well worked down into the soil. If the beets grow a good deal better on the limed patch than on the other, the land needs lime in order to be fitted for clover. If you don't know how to lime it, look it up in the back numbers of FARM AND FIRESIDE, or ask advice.

Clover is the basis of good agriculture—or if not clover, some leguminous crop or crops. Don't manure for clover, ordinarily. The manure should go on the field as the clover goes off—spread it on the clover-sod just before plowing it up.

If you haven't a good clover farm, the responsibility already rests with you to know the reason why.

If you love your enemies, they are not.

Few things are as bad as the pessimist, or so good as the optimist thinks.

The fertility of the soil can be, and must be, maintained. Intensive farming, fewer acres and more neighbors will make living in the country more desirable and make coöperative production and marketing and purchasing more practicable.

### As of Yore

AN ESTEEMED exchange is worried because, since the reciprocity bill has passed, American farmers are in danger—if the treaty is ratified by Canada—of being forced to "buy on a protected market and sell on an open one." That's always been the case. We have always had to sell ninety-nine dollars' worth of produce in an open market to one dollar's worth on which we had "protection." And we have always had to buy on a protected market. The only difference is that we can all see it now. We are stung, perhaps, but, if so, it is in the old, old spot.

All seed-corn should be selected from the stalk in the field, so that one can study not only the grain in the ear, but the health and vigor of the stalk.

### Hogging Off Corn

MEN who let the hogs husk some of the corn are as a rule satisfied with the results. The hogs eat up the crop as closely there as in the pen. They make better gains than if fed the same amount of ear-corn. It costs less to fence off the corn in lots as needed than to husk it. And it is easier work. The droppings are in the fields where they should be. The hogs have a chance at the weeds which are edible, and get plenty of exercise. If rape is sown in the corn for an addition to the ration, the animals will do much better than if fed on corn alone. This does not mean that all the corn should be hogged off, nor that all hogs should be finished in that way. It means that on almost every corn-belt farm some money can be made and some work saved by the practice.

In most sanatoriums there is a rule that the patients shall not tell each other about their ailments. Pretty good rule to follow anywhere, isn't it?

### The Rural Parcels-Post Delusion

FROM present indications it looks as if Postmaster-General Hitchcock and President Taft will go on with their delusive scheme for instituting what they call "a rural parcels post." That is, a parcels-post system confined to the rural route on which the parcel is mailed, the town or village to which the route runs and the other rural lines radiating from the same office. In other words, the scheme will not give service from one post-office to another. In our opinion such a weak, limited and feeble attempt will fail in almost every respect. It will fail to give farmers access to the towns where they want to do business, for the rural routes mostly avoid the large towns and start from the villages. It will fail to help the department to work out the problems of real parcels post, for it will be nothing more than an errand-boy service to town and to neighboring farms.

We think that all true advocates of parcels post will fight the measure and kill it, unless it is so extended as to take in a zone at least fifty miles in radius from the mailing-point. We have asked for bread, and are offered a stone. Let's go hungry with dignity if hungry we must go. It is a positive fact, however, we cannot accept this thing with any sort of self-respect.

# Pure Water for the Country

By Dr. F. M. Bogan

**T**HE centers of population—the cities and towns—possess benevolent governments which provide us with a never-failing supply of pure water. It may be that some time in the future this benevolence will extend to the country districts, to such an extent that the various springs, wells and streams may be labeled good, or bad, as the quality of the water proves them to be. But, as yet, it has not been done and so we find many people drinking water that is only fit for irrigation purposes.

Water comes from the condensation of vapors present in the atmosphere, and is deposited in the form of dew, fog, rain or snow. Most of this water remains on the surface in the form of brooks, rivers, ponds, lakes and the ocean, while the remainder works through the soil until it reaches an impervious layer, such as clay or slate. In its passage through the soil it dissolves and carries with it a certain amount of organic and mineral matter. This layer of water upon an impervious layer of soil or rock forms the water stratum, and it is the source of all the wells and springs. When a well is dug, we simply penetrate the porous soil, until the layer of clay or rock is reached below which the water cannot penetrate.

Rain-water is the purest of natural waters, but it contains some impurities, such as dust, salt, ammonia and organic matter. These atmospheric impurities can be disregarded, for little evil results from their presence.

## Where to Look for Good Water

Owing to the absence of magnesium and calcium salts, rain-water is often called "soft." When the supply of other water is not sufficient, or is impure, rain-water, stored in tanks or cisterns, should be used. If cisterns are constructed, the ordinary mortar should not be used, as the lime is dissolved in the water and the latter becomes hard. Brick or stone with cement should be used. If tanks are used, galvanized iron is admirable; it is well to cement the interior. Cisterns and tanks should always be covered and the light excluded, for light encourages the growth of vegetation. The disadvantages of such a supply are the difficulties of determining the amount of rainfall and the uncertainty as to the amount of water required.

Spring-water is usually clear and cold because of the depth from which it comes, and the degree of filtration that it receives in passing through the layers of the earth. If the surrounding country be hilly, springs at the foot of hills will probably be permanent. In limestone and granite formations the springs are usually permanent, while the porosity of chalk formations allows the water to percolate through the denser strata below. A well-wooded watershed also tends to permanency.

Wells may be deep or shallow. Artesian wells are very deep and the water is under high pressure. It is as a rule of excellent quality, but more or less flat and not so pleasant to the taste as spring-water. In shallow wells the water frequently contains organic matter. As a rule shallow wells are dangerous and the water should not be used. Wells and springs should be enclosed with sides of brick or stone; the ground around them sloping away to drain off the surface water. Wells should have vaulted tops with a manhole in the center and the pump placed at the side. Inhabited buildings, especially outhouses, barns, stables and pig-pens should be placed as far as possible from the water-supply. The radius of the surface area drained

by a well is considered to be equal to an area four times the depth of the well. That estimate is pretty accurate.

The water of small lakes is, as a rule, loaded with animal and vegetable matter and is unfit for use. The water of large lakes is pure, except where the sewage of towns and cities is emptied into it along the shore, but even in such a case we find the water about half a mile from the shore pure.

River-water varies greatly as to composition; rivers may be practically open sewers and the use of such water would be fraught with great danger. Running water does undergo a self-purification, but it would not be safe to consider this process complete under twenty to forty miles of the sources of pollution. In such a water the solids soon drop to the river-bed, the smaller particles being purified by the oxygen present. The disease organisms present in the surface water are quickly killed by exposure to the sunlight, while the others settle to the bottom. There is also the biological action of certain small forms of life that play a most important part in this purification. It is due to the processes just mentioned that a river may receive all the sewage of a large city and fifty or a

hundred miles below may be used as the water-supply of another city, the water, in its passage, having become practically free from impurities.

From what has been said it is evident that a spring, a well, or a stream of rapidly running water is the most desirable supply. But how can we tell that the water is fit to drink? A pure water should be clear and sparkling, of a pleasant taste and no odor. But water may be all this and still contain a large amount of vegetable and animal matter with disease bacteria. In cases of doubt, it is necessary to have both a chemical and a bacteriological examination made. By chemical examination we can determine its mineral and organic content, and as a rule this is sufficient to show whether or not the water is fit for use. The two valuable points in the chemical examination are the determination of the amount of the organic matter and the chlorides present. Let it be understood that the organic matters and the chlorides usually present in water are not themselves injurious, but being formed from the excreta they indicate a contamination of the water by sewage and the possible presence of disease germs. Organic matter may be animal or vegetable. An amount of vegetable (organic) matter sufficient to cause discoloration and unpleasant odor may be present without rendering the water unfit for use. An increase of the organic products (ammonia, nitrite, nitrate) with chlorides indicates an animal pollution; without chlorides, a vegetable pollution. The chlorides are derived directly from the animal excreta, and a large amount of these salts present should excite the suspicion of sewage.

## Why Not Secure an Analysis of the Water?

In every case where it is possible to secure analysis of the pure waters of the neighborhood, such analysis should be compared with the sample. The value of the chlorine content in showing the presence of animal pollution is so well recognized that the state boards of health have already completed a set of standards for New England. These standards show the amount of chlorine which may be permitted in pure water in the

various localities. A bacteriological examination is made to estimate the number of colon bacilli present. This bacillus is normally present in the human intestine and is excreted with the feces. If it is found to be present in the water examined, it shows that there has been a direct leakage of sewage into the water. If this bacillus is present, it indicates that other bacilli, such as the typhoid, may also be present.

Let it be emphasized that all water as it falls from the clouds is practically pure, and it would remain so if the excreta could be kept from contaminating it. As a rule, in the country this contamination comes from the unsanitary disposal of sewage.

## Abandoned Farms

**M**R. CLIFFORD E. DAVIS, of Maryland, is always interesting and very frequently right. Concerning the abandoned farms, and the abandoned farmer who causes it, he writes as follows:

Some time ago a widely known real-estate man sent me a list of abandoned farms for sale all over the whole country. Some had "good water, buildings in good repair, stock and tools thrown in." Every week in my own county there are farms for sale; and on every farm that I know of there is a field or two, often several, thrown out for pasture, or lying idle, barren and neglected. The farmers are not farming to their full capacity, and in the face of unheard-of prices of all grains and produce we wonder why it is so. It will be this way as long as there are renters, who get off all the crops the land will bear, or who take a farm on mortgage, and then skin it of telegraph-poles, lumber and posts, and then let it go to mortgage sale, or sell it and take another.

Hardly one tenth of them are teaching their sons the way to farm as well as they do themselves, or better.

James J. Hill has said that in ten years America will cease to export grain, and will have difficulty in feeding itself, with unprecedented hard times as a result. With the high prices of bread and wheat in the past few years, and "the bread line" in New York every winter, this can easily come to pass. The remedy is for every farmer with a son to make that son an expert farmer, not a land butcher.



The water layer (A) is polluted by sewage coming through the porous soil (B) represents the impervious clay layer. The spring (C) will be contaminated, likewise the well. The well and spring are too near the source of pollution.

See that every foot of land is put to some use. Loafing land is generally the property of a loafing man; and there are so many indolent farmers, or those who work hard enough, but without management, to look ahead and plan for the years to come, in regard to crops. I tell you, I never saw a man (or woman, either) abandon the farm who didn't regret it afterward, if it was only a poor little scrap of a place. Cling to the farm you have and see what it will produce. Be a farmer, not merely a maverick.

There is much good gospel in this; but the tendencies that have resulted in the evils of which he complains have grown in spite of oceans of such good gospel and good preaching. The education of the boy is a collective function; and while the best farmers are likely to be home-taught, the only safe policy is for the state and nation to see to it that farmers are taught to farm in the rural schools.

# A Friendly Amphibian

By Dick Dickinson

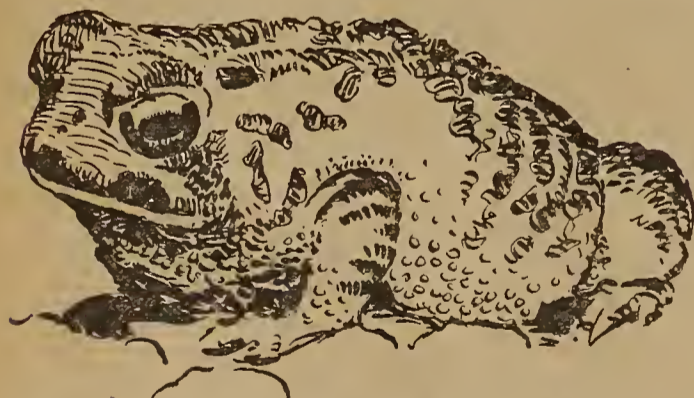

**R**AVAGES of insects upon crops and plants are the result of a disturbance in the economy of nature. If one portion of mankind didn't interfere with the scheme of things and kill the birds another portion of mankind wouldn't have to feed the insects.

In this adjustment of things next to the birds the farmer has no better friend than the common, repulsive toad. Within the limits of the insect world he is omnivorous—anything looks good enough for a dainty morsel. Apparently he is ungainly and sluggish in his movements, but he is able to catch enough of the winged creatures to furnish a good living. No insect, however large, is safe to come within the radius of his sticky tongue.

Two or three toads in an ordinary-sized garden, and you can dump the insecticides in the sea with the drugs for humans. It is an easy matter to provide them and encourage their presence. Many folks will not take readily to encouraging toads, because of a natural loathing for the animal. But by steeling yourself, taking for granted you are a woman, you can get accustomed to them. The toad, of whatever specie, is meek and harmless. Since he loves moist places, it is difficult to keep toads in a garden at all seasons, even though you

do not molest him. During wet seasons he is content to remain in a garden because it is a good hunting-ground, but in a dry spell he wants a cool, damp place to spend the day. He does most of his foraging at night.

Such a retreat can be easily provided for his toadship. A few old logs and boards piled in one corner of the garden will serve. Splash over them daily a pail or two of water to make the place inhabitable for your friend. This will keep him always on the job, ready to sally forth against the insect hordes. When

building the fence for your garden, it might be well to consider the toad. Don't build it so tight that he can't get inside and make a meal of the beetles and other pests if he chooses to do so.

On the other hand, if you appreciate his appetite as it deserves, you will make the fence with a board at the bottom. This is sufficient to hold them captive if the other conditions are suitable. As long as they have a damp place to sleep during the greater part of the hot days, they will not attempt to dig out. When such a fence is constructed, you can go toading. Visit the near-by pond and capture a half-dozen or more and turn them loose in the garden.

The toad is not even like some of the voracious insectivorous birds which insist on having a few cherries for a sauce to the grasshoppers and moths. He can't possibly be of any damage to the garden, unless perhaps some of the very cumbersome big fellows may occasionally crawl over the tender plants.

The toad is considerate also of your human friends. He rarely hangs around in the daytime to frighten them when you invite them into the

garden to view the flowers. Of course, it is much easier to encourage a few toads to live around a small flower-garden, and it is also easier to force them to remain inside. But it is not impossible to have them in a larger garden for vegetables. They are quite as beneficial there as elsewhere. It is less difficult, too, to provide a corner for their retreat during the day. A pile of logs is not unsightly in a truck-patch. The board at the bottom of the fence is not expensive, even if the garden patch is large. A half-dozen toads will easily pay for it.

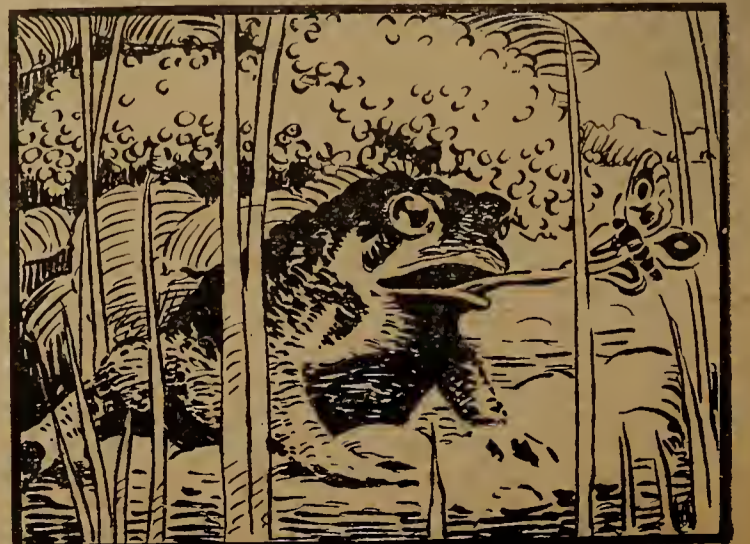

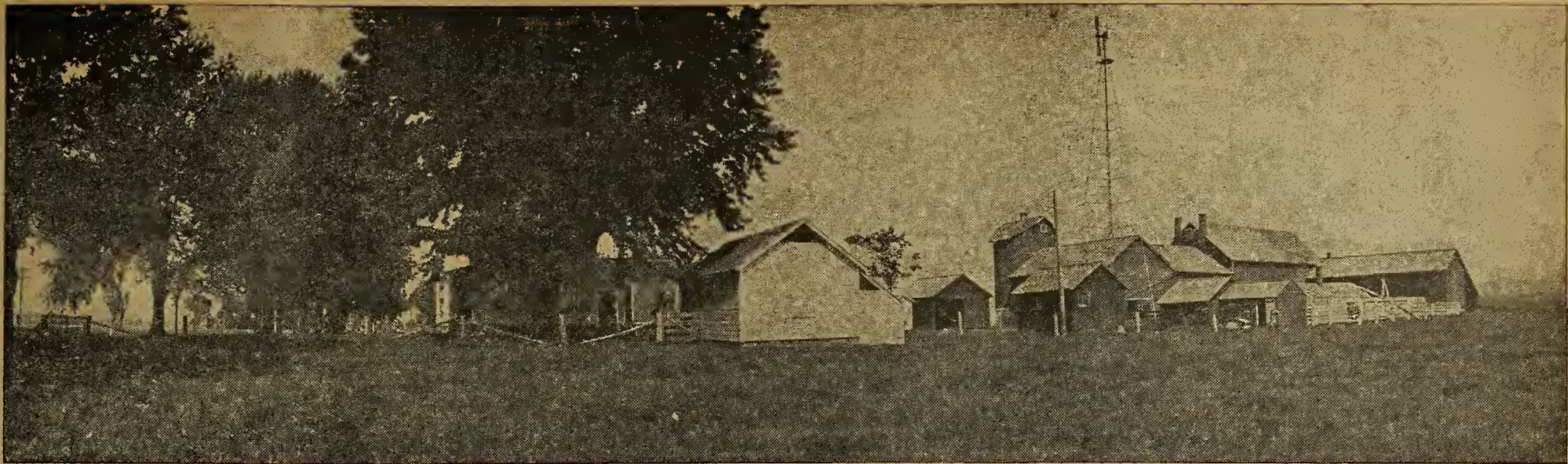

Mr. Griswold's Wisconsin farm. Good dairy cows have made it a profitable place

## Live-Stock Returns—A Comparison

In this issue dairy cattle and poultry are discussed. In the next, sheep and hogs will be considered. It is difficult to make comparisons, but such as may be drawn from a reading of these articles should be modified to meet the conditions of the reader who is expecting to put the ideas into practice.—EDITOR.

### Money in Milk and Butter

By H. D. Griswold

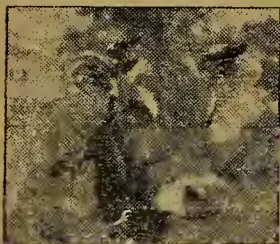

**T**HE good dairy cow has always been a source of profit and satisfaction to the farmer. But the average farmer does not appreciate the difference between good cows and poor cows, and consequently is careless in his selections and in his breeding and his care. Common cows are worth

about forty dollars per head. The farmer takes no pride in them, consequently handles them the easiest way. They cost him about forty dollars per year to feed, and bring him fifty or sixty dollars per year in milk product, and a five-dollar calf. The profit is small, and the farmer says there is nothing in it. I have an old German neighbor who can neither read nor write, nor talk in the English language. He has only three acres of land. He has two grade Jersey cows which he selected at a cost of seventy-five dollars each. They furnish the milk and cream used in a family of three persons; the rest of the milk product is sold at the creamery, and brings him an average of twenty dollars per month, or two hundred and forty dollars per year. The two calves bring him fifteen dollars per year, and the skim-milk which he has for his pigs and chickens he counts at fifteen dollars per year. The accounts thus stand as follows:

Cream sold at creamery.....	\$240.00
Two calves sold.....	15.00
Skim-milk.....	15.00
Milk used in family.....	18.00
<b>Total.....</b>	<b>\$288.00</b>

#### EXPENSES

Feed for one year, \$50 each.....	\$100.00
Depreciation in value of two cows.....	25.00
	<u>125.00</u>
Leaving a balance for his work of.....	\$163.00

He also has manure from the two cows sufficient to keep up the fertility of his three acres of land.

This shows what can be done in a small way. The man with a good-sized farm and more cows works to much better advantage in many ways. He can have his own bull. He can have a silo. He can have a warmer stable, because for two cows it is not profitable to keep a stable warm. Farmers should not depend on buying so many cows, but should raise their heifer calves. By keeping a full-blood dairy sire and raising their heifer calves, they can improve their own herds, keep up their required number and have some to sell. Where else can you get your grade cows? The farmer sells his poorest. You can raise a grade heifer to two years old for thirty-five dollars, that you would have to pay seventy dollars to buy, you have her in your hands to bring up properly, so that she is not stunted or dwarfed in her growth or development, and you get a splendid cow that you are proud of. The best results are not attained in working for milk alone, but the raising of the stock, and the sale of stock, combined with the milk product, is the most satisfactory, and the most profitable. Whatever line of stock the farmer keeps must be taken care of constantly and properly, or else he will receive no profit. To show you what can be done with small capital in the dairy business, I will give you my own experience. I started farming about thirty-five years ago with forty acres of land and one cow worth about twenty-five dollars. She had one calf, and went farrow. I sold these two, and bought two young cows. Later on I bought as I had the means and the opportunity. I soon found that the cows were the best paying of anything when I got good ones, but too many were poor. We then bought a full-blood Guernsey sire, and commenced to grade up our herd. The improvement was slow at first, but each year was better than the one before it, and by careful selection we got a herd of twenty-five cows that averaged four hundred and twenty-one pounds of butter per cow. Then we commenced to sell our grades and buy full-blood cows till to-day we have about sixty head of registered Guern-

seys. And so from a beginning of one cow worth \$25 we have to-day a herd worth several thousand dollars. The farm has been increased to eighty acres, and the fertility of the land has also been greatly increased. My four boys have all been to the University of Wisconsin, we have had the comforts and many of the luxuries of life, and the cows have paid the bills. We have now many men who are getting one hundred dollars and over per cow each year in this state. They are not common farmers. It is not chance work, but it is done by men who are willing to think and study and apply the up-to-date methods of care and feeding, and to do personal, every-day work. There are cows, and many of them, that make a man poor; that is to say, the hay and grain they eat, if sold, would bring more money than the milk product. The cow has been likened to a machine. She takes our hay and grain and pasture-grass and converts it into a finished product. Now, when we buy a machine for any specific purpose, we buy the best in the market. So with the cow. We want a cow of the dairy type that will make the most milk and butter-fat with the smallest amount of feed. We should feed her an abundance at all times—clean, sweet feed in the right proportion and in the proper variety. She should always be comfortable, have a warm, well-ventilated stable, not out in cold rains or frosts or cold winter weather. She does not carry a coating of fat, and she is very sensitive to the cold. Give her a good bed, keep her quiet, curry her off and in fly-time protect her by spraying or netting.

Cows as a rule increase in production up to about ten years of age, after that they fall off rapidly, although many cows keep up till much older, some even to fifteen and eighteen years; but, owing to accidents, failures to breed, and the like, the average working period is about eight years.

A good grade cow will cost seventy-five to one hundred dollars. She should give in one year seven thousand to eight thousand pounds of milk and 350 to 400 pounds of butter-fat. The average price, with us, for the last three years has been thirty cents per pound of butter-fat at the creamery. So thus your cow should bring you one hundred to one hundred and twenty dollars for cream. Breed her to a good bull, and the calf is worth ten dollars more. The skim-milk for a year is worth fifteen dollars. So you should realize in all one hundred and forty to one hundred and fifty dollars in a year. The cost of feed need not exceed fifty dollars per year, leaving you ninety to one hundred dollars per year for your work. Now this kind of work is being done in many cases, to my certain knowledge.

The two essential features to success are the good cow and the good man caring for the cow.

### Reasonable Poultry Profits

By Fred Grundy

**A**T PRESENT prices one hundred and fifty dollars would buy one hundred and fifty good, well-bred fowls—one hundred and fifty females, or ten males and one hundred and forty females.

There are three distinct methods of managing this number of fowls on the farm for profit.

The first is by hatching and raising chickens for market.

The second, producing high-class eggs only for market.

The third, producing both eggs and chicks for market.

The first method will require the use of ten males. The second, the use of two males. The third, the use of four males. In the first method all the fowls would range together. In the second, about fifteen selected females would be yarded to produce eggs for hatching next year's flock. The rest would be on range, without males, producing eggs for market. The poultry-keeper who is working for profit should know that hens and pullets producing eggs for market must not have any males with them. They will lay just as well, and the eggs keep better, and can be guaranteed.

I prefer the third method, because it gives me two strings to my bow. The breeding-stock is kept in a roomy yard, containing house and shed, and each bird has the flights of one wing cut off to prevent them from flying over the fence. One male is placed in the yard each day, the others being confined in roomy coops, the change being made after the fowls have gone to roost. When the hatching for the season is done, all males but one are disposed of and the yard thrown open. One male is kept in his coop to crow and keep the flock together, as a bell-cow holds a herd. The laying-stock has the range of the farm, is well fed, provided with plenty of nests, indoor and outdoor, and otherwise properly cared for.

In the markets eggs are usually graded "strictly firsts," these are usually very good and fairly fresh;

"seconds," these are fairly good, possibly some a little stale; "bakers' stock," eggs that are a little stale, but not bad. Prices range accordingly. Fresh eggs from hens without males can be guaranteed and "fancy," and the price tops all.

For these, local dealers in small towns rarely give over one-half to one cent a dozen more than for the common run, but retail dealers in the cities will give top price and something better when they can get them.

I went to my nearest city on a direct route, taking credentials along, and personally made arrangements with a reliable dealer to take my eggs, I guaranteeing them to him. All were sent to him in regular shipping-cases. Not a doubtful egg ever went to him, and he never ceased urging me to send him more.

Right here I wish to call attention to the article on Page 20, FARM AND FIRESIDE of July 10th, "The Farmer and the Camper." While camping on a Minnesota lake, I rowed two miles every morning for milk, for which we paid ten cents a quart. We paid fifty cents apiece for live chickens weighing about two pounds. Strictly fresh eggs cost us forty cents a dozen. Farms were on all sides, but at only one could we get eggs or chickens. If I were beginning again, I would buy ten or twenty acres near a summer resort and cater to the camper trade. One would not necessarily be limited to the camper trade, but the rest of the year he could go on with his business just as I did—ship to the nearest city, or sell in the local market. As I have said, however, I would not be content to accept the low prices for eggs and stock that any small dealer might see fit to offer. I would get nearer the consumer—supply him direct if I could.



Making the corn pay bigger dividends

And this means that my eggs would be guaranteed, and my stock high class. Never would I ship a fertile egg, nor supply one to a local customer. Even with the greatest care it is possible that in gathering the eggs one might be overlooked and a hen sit on it all night, or that a hen might lay so late in the evening that she would remain on the nest all night. The warmth would injure a fertile egg so that when opened a few days later it would have a stale appearance, or it might have a few slight red streaks on the yolk. In either case such an egg would injure my business a thousand times more than its value. To preclude the possibility of such injury all eggs must be infertile, no males being allowed with the hens at any time.

It is to the poultryman's interest to keep his stock up to the best type, healthy and vigorous all the time, because there is most profit in such a course. This means, of course, that only strong, vigorous stock must be used for breeding purposes. Quite often the strong, vigorous birds are a little coarse in color. I never lost anything by preferring vigor to fancy color.

Prices one has to pay for poultry-food vary greatly, and, of course, cut a figure in the profits. I have bought corn for thirty-five cents, and again had to pay as high as eighty-five cents a bushel. One year I paid sixty cents a bushel for wheat, and another year \$1.40. As poultry-food I consider corn actually worth more than wheat, but it cannot be fed alone. Wheat, or wheat products, must be used with it to get the best results in eggs or growth. Prices of poultry and eggs do not rise immediately with the price of grain, because when grain prices rise people then begin to cut down the size of

[CONCLUDED ON PAGE 16]

Live Stock and Dairy

Cattle-Market Prospects

THE first great thing for a progressive farmer to learn is his business, and to do so he must be in daily touch with the markets. The business end is a life work and a brainy work. These are fast times we live in and success is generally, I am sorry to say, measured by wealth. No legitimate farmer will ever get rich quick, because any farmer who has grasped the fundamental principles of farming realizes that the way to a comfortable home and competency is to cut out, as much as possible, speculation in everything appertaining to the farm. He ought to plan out a definite goal to work to, and that definite goal is a life work. For it ought to be: "Make the farm produce more." Feed the farm and the farm will feed you. This means keeping live stock on the farm. I am fully aware that in many cases live stock do not leave a direct profit, but they always leave an indirect one, and that's the one the business farmer must look after. This has been hammered out year after year by agricultural papers—and how slow the average farmer is to grasp it! What is going to make a change? "Necessity." We are now up against high-priced land and a great shortage of beef and dairy cattle to meet the demands of our fast-growing nation.

Stock cattle are high now, but would have been much higher but for this dry year. No man can foretell what the market will be six months from now, but it needs no prophet to see that, owing to the dry weather and the great shortage of roughage all over this country, the man who uses a little foresight and saves his corn-fodder, either siloed or shocked, or both, and winters as many good young cattle as possible, runs no chance of loss.

Many farmers who cut up corn-fodder, intending merely to winter the cattle, should think things over carefully, make a careful estimate of the amount of live stock they intend to keep and the feed on hand, and be prepared to carry them through to May 15, 1912. Don't buy too early. Remember the cattle bought in the fall with a little flesh on will shrink and lose weight if fed only rough feed in the winter.

As a business proposition, farmers should weigh the rough feed. How many thousand farmers feed their cattle all they can eat and waste through the winter months up to March, and then let the cattle live on wind and water through the spring at the very time they need the feed most, and lose, through lack of a little time and judgment, the profit?

Good fat cattle are now selling well and will go higher. Every dog has his day. We have had high corn and hogs, and now, that the country is plowed up, it is only natural we should have high cattle and hay for a few years. W. S. A. SMITH, Iowa.

Hogs and Market Prices

THE fluctuations of the market prices are regarded by a fair percentage of the producers to have only a partial apparent cause or to be controlled by the killing interests. These incorrect impressions are due to a lack of a full understanding of the factors which do control the markets. It is much a case of supply and demand, but each has many elements to influence it. Let us first consider the question of supply, and use the current hog market as an example.

This season, contrary to the usual condition, the prices have been on a general downward trend during the spring and early summer months, but the reaction came and the rising market arrived a bit late. This abnormal condition was largely due to the steady, heavy marketing all spring. For the first seven months of this year there was an increase of twenty-five per cent. in the receipts over those of the corresponding period last year at the five western markets.

This held the market down until August, when the supply had been pretty well exhausted, and the shrinky grass-fat shipments usually received at that time were either lacking or came in in hard flesh due to the dry pastures. All along there was a steady, healthy demand. These effected an upturn in the August prices which was larger than yards circles expected.

The factors controlling the supply of this year's crop, however, are quite different. There are at the present time three important elements which will affect the supply later on. The first of these is a large crop of pigs. The boom prices for the past two years have induced farmers to increase the size of their herds and the past spring has seemed to have been favorable for the saving of a large percentage of the pigs farrowed, hence the large number now on hand. The second of these is the prospect of a good corn crop. The injurious effect of the mid-summer drought was, for the most part, counteracted by the general heavy rains the fore part of August. The third is the inclination to put the little pigs on the market now, or to sell them later before a good weight is reached.

There is sure to be a decided decline in prices when the large supply soon to go into the feed-lots begins to move to market. Doubtless the decline during the coming fall and winter months will be greater than that of the corresponding time last year. But the amount of decline will be governed somewhat by the way in which the crop is marketed. Such forecasts as a five-cent market at the beginning of the heavy run and another of four cents at the low point during the winter will probably prove to be wrong, but under certain combinations of conditions may possibly prove true.

During the latter part of July and the first part of August large numbers of little pigs went to the yards, owing in some cases to the shortage of pasture and in others to the necessity of getting a little cash which under ordinary conditions the banks are willing to furnish. These little fellows have but little effect on the market, as their small size makes them such a small percentage of the stuff that goes over the scales. Every pig sold early means one less fat hog later on, so the larger the number of pigs sold now, the smaller will be the supply during the winter and consequently the better the price.

If the present attitude of the banks in refusing to loan money continues for any great length of time, many farmers will be forced to sell their half-grown stuff to pay their debts. Such a condition would benefit the packer, for the prices would go down in proportion to the number forced to market.

It will be seen that there are numerous conditions, each having its effect in governing the supply of the hog market. It is probable that no extreme situations will really come about this fall and winter, but an average condition will no doubt be forthcoming and one can expect to see a fair consignment of light stuff during the fall and a rather heavy run of finished hogs lasting for a long period quotable at the lowest figures reached in five or six years—a price close to the five-cent mark.

LLOYD K. BROWN, South Dakota.

Sheep-Market Facts

THE most notable feature of the sheep market seems to be its steady, if slow, upward tendency over a long period of time, and this in face of an immense increase in the supply and the near extinction of the export trade. During the first eight months of the present year the receipts of sheep and lambs at the six principal western markets were 6,858,000; during the same period of 1910, 5,703,000, an increase of 1,065,000. The average prices of good sheep and lambs in Chicago in the same period in 1911 were: Sheep, about \$4.00; lambs, \$6.40; in 1901, sheep, \$3.45; lambs, \$4.70. The average prices for the ten years were, for sheep, \$4.20; lambs, \$6.10. These averages do not, however, tell the story of the vast numbers of unripe lambs and sheep that were at times forced on the markets, or of the uniformity with which prime lots of lambs ranged

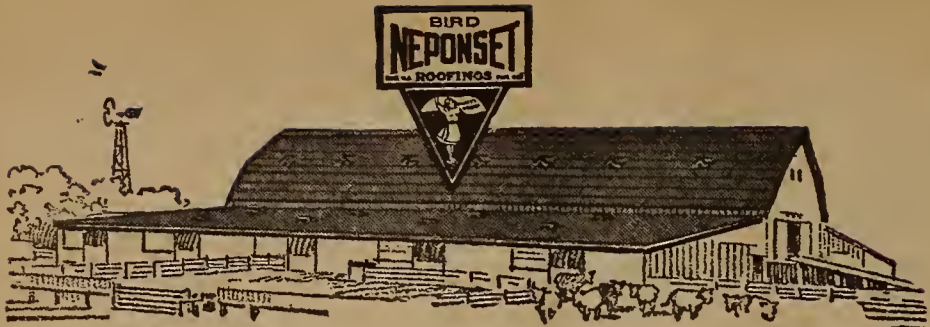

Biggest Stock Barn in Minnesota

shown above, is roofed with NEPONSET Paroid Roofing. Your barn also is worthy of the best roof you can buy.

NEPONSET

Paroid Roofing

Is the Real Rival of the Best Shingles

It costs less to buy and less to lay. It wears as long as old-fashioned shingles. Recent photographs of roofs 13 years old prove it.

NEPONSET Paroid costs a little more than any other prepared roofing made, yet we don't claim it to be the only good roofing. We simply know that NEPONSET Paroid lasts as shingles used to last—when shingles were good—and that the majority of farmers are buying NEPONSET Paroid to make certain of longest wear and a big saving in the end and it also adds real fire protection.

NEPONSET Proslate is the NEPONSET Roofing for houses; NEPONSET Red Rope for low cost construction.

The NEPONSET dealer in your town has a full line of NEPONSET Roofings. If you don't know him, write us.

F. W. BIRD & SON, (Established 1795) 59 Neponset Street, East Walpole, Mass. New York Chicago Washington Portland, Ore. San Francisco Hamilton, Ont. Winnipeg Montreal St. John

STOP! STOP! STOP!

Thirty Days Trial of

United States Bonded Engine.

Burns gas, gasoline, kerosene, distillate. Consider these 12—Advantages—12

- 1st, Pays for itself in fuel saving in short time.
- 2nd, No violent vibration.
- 3rd, Greatly reduced bulk.
- 4th, Easily portable, mounted anywhere.
- 5th, Every engine part and horse power guaranteed.
- 6th, Absolutely frost proof.
- 7th, Positively most economical running engine made.
- 8th, Only engine with pulley on both sides.
- 9th, Small pulley on cam shaft, for very slow machine.
- 10th, Perfect lubrication, cooling & ignition.
- 11th, Lowest cost engine in the world.
- 12th, Made by reputable firm, 60 years in business.

2 to 50 H. P. Wonderful New Pumping Engine. Send postal today for Illustrated Catalog. United States Engine Works 1507 Canal St., Chicago, Ill.

**Ann Arbor**  
THE BALER FOR BUSINESS

Whether you want to bale hay, alfalfa, timothy or sorghum—12 tons a day or 70 tons—get a genuine Ann Arbor Baler. Steel or wood frame—horse, belt power or traction type. We guarantee greater capacity, endurance, economy. Guarantee is positive and binding, backed by world's records and world's largest exclusive hay press factory. Ann Arbor Balers cost no more, last longer, and are cheaper in the long run. Write for Free printed matter and prices. ANN ARBOR MACHINE CO., Box 408 Ann Arbor, Mich.

Fine Live Stock Book Free!



Dr. David Roberts' Practical Home Veterinarian, 184 large pages, illustrated, is now Free to Live Stock Owners.

Gives symptoms, diseases and treatments for all live stock and poultry, the result of Dr. Roberts' life experience as veterinarian and live stock specialist. Apply at your drug store and get a copy free. If not there, send 10c in stamps for postage and we will send direct.

DR. DAVID ROBERTS VETERINARY COMPANY 50 Grand Avenue, Waukesha, Wis.

NEWTON'S HEAVE COUGH, DISTEMPER AND INDIGESTION CURE

The first or second \$1.00 can cures Heaves. The third can is guaranteed to cure or money refunded.



The Standard Veterinary Remedy. Makes the Horse Strong and Willing to Work. CURES HEAVES BY CORRECTING THE CAUSE which is Indigestion. Send for booklet "Horse Troubles." Explains fully about the Wind, Throat, Stomach and Blood. Newton's Sassafor colic, a dultor mare in foal. A GRAND CONDITIONER AND WORM EXPELLER \$1.00 a can at dealers, or express prepaid THE NEWTON REMEDY CO., Toledo, Ohio

PATENTS SECURED OR FEE RETURNED.

Free report as to patentability. Illustrated Guide Book, and List of Inventions Wanted, sent free. VICTOR J. EVANS & CO., WASHINGTON, D. C.

The Best Farm Locations

To the man looking for a home where productive lands, favorable climate and abundant rainfall make the best paying farm locations in America the Southeast is now the unequalled section. Land from \$10 to \$50 an acre near the heart of the country and close to the best markets. The largest returns from alfalfa and other hay, wheat, corn and all truck crops. Land unsurpassed for live stock and poultry raising and dairying. For fruit growing no region is more profitable.

Beef and pork are produced at from 3 to 4 cents a pound. Experts say that no other section can compete with the South in stock raising. Our mountain and Piedmont regions will be the most successful dairy districts of the country. As many as 6 crops of alfalfa a season are harvested. Other hay crops are also large. Hay brings \$12 to \$22 a ton. The Southeast is rapidly coming to the front as a corn section. Our States will grow 600,000,000 bushels this year. Good farmers can get the largest yield possible anywhere, as returns prove. The South is the leading section for truck farming of all kinds, and growers make the largest profits.

THE SOUTHEAST HAS LOCATIONS FOR EVERY KIND OF FARMING

The climate assures not only the finest results for intelligent agriculture, but makes the region unsurpassed as a healthful and pleasant home location. The Southeast is an Open Winter country and its summers are enjoyable. You will be able to locate where there are good schools, church facilities, good roads, rural delivery and all other advantages.

The Southern Railway and associated lines will help you to find the location you desire. Our several publications, free on application, will tell you about the region where the greatest farm opportunities await you. Address

M. V. RICHARDS, Land and Industrial Agent, Southern Railway, 1330 Pennsylvania Ave., Washington, D. C.

DE LAVAL CREAM SEPARATORS

Skim cleanest—turn easiest—are simplest—most sanitary—last longest

The De Laval Separator Co. NEW YORK CHICAGO SAN FRANCISCO SEATTLE MONTREAL WINNIPEG

## PAID HIM TO CHOOSE SHARPLES Tubular Cream Separator

Has anyone tried to convince you that disks or other contraptions are needed in modern cream separators? If so, read this:

**West Newfield, Me.**  
**The Sharples Separator Co.**  
 The Tubular Separator I bought of you paid for itself in six months with only six cows and left a balance to the credit of the Tubular of \$14.00. People came to my house, saw the Tubular at work, and purchased a Tubular for themselves; others that had separators of another make, after seeing the Tubular at work and the ease with which the bowl was cleaned, traded their separators for a Tubular. **GEO. T. WILSON.**

**Geo. T. Wilson personally appeared before me and declared the above statements to be the fact.**  
**Luther E. Sanborn, Justice of the Peace.**

It paid Mr. Wilson to choose the Tubular, for Tubulars have twice the skimming force of others and repeatedly pay for themselves by saving what others lose. Dairy Tubulars contain nodisks—wear a lifetime—are guaranteed forever by America's oldest and world's biggest separator concern. You will finally have a Tubular. Buy The World's Best first. Save yourself the expense of discarding some cheap or complicated separator. Other separators taken in exchange. Write for free trial and catalog 112.



**30 Yrs**  
**THE SHARPLES SEPARATOR CO.**  
 WEST CHESTER, PA.  
 Chicago, Ill., San Francisco, Cal., Portland, Ore., Toronto, Can., Winnipeg, Can.

## ONLY \$10. CASH

Balance \$5 a month, buys this three-year GUARANTEED Buggy. Write today for our FREE CATALOGUE



of Buggies, Surreys, Spring and Farm Wagons. Century Mfg. Co., Dept. 629 East St. Louis, Ill. Catalogue Free.

## FREE Literature

will be sent to anyone interested in the wonderful Sacramento Valley, the richest valley in the world. Unlimited opportunities. Thousands of acres available at right prices. The place for the man wanting a home in the finest climate on earth. No lands for sale; organized to give reliable information. Sacramento Valley Development Association, SACRAMENTO, California

## Steel Wheels

will make your old farm wagon as good as new. Save money because they never need repairs. Write for our big free book telling all about them and how they pay. Empire Mfg. Co., Box 68-O, Quincy, Ill. BOOK FREE



## ELECTRIC Steel Wheels

Fit all running gears. Get a new wagon just by buying wheels. Unbreakable, almost everlasting. All heights and tire widths. Also new Electric Handy Wagons. Write for book on "How to Make Old Wagons New." Free. ELECTRIC WHEEL CO., Box 13, Quincy, Ill.



## Farmers' Handy Wagon at a Low Price

Absolutely the best wagon built for every kind of heavy teaming. Low steel wheels, wide tires. Will last a lifetime without repairs.



**STEEL WHEELS** for farm wagons—any size to fit any axle. Send for our free booklet before you buy a wagon or a set of wheels. **EMPIRE MFG. CO., Box 68-L, Quincy, Ill.**

It is to your advantage to mention Farm and Fireside in writing to advertisers. Farm and Fireside folks get the very best attention.

## Get Ready for Fairs Show the Best

There can be but **One Best**

Why lose profits breeding and feeding scrub hogs? Two of our O.I.C. hogs weighed 280 lb. We are headquarters for breeders. Will send sample pair of our famous **O.I.C. Hogs**



on time, and give agency to first applicant. We are originators, most extensive breeders and shippers of thoroughbred swine in the world and hold the unparalleled record of having been established 47 years without losing a single hog by cholera or any contagious disease. **The L. B. Silver Co.** 1101 Citizens Bldg. Cleveland, Ohio.

We want to mail you our free book, "The Hog From Birth to Sale."

Send us your name **FREE**

Any owner of live stock, on request, will receive by return mail, charges paid, with no obligations whatever, 8 oz. sample package of the celebrated Silver Liva Stock Powder, the well-known disease preventive and conditioner, with directions for its use.

U. S. Gov't inspected herd.

between \$7.00 and \$7.75, and sheep from \$4.75 to \$5.25. During the last two weeks of August new life became apparent in the market for fat sheep and yearlings, while prices for lambs fell off from fifteen to fifty cents.

Recent market returns seem to confirm the idea, that this plethora of poor stuff is about exhausted, and that it is not at all likely to recur, at all events for the present, and that very healthy and satisfactory conditions may now be looked for, though November is likely to retain its reputation as the wakening up time of the fat-lamb trade. As regards wool, the fear of any immediate change in the tariff being removed, the indications are in favor of a steady demand and fair prices. Boston reports are very encouraging.

The lamb crop of 1910 over most of the states this year's crop of hay was good and late rains produced a fair supply of grass in Idaho, Montana and Wyoming, so it is probable that much home feeding will be done in those states, and many feeders are said to be leaving Colorado to locate in one or other of them. For these reasons, among others, the *Breeders' Gazette* predicts as follows: "Both sheep and lambs will be scarce and high compared with last winter. . . . Consumption is broad, and even at materially higher prices than the market afforded last winter mutton will be wanted." A strong and concerted movement among leading business men in those states is being organized to offer inducements to settlers to improve their methods of farming and to raise cattle and sheep where they are rapidly superseding the old open-range breeders and feeders. Good markets are opening for them in the big cities of the Northwest, and in consequence a large falling off of both fat and feeder sheep and lambs coming from that section of the country to Omaha, Chicago and other markets of the Middle West may be looked for.

If these anticipated changes materialize, the supply of both sheep and lambs of high finish and of the desired medium weights will offer golden opportunities to the farmers of the Middle West and of the East to fill a want, which is all the time growing, by breeding and feeding animals of that class. With a string of such markets as Chicago, Kansas City, St. Joe, Buffalo and Louisville, in the two latter of which prices for sheep and lambs have of late been nearly as high as those in the greater markets, no fears need be entertained as to the realization of paying prices for all good stuff, and much of the loss unavoidable in long hauls will be done away with.

Readers of FARM AND FIRESIDE who are interested in sheep and lambs—and I know they are numerous and hope they will increase in numbers—will have observed that a great preference is always shown by me for Shropshires, especially for the breeding of lambs for the early spring and the fall markets. That preference is founded on personal experience; but the following statement of facts goes further than I have ventured in claiming a special fecundity for that breed. It is made by Mr. Mansell, a great English authority: "One hundred and fifty to 175 lambs to 100 ewes are about the usual average, and, in 1896, 11,666 ewes reared 168 lambs per 100 ewes." To my eyes the thoroughbred "Shrops" in this country always look a little better than those I used to handle over there, and I can see no reason why they should not display as great virtues in the line so urgently brought to the attention of American mothers by Colonel Roosevelt. A great falling off in the export of this class of sheep is noted, and the reason is given in the number of good flocks of this breed already established here and in Canada. In this may be found also a reason why it is no longer necessary for the seeker after thoroughbred rams for crossing with good grade ewes, to pay excessive prices, or to go far from home to fill his needs. It is not too late even now to get a little flock together of good grade ewes and a thoroughbred Shropshire ram, and so to be able to jump into the band-wagon of good prices for sixty to seventy pound lambs early in next June. To do this safely and economically, good forage crops of the right sort of rape, rye or vetches should be sown at once. Details as to these crops for those who are unacquainted with them can be found in FARM AND FIRESIDE (November 23, 1910, page 12). They should be ready for the lambs when they come out of the yards. They will be looking for their green meat by then.

**Easy Sale**

About the middle of August quite a strengthening became visible in the sheep market, and especially with regard to lambs. Even culls were disposed of without much trouble. And though there was no great rise in prices, less discrimination was observed as to weights and quality. Quite a lively call, too, developed for feeders and breeding-ewes; all of which looks well for the fall and winter trade.

**Wool**

August reports from the West and South indicated a fair amount of wool sales, some very large clips going to Boston, where wool was needed for immediate delivery to some of the mills. The actual prices paid are

hard to get at, but they appear to have ranged between twelve and one half and eighteen cents. It is said that eastern wool-growers are holding out for higher prices, but many southern and western men are driven to sell for financial reasons. The vetoing of the wool bill will, at all events, for the present, tend to put some life into the trade.

**Sheep and the Silo**

The value of silage as the cheapest and best succulent for cattle and hogs is fully established.

For sheep, and especially for lambs, its very cheapness is apt to tempt to its overuse. The successful feeding of lambs depends largely on their being offered great variety of food while in the yards. They find it for themselves when at pasture. This also applies to ewes while suckling.

Much damage is often done by careless feeding of sour or moldy silage; a few roots—turnips, mangels, beets, good bright timothy or clover hay, with bran and linseed-oil meal with their grain ration, are the safe and well-proved producers of healthy ewes and prime lambs.

**JOHN PICKERING ROSS, Illinois.**

**The Pacific Coast Meat Demand**

FOR the past two years there has been a small demand by the meat-packing interests on the Pacific Coast for hogs and cattle on the east side of the Rockies. But till this season it was an experiment, both with the Pacific buyers and the stockmen selling to them, but from the volume of trade going west this fall, instead of east, it looks as though the experiment was a success and that a healthy, steady Pacific Coast market has been developed for our middle-western stock.

This is a big step forward for all the livestock growers of America. It is a direct benefit to the cattle and hog growers located between the Missouri River and the Rocky Mountains, for it gives them two competing markets, each anxious for their stock, and this year the competition between the Chicago and the Pacific Coast interests for the large shipments of fat range cattle has been particularly keen. Often a single shipment has consisted of two and three train-loads of cattle. This is an indirect benefit, but nonetheless a sure one to the cattle and hog growers east as far as Ohio and Pennsylvania, for it takes the big run of western grass cattle out of Chicago, therefore out of competition with the same grade of killing cattle the eastern farm has. This decreases the supply at Chicago, which will inevitably raise the price, and the eastern growers are directly benefited by the raise.

The hogs which go west instead of east are picked up in the eastern part of the two Dakotas and in Nebraska by buyers who buy direct from the farmers and from the local shippers. They accumulate their purchases for a week at some advantageous railroad town and then load a full train-load of double-deck cars of hogs and send them west over the Rockies.

This new outlet is perceptibly telling in the receipts at the Missouri River markets and is helping to maintain the prices at a high level, for these Pacific buyers are paying full market prices for the hogs in the country.

The sheep which the Pacific Coast packers are buying are being taken from the ranges and farms of Idaho, Oregon and Washington, and this again lessens the enormous runs of sheep at the big centers.

The Pacific Coast population is growing rapidly and the people there must be fed, and it will be a long time, if ever, before they will be in any way self-supporting in their meat demand and supply. So the outlook for the meat-growers east of the Rockies and west of the Missouri River is exceedingly bright.

There has never been a better time for the western farmer to stock up with the best of good cattle and hogs and stay in the business, and the eastern farmer as well has the same good prospect; for the overwhelming runs of range cattle at Chicago are a thing of the past. The Chicago market will inevitably be better on account of this Pacific Coast outlet. **PAUL H. BROWN.**

**Treatment for Sore Mouth**

A NEW YORK subscriber asks what can be done for a horse which has a very sore mouth. A rubber bit is being used and the animal is very carefully handled. The sensitive condition is due to the previous use of a jagged-edged bit when under a former owner of the horse.

The rubber bit is all right to use, yet I have sometimes found a plain snaffle bit well wound with linen cloth preferable when several thicknesses are used over the bit and at night washing it in clean water. Then the next morning, before putting it on the horse, wet it with a solution made by dissolving an ounce of borax in a pint of water that is near the boiling-point, then add about two tablespoonfuls of strained honey. This makes an excellent healing agent for a sore mouth and being on the bit is constantly being squeezed out in the mouth and comes in contact with the sore and, more than this, is relished by the horse. **C. D. SMEAD,**



Digging asphalt from Trinidad Lake

## Time-and-weather test is the real roofing test.

You want to be sure before you buy that your roofing will stand this vital test. The only way you can be sure is to know what the roofing is made of.

# Genasco

the Trinidad-Lake-Asphalt Roofing

is free from mystery and deception. It has the life that only natural asphalt can give roofing to make it thoroughly and permanently waterproof.

The natural oils in Trinidad Lake Asphalt give it this resisting life; and they do not dry out of Genasco like the volatile oils in artificial asphalt roofings, which leave them to crack, crumble, and leak.

Genasco Roofing resists rain, snow, sun, wind, heat, and cold—and it lasts.

The Kant-leak Kleet not only makes seams absolutely water-tight without cement—it prevents nail-leaks, and gives the roof an attractive finish.

Ask your dealer for Genasco mineral or smooth surface Roofings with Kant-leak Kleets packed in the roll. Fully guaranteed. Write us for samples and the Good Roof Guide Book.



**The Barber Asphalt Paving Company**  
 Largest producers of asphalt, and largest manufacturers of ready roofing in the world.

**Philadelphia**  
 New York San Francisco Chicago

Cross-section Genasco Smooth-surface Roofing  
 Trinidad Lake Asphalt  
 Asphalt-saturated Wool Felt  
 Trinidad Lake Asphalt

## LABOR SAVING BARN EQUIPMENT

Learn how you can save unnecessary "hired hand" expense and do your barn work quicker. Cleaner and better with Star (H. H. & F.) Barn Equipment (Litter and Feed Carriers, Stalls and Stanchions.) Draw a rough sketch of your barn layout with dimensions, send to us with your name and address, and we will send you estimates and **FREE PLANS** full particulars. Whether you are in the market now or not, this experiment costs you nothing. Find out what you can save each season with Star (H. H. & F.) Equipment. Write us today. **HUNT-HELM-FERRIS & CO.** 114 Hunt St. (11) Harvard, Ill.



## CORN HARVESTER

Something new—Cuts complete shock without stopping team. Makes shock row 60 to 80 rods apart and leaves the land clear for seeding or plowing—just what the farmer has been needing. Sold direct. They are guaranteed. Price \$20.00. Write for circulars. **CORN KING HARVESTER CO., Box 1536, Salina, Kansas.**

**WHEELS, FREIGHT PAID, \$8.75** for 4 Buggy Wheels, Steel Tires. With Rubber Tires, \$13.45. Rehubbing your wheels, \$10.30. 1 manufacture wheels 3/4 to 4 in. tread. Buggy Tops, \$8.50; Shafts, \$2.10. Learn how to buy direct. Catalog free. Repair wheels \$5.95. Wagon Umbrella Free. F. F. BOOR, Cin'tl, O.

## PATENT SECURED OR FEE RETURNED.

Free Patent Book, Selling Guide and List of Buyers and Manufacturers of Inventions. Advice Free. Send sketch. **FARNHAM & SUES, Attys., 562 F. St., Washington, D. C.**

## H. P. Farm Engine \$49.50

1/2 Kerosene-Gasoline

Greatest value ever offered in a 4 cycle water-cooled farm engine. Runs any kind of machinery—pumps—saws—separators—feed grinders—water systems—electric light outfits, etc.

4 & 6 h. p. sizes at proportionate prices. Also complete line of 2 cycle engines. Very simple. Uses little fuel. Best material and workmanship. Made to last a lifetime. Shipped complete all ready to run. No extras to buy. Guaranteed by a big responsible concern. Write for catalog TODAY and ask about **30 Day Trial Offer**

**Gray Motor Co.**  
 Building  
 967 U. S. Motors  
 Detroit, Mich.





## Good Light

makes night work easier. Rayo lanterns give the most light possible for the oil used.

Rayo Lanterns will not blow or jar out.

They are easy to clean. Easy to fill and light. Made to stand hard wear.

You can get Rayo Lanterns in various sizes, finishes and styles. Each is the best you can buy of its particular kind.

All Rayo lanterns are equipped with selected Rayo globes, clear, red or green, as desired, and wicks are inserted in the burners, ready to light.

Dealers everywhere; or write for descriptive circular direct to any agency of the

Standard Oil Company  
(Incorporated)



## Fastest Hay Press

Greater capacity is guaranteed in all Spencer Presses. The guarantee with our Alligator Press says "22 tons in 10 hours or no pay." Large feed capacity—smooth and compact bales, uniform in size. Load full weight into cars. All Spencer Presses are biggest money makers because they give greatest capacity at smallest operating and repair cost. Write today for Free Illustrated catalog L. L. describing full line.

J. A. SPENCER  
115 William St., Dwight, Ill.



It is to your advantage to mention Farm and Fireside in writing to advertisers. Farm and Fireside folks get the very best attention.

## GARDENING

By T. GREINER

### Home-Grown Sweets

It is more than imagination, more than the poetry of the thing, that makes some of the vegetables that come from our own garden taste better to us than those obtained in the markets. I am not living in a water-melon country. Often when we want water-melon we have to buy, and sometimes we get hold of a fairly good one, and we do enjoy it. But I do not remember ever having had a purchased melon that tasted as good and was relished as much by every member of the family as the small or medium-sized Early Harris I have been bringing in from my own garden lately. I have other varieties, and they are just as good and as "real" sweet as the Harris. It is not so much in the variety as in the fact that they are gathered just at the proper stage of maturity. We can let the melons get ripe on the vines and have them just right, when brought in fresh from the garden.

The home grower, most likely has very little, if any, experience in growing and harvesting watermelons. He is afraid of taking a fine specimen off the vines, as it may not be ripe enough. How can he tell? By experience, practice, observation. Some, or most, growers tell by the sound when lightly tapping the melon. My hearing is not acute enough. I have to tell by sight, and by observing the general appearance of the specimen. The dying and drying of the tendril opposite the stem of melon is a good sign, although not exactly infallible. The best indication, however, is the change in the appearance of the underside of melon, where the melon is in contact with the soil, and in the color of the whole melon. This is hard to describe, but it tells its own plain story to the experienced. You have to try. You may occasionally spoil a melon. It cannot be helped. You can spoil a melon by leaving it on too long just as well as by cutting it too soon.

### Saving After Production

The season of production will soon be at an end. Our efforts must be mainly directed upon the saving and making best use of the crops. We should not let "the frost get on the pumpkins" nor squashes. Some of our good vegetables are easily hurt. Sweet potatoes cannot stand the lightest touch of the frosty breath of fall. In fact, they must be handled quite gingerly in all respects, and protected from rough handling during harvest and storage. That is also the case with pumpkins and especially squashes. Every touch of frost, every bruise, starts decay. We always "handle with extreme care." Good pie pumpkins are quite a salable com-

modity in this as in many other localities. They bring as much as winter squashes. But I gather everything, ripe or green. Even the smallest and greenest pumpkins and squashes have some value for feeding. Sometimes I cook or steam some of the pumpkins and squashes that are not salable to mix with meals for fattening fowls. Any specimens that were in the least frost-bitten are fed first. The balance are stored under shelter, and covered at the approach of cold weather. If we have winter squashes above our own home demand, we try to sell them to grocers or private consumers as soon as possible.

There is always a good demand for them, and for pumpkins also, just before Thanksgiving and during the holidays. In a small way, these crops are quite profitable, especially when they can be sold direct to consumers in retail.

### Prolong the Tomato Season

Tomatoes seem to be especially good this year, far better than we had the same varieties last year, and everyone seems to look at the matter in this same light.

This is undoubtedly due to the warm summer we are having this year. Tomatoes are so good that I already hate to note the approach of fall and the end of the tomato season. Sometimes we have just a light touch of frost at about the time of the equinox, sufficient to scorch the tops or most exposed parts of the plants, but leaving the balance of the vines, with most of the fruits that were hidden under the foliage, unharmed so that in the nice warm days to follow we can continue gathering nice ripe tomatoes. If we have but a few vines, we can easily give them a light covering of paper, cloth, hay, or anything else that will give a little protection during the first fall frost or two. I usually pull up a few plants that are well loaded with half-matured fruits and either put them in a cold-frame, on a little straw, covering the frame with sashes, or hang them up by the roots under shelter where safe from frost. The specimens continue to ripen and are used for the table, sometimes for many weeks afterward. Sometimes I have wrapped some half-ripe specimens in tissue paper and packed them in boxes, bedded in oats. Of course, we also can a good lot of tomatoes. They have usually (with the exception of last season) kept well and seemed to be as good as tomatoes taken right out of the patch and cooked. We all like tomatoes so well that it pays us to take some pains in the direction of prolonging the season.

### Red-Shouldered Hawk

It is a beautiful sight to see these large hawks mounting the vaulted blue in wide, sweeping circles, turn after turn, without so much as the flap of a wing. They mount up as eagles, and then when they call back defiance to all the world with their loud, piercing cry of "Keer, keer," we look up with envy and say, "If man could only fly!"



This common hawk is often incorrectly called "hen hawk." The United States Department of Agriculture says it is very valuable to the farmer, for it feeds on mice, birds, snakes, frogs, fish, grasshoppers, spiders, centipedes, crawfish, earthworms and snails. Ninety per cent. of its food consists of injurious mammals and insects, and hardly one and one-half per cent. of poultry and game. The report further says that "A pair of these birds bred for successive years within a few hundreds yards of a poultry-farm containing eight hundred young chickens and four hundred ducks, and the owner never saw them attempt to catch a fowl."

This valuable bird is often ruthlessly shot because it is a "hawk," and has its nest robbed of eggs or young for the same reason.

H. W. WEISGERBER.

# Thor

The Motorcycle For the Farm

Here's a means of transportation that will save you time and furnish an endless source of enjoyment. Think of riding five miles to town over the roughest roads in ten minutes! Why, you can do twice as much work with less effort if you own a Thor. Tell your friends to get a Thor and form parties for cross country trips. But be sure to tell them "THOR" for the Thor is the motorcycle with the free engine clutch, which enables you to stop while the motor keeps on running. The Thor won every endurance contest the last two seasons and stands alone as the fastest and most reliable motorcycle made. 4 handsome models await your approval. Four (4) Horse Power Single Cylinder, either Chain or Belt drive.

AURORA AUTOMATIC MACHINERY COMPANY, Dept. 18, 1309 Michigan Ave., Chicago, Ill.

BOOK SENT FREE ON REQUEST  
This book describes in detail the wonders of the Thor. Write for one today. It's FREE to you. Write now.

## Let Galloway Save You \$25.00 to \$40.00 on a Manure Spreader



If you'll send a postal for my Special 1911 Spreader Offer, I believe we can make a deal. If we do, you'll save at least \$25.00, perhaps \$40.00, according to size and style you want. And you get a free trial and a guarantee that would break me if my Spreader wasn't right. I know I have to go high on quality and low on price, because I sell by mail. The other fellow is right on the ground to persuade you personally. My quality and price has to do all my persuading. Let me try it. Our capacity is 42,000 spreaders this year in order to quote the low prices I do—30 to 365 days free trial and my long time binding guarantee in writing.

\$25.00 to \$40.00 saved—think of it! That's fair, isn't it? If you can think of a fairer proposition than I'll make you, I'll print it in my next advertisement.

Get your pencil or pen right now, and send me a postal for my big Spreader Book, showing 5 styles and sizes, from \$39.50 up. I'll send the book free and a proposition that will make you do some tall thinking whether you buy from me or not.

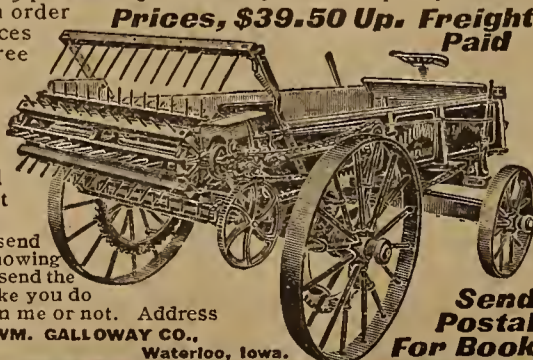

Send Postal For Book

## Half a Million Acres Open to Settlement

Three Thousand Government Homesteads



Direct Route to Gregory, Dallas and Rapid City South Dakota

Which are points of registration for opening of the

Pine Ridge and Rosebud Indian Reservations

Time of Registration October 2 to 21, 1911

For printed matter and full particulars apply to

Chicago and North Western Railway

A. C. Johnson  
Passenger Traffic Manager  
Chicago, Ill.

## Free Roof Insurance Against Lightning

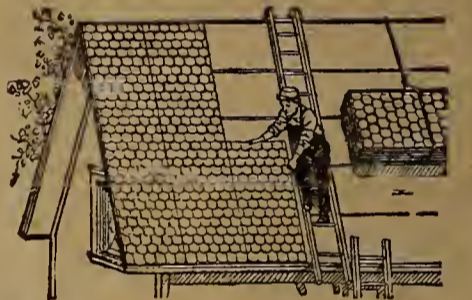

## Edwards Interlocking "Reo" Steel Shingles

Write today for our Big Free Catalog No. 658, which gives full details about Edwards Interlocking "Reo" Steel Shingles and other metal roofing and materials made by us. It tells you all about the Ten Thousand Dollar Guaranty Bond, which insures every Edwards "Reo" Steel Shingle Roof against destruction by lightning for all time. Edwards "Reo" Steel Shingles are made of high-grade Bessemer Steel in sheets 5 to 12 feet long and 24 inches wide. Either painted or galvanized steel and all ready to put on. You can easily put them on yourself. Only hammer and nails required. We have a Special Cash Money-Making Proposition for the man who writes for it, in each community. If any of your buildings need roofing, you are the man. Send dimensions of your buildings and we will quote you cost of an Edwards Roof—freight prepaid. Write for offer—NOW.

The Edwards Mfg. Co., 988-958 Lock St., Cincinnati, O.  
Largest Manufacturers of Steel Roofing Material in the World (50)

It is to your advantage to mention Farm and Fireside in writing to advertisers. Farm and Fireside folks get the very best results.



## White Lead on the Farm

Fences—Neat, well painted fences around your buildings will add dollars to the value of your farm.

## "Dutch Boy Painter" Pure White Lead

mixed "on the job" with pure linseed oil and applied to your fences will pay for itself many times over by preventing decay, saving repairs and early rebuilding.

### Our Free Painting Helps

We will send you free on request color schemes and miscellaneous painting instructions that you will find of real, practical value. Ask for Helps 1447.

NATIONAL LEAD COMPANY  
New York Cleveland Chicago St. Louis  
Boston Buffalo Cincinnati San Francisco  
(John T. Lewis & Sons, Co., Philadelphia)  
(National Lead and Oil Co., Pittsburgh)



## Garden and Orchard

### The Paper Mulch

IN REPLY to a subscriber of Superior, Wisconsin, and others interested in the culture of strawberries and other small fruits, so far as the application of paper mulch is concerned, I will state, as far as I know, it is an entirely new feature. We have tried it out but two seasons. While only in its infancy, it has given great promise, having few if any faults, and being superior in many ways to any other mulch or covering. There are many localities in this country, too, where berries thrive wonderfully, but it is a hard matter to procure straw or other suitable material in these places to cover them. The paper mulch, being light, clean and compact, can be shipped readily at very low freight rates. I believe it is classed as fifth rate. It is easily and quickly applied to the newly set row after the plants have been set. It consists of two pieces of paper (Fig. 1), with holes at proper places and fitted together as shown at 4, Fig. 1. These papers are held to the ground by pins (D, Fig. 2).

The holes or openings (2, Fig. 1) have been tried out at varying distances apart and of various sizes across, but from the short

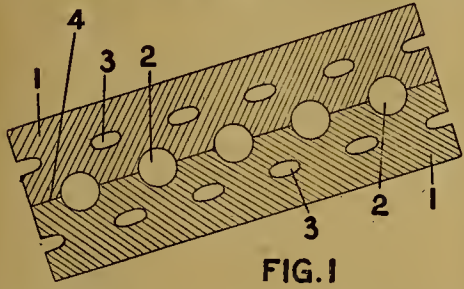

FIG. 1

experience at command an opening approximately two and one-half inches in diameter of a circular shape seems to be about the right standard demanded by the growing plants (B, Fig. 2). An opening of this size, especially in large growing plants or varieties, allows ample room for large crowns and growth; openings made too small tend to dwarf the plants. One must understand that these openings also act as air vents, but from my experience I would say that plants make a larger growth when mulched with paper than the same varieties of plants on similar soil mulched with straw or other material. This leads me to believe that they obtain the greater portion of their air through these openings directly above the roots, and so stimulate a greater energy on the part of the plants to grow than otherwise. The subsequent size of the berries on such plants is usually correspondingly large.

The openings (3, Fig. 1) have been tried at all distances apart for runner plants (A, Fig. 2), but from two to three inches seem to be about right. These are arranged in two to three rows the length of the strip of paper on each side of the original mother plants or row of openings down the center of the sheet. I divide the sheet in halves, and crowd each

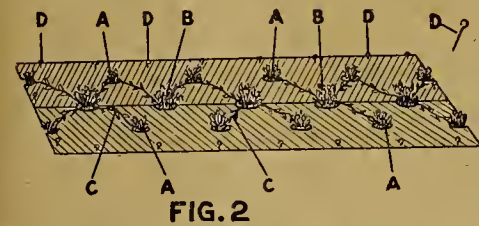

FIG. 2

strip from opposite sides snugly up to the original row. It is easier, quicker and better accomplished in this way than by placing down a whole sheet and then more or less bruising the plants by fingering them through the openings. Besides, one may remove the mulch before the runners set, to fertilize the plants, etc., if the divided sheet is used. I have never had a single plant winter-killed under the paper mulch. No cheaper or better frost retainer or repeller is known than paper, plants thaw very gradually when covered with it, and never heave.

As to the kind or variety of paper I employ as mulch, I am still experimenting. The darker papers (sheathing, etc.) seem to be tougher and more impervious to water than the lighter kinds, but with the disadvantage of color (for black readily absorbs heat). Many winter days are of cloudless sunshine, and I have had the foliage scald on plants quite badly. A light paper—that is, light in color and of a tough, pliable nature—should be used. I believe a paper specially devised would eventually be made were this mulch to gain the popularity of berry-growers, as its trial under my conditions so far warrants.

There are many entirely new features and surprises this method gave me and I expect others will crop out from time to time. To be brief, here is one instance: During the trials, a sheet having only the original openings for the mother plants, wherein they were duly set, was used, and only four plants from runners allowed to grow from each. As these could not root through the solid paper, their rootlets finally dried and rounded

bulbs came in place, the roots falling off. These runner plants with few exceptions grew and the next season surprised me by blossoming full and having nearly a full crop of fine berries, the stems connecting with the mother plants grew much larger than the ordinary ones, and were very strong and green throughout the season.

Of course, the rows of plants may be spaced to suit individual growers, all the way from three to six feet between rows, and the plants in the row may also be spaced six, eight, twelve or eighteen inches as desired, making the openings to correspond. This mulch could be perforated by special machinery rapidly and cheaply.

I had had luck with this year's setting and lost many plants, mostly by crown-borers, but expect to set plants by this system again next season, as I have every reason to believe this is a great plant mulch and especially good for strawberries.

The mulch holds moisture in an ideal manner, is an absolute protector from weeds, grass, etc., and plants thrive better than when mulched in the ordinary way with straw, etc. At berry-time the fruit is always clean.

G. A. RANDALL.

### Hidden Treasures

YEARS ago we used to grow the big field pumpkins for cow-feed in the corn-fields. They were thickly strewn over the ground, hidden under thickest foliage. Those were the bugless, happy days. Often a number of large specimens grew on one vine, or even on one branch. We gathered wagon-load after wagon-load, and the results showed in the milk-pail.

Now I regularly grow the "Pie" or "Sweet Potato" pumpkin in the sweet-corn patches, or sometimes alone in some odd corner of the garden. The flesh of this type of pumpkin is of finer and firmer texture, lacking the coarseness of the ordinary field pumpkin, and the specimens are smaller, usually of quite uniform, medium size. When planted in a rich garden-spot, the ground seems to be "almost covered" with the golden fruit, and this hidden under a rank growth of leaves, and there is a good demand for it for pie-timber. I retail a good many at about ten cents apiece, or sell them by the quantity to grocers at some reduction. But the crop is always a profitable one. Besides, we've got to have a fair quantity for ourselves, as the pies—good, old-fashioned, well-made pumpkin pies—are always appreciated by old and young. My winter squashes are grown in the same fashion as the pumpkins. They also pay well.

T. GR.

# GLASTENBURY

## HEALTH UNDERWEAR FOR MEN



Made in fine Australian Lambs' Wool, Worsted and Merino

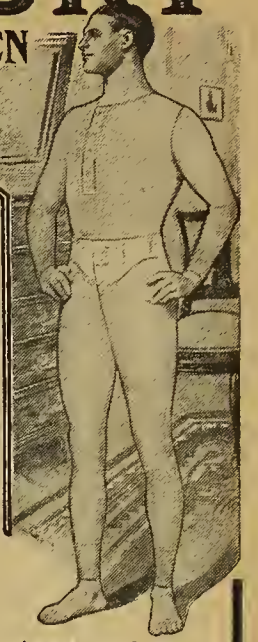

A leader for over fifty years, Glastenbury has proved its superiority as to fit, finish and wearing qualities. Guaranteed not to shrink.

Every garment shaped to the figure. Drawer bands are adjustable and require no suspender straps. No guessing as to size. Exact chest measurement on every shirt, exact waist measurement on every pair of drawers. Every garment guaranteed.

All Glastenbury underwear is elastic, non-irritating and durable. Made in five grades each, light weight, medium and heavy weight.

None Genuine Without Glastenbury Trade Mark On Garment.

Prices 60% under imported goods of same quality.

Prices, \$1.50, \$1.75, \$2.00, \$2.25, \$2.50, \$2.75 and \$3.00 per garment.

Best protection from Grippe, Pneumonia and Rheumatism.

Write for booklet and sample cuttings.

Mills at Glastenbury, Conn.



Glastenbury Knitting Company

Dept. H.

Glastenbury, Conn.

### THE LARGEST AND BEST LINE OF WELL DRILLING MACHINERY

in America. We have been making it for over 20 years. Do not buy until you see our new Illustrated Catalogue No. 15. Send for it now. It is FREE.

Austin Manufacturing Co., Chicago

### WELL DRILLING Machines

Over 70 sizes and styles, for drilling either deep or shallow wells in any kind of soil or rock. Mounted on wheels or on sills. With engines or horse powers. Strong, simple and durable. Any mechanic can operate them easily. Send for catalog.

WILLIAMS BROS., Ithaca, N. Y.

### LIGHTNING HAY PRESSES

Tested for over 25 years. Made in many styles, Horse Power, Belt Power and Self-feed Attachment. Simple and Durable with Greatest Capacity. They make a Profitable Investment. We can suit you. Write for Catalog and Prices.

KANSAS CITY HAY PRESS CO. 124 Mill St., Kansas City, Mo.

# What Will You Sell Your Farm For?

If You Can Get \$20.00 per Acre or More, You'd Better Take it and—

# Come to Canada

To LAST MOUNTAIN VALLEY—Saskatchewan the Golden

"The Land that Pays for Itself in a Single Season"—Prof. Thomas Shaw.

Where one acre will make more real money for you than two acres in your state, and you can buy five or maybe ten acres for the price of one of your present acres. Think this over. Send for facts to prove it.

Farm life in Western Canada is just like farming in your own country. It's an American settled community with good schools, good roads, good government, good neighbors, good towns, good markets and good money. Everything is just as interesting, just as homelike, just as natural as on your present farm. BUT—crop failures and drouths are unknown. You won't have to work so hard for a dollar. You can always raise 25 bushels of wheat per acre and often 40, and get more money for it.

If your farm could be depended upon to produce, year in and year out, the average yield of Last Mountain Valley, you wouldn't sell that farm for \$300 per acre. Yet you can buy this kind of money-making land from us at \$20.00 to \$25.00 per acre. And now is the time to do it. Reciprocity with Canada is settled, and the

natural influx of Americans, which is sure to follow will create an immediate and unusual increase in Land Values.

### Valuable Books Free THE STORY OF CANADA'S WEALTH.

It will cost you nothing to get our complete library of Canada land literature and read what your American neighbors are doing. If you are not making at least 50% on your investment where you are, you ought to get these books and figure out for yourself how many acres of Canada land you could buy for the price of one acre of your present land. By sending the coupon below you can get these books together with official reports and our price list and description of over 200,000 acres of our own lands.

### Wm. Pearson Co., Ltd. Winnipeg, Manitoba

Address all Correspondence to U. S. Office 709 Temple Court, Minneapolis, Minn.

Wm. Pearson Company, Ltd. 709 Temple Court, Minneapolis, Minn.

Please send me your complete library of information on Canada lands, your price list of bargains and information about your excursion dates and rates.

Name .....  
Post Office ..... State.....  
County .....



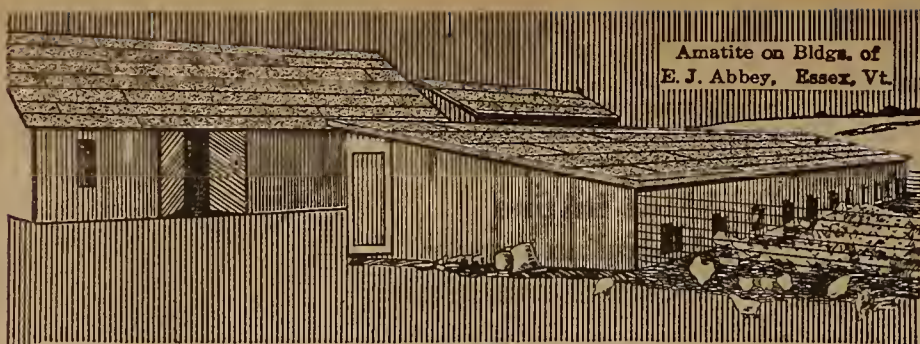

# Amatite ROOFING

Needs No Painting

AMATITE roofing is weaned. It doesn't need to be watched over and fussed with and cared for.

It takes care of itself from the start. As soon as it is laid on your roof, you can go away and forget about it.

You don't have to paint Amatite every two years as you do the "rubber" kinds. Amatite has a mineral surface which needs no painting.

The mineral surface is better and more durable than many coats of paint.

Back of the mineral surface is a layer of pitch, the greatest waterproofing compound known. Back of the pitch is a layer of felt (a whole ready roofing in itself), and behind this is another layer of pitch

and another layer of felt. The result is a strong, durable roof which can take care of itself in any climate without painting.

We will be glad to send you free a sample of Amatite Roofing so that you can see for yourself just what it looks like. Address our nearest office.

### Everjet Elastic Paint

Low in price. Great in durability. Invaluable for prolonging the life of ready roofings, fences, iron work, etc.

### Creonoid Lice Destroyer and Cow Spray

It will keep flies away from the cows. It will keep lice and nits away from the poultry, make everything sanitary and increase their output.

Barrett Manufacturing Co.  
New York Chicago Philadelphia  
Boston St. Louis Cleveland  
Pittsburg Cincinnati Kansas City  
Minneapolis New Orleans Seattle

## Headwork Shop

A Department Which Will Help You Do Your Work On the Farm

Headwork Shop continues with interest to all of the FARM AND FIRESIDE family. Many new kinks and turns are sent in each week—it is difficult to select which ones to publish. However, as our readers send in their votes, we learn the sort of kinks that are liked, and which are being used. In the following issue we publish such ideas as the votes indicate will be appreciated. So send in your vote on the Headwork Shop. Won't you? You help in placing the best idea first. The contributors of the three best kinks each get five dollars.

Why not send in some idea that has proven profitable with you? EDITOR.

firmly in the ground a little closer together than the length and width of the rack. Be sure that they are high enough for the "bare" wagon to pass under. Bolt a two-by-six edgeway on each side of the four posts as shown. Then bolt two more two-by-sixes at each end in the slanting position.

To unload rack, drive up to "stand" and fasten chain to end of rack and also to end



of chain. Drive in "stand" and rack slides up on the slanting pieces to the required place.

To load, back wagon up under rack and fasten chain as before. Start the horses and rack slides down slanting two-by-sixes and is loaded. This saves many a hard lift.

WM. BOND.

### Out Come the Grubs

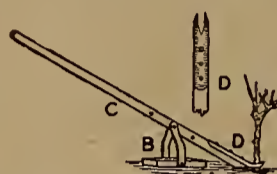

THIS device saves much labor and does the work speedily. The base (A) is made from two-inch lumber ten inches wide and eighteen inches

long. Or one can use a concrete base same size. To this base are attached two pivot arms (B) inclined inward so that the upper ends are about four inches apart. Through these arms runs a strong pivot bolt to resist great pressure. The lifting lever (C) is about eight feet long and is made from hickory or oak wood. The lifting end is made heavy, but the power end can be dressed down. On the lifting end of this lever is attached an iron plate (D) with a V-shaped cut and slightly turned upward like the jaws of a claw-hammer. The V-shaped cut is beveled and kept sharp on the lower edges so that, in lifting, these edges enter the body of the sapling when pressure is given and this prevents the lever from slipping. The lifting end of the lever can be adjusted to be eight or ten or twelve inches from the sapling by having three holes through the lever. The pivot arms should be drawn tight against the lever to prevent any play.

Properly made, this device is a great relief from the old method of grubbing out thickets. Even a grub one and one-half inches in diameter can be lifted so as to expose its leading roots. Lesser ones can be lifted clear out.

J. H. HAYNES.

### To Remove the Hay-Rack



FOR years I have used this device for lifting off hay-rack and as a rest for same and consider it invaluable

on a farm where any device to save heavy straining and lifting should be utilized. It is merely two inclined planes made to two smooth poles (AA) fastened to the four posts (BBBB), which are set firmly in the ground at an angle to brace them well both in taking off the hay-rack and putting it on the wagon. The distance between the poles is ten inches more than the width of the wagon from hub to hub. In driving between planes as indicated by arrow, the front crosspiece will strike at a point near the two short posts and by the time the team progresses to the longer posts the hind crosspiece will have removed itself from the hind hounds of the wagon without any effort on the part of the driver. I have not only removed the rack in this way, but I have had a small load of hay with myself on top taken off without any trouble. The poles (AA) should be about eight feet longer than the hay-rack.

HOWARD WALTON.

Alone it is almost impossible to put a hay-rack on and off the wagon. Here is how I save the hard lifts. Set four good posts

### Cheap, But Good



HAVE a blacksmith bend at right angles an old cultivator shovel, at dotted line, then drill two five-sixteenths-inch holes in one end, and one five-sixteenths-inch hole at the point. Then bolt to

the wagon-box at point of contact and you will have a rub-iron that will outlast a new wagon and not a bit harder on the tire than the common kind.

W. FRANK ROGGE.

### Scalding-Trough

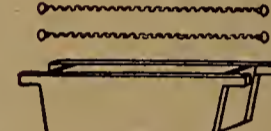

HERE is something that does away with the old barrel for scalding hogs, and is far superior. No platform is used. After the hog

is killed and pulled alongside of the trough, which is turned on the side, with the two six-foot-long chains thrown over it. When the hog is rolled in, the trough is turned back. The chains are then in position, one back of the front legs and the other in front of the hind legs. Smear a little pine-tar along the hog's back; this is an aid in removing the hair and many prefer it to wood-ashes. Then pour a wash-tubful of boiling water over him. The hog is turned by two men, each grasping the handholds of their chains and pulling with one hand while releasing with the other. The hog is cleaned while in the trough. When scraped clean, he is rolled out on an old door. The balance of the hairs are shaved off and the hog then hung.

J. E. ELLIOTT.

### Prevents Breakdowns

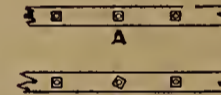

HOW much time and money has been spent already on account of loose nuts and bolts on machinery which cause breakdowns or some

other disaster. A good way to overcome much of this trouble is to leave all nuts square with the machine, then when a bolt or nut gets loose, it may easily be noticed.

HERMAN SCHIRMER.

### Muzzle for Horses

A MUZZLE to prevent horses from eating the corn while cultivating it may be easily made by sawing a circle from a piece of light board, just large enough to fit under the horse's mouth, and tacking around it a piece of one-half-inch square-mesh galvanized wire. Cut out a place for the lines. Several modifications of this muzzle are possible, but I have found this form to work best.

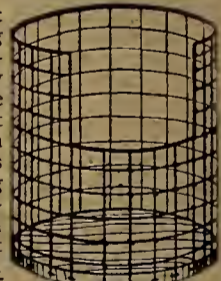

but I have found this form to work best. GEO. P. TAYLOR.

### A Good Drill

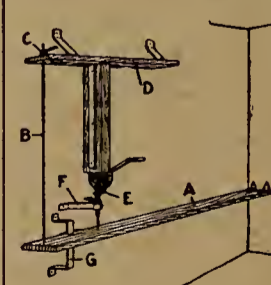

HERE is a force drill which I made several years ago and which I find almost indispensable. It consists of two shelves (A and D), the upper one stationary and the lower one hinged at the right end to the side of the shop, preferably in the corner for convenience. The other end is suspended to the upper shelf by means of the rod B, on top of which is a handle nut (C). By turning this nut an almost unlimited pressure can be brought to bear on the drill-point. The casting (E) I found in the junk-yard. The larger cog-wheel is about twice the size of the smaller, thus giving greater speed, although if such a casting could not be found one could have the blacksmith make a heavy shank having a crank like the ordinary brace. The strap-iron (F) steadies the lower part of the drill and the guide (G) obviates any vibrating motion of the shelf.

C. A. VEBURG.

### A Salary Offer To Our Readers

SCATTERED far and near are scores of snug bank accounts deposited in the names of readers who have earned the money for themselves by devoting part of their time to the interests of our publications. Many of our readers first started out to supply themselves with a little spending money and are now making a comfortable living through the liberal salaries and commissions paid to them in return for their efforts.

Right now there is a splendid opportunity on our Subscription Staff for a few more bright young men and women who are prepared to devote either their spare moments or entire time to a profitable occupation in their own towns. If you desire to join the ranks of scores of successful Staff members who are making big money in this business, send a postal card today for particulars. Address

Chief of Subscription Staff

The Crowell Publishing Company  
Springfield, Ohio

FOR INFORMATION AS TO LANDS IN

**The Nation's Garden Spot—**  
THAT GREAT FRUIT AND TRUCK GROWING SECTION—  
along the  
**Atlantic Coast Line RAILROAD**  
in Virginia, North and South Carolina, Georgia, Alabama and Florida, write to  
WILBUR MCCOY, E. N. CLARK,  
A. & I. Agt. for Florida, A. & I. Agt. for Virginia  
Alabama, Georgia, and the Carolinas,  
Jacksonville, Fla. Wilmington, N. C.

**WANTED—MEN**  
BRAKEMEN, FIREMEN, ELECTRIC MOTORMEN, CONDUCTORS, TRAIN PORTERS  
Hundreds put to work. \$65 to \$150 per month. 500 more wanted. Experience unnecessary. Application blank and map of new lines free. Give age and position wanted. Enclose stamp.  
I. Railway C. I., No. 36 Indianapolis, Ind.

**MAKE HENS LAY**  
more eggs; larger, more vigorous chicks; heavier fowls; by feeding cut bone.  
**MANN'S LATEST MODEL BONE CUTTER**  
cuts fast, easy, fine; never clogs.  
10 Days' Free Trial. No money in advance. Book free.  
F. W. MANN CO., Box 32 MILFORD, MASS.

## Come to Montana!

The great Treasure State invites you, with her 93 million acres: lots of room, lots of sunshine, lots of opportunity.

Montana is in the center of the Great Northwest Prosperity Belt. Where dry-farming methods are opening the eyes of the world to their safe and sure scientific principles and wonderful results. Where irrigation is showing what marvelous resources have lain under the cattle range.

Free Government Homestead Land in choice localities. Farming and orchard land in fertile valleys at low prices. You can make money and enjoy life working out-of-doors on an orchard or farm of your own in Montana. Look it over this Fall. See the harvests in the productive Yellowstone, Clark's Fork, Shields, Gallatin and Bitter Root Valleys. Low-rate Homeseekers' Tickets to points in Montana sold every Tuesday in September and October. Round-trip, 25 days return limit, with stopovers.

Send for illustrated booklets about Montana and full information about low fares.

**L. J. BRICKER**  
General Immigration Agent  
31 Northern Pacific Bldg.  
ST. PAUL, MINN.

The Northern Pacific Railway has land for sale, adjacent to its lines in Montana. For printed price lists and descriptions, address Thos. Cooper, Land Com'r., St. Paul.

### Handy Mail-Box

THE parts of outfit are as follows: A, drum used to wind box with post F. B, United States mail-box, with framework for running on wire. C, iron weight, tied to pulley J, which runs on wire O from post L to post

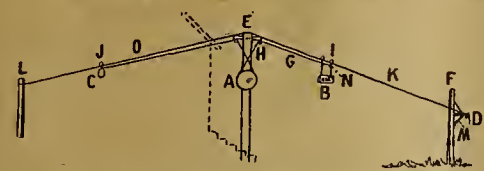

E. The weight must be heavy enough to pull box from D to H on wire K. D, hook, which catches and holds box until tripped by mail-carrier. E, post three by four inches; F, post; G, heavy cord; H, I, J, pulleys; K, wire, number nine; L, post; M, brace; N, staple to catch in hook D; O, wire, number nine.

Fasten cord G to box, then hook box at D, then run cord through pulley H, fasten to one side of drum A and wind the box to point H. Then take a cord the same length as cord G and fasten to C and to drum A. Have points D and L lower than point E, so by turning the drum A it will run box to D and will hook. That brings C close to pole E, so that when the hook is tripped at D, C will run down O and will draw box in to H. VIRGIL COX.

### A Handy Wire-Splicer

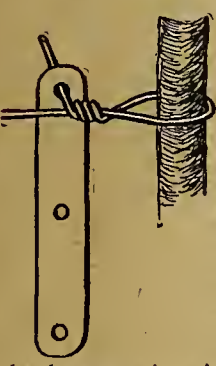

WHEN building woven-wire fence, or doing any work where a number of splices must be made in wire, a need is often felt for a splicer which will get in between the wires and do better work than the splicers usually found on combination tools. To make such an instrument, it requires nothing more than a piece of stout strap-iron, six inches long and an inch wide. A hole larger than the largest wires is bored in each end and in the middle. The illustration shows its use; the wire to be twisted is slipped through one of the holes and then twisted about the other by means of the splicer, making a compact and strong splice. Where the wires are farther apart, the end holes may be used, but when close, as at the bottom wires, the center hole is handier. ADEN J. RUNKLE.

### Extension Ladder

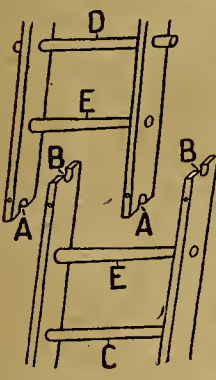

THIS is the way I made some extension ladders, which are simple and safe and can be put together or taken apart very quickly. The side pieces are one-by-fours, twelve feet long, put together in the usual way, except at the ends where they join. Use an inch bit and bore holes in center about two inches from ends and saw out at A and B. A fits on inner side on rung C and B slips into rung D, which projects two

inches. E E are loose rungs made to slip in and are larger at one end so they can be driven tight and will not go through. Bolt the ends to keep from splitting. When you joint them, knock out the loose rungs and slip ladder together, replace one of the rungs and drive tight. The ladder is now ready. CHAS. A. LEATHERS.

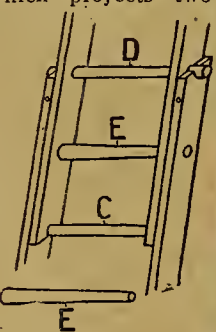

### Let One Man Saw

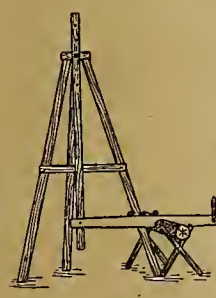

THIS machine which makes sawing wood possible for one man is easily made. Three poles or other rods form the frame on which the saw swings. Another rod fastened to a bolt at top of frame plays inside two boards. The saw is made fast to the lower end of this rod, so it will swing back and forth as shown in the cut. To hold the wood, you can either have a horse or drive stakes into the ground, having them crossed at top. The supports are nine feet long for the sides and ten feet for the other. The pendulum on which the saw is fastened is eight feet long and has holes bored so it can be easily raised or lowered. The stakes on which the logs are placed are from two to six inches in diameter.

A person can saw a cord of wood in two hours with this machine. J. B. WATSON.

### A Handy Wire-Grip



A SERVICE-ABLE barbed-wire grip can be made out of the hook of an old singletree. The part that fastens the hook to the singletree should be cut off. Next heat the hook, then put an old file, or any piece of iron the same thickness as the wire, in the hook as shown in Fig. 1. Fasten the hook, and the grip is finished. This grip is easily made and is just the thing to stretch wire with the block and tackle. Fig. 2 shows the grip. W. R. JOHNSTON.

### Home-Made Corn-Popper

HERE is a home-made corn-popper that beats the "bought ones." Take a piece of heavy wire about three-sixteenths inch in diameter and about seven feet long. Double and twist the wire from the middle to within nine or ten inches of the end, then spread and bend like A. Take a half-gallon syrup-pail, punch holes in center of the ends to receive wire and perforate the pail with small holes. Bend ends of wire so that they are plenty long, and must be sprung a little to be put on. Spring your handle on and your popper is complete. In use simply roll on the stove and it works fine and does not burn the corn. E. S. CALDWELL.



### Holds the Bag

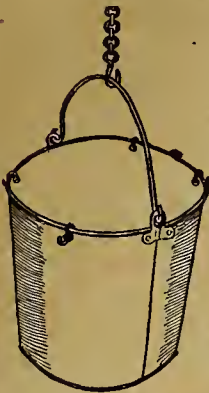

THE sketch shows a handy filler and bag-holder. From an old fourteen or sixteen quart galvanized water-pail the bottom is taken. Three or four wire hooks are put around the top rim to catch in the sack, the pail is then hung by a short chain so that the bottom of the sack rests on the floor while filling. One advantage which this device has over many is the small space required for its storage. It may often be hung on the walls out of the way of anyone desiring the space for other work. Or, if a rope is used instead of the chain, the filler may be drawn up out of the way if a small pulley is properly arranged. E. S. CALDWELL.

### Incubator Greenhouse

WHEN I had a new pit for flowers dug last fall, I had a place just a little larger than my incubator left, about a foot higher than the rest of the floor; it is where the draft will not blow on it, either from door or windows, which are glass and hinged at top. By putting shelves near the glass, I can raise all the early plants I need for my garden, the incubator making it quite warm enough, a success in every way. TILEA E. HUFF.

### Winners—August 10, 1911

FARM AND FIRESIDE readers are asked to send in post-card votes, telling which three ideas in each issue they think are best. The ideas receiving the highest number of votes in the August 10th number were:  
Solid Sod Hog-House - F. L. Booth  
To Save Trimming Lawns - H. L. Cloz  
Carriage Whip-Holder - Ruben Fulmer

You Get a New Suit or Overcoat in Exchange, If For Any Reason You Are Not Satisfied With the



Costs Only \$15.00

Worth at Least \$20.00

"AMERICAN STANDARD 15" Suits and Overcoats for men and young men are cheap in price only. The all-wool fabrics, the hand-tailoring, the style, the fit, the wearing qualities are every bit the equal of other brands that sell for at least five dollars more.

Prove this for yourself. Go into any "AMERICAN STANDARD 15" store. See the garments, examine them critically, try them on!

"The AMERICAN STANDARD 15" and other American Clothes values are made in Baltimore—"The City of Economy"—in a big, modern tailoring establishment.

The high-class tailoring put into them costs us less, because living expenses are less in Baltimore than in any other clothing center. That is the reason why we can produce such remarkable values for so little money. You are given the benefit of this economy.

If there is no "AMERICAN STANDARD 15" dealer in your town, send us your name and address, and we will mail you style book and order blank, and see that your wants are filled.

AMERICAN CLOTHING MFG. COMPANY

Dept. 3 Baltimore, Md.



## Why Buy a Second-Hand Car— This, Brand New, is Only \$1600

THREE years ago there was good reason for preferring a second-hand car of high priced make to a new automobile at from \$1500 to \$2000.

CONDITIONS have changed. Such an automobile as the HUDSON "33" three years ago would have cost at least \$3500. Even then it would not have had many of the features which have made the HUDSON "33" famous, and which established a new standard in automobile construction.

FIVE years ago a car such as the HUDSON "33" would have been impossible at any price. This shows the advancement in engineering, designing and manufacture that has been made in the past few months by the engineers of the HUDSON Motor Car Company, headed by Howard E. Coffin.

SOME still recommend a second-hand automobile of high priced make, rather than a new car of moderate cost. But do you think that good advice? The HUDSON "33" is dust proof. It is handsomer, more modern, quieter, more easily operated, more cheaply operated and more comfortable, and much simpler than any automobile of any design of two years ago. All these things contribute to value. Beside, it has all new equipment. Its lines are longer and lower, and more pleasing, and if you ever want to sell it, you can get nearer its purchase cost because of its modern design, than would be possible to get for the car of two years ago that you buy at second hand or get new at a reduced price. You will realize this if you own a HUDSON "33." You will be convinced of it if you ask any owner of a HUDSON "33" as to its performance.

There is a HUDSON dealer near you who will gladly explain all about the HUDSON "33." If you don't know his address, write for color portfolio of models, details, etc.

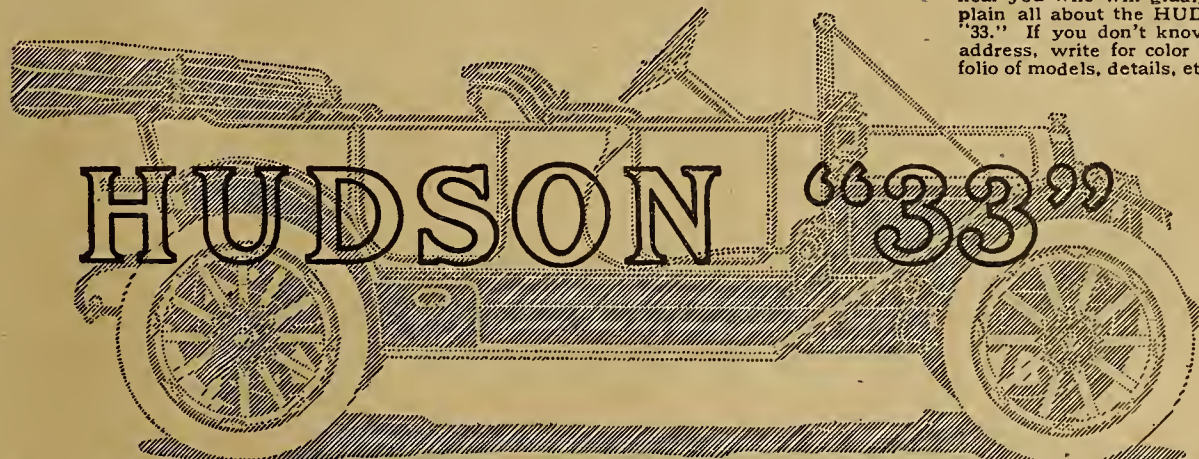

THE HUDSON "33" is furnished in four models: A Touring Car, a Torpedo, a Torpedo Roadster and the Mile-a-Minute Roadster. The price of each is \$1600 f. o. b. Detroit. All models except the last named have closed bodies, genuine mohair top and wind shield. Demountable Rims, extra rim, tire irons, 34 x 4 inch tires, highest grade black enameled lamps, Bosch magneto, Prest-O-Lite tank, tools, etc. The Mile-a-Minute car has storm apron and 100-mile-an-hour Warner Auto-meter. Both Roadsters have luggage box on rear, around which extra inflated tire can be carried.

"See the Triangle on the Radiator"

Hudson Motor Car Company

7123 Jefferson Ave., Detroit, Mich.



**Whether it is Auto or Carriage—Paint Means Wear**

The man who is in the Auto class knows the importance of keeping things "spick and span." He knows that the right paint means longer life. And hundreds of thousands of users of Acme Quality Carriage Paint (Neal's) testify to its perfect protecting and beautifying quality. It's one of the big family of

**ACME QUALITY**

**Paints and Finishes**

that provide for every surface around farm or home. Each the best for its particular purpose. Acme Quality Carriage Paint is best for anything requiring a brilliant varnish-gloss finish that will withstand extreme exposure and hard use. Rich colors and black. Write us to-day for a copy of the

**Acme Quality Painting Guide Book**

It tells just how any paint, enamel, stain or varnish should be applied and what should be used for a given purpose. Illustrated in colors—sent free. Ask your dealer for Acme Quality Paints and Finishes. If he can't supply you, write to



**ACME WHITE LEAD and COLOR WORKS**  
Dept. X, Detroit, Mich.

**Crops and Soils**

**Fall Plowing**

WILL the pressure of harvesting and thrashing, silo-filling and corn-cutting prevent you from giving that back forty the fall plowing it has been promised these many years? You know that it cannot get its share of the manure produced on the farm, therefore you have promised it fair treatment in other ways. Lack of manure and the occasional killing out of clover have left the field rather low in humus. The soil does not work up into the mellow seed-bed that it once did.

You have generally noted that early-seeded oats on fall-plowed land escape the scalding heat that late-seeded oats on spring-plowed land are bound to receive. The clay soil on the back forty must be fall plowed in order to prepare that early, mellow, yet firm seed-bed. Recall for a moment the advantages that fall plowing has over spring plowing, especially on heavy clay or clay loam soils:

- (1) Production of better tilth.
- (2) Increased water-supply.
- (3) Increased food-supply.

Heavy soils are apt to be wet in the spring, so that plowing operations may result in the utter destruction of good tilth. A single plowing of a clay soil too wet may require the persistent effort of an entire season to bring the soil back into good condition. The exposure of the furrow slice to the alternate freezing and thawing, wetting and drying of the winter months results in a rearrangement and granulation of the soil particles. Clods are wedged apart by the growth of ice crystals, and break down into smaller clusters of soil grains.

The compact sod, or stubble field, beaten down by the rains of the season, no longer permits easy entrance of water. Run-off and surface evaporation are sure to get more than their share of the fall and winter rainfall unless that soil is loosened up. F. H. King found that in May a piece of fall-plowed land contained 110 tons (over an inch) more water per acre than a similar adjoining piece not plowed. Experiments in New Hampshire showed from 72 to 264 tons more water in fall-plowed than in similar spring-plowed soil. The saving of an inch of water represents enough water to produce over three bushels of wheat, six bushels of oats, six bushels of corn or fifty bushels of potatoes per acre, provided it can be entirely used by the crop. Does it not appear to be worth while to save an inch of water?

The early stirring of the soil promotes decay of the vegetable matter and converts the nitrogen locked up in the humus material into available plant-feeding nitrates. The longer aeration and weathering of the fall-plowed soil results in the production of available mineral plant-food as well. Insoluble potash minerals such as the feldspars are split apart by the action of water, and the potash dissolved out of them by the water and carbon dioxide. All mineral soil particles yield to the action of the weather to some extent, so that the crop started on the fall-plowed land next spring has a decided advantage in the early critical periods of its growth.

Realizing that not only the back forty, but other fields on the farm as well need to be kept in good tilth, and that water and food supply are always critical factors in crop production, how can we be fair to our heavier soils unless we give them the advantage of fall plowing? H. L. WALSTER.

EDITOR'S NOTE—Farmers cultivating soils naturally light and leachy will disagree, and rightly, with our Wisconsin champion of fall plowing and contend that a legume or other cover crop will accomplish more for profitable crop production than any advantage derived from fall plowing. The erosion prevented, the vegetable matter added, and the locking up of nitrates which otherwise would be lost before the spring-seeded crop can use this fertility must in turn be considered before farmers variously situated can decide the best time for plowing.

**Quack-Grass Again**

A READER in Wisconsin states that land in his vicinity has on it a great deal of mustard, Canada thistles, quack-grass and crab-grass. He pleads for help.

These weeds propagate themselves to a great extent by means of underground-running root-stalks which, when broken up, form new plants; hence ordinary plowing, harrowing and cultivation serve merely to increase the number of plants. Two special methods of eradicating these weeds are followed with more or less success. The dryness or wetness of the season is a factor that has much to do with the success or failure of killing these weeds.

One method is to devote an entire summer to plowing and harrowing the weed-infested land, without attempting to secure any crop. By this method the ground is plowed very deep so as to reach the horizontal roots three or four times during the season. Between times the harrows are kept going sufficiently



SENATOR LA FOLLETTE AND FAMILY

The Senator is standing, and Mrs. La Follette, whose great good sense and sound advice have helped him since the days when they were classmates at The University of Wisconsin, is seated in the center, by the side of Dr. Phillip Fox, a friend of the family. "Bobby," Jr., is standing, and "Phil," his brother, is in front of Dr. Fox. Mary is at her mother's feet.

**An Interesting Start in Life**

UNITED STATES Senator La Follette of Wisconsin writes the first chapter of his autobiography in the October number of **THE AMERICAN MAGAZINE**, which is published by the publishers of **FARM AND FIRESIDE**.

You see him in this first chapter as a farmer's boy, just out of The University of Wisconsin—poor, in debt, but with tremendous aspirations booming in his brain, and such "hustle" as is rarely seen. He conceived an ambition to become prosecuting attorney, and, with an old horse, started out literally to see every voter in the county! This aroused the anger of the political boss, who thought that any candidate for an office should see *him* first. This resulted in a terrible fight, but young "Bob" La Follette won. Now came four years of exciting work as prosecutor—and then a new ambition—a desire to go to Congress and again serve his people. Another fight with the everlasting boss, and La Follette, at thirty years of age, found himself in Washington, the youngest member of Congress—a man five years out of college who never had been east of Chicago.

It is all told so simply and personally, with such a fund of incident and detail, that no human being who takes it up can lay it down until the last page. La Follette himself surely cannot realize the attractiveness of his narrative to the reader. He cannot possibly realize how the reader will smile with pure delight at the tremendous enthusiasm and determination of the boy who was to become "the most conspicuous Senator of his time."

This remarkable life story will continue as a regular monthly feature of **THE AMERICAN MAGAZINE** for nearly a year.

We will send **THE AMERICAN MAGAZINE** to any **FARM AND FIRESIDE** reader for a year for \$1.50, and we will send **WOMAN'S HOME COMPANION** for a year for \$1.50. We will send both **THE AMERICAN MAGAZINE** and **WOMAN'S HOME COMPANION**, each for a whole year, for the special price of \$2.20—a saving of 80 cents. We will send you the October **AMERICAN MAGAZINE** for 15c.

**THE AMERICAN MAGAZINE**

The Crowell Publishing Company

Springfield, Ohio

(Or 381 Fourth Avenue, New York City)

Only **\$29<sup>75</sup>** and up  
SENT DIRECT FROM FACTORY TO YOU, FREIGHT PREPAID

Never before in Cream Separator history could you get a high grade Separator—with gears running in a "Bath of Oil"—the superior of any \$85 to \$110 Separator, at such a low, direct-from-factory price as I'll make you. Save \$25 to \$50 this way. I make and sell so many I can afford to make the price as low to you as dealers and jobbers have to pay in carload lots—spot cash—for other high grade Separators.

**TAKE 90 DAYS' FARM TEST OF A GALLOWAY HIGH GRADE "Bath in Oil" Separator**

Closest skimmer—Easiest running—Easiest to clean—No trouble oiling or danger of running dry like others, which alone is worth \$50 extra. Costs nothing extra on a Galloway. Send me your name today so I can write you my Special Proposition, at the price I'm making direct to farmers and dairy men, based on my output of 14,500 Galloways this year. I'll also send you my big BOOK FREE. Address—Wm. Galloway, Pres., WM. GALLOWAY CO. 743 Galloway Station, Waterloo, Iowa

**KITSELMAN FENCE**

Get It From the Factory Direct

Sold direct to you at factory prices on 30 days trial. Save the dealers profit. Farm, Hog and Poultry Fence at from **11 1/2 CENTS A ROD UP**. All wires are heavily galvanized 80 rod spool of Ideal galvanized Barbed Wire \$1.55. Write to-day for large free Catalogue showing 75 different styles and heights of fencing.

Box 272 KITSELMAN BROS. MUNCIE, IND.

to prevent any leaf growth being made. By means of a spring-tooth harrow the roots are brought to the surface and become dried out and die before the end of the season. If this method is followed persistently throughout a season, neither the quack-grass nor the Canada thistles will survive. But in case the season is not dry enough to make this work entirely successful and a few plants are left remaining alive, by means of a cultivated crop the following season, such as corn or potatoes, the few remaining plants can be entirely killed.

Another plan which I have personally employed with success is to plow the land as soon as a crop of hay has been cut in July. Then harrow repeatedly through August and September, or as long as the ground is dry, allowing no leaf growth to take place, and late in the fall plow very deep just before the heavy frosts come. The action of the frost on the lower portion of the roots will kill any of these that may yet have some life in them. In the spring, as soon as dry enough, repeat the harrowing until time for planting corn. Then by perfectly clean culture throughout the growth of the crop I have found that quack-grass, crab-grass and Canada thistles can be entirely killed.

B. F. W. T.

### Broom-Sedge Bedding

COUNTLESS fields of broom-sedge are found in this part of the country (Ohio). Many farmers burn it in the spring to get rid of it, and to secure the fairly good pasturage furnished by the tender young growth that then springs up. Many leave it to grow unmolested, when it kills out all the grass and furnishes nothing in its place. I use it for bedding, for which purpose it is nearly as good as straw. I generally put it up in the winter when there is not much other work on hand. Used in this way it absorbs the liquid manure and carries it to the land, besides making a generous addition to the supply of humus. I am told that, if cut green, stock will eat it, though, of course, it could not be expected to make very good hay. It would be a great help, however, in a scarce time. One of my neighbors sold some for five or six dollars a ton.

ROBERT BRADFIELD.

### Wheat-Straw is Useful

A FEW years ago we began raising wheat as one of the grain crops of our farm. Of necessity we had a considerable amount of wheat-straw as a by-product. We found it to be of little or no value as feed for stock. If left in a stack, it required several years for it to rot sufficiently for use as manure. Another objection to leaving it in the stack was that there was always a considerable area where the stack had stood that was made excessively rich in plant-food and could not be worked up satisfactorily with the rest of the field.

Of course, we did not wish to burn the straw, as that would be a direct waste of humus, which our soil has already begun to show need of.

One day it occurred to us that the best and quickest way of converting the excessive amount of straw into a condition to be returned to the field as manure was to run it through the barns and yards containing our live stock. Since then we have used two or three times as much bedding as we formerly did and have found it to be very satisfactory. Of course, there is a little bit of extra work connected with this method, but that is partly made up by the fact that we do not need to waste any time in sifting the manure and wet litter from the dry bedding.

Any dry bedding that we gather up will be so thoroughly mixed with the soaked portion that it will very quickly be started to decaying. This use of large amounts of straw for bedding saves all of the liquid manure just as effectively as do gutters and sewer traps. That is a fact worthy of consideration.

We have found that our stock are far more comfortable when large amounts of bedding are used. Our horses seem to rest better and are free from stall stains. The cows and calves lie more contentedly and comfortably. In steer-feeding, wheat-straw, spread around in the open yards, causes the steers to scatter and to lie down and chew their cuds. This is essential to the best growth. In muddy times, heavy applications of wheat-straw help to keep the surface of the yard solid. Wheat-straw, being very brittle when dry, breaks up into short pieces and makes very satisfactory bedding for hogs, even for brood-sows.

H. E. McCARTNEY.

### Winter-Killing of Clover

AN ILLINOIS reader asks if in our opinion there is any way in which clover may be sown in wheat in the fall so as to catch up—or anywhere near catch up—with clover sown with oats in the spring, so as to even up his fields for a rotation plan.

The trouble is that the clover is likely to be killed with the heaving of the ground in winter, when so lightly rooted as it is when sown in the fall. Seed would probably be lost instead of the fields being evened up by seeding clover in the fall.

B. F. W. T.

### Misuse of Manure

THAT the manure-spreader should have found a prominent place among "Favorite Tools" is by no means surprising, but, like all the good things of this life, it should be used with caution, for there is a real danger in a certain direction to follow on its misuse. Where labor is scarce, it is very tempting to be able to remove the manure from stables, barns and cattle-sheds directly to the field, but this economy of labor, if too closely followed, may lead to serious consequences.

In my judgment, no animal can be exposed for any length of time to the exhalations arising from its own excreta without injury. No amount of bedding, no perfection of ventilation, though in their way most desirable, will save animals from this exposure, if underneath the nice clean top layer of straw a sub-layer of rotting manure is allowed to accumulate. All the floors of buildings in which animals of any class are confined should be thoroughly cleansed at least every other day. A covered shed, handy to the buildings, should be provided for the manure, which should occasionally be thoroughly sprinkled with water to prevent what is known as fire-fang.

Another reason for pursuing this method is that manure allowed to accumulate in the stalls will be found in various stages of decomposition: the lower layers thoroughly rotted, the upper straw in almost its natural condition, and so of no value as manure.

JOHN PICKERING ROSS.

### Basket Willows for Marsh-Land

IN THE State of Ohio, and in most other states, are many acres of low, wet or swampy land of which the owners make no use. These might profitably be planted to basket willows. There seems to be a widespread difference of opinion in regard to the cost of growing the willows and the profits of the crop. Unquestionably there is no fortune in the business, but by care, and by planting a superior grade, soil which is now unproductive may be made to yield a net return of from one hundred to one hundred and fifty dollars an acre.

The expense of starting a plantation depends largely upon local conditions, but the Forest Service Bureau of the United States Department of Agriculture is always ready to send helpful information. The preparation of the land need not be particularly expensive, but the price of the cuttings may raise the initial cost as high as seventy-five dollars an acre. Desirable cuttings should not cost more than one dollar and fifty cents or two dollars per one thousand, and may sometimes be obtained for one dollar a thousand. The second year, and thereafter, the expense of cultivating, harvesting, peeling and marketing should not exceed eighty-five dollars an acre, which is, perhaps, two fifths of the total gross income. A well-managed willow plantation should average about four thousand pounds of peeled and dried rods per acre, though the quantity will vary with different soils and climatic conditions. Five cents a pound is a conservative price. This gives two hundred dollars, which leaves something over one hundred dollars for profit.

The farmer who gets rich is the man who can improve quality at the same time that he reduces the cost of production. Experience teaches that in the state of New York, where farmers grow basket willows on low, wet or swampy land and sell them green—that is, with the bark on—he does not realize a profit of more than thirty or forty dollars an acre. Old willow-growers, on the other hand, claim to be able to raise nine to twelve tons per acre, by drainage and fertilization. The United States Forest Service has succeeded in cutting over eleven tons of green rods on the experimental plat at Arlington, Virginia. Circular No. 148 gives results of several experiments.

There are two methods of marketing willows—green, or peeled and dried. The former is the easier method, but produces least returns. In order to secure the highest price, rods must be graded for height and quality, and weighed separately. The best kinds bring from twenty to forty dollars a ton. Long, slender, cylindrical and flexible rods always command a high price. Willows, like apples, are not infrequently sold by inspection, on the ground. In the fall of the year a buyer may offer from twelve to twenty dollars a ton, a system which is sometimes convenient for the grower. The price paid for green rods is for weight as delivered at the station from which they are shipped. Many growers prefer to hold their willows till spring, when they may be easily peeled. After careful grading, the bark is removed, the rods are bleached in the sun and thoroughly dried before being offered for sale. Treated in this manner, they ordinarily bring about seven cents a pound, though a superior quality of long, slender rods, suitable for the best kinds of wicker furniture, sometimes command as much as sixteen cents a pound. By making a study of the markets, and the general trend of wicker furniture, a grower may easily learn what class of rods are in demand by manufacturers of high-grade basket and furniture ware. Owners of swamp-lands in Maryland are doing well with this industry, and there is no reason why it should not be profitable in other sections.

E. YOUNG WEAD.



## Sell Your Crop by Telephone

There is a market for your product, and a price that will give you greatest profit. The surest way to find that market, and to know that price, is by telephone.

But be sure your telephone is a

# Western Electric

TRADE MARK

## Rural Telephone

—the trouble-free, clear-talking kind made by the manufacturers of the celebrated "Bell" Telephones. Farmers everywhere use Western Electric Telephones.

Mail coupon to-day for booklet telling how you can get a Western Electric Telephone.

The Western Electric Company Furnishes Equipment for Every Electrical Need.

Your name and address written in this space and mailed to our nearest house will bring complete information

Booklet No. 50

Address

EVERY BELL TELEPHONE IS A WESTERN ELECTRIC TELEPHONE

WESTERN ELECTRIC COMPANY

Manufacturers of the 6,000,000 "Bell" Telephones

New York	Chicago	Saint Louis	San Francisco
Buffalo	Indianapolis	Kansas City	Oakland
Philadelphia	Cincinnati	Denver	Los Angeles
Boston	Minneapolis	Dallas	Seattle
Pittsburg	St. Paul	Omaha	Salt Lake City
Atlanta	Milwaukee	Oklahoma City	Portland
Montreal	Toronto	Winnipeg	Vancouver
London	Paris	Antwerp	Berlin
Johannesburg	Sydney	Tokyo	

SAVE TIME AND FREIGHT

TELEPHONE OUR NEAREST HOUSE

# WINCHESTER



## REPEATING SHOTGUNS

If you want a serviceable shotgun, one that a scratch or bump won't ruin, that can be had at a price that won't ruin you, the Winchester Repeating Shotgun will surely suit you. They are made in 12 or 16 gauge with strong shooting, full choke barrels, suitable for trap work, duck shooting, etc., or with modified choke or cylinder bore barrels for field shooting. They list at \$27.00, but your dealer will sell you one for less. They are a bargain in a gun, but not a bargain counter gun. They are the only repeater that is

ENDORSED BY THE U. S. ORDNANCE BOARD



## FARM FENCE

11 1/2 cts. a rod

26 in. high hog fences; 28c for 50-inch heavy poultry fence.

Sold direct to the farmer on 30 DAYS FREE TRIAL.

Special barb wire, 80-rod spool, \$1.55. Catalogue free.

INTERLOCKING FENCE CO.  
BOX 21 MORTON, ILLINOIS.

### Cheap as Wood.

We manufacture Lawn and Farm Fence. Sell direct shipping to users only at manufacturers' prices. No agents. Our catalogue is free. Write for it today.

UP-TO-DATE MFG. CO., 971 10th St., Terre Haute, Ind.

## GET A FARM HOME NOW

We have farms for all, both great and small. In 21 States: from New York to North Dakota; from Michigan to Missouri. For free list of fine farms ask B. F. McBurney & Co., 703 Fisher Building, Chicago, Illinois.

## Income Guaranteed

Liberal commissions; big cash prizes; a guaranteed monthly salary. Such are some of the inducements for you to handle the biggest money-making offer ever made by a farm journal. A fine opportunity for energetic young men and women. Experience not necessary. You must act at once.

Department of Agents  
FARM AND FIRESIDE SPRINGFIELD, OHIO

# "EVERYBODY"

## Can Afford a Gasoline Engine With Galloway's New Low Prices

You've never before heard of such startling values—I've never offered anything like them and you know full well that no one else has ever come anywhere near my regular prices. But this time I've a startling reason—I want 10 men in every township in the county to own and operate a Galloway Engine—I've decided to double my factory capacity by increasing the sales twice and sell two where I formerly sold one—this calls for unusual values—hence, the greatest offer I have ever made. I can save you from \$25 to \$300 on an engine according to the H. P. needed. It doesn't matter what sized engine you want I've got the one to fit your wants and do more work and better work at less actual cost than any other engine in the world. Write at once for full information of the Greatest Offer Ever Made To American Farmers—don't delay but send me your name and address now, before you do another thing. Let me prove to you in cold facts why I can put \$25 to \$300 in your pocket.

WM. GALLOWAY COMPANY  
Wm. Galloway, Pres.  
745 Galloway Sta., Waterloo, Ia.

**30 Days FREE Trial**

Pump Jack \$3.95

No Such Quality in any engine—no matter what price you pay—the Galloway price saves you \$25 to \$300

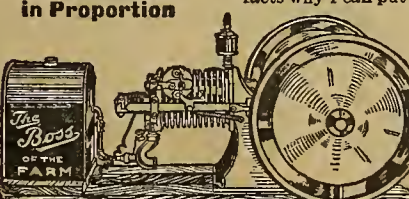

Other Prices in Proportion

1 1/2 HP \$27.50

## Farm Notes

### A Solution of the Help Problem

ONE of the best methods of getting faithful service out of hired help on the farm is to give them a business interest—"the profit-sharing plan" it is called in big industrial plants. I have tried it on the farm and it works.

The principal difficulty with farm help seems to be in getting the men interested in the work beyond their wages. This lack of interest or enthusiasm, I believe, is largely responsible for poor service on the part of the hired men, and anything that will cause a greater interest in the work will also influence them to give better service.

The cooperative plan is the only practical way to accomplish this. By talking it over with the men and doing a little figuring, one can soon decide upon the regular monthly pay and to this a percentage of the farm's income may be added, calculating so that the wages and percentage will equal the average pay in the community.

When I hired on this plan, the man asked twenty-five dollars a month the year around, house, fuel, garden and certain other privileges, which is about the customary pay of a first-class man in this part of Pennsylvania. Now, instead of his own offer, I proposed to give him twenty dollars a month cash wages and an increase over that of two and one-half per cent. of the receipts from the farm, together with the privileges he had asked for. I talked the farm work over with him—number of cows to be milked and what we reasonably might expect from that source, acreage of different crops to be planted and an estimated income from these under average conditions. He readily accepted the offer in preference to his own.

If it is a favorable year and the returns greatly exceed the average, one may have to pay several dollars a month more than would be necessary under the ordinary method of hiring; if it happens to be a poor year, wages may be less than one otherwise would have to pay. In other words, the cost of hired help with the cooperative plan is in proportion to the profits from the farm.

When a man's pay is partially dependent upon what he does, he will work with the idea of accomplishing maximum results, while if he gets a fixed amount regardless of the farm's income, the success or failure of the work is more or less a matter of indifference to him. Under the cooperative plan they realize and appreciate that the progress of the work stands for several added dollars to the regular pay each month.

In figuring the percentage increase to be allowed, one should take into consideration the regular wages, privileges and average proceeds from the farm. In my case I figured that I could easily count upon gross proceeds of \$2,400 under average conditions. To give the equivalent of \$25 a month required a regular salary of \$20 a month and two and one-half per cent. of the \$2,400 income. If the gross proceeds amounted to \$3,000 the wages would be \$26.25 a month, while if it was only \$1,800 the pay would have been \$23.75. Every \$480 increase in proceeds would increase the salary one dollar a month.

If lower cash wages were paid, the per cent. should be increased in proportion. Thus, if fifteen dollars regular salary was to be paid, the increase should be five per cent. to equal the desired wages. I believe it is best to have a rather low regular salary and a higher rate of increase than I allowed.

Another step that will help to increase the interest of hired men is to offer a higher rate of increase after the returns amount to a stated sum. For example, suppose the salary to be twenty dollars, increase two and one-half per cent., figuring on a \$2,400 income, which would give a twenty-five-dollars-a-month salary. After this \$2,400 income has been received, allow a higher per cent. of increase, perhaps double, or enough to make it an object for the help to work for. The extra income would be largely profit and one can well afford to pay the man this premium.

LYNFORD J. HAYNES.

### Blasting Out Stumps

THE reason, most probably, that powder has not been more extensively used for the clearing of land is that the would-be user is unfamiliar with its use. The actual economy of stumping powder must depend upon a number of widely varying conditions; namely, the cost of labor, the size and nature of the stumps, the nature of the soil and the cost of the powder. Experiments show that a slow-acting powder works at a higher efficiency than the high explosive kind for blasting of stumps. Any explosive, either in cartridge or powder form, having a strength of thirty per cent. to forty per cent. is most profitably used.

No set of rules can be laid down for the proper placing of the charge or the amount to be used for a given stump. I have seen a cedar stump four feet in diameter blown from its bed with one pound of high explosive powder and other cases where smaller stumps have required many times the same amount to produce the same effect.

General rules that may be followed are that the charge be placed directly under the center of the stump and always at a sufficient depth to allow the powder to spread and pull the roots rather than break them

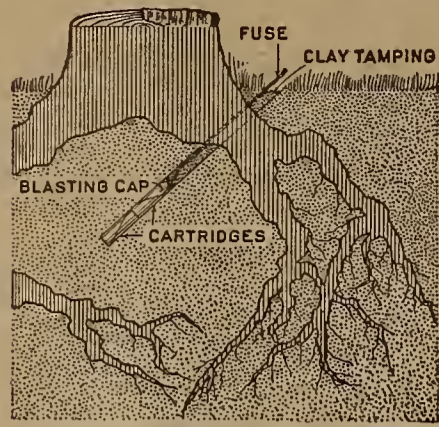

How the Powder is Applied

off. A little more powder than seems necessary will prove to be the most economical method.

Often a strong chain is wrapped around the top of a stump that is to be blasted. This prevents the stump from splitting and allows the force of the powder to escape till the roots are pulled or broken off.

Probably the best time for blasting stumps is in the spring while there is a little frost yet in the ground and the soil is the dampest. The fall is most satisfactory in some sections. In soil where water is to be found very near the surface, the use of powder is at its best. Sandy and gravelly soils allow too much of the force of the explosion to pass downward to do efficient work. Strong subsoils, such as clay or stone, give good support to blasting. E. V. VORIS.

### An Automobile Hint

TRAVELING would be easier if there were road-signs used more frequently. Now it is exceptional to find road-signs. Some states indicate a trans-state road by signboards every now and then, and no other signs are considered necessary until after an accident, or a series of accidents, occur.

The following signs are suggestions. They are more than that, for they are recommended by the American Motor League and are in use in some places. They are for farmers and city folks who use automobiles, and, of course, are for those who are not familiar with the roads. That means two thirds of the travelers.

If the farmers are organized so that all understand the signs, such signals become of great benefit.



These should be on white posts—only the symbols being black. They should be placed between two hundred and three hundred yards from the points to which they refer. C. E. GOUVEIA.

### Ratless Crib

EVERY farmer knows about rats and corn-cribs and how well they seem to agree. This includes mice as well. Now the difficulty for the most of us is to keep these two things separate.

Some time ago an old retired farmer who had recently purchased another farm told of his rat and mouse proof granary. This building had been in the same place for twenty years and as far as anyone knows there has never been a rat in it.

The piers were made two feet high and of brick. On top was a sheet-iron piece about one foot larger on each side than the top of the pier. All eight piers were fixed

in the same way. This in itself would be sufficient to keep the rodents away if it were not necessary to get into the building. Instead of the usual steps fastened to the wall, there were steps made separate and set up against the building. They were removed as soon as the work inside the granary was finished. That, I think, was the secret of the ratlessness of this building. Seems rather simple and seems like lots of bother to take these steps away every time grain is wanted, but isn't it worth the time?

Another scheme to avoid the rats is to screen the crib with fine netting small enough for the ordinary mouse. This costs much money, but it is worth it.

R. E. ROGERS.

Almost any kind of a shed will beat the open air for machinery.

Why should the farmers preach economy of operation of railroads while they are careless of their own highways?

### Farmer Schoolmaster

MY FATHER placed me in the teacher's chair when I was sixteen and I held it fifty-two years. When approaching the end of my half-century, it came to me that I must soon vacate, and having been unable to save much from my meager salary it behooved me to look about for some employment.

My father had left me a small farm, but one entirely inadequate to my support. It was poor and hilly, seemed to wash in every direction. Nevertheless, I determined to see what I could do.

First, I selected a small plot—stiff soil with a good clay subsoil. I plowed it as deeply as I could, applied ashes from time to time, wood-pile dirt and rotten chips, leaves, sweepings from the hen-house, stable litter when I could get it, litter from the hog-pen, dirt from the woods; in short, everything that would add humus or make the soil fertile. One year I grew corn upon this lot, another, potatoes, and so on. I picked up every stone that made its appearance until the spot was in fairly good condition.

Then the alfalfa fever struck me and I gave it a good plowing, broke every clod with a hoe, raked it and rebroke the fine clods; then harrowed it till the soil was thoroughly pulverized, when I sowed inoculated alfalfa-seed and harrowed them in with a tooth-harrow. I went off to my winter school, and when I came back in the spring, I had a beautiful alfalfa-patch. I cut it four times that first year and have cut six crops from it every year since; however, the native grasses are taking it now and I will soon have to turn and resow. I believe in giving as well as taking, so I top-dressed this plot one year with lime, another year with cheap commercial fertilizer and again with ashes. This plot has given pleasure to many passers-by and has encouraged others to try alfalfa.

Being so successful with this experiment, I thought to try my hand upon a larger area, so I broke up an acre of gray, gravelly soil and worked at it until it was finely pulverized and many of the stones picked up. It was so poor that I thought if I applied three sacks of bone-meal and ten barrels of lime it would produce as well as good soil. I did so and immediately sowed my inoculated alfalfa-seed and went off to school again; but, alas, when I came back, instead of a beautiful patch of alfalfa, I had a fine patch of sheep sorrel. I turned this under and sowed peas, which were cut for the cow. Rye was sown and turned under the following spring. Peas were again put on the land. I kept this up for a year or so, and now I have a pretty patch of grass; orchard, herd and meadow oats mixed. There are some galded spots, but I am applying to these sweepings from the hen-house and ashes. For some of them I can get stable manure, and thus I hope to bring out these ugly places and make the field uniform. I have enlarged the field to two acres. From your pages and my own experience, I have learned to let some weeks intervene between the scattering of the lime and the sowing of the fertilizer. I can see the improvement in the soil and am hopeful of making a pretty lot of it.

I have found wood-ashes to be of inestimable help to soil. I once had a sweet-potato patch that looked so badly I applied a big handful of ashes to each plant. The plants were soon as green as could be and growing nicely. The next year I sowed oats on this spot and the growth was very much finer, where the ashes had been applied. The difference was perceptible for several years.

While experimenting on these lots, I also tried mixed grasses suited to thin pasture land and found it quite a success. I also carried on my work upon a garden-spot. Here I grew corn, cabbage, beets, beans, tomatoes, potatoes, pumpkins, melons, turnips, rape, mustard and other vegetables. Sometimes I failed, in fact I failed in some of these things every year. However, from every failure I learned a lesson. I watched your columns and looked out for something to suit my needs and often found it.

I propose taking up the poultry business and in the near future I hope to get some bees.

Thus you see what a farm and a farm paper have done for me. J. P. A. HILL.

### Carries Threshed Grain

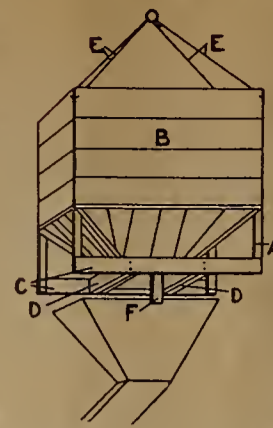

THIS sketch shows a device which will take the place of several men. The hardest work in our community at thrashing-time is the carrying of the sacked grain from the machine to the granary. To do this satisfactorily several men are required. This device cost me only three dollars. It is attached to the hay-carrier the same as

a hay-fork and holds seven sacks of oats. One man, and a boy to lead the horse, can operate it successfully.

The points may be outlined as follows: A is a two-by-two oak piece thirty-eight inches long. BB are one-half-inch basswood boards, thirty-six inches long. CC are pieces one by three by thirty-six inches. DD are one by three by thirty inches. EE represent wires connecting the carrier with the hay-traps. F is a piece two by four by twelve, which opens the sliding door as it strikes the hopper, shown just below the carrier.

When filled, this device is fastened to the blocks and follows the track until the sliding door strikes the hopper. It takes about a minute to empty the contents into the hopper, which is connected by a spout to bins below. In drawing the carrier back, caution must be used to do so slowly. The hopper, as arranged for this carrier, is thirty-three by twenty-five by thirty-six. E. D. KING.

### Starting a Muskrat Farm

A READER in western New York has about two hundred acres of marshy land which has quite a population of muskrats, or "musk beaver," with which he is disposed to launch out into rat-farming. How proceed?

Funston Bros. & Co., St. Louis, the largest fur concern of St. Louis, Missouri, advise encouraging the rats to thrive and multiply by means of feeding some unsalable apples, beets or parsnips, furnishing some coarse grass or straw for nesting purposes and leaving them undisturbed without trapping or hunting for two or three years.

B. F. W. T.



### The Latest Agricultural Reading

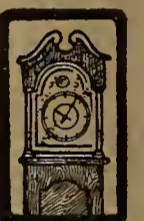

**The House-Fly**, by L. O. Howard, Ph. D., contains much practical information about the pest so common in American homes. The author shows how the fly lives and develops, how it carries disease, and how the evils of the fly may be remedied. The various forms of flies are mentioned and described. Pages, 312; illustrated; price, \$1.60 net; Frederick A. Stokes Company, New York.

**Animal Competitors**, by Ernest Ingersoll, points out the extensive ravages in crops, orchards or granaries by rats, mice, gophers, rabbits and other rodent pests. Methods of getting rid of these pests are described. Likewise, devices for trapping some animals valuable for their fur. Pages, 319; illustrated; price, seventy-five cents net; Sturgis & Walton Company, 31-33 East 27th Street, New York.

**Rural Denmark and Its Lessons**, by H. Rider Haggard, contains in pleasing form a story of agricultural conditions in that country famed for its progressive farming. What is given indicates a first-hand knowledge of the subject matter. Consequently the lessons from the farms large and small are forceful and interesting. Pages, 335; illustrated; price, \$2.25 net; Longmans, Green & Co., Fourth Avenue and 30th Street, New York.

**Electric Light for the Farm**, by Norman H. Schneider, tells of low-voltage electric-lighting with the storage battery and the wiring of houses for the electric light. Special reference is made to farm conditions. Pages, 170; illustrated; price, \$1.00; Spon & Chamberlain, 123 Liberty Street, New York.

### Of National Importance

Farmers' National Congress, Columbus, Ohio. October 12, 1911

The International Dry-Farming Congress, Colorado Springs, Colorado. October 16-21, 1911

International Dairy Show, Milwaukee, Wisconsin. October 10-18, 1911

National Dairy Show, Chicago, Illinois. October 26—November 4, 1911

National Creamery Buttermakers' Association, Chicago, Illinois. November 1-3, 1911

# The WINDMILL

light, heat and power for the remnant of the human race. In the interim, between the beginning and the end (where we now are) it makes a greater return to the people in proportion to its cost than any other machine. It does more cheaply, and with less attention, the thing which it is fitted to do, than any other power.

The wind blows everywhere and is free. With a windmill, the expense for oil and repairs is the only one, and that is trifling. An engine requires much more in the way of oil and repairs, and fuel — which is the great expense — has to be added.

**The windmill does not require an experienced man to operate it.** It is so simple that anyone can understand its workings.

A well-made windmill is a durable machine. The driving shaft of a windmill runs only about one-fifth as fast as the crank shaft of an engine of the same power. A good windmill will outlast several engines doing the same amount of work.

**The best farmers, everywhere, use windmills** generally for pumping water. In every progressive farming community the windmill is the most conspicuous object. It towers above most groups of farm buildings.

All the world knows that the Aermotor Company made the first steel windmills and steel towers, and made the steel windmill and steel tower business. It is believed that, since the business was fairly established, it has made, and continues to make, more than half the world's supply of windmills. In the Aermotor the plan of back-gearing was first introduced into windmill construction. By this means the power of the swiftly running wheel is utilized without operating the pump too fast.

**The peculiar form of Aermotor wheel,** which gives it great power, also enables it to run in the lightest breeze. No windmill has yet been made which equals the Aermotor in its light-running qualities. The form of the wheel is exactly right.

Simplicity is another of the important features of the Aermotor. There are no complicated parts to get out of order. There are no devices requiring skillful adjustment. Every part is solid, substantial and durable.

The main bearings of the Aermotor have large dust-proof oil pockets which afford the best possible means of lubrication. The other bearings have automatic oil cups.

**The Aermotor has thoroughly demonstrated its staying qualities.** In almost any community Aermotors can be found which have been doing duty for fifteen, eighteen or twenty years. And these old Aermotors were made before the days of the heavy gears and the shaft-carrying arms which are easily turned in their sockets so as to give new and perfect bearings for the shafts in case they have become worn through overloading or neglect. The present Aermotors are sure to be more durable and serviceable than the earlier ones.

**The galvanizing of Aermotor outfits** has had much to do with their popularity. Aermotor galvanizing is real galvanizing. It is the best that can be done and will last a lifetime. Aermotors which were galvanized twenty years ago are as good as ever.

**The Aermotor Company has been building for the ages.** It has always been working toward the building up of a great and permanent business. It has succeeded so well that Aermotors are as well known in South America and South Africa as in the United States. Dealers in Aermotor goods are found everywhere. When you want anything in the Aermotor line you can get it and get it quickly.

## AERMOTOR PRICES AND POLICIES

When the Aermotor Company commenced the manufacture of the windmill, it reduced the cost of wind power to one-sixth of what it had been. It advertised its prices. It made the best thing that could be made and at the lowest price at which it could be made. It uses no traveling men. It made so good an article that one-half the world's business came to it and stayed with it. It is doing the same thing with the gasoline engine. Where one goes others follow, and we are

turning them out in great quantities, to the delight of Aermotor friends everywhere. We could send smart traveling salesmen to see you and persuade you to pay \$25 or \$50 more for a windmill or an engine, and it would be worth it—not to you, but to us. But there are plenty of reading and thinking men who prefer to save their own time and money and deal in the Aermotor way.

## AERMOTOR GASOLINE ENGINES

**Wherever a windmill is suitable for the work,** an Aermotor furnishes the cheapest and most satisfactory power for pumping. But there are some places where a good wind exposure cannot be had. There are other places where power is wanted only temporarily. Sometimes tenants are obliged to supply their own power for operating the pump and do not wish to put up a windmill which they will have to leave behind them when they move. To supply the demand for a pumping power for such cases the Aermotor Company makes a gasoline engine which can be attached to "any old pump" in thirty minutes. It is sold complete and ready to connect to the pump for \$37.50, F. O. B. Chicago.

For ranch purposes, or for handling large quantities of water, a heavy, back-gearred pumping engine is supplied for \$100.00, all complete, ready to receive the well fittings, which can be set up in working order within an hour after it is received. It is capable of raising sixty barrels of water an hour to an elevation of one hundred feet.

**For running machinery,** the Aermotor Company makes a line of General Purpose Power Engines. The 2 H. P. Hopper Cooled Engine sells for \$75.00, 4 H. P., \$125.00. All prices are F. O. B. Chicago.

These engines are fitted with the Aermotor galvanized steel pulleys. Who ever heard of a galvanized steel pulley? No one. Nor did anyone ever hear of a galvanized steel windmill, or steel tower, until the Aermotor Company produced them. These galvanized pulleys are sure to revolutionize the pulley business. They are light, strong, cannot be broken, and are wonderfully cheap. **A complete set of seven pulleys** for a 2 H. P. engine is sold for only \$8.00. A set of seven pulleys for the 4 H. P. engine sells for \$11.90. We always furnish one pulley free with each power engine; but to anyone thinking of buying an engine, who writes us within one week from the appearance of this advertisement, stating in what paper he saw it, we will furnish free, with each 2 H. P. engine or larger, \$5.00 worth of pulleys of any size which you may select for either engine or line shaft, provided the order is sent in before January 1st, 1912. Pulleys for the line shaft—being used where they are protected from the weather—are not galvanized.

## MAGNETO WITHOUT EXTRA CHARGE

All Aermotor Power Engines are fitted with a magneto without extra charge. Batteries are not used with these engines. You have no ignition troubles when you buy Aermotor Gasoline Engines fitted with the Aermotor magneto. We don't believe that anyone who once sees an Aermotor Engine run with magneto will take any other engine as a gift. For full particulars write

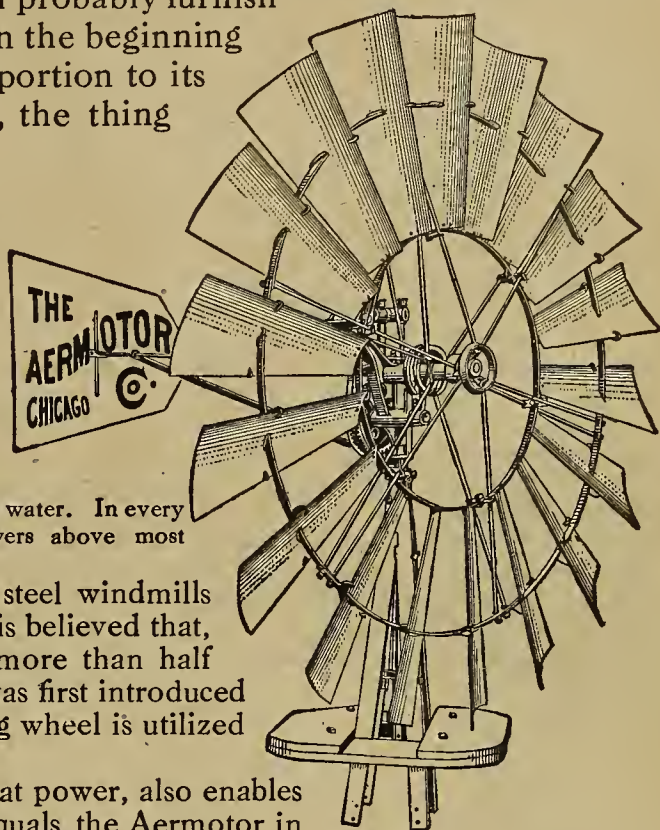

Still Smiling  
The Aermotor has been smiling at the breezes for 23 years

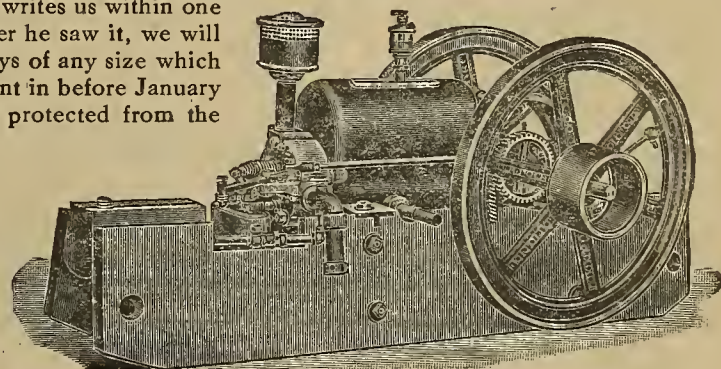
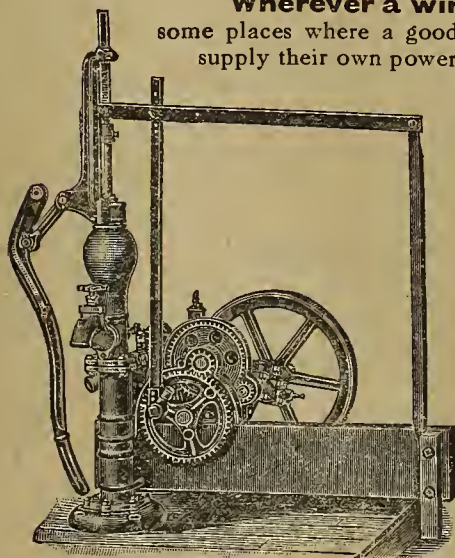
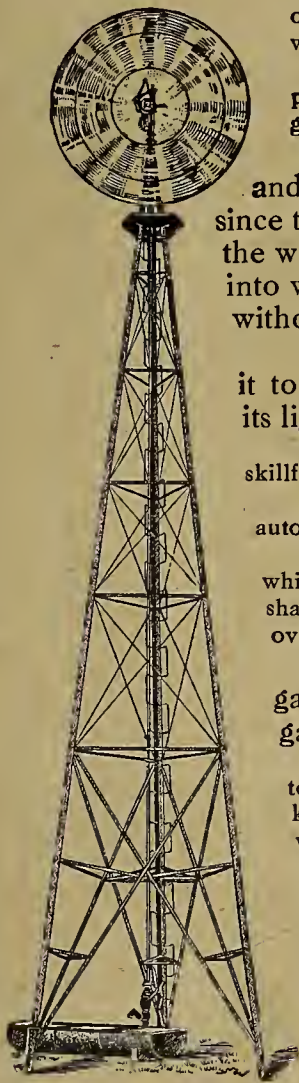

AERMOTOR STEEL PULLEYS

Diameter of Pulley, Inches.	Width of Face, Inches.	PRICES.	
		For Engine	For Line Shaft
6	7	.75	.95
8	9	.85	1.05
10	9	.95	1.20
12	9	1.10	1.40
14	9	1.25	1.60
16	9	1.45	1.80
18	7	1.65	2.10
20	7	1.90	2.40
22	7	2.15	2.70
24	7	2.40	3.00

Compare these prices with those you have to pay for any other pulleys

**Aermotor Company** 2516 W. 12th Street **Chicago**

## This Beautiful Sugar-Shell Without Cost

WE WANT to send you this beautiful Oxford Silver Sugar-Shell, made by Rogers Company. It is made of heavy plate silver.



Entire spoon is six inches long, handle is four inches long, beautifully carved and embossed in the Narcissus pattern and finished in the popular gray French style. The bowl is two inches long and one-and-one-half inches wide, with a beautifully carved and deeply embossed Narcissus in the bottom. It is finished in highly polished silver plate. We guarantee this spoon to be genuine Oxford Silver Plate. If you are not perfectly satisfied, you can return the spoon and we will refund your money. We want to send it to you just to show you how you can earn a set of six Oxford Silver Teaspoons just like it without a cent of outlay, for a slight favor on your part.

### SEND ONLY TEN CENTS

and one three-month subscription to FARM AND FIRESIDE, and we will mail you, in addition, a genuine Oxford Sugar-Shell, as described above. The Sugar-Shell will be yours to keep, all we ask is that you agree to show it to two of your friends.

Address all orders to Farm and Fireside, Springfield, Ohio

## Poultry-Raising

### The Appetite of Ducks

CONCERNING this, I would like to submit the testimony of Mr. John Robinson, a poultryman of large experience, one who knows the experiences of breeders as perhaps no one else does, and who has been for years editor of one of our most reliable papers. He says, "It is often said, even by those who should know better, that it is impossible to satisfy the appetite of a duck. Such statements lead people to think it much more expensive to feed ducks than to feed other fowls. A flock of grown ducks will not eat more than an equal number of average chickens, nor does it require more food to grow a duck than it does to grow a chicken of the same weight." Mr. Robinson also says, "In most places, poultrymen growing both chickens and ducks will usually find the latter more profitable as long as their home market is not overstocked."

I wish to call especial attention to the clause, "of the same weight," above. A young duck does eat greedily, but it also grows by leaps and bounds, figuratively speaking. Recently, I received a letter from a man who knew: "I never in all my experience with poultry saw anything grow like an Indian Runner duckling. My ducklings are the curiosity of the neighborhood. At the age of five weeks, I haven't a duckling that weighs less than a pound and a half. I cannot afford to handle anything but utility stock. I have investigated rather exhaustively, and with pure-white eggs I can well afford to take the chance on making a market, but I would not have the ghost of a show if I had green eggs."

In a second letter, this (Texas) correspondent says: "Ducklings will be seven weeks old to-morrow. I also have a lot of Barred Rock chicks which are three days younger. This morning I concluded to weigh some of them and compare them. All my ducks weighed more than two pounds, two of them tipping the scales at two and one-half pounds (each). My largest chick weighed about three quarters of a pound. I wish I had seven hundred of the ducklings at the present time; they would be worth good money even as market fowls. When I first set my eggs, poultrymen advised against it, on the ground that they would eat me out of house and home."

In order to have some testimony of my own, I personally weighed ducklings and

Columbian Wyandottes yesterday. For added interest and profit, I included the geese. Treatment of all has been of the best. At twenty-six days old the White Indian Runners weighed one pound each; the Columbians weighed four ounces each. Runners sixty days old weighed three pounds each, Columbians forty-one days old (the nearest in age I have) weighed less than a pound, some as low as half a pound, they being much less even in size than the ducks. The Embdens were so near of a size that we could not determine which was larger or smaller. The one weighed tipped the scales at five pounds, being not far from a month old. At this age we often say they "double" in size daily. A little later they do not gain quite so rapidly, but I know of no other animal that grows so fast, especially considering that they are, proportionately, quite light eaters.

Since the Runners do not pose especially as market ducks, the above counts for more than Pekin testimony. The Pekins grow even faster than the Runners, and, of course, eat more in proportion.

Matured water-fowls are not exceptionally large eaters, rather the reverse. Especially is this the case with the geese. And they will eat cheaper foods than will hens, and thrive well. In other words, the "food question can be dodged" so as to favor the pocketbook. And there isn't any food question, as between growing chicks and growing ducks, if you consider the gains made. Or, if any, it is in favor of the ducks. The losses are virtually none, with good handling.

The one point of question—actual question—is whether the farmer has salesmanship enough to make a market for his duck-eggs. Surely, no one believes that eggs will go begging when eggs are scarce. Doubtless the Indian Runner is a better proposition for the South than the North—possibly better for the intermediate range of states than for either. C. S. VALENTINE.

Just as sure as we have no particular plan for marking and culling among the poultry, just that sure we may expect to retain unprofitable hens.

### System of Poultry Accounts

A KENTUCKY subscriber wishes to know how to proceed in establishing a systematic form of bookkeeping for his poultry business.

The most satisfactory, simple method of keeping poultry accounts is to use the ordinary carbon copy sales pads in common use in the department-stores. This is convenient and also combines the feature giving to the purchaser a copy of the record of the sale. From this book the accounts may be posted on what may be called a classified day-book in which columns are provided, reading from left to right across the page—the date and the name of the customer, a column for the total amount of the sale and another column for the total amount of the purchase. The remaining columns are used for the various departments into which the poultry operations may be divided; namely, "eggs for hatching," "eggs for market," "stock for breeding," "stock for market," "fruit," "vegetables," "Miscellaneous," etc. Frequently one page is used entirely for sales, while the opposite side of the page is used exclusively for purchases, in which event columns would be provided for feed, labor, tools, permanent improvements, taxes, insurance, etc. This system requires a book of special ruling, but is so simple in the matter of time required to foot up the columns at any time that it is exceedingly workable as compared to a double or single entry system of bookkeeping where regular accounts are kept. The system described is applicable, primarily, to moderate-sized poultry plants. J. E. RICE.

### Reasonable Poultry Profits

[CONTINUED FROM PAGE 5]

their flocks by marketing all they can spare, and thus prices are kept down for some time. Then they limit production until there is a shortage and prices slowly rise again to good figures, when they again increase production, fill the markets and send prices down. The wise poultryman will watch these fluctuations and take advantage of them.

From a flock of one hundred and fifty pullets and hens I should expect to clear five hundred dollars in one year. I have done much better than that when prices were extra good. In the poultry business, as in any other, the progressive, up-to-date man wins, while the careless and slovenly go down. The longer a live man is at it, the more he can make, for he learns things every year that increase his efficiency. He who sticks to one good variety, and keeps it up to the highest type as market stock or layers, becomes known throughout his section as the Barred Rock, Wyandotte or R. I. Red man, the same as a thorough cattle-breeder becomes known as the Shorthorn, Holstein or Jersey man, and he gets business that never comes to the man who keeps only mixed stock, and it is business that is profitable. His stock not only brings top prices in market, but it attracts those who want good breeding stock and are willing to pay good prices for it.

For one hundred and fifty hens I would have three houses—fifty in each. Each house would have an open-front shed attached to it and be in a good-sized yard, so that I could shut the birds in at any time. The breeding stock would occupy one house, the laying stock the other two. By making the perches just about large enough for the number of fowls allotted to each house, the fowls when on range will rarely crowd into one of them. Between the first of November and the first of April we have many cold, stormy days. If the hens have full liberty such days, they will stay out and get their feathers very wet, and are almost certain to take cold and stop laying. By confining them to their yards at such times and feeding in the sheds they will not go out much.

There is a great deal of nonsense written and printed about feeding poultry, and some of the bills of fare prescribed would cost more for one day than all the eggs they could lay in a week would bring in market. I feed corn, wheat, oats, bran and middlings or shorts. I feed corn on the cob, cutting each ear into two or three pieces, and make them pick it off. They feed slower and each gets a more equal share, while the exercise does them no harm. If ear-corn cannot be had, I would crack the grain to about the size of wheat. This is much better than feeding the grain whole. Wheat and oats are excellent for mixing with the straw in the scratching-sheds when the hens are shut in by bad weather. When the ground is dry, they may be scattered over quite a large surface. In either case the hens will get all of it. Kafir-corn, sunflower-seed, millet and buckwheat are also excellent for variety. Bran and middlings are used in the mashes, and with the addition of crushed oyster-shell are kept before the hens all the time in special feeders which keep the mixture dry and prevent waste. Stinting hens, or feeding them damaged grain, or compelling them to dig all of their food out of litter means fewer eggs and less profit. My hens always go to roost with full crops, and I see that they always have an abundant supply of water.

I aim to get out my first hatches between the first of March and first of April, depending somewhat upon the forwardness of the season. Generally prices are highest before these chicks get on the market, but the cost of caring for extra early chicks and the inevitable loss cuts out all the extra profit. Eggs usually bring a very good price during February and I prefer to sell them and get the price in my pocket instead of hatching extra early chicks from them and going to the trouble and expense of raising them to market size. The early-broiler idea is pretty good in theory, but fails to pan out well in practice. I continued to carry on my hatching operations up to the last of July, getting the chicks out in lots to take the places of those sold earlier. Summer chicks are easily raised because the weather is warm and insects and green food abundant. If they are well fed, properly cooped at night and kept free of mites, lice and fleas, they grow rapidly and bring a price that makes them profitable.

If one has a good range, either open fields or woodland, and is full of vim and sound business sense, he will soon find that he can profitably manage more than one hundred and fifty hens. If his range is limited, fifty to a hundred can be more profitably handled. One must be careful not to overcrowd his yards or houses. The cooping process does not pay because cost of care and food cuts out all chance for profit. The work of managing one hundred and fifty hens so as to get the maximum of profit out of them is not hard, but one must be on hand and leave nothing to chance or "luck."

You may soon forget how much an article cost. But if it gives perfect satisfaction, you will long remember that fact. Thus quality is a more important attribute than price, and in buying anything for the farm or the home it is well to remember this.

In the advertising columns of FARM AND FIRESIDE you will find wares of this quality class only; for we are particular about the character of goods which are offered to you. Therefore, patronize those you see there with the complete assurance that you will receive prompt and satisfactory attention.

# TEN THOUSAND PAIRS PER DAY

**Means A Lot More**

than the bare fact that we are the greatest manufacturers of rubber boots in the United States.

It means that hundreds of thousands of farmers have worn and liked the rubber boots we have been making for the past 45 years.

## Woonsocket ELEPHANT HEAD Rubber Boots

are made of the finest materials obtainable; by expert labor, in a mill devoted exclusively to the manufacture of rubber boots—boots made to stand hard knocks and to wear long. All Dealers. Always

**Look for the Elephant Head Trade-Mark**

All Woonsocket boots and shoes have the Elephant Head trade-mark.

WOONSOCKET RUBBER CO. WOODSOCKET, R. I.

ANYBODY CAN LAY IT.

## Rubber Roofing

Warranted For Twenty-Five Years.

**FREIGHT PAID** To Any Station East of Rocky Mountains, except Texas, Okla., Colo., N. D., S. D., Wyo., Mont., N. M., La., Ga., Ala., Miss. and Fla., on all orders of three rolls or more. Special Prices to these States on request.

ONE-PLY . . . . .	Weights 35 lbs.,	108 Square Feet,	\$1.10 per roll.
TWO-PLY . . . . .	Weights 45 lbs.,	108 Square Feet,	\$1.30 per roll.
THREE-PLY . . . . .	Weights 55 lbs.,	108 Square Feet,	\$1.50 per roll.

**TERMS CASH:** We save you the wholesalers' and retailers' profit. These special prices only hold good for immediate shipment.

**Indestructible by Heat, Cold, Sun or Rain.**

Write for FREE SAMPLES or order direct from this advertisement. Satisfaction guaranteed or money refunded. We refer you to Southern Illinois National Bank.

**CENTURY MANUFACTURING COMPANY, Dept. 624, East St. Louis, Ills.**





# The FARMERS' LOBBY.

**T**HE County of Buncombe is located in North Carolina. The name comes down from colonial days and is perfectly respectable. The man who gave his name to the county—and to ignominy—was dead many decades before the modern meaning attached itself to Buncombe. A young man arose who handled the buncombe (common noun) so skilfully that the county became famous and the name descriptive of that variety of intellectual illumination which is neither intellectual nor illuminating, but is supposed to get the votes.

The Standard Dictionary avers that buncombe is "inflated or bombastic speechmaking only for effect; any specious utterance of a legislator made to please his constituents." And that "the word is supposed to have had its origin in the remark of a member of Congress from Buncombe County, North Carolina, that he was 'talking only for Buncombe.'" "Balderdash" and "bombast" are suggested as available synonyms.

## Sends Lawmakers Home to the People

**T**HESE literary, historic and philological reflections are inspired by consideration of arguments of late given currency in the Canadian campaign on reciprocity. Reciprocity was allowed to lie fallow in Canada until adopted in the United States. Then they pressed it in the Canadian parliament, and the premier, Sir Wilfrid Laurier, being unable to force a vote early, prorogued parliament on the issue. That is, he sent parliament home and ordered election of representatives on this issue. When he can't make his parliament perform, he can send it home to get orders from the people; and he can go out and ask the people to give the right sort of orders. If they do it, he wins; if they decide against him, he loses. It is the finest, biggest, noblest gamble that the great game of politics has ever devised. I wish we played it that way in this country.

For example, last December, Congress met and the President made an issue of reciprocity. Congress would not act on it, and the President couldn't make it act. The session ended on March 4th without any decision.

If this had been Canada or Great Britain, the administration would have waited a reasonable time, and then would have sent Congress home for orders from the people: dissolved Congress and called new elections.

The new elections would have been on this issue, because it would have forced the deadlock and the dissolution. Consequently, the new Congress would know just what it was to do. If the majority was for the government, Congress would proceed to ratify reciprocity; if against, the government would resign and a new one, in harmony with the new national policy, would go into office automatically.

But, this not being Canada or England or Australia or Zambesi or Lhassa or any other place except the U. S. A., that plan wasn't in operation here. The President had to wait till the session ended, and then called the new Congress—which had not been elected on reciprocity—in special session. He informed this Congress that he wanted the reciprocity ratified, and sat back to see what would happen.

## Legislators Sometimes Flop Completely Over

**W**E ALL KNOW what it was. Congress ratified the Canadian agreement, and then passed a row of tariff bills. The President vetoed the whole lot of them, and in his speech at Hamilton, Massachusetts, explained that Congress was not expected to do anything except pass the reciprocity matter: that was all he had asked it to do, and why, forsooth, should Congress assume to do more or less than the President asked it to do!

Buncombe, buncombe, all the way along. The President demanding ratification of his pact on the ground that he wanted to cheapen the cost of living, and then vetoing the bills which looked to reduction of duties on other things which would actually have reduced it! Against this, set off the spectacle of gentlemen voting against reciprocity on the ground that it was going to ruin American agriculture: the same gentlemen, in many cases, who only two years earlier had solemnly assured the country that the agricultural duties of the Payne-Aldrich and Dingley acts were unnecessary and useless! Mr. Aldrich lined up his standpat forces in support of the agricultural duties, on the ground that, if the duties were repealed, American agriculture would suffer severely. Two years pass, and the Republican faction, which had voted WITH Aldrich FOR those duties, flopped completely and voted to take them off,

## New Fables in Reciprocity By Judson C. Welliver

while the people who had been insistent that these duties were of no use turned just as complete a somersault and voted to RETAIN them lest their loss should inflict disaster!

Without reference to the question which crowd was RIGHT and which time it was right, what is to be said for the sincerity of either?

Then take the various arguments on the reciprocity bill and the tariff bills. The President wanted reciprocity without waiting for the tariff board to report whether it was right or wrong; whether the reduced duties represented the difference in cost of production at home and abroad, "plus a reasonable profit for the American producer." Oh, yes, it was easy enough for him and his reciprocity commissioners to know the comparative cost of producing agricultural staples at home and abroad. Utterly unnecessary to bother the tariff board!

But both houses of Congress—one Democratic and the other Republican—put up to him the proposal to reduce the duties on wool! Then he promptly retorted that it would never do to act till the tariff board could complete its studies and tell what it thought should be the measure of reduction. Congress, of course, might not take the tariff board's word; but it must wait till it had had the chance, anyhow.

And so the wool, the cotton and the steel bills were vetoed.

The President's position looks contradictory. Yet it was no more contradictory than the positions of those Republican revisionists who two years previous had insisted that there must be a tariff board, and after a long struggle had got it written into the law. They insisted that every step in revision ought to be guided by the wisdom of tariff experts. They were sure that if the board were created, it would smooth down the difficulties in the road to revision.

But before that board could report on the schedules, these same people wanted to go ahead and revise!

Buncombe, and more of it!

## Certainly Reciprocity Passed

**T**HE standpatters two years ago opposed the tariff-commission idea, fought it to the last ditch, pared it down from a commission to a board, took away about all the substantial powers that ought to have been given to it, and then let it sneak into the bill, a shadow instead of a substance. They wanted no tariff commission, and would have as little of it as possible.

Yet these same standpatters, when the demand for revision was being pressed in Congress, suddenly fell back on the tariff board that they had so sincerely hated to create, as an excuse for delay about revision! They were suddenly converted to the tariff-board doctrine; they insisted that it would be the height of unwisdom to plunge into revision without the guidance of that accurate, detailed information which could be secured only through the thorough inquiries that could be conducted only by a board of experts!

Buncombe, and also balderdash!

Well, the reciprocity business passed and the scene changed. Canada would now look into this reciprocity thing, and decide whether it, also, would approve.

Take Canada by and large, it is rather more English than England, more loyal than the ministry at Downing Street, more suspicious of the United States than London would dream of being. The fact that our Congress had ratified the agreement was calculated to make our Canadian cousins instantly suspect the presence of a Senegambian in the fuel heap. Why should we favor the project, if it were not bad for Canada? That is the best argument that can be adduced against the treaty anywhere in Canada.

Here in the States we are wont—some of us, anyhow—to assume that it is possible for a trade to be a good thing for BOTH SIDES. If one side is to be skinned in every trade, everybody ought to quit trading.

Yet folks have been trading ever since civilization began. It is the basis of society. The truth is, in most trades, BOTH SIDES GAIN: each gets something it wants more for something it wants less.

But the Canadians are being urged to believe that no trade can possibly be a good thing for both sides; and as Uncle Sam has snapped up this reciprocity bargain, it must be the evidence that Uncle Sam has something

up his sleeve. So Canada ought to reject the trade while there is yet time! More buncombe.

Take our trusts as bogey men in this big game of bunk. While reciprocity was before Congress, those of us who were on the ground here, observing just as carefully as we could, using our eyes and what little sense had been given to us, convinced ourselves that most of the big trusts were OPPOSED to reciprocity. They came down here with tears in their eyes to assure Congress that reciprocity was a step toward taking down the tariff bars. It would take off the top rail, and a few of the bigger and more powerful critters would jump over, and pretty soon the fence would be destroyed. The only safety, averred these apostles of the policy of Chinese-wall isolation, was to keep the fence untouched, or, if anything, to build it higher and stronger.

Reciprocity was ratified, not with the help of the trusts, but IN SPITE OF them. Nobody could have been about Washington the last year and have any sincere doubts on this point.

## A Lot of False Argument

**N**OTE then how skilfully the Canadian bunko-steerers use the American trusts. They have been warning Canadians that the reciprocity measure passed the Senate because the trusts wanted it. "Can't anybody see that?" they have been demanding. "Don't we all know that the trusts own the Senate? Didn't the Senate pass it by a big majority? Then how can it be doubted that reciprocity is the trust game?"

The Canadians can be excused for taking some interest in that argument. The Senate HAS been so long held up to execration as the Gibraltar of the special interests that it is not remarkable if the Canadian brother is a bit dazed when he tries to make himself believe that the trusts got something handed to them, right on the floor of the Senate.

Of course, the Canadians don't understand all the factors in the situation. If they did, they would know for one thing that most of the trust senators finally did not vote for reciprocity, and that most of those who did vote for it did it mainly because that for a complication of political reasons they couldn't help themselves.

But the buncombe goes in Canada, just as various varieties of it go in this country. They are telling the voters in Canada, who are to hold their election on this issue in a few days, that the great American trust conspiracy is now perfected. The big scheme of commercial annexation of Canada to the Wall Street money power is to be pulled off without further delay. Reciprocity will bring Canada within the Wall Street money power's sphere of influence. Nothing but the tariff has been keeping the great American octopus out of Canada anyhow, and with the tariff once removed it will be all over for poor little Canada. The octopus will move right in and take possession!

So you see how the octopus serves one purpose on one side of the line, and another on the other. President Taft's supporters profited by our belief that old Oc was against reciprocity; the Canadian conservatives are making capital out of the theory that Oc is for it, and that he actually invented it as a means of dismembering the British empire and sucking Canada right into his alimentary system, to be digested at leisure!

## How It All Affects Canada

**A**ND that sort of thing has been making votes against reciprocity in Canada, too. It seems that people on either side the line don't care so much about the facts and the merits. They will fall for the bunk every time, if it is handed across to them strong and raw enough.

They are breaking down Sir Wilfrid and reciprocity, right in Quebec, with all sorts of buncombe. It is, after all, worse than any specimen of balderdash I have found in use on our side of the line. The Canadians appear to be even more expert in shooting the bunk than we are here; and I feel like taking my hat off to them for it, for until I looked into the Canadian arguments on reciprocity, I didn't think the array of balderdash hatched up for use in the States could possibly be paralleled anywhere else.

I really think the Canadians have beaten us at our own favorite game.

The result in Canada? The best information here is that reciprocity is likely to be endorsed by a greatly reduced majority for Sir Wilfrid; but anything may happen. Anyhow, the year's crop of buncombe is the largest in recollection of Canadian politicians now living.

# A Romance of Statuary Hall

## How Clara Malby Saved the Old Homestead

By Paul Elting



SUCH a pitilessly hot day, with the Washington sun beating down and striking back from the asphalt pavements and marble walls, and with even the thousand trees of Capitol Park shrinking breathlessly from the glare.

Forth and back from Senate Office-Building to the Capitol, and from the Capitol to the House Office-Building, Clara Malby had been hurrying since the doors were opened; her heart falling from hope only to rise from despair with girlish courage both fine and fruitless. The senators and the representatives from her state, from whom she counted so much through the letters she had from the clergyman, the postmaster and the squire of her home village, would not see her; they had gone out; they were on the floor, or in committee-rooms or at luncheon; they were home, asleep against the fatigues of another night session. They were anywhere and everywhere except on hand to help her; and on the morrow at twelve o'clock the flags would go down, and Congress be adjourned without day.

It was four o'clock in the afternoon, when Clara, a pathetic little figure, in her neat traveling suit, passed through the vast rotunda, under the shadowy dome, tightly clasping her bag with its precious contents. Behind her was the whirring rush of the legislative mill, for the Senate was still in session; but as she approached the House wing it was quiet and still, for the popular branch had taken a recess until eight o'clock. Members and officials had made haste to leave the close, superheated chamber for a few hours of rest; while the thunder-heads that were now sweeping down and across the Potomac from Virginia, with the boom of artillery and the flash of winged horses, had sent the visitors scurrying to their hotels. Statuary Hall, when Clara entered it, was deserted, save for the ghostly circle of marble worthies, tall and white, looming majestically in the gathering gloom. The girl was faint, weary and downcast. She had not eaten and she had been on her feet since dawn. Her heart no longer reacted buoyantly. She threw herself into one of the easy chairs in that corner of the great hall which is fitted up as a reception-room for ladies and in a moment was asleep like a tired child.

The dreams that followed were innocent pictures of Clara's interests and purposes, confused yet distinct; the old home by the broad river, with the prairie sweeping endlessly away from the sycamores like the sea from a wooded cape; her mother's sad and anxious look and God-speed as she had started forth on the desperate quest to save this fair and tranquil domain which her father had created out of the wilderness, and then, again and again recurring, the face of Harry Manley, her playmate and sweetheart in the long, sweet years of childhood and youth, before he went away and trouble came.

Once the scene was so vivid and yet so unreal as to rouse Clara from her slumber. She was living over again her last interview with Lawyer Drake; he was maintaining again that the patent granted to the Mulcimer Company was a forgery and a fraud, and that if the records of Meacham, the land agent, slain by the Indians during the very year of her father's entry, could be found, then her mother's title would be cleared and the homestead saved—when right in the midst of it a strange, rasping voice cut across, uttering those very names in a connection unheard of and too good to be true. No wonder she roused, and sprang from her chair.

From behind the gigantic statue of Lewis Cass, Clara peered out cautiously into the hall. There was no one near. Only two men were passing out of the further entrance under the clock, their heads close together in confidential talk, but they were so far away that she could not have heard either of them then any more than she did now. Indeed, it was obvious that she could not have heard them had they been shouting instead of whispering.

But yet it was passing strange. Where had this strange information come from, then? Certainly not from out of her mind or memory, for she had never known, heard or even imagined such a thing. With a sigh of perplexity, Clara tiptoed back to the chair, to sleep again like a tired child.

Presently someone did come into the hall, and so near, too, as to be overheard had he expressed his thoughts. But there was no danger of this shabbily dressed, shifty-eyed individual doing any such impudent thing, who kept looking this way and that only to look again even more longingly on the bag that had fallen to the floor by the girl's side. Oh, no; he kept his thoughts to himself just as he kept anything else he could lay his greedy hands on. The two whispering men had dwindled into specks as they passed through the rotunda. There was no one about; there was no one coming; even the storm was favorable, for the gloom was deep. With a light spring, the thief snatched up the bag, and flitted like another more ominous shadow across Statuary Hall.

He turned into the corridor leading to the Old Library Space, now given over to committee-rooms, where there was a light, and poised listening with an ugly grin of triumph on his face. Then, reassured, he placed his prize on a ledge and began to examine its contents. There were papers, old and grimy, and new and fresh, orderly arranged and tied. There was a handkerchief. Yes, and there was a purse. As he held this poor little receptacle to his ear, grinning the more viciously at the clink, a strong hand caught him by the collar, and forced him along to the circular stone stairs leading to the basement.

"You sneak," said a stern, manly young voice; "at it again after you have been warned repeatedly from the premises. I've no time to bother with you now; but if I ever catch you here again, I'll deliver you over to the tormentors sure. Now, give up and get out."

With a vigorous jerk and a kick the bag was wrested away, and the wretched culprit rolled bumpingly down the stone steps, relieved, indeed, when he was out of sight.

The fine young fellow who had so adroitly executed this double play also examined the contents of the bag. He tucked the little purse, still unclashed, into a corner. He smiled tenderly on the handkerchief and smoothed it into place. He ran over the endorsements of the papers with practised eye; and a look of amazement that settled into one of wise and rapturous comprehen-

"Oh, don't say that, Miss Malby," he interrupted. "You see I know your name. I know your business, too. You see I just had to glance at the papers in order to learn something about the owner. I want to help you. Won't you let me, please? Oh, yes; I know. You are discouraged and heartsore, a stranger in a strange land, with every man's hand against you. I know just how you feel. But it really isn't as bad as all that. There are good men here, brave and true, who, if they had seen your papers as I have, would want to help you, too—yes, and they would do it. The trouble is they are all so busy—they have to guard themselves from the unknown in order to attend to the known, in the rush of these closing days. And so you have been driven from pillar and post, poor child, footsore and half starved. Mercy, how stupid of me. Now, wait a moment; don't you move, as you hope to save the old homestead. I'll be back in a jiffy."

And back in an incredibly short jiffy he came, with a cup of tea and a plate of toast, both piping hot, to find Clara again resting in the chair back of Lewis Cass; not sleeping, indeed, but with a wistful, dreamy expression on her pretty face.

"Now, Miss Malby, we'll get along like a house afire," he said cheerily, as he urged the food upon her. "Bless you, I've had troubles of my own. Why, I was quite a Wandering Willie for a while. And now, think of it, I'm clerk of the Senate Committee on Land Claims, and Senator Ryland, the chairman, is the best sort of a father to me. That brings me right up to the point I was going to make. The senator doesn't think much of this bill to confirm the title of the Mulcimer Company to those bottom-lands. The trouble is he doesn't know anything against it. It is fair enough on its face, and so it will go through with a rush unless it strikes a hidden snag. But he has no confidence in the two men back of it, Representative Fox and Attorney Crook."

"We had no money to pay a lawyer," replied Clara, "but Mr. Drake, a friend of ours, advised me when he heard I was bound to come. He said if I only could get a trace of the papers of Meacham, the land agent, who was slain by the Indians, they would show that my father's title was perfect and complete."

"But I fear, Miss Malby, those papers were destroyed at the same time Meacham was."

"They are among the old records of the Office of the Commissioner on Indian Affairs, though no one suspects it," said Clara in those monotonous tones in which a quotation is so often uttered.

"Why, Clara—excuse me, Miss Malby—what do you mean?"

"Rather, you must pardon me, Mr. Ryland," said the girl innocently, "for still living in my dreams. I thought I heard someone say that when I was asleep."

"But what sort of a someone? You couldn't have dreamed that. You never had heard of the Indian Commissioner's Office spoken of so formally, had you?" persisted the young man, excitedly, though he couldn't keep from smiling over Clara's literal interpretation of what he had said of Senator Ryland's good influence.

"I looked all around," explained Clara. "There was nobody within speaking distance. There was nobody even in sight, except two men, passing out of the hall, way over there by the clock. Their heads were close together—they were talking earnestly and secretly, it seemed. One of them was tall and thin, with grayish chin whiskers and a loose alpaca coat. The other was stouter and younger and more stylish, with a little mustache, half bitten off you might say, and a pair of glasses on a string. Of course, it couldn't have been either."

"Of course, it was one or the other of them," declared the young man vehemently. "They were Crook and Fox—you have hit them off to a hair, doubtless bound for our committee-room which I had just locked up. Wait, wait; they may be back again presently, still talking."

"But—"

"Oh, I know, and you don't know, you see. This Statuary Hall has many queer properties. It is full of echoes. It picks up a sound, and sends it this way or that, like an arrow to the mark. It is a veritable whispering gallery. Don't breathe your little secrets, my dear. Oh, I misspoke myself, then do forgive me. But don't breathe them while you are in Statuary Hall, unless you are surely alone, for just as surely they will be overheard."

"There they come," whispered Clara, pressing his hand impulsively. "Oh, do you think—"

"Sit tight and as still as death," breathed back the young man. "It is they, Crook and Fox. See how earnestly Crook is talking, and yet how guardedly. Wasn't it he? That's right, nod 'yes.' Now, listen sharp and close—they are passing under the clock."

"I tell you it is true, Fox," came that same rasping voice. "I have it from a sure source. Those papers, with all the other stuff taken from the captured camp, were stowed away in the old warehouse on E Street, S. E., and are long since forgotten. But chance might bring them to light any day. We should decide then."

With a gesture to his companion not to move, the young man shot fleetly across the hall, confronting the two men with a dramatic gesture.

[CONCLUDED ON PAGE 26]



"The girl moved a little and half opened her eyes"

sion gave strength and beauty to his face. With the rapid steps of one who knows he hurried across Statuary Hall, to where Clara Malby was still sleeping like a tired child behind the mammoth statue of Lewis Cass.

The girl moved a little and half opened her eyes. Still in her dreams, she seemed again to see that tender, reliant gaze which once had meant confidence and happiness to her. "Oh, Harry, Harry, come to me at last, you dear," she murmured.

And then, roused by the sound of her own voice, she sprang to her feet, abashed by the handsome young stranger who faced her.

"Oh, sir, pray pardon me," she said with the old-fashioned precision she had gained from the old-fashioned folk in her old-fashioned home. "I was so weary I fell asleep, and must have been dreaming."

"Sleeping, so soundly, too," returned the young man smilingly, "that a vagabond who keeps hanging about here managed to steal your bag. Luckily I came upon him before he had time to secrete anything, and sent him off with a round turn. Here it is. Won't you please see if everything is all there?"

Clara turned over the various articles indifferently. "Yes, thank you, everything is all right," she answered. "It wouldn't have made any difference anyway."

## A Little Nonsense



**WHEN** Hiram fell into the well, he said: 'It's a good thing it's the well and not the spring, for it would be hard to die in the spring.' As it was, he died in the fall, and, as he kicked the bucket, he exclaimed: 'All is well.'

**PASSENGER**—"Which end of the car do I get off?"  
**CONDUCTOR**—"Whichever end you prefer; both ends stop."

### Where He Got It

**TEACHER**—"Now, Willie, where did you get that chewing-gum? I want the truth."

**WILLIE**—"You don't want the truth, teacher, an' I'd ruther not tell a lie."

**TEACHER**—"How dare you say I don't want the truth! Tell me at once where you got that chewing-gum."

**WILLIE**—"Under your desk."—Judge.

### Got That Far

**SHE** was very literary, and he was not. He had spent a harrowing evening discussing authors of whom he knew nothing, and their books, of which he knew less.

Presently the maiden asked archly: "Of course, you've read 'Romeo and Juliet'?"

He floundered helplessly for a moment and then, having a brilliant thought, blurted out, happily:

"I've—I've read Romeo!"—Philadelphia Times.



### Following Advice

"You should kill house-flies as you would snakes."—News-paper Advice

**MISTRESS**—"Your name, Mary, and my daughter's being the same makes matters somewhat confusing. How do you like, say, the name of Bridget?"

**COOK**—"Sure, mum, an' I'm not particular. I'm willin' to call the young lady anything ye like."

### That Eternal Question

**WILLIE**—"Pa!"

**PA**—"Yes."

**WILLIE**—"Teacher says we're here to help others."

**PA**—"Of course we are."

**WILLIE**—"Well, what are the others here for?"—Chicago News.

**TEACHER**—"Don't you realize, Willie, that by keeping you in after school I punish myself as well as you?"

**WILLIE**—"Yes, teacher. That's why I don't mind it."

### Must Stand by One Another

**MAMA**—"Johnny, I shall have to tell your father what a naughty boy you have been."

**JOHNNY**—"I reckon dad's right when he says a woman can't keep a thing to herself."—Stray Stories.

### His Own Fault

**TWO** young employees of a florist in Philadelphia, who are supposed to be variously employed in the rear of the establishment while the boss looks after things in the front, were recently startled by the appearance of the "old man" while they were engrossed in a game of checkers.

The proprietor was justly indignant. "How is it," he demanded, "that I hardly ever find you fellows at work when I come out here?"

"I know," volunteered one of the youths; "it's on account of those rubber heels you insist on wearing."—Harper's.

"**WHO** can give a sentence using the word pendulum?" asked the teacher.

Little Rachel's hand shot up.

The teacher nodded encouragingly.

"Lightning was invented by Pendulum Franklin."—Everybody's.

### That Decided Him

**THIEF** (who has snatched a lady's bag)—"Two transfers, a powder-puff, a recipe for headwash and a sample o' silk! An' I ran two miles wid it! I'm again votes fer women!"—Puck.

### Forewarned

**MISTRESS**—"When you leave, I shall want a week's warning."

**BRIDGET**—"It's me habit, mum, merely to give a blast on the auto horn."—Harper's Bazar.

### The Morning Run

**KNICKER**—"How far are you from the station?"

**SUBURBS**—"Exactly a cup of coffee and an egg, dear boy."—Puck.

### The Little Human Spool

**MAMA**—"Oh, Hubert, what shall I ever do when you are so big I can't take you on my lap and hug you any more?"

**HUBERT**—"Well, mama, I'll keep little as long as I can—but I keep unwinding all the time."—M. P. A. Crozier.

### Reasonable Restraint

**JONES**—"Is it necessary for you to send your daughter to Europe to complete her musical education?"

**BROWN**—"Yes—I can't stand the infernal racket here any longer."—Portland Oregonian.

### A Fixture

**MISTRESS**—"Are you sure you'll stay with us, Bridget?"

**COOK** (on her hundredth job)—"Faith an' I will. Don't yez suppose I know an aisy mark whin I see wan?"—Harper's Bazar.

### Love's Way

**SHE**—"I'm afraid, Tom, dear, you will find me a mine of faults."

**HE**—"Darling, it shall be the sweetest labor of my life to correct them."

**SHE** (flaring up)—"Indeed, you sha'n't!"—Boston Transcript.

### Force of Habit

"**WHY** did you break your engagement with that school-teacher?"

"If I failed to show up at her house every evening, she expected me to bring her a written excuse signed by my mother."—New York Evening Mail.

### Perplexity

"**I'M** GLAD we don't live in China," said little Oswald. "It must be awfully tiresome to have it dark all day and the sun shining at night."—Chicago News.

### Obliging

**MRS. CHINNON**—"Tell Marie I want her to come up and take my hair down."

**ROSE** (the new maid)—"Can't I take it down to her, ma'am?"—Christian Intelligencer.

### The Wonder of It

**LITTLE CLARENCE**—"Pa!"

**HIS FATHER**—"Well, my son?"

**LITTLE CLARENCE**—"I took a walk through the cemetery to-day and read the inscriptions on the tombstones."

**HIS FATHER**—"And what were your thoughts after you had done so?"

**LITTLE CLARENCE**—"Why, pa, I wondered where all the wicked people were buried."—Judge.

### Set Fair

**CLOUDY** to-day! That's what they say, The prophets of the weather.

Don't heed them, please; their prophecies - Are foolish altogether.

It's fair to-day, and fair 'twill stay  
Forever and forever;

So laugh with me, for I can see  
No trace of cloud whatever.

Jack called last night, his eyes alight—  
Now skies are blue above me.

Ah, how can they show aught of gray  
When he has sworn to love me?

If you were I, you'd know just why  
My heart is like a feather.

For Jack's a dear, and when he's near—  
Let's talk about the weather.

—L. E. Johnston, in Ainslee's.

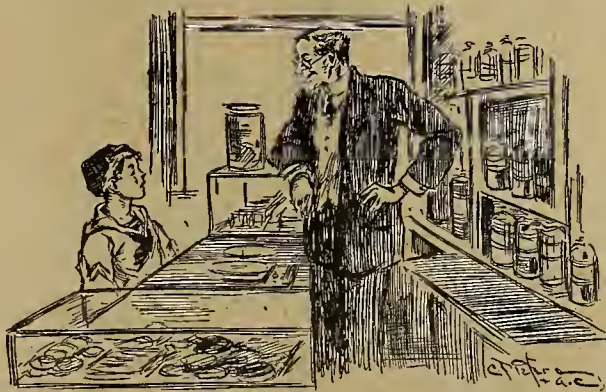

### Love's Young Dream

"Please, mister, I want two cents' worth of picture post-cards that say something nice about girls with red hair."

## The Men We Love and The Men We Marry

Are there generally two men in a woman's life—the man she loves and the man she marries?

A woman, keenly observant, and who has seen much of girls and women, holds that it is more often true than many suppose. Then she explains how it comes about: what it can mean, in suffering, to a woman, and what is the duty of a woman to be the wife of the man she married, not that of the man she wishes she had married.

A thoroughly feminine article is this. Men will not understand it, but women will.

It is in the October LADIES' HOME JOURNAL.

15 Cents Everywhere

## There Are Two Millionaires Among The Actors

One can go to bed and sleep and yet earn \$1000 a week. The other has made \$300,000 in one season.

There is also an actress who earns for herself a quarter of a million dollars in one season: who has played to over a million dollars in Chicago alone. She is the greatest money-making actress on the stage.

Another actress earns \$600,000 in a single season.

Haven't you sometimes been curious to know the weekly salary paid to such actresses as Maude Adams, Ethel Barrymore, Julia Marlowe, Annie Russell, Billie Burke, and what they earn besides.

It is now all told—and from authoritative figures—in one article, "What The Actors Really Earn," and the profits and salaries are truly amazing.

In the October LADIES' HOME JOURNAL.

15 Cents Everywhere

# "The Buttermilk Boy"

## A Tender and Unusual Love Story

By Elizabeth L. Gilbert



UP THE long hill climbed the muddy road. It had crossed the creek before reaching the steep hillside, and seemed loath to hurry out of sight. From the barn-yard gate, Bobby could see it reappear over by the big sycamore-tree; but before reaching that place it had wound around three hills, each steeper than the one just beyond the creek. Bobby turned back to the serious business of harnessing old Belle to the rattling spring wagon. He was only eight years old, and a little chap for his age, so some of the straps and buckles were hard to reach. And somehow this morning he was in no greater hurry than the easy-going road. For this was the very last time he would climb over the wheel, slap the lines on Belle's broad sorrel back and rattle proudly on the long lane.

He had been doing it ever since he could remember, only always till this summer father had helped him off. When he thought back just as far as he could, it was father who did the driving. The choke in his throat kept getting worse, but it would never do for mother to know how he felt, so he began to whistle bravely as he drove up to the milk-house door.

Mother was tall and slender. Her soft hair was getting gray, and her brown eyes were full of deep shadows that Bobby knew did not belong there. But her voice was still brave and her smile sweet as she spoke to her little son.

"You are to deliver the milk just like common, Bobby. The bottles of buttermilk are in the box, and when you have left them, you are to drive down to the blacksmith shop and hitch old Belle there. Mr. Whitten has bought her, and the wagon, and these big empty cans. Then you are to go to Aunty Jackson's and wait for me."

"The goods have been taken to the station, and Uncle John will soon come for Clover. Poor thing; she is lonesome since all the other cows are gone."

"I will be at Aunty's before dinner-time, but we don't start till four o'clock." Then her low voice faltered, and Abigail Moore held Bobby close as she whispered, "Oh, it is so hard to leave it all. Oh, Bobby, how can we do without father!"

The small face nestled close in mother's neck, and all the strange sorrow of that long summer seemed to settle around them in a black cloud. Happiness, so long theirs, had gone, and the burdens of life seemed too heavy for their frail hands to carry. But when Bobby's face, so like father's own, was lifted, he put both little hands in mother's as he sobbed, "Don't feel all by yourself, mother; I told father I'd keep care of you."

Blindly he climbed back into the wagon, and drove slowly past the house and out the willow-shaded lane.

Mother, watching him as she stood on the doorstep, saw him stop at that last turn of the road by the sycamore-tree, and knew he was saying good-by to the home where all his days had been spent.

As she turned to go into the house, she saw his name, laboriously carved deep into the end of the step. It was newly done; a mute appeal to inanimate things not to forget him.

And Bobby? As he looked back down the valley and saw the hills that circled it, rising one above another, each touched with the morning light, each one a part of all his life, he seemed to hear father's voice again. And again to be standing on the highest hill of all, as he had one evening last spring, with father saying, "This is where I learned to say, 'I will lift up mine eyes unto the hills, from whence cometh my help.'"

With a long sigh, he started on. Over on the next slope, where the pine-trees murmured, father lay asleep, but somehow Bobby's heart felt very near to father now. Slowly he drove past the gleaming white stones and down into the last valley before the town began. It was a quaint old town, beginning at the hill's foot and wandering aimlessly up its one long street.

Bobby often wondered where all the people were who lived in the old brick houses, for there never seemed to be anyone in sight. The sidewalks, made of irregular blocks of flagstone, far apart, always were a temptation to the little boy. And sometimes old Belle was left to her own devices, while he skipped from stone to stone, imagining himself Eliza crossing the Ohio on floating cakes of ice.

To-day, as he went from house to house, everyone had a kind good-by for the little "buttermilk boy."

At last he was done.

Old Belle turned a wondering eye on her small-master as he left her behind.

It seemed impossible to go to Aunty Jackson's with such a lump in his throat and such an ache in his heart.

Always Bobby had been consumed with curiosity about an old stone house at the very end of the town. Always, since he could remember, it had stood with its shutters closed and its high iron gate locked.

To go clear away to Uncle Ned's ranch in Kansas without knowing what was inside that walled garden was too much for even a sad little boy to think of calmly.

It was a long time till noon, and if he went to Aunty's house, he would have to sit so still in the big parlor, where all the chairs had gray covers over them. And if he ventured into the steep back yard, Aunt Jane and Aunt Debbie would both tell him not to fall into the cistern, nor out of the plum-tree, and not to catch Augustus, the cat.

In spite of the call of duty, the sturdy little feet skipped from one stone to another up the long, silent street, and at last he stood before the big iron gate.

Timidly he lifted the latch. He had tried it once when father was along, now it moved, and the gate creakingly swung wide open.

Down the path his eager feet carried him. It was a winding path, with old-fashioned flower-beds on each side, neglected and full of weeds; but bravely holding their own, sweet-william and larkspur, June pinks and bachelor's button still rioted out to the path. Old gnarled apple-trees were there, and ivy clung to the gray stone wall. No sounds of life came into this enchanted spot, and the boy walked softly and with wonder in his heart.

The summer rains had made the grass as soft and green as springtime, and as the path alluringly turned a corner, great masses of white lilies came into sight. Against the wall they pressed, stately ranks of them sprang up beside the path and clumps of them clustered close to an old summer-house.

Their heavy fragrance filled the air, and as Bobby paused to inhale it his eyes wandered to the biggest apple-tree of all.

Wonder of wonders! A swing hung from its spreading branches, and there on the grass, not far away, lay a rag doll. On he ran, only to find the path ending in a tiny brook that sang merrily across that corner of the garden.

Bending over the water was a little girl, a fat, blue-eyed baby girl, so intent on her bark boats that she had not heard his footsteps. He paused, for here was the garden fairy.

Softly he crossed the grass and knelt beside the brook, and when the other child saw the reflection of two faces where only one had been, she clapped her fat hands in glee. "Is you big bruver, comed out of the sky to play wif Polly?" she asked.

"No, I'm just the 'buttermilk boy.' Have you always lived here in the lilies till I found you?"

"I've Polly Sunshine, comed here to live wif my grand-faver, 'cause all my family's gone up to heaven, an' I comed out to the flowers and birdies and water, a-waitin' here to play wif me, and looked in the water, an' there you was," said the baby all in one rapid sentence.

Bobby had never been to school, nor played with little children, and to the old-fashioned little fellow this roly-poly angel gave a wonderful day.

Time was forgotten, and his fairy stories thrilled her heart, his whittled boats were hailed as wonders, and the play-house he made in the sycamore's roots was a joy for days to come.

All that golden morning they played among the lilies, with no question of name nor ancestry. And when the sun cast its shadow on the noon mark, an old colored woman came down the walk to hunt Miss Polly.

Then Bobby knew that he was still on earth, for Mammy Sophy had been his refuge oftentimes in long visits at Aunty Jackson's.

"How on airth did you-all git in year, buttermilk boy, an' Miss Debbie a-lookin' all de forenoon for you to set on dat slick sofy ob hern?" she said as she laid a gentle hand on his brown hair.

"I don't have to go to Aunt Debbie's till nearer train-time, Mammy Sophy—and it's—my—very—last day—to be a little boy—and—" His voice faltered more and more, as the dread of the unknown again came over him.

Then Mammy Sophy gathered him onto her bosom, as she had many times before. "You'll git yore day, all dar is left ob it, honey-chile. Jes' stay here wif my white lamb and hab yo' lunch, and I'll go tell yo' ma whar you'se at."

So the two children sat down at the little round table in the summer-house, and, as they ate, Bobby told Polly all his troubles, and that by and by he would come back for her and carry her with him to the land where now he must go with mother.

Before he was through, Polly's yellow head drooped wofully, and at last he found that she was sound asleep. So he lifted her into her hammock, and sat in the swing under the big apple-tree till mother came.

Then he and mother kissed the garden fairy, and went back through the iron gate into the land of reality.

On toward the west hastened the wide, straight road; it had no time for crook nor turn, for the great wheat-fields came crowding to its very edge. Not a breath of air stirred; the hot sun poured unfaltering heat upon the road's far-reaching way and clouds of dust hung close above it.

Creaking, one after another, for days the heavy-laden wheat-wagons had gone this way. On the quivering air came the hum of thrashing-machine, or the engine's shrill call to action.

Of all the farms along this road, none was more prosperous than one from which the last loads of wheat had just gone. At the barn-yard gate, Robert Moore stood and watched the lazy dust-clouds that crawled just above his wagons; then, turning abruptly, he hurried across the yard and into the house.

Here he found his mother, and as the sunshine fell across her face it showed that long, hard years had made deep lines there; had made her hair white and bowed her slender shoulders before "Bobby" helped the easy years to come.

His eyes filled with tears, but his voice was full of happiness as he took her thin hand in his.

"Well, little partner," he said, "we are through just in time, and the biggest crop of all. Can't I persuade you to go with me to-night, when I start east for Mary? I hate to leave you here. Uncle Ned can get along alone, and I want you."

"Now, Robert, I have never said no very often, but I must this time. It is hard to put in words, but I *couldn't* go back the way we came twenty years ago. And to go back to Pleasant Hill, where father came to marry me, and where he left me with just you to 'keep care' of me. No, my boy, I can't. I'll get everything ready for Mary, and I'll think of you all the time as I work. That will be best."

Her heart was very full as she looked out over the fields that had yielded their golden harvest, at the cattle grazing in the broad pastures, and at the great trees that she and her little, little helper had set out when they took up their claim.

"We have gone through the hard days together, Robert. Now, we must learn to face happiness, too."

Then she helped him get ready for his journey, and as Robert looked from the car window that evening at her solitary little figure outlined against the sky the greatness of human love, the depth of human sorrow seemed typified in her. At his side seemed to be the timid little boy whom the twenty years and mother, with God's help, had changed into a reliant, prosperous man.

He relived all their years together as the train rushed through the night. Mother-love and wife-love, both soon to be his.

How strange that in his university days no face had stirred his heart, and then six months ago Mary Boyd came into his life to fill it full.

Mother had smiled at him when he came home and told of Mrs. Allen's niece from Ohio; then she brooded tenderly over his romance, and finally had fallen in love with Mary, too.

All the time he felt that somewhere he and Mary had belonged to each other, so the month between their meeting and their engagement seemed long to him.

And Mary, shy and modest in her love affair, had sternly said he must wait six months, for she never expected to tell grandfather she had said "Yes" so soon.

As it was, grandfather had refused to speak of Robert except as "The Kansas Cyclone," but his devotion to Mary perhaps accounted for that. She had gone home to get ready, while, for once, time seemed to stand still in Kansas.

Only when he began to question her as to where his letters should go did Robert realize that Pleasant Hill was to be the scene of another chapter of his life. And now he closed his eyes and built the old town up from memory. The hard years in the West seemed like a dream, childhood became a reality, and especially that wonderful last day of all, when he and his fairy dwelt in the garden.

Mother had never found out who the little girl was, but her face had always had the center of his heart till Mary came. Somehow, she seemed to grow up as he did, and even now she was almost as dear to him as the wife he was to find among the hills of his childhood.

Gradually the long stretches of level country changed to hills, and at last the woods and streams of long ago encircled him.

He had not known just when he would reach Pleasant Hill, so no one met him. He looked around involuntarily for the one bus and old black Sam who used to drive it. Instead, a row of shining cabs met his gaze. The stepping-stone pavements were gone, street-cars whizzed here and there on the many streets grown from the one he knew.

As he gave the number to the driver and got into the cab, he looked out over the hills purpling with evening light, and felt that he had come home. On up the original street they went, and Robert almost heard the milk-cans rattle as they bumped over a car-track.

And when the top of the hill was reached, the cab stopped and like one in a dream he got out. For they had gone through an iron gate, and beyond the old stone house lay a walled garden. A little old man bounced out of the house and down the steps. "Bless my soul, a Kansas cyclone and nobody to meet it but me! Well! Well! Well! as long as I've found out at last whose grandson you are, I'll give my consent to that wedding-to-morrow. Mary is in the garden. Go bring her in." And he went in as rapidly as he had come out.

So once more Robert walked between beds of flowers, past gnarled apple-trees and close to ranks of stately summer lilies, and the moon looked down over ivy-covered walls of stone.

Just beyond the turn of the path, where the brook came singing across the garden, he found her. Once more he looked into the brook, and the moon hid her face a moment, for there was only *one* shadow now where two had been.

For by winding paths and all unknowingly, Polly Sunshine and the buttermilk boy had once more found the Garden of Eden.

**The Wages of Sin**—Bert Somers, a lively four-year-old, is a great pet of the young lady next door, and spends a good deal of his time with her. One morning he had not made his usual early call; and Miss Sallie went in by the back way, just before noon, to learn the reason. There was no one about, so she called:

"Bert, Bert, where are you?"

"Here," answered a shrill voice from up-stairs, and Miss Sallie, ascending, found her young friend, nightie on, in bed.

"My, my!" she exclaimed, "what are you doing in bed, this time o' day? In for a nap?"

"Naw! In fer sassin'!"—Juliette M. Babbitt.

**Fore!**—JONES: "Do you think the horse will survive the automobile?"

**Brown!** "Not if it gets in its way."—L. B. Corley.

# A New Laundry Method

By J. G. Allshouse

**T**O ALL intelligent, thrifty and ambitious housewives who value the highest degree of elegance in their laundering, especially when this is attended by a great saving in time, money and hard work, the value of the process here given can scarcely be measured in dollars and cents. Although heretofore kept a trade secret, it has been given years of thorough test and effectually proved its superiority over all marketed preparations and commonly known methods of laundering. It is now, for the first time, made public by the writer, who offers it as a boon to the busy woman who appreciates pleasing results and beautiful finish as well as economy and ease in her work.

The easily made preparation described keeps indefinitely, and may be used over and over until it is completely gone; a few cents' worth goes farther than several pounds of ordinary starch. It yields satisfying results which are much better than other starches give. It is adapted alike to the most simple and the very finest laundering; is always ready for use, no boiling, warming or other delay and both, and no waste, no matter how small or large the wash. The articles to be laundered may be starched in a moment, either before or after drying, and then ironed and polished immediately or left until a time more convenient; and whenever you iron them they will finish up with a rustle and polish never known under the old method. The method is quick, simple, economical, absolutely convenient and more efficient in every way.



Take one-quarter pound of ordinary lump-starch, four teaspoonfuls of powdered borax, two tablespoonfuls of turpentine, one tablespoonful of glycerine and three quarts of pure, soft water. First dissolve the borax in the water, then rub the starch into a smooth paste with a little of the borax water, adding the rest of the water a little at a time, until all is added. Then mix in the turpentine and glycerine, and shake or stir up well together. Keep in a stone jar or earthen vessel with a good wide mouth, covering the top with muslin or cheese-cloth to keep out the dust. Stir up well before using, and strain what is wanted for use through a piece of cheese-cloth to insure freedom from any lumps. A few drops of bluing may be added when mixing, if desired. Larger or smaller quantities may be mixed in the same proportions.

After stirring up the preparation, pour off enough into a bowl or any suitable vessel to wet the articles to be laundered. Dip the articles into the solution, do not wring very dry, but roll up tightly, and leave but a few moments, when they will be ready for the irons.

Shirt bosoms, collars and cuffs will be stiffer if the liquid is whipped into them. Take them between the hands, and with a quick, snapping movement, beat folds of the linen together. This method tends to dry away a portion of the moisture, and a second dipping into the liquid, attended by a second beating, proves advantageous.



With a soft, white cloth, wrung from very warm water, rub briskly and thoroughly the entire surface to be ironed and polished. This removes all starch that may be on the surface of the linen, and although the preparation never sticks to the iron, the polishing will be smoother and glossier for this additional care. When perfectly dried, if dampened over with a cloth wrung from warm water and again polished over with a not too hot iron, the result also will compensate for the extra exertion and time.

Shirt-waists, skirts, collars, cuffs, in fact almost any article of fine or simple nature, may be starched before or after the drying that follows the washing. Roll tightly by themselves or in a dry cloth, and iron within ten or fifteen minutes, or allow them to lie half an hour or longer before ironing, just as convenient.

Experience teaches the careful housewife best methods in all branches of her work. She prefers not to follow set rules apparently contrary to her own successful experience, but favors the method that individually gives her the greatest degree of satisfaction. We, therefore, expect the person doing the laundering to adapt these instructions, in the main, to her own way of doing things, so far as she finds it advisable to do so.



Collars and cuffs may be starched directly after they come from the wringer, or, if in no hurry, they may be hung up to dry and starched whenever you are ready. When starching, follow the general directions. If you want the articles

extra stiff, repeat the dipping and beating process several times until the linen has absorbed all the liquid you wish. As a rule, best results follow if you iron and polish within ten minutes after starching.

White or colored dress shirts may be starched before or after drying, but for best polish better let them dry before starching. Starch shirt bosoms on both right and wrong side, beating the liquid in well as advised above for collars and cuffs in the general directions. Wring dry, fold or roll up and then iron or polish after ten or fifteen minutes or within a shorter or after a longer time if you wish.



After ironing with ordinary flatiron, till the linen is nearly or perfectly dried, lay the article upon a hard, smooth surface. The ironing-board, a table or any even-surface board will answer. Use no covering, or else a very thin, clean cloth. Moisten the linen with a clean, damp cloth, not too wet. If you have no regular polishing-iron, use an ordinary flatiron for polishing. Rub the edge or point of flatiron crosswise of the article you are polishing, exerting considerable pressure and friction until a fine, uniform polish is produced. Do not use the face of iron, but the "heel" or edge, and always rub across the fabric instead of lengthwise. With a regular polishing-iron, the correct compact weight and the rounded edges make the polishing a simple matter. Have the iron clean and very hot. The use of this liquid preparation, an iron properly adapted to the work and a little attention to these directions are the whole secret of your producing a perfect and attractive, superb gloss or enamel that will equal and very often surpass the efforts of the professional launderer.

After shirts, collars and cuffs have been ironed and polished, if you wish to have them perfect as when new, press the sharp edge of iron all along upon the stitching of the linen. All linen must be washed perfectly clean before the laundering if best results be expected. The irons also must be kept clean by burnishing the sides and bottoms with fine emery-paper or cleaning with common salt, and must not be set on a dirty holder at any time. Proper waxing of the iron is essential. If you have no other waxing-device, use the best quality of beeswax expressly prepared for laundry use; put in a cloth and rub on the surface of the iron before ironing.



For the best grade of shirt-front work, collars, cuffs and all articles improved by a fine, gloss enamel, a laundry or polishing iron, nickel-plated, with rounded corners and weighing not less than five pounds, is necessary. An iron of this kind should be owned by every housekeeper; the cost is small and it will pay for itself many times over in the satisfaction of seeing work from your hands that otherwise only a professional could produce.

The inexpensiveness, the avoidance of delay and trouble and the superior results attained make this laundering process one of the greatest conveniences ever offered the busy woman; and after trying it a time or two, she will never return to the old-fashioned method.

\* \* \*

## Laundry Notes

Tea and Coffee Stains—Pour boiling water from a height upon the article spread over a bowl.

Chocolate or Cocoa Stains—Sprinkle the stain with borax. Soak in cold water, then pour on boiling water.

Milk or Cream Stains—Wash while fresh in cold water.

Fruit Stains—One-half cupful javelle water to one gallon of boiling water. Wash, then rinse well.

Meat-Grease Stains—Wash in cold water, then with good laundry-soap.

Grease Stains on Delicate Silk or Woolen Materials—Lay cotton or wool beneath the fabric, and remove the stain by wetting the spot with sulphurous ether. Work quickly, as the ether evaporates rapidly.

Grease on Wash Goods—Cover the spot with lard, let stand thirty minutes; remove, soak in cold water, without soap, then in hot water.

Sewing-Machine Oil Stains—Wash in cold water and white soap.

Grass Stains—Wash with alcohol. Soak in strong cream-of-tartar water, then wash as usual.

Mud Stains—When dry, remove with a stiff brush. If the spot remains, sponge with strong alcohol.

Medicine Stains—Soak in alcohol.

Iodine Stains—Wash with ether or chloroform. Wash with alcohol, rinse in soapy water, or cover with a paste of saleratus and water; afterward wash as usual and the stains will disappear.

## Fall Fashions are Very Beautiful

"The prettiest in years," "the most becoming fashions in a generation," "so very, very new"—this is the story of the fascinating, charming styles for Fall.

Never have you seen more becoming garments than the new "NATIONAL" coats, never were designed more grace-giving, fascinating dresses and waists than your "NATIONAL" Style Book shows.

And of hats Paris has sent us designs of unusual beauty.

Therefore, to know all these new styles, to see what is to be worn in New York, this alone is sufficient reason why you should, right now, send for your own free copy of the "NATIONAL" Style Book.

But add to all this interest in the new and beautiful styles, add to this delight, the saving "NATIONAL" prices offer, and it becomes a matter of your own great personal advantage that you send for your Style Book pictured above.

Just say, Send me My "NATIONAL" Style Book Free. It will be sent you gladly by return mail.

### Your "NATIONAL" Style Book Shows:

Dresses . . . \$10 to \$30	Hats . . . \$2.98 to \$15
Coats . . . 10 to 50	Skirts . . . 3.98 to 15
Furs . . . 2.25 to 75	Waists . . . .98 to 10

Also a full line of Underwear, Hosiery, Scarfs, Veils, Raincoats, Gloves, Sweaters, Leather Goods, Jewelry and a complete line of Boys', Misses' and Children's Wearing Apparel.

## "NATIONAL" Tailored Suits

Made to Measure \$15 to \$40

### Samples of Materials Sent Free

Each Made-to-Measure Suit is actually cut and made to order, and we guarantee each suit to fit perfectly and to be satisfactory in every way, or we will cheerfully refund your money.

### The "NATIONAL" POLICY

We prepay postage and express charges on all our goods to any part of the world. You may return any "NATIONAL" garment not satisfactory to you and we will refund your money and pay express charges both ways.

In writing for your Style Book, be sure to state whether you desire samples of materials used for "NATIONAL" Made-to-Measure Tailored Suits. Samples are sent gladly, but only when asked for—and they are well worth asking for.

**NATIONAL CLOAK & SUIT COMPANY**  
283 West 24th Street, New York City

Mail Orders Only

No Agents or Branches

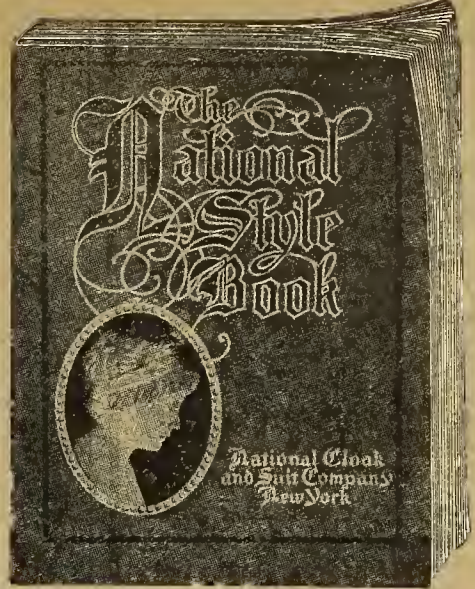

Copyright, 1911, by National Cloak & Suit Co.

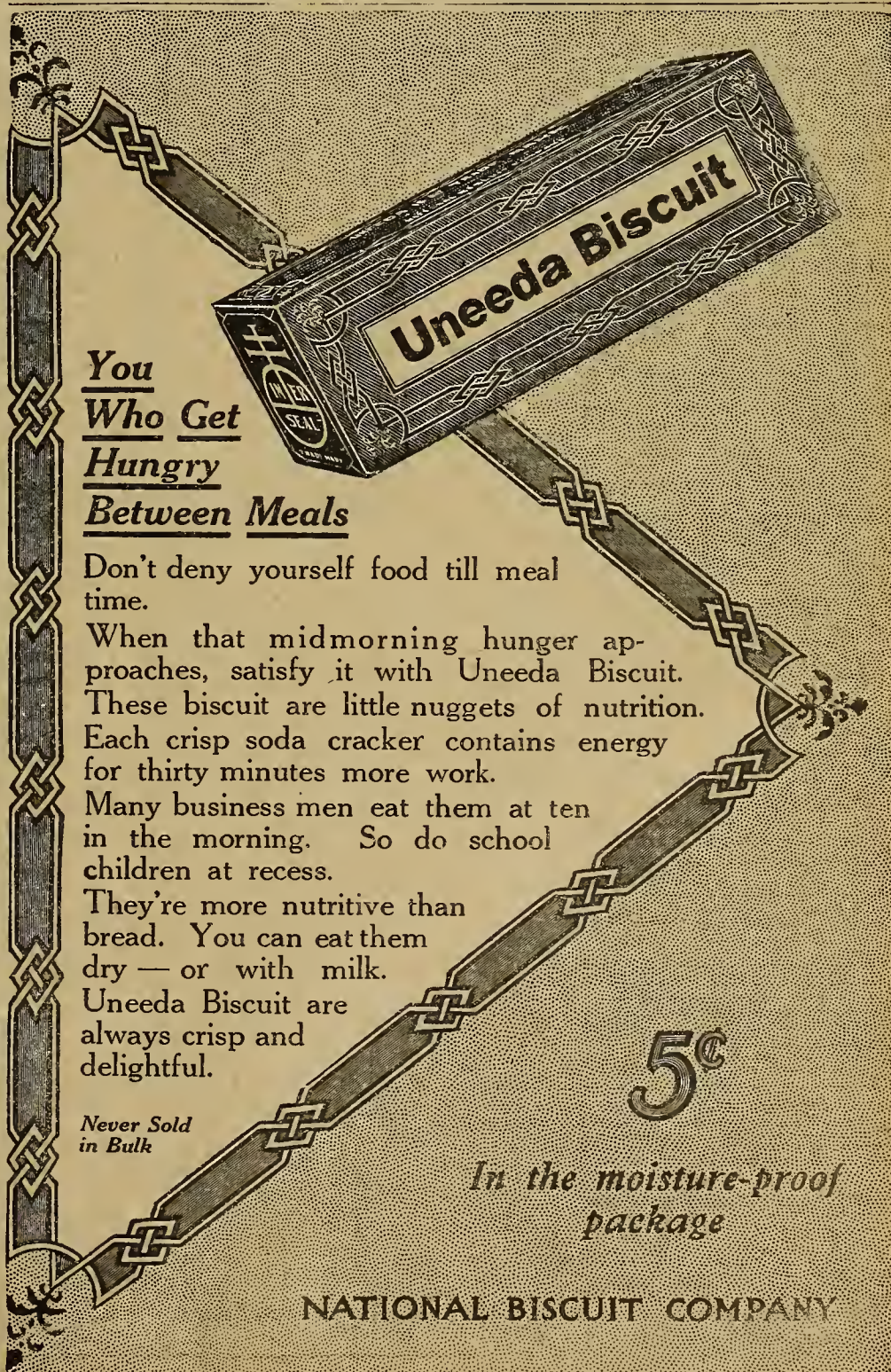

**You Who Get Hungry Between Meals**

Don't deny yourself food till meal time.

When that midmorning hunger approaches, satisfy it with Uneeda Biscuit. These biscuit are little nuggets of nutrition. Each crisp soda cracker contains energy for thirty minutes more work.

Many business men eat them at ten in the morning. So do school children at recess.

They're more nutritive than bread. You can eat them dry — or with milk.

Uneeda Biscuit are always crisp and delightful.

**5c**

Never Sold in Bulk

In the moisture-proof package

**NATIONAL BISCUIT COMPANY**



# Fashions Which Will Make The Very Latest Telling Features

Designs by Grace Margaret Gould



**Don't Use Laundry Soap on Your Face**

**JAP ROSE**  
"The Bubble Bath Soap"

is unequalled for cleansing your skin because it is the original, transparent Toilet and Bath Soap and is absolutely pure. Because it is made of vegetable oils, it cleanses instantly, thoroughly and refreshingly. For genuine pleasure and satisfaction insist on getting

**JAP ROSE**  
Sold by dealers everywhere

**REFUSE IMITATIONS**  
Look for the Jap Girl on every package.

**A Large Cake for 10c**



**No. 1842—Peasant Blouse with Guimpe**  
Cut for 32, 34, 36, 38 and 40 inch bust. Material for 36-inch bust, one and one-fourth yards of thirty-six-inch material, with one yard of embroidery, five eighths of a yard of velvet, two and one-half yards of tuckings, twenty-four inches wide, for the guimpe

**O**F COURSE, few women follow fashion exactly when they are planning their clothes, but there are few women, indeed, who do not want to know what the telling features of the new fashions are. Such things as the width of the skirt, the position of the waist-line and the shape of the sleeves are all important considerations for the woman planning her new clothes, or remodeling those of last season.

The narrow skirt is still favored, though it is a bit wider than it has been. It now measures from two and one-half to three yards round. The plain skirt is fashionable and so is the model with a plait back and front, or a few plaits let in at the sides, and there are many skirts with tunics. The waist-line is very obliging this season, so if a woman looks better having her waist where nature intended it to be, she can have her skirt made with a normal waist-line and feel that she is quite fashionable. If, on the other hand, her figure is such that raising the waist-line gives her a more youthful appearance, you can go her waist two inches or more, if she wishes.

surely a hint of what may be coming. For shirt-waists and tailored coats, a straight coat sleeve set into the armhole will be used this fall. The sleeve for the costume waists and the dressy costumes will show the three-quarter length. For some time long sleeves have been clamoring for recognition in the fashion world, and at last Dame Fashion has heard their plea. Many of the newest fall waists are made with long sleeves, the bottom finished with a frill of dainty narrow lace. This bit of fashion news will be welcomed by the woman who is self-conscious about her arms, which, perhaps, are either too fat or too thin. Both old and new laces are being used in the most interesting of ways in the fall fashions. Among the lace novelties is the beautiful Spanish lace dyed to match the fabric of the gown.

The acme of perfection seems to have been reached in the new autumn fabrics. The wool materials, such as the chevots, the serges, the Scotch mixtures and the worsteds show color touches which are novel and most fascinating and most artistic in their designs. Each season, however, there are a few materials which are looked upon as Fashion's special favorites. In silks, it is taffeta that is carrying off all the honors. It is not new, to be sure, but it has certainly made satin take a back seat. The fashionable taffeta for fall and winter is exquisitely soft in its weave and has a high, beautiful luster. It is wider than it used to be, which is another good point in its favor.

It is not only old-time fabrics and old-time designs, but old-time trimmings that are meeting with favor. Fringe is the vogue. Worsteds embroideries in the gayest of colors give the brilliant note to suits and wraps. Beads are used in innumerable sizes, woven on net in the most fanciful of designs.



**No. 1830—Long Coat with Large Armholes**  
Cut for 12, 14, 16 and 18 year sizes. Material required for medium size, or 14 years, five yards of thirty-six-inch material, with one-half yard of a contrasting material for the trimming

**No. 1832—Long Coat with Belted Back**  
Pattern cut for 4, 6, 8, 10 and 12 years. Material required for 8 years, three and one-fourth yards of forty-four-inch material

**No. 1834—Sailor Suit with Kimono Sleeves**  
Pattern cut for 4, 6, 8, 10 and 12 years. Quantity of material for 8 years, three yards of thirty-six-inch material, with one-half yard of contrasting material for the trimming, and one and one-fourth yards of thirty-six-inch material for the guimpe

# Your Wardrobe Up to Date of the New Fall and Winter Styles

Drawings by Lewis Elberon Bailey

**T**HIS is the time of year when everyone is thinking about how to make her new fall and winter clothes, and how to remodel those of last season so they will be up to date in style. Illustrated on these pages are some of the best of the new designs. Though fashionable, they are also practical. They can be easily made too, which is always a consideration when time is limited.

For those who wear no two designs could be prettier than those shown in patterns Nos. 1867 and 1701. Both these dresses are made with high waists and are cut low in the neck, which makes them especially comfortable if one needs to do housework. They both fasten in front, enabling them to be slipped on and off in a very short time. In fact, they are excellent substitutes for the wrapper, which seldom makes a triumphant gown.

The two afternoon dresses shown in patterns Nos. 1872 and 1873 and Nos. 1857 and 1858 are very attractive, though they are simple. The dress pattern Nos. 1872 and 1873 has a regular skirt. It should be trimmed with a band of the same material that trims the waist. The waist is made with the sleeves fitted into the normal armholes. It has a short basque which is seen in a number of the new models this fall. The pattern also provides for the underhoop. This dress would be effective made of taffeta silk, a light-weight cloth or cashmere. The other dress pattern Nos. 1857 and 1858 would look its best made of voile, marseilles or one of the pretty soft crepes. The skirt has a panel back and front with side tunics. The waist is in surplice style with the sleeves fitted into the armholes. There is an underhoop which should be of net or all-over lace.

Appropriate clothes are very necessary for the young daughter beginning her first term at high school in the neighboring town or even going to school in her own village. Shown in pattern No. 1830 is an excellent coat for winter wear, for no matter how bad the weather it will protect the dress worn underneath it. It is an easy model for the home dressmaker to fit and make. Make of rough cloth or cheviot, and trimmed with plain cloth, it would do not only for school, but for every other occasion. It is a good-style coat.

A good dress to wear with this coat is shown in pattern Nos. 1713 and 1714. For school this dress may be made very plain, while for Sundays or more dressy occasions one of the pretty jabots or wide side frills of net or lace may be added. Besides these designs there are illustrated on these pages clothes for the little girl and boy, as well as two designs for waist, a shirt-waist and a costume blouse for mother or grown-up sister. For every design illustrated we supply a ten-cent paper pattern that is accurate in cut and easy to use.

To the woman who is just learning to sew, the art of putting a paper pattern together seems almost as difficult a feat as solving a Chinese puzzle. But the puzzle will be solved once she has tried one of our splendid, practical and up-to-date WOMAN'S HOME COMPANION patterns. Dress-making will then be a very easy matter, for each piece of the pattern is so plainly lettered and the directions on the pattern envelope so complete and explicit, that it is impossible for even a child to mistake one part for another.

**No. 1701—Empire Wrapper**  
Cut for 32, 34, 36, 38 and 40 inch bust measures. Material required for medium size, or 36-inch bust, three and one-half yards of twenty-four-inch material, or six yards of thirty-six-inch material, with one half of a yard of contrasting material

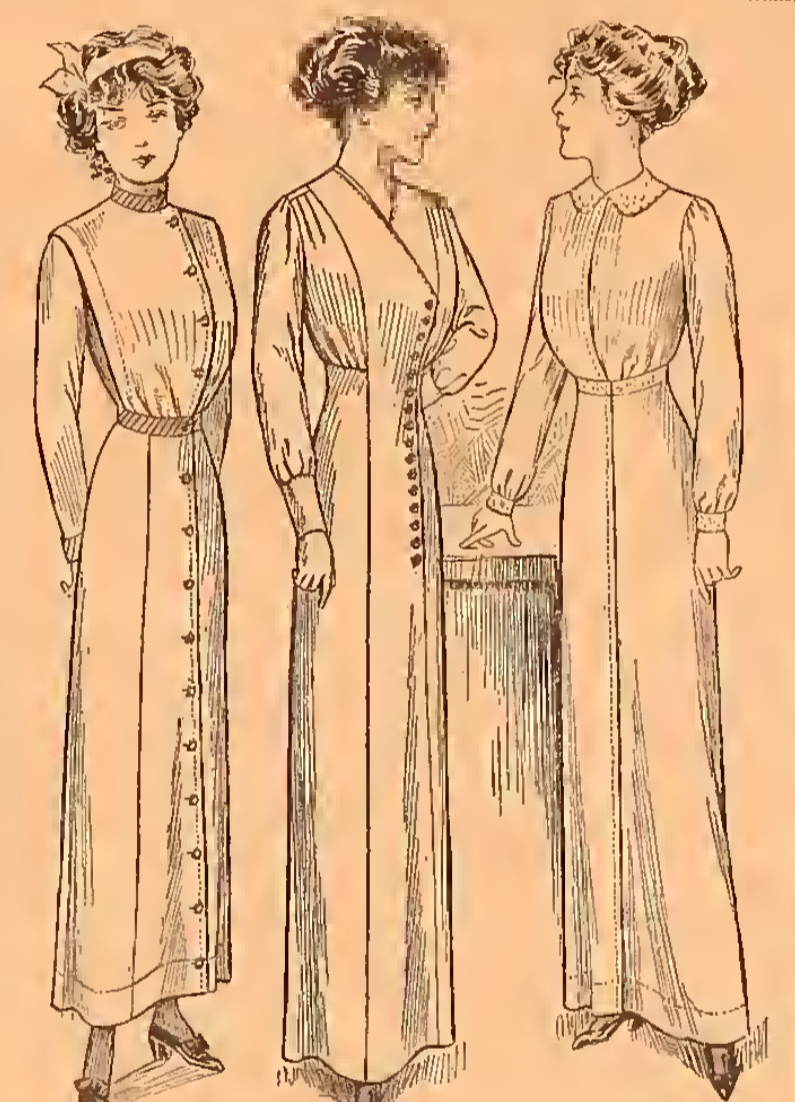

**No. 1713—Misses' Double-Breasted Waist**  
Pattern cut for 12, 14 and 16 year sizes. Quantity of material required for medium size, or 14 years, two and one-fourth yards of twenty-four-inch material, or one and seven-eighths yards of thirty-six-inch material, with one-half yard of a contrasting material

**No. 1714—Misses' Gored Skirt Buttoned at Side**  
Pattern cut for 12, 14 and 16 year sizes. Quantity of material for medium size, or 14 years, five yards of twenty-four-inch material, or two and five-eighths yards of thirty-six-inch material

**No. 1867—Semi-Princesse Dress, Empire Effect**  
Pattern cut for 32, 34, 36, 38 and 40 inch bust measures. Quantity of material required for medium size, or 36-inch bust, seven and one-half yards of twenty-four-inch material, with one and one-half yards of contrasting material thirty-six inches wide for the waist portion



**No. 1872—Waist with Peplum**  
Cut for 32, 34, 36, 38 and 40 inch bust. Material for 36-inch bust, two and one-fourth yards of thirty-six-inch material, with one and three-fourths yards of forty-four-inch material for guimpe

**No. 1873—Plain Circular Walking Skirt**  
Cut for 22, 24, 26, 28 and 30 waist. Material for 26 waist, four yards of thirty-six-inch material

**No. 1857—Surplice Waist with Double Sleeves**  
Cut for 34, 36, 38, 40 and 42 inch bust. Quantity of material required for 36-inch bust, one and five-eighths yards of thirty-six-inch material, with one and three-fourths yards of tuckings

**Woman's Home Companion Patterns**

If you want to make your clothes without any trouble, you should buy the WOMAN'S HOME COMPANION patterns. They are the sort of patterns that the busy woman needs, for they are so accurately cut and graded that the garments made from them can be easily and quickly put together. They cost but ten cents apiece and may be ordered from the nearest of the three following pattern-depots: FARM AND FIRESIDE, 381 Fourth Avenue, New York; Springfield, Ohio, or 1538 California Street, Denver, Colorado.

**A Premium Offer**

To any FARM AND FIRESIDE reader who sends us one new subscription to FARM AND FIRESIDE, with fifty cents for the same, we will give as a premium for the subscription one WOMAN'S HOME COMPANION pattern. To obtain one of our splendid patterns without cost to you, send the subscription to FARM AND FIRESIDE, Springfield, Ohio.

**The New Fall Catalogue**

HAVE you seen it, the new fall catalogue of WOMAN'S HOME COMPANION patterns, which is just out? It is full of just such helpful clothes suggestions as every woman needs. There are designs for street costumes, for house gowns, for big daughter and little daughter, and even the small boy of the family has not been forgotten. Before deciding on your fall clothes, or your children's, you should study this splendid and complete guide to correct dressing. It will help you more than you realize, and with practical, helpful and sensible suggestions. It costs only four cents. Send for it to-day. It may be ordered from the nearest of our three pattern-depots: FARM AND FIRESIDE, 381 Fourth Avenue, New York (for eastern readers); Springfield, Ohio (for readers in the central section); or 1538 California Street, Denver, Colorado (for western readers). Now that we have three depots, it is possible for any woman, no matter where she lives, to receive her patterns without delay.



**No. 1837**  
**No. 1836**  
**No. 1747**  
**No. 1713**  
**No. 1867**  
**No. 1701**

# It's Baker's and It's Delicious



Made by a perfect mechanical process from high grade cocoa beans, scientifically blended, it is of the finest quality, full strength and absolutely pure and healthful.

Sold in 1/5 lb., 1/4 lb., 1/2 lb. and 1 lb. cans, net weight.

Booklet of Choice Recipes Sent Free

**Walter Baker & Co. Ltd.**  
Established 1780 Dorchester, Mass.

Test an **IMPERIAL** 30 Your Own Home at OUR RISK

Thousands now in use!  
Demand growing amazingly!  
Four years in the field!  
The real surprise ever (themselves)

Has EXCLUSIVE FEAT-  
URES such as: Oiler Hood—  
Carries all steam and  
cooking odors to chim-  
ney. Ash Sifter—Permits  
sifting ashes right in range.  
Oven Thermometer—Shows Oven  
Bottom—Absorbs and holds  
heat in even a hot oven.  
Direct from factory to you! Wholesale Price, Freight  
Prepaid. Easy Credit Terms if wanted.

365 DAYS' GUARANTEE!

Write Today for Free Catalog and Special Prices.  
**THE IMPERIAL STEEL RANGE COMPANY**  
168 State Street, Cleveland, Ohio

**PLAYS FREE JOKES**  
FREE CATALOG OF JOKES,  
Puzzles, Riddles, Gags, Trivia  
for Mental Sharpening. All kinds of  
toys and puzzles. Latest Songs  
Send today, WILL ROSSITER, 130 W. Lake St., Chicago

**Take Your Choice of these 32 Special Books**

- Let us show you how to save all cost or obligation. Exactly how you can save money on everything you buy to eat or wear or use in your home.
- Here are a number of the special books we issue. In the entire list there may be but one or two or three that will interest you at this time. But by all means get that book or books in which you are interested.
- You owe it to yourself, in your family or at least in your own mind, to take advantage of this opportunity for saving.
- Check over the List Now
- |    |                |    |                         |
|----|----------------|----|-------------------------|
| 1  | Faiths         | 17 | Dairy Cargasses         |
| 2  | Plants         | 18 | Men's Fur Coats         |
| 3  | Organ          | 19 | Swing Machines          |
| 4  | Trunks         | 20 | Gasoline Engines        |
| 5  | Boating        | 21 | Gown Separators         |
| 6  | Bicycles       | 22 | Bedding Materials       |
| 7  | Furniture      | 23 | Shoes and Bangs         |
| 8  | Incubators     | 24 | Decorative Samples      |
| 9  | Well Paper     | 25 | Automobile Supplies     |
| 10 | Typewriters    | 26 | Bicycles—Motorcycles    |
| 11 | Glossary       | 27 | Baby's Dress and Collie |
| 12 | Feed Cookers   | 28 | Women's Tailored Suits  |
| 13 | Tank Hoses     | 29 | Women's Fashion Book    |
| 14 | Wire Pruning   | 30 | Hats—Machines—Machinery |
| 15 | Carriage Rags  | 31 | Men's Clothing          |
| 16 | Building Plans | 32 | Women's Fur             |
- Send To-Day:** Each of these books is already illustrated. This illustrated book shows you the exact price and the exact quantity of all the things you will find in the books. Pick out the book or books that interest you, write their number in the coupon below and mail it to us today.
- Sign and Mail Coupon NOW!**
- MONTGOMERY WARD & CO.**  
1326 and 14th Street, Chicago, Ill. This age, I want, I desire, I am interested in...  
Please send to my address below books Nos. ....  
Enclosed find \$... of cost.
- Name .....
- Post Office .....
- State .....
- Send coupon to the address nearest you

**ROYAL LEATHER ROCKER**  
Full Spring Seat and Back—Covered in Best Royal Leather

Look at the picture, doesn't this Rocker look like a high, broad, sturdy chair with a cozy spring seat? It is made of East German, solid maple frame, supported by six neatly turned smooth spindles, and massive floral carved posts, give it the distinguished and style that cannot be had in any other rocker. Frame thoroughly seasoned and high grade and glass finish. Price only \$3.85. Write today for full catalogue 610 (3-4) for number 610. Address: Lincoln-Leopard & Co., 1241 W. 37th Street, Chicago

**Parcels Post Merchandise Co.**  
A Positive Money Saving System—designed to save you money on things used in every home which we can send by Parcels Post Free Delivery. You save on every purchase. Satisfaction guaranteed. Let us explain and send you our Catalog of Women's and Children's Apparel, Handkerchiefs, Neckwear, Hosiery, Swiss Embroideries by the yard, etc.

**SPECIAL OFFER!**  
We will present you with a set of beautiful Swiss Embroidered Initial Medallions for the names of two friends to whom we can offer our service. Write today.

**PARCELS POST MERCHANDISE CO.**  
340 Fourth Avenue, New York City

**AGENTS \$4.95 A WEEK MENDEL'S**

Used all kinds of machinery, from power saws, belt saws, table saws, rotary saws, planers, jointers, etc. For work done by hand. For sale on terms. For any further particulars, write to us, or call on our salesmen. Collectors: Box 148, Amsterdam, N.Y.

**AUTOMOBILE VEILS**  
Made of a wood quality soft chiffon, 2 yds. long, 1 1/2 yds. wide, hemstitched ends. Colors: white, pink, blue, lavender, tan, grey, black, brown, navy. Price \$1.00 each. Postage paid. Send to Arthur Jensen & Co., 376 Cortez St., Chicago, Ill.

**BUTTONS** Send for Free Booklet  
MADE TO ORDER. Mail your cloth and size to SHERMAN BUTTON CO., 2725 Cortez St., Chicago, Ill.

**LEARN TO WRITE EARN \$25 TO \$100 A WEEK**  
We can pay you \$25 to \$100 a week to write for us. If you can't write, we will teach you. We will also pay you \$100 a week to write for us. We will also pay you \$100 a week to write for us. The Postgraduate School, 25 Page Bldg., Chicago, Ill.

**LEARN JEWELERS' ENGRAVING**  
A high standard and really learned trade, taught thoroughly by mail. We will teach you the complete trade in jewelry. You can get into the trade of this profession. We will also pay you \$100 a week to write for us. The Postgraduate School, 25 Page Bldg., Chicago, Ill.



**No. 1872**  
**No. 1873**  
**No. 1857**  
**No. 1858**  
**No. 1830**  
**No. 1842**



# OUR YOUNG FOLKS' DEPARTMENT

Conducted by Cousin Sally



## Kita and the Three Fire-Sticks

By Ponnie A. Nedwill—Drawing by E. B. Comstock

PART II.



NOW, when he had shown all that he had, Kita bought herself a fine sash of blue silk and an embroidered shawl for Risban and some token for each of her maidens. And the man sought to pack up his goods to depart. But the rough men would not suffer him to leave with all his wares, but they took them and divided them, and

each kept a part, and when they had taken all, they jeered and mocked the poor man, and put him outside the gate with empty hands. And they cared not at all, although little Kita pleaded and begged them not to be so cruel to the man.

And when Aramin returned that evening and was told of all that they had done, he only laughed and cried out: "Ye let him go easily, my men! He would have been a dainty morsel for my lions!"

But little Kita kept her three sticks secretly, nor even showed them to Risban, and she wondered much when she would have need to use them and what the strange man had meant about her father being in danger. And she was more afraid of Aramin and his men than ever. She wished her father would return.

Now on the third day, about the time of sunset, there came a great shout from the watchmen in the turret, and, lo! across the desert came a troop of camels. And when they were come near, it was seen that Mazaran sat on the foremost camel and with him were about fifty men. And when Kita heard that her father was coming, she went with Risban to Aramin and said:

"I pray you let me go out to meet my father."

But Aramin made answer roughly, "Get you up to the uppermost gallery. From there shall you look down and see how good a welcome your father will receive in the great court," and he smiled so wickedly at her that Kita began to tremble with fear. Nevertheless, she dared not disobey him, so she went with Risban and called all her maidens and stood on the uppermost gallery, and they looked down over the balustrade. And Aramin and his men were on the lower gallery on the opposite side, and they sat as in state looking down into the court.

Then while Kita wondered that Aramin should not be down-stairs to greet her father she looked down and saw eight men standing in the court, and they were the keepers of the lions. And each man held in his hand a key, and they stood each before one of the lions' cages. And there were eight strong ropes tied to the balustrade of the lower gallery and the ends of them hung down to the floor of the court. Then Kita, when she saw this, cried out to her old nurse:

"Oh, Risban! what does this mean? There is no one there to greet my father but the eight keepers of the lions, and why do they hold the keys of the lions' gates?"

Then answered Risban, "Alack! Alack, my child! I fear they mean to kill your father. See, they will open the gates of the cages and then climb up the ropes themselves to safety."

"But, Risban, my father is outside," cried Kita. "They cannot be so cruel!"

"They mean to let him in. Go away, child, go away. You must not see your father killed!" And Risban began to sob.

"Do you mean that they will let the lions out to kill him? Oh, Risban, Risban! Is this what the strange man meant?"

"Go away, Kita! Go inside!" cried Risban with the tears running down her wrinkled cheeks.

Then like a flash Kita thought of the three sticks and of what the Chinaman had said to her, and she ran into her sleeping-room and called to Risban as she ran and cried to her: "Get a torch and light it, Risban! Quick, quick! Take it out on the gallery!"

And Risban brought a flaming torch and held it in her hand and stood out on the gallery by the balustrade and she cried out to Kita, "I have brought the torch, but, oh, my child, what can you do with it?"

And Kita ran out with the three pointed sticks and stood beside Risban, and she looked down and saw the eight men go over and each unlock one of the iron-barred gates of the lion-cells. And when they had turned the keys, the men dashed back and caught hold of the ropes that hung from the gallery and climbed up upon them to the gallery and pulled the ropes up after them. Straightway the lions flung themselves with mighty roars against the gates and at the same moment the great door at the entrance to the court swung open and Kita saw her father walk into the court. Hardly had he crossed the threshold when the door was slammed close behind him and he was left inside. For a second he stopped, startled, and looked around him in amazement. Then Kita heard one of the gates burst

open and a great tawny lion bounded into the center of the court. Crash! dropped another gate. Crash! another and another!

"Hold the torch lower, Risban, oh, Risban!" screamed Kita, and thrust the pointed end of the three sticks into the flame. Immediately they flared up, hissing loudly and Kita threw them frantically into the court below. Straight into the midst of the lions they fell, and as they struck the pavement they exploded like three thunderbolts and three great balls of fire rose up into the air as high as the second gallery, then broke and fell in thousands of stars of blazing fire.

Instantly with howls of terror the lions sprang back and crouched against one of the fallen iron doors while Mazaran stood unharmed on the other side of the fire with his back against the great doorway.

And now the palace was all confusion, men shouting and women screaming and tumbling over one another to get out. Sparks from the great balls of fire had caught the curtains of the second gallery and set them aflame, and the whole place seemed to be full of smoke and fire.

Now there was a flight of steps cut in the stone on the outside wall of the palace, and down these steps fled Aramin and his men, shrieking with fright for they knew not what had happened. They thought the fire had come down from the sky. And after them came Kita with Risban and all her maidens, and Kita and Risban ran around outside the palace until they came to the great door that led into the court, and together they drew the heavy iron bolt and swung open the door. Straightway a great cloud of smoke rushed out into their faces and they could not see for the thickness of it.

"Father! Father!" cried little Kita. "Come, the door is open! Come!" and her voice was choked in her throat. But Mazaran heard and came out to them with his face wrapped in his mantle, and he could scarce stagger through the doorway. And when he had leaned up against the wall old Risban closed the door quickly and bolted it, for she was all trembling for fear of the lions.

And Mazaran, after he had gained his breath, spoke and said, "Is that you, my little Kita? Come here, my child, and let me kiss you, for I thought a while since I should never see your face again!"

Then Kita took her father's hand and led him away from the door, and all the men servants and the maid servants who had escaped from the palace came and crowded around and welcomed their master and rejoiced over his wonderful deliverance. But Aramin and his men had already mounted camels and were fleeing across the desert.

Now the palace did not burn to the ground, because the walls and galleries were built of solid stone. And no single person was lost in the fire, for all escaped. And in due time Mazaran rebuilt the palace and made it more beautiful than ever.

In this wise was the great Mazaran saved from the cruel treachery of Aramin by the hand of his little child Kita. But Kita always said that it was the poor man from the land of China, with his hair in a braid down his back, who saved her father. But she never saw him again, nor ever thanked him for his good service.

And Kita has never since seen nor heard anything of the cruel and treacherous Aramin who tried to take possession of Mazaran's palace which King Jemshid the Magnificent had given him for his many valiant services.

[THE END]



... the lions flung themselves with mighty roars against the gates ... and Kita saw her father walk into the court"

## Letters from Cousin Sally's Club Members

DEAR COUSIN SALLY—  
I received my club button this morning. Many thanks for it. I will try to be a loyal member of the club, and I always want to follow the club motto.

I go to the Methodist Episcopal Church and Sunday-school. Our Sunday-school offers pins to those who are perfect in attendance and to those who are on time every Sunday. I have had every pin that has been given. Three of the pins you can keep thirteen Sundays. One pin you can keep one year, and after you have had that one they give you a gold pin to keep. They have celluloid, copper, silver and gold pins. Our Sunday-school had a picnic last Friday at a pleasure resort, and we all had a good time.

From your cousin,  
HILDA FISHER, Age Eight,  
Edgewood, Iowa.

DEAR COUSIN SALLY—  
You may be sure I was surprised and delighted when I received the book you sent me. It is certainly a nice gift and I thank you very much for it.

I have decided to compete in the next contest, but, Cousin Sally, I do not expect a reward every time I try in a contest. I merely wish you to see my work, and it is excellent practice, too.

The four stanzas I am sending, "At Grandma's," will please you, I hope.

Just a word about our club. I am pleased to know how many boys and girls through-

out the country are learning what a fine thing it is to be a member of Cousin Sally's Club, and I hope that it will continue to increase in the future as it has in the past.

Your faithful cousin,  
FRANK C. HOUT,  
Middlebury, Indiana.

DEAR COUSIN SALLY—  
I am president of a club called "The B. B." "Busy Bees," you say to yourself. No, you are absolutely wrong. It is called "The Butterfly Band."

We opened the club by giving a butterfly party. A great many butterflies of different sizes and colors were made. But first I must tell you about the invitations. They were written on the inside of paper butterflies, four lines on each wing. The butterflies were then folded together. Here is the verse, which was original:

I come from the land of birds and flowers,  
And I bring this message to you:  
"That you are to spend two happy hours  
With me and my comrades, too,  
At the home of our friend Miss Iloene,  
Who lives across the street.  
Come to-morrow at 2 P. M.  
And my pretty sisters meet."

As many butterflies as there were guests were printed with large numbers. One was drawn out by someone who was not in the

party, and the number drawn out was put on a prize. Strings were tied on the butterflies, and they were put under a box with the strings hanging out. The girl drawing the string with the number on it that corresponded with the number on the prize received it.

Next a large flower drawn on a sheet of paper was fastened on the wall. The game was to see who, blindfolded, could pin a butterfly nearest the center of the flower.

A story about butterflies was written, in which the word butterfly occurred twice. A color for each guest was also worked in. The children were lined up according to their wishes, and the first word of the story fell on the first child, and so on around until the story was ended. The two persons to whom the word butterfly fell were awarded prizes, and all were cautioned to remember the color that fell to them. One more thing about the party and then I shall speak of something else.

Five butterflies were hidden for each guest. They were in the colors that were spoken of in the story. Each girl hunted for her own color. If another color was found, it was put quietly back. The girl who found all her colors first received a prize.

We had a very nice time at our butterfly party. Don't you think the idea quite original, Cousin Sally? We girls are very much interested in our club work. The members range from four to fourteen years of age.

I am very anxious to become a member of your club. Enclosed please find five cents in stamps, for which please send me club button. Lovingly,

ILOENE MILLER, Age Fourteen,  
Sabina, Ohio.

DEAR COUSIN SALLY—  
I think my C. S. C. pin is a beauty, and I am so glad to be a member of your club. I will try to be a good member and I would like so much to correspond with some of the cousins.

I am nine years old and will be in the fourth grade this winter. I can hardly wait for school to begin. I like to go to school, and I am saving all my money to help pay my way to college when I am a little older. Mama gives me ten cents a week for taking care of the baby. I have thirty-one Indian Runner ducks and three dollars of my own already saved up.

Mama is a music-teacher, and she is giving me lessons on the piano. I have learned one piece called "The Merry Dance" and I am soon going to learn another.

We live on a farm and have lots of horses, cows, pigs and chickens. Papa is putting up hay and has several men working for him, so I help Mama cook and wash dishes.

Please put my name in the list of those who would like to correspond with some of the cousins. Your loving cousin,  
LYNDALL SHERA,  
Letts, Indiana.





Students Judging Apples



Students Scoring Corn



Students Comparing Horses

# Farm and Fireside Will Pay Your Expenses

## Attend the Agricultural Short Course This Winter

**TO GET** the most profit out of even a small farm demands a thorough knowledge of natural laws underlying agriculture. Where can this knowledge be obtained so swiftly, economically and safely as at an Agricultural School?

### Agricultural Training Is Vitaly Important

It takes the same kind of brains to succeed on the farm as it does in the city. It requires the same mental application. A great financier has recently said that "ten weeks at an Agricultural School will be worth thousands of dollars to every boy who is going to own or manage a farm."

The day of the opening of new farm lands is practically over. Henceforth a farmer must stand his ground and fight his battles with brain rather than brawn. He must know what to put into the soil to obtain the best results. He must know of the chemical composition of the earth in every section of his farm. In the presence of such conditions to dispense with a careful training in agriculture is to place a distinct handicap upon the young man who would achieve success and distinction on the farm. Farming to-day is a progressive vocation. It is vitally necessary that the farmer's mental equipment be up-to-date.

We Americans are past the stage where we are content with a bare living. We want not only the necessities, but also the comforts of life. The farmer of to-day wants to be as prosperous and successful as the best city man. To attain this we must study.

Do you want to take the short course at the State College of Agriculture? If you do, FARM AND FIRESIDE is willing to pay your expenses. FARM AND FIRESIDE offers you a scholarship of \$100 in cash which will defray all your expenses during the short course, including board, lodging, books, tuition and railroad fare.

### A Great Chance for Farm and Fireside Folk

Just as soon as you send us the Nomination Blank attached below we will send you a handsome Scholarship Diploma engrossed with your name and address and officially signed by the Scholarship Committee.



You Will Receive Your Scholarship Diploma at Once

Yesterday's mental equipment will not operate in harmony with the new ideas, the modified farm conditions and the more up-to-date machinery of the present time.

### Agricultural Schools Are Crowded

Farm boys everywhere are recognizing this important fact. In every agricultural state in the Union farm lads are flocking to the Agricultural Schools to learn more about farming. In many states more applications for admission to our Agricultural Schools are received than the schools can accommodate. But FARM AND FIRESIDE has reserved a place for its scholarship candidates at a number of the big Agricultural Colleges. The Agricultural Schools represent all that centuries of farming has taught us in this country and abroad. The teachers at the Agricultural Schools have spent their lives in studying how to get bigger profits, how to feed and care for stock more economically, how to make every department of farming more productive and profitable than in the past. In the past the custom has been to require only special training for the doctor, the lawyer and the teacher. As a result professional life was considered more profitable. But to-day the farmer who is as well trained and as well informed about his occupation as a professional man has a vastly more profitable, enjoyable and independent occupation. When farm work is directed by a trained intellect, it ceases to be drudgery and becomes an interesting and fascinating occupation. This is one of the gratifying results of the training offered.

## Get Ready Now to Take a Course in Agriculture

### Endorsed By the Agricultural Colleges

The FARM AND FIRESIDE Agricultural Scholarship has received a hearty endorsement of the big State Agricultural Colleges in which these great scholarships will be offered.

Below is the list of the Great Agricultural Schools in the United States to which FARM AND FIRESIDE will send its Scholarship winners. Choose the school which you wish to attend:

- Ohio State Agricultural College, Columbus, Ohio.
- Indiana State Agricultural College, Lafayette, Indiana.
- Illinois State Agricultural College, Urbana, Illinois.
- Minnesota State Agricultural College, St. Andrew's Park, Minn.
- North Dakota State Agricultural College, Fargo, North Dakota.
- South Dakota State Agricultural College, Brookings, S. D.
- Nebraska State Agricultural College, Lincoln, Nebraska.
- Kansas State Agricultural College, Manhattan, Kansas.

- Missouri State Agricultural College, Columbia, Missouri.
- Iowa State Agricultural College, Ames, Iowa.
- Pennsylvania State Agricultural College, State College, Pa.
- West Virginia State Agricultural College, Morgantown, W. Va.
- Mississippi State Agricultural College, Agricultural College, Miss.
- North Carolina State Agricultural College, Raleigh, N. C.
- New Hampshire State Agricultural College, Durham, N. H.
- New York State Agricultural College, Ithaca, N. Y.

### A Chance for All Our Subscribers

Any FARM AND FIRESIDE family who has no member to enter for this scholarship is privileged to pass this opportunity on to some worthy boy or girl who is ambitious for a course in agriculture or domestic science. It should be the ambition of every young person who is going to live on a farm to obtain an agricultural education. A farmer's

short course is almost essential to those who get the most out of farm life. Every candidate has a golden opportunity to get this scholarship. Remember that the FARM AND FIRESIDE scholarship is not competitive. The ambitious candidate is sure of a scholarship.

### Fill Out This Nomination Blank

Fill out this nomination blank and we will send you free of charge full information about the scholarship, including our illustrated Scholarship Leaflet.

We will also reserve a place for you at the State Agricultural College so that the scholarship will be ready and available just as soon as you have qualified.

We will also send you full instructions on just how to proceed, telling you just what you will be expected to do to merit our scholarship and attend college this year.

FARM AND FIRESIDE, will not place candidates under any lasting obligations. You will be asked as an evidence of good faith to do a small amount of extension work in your community.

### NOMINATION BLANK

Scholarship Committee, FARM AND FIRESIDE, Springfield, Ohio

I desire to become a candidate for the FARM AND FIRESIDE Agricultural Scholarship, cash value \$100.00.

Name .....

Post-Office .....

Rural Route.....

County .....

State.....

Which of the above-listed schools does candidate wish to attend?.....

.....

Reference.....

Post-Office .....

Address .....

**This Scholarship is Good for any Course at any of the above Colleges**



## Growing Interest in Bible-Study

By John E. Bradley, LL. D., Ex-President of Illinois College



THE new interest in Bible-study is one of the most encouraging features of our religious work. Its extent and rapid growth are surprising. Many adult Bible classes have sprung up in Sunday-schools; others which have had a longer existence now evince new life. Magnetic men and women are in demand as teachers of adult classes. Here are a few instances:

A Bible class is started in a lonely neighborhood in New Hampshire, where there is no church, and quickly grows to a membership of 27—men coming several miles to attend it.

A Sunday-school in an Ohio village organizes a men's Bible class and in less than a year it numbers 197—more than the whole school had numbered previously.

A city church in Illinois has an adult Bible class of 289.

A Massachusetts Sunday-school convention recently held its first session in the morning in one body, but separated into four sections for the afternoon session. The Bible-class section proved to be larger than all the other sections put together.

Last winter, in Toronto, 1,200 men from Bible classes in that city sat down to a fellowship banquet—twice as many men, it is said, as ever rallied to the biggest political banquet in that beautiful city.

Now, why do busy men and women, many with their industries and cares, thus join in the study of the Bible? For various reasons, no doubt, but largely because it affords so complete a change from the grind of daily tasks. We need to break the fetters which bind us to our work, however good or important it may be. And we need not mere diversion, but rather encouragement, thoughts that are high and ennobling. We need greater familiarity with truths which take hold on life and immortality.

A similar impulse to study the Bible has been shown in the Young Men's and Young Women's Christian Associations all over the land. Hard working men in the railroad Y. M. C. A.'s meet regularly one evening a week to study the Bible. The county Y. M. C. A.'s have found Bible-study particularly successful with boys in the rural communities—whole associations taking up the work.

The moral influence of this study finds an illustration in a Bible class of one hundred boys in New Haven, Connecticut, mostly high-school students, who recently voted to repeat an examination in which there had been cheating.

Nowhere has the new interest in Bible-study been more marked than among college students. Ten years ago, President Thwing of Western Reserve University published facts and figures in a magazine article which indicated the astonishing and wide-spread ignorance of the Bible among students. No doubt such ignorance still remains among large numbers of them. But a wave of enthusiasm for Biblical study has been started which is spreading among higher institutions of every class.

In September, 1904, a company of young men were gathered in one of the fraternity houses in Michigan University. A student who was then captain of both the football and baseball teams of the university said that, as they knew, he had been active in college life, and now, that he had come to his last year in the university, he wanted to say to them that he realized that students face some pretty serious problems and temptations in college. He thought these problems could best be considered in connection with the study of the Bible.

"I confess," he said, "that I know little of the book myself, but I am determined to begin its study and, if there is no one else to do it, I will lead a group of athletic men in my own fraternity house." A surprising number of the company immediately expressed a desire to join in the study, and the result was the formation at once of numerous groups for Bible study in fourteen fraternities in Michigan University.

The movement, thus begun, spread like the dawn of a new day. Last year, there were 4,939 fraternity men studying the Bible in voluntary groups in their own society houses in this country. Schools

and colleges having no fraternities responded no less freely. All sections and all classes of institutions have been reached. In the United States and Canada, 539 colleges reported large numbers last year pursuing Bible-study in some form—more than 32,000 being in self-taught, voluntary groups. These figures are merely suggestive—straws that show which way the wind blows.

People who read of the enthusiasm shown at an athletic contest or other college event often think of a college as only a place for gaiety and display. So it is well to remind ourselves that student life is a life of earnest work; the festivities are but bubbles which now and then appear upon the surface of the deep, still river. The vast majority of the 200,000 students in higher institutions in the United States and Canada are boys and girls from plain, quiet homes. They are not given to frivolity.

It must be a source of great satisfaction to the parents of tens of thousands of these youths, whose homes are on the farms of the Middle West, to know that students are thus turning of their own accord, and in such numbers, to the study of the Bible—to know that their sons and daughters are in an atmosphere which honors the Word of God and studies it for guidance in the midst of conflict and temptations.

Parents will also be glad to know that these were not weak or "goody-goody" students, but that they included the leading men in their various colleges, as is shown by the fact that 795 of them were class presidents, 885 were prize-winners, 696 were editors of college papers, 1,383 were members of college glee clubs and 1,445 were members of university football teams.

The college faculties have not been slow to recognize the educational value of this amount of Bible-study. They also testify to its moral value. It is one thing to commit to memory a certain number of Bible verses; it is quite another thing to study Bible characters and Bible principles and make them practical in our own lives. This study is already bearing fruit in more thoughtful habits among students, greater appreciation of personal responsibility and higher aims as these young men and young women look forward into life.

## Thou Shalt Sow, but Not Reap

By Albert F. Trams

HAVE you ever met the disappointment that was once your royal hope with something of the splendid laughter that sounds in the voices of Wagner's Siegfrieds and Brunhilds? Then there is no terror for you in the word of the Lord that came to Micah saying: "Thou shalt sow, but thou shalt not reap." But you, who for the first time look into the emptiness of infinity, are less courageous. You have dreamed, and struggled, and hoped; your eyes have ached to glimpse the horizon beyond the "Desert of Waiting." But the night is come, and you are alone with the stars.

Let me anoint you with my alchemy: "Take heart again."

Failure isn't all failure. The heart alone can measure defeat.

And so when you stand trying to decipher Life's cryptogram, read from it this truth: "The successful man or woman is one who has tried, not cried; who has worked, not shirked; who has lifted the burden, not merely told someone else how to do it; who has overcome his disappointment, not simply endured it; who has conquered his sorrow, not quietly borne it; who measures the effort, not the result." After all, the result, that which the world measures, is not the sum total of a worker's success. To have worked, to have had an ideal, and then to have directed every energy, every effort, every little thing done in life toward its attainment—that to me is SUCCESS. The result we must leave to time.

"Life is too short to gather the harvest—we can only sow."

And after all there is more genuine pleasure, more real joy, in sowing than in reaping. For then our joy is double: we sow in God's sunshine, and we reap in the shadow of our own dreams. And wasn't it beautiful, our dream of the harvest that was yet to be? Was there not joy enough in that to compensate the disappointment that was ours when the harvest failed? Surely! So let us fare on. Let us con-

tinue to sow our little measure of seed and to build our hopes upon fields white with the ripening grain. Let us work and toil, and when the night comes let us lay down our heads, aching; let us fold our hands, tired; let us see the harvest that we planned to be the reward of our labor. Then let the morrow come; and with it aching head again, and tired hands; tears also, there may be now, and heartache. But with it will come the splendid courage to take heart again.

The right to mother your home, the joy to anticipate that for which you do and dare, is a divine inheritance.

I know I should not now be teaching if I measured my success by immediate results. No, I measure all my success in the joy of the work. I do the best I know every day, and in that I take pleasure. I sow the best I have. Others must reap the harvest. If they fail, the suffering will be theirs. For sufferance is the badge of them that trespass on the law of life. And the law of life is that we shall SOW.

You have heard it said, "Get out of life all the beautiful that it holds." Suppose you study out the fallacy in that. In the meantime give to life all the beauty that a Divine Creator has endowed you with. That is Sowing.

You say that we do not always know what the law is. Have you ever felt the joy of a new discovery? The tightening of the heart-strings when your dream came true? Would you miss that joy for the knowledge of any law? Go in search of the Law. Sow and find the "open sesame" to human hearts. Until that time of greatest discovery you must still wear the badge. He who is so wrapped in self-satisfaction that he does not feel a thrill of sympathy with the soul-cry of an unanswered prayer, or with the heart keeping watch over dead hopes, and the ruins of visions and dreams, has let the brains in him wither and grow numb. Heart-Thanatopsis is his, and he himself a mockery of life's divine intent.

Your supreme desire may go to the grave unfulfilled; your beautiful dreams may waken to wretched reality; your glorified visions may be as a tent that is gathered and gone. But may the supreme calamity never be yours to let Sympathy knock unresponded to at the door of your heart.

And when your life is filled with sorrow, and the storm clouds show neither rift nor shadow of turning, pray thou thy prayer, and harken unto the voice whispering thee to "travel the highway with seeing eyes, helping hands, a tender, compassionate heart; awaken something of the Divine in everyone thou passeth; put into thine own crucible every sweet and every bitter experience that fate may send thee; touch gently and with an understanding heart the crystal vase of another's alchemy, lest thy rude fingers spill the precious ointment that another has distilled from the agony that was his alone; mitigate human needs; sympathize with human weaknesses; and, out of the knowledge thus gained of the heart-cry of humanity, distill in thine own self the precious attar of faith that will enable thee to meet disappointment with something of the splendid laughter that sounds in the voices of Wagner's Siegfrieds and Brunhilds. Then will there be no terror in the word of the Lord that came to Micah saying: "Thou shalt sow, but thou shalt not reap."

## Work We Love

By Elizabeth Ellis Scantlebury

"WE LOVE the work our Father gave,"

The snowflakes softly said;  
"When flowers sweet lie down to sleep  
We tuck them up in bed."

"And we have loving work to do:  
When ends the flowers' night  
We waken them," the raindrops cried,  
And laughed the sunbeams bright.

"We love our work," the breezes sang;  
"To children, in the spring,  
A story of the blossoms fair  
And hidden flowers we bring."

Then sang the little children all,  
"There's something we may do,  
If sun and rain and breeze have work—  
The tiny snowflakes, too!"

"With willing hands and loving heart,  
And with a smiling face,  
We'll each one help our home to make  
A pleasant, happy place!"

## A Daily Meed

By Anna H. Quill

THE busy mother should get some pleasure, some relaxation, every day from the monotony of household duties. Have you ever noticed, after hearing good music, or reading a good book, or attending an entertainment, that the impression made on you will remain for a long time? It is the same after seeing a fresh landscape or even a happy face.

Everyone whose road runs along the same way day after day, week after week and year after year needs these pleasant impressions to keep the crowding cares of every-day life from engulfing them and making them narrow and hard.

What a fine thing it would be if mothers, and fathers, too, would cultivate a sense of humor. It helps wonderfully in pushing care away. To the person with a sense of humor there is always a funny side to every difficulty, and such a person will look for that side before deciding or condemning. To the person who is able to get pleasure out of life, the day is never so long; he finds a gleam of silver in every cloud.

Try making your own sunshine. No matter how heavy your heart may be, try to speak pleasantly to everyone, and smile, for your smile is somebody's sunshine.

Let no day get away from you without extracting some pleasure from it. Read a good book, hear good music, take a walk in the country, a ride, or visit a friend; do something that will make your day better.

Some find great pleasure in visiting a sick friend. Perhaps you dislike to do so because you have nothing to take her, no flowers, fruit or books. Don't let that discourage you, take a little sunshine along. Your friend will be glad of that. A bright, encouraging talk helps wonderfully in the sick-room. It cuts the doctor's visits short. You do not have to pay for the sunshine or good cheer, but you do have to pay the doctor and the nurse.

## A Romance of Statuary Hall

[CONTINUED FROM PAGE 18]

"Chance has brought them to light," he said, "as such evil deeds as yours are bound to be brought, sooner or later."

"Don't you be so brash, Mr. Whipper-snapper of a clerk," raged Lawyer Crook. "There was nothing in what I said, nothing. It might have referred to a thousand things as impertinent as you are."

"But it did refer to just one thing," persisted the young man dauntlessly. "Remember, you two precious scoundrels passed through here not a half-hour ago, as oblivious as you were just now to the acoustic properties of this hall. Remember what you said then: 'The Meacham papers are among the old records of the Office of the Commissioner of Indian Affairs, though no one suspects it.' Aha! that is rather pertinent, isn't it? I am rather pertinent, am I not? At all events, it is for Senator Ryland to say. He'll find out whether the Meacham papers are in the old warehouse, never fear. He'll find out whether they show, as you know they do, that Ralph Malby's title to the river lands you tried to steal is complete and perfect. Now, be off, if you're wise, as quickly as the Mulcimer Company bill will go off the calendar. My word for it, you can't go surer and quicker."

As the two men ink down the circular stone steps over which their worthy predecessor had bumping rolled, the young man shot fleetly across the hall to the reception-room set apart for ladies. There in the chair behind the mammoth statue of Lewis Cass sat Clara weeping.

"Oh," she cried, "I heard every word. How brave and clever and good you are. You have done everything I hoped to do."

"No, my dear," replied the young man, not pausing this time to apologize, "it was your pluck and devotion in coming here all alone that brought about the victory. Don't cry, please. The old homestead is saved, with its vine-clad walls and the little creek running down to the broad river and the sycamores bending lovingly—"

"Why, why," gasped Clara. "I didn't say anything about all that—there is nothing about it in the papers. Was my dream true, after all? Are you, oh, are you—"

"Yes, I am Harry, Harry, come to you at last, you dear," answered Harry Manley, repeating the words with which his true love had unconsciously greeted him.

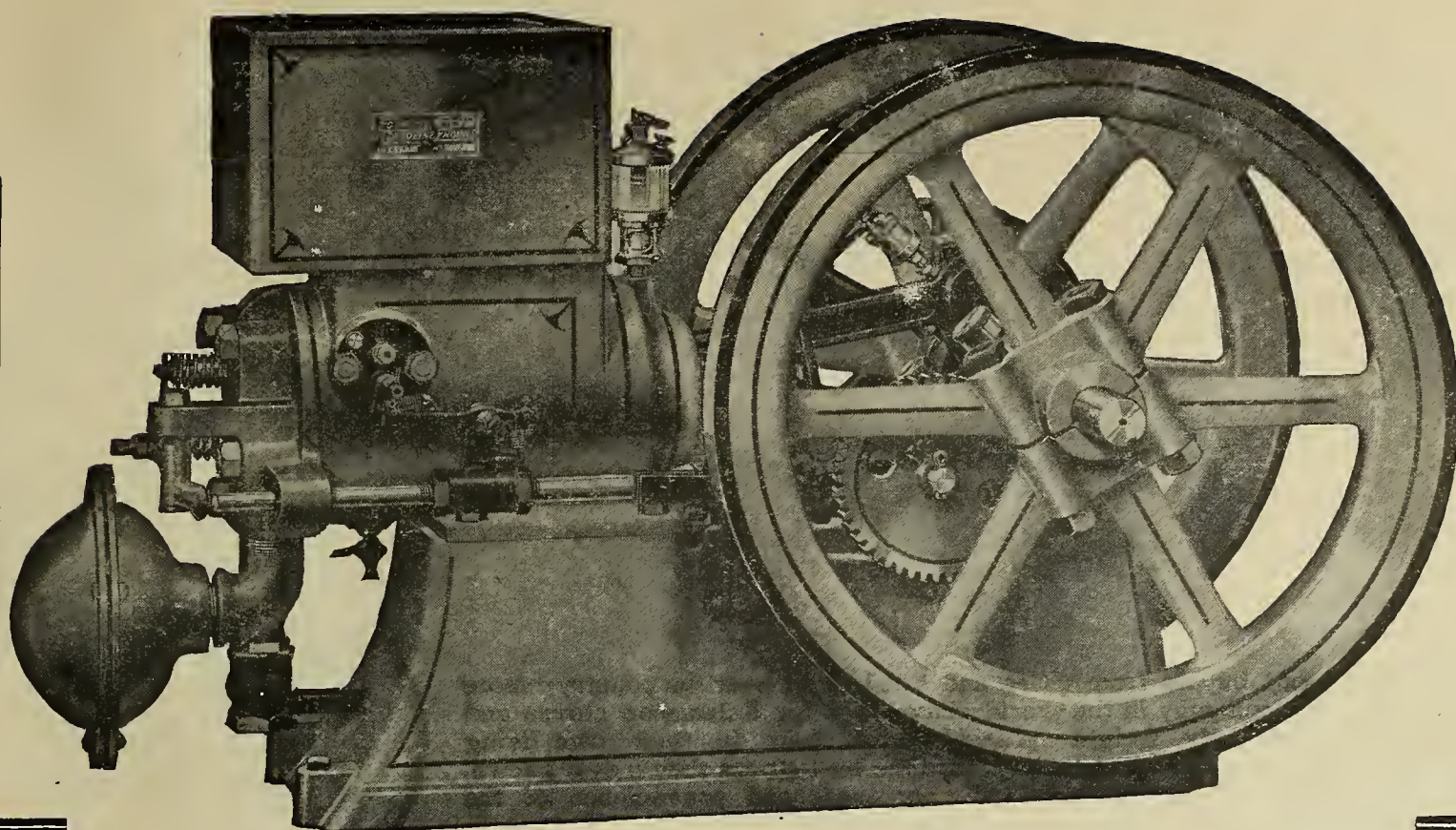

1½-Horse Power  
**\$2995**  
 —  
 2-Horse Power  
**\$4295**  
 —  
 4-Horse Power  
**\$7475**

6-Horse Power  
**\$10445**  
 —  
 8-Horse Power  
**\$16895**  
 —  
 10-Horse Power  
**\$24345**

# We Have Saved Millions of Dollars for American Farmers

on Cream Separators, Buggies, Wagons, Farm Implements, Sewing Machines, Pianos, Organs and other necessities, by going back to original sources of supply, assembling the raw materials and producing these articles in our own factories. We have put into the pockets of our customers every cent of the extra profits and unnecessary expense of the "agent-and-middleman" system of distribution.

*Now comes our latest and perhaps biggest sensation in manufacturing enterprise, the newly completed engine works in which we are building the celebrated stationary and portable, 1½ to 10-horse power*

## Economy Gasoline Engines

### PUMPING OUTFITS

Users of gasoline engines are paying from one-third to one-half more than actual value for engines bought through the wasteful out of

### WOOD SAWING OUTFITS

date "agent-and-middleman" method. Never was there a greater opportunity for us to serve our customers than in gasoline engines. Never has there been a better chance for us to demonstrate the practical value of our "factory to farm" method of merchandising.

**The Remedy** The remedy for high prices and unjust profits in gasoline engines is at hand. We now own what we believe to be the best engine building plant in the country, equipped with all the latest improved automatic and labor saving machinery, manned by an organization of the highest skill. In this perfect engine factory we have made a complete investigation of the gasoline engine question. We know exactly what the farmer's gasoline engine must do, and we are building the engine that will do it. Every problem has been met squarely and solved honestly. We offer no makeshifts or compromises in the Economy Gasoline Engine. In the testing department of our engine factory every engine on the market has been actually operated and tested alongside the ECONOMY.

The result of these tests shows Economy Engines to be so perfect in their quality, power, efficiency and durability, that we now sell them under a lifetime guarantee and with the privilege of a sixty days' trial.

How we have knocked the bottom out of the high prices that have formerly ruled the engine trade, together with the whole story of our great engine building plant, with its perfect machinery and its splendid organization for raising quality and lowering prices, is all told in our new Gasoline Engine Catalog. The coupon to the right properly filled out brings it to you. The Economy Gasoline Engine Catalog puts the whole situation before you so clearly that you will shake hands with yourself and will want to shake hands with us after you have read it.

Before you turn this page, or lay the paper down, **TEAR OFF THE COUPON.** No, don't tuck it in your pocket! Fill it out and mail it to us without delay.

**Let Our Experts Answer Your Questions.**

You do not need to be told that a gasoline engine will earn its cost several times over in a few months. You are probably figuring on letting a gasoline engine take the place of hand labor in the house, dairy and laundry, letting it help the windmill when there is no wind, doing by gasoline engine power some of the work now done by your horses.

**How Much Power Do I Need?**

It won't cost you a penny to get an absolutely accurate answer to this or any other question connected with power for the farm. Just write and tell us what work you have for the engine to do and our engineers will tell you exactly what power you require and how much it will cost you. If a 4-horse power engine will do your work as well as 6-horse, our engineers will tell you so. If you actually need 4-horse power to operate your machinery, our engineer may be able to show you where it would be better to purchase two 2-horse power engines instead of one 4-horse power. Tell us what your needs are.

Write us today and let us solve your power problems. The engineers who made the Perfected Economy Gasoline Engine are ready to give you expert advice without one penny of cost to you.

**SEARS, ROEBUCK AND CO., Chicago, Ill.**

Please send me a copy of your new Economy Gasoline Engine Catalog.

Name \_\_\_\_\_

Postoffice \_\_\_\_\_

R. F. D. No. \_\_\_\_\_ State \_\_\_\_\_

P. O. Box No. \_\_\_\_\_ Street and No. \_\_\_\_\_

# SEARS, ROEBUCK AND CO., CHICAGO, ILL.

# Buy Your Stove on the Plan That 170,000 People Have Found Is RIGHT

## Freight Prepaid—30 Days' Trial—360 Days' Approval Test—CASH OR CREDIT

170,000 and more intelligent buyers from cities and hamlets all over the country—more customers than any other stove company in the world—have sent for Kalamazoo stoves and ranges on trial—got them promptly freight prepaid—tried them in their own living rooms and kitchens, and then kept them because they were the best stoves they'd ever known. Isn't that solid, convincing proof of the fairness and squareness and convenience of the "Kalamazoo Direct to You" selling method and Kalamazoo quality?

Now, why shouldn't *you*—no matter where you live—no matter what kind of a stove you want—do the same? Just try a Kalamazoo for 30 days. Let the stove itself tell you the story of Kalamazoo efficiency and economy of operation—of its superiority to every other stove. See the *visible evidence* of the perfect materials, painstaking manufacturing and rigorous inspections—every piece inspected many times over.

You get the peerless Kalamazoo as easily as an ordinary stove at your dealers. Shipment made the same day—at the latest within 24 hours of receipt of order. You'll understand why we boost the Kalamazoo when you see it in operation in your own home. But we want to say right now, that if for any reason you don't feel satisfied and more than satisfied, back comes the stove or range after 30 days' trial—freight paid by us both ways. We don't charge you a cent for the trial. We want *delighted* and *enthusiastic* customers or *none*. So we make this offer that gives you a stove-buying opportunity unequalled in solid advantages to you.



Kalamazoo Radiant Base Burner

A 360 days' trial in addition—don't forget that. And we offer you cash or credit terms, just as you prefer—the same terms and better than your dealer offers.

Best of all the price is the *direct* price—the *wholesale* price—the manufacturer's price that no dealer can hope to equal. Read the reason why we can make such a price.

**"A Kalamazoo Direct to You"**  
TRADE-MARK REGISTERED  
And Gas Stoves Too

Send Coupon or Postal for FREE BOOK

## Save \$5 to \$40

Shipment guaranteed the same day order is received.



Your purchase of a Kalamazoo means an actual cash saving of from \$5.00 to \$40.00. Our customers' letters prove this.

Your experience will, too. Get the Kalamazoo stove book and compare our prices with your dealer's prices. Get the very *lowest quotations* you can find anywhere and you'll see that we offer you *still lower prices*. You only, as the user of the stove, can buy from us. No dealer can buy a Kalamazoo a penny cheaper than *you* can buy it—not one goes into the jobber's hands. There's no dealer's

profit or jobber's profit or the profit of any middleman whatever for you to pay. You don't have to stand for the dealer's rent and clerk hire—interest on stock and depreciation on old goods and loss on goods that he has to carry over, or unpopular patterns that he happens to be loaded up with. You must not think Kalamazoo stoves are expensive because they are the best. As a matter of fact they sell as low as \$6.50 and up—east of the Mississippi. Remember, you get a quality such as you'll say yourself you never got in any other stove no matter how high the price. Kalamazoo Stoves are made by old, experienced manufacturers who saw the disadvantage and expense of the old fashioned manufacturer-to-jobber-to-dealer selling method and decided to deal direct with the customer. We know by experience just how to make stoves to satisfy you. More than that, we guarantee them—with \$100,000 Bank Bond back of the guarantee (see our catalogue), and any repairs needed—even if the break is no fault of the stove—it will be furnished at *cost* or *below cost*, and shipped same day order is received.

## Send the Coupon for the Big Stove Book — Free

Choose your stove or range from hundreds, not from dozens. Our big stove book gives you a choice that your dealer could never give you. In fact, the biggest city stove dealer couldn't show you one-fourth the styles and sizes on his floor that you'll find described and truthfully illustrated in this big reference book. No dealer could give you the stove facts this book contains—most of these are *inside facts* the dealer himself doesn't know. You'll want to read this book over carefully before you buy a stove. You'll need these valuable facts about stove

making and stove selling as a *protection*. You get our startling *wholesale price quotations*, all information about the *30 day trial*, *300 day approval test cash and credit terms with the book*. All you have to do is to send the coupon with your name and address. Paste it on the back of a postal or put it in an envelope. Send a letter, if you'd rather. But get the book at once—have it handy when you're ready to buy. Don't think of buying *anywhere* until you have the Kalamazoo book. Send the coupon or write us a postal *right now*.



Kalamazoo Queen Range for hard coal, soft coal, coke or wood.



Oven Thermometer Saves Fuel

Kalamazoo Stove Co., Mfrs.  
Kalamazoo, Mich.

### COUPON

Cut or tear off this coupon and send it for the Big Kalamazoo Stove Book—MAILED FREE.

Kalamazoo Stove Co., Mfrs.  
Kalamazoo, Mich.

Send me your big illustrated 100 page Kalamazoo Stove and Range Catalogue, No. 183, free of charge—postage all paid.

Name.....

Street No. or Rural Route.....

City..... State.....

1544













