

Class [redacted] Book [redacted] v. 20

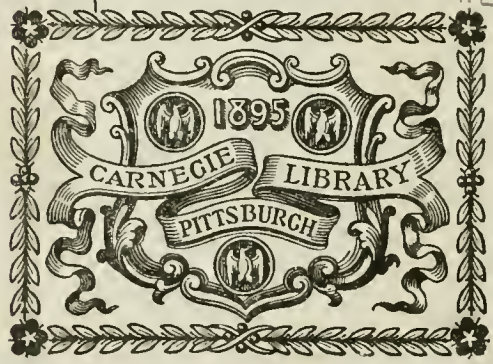



















# Railway and Engineering Locomotive

INDEX FOR VOLUME XX, 1907 (Illustrated Articles) Marked \*

## A

Adv. Space and Transportation, 107.  
Air Brake Dept., 25, 75, 123, 169, 215, 261, 323, 373, 417, 460, 505, 549.  
Air Brake Articles.  
\*Air Brake on Electric Locomotives, 26.  
Air Brake Maintenance, 75.  
\*Air Brake Men's Convention, 323, 261.  
Angle Cock, Defect of the, 505.  
\*Air Compressor D E G. (Electric), 76.  
Air Pipe, Broken, by G. W. Kiehm, 460.  
Air Pump Trouble, Peculiar, 170.  
Brake Beam Release Springs, 373.  
Brake Equipment, New, Defects of, by G. W. Kiehm, 169.  
Brakes Fall to Apply, Why; by C. M. Kidd, 417.  
Brake, High Speed, 460.  
Brake Pipe Pressure, Difference in, 505.  
Braking Power on Grades, 170.  
Brake Test in Round House, 417.  
Brake Work and Train Weight, 215.  
Driver Brakes, etc., by G. W. Kiehm, 118.  
\*Duplex Compression, 417.  
E. T. Equipment, Water in, 460.  
\*Engineer, What the, May Do, 505.  
H6 Brake Valve, by G. W. Kiehm, 505.  
K Triples Buzzing, 373.  
Locomotive Brake, Keep Up, 170.  
\*M Triple Valve, 122.  
\*M Triple Automatic and Straight Air Valve, 549.  
Officers Air Brake Men's Association for 1907, 323.  
Packing Rings and Air Valves, 262.  
\*Piston Remover (Air Brake), 170.  
Retaining Valve Piping, 325.  
Re Transportation (Official Correspondence), 216.  
S F 4 Pump Governor, 215.  
Straight Air, Holding Power of, 25.  
Train Weight and Brake Work, 215.  
Volumes of Air, Comparative, 262.  
Apprentice Class at Jackson, 515.

## B

\*Baggage Trucks, Automobile, 185.  
Board of Trade, British, A. R. Bell, 239.  
Boilers, Injecting Water Into, 407.  
Boiler Makers' Association, 297.  
Boiler Skimmer and Blow-Off, 176.  
Book Notices:  
Air Brake Catechism, Blackall, 163.  
Balancing of Engines, Steam, Gas and Petrol, Blacksmith's Proceedings 1906, 20.  
Roller Waters, W. W. Christie, 69.  
Bridge Pier, Design of, C. Derleth, Jr., 256.  
Concrete Factories, R. W. Lesley, 209.  
Development of the Locomotive Engine, Angus Sinclair, 410.  
Electric Wiring, H. C. Hortsman and V. H. Touseley, 69.  
Historic Locomotives, A. R. Bennett, 20.  
Laying Out for Boiler Makers, The Boilermaker, 499.  
Locomotive Compounding, J. F. Cairns, 256.  
Locomotive Performance, W. F. M. Goss, 69.  
Machine Shop Work, F. W. Turner, 544.  
Master Mechanics' Assn. Proceedings, 1907, 454.  
Modern American Lathe Practice, O. E. Perigo, 163.  
Modern Steam Engineering, G. D. Hiscox, 208.  
Practical Engineering, Am. Text Book Co., 543.  
by A. Sharp, 544.  
Practical Lettering, F. F. Meinhardt, 20.  
Practical Mechanics, Jns. Powell, 256.  
Questions and Answers on the Standard Code, G. E. Collingwood, 19, 454.  
Railroad Accidents, R. C. Richards, 19.  
Railroad Curve Tables, R. S. Anderson, 20.  
Railroad Men's Catechism, Angus Sinclair, 367.  
Railroad Pocket Book, F. H. Colvin, 163.  
Random Rhymes and Rhapsodies of the Rail, Shandy Maquire, 255.  
Recipes, 20 Century Book of, G. D. Hiscox, 209.  
Six-Chord Spiral, Stephens, 117.  
Switchboards, Wm. Baxter, 20.  
The Blacksmith's Guide, J. F. Sallows, 499.  
Valve Gears and Indicators, W. S. Leland and Carl S. Dow, 499.  
Walschnerts Valve Gear, W. W. Wood, 20.  
Brazing, Hiota on, 242.  
Bridges:  
\*Early Wooden, 349.

\*Niagara Canyon Trestle, 51.  
\*Suspension at Niagara, 191.  
\*The Quebec, Fall of, 439.  
\*Tubular Bridges, 237.  
\*Zambezi River, 1.  
\*British Block Trains, A. R. Bell, 49.  
British Notes and News, A. F. Sinclair, 4, 202.

## C

\*Calculations for Railway Men, F. H. Colvin, 72, 120.  
Cars:  
\*All Steel Coach, 471.  
\*Bogle Well Wagon, Cheshire Lines, 38.  
\*English Railway, E. C. Landis, 490.  
Evolution of the, 210.  
Ferry on Lake Ontario, 545.  
\*Forty-ton Well Wagon, Gt. Nor. of Eng., 355.  
\*Hospital Car for the Erie, 13.  
\*Hudson Companies', 377.  
\*Mall Vans, S. E. & C. Ry. of England, 250.  
\*Motor Car, No. 8, Union Pacific, 180.  
\*One Hundred and Fifty Ton, Bethlehem Steel Co., 416.  
\*Private, for Western Union, 56.  
\*Rail Motor on the Gt. Northern of Eng., 289.  
\*Seventy-five Ton Flat, L. S. & M. S. Ry., 491.  
\*Steam Motor Car for Can. Pac. Ry., 205.  
\*Steel Box, for U. P., 209.  
\*Steel Dump, 112.  
\*Steel Postal, Erie, 187.  
\*Steel Suburban Motor Car, 172.  
\*Steel Underframes for Wooden, 198.  
\*Well Wagon, 40-ton, Gt. Nor. of Eng., 355.  
Chip Remover, Magnetic, 318.  
Coal of the World, 135.  
\*Coal Storge, Under Water, 174.  
Commutator, What Is a, by G. S. Hodgins, 501.  
Compound in Gt. Britain, The, 140.  
Correspondence School, 20, 71, 119, 165, 211, 257, 319, 369, 413, 457, 545, 591.  
\*Counter Electro-Motive Force, 376.  
\*Cowhairs Incline at Glasgow, 278.  
Cranes, A Word Concerning, 97.  
Cyclopd Curves, 64.

## D

Drill Press Hints, 24.  
\*Dynamos, Elementary Principles of, C. Renshaw, 127, 217, 263, 375.

## E

Editorials:  
American Railway Association, 542.  
Apprentices, Educating, 365.  
Apprentice Instructors, 254.  
Apprentices, Santa Fe to Educate, 498.  
Block Signal Report, 162.  
Board of Trade, British, 252.  
Boiler Explosion, Low Water, 206.  
Boiler Explosion, 161.  
Boiler Explosions, Causes of, 408.  
Boiler Inspection, by State, 454.  
Both Parties Benefited (N.Y.C. Apprentices), 497.  
Brother's Keeper, Am I, 252.  
Centre of Gravity, Low, 160.  
Clearing House Idea in Car Service, 66.  
Compound, Present Status of, 254.  
Conciliation, 540.  
Conventions, M.M.&M.C.B., Atlantic City, 315.  
Convention, Trav. Engineers, 452.  
Cuban Railways, 117.  
Curves, Derailment on, A Theory of, 543.  
Deflector, Adjusting the, 540.  
Derailment on Curves, A Theory of, 543.  
Driving Shoes and Wedges, 364.  
Duty of a Doctor, 68.  
Easily Made Repairs, 68.  
Educating Apprentices, 365.  
Engineemen, Help Educate, 452.  
Exhaust Pipe, Adjusting the, 453.  
Firemen, Instruction of, 367.  
Flue, Bursting, 367.  
Headman or Induna, 67.  
Heat Utilized, Small Proportion of, 541.  
Injector, The, 163.  
Inductive Reasoning, 497.  
Industrial Agreements, 115.  
Latbes, Electrically-Driven, 207.  
Lifting Appliances, 208.  
Low Center of Gravity, 160.  
Material, Fondness for Oil, 206.  
Metternich Railway, 68.  
Mechanical Stokers, 512.  
Motor, Railroad, High Speed, Gasoline, 409.  
Patent Office, Needs of the, 18.  
Patents, Thriving on, 314.  
Pennsylvania Railroad Tubes or Tunnels, 69.  
Piston Rings, Fitting, 496.  
Practices, Wasteful, 540.  
Organization, Power of, 114.  
Railroad Appliances, Life of, 543.  
Railroad Investigation in Germany, 115.  
Railroad Legislation, 207.  
Railroad Motor, High Speed, Gasoline, 409.  
Railroads, Condition of, 453.  
Railroads, Stenling from, 541.  
Rails, Breakage of, 315.  
Rails, Composition of, 367.  
Rails, Nickel and Uncertain Material for, 406.  
Rails, Strength and Weakness of, 452.  
Railway Association, American, 542.  
Railways, Profits of British, 317.  
Railway Service, 161.  
Railway Service, 366.  
Reading, Acquiring Value by, 453.  
Reasoning, Inductive, 497.  
Red Snow, 19.  
Reductions, Reasons for, 543.  
Risk of the Trade, The, 16.  
Rules, Infraction of, 364.  
Safety Appliances Exhibition, 116.  
Safety is a Staple Article, 160.  
Santa Fe to Educate Apprentices, 498.  
Scottish Railway Disaster, 117.  
Sector, Setting a New, 208.  
Security, Museum of, 115.  
Signaling, Instruction in, 408.  
Shoes and Wedges, Driving, 364.  
Silde Valves, Leakage of, 18.  
Smoke Prevention, 498.  
Smoke Prevention, Limitations of, 253.  
Soft Hammers, 69.  
Speed, Judging and Knowing, 163.  
Stokers, Mechanical, 542.  
Superheating, The Why of, 496.  
Surprised Tests, 67.  
Technical Education of Apprentices, 116.  
Tests, Inconclusive, 366.  
Train Protection, So Called, 17.  
Trainmen, Promote, to Higher Positions, 315.  
Travelling Enginemen's Convention, 452.  
Throttle Valve, Fitting a, 316.  
Time Table Advertising, 19.  
Utilized Heat, Small Proportion of, 541.  
Valve, Fitting a Throttle, 316.  
Valve Gear, Walschaerts, 409.  
Wasteful Practices, 540.  
Wilmarth, Seth, 315.  
Work Shop Words, 315.  
Effort, Individual, H. Emerson, 343.  
Electrical Articles.  
Commutator, What Is a, by Geo. S. Hodgins, 501.  
Conductivity and Resistance, 264.  
Controller, the Electric, by W. B. Kouwenhoven, 545.  
Counter Electro-Motive Force, 376.  
Fuses in Electrical Circuits, 79.  
Heat Electrically Produced, 79.  
What Is a Watt? by Geo. S. Hodgins, 171.  
Motors for Railway Service, 325.  
\*London's Latest Tube (Picadilly), 326.  
Electrical Induction, by Geo. S. Hodgins, 457.  
\*Electricity in Railroad Shops, 419.  
Electrical Laws and Units, 263.  
Electric Light, to Cheapen, 128.  
\*Electric Locomotive, K. C. & W. Belt Ry., 127.  
\*Electro-Magnetism, by Roger Atkinson, 29, 78.  
\*Electric Measuring Instruments, 421.  
\*Elementary Principles of Dynamios, by Clarence Renshaw, 127, 217, 263, 375.  
Electricity Replaces Steam, 218.  
Electrical Terms, 75.  
Electrical Units, by Roger Atkinson, 127.  
Electric Air Compressor, 76.  
Electrical Controller, The, 545.  
Engineers, Eminent, 458, 522.  
\*Electrical Dept., 28, 78, 127, 171, 217, 263, 325, 375, 419.  
Electrical Induction, 457.  
Electrical Laws and Units, 263.  
Engine Failures, 302.  
Electro-Magnetism, R. Atkinson, 28, 78.  
\*Electric Night at the N. Y. Club, 182.  
Electrical Terms, 75.  
\*Electric Traction, Heavy (N. Y. Club), 182.

Engineering Societies Building, 236.

## F

Fitting Main Rod, 126.

## G

\*Gasoline Weed Burner on the Union Pacific, 556.  
\*General Correspondence, 9, 59, 107, 153, 190, 245, 307, 357, 401, 445, 489, 533.  
General Foremen Association, 186, 272, 279, 304, 362, 378.  
\*Guatemala Central, Facts about, 247.  
\*Gyrostat and Mono-Rail, 360.

## H

Harnessing Victoria Falls, 90.  
Head Work in Little Things, T. Toot, 491.  
High Steam Pressure, 80.  
Hudson Companies' Tunnels, 64.  
\*Hydraulic Ram, 529.

## I

\*Ideal Track, 88.  
Individual Effort, H. Emerson, 343.  
\*Interesting Relic, 46.

## J

Judgment of a Child, 140.

## L

Locomotives:

\*Am. Loco. Co. Soo Line 2-6-2, 353.  
\*Am. Loco. Co., W. & D. 4-6-0, 311.  
\*Am. Loco. Co. 2-6-0 for Mexican Central, 35.  
\*Am. Loco. Co. 2-6-0, Vandalia Line, 175.  
\*Am. Loco. Co. 4-4-0 Passenger for Japan, 58.  
\*Am. Loco. Co. 4-6-0, C. & N. W., 251.  
\*Am. Loco. Co. 4-6-0 Rogers, C. of P., 195.  
\*Am. Loco. Co. Tank Engine, Nevada Northern, 113.  
\*Am. Loco. Co., A. & W. P. 4-6-2, 511.  
\*Am. Loco. Co., C. & O. 2-8-0, 441.  
\*Am. Loco. Co., Erie, Angus Articulated Mallet, 421.  
\*Am. Loco. Co., Mallet Compound, Cen. of Brazil, 531.  
\*Arstian Rail Motor Engine, 499.  
\*Baldwin C. & S. 4-6-0, 483.  
\*Baldwin G. H. & H. R. R. 2-6-0 Oil Burner, 468.  
\*Baldwin 4-6-0 Engine for Italy, 81.  
\*Baldwin Mo. Pac. 2-8-0, 535.  
\*Baldwin T. & P. 2-8-0, 405.  
\*Baldwin 2-6-0 for China, 205.  
\*Baldwin 2-8-2 Simple, Woodward Iron Co., 118.  
\*Baldwin 2-10-2 Simple, P. S. & N., 151.  
\*Baldwin 4-4-2, So. Pac., 244.  
\*Baldwin 4-6-2, C. of G., 7.  
\*Baldwin 4-6-2 Comp., for Mexican National, 103.  
\*Baldwin Six-Wheel Switcher, D.S.S.&A., 214.  
\*Baldwin A. C. L. 4-6-0, 277.  
\*Baldwin Western Pacific 2-8-0, 329.  
Compound, Present Status of, 254.  
\*Dutch State Express, 222.  
\*Electric Locomotive, K. C. & W., Am. Loco. Co. and G. E. Co., 127.  
\*Electric Locomotive used in the Simplon Tunnel, 148.  
\*Electric Switcher, Am. Loco. Co. and G. E. Co., 28.  
\*German Tank Engines, 105.  
\*Illinois Traction, Electric, 172.  
\*Japanese 4-4-0 Engine, 70.  
\*Lima Geared for C. & O., 427.  
Montreal Loco. Co., 4-6-0, T. H. & B., 260.  
\*Oldest Canadian, "Samson," 500.  
P. L. & M. Compound 4-4-2, 489.  
Rail Motor Engine, 204.  
\*Royal Palatine Ry., 4-4-2, J. A. Maffel, Munich, 449.  
\*Swiss, 201.  
\*Tank 4-6-4, So. African, 197.  
\*W. & M. Old "Lion," 492.  
\*Central of Georgia 2-8-0, 368.  
\*Gt. Eastern of England 0-8-0, 335.  
\*Italian 4-6-0 Compound, 287.  
\*L. & N. W. Ry., 4-4-2 Tank, 380.  
\*Matheran 0-6-0 Radial Axle, 383.  
\*Rail Motor on Gt. Northern of Eng., 289.  
\*Slamese 2-6-0 Wood Burning, 356.  
\*Westphalia, 0-10-0 Tank, 356.  
Locomotive Building, Early, 394.  
\*Baldwin, De Glehn Compound 4-6-0, 395.  
\*Locomotive Design, Curiosities of, Angus Sinclair, 398, 441, 487, 495, 537.  
Locomotive, Pooling of, by D. R. McBain, 559.  
Locomotive Superheaters, 41.  
\*Locomotive Testing Plant, Penna. R. R., 274.  
\*London's Latest Tube, 326.  
Locomotive, Pooling in General, D. R. McBain, 559.  
London Underground, 82.

## M

\*Matterhorn Railway, 269.  
\*Motive Power of the Lehigh Valley, Angus Sinclair, 30.  
Machine Moulding, 515.

\*Mechanical Stoker on the Erie, 219.  
Mechanical Stokers, 361.  
Momentum, 555.  
\*Mono-Rail and Gyrostat, 269.  
\*Motors for Railway Service, 325.  
\*Mountaineer, The Modern, 299.

## O

Obituaries.  
Sir Benjamin Baker, 271.  
Charles Haynes Haswell, 272.  
Richard D. Hurley, 558.  
Edmond Parker Lord, 271.  
James Macbeth, 382.  
Charles E. Main, 470.  
Michael James Penderghast, 558.  
George Richards, 558.  
Samuel Spencer, 34.  
John A. Walker, 271.  
Jasper Wandle, 133.  
James N. Weaver, 178.  
Oil, Square Deal in (S. F. Bowser Co.), 340.  
Old Colony R. R., Opening of, 470.

## P

\*Palace, A Floating (S.S. Lusitania), 450.  
\*Parallelogram of Forces, by Geo. S. Hodgins, 22.  
\*Patent Office Dept., 6, 65, 104, 164, 196, 273, 322, 396, 463, 507, 551.  
307, 357, 401, 445, 489, 533.  
Personals, 33, 83, 131, 177, 223, 269, 321, 381, 425, 469, 513, 557.  
Physical Science, Elements of, 211, 258, 320, 370, 414, 457, 502, 547.  
Piccadilly Tube (London), 326.  
Pooling, Locomotive, D. R. McBain, 559.  
Portraits.  
Ball, H. F. Vice Pres. Am. Loco. Co., 177.  
Daniels, Geo. H., of the N. Y. C. & H. R., 269.  
Drury, M. J. Mech. Supt. A. T. & S. F., 33.  
Fay, E. F. Gen. Foreman Union Pacific, 271.  
Finley, W. W. Pres. Southern, 33.  
Forney, M. N., 381.  
Kennedy, Jas. Vice Pres. Ry. & Loco. Eng., 131.  
McCrea, Jas. Pres. Pennsylvania, 83.  
Montgomery, Hugh. S. M. P. Bangor & Aroostook, 269.  
Spencer, Samuel (deceased), 34.  
Swan, C. A., Jr. Gen. Foreman, Hicks Loco. Works, 271.  
Wandle, Jasper (deceased), 133.  
Wildin, G. W. Mech. Supt. N. Y., N. H. & H., 381.  
\*Post Cards, Patent Pictorial, 532.

## Q

Questions Answered, 23, 73, 121, 167, 213, 258, 321, 371, 415, 459, 503, 547.

## R

Railroading as a Business, 62.  
Railroad Equipment in the U. S., 63.  
\*Railroad Equipment, Increase in, 317.  
Railway Extension in Canada, 48.  
Railroad Men, Among the, by Jas. Kennedy, 511, 528.  
\*Railway Service, Motors for, 325.  
Railroad Shops, Electricity in, 419.  
\*Rotary, Snow Plow in the Rockies, 99.

## S

Scale, Heat Losses Due to, 432.  
\*Scientific Invention Practically Applied, 62.  
Screw Cutting, A Lathe Gearing for, 166.  
Shop Appliances, Methods and Tools.  
\*Air Compressors (Franklin), 333.  
\*Air Device for Cylinders, 534.  
\*Air Hammer, N. Y. S. & W. Shop, 308.  
\*Air Operated Vise, 403.  
\*Air Pump Pistons, Lathe Attachments for, 358.  
Automatic Drill Grinder (Dahl), 43.  
\*Band Resaw, New (Fay & Egan), 293.  
\*Band Scroll Saw, Fay & Egan, 230.  
\*Band Scroll Saw (Fay & Egan), 386.  
\*Band Rip and Edging Saw (Fay & Egan), 563.  
\*Bell Ringer, Air, 110.  
\*Chicago Midget, 92.  
\*Cook Track Drill, 231.  
\*Crank Pin Machine, Portable, 200.  
\*Cutter for Slide Rod Holes, 430.  
\*Cylinder Covers, Grinding, 357.  
\*Cylinder Packing Quickly Made, 401.  
\*Dome Shaped Headlight, 534.  
\*Doors, Wooden Rolling, 232.  
\*Driving Brass, Removable, 518.  
\*Eccentric Rod Bender (Erie), 451.  
\*Eccentric Rod Twister (Erie), 451.  
\*Echelon and Juxtaposition, 27.  
\*Equalizer, Safety Hanger for, 200.  
\*Fire Bucket (Wagoner), 391.  
\*Flexible Connections (Bordo), 385.  
\*Flag Socket Crane, 534.  
\*Frame Repairs, W. McIntosh, 199.  
\*Gauge Cock, Double Seated, 347.  
\*Grease Moulder, 256.  
\*Handy Drill for Tight Corners, 48.

\*Hard Work Well Done (King Lawson Dump Car), 564.

\*Holst, Electric, for Shop, 228.  
\*Hold Fast Grease Cup Plug, 562.  
\*Hollow Chisel Mortising Machine (Fay & Egan), 474.  
\*Hose Coupling (Thor), 340.  
\*Iron Wedge and Table Lock, 108.  
\*Just a Hammer, 93.  
\*Locomotive Fine Blower, 50.  
\*Lubrication, Force Feed (McCord), 427.  
\*Made as Used (Gold Car Lighting System), 561.  
\*Metal Marker Flags, 536.  
\*National Steel Tube Cleaner, 49.  
\*Nut Lock and Swab, 156.  
\*Oil Furnace, Portable (Ry. Mat. Co.), 477.  
\*Packing Ring Chuck (Erie), 342.  
\*Pipe Threading and Cutting Machine, 29.  
\*Pipe Threading Machine (Stove Fndy. Co.) 560.  
\*Piston Ring Mandrel, 537.  
\*Piston Rod Puller, 27.  
\*Rod Lifting Attachment, 403.  
\*Self Grinding Valve (Swenson), 344.  
\*Shop Kink Prevents Kinks, 82.  
\*Slotter Tool, Twice as Fast, 50.  
\*Smoke Jack, Fireproof, 129.  
\*Smoke Stack, Wallace, 475.  
\*"Stay-tight" Fire Hoe (T. Toot), 491.  
\*Stuffing Box, Trottle Improved, 155.  
\*Switch Closer, Automatic, 130.  
\*Tool Holder, Armstrong Bros., 186.  
\*Train Lighting by Electricity, 518.  
\*Valve Bushing Boring Device, 310.  
\*Valve Setting Machine on Erie, 227.  
\*Valve Stem Clamp, 156.  
\*Wallace Smoke Stack, 475.  
\*Water Glass Guard, 106.  
Shop Betterment, 285.  
\*Signals on Pennsylvania, 406.  
Signalling, Problems in, 281.  
Smoke Stack, Fitting a, 426.  
Sound, Observations on, by Geo. S. Hodgins, 293.  
Steam Boilers, Angus Sinclair, 52.  
Steel Making, 101.  
Stores Department, The, 328.  
Steel as an Engineering Material, W. S. Standiford, 301.  
Steel Rails, 15.  
\*Stoker, Mechanical, Erie, 219.  
Stories and Sketches:  
Billy's Cat, 275.  
Billy's Thermometer, 194.  
Ceeli Scores a Point, T. Toot, 352.  
Haste to Save the Work Train, 55.  
Holy Terror in Jim Skeevers' Hands, by J. A. Hill, 526.  
\*Honeymooning on the Lehigh, 168.  
Jim Skeevers and a Gentleman, John A. Hill, 57.  
Markam and Close Did Something, F. H. Colvin, 95.  
O'Hoolihan Saves His Half Day, E. J. Mack, 45.  
Railroading Under Difficulties, Sam Rarus, 329.  
Reminiscences of an Old-Timer, Shandy Maquire, 148.  
Shaw's Closet, 422.  
\*The Object Lesson of the Chair, A. O. Brookside, 8.  
\*Weary Willie, Blacksmith, T. Toot, 142.  
\*Snow Plow in the Rockies, Rotary, 99.

## T

\*Testing Plant for Locomotives, Penn. R'd, 274.  
Therby vs. Practice, 152.  
\*Track Insulation on a Bridge, 136.  
Trade, British Board of, A. R. Bell, 239.  
Trains:  
\*Black Diamond on the Lehigh, 527.  
\*Bombay-Poona Mail, 481.  
\*Fast in America, N. Y. C., 394.  
\*Hook of Holland Express, 159.  
\*Pennsylvania Special, 437.  
\*20th Century Limited, 394.  
\*Train Control, Automatic, 266.  
Train, First Dispatcher, 130.  
Transportation and Adv. Space, 407.  
Travelling Engineers' Convention, 455, 484, 552.  
Ton-Mile-Per-Hour, 245.  
Tonnage Rating of Locomotives, 138.  
Tunnels at New York, Penna. R. R., 318.  
Tubes, Corrugated, 407.  
\*Tunnel at Detroit, Subaqueous, 411.  
\*Tunnel, Floating a Railway, 495.  
\*Tunnel, The Great (Simplon), 145.

## U

Unquenchable Stone, 70.

## V

Valve, Cylinder Relief, 129.  
Valve Gear, Adjusting, Stephenson, 110, 178.  
Varnish, 157.

## W

\*Weed Burner on the Union Pacific, 556.  
What is a Watt? By Geo. S. Hodgins, 171.  
Wheels, Chilled Cast Iron, 268.  
Wrong Statements vs. Accuracy, 14.

# Railway and Locomotive Engineering

Copyright by Angus Sinclair Co.—1906

A Practical Journal of Railway Motive Power and Rolling Stock

Vol. XX.

136 Liberty Street, New York, January, 1907

No. 1

## Zambesi River Bridge.

The Cape-to-Cairo railway is the popular designation usually given to a great transportation undertaking, rather than the actual name of any one transcontinental line. A road is now in operation be-

railway of 3 ft. 6 ins. gauge. These two lines of communication stretching out toward each other, make in all about 3,065 miles, leaving at present about 2,500 miles yet to build. The magnitude of the undertaking may be appreciated when it is re-

ritory or in British protectorates, reaching from north to south through the dark continent.

The grandest piece of engineering work on this road was the erection of the great steel arch across the deep gorge of the



STEEL ARCH OVER THE ZAMBESI RIVER ON THE CAPE-TO-CAIRO RAILWAY.

tween Cairo, the capital of Egypt, and Khartoum, the seat of government for the Soudan Provinces. This line practically follows the course of the Nile and is 1,335 miles long. The road from Cape Town, at the extreme southern extremity of Africa to the Broken Hills, a distance of 1,730 miles north, has been built, and is a

membered that although more than half the line has been built, there yet remains a portion to be constructed, equal in length to the full width of the United States. The work is being steadily carried on, and in time there will be unbroken rail communication, probably over 5,500 miles in extent, almost wholly within British ter-

Zambesi river. This bridge is similar to the one over the Niagara river, which was described and illustrated in RAILWAY AND LOCOMOTIVE ENGINEERING for December, 1906. The Zambesi bridge is in the form of a spandrel-braced arch standing on two hinges at the abutments, and the lower chord of the arch is a parabolic

204781

curve. The bridge is situated about 700 yards below the famous Victoria Falls, which is 1,631 miles from Cape Town. The site of the bridge is believed to have been the position occupied by the falls in prehistoric times. This structure is therefore not only interesting from an engineering point of view, but it thus indirectly points to a profoundly interesting geological conjecture.

The top chord of the bridge is not a perfectly horizontal line. At a temperature of 60° F. it has a camber of 9 ins. and the height above the average water level is 383 ft. The bridge itself is 15 feet deep at the centre, and the versed sine or depth of the arch is 90 ft. The abutments are about 277 ft. above the water level and are built upon the solid rock of the banks. The arch is 500 ft. span, and there are 20 panels each 25 ft. wide. At the ends of the arch there are connecting spans made in the form of ordinary lattice girders, the one at the north end being 87½ ft. long, and the one at the south, 62½ ft. This makes the length of the whole structure 650 ft. The width of the bridge measured at the abutments is 53 ft. 9 ins., centre to centre. At the top, it measures 27 ft. 6 ins., while it is 30 ft. wide at the parapet or cross girders, upon which the bridge floor is carried. The gauge of the railway being 3 ft. 6 ins., there is thus room for a second track when it is required. The weight of the bridge is 1,650 long tons, or 1,848 tons of 2,000 lbs.

The design and specifications being furnished by their engineers, Sir Douglas Fox and Partners of Westminster, and Sir Charles Metcalfe, Bart. The design was made by Mr. G. A. Hobson, one of the partners in the Fox firm, and is altogether a masterpiece of bridge engineering.

It has been stated that the bridge was of the cantilever type, but this refers to its mode of erection, as it was built out from both sides at the same time, as a cantilever bridge is built, and without false works of any kind. The cantilever principle as used in the erection of steel arch bridges was referred to in our December, 1906, issue, and this method was followed in the case of the Zambesi river bridge. While being erected, each half arch was practically a cantilever hinged at the abutments, and it was not until the final pieces were put in position at the crown of the arch that the bridge became self sustaining.

The method of holding up the half arches as they grew and increased in weight day by day had been provided for in the design, and was cleverly accomplished by Mr. A. C. Imbault, who was

ed ends saddles were held, each by a pair of deep nuts. Steel cables having a tensile strength of 100 tons per sq. in., and 1 in. in diameter, were firmly held in the saddles. These cables were carried inland



THE CAPE-TO-CAIRO RAILWAY AS IT IS TO-DAY.

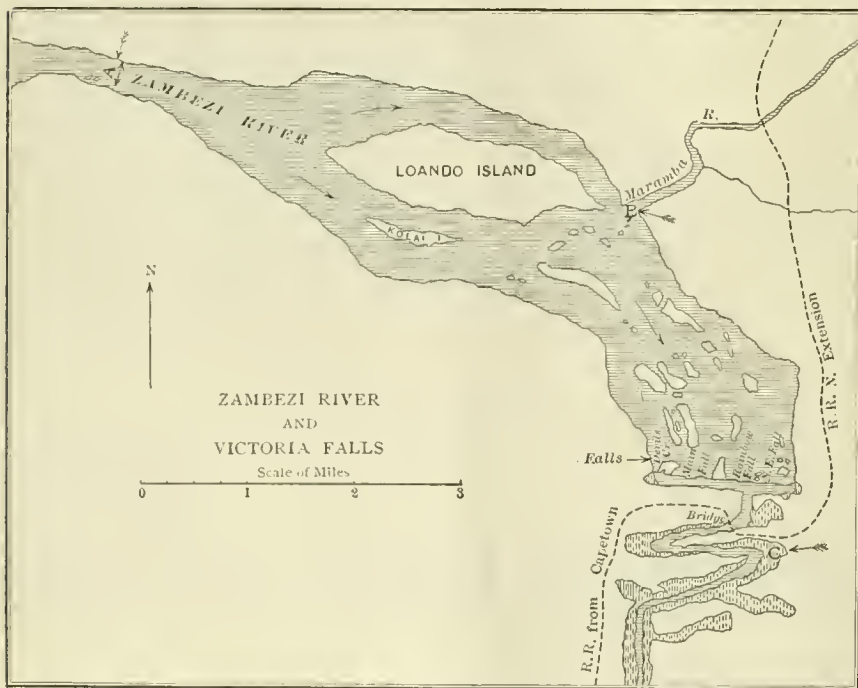

MAP OF THE VICTORIA FALLS SHOWING POSITION OF THE RAILWAY BRIDGE.

each. The cost of the bridge was about £70,000 or equal to about \$340,000 of our money. The contract for this bridge was given to the Cleveland Bridge and Engineering Company, Ltd., of Darlington, England, by the Rhodasia Railways, Ltd.

engineer in charge of the work for the contractors. The upper end of the vertical shore posts were provided with long steel pins 7 ins. in diameter. Around these pins U-shaped pieces of iron were placed, and near their thread-

to the anchorage.

Following one of these cables, we may say that the shore end was drawn along the bank some distance and the end was passed down a sloping tunnel cut in the rock about 30 ft. long. At the bottom of this tunnel or shaft a horizontal tunnel at right angles to the first, was driven through the rock for about 30 ft. and at the far end an inclined shaft, similar in slope and direction to the first, lead up to the surface. The entrance to the inclined shafts and the right angles made by the cross shaft were rounded out so that when the cable was drawn down the first, through the second and up the third shaft, it did not encounter rough or projecting angles of rock. The end of the cable having been threaded through these rock-hewn shafts, was fastened to the upper end of the adjacent shore post of the bridge by a U-shaped piece enclosing a 7-in. pin, similar to the first connection. Our illustration shows the method of anchoring, but for the sake of clearness, only three cables are represented.

A large number of these cables were thus attached and passed through the rocky shafts which formed the anchorage. The plan of the anchorage may be said to have resembled in shape the form of a staple used to hold a stake pocket to the side of a flat car, the free ends of the staple corresponding to the sloping shafts, the connecting shaft being perhaps 10 or 12 ft. below the surface of the rock. The rock forming the banks of the Zambesi is hard, heavy and dense and made an excellent anchor for the cables. On the surface of the rock between the inclined

shafts about 400 tons of rails were laid to prevent any danger of the rock breaking out, and to make assurance doubly sure. On each bank the pair of half arches was thus literally sewed to the shore as one might sew a two-hole button to a stiff piece of leather by passing

air, backward and forward over the abyss below, was nicknamed "Blondin" by the workmen, after the famous tight rope performer, who a generation ago, walked three times across the Niagara gorge on a single wire rope. During the progress of the work an enormous net, such as Blondin would have scorned to use, was spread out flat like a giant's hammock below the workers on the bridge. This was in fact a huge safety device and was for the purpose of catching any tools or small parts of bridge material, or indeed any human being unlucky enough to fall from the lofty structure, for certain it is that the turbulent river below would never have yielded up body of man or bar of steel, had either chanced to drop from that dizzy height. Fortunately, no one fell into

gigantic fissure, cleft between sheer walls of basalt rock, more than 400 ft. deep. The river is calm above the precipice and flows down a gentle slope to the brink, the trees on the rocky islands which hang on the very edge are reflected in the smooth water. Then, without tumult of rapids, one might almost say, without warning, the awful plunge is made. Such is the Victoria falls of the Zambesi. The discovery of this, the largest and most wonderful waterfall in the world, was made by Dr. Livingstone in 1851. Compared with Niagara, this fall is more than half as wide again and two and a half times as high.

The gulf between the vertical walls of rock, which forms the crack in the earth's surface into which the river tumbles, is something more than a mile long and less than 300 ft. wide. It is believed to have been formed by some mighty earthquake in the days when the earth was young. In this narrow gorge the water foams and boils toward its outlet near the eastern end. The whole of the mile-wide river above the fall, becomes a turbulent stream below, and running, one might almost say, on its edge, surges out of the gulf through a rocky channel about 325 ft. wide, on its way to the Indian ocean.

An old description of this world wonder tells of the clouds of spray which come up from out the chasm. It speaks of the great masses of watery vapor which mount a thousand feet in air and drift off and



METHOD OF ANCHORING THE HALF-ARCHES.

the thread through, the return stitch being made a short distance from where the needle first entered.

The alignment or the raising or lowering of the top chords of the bridge were easily effected by tightening or loosening the nuts on the saddle pieces in which the cable ends were made fast. The large number of cables which were used distributed the pull, each strand doing its own share of work like the threads by which the Liliputians bound the giant Gulliver, and made him captive by their united strength.

The pull on each set of cables holding a half span of the bridge, just before the arches were finally closed, has been estimated at more than one million, six hundred thousand pounds. To picture to ourselves what such an enormous stress would be like, if the bridge, resting on its hinged supports at the abutments, had been held in position by weights instead of sustaining cables anchored in the rock, we would find that it would have required four monster locomotives, such as the Erie railroad Mallet compounds, each weighing 410,000 lbs. without their tenders, and all four hung on a string to balance one half the bridge, just before what may be called the keystone pieces, were put in place.

The bridge, as we have said, was built out from each side at the same time, and stands on four hinge pins on the abutments. The transference of material across the gorge so that both sides could be built at the same time was effected by an aerial telfer, the car being carried upon a steel cable 870 ft. long, which was suspended from towers, one on each bank. The car and driving mechanism weighed about 5 tons and was capable of carrying a load of 10 tons. The car, operated by electricity, making its way daily high in

it, and though the net was placed there to give the men confidence, many of them, with the contrariety peculiar to human nature, complained that it made them nervous.

The Zambesi river, the fourth in point of size in Africa and more than 1,000 miles long, drains an area about equal to one-fifth of the United States. There is on this river, as we have said, near the site of the railway bridge, the most



LUXURIANT VEGETATION EVERYWHERE SURROUNDS THE BRIDGE.

remarkable cataract. Fancy what is practically a tranquil lake, more than a mile wide, with one end smoothed away, so that the whole volume of water pours over a perpendicular ledge, in two majestic sheets, and falls into a

break in copious showers which nourish a luxurious vegetation for miles around. On the opposite bank green trees grow whose leaves are ever wet, and the ceaseless drip forms tiny rills which in flowing down the steep sides of the narrow gulf

are caught up again by the uprush of vapor and carried far on high.

The rocky islet looking like a garden in mid-stream is now called Livingstone island, and divides the Main fall to the west from the Rainbow fall to the east. This latter fall has been estimated as being 1,858 yards wide, and the Main fall at 546 yards wide. At each end there is a smaller fall cut off by islands. These falls are called respectively the Eastern Cataract and the Cascade or Devil's Creek fall. The Main fall is separated from the Cascade by Buka island, which like Livingstone island is covered with verdure. The native tribes about the Zambesi called the whole great fall by the poetical name of the Mosi-oa-Tounya, or the Thunder-sounding Smoke, on account of the masses of vapor which continually ascend and on account of the roar of the waters. It was this same elemental feeling of reverence in the presence of the mighty forces of Nature, common to the whole human race, which caused the North American Indian to look with awe upon the cataract at Niagara as the abiding place of the spirit of the thunder.

#### Block Signals for the B. & M.

A recent press from Concord, N. H., says: "General satisfaction is felt here over the recent announcement of the Boston & Maine Railroad that it will equip its line from this city to Boston with the automatic block signal system. The work, it is said, will involve an expenditure of about \$700,000. In addition to the line from here to Boston, the new system will

#### British Notes and News.

By A. F. SINCLAIR.

##### ELECTRIFICATION OF SWEDISH ROADS.

An interesting report has been issued on the subject of utilizing the great wealth of water power which Sweden possesses for the operation of her railways and for other purposes. The first object of the inquiry was to assess the cost of working the whole of the railways in the country by water power, but the calculations showed that whereas operation by steam power costs £374,000, electric working would run up to about £750,000 per annum, rendering electric traction, even from natural power, an impossibility from an economic point of view. That was the case if the whole system was electrified, but if only a portion of the lines, those best adapted for the purpose, were transformed, it appeared that the project might be made profitable, provided the difference between the average and the maximum power required, about 33,600 h. p., could be disposed of for agricultural or industrial purposes. This portion extends to about 560 miles. A larger project consists of a scheme for the utilization of the falls of the rivers in central Sweden as a source of power for various purposes, with the railways as possible customers, along with towns, for power and lighting purposes, while agricultural and

would, of course, depend on the outlet being sufficiently extensive. The scheme would cost about £4,700,000, and would carry an annual expenditure of about



VICTORIA FALLS FROM AN OLD WOOD CUT IN THE "WORLD OF WONDERS."

£650,000, and by proper combination, with the support of the railways profitably accessible, the project appears to have all the elements of success.

##### GOOD EQUIPMENT MAKES FOR SAFETY.

Some months ago, while a passenger train from London to Manchester was passing through a tunnel at full speed, a rail broke, the line spread, and all the train, excepting the engine and tender, was derailed, but no one was hurt. The rails were 86 lbs. to the yard when laid, but through wear had fallen to 76 lbs. after between seven and eight years' use. The most of the train was lit by gas, the front and rear vehicles only by electricity. The gas was extinguished by the accident, but, being turned on at the burners, there was a great escape, which in an enclosed space might have led to an explosion, but for precautions taken by an inspector who happened to be on the train. The front vehicle electric light did not go out, and was of the greatest use in the indescribable confusion which ensued. The train was coupled throughout with heavy automatic couplings, except a slip-brake vehicle at the rear end. The automatic couplings held the train intact, except the brake van, which broke away and fouled the up line of rails. A freight train entered the tunnel from the opposite direction immediately after the accident, but was stopped by a fog signal hastily



THE STEEL ARCH PHOTOGRAPHED ON A LEVEL WITH THE TOP CHORD.

include that between Boston and Portland and between Boston and Fitchburg. The system will be in working order within the year."

industrial concerns, as well as private individuals, would be provided with light and power cheaper than it is possible to produce them by other means. That scheme



placed on the rail by the driver of the passenger train. The freight engine stopped just short of the brake van so that had the other cars broken away and fouled the up line there must have been a serious accident. The moral of this story appears to be that a flaw in a rail may take seven years to show itself, and may wait till old age brings weakness to effect its purpose. Also, the electric light is more reliable, as well as being safer than gas; and automatic couplings, combined with a substantial spring vestibule between the cars, give a solidarity to the train of the greatest value in keeping it together when an accident occurs. The train was going over 60 miles an hour when the accident happened, and traveled 450 yards over the ties before being brought to a standstill; yet the damage consisted mostly of broken axle boxes, and the railway chairs by which the rails are attached to the ties. Beyond some cases of severe shock, none of the sixty passengers suffered seriously.

#### NUMBER OF BRITISH LOCOMOTIVES.

A return of the number of locomotives and motors in use on the twenty-four principal railways in the United Kingdom—except Scotland—appeared recently, and some of its salient features may be worthy of notice. The total number of locomotives is 18,017, and of motors of various kinds, 536. The Midland Railway leads the way with 2,700 locomotives, but it makes a poor showing with two motors, both steam rail carriages. The London & North Western Railway Company possesses 2,560 locomotives and three motor carriages. The other railways possessing two thousand or over are the Great Western, with 2,355, and the North Eastern, with 2,000 exactly. Of motors, the London undergrounds—the Metropolitan and the Metropolitan District—have 254 between them, but these are merely electric cars run in the trains in the usual way. A curious point comes to light in connection with the Great Central Railway, which hires 109 locomotives from the Railway Rolling Stock Trust, Ltd. The return goes to show that while the additions by the several companies to their locomotive plants during the second half of 1905 were but small, the number of motors of various styles and forms of power has been largely augmented. It is to be observed also that the motor vehicles are mostly in possession of the small companies or the big railways doing a large passenger carrying business.

#### STEAM VS. ELECTRICITY.

An interesting contribution to the discussion of this subject has been provided by an official of the North Eastern Railway of England. Lecturing before the York Railway Institute, Mr. G. Beharrell indicated the enormous growth of electric traction by the statement that whereas in

1896 third-class passengers carried on the railways of the United Kingdom exceeded those carried on tramways by 126 millions, in 1904 the tramway passengers were in the majority by 900 millions, and he was of opinion that, although a part had been at the expense of railways, the vast majority was a new form of traffic created by the cheapness of electric traction. Going into the question from his own company's experience on their Newcastle-Tynemouth branch, and that of the Lancashire & Yorkshire Railway Company on their Liverpool-Southport line, it appeared that electric haulage had resulted in increased receipts, power from a central source instead of on each train, acceler-

nomically possible in Britain. But in the case of short distance heavy freight traffic experience of some American railways showed that when current could be obtained cheaply the use of electric locomotives was worth a trial.

The work of straightening the curves and eliminating the grade on the three miles of the right of way of the Big Four, which was begun a year ago through the south edge of Danville, and has cost \$500,000, is now about one-half done and fully another year will be necessary to finish the work and the expenditure of another \$500,000.—N. Y. Commercial.



THE RAINBOW FALL LOOKING FROM LIVINGSTONE ISLAND.

ation of service, greater speed and that independent of weight of train, a more frequent service, less rolling stock, more efficient lighting and heating, a cheap form of power available at all stations, and the absence of smoke, sparks and cinders. On the other hand, he was of opinion that the system was only economical where a frequent service of trains was required, and for that reason the electrification of main lines was not at present eco-

On Nov. 11, a Seoul-Fusan train jumped the track near Su-wun, and there was a lively time in the third-class car. Our reporter graphically says that "all the hats of Coreans were broken. Two of them smoked with long pipes, so their pipes stung the smokers' necks and nearly were to be died. Some of their heads were and some faces were wounded therefore there was plenty of blood in that train."—Corea Daily News.

### Patent Office Department.

We have deemed it proper to comment on the conduct of the Patent Office at Washington from time to time, but as the subject has assumed serious proportions our comments this month take a place in our editorial columns. We are pleased to find that the evils which our inventors labor under are finding other champions besides RAILWAY AND LOCOMOTIVE ENGI-

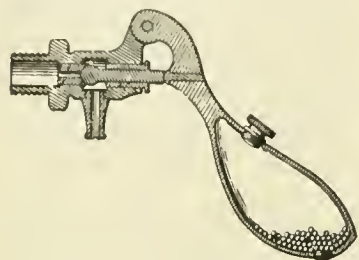

WEIGHTED GAUGE COCK.

NEERING who are willing to join us in an effort to better the Department.

Boilers and their attachments continue to be a favorite theme for our inventors to exercise their ingenuity upon, and the selections we make this month are all worthy of the consideration of those engaged in locomotive construction.

#### GAUGE-COCK.

Mr. A. C. Calder, Richmond, Va., has secured a patent for a combined gauge-cock and safety-valve. No. 835,056. The contrivance embraces a threaded body adapted for inserting in a boiler head, the body formed with a chamber with longitudinal passages extending from the chamber to opposite ends of the body, and a discharge-nozzle extending from one side of the chamber. There is also a valve in the chamber adjusted to a valve seat and having a stem extending outwardly through the body and a gravity lever connected with the body and bearing against the outer end of the valve stem.

#### OIL CUP.

Mr. J. R. Dean, Randolph, Mass., has patented an improved oil cup or lubricator. The device embraces a combination with the oil chamber provided with a valve seat in the oil passage, a toothed rack outside of the chamber, a shaft attached to the valve stem, a pinion in the shaft and adapted to mesh with the teeth of the rack, and a handle for operating the pinion, the combination forming a substantial and reliable lubricator.

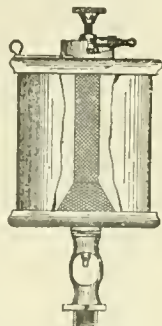

OIL CUP.

#### THROTTLE VALVE.

A throttle valve has been patented by Mr. C. C. Fawcett, New Albany, Ind. The device comprises a valve casing hav-

ing cylindrical sections at opposite ends thereof, and having annular grooves in the inner walls of the cylinder sections a short distance from their outer ends, and having ports at one end leading from one of the annular grooves into the valve casing, and having other ports at the opposite end with similar grooves, and a piston valve arranged within the valve casing and forming spaced piston heads arranged at distances apart to correspond with the distance between the annular grooves.

#### STUFFING BOX.

An improvement in stuffing boxes has been patented by Mr. J. M. Juhler, Spreckels, Cal. No. 834,984. As will be seen in the accompanying illustration, the combination takes the usual form of a longitudinally movable rod, of a stuffing box surrounding the rod and forming a

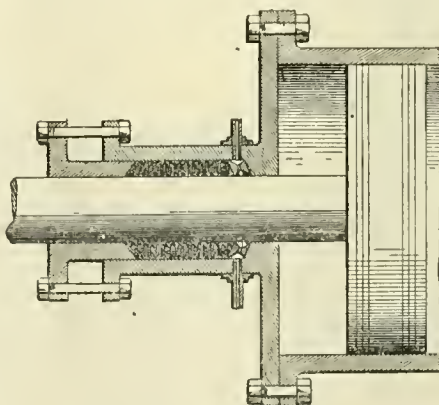

STUFFING BOX.

cylindrical casing with an open end, with packing rings formed with concave surfaces and a gland adjustably secured to the casing and formed with a concave inner surface. The gland and cylindrical casing are readily removable from the cylinder head.

#### STEAM BOILER.

Mr. C. E. Chapman, Fort Edward, N. Y., has patented a steam boiler. No. 835,400. The boiler consists of a shell containing a series of connected water tubes, including coils of arched fire box tubes, spiral tubes for the body, and a coil of crown header tubes. There are connections between the tubes whereby the water vapor or steam has first a movement in opposite directions to the direction of the products of combustion, and then a return movement. The coils comprise a forward series of three coils each, and intermediate series consisting of three groups of three coils each, and a rear series of four groups of three coils each, and a steam dome with a number of tubes having connection with a rear end header in the body.

#### JOURNAL BOX.

An improvement in journal boxes has

been patented by Mr. E. J. Trudeau, Sheridan, Mont. No. 834,340. The device consists of a journal box of the regulation form furnished with a plurality of intersecting diagonal bars or webs and sheets of reticulated metal integrally connected therewith. The bars or sheets extend from each side wall downwardly and inwardly to the bottom beneath the journal, the object being to re-

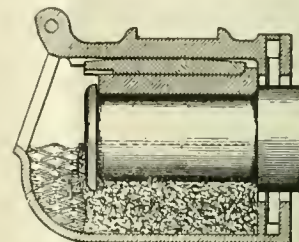

JOURNAL BOX.

tain the packing of cotton waste from slipping underneath or away from the journals.

#### CAR BOLSTER.

A very substantial car bolster has been patented by Messrs. Pflager, Westlake and Howard, St. Louis, Mo., and assigned to the Double Body Bolster Co., St. Louis. No. 835,552. The bolster comprises two opposite parallel end members spaced a suitable distance apart and connected together by two diagonally-arranged members to bear at the top against the car sills, the diagonal members intersecting each other at the pivotal central portion of the bolster and perforated thereat for the king-bolt.

#### LOCOMOTIVE PILOT.

Mr. F. W. Renner, Hites, Pa., has secured a patent for a pilot for locomotives. The device as illustrated consists of straps with arms hinged to the straps, a frame carried by the arms. Slots are arranged in the frame, and a resilient cover is carried by the forward rail. Coiled springs connect the frames, and chains form a connection between the arms and the

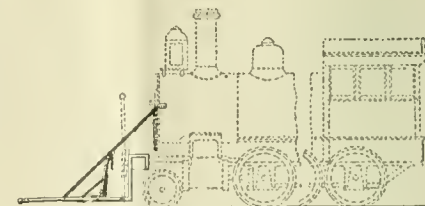

LOCOMOTIVE PILOT.

boiler of the locomotive for the purpose of supporting the pilot. The device possesses the elements of strength and flexibility.

#### LOCOMOTIVE LUBRICATOR.

A lubricator has been patented by Mr. J. F. McCanna, Chicago, Ill. No. 833,889. It combines a reservoir with a plurality of pumps supplied from the reservoir and

having connections leading to the parts to be lubricated, a cylinder and a reciprocating piston, a connection between the piston and the pump plungers, a source of fluid supply and a rotary valve for controlling the supply of fluid to and exhaust from the cylinder. There is also a pawl and ratchet mechanism for imparting intermittent rotary movement to the valve, and a connection with the mechanism to actuate the pawl and ratchet mechanism.

#### LOCOMOTIVE ASHPAN.

Mr. S. H. Lucas, New York, N. Y., has patented a locomotive ashpan. No. 833,965. The ashpan is of the usual rectangular form, with an open lower end and stop-shoulders on its front and rear walls, with bearing-plates secured upon the bottom edges of the side walls of the ashpan. There are transverse rocking-shafts journaled between the bearing-plates and the side walls of the ashpan, and shutter-plates fixed on the rocking-shafts arranged

#### Simple 4-6-2 for the Central of Georgia.

The Baldwin Locomotive Works have recently built ten Pacific and fifteen Consolidation type locomotives for the Central of Georgia Railway. The Pacific type, or 4-6-2 locomotives, one of which we illustrate, are designed for passenger service, and have a tractive power of 28,000 lbs. As the weight on the driving wheels is 113,660 lbs., the factor of adhesion is 4.06. These engines are well proportioned throughout, and have ample boiler power for the service required of them.

The cylinders, which are simple, are 20 x 28 ins., and are equipped with slide valves, actuated by the Stephenson link motion. The rocker shaft is placed immediately in front of the leading pair of driving-wheels, and is connected to the link block by a transmission bar, which spans the leading driving axle. The frames are of cast steel, with double front

of I-section steel and the crosshead is of the two-guide-bar type. The piston rod is secured in the crosshead by means of collar and nut.

The boiler is of the straight top type with sloping throat sheet and back head. It measures 66 ins. at the smoke box end and the barrel is supported by the guide bearer sheets and two intermediate waist sheets. The fire box is carried at each end on buckle plates bolted to cross ties. Both injectors are located on the right side, and feed through a double check valve placed on the top of the boiler at the front end. In the matter of heating surface the boiler is liberally supplied. The tubes give 3,188 sq. ft. themselves, as there are 280 of them each 19 ft. 5 ins. long. The fire box gives 169½ sq. ft., thus making a total of 3,357½ sq. ft. of heating surface in the boiler. This same area would about be enclosed in a circle 65 ft. 4 ins. in diameter. The grate area is 46.8 sq. ft., and this gives a ratio of

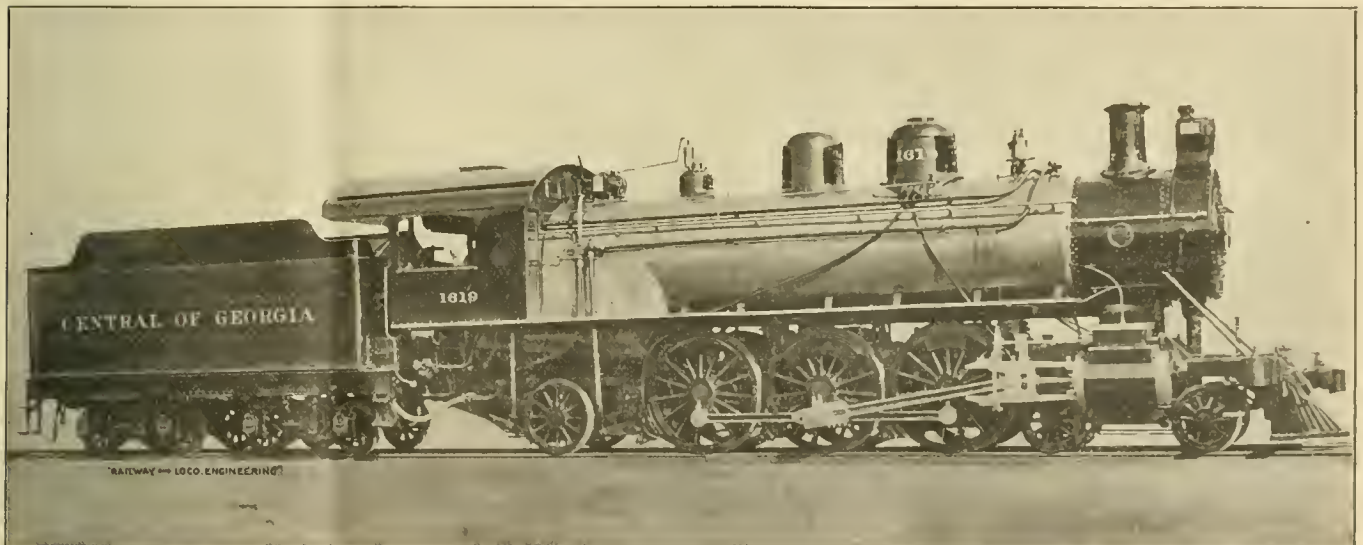

PASSENGER 4-6-2 FOR THE CENTRAL OF GEORGIA RAILWAY.

F. F. Gaines, Supt. of Motive Power.

Baldwin Locomotive Works, Builders.

to overlap each other in closed position to provide a floor or bottom for the ashpan, the endmost plates being adapted to engage the stop-shoulders on the front and rear walls of the ashbox. A crank-arm actuates the rockers and the bottom of the ashpan can be readily opened or closed.

#### BOILER TUBE CLEANER.

Mr. E. Mettler, Indianapolis, Ind., has invented a very ingenious boiler tube cleaner and secured a patent thereon. No. 836,267. The cleaner is furnished with a rotatable head having radial slots, each slot having opposed guiding surfaces, an arm arranged in each slot with trunnions bearing on the guiding surfaces. Cutters are carried by each arm, the head being divided into two separable parts in a plane transverse to its axis of rotation. The teeth of the cutters are staggered and are readily removable.

rails and separate rear sections. The rear truck is of the Rushton type, with inside journals.

The driving wheels, all of which are flanged, are 68 ins. in diameter, and are spaced 71 ins. apart. The driving springs are overhung and are equalized together and also with the trailing truck by means of a heavy equalizing bar with fulcrum which is capable of a certain amount of adjustment in the shop. The weight carried by the six driving wheels is 113,660 lbs., that on the front truck is 37,300 lbs. and that on the rear truck is 36,900 lbs., giving a total weight of engine of 187,860 lbs.; with the tender the grand total weight comes up to about 335,000 lbs. The rigid wheel base is 11 ft. 10 ins.; the whole engine wheel base is 30 ft. 4½ ins., and when the tender is taken into account the total wheel base of the whole machine becomes 58 ft. 5½ ins. All the rods are

grate area to heating surface as 1 is to 71.74.

The tender frame is built of 12 in. steel channels. The tank is U-shape, with a water bottom and a sloping floor in the fuel space. The water capacity of the tank is 7,500 U. S. gallons and 12 tons of coal is carried.

Some of the principal dimensions are as follows:

Boiler—Thickness of sheets, 11/16 in.; working pressure, 200 lbs.; fuel, soft coal; staying, radial.  
 Firebox—Material, steel; length, 108¼ ins.; width, 66 ins.; depth, front 68¼ ins., back 57¼ ins.; thickness of sheets, sides 5/16 in., back 9/16 in., crown ¼ in., tube ½ in.  
 Water Space—Front, 4 ins.; sides, 3½ ins.; back, 3½ ins.  
 Tubes—Material, steel; wire gauge, No. 11; diameter, 2¼ ins.  
 Driving Wheels—Journals, main, 9x12 ins., others, 8¼x12 ins.  
 Truck Wheels—Diameter, front, 33 ins.; journals, 5½x10 ins.; diameter, back, 42 ins.; journals, 7¾x12 ins.  
 Tender—Wheels, diameter, 33 ins.; journals, 5¼x10 ins.  
 Service—Passenger.

### The Object Lesson of the Chair.

BY A. O. BROOKSIDE.

The General Manager's office chair broke down the other day. That was on the G. G. & W. G. Railway, of which, you will remember, our old friend Eli Gilderfluke is general master mechanic. The G. M. was out when the catastrophe happened, but it occurred, took place and eventuated all the same. Billy, the office boy, broke it, and he came near unto the sacking point, but was rescued by Harding Steel, the general foreman, whom Eli did not like.

The G. M.'s office chair machinery was made as depicted. The rocking mechanism consisted of a casting with two lugs. One is marked *D*, and this casting is secured to an iron frame, which supports the seat of the chair. In the sketch, *F* is the fulcrum about which the whole thing rocks. *E* is the top of the screw by which the chair is adjusted to the required height. A spiral spring is in place between a seat on the casting *D* and a plate at *A*, and *A B* is a carriage bolt, with a nut *B*, like a valve handle, and by tightening up on *B* the spiral spring is compressed. The hollow cylinder or thimble *G* is a small but important casting and has a little rib across its face, which articulates; that is to say, rocks on the casting at the point *H*, leaving a space between, marked *C*.

When the G. M. tilts back his chair he rotates through a small angle about the point *F*, and the end of the carriage bolt *A* goes down, and bolt, spring, etc., rocks on the rib *H* of the small but important thimble *G*, while the nut *B* swings upward in the process of rocking. So far so good, and this is not an uncommon arrangement for an office chair, as you know, only the screw *E* ought to have been shown as fitting into a revolving nut, but that has really nothing to do with how Billy got into trouble.

The morning of the eventful day dawned bright and clear, and at 10.43 in the forenoon the G. M. laid down the record of death, disaster, foolishness and crime, commonly called the daily paper, and went out. Outside, Billy was lying in wait for the smooth visitor who knew the G. M. so well he didn't have to send in his name or state his business, was ready to hand such an one a lemon. Billy saw the G. M. go out of his private door. No one on the G. G. & W. G. road pretends to know what made Billy sneak past Joe Marks, the chief clerk, and go into the G. M.'s room, but in he went. After looking about for a minute, the devil got into Billy, and he sat down in the G. M.'s chair and began rocking to and fro (about the point *F*, of course) as the G. M. had done.

Billy had only rocked 247 times and was going back on the 248th stroke when bang went the chair, and Billy sat there motion-

less, tilted back for keeps, and the nut *B*, and the small but important thimble *G*, with a piece of the carriage bolt, shot off to the other end of the room, and almost fell at the feet of Joe Marks, who at that beastly moment swung open the door and walked in. Joe picked up the nut *B* and the small but important thimble *G*, and said, "Now, you've done it, you little brat." Of course the spring and the carriage bolt and everything loose had fallen to the floor, and the chair had a permanent set to the rear, and Billy said he "hadn't done nothink," etc., etc., and Joe Marks said he had etc., etc., etc., when in walked the G. M. and Eli, and there was a tableau.

When the G. M. heard all about it he said Billy must stay outside forever and ever or leave the road, and Eli looked at the fractured bolt and said it was due to unfair usage and the owner was not responsible because the weight of that very bad boy, tilted back so excessively—at that angle, you know, why, no chair in the world would stand it. Billy was distinctly told that he must forever keep outside or take the consequences. Billy volun-

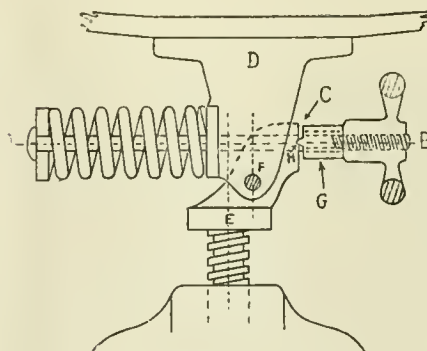

ROCKING MECHANISM OF THE G.M.'S OFFICE CHAIR, G. G. & W. G. RY.

teered to go away several miles, but that was disregarded. Just then Eli remembered that Harding Steel had come down from the shop that very morning to see him on most important business, and was even now in his, Eli's, office, at the end of the corridor. Billy was sent for Harding Steel to come and measure the carriage bolt, and to be prepared to soak the small but important thimble *G* in the lye vat, and take the nut *B* to the shop to have the imprisoned end of the bolt extracted, and general repairs made. Eli said it would not be necessary for the chair to go to the shop. The G. M. thus received consolation in the inverse ratio as 1 is to .0026.

When Harding Steel came he looked at things and said, "The chair might have required some oil." The G. M. and Eli looked displeased at the reference to something not used much on the G. G. & W. G., but the G. M. said the chair had worked all right for heaven knows how long with him, oil or no oil, and that Billy must be forcibly kept outside if necessary, and

forever. Eli said no bolt made by man's hands would stand a mischievous boy sitting upon the hack of the chair at that angle and violently rocking backward and forward at that rate, it was worse than a vibrating machine. "That's just what it is," said Harding Steel, "that is, without oil applied to the rib *H* of the small but important thimble *G*." Harding Steel did not mention these letters, but that is in substance what he said.

The G. M., who had pulled up the hard straight-backed, rush-bottomed visitor's chair and was sitting miserably on it, while his own swing-motion, swiveling, high-speed 4-4-2 chair was out of business, invited Harding Steel to speak further, and expound unto him the law and the prophets. Thus abjured, the general foreman said he only wanted to point out that on looking at the chair mechanism he saw that though the bolt, spring, nut, etc., had originally rocked about the rib on the small thimble, but never having been oiled and having become rusty through neglect (Eli thought the word "neglect" ill-timed and tactless), but Harding Steel went on, that the parts having become very rusty, the rib had fitted securely into the groove and the thimble and casting had practically become solid and that repeated movements of the bolt, free at one end and tight at the other, had acted like a vibrating machine and in time had broken the bolt, just like staybolts in a boiler, and that Billy had only by the merest accident happened to be on the chair when the inevitable breakdown had occurred. Somebody remarked that Billy's future would be one long unbroken stay outside. Harding Steele, however, advised that Billy be instructed after this to keep the chair in working order.

So it happened that Billy, who had been excluded from the room forever, was no most emphatically instructed, on pain of instant dismissal, to enter the room once a week, before the G. M. arrived, oil can in hand, and to proceed with due decorum and care, and with two steps forward and one step back, to approach the G. M.'s chair and oil and duly and reverently rock the chair on its sacred bearings, seeing, the while, that the rib *H*, on the small but important thimble *G*, was perfectly lubricated and worked freely. And it was done as ordered.

Moral: Do not double cross the office boy more than is necessary, nor banish him forever, for you may have to give him the royal entry and present him with the freedom of the room, in order that you may have comfort and that the rib *H* may rock freely, as designed, in the groove which has thereto been made and provided. It is also well to look carefully after staybolts, for they may break from much the same kind of vibration, and it is wise to inspect them constantly and repair them even as Harding Steel repaired the chair.

# General Correspondence.

## Smoke Box and Hot Box Troubles.

Editor:

There seems to be a great many puzzling questions these latter days confronting the newly promoted locomotive engineer, in fact, not only the newly promoted, but some of the engineers of the older school. The most annoying proposition they are called upon to surmount is getting an engine into terminal with her train with the petticoat, or diaphragm, down. In fact, if this kind of thing is properly handled, it is not really a serious drawback. For example, if the petticoat pipe falls down and fouls the exhaust tip, the smoke box door can be opened and the trap door of the netting removed and pipe taken out. This, in the opinion of many engineers, is considered a difficult thing to do, on account of the smoke and hot gases from the fire box. They imagine that it is necessary to have to get into the smoke box in order to remove the split keys from the netting trap door bolts. This, however, is not necessary with the average locomotive, as one can stand on the pilot sheet, and with cold chisel and a hammer can draw the keys from the bolts by inserting the chisel in the loop of the key and striking it gently it readily comes out. This, followed up until all keys are removed, the trap door of netting can be taken out and the rake can be used to haul the petticoat from over the exhaust, taken out entirely and placed on the rear of tank. This done, the netting trap can be replaced, the smoke box door closed, and you are ready to proceed. From practical experience I have noted that in nine cases out of ten, the engine will bring the train into terminal without much trouble for steam.

The all-round live engineer can overcome a trouble of this kind in about 25 or 30 minutes. This, of course, speaks exceedingly well of his ability as a locomotive engineer. It is quite the contrary when we find an engineer out on the road with the petticoat pipe down, and just because it is, and the engine has failed from this trouble, he also fails. This argues wonderfully against his qualifications. Every locomotive engineer should have a certain pride about him and should endeavor to be second to none.

To illustrate my point, I will direct your attention to a case of "dropped" petticoat pipe with an engineer the other day. The engine suddenly began to steam badly and the pressure fell back from 200 to 80 lbs., and when he shut off the smoke and blaze came out around the fire box door. In an instant he real-

ized what he was "up against" (using a common expression). The shut off happened to be for a water tank. He immediately opened the smoke box door and found one of the petticoat hangers broken, and the pipe leaning so that the exhaust was turned to one side of the stack base, thus the exhaust steam unable to get out of the stack destroyed the vacuum, putting the engine out of commission. He removed the keys above referred to, and netting, trap door, took

befell him. Some day this engineer will reap an ample reward, for he has done many excellent things to get his engine and train into a terminal even though adversity had overtaken him. He is a good man to pattern after; watch him closely, and "go thou and do likewise."

What can I say that could be done in case the diaphragm, or the diaphragm slide, or plate, falls down and "smothers" the engine? Well, this is not a very serious failure, from my viewpoint. Open

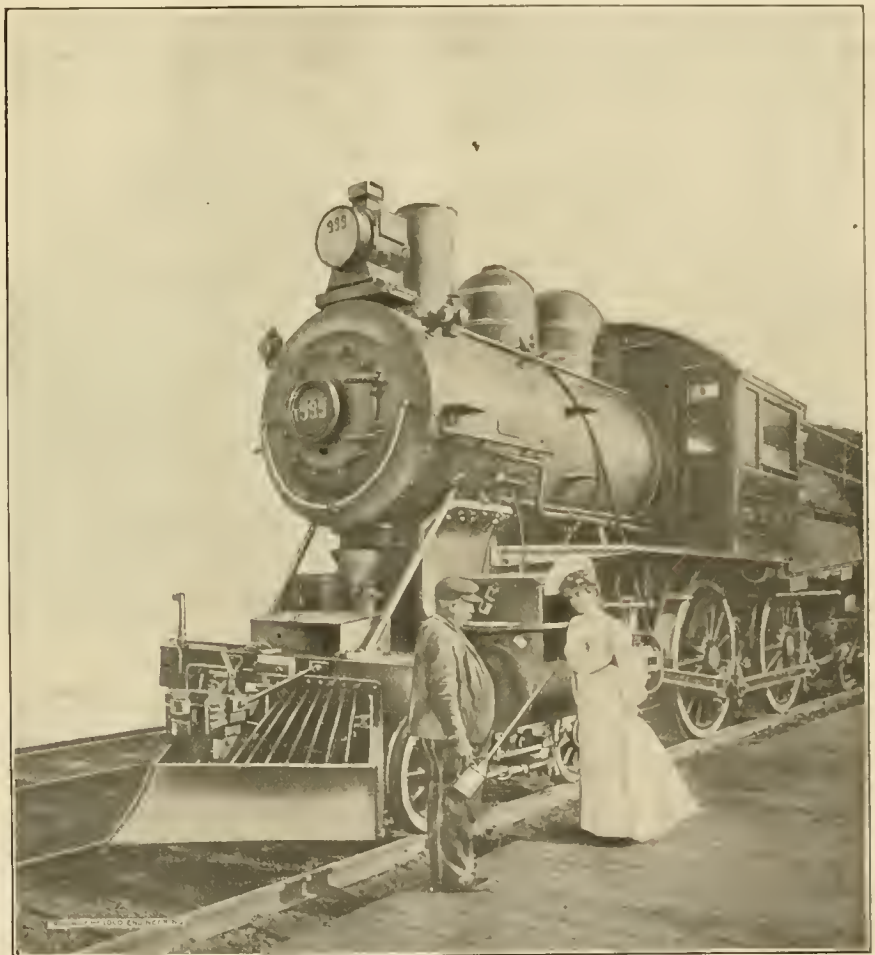

A FAULTLESS MEETING ON THE DUSTLESS ROAD.

the coal hammer and got up on the smoke box and broke off the other two hanger bolts and the pipe fell down, got the rake and pulled it out, placed it on the back of the tender, replacing the netting trap door, closed the smoke box tightly and was on his way (with the fast freight) in exactly 35 minutes.

I will add that this engine took her train into terminal, 100 miles, about on time, and experienced no trouble for steam. Of course, the engineer understood his business, and was perfectly willing to act promptly when the accident

the smoke box door, get the pinch bar, or anything that will answer the purpose of a pry, insert it under the diaphragm, or plate, pry it up and shove it into one of the flues. When you have the diaphragm as high as wanted, then allow the other end of the bar to rest on the flange of the smoke box door, or block it up on a steam pipe, close your smoke box and you are ready to proceed. I can advisedly assure you that you will not experience much trouble for steam, and you can take all of the train with the engine in this condition. If you are careful in

getting the bar properly inserted and blocked to hold the plate in its place, as near as you can judge it, you may rest satisfied that you will get to destination without further annoyance.

I will now say a word about what contributes largely to hot driver journals, crank pins, and broken rod brasses. I have found that many of these items have been developed from improperly setting driver box wedges and keying both side rod and butt-end main rod brasses. There is an educational institution that I have in mind that teach its pupils to set driver box wedges while the engine is standing on the "top" quarter, and in this position that rod brasses can be set to the best advantage is also taught. From practical experience, however, we have learned that setting wedges and keying brasses according to the teaching referred to is inimical to the best working condition of the locomotive. You shall have my views upon this subject, the result of experiment, and practically so.

Now, when a locomotive is working under, say, a full head of steam, about the time the crank pins come to about the eighth, after passing the back center, the steam port will begin to open and continue to do so until the full quarter is reached; the rod brasses are then exerting

driver journals, and in many cases hot or broken rod brasses. The reason for the pins and journals being larger at one point than another is due to the closing of steam ports while engine is passing center; then the push and pull on bearings are relieved, thereby permitting said

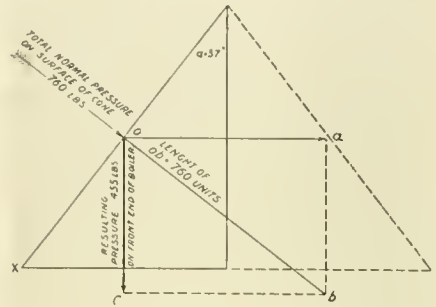

FIG. 1.—GRAPHIC PRESSURE DIAGRAM.

parts to become the larger. This much for the wrong way. My opinion of the right way:

The engine should be placed on the center, and if the driver brake is applied to wheel on the wedge side of the box, set the brake and allow it to remain so while the wedges are being adjusted; the brake will hold the box and journal against the shoe and in this way you will get all the slack, which will be in favor of the

care of by this treatment as that mentioned in the preceding paragraph. A 10-inch wrench is large enough to set up wedges with, and it is not so liable to stick the driver box as when a larger one is used.

JAS. SPELLEN,  
Road Foreman of Engines,  
B., R. & P. Ry.  
DuBois, Pa.

Shields on Locomotives.

Editor:

The subject of shielding locomotives in order to reduce atmospheric resistance, which is very considerable at high speeds, has been touched on briefly from time to time in the columns of railway engineering magazines and there have appeared a few illustrations of certain locomotives on European railways that have been partially equipped with these shields. The increased efficiency that such shields would give to our modern express locomotives can be ascertained correctly only by experiment, yet a fair approximation to correct results can be obtained theoretically by making use of a few well-known principles in mechanics.

In the treatment to follow it is assumed that the shielding is to be applied only to fast passenger locomotives run-

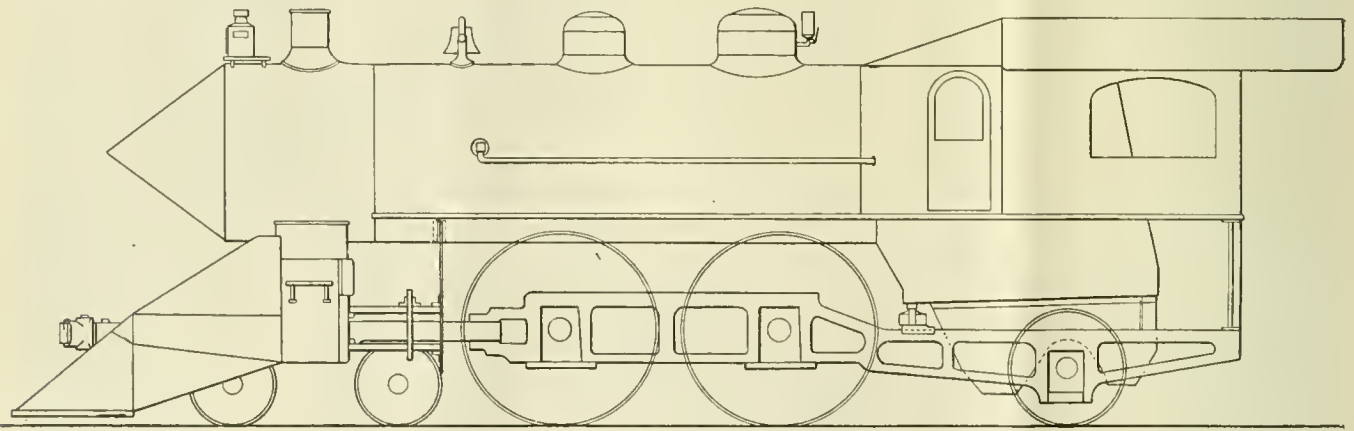

FIG. 2.—LOCOMOTIVE PROTECTED WITH WIND DEFLECTING SHIELDS.

their greatest pull on the crank pins and driver journals. This 'pull' has a tendency to wear the cranks and journals out of round, and if we calliper the cranks and journals of locomotives after they have been in service for any length of time, we shall find that the smaller part of them is about where the engine is passing the quarter, and the larger parts will be where the centers are passed. Then if we should place the engine on the "top" quarter and adjust the driver wedges and key the rod brasses, we are doing this setting and keying on the small part of the aforesaid bearings, and when the large part of bearings come round, the driver box brasses and the side and main rod brasses are going to grip the parts where they are the largest, and the result is hot

wedges. The adjustment can then be made to a nicety. Rod brasses should be keyed in this position of the engine also, as the keying is done on the large parts of bearings, and if the lubrication is ample the engine should give no trouble by heating. The binder braces should be first tightened, then the wedges, and lastly the rod brasses should be tightened. If this course is pursued, a locomotive can be kept in a pretty smooth condition.

If the driver brake is on opposite side from wedges, or if there is no driver brake, place the engine on the center, set up wedges as far as they can be set with 10-inch wrench, then pull them down until fairly loose, and finally set up to where in your judgment slack is sufficiently removed. Engine will be as easily taken

ning at an average speed of 60 miles per hour, and only the principal exposed parts of the locomotive will be taken into consideration. No attention is paid to eddy currents and it is furthermore assumed that the locomotive is running in a perfect calm in order that there will be no increase or decrease in pressure above or below that which is caused by the speed of the locomotive. The following dimensions are taken as a basis for the calculations:

Area of cab front, 30 square feet; area of boiler front, 28 square feet; area of saddle front, 5 square feet; area of valve front ends, 5 square feet; area of cylinder front ends, 7 square feet; total, 75 square feet.

It has been found experimentally that

a wind blowing at the rate of 60 miles per hour exerts a pressure of 18 lbs. per square foot of a flat surface perpendicular to the direction of the wind. If this surface is turned so that the wind strikes it at an angle, there is a resulting normal pressure less than 18 lbs. to the square foot. This pressure varies according to the angle at which the surface is inclined. The same principle applies to a locomotive, except in this case, under the above assumptions, the plane of the exposed parts is moving against atmospheric resistance. Thus, if a locomotive is running at the rate of 60 miles an hour, and the aggregate amount of exposed surface is 75 square feet and the resistance is 18 lbs. to the square foot, the amount of work that must be done to overcome the resistance is  $75 \times 18 \times 5280 = 7,128,000$  foot-pounds. By dividing this number by 33,000 the result, 216 H. P., is obtained. In other words, the engines of the locomotive must develop 216 H. P. to overcome the atmospheric resistance when the locomotive is running at the rate of 60 miles per hour.

455 lbs. is obtained, which acts perpendicularly to the front of the boiler. The other component, *oa*, of the original force exerts no pressure on the boiler, hence the amount of resistance to the boiler

at an angle of  $20^\circ$ , in which case the normal pressure is 11 lbs. to the square foot. Taking the area of this shield as 120 square feet and proceeding in the same way as in the case of the cone on the



CALEDONIAN 4-6-0, ONE OF THE 903 CLASS.

front is 455 lbs. The total pressure on the boiler front without the shield is equal to the product of its total area in square feet and the pressure in pounds per square foot, or, 504 lbs. Since the total pressure is only 455 lbs. when the shield

boiler front, the reduction of pressure on the cab front is found to be 90 lbs. This is equivalent to a saving of 144 h. p.

If the valve ends, cylinder ends, saddle front and pilot are shielded by inclined surfaces sloping at an average angle of  $30^\circ$ , the saving would be between 6 and 8 h. p. Thus, a total theoretical saving of between 28 and 30 h. p. is effected by shielding the principal exposed parts of an express locomotive when it is running at the rate of 60 miles an hour. The actual pressures on the cab shield and boiler shield are less than 11 lbs. and 16 lbs., respectively, but these figures were used in the calculations in order to give an allowance for error due to theory and that the results might not be exaggerated.

Nashville, Tenn. E. C. LANDIS.



CALEDONIA 4-6-0, ONE OF THE 918 CLASS.

If the exposed parts, above mentioned, are protected by suitable shielding, a general idea of which is given in the illustration, Fig. 1, the resistance will be reduced. A cone is placed in front of the boiler which slopes at an angle of  $37^\circ$ . Taking the diameter of the boiler to be 6 ft., the exposed area of the cone will be 47.5 square feet, but since this surface makes an angle of  $37^\circ$  with the direction of the resistance, the normal pressure will be reduced. This pressure is found, by formula, to be 16 lbs. to the square foot, which gives a total normal pressure of 760 lbs. for the entire surface. The resulting normal pressure of 455 lbs. on the front end of the boiler is obtained graphically as follows, and is shown on the diagram, Fig. 2.

Let the angle *a* be  $37^\circ$  and the arrow line represent the total normal pressure of 760 lbs. Produce this line to *b*, making *ob*, 760 units in length. From *b*, draw *bc*, parallel to *xx*<sup>1</sup>, and by measuring *oc* with the same unit of length used in laying off *ob*, a total effective pressure of

ic used, there is a reduction of 50 lbs., taking it in round numbers. Hence the saving in horse power by shielding the front end of the boiler is

$$\frac{50 \times 5280}{33000} = 8.$$

The shield for the cab front slopes at

### Caledonians.

Editor:

I have pleasure in sending you photographs and memo of dimensions of the three different classes of engines we have turned out from our St. Rollox shops in

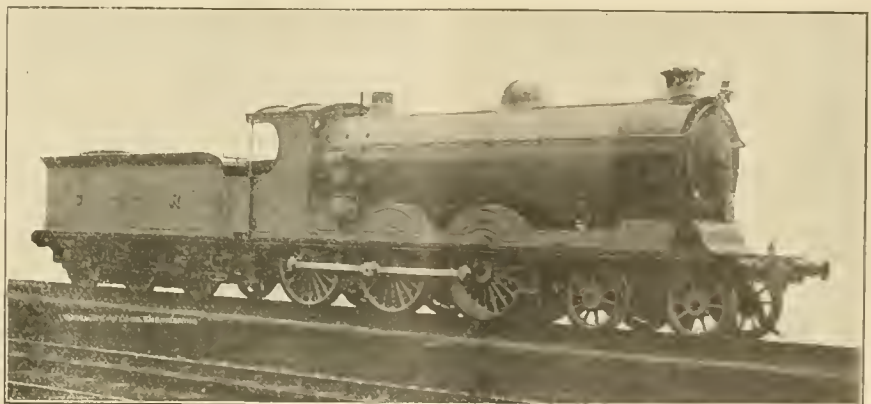

CALEDONIAN 4-6-0, ONE OF THE 908 CLASS.

1906. One of the "903" class has been named "Cardean" after the estate of one of our directors, and one of the "908" class the "Sir James King," out of compli-

	"903"	"918"	"908"
Cylinders .....	20 x 26 ins.	19 x 26 ins.	19 x 26 ins.
Coupled wheels.....	6 ft. 6 ins.	5 ft.	5 ft. 9 ins.
Grate area.....	26 sq. ft.	26 sq. ft.	21 sq. ft.
Boiler pressure.....	200 lbs.	175 lbs.	180 lbs.
Weight of engine.....	73 tons	60 tons 8 cwt.	64 tons
Weight of tender.....	57 tons	38 tons	38 tons
Tender, fuel capacity.....	6 tons	4½ tons	4½ tons
Tender, water capacity.....	5,000 gals.	3,570 gals.	3,570 gals.
ENGINE AND TENDER.			
Length over buffers.....	65 ft. 6 ins.	57 ft. 6 ins.	58 ft. 11 ins.
Total weight.....	130 tons	98 tons 8 cwt.	102 tons

Joy and Walschaerts' Gears.

Editor:

Though recognizing the necessity of a radical change in the valve gear of a modern locomotive, I cannot but regret the general adoption of the invention of Walschaerts.

It is undoubtedly a fine motion as far as it goes, but if adopted at all generally I think American practice will have lost one of its strongest points—"simplicity."

There are other outside gearings that have given splendid results and the one that I wish especially to mention, the Joy valve gear, would, I think, be admirably fitted for American practice.

It is the invention of the late David Joy, and to quote from a well-known locomotive treatise, "of all radial gears this has been most extensively applied to locomotives, and is probably the best radial gear known so far. It comprises few parts and gives, theoretically at least, a faultless distribution," though, "the rise and fall of the axle . . . affects the distribution to some extent.

"It is simple in construction and maintenance, the dead weight of the whole is less, and it is generally more correct in working, as, if the centre lines of the various levers, etc., are properly set out a valve part diagram is given in which the lead and cut-off are exactly equal for both ends of the cylinders, and they remain so for all grades of expansion to mid-gear.

"The valve opens more rapidly than when actuated by link motions, the cut-off being prompt and the release of the exhaust quick, while it moves slowly during the expanding and exhausting periods. These qualities are very desirable for a locomotive slide-valve, when obtained without any undue lead, compression or too early exhaust.

"The cut-off is not limited by the throw of the eccentrics, etc., but the reversing depends upon the angle to which the quadrant block guides are inclined, so that it would be only necessary to allow these to be carried over past the point usual for a full gear cut-off of, say, 75 per cent, to obtain a cut-off of 80 or 90 per cent; thus, the starting power of the engine can be greatly increased, and the trouble sometimes necessary of reversing to get it into a more favorable position dispensed with."

When all these points are taken into consideration this gear would seem to have been especially invented for the heavy modern locomotive, and should a trial be made of it, this gear would surely meet with success.

RICHARD E. PENNOYER.

Berkeley, Cal.

The first really practical sewing machine was invented by Elias Howe, of Cambridge, Mass., in 1841.—Journal of Education.

ment to our chairman. The last of the latter class has just been completed now. Below is a list of dimensions.

JOHN F. MCINTOSH,  
Glasgow. Locomotive Supt.

thing to the proposed railroad museum, that is all it is fit for. It certainly is not fit to move the traffic of an up-to-date railway.

Cape Breton.

D. W. McDONALD,  
S. & L. Railway.

Air Sanders All Right.

Editor:

In your November issue of RAILWAY AND LOCOMOTIVE ENGINEERING, a fellow tells all he don't know about "Air Sanders." He satisfies himself and tries to convince others that they are only a fad, and gives some of his reasons for condemning them. He can't keep moisture from working in through unions. Think of an engineer who can't make a union keep out rain water. He claims that nozzles wear out in a very short while. If he would cool down and consider that only air passes through the nozzles, and that it takes an awful lot of air to wear out nozzles or anything else, he certainly would not use such silly arguments to decry one of the best and most useful locomotive appliances.

His arguments about adjusting flow of sand are just about as good as the first, and only show that he should use a great deal more common sense and judgment. To my way of thinking, the air sander is indispensable on our heavy engines, and any practical engineer would just as soon part with a wheel as he would with his sander. We use them on our road and except in case of accident, never have to renew any part from the time engine leaves shop till she goes back. They do occasionally collect a little wet sand at the end of the pipe, but an engineer can knock this out without loosening all the joints and start them leaking.

After our engines were equipped with air sanders, one of our old men, who had used hand sanders for twenty years, was asked how he liked the new sander. His answer was, "If any railroad man will get to heaven that Leach feller will," and I guess his invention helps engineers to live happier and do better work. The man who wants an Armstrong sander should have an Armstrong brake, for there are joints on the others and they might start to leak on him. Perhaps you might throw in an old boiler pump, too; then take him and his whole outfit and send the whole

Old "L" Puffer in China.

Editor:

Your magazine RAILWAY AND LOCOMOTIVE ENGINEERING is very welcome every month, and keeps me in touch with modern locomotive practice and design.



FORMER "L" PUFFER, IN CHINA.

Enclosed find a photograph of one of the old "L," New York elevated locomotives, which is one of eight used on this railroad out here, on the Canton-Fat Shan Branch.

Although the photograph is not very plain, perhaps you can make use of it in your valuable magazine, and I am sure it would be very interesting to the old "L" engineers.

The camera was "snapped" by the Chinese fireman, the Chinese engineer is seen in the cab window, the Chinese No. 1 man, or shop foreman, in front of air pump.

The man with hands on hips is the master carpenter, one of the two white men employed on the road. The one in front of the pilot is myself in uniform.

If the photo is too dim for use, or should you want another, I shall be pleased to get another one for you, but it will take some time, as Canton is a long way from New York.

R. E. OLMSTEAD,  
Chief Machinists' Mate,  
U. S. S. "Callao."

Canton, China.



**Bad Steamer With Good Front End.**  
Editor:

In the November issue of your valuable paper, under the heading "Traveling Engineers and Front Ends," I read in that same article some of the causes for engines not steaming, and the trouble not found to be in the front. I was some time ago assigned to a 4-6-0 20 x 26 in. engine, 200 lbs. pressure and having to furnish 80 lbs. pressure to run the dynamo on the train and expected to do a "rag-time" when late.

On first taking this engine, I found that she steamed very poorly. I found that the engine would fill up in the front end of the fire box and clinker her fire badly. They were not using any arches at the time and she would pull all of her fire up against the flue sheet, cutting off nearly all of her draft. The supposition was that the draft sheet, or diaphragm, was too low, and I supposed that she had too much draft through her bottom flues. The draft sheet was raised, but this seemed to only make the case worse. Everything else was examined in her front end and found all right. The trouble was this: after the fire was knocked out of this engine, I went down under her while over the pit to examine the grates. While there I found that the right hand over-flow pipe went down just underneath the frame and was bent up close to the grates and about on a line to make it level with the slope of the fire box, and it kept a spray of steam all over the front section of the grate, and especially when the injector was primed,

against her grates, practically killing her fire in the front section. I had this pipe moved and put down in the bottom of the pan, and the engine never gave any more trouble for the want of steam, and burning a rather poor class of coal. I

**Hospital Car on the Erie.**

Part of the rolling equipment of the Erie Railroad is an hospital car. It is 60 ft. long over end sills and is 8 ft. 11¼ ins. wide. The car has platforms at both ends, similar to those used on the observation



HOSPITAL CAR ON THE ERIE RAILROAD.

have noticed on a great many engines on some lines that there seems to be very little attention paid to where they put these over-flow pipes, but they should be placed in the pan, but as low down as they can get them so there would not be any trouble with them affecting the fire because they are needed in the ash pan for the benefit of the fire cleaners and

ends of ordinary passenger cars. The step covers can be put down and gates closed when it is desired to prevent curious and not helpful individuals from gaining access to the interior.

The car is mounted on two six-wheel trucks, which make it ride as smoothly as a Pullman. Underneath the car equipment boxes have been placed, with doors opening outward, for the storage of apparatus which it is not necessary to carry in the interior compartments. The inside finish is of a composite board made for the purpose, without beading, molding, carving or other projections which might serve as places for the collection of dust or dirt, or where infectious matter might lodge. White enamel paint is used as a finish, and the floor is covered with white rubber tiling.

The car is divided into two compartments. One of them, 43 ft. 3 ins. in length, is known as the ward. It contains eleven brass beds, or what may more properly be described as hospital cots. The other compartment is 15 ft. 9 ins. long and is the operating room. This contains the surgeon's lockers, operating table and accessories, such as would be found in any good emergency hospital. The compartments are separated from one another by a partition in which there are two sliding doors with ground glass windows. These doors are designed so as to give maximum opening when it is necessary to bring a patient from the ward to the operating table. This compartment is provided with two sliding doors, 48 ins. wide, through which patients can be car-

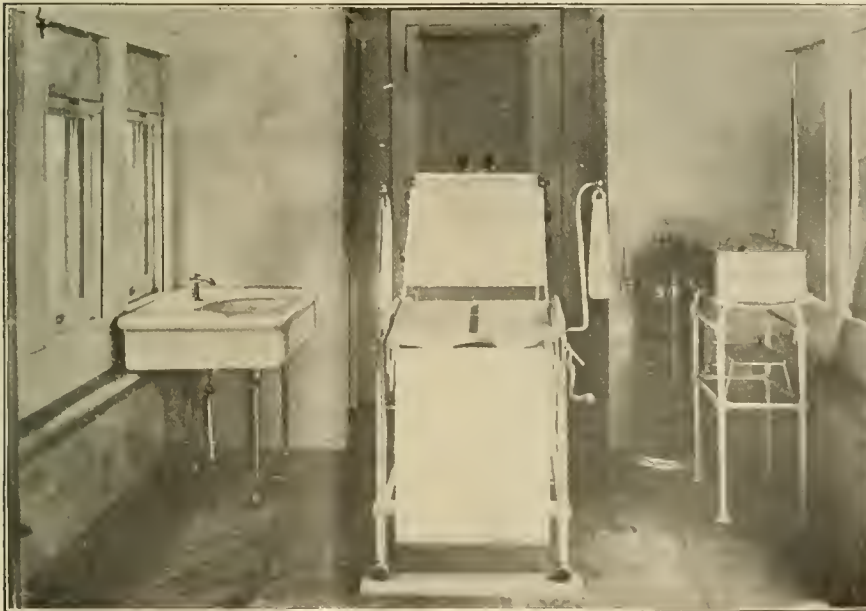

OPERATING ROOM, ERIE HOSPITAL CAR.

and there seemed to be a considerable amount of leakage from the checks and valves, and when the engine was working she would suck this drainage right up

keeping the pan from being burned up and warped when the grates are shaken along the line of road.

Savannah, Ga.

M. H. GRAY.

ried. Suitable steps, usually carried under the car, can be placed in front of the sliding doors when it is necessary to use them.

Ample light is provided in the ward by twenty-eight windows, of which there are fourteen on each side. All of these are provided with ground glass. There are also six side windows opening into the operating room and two large windows in each of the side doors. In addition to these windows there is a large ground glass window over the operating table in the roof of the car. All these windows are provided with roller curtains made of white rubber. This material is also used for the curtains enclosing the cots. The rubber curtaining is easily cleaned and insures freedom from infection.

The car is also well equipped with acetylene lamps, of which there are four 4-flame lamps in the ward; two 4-flame lamps in the operating room; one 1-flame

which is in general use on the Erie passenger equipment, and ample provision has been made for keeping the car warm in the severest winter weather. The beds in the ward are furnished complete with springs, hair mattresses, rubber sheets, linen and blankets and are very similar to the regular hospital bed, the dimensions being such as will best suit the length and width of the car. The operating room has two lockers in which are stored the supplies required by the surgeons in such work as they may be called upon to do, and the entire equipment is modern in every way. Medical supplies of the latest make are used, and should it be necessary to call the car into sudden requisition, there is nothing lacking to insure the highest efficiency in the work of saving human life or relieving suffering.

Mr. Edward B. Leigh, president of the Chicago Railway Equipment Company,



HOSPITAL WARD ON ERIE CAR.

lamp in the operating room, over the wash basin, and one 1-flame lamp in the toilet room. There is also a portable lamp which can be used by the surgeons if it becomes necessary to perform any operation requiring the use of artificial light.

The car is equipped with a gravity water system, supplying the wash stand in the operating room, the sterilizer, the wash stand in the ward and also the lavatory. The system is arranged to furnish either hot or cold water, as may be required, and provision has been made in the operating room so that the flow of water can be regulated from a valve operated by treadle, thereby avoiding the necessity for handling any of the water equipment. This is the method employed in all modern hospital arrangements.

Both the operating room and the ward have the Gold direct system of steam heat,

has published an essay on the control of railway trains in emergency as well as in ordinary service. Mr. Leigh has had an extensive experience with braking appliances, and the work before us shows how he has mastered the subject. The history of the improvements in the control of trains from the time when an engine brake, supplemented by two brakemen stationed on the train ready to set up brakes on receiving a signal, is traced, and the law requiring the equipment of freight cars with acceptable air brakes is pointed out. The difference between passenger and freight service is lucidly treated, especially the conditions that cause more slack in the brake rigging of freight equipment, some of which are not apparent to the ordinary observer, notably the deflection of the brake beam. The Report of the Committee on Brake Beams at the Master Car Builders' Association is embodied in

the work and is accompanied with illustrations that enhance the value of the book.

#### Wrong Statements vs. Accuracy.

About thirty years ago Angus Sinclair read a statement in a popular magazine to the effect that the first railroad in America to have cars pulled by a locomotive was part of the New York Central Railroad, that the name of the locomotive was the "John Bull," an engine with an upright boiler later known as the Grasshopper class. Mr. Sinclair had seldom seen so many mistakes made in such a short article, and having been a student of railroad history, he determined to write a History of the Development of the Locomotive Engine. He has been working on the history ever since, and it is now on the press and will be out in a month or two. The mistakes in the article referred to were that the Mohawk & Hudson Railroad, which was the road referred to, was opened by the "De Witt Clinton" and not the "John Bull," which latter was the first engine that belonged to the Pennsylvania Railroad, and which ran on the Camden & Amboy portion of that road. Neither the "De Witt Clinton" nor the "John Bull" had upright boilers. The engine that was later known as one of the "Grasshopper class" was the first kind of engine used on the Baltimore & Ohio Railroad. Thus it appears that the article written long ago was wrong in nearly every particular, and the writer of that day was closer to the facts in point of time than we are at the present time. This shows the importance of verifying statements. Accuracy will be one of the characteristics of the book on the "Development of the Locomotive."

The book treats of the locomotive as it has gradually grown from Hedley's "Puffing Billy" and Cooper's "Tom Thumb" to the magnificent engines that are pulling our passenger and freight trains to-day. The process of evolution is carefully described with many personal sketches of the men whose inventions and work have contributed to the perfecting of the locomotive.

When Andrew Carnegie was engaged writing the life of James Watt he read parts of Mr. Sinclair's book and made a note to his book which said, "The 'Development of the Locomotive' promises to become the standard." It has the same size and type of page as the Master Mechanics' Association reports, contains about 700 pages and 300 excellent engravings that graphically tell the history of the locomotive from the time of Stephenson and Cooper and Winans, Baldwin and Norris up to the work of Vaclain and Pitkin. This book is well under way at the present time and the author expects to have it out some time in February. Orders will now be received. The price is \$5.00.

### Steel Rails.

"Steel Rails" was the subject under discussion at the meeting of the New York Railroad Club last month, and Mr. Robert Job presented a lengthy paper illustrated with stereopticon views showing sections of the heads of rails magnified fifty diameters. Mr. Job claimed that the composition of the rails is better to-day than formerly, yet it is a well-known fact that the old rails gave generally excellent service, this being due largely to the thorough working of the steel down to a low finishing temperature. The increased weight also, from 60 or 65 lbs. to the present day standard of 90 or 100 lbs. per yard, has upset the ratio between the various components of the area of the rail; that is, head, web and flange. The head is far thicker and of much greater mass than formerly, while the other parts have increased but little in thickness, or even have, in some cases, decreased. As a result the flange gets to the lowest temperature at which it can be rolled long before the head reaches the same temperature, so that if the flange be fine grained and tough, the crystals of steel in the head may be very rough, since they grow in size from the time that the pressure upon them in the rolls cease until the steel at that point has fallen below a dull red heat. This condition adds to the brittleness of the rail and accelerates its rapid wear. Mr. Job recommended the rearrangement of the proportions of the rail or a change in the treatment of the steel, either during the rolling or subsequently.

Mr. T. H. Johnson, consulting engineer, presented an interesting report of the experiments that had been carried on for a number of years on the Pennsylvania Railroad, and agreed with Mr. Job in the essential feature that the only way to secure a uniformity of fine-grained texture throughout the section of the rails was by a proper regulation of the heat treatment during the rolling. It may be noted that there are two critical temperatures in the rolling, the higher temperature 1830° F., above which the shape may be transformed without affecting the texture, and the lower, a little over 900° F. The nearer the finishing temperature approaches the lower limit, the finer will be the grain of the metal.

Mr. C. H. Ewing, of the Philadelphia & Reading, also spoke and apologized for the manufacturers as having exceptional demands made upon them in keeping pace with the orders.

Mr. L. R. Pomeroy, of the General Electric Company, described an annealing method whereby rails were reheated to a light cherry red and cooled as quickly as possible by means of submerged jets playing in the rail, thereby producing a combination which increased the elastic limit about 25 per cent.

Prof. P. H. Dudley contributed to the

debate, as also did Mr. W. L. Derr, both submitting the account of very interesting experiments.

Fourteen new applications for membership in the New York Club were made. The annual report showed a membership of 1,364, with a cash balance of \$15,880.44. The election of officers was declared as follows: President, H. H. Vreeland; first vice-president, John F. Deems; second vice-president, W. G. Besler; third vice-president, H. S. Hayward; treasurer, R. M. Dixon; executive member (for three years), Frank Hedley; member finance committee (for three years), Otis H. Cutler.

Cassier's Magazine has been sold by the estate of the late Louis Cassier to Mr. Henry Harrison Suplee, for many years the technical editor of the Engineering Magazine, and Mr. James Van Vorst Colwell, recently works manager for the C. W. Hunt Company, and the publication will be continued as hereto-

some time ago that he had been bothered that way once or twice when it made things downright awkward. The table at his station was a long one with a good deal of spring to it, and so it had to be kept high in the centre, and the result was that when an engine started to come off it, the table came down hard on the race track at the end toward which the engine was moving and when the locking mechanism became loose, as it is likely to in time, the track on the table and on the ground did not coincide at the critical moment and the result was that the leading engine truck wheel sought the ties.

When this happened the wheel invariably settled down in the space between the ties and just took that much longer to get it on again. As this was liable to happen any time with the kind of table he had, even after everybody had been warned, the foreman put in three extra ties between the regular ones, where they carried the track to the turntable. The

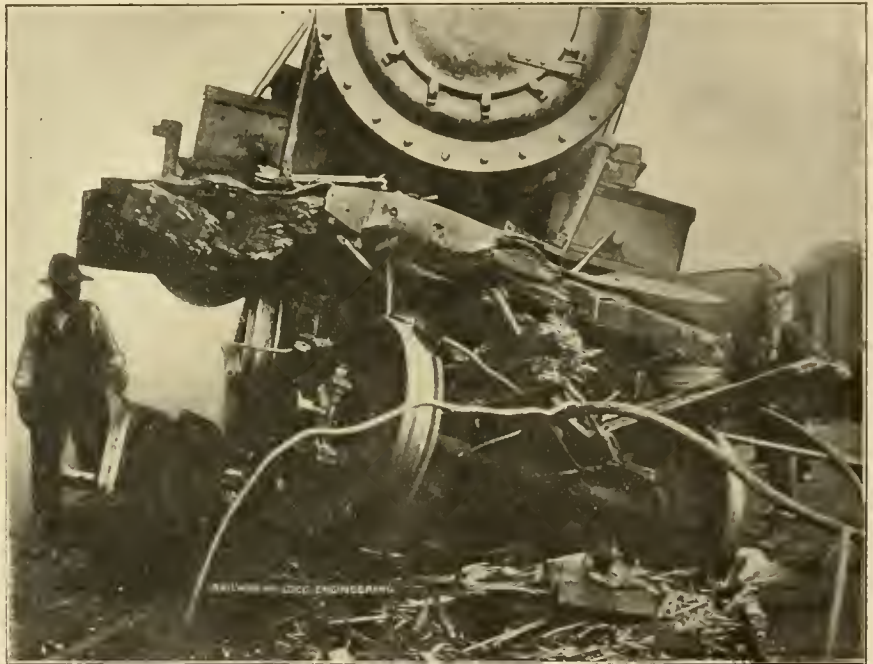

RESULT OF A MISPLACED SWITCH.

fore by the Cassier Magazine Company at No. 3 West Twenty-ninth street, New York. The editorial conduct of the magazine will be in the hands of Mr. Suplee, who brings to this work a wide experience both in the practice of mechanical engineering and of technical journalism, while the business department will be directed by Mr. Colwell. The first issue of the magazine under the new management is the January, 1907, number.

### Extra Ties Helped.

It is against rules and good practice and common sense to get an engine off the track at the turn table, but it some times happens even on the best regulated railways. A locomotive foreman told us

rails close to the turntable therefore rested on a solid floor made of about four or five ties, with no spaces between them. When next an engine truck wheel got off, it got on again without much trouble as it had no soft earth or sand to sink into, there being no space between the ties. Of course the real way to avoid trouble at a turntable is to keep on the track, but that is not always done, though theoretically it should be, and when it did happen at this station the foreman said he found the extra ties came in handy. The strange part of it was that as soon as means had been provided for making the re-railing process easy, not even a hand car got off the track. That is pretty much like the way carrying an umbrella keeps off the rain.

# Railway and Locomotive Engineering

A Practical Journal of Railway Motive Power and Rolling Stock.

Published Monthly by

**ANGUS SINCLAIR CO.**

136 Liberty Street, New York.

Telephone, 984 Cortlandt.

Cable Address, "Loceng," N. Y.  
Glasgow, "Locauto."

## Business Department:

**ANGUS SINCLAIR, President.**  
**FRED M. NELLIS, Vice-President.**  
**JAMES R. PATERSON, Sec y and Treas.**

## Editorial Department:

**ANGUS SINCLAIR, Editor.**  
**GEO. S. HODGINS,**  
**JAMES KENNEDY,** } Associate Editors.  
**J. P. KELLY,**

## Advertising Department:

**Eastern Representative, S. I. CARPENTER,**  
170 Summer St., Boston, Mass.

## British Representative:

**THE LOCOMOTIVE PUBLISHING CO., Ltd.,** Amen Corner, Paternoster Row, London, E. C.

## Glasgow Representative:

**A. F. SINCLAIR, 15 Manor Road, Bellahouston, Glasgow.**

## SUBSCRIPTION PRICE.

\$2.00 per year, \$1.00 for six months, postage paid in the United States, Canada and Mexico. For other parts of the world, \$2.50, or ten shillings. Single copies, 20 cents. Remit by Express Money Order, Draft, Post Office Order or Registered Letter.

Mailing address can be changed as often as necessary—always give old and new address, and if you subscribe in a club, state who got it up. Please give prompt notice when your paper fails to reach you properly.

Entered at the Post Office, New York, as Second-class mail matter.

Copyright by Angus Sinclair Co., 1906.

For Sale by Newsdealers Everywhere.

## Our European Edition.

Entering the year 1907, RAILWAY AND LOCOMOTIVE ENGINEERING greets its old friends with best wishes for the future. At this time it is especially pleasing to announce that in response to a steadily increasing demand for our paper in Great Britain and on the Continent we have been compelled to prepare a special edition which is shipped to the other side at the earliest moment after our paper comes off the press and before the last of our large American edition can be fully distributed. The field of engineering is world wide, and if we are able to carry some useful information or help to bring to the knowledge of those in distant lands, some of the good things our own manufacturers give us in this country we will consider that our European Edition has effectively served its purpose.

## The Risk of the Trade.

If the suggestion outlined in President Roosevelt's message to Congress, which was promulgated in the early part of December, should be followed by legislation embodying his views, it would constitute a step of probably more far reaching importance to railway men in this country than any which has hitherto been even

seriously considered. Last year a law dealing with the "fellow servant rule" was passed. As far as railway corporations were concerned this took from them the right to use as a defence the fact that an injured employee, claiming damages, had not previously and formally protested against the employment of the man who was responsible for the accident—a thing which under modern conditions it was practically impossible to do.

Speaking of what he considers rightfully to be the employers' liability, the President says: "Among the excellent laws which the Congress passed at the last session was an employers' liability law. It was a marked step in advance to get the recognition of employers' liability on the statute books, but the law did not go far enough. In spite of all precautions exercised by employers, there are unavoidable accidents, and even deaths, involved in nearly every line of business connected with the mechanic arts. This inevitable sacrifice of life may be reduced to a minimum, but it cannot be completely eliminated. It is a great social injustice to compel the employee, or rather the family of the killed or disabled victim, to bear the entire burden of such an inevitable sacrifice. In other words, society shirks its duty by laying the whole cost on the victim, whereas the injury comes from what may be called the legitimate risks of the trade. Compensation for accidents or deaths due in any line of industry to the actual conditions under which that industry is carried on, should be paid by that portion of the community for the benefit of which the industry is carried on—that is, by those who profit by the industry. If the entire trade risk is placed upon the employer he will promptly and properly add it to the legitimate cost of production and assess it proportionately upon the consumers of his commodity. It is therefore clear to my mind that the law should place this entire 'risk of a trade' upon the employer. Neither the Federal law, nor, so far as I am informed, the State laws dealing with the question of employers' liability are sufficiently thorough-going. The Federal law should, of course, include employees in navy yards, arsenals, and the like."

The doctrine here set forth amounts to this: that a person employed on any railway engaged in interstate commerce, for that is what this kind of Federal legislation would apply to, would receive compensation for personal injuries, or his legal heirs would receive compensation for his death, from the railway, if the employee has been injured or killed while in the service of the company. This compensation would have to be given without the necessity of the injured party proving that the company had been negligent. The fact that he was injured or killed would practically constitute the necessary proof. In order to meet the inevitable increase in

the cost of operation which the payment of such claims would entail, the railways might be compelled to charge the traveling public or the shipper of goods, a higher rate than they now charge. This is contemplated in the President's message.

The state of affairs here outlined has been tried and is successfully working today in Great Britain. Under what is known over there as the Workmen's Compensation Act, passed in 1897, when a workman is killed, no matter in what way, his heirs-at-law are paid the equivalent of three years' earnings, reckoned at his rate of pay. When injured, he receive half pay during the period of disability. The only restriction to this is in case of his serious and wilful misconduct. This is construed so as to practically make the suicide of an employee the only bar to a claim for compensation.

In this way the general result is that the amount paid on accident claims to employees becomes part of the cost of operation, and the community at large bears the burden, which in this country is now carried by the victim or his family alone. This produces a powerful incentive safeguarding operation, by the employer, and he also looks well to it that those whom he employs are very careful also, in the way they work.

When speaking in the House of Commons on the workmen's compensation bill, Mr. Herbert Asquith, then Home Secretary, put the whole case concisely, and stated the position of the government by saying, "the blood of the workmen should be part of the cost of production." President Roosevelt to-day uses language as easily understood as that of Mr. Asquith, when he says in effect that the "law should place the entire risk of the trade on the employer." Such a measure, if enacted into law, would practically cause the employer to become the insurer of the lives and limbs of his workmen and he would collect the premiums on this insurance from his customers.

It must be remembered that in passing such a law as the workman's compensation act, the British parliament has not to take into account the effect of a written constitution. There is only the remote chance of the King's veto, and this has not been applied to any measure for over a hundred years where the will of the people has been clearly manifest. In the United States the constitutionality of any similar act passed by Congress would probably be challenged, because the constitution provides that property, in this case money, may not be taken "without due process of law," and it is probable that the United States Supreme Court would hold that such an act did take away some part at least of the railway company's property, if it compelled the payment of death or injury claims to employees without their having to prove in

court the negligence or the failure in duty of the company.

The President has, however, set men thinking on the question as to who should bear the "risk of the trade," and it is possible that a way may be found which will lay the burden where he thinks it should be laid without doing violence to the constitution. In addition to abrogating the fellow servant rule, last year's legislation modified the contributory negligence rule, and the present suggested view of the employers' liability has in it a still further amplification of the same idea, and underlying it, or rather following it as a natural result, safe operation will become even more than it is now, economical operation, and this is a worthy object to be striven for. Employer, workman and the country at large would be benefited in proportion to the effort made to secure that method of operation, by which accidents of all kinds will be few and far between and injury and death will be reduced to the very lowest minimum.

#### So-Called Train Protection.

The Interstate Commerce Commission Bulletin No. 20, giving details of accidents for the months of April, May and June, 1906, is the latest one issued. In the second quarter of last year there were a total of 933 persons killed and 16,004 injured. These train accidents caused the death of 194 persons and the injury of 3,031. There were in the quarter ending June last as many as 1,588 collisions, all of which goes to show that the death roll of American railroads is still outrageously high. Of the collisions, 340 were rear, 170 butting, those caused by trains separating 168, and miscellaneous 90. The last item, the largest of the lot, is indefinite, but the figures show that there were just twice as many rear collisions as there were butting.

The fact that many roads have double tracks may account for the lesser number of butting collisions, but the danger from rear collisions is alarmingly great. It is, in fact, so serious that there is an urgent call for some adequate means of rear end protection. The flagman has long ago proved himself unworthy of being reckoned as a reliable form of train protection. The time interval between trains has been weighed in the balance and has been found wanting and the block system is on trial as used in America to-day, but just here arises the pertinent question what is meant by the "block system?"

A boy promenading the streets was shouting "Hot meat pies!" and delivering pies to everybody willing to put up 10 cents. One customer turned to the boy and accused him of misrepresentation. "These pies are not hot and there's no meat in them," protested the customer.

"You're a cheat and a liar!"

"Not so fast," answered the boy. "I do not say that the pies are hot or that they contain meat. 'Hot meat pies' is the name of this pastry and has nothing to do with its condition or contents. 'Hot meat pies.'"

This incident is directly applicable to a practice prevailing among railroad companies of denominating certain arrangements or rules for train operation as a "block system." Since the recent accident on the Southern Railway, which was made conspicuous by the death of President Spencer, the true meaning of the expression "block system" becomes apparent, and the misuse of the words stands out clearly enough. It is this loose way of talking which has a tendency to lead the public to believe that railroad collisions are inevitable, and that even the "block system" fails to keep trains from coming together with disastrous results. A little investigation of the so-called "block systems" will show that some of them have a close resemblance to the hot meat pies, but right here the humorous parallel stops abruptly, for misunderstandings on railroads generally means loss of life.

There are several kinds of legitimate block systems that aim to keep railway trains apart. When railroad operating was first begun the companies depended on the vigilance of the engineers and conductors to get their trains through safely, and these men performed the duty wonderfully well. But it came to pass that when trains became numerous and fast, mechanical aids were considered necessary to protect trains which were standing still, and fixed signals were established at stations for the protection of trains halting at these stopping points. The station protection signals were worked up to an elaborate extent and accidents at stations were very largely prevented, but it sometimes happened that trains stopped between stations, and other trains would run into them in spite of the protection supposed to be offered by a flagman sent out from the delayed train.

While the evolution of the system for protecting trains was going on, a very plausible but elusive plan was brought into operation, that of putting a time limit between trains, or prohibiting one train from passing a given point until the train which preceded it had been gone a specified time. It happened occasionally that the time margin for safety was ample, but if the preceding train had got stalled between stations a rear-end collision would occur.

That led to the introduction of the block system, by which a railroad was divided into blocks A, B, C, D, etc., and arrangements were made to prohibit two trains from being in the same block at the same time. There are several ways of regulating the operation of the block sys-

tem, the best known means being what is called manual controlled, the other the automatic electric control, and there is also the staff system. With the first named system, men are stationed at the towers separating the blocks. Their duty is to keep informed on the movements of trains and by an electrically operated system of interlocking, the towerman at B cannot let a train into block C until his signal levers are unlocked by the towerman at C, and this man cannot unlock B's levers until all trains are out of the block C, and the line perfectly clear. When properly worked out this is an absolute block system.

The automatic block system has an electric equipment and track circuit by which the signals are kept at danger behind a train when it is in the block. Under the train staff system the staff is really a key by which the signal lever locks can be turned and the possession of the staff gives the absolute right of way to the train having the staff.

The manual controlled block system is in operation on at least one American line and on the leading railways in Europe, and collisions between trains are almost unknown. The automatic electric system is used on many American railroads, and works well where the trainmen are properly instructed to obey the signals.

The system in use on the Southern Railway and on many other roads is known as the telegraph block system. Under it the telegraph operators at stations perform the duties something like those executed by the towermen of the manual controlled system, but they have many other duties to perform, besides watching trains, and it very often happens that failure to report trains in the block occurs. There is no system of locking signals or any mechanism requiring the joint action of two men before signals can be set at "all clear," and failures of memory sometimes lead to accidents. The system is used because it is cheap, it has no complete guarantee of safety, and is no block system at all.

Unless a block system is absolute it is worse than nothing, for it takes away the sense of responsibility from the engineer. The protection of stalled trains by flagmen is notorious for being neglected, as any one can testify who has been a passenger in a train stopped between stations.

American railroad trains could be operated as safely as those on European railways are if the same precautions were taken to prevent accidents. An absolute block system is essential, but the men operating the system must be trained to obey the rules absolutely. Most of our accidents are caused by those responsible for the movements of trains being permitted to habitually take dangerous chances. Day after day they run past signals to

save time and are often commended for getting their trains through on time, instead of being punished for violating important rules.

If railroad officials were sincerely anxious to absolutely do away with even the possibility of accidents, an automatic stop apparatus could be installed in connection with every danger signal, as they are on the express tracks of the New York subway, and no engineer would dare to or could run past such a danger signal. Introducing a system of that kind would cost a little money and at times it would cause a few minutes delay, but it would effectually prevent collisions, such as the one by which the death of the president of the Southern was caused. Every such accident hastens the day when the compulsory use of the most approved form of absolute block signalling will become the law of the land, and those roads which now have block systems worthy of the name should strenuously enforce the discipline necessary to make train protection in this country something more than a by-word and a lie.

#### Needs of the Patent Office.

American inventors are not only the most numerous of any nation in the world, but they are the most ingenious. In the atmosphere of American liberty there is encouragement for every honest effort in a laudable direction. Labor saving devices spring with mercurial swiftness into every channel of human endeavor. The rewards are very irregular and not in any sense in a ratio to the effort made by the inventor or the result accomplished. The invention may be of much real value to the community, but the crystallization of the appreciation of its use into concrete reward depends on other contingencies over which the inventor can have no control. The promoter must needs follow the inventor, just as the publisher follows the author, and the publisher is said by authors always to have the best of it.

Be this as it may, there is one real evil under which American inventors have long suffered and which time, that is said to have healing on its wings, only seems to aggravate. We refer to the delay which occurs in the United States Patent Office. At the present writing there are nearly twenty-five thousand applications awaiting action on the part of the office. There are an equal number of inventors all waiting, in many instances nearly a year, before an examination as to the patentability of their work can be begun. A report of the conditions of the Patent Office recently published establishes the fact that during the last seven years the applications for patents have increased seventy per cent, while the examining corps have increased only twelve per cent. There is a double vision in this report

showing the examiners must be working very hard now or they must have had a leisurely occupation prior to 1899. The latter is more likely the case, and we have no hesitation in stating that if the office were run on the same general principles as any well managed business establishment, much more work could be got out of the examiners. Work at the present time is said to amount to four examinations of claims a week. We are not alone in our opinion that this is not much for the money. In any event there is no good reason why the system of absurd and unreasonable delays should continue.

The inventors are not asking any favors. They pay well for the poor service they get. In the last seventy years the Patent Office has made a profit of over six millions of dollars. The present year will show a profit of over three hundred thousand dollars after paying all expenses. Why could not the force be increased? There is money enough to pay for one hundred and fifty more men to be added to the three hundred already employed. There is only one reasonable answer to this. It does not come within the scope or interest of any particular section of the country, and the inventors having no cohesion cannot maintain any "lobbyist" to promote their interests, and, as usual, what is everybody's business is nobody's business, and the matter drags on its weary way.

In our Patent Office Department in the pages of RAILWAY AND LOCOMOTIVE ENGINEERING we have complained again and again. We are pleased to give voice to the voiceless who are enduring real injuries. We know something of what American ingenuity has done in perfecting the mechanical appliances used on railways, and we are not without hope that our voice has not been altogether like a voice crying in the wilderness. Indeed we are much pleased to observe that a Patent Law Association, of which Mr. A. V. Cushman is secretary, has been established in Washington, having for its object the betterment of the Patent Office service. It becomes the inventors and manufacturers of America to sustain and uphold this association. In their interests it has been begun and in their interests we hope it will be carried on until Congress shall see fit to apply some of the funds which come from the hands of our inventors and not only reorganize the Patent Office system but erect a Patent Office building which shall be worthy of American Inventive Genius.

#### Leakage of Slide Valves.

Quite an interesting experiment was recently made on the direct leakage of steam through slide valves by Mr. J. V. Stanford, assistant professor in the mechanical engineering department of the university

of Pennsylvania. To understand the significance of the experiment it must be remembered that if the exhaust steam from an engine is condensed and the weight ascertained, there is usually a considerable difference between this weight and that got from an analysis of the indicator card. This difference which exists between the actual and the computed weights, is called the "missing quantity," and cylinder condensation is generally regarded as responsible for the whole amount. The result of Prof. Stanford's experiment goes to show that direct slide valve leakage should be charged up with part of the "missing quantity."

The engine experimented with was a 6x9-in. Sturvetant blower engine with D-slide valve 5 ins. wide, 4¾ ins. long, overlapping the ports ¼ in. on either side. The engine was run at about 3/5 cut-off. With the setting as given, the minimum width of bridge covered was 5/8 in. so that, as the experimenter tells us, the exhaust port was everywhere protected from direct leakage by contact between the valve and seat at least ¼ in. in width. The valve was of the balanced type. Any leakage past the packing rings to the exhaust cavity formed part of the missing quantity, as it passed out with the exhaust steam without showing on the indicator card.

In testing this engine two runs were made under normal load. The average results showed 5.13 h. p. and that the engine used about 91.2 lbs. of steam per indicated h. p. per hour. The next test was two runs with the balance plate removed and the 3/16 hole in the top of the valve plugged with wood. The runs with the valve unbalanced showed a steam consumption of 60.5 lbs. of steam per indicated h. p. per hour, or 30.7 lbs. less, due to the greater leakage with the valve balanced. In the first test steam leaked past the balance strips and under the valve into the exhaust cavity; in the second test the leakage was under the valve only.

The next test was made to determine the actual amount of this leakage under the valve, and to do this the steam ports in the cylinder were plugged with wood. One cylinder head was removed and the stuffing box opened so as to relieve any pressure in the cylinder due to steam getting past the wooden plugs. The eccentric was loosened on the shaft and bolted to a large wooden pulley placed beside it. This pulley was driven by a belt from a 1 h. p. electric motor and the eccentric was therefore turned at the same speed as in the previous tests. By this means the eccentric revolved while the shaft of the engine was stationary and the piston and crosshead were also motionless. The valve traveled back and forward in the steam chest as usual, but moved over plugged steam ports, with the exhaust

cavity open as before. When steam was turned on, the steam chest filled and exerted its pressure on the valve and the only steam which got out of the chest and was taken account of was that due to valve leakage, this steam leaking through went to the condenser and was subsequently weighed as water.

By this means, normal conditions surrounded the valve movement and it is fair to assume that any leakage which occurred now was equal to that which existed when the engine was running in regular service. The first of these tests with the engine standing still and valve moving was with the balance plate on. There was a leakage amounting to 43.9 per cent of the total steam consumption as determined by the first tests, and when the balance plate was taken off and the hole in the top of the valve plugged the leakage under the valve was 13.9 per cent of the steam consumption.

In order to ascertain why there was so much leakage when the valve was balanced, tests were run with the balance plate off, and with varying steam pressures in the steam chest. It was found that the leakage under the valves decreased rapidly as the pressure increased. In other words the tighter the valve was held to its seat the less steam leaked through and this showed that the balanced valve seated more or less imperfectly. It is frankly admitted that the engine had been standing idle for some time and that the valve and seat were not in perfect order, but their condition was not unusually bad. When tested for leaks in the regular way with the valve covering the ports and the throttle open, only a trifling leakage was apparent, and Prof. Stanford is therefore of opinion that the standing test for valve leakage is a very poor index of what may take place when the valve is running.

In order to determine what the balancing of the valve amounted to, the electric motor which ran the wooden pulley attached to the eccentric was calibrated for efficiency and it was found that the power used to move the valve with the balance plate on the 0.25 h. p. and that it practically remained constant for varying steam pressures in the chest. With the valve unbalanced, the power required to drive the valve increased as the pressure on it was increased and that 0.38 h. p. was used in running the unbalanced valve under the normal pressure previously used. In conclusion Prof. Stanford says: "While the saving shown here is light, the value of the balance plate for much larger valves is unquestioned, and no doubt results in a net saving when the parts are in perfect working condition, but it would seem that in a small engine receiving the ordinary care, its presence may become detrimental in the course of time, owing to its tendency to increase the leakage due to poor contact between the valve and seat."

#### Time Table Advertising.

About a year ago the New York Central Railroad sold the "Four Track News," which had been published by the passenger department. An impression had arisen that advertising business given to the magazine was not always voluntary, so the officers of the road sensibly decided that it was the better policy to avoid any appearance of evil.

The example seems to have been infectious, for a press dispatch from Pittsburgh says: Beginning with the January, 1907, issue, the Pennsylvania Railroad will eliminate all advertising from its time tables and guides. This is said to be due to a desire to cut off all appearance of improper profit to employes.

It is said that men in high places on the road have pocketed about \$100,000 a year from the time table advertising. Agents are said to have abused this authority by calling upon firms doing extensive business with the railroad and practically demanding the placing of advertisements at high rates. The advertisements first appeared in the time tables about twelve years ago, and were intended to make the time tables pay for themselves. The privilege was given to several officials, who made a handsome profit.

#### Red Snow.

A few weeks ago an item appeared in the Montreal Witness headed "Fall of Red Snow." The item read as follows: "The Canadian Pacific Railway agent at Glacier, B. C., in the Rockies, has written to the head offices saying that recently several heavy falls of red snow have occurred in that district. This has greatly alarmed the Indians, who regard it as the portent of some dire calamity."

As a matter of fact the red snow is not snow at all and furthermore it does not fall from the sky as snow and rain do. The rosy appearance seen on the mountains is due to the presence of a minute plant, called in scientific language, *Protococcus Nivalis*. It is one of the simplest or lowest forms of vegetable life and is a microscopic Alga, and therefore a sort of first cousin to seaweed. Each cell is about the one-thousandth part of an inch in diameter, but the plant possesses marvelous powers of reproduction, and is capable of spreading rapidly over miles of snow in masses thick enough to be visible at great distances.

It has many times been observed in the Alps and on the Apennines, and was first noticed in 1760 on Mount Breven in Switzerland. It is believed that when this curious little plant has once become established in the snow it may remain there inert until the heat of the sun melts off the layer of snow above it. Then the minute organism, as plentiful as the sand on the seashore, starts at once into vigorous life and growth. The pres-

ence of sunlight appears to be essential to its growth or at least to its color, as the *protococcus* is green when found in darkened fissures of rock or in places where the full radiance of the sun cannot penetrate. At any rate the Indians living in British Columbia need have no apprehension from the appearance of "red snow" on the Rockies.

#### Book Notices.

Questions and Answers Based on the Standard Code of Train Rules, by G. E. Collingwood. Fifth edition. Published by the Train Dispatchers' Bulletin, Toledo, Ohio. Price, postpaid, paper, \$1.00; cloth, \$1.25.

The fifth edition, which has been enlarged and improved, attests the popularity of this valuable little book. It contains the Standard Code of Train Rules for single and double track, rules for the movements of trains on double track, without orders; questions used in examinations, with their correct answers; diagrams of hand, lamp and train signals, etc.; all the rulings of the American Railway Association on train rules.

There is a growing tendency on all railroads towards a rigid examination of trainmen on the Standard Code of train rules, and in consequence there is a need for a good book of reference on the subject. This book contains valuable information in question and answer form on the Standard Code of Train Rules, Rulings of the American Railway Association on doubtful points. It also contains all questions on train rules which have been submitted to the Train Rules Committee of the American Railway Association together with the answers given, which makes it valuable book of reference.

Mr. Collingwood, the author of the book, is a practical railroad man and has always been a close student of train rules. Several years ago, realizing what a great help such a book would be to trainmen, he wrote the first edition of "Questions and Answers," it being the first book on train rules ever published.

He does not pretend that any book on railroading can take the place of actual experience, but this book being the crystallization of experience, and besides containing authentic rulings, which experience does not always furnish. It is an excellent commentary on the meaning of the code and helps any intelligent man to get a knowledge of how to play the game according to the rules which at the present time is a supremely important thing in railroad service.

Railroad Accidents: Their Cause and Prevention, by R. C. Richards. Published by the Association of Railway Claim Agents, 1906. Price, \$1.00.

Safety is the keynote of this interesting

and useful book of 111 pages. The author goes over the melancholy list of train accidents in this country faithfully and from a sense of duty, not for the mere purpose of blaming somebody, but for the purpose of showing not only what was done in the premises but what should have been done. There is no citation of disaster made into a puzzle, with find the culprit attached. He tells the reader what actually took place and how the accident could have been avoided.

When he comes to the part on the prevention of accidents he is frank and honest in stating his views. He believes that the railroad employee is too careless, thoughtless and negligent. He does not scold or say that things are necessarily going to the dogs. He believes that the larger part of accidents which take place could be avoided and that a united effort should be made by all, to prevent them. Mr. Richards clearly sees the futility of crying over spilt milk, but inculcates the lesson of individual effort all along the line for the betterment of railway service. The book deals with a live topic and should be widely read. What we all need to-day is to get down to business and make safety a serious part of the work of conducting transportation. As a help in that direction, *Railroad Accidents: Their Cause and Prevention*, is a timely and useful presentation of the case.

*Proceedings of the Fourteenth Annual Convention of the International Railroad Master Blacksmiths' Association, 1906.* Price, \$1.00.

The report of proceedings of this association held at Chicago, Ill., last August, appears in a handsome octavo volume of 200 pages. It appears from the report that the membership numbers 316, and embraces the leading men in the trade in North America. The report on "Frogs and Crossings," presented by Messrs. Uren and Bimis, showed that much improvement had been made in the methods of construction in the last few years. "Fluc-welding." "Classification of Work in Shops," "Tools and Forms of Bulldozers," are among the papers printed in full, and the reports of the discussions on the same are of much interest.

Papers on "Annealing" and "Case Hardening" also appear, besides a very important paper on the subject of "Best Coal for Use in Smith Shop and Kind of Fires Used," which ought to be read by all interested in the construction of heavy or light forgings. The subject of "Piece Work" is also ably discussed, and the "Making of Locomotive Frames" is presented with a series of illustrations. Altogether the work is one of the best that has come from the association. It is edited by Mr. A. L. Woodworth, Lima, Ohio, and should have a wide circulation

among railway men. The book can be had from this office.

*Switchboards*, by Wm. Baxter, Jr. Published by the Derry Collard Company, New York, 1906. Price \$1.50.

The subject is treated in an able and comprehensive manner by an accomplished expert in electricity who possesses the rare faculty of writing clearly on a scientific subject. The switchboards are fully described and beautifully illustrated, and cover the separate fields of Power, Light and Railway Service, Direct and Alternating Current, and High and Low Tension. In the rapid increase of the uses to which electric power is being put, a thorough knowledge of switchboards is particularly essential to the engineer and others who have to do with switchboards, and we can warmly recommend this work which is a fine example of the printers' and bookbinders' art. The book is of the octavo size, 8 x 5½ inches, 200 pages.

*Railroad Curve Tables*, by R. S. Anderson. Published by The Engineering News Publishing Co., New York, 1906. Price, cloth, \$1.00; flexible leather cover, \$1.50.

The work contains a comprehensive table of functions of a one-degree curve, with correction quantities giving exact values for any degree of curve, together with various other tables and formulas, including radii, natural sines, cosines, tangents and cotangents. There is also added a method of finding any function of a curve of any degree or radius without a field book. The chief merit of the work is its utter freedom from theoretical discussions. The facts are presented in concrete. The work is intended as a supplement to existing field books. The correction quantities are original with the author and are applicable to any function of a curve and are independent of the central angle. The plates from which the work has been printed have been photo-reproduced from the author's original tracings.

*The Walschaert Locomotive Valve Gear*, by W. W. Wood. Published by the N. W. Henley Publishing Co., New York. 150 pages, fully illustrated. Price, \$1.50.

This book is composed of four divisions, the first explaining and analyzing the Walschaerts gear by a simple, illustrated method, setting up the gear piece by piece. In the second division the design and erection of the gear is treated from the scientific viewpoint. Diagrams are furnished from which any machine foreman could lay out the parts of the gear for any size of locomotive, with rules for adjusting the valve. Large folding sheets show the valve gear in nine different positions. The remaining divisions of the work deal with the actual work of the valve gear on the road and a

series of questions and answers complete the work. The author's style is clear and concise and free from unnecessary scientific formulas, and the book ought to have an extensive circulation both among engineers and machinists, all of whom should be familiar with the construction and operation of the valve gearing, which is rapidly coming into favor in America.

*Practical Lettering*, with original system for spacing, complete spacing guide, etc., by F. F. Meinhardt. Published by Norman W. Henley, New York, 1906. Oblong paper cover, fully illustrated. Price 60 cents.

This is an excellent, practical work for the beginner, craftsman, sign painter, or any one engaged in lettering, and shows in brief and intelligent form a rapid and accurate method of becoming a good letterer. The scale illustrated divides the letter into four quarters with a center guide line, and defines the optical proportions of a letter in the most practical way. A proper use of this book would render all preliminary sketching unnecessary, as the absolute accuracy of the system will produce the desired effect. The popular price of the treatise should make it welcome to the student who wishes to learn, to the teacher who has no method for conveying his instructions on "spacing" and to the professional letterer who recognizes his advantage for simplifying and improving his work. The finished samples shown in the work illustrate at once its artistic value, while in matter of detail it presents the first systematic method that has been published.

*Historic Locomotives, and "Moving Accidents"* by Steam and Rail, by Alfred Rosling Bennett, M.I.E.E., with 10 colored plates reproduced from water color drawings by E. W. Twining. Published by Cassell & Co., London. Price, paper, \$1.00; cloth, \$1.50.

Probably the first thing likely to catch the eye in looking over this superb work is the richness and fineness of the reproductions of the water-colored drawings. The artist has finely caught that romantic period of the locomotive's history, beginning about 1846, when the experimental stage had been successfully passed and the machine was beginning to assume a definite shape, rich in coloring and striving to make up for its rough material construction something of that beauty of finish which unfortunately is being lost sight of in our own day. The locomotives of the principal railways in Britain are finely illustrated with the added grace of panoramic views of the green fields and sparkling waters and solemn woods in the glow and glory of summer.

The Derry-Collard Company are the agents in America for this work, but it can be ordered through this office.



# Our Correspondence School

In this department we propose giving the information that will enable trainmen to pass the examination they are subjected to before being promoted. If any of our students fail to understand any part of the instructions, we will gladly try to make them plainer if they write to us. All letters intended for Our Correspondence School ought to be addressed to Department E.

## Third Series—Questions and Answers.

205.—How shall work train extras be run?

A.—They must be run on orders from the train dispatcher.

206.—What precautions are necessary when approaching a station where a train is receiving or discharging passengers?

A.—The approaching train must be under control. Enginemen must keep a sharp lookout for switches and signals and be prepared to stop on hand signal.

207.—What persons are permitted to ride on engines?

A.—Answer according to the special rule of the railway company.

208.—Who is responsible for the switches when there is no switch tender?

A.—The conductor of the train using the switch.

209.—May you leave a switch open for a train or section that is following you?

A.—No, switches must be left in proper position after having been used. A switch must not be left open for a following train unless in charge of a trainman of such train.

210.—How must all accidents, detentions to trains, failures in the supply of water and fuel, and defects in track and bridges be reported?

A.—Answer according to the special rule of the railway company.

211.—May a train leave a station with a signal from its conductor?

A.—No.

212.—Are conductors and enginemen equally responsible for the safety of their trains and for the observance of the rules relating thereto?

A.—Yes.

213.—What course should be pursued in case of doubt or uncertainty?

A.—In all cases of doubt or uncertainty the safe course must be taken and no risks run.

214.—For what are special orders to be used?

A.—For the movements of trains when such movements are not provided for in the time table, and for the conveyance of instructions to trainmen and enginemen or operators.

215.—By whose authority and over whose signature are they issued?

A.—Answer according to the special rule of the railway company?

216.—Would you accept an act upon an order in which there are erasures, alterations or interlineations?

A.—No.

217.—How must they be addressed?

A.—Orders must be addressed to those who are to execute them. Those for a train must be addressed to the conductor and engineman and also to anyone who acts as its pilot.

218.—Who must have copies?

A.—Each person addressed must receive a copy of the order.

219.—What do the terms "superior right," and "inferior right" in the rules refer to?

A.—The term "superior right" is used concerning a train which is given preference by train order. "Inferior right" is used concerning a train which it not given preference by train order.

220.—Who are required by the rules

A.—Trainmen and firemen must read and understand the orders in addition to all to whom the order is addressed.

224.—Upon whom does the duty devolve of seeing that the men read and understand the orders?

A.—Answer in accordance with the special rule of the railway company.

225.—After "O. K." has been given and acknowledged and before "complete" has been given, how is order to be treated?

A.—It must be signed by those to whom it is addressed, except the enginemen, and the signatures must then be sent to the dispatcher.

226.—If the telegraph line fails before the operator has received and acknowledged an "O. K." to an order, how is the order to be treated?

A.—The order at that office is of no effect and must be treated as if it had not been sent.

227.—In what way does a "19" order differ from a "31" order?

A.—The difference between a "19" and a "31" order is that a "19" order is not signed by those to whom it is addressed, but "complete" is given by the dispatcher when the order is repeated, and a copy of the order must then be delivered personally by the operator to each person addressed. The "31" order must be signed by those to whom it is addressed, except the enginemen.

228.—Is there any restriction on the use of a "19" order? If so, state it.

A.—Answer in accordance with the special rule of the railway company. Under the Standard Code rules there is no restriction placed on the use of the "19" order.

229.—If the telegraph line fails before the operator has received and acknowledged the "complete" to the "19" order, how is the order to be treated?

A.—The order must be treated as a holding order for the train addressed, but must not otherwise be acted upon until "complete" is given.

230.—What must conductors do with orders that have been used by them?

A.—Answer in accordance with the special rule of the railway company.

231.—If an engineman is in charge of a train, what should he do with his orders after they have been executed?

A.—Answer in accordance with the special rule of the railway company.

232.—Where must enginemen place their orders before they have been executed?



PIKE'S PEAK RAILWAY ENGINE, CAR AND PORTION OF TRACK SHOWING RACK RAIL.

to sign their names to the copy of the order retained by the operator?

A.—Those to whom the order is addressed except the enginemen.

221.—What entries must be made on an order before it can be acted upon?

A.—For a "31" order, the signatures of those to whom it is addressed, except the enginemen, also the word "complete" with the time and the last name of the operator written in full must be upon the operator's copy of the order before it can be acted on.

222.—What are the requirements with reference to reading orders?

A.—Answer according to the special rules of the railway company.

223.—What other persons are required to read and understand these orders before they are acted upon?

A.—Answer in accordance with the special rule of the railway company.

233.—State fully the method provided for the delivery of special orders to trains at points where there is no telegraph office.

A.—A train order may be delivered to a train at a point not a telegraph station, or at one at which the telegraph office is closed. When this is done the order must be addressed to "C and E . . . . . (at . . . . .), care of. . . . .," and it must be forwarded and delivered by the conductor or other person in whose care it is addressed. When the order is a "31," the dispatcher will give "complete" upon the signature of the person by whom the order is to be delivered, and this person must be supplied with copies for the conductor and engineman addressed, and also a copy upon which he shall take their signatures. This copy he must deliver to the first operator accessible, who must preserve it, and at once transmit the signatures of the conductor and engineman to the train dispatcher. Orders so delivered must be acted on as if "complete" had been given in the usual way.

For orders which are sent as here described, to a train the superiority of which is thereby restricted, "complete" must not be given to an inferior train until the signatures of the conductor and engineman of the superior train have been sent to the officer designated by the railway company.

234.—What is meant when a train is named in an order and no particular section or sections specified?

A.—When a train is named in an order, all its sections are included unless particular sections are specified, and all the included sections should have copies of the order.

Parallelogram of Forces.

BY G. S. H.

If a football lying on the ground is kicked at the same instant by two players, one kicking due north and the other due east, the ball will be seen to fly off at an

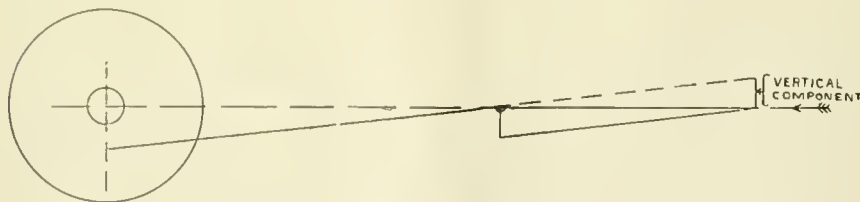

RESOLUTION OF FORCES FROM THRUST OF PISTON ROD.

angle to both these directions. If the kicks are of equal intensity and delivered squarely on the surface of the ball it will be found to travel in a northeast direction, and the force with which it moves is called the resultant of the two forces applied in the kicks of the players.

This may be shown graphically and

without going to the trouble of an experiment on the gridiron field by the use of what is known as the parallelogram of forces. This principle is usually stated by saying if any two forces acting upon a body are represented in direction and intensity by the adjacent sides of a parallelogram which passes through their point of intersection.

In order to make this clear, suppose we represent it on a drawing board, taking the equivalent of the northerly impulse applied to the football as a force of 50 lbs., and laying of a line 50 ins. long, that being one inch to the pound. We also lay off a line 50 ins. long at right angles to the first, and on completing the parallelogram, we draw the diagonal which will pass through the point where the ball was supposed to have lain before being kicked. The length of the diagonal measured by the one inch to the pound scale will give us the equivalent in pounds of the resultant force and the direction of the diagonal will represent the line along which the resultant force acted. Any scale may be used, but it is necessary to measure all the lines by the scale chosen in order to get correct results.

Supposing the northerly kick to have been equal to 4 lbs., and laid off as a

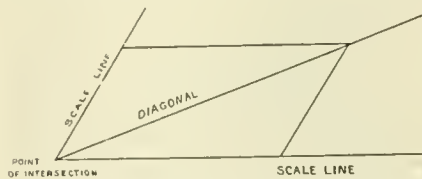

GRAPHIC REPRESENTATION OF FORCES.

line 4 ins. long, and that the eastward force was only 3 lbs., represented by a line 3 ins. long. The diagonal would measure just 5 ins. long on the same scale. The resultant would be found in this way to be 5 lbs. in intensity, and the direction is given with perfect accuracy by the diagonal. It would be found to approximate closely to the direction which sailors would call northeast-by-north. This method of operation is called the

composition of forces and the reverse operation by which one force represented by a line drawn to scale, is shown to be equivalent to two other lesser forces also represented by lines drawn to the same scale, is called the resolution of forces.

This method of resolving a force may be made use of in determining the up-

ward pressure of the crosshead of a locomotive at any point of the stroke, all we require to know is the amount of the force applied from the cylinder along the piston rod and the angle at which the connecting rod stands for the position we want to determine. If we lay off a line accurately to scale, representing the force pushing or pulling the cross head, and through one end of this line lay off another of indefinite length, but

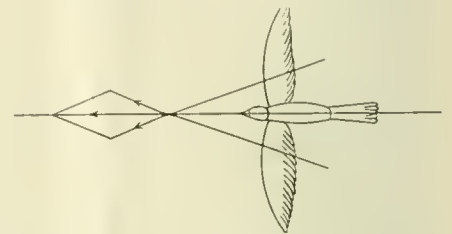

FORCES OPERATING IN BIRD'S FLIGHT.

at the angle made by the connecting rod at, say, the bottom quarter, and through the same point, we lay off another line of indefinite length at right angles to the first (as we know the cross head moves horizontally and the pressure on the top guide bar is vertical), then we have the directions of the two forces into which we have resolved the one acting along the piston rod. On completing the parallelogram, and using the same scale to measure them by, we will at once ascertain their magnitude.

In the diagram it is evident that the longer the connecting rod is, the smaller the angle it makes with the piston rod when the pin is on the bottom quarter, and the less will be the upward pressure on the top guide bar. This is shown by the short upright line representing the vertical component. The shorter this vertical line is in comparison with the line representing the thrust of the rod, the better it is, because most of the push of the piston is used to turn the wheel, and very little to press on the top guide bar, and herein lies the secret of the advantage of having a long connecting rod.

Some interesting examples of the principle here involved may be found in nature. It is well known that a bird wounded so as only to be able to use one wing will beat its way in a wide circular course, gradually sinking down by reason of its imperfect flight. The stroke of the single pinion on the air carries the bird slightly over to one side and compels it to sweep out a somewhat inclined path. When both wings are used the resultant of the inclined direction produced by each wing separately causes the bird to move forward in a straight line as if impelled by the action of a single force.

The progress of a sailboat acted on by a wind on the quarter is capable of analysis by the parallelogram of forces, and if the force of the wind be represented by a scale line laid off on the

drawing board and if the angle at which it strikes the boat be known the headway made by the craft and the amount of leeway caused may be ascertained with approximate accuracy. An allowance would, in this case, have to be made for the fact that the vessel sails straight ahead much more readily than keel and hull can be pushed sideways through the water, but the parallelogram of forces if correctly applied will give exactly the direction and the intensity of each component force, even though the resistance to motion in the water is different for the forward course and for leeway.

## Questions Answered

### DRAFT WITH ARCH AND LOW DIAPHRAGM.

(1) H. S. R., Middletown, N. Y., writes:

Speaking of an engine equipped with a "Bates" fire door, brick arch of which the front end is against the flue sheet, extending back 6 ft.; length of box, 9 ft. 6 ins.; diaphragm plate in smoke box uncovering about 6 rows of flues; no draft pipe used. A claims draft is greater and the velocity of the gases is higher through the lower flues, because of the partial vacuum created in the smoke arch which will naturally be supplied or get a greater supply through lower flues on account of the position of the diaphragm, also the wear of the bead on the lower flues will be more, and the fact that the lower flues become more fouled by cinders, etc., proves that the current through the lower flues is greater than through those above. B claims that draft is stronger and the velocity of the gases is greater through the top flues because they do not become fouled with cinders, and that the current of hot gases as they turn over the arch would naturally go to the top flues. Which is right? A.—In this case B is right. As the diaphragm does not cover the top flues there is that much less obstruction to the free passage of fire box gases to the stack through them, and the deflection of the current in the fire box caused by the arch would tend to carry the gases toward the top flues. The fouling of the lower flues by cinders, etc., is caused by there not being sufficient draft to keep them clean and the wear of the bead of the lower flues is probably caused by the dancing up and down of cinders, which get on top of the arch and move down to the comparatively slack space where the arch touches the flue sheet, and where there is something like the eddy in a stream of running water behind a stick held in the current.

### TESTING AIR VALVES CROSS COMPOUND PUMP.

(2) J. C. D., Jackson, Mich., writes: How can we test the air valves in the cross compound pump so as to tell wheth-

er they leak or not? A.—To test the air valves in the cross compound pump to determine whether they leak or not, proceed as follows: Run the pump until you have eighty or ninety pounds pressure, then ease up on the throttle until you have the pump running at, say, fifty or sixty cycles per minute. Say that it is the upper set of air valves you wish to test. Begin by placing the hand near the upper air strainer when the low pressure air piston is making its up stroke. If the upper inlet valve leaks air will be felt blowing back through this strainer and probably it will be noticed, if the leakage is considerable, that the piston makes a quicker stroke toward the leaky valve than it does away from it.

If the upper intermediate air valve leaks appreciably the leakage will be manifested by an unevenness in the strokes of the pistons, the low pressure piston making a quicker down, and slower up, stroke than normally, and the high pressure piston a quicker up, and a slower down, stroke than normally. There will also be a weaker suction at the upper air inlet valve.

When the upper final discharge valve leaks appreciably it will cause a quicker down stroke of the high pressure piston, and a slower up stroke of the low pressure piston, with a tendency to weaken the suction at the upper air inlet valve.

For each corresponding air valve of the lower set the same is true when it leaks and the piston movement is similarly affected, only on opposite strokes.

All air valve leakage has a tendency to cause the pump to heat more than it ordinarily should, and to produce irregularity of pump strokes.

### INJECTOR ACTION.

(3) C. R., Johnstown, Pa., writes:

We have two engines and I have fired both. When you put on the injector of No. 27 it kills the steam pressure. It goes down 25 lbs. in less than five minutes. It does not matter how hot she is when the injector is started, the pressure goes down. On No. 28, with same size of injector, that is, 10½, the steam does not go down. What is the cause of this? A.—The reduction of steam pressure referred to may be caused by a difference in the method of operating the injectors on to the engines or by a difference in the way the engines themselves are worked. If, in the one case, the injector is operated with the water valve cut down fine and in the other case with the water valve fully open, then the steam pressure will be affected less in the former than in the latter case. Again, if the engine is worked light and the fountain in the cab sufficiently large to fully supply not only the injector, but other appliances connected with the fountain, the steam pressure will be a little

affected by the injector. In case, however, that the engines are worked hard and the injector put on at the same time, the steam pressure is liable to go down. With properly made injectors there should be nothing in the injectors themselves to cause this difference of pressure, unless it be that one of the instruments may be so worn in the steam nozzle that it consumes considerably more steam than it would if in proper condition.

### BEHAVIOR OF WATER GLASS.

(4) H. S. R., Middletown, N. Y., writes:

With a Wootten type boiler water gauge glass, cocks tapped into the cylindrical part of the boiler, direct into the round shell in the forward cab, in the usual place; while standing still, filling boiler with injector on, the water glass will not completely fill up, it will stay about half an inch from the top nut as long as the injector is working, regardless of how high the water may be above it in the boiler. When the injector is shut off, water will immediately go up out of sight, and the chances are the boiler is so full you cannot move the engine. A.—This is probably caused by the part of the top gauge glass mounting being tapped in so far in the circular part of the boiler that the shank goes below the water level, due to the angle at which the mounting is put in, and a little steam is trapped in the glass at its upper end. An inaccurate water level indication is a dangerous thing. Have the upper gauge mounting examined and see if shank is too long, and blow out the glass several times during the progress of filling up.

### K TRIPLE ON SINGLE CAR.

(5) E. L. B., Chicago, Ill., writes:

If you have only a single car attached to the engine, and that car has a K triple, won't a heavy service application be apt to make the triple "dynamite"? A.—No, a heavy service application under the conditions you cite will not be so likely to produce quick action with the K triple as with the present standard triple. The reason for this is, the triple piston has to move far enough to compress partially the graduating spring before the graduating valve opens wide the service port; and when the slide and graduating valve are in position to open the service port wide, they close entirely the quick service port between the brake pipe and the brake cylinder, thus cutting down the rate of brake pipe reduction. It will be easily seen, therefore, that when the service port is wide open and the graduating spring at the same time is under compression, a heavy service reduction cannot cause, even with a single car, undesired quick action.

### BRAKES TO SUIT LOAD.

(6) J. R. R., Syracuse, N. Y., writes: Has there ever been a brake made or

tried that successfully worked so as to brake a car according to the load it had? A.—Not that we know of, unless a brake that is cut in by hand to add extra braking force, when the car is loaded, and cut out by hand to reduce the braking force when the car is empty, is considered such. The nearest approach to an automatic working brake of this character is had with the style K triple valve, and this automatic variation of braking power on the loaded cars over the empty is due to the fact that the loaded cars are likely to be placed near the head end of the train.

#### CYLINDERS, LINKS AND MAIN PINS.

(7) C. R., Johnstown, Pa., asks:

1. What are cylinders on an engine for? A.—The cylinders are the vessels or chambers in which steam is confined when acting on the pistons to make the engine move.

2. What are the links for? A.—To facilitate the reversing of the engine.

3. Will an engine lift its own weight off the rail when it slips? A.—No. Read article on "Some Slippery Engines," on page 208, of the May, 1906, issue of RAILWAY AND LOCOMOTIVE ENGINEERING.

4. What shape is the main pin when an engine slips? A.—The main pin does not alter its shape when an engine slips. If you want to know the position of the main pin when an engine slips, read "Cause of Engines Slipping," in the June, 1906, issue of RAILWAY AND LOCOMOTIVE ENGINEERING, page 251.

5. Why are links on an engine called links, why not call them something else? A.—The links are so called because in a way they resemble a link in a chain, they have two side pieces and closed ends. They also serve to join or link together the forward and back eccentric rods. The name is a good one, universally understood, and there is no good reason for changing it. You ought to get some books on the locomotive and study up the whole subject. Forney's "Catechism of the Locomotive," and Angus Sinclair's "Locomotive Engine Running and Management" will help you.

#### WITHOUT PRESSURE RETAINERS.

(8) C. A. S., DuBois, Pa., writes: read a statement in the Air Brake Proceedings, made by one of the members, stating that in heavy grade work where they had the train equipped with the quick service triple valve the train could be brought down safe without the use of the pressure retaining valves, and still have plenty of braking power at any place on the grade. Looking at the triple valve itself I am not able to see how it can make it possible to dispense with the retainers in heavy grade work. Will you please explain this feature? A.—The statement you refer to is probably one that was made concerning a test of the K

triple on a 90-foot grade, 11 miles long. Beginning the descent of the grade pressure retainers were used, but before proceeding far it was found the train could be handled all right without them.

The reason the K triples can take trains down grades without pressure retainers is, when applying the brakes all of them go on very much quicker, with a more uniform and a higher pressure for the first 5-pound service reduction, than they do with the ordinary standard triple. This makes the retarding power more effective. Because the triples vent brake pipe air into the brake cylinder in service application, less air is required to recharge the auxiliaries when the release is made, and because of the retarded release features operating on the first 30 or more cars in the train they act practically as an automatic pressure retainer. Hence in the combination of quick application, economy in air used, and the retarded release of so many of the head brakes, it was found in the test referred to that the pressure retainers were not necessary.

#### RULE TO CALCULATE FREE AIR IN RESERVOIR.

(9) C. B. C., Harrisburg, Pa., writes: Will you please give the rule, in the columns of your journal, to calculate the number of cubic feet of free air contained in a reservoir of a given volume for any given pressure? A.—Divide the absolute pressure in the reservoir, which is the gauge pressure, plus 14.7, by 14.7, the pounds pressure of one atmosphere, to determine the number of atmospheres it contains. Multiply this quotient, or result, by the volume of the reservoir, in cubic feet, and you will obtain a result showing the number of cubic feet of free air the reservoir contains.

Example: A reservoir of 53,600 cubic inches is charged with air to a pressure of 90 pounds gauge. How many cubic feet of free air does it contain? The absolute pressure is  $90 + 14.7 = 104.7$  pounds.  

$$\frac{104.7}{14.7} = 7.15$$
 The number of atmospheres is — = 7.15 atmospheres. The volume in free air is  $7.15 \times 53,600 = 383,240$  cubic inches. In  $\frac{383,240}{1728} = 22.2$  cubic feet this equals — = 22.2

To calculate the capacity of a reservoir (its dimensions are usually given in inches, outside measurement), first subtract from its length 3 inches, and from its diameter  $\frac{1}{2}$  inch, to get its inside dimensions.

Square the inside diameter, that is, multiply it by itself, and multiply this result by the decimal .7854. This gives the area of the head. Multiply the area of the head by the length in inches, and the result will be the volume, or capacity in cubic inches. To reduce this to cubic feet, divide by 1728, the number of cubic inches contained in one cubic foot.

#### Drill Press Hints.

The proper running of a drill press is a much more important job than it is generally believed to be. The idea that anybody can run a drill press is a gross error. Long experience and close observation is necessary to become familiar with speed limits and cutting angles and the lubrication of drills, not to speak of the numberless details of adjusting and clamping work. It is a noteworthy fact that in drilling work that is not clamped down on the table and where the stop point or holder against which the work is steadied, is to the left of the drill point, the tendency of the hole being drilled, is to creep towards the side nearest the upright post of the machine. A few of the more experienced machinists know how to make allowance for this by drawing the center towards the outer side.

On a sloping surface the center of holes should be drawn to the higher side before the operation is begun, and it is very helpful on uneven surfaces to drill a small hole as a guide for a larger drill, which will run true to the small hole. In enlarging holes it is dangerous to attempt to enlarge a hole with a twist drill. Only flat drills should be used in increasing the size of holes, that is, when there is only a small amount to cut out. In the case of a small hole merely intended as a central guide, a twist drill of a much larger diameter can be used effectively.

In regard to increasing the size of holes by the usual process of running a rose bit through, the work should not be clamped to the table until the rose bit has begun to work in its true center, otherwise it is very difficult to locate the true center, and the hole instead of being straightened, may be completely spoiled. In drilling holes for tapping there is usually a table showing the sizes of drills to be used for certain sizes of taps, but in addition to these it may be noted that in drilling for permanent screws or tap bolts that are not likely to be disturbed, a larger size of hole may be drilled than for operating screws where the thread must necessarily be full and perfect.

It may be added that the tendency of the present time in the principal machine shops is towards making "jigs" for every class of work where exact duplicates are required. The inclination to make "jigs" is the one distinguishing mark of the factory-bred mechanic. It gives a perfection of work that no mere careful watchfulness can ever hope to rival. Jigs with hardened bushings pay for their construction in a very short time. There are no spoiled holes, no large holes to be tapped and plugged up and drilled again. There are no useless and wasteful reamings. Jigs are appliances that lead toward perfection in drill press work. In high class work jigs are not merely a convenience, they are a necessity.

# Air Brake Department

CONDUCTED BY J. P. KELLY

## Holding Power of Straight Air.

Several times during the past year we have been asked to give our opinion concerning the capacity of the straight air brake as a retarding power, and to give an estimate of the length of the train it can hold bunched sufficiently to prevent a break-in-two when the automatic brakes are released at slow speeds.

The following we think will answer these queries as far as it is possible, and

as the compressing force is removed.

This stored spring energy, together with the free slack in the train is what the straight air brake must take care of when the train brakes are released, but to do this it has a limited retarding power, the amount of which depends on the weight of the locomotive and the force at which it is braked; and it is possible to calculate it with a reasonable degree of accuracy. The following will serve to illustrate:

It will be clear that it is next to impossible to determine, except by practical test, how long a train of cars this amount of force can hold bunched safely so that release of the brakes while moving slowly can be made without danger of parting the train, because of the varying amounts of free slack and draft gear compression, train make up, etc. Experience shows, however, that the limit lies between fifty and sixty cars.

No doubt the brakes may be released on



MODERN STEAM POWER WITH AIR BRAKES. C. R. R. OF N. J. TERMINAL AT HOBOKEN, N. J.

Taken for *Railway and Locomotive Engineering*.

By F. W. Blauvelt, New York.

it will give our readers ideas about the straight air brake that will be of practical value.

To begin we are safe in saying that the straight air will hold the slack in a train consisting of not over fifty-five cars sufficiently well to prevent serious shock or a break in two when releasing, but when the number increases materially beyond this, the safer plan will be to stop before releasing. It is a matter of common observation that long trains will bunch up toward the head end when a service application is made, and in doing this they compress the draft gear springs. These springs have capacities as high as twenty thousand pounds, that is, it requires this amount of pressure to compress them solid; they do not destroy this pressure or energy, but give it out again, as soon

For a locomotive weighing two hundred thousand pounds on the drivers the braking force, taken at sixty-five per cent of this weight, will be one hundred and thirty thousand pounds, and the actual retarding force, when the locomotive is moving at a rate of ten miles per hour, will be about twenty-four per cent of this, or thirty-two thousand, five hundred pounds. Adding to this the retarding power of the tender, which may be taken at about fourteen thousand, six hundred pounds, making a total of forty-six thousand, one hundred pounds, we have the total retarding effort the locomotive exerts on the train when moving at the speed mentioned with the straight air brake fully applied, and it is the force that must be depended upon to prevent break in two when brakes are released.

trains consisting of considerably more than sixty cars without breaking them in two, provided all coupler knuckles, end sills and draft timbers are in good condition, or if a considerable number of the cars are equipped with friction draft gear; but it is likely that severe shocks on trains of more than fifty cars would be produced that would damage the draft gear sufficiently to invite break-in-twos at another time.

As the tractive effort of a locomotive and the actual retarding power of the straight air brake are always in about the same ratio, if we take about twenty-three per cent of the weight on the drivers we shall always get a very close estimate in pounds of just what the straight air brake is capable of exerting as a retarding power, for any locomotive.

This applies though only to locomotives whose tenders are equipped with straight air. There are a few engines now in service that do not have the straight air on the tender; for these the retarding effort should be taken at fifteen per cent of the weight on the drivers.

In the case of the locomotive weighing two hundred thousand pounds on the drivers, which we have used for illustration, it will require an effort when it is standing, with the straight air brake applied, of sixty thousand, six hundred pounds to start it. Therefore, this engine would

the steam locomotive, to fit it to the needs of the electric type, and to substitute for the steam-driven air compressor and the compressor governor electrically driven and operated apparatus that perform similar functions.

In order that our readers may keep posted on the changes necessary in the automatic brake to adapt it to electric service we illustrate in this issue the method of piping an electric locomotive, and in future issues we shall illustrate and describe the electrically driven and operated apparatus.

then be taken to the end facing the direction in which the locomotive is to run and be replaced on the other set of brake valves. These handles can only be removed when the brake valve rotaries are on lap.

It will be noticed that there are three train pipes instead of two, as is the custom with the steam locomotive. Two of these train pipes comprise the well-known automatic brake pipe and the air signal pipe, while the third, called the main reservoir pipe between locomotives, serves

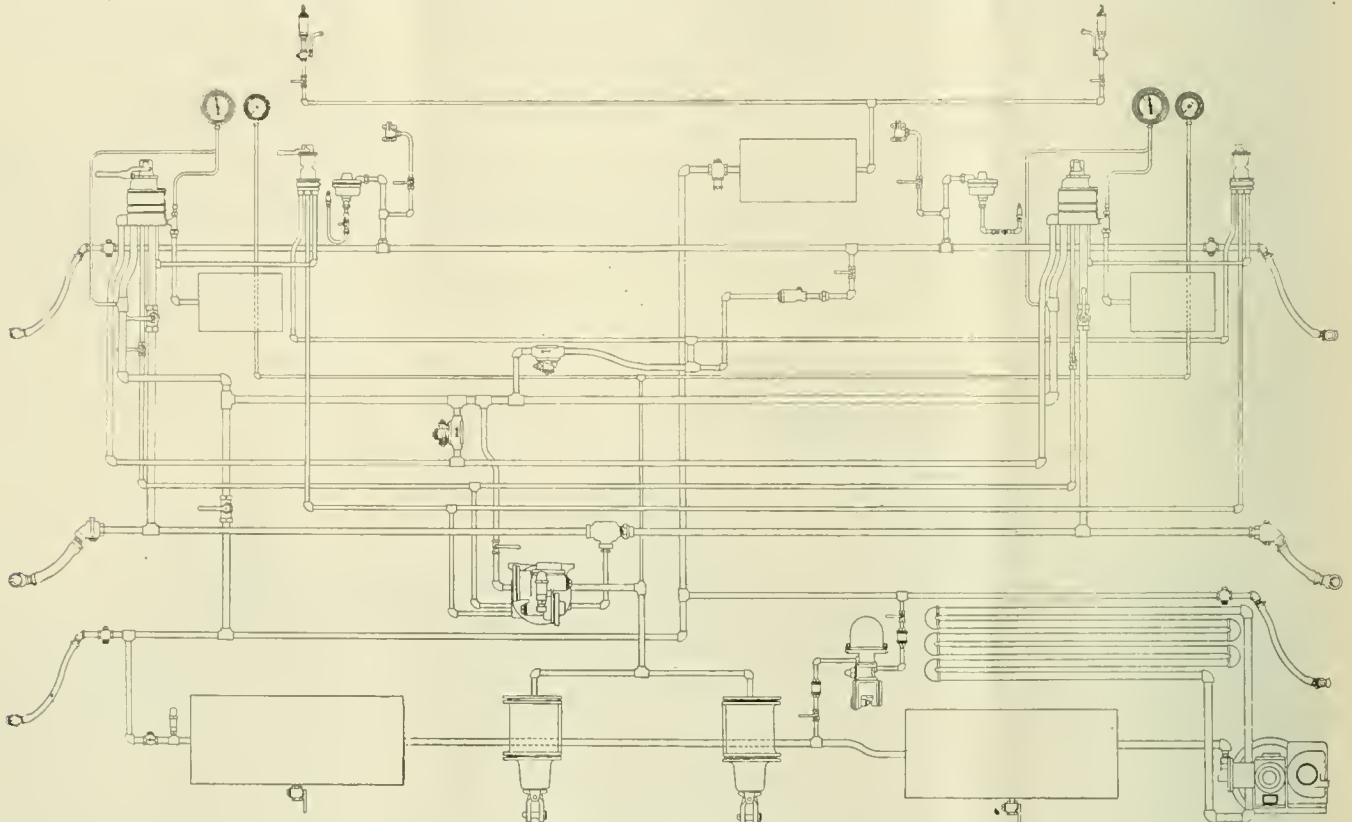

ARRANGEMENT OF AIR COMPRESSOR, RESERVOIRS, PIPES, CYLINDERS, ETC., ON ELECTRIC LOCOMOTIVE.

be capable of holding on a grade of two per cent a train whose total weight is three million pounds, or a train of twenty one-hundred-thousand-pound capacity cars. To do this, of course, would require that the train be bunched against the locomotive, if it is in front of the train, or that it be stretched, if the locomotive is in the rear, at the moment of stopping. A practical test of this would probably show that a few more cars than the number given above could be held standing on a two per cent grade, since no account of the friction in the journal boxes and other parts was taken into account in the estimate given above.

**Air Brakes on Electric Locomotives.**

The introduction of the electric locomotive into service on steam roads has made it necessary to modify somewhat the piping arrangement of the present standard automatic apparatus, as used on

The diagram above shows the parts necessary for a double end locomotive and how they are connected up. A little careful inspection of this diagram shows that the equipment is practically the Westinghouse E T, now installed and in successful operation on hundreds of steam locomotives, but that each end is supplied with a set of brake valves, air signal valves, air gauges, air whistles and so forth. The air brake schedule, as applied to the electric locomotive, is called the E L.

The large whistle used for station and grade crossings will be blown by air, and there is a separate reservoir provided to hold a supply for this purpose.

The brake valves differ from those on steam locomotives, in that they have removable handles. When the direction of the trip the locomotive is to make is determined all apparatus in one end is cut out, the brake valves placed on lap and the handles removed. The handles may

when two or more locomotives are coupled together to unite the main reservoir on each and make their combined volumes available for use by the engineer through the brake valve he is operating. It also causes the electric pump governors to cut in each compressor and make it do its share of the work. With this arrangement there will always be an abundant supply of air without overworking any one compressor. Between the compressor and the first reservoir there is a cooling coil of pipe. The air discharged from the compressor must all pass through this pipe before it enters the main reservoir; hence the compressed air will be cooled down when it reaches the reservoir, and it will practically deposit all of the moisture it contains in suspension before passing back through the brake valves.

The course of the air through the brake system is the same as that of the standard locomotive equipment, familiar to all engineers, so that no trouble will be experi-

enced in grasping a knowledge of this point.

The names assigned to the different pipes are as follows:

Main reservoir pipe, main reservoir pipe between locomotives, feed valve pipe, brake pipe, application chamber direct, application chamber through slide valve exhaust cavity, supply pipe to independent brake valve, brake cylinder gauge pipe, main reservoir connecting pipe, signal pipe, whistle pipe, brake cylinder pipe, equalizing pipe, and cooling pipe.

The electric locomotives of the N. Y., N. H. & H. R. R. are equipped as shown in this diagram, and this method is practically the one, except for slight changes that may be made to suit local conditions, that will be followed on all other similar locomotives.

No. 1 the side tool of No. 2 took a cut. When the work was done they turned the hammer leg end for end and planed off the top face. Thus were two planers made to do the work of one and the

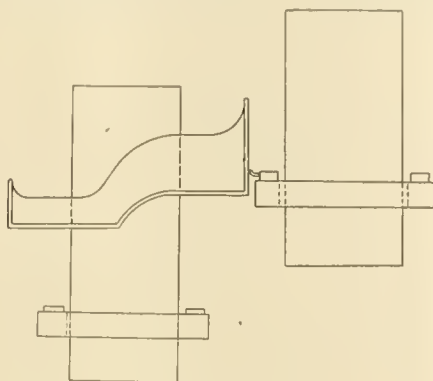

WORK CARRIED ON ONE, PLANED BY THE OTHER.

whole thing went beautifully and everybody was pleased. Now you can easily see that it was owing to the juxtaposition of the two machines and their "echelon" arrangement which made the operation possible, but at the time nobody in that shop used these words to express their ideas.

**Interurban Line in Texas.**

Contracts have been let by the Texas Traction Company for the equipment of a sixty-five mile electric road between Dallas and Sherman, Texas. The new line will parallel the existing steam road between the two cities, and will be one of the longest electric roads in the State. While the apparatus is standard, direct current throughout, the equipment, in some respects, presents several features of interest.

The country through which the new line is laid out is flat and rolling, there being no grades exceeding 1 per cent. and a maximum curvature of but three degrees. In order to have a clear headway for operating cars, a private right-of-way has been established by the company, so that the run between Dallas and Sherman will be made in two hours and thirty minutes. This schedule includes a fifteen-minute run within the city limits of Dallas, where the cars must necessarily move at lower speeds. While the main traffic will be express, stops have been provided about every two miles to facilitate local travel.

Fifteen car equipments will be provided to maintain the initial schedule. These will be of the standard interurban type, each fifty feet long, and equipped with four 75 h. p. standard direct current motors, equipped with the Sprague-General Electric system of multiple unit control. Each car will be further provided with General Electric air brakes and compressors. Power for the new road will be generated by steam at McKinney, a

town located about midway between Dallas and Sherman. The main power station equipment will include two 1000 kilowatt Curtis steam turbo-generators, working under a steam pressure of 150 lbs. at the throttle with 125° superheat. The turbines will operate with condensers. Current will be generated at 2,200 volts and stepped up for transmission to 19,100 volts. The three-phase current from each of the turbo-generators will be transformed in a set of three, 330 kilowatt, air blast transformers. One transformer of the same capacity will be installed as a reserve.

One of the special features of interest in the new road lies in the rotary converter equipment. Six sub-stations will be provided, including one at the main station and a portable equipment. This last mentioned sub-station comprises a special car containing a 300 kilowatt rotary converter, air blast transformers, and suitable switching apparatus for cutting into the transmission system wherever necessary. The portable sub-station renders unnecessary the duplication of rotary converters at the fixed sub-stations, for the portable equipment can be shifted to various parts of the line and used as an emergency station or auxiliary in case of need. Regular sub-station equipments are to be provided at the main station and at four points distributed along the railroad. Each of these sub-stations will be quipped with a 300 kilowatt 600 volt rotary converter, with the necessary switchboards, oil-cooled transformers and lightning arresters.

**Piston Rod Puller.**

Our illustration is taken from a sketch sent us by Mr. John F. Long, division foreman on the St. Louis and San Francisco Railroad, at Beaumont, Kan. The operation when using this apparatus consists of taking out the wrist pin and inserting the short piece against the end of the piston rod, then putting the larger

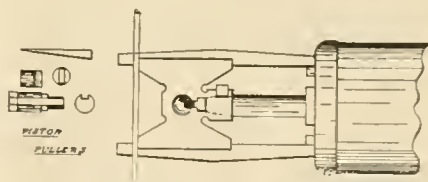

PISTON ROD PULLER.

piece in the place formerly occupied by the wrist pin.

The short piece has an edge which fits partly into the keyway in the temporary wrist pin. When all is ready a taper key is driven in and a few blows of the hammer produce pressure enough to start the piston rod out of the crosshead, and when a taper key is placed as it is here and driven in where nothing can slip or break something has to give, and the piston rod and crosshead part company very quickly.

**Echelon and Juxtaposition.**  
It so happened some time ago that a railroad repair shop had a piece of awkward work "put up" to it, which was handled in good shape. The job was to plane off the bottom and top faces of a steam hammer leg. The leg was about 12 ft. long, and no planer in the shop would hold it and do the work, because the leg had to be laid across the planer-table and then it was too wide to go between the housings.

For a while nobody knew what to do until the machine shop foreman bethought him of a way. There were two cylinder planers in the shop and they stood side by side. That is, the planer tables moved parallel to each other and were about three or four feet apart. Moreover, these machines were arranged "en echelon," as military men would say. One tool was a few feet farther ahead than the other, or one was farther back than the other, if you choose to say it that way.

The machine shop foreman, after thinking hard while the second hand of his watch made several complete revolutions, had the hammer leg laid across the table of the planer which was the farther back of the two. The foundation end of the leg overhung the table about three feet or more and the upper end of the leg overhung the other side of the planer table. The hammer leg was secured in position and the side tool on the adjacent post of the other cylinder planer was got ready for business.

When things were adjusted the planer which carried the hammer leg was set in motion and carried the leg backward and forward the length of the cut on the foundation end face. It carried the leg almost up to its own housings, but just cleared, and so the requisite motion of the work was secured on planer No. 1. The side tool of planer No. 2 was run up the required height, and was fed down by hand, and at each stroke of planer

# Electrical Department

With this issue of RAILWAY AND LOCOMOTIVE ENGINEERING begins an Electrical Department. This we believe will be appreciated by our large and increasing number of subscribers. We will endeavor to give our readers the benefit of the latest electrical information, both in theory and practice, and we will answer questions pertaining to the construction and operation of electrical appliances used on railways. We shall be glad to receive correspondence and notes on shop kinks on electrical subjects.

### Electric Switcher.

The American Locomotive Company have recently completed a 37½-ton elec-

trical switching locomotive for the General Electric Company, of Schenectady. The locomotive is designed for operation on a 250-volt circuit and the rated tractive effort is 15,000 lbs. at about 8 miles per hour. The rated tractive effort is practically the force it will exert while operating under normal conditions for one hour at a 75° F. rise in temperature. The instantaneous draw-bar pull for starting purposes is about 18,800 lbs. This is really the maximum tractive effort, but could not be kept up indefinitely without danger of damage to the motor through over heating. In which case the current becomes short circuited, and the motor burned out. This maximum figure is limited by two things: One is the maximum overload capacity of the motor and the slipping point of the wheels. In practice, the slipping of

the wheels is what actually determines this maximum instantaneous draw-bar pull, because as direct-current motors are generally designed the wheels will slip before the overload becomes so great on the motors as to make the current flash or jump at the commutators. The instantaneous or starting draw-bar pull is analogous to the calculated maximum tractive effort of a steam locomotive and the rated tractive effort of the motor is like the draw-bar pull which the same engine will give when notched up. The running gear consists of two American Locomotive Company's four-wheel, arch-bar frame trucks with cast iron floating bolsters. Each truck is

equipped with two 175 h. p. General Electric Company's type 68-B direct-current motors. The motors are inside hung, with half the weight carried on the axle and half by nose suspension from the truck frame. The locomotive is arranged for single unit control. This means that if it were coupled in a train which had motor cars in it, these motor cars could not be operated from the electric switcher. In fact, this machine is like a steam locomotive in respect to hauling cars. That is what is meant by saying it is arranged for single unit control. It is itself a single power unit like a steam locomotive. The electric switcher is fitted with trolley and contact shoes for over-head or third rail connection, though these are not shown in our illustration. It is equipped with General Electric Company's straight air brakes, operated by one cen-

trifrigal pump, capable of compressing 22 cubic feet of free air per minute. The platform and framing is of 10-in. steel channels and 3-16 floor plates. The cab is of what is called the steeple type and consists of one main cab and two auxiliary cabs. These so-called auxiliary cabs are the two chambers in front of and behind the motorman's box. They look like the tops of slope-back tanks and contain resistance coils and other electrical equipment.

Some of the principal dimensions of the locomotive are as follows:

	Feet.	Inches.
Length over all.....	31	1
Width .....	9	6¼

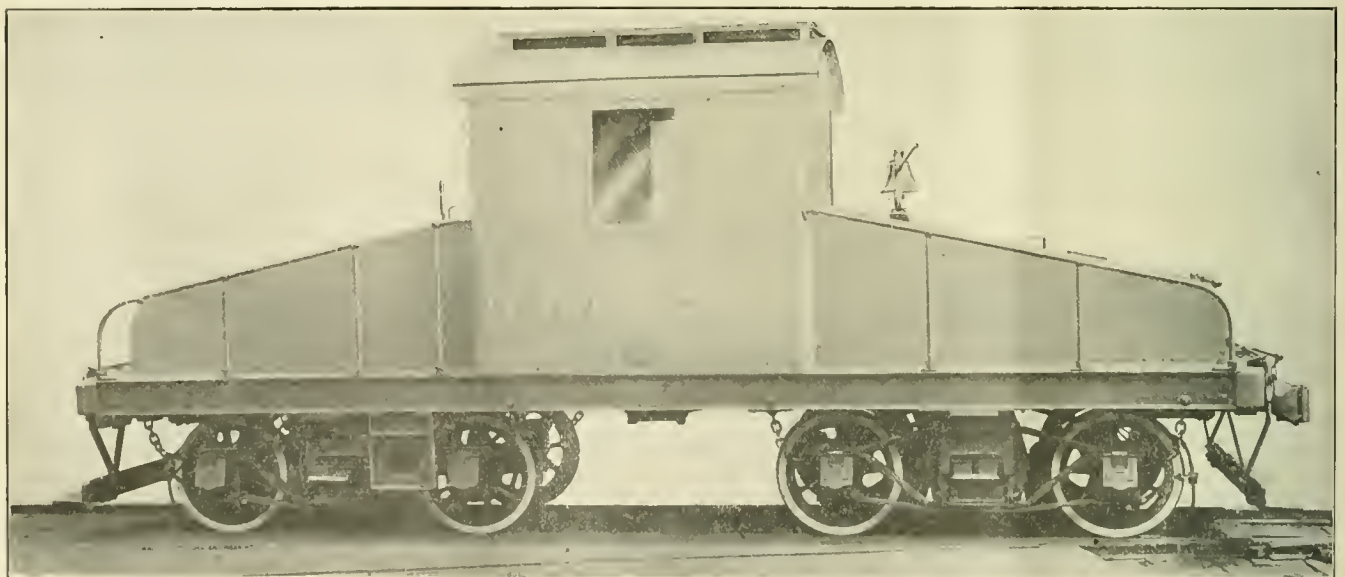

ELECTRIC SWITCHING LOCOMOTIVE FOR THE GENERAL ELECTRIC COMPANY.

tric switching locomotive for the General Electric Company, of Schenectady. The locomotive is designed for operation on a 250-volt circuit and the rated tractive effort is 15,000 lbs. at about 8 miles per hour. The rated tractive effort is practically the force it will exert while operating under normal conditions for one hour at a 75° F. rise in temperature.

The instantaneous draw-bar pull for starting purposes is about 18,800 lbs. This is really the maximum tractive effort, but could not be kept up indefinitely without danger of damage to the motor through over heating. In which case the current becomes short circuited, and the motor burned out. This maximum figure is limited by two things: One is the maximum overload capacity of the motor and the slipping point of the wheels. In practice, the slipping of

equipped with two 175 h. p. General Electric Company's type 68-B direct-current motors. The motors are inside hung, with half the weight carried on the axle and half by nose suspension from the truck frame. The locomotive is arranged for single unit control. This means that if it were coupled in a train which had motor cars in it, these motor cars could not be operated from the electric switcher. In fact, this machine is like a steam locomotive in respect to hauling cars. That is what is meant by saying it is arranged for single unit control. It is itself a single power unit like a steam locomotive.

The electric switcher is fitted with trolley and contact shoes for over-head or third rail connection, though these are not shown in our illustration. It is equipped with General Electric Company's straight air brakes, operated by one cen-

Total wheel base.....	22	—
Driving wheel base.....	6	6
Height over cab.....	12	1¾
Height with trolley down....	13	—
Truck wheels.....	36 ins.	diameter

### Electro-Magnetism.

BY ROGER ATKINSON.

If we allow as an ideal representation of the action of an electric current flowing in a wire or conductor in causing the formation of a magnetic field, called from its action of the N pole of a magnetic needle, a field of rotation, it is not difficult to see what takes place when the wire is formed into a coil or helix. Let A B be the wire carrying a current flowing from A to B, as shown by the straight arrows, then the curved arrow will show the direction of rotation of the magnetic



field namely, in a direction the same as the hands of a clock. Now, if the wire while in this condition be bent round in a circle as in the sketch, the magnetic field in its rotation will go down through the loop when the wire is bent thus, or will come up through the loop if it is coiled in the opposite direction. It will be noticed that it does not make any difference

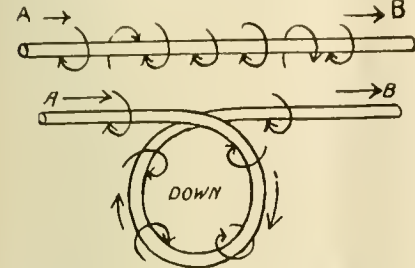

STRAIGHT AND LOOPED WIRES SHOWING FLOW.

in the direction of magnetic flow which way the coils overlay, that is whether the wire is wound right handed or left handed. When the coils are repeated, thus, the helix is commonly called a *solenoid* and the greater part of the rotative magnetic field is carried entirely through the series of loops as shown by the large arrow, so that the "solenoid" if suspended freely will act in the same way as a magnet and the end from which the magnetic field or "magnetic flow" issues will act as the N end of the magnet. See Fig. 1. This coincides with the theory of magnetic flow generally used to illustrate the action of the permanent net, namely that the magnetic flow issues at the N end and enters at the S end.

It should be noticed that the "solenoid" may be coiled backward and forward in several "layers" of coils (see Fig. 2), and the action of the current in causing magnetic flow is the sum of energy of all the coils. Those coils which are on the outside having less effect than the inner ones in proportion to their distance from the centre. The hole through the centre of a solenoid is called the "core." If the

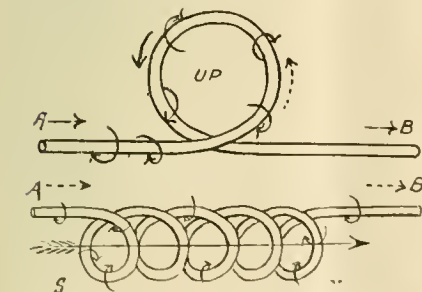

LOOPED AND COILED SHOWING FLOW OF CURRENT.

direction of the current is reversed in any solenoid the polarity is changed, that is the N and S ends are reversed. It was shown that the rotative magnetic field round a single wire decreases in proportion to the increase of distance from the wire. The magnetic field in the core of

a solenoid is *uniform* in strength all over the *cross section*, for the reason that as any point may be taken to weaken by receding from any portion of the wire it is strengthened in an *equal degree* by its approach to the opposite side. When calculations are made the strength of the magnetic field in the core is expressed in certain units called "lines" per square inch or per square centimetre, exactly as steam pressure is expressed per square inch, or wind pressure per square foot. Coils or solenoids are generally wound upon a thin tube of insulating material with circular ends like a bobbin (Fig. 3), and each coil is insulated by having the wire covered with cotton, silk, or other suitable non-conductor so that the current passes through every convolution, and does not get "short circuited," that is, escape by a short path from one coil to another.

As has been already stated, the solenoid has the properties of a magnet, but is not very strong, as the conductivity of the air in the core for magnetism is very low, so low that if compared with iron,

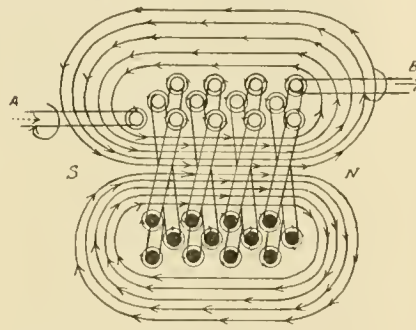

FIG. 2. FLOW THROUGH SEVERAL LAYERS OF WIRE.

the air being taken as 1 or unity, that of iron may be hundreds or even thousands under certain conditions, which may be explained elsewhere. Few substances other than iron (or its alloy, steel) have much more magnetic conductivity than air, and none have less or very little less. This magnetic conductivity is called permeability, and will be so called hereafter. If then we desire to increase the magnetic force of a solenoid we may do so by placing a bar of iron in the hollow tube, the bar being usually a little longer than the insulated bobbin. The resulting magnetic power in the iron bar is not always the same number of times stronger than the magnetic flow in air (or magnetic "flux," as it is called), but depends upon the relative size of the iron core. If the solenoid is a weak one and the iron core is large the "permeability" (or number of times which the iron multiplies the magnetic flow) is low. If the power of the solenoid is increased, the same bar of iron will multiply the magnetic flow more times, and so on until it reaches a maximum of perhaps 1,200 to 1,700 times, depending upon the kind of iron in the core. If the solenoid is still increased in power

the permeability or multiplying effect of the iron begins to fall off, and eventually if the solenoid is made strong enough the multiplying power of the iron disappears altogether. This point is called the point of saturation. If the iron core is pulled partly out when there is no electric current in the wire of the solenoid, then when the current is turned on, the iron

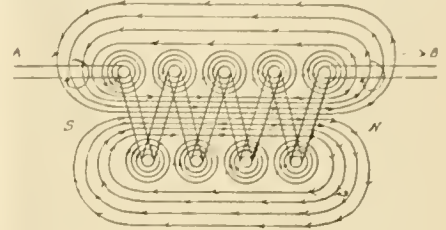

FIG. 1. FLOW OF CURRENT THROUGH SIMPLE COIL.

core will be pulled towards a central position with a force depending upon the power of the solenoid and upon how far the iron is from the centre, and in this way the iron core may be used as a pulling device to produce mechanical movement such as to open or close a switch or valve, etc.

### The Lodestone.

In the olden times, as we may say, magnetism was known to mankind, though it was not in any way associated with electricity. The property of attracting bits of iron was found to be possessed by certain hard black stones and to this curious mineral the name of Lodestone was given. It was found that when a piece of steel was rubbed with the lodestone, the steel became magnetic and like the lodestone, was able to attract light particles of iron, steel, steel nickel, cobalt, etc. Artificially magnetized steel was also able to impart to other pieces of steel a certain amount of the magnetic property when they had been brought in contact with it. The magnetic powers of lodestones were comparatively

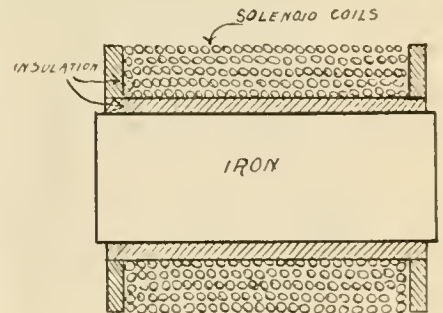

FIG. 3. WINDING OF A SOLENOID.

feeble, and it was what we now call the magnetic oxide of iron or  $Fe_3O_4$ . The word lodestone has now rather a literary or poetic significance rather than a practical meaning, and it is often used to indicate the power of self-contained attraction. The lodestone was first found at Magnesia in Asia Minor, and from the name of this locality we get the words magnet and magnetism.

## Motive Power of the Lehigh Valley Railroad.

From "Development of the Locomotive."

By Angus Sinclair.

### STUPENDOUS UNDERTAKING.

When Hannibal undertook to cross the Alps with a great army, he entered upon an achievement in travel of unparalleled difficulty. If the great Carthaginian general had advisers they doubtless did their best to deter their chief from his purpose, and the lower elements of the army, who had not reached the dignity of being advisers, no doubt sneered at and criticised the enterprise, which they felt certain would end in disaster. Such is the reception given to all uncommon projects.

Early in the year 1852 a group of enterprising men entered upon the work of constructing a railroad through the Alps of America, from Mauch Chunk to Easton, Pa., an undertaking much more formidable than the work of transporting 100,000 soldiers over the Italian Alps. The railroad project was embarked in for the purpose of gathering some of the natural riches of the Lehigh Valley, but the ambition of the promoters received scant sympathy and small financial support. Building railroads through mountain obstacles had not yet become popular. A recent writer recalling the discouragement that depressed this enterprise, says:

### GENESIS OF THE LEHIGH VALLEY RAILROAD.

"The early days of the Lehigh Valley Railroad were days of tribulation. There was lack of encouragement and lack of financial help. Skepticism of the feasibility of the project ruled in Lehigh Valley communities, and both skepticism and ridicule were meted out to its projectors by outside critics. Expressions of good will and wishes for success were not entirely absent, but the helping hand was withheld."

The original preliminary survey of the Delaware, Lehigh, Schuylkill and Susquehanna Railroad, under which name the Lehigh Valley Railroad was incorporated in 1846, was made by Roswell B. Mason for a number of citizens living in New Jersey. There was a vague idea among them that the railroad would be used to convey coal and merchandise to the four rivers named in the charter for transport to the ocean, thence to the world of commerce. When, however, the incorporators came to investigate the character of the country to be traversed by their railroad, they lost courage, and the scheme was abandoned and lay dormant for several years.

In 1852 the charter was secured by Asa Packer, who had an unwavering faith in the resources of the Lehigh Valley, with the inflexible determination to

utilize them. His foresight and faith in the enterprise in the face of difficulties that would have appalled most men, were backed by splendid courage and a tireless energy, which won victory for him and the faithful band of brave spirits who co-operated with him. The name of the road was changed by act of legislature in 1853 to the Lehigh Valley Railroad.

Asa Packer and the Chief Engineer Robert H. Sayre were the active powers of the road. Upon their shoulders rested the responsibility and work. The two represented the functions of all the departments that make up a railway organization of to-day; the one, the executive and financing departments, the other, the construction and operating departments. The little, as well as the big things, demanded their personal attention, exacting of them eternal vigilance.

### MAUCH CHUNK INCLINED PLANE.

New England is proud to claim the honor of having had within its borders the first railroad in America to carry wheeled vehicles. Pennsylvania comes next with its famous gravity railroad, opened in 1827, from the Lehigh River to Mount Pisgah, a peak 1,500 feet above sea level, in the heart of a rich anthracite region. This inclined plane railroad was built for the transportation of coal to the river. It is now operated as a scenic railroad and draws multitudes of visitors every summer.

When we come to regard its oldest member as an integral part of a consolidated railroad system we have to credit the short, tortuous, inclined plane of Mauch Chunk as being the most ancient part of the Lehigh Valley Railroad.

### BEAVER MEADOW RAILROAD.

Another possession of ancient origin was the Beaver Meadow Railroad, which was projected in 1830 and put in operation in 1836. That was a famous little railroad in its day. Its purpose was to transport anthracite coal from the mines near Beaver Meadow in the Mauch Chunk region for shipment on the Lehigh Canal. Its location was through a remarkably rugged mountain district, where it wound by steep hillsides, over torrential streams, through swamps and forests by a route that involved the greatest difficulties of construction then encountered in railroad building. Although there was no direct connection between the undertakings the construction of the Beaver Meadow Railroad was a fitting introduction to the building of the Lehigh Valley Railroad.

The Beaver Meadow Railroad was as famous for different locomotives it possessed as was the Lehigh Valley for the novel forms its people produced in developing locomotives adapted to hauling heavy loads over steep grades.

The first locomotive that belonged to the Beaver Meadow Railroad was called the Samuel D. Ingham, after president of the company, and was notable among the railroad motive power of that time. It was built by Garrett & Eastwick, of Philadelphia, was of the eight-wheel type, had a peculiar valve motion designed by Andrew M. Eastwick, reversing being done by a block sliding on the valve seats, and it was the first locomotive in Pennsylvania to be provided with a cab for sheltering the engine crew.

### EXTENSION AND CONSOLIDATION.

The first section of the Lehigh Valley Railroad was no sooner opened than the company was flooded with business far beyond the most sanguine expectations of the promoters. At the head of the company were men of a pushing, enterprising character, who perceived the golden opportunities that their inroad into virgin territory had brought forth and they proceeded to make the best of them. A policy of extension and consolidation was adopted, and the management proceeded gradually to the absorbing of fragmentary roads calculated to be worked up into a great trunk line.

In 1864 the Lehigh Valley Railroad Company absorbed the Beaver Meadow Railroad, an important move, for it took away a competitor and seemed a valuable feeder from the richest anthracite regions. A few months later a consolidation was effected with the Penn Haven and White Haven Railroad. In 1866 another consolidation was effected, and the Lehigh and Mahonoy Railroad became part of the Lehigh Valley Railroad. This consolidation gave the name to the type of eight-wheel connected and leading pony truck locomotive designed by Alexander Mitchell and built that year. At the same time was purchased the North Branch Canal, extending from Wilkes-Barre to New York State line, a distance of 105 miles, with the privilege of laying a track the whole distance. Other consolidations and absorptions followed, and now the Lehigh Valley Railroad Company operates about 1,400 miles of track, with about 800 locomotives and 40,000 cars.

### GRICE AND LONG LOCOMOTIVES.

The principal freight handled by the Lehigh Valley Railroad Company has always been coal and other minerals. The mechanical officials from the first displayed a leaning toward heavy motive power that would handle economically heavy freight over the steep grades. Before discussing particulars of their progress in this line, I wish to allude to a peculiar type of mine locomotives used on some of the branches. Fig. 1 illustrates one of these Grice and Long locomotives, which was at work at Packer No. 4 Colliery as late as 1901.

This was a four-wheeled locomotive,

with built up frame. The boiler, which is of the internally fired, return tubular type, is placed over the front pair of wheels. The cylinders, which are placed nearly vertical over rear axle, are in the

Walschaerts valve motion, which was used all the time the engines were kept in service, probably twenty years. The engines were bought in Cincinnati at Sheriff's sale, and were taken by river and

satisfactory performance of these engines a record of tonnage hauled is taken from the president's report for the year ending January, 1858: "During the six months from April to September, inclusive, the engine 'Catasauqua' ran 11,236 miles, and hauled 11,231 loaded and 11,246 empty cars of 5 tons each. In the month of July the engine 'Lehigh' made 26 round trips, with an average load of 535 tons of coal per day." It is interesting to compare the performance of these engines with the present rating of freight engines over this same division.

The "Catasauqua" and the "Lehigh" were six-wheel connected drivers with a four-wheel leading truck, and weight about 46,000 lbs.

NORRIS AND MASON ENGINES.

In 1856 the E. A. Packer was purchased from Wm. Mason, of Taunton, Mass., and that builder continued to supply locomotives to the road as long as he lived. This engine was used in passenger service and was equipped with the Boardman boiler. The peculiar construction of the Boardman boiler required the use of eccentrics on a return crank attached to the main pin. This engine was also equipped with a "Low Moor Iron" firebox, which was in constant use for eleven years without renewal. This was considered at that time the best obtainable material for fireboxes.

From 1855-66 the majority of the engines in use were either from Norris or Mason. There were some Baldwins, and a very few Brandt engines, built at Lancaster, Pa. James A. Norris was proprietor of the Lancaster Locomotive Works and John Brandt superintendent.

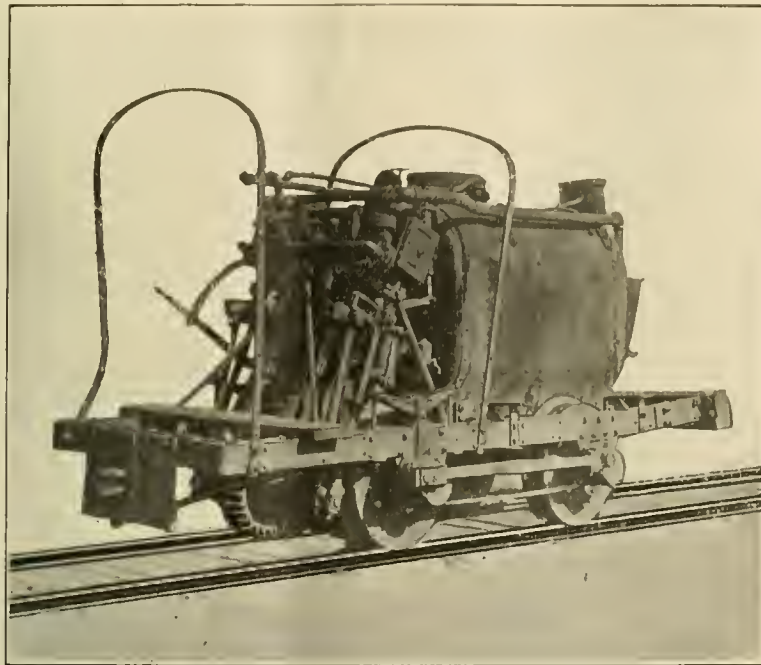

FIG. 1. GRICE & LONG LOCOMOTIVE.

rear of the boiler. The connecting rods drive a cranked shaft on which a gear is placed. This gear in turn drives a pinion on rear axle. The wheels are inside the frame, and axles are cranked for parallel rods. Only the rear pair of wheels are equipped with springs. Shifting or so-called Stephenson link motion was used, and the lost motion in parallel rods was taken up on one end by taper key, on the other by a set bolt lock nut.

In spite of very persistent search, I have been unable to find out who designed these extraordinary locomotives, but it certainly was a man with some engineering ideas, the leanings being towards marine practice. They were evidently patterned somewhat after the Baltimore and Ohio Grasshopper engines, being made so short and compact that they would go round any curve, but the boiler was of a decidedly better form and the engine was likely to do its work on less steam, while it was very convenient for repairing.

EARLY FOUR CYLINDER ENGINES.

Among curious locomotives possessed by the Lehigh Valley were two called the "Defiance" and the "Champion," built by the Niles Locomotive Works of Cincinnati, and purchased by the Beaver Meadow Railroad Company in 1857. They were designed for service on an inclined plane and had cog gearing for working on a rack rail. There were four cylinders, two inside and two outside, had four pairs of driving wheels connected outside, but no truck. They were equipped with the

canal to Penn Haven, thence to Weatherly by rail.

This information came to me from Alexander Mitchell, of Wilkes-Barre, Pa., who was long an official of the Lehigh Valley Railroad, and put a permanent imprint upon the motive power of the world.

The first passenger engines belonging

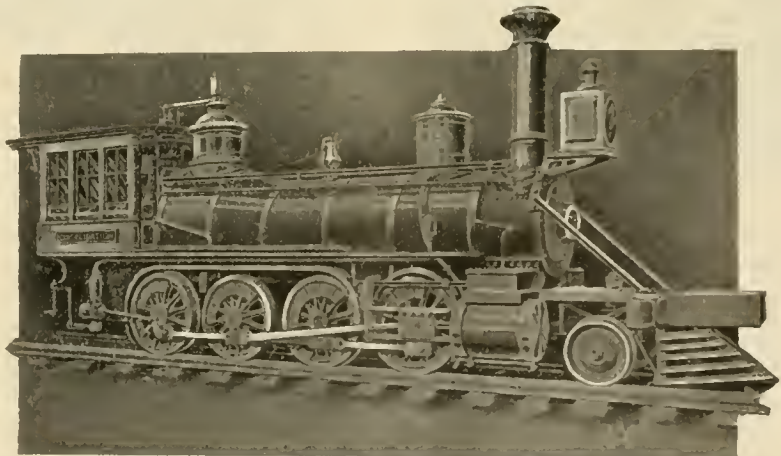

FIG. 2. ALEXANDER MITCHELL'S "CONSOLIDATION."

to the Lehigh Valley from 1855-1859 were wood burners; all freight engines burned coal. Wood burning locomotives were in use on that system as late as 1869, a curious practice to exist on a strictly coal carrying railroad.

In 1856 three engines with Phlegers patent boilers and Norris cut-off valve motion were purchased of Norris & Son, of Philadelphia. As an evidence of the

The Mason engines were favorites among the enginemen. They had the main wheel forward, which made them flexible on curves and free from nosing. They were very good steamers and powerful engines for their weight, the draw bar between engine and tender being offset so that in starting a heavy train part of the weight of the tender was thrown on the drivers.

The Norris engines, and also the Brandt engines, were equipped with the link-cut-off, which had to be thrown in and out while the engine was in motion.

#### READY TO ADOPT IMPROVEMENTS.

All throughout the history of the Lehigh Valley Railroad it may be noticed

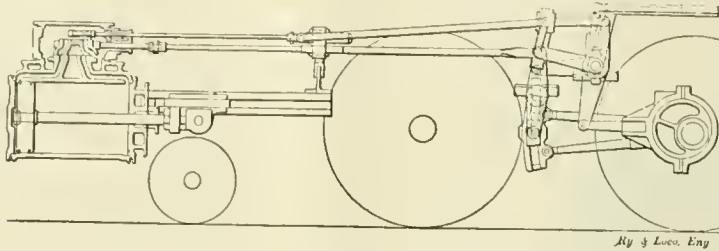

FIG. 3. CLARK'S INDEPENDENT CUT-OFF MOTION.

that the men in charge of the rolling stock were always ready to adopt improvements and this company was among the first to reap the saving from a variety of inventions whose purpose was to reduce the cost of fuel and repairs, to prevent accidents, and to increase the comfort of train men.

By the time that the year 1865 opened the company possessed a rather heterogeneous supply of locomotives, the aim evidently being to try all sorts to find out which kind produced the best results. R. Norris, Baldwin and Mason had been the principal builders, but there were engines from Brandt, of Lancaster, Pa.; Trenton Locomotive Works; Niles Locomotive Works, Cincinnati, Ohio; New Jersey Locomotive Works, Paterson, N. J.; Danforth & Cooke, Paterson, N. J.; A. Pardee & Co., and J. A. Norris.

#### MASTER MECHANICS INVITED TO DESIGN LOCOMOTIVES.

About this time the management put upon the master mechanics the responsibility of producing locomotives especially adapted for the peculiarities of the system. The first result of this movement was the designing of the consolidation form of engine (Fig 2) by Alexander Mitchell, master mechanic of the Mahanoy



FIG. 4. MASON'S DOUBLE-HEADED "JANUS."

Division. That was in 1866. The engine was built by the Baldwin Locomotive Works and was a striking success from the first. Within a very few years it became one of the most popular locomotives all over the world.

#### COMPANY BUILDS THEIR OWN LOCOMOTIVES.

In 1867 the Lehigh Valley Railroad began the practice of building their own locomotives as far as their shop facilities would permit. Engines were built at Delano, Weatherly, Wilkesbarre, Sayre, and at the So. Easton shop.

This practice adopted by the company to build their own engines as far as possible furnished abundant opportunity to develop individual ability, a practice that had decided disadvantages. Every division master mechanic became a law unto himself concerning what form of locomotive he should build. The theory was

other, the motive of difference sometimes being merely dread of imitation.

An undeniable result of the system of making every master mechanic independent of the others was the accumulation of an assortment of patterns such as no other railroad company ever possessed.

There was quite a variety of odd locomotives built by the Lehigh Valley people—some of them marking progress, others marking things and practices that ought to be avoided.

#### CLARK'S INDEPENDENT CUT-OFF LOCOMOTIVES.

Prominent among those oddities were certain locomotives built by David Clark, with a link motion and independent cut-off valve. This gear had six eccentrics, straps and rods, four rock shafts, two reverse levers and rods, two additional valves, valve seats, valve stems and stuffing boxes. The motion is illustrated in Fig. 3. The engines produced what were probably the finest indicator diagrams ever made by a locomotive, but it did not effect any saving of fuel over a common link motion engine of the same class.

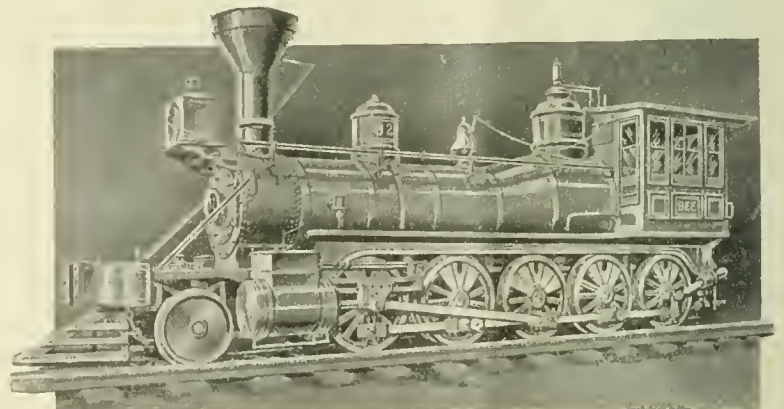

FIG. 5. "BEE" LOCOMOTIVE, WITH TEN DRIVING WHEELS.

that each master mechanic was the best judge of the kind of engine best adopted for the physical characteristics of that part of the line where he had charge.

The result was great rivalry among the different master mechanics with train men

In 1871 the company purchased Mason's "Janus" (Fig. 4), a double-headed engine of the Fairlie type. It did good work as a pusher, and was popular with the engineers, but it never was duplicated.

Alexander Mitchell tried to advance on the consolidation with two engines called the "Ant" and the "Bee" (Fig. 5), which had five pairs of drivers connected and a pony truck in front. The engines gave some trouble on curves, so the back pair of drivers were taken out and a pair of small carrying wheels substituted, making the first of the 2-8-2 or Mikado type. Two engines were built by the Norris Locomotive Works, Lancaster, Pa., in 1867. Quite a number of this kind of engine is now used in mountain service.

#### SEARCHING FOR THE FITTEST.

Master Mechanic Philip Hoffecker attempted to improve on Mitchell's 2-10-0 engines by applying a four-wheel truck

(Continued on page 36.)

active partisans ready to abuse or praise the engines, and frequently to put at a disadvantage those they disliked. There were Hoffecker engines, Campbell engines, Michell engines, Clark engines, and Kinsey engines, all differing from each

# Of Personal Interest

Mr. William W. Finley has been elected president of the Southern Railway, the vacancy having been caused by the tragic death of Samuel Spencer. Mr. Finley was born in Mississippi in 1853 and began his railroad work as stenographer on the New Orleans, Jackson & Great Northern, which road now forms part of the Illinois Central. He subsequently was appointed assistant general freight agent on the Texas & Pacific and in 1886 he became general freight agent. In 1888 he took a similar position on the roads comprising what was called the "Panhandle Route." In 1889 he was made chairman of the Missouri Traffic Association and the following year he became chairman of the Western Passenger association. His next appointment was that of general traffic manager of the Great Northern and three years later he went to the Southern as



W. W. FINLEY.

third vice president. For a short interval he became again connected with the Great Northern as second vice-president, but returned in a similar capacity to the Southern, of which road he is now the executive head. Mr. Finley has thus had an extensive railroad experience, not only by reason of his connection with several important lines and associations, but because his services have been secured by roads which are necessarily operated under widely different conditions, and the new president of the Southern, now in the very prime of life, is well fitted to discharge the onerous duties and cope with the responsibilities which such a position necessarily involves.

Mr. Frank Johnson has been appointed general foreman of the Southern Railway shops at Knoxville, Tenn., vice Mr. T. H. Williams promoted.

Mr. G. M. Basford, who has been in charge of the Publicity Department of the American Locomotive Company, has been appointed assistant to the president of the company.

Mr. G. Roy Bullen has been appointed general agent for the freight and passenger departments of the Chicago Great Western Railway, with headquarters in Winnipeg, Manitoba, vice Mr. D. Morrison, resigned.

Mr. W. J. McKee has been appointed general superintendent of the Central District of the Missouri Pacific Railway, with office at Coffeyville, Kas., vice Mr. A. DeBernardi, transferred.

Mr. A. DeBernardi has been appointed general superintendent of the Southern District of the Missouri Pacific Railway, with office at Little Rock, Ark., vice Mr. H. Baker, resigned.

Mr. J. E. Maloney has been appointed traveling fireman for the Western Division of the New York Central Railroad.

Mr. S. L. Girsley has been appointed traveling fireman for the Western Division of the New York Central Railroad.

Mr. William Schlafge, master mechanic of the New York Division of the Erie Railroad, has been appointed master car builder of that road, with headquarters at Meadville, Pa., vice Mr. R. W. Burnett, resigned.

Mr. J. J. Dewey, master mechanic of the Cincinnati Division of the Erie Railroad, has been transferred to the New York Division of the same road, with headquarters at Jersey City, N. J., vice Mr. William Schlafge, promoted.

Mr. C. James, master mechanic of the Rochester Division of the Erie Railroad, has been transferred to the Cincinnati Division, with headquarters at Galion, Ohio, vice Mr. J. J. Dewey, transferred.

Mr. D. Van Riper, general foreman of the Meadville Shops of the Erie Railroad, has been appointed master mechanic of the Rochester Division at Avon, N. Y., vice Mr. James, transferred.

Mr. G. A. Moriarty, general foreman of the Port Jervis Shops of the Erie Railroad, has been appointed master mechanic of the Delaware Division of the same road, with headquarters at Port Jervis, N. Y.

Mr. J. H. Green has been appointed master mechanic of the Norfolk & Southern Railroad, with headquarters at Newbern, N. C.

Mr. D. Anderson has been appointed master mechanic of the Chicago Union Transfer Railway, with office at Clearing, Ill., vice Mr. E. Owen, resigned.

Mr. F. W. Williams has been appointed division master mechanic of the Chicago, Rock Island & Pacific Railway at Chicka-

sha, I. T., vice Mr. James McDonough, resigned.

The promotion of Mr. M. J. Drury to the position of mechanical superintendent of the western grand division of the Atchison, Topeka & Santa Fe was mentioned in our columns last month and we reproduce his photograph in this issue. He entered the service of the Santa Fe Railway Company as machinist at Topeka, Kans., in February, 1889, and after a few months' service was appointed gang foreman, remaining in that position until May, 1893, when he was appointed general foreman at La Junta, Colo. Later on he was transferred to a similar position on the Oklahoma division at Arkansas City, Kans., in October, 1895, and was made division foreman of that division in 1900. He was subsequently appointed master mechanic of the Albuquerque division at



M. J. DRURY.

Windslow, Ariz., in October, 1902; appointed master mechanic of the New Mexico and Rio Grande divisions, with headquarters at Raton, New Mexico, May, 1906, and appointed mechanical superintendent of the Western Grand Division, with headquarters at La Junta, Colo., November 1, 1906.

Mr. T. H. Williams, formerly general foreman of the Southern Railway shops at Knoxville, Tenn., has been appointed division foreman on the same road, having jurisdiction over all the company's shops on the Knoxville division.

Mr. W. E. Neal has been appointed roundhouse foreman of the Chicago, Lake Shore & Eastern Railway, at Rossville, Ill.

Mr. George Spencer, superintendent of the Toronto to Smith's Falls Division of the Canadian Pacific Railroad, has been

moved to the North Bay District, vice Mr. J. R. Nelson, transferred.

Mr. J. R. Nelson, superintendent of the North Bay district on the Canadian Pacific Railway, has been transferred to Toronto. He will have charge of the line from Toronto to Smith's Falls, vice Mr. George Spencer, transferred.

Mr. Edward W. Hodgkins, vice-president of Adreon & Company, is in charge of the St. Louis office, which is now at No. 208 in the Western Union building in that city. The company handles a number of railroad specialties.

Mr. F. M. Steele, for several years an engineer on the Western Division of the New York Central & Hudson River Railroad, has been promoted to the position of road foreman of engines, vice Mr. W. C. Crandall, promoted. Mr. Steele is a young man of good character and judgment and we predict for him every success in his advanced position. Mr. Steele's office headquarters are in Rochester, N. Y.

Mr. R. Anthony, locomotive foreman on the Canadian Pacific Railway, has been transferred from Revelstoke, B. C., to Cranbrook, B. C.

Mr. W. H. Hudson, general master mechanic of the Western Division of the Southern Railroad, with offices at Knoxville, Tenn., has resigned to go into other business.

Mr. J. S. Lemly has been appointed assistant trainmaster on the Wheeling Division of the Baltimore & Ohio Railroad, at McMeechen, W. Va.

Mr. E. A. Lacey has been appointed road foreman of engines of the Buffalo & Susquehanna Railroad, with headquarters at Galeton, Pa.

Mr. W. K. Larr has been appointed road foreman of engines and trainmaster of the Peoria Division of the Vandalia Line.

Mr. J. W. Dodd has been appointed night foreman of the Canadian Pacific Railway, at North Bay, Ont.

Mr. J. H. Mathers has been appointed night foreman of the Canadian Pacific Railway at Chapleau, Ont.

Mr. H. Jacob has been appointed night foreman of the Canadian Pacific Railway at Schrieber, Ont.

Mr. A. H. Eager, heretofore general foreman of the Canadian Pacific Railway Shops at Cranbrook, B. C., has been transferred to a similar position at Calgary, Alta., vice Mr. W. Byrd, transferred.

Mr. J. G. Norquay, heretofore road foreman of locomotives, District No. 2, Western Division, Cranbrook, B. C., has been transferred to a similar position in District No. 1, Western Division, of the Canadian Pacific Railway, vice Mr. R. D. Smith, promoted.

Mr. A. Stewart has been appointed general superintendent motive power and equipment of the Southern Railway, with headquarters at Washington, D. C. The office of mechanical superintendent has been abolished.

### The Late Samuel Spencer.

President Samuel Spencer, of the Southern Railway, lost his life in a train collision near Lynchburg, Va., on November 29. We have never met a man of Mr. Spencer's high standing likely to be more sincerely regretted by a host of friends and admirers. RAILWAY AND LOCOMOTIVE ENGINEERING has lost one of its best friends and its officials mourn the personal bereavement with sincere regret.

Mr. Spencer had been the finest type of American railway general managers and may be regarded as an excellent representation of the railroad man who builds sound practical training upon the foundation of a first class education. Samuel Spencer was born at Columbus, Ga., in 1847, and having enjoyed a university education, entered railroad service through the engineering department of the Savannah & Memphis Railroad. He came to



SAMUEL SPENCER.

realize early that the operating department had the road through which railroad men climb the ladder to the top. We find him when twenty-five years old working as a clerk to the superintendent of the New Jersey Southern Railroad. His intelligent diligence pushed him along rapidly through the grades of supervisor of trains of the Baltimore & Ohio, general superintendent of the Long Island Railroad, general manager of a section of the Baltimore & Ohio, and ultimately president of the Southern Railway. He was a kindly, genial man, who drew others with the confidence that they were dealing with a superior who was ever ready to temper justice with mercy. It is a pity that such a good man was taken and so many left we well could spare.

Mr. George A. Ellwanour has been appointed foreman of car inspectors on the West Penn Division of the Pennsylvania with office in Allegheny, Pa.

Mr. C. A. Livingston has been appointed locomotive foreman of the Grand Trunk Railway, at Fort Erie, Ont., vice Mr. I. Jefferis, resigned.

Mr. J. Cardell, formerly master mechanic of the Canadian Pacific Railway at Calgary, Alta., has been assigned special duties by the assistant superintendent of motive power, Western lines of the C. P. R. Mr. Cardell's headquarters are at Calgary, Alta.

Mr. W. G. Edmonson, engineer of tests, has been appointed mechanical engineer of the Philadelphia & Reading Railroad, vice Mr. F. F. Gaines, resigned.

Mr. Howard Stillman, heretofore engineer of tests, has been appointed mechanical engineer of the Southern Pacific Railroad, vice Mr. F. W. Mahl, resigned.

Mr. F. F. Gaines, formerly mechanical engineer of the Philadelphia & Reading, has been appointed superintendent of motive power of the Central Railroad of Georgia, vice Mr. W. E. Chester, resigned. The position of general master mechanic has been abolished on that road. Mr. Gaines began as an apprentice on the Erie & Yoming for about a year, after which he went to the Lehigh Valley and worked as a draughtsman for about five years. He then became engineer of tests. He subsequently held the position of chief draughtsman, and was made mechanical engineer, which position he held for about six years, after which he was master mechanic of the Wyoming division for about two years. He was with the Philadelphia & Reading for about two years before his present appointment on the Central Railroad of Georgia.

Mr. C. W. Burke, heretofore machine shop foreman in the Baltimore & Ohio shops at Garrett, Ind., has been promoted to be general foreman of the same shops.

Mr. A. Tribby has been appointed fuel inspector on the Baltimore & Ohio, vice Mr. J. S. Coniff, promoted.

Mr. J. S. Coniff, formerly fuel inspector on the Baltimore & Ohio, has been promoted to the position of road foreman of engines on the east end of the Cumberland Division, vice Mr. W. B. Blackwell, resigned.

Mr. W. S. Murrain, master mechanic on the Southern Railroad at Spencer, N. C., has been transferred to Knoxville in a similar capacity on the same road, vice Mr. W. H. Hudson, resigned.

Mr. J. R. Shanks has been appointed master mechanic of the East Broad Top Railroad, with headquarters at Orbisonia, Pa., vice Edgar Shellabarger, deceased.

Mr. Geo. W. Smith has been appointed traveling fuel inspector and general traveling fireman of the Chicago, Milwaukee & St. Paul, with office at St. Paul, Minn.

Mr. J. E. Cameron, formerly master mechanic of the Atlanta, Birmingham & Atlantic shops at Waycross, has been transferred as master mechanic of the same company's shops at Fitzgerald, Ga.

Mr. W. W. Finley, president of the Southern Railway, has been elected president of the Georgia Southern & Florida Railway, as well as a member of the board of directors.

Mr. Frank Walters has been made general manager of the Chicago & Northwestern's lines west of the Missouri river. He has succeeded G. F. W. Bidwell, who resigned on account of ill health.

Colonel Frederick P. Fox, formerly division passenger agent of the Delaware, Lackawanna & Western at Buffalo, has been appointed industrial agent of the Lackawanna, with office in New York, vice Mr. W. P. Colton, resigned. Before entering railroad service he was a well known newspaper writer, and thus received a training and experience, as well as a wide acquaintanceship that specially fits him for the new duties he has assumed

quin Division of the same road, with headquarters at Bakersfield, vice Mr. D. P. Kellogg, transferred.

Mr. William Merry, general foreman of the Southern Pacific Shops at Tucson, has been transferred as general foreman of the Los Angeles Shops of the Southern Pacific Company, vice Mr. J. Shellaberger, promoted.

Mr. J. W. Small, heretofore master mechanic on the Southern Pacific Company at Los Angeles, has been appointed superintendent of motive power of the Randol Lines in Arizona and Mexico.

Mr. J. J. Scully, heretofore superintendent of District No. 3, Central Division, of the Canadian Pacific Railway, at Brandon, Man., has been appointed superintendent of District No. 1, Central Division of the Canadian Pacific Railway, at Kenora, Ont., vice Mr. O. O. Winter, transferred.

wishes for his success of all those over whom he will have jurisdiction, and the New York Central System is to be congratulated that it possesses men of Mr. Crandall's character and judgment, to promote to the higher positions. Mr. Crandall's office headquarters are at Syracuse, N. Y.

#### Mexican Central Oil Burner.

The American Locomotive Company's shops at Paterson, N. J., formerly called the Cooke Locomotive Works, have recently turned out some consolidation engines for the Mexican Central Railroad. These 2-8-0 freighters burn crude oil and are altogether very powerful machines, and with the large tapering smoke stack, steel cab, and large windows, present what may be called a very business-like appearance.



CONSOLIDATION OIL BURNER ON THE MEXICAN CENTRAL.

Ben Johnson, Supt. of Mach.

American Locomotive Co., Builders.

in their relationship to newspapers and other publications.

Mr. J. T. Harahan has been elected president of the Illinois Central Railroad, vice Mr. Stuyvesant Fish, resigned. Mr. Harahan has steadily risen in railway service, and has been officially connected with the Louisville & Nashville, and the Lake Shore & Michigan Southern Railway. For sixteen years he has been an officer of the Illinois Central and has been promoted in that service from one position to another until at last he has reached the highest executive position in the gift of the board of directors.

Mr. D. P. Kellogg, master mechanic of the San Joaquin Division of the Southern Pacific Company at Bakersfield, has been transferred to the Los Angeles Division, with headquarters at Los Angeles, Cal., vice Mr. J. W. Small, resigned.

Mr. J. Shellaberger, heretofore general foreman of the Los Angeles Shops of the Southern Pacific Company, has been appointed master mechanic of the San Joa-

quin Division of the same road, with headquarters at Bakersfield, vice Mr. D. P. Kellogg, transferred.

Mr. O. O. Winter, heretofore superintendent of District No. 1, Central Division of the Canadian Pacific Railway, at Kenora, Ont., has been appointed superintendent of District No. 3 of the Canadian Pacific Railway, at Brandon, Man., vice Mr. J. J. Scully, transferred.

Mr. Wm. J. Crandall, for the past five years road foreman of engines on the Western Division of the New York Central & Hudson River Railroad, has been appointed master mechanic with jurisdiction over that portion of the division between Rochester and Syracuse. Mr. Crandall has been in the service of the New York Central for twenty years, commencing in the capacity of a locomotive fireman, and foreman of engines to his present position. During the whole of Mr. Crandall's term of service he has discharged the duties of his position with entire satisfaction to the officials of the company he served, and at the same time he has won the respect and esteem of his fellow employees. In his present position he has the best

The cylinders are simple, being 21 x 26 ins., with piston valves. The driving wheels are 55 ins. in diameter and with a boiler pressure of 200 lbs. to the square inch, the calculated tractive effort is 35,440 lbs., and with 180,000 lbs. on the drivers the ratio of tractive effort to adhesive weight is as 1 to 5, very nearly. This makes the engine one with little tendency to slip. The valves are inside admission, actuated by the Stephenson link motion. They have a travel of 5½ ins., lead 1-32 diameter. The H.P. pistons drive on the crank axle of the leading pair with comparatively short connecting rods, and the pistons of the L.P. cylinders, which are outside, drive on the centre pair.

The ratio of the cylinder volumes is 1 to 2.82. Apart from the difference in strokes, the cylinders are similar to those used on previous balanced compound locomotives built by the Baldwin Locomotive Works. All four guides are braced by one guide bearer. The crank axle is of the Z form, forged in one piece. The

valves are of the piston type and are actuated by Stephenson Link motion of the indirect kind. The engine frames are of cast steel of the usual bar type. All the wheels are flanged. The driving wheel base is 13 ft. 6 ins. The total engine wheel base is 26 ft. 9 ins. and with tender the wheel base is in all 55 ft. 6 ins. The weight on the drivers is estimated at 99,000 lbs., while the front truck carries 47,000 lbs., making a total of 146,000 lbs. When the weight of the tender is added the whole becomes 262,000 lbs.

A screw reverse mechanism is used. The special equipment includes Friedmann injectors, English Westinghouse air brakes and "Italian type" Coale muffled safety valves. Whitworth standard threads are used for all bolts and nuts. The screw couplers, drawhooks and spring buffers conform to designs furnished by the railroad company. All the driving-wheel centres are of cast steel, with tires held by retaining rings. The engine truck and tender wheels are of solid rolled steel. The rims are thick enough to enable tires to be shrunk on when the diameters have become sufficiently reduced by wear. The engines are fitted with steam heat equipment.

The boiler is of the straight top type, having narrow fire box. Five locomotives have fire boxes made of copper, while steel is used in the remainder. The fire door opening is formed with a cast

ft. in all, made up of 150 in the fire box and 2,018 in the flues. These are 250 in number and 15 ft. 6 ins. long. The grate area is 33¼ sq. ft.

phasized by the absence of a headlight, pilot, bell and cab windows. Some of the principal dimensions are appended for reference:

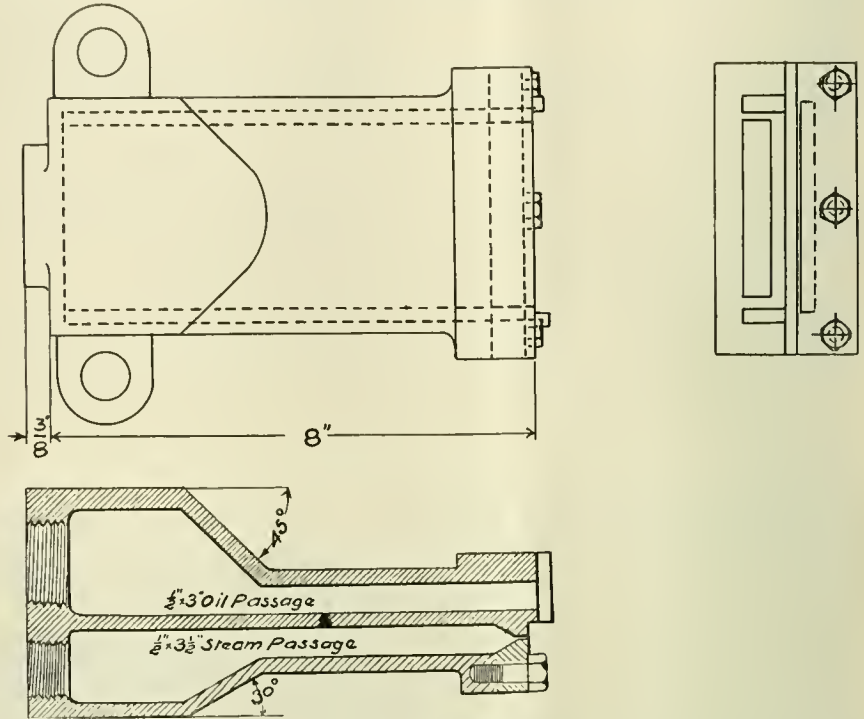

CONSTRUCTION OF THE BURNER, SHOWING OIL AND STEAM JET OPENING.

The tenders are of the usual type, having U-shaped tanks and frames built of 10-in. steel channels. The water capacity

- Gauge, 4 ft. 9 ins.
- Boiler—Diameter, 60 ins.; thickness of sheets, 5/8 in.; working pressure, 200 lbs.; fuel, coal and briquettes; staving, radial.
- Firebox—Length, 114 3/16 ins.; width, 42 3/8 ins.; depth, front 69 1/4 ins., back 57 1/4 ins.; thickness of sheets, sides 5/16 in., back 5/16 in., crown 3/8 in., tube 1/2 in.; water space, front 4 ins., sides 3 ins., back 3 ins.
- Driving Wheels—Diameter outside, 72.83 ins.; journals, main, 9x10 ins., others 8 1/2 x 9 1/4 ins.
- Engine Truck Wheels—Front, diameter, 33 ins.; journals, 5 1/2 x 10 ins.
- Tender—Journals, 5x9 ins.
- Service—Passenger.

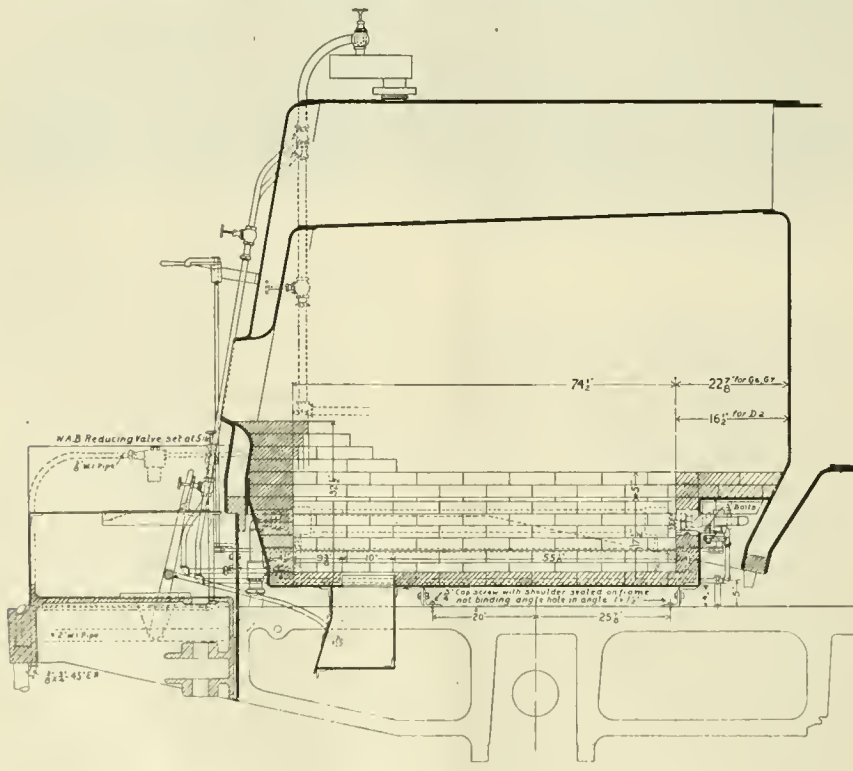

FIREBOX OF MEXICAN CENTRAL OIL BURNER.

steel ring, to which both the inside and outside sheets are riveted. The grates are of the usual rocking type, with drop plates in front. The heating surface is 2,168 sq.

is 5,280 U. S. gallons and the tank carries 6 tons of coal. The engines, though American in many details, nevertheless have a foreign appearance, which is em-

Motive Power on the Lehigh Valley. (Continued from page 32.)

with all the wheels in front of the cylinders. Some of that class of engines are still in service, but they display no superiority over the consolidation engine Rogers people built some Moguls with a four-wheel truck in front of the cylinders, but they never achieved popularity. Hofecker also built 4-8-0 engines afterwards, known as twelve-wheelers (Fig. 6).

STRONG'S DUPLEX.

In the search for a passenger locomotive which could make time over mountain grades, and also haul a heavy train, the famous "Duplex" No. 444, was developed. This engine was built at Wilkesbarre in 1886. It was the first engine equipped with the Strong twin fireboxes for burning anthracite coal. The boiler was 33 ft. long, and was composed of an outer shell in combination with a firebox of two Fox corrugated flues side by side, joining into a combustion chamber. Although the Fox corrugated flue was found very frequently in marine practice, and had been to a limited ex-



tent adapted to locomotives in Germany. The total length of firebox and combustion chamber was 16 ft. 4½ inches. The smallest diameter of flue was 38¼ inches. The length of firebox was 8 ft. 9 ins.

The engine was a failure and was a good illustration of what an amateur will do when he undertakes to design a locomotive.

CAMPBELL'S AUDENRIED.

Another engine with a modification in the link motion was built at Hazleton in 1886. This was an 8-wheel engine, the "Audenried," later changed to "John Campbell," intended for passenger service, was a sister engine to that with the independent cut-off built by David Clark, and had his cut-off valve placed above the slide valve. By means of this valve the cut-off could be varied. When it was not in use, the cut-off valve trav-

Why Elliptical.

In a certain technical college, when the question, "Why are boiler manholes made elliptical, and not circular?" was put to

with a circular manhole.—The Boiler Maker.

In a town in Illinois a traveling the-

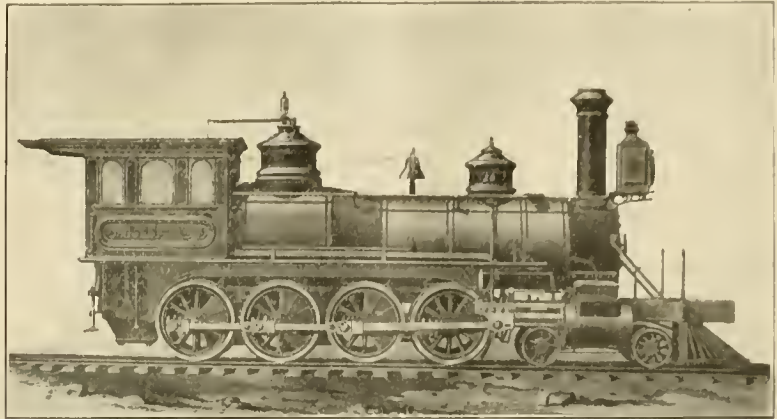

FIG. 6. HOFFRICKER'S 4-8-0 ENGINE.



ON THE LEHIGH VALLEY.

eled the same path as the main slide valve. This cut-off valve rested on top of the main valve, which had steam passages through it, and was operated by an extra eccentric placed on each side of the engine. The motion was transferred to the valve through the medium of a radius bar and slide block. This slide block on radius bar was connected to a lever in the cab by means of a lift shaft and reach rod. Here by means of a notched quadrant, the point of cut-off could be changed at will.

The engine, like Clark's, was celebrated for the beautiful indicator diagrams it produced, but it did not pull any more cars or burn less fuel than the other engines, so the independent cut-off with its extra attachments was allowed to fall into innocuous desuetude.

Since that time the Lehigh Valley Railroad people have been contented to follow the beaten path in locomotive designing. No better power is to be found in the country, and the company may of late years apply to itself the aphorism "happy is the country that has no history."

The great consulting room of a wise man is his library.—G. Dawson.

the class in examination, the majority answered by describing the shape of a man's head or body, or in some other manner going into the details of the human anatomy. The others answered that the reason for making them elliptical is that the covers may be placed on the inside, an operation which would be impossible

atre troupe were playing "Damon and Pythias." The most pathetic scene of the play is the last act, where Damon is about to be led to execution, and is straining his eyes looking for a friend to bring a reprieve, and frantically calls out, "Is he coming?" At this exciting moment the sound of a locomotive whistle was heard, and some wag in the audience shouted, "He'll be here by next train," and the tragedy was converted into a roaring farce.

The electric light was first obtained by Sir Humphrey Davy in 1843, but recent improvements by Edison and Brush have made its general use possible.—Journal of Education.

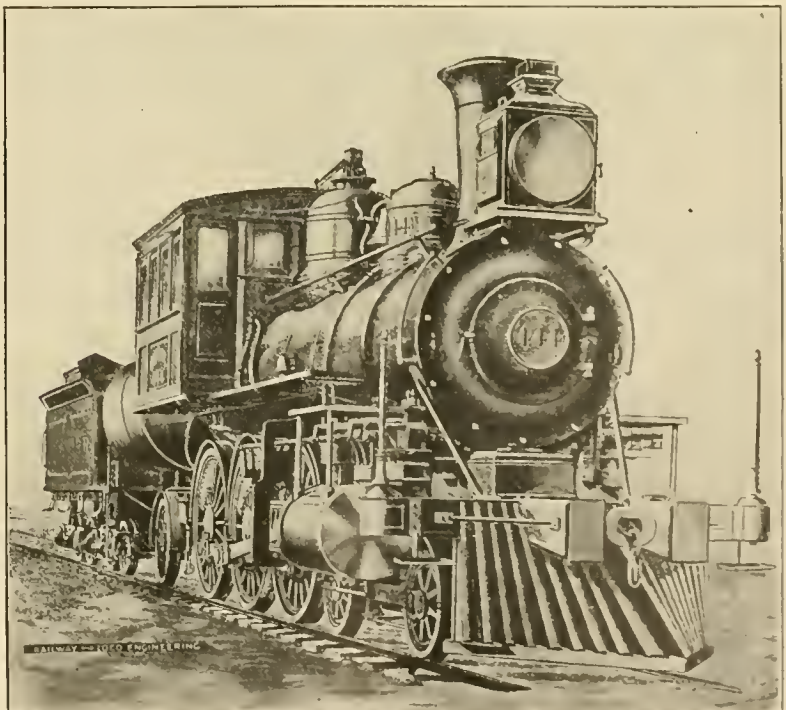

FIG. 7. STRONG'S "DUPLEX" LOCOMOTIVE.

### Bogie Well Wagon

A very interesting type of what is called a well bogie wagon has lately been built by the Leeds Forge Co., Ltd., for the Cheshire Lines Committee, operating between Manchester and Liverpool, from the designs of Mr. J. G. Robinson, the chief mechanical engineer of the Great Central Railway Company of England, and is intended for the conveyance of boilers, large castings, and other loads of unusual proportions. The part known as the well, or the sunken body of the car between the trucks, is provided with eight circular links on each side, held to the outer sill by eye bolts, and these circular links are for the purpose of passing ropes or chains through to hold the load in position. The car is intended for a maximum load of about 89,600 lbs., or, as we would approximate it, 90,000 lbs.

At first sight the car body, which hangs on links suspended from the trucks, would appear to be able to sway backward and forward parallel to the track sufficiently to bump the bulkheads against the truck frames, but this is not the case. The four sides are made of steel I-beams 9 ins. deep with 7 in. flanges and weighing 58 lbs. to the foot. These beams are spaced so as to give a width of 7 ft. 5 in. over plates in the central portion of the well. The two outside sills are offset 6 ins. each, close to the trucks, so that they pass outside the truck frames. The two centre sills have an offset of 4 ins. each, approaching one another and before they run under the truck frame. The truck frame is built up of angles and plates and

webs of the I-beams and are  $4\frac{1}{4}$  ins. in diameter and about 40 ins. long. Between the I-beam webs there are conical spacing pieces on the pins made of cast steel, and these prevent any side shifting of the hangers. The hangers are, of course, free to swing on the pins, and side motion is provided for by having the eyes through the hangers struck to the arc of a circle, the bell mouths being outward. The body of the car, therefore, as far as the pins and hangers are concerned, is free to swing in any direction within certain limits, and may be described as practically floating between the trucks. The top centre casting, as we said, consists of a hollow cylinder strongly ribbed on the outside. Into this hollow cylinder the bottom centre casting, which is the male casting, fits. It consists of a flat plate riveted to the top flanges of the two centre sills and having a heavy centre base slightly rounded, and standing up sufficiently to be completely enclosed in the hollow cylinder of the top casting. Through the two centre castings a  $4\frac{1}{2}$  in. king pin is passed, this pin having a head rounded on the under side and resting in a cup shaped recess of the upper casting.

The centre castings and the king pins are therefore capable of a slight movement in all directions, and this with the motion allowed by the hangers, permits the trucks to readily adjust themselves to curves and inequalities of the track. The hangers and pins support the weight of the body and the load, and the massive centre castings preserve the distance be-

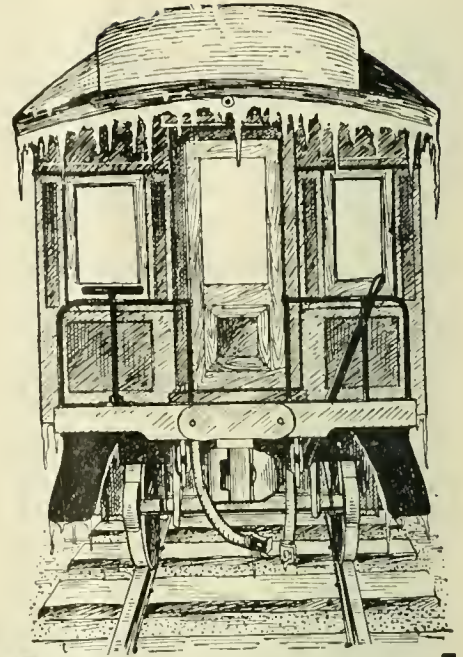

## The Cold Test

With the bleak, cold weather comes more or less imperfect action of the air brakes, and worry and trouble for the engineer as a result. If nothing is done to relieve this condition, you will be bothered all winter, and consequences may be serious.

When the air brake system is lubricated with Dixon's Graphite Air Brake and Triple Valve Grease the brakes respond sensitively to all reductions of pressure. Even in the coldest winter weather this grease will not stiffen and result in emergency action of the brakes when service application is wanted.

Get "proof" sample No. 69-I and make some trial tests on your engineer's valve and angle cocks.

**JOSEPH DIXON  
CRUCIBLE CO.  
Jersey City, N. J.**

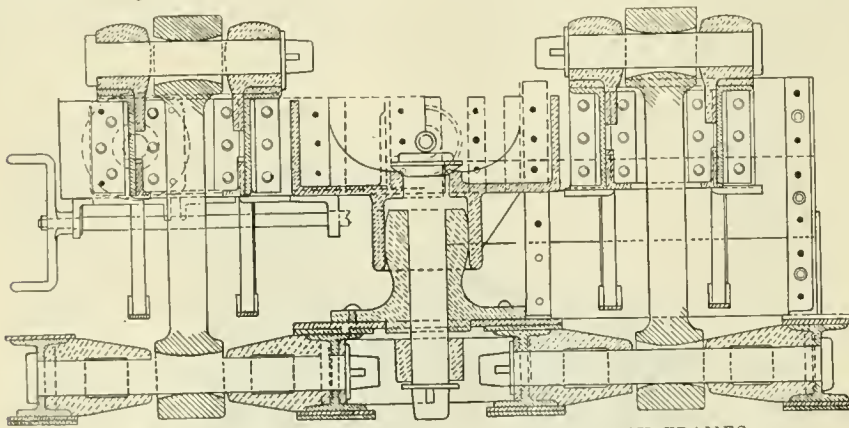

METHOD OF ATTACHING CAR BODY TO TRUCK FRAMES.

the truck bolster is of substantial and rigid construction. This truck bolster carries a heavy centre casting of peculiar construction. The centre of this casting is a deep, strongly webbed hollow cylinder 10 ins. in diameter and about 8 ins. deep. The truck bolster also carries on each side heavy steel castings through which the two top hanger pins pass. The pins are 4 ins. in diameter and 26 ins. long. These pins support hangers  $4\frac{1}{2} \times 2\frac{1}{2}$  ins., the eyes of which are 8 ins. wide.

The lower hanger pins pass through the

between the trucks, and prevent a pull at one end of the car from moving one truck without also at once giving motion to the car.

The sills of the car are laterally braced every 4 ft. by  $\frac{3}{4}$  in. plates secured by knees to the webs of the beams. Well plates  $\frac{1}{2}$  in. thick riveted to the upper faces of the lower flanges give the car a sort of continuous floor between the I-beam girders. A series of holes are drilled through the well plates to allow water to drip out of what otherwise would be pockets between the webs and the cross

# GOLD Car Heating and Lighting Co.

Manufacturers of

**ELECTRIC,  
STEAM AND  
HOT WATER  
APPARATUS  
FOR RAILWAY CARS**

**EDISON  
STORAGE  
BATTERY  
FOR RAILWAY CAR  
LIGHTING**

Largest Manufacturers in the World  
of Car Heating Apparatus

Catalogues and Circulars  
cheerfully furnished

Main Office, Whitehall Building  
17 BATTERY PLACE  
NEW YORK

braces. The sills, or girders, of this car are reinforced by  $\frac{3}{8}$  in. plates  $9\frac{1}{2}$  in. wide, laid on top and underneath the flanges and riveted thereto. There are two on top and four on the bottom, but the central portion of the car, for a distance of 23 ft., has a third flange plate on the under side, and for a distance of 20 ft. in the centre a fourth reinforcing flange plate is run along the underside of the girder flanges. This plate is  $9\frac{3}{4}$  ins. above the rail, while the lower plate at the hangers is 9 ins. above the rail. This constitutes the minimum clearance of the



FORTY-TON WELL WAGON ON THE CHESHIRE LINES.

car. The girders have a chamber of 2 ins. at the centre, so that the top of the highest flange plate on the upper side of the girders, at the centre of the car about  $24\frac{1}{2}$  ins. above rail level. The bulkheads, or upright partitions, which form the ends of the well, are made of braced plates faced with  $2\frac{1}{2}$  in. oak plank.

Some of the principal dimensions are as follows: Length, over buffers, 59 ft. 3 in.; width, over headstocks, 7 ft. 3 in. The length of the well is 32 ft., and its width 7 ft. 5 in. The distance from rail level to the floor of the car at the ends is 1 ft.  $8\frac{1}{2}$  in. There are two four-wheeled trucks or bogies, the centres of which are 44 ft. 9 in. apart. The wheels have a diameter on tread of 4 ft. 6 in., and the bogie wheel base is 6 ft. 3 in. The journals, both on inside and outside of the wheels are 8 in. by  $5\frac{1}{2}$  ins., thus giving 16 bearings in all. The axle boxes are set in jaws and have overhung springs. The centres of journals are 6 ft. 4 in. apart longitudinally. The buffer height is 3 ft.  $5\frac{1}{2}$  ins., and the centres of buffers 5 ft.  $8\frac{1}{2}$  ins. If loaded to its full capacity the car will carry 40 long tons, but if loaded with a central space of 12 ft. the carrying capacity is 25 long tons. This well wagon, which is what we would call a special steel platform car, is fitted with a hand-brake on one truck only, applying one brakeshoe to each of two wheels. This is intended to hold the car on a siding or where required and not for the purpose of retarding motion when running in a train.

The patterns which adorn cashmere shawls are copied from the leaf of the begonia.

## Looking for Facts.

Confucius, the great Chinese philosopher, stated that "if you seek for realities your desires will be fulfilled." This is particularly true in mastering the mysteries of mechanical contrivances. The difficulty is in knowing the shortest and best route in the search for information in regard to the realities that lie hidden from the untutored eye. The young railroad man encounters many mysteries when he enters on his high calling. He needs information. He should seek for it and his desires will be fulfilled.

Right here, RAILWAY AND LOCOMOTIVE ENGINEERING supplies the necessary adjunct. Its pages are filled with the expressions of the best thoughts of the leading railroad men of our time. It has met the universal approval of the leading railway men throughout the world. The price, \$2.00 a year, places it within the reach of every railroad employe.

"Twentieth Century Locomotives," Angus Sinclair Co., deals comprehensively with the design, construction, repairing and operating locomotives and railway machinery. First principles are explained. Steam and motive power is dealt with; workshop operations described, valve motion, care and management of locomotive boilers, operating locomotives, road repairs to engines, blows, pounds in simple and compound engines; how to calculate power, train resistance, resistance on grades, etc. Shop tools explained. Shop recipes, definitions of technical terms, tables, etc. Descriptions and dimensions of the various types of standard locomotives. The book is well and clearly illustrated and is thoroughly up to date in all particulars. years." Price, \$2.00.

"Locomotive Engine Running and Management," by Angus Sinclair, is an old and universal favorite. A well-known general manager remarked in a meeting of railroad men, "I attribute much of my success in life to the inspiration of that book. It was my pocket companion for years." Price, \$2.00.

"Practical Shop Talks," Colvin. This is a very helpful book, combining instruction with amusement. It is a particularly useful book to the young mechanic. It

has a stimulating effect in inducing him to study his business. We sell it for 50 cents.

"Examination Questions for Promotion." Thompson. This book is used by many master mechanics and traveling engineers in the examination of firemen for promotion and of engineers likely to be hired. It contains in small compass a large amount of information about the locomotive. Convenient pocket size. We cordially recommend this book. It sells for 75 cents.

"The 1904 Air Brake Catechism." Conger. Convenient size, 202 pages, well illustrated. Up to date information concerning the whole air brake problem, in question and answer form. Instructs on the operation of the Westinghouse and the New York Air Brakes, and has a list of examination questions for enginemen and trainmen. Bound only in cloth. Price, \$1.00.

"Compound Locomotives." Colvin. This book instructs a man so that he will understand the construction and operation of a compound locomotive as well as he now understands a simple engine. Tells

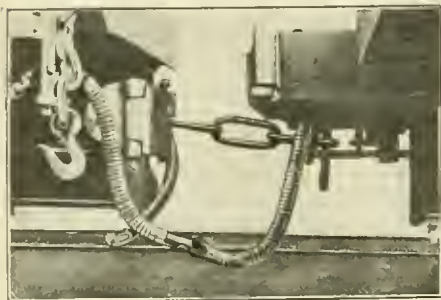

CARS COUPLED ON PASSENGER TRAIN IN CUBA.

all about running, breakdowns and repairs. Convenient pocket size, bound in leather. \$1.00.

"Catechism of the Steam Plant." Hemmaway. Contains information that will enable a man to take out a license to run a stationary engine. Tells about boilers, heating surface, horse power, condensers, feed water heaters, air pumps, engines, strength of boilers, testing boiler performances, etc., etc. This is only a partial list of its contents. It is in the question and answer style. 128 pages. Pocket size, 50 cents.

"Care and Management of Locomotive Boilers." Raps. This is a book that ought to be in the hands of every person who is in any way interested in keeping boilers in safe working order. Written by a foreman boilermaker. Also contains several chapters on oil burning locomotives. Price, 50 cents.

"Locomotive Link Motion." Halsey. Any person who gives a little study to this book ceases to find link motion a puzzle. Explains about valves and valve motion in plain language. Price, \$1.00.

Mark Twain, Cold Steel, Saw and Jail.

In one of his many stories Mark Twain tells of how he was once private secretary to a senator. This senator was approached by a deputation of his constituents, who sent him a petition in favor of a railway which it was thought would go past the town without touching it. The senator was in a quandary as to how to deal with the petition and told Mark Twain to give them all an evasive answer which would gain time.

The secretary wrote at once to the principal petitioners and in pursuance of his instructions ignored the railway matter altogether, but suggested other things. "What you want in your town," he wrote, "is a first class jail, and the senator will see what he can do to get one." The petition had ended with the time honored words, "—and your petitioners will ever pray," to which Mark replied for the senator, "I am glad to hear it, it will do you good."

Now this brings us down to the fact that Warren County in the state of Mississippi has determined to have a first class jail, though Mark Twain and the Senator have had nothing to do with it, and for the purpose of having it strictly first class as a place of detention, the board of county supervisors employed a local steel and iron worker of high repute named John Christian to make a practical test of some "unsawable" steel bars which were used in the construction of the extra burglar proof cages with which the first class jail was being equipped. Mr. Christian armed himself with a No. 250, twelve-inch hack saw made by the L. S. Starrett Company of Athol, Mass., and sawed through the cold steel unsawable bar in four hours in presence of the president of the county board and the first class jailer. The people who made the cold steel bars will likely be asked for other and still more unsawable bars for the cages, but in the meantime the Starrett Company will go on supplying hack saws to all honest men who are desirous of obtaining them. These saws will work equally well on other things beside jail bars, and if you want a good hack saw you have the address of the makers.

#### Railway Telephones.

The telephone now plays an important part in railroad operation, not that it has displaced the telegraph for train dispatching, though in certain cases of failure of the telegraph line it has been used as a temporary substitute. The main use of the telephone in railway service is to bring officials into close touch with one another and facilitate communication, which is naturally quicker and fuller than if carried on by correspondence.

On some roads the telephone line is made of copper, and like the one used on the C. B. & Q., the copper circuit is used

## JUST PUBLISHED

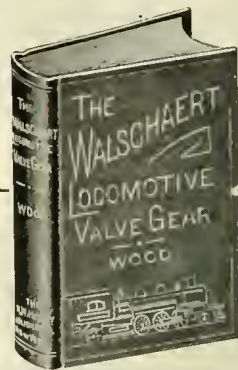

### The Walschaert Locomotive Valve Gear

By W. W. WOOD

Nearly 200 Pages, Fully Illustrated.

PRICE \$1.50

The valve gear is the principal, and most vital, of the parts of any engine, and the cumbersome and unwieldy Stephenson link motion that has been in general use in this country for over half a century is rapidly being displaced by the lighter, and more accurate, valve gear of the Walschaert type.

It required years of study and experience for many an intelligent man to gain merely a fair understanding of the principles of the common link motion, and now the locomotive engineer, the shop man, and the motive power official are being demanded to post themselves on the newly adopted Walschaert Valve Gear.

But it will not take years—nor months—to thoroughly understand the Walschaert valve motion if you possess a copy of this book. The author takes the plainest form of a steam engine—a stationary engine, in the rough, that will only turn its crank in one direction—and from it builds up a modern locomotive, equipped with the Walschaert valve gear, complete.

This Book is Composed of Four General Divisions

The *First Division* explains and analyzes the Walschaert valve gear. There are no algebraical formulas in this Division—just plain talk.

In the *Second Division* the designing and erection of the Walschaert gear is treated from the viewpoint of the scientific engineer and master mechanic. In this Division are contained diagrams and formulas that will enable any machine shop foreman to design and lay out the Walschaert valve gear for any locomotive, with hints on inspection of the gear and rules for setting the valves. Here are two diagrams, in particular, on folding sheets, that show the position of the valve, link and all other parts of the gear, when the main crank-pla is at nine different points in its revolution—both with the outside admission D-slide valve and the piston valve of inside admission. Separate cardboard models of these two valves to be used in connection with the diagrams are contained in a pocket in the book, and these two diagrams and valve models, alone, are worth more than the price of the book to any master mechanic, shop foreman, machinist, engineer or fireman.

The *Third Division* has to do with the actual work of the Walschaert valve gear on the road, and here is disclosed the advantages obtained from its use and the reasons why it is superior to the common, double-eccentric link motion.

The *Fourth Division* is composed entirely of "Questions and Answers on the Walschaert Valve Gear," which form a condensed, but complete, set of instruction—not only descriptive of the valve gear, etc., but these questions and answers also refer to all of the common breakdowns on the road that may happen to a locomotive equipped with the Walschaert motion; and this Division is representative of the whole book; the matter is so plainly written, and complete, that this last Division of the work will enable any engineman who has a common school education to pass any examination on valve motion, or the Walschaert Gear.

Send for a special circular of this book as well as Our Other Railroad Books.

Copies of this book sent prepaid on receipt of price.

**AGENTS WANTED** Write for our special terms. You can make equal to a month's pay selling our books on the slide.

**THE NORMAN W. HENLEY PUBLISHING CO.**  
132 Nassau St., New York, U. S. A.

# 3,303 Salaries Raised



This is a 12-months' record showing the number of men who have voluntarily reported an increase in salary and advancement in position as a direct result of the help received by them from the INTERNATIONAL CORRESPONDENCE SCHOOLS. Their names, addresses, and letters are open for public inspection and investigation.

This marvelous record, which shows only a small part of the actual results accomplished, tells better than words how the I. C. S. enables men to make more money by fitting them for more important positions. These 3,303 were, most of them, poorly paid and had no chance of advancement until they called to their assistance the I. C. S.

Are **You** at this minute situated as they were? If so, why not do as they did? Why not mark the coupon below and have the I. C. S. show you, as it has done so many thousands of others, how you can qualify yourself in your spare time and in your own home to earn a high salary in the occupation of your choice?

*There is nothing peculiar about your case.* There is no obstacle either of time, money, or location to hinder you. It is merely a matter of your own ambition. Mailing this coupon places you under no obligation whatever. Take your first step toward a higher salary by sending in this coupon **NOW**.

- |                         |                    |
|-------------------------|--------------------|
| 75 General Foreman      | 25 Mining Engineer |
| 76 R. R. Shop Foreman   | 22 Architect       |
| 77 R. R. Trav. Engineer | 1 Bookkeeper       |
| 78 R. R. Trav. Fireman  | 2 Stenographer     |
| 79 Locomotive Engineer  | 3 Ad Writer        |
| 80 Air-Brake Instructor |                    |
| 81 Air-Brake Inspector  |                    |
| 82 Air-Brake Repairman  |                    |
| 16 Mechanical Engineer  |                    |
| 13 Mechanical Drafts.   |                    |
| 12 Electrical Engineer  |                    |
| 83 R. R. Con. Engineer  |                    |
| 19 Civil Engineer       |                    |
| 24 Bridge Engineer      |                    |
| 9 Chemist               |                    |

**International  
Correspondence  
Schools**

Box 805, Scranton, Pa.

Please explain without further obligation on my part, how I can qualify for a larger salary and advancement to the position numbered \_\_\_\_\_

Name \_\_\_\_\_

St. & No. \_\_\_\_\_

City \_\_\_\_\_

State \_\_\_\_\_

for quadruplex telegraphy as well as for long-distance telephone work. Another economical arrangement which has been made, is to string a pair of soft iron wires, which forms a "round" circuit for the telephone, and each wire of the pair is made use of as a separate telegraph line.

The whole of the economy developed by the use of a comprehensive railway telephone service is not found in the advantageous use of the wires for the telephone and the telegraph. As business constantly fluctuates, the prompt reporting of what has been secured, what is in sight, together with the necessary arranging of details, renders it possible to save the running of unnecessary trains or facilitates the concentration of crews where and when most needed.

Strategy and tactics are primarily military expressions, but may be used with fairness to definitely express the kind of results which may be peacefully achieved in railroad work. Strategy refers to the handling of the army in the endeavor to take up good positions or in so bringing them into the field that the greatest advantage may be gained. Strategy in this

## Locomotive Superheaters.

What was practically a descriptive history of locomotive superheaters was given Mr. F. J. Cole, of the American Locomotive Company in a paper recently read before the Central Railway Club. Mr. Cole, in opening, said, the use of superheated steam on locomotives has progressed very rapidly in the last eight years, and at the present time about 1,600 engines are so equipped in Europe, and 260 in use, or under contract, in the United States. The Canadian Pacific Railway has 200 superheater engines.

In 1848, the records show that six locomotives built by John Cockerill, of Seraing in Belgium, had in essence a superheater device which consisted of an enclosed space around the smokestack. In 1850, an Alsatian engineer named Hirn experimented with superheaters which gave a temperature of about 260° C. In 1855 Montety, of Toulin in France, constructed a scientifically designed superheater for locomotives. The method employed was that in the lower part of the boiler a large internal flue was placed, in



TYPICAL "McQUEEN ENGINE OF THE SEVENTIES.

sense is preparatory work, and the telephone freely used among the officials may be made of use in effectively handling the railroad army in securing of contracts or in occupying positions of advantage. Tactics refers to the actual maneuvering of the forces in the field when the day of battle has come, and has its analogue in the provision for the movement of the requisite trains when the shipments of freight have to be handled with a minimum expenditure of power and equipment. Perhaps under the head of railroad tactics might be included the use of the portable telephone system carried on trains which enables a crew to promptly advise headquarters concerning break downs on the line or obstructions to traffic and to obtain instructions much more quickly than if the transmission of a telegraph message were the only means of communication.

The Burlington is to bridge the Missouri river at Kansas City, at a cost of more than \$1,000,000, to take the place of the Hannibal bridge, built fifty years ago. —New York Commercial.

which pipes, both for saturated and superheated steam were run lengthwise and coiled around the outer inside diameter of the large flue, their ends being upward, and terminating in steam boxes in the smoke box.

In 1857 a patent was issued to W. M. Storm. His apparatus was a large internal flue, one end terminating in the smoke box and the other end extending through the firebox and protruding outside the back head. In this flue the superheating pipes were placed. A peculiar arrangement was patented in 1858 by O. Newton in which the superheaters were placed at either side of the top of the boiler. Stillman and Wilcox followed in 1859 with one placed on top of the boiler with a large flue extending lengthwise containing a number of superheating pipes. In 1860 Mr. J. Martin invented a device which was placed in the smoke box. Benjamin Crawford in 1863 made another front end arrangement which consisted in partitioning off the forward part of the boiler for the purpose of superheating the steam.

Coming to more modern times Mr. Wm. S. Hudson, superintendent of the Rogers Locomotive Works, patented in 1872 a smoke box superheater in which the upper part of the box was practically occupied by the superheating chambers. Still another form devised by Mr. A. Estrade appeared in 1882, and in 1890 a patent was granted to Messrs. J. B. Bossler and S. D. Stauffer for a device which appears from the illustration given by Mr. Cole to be better adapted to promote circulation than superheat steam.

It is however owing to the labors of Wilhelm Schmidt, of Wilhelmshohe, that



JURA-SIMPLON RY. ENGINE.

superheating made substantial progress. In 1898 the Prussian Government used the Schmidt devices. Schmidt had done well in stationary practice and through the interest of Herr Garbe, experimental applications of the superheater were made on locomotives in Germany. In 1901 the Canadian Pacific equipped a locomotive with the Schmidt superheater and its use resulted in considerable saving of fuel and water.

The later forms of Schmidt superheaters as used in Canada and to a large extent abroad, are of the fire tube type. In this apparatus the usual boiler tubes are replaced in the upper part of the boiler by a number of 5-in. flues. In each of these there are four U-shaped superheating tubes in pairs extending back to within 3 ft. of the firebox, connected at the front end to saturated and superheated steam tee headers.

In 1904 the New York Central applied the original form of the Schenectady superheater. The upper part of the boiler was supplied with fifty-five 3-in. flues in which superheating tubes of 1 3/4-in., outside diameter, and circulating tubes 1 1-16, were placed. In a later form of the American Locomotive Company's superheater the vertical headers are made detachable with independent bolting, so that any one of them may be removed for repairs without disturbing the rest of the apparatus.

Another form of superheater which has been applied to a number of Canadian Pacific engines is a development of Messrs. Vaughan and Horsey, of that road. The reports from the use of this apparatus are very satisfactory and high temperatures have been obtained. The character-

istic of this form is the use of two comb-like headers with fingers cast integral. One of the headers is in the upper part of the smoke box for saturated steam, and has fingers extending downward, the other just below the centre of the smoke box with fingers extending upward, for superheated steam arranged in alternate rows for connection to the superheating tubes. These tubes are connected by means of a cross to the front of the fingers and arranged in groupes of four. Beginning with the one which Mr. Roger Atkinson applied in 1901, the Canadian Pacific have constantly used superheaters and now have more locomotives equipped with this device than any other line on the continent.

Speaking of the whole question of superheated steam as applied to locomotives, Mr. Cole concluded his interesting paper by saying "The superheater presents the possibility of economy in fuel, increased capacity for steam-making of any given boiler and an increased cylinder capacity, because of the absence of moisture in the steam. Among the other advantages offered by superheating is an important one in connection with the question of boiler pressure. Not only may locomotives with rather small boilers be considerably improved in steam-making ability, but pressures may actually be reduced in connection with superheating, to a limited extent, without noticeable loss of power. In operation it has been noticed that the boiler pressure of a locomotive using superheated steam may vary within wide limits during a run without such decrease in speed as would follow the same fluctuations in pressure in a locomotive using saturated steam. This becomes rather important from an operating standpoint. Viewed as a question of economy, the

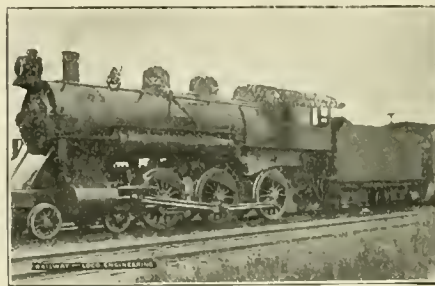

MODERN TEN-WHEELER.

superheater renders it possible to continue the use of old locomotives, which, without the application of superheaters, would be considered out of date, and when applied to the largest and most modern of passenger locomotives, the economy in fuel and steam appears in connection with the capacity of the fireman to produce the necessary horse-power."

If you find, in looking over your copies of RAILWAY AND LOCOMOTIVE ENGINEER

# Tate Flexible Staybolt



Strong

Effective

Economical

Flexibility

Durability

Simplicity

Holds firebox sheets securely together, and accommodates itself to the unequal expansion of the plates.

## FLANNERY BOLT COMPANY

PITTSBURG, PA., U. S. A.

Suite 308, Frick Bldg.

B. E. D. STAFFORD, - - General Manager  
Write us for Reference Book

# Homestead Valves

Straightway, Three-way and Four-way, and

# Homestead Locking Cocks

Are Famous the World Over

They cost more, but are worth very much more than other makes. You try them and see.

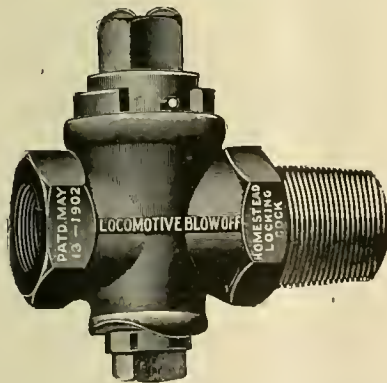
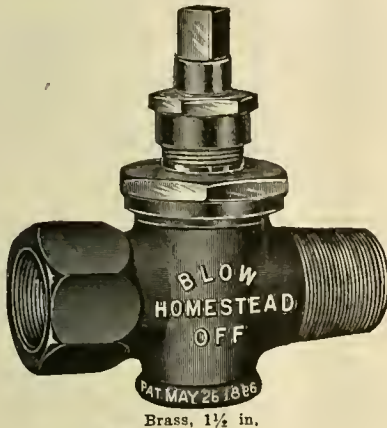

## HOMESTEAD VALVE MFG. CO.

WORKS: HOMESTEAD, PA. PITTSBURG, PA.

## American Locomotive Sander Company

13th & Willow Sts., Philadelphia, Pa.

Proprietors and Manufacturers

LEACH, SHERBURNE, DEAN, SANDERS  
HOUSTON, "SHE" and CURTIS

### THE ROBERT W. HUNT & CO.

Bureau of Inspection, Tests and Consultation,  
1137 THE ROOKERY, CHICAGO.

66 Broadway, New York.

Park Building, Pittsburg.

31 Norfolk House, London, Eng.

Inspection of Steel Rails, Splice Bars, Railroad Cars, Wheels, Axles, etc. CHEMICAL LABORATORY—Analysis of Ores, Iron, Steel, Oils, Water, etc. PHYSICAL LABORATORY—Test of Metals, Drop and Pulling Test of Couplers, Draw Bars, etc.

Efficiency Tests of Boilers, Engines and Locomotives.

ING for the year 1906, that you are short one or two or more copies, perhaps lent to a friend and not returned, or perhaps taken without your leave at all, remember that a good way to preserve the whole thing intact is to get a bound volume, price \$3.00, and these volumes are ready now. Send in your orders early, as only a limited number are bound up. If you have not been a subscriber for the paper, get the 1906 volume and subscribe for 1907; but we wish you a happy New Year in any case.

### Automatic Drill Grinder.

A good tool practically becomes a bad tool if it is not kept in proper repair, and in this respect a first-class drill may become a very poor one for want of being correctly sharpened. Sharpening a drill is done by grinding the cutting end at such an angle that the cutting edges may

Referring to the tool itself which we here illustrate it may be said that the design is such that it insures equal height and even cutting on the lips of the drill. The wear on the face of the emery wheel is uniform and in consequence no equalizing wheel is used on the Dahl grinder. Gauges are provided on the head of the machine for adjusting the grinding wheel for various diameters of drill, and a micrometer is provided for adjusting the wheel so as to compensate for wear.

The whole design is neat and the machine weighs 1,900 lbs., and when it leaves the manufacturer's, it is furnished with one large emery wheel for grinding, one small wheel for pointing, and the required rest for the free end of the drill, and bushings for the taper shanks. A wide range of automatic feed is provided and each machine is furnished with

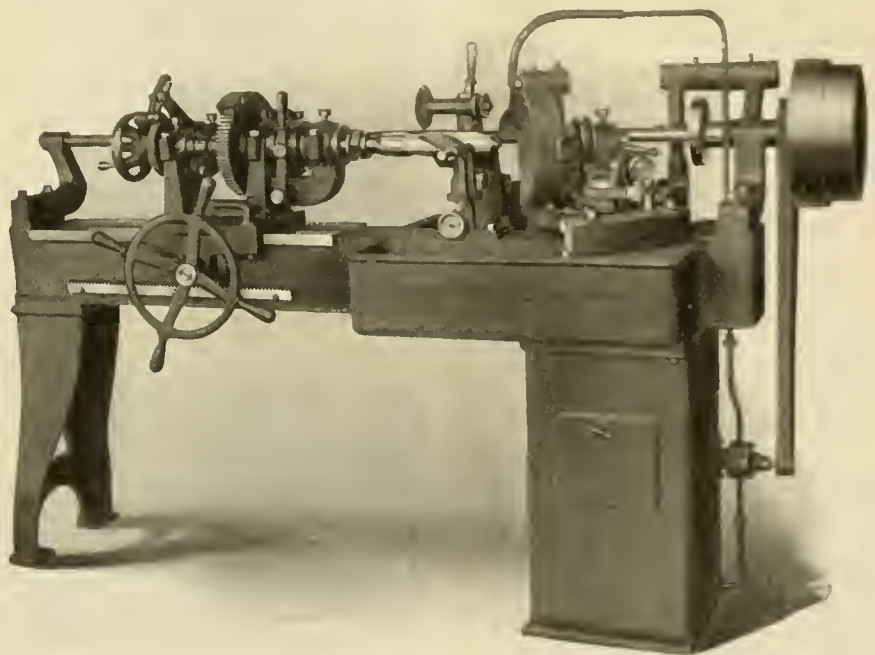

DAHL AUTOMATIC DRILL GRINDER.

be keen and the penetrating power of the drill up to the maximum.

It is with the desire to meet these requirements that the firm of Manning, Maxwell & Moore, of New York, have got out a tool known as the Dahl Automatic Drill Grinder. This machine is capable of grinding drills from 1/2 to 3 1/2 ins. in diameter, and this is done automatically. An unskilled man, by the use of this tool, grinds a drill at the true angle without trouble, and it would be a difficult operation for a skilled man without some such tool as the Dahl. One of the reasons why a laborer may tackle the job is that no centering of the drill is required as the grinding takes place while the drill is being revolved, and it is so equipped that simple and rapid adjustment can be made in dealing with drills of different sizes. The drills are pointed after being ground without their being removed from the machine.

countershaft, water attachment and the necessary wrenches. Any further information will be gladly given by the builders, 85-89 Liberty street, New York.

### Salt Water for Dusty Roads.

It appears from one of the recent consular reports that the Medical Society of Bordeaux, in France, have called attention to the evils arising from dusty roads. Sea salt and sea water have been proposed as remedies which do not cost very much. The idea of using sea salt appears to be based upon its property, especially when in large grains, of absorbing the moisture of the atmosphere. It is this property that is relied upon to do the work, and it is claimed that salt will dampen the dust and thus prevent its dissemination.

Doctor Carl, an eminent chemist of Bordeaux, exploits the merits of sea water. He says that when salt extracted from sea water becomes damp it is be-

cause of the impurities it contains. These being generally carbonate of magnesium and calcium, and they provoke this liquefaction. It has been suggested that these salts might be put into the ordinary water used for sprinkling the roads. These salts, however, as prepared in the laboratory, or as found as residuum in the factory, have a market value which would make their general use very expensive if applied to roads. Doctor Carl points out that these salts abound in sea water, from which, if evaporated in great shallow trays by the rays of the sun, the different salts crystallize in order of insolubility, chloride of sodium being the first to separate, while the others, more soluble, accumulate in the remaining water. A few quarts of this "mother sea water," having no value, mixed with a ton of ordinary water. Doctor Carl declares, will be found most efficacious in laying the dust and preventing its dissemination.

The idea here is to use the sea salt on roads on which carriages and automobiles run, but if it was found to be satisfactory on country roads, it might be found useful on railway lines where the ballast is excessively dusty.

The latest catalogue and price list of the Crandall Packing Company has come to our office. This company are manufacturers of improved steam, ammonia and hydraulic packings. The factory and general office is in Palmyra, N. Y. The catalogue has been beautifully printed and is well arranged and is altogether a very satisfactory reference book to order from. Each page is devoted to just one thing. The name of the particular brand of packing is printed in large clear type at the top. Then comes an excellent half tone representation of the packings, cut diagonally at one place so as to reveal the internal structure, at a glance. Its designating number is given and a brief description follows which tells what the packing ring is suitable for, and how made. The price per pound is placed conspicuously at the bottom of the page. The catalogue has been printed on specially prepared paper and is a fine example of the art of catalogue making. The Crandall Company, which have offices in New York, Chicago, Seattle, as well as Palmyra, will be happy to supply a copy of the catalogue to anyone interested enough to ask for one.

Practically every railroad yard in the Pittsburgh district is to be enlarged early next spring, and in some cases the capacity of the present yards will be doubled, as a result of the present congestion of freight. This will mean the expenditure of millions of dollars and will enable the initial lines to handle many thousand additional cars next year.—New York Commercial.

The Boston branch of the H. W. Johnson-Manville Company, of New York, moved last December into a new building at Nos. 55-57-59 High street, Boston. This entire building, which comprises seven floors are occupied by the offices, sales and shipping rooms of the company, and provide every facility for doing business comfortably, conveniently and promptly. Telephones connect with every division of the establishment and pneumatic tubes for prompt delivery of orders to the shipping rooms, etc., have been installed. Also, in order to handle to advantage their large and rapidly increasing business in the Southern States, this company have opened a New Orleans branch. This will consist of a large retail store, offices and warerooms, located in the large three-story building at the corner of Baronne and Perdido streets, New Orleans.

#### Electric Pumping Plant.

The ease with which automatic methods of control are adapted to the electric motor makes it convenient in some cases to use a motor for driving pumping machinery. It is generally a simple matter



FIG. 1. ELECTRIC PUMP HOUSE,  
L. S. & M. S.

to arrange a float-operated switch to open and close the motor circuit so that the expense of an attendant is eliminated and pumping can be done advantageously in an isolated locality. This is especially true along railway lines where, if current is available, an automatic electric pumping set may be installed to fill the water tanks for locomotives.

A very successful induction motor-driven pumping plant for this purpose is in operation on the Lake Shore and Michigan Southern at South Bend, Ind. The pumping plant consists of two Worthington single-stage turbine pumps, each direct connected to a six-pole,  $7\frac{1}{2}$  h. p., three-phase, 440 volt induction motor made by the General Electric Co. Two pumping sets are installed, so that in case one fails, repairs can be made without entirely shutting down the plant.

In Fig. 1 is shown a view of the pumping house. This is a round brick struc-

# XP

## IS THE MARK!

During the Holiday Season we are offering the following books at a reduced price when ordered as one set. The set is designed to be an appropriate and useful

### XMAS PRESENT

Give it to a friend or secure one for yourself. That is what the initials mean. Write for the XP set.

## Locomotive Engine Running and Management

—Sinclair

A book that has probably helped more enginemen than any other. Practical, reliable and brought up-to-date. Twenty-first edition ready.

Price, \$2.00

## Locomotive Link Motion

—Halsey

Treats link motion in a plain, practical way. Shows how it acts and tells why. Explains how valve motion is made and adjusted.

Price, \$1.00

## Firing Locomotives

—Sinclair

A readable elementary treatise on combustion, pocket size. Contains much ready and practical information.

Price, 50 cents

## Air Brake Catechism

—Conger

Convenient size, illustrated, 202 pages. Information concerning the air brake, question and answer form.

Price, \$1.00

These four books, price \$4.50, sold for \$3.50 if ordered as the XP set this month.

## Railway and Locomotive Engineering

136 Liberty St.

New York City

XP-\$3.50 XP-\$3.50 XP-\$3.50 XP-\$3.50



# MASTER CAR BUILDER IS OPEN FOR ENGAGEMENT

Young, Active, used to Big Prop-  
ositions; Capable of Installing  
Piece Work; Steel Car Work Hand-  
led; Not Afraid of Hard Work.

Further Particulars by Address-  
ing

**J. R. P.**

Care **ANGUS SINCLAIR CO.**

**136 Liberty Street, New York**

# THE UNION SWITCH & SIGNAL COMPANY

**CONSULTING  
AND MANUFACTURING  
SIGNAL ENGINEERS**

Automatic Block Signals—Electric  
and Electro-Pneumatic

Interlocking — Electric, Electro-  
Pneumatic and Mechanical

Electric Train Staff Apparatus

General Offices and Works at  
**SWISSVALE, PA.**

**DISTRICT OFFICES:**

**NEW YORK - - 143 Liberty Street**  
**CHICAGO - - - - Monadnock Block**  
**ST. LOUIS - - - - Frisco Building**

## THE TANITE CO. seeks the support of Railroaders because:

The man who uses a TANITE wheel will find it safe. Because pay for a TANITE wheel secures the greatest productive capacity. Because TANITE MILLS EMERY is mined in America and appeals to all who earn wages in America. Because TANITE grinding machines are practical.

THE TANITE CO. sells Emery, Solid Emery Wheels, Buffing Lathes, Guide Bar Grinders, Car Brass Grinders, Bench and Column Grinders, Surfacing Machines, Open Side Emery Planers, Saw Gummers, Automatic Planer Knife Grinders, Diamond Tools, Polishing Paste for Brass and Nickel, Emery Wheel Cutters and Dressers.

*The Tanite Co. builds special machines for special wants*

**THE TANITE CO.**  
**STROUDSBURG, PA.**

ture erected at the top of a concrete lined wall. The floor is of concrete, supported by I-beams, and is ten feet below the level of the ground. Upon this the pumps are placed, the interior arrangement being shown in Fig. 2. For keeping the pump room dry, four ventilating ducts are built into the wall of the pump house, the outlets appearing near the top of the pilasters in Fig. 1.

Each pump discharges water through a 2½ in. pipe connected with a 4-in. main



FIG. 2. THE 50,000 GALLON TANK, L. S. & M. S.

Fig. 3, is at the side of the tracks, about 100 ft. from the pumping station. The controlling device is arranged in the housing on the roof, the motors being started and stopped automatically by a small oil-switch operated by a float which has a vertical movement of about one foot.

The difference in level in the tank corresponds to 3,000 gallons of water. This is the average amount taken by a locomotive on this road, and the tank is refilled in about twenty-five minutes. The supply tank holds about 50,000 U. S. gallons and could supply fifteen locomotives within a few minutes if necessary. Such a demand is seldom made, and in actual practice the pumps stand idle for the greater part of the time.

The Pittsburgh Crushed Steel Company, Ltd., of Pittsburgh, Pa., are the makers of a product which finds a use in railroad repair shops. The company makes Diamond crushed steel, and diamond steel emery and rouge for the rapid polishing of granite, marble, stone onyx, brick, glass, metal, etc. Diamond steel emery is used for grinding in steam and air joints. It is made from exceedingly hard steel and is crushed to a fine, abrasive powder. Diamond steel emery is extensively used on many of the important railroads in this country. Write to the company for a sample and they will be also happy to tell you about the various grades and qualities which they make.

## O'Hoolihan Saves His Half Day.

BY E. J. MACK.

In building a railway track over streams or bays of lakes, it is customary to put up temporary trestles, and these are afterwards filled with rock, ballast, etc., by means of engines and trains of flat cars.

During the operation of filling, the foot of the piles sometimes "kick out" or shift, and when this takes place an effort is made by dumping material in one spot to check the movement. This work is often carried on in the winter after the ice has formed, and frequently the ballast will be dumped or ploughed off onto the ice until the ice is broken by the weight, the dumping is then continued into the hole.

It was while work of this kind was going on that John Michael O'Hoolihan, full private in the army of the Deep Cut & High Bridge Railway, lost his balance and went down through the hole into thirty-seven feet of water, accompanied by several tons of sand and gravel. Mr. O'Hoolihan's chances of ever seeing daylight again were about one in ten thousand, but on the off chance the stream of ballast was checked and one of his mates climbed down onto the ice to lend a hand in case the gentleman should see fit to return via the same route he started on. The material carried down with it a large quantity of air, and this naturally boiled up seeking outlet at the only opening in the eight-inch covering of the lake. Ow-

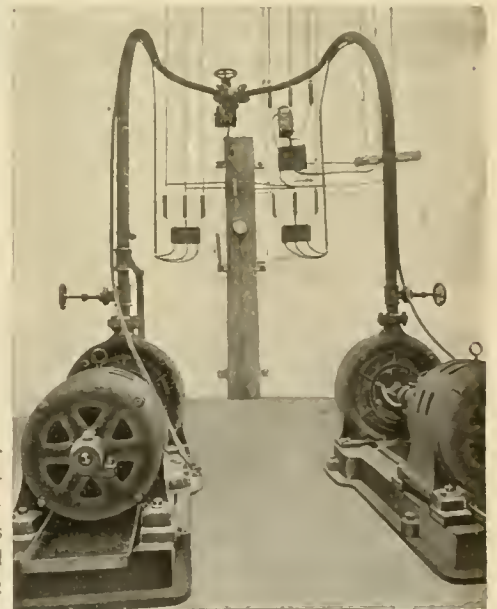

FIG. 3. ELECTRIC INSTALLATION IN PUMP HOUSE, L. S. & M. S.

ing to this circumstance and the low specific gravity of his body, he did boil up in the hole and was fished out, alive but unconscious; and after laying by the fire for a time was as good as new. It was just at this time I saw him, and knowing the breed, I told him I thought it a shame

for his foreman to "dock" him for the time spent under water.

By the twinkle of his eye I saw that he grasped the situation, and his "By the powers I'll see Cassidy about that," brought me with him to see fair play.



THE "INVICTA," CANTERBURY & WHITE-STABLE RAILWAY.

Cassidy was no dago himself, and when O'Hoolihan opened on him with an inquiry as to the truth of the report he was ready for him in a moment.

"And why shouldn't I dock you? What use were you to me while enjoying yourself among the fishes, tell me that?"

"True enough, sor, but sure I didnt lave the work of me own accord; me feet slipped and the blowed ballast drove me down."

"Be garry it did that, for I had a glimpse of you going. I did think that you had dropped a shovel and were going after it at first, but I know better now. But see if we cannot find a way out of it; you know the trouble I am having with that blessed trestle, and it would be a great help if I knew just what sort of antics it was cutting up down below there, so tell us how matters stand and we will see about the 'docking' after."

"Oh! Is it that you want to know? Sure, I am the boy; I can tell you all about it. When I first started for the hole me first thought was—O'Hoolihan, it's all day



THE PROCESSION.

wid you, and I will say that for a time, what wid the tons of gravel on me back, the unaccustomed feel of water and so on, I was a little confused at first, but pretty soon I saw what a grand chance it was to examine the feet of the trestle and

see what ailed the old thing anyway, that she wouldnt stand up dacent and square as she should. Well, sor, your troubles are not over wid her yet by a long shot; you see the bottom is all soft mud on a sloping rock, and the stone you put in from the land side has slid out, taking the feet from under her, and if you don't get some weight in on the other side pretty quick by the power she will go further, so there you are, and by that time I thought it was time to be getting back to me work, and so I started up, and on the way I bethot of a five-dollar bill I had in me vest pocket and put in me fingers to see if it was all safe, and low and behold it was gone, washed out by the water likely; the shock of that was dreadful, and I think I must have fainted, for the next thing I knew I was beside the fire all warm and snug. Do you think the company would make up the five to me, sor?"

"Not on your life! You should take better care of your money, me man; but I'll not dock you for the lost time, so I

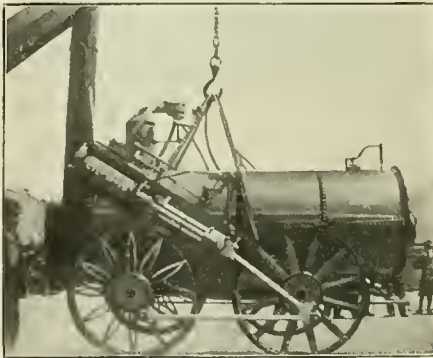

LIFTED FROM RAILS TO ROAD.

won't, so there, now, and see that you are not late for work in the morning."

**An Interesting Relic.**

An interesting ceremony was performed at Canterbury, England, last month, when the "Invicta" locomotive engine, which was constructed by George Stephenson about seventy-five years ago, was formally presented to the Town Council. A site had been provided in the old city moat, near the riding gate entrance to Canterbury. In presenting the interesting relic, Sir David Salomons said that the engine was used in the first public service for passenger traffic in 1830, some time before the "Rocket" ran between Manchester and Liverpool. It was a relic that would stand to the honor not only of Stephenson, the eminent engineer, but to England, who gave the steam railway system to the world. The Mayor of Canterbury accepted the gift on behalf of the city in the presence of a large assemblage. The engine had been at one time used on the Canterbury & Whitestable Railway.

**Locomotive Blow-Off Plug Valves**

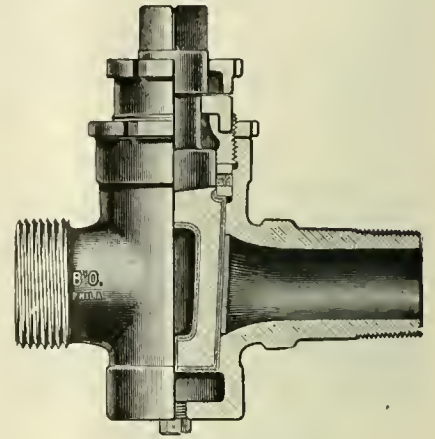
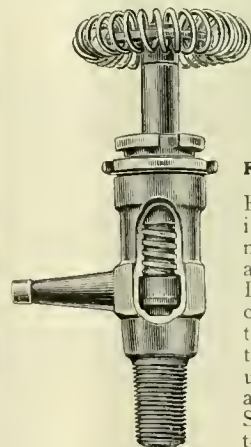

Fig. 9.

All Brass, extra heavy, with Cased Plug. For 250 lbs. pressure. Made with Draining Plug to prevent freezing.

**Locomotive Gauge Cocks**

**For High Pressure**



Bordo Self-Grinding Gauge Cocks, made with renewable Hard Bronze Disc. Opened and closed with a quarter turn. Guaranteed Steam tight under the most exacting conditions. Shanks Threaded to specifications for Locomotives.

Fig. 23, with Wheel.

**Swing-Joints and Pipe Attachment**

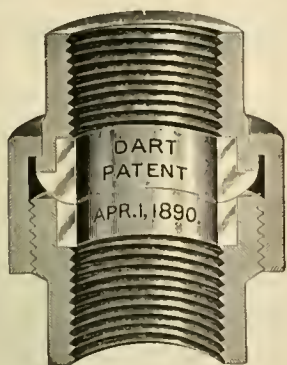

Fig. 33.

May be applied between Locomotive and Tender. These Swing-Joints are suitable for Steam, Gas, Air, Water or Oil.

**Complete Booklet on Application**  
**L. J. BORDO CO.**  
**PHILADELPHIA, PA.**

This illustration shows the form of construction of the  
**Dart Patent Union**



Every feature of construction represents the best points to insure stability and durability. The malleable iron pipe ends and nuts, in combination with bronze metal seats, are as near perfection as is possible to approach, and the sales to date indicate the public approval. There are none so good. For sale by all the principal jobbers in United States, Canada and Europe.

**E. M. Dart Mfg. Co., Providence, R. I.**  
 FAIRBANKS CO., SALES AGENTS.



# The Twentieth Century Master Mechanic

Won't use Solid Mandrels.  
 Cost too much, take up too much room and don't give satisfaction.

## Nicholson Expanding Mandrels

Take everything from 1 to 7 inch holes. Take up little room—always ready and you can buy four sets for the cost of one of the solid kind.

### Are You Using Them?

Catalogue tells you more about them.

**W. H. Nicholson & Co.**  
 Wilkesbarre, Pa.

### Metal Ties.

An interesting paper on metal ties was read recently before the members of the Railway Club of Pittsburgh by Mr. T. H. Porter, chief engineer of the B. & L. E. Ry. Experiments with metal ties have been made for some time under Mr. Porter's supervision and his observations are valuable. The experiments conducted by him lead him to believe the spikes may be driven home from time to time, but they do not so remain, but lift up to a less or greater degree depending on the solidity of the track, so that the primary function of the spike is to keep the rail from moving laterly.

Within the limits of ordinary vertical movement the rail is held down on the tie by gravity or the weight of the rail and its load. As a general rule, there is, though it be small, more or less play between the base of the rail and the spike. On account of this play there is a lack of firm and intimate connection between the rail and ties through the spike, between adjoining ties through the rail, and be-

preventing the rail from rolling, as it produced a lateral rigidity in the track structure independent of the ballast. The wooden tie naturally begins to deteriorate from the time it is put in place, the rate of deterioration increasing until it becomes necessary to remove the tie. The steel tie on the other hand maintains its section



PASSING THE REMAINS OF AN OLD ROMAN ENCAMPMENT.

and the bed under the tie does not have to be disturbed on account of the tie becoming soft, nor on account of the effective thickness of the tie becoming less due to rail or tie plate bedding into the steel.

The steel tie retains the same dimensions and efficiency, and it is possible throughout the life of the tie to maintain track of the same excellence as with all new ties. Mr. Porter quoted reports from Mr. Post, chief engineer of the Netherland State Railway, showing that steel ties weighing 125 lbs. laid in sand and gravel ballast, has decreased about 9 lbs. in 35 years, but were still good for 20 years' service.

In the important item of cost, he stated that the renewal of wooden ties costs from two to two and a half times the cost of the renewal of rails. Assuming that the steel tie can be procured at the same price per pound as the steel rail, and that the life of the steel tie will be one and one-



AT THE FOOT OF THE PEDESTAL.

tween the two rails through the ties. On account of this lack of firm and intimate connection, the vertical forces of the load on the rail are not instantly distributed to the other rail and adjoining ties. The vertical load is conveyed to adjoining ties in succession, and the lateral forces or blows are only resisted by the lateral stiffness of one rail until the single rail has moved the amount of the play in the connection between the rails and ties, thereby allowing a movement which aggravates the lateral blows or forces. A rigid connection between the rail and tie will certainly assist in bridging the load and in distributing the blows and forces to both rails and adjacent ties. In all metal tracks the instantaneous resistance of both rails and adjoining ties is obtained, but there is the added friction between rail and tie made by the fastening in the joints in advance of and following those on which the load directly rests.

Mr. Porter claimed that where steel ties are used less wear and more uniform wear of rails is obtained. This is accounted for by the better fastening, securing a better connection between rail and tie,



ON THE PEDESTAL.

half times that of the steel rail, the cost of tie renewal would be about equal to that of rail renewal. A great economy will thereby be obtained in the use of the steel tie, an important item in the economy being that the old tie can eventually be sold for scrap.

### Handy Drill for Tight Corners.

The Chicago Pneumatic Tool Company have recently designed and placed on the market a new "Little Giant" drill which is especially designed for doing work in close quarters and particularly in tight corners. Parts of that company's No. 4 Little Giant drill interchange with the one which works in awkward places, so

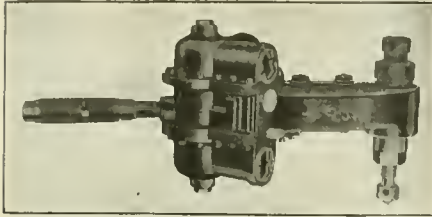

PNEUMATIC CORNER DRILL.

that repairs to the new tool may be readily and quickly made.

The corner drill, as it may be called, weighs 35 lbs. and is capable of driving a  $1\frac{1}{2}$  in. twist drill all right, and in case of emergency it can handle a 2 in. drill very satisfactorily. The spindle speed when running light is 150 revolutions per minute and under load, with 80 lbs. air pressure it goes at 100 revolutions per minute. The distance from the end of the socket to the end of the feed screw, when run down, is  $5\frac{3}{8}$  ins. The length of feed is 2 ins. and the distance from the centre of the spindle to the outside of the housing is 1 5-16 ins. The spindle is driven by gears instead of being turned by mechanism involving the ratchet principle and this gives a constant and steady spindle movement. Our illustrations give a good idea of the useful little tool, which is compact and neat in appearance.

Air when is compressed it becomes heated, that is because work has been done to it and work is simply pressure acting through space or distance. One of

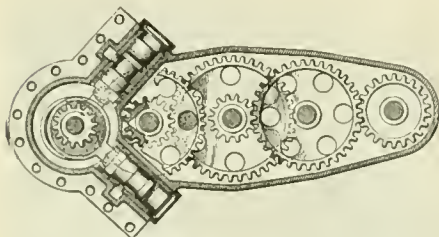

MECHANISM OF THE DRILL.

the dangers in air compression which the Joseph Dixon Crucible Company of Jersey City point out in their latest pamphlet, is the liability to explosion in air compressor cylinders when the heat generated in the process of compression is not taken away fast enough and rises above flash point of the oil used in the lubrication of the cylinder. The Dixon people state that their Ticonderoga Flake graphite

may be fed in, dry or with soapy water for lubricating air compressor cylinders. The graphite or the graphite and water will not explode even if the temperature does become high. A great deal of interesting data and information on the subject of air compressor and air drill lubrication is presented in the twenty-four page pamphlet got out by this company. It is sent free of charge to all who are interested in the subject. The pamphlet is illustrated by neat little pen and ink etchings.

### Railway Extension in Canada.

It is gratifying to learn that the Grand Trunk Pacific Railway is being extended with such rapidity that it is expected it will assist in handling the wheat crop of North Alberta in 1907. A new city is already planned and will be built at Prince Rupert, the Pacific terminus of the road. The harbor is finely sheltered and extends about ten miles in length by five miles in breadth, with an entrance over one mile in width. When the route is completed the distance between New York and Yokohama will be shortened by 1,500 miles, as compared with the route by San Francisco.

The Canadian Northern Railway is also extending rapidly. During the past year the line was opened to Edmonton and a branch to Prince Rupert, the extensions passing through a rich farming country with coal, iron and other minerals in abundance.

The Canadian Pacific Railway is still adding numerous important branches and is now a system of over 11,000 miles in all, extending from the Atlantic to the Pacific oceans. In point of equipment it compares favorably with the leading railways of the world.

The Union Switch & Signal Company, of Swissvale, Pa., have just been awarded the entire contract for the interlocking and signalling of the great terminal station now being built in Washington, D. C., by the Pennsylvania and the Baltimore & Ohio Railroad Companies. The installation will be electro-pneumatic, similar in its general characteristics to that in the railway yards of the Pennsylvania Railroad at the Union Station in Pittsburgh. The Washington installation, however, will be the largest and most complicated signalling and interlocking installation that has ever been constructed. The largest one previous to this was put in service at St. Louis at the beginning of the Louisiana Purchase Exposition, in 1903, and before that the most important was the electro-pneumatic interlocking system at the terminals of the Boston South Station. Both of these plants were also installed by the Union Switch & Signal Company.

## STANDARD MECHANICAL BOOKS FOR ROAD AND SHOP MEN BY CHAS. McSHANE.

### The Locomotive Up to Date

Price, \$2.50

### New York and Westinghouse Air Brakes

Price, \$1.50

### One Thousand Pointers for Machinists and Engineers

Price, \$1.50

All books bound in fine cloth.

AGENTS WANTED everywhere; write for terms and descriptive circulars. Will be sent prepaid to any address upon receipt of price.

## GRIFFIN & WINTERS

171 La Salle Street, CHICAGO

# TOOL STEEL

## Die Blocks Steel Forgings

First Prize awarded at the Louisiana Purchase Exposition, at St. Louis, for our TOOL STEEL when placed in competition with the best makes in England and Germany.

Write for Information and Prices.  
Specify McInnes Tool Steel when ordering.

# McINNES STEEL CO.

CORRY, PA.

# One Year and Eleven Months' SERVICE

WITHOUT REPACKING. ON

## High-Pressure Locomotives

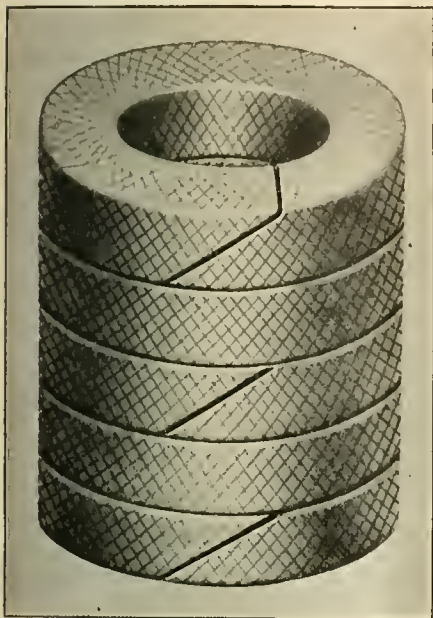

Style 300 TV.

A throttle failure is an absolute impossibility where Crandall's Throttle Valve packing is used.

IT WILL NOT BLOW OUT

## Crandall Packing Co.

FACTORY AND GENERAL OFFICE

PALMYRA, - - NEW YORK

BRANCHES

New York Cleveland

136 Liberty St. 9 So. Water St.

Chicago

52 West Washington St.

# Patents.

GEO. P. WHITTLESEY

MCGILL BUILDING WASHINGTON, D. C.

Terms Reasonable Pamphlet Sent

## Molding Machines

Vertical Vibration. Power Draft

ALL KINDS OF MACHINES

THE E. H. MUMFORD CO.

17th & Callowhill Streets, PHILADELPHIA, PA.

J. W. JACKMAN & CO., Ltd., 30 Victoria St., London, S. W.

### National Steel Tube Cleaner.

The salient feature of the National Steel Tube Cleaner which is here illustrated, is that each blade acts independently of the others and is spring-like in nature, which makes it snugly fit to the surface which is to be cleaned. It can be forced through the tube with very little effort and each plate of the cleaner removes any particles which may be within

Hyde Park works of the North British Co., Ltd., have the following dimensions: Cylinders, 20 ins. by 28 ins.; diameter of bogie, coupled and trailing wheels, 3 ft. 6 ins., 6 ft. 9 ins., and 4 ft. 3 ins., respectively; boiler pressure, 200 lbs. per square inch.

The Westinghouse Air Brake Company, of Pittsburgh, Pa., have issued a fine



NATIONAL TUBE CLEANER.

the pipe. Another advantage of this cleaner is that it can be adjusted to fit various sizes of pipe, and if one or more of its blades become broken by rough usage or wear, they can be readily repaired. The National Steel Tube Cleaner is made by the H. W. Johns-Manville Company of New York, who will be happy to give any further information on the subject to those interested.

souvenir album of the Master Car Builders and Master Mechanics' Conventions held at Atlantic City, N. J., last year. It contains the half-tonc reproductions of quite a number of photographs of the members of both associations, which were taken for the Westinghouse Company by their own photographer, who operated in the space occupied by the company's extensive and interesting exhibit at the end of steel pier and close to the sun parlor, which, by the way, was an appropriate place near which to take photographs. Most of the members thus appear in its pages. The work has been beautifully done, and the album is a work of art in every way. It is intended for distribution to members of both associations, and has been sent out with the compliments of the Westinghouse Company.

### British Block Trains.

BY A. R. BELL.

The new block trains, or vestibule trains, as they would be called in the United States, recently built at the Cowlairs works of the North British Railway, are for service between Glasgow and Edinburgh and Aberdeen. The Edinburgh section comprises one composite, two third-class and a luggage and brake van, and the Glasgow portion consists of a composite, one third-class and a luggage

The McConway and Torley Company, manufacturers of M. C. B. Couplers, Pitts-



NORTH BRITISH RAILWAY. BLOCK TRAIN.

and brake van, the two portions joining at Dundee. The passenger coaches each measure 58 ft. 4 ins. long by 8 ft. 6 ins. wide, and the luggage vans are 40 ft. 8½ ins. long by 8 ft. 6 ins. wide. There are two lavatories to each coach, and every fitting of the stock is of the most modern and luxurious character. The ten Atlantic locomotives for this service, built at the

burgh, Pa., have issued a handsomely bound and finely illustrated catalogue of 160 pages showing the latest improved developments in automatic coupler appliances, with illustrations of the earlier combinations as well, so that the work is an excellent guide for ordering repair parts of those equipments which have long been in service, as well as for the equip-

**METAL PRESERVATIVE PAINTS AND PRIMER**

for locomotives, boilers, stacks, front-ends, gearing, frame-work, metal roofs, etc.

Tell us your needs. Metal preservative paints have been our specialty for 22 years. Paints for all conditions.

THE  
**STANDARD PAINT CO.**  
Sole Manufacturers  
100 William St., New York  
CHICAGO ST. LOUIS

**CYLINDER BORING BARS  
VALVE SEAT ROTARY PLANING MACHINES  
CRANK PIN TURNING MACHINES**

*Write for Catalog*

**QUINCY, MANCHESTER, SARGENT CO**  
OLD COLONY BLDG. 114 LIBERTY ST.  
CHICAGO NEW YORK  
Machinery Sales Dept.  
PLAINFIELD, N. J.



**SKAT!**  
Off Comes the Dirt.

When the hands are smeared and stained with a greasy grimy coat of oil, soot, dust and dirt, rub on a little

**SKAT**

**The Best Hand Soap Known**

and see how quickly they're clean and soft again. SKAT is made to do what ordinary hard soaps can't do. Gets into the pores and loosens all the dirt so it simply rises off. Pure, effective and beneficial to the skin. 10 cents a can.

Write postal for free sample and we will tell you where to buy SKAT, or if not sold in your locality, will tell you how you can become our exclusive agent and make money selling it. Write to-day.

**THE SKAT MANUFACTURING CO.,**  
807 Park Street, Hartford, Conn.

ments with the latest improvements. Those who aim at a thorough knowledge of coupler equipment should send for one of these splendid catalogues, while those who imagine they are already familiar with such details should further instruct themselves by a perusal of the work. The manufacturers are ready in addition to furnishing such "standard" work as may be ordered, to design special couplers, or complete equipment to meet any given conditions.

**Twice as Fast.**

At the Schenectady shops of the American Locomotive Company, when they are in a hurry, and they generally are in a hurry up there if you can judge by the speed of the machines and the depth of cut and feed of the machines. Well, when

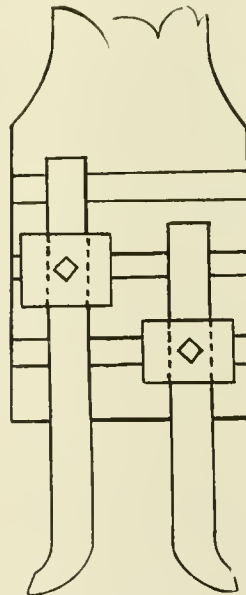

TWO TOOLS ON BUT A SINGLE HEAD.  
TWO CUTS THAT GO AS ONE.

they are in a hurry and want to make an old slotter double its output they put two tools in the machine and slot off the two inside faces of the forked end of one or more connecting rods at the same time. This is not particularly novel, and it is not confined exclusively to this shop, but it serves to show the spirit of the times as a straw on the surface of a stream may show the direction of the current or the position of the eddies. The curious thing about all this increased speed of production is that it does not seem to ever fully meet the demand or to glut the market. As a general rule, it seems to be true that the easier a thing can be made the more of those things will be wanted.

Owing to increase of business, the Cleveland office of the Crandall Packing Company, of Palmyra, N. Y., has moved from 9 South Water street to 805 Superior street, N. W., in the Wade building, where their stock has been greatly enlarged and will enable them to take even

better care of their stationary and marine business, which is being handled from the Cleveland office.

**No Back Blow.**

This little illustration represents a Frisco flue borer, or rather flue blower of the compressed air variety. It is equipped with 25 ft. of air hose and a stop cock. Its great feature is the shield or anti-dust contrivance on the front or blowing end. An inch or two of tube is inserted into the locomotive flue and air is turned on and dared to do its worst. The shield is up against the flue sheet and prevents air sneaking back into the fire-box when pushed into a blocked flue. This flue



LOCOMOTIVE FLUE BLOWER.

blower drives everything out at the smoke box end. The automatic anti-dust flue blower makes no extravagant claim to being able to blow out a flue in which coal, ashes, water, etc., have become cemented there through whole trips of neglect. The flue blower is an appliance which practically blocks up one end of a flue for the time being and blows all the matter right through the flue. If you use this flue blower decently it will treat you all right.

**WANTED**

Detail Mechanical Draughtsmen, men familiar with locomotive and car construction preferred. Apply, giving references, experience and salary expected, to Box No. 40, care Railway and Locomotive Engineering.

**CONTENTS**

	PAGE.
*Zambesi River Bridge.....	1
British Notes and News, A. F. Sinclair.....	4
*Patent Office Department.....	6
*Object Lesson of the Chair, A. O. Brookside	8
General Correspondence.....	9
Wrong Statement vs. Accuracy.....	14
Steel Rails.....	15
Question and Answers.....	23
Drill Press Hints.....	24
*Air Brake Department.....	25
*Our Correspondence School.....	21
*Piston Rod Puller.....	27
*Electrical Rod Puller.....	28
*Motive Power of the Lchigh, Angus Sinclair.	30
Personals.....	33
Railway Telephones.....	40
Metal Ties.....	47
Locomotive Superheaters.....	41
*Dahl Automatic Drill Grinder.....	43
*Electric Pump Plant.....	44
*Handy Pneumatic Drill.....	48
Railway Extension in Canada.....	48
Locomotives:	
*Simple 4-6-2 Central of Georgia.....	7
*Caladonians.....	11
*2-8-0, Oil Burner for the Mexican Central.	35
*Interesting Relic.....	46
Cars:	
*Hospital Car on the Erie.....	13
*Bogie Well Wagon.....	38
Editorials:	
Our European Edition.....	16
The Risk of the Trade.....	16
So-called Train Protection.....	17
Needs of the Patent Office.....	18
Leakage of Slide Valves.....	18
Time Table Advertising.....	19
Red Snow.....	19

# Railway and Locomotive Engineering

Copyright by Angus Sinclair Co.—1907

## A Practical Journal of Railway Motive Power and Rolling Stock

Vol. XX.

136 Liberty Street, New York, February, 1907

No 2.

### Niagara Canyon Trestle.

The railway bridge which forms the subject of our frontispiece illustration

Railway over what is called the Niagara Canyon in Vancouver Island, British Columbia. It is situated about

per cent. grade and a ten degree curve. It is 585 ft. long and the height of the wooden structure is 120 ft. The trestle,



NIAGARA CANYON TRESTLE ON THE ESQUIMALT & NANAIMO RAILWAY IN B. C.

this month is the wooden trestle which carries the Esquimalt and Nanaimo fourteen miles from the city of Victoria. The bridge is built on a one ft. high, which is held at the toe or most

advanced part of the curve, by a crib 75 ft. high. There is a waterway under the trestle consisting of a rock tunnel 6 x 4 ft. by 400 ft. long. The height from water level to rail top is about 195 feet.

The bridge contains approximately about three-quarters of a million feet of timber. This is board measure, and in this method of computation one foot board measure means a square foot of timber one inch thick; therefore 12 ft. board measure would equal one cubic foot of timber. There is, therefore, 62,500 cubic feet of timber in the structure. If this amount of timber was laid out as a solid pile without air spaces between the beams it would cover the area inclosed between the four bases on the "diamond" field, to a depth of more than 7½ ft. If layed out as a continuous plank board walk one foot wide and one inch thick it would reach more than 140 miles.

The use of timber for railroad bridges has steadily declined not only on account of the rise of the iron industry since railroads began to be built and the production of structural shapes but because of the greater length of span which can be bridged by the use of metal, and its greater strength, but also on account of the safer and more permanent character of a modern steel bridge. Mr. T. C. Clark, in an article written about 1888, estimates that there were in that year about 3,213 miles of bridges of all kinds in the United States and .01

struction intended to span a stream or small ravine, and from this simple beginning the art of bridge-building has grown in boldness of design and skill in the adaptation of material to the present day. In crossing streams where the distance from bank to bank was too great to be covered by one beam, stone piers were resorted to which carried the ends of the beams and thus united into one structure a series of what were in reality primitive single bridges, each distinct from the other, yet forming one continuous roadway.

The trestle-bridge is in this sense an adaptation of the primitive form, as each bent takes the place of a stone pier for the support of the horizontal beams on top. Modern trestle-bridges are braced in the direction of their length from bent to bent so that, in a sense, they form one structure, though each row of upright timbers carries the load in a perpendicular direction. The bents are made wide at the bottom, when the trestle is of sufficient height to require it, in order to provide lateral stiffness to the whole, and to resist wind pressure.

Historians tell us that the Pons Sublicius was the first bridge ever built over the Tiber at Rome. This bridge was constructed of timber in the reign of Ancus Martius and was entirely without bolts or ties. It was made in this way so that it could readily be taken down. This feature was, no doubt, deemed to be a military ne-

stirring and dramatic incident, immortalized by Lord Macaulay in the first of his Lays of Ancient Rome, sets forth "how well Horatius kept the bridge in the brave days of old."

### Steam Boilers.

From "Development of the Locomotive Engine," by Angus Sinclair.

The following are the principal requisites in a well designed boiler: 1. To secure complete combustion of the fuel, without permitting dilution of the products of combustion by excess of air. 2. To secure as high temperature of furnace

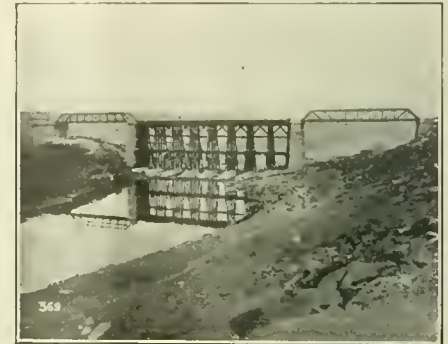

### TEMPORARY REPAIRS WITH TRESTLE.

as possible. 3. To so arrange heating surfaces, that without checking draft the available heat shall be most completely taken up and utilized. 4. To make the form of boiler such that it shall be constructed without mechanical difficulty or excessive expense. 5. To give it such form that it shall be durable under the action of the hot gases and of the corroding elements of the atmosphere. 6. To make every part accessible for cleaning and repairs. 7. To make every part as nearly as possible uniform in strength and in liability to loss of strength by wear and tear, so that the boiler when old shall not be rendered useless by local defects. 8. To adopt a reasonably high "factor of safety" in proportioning. 9. To provide efficient safety-valves, steam gauges and appurtenances. 10. To secure intelligent and very careful management.

### BOILER EXPLOSIONS.

For many years after steam boilers came into use violent accidents by rupture and explosion were so common that a belief prevailed that some mysterious agencies were at work inside boilers, which no degree of strength could resist. Increase of knowledge concerning boiler construction has eliminated from engineering minds all theories about mysterious causes for boiler explosions. All men familiar with the design, construction and care of steam boilers are unanimous in the belief that explosions happen only when some part of the boiler is too weak to resist the steam pressure within. The weakness may arise from faulty design, deterioration, want of care, or by reckless prac-

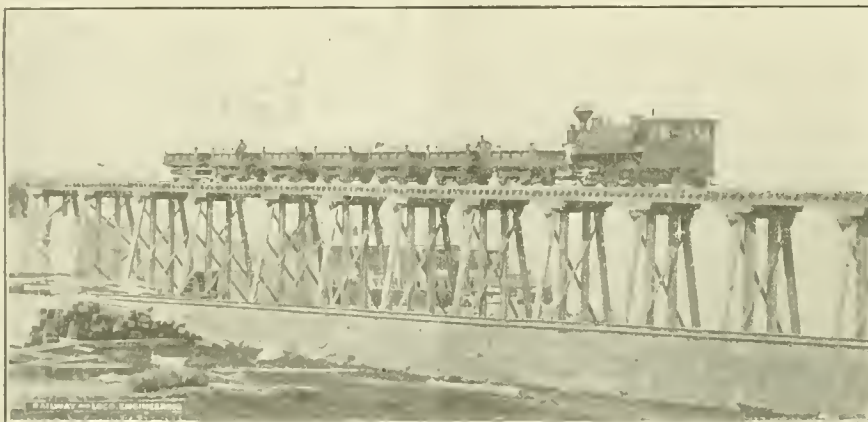

TYPICAL TRESTLE BRIDGE USED IN RAILROAD CONSTRUCTION.

these about 2,127 miles were made up of trestles. Speaking on this subject he says, "The wooden bridge and the wooden trestle are purely American products, although they were invented by Leonardo da Vinci in the sixteenth century."

A tree fallen across a stream was no doubt the earliest suggestion of a bridge offered by Nature and from this the roughly hewed beam or plank with ends resting on either bank was probably the origin of all forms of con-

struction at the time, for on a later day the Romans hastily threw down the bridge over which the hostile army of Lars Porsena was about to enter the city, and they accomplished the complete destruction of the bridge in the short time that Horatius and two Roman warriors were able to check the advance of the Etruscan host by fighting in single combat with three antagonists at a time where they could not be surrounded in the narrow entrance to the bridge. The story of this



trices on the part of those in charge. No matter how the weakness may arise, it is agreed that accidents happen only through steam pressure being too great for the plates provided to hold it inside.

#### SURVIVAL OF THE FITTEST.

There is a great variety of steam boilers in use, and a vast variety of forms have been tried and abandoned as unsuitable. The best known existing forms of steam boilers have held their own through a prolonged process of natural selection, and have been adopted because they were the fittest for their purpose.

#### GLOBULAR BOILERS.

The globular boiler was the first form employed to generate steam much above the atmospheric pressure, and was no doubt chosen because it is the strongest natural form for resisting pressure. With a globular vessel pressure within puts equal strains on the whole of the surface, and there is no tendency to distort the contour of the surface. Soap bubbles, toy balloons and numerous other objects supply illustrations of how strong the globular form is to resist inside pressure.

The experiments made with steam engines and boilers during what has been called the "speculative era," of the steam engine, were all carried out by philosophers and scientists, so it was natural that they should cling to the strongest theoretical forms in designing boilers. The globular form of boiler was the favorite form in use until the improvement of the steam engine fell into the hands of practical mechanics. The first form of furnace used was a plain hearth made of brick or other refractory material, and the first important improvement effected was the raising of the fire and placing it upon grates, which permitted the air necessary for combustion to enter beneath the fire. This invention was the work of a French scientist.

Although the solid hearth was early abandoned by steam makers, owing to the difficulty of supplying the necessary air to the fuel, its use was several times revived by inventors of smoke preventing furnaces, and it is now employed largely in metallurgical operations.

#### THE CYLINDRICAL BOILER.

The principal shortcoming that a globular form of steam boiler suffers from is that it provides very little heating surface. When practical mechanics began to work out the necessary appurtenances of a steam engine that would do the work more cheaply than other forms of power, they quickly adopted the cylindrical form of boiler, which is strong, of simple shape and provides a large surface for the fire gases to act upon to heat the water within.

In connection with the cylindrical boiler

the oblong furnace with a bridge in front came into use. The bridge was not applied for many years after the oblong furnace was introduced, but the combination is nearly as old as the modern steam engine. The combined arrangement is that most commonly employed. With slight modifications this furnace is almost universally used except for locomotives, and it was the first furnace applied to the pioneer locomotives. With skillful fir-

dical boiler, which had the furnace outside and had merely the bottom plates for heating surface, was the Cornish boiler, which had a large single flue through the center of the water space and had the furnace at one end of this flue. The next step in boiler development was to put in a return flue, so that the fire gases passed twice through the boiler. The first practical locomotive, or at least the first locomotive to perform everyday work of haul-



OLDEST FORM OF BRIDGE IN THE WORLD, A FALLEN TREE ACROSS A STREAM.

ing, and with means provided for admitting air over the fire, this furnace can be made to burn coal as economically and as free from smoke as any ever invented. Another good thing about this furnace is, that there is nothing in its construction which a common fireman cannot understand.

#### THE CORNISH BOILER.

An improvement on the plain cylin-

ing cars, had a boiler of this kind. It was built by William Hedley in 1813.

An improvement on a single large return flue was two smaller ones, which gave much more heating surface for the space occupied. This line of development gradually led to the modern multi-tubular boiler. When a boiler flue is smaller than 3 inches diameter it is usually called a "tube." This brings us to the modern locomotive boiler.

## DEVELOPMENT OF THE LOCOMOTIVE BOILER.

Those pioneer engineers who gave to the world the high speed locomotive with all the essential parts complete, performed a very difficult problem when they designed a suitable boiler. Before the work was done the difficulties seemed insurmountable. Two conflicting elements had to be harmonized. The problem called for the lightest form of boiler that had ever been used, and at the same time it must generate steam ten times faster than the boilers most commonly in service.

American inventors, whose genius had been stimulated by the demand for fast steaming boilers for river steamers, had made the engineering world familiar with various forms of multitubular and water tube boilers, but neither of these seemed suitable for locomotives, as they required a built-up furnace. To use an internal furnace in a large flue and then small return tubes above, called for a larger boiler than was considered permissible with a locomotive. A firebox seems a simple expedient after we have seen it applied, but it was a tremendously difficult undertaking for those who applied it for the first time.

## INVENTION OF THE FIREBOX.

Various inventors and engineers had proposed employing a firebox in combination with the multitubular boiler for locomotives, but there were difficulties of construction to be overcome that the pioneer boiler makers were slow to overcome. The first engineer to apply to practical use the combination of a multitubular boiler and firebox was Mr. Marc Seguin, of the St. Etienne Railway, of France. In the beginning of 1829 he changed the boilers of two locomotives bought from the Stephenson's, and built them in his own way. In this the water did not surround the firebox. Referring to the engraving it will be seen that firebox was a detached chamber, so secured that the fire gases passed directly into the boiler tubes. A fatal objection to this form of firebox was that the material soon burned out. When it was lined with brick the rattling of the engine quickly shook the structure apart.

Detached brick fireboxes have been experimented with a great deal at various times during the last sixty years. Not a few modern engineers believe that a firebox made of firebrick would be more economical than the common form, which has plates surrounded by water, because a higher furnace temperature would be maintained. The Verderer boiler, which was tried in Germany some years ago, had a brick-lined firebox. Apart from the tendency of this form of firebox to shake to pieces, a still more serious difficulty arose against its use. The boiler tubes received the fire gases at such a high temperature that no means could be devised to keep them from leaking.

## THE MODERN FIREBOX.

Seguin's experiment with the detached firebox with solid sides was a highly important step forward, but the prototype of the modern firebox appeared in Stephenson's "Rocket," which was built in 1829. The furnace is a double box, one inside the other, with a water space separating the two shells. It was secured to the back boiler-head, and had circulating pipes on each side to keep the water moving between the body of the boiler and the firebox. Within two years after this firebox was put into use the locomotive firebox reached its present shape in small forms of engines. Very few locomotives were afterwards built without fireboxes.

## Mexican Central Oil Burner.

The American Locomotive Company's shops at Paterson, N. J., formerly called the Cooke Locomotive Works, have recently turned out some consolidation engines for the Mexican Central Railroad. These 2-8-0 freighters burn crude oil and are altogether very powerful machines, and with the large tapering smoke stack, steel cab, and large windows, present what may be called a very business-like appearance. It so happened that last month the description of these engines became involved, in our printing office, with that of a 4-6-0 compound engine for the Italian Government. The illustrations of this Mexican Central oil burner of the 2-8-0 type are to be found on pages 35 and 36

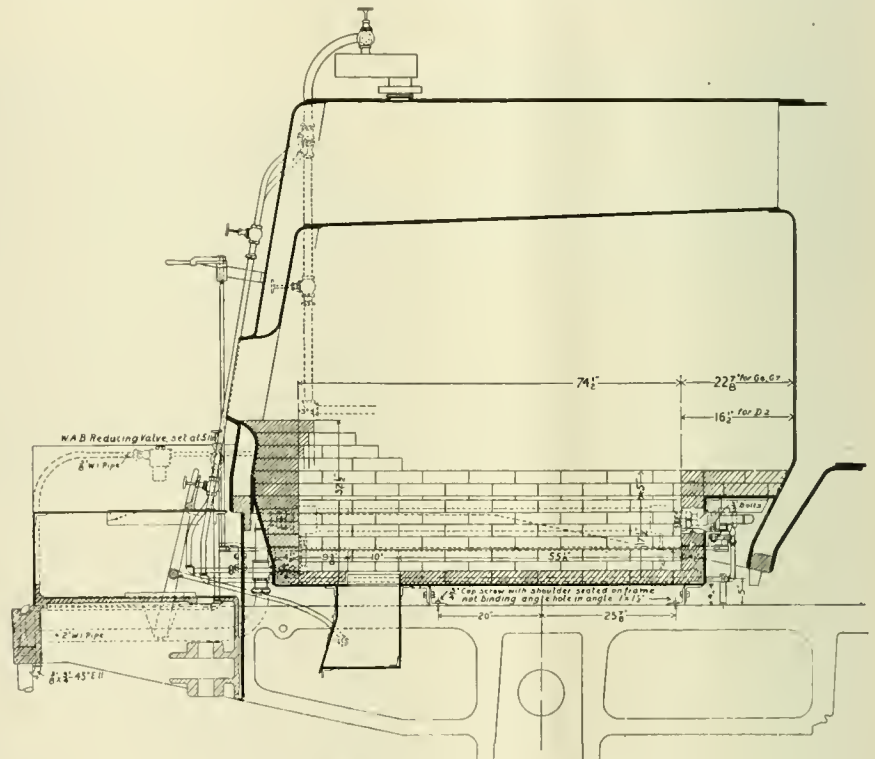

FIREBOX OF MEXICAN CENTRAL OIL BURNER.

No invention connected with improved methods of transportation received such general and cordial adoption as the locomotive firebox. Yet, strange to say, there is no part of the locomotive except the link motion, that has been the object of so much fault-finding. It is reputed to be the worst kind of form to withstand pressure successfully, it does not lend itself conveniently to the putting in of a large enough grate, it is awkward to make and hard to maintain in good order, while its perpendicular sides are a vicious form of heating surface. Substitutes without number have been offered, and the highest engineering endorsements testified that they were likely to be much superior to the firebox, yet somehow this ridiculous paradox on engineering perfection would not be suppressed, and it continues to hold its own, while all its rivals slip one after another into quiet oblivion.

of our January issue, and the following is the description of the engine:

The cylinders are simple, being 21 x 26 ins., with piston valves. The driving wheels are 55 ins. in diameter and with a boiler pressure of 200 lbs. to the square inch, the calculated tractive effort is 35,440 lbs., and with 180,000 lbs. on the drivers the ratio of tractive effort to adhesive weight is as 1 to 5, very nearly. This makes the engine one with little tendency to slip. The valves are inside admission, actuated by the Stephenson link motion. They have a travel of 5½ ins., lead 1-32 of an inch, lap ¼ of an inch and the exhaust cavity is made line and line with the steam ports.

The driving wheels are so arranged that the third pair are the main drivers. All the wheels are flanged, and the equalization is arranged so that the pony wheels of the front truck are equalized with the

two leading drivers and the main and rear wheels are equalized together. The engine is supplied with the water brake for use on heavy grades.

The boiler is of the straight top wide firebox type, 78 ins. diameter at the smoke box end, with firebox over the frames. The tubes are 379 in number, 2 ins. outside diameter and 14 ft.  $7\frac{3}{4}$  ins. long. These tubes give a heating surface of 2,886.3 sq. ft., the firebox gives 124 sq. ft., making in all 3,010.3 sq. ft. of heating surface, which is equal to a square a side of which is a little less than 55 ft. long. The firebox is 74 ins. deep at the front and 60 ins. deep at the back. The box is  $97\frac{1}{2}$  ins. long and  $66\frac{1}{4}$  ins. wide, with a grate area of 45.2 ft. This gives a ratio of grate area to heating surface as 1 is to 66.5. In speaking of grate area here, it must be remembered that there is actually no grate used, as this engine burns oil. The water spaces about the firebox are  $4\frac{1}{2}$  ins. front and back and 7 ins. at the sides.

The fuel oil reservoir is of course carried in the tender and 3,000 U. S. gallons of crude oil are provided for. The oil flows by gravity to the burner, passing through a hose connection between the engine and tender. In order to accelerate the flow of oil a connection made with a reducing valve on the brake system feeds air at a pressure of 5 lbs. on top of the oil in the reservoir, which is of course air tight. The air does not mix with the oil, but its pressure simply serves to hasten its rate of flow to the burners. An arrangement for heating the oil before it leaves the tender is used, in the shape of a coil of steam pipe placed in the lower and forward part of the oil reservoir on the tender. The oil is therefore always warm when steam is turned on, but that which flows to the burner is necessarily hottest as it passes over and around the heater coils as it flows to the hose connection and on to the burner.

The engine has no need of an ash pan in the ordinary sense of the word, but what corresponds to the ash pan is lined with firebrick which is stepped up at the back, and as the burners are placed at the front the flame flows back and the heated gases thus pass back through the firebox again on their way to the flues. The ash pan, however, has a damper near the back end. The burners are placed in a recess in the ash pan just back of the front portion of the mud ring and are so made that the oil is driven out, under the 5 lb. air pressure of which we spoke, through an opening in the burner  $3 \times \frac{1}{2}$  ins. This rectangular stream of oil moving comparatively slowly would however not travel very far after leaving the burner, but the stream of oil is caught upon a flat, thin jet of steam blown out of an aperture  $3\frac{1}{2} \times 1-32$  ins., placed immediately below it. The rapidly moving steam, so to speak, carries the oil along on a flat

jet like a spreadout fan and breaks up the oil stream, separates it, and sprays its particles so that each one can be reached by air and burned. The result is a powerful flame reaching back a considerable distance and with a slight upward curve due to the heat of combustion.

As to the efficiency of oil as compared with coal, it is pretty well established that the British Thermal Units in petroleum will vary from 17,000 to 20,000, whereas good bituminous coal has about from 13,000 to 14,000 B. T. U. per pound. Mr. George R. Henderson in his book on Cost of Locomotive Operation makes some interesting observations on the subject. He says: "With a tractive effort of 20,000 lbs. and a speed of 25 miles per hour, we would burn 8,000 lbs. of coal and only 4,000 lbs. of oil, or one-half as much. At 15 miles per hour, however, and the same tractive force, we would use 3,000 lbs. of



DOING WELL, THANK YOU.

coal and 2,400 lbs. of oil an hour, four-fifths as much due to the greater evaporative efficiency of coal at low rates of combustion." Oil fuel is from 25 to 30 per cent more efficient than coal as a heat producer, weight for weight.

The tender of that engine holds as we have said 3,000 gallons of fuel oil, and it carries 6,000 U. S. gallons of water. It weighs when empty 66,000 lbs. The weight of the engine alone is 199,000 lbs. Some of the principal dimensions are as follows:

Wheel Base—Rigid, 15 ft. 6 ins.; engine, 24 ft.; engine and tender, 57 ft. 11 ins.; ash pan, sheet steel, lined with fire brick.  
 Axles—Driving journals, main,  $9 \times 11\frac{7}{8}$  ins., others,  $9 \times 11\frac{3}{4}$  ins.; engine, truck journals,  $6 \times 11\frac{7}{8}$  ins.; tender journals,  $5\frac{1}{2} \times 10$  ins.  
 Boiler—Thickness of ring, first  $\frac{3}{4}$  in., second  $\frac{13}{16}$  in.; throat,  $\frac{3}{4}$  in.; dome,  $\frac{9}{16}$  in.; front tube,  $\frac{9}{16}$  in.; roof,  $\frac{9}{16}$  in.; side,  $\frac{9}{16}$  in.; back head,  $\frac{1}{2}$  in.  
 Fire Box—Thickness of crown,  $\frac{3}{8}$  ins.; tube,  $\frac{9}{16}$  ins.; side,  $\frac{3}{8}$  ins.; back,  $\frac{3}{8}$  ins.  
 Smoke Stack—Diameter at choke, 20 in. choke.  
 Tender—Wheel base, 21 ft. 7 ins.; frame, 9 in. steel channel.

### Haste to Save the Work Train.

There was a rush job came into the headquarters shop of a large railroad not long ago, and it was handled promptly and in good style. It seems that there was a construction train working not far from headquarters, and the engine on the train was kept going pretty steadily and had to syphon up water wherever it could be got. This was from a running stream here or a stagnant pool there, and the water-taking equipment consisted of a syphon and a long rubber hose, which was kept from collapsing by a coiled wire spring inside the hose, which extended the full length of the hose, perhaps twenty feet in all.

The engineer of the work train engine requested a new hose 30 ft. long, as the old one began to show signs of wear, had suddenly failed, and the requisition was O. K.'d and sent to the stores department. They tried to procure it from an outside firm and sat down and waited. In the meantime the train was waiting and a new one had to be provided or the train cancelled. Then the stores department telephoned everybody, but could not get what they wanted. Everything pointed to a shut-down for the work train, but the storekeeper knew that the general foreman was a resourceful man, so he ran down to the shop with an order to fit up the hose, just as if the work had been done in the shop every day.

As soon as the general foreman got the order he pulled out a pencil and pad of paper and made a few quick figures, and said he'd try it. He called the machine shop foreman and told him how the work train was stuck and the stores department were very hard up against a stone wall. The storekeeper, looking calm and pleasant, as if it was all plain sailing, did not have the effect of fooling the general foreman for a moment. He made the machine shop foreman begin winding wire tight on a  $1\frac{1}{2}$ -inch bar about 10 feet long, pretty much the full extent of the lathe they had at their disposal, and he went over to the boss pipe fitter. He there ordered two lengths of  $1\frac{1}{4}$ -inch pipe, 16 feet long, and where the pipe lengths joined a plug was driven inside and riveted in place so that the outside had a smooth, unbroken surface for its entire length. A  $\frac{3}{8}$ -inch hole was drilled through one end of this piece of piping.

When the piping was ready the bar in the lathe was full of tight, close-wound spring wire, and they took it out of the lathe and knocked the bar out of it, and it sprung up to about 3 inches diameter. It was then laid on the floor and stretched by hand to about 30 feet long. Then the  $1\frac{1}{4}$ -inch piping was run through the loose wire coil and the end of the coil made fast in the  $\frac{3}{8}$ -inch hole, which had been drilled in the end of the pipe.

The loose end of the coil was then grasped by hand and held fast while a man with a large pipe tongs on the loose end of the piping turned it round and round and round. While he was doing this the other two men, assisted by the machine shop foreman, and occasionally helped by the general foreman, kept the tightening coils of the wire about the proper distance apart, so as to spread out about 30 feet, and in due time the wire was coiled up on the long piece of piping and it was a go.

Then they pushed the long piece of piping with the coiled wire upon it into

**Private Car for the Western Union.**

A very good example of the kind of new work of a high order which can be turned out by the Hicks Locomotive and Car Works, of Chicago, may be found in the private car recently built for Mr. Thomas P. Cooke, general superintendent of the Western Union Telegraph Company. The principal dimensions are as follows: The length of the car over sills is 68 feet, width 9 feet 8 inches; width over all 10 feet 0½ inches; height from sill to plate, 6 feet 8½ inches, and height over all 13 feet 11 inches.

The interior arrangement consists of an

and contains one section of upper and lower berths, wardrobe, hopper, white metal washstand with hot and cold water and water cooler.

The private room is 9 feet long by 7 feet wide, and contains a 4-foot brass bed, made of square tubing, with two drawers underneath for bedding and personal effects, and provides sufficient space for a steamer trunk. There are also wardrobe, hopper, white metal washstand, with hot and cold water and water cooler, and a commodious dresser with drawers and plate glass mirror.

The dining room is provided with an



PRIVATE CAR "CHICAGO," BUILT BY THE HICKS LOCOMOTIVE AND CAR WORKS.

the hose and cut the wire at the ¾-inch hole and the wire sprung out, expecting to go to 3 inches diameter, but found the hose was 2½-inch bore, so it stayed that size and filled the hose and stood ready to guarantee that the hose would not collapse while it was alive and well. The piece of piping was backed out, the protruding ends of the wire were cut off and the hose delivered for shipment.

Then the hose was shipped to the work

11-foot observation room with two sections adjoining, one stateroom, one private room, a 13-foot dining room, section for attendants, and kitchen. The car throughout, excepting the kitchen and section for attendants, is in quarter-sawn oak, of carefully selected grain, with neat single line inlaid, and with rubbed flat finish. The design of the interior and its flush finish is intended to minimize the amount of space where dust may lodge.

The observation room has a desk and

extension table, an extension sofa, making a lower berth. The sofa and dining room chairs are upholstered in olive and buffed leather. The dining room also contains two desks with bookcases above. One of these is a typewriter desk for the use of Mr. Cooke's private secretary. The toilet rooms are commodious and complete.

The section for the attendants and the kitchen are finished in plain oak, the kitchen being completely furnished, with

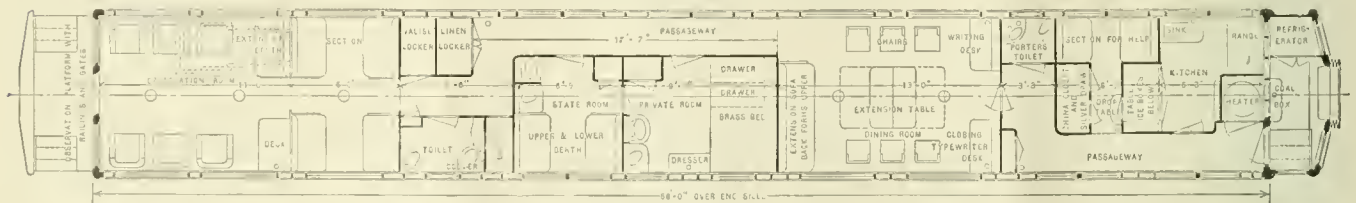

PLAN OF THE WESTERN UNION PRIVATE CAR "CHICAGO."

tram engine in hot haste. Then those who were in the game knew that the general foreman was a man of action and had got there qualities, and the storekeeper who had been up against a stone wall did not fail to show his appreciation of the whole thing by heaving a sigh of relief alone in his own office with the door shut tight.

No human head was stamped on coins until after the death of Alexander the Great. Previous to that time the images used were deities.

an extension seat forming a lower berth when extended for emergency use. Window openings in the observation room extend to the letter board without upper or Gothic sash, in order to permit inspection of telegraph poles and wires, while the car is running. The end windows and doors of the observation room are also large and low cut for inspection purposes.

The upholstery in observation room and adjoining section is Olize Frieze plush of a neat star pattern. The stateroom is also upholstered in the same material

Stearns steel range, sink and table, copper covered; ice box, dish racks, provision closets, etc. The refrigerator is placed in the vestibule at the kitchen end, and extends from the floor to the hood, and has a very large capacity for ice, and is lined with porcelain.

The car contains an unusually large amount of locker and storage space for ice and provisions, and the arrangement is said to be remarkably convenient. The heater is a Frumveller double coil, in connection with Safety Car Heating Company's system of direct steam. The

car is lighted with Pintsch gas throughout, and carries large storage tanks for gas. The trucks under this car are of the Hicks standard construction 6-wheel trucks, with 30-inch Paige steel tired wheels; journals, 5 by 9 inches, side bearings, automatic frictionless rollers; brakes, Westinghouse high speed; platform and draw gear, National twin spring. The observation platform is extra wide, and is provided with trap doors and covered with inlaid rubber tiling. The hand rails are wrought iron with brass caps. Altogether, comfort and elegance have been secured for the use and pleasure of the occupants. The car is in every way a good specimen of the modern private car, and forms either the living apartment or the office of a busy man of affairs, as occasion requires.

**Jim Skeevers and a Gentleman.**

Skeevers was "acting master mechanic" once while the real article went "down East," got married, and honeymooned around a while for all the world like a common engineer or a human being.

Skeevers didn't make any startling changes, but while he sat in the office he was boss, all the same, and he put the knife into every sore caused by friction between engineers and firemen.

They couldn't any of 'em shut Skinny

saw, for the first time, a middle-aged scrapheap on the Coalville branch, and Skeevers made a note in his book that the "38" was the dirtiest engine he ever saw."

When he got back home he wrote a letter to the engineer, saying that he was ashamed of the engine and of him; that whoever the fireman was, he, the engineer, was responsible for him, and that if the engine wasn't at once put into decent condition the engineer would hear something drop.

In a couple of days a reply came in, couched in very dignified language; there was no excuse for the dirt, no promise to remove it, no word about the fireman, but a protest against the summary way that Skeevers wrote.

"I want you, sir, to distinctly understand that I am a gentleman and shall insist on being treated as such," concluded the epistle of the offended "plug-puller" of the branch run.

Skeevers sent him a pass by the first train—and also a man to relieve him.

"Yes, sir."

"I'm glad to know that; I got the impression from a letter you wrote me that you were down on the pay-rolls as a gentleman. They may need some of them



INTERIOR OF OBSERVATION ROOM.



DINING ROOM WITH TABLE MOVED TO ONE SIDE.

Skeevers' eye with a five-act story—Skinny knew all the stories by heart, and the men, too.

Skeevers went over the road with the officials on a tour of inspection once, and

The next day he climbed the stairs to Skeevers' office with three gauges of indignation on. Skeevers knew he was coming, and was busy writing.

"Is Mr. Skeevers here?" he asked, as he leaned his arm on the railing.

"What do you want to see him about?" asked a fresh young clerk.

"I want to see the master mechanic of this here road," said the gentleman from Coalville.

"I am that person," said Skeevers, quiet like. "May I ask who you are?"

"I am the engineer of the '38.'"

"Oh, yes; let's see, how long have you been running an engine here, sir?"

"Six years, and I"—

"Never mind, now, but don't you draw

pay from this company for another position?"

"No, sir!"

"Just hired for an engineer and paid for that and nothing else?"

in other departments, but I want engineers, firemen and mechanics; I wouldn't give the best gentleman in America \$20 a month for my part of the work.

"I understand, sir, that you are connected with some of the first families here, but that cuts no figure with me. After working hours you may lead the german at the Governor's ball if you want to, for all I care; but while on duty here you are in charge of a locomotive, and are responsible for it to me, and I to the management. I don't care a continental cuss whether you were born in the White House or the gutter, who you married or what church you belong to. It cuts no figure here, as I remarked before.

"I do care what kind of an engineer you are, though, and you can't be any better engineer because you belong to the Masons, the Episcopal Church, the Greenback party or the Holy Rollers. Marrying into the first families won't help you, and being born in a hovel won't hurt you—as an engineer.

"It's an engineer's duty to see that his engine is kept reasonably tidy; the fireman should do most of this work under your direction, but you are as responsible for that as you are for the packing of the valve-stems.

"Now, sir, this road wants good engineers, and gentlemen would be a drug on the market. If you want to try running the '38'—as an engineer, mind you—I am

willing. You go right ahead and marry a wench or a Pawnee squaw, if you want to, and tell 'em all it's none of my business; but if you don't clean up that engine before Saturday night, I will fire you off the face of the earth and hire an engineer.

"Give Mr. Pangborn a pass to Coalville, James. Good-day, sir."

"That's what I call a dry roast," said the chief clerk, as the gentleman runner shut the hall door at the foot of the stairs.

"That's what my old fireman calls an object lesson, illustrated," said Skeevers, "and, whatever it is, I know that Pangborn sees something in a different light than he did, and he won't forget it, eyether."

#### Mummied Engines Not Wanted.

The Orange was one of the old six-foot gauge engines, and when the change was made to standard gauge she was removed from service. After lying on the

#### Passenger 4-4-0 for Japan.

An order of three 8-wheel, 2-cylinder compound engines has recently been completed at the Pittsburgh works of the American Locomotive Company for the Kansei Railway of Japan. In working order the engines have a total weight of 86,000 lbs., of which 52,400 lbs. is on the driving wheels. The high pressure cylinders are 17 ins. in diameter by 24 ins. stroke, and the low pressure are 25 ins. in diameter with the same length of stroke.

With driving wheels 62 ins. in diameter, and a boiler pressure of 180 lbs., the engines have a calculated tractive power, working compound, of 14,350 lbs. The factor of adhesion, which is got by dividing the weight on the driving wheels by the tractive effort, is in this case 3.05. The slide valves are of the balanced Richardson type. The high pressure having a travel of 5 ins., and the low pressure

so that the depth of the box is greater at the front by that amount.

The tender has a 7-in. channel frame and the tank is of the ordinary level-top, U-shaped kind, holding 2,400 U. S. gallons of water and carrying 5 tons of coal.

Some of the principal ratios and dimensions of the design are as follows:

Total weight	
Total heating surface	= 82.3
Volume of 2 equivalent simple cylinders	= 5.3
Total heating surface	
Volume of equivalent simple cylinders	= 200
Grate area	
Cylinder volume	= 2.55
Total weight	= 6
Tractive effort	
T. E. x diameter of drivers	= 853
Heating surface	
Total heating surface	= 79
Grate area	
Total firebox heating surface	= .077
Total heating surface	
Weight on drivers	= 50.2
Total heating surface	



STANDARD 4-4-0 ENGINE FOR THE KANSEI RAILWAY IN JAPAN.

cripple track and in the shop for some time she was finally placed in a glass house, or case, in the east end of the Susquehanna shop as a sort of a curiosity of the early days of Erie's history.

A former president of the company making the rounds of the shop one day saw this engine in the glass case. "What's that?" he asked.

"That is one of the first engines used on the Erie road, and the boys rigged up that case so as to protect the old curiosity," answered one of the shop men.

"This shop is no museum," remarked the president. "Send her to the scrap heap." So to the scrap heap she went and that was the end of the Orange. This statement is borne out by a number of the oldtimers, so that there is now no doubt as to what became of the Orange.—Erie Ry. Employees' Magazine. [A weak point about this yarn is that it is not true, but in all other respects it is an excellent story.—Ed.]

6 ins. The high pressure valve is set with  $\frac{7}{8}$ -in. lap and  $\frac{1}{16}$ -in. lead in full gear. The low pressure has  $\frac{13}{16}$ -in. lap and  $\frac{3}{32}$ -in. lead. The exhaust clearance is  $\frac{3}{16}$  ins. The driving springs are underhung.

The boiler is of the straight-top, radially stayed type, it is 54 ins. outside diameter at the front end, and is fitted with copper fire box and brass tubes. There are 228 tubes in the boiler, each  $1\frac{3}{4}$  ins. in diameter; the length of the tubes is 9 ft. 4 ins. The fire box is 66 ins. long and  $28\frac{7}{8}$  ins. wide, and has a grate area of  $13\frac{3}{4}$  square feet. The total heating surface of the boiler is 1,044 square feet, of which the tubes contribute 963 square feet and the fire box 81. The roof sheet is level, while there is a slight slope to the crown sheet toward the front. The fire box is deep and is placed between the frames in the manner common to many 8-wheel engines. The mud ring, however, slopes  $9\frac{1}{2}$  ins. to the front,

Track Gauge—3 ft. 6 ins.

Wheel Base—Driving, 7 ft. 6 ins.; total 20 ft.; total, engine and tender 38 ft.  $5\frac{1}{2}$  ins.

Weight, in Working Order—86,000, engine and tender, 139,900.

Grate Area—13.25 ins.

Boiler—Fuel, soft coal.

Firebox—Thickness of crown  $\frac{1}{2}$  in.; tubes,  $\frac{7}{8}$  in. and  $\frac{9}{16}$  in.; sides,  $\frac{9}{16}$  in.; back,  $\frac{9}{16}$  in.; water space, front,  $3\frac{5}{16}$  ins.; sides,  $2\frac{1}{2}$  ins.; back, 3 to 4 ins.

Crown Staying—1 in. radial.

Tubes—Material brass; wire gauge No. 13.

Engine Truck—Four-wheel swinging.

#### Awful Trouble.

"More trouble," sighed McNutty, putting on his coat. "If it ain't one thing it's another!"

"What's the matter, now?" queried his wife.

"More labor troubles," answered McNutty.

"Not another lock-out, I hope?" said she.

"No; it's worse than that," answered the poor, dejected fellow, picking up his dinner pail. "The boss has yielded, and I've got to go to work again!"

# General Correspondence.

## Estimate of Heroism.

Editor:

Recently I have seen and read in the technical, as well as in the newspapers, efforts to decry the heroism of locomotive engineers who stand at their posts regardless of danger. I want to say just a few words in reference to this. First, if there are yellow streaks in a fellow he doesn't usually last long enough in the service to become an engineer, hence I believe I can say with truth that our calling is singularly blessed with a very small percentage of cowards.

When a young fellow who has in him the elements of character that go to make one of "nature's engineers" first takes his place on the foot plate as a fireman an idea of what he ought to become and what he ought to be begins to take form in his mind, and this ideal, and the thoughts and habits growing out of it, assumes more and more definite form as he advances in experience until when he becomes an engineer in name he has also become one by nature. In trying moments he does certain things quickly, calmly and in an orderly way, heedless, perhaps oblivious, of personal danger, because greater things—things he has trained himself to consider before self—occupy his mind. In his "mind's eye" he has dealt with every emergency, and whatever occurs the engineer, if he be one of "nature's own," if he be a hero in the true sense of the word, will do what is to be done naturally and easily, for his every motion, every manipulation of the controlling mechanism of the engine at his command is mapped out in his mind beforehand. He does not act for plaudits, for glory or presents. A man face to face with danger and possibly death does not think much of these, for they ill become a man maimed or dead. But if Duty stands before the mind with a nearness that shuts out all else, then the man to whom she thus appeals will do his duty naturally, easily and fearlessly.

While much is said through the press and otherwise belittling the heroic in the engineer's life and makeup, I am not disposed to lend such efforts any sympathy. While the heroism of the ideal engineer has no kinship with that usually exhibited in dime novels and newspaper stories, and while it may not have underlying it angelic unselfishness—an entire disregard of personal safety and well-being—it is none the less real heroism and none the less worthy of emulation.

The simple truth is, we take up the work because we must do something to make a living and because we would rather make a living at it than anything else that is available to us. Then after we are in the service we learn that certain duties devolve upon us, and these duties are set forth in part in the books of rules which we receive when entering the service, and there are others devolving upon us by unwritten laws. For instance, we know that we are under a greater obligation to protect life than to protect property and no engineer worthy the name would hesitate to incur risk of personal injury to save a train load of people, whose lives have been, as it were, committed to him. To sacrifice the lesser for the greater interests, to risk injury or one life to

ings are used to lessen the inconvenience that might be caused when necessary to open the front end. I understand the L. S. & M. Ry. have tried and abandoned the scheme on their large engines. But I see by your pages that the B. & O., also the Great Northern, are having large new engines for both freight and passenger service equipped with them.

Unity Station, Pa.

READER.

## Improper Repairs to Brake Valve.

Editor:

Sometime ago on a switch engine the engineer was unable to release the brakes with the engineer's brake valve, and after bleeding the brakes off he discovered that they could not be applied with the brake valve. After taking the brake valve apart



LAURENCEKIRK STATION ON THE CALEDONIAN RAILWAY, WHERE ANGUS SINCLAIR BEGAN WORK AS A TELEGRAPH OPERATOR.

protect or save many has been considered noble and heroic by the best minds of all ages past and will be so considered by the best minds in ages to come.

WM. WESTERFIELD.

Charleston, Mo.

## Position of Headlights.

Editor:

I would like to learn from those who have tried using headlights placed on the middle of the front end or on door of smoke box, what can be said in favor of the plan, also what objections they may find to it, and what kind of fasten-

there was found to be two upper body gaskets between the cap and the body which raised the cap too high from the body. The valve, however, worked all right until the stem washer had worn down too thin and this combination allowed the key to come out of the slot in the rotary, leaving the latter in application position. Any further movement of the handle did not affect the rotary valve.

From this it can be seen that great care should be given the repair of the brake valve, such as facing the rotary valve seat off too great an amount, or the placing of two upper body gaskets between the

cap and the body, either of which will have a tendency to separate the key from the rotary. Should a failure caused by this kind of work occur on an engine hauling a fast train, the consequences could be disastrous to both life and property, and no doubt they would be.

East Buffalo, N. Y. OLIVER SOLOMON.

**Boiler Check Arrangement.**

Editor:

A recent report of an engine failure and serious delay of an important train on one of the principal trunk lines, caused by an injector check being stuck

as to the advantages of this arrangement. For the benefit of those not familiar with the arrangement I will give the record of one of the engines I have so equipped. This engine was turned out of the shop June 14, 1906, and to date only one of the checks has ever given any trouble, and that was caused by a small piece of coal lodging on the seat of the check. In this case the engineer closed the valve at the boiler, opened the check and removed the piece of coal, taking in all about five minutes. The engines from the American Locomotive Company were

builders is that orders are executed with much more promptitude than is the case with either British or German locomotives. The Sampo Railway Company uses only American locomotives, but orders wheels and axles from Germany.

New York.

TRAVELER.

**Handy Shop Devices.**

Editor:

Sketch No. 1 represents a jack cart which is very convenient, being simple in construction, light as the service for which it is used will permit and the cost of construction is very small. You will note how low it sets on the floor, thus doing away with the necessity of two men handling a jack of any size; it also permits running the jack right up to the spot where it is to be set. The material necessary to make this cart consists of a few pieces of gas pipe, boiler iron, two small wheels and material enough for a small axle.

Sketch No. 2 shows a handy arrangement for use in packing piston rods. A piece of pipe having a clamp on it, which slides on the rod, fastened to a lever having a fork on it to fit over the gland. After the rod packing has been

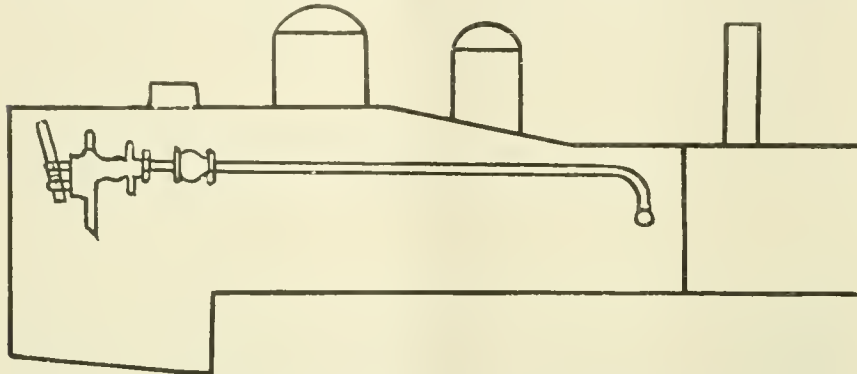

BOILER CHECK ARRANGEMENT.

up, brought to my mind a plan suggested in these columns some time ago, whereby the engineer could remedy such a defect and prevent an occurrence of this kind. Since taking charge of the equipment of this company, the Minneapolis & Rainy River Railway, I have followed the suggestion of the writer of the above-mentioned article and am equipping all engines as they go through the shop for

received during June and July, 1906, and we have not had the least trouble with delays on account of boiler checks.

Referring to the sketch, the valve at the boiler is either the boiler check converted into an angle valve or a heavy angle fitting and globe valve. The branch pipe rises from this and assumes a gradual bend to a point 2 or 3 ins. lower than the injector, when it extends in a straight line to the injector.

A straight-way swinging check valve is placed immediately outside the cab. The gradual drop in the branch pipe toward the boiler carries all condensation back to the boiler and prevents all possibilities of the pipes freezing, which in this climate is a common occurrence.

W. J. SHREVE.

Deer River, Minn.

**Locomotives in Japan.**

Editor:

It is a noteworthy fact that the German-built locomotive is rapidly coming into favor in Japan. From reports just issued it appears that the imports of locomotives from Germany increased nearly six times as compared with the preceding year. The United States also has more than trebled its imports of engines to Japan, while Great Britain has fallen off to third place. The preference for German engines is to be accounted for on the score of cheapness, German prices being about 25 per cent under those quoted by British makers. The advantage gained by American locomotive



FIG. 1. JACK CART.

put in the vibrating cup the gland can be put in place against the pressure of the spring. The sliding clamp when tightened in place goes against the crosshead and, moving the lever, puts the gland home and the nuts can then be tightened up. The device can also be used as a crosshead mover.

JOHN F. LONG.

Frisco System, Beaumont, Kan.

**Workmen's Compensation Act.**

Editor:

Railway men in the United States will be interested in the manner in which British law provides for their confrères on this side of the pond, so that a few points about the new act may be given. As the act covers every kind of workman and workwoman, with a few trifling exceptions, and, as it left the House of Commons, even domestic servants were included. It may be premised that the act makes insurance compulsory so that no bankrupt employer can escape his responsibility. When a man begins to employ workmen he must insure against accident to them, and in the event of accident,

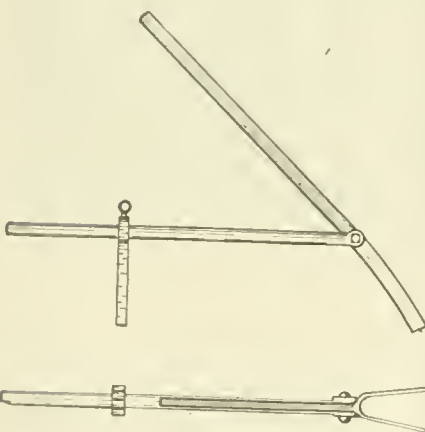

FIG. 2. CLAMP FOR PISTON ROD GLAND.

repairs with piping and mountings as shown on the inclosed sketch.

We recently received some engines from the American Locomotive Company, which I had equipped in the same manner, which I was told by the messenger that brought them that they caused no small amount of criticism among the enginemen along the route



having paid his premium, he is not unlikely to be an impartial witness in any claim upon the insuring company. In addition to every kind of accident resulting in injury to the person, such as a railway accident, entanglement in

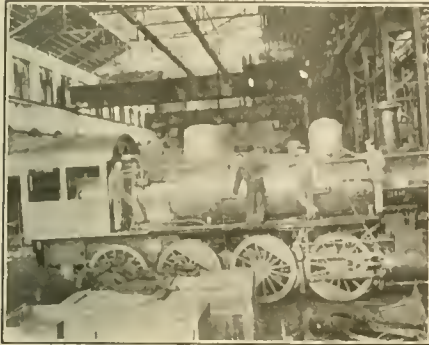

CHILIANS AT WORK AT BALDWINS.

machinery, while at work, falling from buildings and such like, there are a number of scheduled diseases resulting from certain forms of employment, and in the case of illness for more than two weeks or death from such combined employment and disease, compensation must be paid. For instance, hair-workers are subject to anthrax, which claims a good many victims annually, and there are a number of other forms of dangerous employment all specified in the schedule. Should death result from an accident or from one of the scheduled diseases, those dependent on the workman are entitled to a sum equal to his earnings during the three years immediately preceding, if he has been so long with the employer, or to £150 (\$750) whichever is the greater. Should the earnings be the greater the amount is limited to £300. Provision is made for the cases of men who may not have been three years in the employment of the firms with whom they worked when their accidents occurred, by multiplying the average weekly earnings while with their last employers by 156, and in the case of disablement either total or partial, the compensation is limited to half the average of the workman's weekly earnings, with the proviso that it must not exceed £1 (\$5) per week. There are a number of other provisions for exceptional circumstances, such as the case of a workman under twenty-one years of age, or one who returns to his employment partially incapacitated, or who is at the time of such return under twenty-one years of age, but whose earning power would probably have increased had no accident happened, and so on. The provisions of the act have been very carefully and thoroughly threshed out.

Glasgow.

A. F. SINCLAIR.

Suspicion is the substitute of the slothful for vigilance.

### Young Chilians at Baldwin's.

Editor:

Enclosed you will find some photographs of the Argentine Republic Engines. These engines were constructed by the Baldwin Locomotive Works for the "Gran Oeste Argentino" Railroad. In these engines as well as others the Chilean young men were very interested in the construction, as you can see by the pictures; these young men worked in overalls, showing how they get a knowledge of the work. I am sending these pictures only with the idea that they will be of interest to you or for publication if you desire it.

OTTO A. SCHMIDT.

### Taking the Air.

If you are curious to know the derivation of the word pneumatic, the dictionary will tell you that it comes from the Greek pneuma, air or wind, and this is further derived from peno, to blow. The termination, tic or ic, means pertaining to. Pneumatic, by derivation,



EXAMINING THE VALVE GEAR.

means pertaining to air. Greek for air, as it were. There is another and perhaps more rough and ready, though less accurate way of finding the meaning of the word, and that is by going into a certain boiler shop, as Ignoramus did once upon a time, and tackling the rather positive foreman on the subject.

Ignoramus happened along on the day when all the flange fires were lazily smouldering and smoking instead of glowing and spitting and roaring, at the half-flanged plates lying in them, and Ignoramus said blithely to the foreman, "What's the matter, now?" Mr. Positive gave him, as Squeevers used to say, one of those "oh-you-poor-ignorant-cuss" looks and replied, "Don't you see I haven't any air on the fires?" Then Ignoramus rushed in where angels feared to tread and left them all far behind; he said, "Yes, but I hear the caulking hammers going full blast, so you must have air." Mr. P. again looked at him in the same old way, only more so, and replied, slowly and solemnly and finally, as if to close up the matter for ever: "I'll have you understand

that there are two kinds of air in my shop—there is fan air and pneumatic air, and they are both different, and one can be off and the other on at the same time, or they can be both on together or both off together, and you don't have to worry about any of the several kinds of air we have round here. If you go outside and stand in the sun you'll get another kind." "Oh, thank you," said Ignoramus meekly, "I prefer to stay right here and obtain the calorific pneumonia direct from you."

### One Thousand Dollars Each.

Not long ago Mark Twain made a speech at a dinner of the New York Press Club. He said he had been a simple speller all his life. When a publisher offered him five cents a word for an article, do you think he would write the word policeman where "cop" would do? By no means; and again, he said, he could not be induced to use the word valedictudinarian for five cents. He wanted fifteen cents before he would let that word get into his articles.

Not long ago, at a meeting of a literary club in the Quaker City called the Franklin Inn, says the *Philadelphia Bulletin*, a young poet, licking his lips, said that Conan Doyle was paid \$1 a word.

"That is nothing," said a railway advertising man. "I know of a case where a man was paid \$1,000 a word. Our line used to have at its grade crossings a very long and complicated sign that began: 'Beware of the engines and cars,' and then this sign went on with a lot of injunctions and warnings that would have taken five minutes to read. In a number of accident cases the complainants for damages declared that our long signs were not clear warnings. Therefore the line decided at last to get a new grade crossing sign, and Judge Paxon was engaged to write one. The sign that Judge

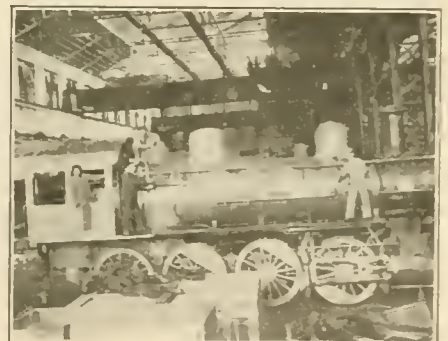

WORKING ON THE INJECTORS.

Paxon wrote cost \$1,000 a word, but it was a classic. It remains a classic. It is as well known among us as 'Father, I cannot tell a lie,' or 'England expects every man to do his duty.' The sign that cost \$1,000 a word, or \$6,000 in all, was the famous 'Railroad Crossing—Stop, Look and Listen.'

### Railroading as a Business.

"Transportation or the conveyance of persons or things from one place to another is probably one of the most ancient of occupations." These words occur in an article on the "Evolution of the Book of Rules," written by Mr. W. G. Besler, general manager of the Central Railroad of New Jersey, and

large bridge on the same division was then rebuilt upon a really conservative appropriation. However, the resident engineer contrived to save enough on this job to fix the little culvert and one or two other places. The following year, when the aforesaid culvert did not appear as needing repairs, the general office immediately inquired about

and mechanical departments. The mechanical department of an average American railroad directs 30 per cent of the total expenditures. Despite this, 'engines are butchered on the road and cobbled in the shop,' to quote Mr. Harrington Emerson. For American railroads to follow the lead of their commercial patrons and realize the possibilities of this department, its administrators must utilize the same essential principles as the conduct of an equally vast commercial proposition demands. Briefly, the application of simple business methods will put many a man upon the top of his job where previously he was merely 'It' in a system without adequate direction. A powerful initiative is inseparable from business ability. To conduct a railroad requires the same business attributes, from the stockholders' president to the gang boss, and no less, than to keep afloat a colossal industry on its by-products. The forceful men who have mastered these attributes find remunerative positions on every hand, ready to step into. The great railroad man of tomorrow will be he who operates most economically, just as yesterday it was the traffic man who secured the most business, and to-day is the financial man who consolidates and juggles values. This signifies the ultimate ascendancy of the mechanical department, just as the tradesman has supplanted the feudal baron, and is in turn being superseded by the scientific methods of the engineer."



PUTTING A LOT OF ENGLISH LANDSCAPE BEHIND THE REAR COACH.

were quoted by Mr. Paul R. Brooks in opening his paper on railroading from a business point of view, before the New York Railroad Club.

First, he said, directness is the staff of business. This means that concentrated responsibility must carry with it concentrated authority. A man must have the power to remedy existing defects if he is to produce results. A supervisor is asked for his estimate of new rails required. He says 800 tons. The division engineer takes off 400 so he will not have too much. The chief engineer takes off 50 per cent from that and the general manager looks at the 200 tons and says that nearly equals nothing at all, and so the supervisor gets none. Now either he is competent to run his department or he is not.

Expert special knowledge is often mistaken for executive ability. This throws the real load, the work of thinking on his superior. Officials in general are burdened with a largely senseless diversity of minor subjects under advisement. Net results are the only justification for any expenditure. Every listener, Mr. Brooks said, could quote from his own experience several improvements which were undeniable but which were lost in the volume of signatures required for their authorization.

"A small culvert appeared for three consecutive years in the list as being in need of repairs, and was as repeatedly crossed out at headquarters. A

the good shape of the culvert, in the absence of any authority to mend it. For some time afterward considerable correspondence was headed, 'Please say why.'"

A mechanical department man leaving railroad employ and entering a factory finds that the boundry line of net economy cannot be baggy except at the direct sacrifice of net profit. His new employers demand designs having lowest shop cost. They reject arrangements which would have been satisfactory on the road. Railroads should regard themselves as having a real profit and loss account.

In a fluctuating force poor men come and good men go. A small number of men kept continuously at work under a definite appropriation which takes all of the long summer days to get equipment in shape for the winter, will show a better annual balance sheet. The reason expenses go up when receipts go up is that they were previously forced down when receipts fell off. No business house expects to show a profit every day. Some run eleven months to pay expenses and the holiday trade creates the credit balance. Cutting pay rolls after a poor month's business, as railroads often do, is costly retrenchment.

In concluding, Mr. Brooks took a glance at conditions and practices abroad; he said:

"European railway practice recognizes the true importance of the operating

### Scientific Invention Practically Applied.

Probably one of the most interesting inventions, and one which is used in a great variety of ways, is the Bunsen burner. It was invented by R. W. Bunsen, professor of chemistry at Breslau, and later at Heidelberg, in Germany. The Bunsen burner is essentially one in which the pipe of a gas jet is surrounded by a sleeve, open at the bottom and extending above the orifice of the jet. As gas flows through the jet it draws air in at the lower end of the sleeve, and as it passes through the larger tube it becomes thoroughly mixed with air, and burns with a non-luminous but intensely hot flame.

One of the very interesting uses to which the Bunsen burner is put is its application to the Pintsch system of railway car lighting. The gas is supplied to the lamps by the regular pipe line extending along the outside of the roof of the cars and the supply to each lamp is delivered or cut off by a stop cock in each arm. The gas passes through each arm to which the lamps are suspended until it reaches the last fitting, which is practically a Bunsen burner. The gas issues through an extremely fine hole, mixing itself with air and the gas and air are

blown out in a downward direction. Before the mantle, which forms the prominent feature of this light, is applied, the gas appears almost to drip out of the jet as a gentle flame pointed like a crayon which burns blue at the rim and is light green lower down, but is intensely hot.

When this flame is enclosed in one of the specially prepared mantles made by the Safety Car Heating and Lighting Company of New York, it brings the mantle up to a white heat. One of these mantles, not much bigger than a walnut, hangs from each burner, something like a piece of fine meshed filtering cloth. Into this little bag or bulb or whatever you like to call the mantle, the downwardly flowing Bunsen burner flame falls and causes it to become incandescent and so produces a clear white light of great brilliance.

The mantle and globe are all one for practical purposes, and in case a mantle becomes defective, the globe can be unscrewed, carrying the mantle with it, and a new globe and mantle put in place without even the necessity of turning out the gas, and the whole thing can be done as easily as one would take out and replace an electric light bulb in a house or office fixture.

DOWNWARD  
DRIVEN  
BUNSEN  
FLAME.

In speaking of the hospital car on the Erie Railroad last month we referred to the lighting as being done with acetylene gas. As a matter of fact the car is equipped with the Pintsch light, the ward where the patients' cots are is lighted by four 4-flame lamps, and on account of the brilliance of the mantle lamps such as we have here referred to, the operating room is supplied with two 4-flame mantle mantle lamps, and there a few ordinary Pintsch bracket lamps in other parts of the car.

Speaking generally, a Pintsch mantle lamp about equals two sixteen-candle power electric bulbs, and the consumption of gas as quoted by the makers is something less than one cubic foot per mantle-lamp per hour. The mantles are protected by the globes when being handled and when in use, and they are said to last with fair usage about three months. The company has issued a very handsome and interesting catalogue dealing with incandescent mantle lamps for Pintsch gas, and they will be happy to send a copy to anyone interested enough to apply for one direct to them at their New York office.

### Railroad Equipment in the U. S.

The Interstate Commerce Commission gives the following facts and figures: On June 30, 1905, there were in the service of the railroads 48,357 locomotives, the increase being 1,614. These locomotives, excepting 947, were classified as: Passenger, 11,618; freight, 27,869, and switching, 7,923.

The total number of cars of all classes was 1,842,871, or 44,310 more than for the year 1904. This rolling stock was thus assigned: Passenger service, 40,713 cars; freight service, 1,731,409 cars, and company's service, 70,749 cars. These figures do not include cars owned by private commercial firms or corporations.

The average number of locomotives per 1,000 miles of line was 223, and the average number of cars per 1,000 miles of line was 8,494. The number of passenger-miles per passenger locomotive was 2,048,558, showing an increase of 100,174 miles, as compared with the previous year. The number of ton-miles per freight locomotive was 6,690,700, showing an increase of 233,854 miles.

The number of locomotives and cars in the service of the railways aggregated 1,891,228, of which 1,641,395 were fitted with train brakes, or an increase for the year of 86,623, and 1,871,590 were fitted with automatic couplers, or an increase of 48,560. Nearly all the locomotives and cars in the passenger service had train

The statistical report contains a number of interesting summaries, showing the general type and tractive power of locomotives and the capacity of freight cars by classes.

### Locomotive Water Tube Boiler.

The ordinary fire tube locomotive boiler performs as well as ordinary stationary boilers and has no more weak points, yet many engineers think that a water tube boiler would be better and inventors have done their best to design a water tube boiler that would satisfactorily endure the rough treatment that a locomotive boiler necessarily receives. When coal as fuel began to be used in American locomotives about 1850, several forms of water tube boilers were introduced, but they soon dropped out of use under Nature's law known as the survival of the fittest, which in this case was the common fire tube arrangement.

Repeated attempts have been made since that time to introduce water tube boilers on locomotives and considerable money has been wasted on experiments with such boilers, and others are still going on. We notice that a locomotive shown at the Milan Exposition was fitted up with a water tube boiler and great claims were made for its efficiency as a generator of steam.

With the contracted space available a



THE FLYER DOING UP FATHER TIME.

brakes, and all but 82 locomotives in the same service were fitted with automatic couplers. Only 1.63 per cent of cars in the passenger service were without automatic couplers. Substantially all the freight locomotives had train brakes and automatic couplers. Of 1,731,409 cars in the freight service on June 30, 1905, the number fitted with train brakes was 1,515,354 and with automatic couplers 1,715,854.

locomotive is very inconvenient for the application of water tube boilers. The only real advantage a water tube boiler has over one of the fire tube type is that there is less danger of an explosion. Those pushing such boilers, however, always pretend that they use less fuel in producing a given volume of steam.

It's no use looking like a lemon when you talk of loving your neighbor.

### Cycloid Curves.

We have several times had occasion to speak of a family of curves called the conic sections or "conics." These curves are derived, as their name implies, by the cutting of a cone by a plane placed at different angles to the axis of the cone. These curves are the circle, ellipse, parabola, and the hyperbola. The parabola is the one used in making a headlight reflector. There is another set of curves which are in a sense connected with an engine, called the cycloid curves. This word comes from the Greek, kuklos, a circle.

Among this family of cycloids there is the principal one, which is traced out when a circle is rolled along a straight line. You would get this curve if you had a pencil fastened to the extreme edge of the tire of a driving wheel and made it draw a line on a whitewashed wall beside the track. Such a curve would be the common cycloid. The line looks like a series of flat arches,

and where the pencil is down at the rail level there is a sharp point, some like the point of the old-fashioned spark deflector or cone that was used when diamond stacks were in vogue on locomotives, or the way the curved tracks on a Y come together.

lution of the driving wheel would be a shortened or curtate cycloid and it would have loops or nodes where the pencil came down near to and below the rail. If the pencil was put anywhere inside the driving tire, say on the centre of the crank pin, it would trace out a longer and flatter curve called for that reason a prolate cycloid, and the lowest point reached by the pencil would not make a sharp point or a loop but would form a sort of indentation like that made by a ball laid on a cushion.

Some of the properties of the common cycloid are curious. If you had a wash basin made in the form of an inverted cycloid and were to hold a marble at the upper edge, and also hold another about half way down or even less if you like, and let go of both together, each would reach the stopper of the waste pipe at the bottom of the basin at exactly the same instant, though the first had traveled a much

greater distance than the second. Now to compare the cycloid with other kinds of curves, let us suppose that you had a toboggan slide made in the form of an inverted cycloid, and also some more slides made in any other form of curve you know of, the party on the cycloid slide would get down first every time, if all started from the same height at the same time. The cycloid is the curve of quickest descent between any two points. It is used in making the outline for the teeth of gear wheels.

Each tunnel will have a single track; the north tube carrying the west bound traffic and the south tube carrying the east bound or New York traffic. The cars will be operated in trains by the Sprague-General Electric system of multiple unit control in a manner similar to that employed on the New York subway trains. Each car will be equipped with two 160 h. p. railway motors. Power for this new project will be supplied from a large station on the New Jersey side, located between Jersey City and Newark. Curtis steam turbines will be employed; initial equipments, including two 3,000 kw. 11,000 volt machines and two 6,000 kw. 11,000 volt machines. The total power so generated will be distributed at high voltage to three sub-stations where the alternating current will be stepped down to 650 volts direct current through transformers and rotary converters. There will be two sub-stations in New York, containing, respectively, five 1,500 kw. rotary converters and 15 step-down transformers, and two 1,500 kw. rotary converters and 6 step-down transformers. The Jersey City sub-station will have four 1,500 kw. rotary converters and 12 step-down transformers. Each sub-station will in addition contain one spare 1,500 kw. transformer. It is expected that when the new line is in operation, the running time between the various suburban cities of New Jersey and New York City will be reduced one-half. The General Electric Company will furnish the complete electrical equipment.

### Worked Beautifully.

"A book agent," says Harper's Weekly, "recently obtained admission to the office of Mr. Thomas Edison and assailed him with such an aggregation of arguments in favor of the publication which she represented that the famous inventor hurriedly subscribed. After a gradual restoration of his energies, Mr. Edison asked: 'How did you ever succeed in mastering such a long and convincing speech as that?'"

"'Oh, our speeches are taught us at the office,' responded the lady, sweetly, 'by means of the Edison phonograph.'"

### Restricted.

An Irishman was recently travelling in an English railway train accompanied by a minister, when two very stout ladies entered the compartment. They placed themselves one on each side of Pat, who was, of course, much crushed.

The minister, on seeing him so placed, said: "Are you sure you are comfortable, Pat?" To this question Pat quickly replied: "Sure, your reverence, I haven't much room to kick."



CULM BURNER, WHERE FIREMAN AND ENGINEER ARE TOGETHER IN ONE CAB. CANADIAN PACIFIC RAILWAY.

### Hudson Company's Tunnels.

The twin tunnels of the Hudson Company, connecting Jersey City with New York under the North River, represent the most recent development in electrical projects centering about Manhattan Island. Construction work on these tunnels was finished about a year ago and work of electrification has been go-

Patent Office Department.

BRAKE SHOE.

An improved brake shoe has been patented by Mr. A. G. Olberding, Cincinnati, Ohio. No. 835,463. The brake shoe has a steel back having a series of diagonal U-shaped straps struck down therefrom and a cast metal body joined to the back by the metal passing over and around the straps. The brake shoe is furnished with a hook at one end formed one end thereof, the lug being curved over by having an integral lug projecting from and crimped along its edges.

STEAM ENGINE.

Mr. C. L. Snyder, Versailles, Mo., has patented a steam engine. No. 837,429. The device includes a piston, a live steam chest and transverse valves therein at the ends of the steam chest, a cyl-

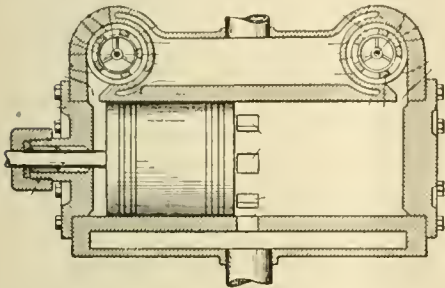

ROTARY VALVES AND CENTRAL EXHAUST.

inder communicating with the valve chambers and having in the centre of the cylinder a segmental series of exhaust ports. There is a segmental wall surrounding and spaced from the cylinder forming a steam chest opening into the exhaust ports and to the exhaust pipe.

SMOKE CONSUMER.

Mr. J. T. Wood, Vanwinkle, Miss., has patented a smoke consuming device consisting of a combination with the smokestack of a furnace of a foraminous resistance plate disposed in the smoke box and insulated therefrom and means for electrically heating the resistance plate. There is also means for imparting to the products of combustion a circuitous direction of travel toward the plate.

GREASE CUP.

Mr. Fred. Beebe, Ludington, Mich., has patented a grease cup. No. 839,539. The device embraces a combination with a cup of a rotatable plunger adjustably engaged therein and affording a closure for the cup, with a tubular shaft on the plunger and means on the outer end of said shaft acting when the plunger is rotated to open or close the passage in the shaft dependent on the direction of rotation. The cup is adapted for engagement on a journal bearing.

EXHAUST AND DRAFT REGULATOR.

Mr. T. B. Geisert, St. Paul, Minn., has patented an exhaust and draft regulating device. No. 837,462. It consists of a locomotive having in the smoke box a nozzle adapted to blow the exhaust steam into the regular smokestack, a secondary stack or pipe extend-

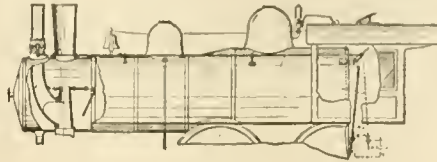

DRAFT REGULATING DEVICE.

ing from an opening in the side of the nozzle and up through the smoke box, a rod extending to the locomotive cab with a lever attached and means in the smoke box for opening and holding a valve in different positions regulating the amount of exhaust that passes through the smokestack or secondary pipe. The device is said to effect a saving in fuel.

SPIKE LOCK.

Mr. James Neil, New York, N. Y., has patented a spike lock that has already attracted wide attention. The

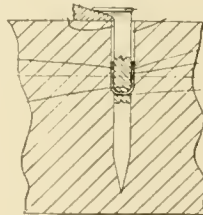

LOCKED SPIKE.

improvement on the ordinary spike consists of a transverse opening drilled through near the centre of the spike, into which a lock of flexible metal is inserted. In driving the spike into the sleeper the flexible metal lock bends and materially aids in maintaining the adhesive quality of the spike.

CYLINDER COCK.

A cylinder cock comprising in combination valves seating by gravity, a cylinder, a piston and a piston rod provided with cam surfaces and adapted to actuate the valves off and on their seats,

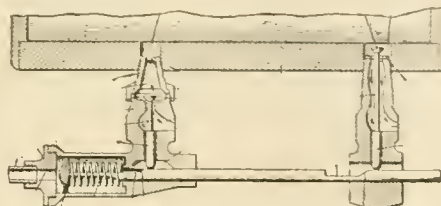

CYLINDER COCK RIGGING.

a spring actuating the rod in one direction, a pipe connection and a three-way cock controlling the supply of air or steam to the cylinder and discharge therefrom has been patented by Mr. E. H. Obertop, Chicago, Ill. No. 839,188.

LOCOMOTIVE ASH PAN.

An improved ash pan for locomotives has been patented by Mr. E. E. Nettleton, Quinter, Kan. No. 838,740. On the bottom of the ash pan there is a series of tilting doors with shafts carrying the doors at one edge and mounted to raise or lower the doors whereby the load of ashes is discharged. The edges of the doors extend downwardly and outwardly underneath the shaft of the door next preceding and designed to maintain the upper of the doors surface flush with each other.

BRAKE-SHOE.

Mr. W. D. Sargent, New York, N. Y., has patented a method of making brake-shoes whereby their durability is claimed to be much increased. The process consists in providing a back having attaching means thereon, placing the same in a mold in which the back forms one side, partially filling the space therein with fragments of metal and then pouring in molten metal to fill the interstices between the fragments. The alternate portions of malleable metal and cast metal are hardened in casting. Patent number, 839,038.

SPARK ARRESTER.

A patent has been secured by Mr. J. L. Pepper, Butler, Ind., for an improved spark arrester. No. 839,193. The contrivance is fixed in the forward exten-

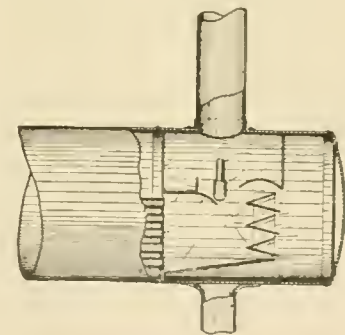

SPARK ARRESTER.

sion of a boiler shell and consists of a series of V-shaped baffle plates in vertical arrangement, having their apices rearwardly pointing and being separated by transverse openings. There is also a pair of deflector plates in cooperation with the upper baffle plate and with each other. The forward points of the baffle plates are separated to form transverse openings for the sparks. The combination forms means for directing the sparks to the baffle plates without interfering with the escape of the smoke and gases of combustion.

The Lehigh Valley Railroad have recently received from the Perth Amboy Dry Dock Co. 4 grain boats; the last one being No. 43.

# Railway and Locomotive Engineering

A Practical Journal of Railway Motive Power and Rolling Stock.

Published Monthly by

**ANGUS SINCLAIR CO.**

136 Liberty Street, New York.

Telephone, 984 Cortlandt.

Cable Address, "Loceng," N. Y.

Glasgow, "Locauto."

**Business Department:**

**ANGUS SINCLAIR, President,**  
**FRED M. NELLIS, Vice-President,**  
**JAMES R. PATERSON, Sec'y and Treas.**

**Editorial Department:**

**ANGUS SINCLAIR, Editor,**  
**GEO. S. HODGINS,**  
**JAMES KENNEDY,**  
**J. P. KELLY,** } Associate Editors.

**Advertising Department:**

Eastern Representative, **S. I. CARPENTER, 170**  
Summer St., Boston, Mass.

**British Representative:**

**THE LOCOMOTIVE PUBLISHING CO., Ltd.,**  
Amen Corner, Paternoster Row, London, E. C.

**Glasgow Representative:**

**A. F. SINCLAIR, 15 Manor Road, Ballahouston,**  
Glasgow.

**SUBSCRIPTION PRICE.**

\$2.00 per year, \$1.00 for six months, postage paid in the United States, Canada and Mexico. For other parts of the world, \$2.50, or ten shillings. Single copies, 20 cents. Remit by Express Money Order, Draft, Post Office Order or Registered Letter.

Mailing address can be changed as often as necessary—always give old and new address, and if you subscribe in a club, state who got it up. Please give prompt notice when your paper fails to reach you properly.

Entered at the Post Office, New York, as Second-class mail matter.

Copyright by Angus Sinclair Co., 1907.

For Sale by Newsdealers Everywhere.

## Clearinghouse Idea in Car Service.

There have been a number of reasons given for the annual recurrence of car shortage on railroads, and there have been various suggestions made, such as increasing the per diem charge and the introducing of reciprocal demurrage, etc. Although some of the suggestions, if carried into effect, would no doubt reduce the amount of the car shortage, it is hardly likely that they would do more. Not long ago a plan was proposed by a prominent railroad executive officer which practically amounts to a sort of community ownership of all the available railroad freight cars in the country. This was to be brought about by means of a central clearinghouse, effecting a car distribution among the railroads much the same as is now carried out between the several divisions of a single railway. The plan was outlined in three definite proposals which were addressed to the American Railway Association.

The clearinghouse idea was first worked out in the world of finance, and as applied to the banking system of any large city it briefly amounts to

this: Formerly each bank sent out a messenger with all the bills, checks, etc., payable at all the other banks of the city. The messenger delivered a batch of checks and made a settlement with one bank before proceeding to the next, and when business was heavy, considerable time was occupied in making the round. The clearinghouse system superseded individual collection and all checks received by all the banks are now sent to the clearinghouse each day, where they are sorted, added up, statements returned to each bank within an hour and balances settled later in the day.

Applying this idea to the problem of car distribution, the first proposition as already published reads, "Properly qualified railroads should be invited to sign an agreement to observe the rules of the proposed American railway clearinghouse for a definite period." This is intended to secure the fair trial of the clearinghouse plan of dealing with the question for a time long enough to ascertain if the principle be practicable and what modifications or improvements might be necessary to continue the whole as a workable scheme. This is the first effort to bring the clearinghouse idea, as applied to car distribution, down to definite terms, and the action of the committee on car efficiency who are considering the matter will be awaited with interest.

The next clause reads: "The directors of the clearinghouse should establish a standard for equipment. If any equipment be accepted which does not in value come up to the standard, the owner should deposit with the clearinghouse approved securities of sufficient value to make up the deficiency." Here the establishment of what may be called a standard car is proposed. Suppose, for example, that an average good wooden box car, such as is usually offered in interchange, be taken as the type and its value fixed, just as the M. C. B. rules now prescribe the values of cars and trucks when a settlement comes to be made after either have been destroyed. Having settled upon the arbitrary value of the style of equipment to be handled, any road offering to the pool a car having a less money value than the standard would be required to deposit approved securities so that the actual value of the car, plus the amount of the security deposited to make up the deficiency, will, when added together, compel each road to enter the pool with what amounts to the equivalent of a definite amount of money per car. In the event of any car being destroyed, the owners could then replace it by a new car or a substitute. Failing that, the action of the clearinghouse committee would be in order, and a car having the ar-

bitrarily fixed standard value would take the place of the one destroyed. The deposited securities would have the effect not only of making each road enter practically on the same money basis per car, but would give the clearinghouse committee something to draw upon, in case of necessity, in equitably maintaining the value of all equipment whether new, rebuilt, or newly entered.

The last clause reads, "The chairman of the clearinghouse should distribute equipment, so that each road shall have so far as possible at command a number of cars equivalent to those it has contributed. To effect this the chairman should have the power of penalizing railroads which delay or divert equipment." This clause refers to the actual work of car distribution, and under the pooling system each car, though bearing the name of the owning road, would be also marked so as to indicate that it had passed for the time being into the hands of the clearinghouse. With clearinghouse cars there would be no such thing as home routing. A car having made a trip from a point on one road to a point on another, as soon as empty, would be available for load in any direction and to any point. By this means the delay incident to waiting for a load in the home route direction would be avoided, and the light mileage of the car going either to the owning road or to some busy point where loads in the desired direction might be expected, would entirely disappear.

Suppose a road had placed 10,000 cars in the pool, this road would then have made practical demonstration of the fact that it was willing to interchange that number of cars, or that that was its estimate of the interchange business likely to fall upon it. This road would then have the right to demand from the clearinghouse the constant use of that number of cars on its own tracks for the purpose of interchange, its other non-pooled equipment being kept for local traffic as far as possible.

In the event of this road requiring, say 500 cars above its pooled equipment, the clearinghouse would endeavor to supply the cars, drawing upon the adjacent idle pooled equipment for the supply; these cars, if supplied, to be settled for by the using road at an amount which would be paid into the clearinghouse and credited to those roads which did not for the time require or happen to obtain their full quota. The amount paid by the using road and credited to those not fully supplied would be a fixed amount per car per day, and might, in times of car famine, be so increased as to represent not only a fair rental, but a certain proportion of the earning power of a car.

This higher figure would only be paid by the road in question for the cars over and above its pooled quota, and in the endeavor to keep this charge down as low as possible the road in question would endeavor to have every pooled car on its tracks unloaded at the earliest possible moment, so that it would not be compelled to ask for extra cars at the higher rental, or that having idle pooled equipment on its hands it might be able to deliver cars as directed by the clearinghouse to busier roads, and so be credited with the amount accruing from such delivery.

This is no doubt but an imperfect outline of the salient features of the scheme as it appears in its present form, and many details remain to be worked out before it could be adopted or become of practical utility. The plan, however, seeks to embody the principal of making each pooled car a sort of a circulating medium for the carriage of merchandise by which specific ownership and home routing for the time being disappears.

A press dispatch from Chicago of recent date indicates that this plan has found favor with some of the principal roads in the West. The dispatch states that "Among the railroads which have agreed to pool their freight cars are the Rock Island, 42,000 cars; Frisco system, 50,000; Chicago and Eastern Illinois, 20,000; Chicago and Alton, 11,000; St. Paul system, 46,500; Baltimore and Ohio, 40,000; Erie, 53,000; Harriman system, 70,000; Pennsylvania system, 120,000; Santa Fe, 40,000; Illinois Central system, 63,000. The railroads committed to the pooling plan own 542,500 freight cars out of a total of 1,800,000 in the country." So much for the agreement to try the plan; the next step is the working out of details and the formulation of rules.

The press dispatch referred to also mentions a meeting held not long ago of the presidents and leading traffic and operating officials of these lines, and of the formation of a committee to deal with the subject. The dispatch adds, "The following committee has been appointed to arrange details for a freight car clearinghouse: Arthur Hale, general superintendent of transportation of the Baltimore and Ohio Railroad; J. Kruttschnitt, director of maintenance and operation of the Harriman system; W. A. Gardner, vice-president, in charge of operation of the Northwestern system; H. I. Miller, president of the Chicago and Eastern Illinois, and Daniel Willard, vice-president, in charge of operation of the Burlington system." There is, therefore, every prospect that the scheme outlined above, or something like it, will be tried, and if successful other roads will no doubt enter the pool.

### Surprise Tests.

A recent press dispatch from the Windy City states that "The management of the Chicago and Northwestern Railway has just completed a remarkable demonstration. During 1906 the company made a series of 'surprise tests' numbering 1,625, and the record shows that there was not a single failure to obey the signals and to observe the rules governing block signalling. 'Surprise tests' are made without previous knowledge of the engine crews and consist of every conceivable question which may arise in connection with block signals." The dispatch should have said that every condition likely to arise on the road in connection with the signal system had been artificially reproduced.

There has been now and then a tendency in some quarters to regard surprise tests or surprise checking as it is often called, as an attempt to take an unfair advantage of the men, or at least as putting a needless tax on the vigilance of good men for the sake of possible delinquents. It speaks well for the good sense of railroad men of all ranks that such an opinion is confined to the very few.

Surprise checking is not necessarily a disguised effort to look for trouble, any more than an entrance examination is for a college course. Its object is to find out the actual state of affairs on the road, and the practice does not carry with it any imputation of untrustworthiness. It is as legitimate in railroad operation as that a man should weigh the sugar sent home by the grocer or that the cashier should count the money paid over the counter.

Surprise tests not only affect the men on the road but they react on those in authority as well. There have been railroad superintendents who were able to give a splendid lecture on duty and responsibility to a new man or to one just promoted and who seemed to think that having explained road rules very thoroughly they had done everything there was to do for all time, as far as the newcomer was concerned. The same superintendent would make a very poor army officer if he relied on a comprehensive exposition of the drill book to a company of recruits but failed to exercise them in the field. The whole tendency of military training today is to simulate as closely as may be, the conditions of actual warfare, and to value the behavior of troops according as they are able to march and camp out in all weathers and maneuver over all kinds of country. It is in fact the ability to meet actual conditions in the open rather than make a showy appearance on the parade ground, which counts for something in time of war.

There is an old legal maxim, generally couched in the Latin phrase "Caveat Emptor," let the purchaser beware; and in paying for the services of their employes the railroad is but doing a part of its duty to the public when it endeavors to secure the highest efficiency among its operating staff by the introduction of a fair, impartial and impersonal test of the fitness for the faithful discharge of responsible duties on the part of all those concerned. These tests are no more onerous than the examinations for promotion from one grade to another in railway service.

If the press dispatch quoted above is true the railroad mentioned is to be congratulated on the efficiency of the service and the men are to be congratulated on the record made by them, for it must be remembered that the behavior of each individual under various conditions contributed to the very satisfactory result. The figures given show that on the average more than four individual tests were made every day during the year and the men have responded in a straightforward, businesslike and creditable manner. Not only were the men vigilant, but the superintendents were in constant and close touch with the daily life of the road and when all work together with the word safety written large on individual performance the record makes very pleasant reading for the traveling public.

### Headman or Induna.

History repeats itself, and the careful observer of men and things may be able to trace a resemblance to a certain fundamental idea in the minds of men though its manifestation may be surrounded by widely different conditions and separated by many years.

In the older and ruder forms of civilization, when mankind dwelt together in tribes, a leader was a man naturally endowed for the place he achieved and held. Such a man was strong, active, skillful, alert and subtle of mind, a master of force, if not of suasion, the headman of the village, the Induna, as Kipling would call him, and his spear was longer and his thrust was heavier than that of those who called him chief. He was in modern phrase the master workman when war and hunting were the kindred and the only trades they knew.

In our own times, when men not yet old were boys, the machine shop had its boss, who, like the tribal headman, was held in high esteem according to his ability to justify his right to hold his place, not as director, but as the master workman. To be, in fact, the Induna of the shop. If one of his men fell ill, he would at a pinch do the work of the absentee in quicker or in better style. If a man was ignorant or stubborn the fore-

man showed the workman how, or did the job in spite of all opposition.

This was a stage in the evolution of the foreman from the lower grade of boss, but it suited those days and the small shop. Many a time the master workman in authority demonstrated his inability to govern and direct, but as time went on he developed the qualities which go to make what we call natural leadership, just as oftentimes the tribal headman showed himself to be the revered adviser at the council fire.

Nowadays the successful foreman is more than the simple master workman in authority. This age of specialization demands that he shall be capable of general shop direction, and not alone the fastest in the execution of a certain piece of work. He must fill a wider angle than did his predecessor of years ago.

It would not be considered right for a colonel of artillery to devote himself to the laying of one gun in his battery, because a bombardier had failed at first to find the range. The colonel's duty on the field is to see that all the guns are in position, that all are properly served and that the fire is skillfully directed, or if one may so say, the officer should see that the output of the battery shall be of the greatest value to the army as a whole.

We are beginning to use words as railroad titles which have in them a wider significance than that of simple excellence in the use of tools. Supervisor in the maintenance of way and signal departments, and shop superintendent and works manager in the motive power department may be straws upon the surface, but they show how the current flows.

#### Duty of a Doctor.

A singular case of professional ethics was discussed lately in the British Medical Journal.

"Whole-time medical officer of health" writes: "A medical practitioner has consulted me under the following circumstances. He is attending a railway signalman for asthma. The attacks come on suddenly and are so severe that the patient falls on the floor struggling for breath and is totally incapacitated for an hour or longer. He has not yet had an attack in his signal-box, where he is on duty alone, sometimes for many hours at a time.

"The man declines to inform the railway company of his illness, thinking it would result in his discharge or, at least, reduction of wages. The doctor is afraid that if he reports the case to the railway company, who are not his employers and are, therefore, not entitled to a report from him, he will have to stand an action for damages brought against him by the patient.

"On the other hand, he fears that unless he breaks the seal of professional secrecy there will probably be a railway

accident, possibly on a large scale, as many London and other expresses traverse the line.

"I have advised him to make, in the public interest, a confidential report without delay to the general manager of the company, but as the doctor is reluctant to do this I hope you will also give your advice as speedily as possible."

The British Medical Journal adds an equally remarkable comment as follows: "In our opinion the circumstances, extreme though they be, cannot be held to justify a breach of the law of professional secrecy.

"While the medical man should represent the criminal neglect of the patient if he does not explain his position to his employers, the former ought not to write direct to the railway company without the patient's consent, he fully understanding the nature of the communication to be made."

[We should like to have the views of our readers on a case like this, supposing that the sick man was a locomotive engineer.—E.D.]

#### Matterhorn Railway.

The Matterhorn is perhaps the most famous of the mountains in Switzerland. It has been simply described a "cruel peak," as it stands straight up in its solitary grandeur. The ascent of the Matterhorn is considered to be a bold feat even among experienced and hardened mountain climbers. A project is now on foot to build a railway to the summit of this mountain.

The first section of the road, that from the village of Zermatt to the Alpine Club's house, will be the ordinary rack railway generally used in such cases. The ascent on this portion of the line will be 10,000 feet. The second part of the road will consist of an almost perpendicular tunnel driven upward with an 85 per cent grade, through solid rock, to a point within 60 feet of the actual summit. This point is 14,780 feet above sea level, or nearly three miles high. The very steep portion will probably be worked as an inclined elevator.

The summit station will be of large size, hewn out of the rock, and there will be several galleries, also cut out of the rock, which will afford the visitor a chance to enjoy the magnificent panorama of the Italian and Swiss Alps. Nor will this eagle's eerie be without the comforts which modern travelers expect. An apartment is to be provided in which compressed air and oxygen can be used for the purpose of relieving sufferers from mountain sickness, caused by the rarity of the atmosphere at that dizzy height.

The trip to the summit now takes about twenty-four hours and is extremely dangerous in any case and almost impossible in bad weather. With guides it costs about \$40. When this railway is built the

trip will be made in less than three hours and the railway fare for the round trip will be \$10, rather expensive for a three-mile journey, but these are almost three plumb miles, it must be remembered, and the view at the top is certainly one of the grandest on earth. It is expected that it will take four years to build the road and it will probably cost \$2,000,000.

#### Easily Made Repairs.

A thoughtful superintendent of motive power of a large railway visited our office a few days ago and the conversation drifted to the subject of easily made repairs and the importance of designing locomotive parts so as to preclude the possibility of failure or at least to bring failures down to what diplomats would call the irreducible minimum. Many engines are designed so that, although they may work well enough, yet are so difficult to repair as to make them exceedingly troublesome and very expensive to the small shop, and the railway owning them has to put up with the trouble and pay the bill, whatever it may be. Our friend dwelt upon his own experience in the matter of the badly counterbalanced engines, and was of the opinion that this defect was responsible for many failures which were otherwise unaccountable or usually ascribed to other causes. Time and money expended in properly counterbalancing engines would bear fruit not merely in the comfort of the crew, but in the absence of annoying failures and consequent interruptions of traffic.

In the matter of design he instanced his policy of not case hardening motion pins, but having them work in hard bronze bushings. This had the effect of reducing the rapidity of wear, and in the event of failure, or after legitimate wear had taken place, they were capable of easy and quick repair at any shop on the road. For example, spring rigging where a U-shaped hanger was united to a knuckle by means of a pin. These, he said, can be so made that a feather key in the hanger ends will prevent rotation of the pin and so eliminate wear from the holes in the hanger, and if the knuckle be bushed with hard bronze, the slight turning motion will produce but an insignificant amount of wear on pin and knuckle.

The idea of easy repairs is capable of almost indefinite extension, and it produces a unity of practice, and is responsible for the reduction of much extra work, and when such work has to be done, it enables it to be quickly and cheaply accomplished. One of the most important qualifications of a mechanical engineer on a railway to-day is to keep his eye on mechanical details, not only for the purpose of simply standardizing equipment, but of putting repair work easily within the ability of the small shop to handle with dispatch. It is not much of a job



if you have a good one beside you, and can reach the defective one, but it may be a very troublesome undertaking for a man with poor appliances when the light that failed happens to be in the dome of a lofty building, and under the circumstances it is an advantage to have a lamp designed and made so as to give maximum service.

#### Soft Hammers.

Soft hammers are soft now only in name. Thirty or forty years ago there were hammers made of babbitt, that were really soft and left no mark on a rod strap. Now they are made of scrap copper or dross of bronze or other indescribable compounds. Knuckles and corrugations gather on their wrinkled faces and their impressions can be seen and felt all around the twentieth century locomotives. The polished cross-heads are bruised and dented like the shield of Launcelot by the blows of circumstance. Valve rod bolts and keys are battered out of recognition. Even the piston glands bear sad traces of the unkindly thumps that they have received. The chief point of attack, however, is the rod straps. The distressful strokes from which they suffer begin before the engine has left the shop. In coupling up the rods there is necessarily more or less experimenting with liners to adjust the rod to the exact distance as well as to secure the correct adjustment of the bolt holes. The mechanic who has ever finished a strap knows that there is a silken softness about a finely finished strap or other highly polished, unhardened metal. He begins operations with a block of wood. The soft hammer breaks the wooden block into a thousand pieces and there is no time to keep up the supply of timber, so in the general hurry and confusion incident on getting the engine out the alleged soft hammer begins to get its work in.

In a few months the strap not only presents a very sorry appearance, but the mechanical effect of the blows has been such that the outer surface of the strap has become lengthened and the strap has closed up at the free ends, while the solid end has by repeated hammering become crystallized and is in a condition that is ready to go to pieces when the psychological moment arrives.

Hammers of lead or babbitt are comparatively harmless and easily made. Small bars of lead are very useful in adjusting the finer parts of a machine. The bar can be readily held on the strap, or key, or bolt head and a straight and effective blow can be struck by the ordinary hand hammer. In any event the copper hammer, so called, should be abolished or reformed altogether. The element of durability is its worst feature. It hardens as it

grows older. Its blows mar the finest features. Like the leprosy or the small-pox, its victims are known at a glance. Nothing on the modern locomotive seems free from the pernicious effects of the soft hammer from the brake hangers up to the boiler checks.

#### Pennsylvania Railroad Tubes.

The art of driving a railroad tunnel, working from both ends at the same time, has been brought to practical perfection, as was recently shown in the case of the Pennsylvania tubes under New York. When the headings met the lines given by the civil engineers were found to be only seven-thousandths of an inch out of grade and three-hundredths of an inch out of line. Such infinitesimal divergence can only be detected by mathematical instruments, and the larger error of the two is probably much smaller than the thickness of the paper upon which these words are printed.

The tunnel, when finished, will be 42 ft. wide and 21 ft. high, and a dividing wall will be built in each, so that under every street there will be practically two tunnels from Fifth avenue to the river. Between Fifth and Seventh avenues there will be one large tunnel with three tracks in it. The setting in of the concrete lining has been begun under Thirty-second street and the work is being vigorously carried on. The work of tunnelling beneath Thirty-third street began last March. The rock was found to be of good quality, and timbering was only occasionally necessary and progress was rapid. The meeting of the headings took place on January 4.

#### Book Notices.

*Locomotive Performance*, by Prof. W. F. M. Goss, M.S., D.E. Published by J. Wiley & Son, New York. Octavo, 439 pages, 229 figures, cloth, \$5.00.

Professor Goss has performed a notable work in collecting the data that has been accumulating in the Purdue University for a number of years in regard to the performance of locomotives. These valuable researches have appeared from time to time in the proceedings of the leading scientific and technical societies, and were to a great extent out of the reach of the general locomotive constructor. The collection and condensation of these researches into concrete form has been an important task and it is fortunate that the work has fallen into the hands of such an accomplished authority as the learned professor. The work may be said to embrace the labors of many skilled men. The trustees and president of Purdue University have supplied the means, the faculty have assisted in working out the problems, students have aided, and

skilled assistants have classified the data, and out of this valuable mass of material Professor Goss has produced a volume of absorbing interest that cannot fail to meet with a hearty welcome from all who are interested in locomotive construction and performance.

*Electric Wiring and Construction Tables*, by H. C. Hortsman and V. H. Tousley. Published by F. J. Drake & Co., Chicago. Bound in Morocco. Pocket size. Price, \$1.50.

This is a practical hand book, giving in a complete and concise manner the information which wireman, foreman, contractor, engineer or architect are in daily need of, and which without the aid of such a book requires tedious calculations. The work has the admirable quality of being free from unnecessary matter usually included in works of this class. The authors have conceived the happy idea of presenting what is really needed for practical men, and have displayed excellent judgment in preparing tables that show at a glance the currents required with any of the systems in actual use, of any voltage, efficiency or power factor, and by a very simple process, the proper wire for any loss. We commend this excellent book to all who are occupied in electric wiring construction. Every page is valuable. It has the element of simplicity, an uncommon feature in such books, and requires very little electric knowledge to understand every page of it. The typography and binding worthily sustain the publisher's high reputation.

*Boiler Waters, Scale, Corrosion, Foaming*, by W. W. Christie, M. E. Published by D. Van Nostrand Co., New York. Octavo, 320 pages, 77 illustrations, cloth, \$3.00.

It is fortunate that Mr. Christie, one of the leading mechanical engineers in New Jersey, has taken pains to produce a volume that will be especially welcomed by all who are interested regarding the troubles arising from the use of water in boilers and remedies that may be used or applied. The Railway Master Mechanics' Association has done much in the way of making progress in the softening of water for locomotives, and the same line of work has been supplemented by manufacturers and industrial corporations. Mr. Christie has taken full advantage of the reports of these bodies and conducted a series of important experiments extending over many years and presents the results in a consecutive and interesting manner. His style has the fine quality of directness. The illustrations are in the best form of the illustrator's art, and the work is altogether worthy of popular approval among all interested in the action of water in boilers.

### Javanese 4-4-0 Engine.

Our illustration shows a two-cylinder passenger compound locomotive with four axles, two of which are coupled. Several of these engines have been built by the Hannoverische Maschinenbau Actien-Gesellschaft for the Dutch State Railways in Java. These engines are fitted with Hardy's vacuum brake and Lindner's starting mechanism. This latter mechanism consists practically of a cross-cock, working automatically, which, when the valve motion opens to the fullest extent, as on starting, and allows live steam to enter the low pressure cylinder by means of auxiliary tubes. When the admission of steam to the cylinder is normal, the cross-cock closes the auxiliary piping, so that the locomotive is made to work in compound. The two front axles of the locomotive are placed in the bogie, and the other two are for the drivers. The

cial asbestos, one known as Amphibole. This word comes from the Greek, meaning doubtful, as originally it was not known how it was formed. This substance is comparatively little used, as the fibers are short and without much tensile strength and therefore are not suitable for the purposes of manufacture. It is used to some extent in cements, but even for this it is not particularly well suited.

The other form of asbestos is called Chrysotile. This has a strong silky fiber. It is a variety of serpentine. The fibers are longer than those of the other variety, and Chrysotile lends itself readily for the making of such materials as asbestos fabrics, household utensils, theater curtains, clothing for firemen, etc. Just here it may be remarked that asbestos is a fire resisting material of high quality, but in the solid

earth-flax and mountain-cork. It is the fabulous "unquenchable stone." This name is derived from the effects of water on quick lime, with which asbestos is often associated. The ancients, ignorant of the chemical combination which took place, wrongly ascribed the production of heat when water came in contact with lime to the presence of this unquenchable stone.

### Nails, Ancient and Modern.

The first nails were undoubtedly the sharp teeth of various animals; then, it is believed, pointed fragments of flint followed. The first manufactured metal nails were of bronze. The nail with which Jael killed Sisera was a wooden tent-pin, probably pointed with iron. Bronze nails have been found in the Swiss lake dwellings, in several places in France, and in the Valley of the Nile.

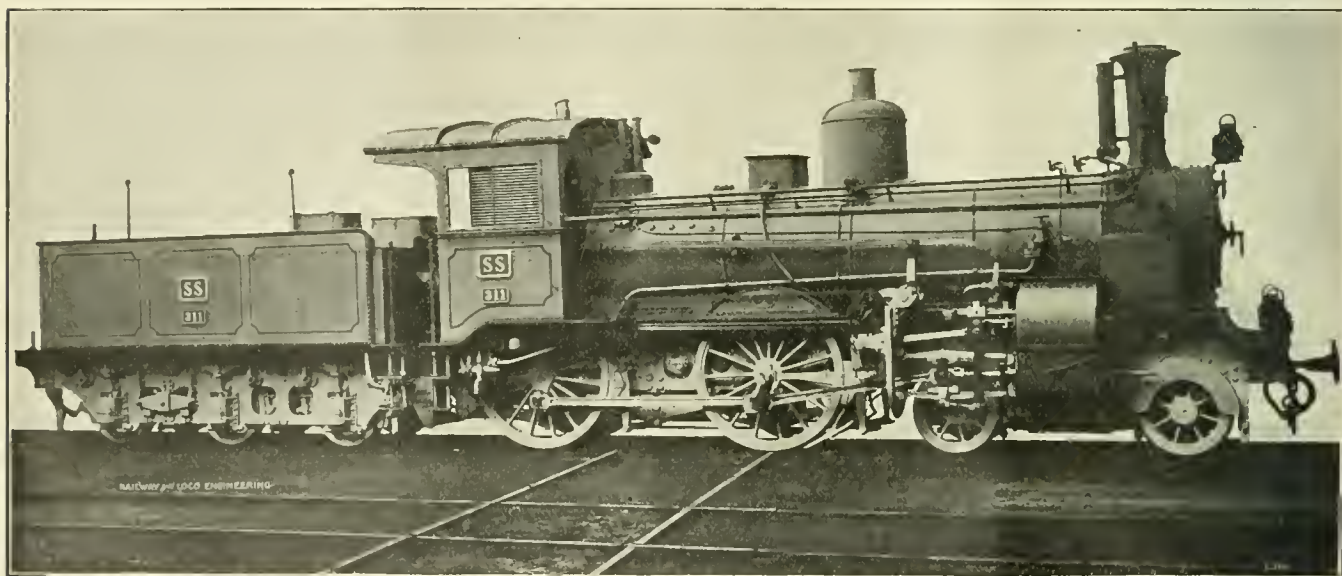

MODERN 4-4-0 FOR THE DUTCH STATE RAILWAYS OF JAVA.

walls of the water tank of the tender are galvanized to prevent rust.

Some of the dimensions of the engine are as follows: Gauge of track, 41.93 ins. Cylinders, 14.93 and 22.79 by 20.04 ins. Diameter of driving wheels, 58.95 ins. Diameter of engine truck wheels, 30.44 ins. Rigid wheel base, 7 ft. 10.3 ins. Total wheel base of engine, 20 ft. 2.8 ins. Steam pressure carried, about 175 lbs. Grate area, about 11.10 sq. ft. Total heating surface, about 1,011.8 sq. ft. Water capacity, about 2,378 U. S. gallons. Coal capacity, 6,600 lbs.

### Unquenchable Stone.

It is said that the Emperor Charlemagne had a table cloth made of asbestos, and that it was cleaned by being thrown on the fire and all the stains burned out. Prior to the year 1850 this substance was looked upon as a curiosity and was practically unknown in the arts.

There are two varieties of commer-

form can itself get very hot. When used as a non-conductor of heat it is generally in the porous form and the minute air cells which it then contains, as well as its own quality as a fire resistant, makes porous asbestos an exceedingly durable non-conductor of heat. In Germany, asbestos is called steinflachs (stone flax) and the miners of Quebec give it quite as expressive a name—*Pierre coton* (cotton stone).

Asbestos is mined in open pits, similar to stone quarries, and although it is found in all parts of the world, the mines in the Province of Quebec in Canada are the most famous, yielding about 85 per cent. of the world's supply of Chrysotile. Probably the largest of these mines is that owned by the H. W. Johns-Manville Co., of New York. In 1879 the output of the Quebec mines was 300 tons, which has steadily increased year by year to 50,000 tons in 1905. Asbestos is sometimes called

Until the last century iron nails were forged, a blacksmith being able to make only two or three dozen a day. The first cut nails were made by Jeremiah Wilkinson in Rhode Island in 1775. The first patented nail machine was by Perkins, 1795, and its product of 200,000 nails a day was considered so enormous that some persons deemed the result due to a supernatural agency. Many improvements in nail-making machines, greatly increasing the quantity and quality of their output, have been made in the present century.

The telephone, an invention for reproducing the human voice by the agency of electricity at long distances from the speaker, is due to the ingenuity of Elisha Gray, of Chicago; Prof. A. Graham Bell, of Washington; Prof. A. C. Dolbear, of Tufts College, Massachusetts, and Thomas A. Edison, of Menlo Park, N. J.—*Journal of Education*.

# Our Correspondence School

In this department we propose giving the information that will enable trainmen to pass the examination they are subjected to before being promoted. If any of our students fail to understand any part of the instructions, we will gladly try to make them plainer if they write to us. All letters intended for Our Correspondence School ought to be addressed to Department E.

## Third Series—Questions and Answers.

235.—Orders once in effect, continue so how long?

A.—Train orders once in effect continue so until fulfilled, superseded, or annulled. Any part of an order specifying a particular movement may be either superseded or annulled. Orders held by, or issued for any part of an order relating to a regular train become void when such train loses both right and schedule as prescribed by Rules 4 and 82, or is annulled.

236.—Suppose you should receive an order giving you rights against an opposing train, and before meeting that train and executing the order you should become over twelve hours late, what would you do?

A.—If a regular train received such orders and became over twelve hours late before fulfilling the order, the regular train would lose both right and schedule and the order would become void, and the train would thereafter have to proceed only as authorized by the dispatcher. If the train was an extra, the order would remain in force.

237.—What signals are provided at each train order office?

A.—Answer according to the practice on your own road as to the number of signals, but it is imperative that a fixed signal be used at each train order office. This signal shall indicate "stop" when there is an operator on duty, except when changed to "proceed" to allow a train to pass after getting train orders, or for which there are no orders.

238.—For what are they used?

A.—To insure the stopping of trains so that orders may be delivered or to authorize the passing of the station, by a train for which there are no orders.

239.—Are separate signals provided for the trains in each direction?

A.—Answer according to the special rule of the railroad company.

240.—When both signals are mounted on the same post, by which signals are trains governed?

A.—Where there are two train order signals at a station the movement of a train is governed by the train order signal which gives the indication for the particular direction in which that train is moving.

241.—When they are mounted on

separate posts, by which are trains governed?

A.—When train order signals are mounted on separate posts at a station, a train is governed by the train order signal which is generally placed in advance of the usual stopping place of the train which is moving in the direction governed by that signal.

242.—If red is displayed by the signal at a train order office, what must trains do?

247.—How are the positions indicated at night?

A.—They are indicated by colored lights. A red light indicates the horizontal or "stop" position of the semaphore arm, a white light is used on some roads, and a green light on others, for the inclined or "proceed" position of the arm.

248.—Do these signals in any way relieve trainmen from the duty of properly protecting their train?



ANOTHER VIEW OF LAWRENCEKIRK STATION ON THE CALEDONIAN RAILWAY. IT WAS THE SCOTTISH AND NORTH-EASTERN WHEN ANGUS SINCLAIR BEGAN RAILROAD WORK THERE.

A.—All trains must stop at that station, whether they hold orders or not.

243.—What will authorize a train thus stopped to pass the red signal?

A.—While "stop" is indicated, trains must not proceed without a clearance card.

244.—If white is displayed, what may trains do?

A.—They may proceed.

245.—When a semaphore is used, what position of the signal means red?

A.—The arm indicates "red" or "stop" when it is horizontal.

246.—What white?

A.—"White" or "proceed" is indicated when the arm is in the inclined position.

A.—No.

249.—When the train is stopped by the signal, what must the conductor and engine man immediately do?

A.—They must ascertain if there are orders at the station for them; even after receiving orders they must not proceed if the signal remains at "stop" unless in addition they have received a clearance card.

250.—How are the regular trains designated in orders?

A.—Regular trains are designated by their numbers as "No. 10," or as "2d No. 15" with engine numbers added if required by the practice of the railroad.

251.—How are extra trains designated in orders?

A.—Extra trains are designated by the word "Extra" and engine number and direction as "Extra, 422, North."

252.—How is time stated in orders?

A.—Time is stated on an order in figures.

253.—As conductor or engineman of No. 37 holding orders reading: "No. 37 and No. 42 will meet at Greenwood," what would you do?

A.—As conductor or engineer of No. 37, would proceed to Greenwood and wait there for No. 42.

254.—What would you do if on No. 42?

A.—As conductor or engineman of No. 42, supposing No. 42 was the inferior train by class or direction, assume right over No. 37 to Greenwood and proceed to Greenwood prepared to take the siding and wait there for No. 37.

255.—As conductor or engineman of No. 37, what would you do if No. 42 displayed classification signals?

A.—If No. 37 was the superior train by class or direction and No. 42 arrived with classification signals. No. 37 would wait until all sections of No. 42 had been met at Greenwood.

256.—As conductor or engineman of No. 42, what would you do if No. 37 displayed classification signals?

A.—No. 42 would wait until all sections of No. 37 had been met at Greenwood.

257.—Why in either case would you wait for all sections?

A.—Because as no particular section was specified in the order all sections are included and should have been given copies of the order.

258.—If the last section of the train arrives without markers, what would you do?

A.—Would wait at Greenwood, because a train must not be considered as having been met until its markers have arrived.

259.—As conductor or engineman of No. 42, holding orders reading: "No. 42 and Extra 569, South, will meet at Junction City," what would you do?

A.—Run to Junction City and wait there for Extra 569, South.

260.—What would you do if on Extra 569?

A.—Assume right over No. 42 to Junction City, and run to Junction City prepared to take the siding and wait there for No. 42.

The telegraph was invented by Samuel F. B. Morse, of Charlestown, Mass., in 1837, five years after he began experimenting. He obtained his first patent in 1840, and in 1843 Congress appropriated \$30,000 for its development.—Journal of Education.

Calculations for Railway Men.

BY FRED H. COLVIN.

Of course, most of the railway shop work that takes much calculating is repair work and it may happen that an engine comes in which has to have a bolt drilled out and a new one put in. If we drill on the exact center we can get the old bolt out and put in a new one of the same size in its place, but if we do not, we must drill it out larger and tap for a larger bolt or screw as the case may be. In either case, we want to know what size drill to use or, in other words, what the diameter of the bolt is under the thread. These are all worked out in tables, but tables are usually mislaid and we are apt to guess at the size, but the actual size can be readily figured out and it is a good thing to know how.

If it is a sharp "V" thread we can readily see how deep it is by making a

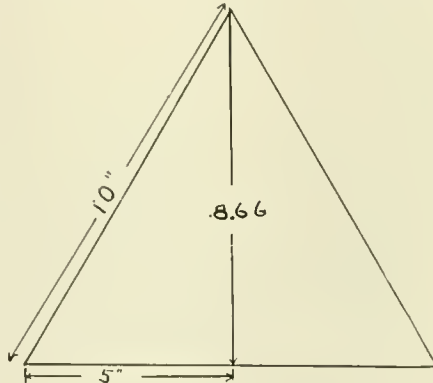

FIG. 2.

drawing of a one-inch pitch and measuring the depth in that way so that we will have a check on any figuring we may do. We find that the depth is .866 of an inch for a one-inch pitch and for a 10 pitch it would, of course, be just one-tenth of this, or .0866 of an inch. This is for one side and for both sides of the bolt it will be .1733 of an inch. We can prove this by figures and it will also give us a rule that will be handy in many places.

The vertical or perpendicular height of any triangle is always the square root of the difference of the squares of both sides. Sounds kind of tough doesn't it? But it isn't. Just multiply each side by itself, subtract one from the other and then take the square root of the difference.

Suppose we have a triangle 10 inches on each side instead of one inch as we took before. A vertical line divides the base into two equal parts or makes it 5 inches. Then we multiply 10 by 10 and get 100 and multiply 5 by 5 and get 25. Then we subtract them and get 75 as the difference. Now to

the square root and this is the hardest part of all unless we go into a long-winded explanation which, probably, is unnecessary, as most people know it. But for now it is much easier to refer

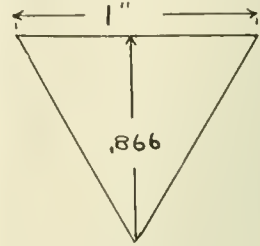
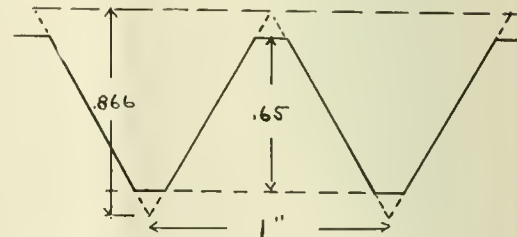

FIG. 1.

to a table of squares such as is found in Kent or any good engineers' pocket book and we find that the square root of 75 is 8.66. As the triangle is ten times the size of our one-inch triangle representing the thread, we divide this by ten and find the height to be .866 and that we were right before. It also shows how we can check up calculations or measurements by each other and that it is a good plan to know both ways.

Now supposing the bolt to be one inch in diameter and to have a 10 thread and we find the diameter under the thread by subtracting .1733 from 1 which leaves .8267 of an inch, or practically 53-64 of an inch. In drilling out an old bolt it might be safer to take a 13-16 drill, which would allow for a little running to one side, but for tapping a hole it might be better to use 27-32 to allow for the metal forcing up in tapping and then an absolutely sharp thread is not desirable except in special work.

In fact, we are coming to use the flat top and bottom thread a great deal now, commonly known as the United States Standard, or Franklin Institute or Sellers thread. This is the same as the "V" except that 1/8 of the depth is taken off top and bottom, leaving it



SECTION OF U. S. S. SCREW THREAD.

only 3/4 as deep or as high as the old "V" thread. This makes a better thread in almost every way and for this we have to drill out a larger hole. Three-quarters of .866 is .65 and multiplying this by two for both sides we have 1.3 as the depth instead of 1.73.

The hole for the one-inch bolt tap

then, with the standard thread, will be 1 minus .13 or .87 of an inch, which is practically  $\frac{7}{8}$  of an inch and this would be the drill to use.

Now let us make this into a little formula or rule by taking all the facts we have dug out and putting them in such shape that we can easily remember them. The size of the drill (or the diameter at the bottom of the thread) is the outside diameter of the bolt or tap, minus 1.73 divided by the number of threads per inch for a "V" thread and 1.3 for a standard thread.

Put in the shape of a formula we would say:

Let D = size of drill to be used.

Let T = outside diameter of tap.

Let N = number of threads per inch.

Let C = constant which is 1.73 for "V" threads and 1.3 for U. S. Standard thread.

Then  $D = T - (C \div N)$  so we simply fill in the right numbers in place of letters and we have the rule in the most compact shape possible.

What size drill should be used for a  $\frac{7}{8}$ -inch tap with 9 threads to the inch, which is standard, and U. S. S. thread?

Then  $D = \frac{7}{8}$  or .875 —  $(1.3 \div 9)$ . Before we can subtract we must simplify the fraction by dividing it and we get 1.3 divided by 9 equals .144. So we simply subtract .144 from .875 and get .731 as the right diameter. A table of decimals shows that to be nearest to 47-64, which is the drill to use.

The beauty of such a rule is that you can use it for any thread and for any diameter and it is useless to try and remember the right diameter for each case. Just remember the 1.3 for U. S. S. threads or the 1.73 for "V" threads, as the case may be. These are easy figures to remember and then you have the whole thing always with you without referring to any book or table.

While we are talking about triangles, and threads are all triangles except for the abbreviated tops and bottoms on the U. S. S. brand, it will be well to go a little further and understand some of the whys and wherefores.

The rule as given for finding the height of the triangle forming the thread applies in all cases if you read it right. Take the triangle shown in figure 3 and we have an apparent contradiction but when we extend the base of it by a dotted line till it is at right angles to the top, we can use it as before.

Measure the distances A B and A C, multiply each by itself and subtract the smaller from the larger. Find the square root of the difference and we have the vertical height B C.

Reversing the operation we can find the length of the slant side by multiplying each side by itself and adding

them instead of subtracting, before taking the square root. But it must be remembered that this only applies to a right angle triangle, so if the triangle happens to be like figure 3 it must first be made into a right angle as we have done with the dotted line.

This is also useful in finding the

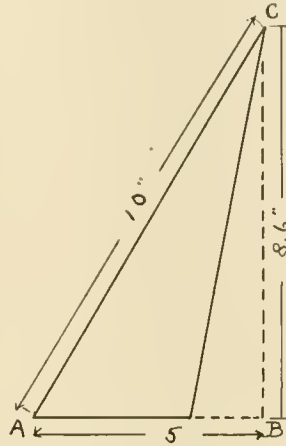

FIG. 3.

area of a triangle and while we are at as well be taken up. The area of any triangle is always one-half the longest side multiplied by the vertical height at right angles to it. This holds true in any shape of triangle unless we say, to be captious, that the equal sided triangle has no longest side, but here we take any side and multiply by the vertical height taken from that side.

In figure 1 we have the long side as one inch and found the vertical height to be .866 so we say 1 times .866, which, of course, equals .866 and we divide this by 2 which gives the area as .433 of a square inch. In figure 4 we

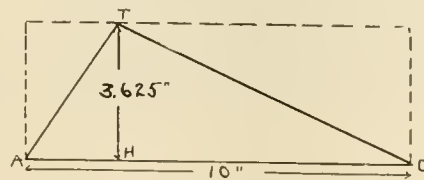

FIG. 4.

measure the long side A C, find the vertical height H T by following the rule given for finding the vertical height, and then multiply the long distance by this and divide by two. The reason for dividing by two must be evident to all, as the two triangles left out of the rectangle are together equal to the triangle we are measuring. This brings us dangerously near to geometry and as that is a terrible sounding word to most shopmen we had better stop before we learn more than we really intended at this time.

It's a wise old world that waits for the indorsement of every-day honesty on the checks of extraordinary holiness.

## Questions Answered

### AUTOMATIC STOP SIGNAL.

(10) L. D. F., Philadelphia, Pa., asks.

Is there any absolutely reliable automatic stop signal in use on our railroads? (2) If there is, who makes it and how does it operate? A—(1) Read article on Automatic Train Stopping in RAILWAY AND LOCOMOTIVE ENGINEERING for February, 1906, page 51. The Boston Elevated and the New York Subway are equipped with reliable automatic stop signals. Both of these are covered by the Kinsman patents.

(2) The Kinsman Block Signal Company make what is probably the best stop signal which we know of. The arrangement adapted for ordinary steam roads which may at times be covered with snow, is different in some details from that on the Boston Elevated or the New York Subway. The company explain that the system applicable to steam roads is such that at each signal there is a 120 ft. contact rail in shape resembling the wing rail at a frog. This contact rail is placed farther away from the running rail than a wing rail at a frog would be, and when the signal is at danger the contact rail becomes increasingly energized by an electric current similar to but more powerful than the track circuit current used for operating the visual signals. The result is that when a train attempts to pass a signal set at danger, contact arms on the locomotive carry from the contact rail sufficient current to the apparatus in the locomotive cab to stop a train wrongfully passing a signal at danger. This operation is accomplished by shutting off the motive power and applying the air brakes.

If the track is normal and the signal is at safety the contact rail is not increasingly energized and the contact made by the train in passing it produces no operative effect on the mechanism for controlling the motive power and the air brakes.

A supplementary device records the danger or safety condition as well as the integrity of the circuits of both the visual and automatic devices, thus furnishing a complete record on each trip of the condition of these circuits and the apparatus. In addition, the character of this record indicates the manner in which the engineer has performed his duties, thus protecting him against the unsubstantiated charge of improperly passing signals at danger.

### LAME ENGINE WITH WALSCHAERTS GEAR.

(11) C. J. V., Danville, Ill., asks: Let me know how to find out or to locate on which side an engine is lame with the Walschaerts valve gear? A.—The defect can be detected by observing the time and volume of the four exhausts, the same

as if the engine was equipped with any other kind of valve gear. Some engineers by putting their heads out of the cab window and observing the movement of the crosshead can tell at once on which side the defective exhaust occurs. The crosshead can be more easily watched by standing near the track while the engine is moving slowly and with the lever at the extreme end of the quadrant the exhaust should occur near the end of the piston stroke. The exact determination of the condition of the valves can only be made by a skilled machinist.

#### APPLICATION WITH CUT-OUT COCK CLOSED.

(12.) R. M. Q., Mahoningtown, Pa., writes:

I would like you to answer a few questions for me in your column of "Questions Answered," regarding air brakes. (1) With a D-5 or F-6 brake valve can an application always be made with the cut-out cock below brake valve closed? A.—When the standard brake valve cut-out cock is closed, an application cannot be made with its brake valve. The Pennsylvania road, however, uses a special brake valve cut-out cock with which, when it is closed, an application can be made if the brake valve handle is placed in emergency position. This special brake valve cut-out cock has a pipe branching from it to the emergency exhaust port of the brake valve, and when the cut-out cock is closed a port through the cock plug permits brake pipe air to flow into this pipe up to the brake valve.

#### PUMP COPPER GASKETS.

(2) To apply a new copper gasket on any air pump, is it a good plan to paint the gasket when a person wants to avoid unnecessary leaks? A.—We think a copper gasket of sufficient and even thickness all over, properly annealed, should make a tight joint without the aid of paint of any kind. However, where there are defective and uneven surfaces to contend with, paint may help to make the joint tight, but we do not think it is a good plan, as a rule, to resort to this method of preventing leaks.

#### LIFT OF AIR VALVES.

(3) What is the proper lift for air valves in the 8-inch pump? Some people have a habit of giving the discharge valves 3-32 inch, and the receiving valves  $\frac{1}{8}$  inch lift, while others give them 3-64 inch and 3-32 lift, respectively. A.—The receiving valves in an 8-inch pump should have  $\frac{1}{8}$  inch, and the discharging valves 3-32 inch lift.

#### NEGATIVE LEAD.

(13.) R. J., Waterville, Ont., writes: In reading your description of the Balanced Compounds for the Northern Pacific, in the December, 1906, issue of RAILWAY AND LOCOMOTIVE ENGINEERING,

it states that the valves are set with one-quarter inch lead, full back and front, and in speaking of this to our boys one of them said it was negative lead. I said it was not. Please say who is right. A.—You are right. "Negative lead" are the words used when valves are so set that each valve has a certain distance to travel before it opens the steam port. It opens the port after the piston has moved a certain distance at the beginning of the stroke. Positive lead or just lead, as it is called, is the amount the valve has opened the port before the piston begins its stroke. See answer to question 111 in our December, 1906, issue. Valves set blind may be said to have negative lead.

#### PISTON TRAVEL AND TIME OF RELEASE.

(14.) J. D., New York, writes: (1) On the 4-5-6-7 inches of travel of the piston, which will release first? A.—If a full service application is made, assuming that the train is short, and that there is ample main reservoir capacity and full excess pressure available, the chances are in favor of the shortest piston-travel brake releasing first, and the longest last, but the difference in time will not be much. On long trains, main reservoir capacity and excess the same as before, which will release first will depend on the location of the shortest piston, whether it is near the engine or not; if not, it will release later than the longer pistons. With partial service applications, and assuming that all triples go to release at the same instant, those having the shorter travel should return to full release a little earlier than those having the longer.

(2) Which cylinder has the most air, the long travel or the short travel? A.—With full applications, the cylinder having the longest travel will contain the most air and the lowest pressure; that having the shortest travel, the least air and the highest pressure. With partial application, there will be no difference in the quantity of air, each will contain on account of difference in travel until the point at which the shortest travel piston equalizes with the auxiliary is passed.

#### CAUSE OF BROKEN VALVE COVER.

(15.) A. P. Sydney, N. S. W., writes: An engine fitted with the 9 $\frac{1}{2}$ -in. improved pump and hauling a goods train had proceeded some twenty miles from the depot when it was discovered that the cover on the large end of the differential piston was broken. We proceeded some miles farther on to the locomotive depot, where another was obtained and put on. The train had only got a few miles away when this cover was also broken. We then managed to work the train to another locomotive depot where a cover was obtained and put on, but this cover did not last long

enough for the engine to get away with the train. What was the cause of the piston breaking the cover? A.—Very likely the lock nut on the end of the main valve stem worked loose, and unscrewed far enough to strike the main valve cylinder head before the large main valve piston closed the steam port leading around behind it, and thus prevented the forming of a cushion to bring it smoothly to rest. If the right main valve head gasket was omitted or if the cap screws were tightened up unevenly, either of these, or both combined, could assist the loose nut to break the cover.

#### CURVE MADE BY A CRANK PIN.

(16.) T. McC., Fort Wayne, Ind., writes: Take the butt end of the main rod, which is held in position by the main pin. When the wheel makes a revolution, does the crank pin make a complete circle, or an oblong circle, or something like pot hooks? A.—If you had a pencil standing out from the centre of the crank pin far enough to trace a line on a whitewashed wall as the driving wheel rolled along the track, you would find that the pencil would draw a wave-like line, something like the scalloped edge of a table mat. The curve is what is called a cycloid, or to be exact, the curve is swept out by the centre of the crank pin is a prolate cycloid. This curve is very carefully traced in the illustration on page 364 of Forney's Catechism of the Locomotive. See article on Cycloid Curves on page 64 of this issue of RAILWAY AND LOCOMOTIVE ENGINEERING.

#### LEAD OF VALVES OF LOCOMOTIVES.

(17.) R. M. Q., Mahoningtown, Pa., Should locomotives in mail service have lead of say  $\frac{1}{8}$  of an inch? I contend that they should where time is fast and stops are close together, and where you have to get away fast, which is hard to do with no lead. Am I right? A.—Yes, in a certain sense you are. The whole matter is very greatly involved in the weight of the train. If the engine handles it easily, lead such as you specify is a good thing, but if the engine is habitually worked to its full capacity, then too much lead is not beneficial.

#### STRESSES IN A GIB CRANE.

(18.) L. C. B., Covington, Ky., writes: Please explain how to figure the stress of different parts of the gib crane? A.—We expect to be able to deal with this matter in a separate article in our correspondence school in the near future. It is very difficult to answer your question properly in the limits of the Question and Answer column.

# Air Brake Department

CONDUCTED BY J. P. KELLY

## Air Brake Maintenance.

During this prosperity period the demand for cars to move freight is very urgent, and on all sides the car shortage is complained of. It is during such a period as this that railway managers find it difficult to hold cars out of service for the repairs which they should receive. Hence, when the air brakes become due for cleaning and oiling the temptation is strong to slight this important work, and to allow the brakes to run just as long as they will without attention.

It should be remembered, however, that this is not good policy, as it will surely result sooner or later in very expensive annoyances, loss of time, and possibly disastrous wrecks.

To-day many roads are hauling trains consisting of considerably more than fifty cars, and to insure the satisfactory operation of the brakes on these long trains requires that the triple valves be kept in much better condition with respect to cleaning and oiling than was formerly the case when the number of air brakes coupled was forty or less. The brake cylinders, too, need more frequent attention; they should be cleaned and properly lubricated, and their packing leather put in an air-tight condition as often as it is necessary to do so to get the desired results.

Although the time that cars can be held to do this work must necessarily be the shortest possible, proper facilities, with an adequate working force of efficient air brake men, will permit this to be done, and if done, in the end it will pay well. On level roads, it is true, brakes may be allowed to deteriorate to some extent without the bad effects being so acutely felt, but on hilly roads it is dangerous to take any chances with brakes that have been neglected. Heavy grades always exert an accelerating force on the trains that can only be neutralized by the action of the brakes, and in order that they may supply this neutralizing force they **must** be maintained in good condition. To attempt to handle heavy trains on grades, with the air brakes in any but first class condition, will result sooner or later in serious mishap.

Aside from cleaning and oiling the brakes on the car, a generous air supply on the locomotive should also be provided. A pump of sufficient capacity to supply forty cars cannot reasonably be expected to supply a train of eighty or one hundred cars.

## High Speed Brake a Life Saver.

Not much is heard of the railway employee who habitually performs his duties faithfully and satisfactorily. He is never required to walk the carpet, and somehow he is lost sight of, as it is expected of him, as a matter of course, that he will perform all duties well.

It seems to us that the high speed brake stands much in the same position; constantly performing, as it does, its duties in a faithful and a highly efficient manner, we are apt to forget about its good qualities. During the recent epidemic of disastrous railway wrecks, the high speed brake, because of the circumstances surrounding the most of them, did not have a chance to show what it could do, but in one of these wrecks it had about 650 to work in.

## Electrical Terms.

On account of the electrical apparatus that is used in connection with air brakes on electric locomotives and trains, it will be necessary from time to time to use electrical terms in articles describing them, and the following, therefore, will be found useful.

**VOLT**, the unit of electro motive force, or pressure.

**AMPERE**, the unit of electric current.

**OHM**, the unit of resistance to flow of electric current.

To get a tangible idea of the meaning of these terms, let us consider the case of water flowing from a given height, or head, as it is termed, to a lower level, something we are all familiar with. We know that a column of

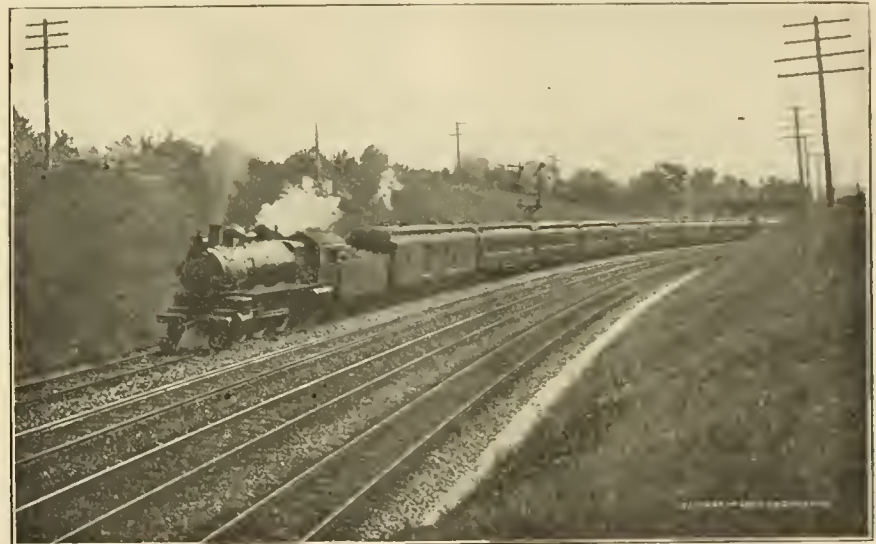

MODERN TRAVEL—FOUR-TRACK, BLOCK SIGNALLED ROAD. HIGH SPEED BRAKE ON TRAIN.

In this short distance, it was able to reduce the speed of a double headed fast passenger train from 60 miles per hour down to a rate of speed so low that when collision occurred the train did not strike with sufficient force to hurt or injure a single passenger or seriously damage a car in the train. The wreck, however, took fire, and all of the passenger coaches but one were consumed by the flames.

It has been said that during the present time, the railroads cannot supply cars to haul the freight offered them, but in collisions they have cars to burn. In the case which we cite it was true, there were cars to burn, but happily no passengers, and for the latter the Westinghouse high speed brake should receive credit.

water of a given height has a pressure corresponding to this height; for example, if we had a cylinder, full of water, the area of whose end was one square foot, and whose length was thirty-four feet, it would contain thirty-four cubic feet of water. If this cylinder stands upon its end, or vertically, this quantity of water would cause a total pressure upon its base of 2116.8 pounds, or 14.7 pounds per square inch.

If an opening were made at the base, the water would flow out at a rate corresponding to the head, or pressure; and if the head is maintained constant, the rate of flow of the water, or the quantity escaping at the opening, will be constant per unit of time. If instead of a simple opening at the bottom of the cylinder we should have a pipe con-

nected to it that led to a distant point, through which to conduct the discharge to some desired place, we should have the same height, or head, and, therefore, the same pressure, but on account of the resistance which the friction of the interior of the pipe would offer to the flow of the water, the quantity discharged at the end would not be so

or electro motive force, when we know the rate of the current and the amount of resistance.

If we know the electro motive force and the resistance, then the expression

$$C = \frac{E}{R}$$

will enable us to determine the amperes of current.

If we know the voltage and the current, then the expression

$$R = \frac{E}{C}$$

will enable us to find the resistance in ohms.

We shall illustrate these expressions with practical examples: It is known that a piece of copper wire 1/16 of an inch in diameter, one mile long, has a resistance of 13.59 ohms, when the temperature is about 60 degrees Fahrenheit. What will be the electromotive force required to produce a current of 120 amperes per second in a wire two miles in length, 1/8 of an inch in diameter, at a temperature of 60 degrees F.?

Remembering that the resistance to flow of electricity varies directly as the length, and inversely as the sectional area, of the wire, we first find what the total resistance will be. This is done by multiplying the resistance, as given above for a wire 1/16 of an inch in diameter, by 2, and dividing the result by the sectional area;  $13.59 \times 2 = 27.18$  will be the resistance in ohms for two miles of 1/16-inch wire; this divided by the sectional area of the 1/8-inch wire or by 4 gives 6.8 ohms as the resistance. Therefore, the electromotive force required to maintain a current of 120 amperes per second equals  $E = C R = 120 \times 6.8 = 816$  volts.

With a current of 816 volts and a resistance of 6.8 ohms, we find the amperes to equal

$$C = \frac{E}{R} = \frac{816}{6.8} = 120 \text{ amperes.}$$

With an electro motive force of 816 volts and a current of 120 amperes, we find the resistance

$$R = \frac{E}{C} = \frac{816}{120} = 6.8 \text{ ohms.}$$

The temperature of the wire affects the resistance; the higher it is, the greater the resistance.

The volt is that electrical pressure required to maintain a current of one ampere against a resistance of one ohm. The ampere is that current which a

pressure of one volt can maintain against a resistance of one ohm.

The ohm is that resistance to flow of electrical current at one volt which will limit the current to one ampere per second.

**Electric Air Compressor, Type D-E-G.**

Many locomotive men are no doubt somewhat unfamiliar with the electric air compressor, such as is now gradually coming into heavy railroad service, although this type of compressor has been in use in traction brake service for a number of years, and they may be, for this reason, inclined to look upon it as an intricate piece of machinery, something very difficult to understand. That this is not so, after all, will readily be perceived from a casual glance at the illustrations, Figs. 1 to 4 inclusive, which show its construction. Also, a careful reading of this article will show that it is a much pleasanter piece of mechanism to operate than the steam driven locomotive air pump.

From Figs. 1 and 2, which are section and plans views of the compressor and the motor, it may be seen that the compressor part consists of two air cylinders, with air pistons in each. These pistons are driven by a crank and connecting rod, turning in the direction indicated by the arrow, the crank receiving its power through a gear wheel and pinion, clearly shown in Fig. 2, from the electric motor, which of course is turned by electricity, supplied to it by a wire leading from the trolley.

The small pinion is attached to the end of the motor shaft and it meshes into

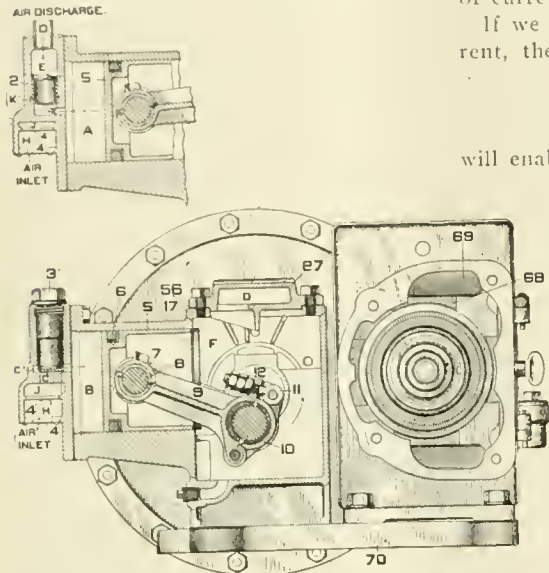

FIG. 1. CROSS SECTION SHOWING PUMP PISTON.

great as at the opening made close to the base of the column, which allowed it to discharge freely into the atmosphere. The amount of decrease in the quantity discharged through the pipe will depend directly on the amount of resistance the interior surfaces of the pipe offers to the flow. This resistance will increase with the length, and decrease with increase of diameter and sectional area of the pipe.

We may now consider the volt in electricity as corresponding to the head, or pressure in the water column; the ampere as corresponding to the quantity of water that flows through the pipe, and the ohm as corresponding to the frictional resistance which the pipe offers to the flow of the water.

Therefore, when we speak of volts, we mean electrical pressure; of amperes, we mean electrical current; and of ohms, we mean the electrical resistance.

Instead of pipes to conduct electricity, wires are used; and for any given voltage, the quantity that will flow through a wire will depend directly upon its length, and inversely upon the square of its diameter or its sectional area.

If we let E represent electro motive force in volts; C represent electric current in amperes per second, and R represent the resistance to flow of electricity in ohms, the expression

$$E = C R$$

will enable us to determine the voltage,

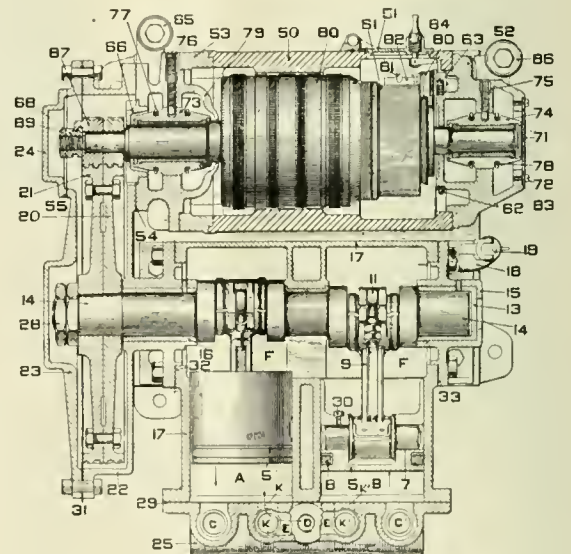

FIG. 2. PLAN OF ELECTRIC AIR PUMP.

the large gear wheel on the end of the air piston crank shaft. When the switch is opened, that allows the electric current to flow to the motor, the latter begins to turn and the turning power is transmitted through the gearing to the piston cranks rods and the air pistons, causing



the latter to move back and forth through their cylinders. The air cylinders and pistons are single acting, that is, they draw in air, and compress it, in one end only.

The end view, Fig. 3, shows the air valves and discharge connection. There are two of these for each cylinder, one receiving and one discharging, and an air discharge pipe, which carries the compressed air from both cylinders to the main reservoir, the same as is done with the steam driven air pump.

The operation in the air end is simple. As the piston moves away from the end of its cylinder it creates a vacuum behind it, the outside atmosphere raises the air inlet valves 1 and flows into the cylinder to fill it. On the return stroke this air is compressed and driven out through the discharge valves 2 into the discharge pipe and the main reservoir.

These air valves are made of drawn steel tubing, are light, seat by gravity, and are easily removable.

The suction valves are accessible by removing cap nuts 3 and the discharge valves by removing cap nuts 26. All four valves may be quickly and simultaneously removed for repairs or replacement by taking off the cylinder head.

The pistons 5 are fitted with rings 6, which are accurately ground to their respective pistons and cylinders. Therefore, when it is necessary to take a pump apart to repair it, care should be taken upon re-assembling to keep the packing rings with their pistons.

Glancing at Fig. 1 it will be noticed that the center line of the air cylinders is a little above the center of the crank shaft. This is so that the connecting rod will bring a straight thrust upon the piston when the latter is making its compression stroke, and this greatly reduces the wear on the cylinders. The pistons should always run in a clockwise direction.

The lubrication of the motor and of the compressor is an important matter, and care should be exercised to see that all bearings get sufficient oil. To lubricate the compressor end, remove the cap 19 and pour oil into the crank case, which is dust proof, until it will hold no more. This oil goes through the fitting 18, which will act as a gauge to tell when enough has been poured in. To oil the motor shafts and gears, remove the caps 65 and pour in oil until full. The compressor will distribute the oil itself to all its bearings.

The brush holders are shown in Fig. 4 and they belong to the motor end, which will be described in another article.

From the foregoing, it will be noticed that there are no piston rods to keep packed or oil cups that need attention two or three times daily during the trip.

### Railroad Employees in the U. S.

According to the Interstate Commerce Commission the reported number of persons on the pay rolls of the railways in

the United States on June 30, 1905, was 1,382,199, which is equivalent to an average of 637 employees per 100 miles of line. These figures show an increase in the number of employees as compared with the year 1901 of 86,075, or 26 per 100 miles

classes of employees for a series of years, and also the aggregate amount of compensation stated for the several classes. The total amount of wages and salaries reported as paid to employees during the year ending June 30, 1905, was \$839,944,680.

### Timber Preservative.

An interesting method of applying a preservative to railway sleepers and timber is described in *L'Industrie Electrique* of Paris. The process consists of the artificial metallization of the pores of the wood, the metal being deposited electrolytically. In brief, the method requires, first, the application of a solution of some salt—sulphate of copper, for example—by placing the wood immersed in the solution in a closed chamber and subjecting it to pressure. The wood is thus thoroughly impregnated with the solution. It is then taken out and piled up in layers in a concrete reservoir. The first layer of timber is immersed in the same copper sulphate solution, and also rests on a layer of jute or other fibrous material, which is supported by an electrode made of woven strands of copper. Similar elec-

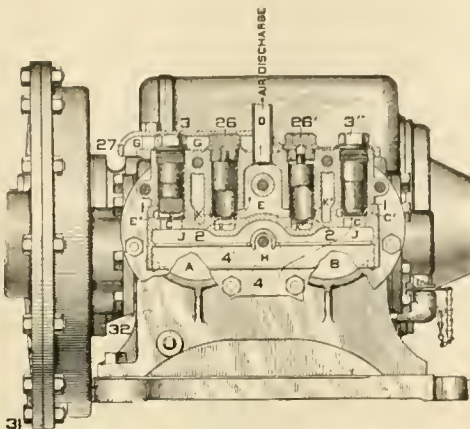

FIG. 3. END VIEW OF PUMP.

of line. Of the employees 54,817 were enginemen, 57,892 firemen, 41,061 conductors, and 111,405 were other trainmen. There were 45,532 switch tenders, crossing tenders, and watchmen. The total



SWITCHING "PUG" ON THE NEW HAVEN.

number of railway employees, disregarding a small number not assigned, was apportioned among the four general divisions of railway employment as follows: For general administration, 54,141; for

trodes are placed between each layer of timber as they are piled up to the desired height. Alternate electrodes are then connected to the opposite poles of an alternating current supply, and the current is allowed to pass. The action is said to decompose the solution and set free metallic copper in the pores of the wood. Besides the preservative action in thus closing the pores, it is said that a certain amount of copper sulphate is permanently retained in the pores, giving an additional and a decided preservative effect.—*London Standard*.

On the Bengal-Nagpur Railway in India, a number of carriages have been fitted with an experimental device for stopping the train. A passenger in danger can, by tearing the paper covering of a small box, get at a knob which when pressed applies the brakes.

In Spain no one enters or leaves a railway carriage without bowing politely to the occupants.—*N. Y. Globe*.

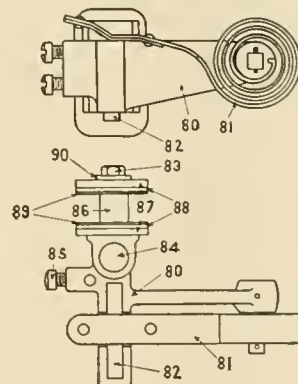

FIG. 4. BRUSH HOLDER.

maintenance of way and structures, 448,370; for maintenance of equipment, 281,000, and for conducting transportation, 595,456.

The report includes summaries showing the average daily compensation of 18

# Electrical Department

## Electro-Magnetism.

BY ROGER ATKINSON.

In experiments made by the philosopher Oersted it was shown that a wire carrying a current is surrounded by a magnetic field which, on account of its action on a magnet, has been called a rotative magnetic field. It should be clearly understood that this magnetic force commences to develop as soon as the current begins to flow, increasing in strength as the current increases, and is propagated from the wire like light from the sun. The speed of formation of this magnetic field is the same as the speed of light, namely, about 185,000 miles per second, as predicted by Faraday and proved by Clerk Maxwell. Consequently when the current ceases to flow this magnetic field ceases to exist, not by diminution of distance propelled, but by ceasing to be started from the wire or from the inside. Thus, so long as the current is constant, the magnetic field is constant and is equal all along the wire.

Now it was also found by Oersted that from the power of this magnetic field it is possible to reverse the operation and to develop electric current in another wire if this second wire was a part of a circuit. Thus, let A be a wire through which a current can be sent or stopped as desired by closing or opening a switch (this wire will be called the first or primary wire) and let a second wire B, which forms part of an-

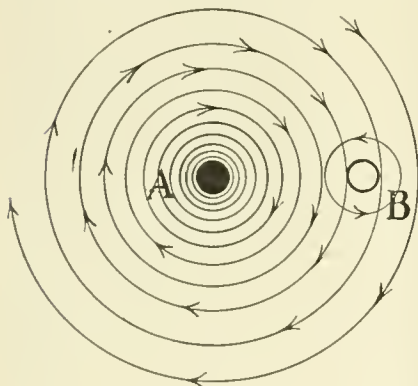

FIG. 2. PRIMARY ROTATION "CLOCKWISE," SECONDARY IS THE REVERSE.

other circuit, be laid closely parallel to wire A for some distance (this is called the secondary wire). Now if a current be started in the primary A, the formation or throwing out of the magnetic field round A will cause a current in the secondary B, but in the *opposite direction* to the current in A, and only

while the current A is increasing to its full strength, so that when there is no further increase in the primary current A, and therefore no increase in the power of the magnetic field, there is no current in the secondary wire B. If now the current in A be suddenly

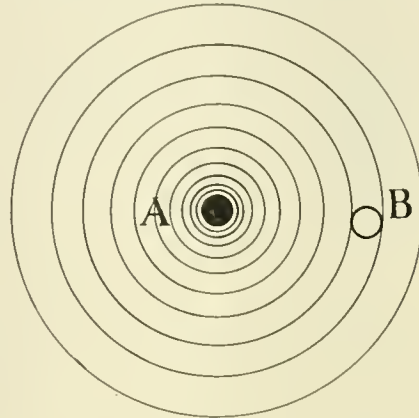

FIG. 1. MAGNETIC FIELD SURROUNDING A WIRE.

stopped the magnetic field round A at once ceases, then the falling away of the magnetic condition will produce a current in the secondary wire B, but in the *same direction* as the primary current A. These currents in the secondary wire B are only momentary in either direction and consequently the impulses can be reproduced as quickly as the connection in A can be made or broken. Thus while the current in A is continuous as to direction, but intermittent as to time, the secondary current in B will be alternating in direction. This result appears to be due to the unbalanced state of the magnetic field round about the secondary wire B, while the field is being formed or dispersed, and when more intense on one side than the other causes magnetic rotation about B, with the result that a current is formed in it.

Taking the former figure and supposing the current in A to be from the observer, then the rotation of the field will be "clockwise," as shown by the arrows. Now when the magnetic field infringes upon wire B it causes rotation about B in a "counterclockwise" direction, with the consequent formation of a current in B *towards* the observer, so long as the magnetic field is stronger inside than the other. When the current in A reaches its full strength there is no further change in the magnetic field and the production of current in the secondary wire B ceases. On the other hand, when the

current ceases in A and the formation of the magnetic field falls off, it diminishes from the inside first, and the field is stronger outside of B than inside, with the result that there is a rotation about B in a "clockwise" direction, which produces a momentary current in B *from* the observer.

It will therefore be observed that if a wire which forms part of a circuit is located in a magnetic field which is changing in intensity across the wire (not lengthwise) it will produce current in that wire in proportion to the difference in intensity on the opposite sides of the wire. In general electrical machinery this result is obtained from the same causes in another way. Let A be a primary wire carrying a continuous current *from* the observer and constant in force, then the magnetic field will be constant and decreases uniformly in intensity in proportion to the distance from the wire A. Now if the wire B of the secondary circuit is suddenly pushed laterally, as shown by the arrow, into the magnetic field (parallel or nearly so to wire A) the intensity of the field is increased ahead of wire B and decreased behind it, so that it sets up a rotation round B in a "counterclockwise" direction and a current *towards* the observer is generated. Then if wire B is pulled suddenly out again the opposite action

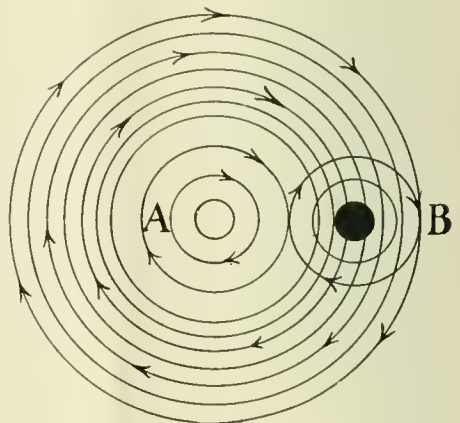

FIG. 3. PRIMARY IS "CLOCKWISE," SECONDARY IN SAME DIRECTION.

takes place and a current *from* the observer is generated.

If this is done rapidly an alternating current is generated in the secondary wire B from a constant continuous current in the primary A, exactly as was formerly shown to be the case when both wires were stationary but

the primary current in A was an interrupted one. A clear idea of the magnetic eddy round wire B may be got from the mechanical parallel obtained by passing a stick or rod across the path of rain drops in a storm, when the drops impinge upon the advancing side of the rod they adhere to it by cohesion to some extent and their velocity impels the water round the rod to form a water eddy in the same form as the rotating field about wire B. The current set up in the secondary circuit B in these several cases is called an induced current of electricity and the electrical phenomenon is spoken of as induction.

**Fuses in Electric Circuits.**

The fuse in an electric circuit is, in a certain sense, something like a safety valve on a boiler. When the normal pressure of the boiler is exceeded the safety valve opens and relieves the pressure. The electric fuse also "lets go" when the normal current in the wire is exceeded, but here the similarity between fuse and safety valve ends. The safety valve relieves pressure and is good any number of times, whereas the safety fuse when once "blown" is destroyed and a new fuse must be applied.

The material of which a fuse is made is very frequently an alloy of lead and tin. Bismuth is added when it is desired to still further lower the melting point. In this, the cut out, as it is sometimes called, is very like the fusible plug in a locomotive firebox, for when the fusible plug has been melted out, a new one has to be put in. The capacity of an electric fuse is determined by its cross section; the larger the sectional area, other things being equal, the greater the current carried.

The fuse is at all times an integral portion of the circuit and all the current which flows over the wire goes over the fuse. It is composed of metal which offers a much higher resistance to the passage of the current than the rest of the wire, and this resistance generates heat under ordinary circumstances. A properly made fuse is adequate to the demands made on it, but when an overload occurs the extra resistance of the fuse produces heat enough to melt it and so open the circuit. It is commonly said that a chain is no stronger than its weakest link, and in electrical work the fuse is purposely made such a link in the circuit. Thus the fuse is a safety device pure and simple.

Fuses are generally marked with the number of amperes which they will carry with safety, but there is generally a certain margin allowed, there being usually a 20 per cent overload permitted above what the fuse is marked for, so

that a slight fluctuation above the normal will not blow the fuse. Fuses are often made of several separate small wires, and are bound with copper at the ends, and these fit into convenient receptacles. The removal of a fuse, whether blown or not, breaks the circuit completely.

**Heat Electrically Produced.**

A very interesting experiment which reveals the action of an electric current and the generation of heat was many years ago performed by Tyndall in one of his public lectures. It should be remembered the grand discovery made by Faraday was that when a conductor of electricity is set in motion between the poles of a magnet a current of electricity flows in the conductor. This is the fundamental principle of the dynamo as we know it today.

Tyndall's experiment consisted in having a U-shaped electro-magnet set up on a stand with a pair of loose pole pieces,

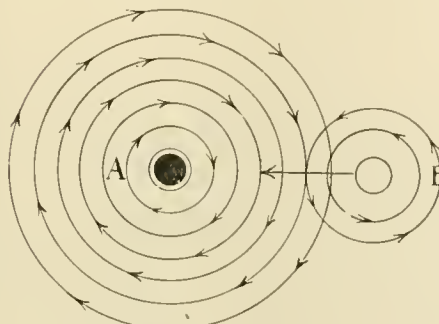

FIG. 4. PRIMARY CLOCKWISE, SECONDARY COUNTER-CLOCKWISE.

one on each end of the U-magnet. Between the poles he placed an ordinary silver medal, such as a soldier might wear, and suspended it by a twisted string. In order to make the revolving motion of the medal apparent as the string unwound, a four-sided mirror was placed on the string and a beam of light played on the mirror; the beam, striking the revolving mirror caused a series of illuminated patches of light to follow one another on wall and ceiling while the mirror turned, as the string unwound.

The moment a current of electricity was switched on, the space between the pole pieces became, as Tyndall describes it, just as if it were filled with a viscous liquid. The revolving medal struggled to keep on turning and then stood still with the string but half unwound as if it had been immersed in a pot of treacle instead of hanging freely in the air. As soon as the electric current was interrupted, the influence of the magnets disappeared, and the medal resumed its spinning motion.

A further modification of this experiment was made by placing between the pole pieces an upright hollow cylinder of copper, filled with a hard but easily melted alloy, something like the fusible plug in

the crown sheet of a locomotive. This copper cylinder was made to spin round by the use of an ordinary whirling table, turned by hand. The copper cylinder placed between the poles of the magnet contained solid metal. It was rapidly spun round, without wobbling and hardly disturbed the air around it. As soon as the electric current was permitted to flow through the magnet the copper cylinder offered considerable resistance to being turned, and when forcibly made to rotate by vigorous action imparted to the whirling table, the cylinder gradually became hot and at last the fusible core melted and splashed out of the top of the cylinder, and when the whirling ceased the white metal was poured out of the copper cylinder in liquid form.

These experiments were made with medal and cylinder surrounded by the free air of the room and neither of them was in contact with the electro-magnet or any part of the apparatus. They occupied the space between the pole pieces, and by their arrested motion and the generation of heat made visible the effect which may be produced by the silent but potent influence of the electric current.

**Railway Automobiles.**

Railway automobiles are beginning to be considerably used in Europe—(1) as early and late postal trains, (2) on branch lines and others where passengers are few, (3) on trunk lines where it is often difficult to secure convenient secondary trains, (4) in industrial centres and city suburbs. Furthermore, the automobile railway train can be attached for a certain distance to an express and detached at the station where the road branches.

There is an economy in the personnel of the train, in the expense of traction, in material, capital and maintenance, and there is additional traffic because of the increased number of stations made possible by the facility of starting and stopping. Up to the present time the carriages constructed are steam and electric.

The Belgian State Railways has carriages 46 feet long, weighing 50 tons, and having a seating capacity of 53 passengers. The ordinary speed of these trains is 10 miles an hour, although they can be pushed to 30. Two men handle a train.

The Russian State Railway employs ten steam coaches which are really two stories. Three men are used, and the speed averages about 14 miles an hour. They burn naphtha. The Northern Railway of France has postal steam autos, with room for 12 people in the back of each coach. The Italian Mediterranean Railway has autos on a line from Milan to Monza, the carriages each having a seating capacity of 90 passengers, and the trains traveling at 27 miles an hour.

### Motor Car No. 8 on the U. P.

The car body and trucks of Motor Car No. 8 on the Union Pacific, which we here illustrate, are similar in design to those of Motor Car No. 7. The windows of this car are round and equipped with rubber gasket seats, making them absolutely impervious to water, wind and dust. The most advantageous feature of the round window is in the increased strength of the car, the side being in reality a plate girder, the depth being from the car roof to the car sill. The side door entrance adds materially to the comfort of the passengers without in any way weakening the strength of car frame. This door permits of an inside step being used, which avoids the trouble due to the accumulation of ice and snow in the winter, which is usually experienced on outside car steps.

Very few changes have been made in the mechanical transmission on the front trucks from that used on the previous

ple, and the economy in the consumption of gasoline and reduced duty on the transmission mechanism is such that the practicability of these cars for every day heavy service is certainly demonstrated. The car weighs 61,000 lbs.

### High Steam Pressures.

A short time ago Prof. W. F. M. Goss read a paper on "High Steam Pressures in Locomotive Service" before the Western Railway Club. The paper was in substance the results of a series of tests made last summer at Purdue University to determine the value of high steam pressure in locomotive service. The tests included a series of runs in which the average pressures were 240, 220, 200, 180, 160 and 120 lbs. The locomotive used was the one known at the university as "Schenectady No. 2."

The work with the experimental locomotive has shown that those difficulties

done with the same grade of oil which was satisfactory at the lower pressures. It was also found that with increase of pressure any leakage from boiler or cylinders became more serious in its effect on performance. Notwithstanding the care taken to prevent leaks, it was impossible under high pressures to avoid all leakage.

The effect of different boiler pressures upon boiler performance showed that the evaporative efficiency of a locomotive boiler is but slightly affected by changes in pressure, between the limits of 120 and 240 lbs. Changes in steam pressure between these limits will produce an effect upon the efficiency of the boiler which will be less than one-half pound of water per pound of coal. It is safe to conclude that changes of no more than 40 or 50 lbs. in pressure will produce no measurable effect upon the evaporative efficiency of the modern locomotive boiler. The effect of different pressures on smoke box temperatures was such that it was found that when the smoke box temperature falls between the limits of 500° and 850° F., the lower limit it agrees with a rate of evaporation of 4 lbs. per foot of heating surface per hour, and the higher temperature with a rate of 14 lbs. per foot of heating surface per hour. Smoke box temperature is so slightly affected by changes in steam pressure as to make negligible the influences of such changes in pressure for all ordinary ranges.

The performance of the engine, taken to mean the steam used to produce one horse power per hour, was shown by a curve plotted from all the tests run under the several pressures employed. This curve showed that the variation in performance for all conditions which are possible with a wide open throttle scarcely exceeded five pounds. The corresponding consumption of Youghiogheny lump coal for the various pressures showed that at 240 lbs. the coal consumption per horse power per hour was 3.31 lbs., at 220 lbs. it was 3.35, at 200 lbs. 3.40, at 180 lbs. 3.46, at 160 lbs. 3.53, at 140 lbs. 3.67, at 120 lbs. 3.84 pounds of coal. Increasing the pressure from 120 to 140 lbs. resulted in a fuel saving from of 4.4 per cent, while a similar increase from 220 to 240 lbs. in steam pressure resulted in a saving of only 1.2 per cent. This shows the diminishing value of fuel saving which results from a given increment of pressure as the scale of pressures is ascended.

Among the summary of conclusions given by Professor Goss, the following statements may be mentioned. It appears that under service conditions the improvement in performance with increase of pressure depends upon the degree of perfection attending the maintenance of the locomotives. The results set forth assume a high order of maintenance. If this is lacking, it may easily happen that the saving which is anticipated through the adoption of higher pressures will entirely

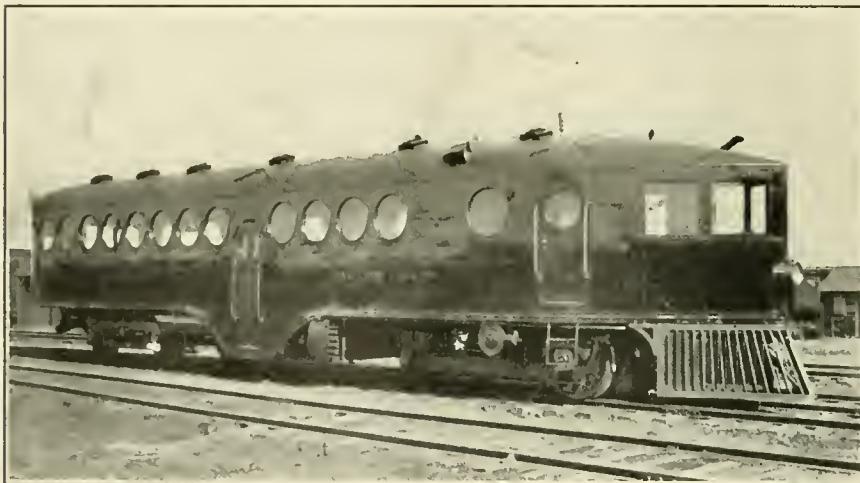

NEWEST UNION PACIFIC GASOLINE MOTOR CAR.

cars, except to substitute steel gears in place of bronze. The engine proper was built in Omaha shop, of special design; 10 by 12 cylinders with jump spark ignition and especially designed with liberal bracing and well proportioned parts to avoid a possible chance of breakdown or failure. The engine develops as high as 230 h.p., and handles the car with great ease.

A remarkable advantage gained in this engine is that the car speed is almost entirely controlled by the throttle, the same as a locomotive; even on grades the speed of the car can be varied from 3 to 70 miles an hour by means of throttle and spark levers only, or it can be started on what is known as high speed. The engine is direct connected to the axle, although it is preferable to use the gears in putting the car in motion, but after once in motion the gears are thrown out and the speed of the car entirely controlled by the speed of the engine. This makes the operation of the car very sim-

which in locomotive operation are usually ascribed to bad water increase rapidly as the steam pressure is increased. The water supply at Purdue contains a considerable amount of magnesia and carbonate of lime. With low pressures there was no great difficulty in washing out practically all the sediment. When 200 lbs. pressure came to be used the services of a boilermaker were frequently called into requisition. In operating under 240 lbs. the temperature of water delivered by the injector was so high that the scale was deposited in the check valve, in the delivery pipe and in the delivery tube of the injector. With this pressure the injector often failed after having been worked for two hours. At last a new source of water supply was employed, by which practically distilled water was delivered to the boiler.

The tests developed no serious difficulties in the lubrication of the valves and pistons under 240 lbs., though with this high pressure lubrication could not be

disappear, and also that the difficulties to be met in maintenance, both of boiler and cylinders, increase with increase of pressure.

The results supply an accurate measure by which to determine the advantage of increasing the capacity of a boiler. For the development of a given power, any increase in boiler capacity brings its return in improved performance without adding to the cost of maintenance, or opening any new avenues for incidental losses. As a means of improvement, it is more certain than that which is offered by increase of pressure. As the scale of pressure is ascended, an opportunity to further increase the weight of a locomotive should in many cases find expression in the design of a boiler of increased capacity rather than in one for higher

#### Baldwin Engines for Italy.

The Baldwin Locomotive Works have recently completed twenty locomotives for the Italian Government Railways. Half the number are of the consolidation type with single expansion cylinders and half of the ten-wheel type with balanced compound cylinders. The principal features of the 4-6-0 engine are shown in the accompanying illustration. As far as the general design is concerned, these locomotives closely follow American practice. A number of details, however, have been modified to suit the railroad company's designs. The cabs are steel of the canopy type. That is, the cabs do not have sides and windows as we have them in this country, the climate of Italy being less severe than ours.

The engine is a balanced compound

tender the wheel base is in all 55 ft. 6 ins. The weight on the drivers is estimated at 99,000 lbs., while the front truck carries 47,000 lbs., making a total of 146,000 lbs. When the weight of the tender is added the whole becomes 262,000 lbs.

A screw reverse mechanism is used. The special equipment includes Friedmann injectors, English Westinghouse air brakes and "Italian type" Coale muffled safety valves. Whitworth standard threads are used for all bolts and nuts. The screw couplers, drawhooks and spring buffers conform to designs furnished by the railroad company. All the driving-wheel centres are of cast steel, with tires held by retaining rings. The engine truck and tender wheels are of solid rolled steel. The rims are thick enough to enable tires to be shrunk on when the diameters

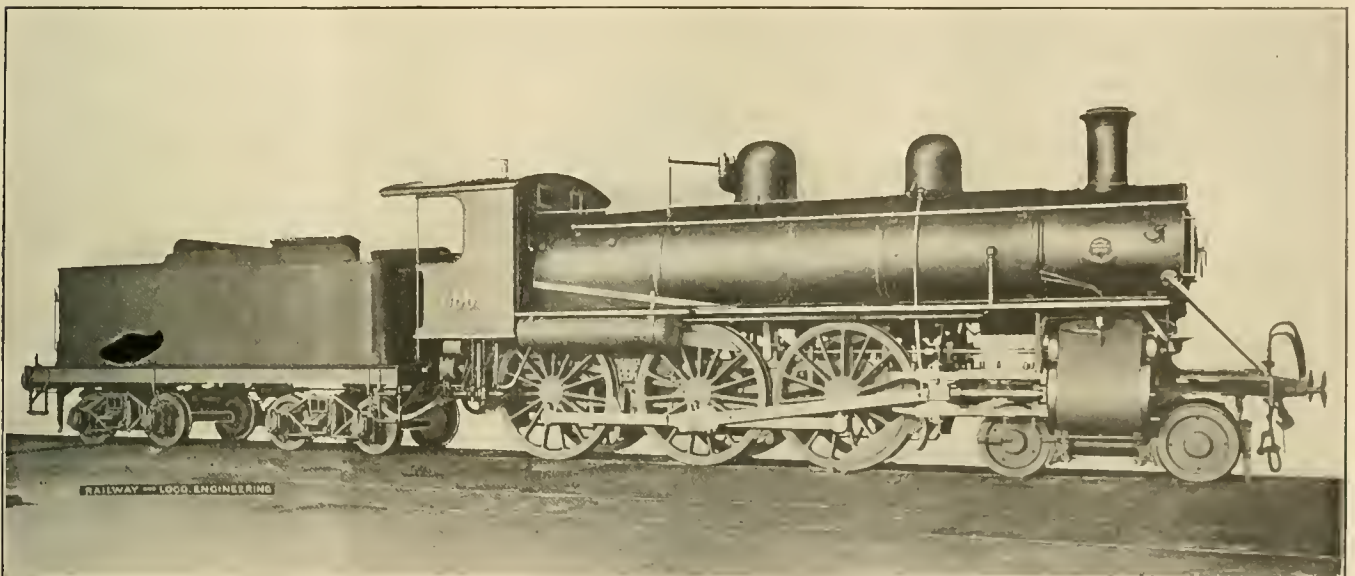

BALDWIN 4-6-0 ENGINE FOR THE ITALIAN GOVERNMENT.

pressure. Assuming 180 lbs. pressure to have been accepted as standard and assuming the maintenance to be of the highest order, it will be found good practice to utilize any allowable increase in weight by providing a larger boiler rather than by providing a stronger boiler to permit higher pressures.

Wherever the maintenance is not of the highest order, the standard running pressures should be below 180 lbs. Wherever the water which must be used in boilers contains foaming or scale-making admixtures, the best results are likely to be secured by fixing the pressure below the limit of 180 lbs.

A simple locomotive using saturated steam will render good and efficient service when running pressure is as low as 160 lbs.; under most favorable conditions no argument is to be found in the economical performance of a machine which can justify the use of pressures greater than 200 lbs.

with cylinders of different strokes. The high pressure cylinders are 15½x24 ins. and the low pressure cylinders are 25x26 ins. The driving wheels are 72 ins. in diameter. The H.P. pistons drive on the crank axle of the leading pair with comparatively short connecting rods, and the pistons of the L.P. cylinders, which are outside, drive on the centre pair.

The ratio of the cylinder volumes is 1 to 2.82. Apart from the difference in strokes, the cylinders are similar to those used on previous balanced compound locomotives built by the Baldwin Locomotive Works. All four guides are braced by one guide bearer. The crank axle is of the Z form, forged in one piece. The valves are of the piston type and are actuated by Stephenson Link motion of the indirect kind. The engine frames are of cast steel of the usual bar type. All the wheels are flanged. The driving wheel base is 13 ft. 6 ins. The total engine wheel base is 26 ft. 9 ins. and with

have become sufficiently reduced by wear. The engines are fitted with steam heat equipment.

The boiler is of the straight top type, having narrow fire box. Five locomotives have fire boxes made of copper, while steel is used in the remainder. The fire door opening is formed with a cast steel ring, to which both the inside and outside sheets are riveted. The grates are of the usual rocking type, with drop plates in front. The heating surface is 2,168 sq. ft. in all, made up of 150 in the fire box and 2,018 in the flues. These are 250 in number and 15 ft. 6 ins. long. The grate area is 33¼ sq. ft.

The tenders are of the usual type, having U-shaped tanks and frames built of 10-in. steel channels. The water capacity is 5,280 U. S. gallons and the tank carries 6 tons of coal. The engines, though American in many details, nevertheless have a foreign appearance, which is emphasized by the absence of a headlight,

pilot, bell and cab windows. Some of the principal dimensions are appended for reference:

Gauge, 4 ft. 9 ins.  
 Boiler—Diameter, 60 ins.; thickness of sheets,  $\frac{5}{8}$  in.; working pressure, 200 lbs.; fuel, coal and briquettes; staying, radial.  
 Firebox—Length, 114  $\frac{3}{16}$  ins.; width, 42  $\frac{3}{4}$  ins.; depth, front 69  $\frac{3}{4}$  ins., back 57  $\frac{1}{4}$  ins.; thickness of sheets, sides  $\frac{5}{16}$  in., back  $\frac{5}{16}$  in., crown  $\frac{3}{8}$  in., tube  $\frac{1}{2}$  in.; water space, front 4 ins., sides 3 ins., back 3 ins.  
 Driving Wheels—Diameter outside, 72.83 ins.; journals, main, 9x10 ins., others 8  $\frac{1}{2}$ x9  $\frac{7}{8}$  ins.  
 Engine Truck Wheels—Front, diameter, 34 ins.; journals, 5  $\frac{1}{2}$ x10 ins.  
 Tender—Journals, 5x9 ins.  
 Service—Passenger.

### Shop Kink Prevents Kinks.

The new erecting shop which the American Locomotive Company are putting up at Schenectady is a very modern affair and has many good points. One of them is an air hose connection at each pit which provides an easy way of making the attachment, and at the same time prevents the hose

thus supplied to the various pneumatic tools which are now part and parcel of the modern erecting shop equipment.

The lid of the box is flush with the floor and made in two pieces hinged at the ends with the parting in the middle, which is like the way some people wear their hair. The valves in the box are out of harm's way and are not therefore liable to be struck by anything or accidentally turned on or off. The box does not readily fill up with rubbish, as the lid is always on, and the bugle-shaped openings through which the hose pipes come up, present a smooth curved surface for the hose to lie against no matter how it is dragged about the floor. The whole arrangement is neat and handy and the hose cannot kink or fold over so as to restrict the free flow of air, and the connection does not get a straight pull when the hose is carried about, and so

in starting. This arrangement is usually spoken of as the system of accelerating grades, as it enables stops and starts to be quickly made. The trains are made up of motor and trailing cars like those in the New York subway. The fares vary from two to eight cents, and the run of nearly ten miles is to be made, including twenty stops, in thirty-seven minutes. The headway will be 1  $\frac{1}{2}$  minutes. The stations are equipped with elevators, and in one of them there has been installed a travelling spiral platform moving at a speed of 100 ft. per minute.

In the matter of ventilation the requisite change of air is secured by the use of nineteen fans, each 5 ft. 6 ins. in diameter. The road is equipped with automatic block signals. Each block contains an automatic stop by means of which any train running past a signal set at danger is halted by the setting of the brakes. The signals are equipped with long-burning lamps which run a week without attention. For a short distance at its western end the line runs on the surface, and here the so-called fog signals used in Great Britain are installed by means of which a signal set at danger automatically places a torpedo on the track.

The existing railways of London, underground and surface, it is estimated, carry over 600,000,000 persons yearly, of which the underground lines accommodate 258,000,000. There are nearly six hundred railway stations in Greater London, and into the trunk-line stations alone there pour annually more than 300,000,000 passengers.

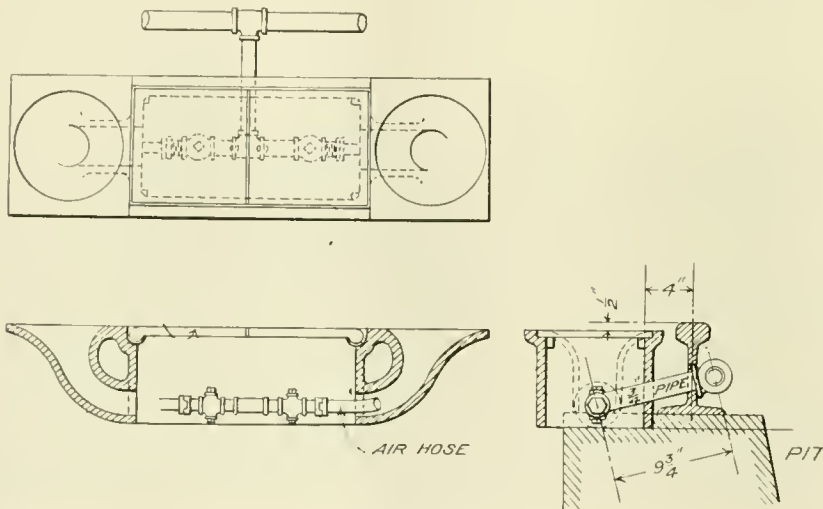

AIR HOSE CONNECTION FOR SHOP FLOOR.

pipe from becoming kinked or folding back on itself.

The floor is concrete and just outside the pit rails there is a casting set permanently into the concrete, and the top of this casting is flush with the floor. The casting is really a box with a lid and two bugle-shaped apertures at each end. The pipe conveying air is run along the inside of each pit rail so that it can be easily got at for repairs or renewal.

At the end of the pit this pipe is fitted with a Tee and a branch comes off from the Tee and passes through a hole cut in the pit rail and leads into the cast iron box with the bugle ends. In this box there is another Tee and two branches lead off from it, each branch supplied with a valve for turning on or shutting off the air. In each of the valves a short pipe nipple is inserted and to this the hose connection is made. The hose comes up through the bugle ends of the box and air is

the strain on it is never very heavy, and it is willing to show its appreciation of this kind of treatment by lasting a long time in good shape.

### London Underground.

A new underground two-track railway, the Great Northern, Piccadilly and Brompton, has recently been opened in London. It is the longest tube railway in the metropolis, being 9.75 miles in length. The depth of the tunnels, which are separate for each track, varies from 29 to 123 ft. The tubes themselves are 11 ft. 8 ins. in diameter on tangents, and 12 ft. 6 ins. on curves. At the stations the tunnels are increased to about 21 ft. in diameter and at various stations connections are made with other underground railways.

The road is so arranged that the approach to each station is up hill, thus aiding the brakes, and down hill as the train departs, thus assisting the motors

### High Altitude.

The new mountain railway from Brienz to the summit of the Brienzer-Rothhorn, which is now open to tourists, is not only the highest in Europe, but the highest in the world. The Swiss *Verkers Zeitung* gives the following table of comparative elevation above the sea level of the principal mountain railways: Brienzer-Rothhorn, 2,252 metres; Central Pacific, 2,160; Pilatus Railway, 2,070; Rigi Railway, 1,750; Monte Generoso, 1,639; Murren Railway, 1,611; Brenner Railway, 1,367; Canadian Pacific, 1,312; Arlberg, 1,310; Vesuvius, 1,185; St. Gothard Railway, 1,155; Brunig, 1,064; Einsiedeln, 894; Jura Simplon (at Tavannes), 761. All these are above 2,000 feet above the sea.

The International Railway Master Steam Boiler Makers' Association and the Master Steam Boiler Makers' Association will meet in joint convention at Cleveland, Ohio, next May to organize one large and grand body of foreman boilermakers. This sort of concentration is a move in the right direction.

# Of Personal Interest

Mr. W. H. Willis has been appointed signal engineer of the Erie Railroad, vice Mr. C. H. Morrison, resigned.

Mr. W. B. Ryan has been elected vice-president of the Tehuantepec National, with headquarters at Rincon Antonio, Mex.

Mr. H. Putnam has been appointed assistant purchasing agent of the Mexican Central, with headquarters at Mexico City, Mex.

Mr. C. F. Gregory has been appointed master mechanic of the Boyne City, Gaylord & Alpena, with headquarters at Boyne, Mich.

Mr. Charles Kreider has been appointed general boiler inspector of the Philadelphia & Reading, with headquarters at Reading, Pa.

Mr. M. J. Gorman has been appointed traveling fireman of the Lake Superior division of the Canadian Pacific, with headquarters at Schreiber, Ont.

Mr. J. M. Fulton has been appointed master mechanic of the Chihuahua division of the Mexican Central, with headquarters at Chihuahua, Mex.

Mr. F. E. Conners has been appointed assistant general purchasing agent of the Atchison, Topeka & Santa Fe, with headquarters at Chicago, Ill.

Mr. C. Gifford has been appointed master mechanic of the Louisville & Nashville, with headquarters at Mobile, Ala., succeeding Mr. H. M. Minto.

Mr. George Burnham, Jr., recently resigned from the firm of Burnham, Williams & Co., owners of the Baldwin Locomotive Works at Philadelphia.

Mr. R. H. Rutherford has been appointed master mechanic of the Torreon division of the Mexican Central, with headquarters at Torreon, Mex.

Mr. A. Marchessault has been appointed traveling fireman of the Eastern division of the Canadian Pacific, with headquarters at Montreal, Can.

Mr. E. A. Freeman has been appointed locomotive foreman of the Canadian Pacific, with headquarters at Cartier, Ont., vice Mr. A. J. Holtby, transferred.

Mr. P. W. Conley has been appointed superintendent of terminals of the St. Louis & San Francisco, at St. Louis, Mo., vice Mr. B. W. Moore, resigned.

Mr. W. P. Dawson has been appointed acting general foreman of the locomotive and car departments of the Chicago, Burlington & Quincy, at Edgemont, South Dakota.

The headquarters of Mr. W. H. Stillwell, general manager of the Argentine Central, has been removed from Silver Plume, Col., to Denver, Col. He will be found in Room 314, Colorado Building.

Mr. James McCrea was recently elected president of the Pennsylvania Railroad, succeeding the late A. J. Cassatt. Mr. McCrea is still in the prime of life, and all his railroad service has been on the Pennsylvania system. He has been more closely identified with Lines West, but nevertheless he has spent considerable time in the East, and is therefore familiar with the details of both great divisions of this road. He begins his work with a full knowledge of Mr. Cassatt's plans and policy for the future. Mr. McCrea's first work was in the engineering department. He started, like the late president, as a rodman, and was employed on the Connellsville & Southern Pennsylvania. Three years later he became assistant engineer



JAMES McCREA.

on the construction of the Bennett's branch extension of the Allegheny Valley. In 1871 he was appointed principal assistant engineer in the construction department of the Pennsylvania Railroad, and in 1874 was made assistant engineer of maintenance of way of the Philadelphia division. The next upward step was in the following year, when he was appointed superintendent of the middle division, and from 1878 to 1882 he was superintendent of the New York division; after this went West as manager of the Chicago, St. Louis & Pittsburgh, which is now a part of the Pittsburgh, Cincinnati, Chicago & St. Louis. In 1885 he became general manager of the Pennsylvania Lines west of Pittsburgh, and two years later was also elected fourth vice-president. He was elected second vice-president in 1890, and in 1891, first vice-president. Mr. McCrea has been a director of the Pennsylvania Railroad and president of the Cincinnati & Musk-

ingum Valley, the Vandalia, the Grand Rapids & Indiana, and the Cleveland, Akron & Columbus, and the first act of the board of the Pennsylvania Railroad this year was to elect Mr. McCrea to the highest position in their gift.

Mr. A. H. Gairns has been appointed master mechanic of the first division on the Denver & Rio Grande, with headquarters at Burnham shops, Denver, Col.

Mr. D. D. Briggs has been appointed master mechanic of the Louisville & Nashville, with headquarters at Montgomery, Ala., succeeding Mr. C. Gifford.

Mr. P. A. Buck has been appointed superintendent of the Illinois division of the Missouri Pacific, with office at Chester, Ill., vice Mr. B. G. Fallis, resigned.

Mr. A. J. Holtby, heretofore locomotive foreman of the Canadian Pacific at Cartier, Ont., has been transferred to Ottawa, Ont., vice Mr. T. Hudson, resigned.

Mr. Herbert Riddle has been appointed roundhouse foreman of the Denver & Rio Grande, with headquarters at Salida, Col., vice Mr. W. C. Chambers, resigned.

Mr. H. G. Clark has been appointed superintendent of the Eastern Division of the Missouri Pacific Railway, with office at Sedalia, Mo., vice Mr. W. J. McKee, promoted.

Mr. J. Cannon has been appointed superintendent of the Missouri Division of the Missouri Pacific Railway, with office at De Sota, Mo., vice Mr. J. W. Daniels, transferred.

Mr. Walter Schroder, formerly an engineer on the Montana division of the Great Northern, has been appointed traveling engineer on the same division of this road.

Mr. D. E. Brown has been appointed general superintendent of the Canadian Pacific Railway Company's trans-Pacific steamship service, with office at Vancouver, B. C.

Mr. Thomas Murray has been appointed road foreman of engines of the Aurora division of the Chicago, Burlington & Quincy, with headquarters at Aurora, Ill.

Mr. J. Wilson, heretofore shop foreman of the Canadian Pacific Railway at Brandon, Man., has been appointed locomotive foreman at the same station, vice Mr. R. Pyne, promoted.

Mr. F. H. Greene, heretofore purchasing agent of the Lake Shore & Michigan Southern, has been appointed purchasing agent of all the New York Cen-

tral lines, with headquarters at New York.

Mr. L. G. Cannon has been appointed vice-president and general manager of the Nevada Northern, with headquarters at New York, vice Mr. M. L. Requa, resigned.

Mr. William McMasters has been appointed assistant purchasing agent of the Chicago, Indiana & Southern and the Indiana Harbor, with headquarters at Chicago, Ill.

The title of Mr. Henry Bartlett, superintendent of motive power of the Boston & Maine, has been changed to that of general superintendent, mechanical department.

Mr. J. W. Daniels has been appointed superintendent of the White River Division of the Missouri Pacific Railway, with office at Aurora, Mo., vice Mr. H. G. Clark, transferred.

Mr. J. E. Snedeker has been appointed superintendent of the Southern Kansas Division of the Missouri Pacific Railway, with office at Coffeyville, Kas., vice Mr. J. Cannon, transferred.

Mr. J. E. Cameron, formerly master mechanic of the Atlanta, Birmingham & Atlantic, has been appointed superintendent of that road, with headquarters at Fitzgerald, Ga.

Mr. Percy R. Todd, who recently resigned as first vice-president of the New York, New Haven & Hartford, has been elected vice-president of the Bangor & Aroostook.

Mr. J. T. Carroll has been appointed assistant superintendent of shops of the Lake Shore & Michigan Southern, with headquarters at Collinwood, O., vice Mr. R. D. Fildes, resigned.

Mr. James McDonough has been appointed general foreman of the El Paso & Southwestern, with headquarters at Carrizozo, N. M., vice Mr. H. S. Brickley, assigned to other duties.

Mr. R. F. Jaynes, heretofore general shop foreman of the Lehigh & Hudson, has been appointed to the new office of master mechanic of that road, with headquarters at Warwick, N. Y.

Mr. Amenzo M. Carroll has been appointed assistant master mechanic of the Mohawk division of the New York Central & Hudson River, with headquarters at West Albany, N. Y.

Mr. C. H. Wiggin, assistant superintendent of motive power of the Boston & Maine, will have charge of the company's motive power, with the title, superintendent of motive power.

Mr. H. W. Jacobs, engineer of shop methods and tools of the Atchison, Topeka & Santa Fe, has been promoted to the position of assistant superintendent of motive power of that road.

Mr. George Moll, heretofore road foreman of engines of the Philadelphia & Reading at Philadelphia, Pa., has been appointed master mechanic of the

Reading and Harrisburg divisions of the same road.

Mr. W. L. Richards, formerly chief clerk to the general agent of the Chicago, Milwaukee & St. Paul at Kansas City, Mo., has been appointed superintendent of terminals at that point.

Mr. O. A. Fisher, master mechanic of the Atchison, Topeka & Santa Fe at Chanute, Kan., has been transferred to La Junta, Col., in a similar capacity, succeeding Mr. R. Smith, resigned.

Mr. C. H. Morrison, formerly signal engineer of the Erie Railroad, has been appointed signal engineer of the New York, New Haven & Hartford, with headquarters at New Haven, Conn.

Mr. A. B. Ramsdell has been appointed trainmaster of the West Iowa division of the Chicago, Rock Island & Pacific, with headquarters at Des Moines, Ia., vice Mr. F. M. Patt, transferred.

Mr. Thomas J. Tonge has been appointed superintendent of motive power and rolling stock, bridges, building and water service of the Santa Fe Central, with headquarters at Estancia, N. M.

Mr. E. O. Shively, formerly assistant division master mechanic of the Wabash at Decatur, Ill., has been appointed general foreman of locomotives of the same road, and the former position has been abolished.

Mr. C. W. Seddon, superintendent of shops of the Great Northern at Superior, Wis., has been appointed superintendent of motive power of the Duluth, Missabe & Northern, with office at Proctor, Minn.

The Nathan Manufacturing Company, of New York, take great pleasure in announcing that Mr. Chas. R. Kearns after an enforced absence of six years, due to illness, has again resumed his duties with the company.

Mr. Albert McCready has been appointed road foreman of engines of the first and second districts of the Albuquerque division of the Atchison, Topeka & Santa Fe, Coast Lines, vice Mr. James Englehart, resigned.

Mr. Harvey Rhoads has been appointed general foreman of the Youngtown shops at Louisville, Ky., on the St. Louis-Louisville lines of the Southern Railway, with jurisdiction over the Louisville division and its branches.

Mr. John McGie, master mechanic of the Chicago, Rock Island & Pacific at Shawnee, Okla., has been appointed master mechanic of the Arkansas and Louisiana divisions of the same road, with headquarters at Little Rock, Ark.

Mr. Walter McMullan, formerly roundhouse foreman at Grand Rapids, Mich., on the Grand Rapids & Indiana Railway, has been transferred to the position of assistant machine shop foreman at the same place on the same road.

Mr. C. C. F. Bent, heretofore general

superintendent of the Baltimore & Ohio, has been appointed general manager of the Baltimore & Ohio Southwestern, with headquarters at Cincinnati, O., vice Mr. W. H. Greene, resigned.

Mr. W. E. Kirkwood has been promoted from road foreman of engines of the third division of the Seaboard Air Line, to assistant trainmaster, with headquarters at Abbeville. He will also perform the duties of road foreman of engines.

Mr. E. T. James, who recently resigned as shop superintendent of the Lehigh Valley, has been appointed master mechanic of the New York, New Haven & Hartford, with office at New Haven, Conn., vice Mr. S. R. Richards, promoted.

Mr. A. R. Manderson has been appointed master mechanic of the Portland & Rumford Falls Railway and the Rumford Falls & Rangely Lakes Railroad, with office at Rumford Falls, succeeding Mr. M. R. Davis, assigned to other duties.

Mr. W. J. Haynen has been appointed superintendent of shops of the Père Marquette, with headquarters at Grand Rapids, Mich., vice Mr. M. C. Gregory, resigned. Mr. Haynen was formerly master mechanic of the Detroit, Toledo & Ironton.

Mr. W. H. Wright, heretofore district superintendent of the Atlantic Coast Line, has been appointed superintendent of the Savannah division of the Central of Georgia, with headquarters at Savannah, Ga., vice Mr. J. C. O'Dell, resigned.

Mr. J. W. Robins, division superintendent of the Gulf, Colorado & Santa Fe at Cleburne, Tex., has been appointed vice-president and superintendent of the Chicago, Rock Island & Gulf, with headquarters at Fort Worth, Tex., vice Mr. S. B. Hovey, resigned.

Mr. George A. Post, Jr., M. E., Cornell, '05, has resigned his position as a sales engineer with the Westinghouse Machine Company and accepted service as engineer representative with the Standard Coupler Company, of 160 Broadway, New York City.

Mr. D. E. Cain, who recently resigned as general manager of the Southwestern district of the Chicago, Rock Island & Pacific, has been appointed assistant to vice-president Schlacks, of the Denver & Rio Grande, in charge of operation, with headquarters at Denver, Col.

Mr. Arthur Tomalin, formerly news editor of the Newark *Evening News*, has been appointed general advertising manager of the Central Railroad of New Jersey and editor of its monthly magazine, *The Suburbanite*, with office at 143 Liberty street, New York.

Mr. F. E. McCormack, chief trainmaster of the Rome, Watertown & Og-



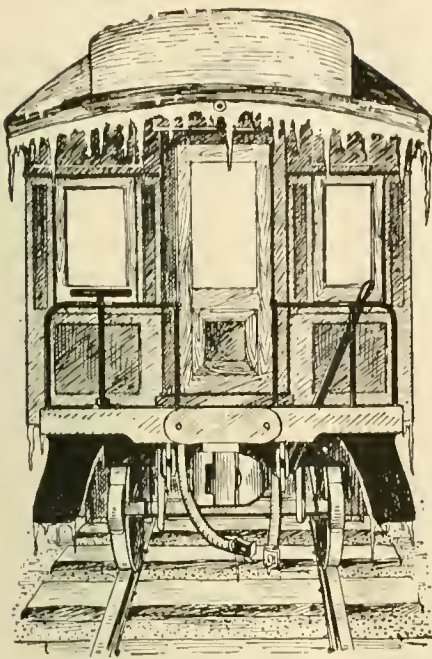

## The Cold Test

With the bleak, cold weather comes more or less imperfect action of the air brakes, and worry and trouble for the engineer as a result. If nothing is done to relieve this condition, you will be bothered all winter, and consequences may be serious.

When the air brake system is lubricated with Dixon's Graphite Air Brake and Triple Valve Grease the brakes respond sensitively to all reductions of pressure. Even in the coldest winter weather this grease will not stiffen and result in emergency action of the brakes when service application is wanted.

Get "proof" sample No. 69-I and make some trial tests on your engineer's valve and angle cocks.

---

**JOSEPH DIXON  
CRUCIBLE CO.  
Jersey City, N. J.**

densburg division of the New York Central & Hudson River, has been appointed to the new position of assistant superintendent of the above named division, with headquarters at Watertown, N. Y.

Mr. Geo. W. Wildin, until recently mechanical superintendent of the Erie Railroad, has been appointed assistant superintendent of motive power on the Lehigh Valley Railroad. This is a new position which has just been created. Mr. Wildin's headquarters are at South Bethlehem, Pa.

Mr. J. W. Marden, heretofore assistant master car builder of the Boston & Maine, has been promoted to be master car builder of that road, with headquarters at Boston, Mass., vice Mr. John T. Chamberlain, resigned.

Mr. C. M. Taylor, who recently resigned as mechanical superintendent of the Western Grand division of the Atchison, Topeka & Santa Fe, has been appointed master mechanic of the Panhandle division of the Rock Island, with headquarters at Shawnee, Okla., vice Mr. John McGie, transferred.

The Kobbe Co., publishers of "Compressed Air," announce the removal of their offices from 90-92 West Broadway to 108 Fulton street, New York. The increasing use of compressed air, and the fact that quarters had to be found for the new men being added to their staff, necessitated the removal to more commodious offices.

Mr. F. P. Roesch, master mechanic on the Southern Railway at Birmingham, Ala., has been transferred to Spencer, N. C., in the same capacity on the same road. This is considered in the light of a promotion and Mr. Roesch has our hearty congratulations. He is an old friend and a valued contributor to RAILWAY AND LOCOMOTIVE ENGINEERING.

Mr. J. A. MacNeill has been appointed chief inspector of the Union Pacific, with headquarters at Omaha, Neb., vice Mr. F. Jerdone, Jr., resigned. He has charge of the inspection of passenger and freight cars and locomotives and all materials entering into their construction. Mr. MacNeill was formerly in the inspection department of the Atchison, Topeka & Santa Fe.

Mr. Thos. B. Purves, Jr., has been appointed superintendent of motive power and car department of the Denver & Rio Grande, with headquarters at Denver, Col., vice Mr. J. R. Groves, resigned. Mr. Purvis has been connected with the motive power department of the Boston & Albany for a number of years. His many friends wish him every success in his new position in the West.

Mr. J. W. Duntley, president of the Chicago Pneumatic Tool Company, recently sailed for Europe for the pur-

pose of closing up several important contracts for pneumatic tools and appliances. Several exhaustive tests were conducted during the year 1906 by large foreign institutions, with the result that the business has reached a point where they are ready to close, thus necessitating Mr. Duntley's trip for the purpose of finally negotiating contracts.

Mr. J. P. O'Doherty, formerly chief clerk to the superintendent of motive power of the Canada Atlantic and later to the master mechanic of the Grand Trunk Railroad at Ottawa, Canada, has been appointed general agent of the Richelieu & Ontario Navigation Company in charge of stores, mechanical accounts, etc., at Sorel, Quebec. On leaving the service of the Grand Trunk, his fellow employes presented him with a gold watch and chain in token of their good will and esteem. We wish Mr. O'Doherty every success in his new field of labor.

Mr. Norman Wight, a locomotive engineer on the Canadian Pacific, was recently presented by the Royal Canadian Humane Association, with the honorary parchment of the association, for life saving. When near St. Jerome, Quebec, in charge of the engine of train No. 48, he saw a child on the track ahead. The little girl was apparently bewildered and was in imminent danger of being run over. Wight at once applied the brake in the emergency, but finding that the train could not be stopped before reaching the little girl, he climbed down on to the pilot of the engine and picked her up. The train ran about two car lengths after passing the place where the child had been standing. The parchment has been presented to him in recognition of this act of bravery.

Col. John T. Dickenson, who for the past several years has been connected with the Consolidated Railway Electric Lighting and Equipment Company, has tendered his resignation and accepted the position of vice-president of the Bliss Electric Car Lighting Company of Milwaukee. Col. Dickenson's headquarters will be in New York at the new offices of the Bliss Electric Car Lighting Co., in the Night & Day Bank Building, Fifth avenue and Forty-fourth street, opposite Sherry's and Delmonico's. The Chicago offices of the Bliss Electric Car Lighting Company will be in the Monadnock Building, and Mr. W. M. Lalor, who was formerly also with the Consolidated Railway Electric Lighting and Equipment Company, will be in charge of the Chicago office as assistant general sales manager. The extensive additions to the large plant of the Bliss Electric Car Lighting Company in Milwaukee have been completed.

Mr. Howard M. Post has recently accepted the position of advertising manager with the Quincy, Manchester, Sargent Company, manufacturers of railroad appliances, who have offices in Chicago and New York with factories at Chicago Heights, Ill., Milwaukee, Wis., and Plainfield, N. J., this company being the successor to the Railway Appliances Company, The Q. & C. Company and the Pedrick and Ayer Company. They are also the sole agents for the Milwaukee Elastic Nut and Bolt Company. Mr. Post originally fitted himself for a telephone engineer and held a position as telephone switchboard installer with the Western Electric Company of Chicago for three years. Later he accepted a position as telephone engineer with the Kellogg Switchboard and Supply Company of Chicago. His complete knowledge of the telephone business later led the Kellogg Company to offer him the advertising managership, which he accepted and handled very successfully for a number of years. During the time he occupied the position of advertising manager with the Kellogg Company, Mr. Post turned out a large amount of fine catalogue work. He is thoroughly conversant with all branches of the advertising business and his experience and push should make him a valuable acquisition to the Quincy, Manchester, Sargent Company.

Railroad companies have perhaps never paid so much attention to the safeguarding of their tracks as they are doing at the present time. A very important contract for the installation of automatic block signal has been placed by the Boston & Maine Railroad with the Union Switch & Signal Company, of Swissvale, Pa. This contract calls for all the material necessary to cover the equipment of the automatic block signal system over at least one thousand miles of track. The work involves an expenditure of several hundred thousand dollars and is one of the largest single contracts for automatic block signalling that has ever been placed by any company.

An amusing story of a caddie is told in Golf Illustrated. It refers to a caddie in St. Andrews who was mainly not noted for his habits of sobriety. He turned up one day to carry his employer's clubs in rather a muddled state. The employer took him to task, and tried to get at him by pointing out the example he was setting to his son. The caddie could easily refute this argument: "I do think of him," he said; "I have done him a great deal of good. I have been an awful warning to him. He is teetotal, which he would never have been but for me."

### Fighting Tooth and Nail for the Road.

One constantly hears of dogs being used for various services by mankind, and the work of the battery mule and the commissariat camel and the elephant in the British army in India is well known, but one does not often hear of gentle puss being pressed into service, but here she is, working or rather fighting tooth and nail for the railway. Perhaps the oddest railway force in the world is a cat-corps at a station on the London & North-Western, where many thousands of sacks are constantly lying. The cats are fed daily with milk only, and an appropriation is made for their support because otherwise the busier the cats became and the more rats they bagged the less there would be for them to live on. The rats are thus kept from destroying the sacks, and a number of women are employed to mend the holes which are made in the sacks by the rats which the cats of the company do not catch. The cats attend to their work very well considering everything and are not often sacked by the company for failure as ratters. Continuance in service is considered evidence of satisfaction and raises of pay are not usually considered.

### Injectors and Other Appliances.

A good catalogue is more than simply a list of articles or manufactured commodities; that is in a modern acceptance of the idea as exemplified by the supply houses which look after the railroad trade, and probably as fine an example as one usually sees of this is to be found in what must be called the catalogue of the Nathan Manufacturing Company, of 92-94 Liberty street, New York. This concern has just recently got out their railway edition and it is a good example of the printer's and engraver's art. This company, it will be remembered, makes injectors, injector attachments, lubricators, oilers, and engine and boiler fittings. The catalogue is standard size, that is, it is the same size as RAILWAY AND LOCOMOTIVE ENGINEERING. The various appliances, such as the Monitor injector, is not only shown in excellent half tones with external parts lettered for reference, but there are illustrated in full page good clear line cuts with parts numbered for reference and for ordering. Directions for the application of the injector are given, and also directions for starting it, the pipe capacities required for the various sizes and other information and data.

One of the features of this catalogue is three inset sheets of large size, bound with the rest and folded between the pages. These insets are outline drawings of engines, or charts showing the position of the injectors, checks,

# GOLD Car Heating and Lighting Co.

Manufacturers of

ELECTRIC,  
STEAM AND  
HOT WATER  
APPARATUS  
FOR RAILWAY CARS

EDISON  
STORAGE  
BATTERY  
FOR RAILWAY CAR  
LIGHTING

Largest Manufacturers in the World  
of Car Heating Apparatus

Catalogues and Circulars  
cheerfully furnished

Main Office, Whitehall Building  
17 BATTERY PLACE  
NEW YORK

# Ball's Official R.R. Standard Watches

16 AND 18 SIZE

17 and 21 Ruby Jewels, Sapphire Pallets

Ball's Improved Safety Double Roller



Are without question the finest watches that American talent and skilled labor can produce, and they are giving such universal satisfaction that we have no hesitancy in claiming that they are the best and safest railroad watch on the market.

Tests severe and numerous have proven this fact to the most critical

users in all sections of the country, to which thousands of good Railroad and Brotherhood men are ready to certify.

We have an authorized agent in nearly every railroad center. Call on him for information and facts. Write us for descriptive matter.

**The Webb C. Ball Watch Co.**

Watch Manufacturers

Ball Building, Cleveland, Ohio, U.S.A.

## METAL PRESERVATIVE PAINTS AND PRIMER

for locomotives, boilers, stacks, front-ends, gearing, framework, metal roofs, etc.

Tell us your needs.

Metal preservative paints have been our specialty for 22 years.

Paints for all conditions.

THE

**STANDARD PAINT CO.**

Sole Manufacturers

100 William St., New York

CHICAGO

ST. LOUIS

### WANTED

Detail Mechanical Draughtsmen, men familiar with locomotive and car construction preferred. Apply, giving references, experience and salary expected, to Box No. 40, care Railway and Locomotive Engineering.

and Cheney. This is a book that no person engaged in mechanical occupations can afford to do without. Enables any workman to figure out all the shop and machine problems which are so puzzling for want of a little knowledge. We sell it for 50 cents.

"Firing Locomotives," Sinclair. Treats in an easy way the principles of combustion. While treating on the chemistry of heat and combustion, it is easily understood by every intelligent fireman. The price is 50 cents.

"Skeevers' Object Lessons," Hill. A collection of the famous object lesson stories which appeared in this paper several years ago. They are interesting, laughable, and, best of all, they are of practical value to-day. \$1.

"Standard Train Rules." This is the code of train rules prepared by the American Railway Association for the operating of all trains on single or double track. Used by nearly all railroads. Study of this book would prevent many collisions. Price, 50 cents.

"Mechanical Engineers' Pocketbook," Kent. This book contains 1,100 pages,

and Cheney. This is a book that no person engaged in mechanical occupations can afford to do without. Enables any workman to figure out all the shop and machine problems which are so puzzling for want of a little knowledge. We sell it for 50 cents.

"Firing Locomotives," Sinclair. Treats in an easy way the principles of combustion. While treating on the chemistry of heat and combustion, it is easily understood by every intelligent fireman. The price is 50 cents.

"Skeevers' Object Lessons," Hill. A collection of the famous object lesson stories which appeared in this paper several years ago. They are interesting, laughable, and, best of all, they are of practical value to-day. \$1.

"Standard Train Rules." This is the code of train rules prepared by the American Railway Association for the operating of all trains on single or double track. Used by nearly all railroads. Study of this book would prevent many collisions. Price, 50 cents.

"Mechanical Engineers' Pocketbook," Kent. This book contains 1,100 pages,

### A Great Truth.

Thomas Carlyle spoke many truths in a telling way. This is one of them: "O thou that pinest in the imprisonment of the Actual, and criest bitterly

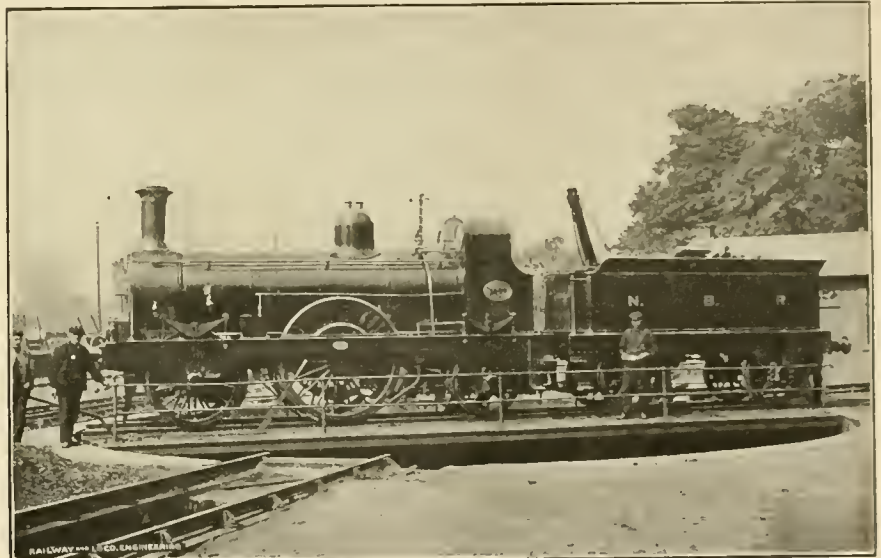

NORTH BRITISH "SINGLE," READY FOR THE ROAD.

to the gods for a kingdom wherein to rule and create, know this of a truth: the thing thou seekest is already with thee, here or nowhere, couldst thou only see." This truth applies to us all, but to none more than railroad men. The complex mechanism of the mechanical appliances used on railways is a mystery and a burden to thousands of honest toilers, and they need help. It is within the reach of the humblest.

RAILWAY AND LOCOMOTIVE ENGINEERING lightens their burdens and clears the mysteries for them. We have books also that thousands of railroad men have been reading and gathering knowledge from. A few of our books are as follows:

"Machine Shop Arithmetic," Colvin

6x3¼ ins., of closely printed minion type, containing mechanical engineering matter. It ought to be in the bookcase of every engineer who takes an interest in engineering questions. We use it constantly as a reference for questions sent to us to be answered. Full of tables and illustrations. Morocco leather, \$5.00.

"Locomotive, Simple, Compound and Electric," Regan. An excellent book for people interested in any kind of locomotive. It will be found particularly useful to men handling or repairing compound locomotives. It is the real locomotive up to date. \$2.50.

"Simple Lessons in Drawing for the Shop," by O. H. Reynolds. This book was prepared for people trying to acquire the art of mechanical drawing

without a teacher. The book takes the place of a teacher, and has helped many young men to move from the shop to the drawing office. 50 cents.

"Locomotive Running Repairs," by L. C. Hitchcock. This book contains directions given to machinists by the foreman of a railroad repair shop. It

#### Ideal Track.

What an ideal roadbed is supposed to be, both for wearing qualities and appearance, is represented in four stretches of the main line on the Pennsylvania Railroad between Philadelphia and Pittsburgh. For example, grassy banks sloping smoothly down, when the tracks are

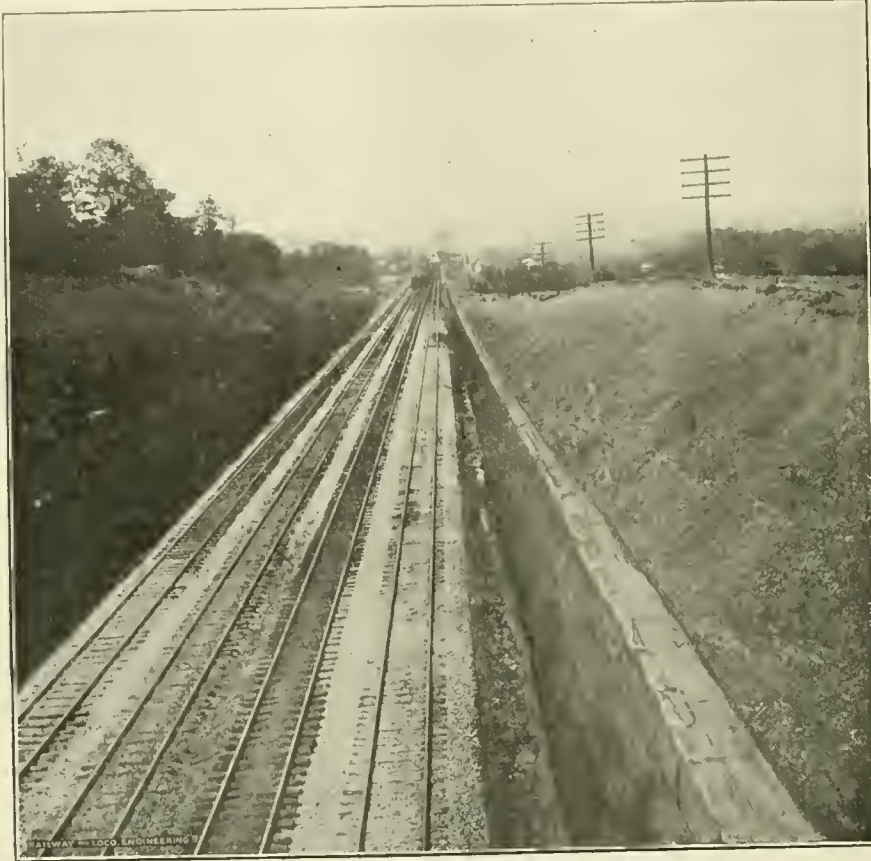

FOUR-TRACK ROADBED WITH GOOD SIDE DITCH.

tells how to set valves, set up shoes and wedges, fit guides, care for piston packing, and, in fact, perform all kinds of work that need a thoughtful head and skilful hands. 50 cents.

"Care and Management of Locomotive Boilers," Raps. This is a book that ought to be in the hands of every person who is in any way interested in keeping boilers in safe working order. Written by a foreman boilermaker. Also contains several chapters on oil burning locomotives. Price, 50 cents.

"Locomotive Link Motion," Halsey. Any person who gives a little study to this book ceases to find link motion a puzzle. Explains about valves and valve motion in plain language. Price, \$1.00.

RAILWAY AND LOCOMOTIVE ENGINEERING is a practical journal of railway motive power and rolling stock, and it is so not only in name but in reality. By reading it you get a knowledge of what others think and do. \$2.00 per year; bound volumes, \$3.00. It is advisable to send in orders for these bound volumes at an early date as only a limited number will be issued.

in a cut, are the features that strike the passenger's eye. Nine people out of ten think these sodded slopes are put there to please the eye. The grass, however, is more useful than ornamental, because water flowing down unsodded slopes washes dirt and stones into the ditch beside the track and so chokes drainage.

In the summer of 1905 the late A. J. Cassatt suggested the improvement in order to reduce the cost of maintenance. He appointed a committee of engineers of the company to prepare plans for a bed with draining facilities as nearly perfect as possible, and the fifteen miles of new roadbed is the result of the committee's report. One of the two five-mile stretches of standard roadbed is near Lancaster, on the Philadelphia Division, and the other near New Port, on the Middle Division. The two shorter stretches, two and a half miles each, are on the Pittsburgh Division, one near Cresson, on the western slope of the mountain, and the other about fifty miles east of Pittsburgh at Hillside.

There is a ditch 10½ ft. wide on each side of a four-track road, and the bottom of the ditch is 3½ ft. below the level of

## JUST PUBLISHED The Walschaert Locomotive Valve Gear

By W. W. WOOD.

Nearly 200 pages.

Fully Illustrated.

PRICE \$1.50



The only book issued that is devoted exclusively to the Walschaert Valve Gear, and it fills a demand which, during the last few months, has become very important. If you would thoroughly understand the Walschaert Valve Gear you should possess a copy of this book, as the author takes the plainest form of a steam engine—a stationary engine—in the rough, that will only turn its crank in one direction—and from it builds up—with the reader's help—a modern locomotive equipped with the Walschaert Valve Gear, complete. The points discussed are clearly illustrated; two large folding plates that show the position of the valves of both inside or outside admission type, as well as the links and other parts of the gear when the crank is at nine different points in its revolution, are especially valuable in making the movement clear. These employ sliding cardboard models which are contained in a pocket in the cover.

The book is divided into four general divisions, as follows: I. Analysis of the gear. II. Designing and erecting the gear. III. Advantages of this gear. IV. Questions and answers relating to the Walschaert Valve Gear, which will be especially valuable to firemen and engineers preparing for an examination for promotion.

Just Issued—1907 Revised and Enlarged Edition.

## UP-TO-DATE AIR BRAKE CATECHISM

By ROBERT H. BLACKALL.

PRICE \$2.00

The Standard Book on the Air Brake. Contains over 2,000 Questions and Answers giving a detailed description of all the Old Standard and Improved Equipment.

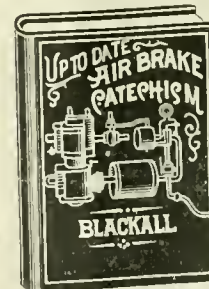

Owing to the many changes and improvements made in the Westinghouse Air Brake it has been found necessary to issue the new, revised 1907 edition of the Air Brake Catechism, which contains all the latest information necessary for a railroad man to pass his examination on the new as well as the older style of brake.

The new revised 1907 edition is right up to date and covers fully and in detail the Schedule E. T. Locomotive Brake Equipment, H-5 Brake Valve, SF Brake Valve (Independent), SF Governor Distributing Valve, B-4 Feed Valve, B-3 Reducing Valve, Safety Valve, K Triple Valve (Quick-Service) Compound Pump.

Send for a special circular of these books as well as our Other Railroad Books. Copies of these books sent prepaid on receipt of price.

Agents Wanted Write for our special terms. You can make equal to a month's pay selling our books on the side.

The Norman W. Henley Publishing Co.  
132 Nassau St., New York, U. S. A.

# How Ambitious Railroaders Advance



There are hundreds of railroad employes drudging along today in poorly paid positions who could better themselves by the mere stroke of a pencil if they would but muster up enough determination. An institution that has enabled thou-

sands of men to secure promotion stands ready to qualify any ambitious railroader for a better position and better earnings, in his spare time and at his own home. The following story shows the results we accomplish:

J. A. Anders of Oelwein, Ia., was working as a locomotive fireman on one of the Western railroads and was earning about \$60 per month. Being dissatisfied with his position and earnings he took advantage of the I. C. S. opportunity to better himself. As a result he is today a locomotive engineer and is earning \$95 a month more than when he enrolled.

Would YOU accept a better position and increased earnings if they were offered you? Are you willing to investigate the surest and easiest way on earth to secure them?

Then get out your pencil and knife and cut out, mark, and mail the coupon below. It costs you nothing to do this. Don't put it off until tomorrow. Do it now.

- |                          |                    |
|--------------------------|--------------------|
| 75 Gen'l Foreman R. R.   | 25 Mining Engineer |
| 76 R. R. Shop Foreman    | 22 Architect       |
| 77 R. R. Trav. Engineer  | 1 Bookkeeper       |
| 78 R. R. Trav. Fireman   | 2 Stenographer     |
| 79 Locomotive Engineer   | 3 Ad Writer        |
| 80 Air-Brake Instructor  |                    |
| 81 Air-Brake Inspector   |                    |
| 82 Air-Brake Repairman   |                    |
| 16 Mechanical Engineer   |                    |
| 13 Mechanical Drafts.    |                    |
| 12 Electrical Engineer   |                    |
| 83 R. R. Construct. Eng. |                    |
| 19 Civil Engineer        |                    |
| 24 Bridge Eng.           |                    |
| 9 Chemist                |                    |

**INTERNATIONAL  
CORRESPONDENCE SCHOOLS**

Box 505, Scranton, Pa.

Please explain, without further obligation on my part, how I can qualify for a larger salary and advancement to the position numbered \_\_\_\_\_

Name \_\_\_\_\_

St. and No. \_\_\_\_\_

City \_\_\_\_\_ State \_\_\_\_\_

the top of the tie. That means that there must be a decided slope from the lowest part of the roadbed to the ditch, so that water trickling through the ballast will be able to flow off.

The cost of the improvement of even the fifteen miles has been large. Seventy-three thousand cubic yards of new ballast were used in that distance. This ballast was not to make the track more steady, but to make the drainage perfect. The cost of sodding with blue grass was very great. It was estimated that 60 per cent. of the entire cost was for cutting down and sodding the slopes. The railroad, however, receives a substantial return for the outlay in securing a most satisfactory drainage system and a roadbed of greatly improved appearance.

### Reliable Steel.

Thomas Prosser & Son, Gold street, New York, had an exhibit at the show of the Automobile Association of America which attracted much attention owing to the fact that it gave ocular demonstration of the hard usage to which first-class

a less reliable material is dangerous.

The indications now are that Thomas Prosser & Son will soon be as successful with material needed in the construction of automobiles as they have been for that used in railway machinery. They are handling Krupp's Special Chrome Steel, which can be used unhardened, having a minimum elastic limit of 95,000 pounds and other properties equally high. If an intended purchaser finds that a maker is using Krupp steel for the principal parts of an automobile he may safely place his order.

### Gift to Purdue.

The Carnegie Institution of Washington, D. C., has made a grant of \$3,000 a year for a period of four years to Prof. W. F. M. Goss, of Purdue University, Lafayette, Ind., for the purpose of determining the value of superheated steam in locomotive service; first, in connection with single expansion engines, and second, in connection with compound engines. This is the second grant which the institution has made to



WELL KEPT AND CLEAN SIDE DITCH.

steel can be subjected without breakage.

Thomas Prosser & Son are the American agents for the famous Krupp steel, which has long been recognized as the best for purposes involving great stresses and sudden destruction shocks. It has paid railroad companies to pay the high duty on Krupp steel that they could use it for tires and for other purposes where

Purdue. While given personally to Dr. Goss, the dean of the faculty, its effect will be to stimulate and to make more effective the work of the Purdue locomotive laboratory. Funds thus received are employed in supplementing the resources of the laboratory in the same manner as the funds derived from all other sources are applied.

**Harnessing Victoria Falls.**

The falls of the Zambesi River, which we described in our last issue, are about to be electrically harnessed in the interests of the development of South Africa. The British South Africa Company have shown to interested stockholders in London a system of models, maps, pictures and diagrams illustrating the manner in which the great forces of the stupendous cataract can be utilized upon a scale that will doubtless have an important effect upon the future destinies of South Africa. In that dark continent, work requiring unskilled labor cannot, generally speaking, be done by white men. It is of great importance to increase the economic opportunities for white skilled labor. That the vicinity of the Victoria Falls will become a great industrial center there can be no doubt. The distribution of power to the Transvaal mines is under immediate contemplation, and what has been done at Niagara Falls will in a few years be far surpassed by the utilization of the stupendous force of the Zambesi Falls. With nearly three times the width of Niagara, and more than twice the height of that great cataract, it does not require any great flight of the imagination to realize that with the modern methods of electric transmission the whole table land of Central Africa will feel the effects of the distribution of this titanic power. New industries will spring up, and it

the heavier designs of this type. The pamphlet illustrates and describes twenty-one different designs of 10-wheel locomotives ranging in weight from 64,000 to 150,000, and adapted to a great variety of road and service conditions. This series now includes pamphlets on the Atlantic, Pacific, Consolidation and 10-wheel types and copies of these may be had upon request to the company at 111 Broadway, New York.

**Spirit of the Times.**

The year has begun under the most favorable auspices, both in the industrial activity of the entire country and in the spirit of kindly consideration manifested by the National and State Legislatures in the proposing of measures looking to the amelioration of the condition of the industrial classes. It would be idle to enumerate the benevolent measures aimed at better housing, shorter hours of labor, education facilities, and the means of safeguarding life insurance and other beneficiary institutions. Suffice it to say that a marked departure is being made from the old political methods, which consisted in promising everything and accomplishing nothing.

We are watching with particular interest the proposed legislation affecting the hours of labor of railway employees and rejoice to see a spirit of compromise and good will between the great



SALOON COACH USED IN INDIA BY KING EDWARD VII. WHEN PRINCE OF WALES. IN 1875.

will be by forces such as these that the march of civilization will be hastened rather than by the conquests of rival powers, whose methods of spoliation and robbery have been a blot in the face of the dark continent.

The fifth of the series of pamphlets which is being issued by the American Locomotive Company has recently been published. This pamphlet is devoted to 10-wheel type of locomotives, weighing less than 150,000 lbs., and will be followed shortly by another presenting

railroad corporations and their employees. In all advances in human progress mutual concessions must be made. Already many of the chief railroads have increased the rate of wages, and everything points to a general betterment of the condition of the industrial classes. No class will appreciate the improvement more fully than railway men whose work is not only arduous but is peculiarly exacting, and consequently wearing, and the promise of a better day seems to be at last crowned with some degree of fulfilment.

# Tate Flexible Staybolt



**Strong**

**Effective**

**Economical**

**Flexibility**

**Durability**

**Simplicity**

Holds firebox sheets securely together, and accommodates itself to the unequal expansion of the plates.

## FLANNERY BOLT COMPANY

**PITTSBURG, PA., U. S. A.**

Suite 308, Frick Bldg.

**B. E. D. STAFFORD, - - General Manager**  
Write us for Reference Book

# Homestead Valves

Straightway, Three-way and Four-way, and

# Homestead Locking Cocks

Are Famous the World Over

They cost more, but are worth very much more than other makes. You try them and see.



Brass, 1 1/2 in.

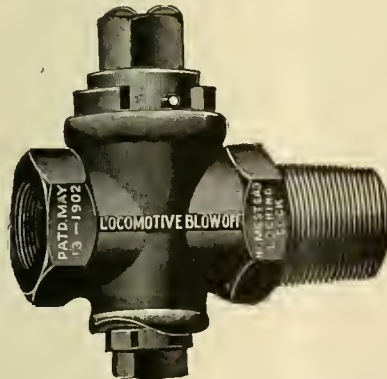

Iron Body, Brass Plug, 1 1/2 in.

**HOMESTEAD VALVE MFG. CO.**

WORKS: **HOMESTEAD, PA.** **PITTSBURG, PA.**

## American Locomotive Sander Company

13th & Willow Sts., Philadelphia, Pa.

Proprietors and Manufacturers

LEACH, SHERRBURNE, DEAN, SANDERS  
HOUSTON, "SHE" and CURTIS

**THE ROBERT W. HUNT & CO.**  
Bureau of Inspection, Tests and Consultation,  
1137 THE ROOKERY, CHICAGO.

66 Broadway, New York.  
Park Building, Pittsburg.  
31 Norfolk House, London, Eng.  
Inspection of Steel Rails, Splice Bars, Railroad Cars, Wheels, Axles, etc. **CHEMICAL LABORATORY**—Analysis of Ores, Iron, Steel, Oils, Water, etc. **PHYSICAL LABORATORY**—Test of Metals, Drop and Pulling Test of Couplers, Draw Bars, etc.  
Efficiency Tests of Boilers, Engines and Locomotives.

The Zephon Chemical Company, of Chicago, inform us that they are satisfied that when their compound has been introduced into a boiler it stays there and acts as a scale remover, or rather that it prevents the formation of scale. The proof of this, which they offer, is that the compound has been used in the boilers of breweries where live steam is used in the direct production of malt, etc. The company claim that there is no foaming where

Jeffa & Jerusalem R. R. Troubles.  
Ben-Ali-Sneezer, late one afternoon,  
Met Sheik Bak-Gammon on old Herib's mount,  
And thus he in the language of the east,  
His multifarious hardships did recount:  
"O Sheik, I bow me in the dust and mourn,  
For lo! whilst browsing on the fertile plain,



DINING CAR USED ON PRINCE OF WALES' TOUR THROUGH INDIA. 1905.

the compound is used and that the prevention of scale, as a necessary consequence, increases the efficiency of the boiler because there is no hard heat-absorbing substance lying on the inside of the sheets and the life of the flues is also considerably lengthened. It is said that the Zephon compound can be dissolved in the mouth without harmful results following. The claim is not made that all waters will be purified with the same grade of this boiler compound. The water used in the locomotives on any division should be analyzed and tested as required. The underlying principle in the Zephon treatment is to introduce into the boiler such chemicals as will form with the encrusting material of the water a soft sludge which will not adhere to sheets or flues but will sink to the bottom and can be readily washed out or blown out when the water is changed, and that the chemical employed is completely used up in the formation of this sludge, in fact that the chemical would rather form sludge than attack the sheets. Samples are sent on request and the Zephon people will send a representative to explain the use of their compound.

A lover of rare old china had a collection that was the envy of her visitors. One day a little girl came with her mother for a call, and being seated in the living room, wonderingly eyed the array of antique dishes. The hostess was much pleased at the child's evident admiration of her treasures, and said: "Well, my dear, what do you think of my china?" The child looked up, and pity was in her eyes as she asked: "Hasn't you dot any pantry?"

Two of my choicest heifers—fair and fat—  
Were caught in limbo and were duly slain  
By that infernal pest of recent birth—  
The half past eight accommodation train!"

Then quoth the Sheik: "One of my whitest lambs,  
Which I did propose soon to drive to town,  
While frisking o'er the distant flowery lea  
Was by that selfsame fatal train run down.  
Now, O Ben-Ali by the prophet's beard,  
What are we ruined shepherd folk to do?  
Suppose we take our troubles into court—  
You swear for me and I will swear for you;  
And so, by mutual oaths, it's possible  
We may most hap'ly pull each other through."

Ben-Ali-Sneezer some months after met  
The Sheik Bak-Gammon, and inclined to sport.  
The two sat down upon a cedar stump  
To talk of their experiences in court.  
Ben Ali quoth: "Them cows was as thin as rails—  
Now that they're gone, it's mighty glad I am!"  
Bak-Gammon said: "Now that the judgment's paid,  
I don't mind telling you that slaughtered lamb,  
So far from being what you swore in court.  
Was, by the great horned spoon,  
not worth a —!"

### Small Hand Drill.

A novel air drill has lately been placed on the market by the Chicago Pneumatic Tool Company. It is called the Chicago Midget, on account of its size, and our illustration shows that one can hold it in the hollow of his hand.

This little drill has a capacity for drilling up to and including 3-16 inch in steel. It weighs 2½ pounds, and the distance from the top of breast plate to the end of spindle is 75⁄8 inches, and from the center of the spindle to the outside of the housing it is 1 inch. The motor speed is 22,000 revolutions per minute,

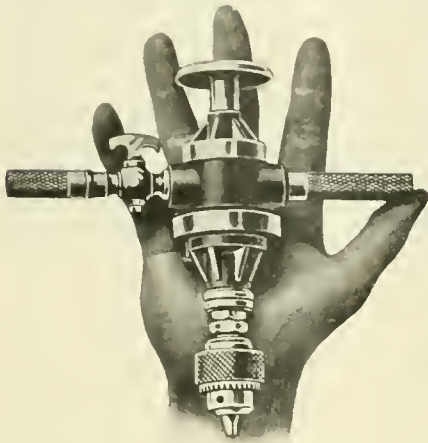

MIDGET DRILL.

and the spindle speed is 2,000 revolutions per minute.

This machine is of the rotary type. It therefore operates at full speed without vibration, and is adapted to drilling tell-tale holes in stay-bolts or for general light work, where accuracy is required.

### Sense and Prejudice of Dogs.

A correspondent writes us giving some personal experience with dogs. He says: My daughter has a little dog which displays mortal antipathy to riding in an automobile. Now, this little cur shows a decided liking for riding in a carriage pulled by horses, but put him on the softest seat of a wind-protected tonneau and off he jumps at the first opportunity, and he stands not upon the order of his going, but springs off when the car is running at its highest speed.

There is no accounting for the taste of dogs in these matters. I once was acquainted with a dog which had a partiality for riding on locomotives, and he rambled at will over all the railways in Great Britain, taking free rides upon the engines. This dog displayed strange likings and antipathies. He never rode farther than over one division on an engine, and when he had settled upon going to some particular point he knew which engine would take him there.

Sometimes he would visit about a sta-

tion or town for a day or two, then he would start upon his travels again. One day he was waiting at Carlisle for a train to come in and he happened to be sitting with his tail across the rail where a passenger train was standing. The train moved on quietly and cut off Jack's tail. He took it as a personal outrage and never was seen in Carlisle afterward.

When Jack made up his mind to take a ride, he generally waited on the platform, near the water column, until an engine came up. Then he would look carefully at the enginemen, and if one was red haired he moved away. He was never known to ride with a red-haired person. He preferred old acquaintances to strangers; but sometimes he showed a disposition to make new acquaintances so long as they were free from lurid hair. Most of the enginemen from Brighton to John O'Groats' knew him, and were ready to share their lunch with Jack.

One day at Rugby Junction Jack had made up his mind to change engines. He had seen an old friend on a locomotive that was starting out, and he attempted the dangerous feat of jumping upon the moving engine. He missed the foot plate and landed under the moving wheels, which ended his career.

Jenkins Prothers, valves and packing, have long been associated together in the public mind, but they are even more closely united in a very comprehensive 1907 catalogue, lately got out by the firm, whose New York address is 71 John street. This catalogue gives views of all kinds of valves, packings, discs, pump valves, etc., and the various sizes are tabulated and the price of each is given. Skeleton drawings fill the last pages of the book, and book it may be called, for it contains 128 pages of the size of railroad club proceedings. These skeleton drawings afford means for giving all the dimensions for a whole series of valves of different sizes, the dimension lines are lettered and a table below interprets the size of each part so that it is in fact an outline working drawing for each. The catalogue is useful for reference, as it covers the whole field occupied by the firm, and it is tastefully and clearly printed. There is an index at the back, classified with appropriate headings for each group of the specialties manufactured by the Jenkins Brothers. Write to the firm in New York or at 31 North Canal street, Chicago, if you would like to have a copy for reference.

### Everything Just Boiling.

A correspondent of the *Northwestern Railroader* advances some odd theories to account for the frequency and severity of storms in modern times. He gives the figures to prove that there are now over

## MASTER CAR BUILDER IS OPEN FOR ENGAGEMENT

Young, Active, used to Big Propositions; Capable of Installing Piece Work; Steel Car Work Handled; Not Afraid of Hard Work.

Further Particulars by Addressing

**J. R. P.**

Care **ANGUS SINCLAIR CO.**  
**136 Liberty Street, New York**

## THE UNION SWITCH & SIGNAL COMPANY

CONSULTING  
AND MANUFACTURING  
SIGNAL ENGINEERS

Automatic Block Signals—Electric  
and Electro-Pneumatic

Interlocking — Electric, Electro-  
Pneumatic and Mechanical

Electric Train Staff Apparatus

General Offices and Works at  
**SWISSVALE, PA.**

### DISTRICT OFFICES:

NEW YORK - - 143 Liberty Street  
CHICAGO - - - Monadnock Block  
ST. LOUIS - - - Frisco Building

## THE TANITE CO. seeks the support of Railroaders because:

The man who uses a TANITE wheel will find it safe. Because pay for a TANITE wheel secures the greatest productive capacity. Because TANITE MILLS EMERY is mined in America and appeals to all who earn wages in America. Because TANITE grinding machines are practical.

THE TANITE CO. sells Emery, Solid Emery Wheels, Buffing Lathes, Guide Bar Grinders, Car Brass Grinders, Bench and Column Grinders, Surfacing Machines, Open Side Emery Planers, Saw Gummers, Automatic Planer Knife Grinders, Diamond Tools, Polishing Paste for Brass and Nickel, Emery Wheel Cutters and Dressers.

The Tanite Co. builds special machines  
for special wants

**THE TANITE CO.**  
**STROUDSBURG, PA**



## Locomotive Blow-Off Plug Valves

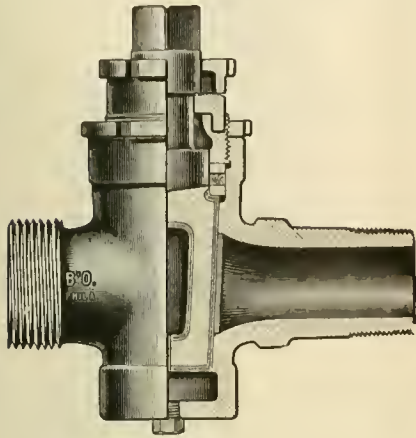

Fig. 9.

All Brass, extra heavy, with Cased Plug. For 250 lbs. pressure. Made with Draining Plug to prevent freezing.

## Locomotive Gauge Cocks

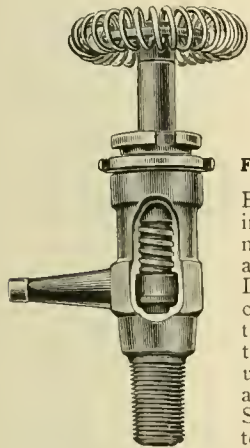

Fig. 23, with Wheel.

For High Pressure

Bordo Self-Grinding Gauge Cocks, made with renewable Hard Bronze Disc. Opened and closed with a quarter turn. Guaranteed Steam tight under the most exacting conditions. Shanks Threaded to specifications for Locomotives.

## Swing-Joints and Pipe Attachment

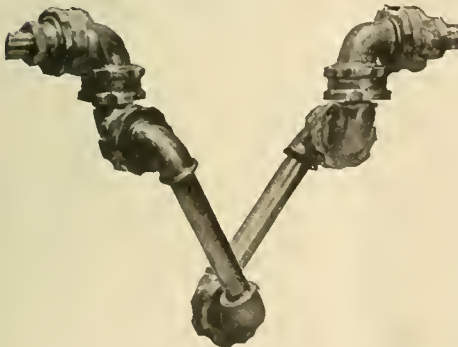

Fig. 33.

May be applied between Locomotive and Tender. These Swing-Joints are suitable for Steam, Gas, Air, Water or Oil.

Complete Booklet on Application  
**L. J. BORDO CO.**  
PHILADELPHIA, PA.

30,000 locomotives in actual use in the United States, besides the hundreds of thousands of stationary engines of all kinds and sizes. From a round 30,000 locomotives he estimates as much as 53,000,000,000 cubic yards of vapor each week, 7,000,000,000 cubic yards a day, all to be returned as rain—"quite enough," he says, "to produce a good rain-storm every twenty-four hours." He estimates other engines of all descriptions at 180,000—probably a very low estimate—and concludes that these, with the locomotives, send about 470,000,000 yards of vapor into the air every seven days. "Is it not enough," he asks, "to give us flood of terror?" Hundreds of gas-wells sending their poison into the atmosphere; millions of cesspools and sewers. Would it be any wonder if some blighting plague would lay waste the land?

### Just a Hammer.

There is a good, handy, one might almost say home-made appliance used in the Hocking Valley Railroad shop at Columbus, Ohio, which was got up by Mr. Wm. Gummere, the air brake expert at that place. The object of the home-made appliance is to straighten brake rods, and hangers, and bent bars of iron or in fact do a thousand-and-one pieces of work where a few smart, well directed blows of a fairly heavy hammer are needed.

The appliance consists of an old driving brake cylinder which has been taken out of road service but has not been thought worthy of being retired from the road altogether. This brake cylinder is bolted in its usual position to a post in the shop and the bottom end of the piston rod is fitted with a circular piece of steel which makes a good hammer head. Under the head is the anvil, supported on a large round block of wood like a section of a wharf pile or the chopping block in a butcher's shop.

From the upper cylinder head or top cover, if you like that name better, a pipe comes off and supports an ordinary plug cock which opens and shuts to let air into the cylinder or exhausts it according as it is moved to application or release positions. The supply pipe above the plug cock runs up to an old feed valve reservoir which has been retired but not pensioned off. Into this reservoir the air supply of the shop is piped. The object of the reservoir above what we must now call the air hammer cylinder is to keep a sufficient quantity of air close at hand to fill the cylinder quickly without making the shop supply pipe gasp for air every time the hammer strikes a blow.

The plug cock is arranged with its handle connected to a long rod which hangs down nearly to the ground, and to this long rod is attached a piece of

3/4-in. pipe which sweeps round the wooden anvil block in a gentle and graceful curve. The curved pipe is hinged at its ends and stands about 3 ins. off the ground, and to make a long story short, the pipe is a treadle.

When it is desired to make the hammer knock brake rods or other crooked material, the operator, hammerman, artificer or laborer, as the case may be, puts a foot on the treadle and presses it down, holding the work on the anvil thewhile. When the plug cock moves, down comes the hammer, and when the pressure of the foot comes off the treadle, the coil spring inside the one-time driver brake cylinder carries the piston up as the air is released and the reservoir above fills up again ready for another blow in more senses than one. All sorts of crooked stuff of light make go up against that hammer and leave it resolved to lead a new life. The hammer is a good, useful thing in its own

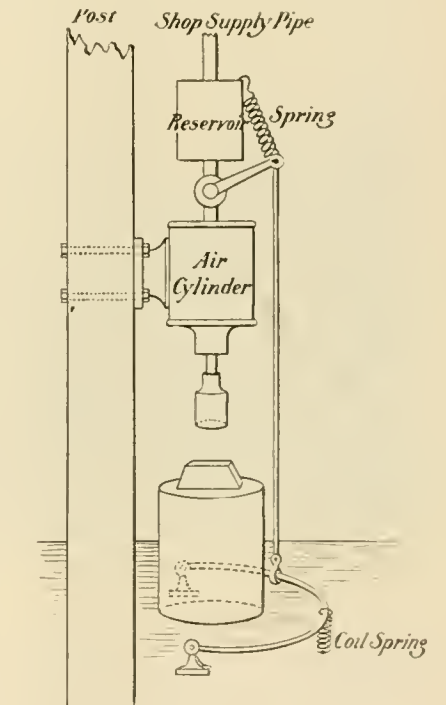

SHOP AIR HAMMER.

line and does a whole lot of work one way and another without calling itself a drop forging machine, or anything else but a home-made air hammer, at your honor's service.

The steamship "Japan" paid a fine of \$1,000 the other day for bringing five passengers from Honolulu, it being contrary to the law for a ship of foreign register to carry passengers between American ports. Immigration Commissioner Sargent, who is well known to all railroad men, was one of the passengers, and he paid his pro rata, \$200. Sargent has always been a self-denying individual. Any other government official would have kicked.

There is a catalogue just off the press which is issued by the Commercial Acetylene Company, of New York. It is not only a catalogue by which parts of the apparatus are described and illustrated, but it is a treatise on the acetylene safety storage system for general railway lighting as carried out by this company. The various uses to which this brilliant illuminant may be put, how it is generated, stored and used, are all taken up and described in detail. The fixtures are illustrated and described not only in the letter press, but are practically on view in a series of half tones of excellent quality. The ground plan of a typical generator and compressor plant, as used on the N. Y., N. H. & H. at Providence, R. I., is shown, together with exterior and interior views of that plant, and the one on the Lackawanna at Hoboken, N. J. The interior views of the latter show the acetylene generators, carbide chamber, hoppers, driers, scrubber and the compressor, and also the storage tanks. The system is not only applicable to car



PIKE'S PEAKER ON THE LEVEL.

lighting, but is used for shop illumination as well, and a practical demonstration of its use in locomotive headlights is also afforded the reader, there being a couple of striking illustrations showing the acetylene headlight on a passenger engine and an old oil headlight on a switcher equipped with the acetylene light. The use of this gas as applied to portable projectors for wrecking purposes and temporary or permanent outside lighting is also given, and a signal bridge in use on one of our leading four-track roads is shown with safety storage cylinder in a convenient position nearby. The second part of the catalogue is devoted to the illustration of the various fixtures, glassware appliances, etc., used in connection with this system. The interior fittings are tasteful and elegant in design and a number and name are appended to each for convenience in ordering. Sectional views of lamps and fixtures are also

given. The catalogue contains a great deal of information and should be in the hands of anyone who is interested in acetylene lighting in any form. The company are to be congratulated on their artistic and useful presentation of the subject and we are authorized to say that the catalogue will be sent free to anyone who is interested enough to apply for a copy.

The Westinghouse Traction Brake Company, of Pittsburgh, Pa., have issued a standard size pamphlet, which can be bound in with others of their issues. It is on straight-air brake equipments for use on trolley cars and interurban equipment generally. It is intended for use on cars which are operated singly. Three very fine plates show the whole arrangement for a car with pipe connections, etc., one being for the SM-1 schedule, the next for the SM-2, and the last for the SM-3 schedule. These three forms of equipment are designed to meet the varying requirements of practice. The arrangement of the apparatus and its operation in each case is the same, but the details differ to suit class of service, convenience of installation, personal taste and price. A description of the apparatus and illustrations of the various parts are also given. Write to the company in Pittsburgh if you desire to have a copy of the pamphlet.

A novel form of what we may call a sort of interrogatory folder has lately come to our office. It is from the Detroit Seamless Steel Tube Company, of Detroit, Mich. We call it an interrogatory folder because on the outside there are simply the words, "Do you know?" and inside each paragraph contains a piece of information for which we have no doubt any Egyptologist would be delighted. Each bit of ancient lore is prefaced by the words which we have quoted from the cover. For instance, "Do you know that the Egyptian alphabet stands to this day as a really scientific method of representing human speech?" Coming down to more modern times there are a few "do you know's" about the seamless cold drawn boiler flue as made by the Detroit company, but the bulk of the information contained in the folder is about the country which George Ade says can be seen thoroughly from the deck of a Nile steamer. We may add a paragraph to the rest, though we will not write it in cuneiform or hieroglyphics. It is, Do you know that the folder can be had for the asking from the company in Detroit? Now you do, and you are entitled to have one.

This illustration shows the form of construction of the  
**Dart Patent Union**

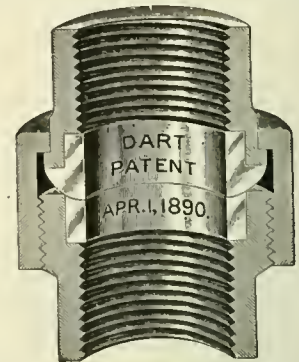

Every feature of construction represents the best points to insure stability and durability. The malleable iron pipe ends and nuts, in combination with bronze metal seats, are as near perfection as is possible to approach, and the sales to date indicate the public approval. There are none as good. For sale by all the principal jobbers in United States, Canada and Europe.

**E. M. Dart Mfg. Co., Providence, R. I.**  
FAIRBANKS CO., SALES AGENTS.



## The Twentieth Century Master Mechanic

Won't use Solid Mandrels.  
Cost too much, take up too much room and don't give satisfaction.

### Nicholson Expanding Mandrels

Take everything from 1 to 7 inch holes. Take up little room—always ready and you can buy four sets for the cost of one of the solid kind.

### Are You Using Them?

Catalogue tells you more about them.

**W. H. Nicholson & Co.**  
Wilkesbarre, Pa.

**STANDARD MECHANICAL BOOKS  
FOR ROAD AND SHOP MEN  
BY CHAS. McSHANE.**

**The Locomotive Up to Date**

Price, \$2.50

**New York and  
Westinghouse Air Brakes**

Price, \$1.50

**One Thousand Pointers for  
Machinists and Engineers**

Price, \$1.50

All books bound in fine cloth.

AGENTS WANTED everywhere; write for terms and descriptive circulars. Will be sent prepaid to any address upon receipt of price.

**GRIFFIN & WINTERS**

171 La Salle Street, CHICAGO

**TOOL  
STEEL**

**Die Blocks  
Steel Forgings**

First Prize awarded at the Louisiana Purchase Exposition, at St. Louis, for our TOOL STEEL when placed in competition with the best makes in England and Germany.

Write for information and Prices. Specify McInnes Tool Steel when ordering.

**McINNES  
STEEL CO.**

CORRY, PA.

**Markam and Close Did Something.**

BY FRED H. COLVIN.

There was a new general foreman in the locomotive repair shops of the P. X. & Q. road. That is, he was new several months ago, and he served to keep tabs on the work without making much of an effort to do so.

One day a bright young machinist came to him and said:

"Mr. Close, I've an idea that ought to save money for the company, and at the same time give us machinists more wages. I'm after the dollars myself, but I know you are not specially interested unless it saves money for the company. May I fire ahead?"

Mr. Close nodded.

"First I want to ask some questions: What does it cost to give an engine a general overhauling?"

Mr. Close didn't answer; wondered what sort of a game it was.

"Well, I know pretty nearly, I guess. About \$2,500, on the average. Am I right?"

Mr. Close nodded. "Pretty near," he said.

"And we are turning out four a month."

Another nod.

"What proportion is labor and what material. About \$1,500 for labor, isn't it?"

"Pretty close to that."

"Then if we increased the output to five a month 'twould save the company \$1,500, wouldn't it? Providing, of course, we used the same tools and equipment and didn't take on any more men."

"Looks that way; but how would you do it? And how would you increase wages any to do that?"

"Couldn't. But if the scheme works and doesn't cost the company a cent wouldn't they divide the saving. Seven hundred and fifty dollars a month clear saving is worth their thinking about."

"Guess you're right, Markham, but I don't know how they'd look at it. Now I won't ask your plan till I see the powers that be. If I can get their agreement we'll try it. But I don't know."

After much correspondence Mr. Close finally received a letter from the general manager saying that "the company will divide evenly net saving over present cost repairs, providing no new equipment is called for and nothing is done to antagonize the men."

Then Markham explained his plan to Mr. Close. The general foreman thought 'twas worth trying and they started in.

It took a month to get it going in good shape, but they beat the regular rate by quite a little.

The second month they turned out five engines and in the course of a few months they were putting out six engines with the same force. Then the general manager came down to see what was doing, as the idea of paying \$1,500 extra wages a month to the men at the Cross Cut shops must be looked into and explained somehow to the directors when they met. So the general manager came down the next day on the mail. Then he went into executive session with Mr. Close.

"Tell me all about it, Close. You've got me into the scrape, now help me out."

"Scrape? Call saving \$1,500 a month on engine repairs a scrape? Should think you'd be tickled to death instead of looking scared over it."

"Yes, but the pay roll or premium, or



PIKE'S PEAK RAILWAY, SHOWING RACK RAIL.

whatever you call it. There it is in black and white, \$1,500 in cold cash as extra wages. What will the directors say to that?"

"Why should they say any more than to the \$1,500 saved? You've simply handed back to the men half of what they saved you. Haven't spent a dollar for new tools, or for more land, or more buildings. It's simply a case of working the men more efficiently, and the company gets half the saving."

"Well, Mr. Close, I don't know how they'll look at it. If they've got horse sense they'll say it ought to be adopted all over the road. Now, I'll tell you what. That meeting is next Tuesday. You come down to headquarters on number 10 and tell the directors yourself—that's how I'll get out of it."

"I'll be there and bring Markham, as it's his scheme—not mine."

The directors' meeting was on. When

the general manager came to the part of the report that involved the Cross Cut shop change, he spoke thusly:

"We have a peculiar situation at the Cross Cut shops. Our former capacity was four locomotives overhauled per month. By a plan suggested by a machinist named Markham, we have increased this to six engines a month. There has been no piece work adopted, no change in the shops or tools, no additional cost in the way of equipment.

"Our previous running expense was approximately \$10,000 per month, \$2,500 per engine. Of this, about \$1,500 per engine was for labor. The running expenses are now \$13,500 per month, but dividing this up among the whole six engines it reduces the cost \$250 per engine or \$1,500 per month.

"Several months ago Mr. Close, our general foreman at those shops, sprung a proposition on me to divide the net saving in labor between the men and the company. I thought it over and came to the conclusion that if Mr. Close could increase the output of the shops without adding to the equipment or causing labor troubles, he better go ahead. The transportation department is always calling for power and every day a locomotive is in the shop means a loss in profit bearing traffic, so that we should really add quite a little to the saving in the shop expense. In addition to the saving of \$1,500 per month over the cost of repairing six locomotives at the old rate; is the use of the engines during the time they would otherwise be in the shop.

"If you approve the plan, in spite of apparently additional payment of wages, I shall introduce it into the other shops of the system.

"Mr. Close will tell you how he did it."

Mr. Close and Markham appeared, but as Markham was bashful, Close told the story, after the usual preliminaries.

"It's a simple plan. So simple that I wouldn't believe it would work. When Markham proposed it I was skeptical. He got the idea somehow or other and ought to have some recognition, and I hope he'll get it. He didn't know I was going to say that.

"When we started I called the men together and we had a little talk about as follows:

"One of your shopmates has an idea that we both hope will help things in the shop in every way. 'Tisn't a piece work game of any kind, and there will be no change in working hours or wage rate. We are now turning out four engines a month, and that will be our basis for all work. I have the general manager's agreement that if we increase this rate half the saving in labor cost will be given to us. At the present time the labor cost per engine is about \$1,500. If we turn out five engines a month we have \$750 to di-

vide among the men of this shop. This we will divide according to the wage scale of each man and boy who has anything to do with the work. This means the whole force of men here, office and shop. This also means that every man must do his best, must help each other, as in so doing you are helping along the work. We don't need any spotters or inspectors, as each man will see that the work is right, so he can do his part. There are no penalties except that the work must not fall below the present rate of four engines per month. If this works as we hope, there will be a neat little sum of extra money coming to each man every month, and there will be no cut in the rate of wages.'

"And, gentlemen, it worked. After it got going smoothly and the men got over being afraid of some put-up job, the whole shop began to ginger up on work. Every man kept tabs on his neighbor and a little good natured joking generally served to hurry up the slow ones. A few who wouldn't try were made so uncomfortable they quit. I'd have had to fire them if they hadn't to keep peace in the shop.

"Every one, from the office boy to the valve-setter, is interested in getting out as much work as possible, for the simple reason that it means dollars in his pocket and, though this doesn't interest him quite so strongly, it means dollars for the road.

"Markham's plan beats straight piece work for our shop, as it does away with all rate setting and the difficulty of having some classes of work pile up if certain men happen to be faster than others. This plan pushes along the whole work and I believe it's the best for any general work.

"It isn't only that the men work harder, but they plan out little devices for helping the work along, knowing that it means money in their pocket, and money is what urges us all on.

"I would suggest that Mr. Markham be appointed 'Cost Reducer,' or anything you want to call it, to introduce this plan into the other shops of the system."

"Second the motion," said the general manager.

"Moved, seconded and carried unanimously," said the chairman, and the meeting adjourned.

Messrs. Markham and Close did something.

Executive officers of the Western railroads have agreed not to issue any passes or reduced rate tickets to officers or employes of industrial roads that handle solely the traffic of industrial concerns which also own the railroads. The railroads also agreed not to exchange passes with minor steamboat lines.—*New York Commercial*.

## One Year and Eleven Months' SERVICE

WITHOUT REPACKING, ON

### High-Pressure Locomotives

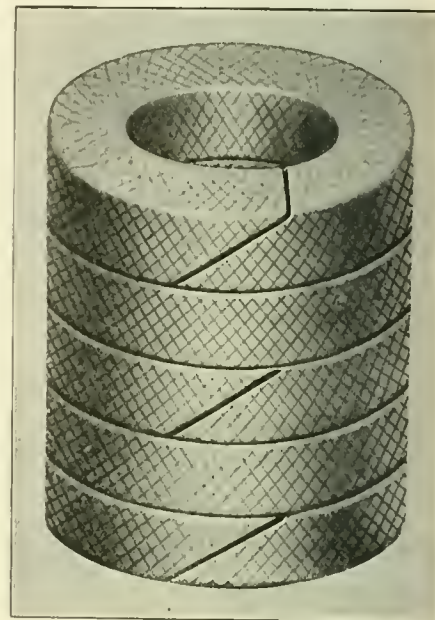

Style 300 TV.

A throttle failure is an absolute impossibility where Crandall's Throttle Valve packing is used:

IT WILL NOT BLOW OUT

## Crandall Packing Co.

FACTORY AND GENERAL OFFICE

PALMYRA, - - NEW YORK

BRANCHES

New York  
136 Liberty St.

Cleveland  
9 So. Water St.

Chicago  
52 West Washington St.

## Patents.

GEO. P. WHITTLESEY

McGILL BUILDING WASHINGTON, D. C.  
Terms Reasonable Pamphlet Sent

## Molding Machines

Vertical Vibration Power Draft  
ALL KINDS OF MACHINES

THE E. H. MUMFORD CO.  
17th & Callowhill Streets, PHILADELPHIA, PA.  
J. W. JACKMAN & CO., Ltd., 39 Victoria St., London, S. W.

**CYLINDER  
BORING BARS  
VALVE SEAT  
ROTARY  
PLANING MACHINES  
CRANK PIN  
TURNING MACHINES**

*Write for Catalog*

**QUINCY, MANCHESTER SARGENT CO.**  
 OLD COLONY BLDG. 114 LIBERTY ST.  
 CHICAGO NEW YORK  
 Machinery Sales Dept.  
 PLAINFIELD, N. J.

**A Word Concerning Cranes.**

There is a curious little word "gaun," and it means, according to provincial English usage, a small tub, and the original wooden frame used in holding or lifting it was signified by the word tree, just as in many another like case, as, for example, roof-tree, for the wooden rafter of a house. The gaun-tree was therefore the wooden frame for lifting the little tub or barrel. In time the word came to be shortened into gantry, and the meaning has gradually undergone further change until at the present time it designates something which has no wood about it and is used for lifting almost anything you like perhaps, except a small tub.

A good example of the modern gantry, where wood is not used and tubs are not lifted, may be found in the recently issued catalogue of the Whiting Foundry Equipment Company, of Harvey, Ill. There the movable frame of steel wrought into practically bridge construction and lifting heavy blocks of marble may be seen, with its 160 ft. girder and a capacity rated at 50 tons. Such an equipment is electrically driven by five motors and there are two trolleys. The old wooden barrel lifter is now the electric traveling gantry crane of the modern supply company.

Other cranes are shown, such as the four-motor electric traveling crane, two of which, with their 60 tons capacity each, can dangle a locomotive in the air and sail with it from one end of a railroad repair shop to the other. Then there is the transfer crane in a railway yard, spanning two or more tracks, and used for lifting heavy pieces of machinery or other merchantable goods from one car to another or simply used for loading or unloading freight. Then there is the pillar crane, operated by hand or electricity or air, and the bracket crane, stationary, and the bracket crane, traveling, also the jib crane. Lastly, there is the electric transfer table, which is practically the traveling crane set on the ground.

There is a much larger variety of the crane family, ranging from the light jib to the ponderous gantry, than one would ordinarily suppose. The complete crane catalogue issued by this company is No. 45 and illustrates over one hundred important installations and describes them as well. Next month we are going to have some observations on a simple method of calculating the stresses in a jib crane. Write to the Whiting Foundry Equipment Co. for catalogue No. 45 and you will be able to see what the various kinds of cranes are like, and then you may read our article in March more understandingly.

**Circular Cut File.**

An English firm has recently placed on the market what is called a circular cut file, which is said to be very efficient, and for its form the claim is made that it has self-cleaning properties. The file is flat and the teeth are not cut straight across the face of the file, but each tooth forms the segment of a circle of considerable radius, and the teeth are cut very deep. The crown or highest part of the segment is in the center of the file face, so that as it is pushed forward over a piece of work there is a natural tendency for the filings to work out at each side. This is the explanation of the self-cleaning properties which the file is said to possess. It can be used on all metals, including iron, brass and aluminum. The file can be re-cut four times and is said to last longer than a file of ordinary make. This form of file cutting has been patented.

The work of double tracking the Louisville & Nashville from the junction of the Kentucky Central and the Louisville and Knoxville divisions at Sinks to the junction of the Cumberland Valley and Louisville and Knoxville divisions at Corbin, a distance of 35 miles, is now being pushed in earnest.—New York Commercial.

**CONTENTS**

	PAGE.
*Niagara Canyon Trestle.....	51
Steam Boilers, By Angus Sinclair.....	52
Haste to Save a Work Train.....	55
Jim Skeever's and a Gentleman.....	57
*General Correspondence .....	59
Railroading as a Business.....	62
*Scientific Invention Practically Applied....	63
Locomotive Water Tube Boiler.....	63
Railroad Equipment in the U. S.....	63
Cycloid Curves .....	63
Hudson Company's Tunnel .....	64
*Patent Office Department.....	65
Book Notices .....	69
*Correspondence School .....	71
Questions Answered .....	75
*Air Brake Department.....	75
*Electrical Department .....	78
High Steam Pressures.....	80
*Shop Kink Prevents Kinks.....	82
*Ideal Track .....	88
Harnessing Victoria Falls.....	90
*Chicago Midget Drill.....	92
*Just a Hammer .....	93
Markham and Close Did Something.....	95
Locomotives:	
*Mexican Central Oil Burner.....	54
*Passenger 4-4-0 for Japan.....	58
Mummied Engines Not Wanted.....	58
*4-4-0 Engines for Java.....	70
*Baldwin Engines for Italy.....	81
Editorials:	
Clearinghouse Idea in Car Service.....	66
Surprise Tests .....	67
Headman or Induna .....	67
Duty of a Doctor.....	68
Matterhorn Railway .....	68
Easily Made Repairs.....	68
Soft Hammers .....	69
Pennsylvania Railroad Tubes.....	69
Cars:	
*Private Car for Western Union.....	56
*Motor Car on the U. P.....	89



**SKAT!**  
Off  
Comes  
the Dirt.

When the hands are smeared and stained with a greasy grimy coat of oil, soot, dust and dirt, rub on a little

**SKAT**

**The Best Hand Soap Known**

and see how quickly they're clean and soft again. SKAT is made to do what ordinary hard soaps can't do. Gets into the pores and loosens all the dirt so it simply rinses off. Pure, effectual and beneficial to the skin. 10 cents a can.

Write postal for free sample and we will tell you where to buy SKAT, or if not sold in your locality, will tell you how you can become our exclusive agent and make money selling it. Write to-day.

**THE SKAT MANUFACTURING CO.,**  
807 Park Street, Hartford, Conn.

**Speed Regulations.**

The speed limit regulations affecting automobile traffic seem to reach out and touch railway operation in the smaller towns of Pennsylvania. Recently at Wilkes-Barre a crew on the Black Diamond express on the Lehigh Valley Railroad was fined for exceeding the speed limit established by the passage of some new ordinance. The lawyers for the road claimed that if every town and borough along the line adopted similar regulations an express would take nearly three days to run to New York. It will be remembered that on the establishment of the first railway through England the wise men of the town of Nottingham passed an ordinance forbidding the railroad to come within six miles of their ancient burgh.

The term "spick and span" was derived from the practice of stretching a new piece of cloth on spikes (hooks) and spans (stretchers) in order to stretch it evenly.

S  
A  
V  
E



D  
O  
L  
L  
A  
R  
S

WEARWELL  
LEATHER PACKINGS

Save dollars for you. They reduce your cost of maintenance and increase the efficiency of your machines. Write for descriptive booklet and sample.

ALL  
SIZES



ALL  
STYLES

DETROIT LEATHER SPECIALTY CO.  
60 Beecher Avenue      DETROIT, MICHIGAN

# Development of the Locomotive Engine

By **ANGUS SINCLAIR**

This book is on the press and will be ready in a few weeks. It represents an immense amount of difficult research and contains data that will not be available after a few old pioneers still living pass away.

The book is the Standard Master Car Builders, 6½ x 9 inches, and contains about 700 pages. It is very profusely illustrated and gives a graphic story of the locomotive by pictures alone. The price is \$5.00.

---

## Railway and Locomotive Engineering

136 Liberty Street, New York

**INDEX TO ADVERTISEMENTS.**

	PAGE.	
Acme Machinery Co.....	Front Cover	
Air Brake Chart.....	13	
Ajax Metal Co.....	4th Cover	
American Balance Valve Co.....	4th Cover	
American Brake Shoe Co.....	8	
American Loco. Sander Co.....	91	
American Locomotive Co.....	2	
American Locomotive Equipment Co.....	4th Cover	
American Steam Packing Co.....	7	
Armstrong Bros. Tool Co.....	2d Cover	
Armstrong Mfg. Co.....	7	
Audel, Theo., Co.....	8	
Automobile Magazine.....	7	
Baker, Wm. C., Heating and Supply Co.....	8	
Baldwin Locomotive Works.....	3	
Ball Webb, C., Co.....	87	
Barnett, G. & H., Co.....	2d Cover	
Bettend of Axle Co.....	17	
<b>BOOKS:—</b>		
Development of Locomotive Engine.....	10	
Miscellaneous Books.....	18	
Twentieth Century Locomotives.....	10	
Bordo, L. J., Co.....	93	
Carpenter, The J. M., Tap & Die Co.....	3	
Chalfonte Hotel.....	1	
Chapman Jack Co.....	6	
<b>CHARTS:—</b>		
Air Brake Chart.....	13	
Locomotive, American Type.....	17	
Chicago Pneumatic Tool Co.....	13	
Cleveland City Forge & Iron Co.....	4th Cover	
Cleveland Twist Drill Co.....	4th Cover	
Climax Bearing Co.....	4	
Commercial Acetylene Co.....	21	
Commonwealth Steel Co.....	11	
Consolidated Railway, Electric Lighting & Equipment Co.....	7	
Crandall Packing Co.....	96	
Dart, E. M., Mfg. Co.....	94	
Davis, John, Co.....	20	
Detroit Leather Specialty Co.....	98	
Detroit Lubricator Co.....	8	
Detroit Seamless Tubes Co.....	17	
Dixon, Joseph, Crucible Co.....	85	
Falls Hollow Staybolt Co.....	15	
Fay & Egan Co., J. A.....	23	
Flanders, L. B., Machine Works.....	13	
Flannery Bolt Co.....	90	
Franklin Mfg. Co.....	11	
Frost Railway Supply Co.....	2d Cover	
Galena Signal Oil Co.....	25	
Garlock Packing Co.....	4	
General Electric Co.....	1	
Gold Car Heating Co.....	86	
Goodrich Rubber Co.....	20	
Gould Coupler Co.....	3	
Greene, Tweed & Co.....	2d Cover	
Griffin & Winters.....	95	
Hammett, H. G.....	4th Cover	
Hancock Inspirator Co.....	—	
Hendrick Mfg. Co.....	3	
Henley & Co.....	88	
Hicks, F. M., & Co.....	15	
Hoffman, Geo. W.....	3	
Homestead Valve Mfg. Co.....	91	
Hotel Rudolf.....	4	
Hotel Traymore.....	14	
Hunt, Robert W., & Co.....	91	
International Correspondence Schools.....	89	
Jenkins Bros.....	4th Cover	
Johns-Manville, H. W., Co.....	11	
King-Lawson Car Co.....	24	
Kinnear Mfg. Co.....	2d Cover	
Latrobe Steel Co.....	—	
Latrobe Steel & Coupler Co.....	7	
<b>LOCOMOTIVE CHARTS:—</b>		
American Type.....	4	
Locomotive Publishing Co., Ltd.....	13	
Long & Allstater Co.....	6	
Magnus Metal Co.....	10	
Manning, Maxwell & Moore.....	17	
McConway & Torley Co.....	4	
McCord & Co.....	2d Cover	
McInnes Steel Co.....	95	
Morse Twist Drill Co.....	6	
Mumford, The E. H., Co.....	96	
Nathan Mfg. Co.....	15	
National Acme Mfg. Co.....	14	
National Malleable Castings Co.....	4th Cover	
New Jersey Asbestos Co.....	10	
Nicholson, W. H., & Co.....	94	
Niles-Demont-Pond Co.....	9	
Norwalk Iron Works.....	15	
Pittsburgh Crushed Steel Co.....	4th Cover	
Pittsburgh Spring & Steel Co.....	16	
Porter, H. K., & Co.....	2	
Pratt & Whitney.....	—	
Pressed Steel Car Co.....	7	
Prosser, Thos., & Son.....	10	
Quincy, Manchester, Sargent Co.....	97	
Railway Materials Co.....	2d Cover	
Railway Steel Spring Co.....	17	
Ralston Car Co.....	19	
Revere Rubber Co.....	3d Cover	
Rogers, H. A., Co.....	22	
Rogers Locomotive Works.....	2	
Rue Mfg. Co.....	3	
Safety Car Heating & Lighting Co.....	9	
Saunders, D., Sons.....	15	
Sellers, Wm., & Co., Inc.....	1	
Sight Feed Oil Pump Co.....	14	
Skat Mfg. Co.....	97	
Smooth-On Mfg. Co.....	11	
Standard Car Truck Co.....	2d Cover	
Standard Coupler Co.....	8	
Standard Paint Co.....	87	
Standard Steel Works.....	3	
St. Louis Car Co.....	16	
Star Brass Mfg. Co.....	6	
Starrett Co., L. S.....	16	
Storrs Mica Co.....	94	
Symington, T. H., & Co.....	4	
Tabor Mfg. Co.....	5	
The Tanite Co.....	92	
Underwood, H. B., & Co.....	13	
Union Switch & Signal Co.....	92	
United States Metallic Packing Co.....	20	
Vacuum Cleaner Co.....	9	
Vanduzen Co.....	22	
Vulcan Iron Works.....	2	
Walker, A. Fenton.....	4	
Walworth Mfg. Co.....	2d Cover	
Washburn Co.....	4th Cover	
Watson-Stillman Co.....	4th Cover	
Westinghouse Air Brake Co.....	12	
Westinghouse Electric & Mfg. Co.....	13	
Whiting Foundry Equipment Co.....	5	
Whitlesey, Geo. P.....	96	
Williams Typewriter Co.....	15	
Wood, R. D., & Co.....	6	
Zephon Chemical Compound Co.....	11	

# Railway and Locomotive Engineering

Copyright by Angus Sinclair Co.—1907

## A Practical Journal of Railway Motive Power and Rolling Stock

Vol. XX.

136 Liberty Street, New York, March, 1907

No 3

### The Rotary in the Rockies.

Science vs. brute force may be said to be the motto of the rotary plough in railroad service. Snow conditions this year on the northern transcontinental lines are perhaps the worst that have

in keeping a railroad track open and clear in the winter.

The rotary will remove snow of any degree of hardness or weight and of any depth. It does the work quickly and easily, with no danger to the equip-

drifts packed in a hard, icy mass with perfect safety to those operating. Except in presence of very exacting conditions, one heavy consolidation locomotive provides sufficient power for its propulsion.



ROTARY SNOW PLOW ON THE DENVER, NORTHWESTERN & PACIFIC RAILWAY.

been experienced in ten years, and in January and February the rotary snow-plow was one of the most important features of the equipment of those roads. These mechanical snow fighters have played an important part in the history of railroading in the West, and have not only surpassed but have superseded the old-fashioned wedge plow

ment or the men employed. To cope with drifts 15 to 20 feet high, something besides brute force is required. The old method of bucking drifts of this kind with the wedge plow pushed by several heavy locomotives, resulted in many casualties among the railroad men engaged in the dangerous work. The rotary will bore its way through

The Rotary illustrated in our frontispiece this month is the largest ever built. It was recently completed at the Cooke Works of the American Locomotive Company, for the Denver, Northwestern & Pacific Railway. The main wheel consists of ten cone-shaped scoops fitted with knives which adjust themselves automatically to the

cutting position. The wheel which drives out the snow is like a paddle wheel and is encased in a drum, and the drum is provided with a reversible hood, operated by an air cylinder, so that the hood may be turned to either

ing wheel of this plow is 12 ft. in diameter, the extended hood is 15 ft. in diameter, which allows the rotary to cut a 15 ft. opening. The hood is set about 15 ins. in advance of the wheel, and cuts the snow and forces it into the revolving wheel.

plow when compared with the headlong rush of the old-fashioned wedge plow plunging at full speed into a heavy drift. One might almost say the old plough had a devil-may-care disregard of consequences, as it made a bold push at the mountain of snow ahead. We remember some years ago seeing the picture of a snow plow train on a Western road ready for active service or going to the front as if for war against the elements. The train as it stood with plow in front, in regular fighting trim, pushed by "three Schenectady compound hogs," was the complete embodiment of force. After a successful dash the plow was again run through the beaten drift with nose down and wings out to complete the victory. There was something spectacular and dramatic in the performance.

In contrast with this, the old way, the work of the rotary appears. There is no headlong rush, but there is no second drive against the drift, for the work is finished as the plow slowly forges through. It is applied science accomplishing the desired end, fully, powerfully, without haste, but with the steady endurance of the trained fighter. This is not to say that great force is lacking.

In speaking of this aspect of the work, Mr. Thompson tells us that "to hold the rotary up against the snowdrifts on a 4 per cent grade it requires



THE ROTARY SNOW PLOW DOING BUSINESS.

side to suit the the direction in which the wheel is turning. Snow can thus be thrown out on either side of the track. The boiler used in the plow is of the locomotive type, 67 $\frac{3}{8}$  ins. in diameter, with Belpaire firebox and carries a pressure of 190 lbs. The engine consists of two horizontal cylinders with slide valves operated by the Walschaerts valve gear. The plow is carried on a steel I-beam frame, and this is mounted on two 4-wheel steel frame trucks. In order to prevent the derailment of the plow, the front truck is provided with ice cutters and flangers. These ice cutters are attached to a frame hung on the forward end of the front truck. They are raised by means of an air cylinder, so as to clear frogs or switches, and are lowered by the same means when the plow is working along the road. Flangers are hung in the rear of the truck, and are also operated by an air cylinder. With the ice cutter and flanger in perfect working order, it is impossible for the rotary to be derailed by ice or snow.

One of our illustrations shows the snow cut made by one of these plows and the clear rail which is left behind it. The rotary has been used on most of the important railroads for the past twenty years, and the successful operation, in winter, of many of the lines crossing the Rockies has depended upon these mechanical devices for fighting the snow.

In this connection, Mr. George Thompson, superintendent of motive power of the Denver, Northwestern & Pacific, writing to RAILWAY AND LOCOMOTIVE ENGINEERING, says: "The revol-

The machine will advance about 2 miles per hour through a 15 ft. drift. The total weight of the rotary plow is 176,000 lbs., resting on two 4-wheel trucks with journals 7 $\frac{1}{2}$  x 10 ins. The tank when loaded weighs 136,000 lbs. The wheel



ROTARY SNOW PLOW READY FOR WORK.

is driven by two cylinders 18 ins. in diameter, 26 in. stroke. This rotary runs every day through the winter excepting Sundays. We have added a second rotary to our equipment, which has not been placed in service yet."

There is a sharp contrast in the slow and steady performance of the rotary

the united effort of two consolidation engines with cylinders 22 ins. x 28 ins., steam pressure 210 lbs., and driving wheels 55 ins. in diameter. The rotary snowplow has a crew of three men, consisting of an engineer, pilot and fireman. The pilot rides in the front part of the machine on a platform imme-



diately behind the wheel, where there are peep holes for him to see ahead. He signals the locomotive and the rotary engineers by blasts of the whistle when he is approaching snow banks or other obstructions on the track. We never attempt to strike a snow bank at a greater speed than 4 miles an hour. Bucking snow in the Rocky Mountains under the most favorable conditions is a very strenuous job. When the wind is blowing 45 to 50 miles an hour, and the thermometer 20 to 30 degrees below zero, you can imagine that clearing the track at an elevation of 10,000 to 11,000 feet is about all human endurance can stand. There is no more magnificent sight to be seen than one of these machines working its way through a large snowdrift on a 4 per cent grade while climbing the mountains."

In clearing a mountain road of heavy snow this is the triumph of science, for "the race is not always to the swift, nor the battle to the strong."

#### Steel Making.

Iron making on a large scale was introduced into Britain by the Romans, and it is a remarkable circumstance that in several districts where extensive iron beds exist and which were unknown to Englishmen until about fifty years ago, bear strong evidence that the Romans were acquainted with them. The art was lost after the Roman occupation of Britain ceased, and in the reign of Edward III, iron was so rare that pots, spits and frying pans were then classed as the king's jewels.

These facts and many others of a like interesting and instructive character were brought out in a paper recently read by Mr. W. E. Symons before the Southern and Southwestern Railway Club. About 1620 Dud Dudley smelted iron with coal, but the secret died with him, and it was not until the early part of the eighteenth century that the method was permanently established. In 1784 Cort introduced his method of refining pig iron in the puddling furnace and rolling the puddled balls into bars. In 1823 James Meilson recommended the use of the hot blast.

In 1885 a revolution in the art was effected by the invention of the Bessemer process. In speaking of the open-hearth basic process, Mr. Symons says, the object of the basic lining was to enable common pig iron containing phosphorus and sulphur to be used. The fixed lining of calcined dolomite and tar, and the addition of lime to the charge causes a highly basic slag to be formed which takes up the phosphorus and sulphur as well as the silicon.

Wrought iron is made by melting pig iron in contact with iron ore, and burn-

ing out the silicon, carbon and phosphorus and leaving the metallic iron. The temperature of the furnace is not sufficient to keep the iron fluid after the carbon had been burned, and the product comes out as a pasty mass mixed with slag. This is squeezed and rolled until most of the slag is worked out. Bars so made are rough and full of flaws. This muck bar is cut up and "piled" and is heated to the welding point and again rolled. This is practically the merchant bar iron of commerce.

In olden time all kinds of steel con-

Most of the hard steel in the market to-day is made in the open-hearth furnace. Crucible steel is made by putting into a crucible a proper mixture of scrap, pig iron or charcoal, and melting the mass, the crucible being tightly closed against air. This kind of steel is free from minute imperfections and watch springs, razors and needles are made of crucible steel.

The Bessemer process consists in blowing cold air through melted pig iron. In early times the lining of the converter was made of silicious rock and clay. This is the universal practice



SNOW CUT BORED OUT BY THE ROTARY PLOW.

tained carbon enough to make it suitable for cutting tools when hardened in water. The metal turned out of the converter was rightly called Bessemer steel, as in the early days of this process the metal was more or less hard and much of it was used for tools. Current usage here and in Great Britain described "wrought iron" as the product of the puddling furnace or the sinking fire, and "steel" was the product of the "cementation" process, or the malleable compounds of iron made in the crucible, the Bessemer converter or in the open-hearth furnace.

in America. In other countries the linings were often made of basic material whereby the chemistry of the operation was changed. The old way, that used in America, is called the acid process, and the other the basic process.

In the acid process the air passing through the molten iron burns the silicon and carbon, and the burning of the silicon supplies most of this heat. With the basic process this lining in the converter is limestone, containing from 30 to 40 per cent of magnesia. In this process the percentage of silicon in

the iron is kept as low as possible, and consequently another source of heat must be found. This is the phosphorus. In the acid process phosphorus was not eliminated but it is in the basic process by the addition of lime.

An open-hearth furnace is one having a hearth exposed to the flame. A regenerative furnace is one in which the heat carried away in the stack is used to warm air and gas before they enter the furnace. The term acid open-hearth furnace means a regenerative gas furnace used for melting steel, and it is lined with silicious material (sand). In the acid open-hearth process a mixture of pig iron and scrap is charged into the furnace and melted, nothing is added to form a slag, as the combustion of silicon and manganese, together with some iron that is oxidized and some sand from the bottom affords a sufficient supply. When the mass is melted it is fed with iron and the oxygen in the ore oxidizes the excess of carbon until the required composition is attained, whereupon the steel is tapped, the proper additions of manganese being made at the time of tapping.

The term basic open-hearth furnace means a regenerative gas furnace used for melting steel and usually lined with

lime or limestone added. The iron, scrap and lime are melted. The silicon and carbon of the pig are oxidized as in the acid process. The manganese

#### First Great Railroad Accident.

The first great accident on any railroad occurred December 24, 1847, on the Great Western railway in England



RAILROADING IN THE ROCKIES, WHERE THE ROTARY WORKS.

of the scrap and some of the iron are both oxidized just as on the sand bottom, but the silica and the manganese do not make a slag by themselves for they unite with the lime that has been added. This gives a basic slag and the phosphorus in the pig iron and scrap will be oxidized and form phosphate of lime or phosphate of iron. The basic open-hearth furnace allows the purification of iron containing phosphorus. For the same reason sulphur in less measure can also be eliminated. After the pig iron and scrap is melted, iron ore is added as fast as necessary to oxidize the excess of carbon, and when the metal has reached the desired composition it is tapped into the ladle, the addition of manganese being made in the same manner as in the acid furnace.

We have been informed that the Paris and Orleans Railway of France has specified the use of Falls Hollow staybolt iron for the boilers of twenty De Glehn compounds which are now being built at the Baldwin Locomotive Works. The supply company's works are at Cuyahoga Falls, O.

That day a train carrying thirty-eight passengers was moving through a thick fog at a high rate of speed. A mass of earth had slipped down from the slope above and covered one of the rails to the depth of two or three feet. The engine plunged into this and was immediately thrown from the track, and instantly the whole rear of the train was piled up on the top of the first carriage, which contained all the passengers, eight of whom were killed and seventeen wounded. The coroner's jury rendered a verdict of "Accidental



ROTARY SNOW PLOW BLADE.

death in all the cases and a deodand of £1,000 on the engine, tender and carriages." This feature of "deodand" belongs to the old common law of England, which declared that whenever any personal chattel was the occasion of death it should be forfeited to the king, not only that part which immediately gives the wounds but all things which move with it are forfeited. Down to 1847, when parliament abolished the practice, coroner's juries in England always assessed a deodand against the locomotive involved in an accident, which, of course, the company had to pay as a fine. Deodand literally means "to be given to God," and originally the fines were handed over to the king's almoner for pious and charitable uses.

The currency of kindness is cash in any country.



ROTARY SNOW PLOW HEAD ON.

magnesite or burned dolomite (limestone with magnesia). The charge for the furnace is pig iron and scrap with

**Compound for the Mexican National.**

The National Railway of Mexico recently received a balanced compound Pacific type locomotive from the Baldwin Locomotive Works. The principal features of the designs are shown in our illustration. The cylinders of this engine are all in the same horizontal plane; therefore, as all the pistons are connected to the second pair of driving wheels, the inside main rods have been bifurcated in order to clear the leading axle. The front end of the rod is provided with lips which bear against the body of the stub, thus relieving the stub bolts of shear. The wrist pin brass is split and is provided with a wedge adjustment. The

of as tandem connected valve gear. The crank axle is built up of seven pieces. The crank cheeks are circular and the central member in the built up arrangement is of cast steel. The frame centers are 44" apart, but between the main driving wheels this is increased to 45 $\frac{1}{2}$ " in order to secure a journal 10" long between the crank cheek and the face of the wheel hub. The Rushton trailing truck with outside journals is used on this engine. In this truck the axle box is rigidly held between the pedestals, and the cast steel equalizer, or spring seat, is suspended directly on spring links. The bearings for these spring links are bolted to a supplemental frame, which is secured to the main frame by means

front, as the firebox is 75 $\frac{3}{4}$  ins deep at the front and 61 $\frac{3}{4}$  ins at the back. The crown sheet and roof sheet slope upward to the front, and as the second course is taper, the dome stands on the highest part of the boiler and is thus designed to secure dry steam for the throttle.

The tender is made with a cylindrical or Vanderbilt tank, which is carried on the usual structural steel frame and arch bar trucks. The water capacity of the tank is 7,500 gallons and the fuel space holds 12 tons of coal. Some of the principal dimensions are appended for reference:

Boiler—Material, steel, diameter, 70 ins.; thickness of sheets 11/16 and 3/8 ins.; fuel, soft coal; staying, radial.

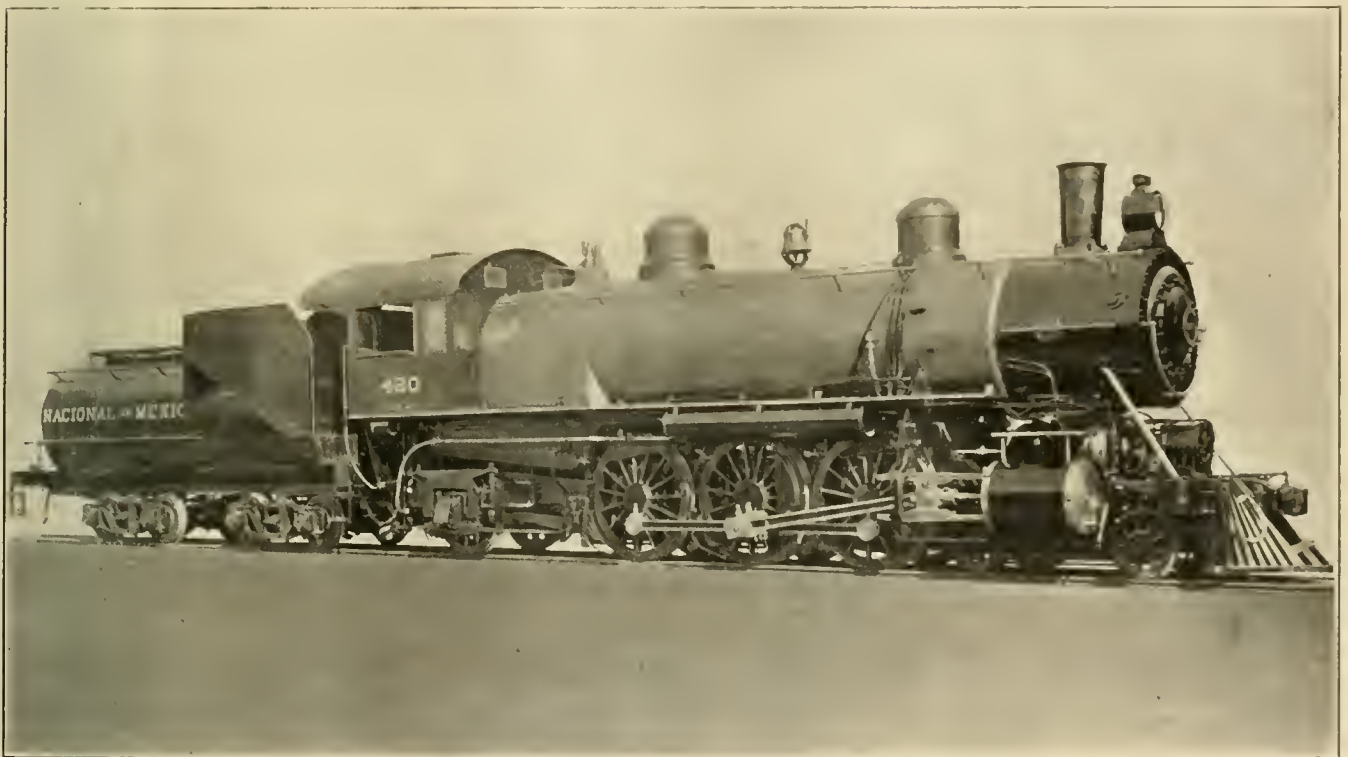

BALANCED COMPOUND FOR THE MEXICAN NATIONAL.

M. J. Schneider, Supt. of Motive Power and Machy.

Baldwin Locomotive Works, Builders.

back stub is fitted with the usual strap and key.

The cylinders are 17 and 28 by 28 ins., and with a boiler pressure of 220 lbs., and driving wheels of 67 ins. in diameter, the calculated tractive effort amounts to 35,720 lbs. With a weight of 147,000 lbs. on the drivers the factor of adhesion is 4.11. Each pair of cylinders is provided with one piston valve, which is driven by the Stephenson link motion. The eccentrics are placed on the third driving axle. The valve rods are necessarily long, supported at two intermediate points and are provided with knuckle joints. The arrangement of valve gear with eccentrics on one axle and driving cranks on another is sometimes spoken

of cast steel brackets. The driving wheel base of the engine is 12 ft., and the total is 33 ft. 11 ins. With tender added, the entire wheel base becomes 62 ft. 11 ins. The engine itself weighs 227,340 lbs., the forward truck carries 45,300 lbs., and the rear truck 35,000 lbs. The weight of engine and tender together is 370,000 lbs.

The boiler is of the wagon top type, with the taper course forward of the dome. The firebox is 113 $\frac{1}{2}$  x 66 $\frac{1}{4}$  ins. and has a grate area of 52.1 sq. ft. The heating surface is made up of 186 sq. ft. in the firebox, 3,527 in the tubes, giving a total of 3,713 sq. ft., and the ratio of grate area to heating surface is as 1 to 67.

The grate slopes down toward the

Firebox—Material, steel; thickness of sheets, sides, 3/8 in.; thickness of sheets, back, 3/8 in.; thickness of sheets, crown, 3/8 in.; thickness of sheets, tube, 1/2 in.

Water Space—Front, 4 $\frac{1}{2}$  ins.; sides, 4 ins.; back, 4 ins.

Tubes—Wire gauge, No. 12; number 301; diameter, 2 $\frac{1}{4}$  ins.; length, 20 ft. 0 ins.

Driving Wheels—Journals, main, 11 x 10 ins.; journals, others, 9 x 12 ins.

Engine Truck Wheels—Diameter, front, 30 ins.; journals 6 x 10 ins.; diameter, back, 48 ins.; journals, 8 x 14 ins.

Tender—Wheels, diameter, 33 ins.; journals, 5 $\frac{1}{2}$  x 10 ins.; service, passenger.

Without a love for books the richest man is poor; but endowed with this treasure the poorest man is rich. He has wealth which no person can decrease in any degree.

Patent Office Department.

FEED-WATER HEATER.

Mr. J. Fournia, Albany, N. Y., has designed and patented a means for heating feed water to locomotive boilers. No. 842,777. The device consists of a box placed along each side and across the rear end of the tank as shown in the accompanying illustration. A coil of pipe placed in the box



FEED WATER HEATER.

extends throughout its entire extent, a pipe connects the lower layer of the coil with the bottom of the tank, and means for connecting the upper layer of the coil with the locomotive boiler, and a steam conveying pipe connecting the interior of the box to the engine forward of the boiler and an adjustable valve in the steam pipe.

TRUCK BOX.

A truck box furnished with an improved lubricating device for car axle journals has been patented by Mr. F. B. Harrison and Mr. L. V. Williams, Toledo, Ohio, No. 841,380. The contrivance embraces a combination with a journal box, having recesses in its sides open to the inside of the box and springs within the recesses. An adjustable pan is placed under the axle and the pan is supported by springs resting on the bottom of the box. The springs are held in place by posts.

EXHAUST NOZZLE.

Mr. P. B. Houghton, Carpenter, S. D., has patented a flexible exhaust nozzle. No. 841,462. It comprises an exhaust nozzle including an elbow hav-

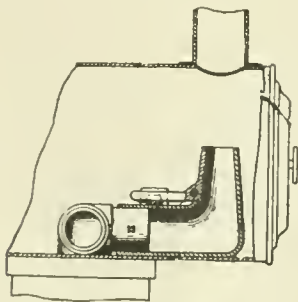

EXHAUST NOZZLE.

ing its discharge end open and provided with a longitudinal slot intersecting the open end, and a tiltable nozzle section working in the slot and provided with an arm extending across the inlet branch of the nozzle. There are guide members upon the inlet branch

at opposite sides of the arm and they are provided with longitudinal openings and a tapered slide working in the openings in engagement with the inlet branch of the nozzle and the arm.

BOILER.

Mr. J. Renshaw, Point Marion, Pa., has secured a patent on a boiler. No. 841,571. The boiler has the additional contrivance of a water-jacket head arranged between a bridge wall and the tube head with draft flues circumferentially arranged between the tube head and water jacket, and means to permit of easy access being had to the interior of the casing and shell. There is also a head dividing the water chamber from the smoke box and pipe connections between the combustion chamber and smoke box. The combination gives a large increase in the heating surface of the boiler.

LOCOMOTIVE TRUCK.

An improved locomotive truck has been patented by Mr. W. Dalton, Schenectady, N. Y., and assigned to the

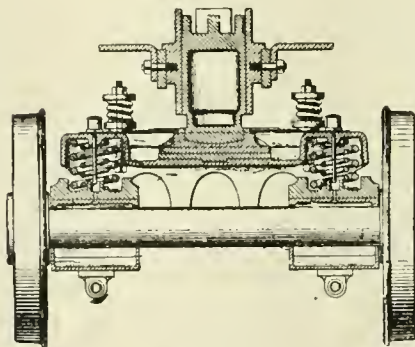

LOCOMOTIVE TRUCK.

American Locomotive Company, No. 841,380. In addition to the main frame, there is a truck frame connected with the capacity of relative lateral movement, and furnished with abutting friction faces connected to the main and truck frames, and means for imparting additional frictional resistance to the lateral movement of the main and truck frames.

PISTON PACKING.

Mr. F. McCarthy, Pottstown, Pa., has invented and patented a piston packing device. No. 842,230. It comprises a combination with a gland having a collar and a shaft extending there-through, of a packing formed of a plurality of segments adapted to be disposed around the shaft in series, the meeting ends of each series of segments being spaced apart and a keeper adapted to surround the segments. The device has the quality of automatically contracting the segments when worn.

THROTTLE VALVE.

A throttle valve has been patented by Mr. M. F. Cox, Richmond, Va. No. 842,448. As shown in the illustration,

the device is a combination of a supply pipe having a concentric steam chamber at one end and an open ended chamber extending therinto, and a double-ended throttle valve located within the chamber and adapted to be moved longitudinally of the end of the pipe and the inner wall of the steam chamber, thereby opening to permit steam to

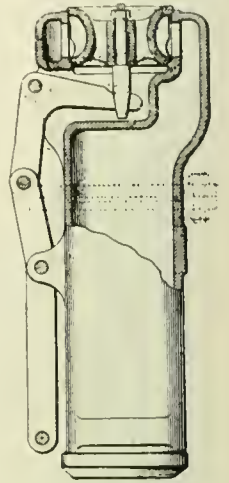

THROTTLE VALVE.

pass into the space formed between the wall and the intermediately-reduced portion of the valve.

TRACTION ENGINE.

A traction engine has been patented by Mr. W. N. Springer, Peoria, Ill. No. 842,840. The engine is furnished with a two-speed transmission gearing interposed between the motor and the traction wheels. There are clutches for connecting the gears, and shifting rods for the clutches for connecting up each set of gears, shifting bars, each adapted to control one of the clutches, and means associated with the bars for moving them in the same direction to cause the disengagement of one clutch and the engagement of the other.

PISTON PACKING.

Mr. J. J. Redner, New York, N. Y., has patented a piston packing device. No. 839,800. It consists of a piece of resilient material in the general form of

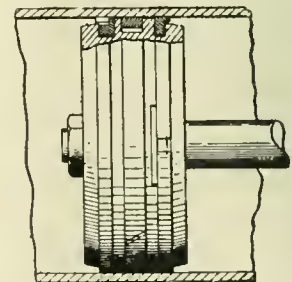

REDNER PISTON PACKING.

an incomplete circle, the two ends nearly meeting, having an offset portion at the sides overlapping both ends and admitting of independent movement of either end, and a stop shoulder or abutment carried at the side of the offset portion, and retaining pins in one of the members and slots in the other

member for receiving the pins to allow of the independent movement of the rings but limiting the extent of their movement.

**German Tank Engines.**

The engines shown in our half-tone illustrations, Figs. 1 and 2 are of a pair of somewhat similar machines built by the Hannoversche Maschinenbau-Aktien-Gesellschaft which being interpreted means the Hanover Locomotive Building Company

The narrow gauge locomotive is represented in Fig. 1. It is a tank engine of about 40 h. p. while Fig. 2 is a standard gauge tank engine of 100 h. p. These engines, although small, are so built that they are comparatively easily examined and are less complicated than the larger engines for regular road service.

The builders inform us that they have supplied a number of these engines for industrial railway service and other purposes, and that the engines have rendered excellent service even under unfavorable conditions. The engines themselves are neat and compact in design and show evidences of that careful finish of parts which is characteristic of continental shops.

The narrow gauge engine has cylinders 7.27 ins. diameter by 11.97 ins. stroke, and the driving wheels are a

face, there is in this little narrow gauge engine 170 sq. ft. packed away in flues and fire box. The grate area is 5.11 sq. ft. The amount of water carried is

ft. The water carried is about 850 U. S. gallons and the coal something over 1,000 lbs.

The steam and exhaust pipes in the

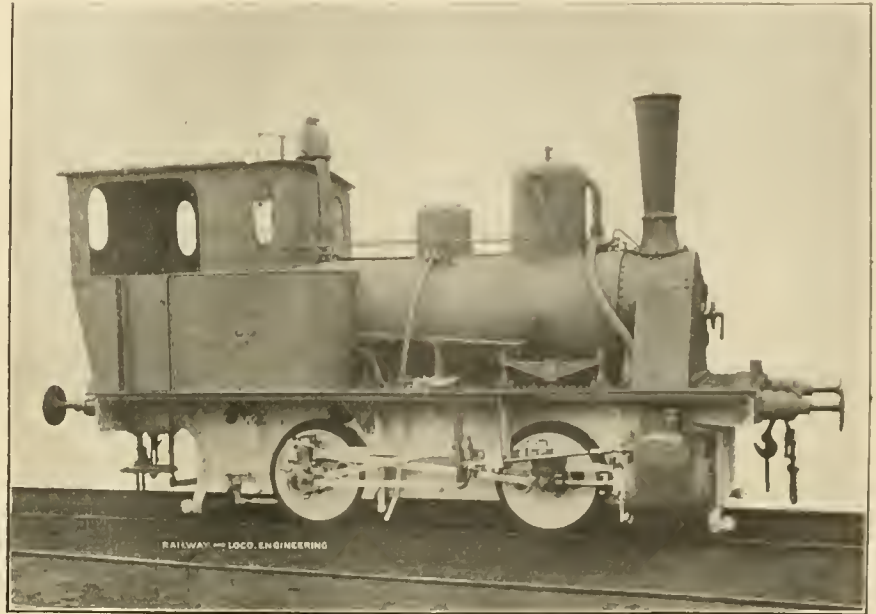

FIG. 2. STANDARD GAUGE TANK LOCOMOTIVE.

something over 200 U. S. gallons. The coal carried is about 650 lbs.

The standard gauge engine Fig. 2, has cylinders 11.22 ins. by 17.32 ins. with driving wheels about 35 ins. in

narrow gauge engine are exposed and the throttle lever in both of them is outside the dome. The Stephenson link motion is used on both engines and it is outside and easy to get at. The whistle shield on the one and the popvalve muffler on the other are interesting.

**Use for the Camera.**

It is said that one of the recent plans adopted on some of the railways in England is the application of photography to the examination of bridges or tunnels which are thought to be giving way. It is the photographer, and not the engineer who makes this kind of inspection, and it has occasionally been found that what might escape the eye of the engineer is not overlooked by the eye of the camera, and another advantage of the photographic method is that there is a graphic record of how things were at the time the photograph was taken.

His name was not Boss, but the initial was the same. One day a fireman was seen about the engine house chalking B. L. F. upon tanks and other prominent places. The foreman having noted what the man was doing jumped upon him hotly, saying, "it is all right for you to belong to the Brotherhood of Locomotive Firemen, but we don't want it chalked all over the place." You are mistaken, replied the fireman. These letters do not stand for Brotherhood of Locomotive Firemen but for Bosse's Latest Failure.

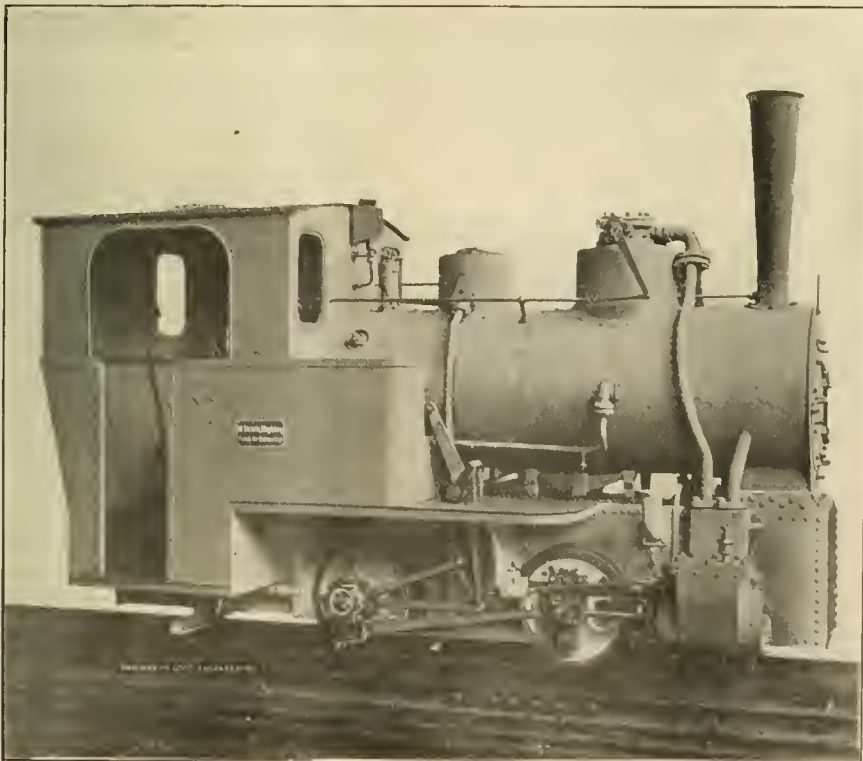

FIG. 1. NARROW GAUGE TANK ENGINE FOR INDUSTRIAL SERVICE.

little over 23½ ins. The wheel base is 43.3 ins. and the pressure of steam is about 175 lbs. The gauge of the road is 23.6 ins. when it comes to heating sur-

diameter. The wheel base is 75¾ ins. and the boiler pressure is close to 175 lbs. The grate area is 11.62 sq. ft., and the total heating surface about 388 sq.

### Water Glass Guard.

The Missouri Pacific have some of their engines supplied with a water gauge glass guard of the style shown in our illustration. It is a brass casting or frame made on three sides and rests on the lower mounting. It is held in place by two long pins which pass through holes in the flanges of the mounting and in the guard itself. These pins have heads on them which prevent them from dropping through, but otherwise the pins are loose and can be dropped in or taken out by hand. The guard has three faces filled with glass  $\frac{3}{16}$  of an inch thick and  $1\frac{1}{16}$  ins. wide. The guard has two horizontal projections for carrying the gauge lamp.

In case anything goes wrong with the water glass itself the frame with its panels of glass prevent the broken bits being thrown about the cab, and even if one or more of the glass panels of the guard become cracked, the fact that they are there prevents steam and hot water from getting in their work on the occupants of the cab. When everything is all right, the three glass panels of the guard allows the water level to be seen from the front and sides. Some roads use a wire netting bent into the form of a cylinder and placed round the gauge glass, but the wire, though it keeps broken fragments from flying out when a gauge glass breaks does not show the water level as clearly as glass. The Missouri Pacific guard has the additional advantage of causing water and steam to blow upward and downward only, and the transparent panels can be taken out and cleaned. Anyway, they are thick enough to stand a fair amount of rough usage. A gauge glass guard which does not in any way obscure the water level and prevents the painful result of an accident is a serviceable affair.

### Civilizing Influence of Roads.

The history of roads is a history of civilization. Good roads are unmistakably a sure index of the various grades of civilization.

Lord Macaulay declares that of all inventions, the alphabet and printing press alone excepted, those inventions which abridge distance have done most for the civilization of our species, and this applies to good roads, even in a greater degree than to the railroad and steamboat.

Every improvement of the means of locomotion benefits mankind morally and intellectually as well as materially. "The road," says Bushnell, "is that physical sign or symbol by which you will best understand any age of people. If they have no roads they are savages, for the road is the creation of man and a type of civilized society. As roads are the symbols of progress, when we trace back the history of the race to the dawn of civilization, we find that the first spon-

sors of art and science, commerce and manufacture, education and government, were the builders and supporters of public highways."

The two most ancient civilizations situated in the valley of the Nile and the Euphrates were connected by a commercial and military highway leading from Babylon to Memphis, along which passed the armies of the great chieftains and military kings of ancient days, and over which were carried the gems, the gold, the spices, the ivories, the textile fabrics and all the curious and unrivalled productions of the luxurious Orient. On the line of this roadway arose Nineveh, Palmyra, Damascus, Tyre, Antioch and other great commercial cities.

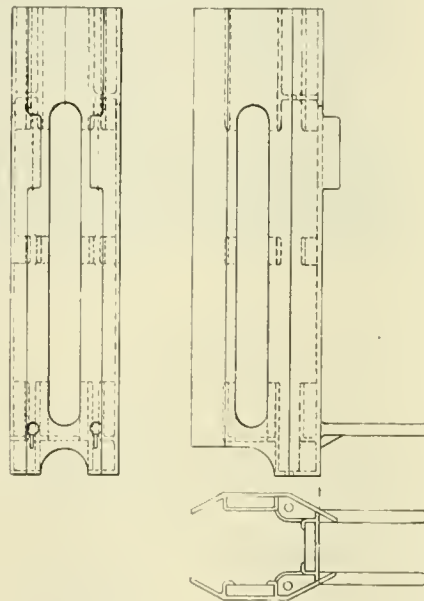

WATER GLASS GUARD ON THE MO. PAC.

On the southern shores of the Mediterranean the Carthaginians built up and consolidated an empire so prominent in military and naval achievements and in the arts and industries of civilized life that for four hundred years it was able to hold its own against the preponderance of Greece and Rome. These Carthaginians were systematic and scientific road makers, from whom the Romans learned the art of road building. The Romans were apt scholars and possessed a wonderful capacity not only to utilize prior inventions, but also to develop them. They were beyond question the most successful and masterful road builders in the ancient world, and the perfection of their highways was one of the most potent causes of their superiority in progress and civilization. When their territory reached from the remote east to the farthest west and a hundred millions of people acknowledged their military and political supremacy, their capital city was in the center of such a network of highways that it was then a common saying: "All roads lead to Rome."

From the forum at Rome a broad and

magnificent highway ran out toward every province of the empire. It was terraced up with sand, gravel and cement and covered with stones and granite and followed in a direct line without regard to the configuration of the country, passing over or under mountains and across streams and lakes on arches of solid masonry.

The military roads were generally sixteen feet wide and sometimes they were double, with an elevated center. Stirrups were not then invented, and mounting stones or blocks were necessary accommodations; hence the lines or roads were studded with mounting blocks and also with milestones. Some of these roads could be traveled to the north and eastward for two thousand miles, and they were kept in such good repair that a traveler thereon by using relays of horses which were kept on the road could easily make a hundred miles a day on horseback.

Far as the eye could see stretched those symbols of her all-conquering and all-attaining influence, which made the most distant provinces a part of her dominions and connected them with her imperial capital by imperial highways.

### Gasolene Locomotive.

A narrow gauge gasolene locomotive is performing good work on an industrial railway in the North of England. The motor is horizontal and is capable of developing 20 brake horse power at 600 revolutions. It has the general appearance of a locomotive, but the casing of the whole resembles the outside of a Belpaire fire-box.

The driving wheels are four in number and are 18 inches diameter and driven from the motor by chain gear. The engine is fitted with a heavy fly wheel which is required for the heavy pulls of rail traction. Two speeds forward and two speeds reverse are provided. The speeds are intended for three and eight miles an hour, but like all motor cars their tendency is to exceed the specified speed. The novel little engine looks like a miniature steam locomotive with a radiator in front of the smoke box.

### Railroad Hash.

The passenger train which went east yesterday morning looked like a dog's breakfast. There were a few Pullmans, a diner or two, then some coaches, baggage, mail cars, then more coaches, diners, mail, and baggage cars mixed up for half a mile, more or less, and an engine on each end of the string. It was the accumulation of railroad hash that had run west during the past twenty-four hours going to The Dalles to get out of the way of other trains coming.—*Hood River (Oregon) News-Letter.*

Activity is the best amen to any prayer.

# General Correspondence.

## Early History of the Lehigh.

Editor:

I read with interest the excerpt from "Development of the Locomotive" in your January issue of the most interesting railway paper published. I particularly noticed two things, the first was the omission of "Hazleton" from the list of shops, and later in the article you spoke of the "Audenried, later the John Campbell, having a valve motion like Clark's." Please correct these points. I am glad that I am able to give you the correct version, as well as a complete history of what is now one of the important divisions of the Lehigh Valley, organized and chartered as the Hazleton Railroad.

My informant was the late Ario Pardee, Sr., who organized the company, later leased it and then sold it to the Lehigh Valley. Another authority is a book written by the son of one of the members of the firm of Eastwick & Harrison, one copy of which is in the library of Swarthmore College. A third was the late David Clark, as well as various engineers of the road before the merger.

The Hazleton Co. was chartered in 1836, built in 1837 and the shops were erected in 1839-40, and the first engine was built there in 1840. It was named the "Lehigh." The company had purchased a locomotive from M. W. Baldwin previously. This was named the "Hazleton," a single pair of drivers and in all respects a Baldwin of that date, except in one important feature, she was a hard coal burner. Mr. Pardee told me that the Hazleton road was the only road that never had a wood burner in service. There was no special arrangement of the boiler. The Lehigh was built on the same plan as the "Hercules" of the Beaver Meadow Railroad, which was the first locomotive to have an equalizer beam. A model of the Hercules was part of the B. & O. exhibit at Chicago in 1892 and Mr. Pardee was the first to see the good points of this device (see Harrison's book).

Mr. Alexander McCausland was the first master mechanic of the Hazleton Railroad until 1840, then a Mr. Merkel, and from 1841 until 1855 Thos. Evans held the position. On September 2, 1855, David Clark was called to the Hazleton Railroad. Mr. Clark found the road equipped with Eastwick and Harrison's four drivers, Hercules type Baldwin single pair, E. L. Miller type and several six and eight driver Baldwins with the well known Baldwin

truck arrangement, also several engines of the road's own build.

Mr. Clark at once caused predictions of dire disaster by building an engine, the "Superior," with six drivers rigidly fixed and no truck. Every mechanic and engineer held that the Superior would never pass a curve. She did, however. The Superior was a six-wheeler, about 14 or 15 x 22 ins., 44-in. drivers, boiler about 42-in., with swallow tail fire box similar to Winans, but with fire door at the rear. She burned anthracite coal and was scrapped in 1885 or 6. The "Oswego," built about the same time, was in service in 1895 at Easton.

Mr. Clark used the same arrangement of rods as Baldwin, that is, main rod to rear driver and all wheels

1882 by David Clark and Thos. G. Blatch (now general manager Hazleton Iron Works Co.), and was first applied to the W. C. Alderson No. 400. This engine was built to run on the Easton and Amboy Division, L. V. R. R., and did make several trips in competition with the famous No. 171, C. R. R. of N. J., and the engine made as good time as was expected of her. The Alderson was withdrawn from this run because the Easton shops tried to improve (?) the design and she finished her career climbing the mountains of Pennsylvania. Clark's valve motion was applied to the Wm. Brockie, No. 440 (same as the Campbell, see August issue, 1906), and the "Jupiter," No. 120, a ten-wheeler.

Clark built the first Wootten for the



LOS ANGELES LIMITED, A. T. & S. F. THESE ENGINES BURN FUEL OIL.

coupled. Encouraged by the success of the Superior, he built engines with eight drivers, rigid base, and in 1867 built engines with 20 x 26-in. cylinders, something rather strenuous in those days.

The Hazleton road was merged with the Lehigh Valley on June 2, 1868, and Mr. Clark then leased the shops until 1871 or 1872, when the Lehigh again took the shops with Mr. Clark as master mechanic until his retirement in 1892.

The device on the Audenried, No. 471 (changed to John Campbell because Mr. Campbell had renamed the "Delano," No. 66, the "David Clark") was not only like Clark's, but was Clark's. This device was patented in

Lehigh Valley, the Jno. R. Fanshawe, No. 357, which for some reason was rebuilt with firebox on top of frames. This engine for years pulled the fast passenger trains over the Wyoming Division and was one of the main reasons why the Duplex, No. 444, was built—that is "Wilkes-Barre" tried to get something to beat "Hazleton." The Fanshawe was the first of the "Campbell" type; many others were afterward built.

At the time of Mr. Clark's retirement the Lehigh had 639 engines in service. Of this number 450 were built at their own shops (six in number), and of these 130 were Clark's. The eight-wheelers were pulling the fastest passenger trains; the ten-wheelers the

fast freights on all divisions, so that you omitted a shop that built 30 per cent. of their engines, while 16 per cent. was the expected quota.

I have some extended information regarding the engines of the Lehigh up to 1892 and will be pleased to furnish you any points you may request should you desire me to do so.

A. S. LITTLETON.

Cleveland, Ohio.

#### Slipping of Drivers.

Editor:

In the December number of RAILWAY AND LOCOMOTIVE ENGINEERING, Mr. W. M. De Witt and "Technology" call me to account for certain statements that I made in the October number of your magazine. Before going further, I wish to state that I understood from the article written by "Technology" that an increase in the diameter of drivers was a practical remedy for driver slip.

I understand perfectly well that the force applied at the crank pin must be greater, in order to produce either rotation or slipping, when the diameter of the driver is increased. It certainly is more difficult to slip a driver, with the same crank length and cylinder power, after its diameter has been increased; but this matter has nothing to do with the practical solution of the problem. As far as literal accuracy is concerned, I have to agree with "Technology." The large driver does resist slipping, and also resists rotation, in a greater degree, than the small driver, it being assumed, of course, that all other conditions remain unchanged.

I frankly acknowledge that the slipping can be eliminated by increasing the throttle, and in either case the tractive power of the locomotive suffers reduction.

I am much pleased that the treatment of the subject has produced so much discussion, for undoubtedly many engineers who are annoyed by the evil of driving wheel slip, thought as I did, that the statement, "that large drivers have a greater resistance to slipping than small drivers" afforded a solution of the problem. The statement made by "Technology," while it is perfectly accurate, is devoid of interest in a practical way, as it is the object of both the locomotive designer and engineer to eliminate this evil without reducing the tractive power of the locomotive, and any method of reducing driver slip that has as an accompaniment decreased tractive effort can never appeal to the judgment of the engineer who is stalled on a heavy grade and has just discovered that his sand box is empty.

T. H. REARDON.

North Adams, Mass.

#### Iron Wedge and Table Lock.

Editor:

I am sending you a couple of sketches of a couple of shop kinks which may be interesting to readers of *Railway and Locomotive Engineering*. The first represents an iron wedge to use in blocking engines, etc., see Fig. 1. In order to fully appreciate the use of an iron wedge it is necessary for one to thoroughly familiarize one's self with its advantages by using it. In blocking up an engine or putting in a spring where the time is limited, it is a time saver. The use of wedges in this capacity is a subject that all engineers ought to be familiar with, but

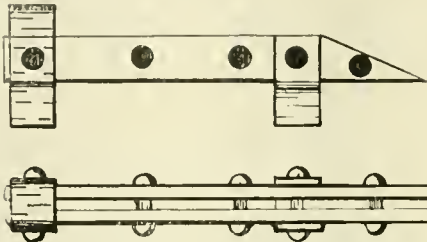

FIG. 1. IRON WEDGE FOR BLOCKING UP DRIVING WHEEL.

cases come up almost every day where had the engine-man been thoroughly familiar with the use of the wedge a complete engine failure would have been avoided.

The next sketch, Fig. 2, is of a lock that can be used on a drop pit or on a turn-table. It is used on the turn-table to hold the table in place in moving the engine off or on the table, to prevent the table from shifting and allowing the engine to get on the ground. Sometimes with a low pilot in placing an engine on the table the table will be knocked to one side, but when fastened

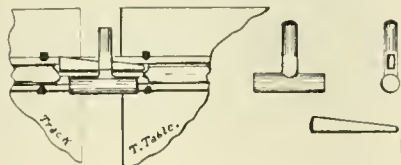

FIG. 2. TURN-TABLE OR DROP PIT LOCK.

by such a lock, an occurrence of this kind is avoided. When used on a drop pit or any pit where it would be necessary to take up the rail it is very handy.

JOHN F. LONG.

Beaumont, Kan.

#### Why Engines Slip.

Editor:

I have read many different theories as to the cause of engines slipping when the engine is at bottom forward eighth (that is the leading pin). Some writers have placed the cause to the counter balances lifting the weight off of the rails at this point of stroke. I cannot agree with this idea at all, as

the slipping occurs when engine is running at slow speed and counterbalances have no tendency to lift the weight from the rail at this speed; if we note closely the angular positions of the rods on either side of the engine it can plainly be seen that with the leading pin on the bottom forward eighth and the following pin on the top forward eighth, there is more weight on the main drivers at this point than at any other point of the stroke—that is, when the engine is working steam in forward motion, as the leading pin is pushed downward and the following pin is pulled downward by the angle of the rods, thus transmitting weight from the front of the engine to the main drivers.

Following is my theory of the engine slipping as above mentioned. When the leading pin is at bottom forward eighth, the forward port is full open (that is, with bar in full gear forward) and the piston has got practically boiler pressure against it, while the other pin is on the top forward eighth and the port just in the act of closing, but the back end of the cylinder practically with boiler pressure against the piston. When the engine is in this position I consider that it has more power than at any other point of the entire revolution for the following reason: that crossheads are traveling faster on either side than the pins are, on account of the angular motion of the main rods, as it is known that the crosshead travels farther over the guide from the forward center to the bottom quarter and from the top quarter to the forward center, thus giving the engines more advantage over the pins at the above named points than at any other point of the revolution.

When the engine is working at full capacity and the adhesion to the rail cannot withstand any greater resistance, the results are that when the engine gets in the above position the adhesion can stand no further resistance against slipping; the results are that the engine will start to slip, and just as soon as the engine slips far enough to let the following pin come close enough to the center to exhaust, that side of the engine has ceased to assist the leading pin, and the leading pin not being able to continue, the slipping wheel again will catch the rail and hold until the next revolution, when it will again repeat the slip as above stated, which consists of about ten or twelve inches on the tire. I have noticed engines slipping as above mentioned, that is, when working engine slow with long cut-off. I would like to hear from some of the readers of LOCOMOTIVE ENGINEERING in regard to this subject. I am open to conviction.

W. D. RINEHART.

Brunswick, Md.



### Position of Headlights.

Editor:

On page 59 of the February number of RAILWAY AND LOCOMOTIVE ENGINEERING there is a letter to the Editor signed "Reader," regarding the lowering of headlights on large locomotives. The writer states that he understands "the L. S. & M. Ry. have tried and abandoned the scheme on their large engines." By the L. S. & M. Ry. I suppose the Lake Shore & Michigan Southern Railway is meant, as I do not, at present, recall another road bearing those initials. If so, your correspondent has been misinformed as that company has not discontinued the practice of lowering the headlights on its engines, and has no intention of so doing.

In the experience of the Lake Shore road there has been only one possible objection to having the headlight so located. The transparent number, in the side of the headlight, is not visible from a point beside the track when the front end of the locomotive has passed a very short distance beyond that point, on account of its being hidden by the smoke box.

Owing to the increasing height of the Lake Shore engines, it became necessary to cut down everything above the top line of the boiler in order to keep within the clearance limits. This necessitated the lowering of the headlight, and it was placed at about the centre of the smoke box door, that being the location at which it was thought it would accomplish the best results. A better light is thrown just where it is needed the most, and the lamp is easily reached and taken care of. If an engine, such as those in common use ten or twelve years ago, with the headlight mounted on top of the smoke box, were placed along side of one of the large modern locomotives having the headlight at the centre of the smoke box door, the two headlights would be seen to be on about the same level, that on the smaller engine being possibly a trifle lower than the other; so that lowering them on the large engines is merely bringing them down to where we have always been accustomed to have them.

A headlight placed on top of the smoke box, close to a short stack, is the source of considerable annoyance, the wind, combined with the sharp exhaust from the stack, frequently extinguishing the light. The lowering of the headlight has largely disposed of this difficulty. The headlight bracket, on the Lake Shore engines, is bolted to the smoke box door, and when the door is opened the headlight simply swings with it, causing no inconvenience whatever. C. D. WRIGHT.

East Cleveland, O.

### First Scottish 4-4-2.

Editor:

By same post, I am sending you a photograph of one of the fourteen express locomotives delivered to the North British Railway by the North British Locomotive Co., and built by them at their Hydepark works, Glasgow. These engines, which are the first passenger locomotives designed by Mr. Reid, the present superintendent, are noteworthy as being the first "Atlantics" built for a Scottish railway, and with the exception of a few small slunting "pugs," the first outside cylinder engines built for the North British Railway for over 40 years.

As will be seen by the photograph, they approach very closely to the maximum permitted by the British loading gauge, and perform the express passenger services on the Main Line, for which they are designed, with ease and economy.

The principal dimensions are: Cylin-

### Heroism of the Engineer.

Editor:

In the February issue of RAILWAY AND LOCOMOTIVE ENGINEERING there appears an article by Mr. Westerfield, in which he contends that the daily and technical press of the country are inclined to disparage the achievements of the Locomotive Engineer.

It would appear to a disinterested observer that the daily press is inclined to enlarge upon the engineer's accomplishments oftener than it is to criticise his actions.

We frequently note in the accounts of a head-on collision or accident due to an open draw bridge, how the engineer bravely stuck to his post and went down with his train, a dead hero, when anyone familiar with the modern locomotive knows that after having applied the brake, closed the throttle, and opened the sanders, the engineer is powerless.

Engineers have been known to reverse their engines and attempt to start the



NORTH BRITISH 4-4-2 WITH BELPAIRE BOILER.

ders (simple) 20" x 28"; driving wheels, 6' 0"; bogie wheels, 3' 6"; trailing wheels, 4' 3"; boiler, steel, with inner firebox of copper. It contains 257 tubes, 2 ins. diameter, steel. The heating surface is: Tubes, 2,071.4; firebox, 184.8; total, 2,256.2. Pressure, 200 lbs. per sq. inch. Weight on bogie, 15 tons 18 cwt.; on coupled wheels, 40 tons; trailing, 18 tons 10 cwt.; total, 74 tons 8 cwt. (all 2,240 lbs. per ton). Tender carries 7 tons of coal and 4,240 Imperial gallons of water. The piston valves are of the Smith pattern, with collapsible segmental rings. The engines are equipped with the Westinghouse brake, and vacuum ejectors, so that trains fitted with either brake can be worked.

S. A. FORBES.

Isla, Perth, Scotland.

He who sedulously attends, pointedly asks, calmly speaks and coolly answers, and ceases when he has no more to say, is in possession of some of the best requisites of man.—Lavater.

wheels revolving backwards with driver brake applied, but it is not necessary to go into the details of a comparison of static with kinetic friction to prove that a braked revolving wheel has more retarding energy than a locked or sliding wheel. I have been demonstrated time and again that even a poor driver brake is more efficient than a sliding wheel.

Therefore, if the man at the throttle has done all in his power to stop the train, which requires but three or four seconds time, he is at liberty to leave the engine, and if he deliberately stays at his "post" and crashes into another train or through a bridge, he does nothing more or less than commit suicide.

There are, of course, some exceptions such as on a runaway freight train, where a man may sacrifice his life in an attempt to save the company's property, but a great many people are of the opinion that "discretion is the better part of valor," and that a live coward is worth more to the community than a dead hero; the live coward can at least continue to support

his family. A great number of the traveling public are also of the opinion that if some engineers paid more attention to train orders, red and green signals, and less to the heroic part of their occupation, there would be a greater element of safety in modern railway travel and a reduction in the number of accidents.

G. W. KIEHM,

Washington, D. C.

### Air Bell Ringer.

Editor:

I enclose rough sketch of Simple X Bellringer and the description of same: I have made the explanation as short as I consistently can. Any one can make this ringer as there is no patent on it. I figured it out myself, and don't know of any like it.

Air enters at Q, passes by valve V, and pushes rubber washer exhaust valve R against piston P, moving same upward. Meanwhile admission valve V closes and air is used expansively until exhaust valve strikes the nuts marked E, the piston traveling onward opens the exhaust port to hollow piston rod and the pressure is discharged through hollow rod, ports X and through ports G in the body.

On down stroke piston strikes the exhaust valve and carries it down. It strikes the nuts O and opens admission valve and the operation is repeated.

By removing cap-nut B, admission and exhaust valves may be taken out and adjusted to suit the weight of bell to be operated. The spring is used to assist valve V in closing.

Any suitable device may be attached to piston rod to operate the bell.

The name Simple X is given it because it is easily taken care of.

It is extremely simple and easy to regulate and I am sure any one using it will find it cheap as it uses less air than any ringer now in use that I know of. I hope you will find room for drawing and description in your March number, that it may benefit any of your readers who desire to use it. Thanking you for past kindness with good wishes, I am.

JNO W. GRAYBILL.

Bridgeport, Ohio.

### Adjusting Stephenson Valve Gear.

BY JAMES KENNEDY.

Among the subjects of perennial interest to railway men, valve-setting occupies a conspicuous place. The importance of correctly adjusting and maintaining the position of the valves cannot be overestimated. Like the valves in the hearts of animals their perfect operation is the very life of the moving force of the machine. The work of adjusting the mechanism has been absurdly overestimated, and the idea assumed by

many that the operation is a difficult one is a gross error. Like other alleged mysteries that owe their importance to the lack of opportunity of witnessing their true inwardness, familiarity soon begets a spirit of common regard. There is just the same degree of accuracy necessary in adjusting the attachments of the throttle valve. Both are a simple matter of careful experiment and exact measurement. In adjusting the ordinary sliding valve it may be said at the outset that there are degrees of proficiency required from the designing of the parts of the gearing to the simple matter of squaring the eccentric rods in a brief roundhouse examination. The working machinist is very safe to assume that the designer's part is correct and he can safely proceed with the adjustment of the valve gear, which is generally among the last operations in the building or repairing of a locomotive.

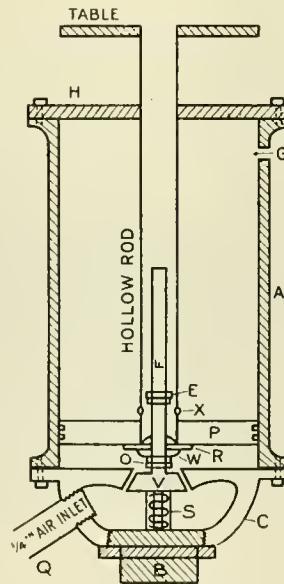

SIMPLE X BELL RINGER.

Assuming that the four eccentrics are loose upon the driving axle of an ordinary 8-wheel locomotive, the best plan is to move the engine until one of the crank pins on the axle to which the eccentrics are attached is on the forward centre, that is the point nearest to the cylinder. We will assume this is on the right side. If the eccentric which is designed to move the engine in a forward direction is intended to be next the frame, the eccentric may be promptly put in place somewhere about 85 degrees above the line of the crank pin, the exact position need not be ascertained at this time, the eccentric being temporarily held in place by one or more set screws. The eccentric intended for the backward motion is placed a similar distance below the crank pin or centre line of the axle. The eccentrics on the other side of the engine can be similarly attached temporarily in their places. Assuming that

the links have been already attached to the rockers and the link hangers adjusted to the arms of the lifting shaft, the forward eccentric rod should then be adjusted to the top of the link and the back eccentric rod to the bottom of the link. We are now ready to begin the operation of correctly adjusting the entire gearing, and it may be stated that inasmuch as the preparatory markings of centers and openings are of prime importance, it is proper that the locomotive should be levelled. It does not follow that because the engine is new or newly repaired it is exactly level. The tendency is to drop slightly in front, which is generally rectified when the water is placed in the boiler. When the engine is level the rocker should be placed exactly plumb. This can readily be done by moving the reverse lever while a fine line is hung over the rocker end with two small weights attached and the lever stopped at the exact point where the two lines are equidistant from the center of the rocker. The valve rod should then be adjusted so that the valve is exactly in the middle of the valve seat. A neglect of this important point will cause variations in the valve travel that can never be entirely overcome. At this time it should be noted whether the valve yoke is properly adjusted to suit the thickness of the valve, as in the case of an engine being frequently repaired the valves and valve faces wear rapidly and a liner may be necessary under the valve yoke to prevent undue strain upon the valve rod packing as well as a tendency to tilt the valve.

Before finally attaching the valve rod to the rocker, the best method of marking the exact position of the valve openings is by a tram reaching from the guide yoke or other fixed part of the engine to a suitable position on the valve rod. Both ends of the tram are sharpened, one end to adjust itself to a center punch mark on the guide yoke, and the other end, which is bent so as to scratch a mark readily on the valve rod. The points marked are necessarily where the valve is beginning to open at the front and back steam ports. The marks on the valve rod should be marked lightly with a fine center punch. The steam chest lid can then be put on the steam chest and any danger of material or articles falling into the steam chest can be entirely avoided.

The next operation should be the ascertaining of the exact dead centers or positions when the crosshead and piston are standing still at each end of the piston stroke. This point should be located very carefully. If the rim of the main driving wheel is near the guide yoke the same tram may suit to locate the center, but generally a longer tram is necessary with both ends bent. The engine may then be moved to a point where the crosshead is about half an inch from the back

or forward end of the stroke. A fine center punch mark may be made on the crosshead and guide yoke or guide block as the case may be, and a pair of compasses carefully adjusted to the two points. Accompanying this adjustment, the tram should be extended from the guide yoke or other point to the rim of the wheel and an arc drawn by the sharp end of the tram. The engine should then be moved over the center until the crosshead returns to the exact point where the compasses touch the center marks on the crosshead and guide yoke or block.

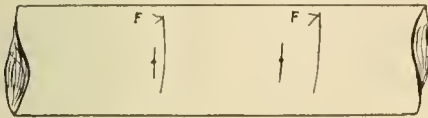

FIG. 1. FIRST MARKING.

Another arc or line should be drawn on the wheel rim and a point between those two arc lines is the dead center. It will be noted by those who have time to try the experiment that it is difficult to obtain this center mark in a positively correct position. A repetition of the experiment with the crosshead at a greater or less distance from the end of the stroke will show a slight variation. This arises from the fact that while the crosshead is moving very slowly near this point the rim of the wheel is moving rapidly, and it may be added that the valve is also moving rapidly at this time. Hence the utmost care should be taken in ascertaining the dead centers. It is often noted that in looking over the valves, it may be only a few days after the engine has been running, that the exact center, as newly discovered, may show a considerable variation in the rim of the wheel. This arises from the lost motion already caused by the incidental wear of the engine bearings, so that old markings on wheel rims instead of being of any value are often misleading. Variations in the dead center marks will also show in marking while the engine is moving forward as compared with markings that are made while the engine is running backward.

It is seldom that the wheel rim variations in marking are heeded, but they are of real value if a serious effort is maintained to keep the valves in correct positions.

Having the valve rods marked and the dead center points located, we now proceed to ascertain the position of the valves. As one at a time is good work, at least for a beginner, we may as well proceed with the right forward. Place the reverse lever in the extreme forward notch and move the engine forward until the tram touches the dead center point. Then proceed to make a mark on the valve rod. If you are on the forward center observe if the mark made on the

valve rod is near the forward opening mark. Keep in your mind's eye the location of the end of the piston stroke and steam port you are working on. Move the engine ahead till you reach the other end of the stroke where it is assumed marks have been made on the wheel rim in the same manner as before. With the tram at the center try the tram on the valve rod and make another scratch. It is not to be expected that the scratches will be equidistant from the marks showing the valve openings. We will suppose that Fig. 1, is about the location of the scratchings and opening marks.

It will be seen at a glance that the valve opening at the front end of the stroke is about three-eighths of an inch, while at the back end there is about one-eighth of an inch of lap, or in other words there is no opening at the back end of the stroke until the valve rod has moved at least one-eighth forward. It will readily be seen that no matter which end of the stroke we are at the valve rod must be moved about a quarter of an inch ahead in order to equalize the opening at both ends of the stroke. Assuming that both ends of the rocker are of equal length, the right forward eccentric rod must be shortened a quarter of an inch. It is not

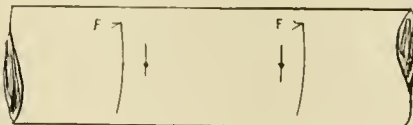

FIG. 2. ECCENTRIC ROD ADJUSTED.

necessary at this time to make the alteration perfectly exact, but we shall suppose that the rod is moved and that the opening on each end is about a quarter of an inch. Another trial of the tram at both ends should show something resembling Fig. 2.

We will assume that the amount of opening desired at the end of the stroke is one-eighth of an inch. It will be seen that presuming we are at the front end opening the valve rod must be moved ahead one-eighth, but it must be evident that while moving the eccentric rod would accommodate us at this end of the valve stroke, it would have the effect of increasing the opening at the other end, as was seen in the previous experiment, it is, therefore, necessary when the eccentric rod has been evenly adjusted that the eccentric itself should be moved in order to increase or diminish the amount of opening at both ends of the valve stroke. In the present instance the eccentric must be moved further away from the crank and approach more nearly to right angles or 90 degrees from the crank. While the eccentric is being moved, the valve rod should be carefully watched and the eccentric secured at the desired point, which after experimentally moving the

engine and marking the dead center will show something like Fig. 3.

Turning our attention to the backward movement of the engine, it is necessary to place the reversing lever in the notch furthest back and proceed with our experiments as before. Very likely the discrepancies will be greater than what is shown in Fig. 1, but the same methods will bring the desired results, and it will be noted that after having made the necessary changes on the backward eccentric rod and eccentric, the effect of the changes, in addition to bringing the openings of the valve to the desired amount, will have had the added effect of slightly changing the amount of openings on the forward motion. This is easily explained by the fact that in changing the position of the eccentric or the length of the eccentric rod the position of the link is slightly changed, thereby affecting the exact distribution of the motion in a ratio to the amount of change made. There are other disturbing causes that must not be overlooked. The length of the reach rod is an important factor, and while the experiments are going on in regard to adjusting the eccentrics and rods, it is well to observe the amount of clearance that the link block has at each end of the link. It is safe to allow at least a quarter of an inch more clearance at the top of the link than at the bottom. In links where the amount of clearance is limited it is perfectly safe that the link block may approach within one-eighth of an inch when the link block is at the bottom of the link, as the tendency of the link is always to drop lower down as the joints begin to wear and as the heat expands the length of the reach rod without materially expanding the length of the frames.

Another important consideration is the fact that while the valves may be carefully adjusted to open correctly at the extreme length of the travel of the valve, it does not follow that when the lever is hooked up nearer the center of the quadrant that the openings retain their exact ratio to each other. The tendency

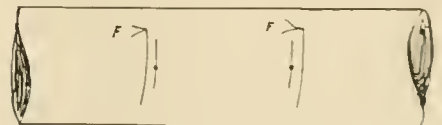

FIG. 3. ECCENTRIC ADJUSTED.

is in addition to increasing the amount of opening or lead as it is called, to create variations in the amount of opening at each end of the valve stroke. In engines that are used with short valve travel, as in light running engines, it is often necessary to sacrifice the exact adjustment at the extreme end of the stroke in order that the valve openings may be squared at the point where the engine is called upon to perform most of its work. It need

hardly be stated that the same remarks in detail apply to the left side of the engine, and that in common practice both sides are being adjusted while the engine is being moved or while the wheels are being revolved.

It has already been noted that an examination of the exact position of the valves after the engine has been running a short time will show more or less variation corresponding in a great degree to the quality of the general workmanship exhibited in the construction or repair of the engine. Repeated examinations and readjustments are invariably necessary. The number and variety of joints through which the motion has to come before reaching the slide valve, renders the retention of the exact position of the valve for any length of time a physical impossibility.

#### Steel Gondola Dump Car.

Our illustration shows what is probably the first all steel car to be made in Canada. It is composed of structural steel shapes and plates and has been built for the Canadian Pacific Railway

this gives a box with contents about 1,532 cubic feet. The distance between the truck centres is 25 ft. 8 ins. The wheel base of the truck is 5 ft. 6 ins. There are twelve doors in the floor and these can be operated three at a time. The doors are 54 ins. wide by about 72 ins. long, all except the doors at each corner of the car, which are made somewhat shorter, so that the narrow platform over the end sills with which these cars are provided may be included in the length of 38 ft. 3½ ins. over end sills.

The dump mechanism is ingenious. A shaft passing along the outside of the box girder centre sill has fastened to it a pair of cranks for each door and from the cranks a connecting rod is fastened to the end of a section of 2½ in. pipe, which is pushed up or down inside a pair of hangers, which make the pipe move as if on an inclined plane. When the doors are shut they rest on the pipes by means of small, flat iron bar stirrups, the ends of which are easily discernible in the illustration. The doors can be opened to about 26 ins., the space over

ion as regards the latter day wonders, seven of which are:

The Brooklyn bridge, the underground railroad, including tunnels to Jersey City and Brooklyn, the Washington monument, the capitol at Washington, with its dome weighing 8,000,000 pounds; the modern steel skyscraper, the Echo mountain search light, of 375,000,000 candle power, and the United States Steel Corporation. We are speaking of things made by man; of those wonders given to us by God the seven are: Niagara falls, the Mammoth cave, Old Faithful, the tireless geyser in Yellowstone park, the big trees (Sequoia) of California, the Grand canyon of the Colorado the great fresh water lakes, and the Great Salt Lake.—*New York Press.*

Among modern things made by man the locomotive engine appears to us to be entitled to a place.

#### First Mountain Railway.

Automobilists who have enjoyed a tour through the Austrian valleys that lead from Vienna to the Tyrol enjoy the privilege of seeing what was once considered one of the railway wonders of the world. It was the first railway to cross a high mountain and rivals engineering achievements hardly surpassed on the Union Pacific.

It is on the railway from Vienna to Venice, passing over several ranges of the Alps, and particularly the Semmering pass, over a mountain railroad constructed between the years 1848 and 1854, or within 15 or 20 years of the introduction of the railway into civilization, and 20 years before America's first transcontinental railway. Thirty-five miles over that pass, the Semmering, southwest of Vienna, was constructed during these years, having in its length 15 tunnels and 16 viaducts, with a maximum grade of 2½ per cent. The cost of the 35 miles was \$300,000 per mile. It was built, as was the entire line from Vienna to Venice, 600 or more miles, owned and operated by the Austrian government, since at that time Venice and that portion of Italy was under the dominion of the Austrian and Italian governments jointly.

Contracts have been let by the National-Acme Manufacturing Company of Cleveland, Ohio, for the erection of an addition to their present plant; the new building will be of brick and steel construction, approximately 400 feet long and six stories high. It is hoped to have it ready for occupancy July 1st of this year. This concern, it will be remembered, make screw machines, set screws, cap screws, machine screws and special milled work turned from steel, iron, zinc and brass.

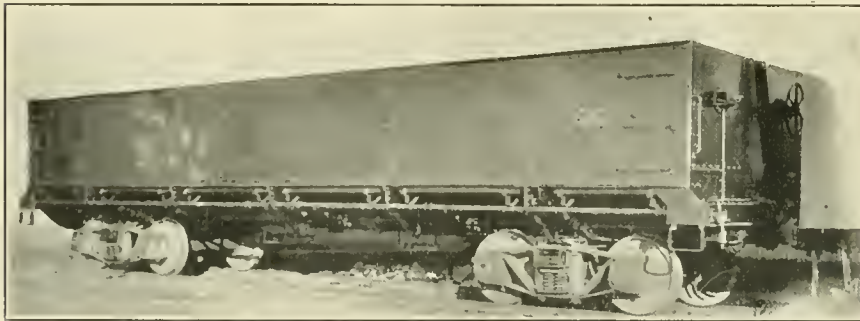

FIRST STEEL DUMP GONDOLA MADE IN CANADA.

by the Dominion Dump Car Co., Ltd. The capacity of the car is 100,000 lbs.

The center sills are of the ordinary box girder type, and the side sills are practically the side plates of the car, which are braced to the floor by ¼-in. plates cut at an angle and secured to the car sides between angle irons and riveted at the bottom to the cross frames between the dump doors. These beveled upright plates standing at right angles to the car sides, take the place of the old stake and stake pocket idea which was the accepted method of holding the sides of gondolas. The form of construction here adopted is very stiff and, the side braces are entirely out of the way, being on the inside of the car over the crossbeams. Incidentally this gives the car a smooth outer surface and where floor and side join an angle iron the full length of the car prevents the side from being scraped.

The length of the car inside is 36 ft. 9½ ins., and the width is 9 ft. 7 ins. The height of the coal sides is 54 ins., and

the centre sills has to be cleaned off by shovel in case fine material is dumped, but the large opening along the sides makes the car for all ordinary purposes practically a self cleaner. The car is well built and it makes a good appearance.

#### New Seven Wonders.

The seven wonders of antiquity were: The pyramids, Babylon's gardens, Mausolu's tomb, the Temple of Diana, the Colossus of Rhodes, Jupiter's statue by Phidias, and the pharos of Alexandria, or, as some prefer, the palace of Cyrus.

The seven wonders of the middle ages were: The coliseum of Rome, the catacombs of Alexandria, the great wall of China, Stonehenge, in England, the leaning tower of Pisa, the porcelain tower of Nankin, and the mosque of St. Sophia at Constantinople.

How do these compare with the seven wonders of the modern world? Perhaps there may be a difference of opin-

**Tank Engine for the Nevada Northern.**

The American Locomotive Company have recently built a heavy tank engine for the Nevada Northern Railway. This engine is intended for service between the mines of the Nevada Consolidated Copper Company and their smelting plant, and is of the 2-8-2 type, with a total weight in working order, with tank and coal bunker one-half full, of 225,000 lbs., of which 172,000 lbs. rest on the driving wheels. The cylinders are simple, being 19 x 26 ins., and the driving wheels are 48 ins. in diameter. The calculated tractive power is 33,240 lbs. The total weight of the engine is 225,000 lbs. and with the weight on the drivers as stated, the ratio of tractive power to adhesive weight is as 1 to 5.1.

Both front and rear trucks are of the

wheels, and this gives a height from the center of the cylinders to the top of the saddle of 52½ ins. The tanks are placed as low as possible, consistent with proper clearance of the driving wheels, so that although the center of gravity of the boiler is higher than usual, the center of gravity of the whole engine is lower on account of the position and weight of the water in the tanks. Thus a good space between the boiler and machinery is provided which will facilitate inspection and repairs without unduly raising the center of gravity of the engine.

The boiler of this engine is 66⅞ ins. in diameter at the front end and the working pressure is 200 lbs. per sq. in. The heating surface is in all 2,643.6 sq. ft., made up of 166 in the fire box and 2,477.6 in the tubes, of which there are 304,

possible between the backhead of the boiler and the coal box. For this purpose the front side of the coal box is sloped downward towards the rear. This adds about 2½ ft. to the space between the coal box and the backhead, which facilitates the operation of firing the engine.

Some of the principal ratios of the design are as follows:

Weight on drivers	= 5.18
Tractive effort	
Total weight	= 6.77
Tractive effort	
Tractive effort x diameter of drivers	= 605
Heating surface	
Total heating surface	= 57.5
Grate area	
Total firebox heating surface	= .063
Total heating surface	
Weight on drivers	= 65
Total heating surface	



SUBURBAN TANK ENGINE FOR THE NEVADA NORTHERN.

E. C. Morrow, Master Mechanic.

American Locomotive Co., Builders.

radial inside bearing type, and in order to equalize the front truck and the two forward pairs of driving wheels a style of construction, in the spring arrangement on the front truck, was necessary, which differs from that ordinarily used on this type of truck. The forward equalizer beam rests on a cross-spring, the ends of which rest on bearings which are capable of a vertical movement with respect to the frame. These bearings are guided by hollow, rectangular castings which enclose the bearings and are attached to the frame. The bearings rest on the top of the continuous axle box, plates being interposed between the bearing and the box to act as wearing surfaces. This arrangement provides for the lateral movement of the truck.

This engine is built so that the height of the center of the boiler from the rail is considerably greater than is usual with the same diameter of boiler and driving

each of 2 in. diameter and 15 ft. 8 ins. long. The grate area is 46 ft., thus giving a ratio of grate to heating surface as 1 is to 57.

In order to provide as much water-holding space as possible the inside tank sheet follows the curved line of the boiler; it was necessary, therefore, in this design to pass the reach rod through the water space, which is unusual even in this type of engine. A pipe acts as a conduit for the reach rod and has a flange connection with the rear sheet of the tank and a flange connection at the front end, with a casting bolted to the bottom of the tank. This casting is open at the bottom and the arm of the reversing shaft passes through this opening, which is made sufficiently large to permit of the free operation of the arm.

In the design of this engine care has been taken to provide as much space as

Total weight	= 85
Total heating surface	
Volume of 2 cylinders	= 8.52
Total heating surface	= 311
Cylinder volume	
Grate area	= 5.4
Cylinder volume	

Some of the dimensions of the engine are as follows:

- Wheel Base—Driving, 15 ft. 0 in.; total, 34 ft.
- Axles—Driving journals, 8½ x 12 ins; engine and trailing truck journals, diameter, 7 ins., length, 14 ins.
- Firebox—Type wide; length, 107⅞ ins.; width, 62¼ ins.; thickness of crown, ⅜ in.; tube, ½ in.; sides, ⅜ in.; back, ⅜ in.; water space, front, 4 ins.; sides, 3½ ins.; back, 3½ ins.
- Crown Staying—Radial 1 in.
- Air Pump—11 in.; 4 reservoir, 16 x 74 ins.
- Tank—Capacity, 2,500 gallons; capacity fuel, 5 tons.
- Valves—Type, slide; travel 5⅞ ins.; steam lap, ⅜ in.; lap, 0 in.
- Setting—In full gear, line and line.
- Wheels—Engine truck, diameter 42 ins.; trailing truck, diameter 42 ins.

# Railway and Locomotive Engineering

A Practical Journal of Railway Motive Power and Rolling Stock.

Published Monthly by

**ANGUS SINCLAIR CO.**

136 Liberty Street, New York.

Telephone, 984 Cortlandt.

Cable Address, "Loceng," N. Y.

Glasgow, "Locauto."

**Business Department:**

ANGUS SINCLAIR, President.  
JAMES KENNEDY, Vice-President.  
JAMES R. PATERSON, Sec'y and Treas.

**Editorial Department:**

ANGUS SINCLAIR, Editor.  
GEO. S. HODGINS,  
JAMES KENNEDY, } Associate Editors.  
J. P. KELLY, }

**Advertising Department:**

Eastern Representative, S. I. CARPENTER, 170  
Summer St., Boston, Mass.

**British Representative:**

THE LOCOMOTIVE PUBLISHING CO., Ltd.,  
Amen Corner, Paternoster Row, London, E. C.

**Glasgow Representative:**

A. F. SINCLAIR, 15 Manor Road, Bellahouston,  
Glasgow.

**SUBSCRIPTION PRICE.**

\$2.00 per year, \$1.00 for six months, postage paid in the United States, Canada and Mexico. For other parts of the world, \$2.50, or ten shillings. Single copies, 20 cents. Remit by Express Money Order, Draft, Post Office Order or Registered Letter.

Mailing address can be changed as often as necessary—always give old and new address, and if you subscribe in a club, state who got it up. Please give prompt notice when your paper fails to reach you properly.

Entered at the Post Office, New York, as Second-class mail matter.

Copyright by Angus Sinclair Co., 1907.

For Sale by Newsdealers Everywhere.

## Power of Organization.

The rapid improvement in the condition of railway men is a source of gratification to all who have the best interests of the railway service at heart. From every part of the country comes the gratifying intelligence that wages are being increased, while the hours of labor are being diminished. In the opinion of RAILWAY AND LOCOMOTIVE ENGINEERING it is high time. It has long been a matter of comment that while the building trades have been enjoying the beneficent effect of the eight-hour law, railway employees have been working from ten to twelve, and in some instances even sixteen hours a day. This condition has been peculiarly exasperating in view of the fact that in point of skill, not to speak of attendant risk of life and limb, the demands of railway service have been far more exacting than anything essential to pass muster in the building trades. The causes that have led to this condition are not far to look for. The great bulk of the railways are in the hands of gigantic corporations. Workmen, far apart and unorganized, were literally helpless in the presence of colossal aggregations of capital. The

workman, skilled or unskilled, who cared to work for railways had to take what he could get. In the building trades large combinations of capital are almost impossible. In the great cities large bodies of workmen meet and organize readily, and it must be admitted that of recent years the men employed in the building trades have shown a fidelity to each other that is admirable in spirit and masterly in effect.

If the railroad corporations had been squarely met by a solid front of organized labor, there would have been another story to tell long ago. As it is, it must be said to the credit of the locomotive engineers and firemen that their organizations have shown what can be done in certain departments of railroad work. The object lesson which they furnish has not yet been properly learned by the machinists and blacksmiths and others of the great industrial army that are the necessary adjuncts of railroad activity. Rival organizations have created distrust and distrust has begot apathy and apathy has generated helplessness. In addition to this, a class of so-called workmen, who do not work, have hoodwinked and defeated the aims and ends of fraternal union. These professional agitators have kept up a kind of guerilla warfare, ordering strikes in small localities, draining workmen's earnings which were too low already, and in spite of the unvarying disaster that has generally befallen their feeble and erratic attempts at a betterment of conditions, they have invariably feathered their own nests, and few have ever returned to honest toil.

In the reports that are coming to us daily of the marked progress that is being made in the right direction there are two very notable features that should command respectful attention. In nearly every case the representatives of the corporations have shown a willingness to meet workmen who are selected by their fellows to present their claims. The corporations are opposed to meeting mere professional delegates. Men who come fresh from the engine, shop or forge or foundry command the respect and attention of the proudest and the highest. There is an eloquence that speaks in their horny hands, and if their tongues are not taught in the set phrase of parliamentary debate, there is an earnestness begotten of long hours of ill-paid drudgery that calls aloud for remedy. The other important feature is that the more reasonable and moderate the demands are the greater is the likelihood of the request blossoming into accomplishment.

In this connection mention must not be omitted of the two premier organi-

zations in the mechanical department of railroad work, the Brotherhood of Locomotive Engineers and the Brotherhood of Locomotive Firemen and Enginemen. It has largely been to the reasonable and conservative action of these brotherhoods that the status of the whole movement for organized labor has been raised in the eyes of labor employers and of the public generally, all over the country. These brotherhoods have shown an intelligent appreciation of conditions and have at the same time maintained what they considered was just with singleness of purpose. Without being belligerent or defiant they have studied the best interests of their own orders and have firmly but wisely and steadily pressed their claims. They have stood on their rights in the manly, fair play spirit of give and take, and have tempered their demands with reasonableness, and the result is to-day that there is hardly a railroad manager in the country who does not look upon such organizations as of positive value as a ready means of adjustment of differences, as an aid in standardizing work on the various divisions of a long line, as an upholder of discipline and as a co-worker with the company to build up that feeling of loyalty and faithful service without which no great industrial undertaking can be a complete success.

We believe in organized labor and organized capital, both are essential to the well being of civilization, and organized labor is infinitely the nobler of the two. Organized capital can well take care of itself. Organized labor requires advice garnered from experience and quickened into action that is at once gentle in operation and effective and beneficent in result. All progress is marked by danger and delay. The delay in bettering the conditions of railway men has been excessive. The dangers have arisen from distrust, from lack of unity of purpose, and in some instances from a lack of intellectual clearness that should see that rising to the heights of self-sacrifice is a sure path to ultimate triumph. A fine illustration of this latter quality was shown in the action of the Amalgamated Engineers of Great Britain in accepting the nine-hour day of work with a corresponding reduction of wages, the vast majority of the members believing that in a short time the wages would be increased. Their hopes were accomplished sooner than they imagined. The shorter hours necessarily created a demand for more men, and the demand for more men created higher wages. In America the future is full of hope for the railroad worker. Every indication points to the fact that the toiler is coming to a larger share of his own.

The spoilsman and the exploiter have had their day, and for the honest workingman there is surely coming more of the rewards that befit a higher plane of civilization. The achievement of to-day is but an augury for the future.—Auspicium melioris aevi—A pledge of better times.

**Museum of Security.**

Speaking of this kind of museum Dr. Holman in a recent article in the *Century Magazine* says, such institutions are of recent origin, the first having been opened in Amsterdam in 1893, in charge of a mechanical engineer, who is responsible for the supervision of machinery and its explanation.

Among the curious sights in Amsterdam there is one that will escape the tourist unless his attention is particularly directed to it. It is the "Museum van Voorwerper Voorkoming van Ongelukken en Ziekten in Fabriken en Werkplaatsen." Reduced to its lowest terms, this means in English the "Amsterdam Museum of Security."

The building contains a permanent exposition of apparatus and devices for the prevention of accidents in factories and workshops, so that manufacturers and all other employers of labor may see in actual operation the safety devices that guard the lives and limbs of their workers. This museum owed its origin to the Association for the Development of Manual Training and Handwork in Holland. The labor inspectors of Holland find that the museum is of the greatest service to them, because it meets every objection on the part of a superintendent that the safety device in question will interfere with the proper operation of his machinery.

In 1887 an important exposition of devices for the prevention of accidents to laborers was held in Berlin. An effort to preserve the valuable documents and other exhibits as a collection did not succeed at that time, chiefly through the failure of the government to cooperate. But in 1900 an appropriation of \$142,000 was made by the Reichstag for the creation of a museum of security. The Reichstag also appropriated \$75,000 in 1901 and \$43,750 in 1902. For the maintenance of the museum, which is in Charlottenburg, an appropriation of \$7,500 was made in 1902 and \$10,000 in 1903.

**Railroad Investigations in Germany.**

The German Government is alive to the problems presented in modern railroad operation and has been and is conducting a series of investigations concerning materials and devices for use in railways. In this connection we print below the substance of a letter re-

ceived from Mr. A. M. Thackara, the American consul-general at Berlin. The letter was in reply to an enquiry made by RAILWAY AND LOCOMOTIVE ENGINEERING for the purpose of ascertaining what was being done by the government of the Fatherland, and is valuable as giving accurate information, of what is being done in Germany at the present time.

"The Railway Administration in Germany has taken possession of a tract of ground at Oranienburg, about 18 miles from Berlin, and has built an experimental railway for the purpose of making various tests, and according to my informant the tracks of the experimental railroad form an oval, with a straight double track extension of 250 metres (820 feet), the total length of the line being 1,756 metres (5,761 feet). Electric motor cars are used, the current being supplied from the electric works of the town of Oranienburg. Experiments are made with different materials for bedding, with various kinds of rails, sleepers made of oak, pine and beech wood and of iron, in fact with everything which is used in track construction. Tests are also to be carried on with various systems of automatic block signals, switch-locking devices, electric, steam and benzine motor cars for railways, or in other words, the plant is intended to be a station for testing everything which would tend to increase the working efficiency of the German railway systems.

In this connection, statistics relating to the number of railroad accidents and the number of killed and wounded on the narrow and the standard gauge railways of Germany from 1900 to 1904, inclusive, will be interesting:

Year.	Accidents			Total.	Killed or Injured (1).	
	Derail- ments.	Colli- sions.	Other.		Killed (2).	In- jured.
1900..	634	356	2,769	3,759	994	2,447
1901..	555	302	2,440	3,297	881	2,038
1902..	554	248	2,454	3,256	851	2,055
1903..	477	258	2,385	3,120	878	1,979
1904..	538	309	2,648	3,495	953	2,167

(1) Not including suicides, the number of which in 1904 on the standard gauge railways was 260. (2) In the number killed are included those who died within 24 hours after the accident.

In 1904 there were 53,822 kilometres (33,444 miles) of standard gauge railways in Germany, of which 49,687 kilometres (30,874 miles) were operated by the State Railways Administrations, and 4,135 kilometres (2,570 miles) belonged to private parties; of the private roads 160 kilometres (99 miles) were also operated by the State Railway officials. In the same year there were 1,095 kilometres (1,239 miles) of narrow gauge road, 886 kilometres (550

miles) being operated by the State Governments and 1,109 kilometres (689 miles) by private concerns

The various German Railway Administrations make thorough investigations of every wreck, little or big, and invariably some one is held responsible and punished for their occurrence. The wreck on the Hamburg-Bremen line on New Year's night, in which 5 persons were killed and half a dozen injured, is regarded as a most serious affair. It will like all other accidents be sifted to the bottom. Exhaustive testimony will be taken with the thoroughness of a criminal trial and the cause will be inquired into with great thoroughness, the idea of the German railway managers being that detailed history of railroad accidents affords the best basis for taking precautionary measures for their avoidance in the future."

**Industrial Agreements.**

Among the mass of statistics and other matter published by the Department of Labor of the Dominion of Canada it is gratifying to find in the copy of the December *Labour Gazette* five or six pages devoted to the publication of an agreement in regard to the rules and rates governing the service of machinists and apprentices employed on the lines of the Canadian Pacific Railway system. A general adoption of the chief features of this admirable document among all railway machinists in America would be a decided step in the right direction. Machinists in the United States have generally looked upon their Canadian brethren as poorly paid, but we doubt if there are many better paid than the class specified in Article 6 of the agreement, which fixes the minimum rates at 37½ cents to 40 cents an hour according to location. It is also agreed that all overtime shall be paid at the rate of time and one-half, and that men called out to work after shop hours shall receive not less than five hours straight time. It may be noted that the men must be paid during shop hours. This means that the time occupied in the process of paying, is in working hours and not at night or during the noon recess. A bill embodying this clause was introduced by Assemblyman Degnan in the New York Legislature some years ago and failed to pass the Senate.

Indeed the details of the interesting agreement all point in one direction—that of a general betterment of the machinist trade, and in looking it over one could hardly suggest any change that would show a fairer spirit towards all concerned. With regard to the Saturday half holiday, it is gratifying to

see its observance has been established for one-half of the year, and while the average working hours remain about  $9\frac{1}{2}$  per day, assurances are given that the nine-hour day will be granted as soon as the Great Northern or Northern Pacific Lines consent to grant similar conditions. Mr. H. H. Vaughan, assistant to first vice-president, and Mr. Grant Hall, assistant superintendent motive power, have acted for the company in a spirit of liberality that is characteristic of gentlemen who have themselves risen from the ranks, while Mr. P. Kennedy, Mr. B. Hardy and Mr. J. H. Mathers, representing the machinists, have shown themselves worthy of the high trust reposed in them by their fellow workmen.

#### Technical Education of Apprentices.

The question of the supplementary education for railroad apprentices was taken up in a paper recently read before the St. Louis Railroad Club by Mr. S. M. Dolan, master mechanic of the Missouri Pacific shops at Sedalia, Mo. He is in a good position to judge of the merits of this question and of the advantages gained both by the young men and the railroad concerned as the Missouri Pacific have opened classes for the instruction of apprentices at Sedalia.

There is nothing new in the idea of affording boys who are learning a trade an opportunity to supplement their work by mechanical drawing and other studies, a knowledge of which is essential to their progress. In 1884 or '85 a school for apprentices was planned by Mr. John W. Garrett of the B & O., but either by reason of the indifference of the apprentices or from other reasons the scheme fell through.

At Sedalia at the present time there is a course of instruction for apprentices which is carried on in business hours without loss of time to the boys themselves. In this particular it is like the system adopted by the Central Railroad of New Jersey, in fact technical instruction has practically become part of the apprentice course.

The Sedalia class numbers about sixty and included boys from the boiler shop, machine shop, blacksmith shop and from among the electricians, tin and coppersmiths, painters and carpenters. The coach paintshop was used as the school room, and the boys were divided into classes with three to five members, without regard to the nature of the occupations followed, the foreman being consulted as to the time each boy could be spared. The co-operation of foremen was solicited and readily given, they being invited to spend at least fifteen minutes each day in the class room during the time boys from their

own departments were being instructed.

At the expiration of thirty days, a readjustment was made, the five most proficient boys were assigned to the same class. Soon after the work of instruction had been inaugurated, drawing instruments were offered to five students having made the best progress in the time. Much healthy rivalry was occasioned by this. The boys from the tin and copper shop having won by reason of extra work done voluntarily out of hours. Later on fountain pens were given to all who performed a certain amount of work during sixty days. Sixteen qualified in this contest.

The instruction was at first given by two young men with university training. Later the work was carried on by an instructor with university training, supplemented by correspondence school study. The shops at Sedalia were opened in October, 1905, so that practically all the boys were in their first year of apprenticeship. The rule for boys entering the company's employ in the Sedalia shops as apprentices is that each must pass successfully an examination consisting of four examples in arithmetic and must be proficient enough in spelling and writing to receive at least 75 per cent.

The subjects taught in the company's instruction classes include arithmetic, elements of algebra, common logarithms, geometry, trigonometry and drawing. This latter branch is taught as completely as possible. The time apprentices are withdrawn from shop work averages about 20 minutes a day. As the novelty wore off and as the lessons required some home preparation which involved a certain amount of self denial the interest of some began to flag. The laggards were taken to task by the master mechanic, one by one and kindly but firmly given to understand that regular attendance and progress in studies were as necessary as satisfactory service in the shop. Two left, rather than pursue their studies, and one was dismissed, his work in the shop justifying this course.

Mr. Dolan concluded his paper by reading letters from several of the foremen. These letters all showed that the system of technical instruction had the effect of making the boys take a deeper interest in their work. This was indicated by the fact that they asked more questions and seemed to observe and investigate matters on their own account more fully than they had done before.

The service thus rendered to the company was of a better quality, and to illustrate this we may quote the words of the machine shop foreman where he says: "In offering this advantage and compelling it, as we do

here in individual cases, the company is fortifying itself against incompetency."

#### Safety Appliances Exhibition.

The exhibition of industrial safety appliances held last month in New York was not a very large affair. It did not begin to compare with the display of locomotive and car material which may be seen each year at the meeting of the Master Mechanics and Master Car Builders' Association. The exhibits, however, comprised safety appliances for buildings, factories, processes, workshops, railways and indeed any art or craft where machinery or mechanical appliances are used. As a matter of fact railroad safety appliances were not very well represented, and some people might consider the show as rather disappointing.

The exhibition was free to the public and notwithstanding any drawbacks that there were, the promoters of the enterprise, the American Institute of Social Service, are to be congratulated on the fact that they got it going. We are certainly very much behind other nations in the attention we give to these things, and it is no small matter to have at least made a beginning, and the movement is in the right direction.

The idea is ultimately to constitute a permanent exhibition of safety appliances not for the purpose of exploiting the product of this or that concern, but one by which an observer can gain some knowledge of the state of the art. The exhibition to be as it were an "epistle known and read of all men." The museum of security is an accomplished fact in other lands, and as will be seen from the account, given in another column, by the American Consul-General at Berlin, the German government has established an adequate testing plant for the benefit of railway work.

In practically every civilized country there are departments of health; and further, milk, liquors and many foods are analyzed, the slaughter of animals is regulated, parks are provided, pure water is secured, free education is guaranteed and everywhere sanitary science is practiced. These things are done either by municipal or government agencies, and all are for the benefit of the public. The well being of any community is of paramount importance to the community itself.

Admitting that certain things are best done or should be done in this way for the common security and comfort and with an eye on the German railway testing plant, might not the establishment of some sort of a bureau of investigation prove beneficial to our people?

Speaking now from a purely theoretical point of view, good would almost certainly result from the establishment of some agency competent to intelligently ex-



amine appliances and claims and suggest improvement here or indicate a clearly defined want there. It might not be expedient or possible to test to a finality every invention of safety appliances which passed through the patent office, but such a bureau would be, in a measure, a sort of filtering basin toward which might flow the inventive genius of the nation, and from which the pure waters of demonstrated utility might be drawn for the service of the people.

There had been a great loss as far as inventive ability was concerned in the single matter of car couplers before the M. C. B. Association decided upon the vertical plane principle. As soon as the association set up this target before the railway marksmen of the country, fewer shots went wide and a great economy of effort and skill was at once apparent. It was definitely stated by the Association exactly what was wanted, and when interchangeability became essential, that quality appeared forthwith. A species of automatic elimination was thereby brought into being, and healthy competition along specific lines took place.

There could no doubt be much good work done by a bureau of investigation in indicating as did the M. C. B. Association the style and kind of thing that was desirable or possible of practical attainment, without in any way restricting the free inventive faculties of any one in the land. A reasonable expenditure for the testing of appliances judged by experts to have undoubted merit would largely assist in the solution of many an important problem. Among the appliances exhibited which are of interest to railroad men were rail joints and switches, boiler mountings, device for preventing the fall of workshop elevator, protection on wood-working machinery, emery wheels, etc. In all these devices safety was the prominent feature.

#### Scottish Railway Disaster.

The appalling disaster which occurred on the North British Railway near Arbroath, Scotland, whereby twenty-two people lost their lives, has been the subject of a special inquiry under a new Act of Parliament recently passed. The sheriff of the county acted as judge and the public prosecutor conducted the investigation before a jury. The purpose seems to be to place as speedily as possible the question of fault, if any, and on the jury's finding future actions for damages are necessarily based.

The act of Parliament empowering the local authorities to make official investigation does not supersede the inquiry of the railroad department of the Board of Trade. The act has, in fact, grown out of the recommendation of the board. The object of the Board of Trade inquiry in Great Britain is in order to properly place the responsibility

for any railroad disaster where it belongs and this is for the purpose of advising Parliament in order that all the facts in each case may be known and that legislation, where necessary, can be passed.

The causes of the accident were unusual. A terrific storm had raged on the east coast of Scotland, being the nearest approach to a blizzard seen in that country for many years. A passenger train running from Edinburgh to Aberdeen had been stalled at Arbroath about half way and after waiting for five or six hours the local railway officials had decided to send the train back to Edinburgh. The train was crowded, most of the passengers desiring to return to Dundee for the night. A freight train had left for the south some time previously and it never seemed to have occurred to any one that the freight train might meet with obstructions in the terrible snowstorm.

The freight train had only gone a few miles before becoming stalled in the blinding storm. Meanwhile the heavy passenger train came at a high speed and struck the freight train with such force that the entire train of passenger cars was derailed and almost demolished. Many of the victims of the disaster lay exposed to the storm for six hours before being relieved. Between the freezing storm and the consequent fire, the scene was of the most appalling kind. The utter absence of wrecking tools at any of the local stations has been the subject of much comment. The jury found the engineer at fault in not observing instructions more closely, although it was evident to everybody that it is doubtful what his instructions really were. They also severely condemned the absence of fog signals on the line. The Board of Trade will, however, proceed with the usual inquiry.

#### Cuban Railways.

In spite of the political disturbances which continue to keep the Island of Cuba in a condition of unquiet the commercial interests of the island have developed amazingly in the last two or three years. The United Railways of Havana have extended and consolidated the various railways until there are now in operation over 700 miles worked by the United Railways. Branches are being rapidly extended into new and fruitful districts. The rail distance between Havana and Cardenas has been considerably shortened. The relaying of rails has been general all along the older lines, while the rolling stock, both passenger and freight, has been vastly improved and several of the largest bridges renewed with steel spans. The Cuban Central Railway Company are making extensive surveys and in a few

years a network of railways will cover the island. The locomotives and cars are almost all from the United States, but the leading repair shops are already reconstructing some of the older engines.

#### Book Notice.

The Six-Chord Spiral, by J. R. Stephens, C.E. Published by the Engineering News Publishing Co., New York, 1907. Cloth, \$1.25; board, \$1.00.

Mr. Stephens, a civil engineer of recognized ability and experience in Colorado, has performed a notable service in civil engineering by producing a work of real value to engineers, especially to those who may be engaged in surveying railway tracks. The six-chord spiral is an ordinary multiform compound curve of six arcs of equal length, the degrees of curvature increasing in the order of natural numbers, and so arranged that the seventh arc always exactly coincides with the main circular curve. Intermediate transit points may thereby be set at any plus without incurring complex deflection calculations. The first part of the book explains the proper methods calculated to insure consistency with varying conditions of speed and curve. The second part deals with methods for shifting old tracks to make room for spirals and points out that this question is entirely independent of the kind of spiral used. The book will immediately take its place among the standard works that are most useful to engineers engaged in railway construction.

#### The Prosperous Erie.

More than 7,500 cars are now in process of construction to add to the freight equipment of the Erie Railroad. These include 3,000 box cars being built by the American Car & Foundry Co., 500 produce cars now in process of delivery by the same company, 3,000 steel hopper gondolas of 100,000 pounds capacity for coal carrying, 500 flat cars and 500 drop end gondolas, all for the transportation of heavy bulk freight.

The Erie has also placed an order for 35 freight locomotives, which, added to the 200 engines delivered during the past year and the 3 Mallet articulated locomotives of 410,000 pounds weight and a tractive effort of 98,000 pounds each—the heaviest and most powerful locomotives in the world—will put the Erie in possession of the best motive power it has ever possessed. With the delivery of this equipment, the Erie will be able to handle rapidly all the freight offered it for transportation.

Five new mail cars, 10 cars for livestock express service and 70 new passenger coaches, the latter building by the Pullman Company, are also to be added to Erie's equipment for special services.

### Mikado for Woodward.

The Baldwin Locomotive Works recently turned out an engine of the 2-8-2 type, which is sometimes spoken of as the Mikado type. The engine is for the Woodward Iron Company and is intended for work on a 4 per cent grade and with 15° curves. We are informed that the performance of the engine has been excellent and that a train of 1,350 tons has been pulled up a one per cent grade five miles long from a dead stop at the bottom.

The engine is a simple one with cylinders 22 x 28 ins. and 51 in. drivers, of which there are four pairs. The tractive power with 200 lbs. boiler pressure is 45,150 lbs., and as the weight carried on the drivers amounts to 173,500 lbs., the ratio of tractive effort to adhesive weight is as

beam and the step and a few feet behind the rear tender wheel out to the coupler, so that it is probable that if this engine was turned round as on a turntable it would sweep out a circle about equal in area to its own heating surface. The circle would be about 64 ft. in diameter. The weight of the engine itself in working order is about 209,700 lbs., and of this 21,600 lbs. rest on the engine truck and 14,600 lbs. on the rear truck. The grate area is 57 sq. ft., the firebox being 114 ins. long by 72 $\frac{3}{8}$  ins. wide. It is 61 ins. deep at the back and 72 $\frac{3}{8}$  deep in the front. The ratio of grate area to heating surface is as 1 to 57.8.

The tender is carried on the regular steel frame, and the tank, which is of the U-shaped type, holds 7,000 U. S. gallons and 11 tons of coal. There are

### New Susquehanna Bridge.

The new bridge over the Susquehanna river near Perryville on the Pennsylvania Railroad has been completed. The bridge is nearly a mile long, is part stone and part iron. The constituents of this structure are 44,360 cu. yds. of masonry and more than 10,000 tons of steel.

The new bridge, which is about 150 ft. north of the old one, is of graceful design, and consists of eighteen spans, one of which is a swing span 280 ft. long. Sixteen piers are built of Alleghany Mountain sandstone with concrete backing and Port Deposit granite coping. The fender at the swing span is built of piles with a granite pier at the north end and a timber crib, filled with stone, at the south end. The bridge is a fine looking structure, and one which will greatly add to the facilities of working the traffic of the road.

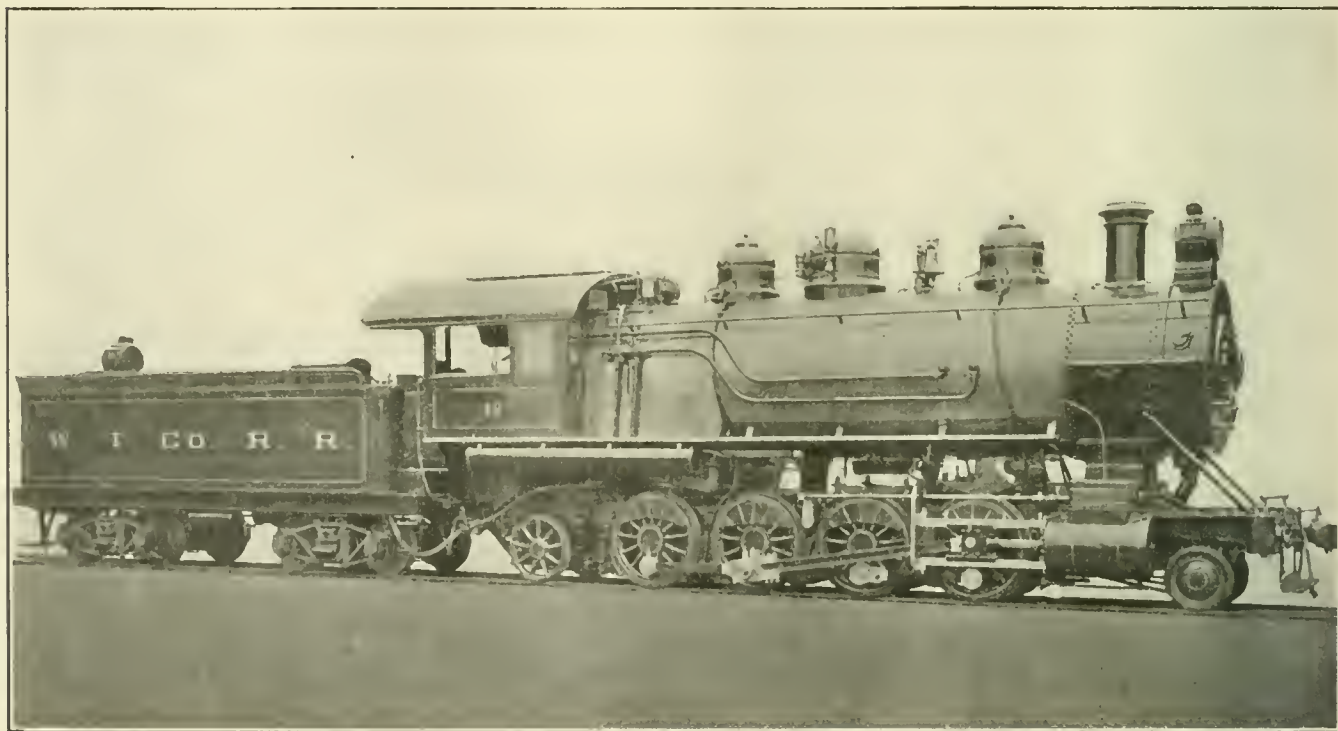

SIMPLE, BALDWIN ENGINE 2-8-2 FOR THE WOODWARD IRON COMPANY.

1 to 3.8. All the wheels under this engine are flanged. The pony truck and the leading drivers are equalized together and the other drivers and the trailing truck are equalized together. The valves are ordinary balanced D-slide actuated by Stephenson link motion, the eccentrics being on the main driving axle, which is the third pair.

The boiler is a straight top one with wide firebox. It is 79 ins. in diameter at the front end. The tubes are 406 in number, each 14 ft. 9 ins. long. They give a heating surface of 3117.7 and with the 182.3 sq. ft. in the firebox make 3,300 sq. ft. in all. The wheel base of the engine and tender is 57 ft. 10 ins. There is a certain amount of overhang in the front for the buffer

two 18-in. electric headlights, one in front and one on the back of the tender. Some of the principal dimensions are as follows:

Boiler—Thickness of sheets,  $\frac{7}{8}$  ins.; fuel, soft coal; staying, radial.  
 Fire Box—Thickness of sheets, sides, 5-16 ins.; back,  $\frac{3}{8}$  ins.; crown,  $\frac{3}{8}$  ins.; tube,  $\frac{1}{2}$  ins.  
 Water Space—Front, 4 ins.; sides, 4 ins.; back, 4 ins.  
 Driving Wheels—Journals, main, 9 $\frac{1}{2}$  x 12 ins.; others, 9 x 12 ins.  
 Engine Truck Wheels—Diameter, front, 28 ins.; journals, 5 $\frac{1}{2}$  x 10 ins.; diameter, back, 36 ins.; journals, 6 x 10 ins.  
 Wheel Base—Driving, 14 ft. 6 ins.; total engine, 29 ft. 0 ins.; total engine and tender, 57 ft. 10 ins.  
 Weight—Total engine, 209,700 lbs.; total engine and tender, about 345,000 lbs.  
 Tender—Wheels, diamct r., 33 ins.; journals, 5 $\frac{1}{2}$  x 10 ins.; service, freight.

Many think they are defending faith when they are only fighting against the necessity of thinking.

The fourth annual meeting of the Railway Storekeepers' Association will be held at the Auditorium Hotel, Chicago, Ill., on May 20th, 21st and 22d, 1907. This association, though not as old as some others in the railway field, is nevertheless making progress in the right direction. Mr. N. M. Rice, of the Atchison, Topeka & Santa Fé, at Topeka, Kan., is president. Mr. Josselyn, of the Burlington Lines, Omaha, Neb., is first vice-president. Mr. J. H. Callaghan, of the Canadian Pacific at Montreal, is second vice-president. Mr. J. W. Taylor, of the C. M. & St. P. at West Milwaukee, Wis., is treasurer, and Mr. J. B. Murphy, Collingwood, Ohio, is secretary. This meeting promises to be very interesting and will probably be largely attended.

# Our Correspondence School

In this department we propose giving the information that will enable trainmen to pass the examination they are subjected to before being promoted. If any of our students fail to understand any part of the instructions, we will gladly try to make them plainer if they write to us. All letters intended for Our Correspondence School ought to be addressed to Department E.

### Third Series—Questions and Answers.

261—How do you understand the other reading: "Extra 569, north, and extra 231, south, will meet at Kings Mountain?"

A.—Trains receiving these orders will run with respect to each other to the designated point and there meet in the manner provided in the rules.

262—Which one would take siding?

A.—The train moving in the inferior direction would take the siding.

263—As conductor or engineman of No. 1 holding orders reading: "No. 1 will pass No. 3 at Oakdale." How would you be governed?

A.—As conductor of No. 1, would approach Oakdale prepared to stop unless No. 3 could plainly be seen in the siding and standing clear and the switches set all right for the main line.

264—What would you do if on No. 3?

A.—If on No. 3 would run according to rule to Oakdale and arrange for No. 1 to pass promptly, No. 3 taking the siding.

265—As conductor or engineman of No. 32 holding order reading: "No. 42 will run ahead of No. 32 from Chattanooga to Oakdale." How would you be governed?

A.—No. 32 would run from Chattanooga to Oakdale behind No. 42, but must not exceed the speed of No. 42, between Chattanooga and Oakdale.

266—If on No. 42 how would you proceed?

A.—If on No. 42 would proceed according to rule ahead of No. 32 between the designated points.

No. 267—No. 1 had right of track over No. 2 to Lexington. What would you do if on No. 1?

A.—This order gives No. 1 the right of track over No. 2 as far as Lexington and No. 2 must look out for and clear No. 1 until Lexington is reached.

268—If on No. 2 what would you do?

A.—This order should specify the portion of road over which the order conferred the right of tracks, as for example, "Waverly to Lexington." Suppose the order to read correctly, if on No. 1, this order would give to No. 1 the right of track from Waverly to Lexington over No. 2. If the trains met at either of the designated points, No. 1 must take the siding.

269—Under this order, how much are trains of the same class required to clear each other?

A.—At meeting points of trains of the same class, the inferior train must

clear the superior train before the leaving time of the superior train.

270—Suppose No. 2, under the circumstances, went beyond the point named in the order, what would you be required to do when you met No. 1?

A.—No. 2 would be required to be in the siding at the intermediate point and switches set for the main line previous to the leaving time of No. 1 from that intermediate point.

271—Suppose you were running a train, and received orders giving you the right of track to some specified point against some train of superior right, and after arrival at that point you found you could go still farther, upon your own schedule rights, what would you do?

A.—I could proceed, keeping clear of

has right of track over all trains between Moreland and McKinney from 7 A. M. until 7 P. M.

A.—Work train Extra 275 has absolute right of track over all trains between the designated points for the designated time.

275—On work train, how would you be governed?

A.—Would work between the designated points and for the designated time regardless of all trains.

276—Suppose you were on train No. 2, and received an order that train No. 1 had right of track over you to Whitley, and the two trains meet at that point, which one takes siding?

A.—Train No. 1 would take the siding at Whitley.

277—How do you understand an order reading: "All regular trains have right of track over No. 1 between Junction City and Lexington?"

A.—The order must be understood to convey the right of track to all timetable trains without reference to class or directions over No. 1 between the points designated in the order.

278—How would you understand an order reading: "No. 1 will run twenty minutes late from Lexington to Somerset?"

A.—This order makes the schedule of train No. 1 twenty minutes later than that given in the time table between Lexington and Somerset, and any other train receiving the order is required to run with respect to this later time as it was before required to run with respect to the regular schedule time.

279—How do you understand an order reading: "No. 2 will wait at Junction City until 10:30 P. M. for No. 9?"

A.—Under this order No. 2 must not pass Junction City before 10:30 P. M. unless No. 9 has arrived, and No. 9 is required to run with respect to the time specified at the designated point, Junction City, or any intermediate station where the schedule time is earlier than that specified in the order, as it was before required to run with respect to the schedule time of No. 2.

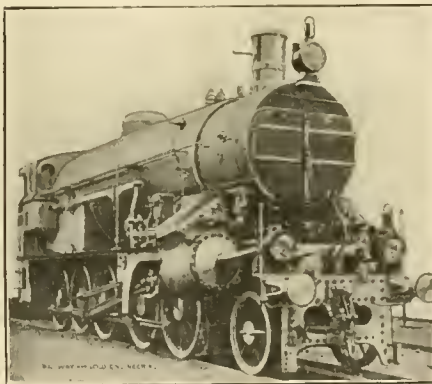

AUSTRIAN COMPOUND.  
(Gölsdorf System.)

the opposing train as many minutes as my train was required to clear the opposing train under the rules. The conductor of my train would have to stop the opposing train where it was met and inform it of our arrival and identity at that point.

272—Suppose you were running a train, and received an order that an extra had right of track to a certain point against you, could you go beyond that point before the extra arrived?

A.—No, because the extra's time is not restricted by the time card.

273—What would you do if on the extra?

A.—If the opposing train was an extra I would not pass the designated point until the other train had arrived. If the opposing train was a regular train, we could proceed if we had running time and ample clearance to reach some intermediate point.

274—How do you understand an order reading: "Work train Extra 275

The alloys of lead, tin and bismuth show peculiar properties. A mixture consisting of two parts of bismuth, one part of tin and one part of lead melts at a temperature a little below 212° F. It also has the quality of expanding on cooling. It is very useful in filling blowholes in castings, and is also used in taking delicate impressions of dies.

Calculations for Railway Men.

SOMETHING ABOUT JIB CRANES.

BY FRED. H. COLVIN.

The question of jib cranes has come up and in order to answer this in the plainest manner I am going to use graphics, in other words draw the

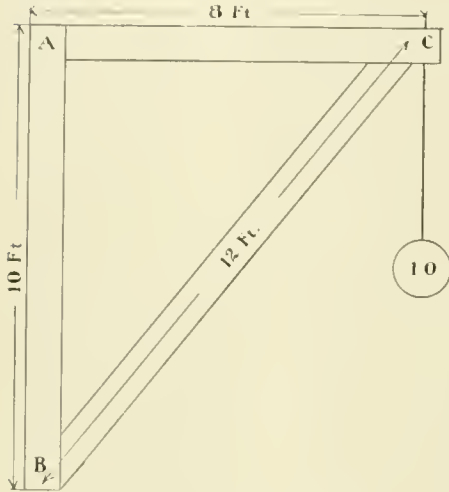

FIG. 1. ORDINARY JIB CRANE.

whole thing in as few lines as possible and make these lines do all the figuring or as much of it as possible, which will leave very little for the usual kind. Let us take a plain jib crane such as adorns many a foundry and as shown in Fig. 1. This is supported top and bottom in some safe way which we will not go into as we are not design-

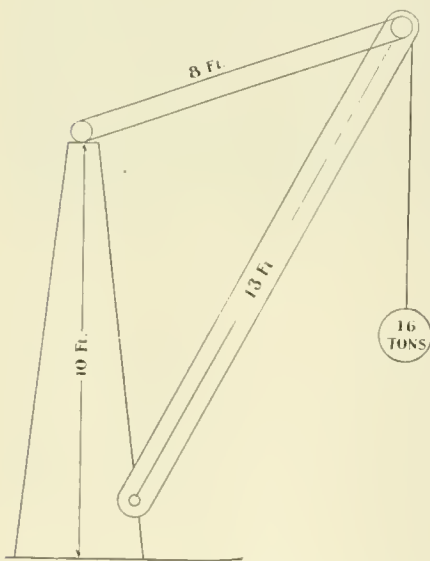

FIG. 3. WRECKING TYPE OF CRANE.

ing cranes. It has an 8 foot arm, is 10 ft. high and that the strut is 12 ft. The full load is 10 tons or 20,000 lbs. What is the strain at the different points when fully loaded?

We will forget all about inch pounds and bending moments for now, and

draw what is called a "stress diagram" as shown in Fig. 2 and this should be drawn on as large a scale as you can, on your drawing board, or on a board or anywhere else, a sheet of metal is an excellent place. In this stress diagram we are not dealing with feet and inches but tons, and first draw a vertical line to left representing 10 tons; this can be made 10 inches long with advantage. Draw the other lines at exactly the same angles to this that the different members of the crane are to the upright and measure these lines by the same scale. That is draw BC in Fig. 2 at the same angle to AB that BC is to AB in Fig. 1. This will give you the triangle as shown in Fig. 2, and we then measure the different lines and find that the top line measures 8 inches (assuming that we have used one inch to represent a foot) and that BC measures 12 3/4 ins. These represent tons stress in the different members as follows:

The horizontal stress in AC which tends to pull the crane over toward the load at the top, is 8 tons. The stress in the strut or support is 12 3/4 tons or 25,500 pounds. This is in compression or is pressed at both ends and carries the load as it supports the upper arm right under the load.

This member then must be strong enough to stand this end pressure and it is plain that a chain or rope would answer equally well in place of the timber above. As this is a rather short strut, only 12 ft., we can allow about 1,000 lbs. pressure to the square inch on this, so we divide 25,500 pounds by 1,000 and get 25.5 square ins. of good oak timber to stand this strain safely. A 5 by 5 timber gives 25 square inches and might safely do the work but it is better to have it a little deeper than it is wide to offset any tendency to sag under the load, and we would make it either 4 wide by 7 deep or 5 wide by 6 deep, the latter being the stronger of the two. If we used a rope for the top member instead of the beam, we find from a table of wire ropes that a galvanized wire rope made up of 6 strands of 2 wires each will break at 38,500 lbs., and as 8 tons is 16,000 lbs., this gives us quite a leeway for safety. But it pays to be on the safe side and a still larger rope might be selected instead.

This brings us to a crane of the wrecking type like that shown in Fig. 3. This should be figured for different positions of the boom to be sure it is strong enough for the position in which it carries the most load, but we take the position shown and work it out as it is a little different from the other example. Here the load is 16 tons and we draw the vertical line AB 16 inches long, if convenient, or 16 half inches as

the case may be. Then draw the other lines at the same angles as the others, the same as we did before and we get BC and AC. Measuring up these lines we find that the stress in AC,

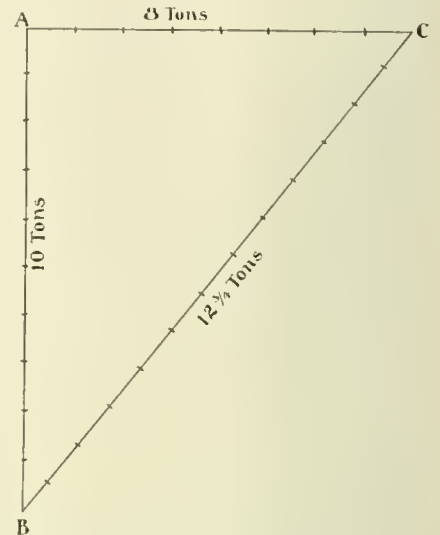

FIG. 2. SKELETON DIAGRAM OF ORDINARY JIB CRANE.

which is in the hoisting rope, is 13 1/2 tons in this position, that it is 24 tons in the strut BC and that the horizontal pull is 13 tons as shown. The distance between A and D shows the upward pull on the base of the crane to be 4 1/4

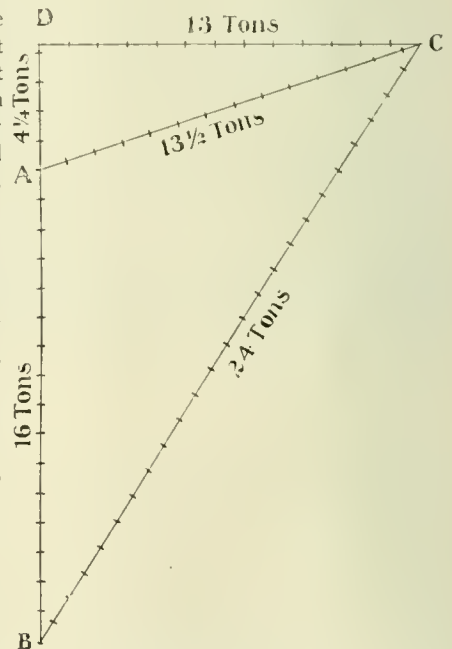

FIG. 4. SKELETON DIAGRAM OF WRECKING CRANE.

tons, tending to lift it from the car or wherever it is anchored.

The same line of figuring can be followed as before except that we should reduce the allowable stress in the timber for the strut owing to its being a little longer and also being subject to shocks which it would not receive in

connection with the timber support above as in the case of the other crane.

In this case it would be well to reduce the allowable stress to 800 lbs. per square inch for that strut timber. As the stress is 24 tons or 48,000 lbs., we divide this by 800 and get 60 square inches as the size of this, which gives a 6 by 10 or a 7 by 9 as is thought best. In the same way we find the size rope for the strain of 27,000 lbs. from the table of wire rope, not forgetting that this stress is lessened for every time it goes around the pulley blocks and also allowing for wear from this very cause. A galvanized wire rope 4.11 inches in circumference has a breaking strength of 75,000 lbs. for a single rope, but as this will have at least four ropes (two turns around each pulley), we can use one much smaller. This shows that a rope 2.46 inches in circumference or less than an inch in diameter will do the work.

## Questions Answered

### H BRAKE VALVE BLOW.

(19) J. F. C., East Buffalo, N. Y., writes:

I am firing an engine that has the E T brake on the engine and tender, and when the handles of both brake valves are on running position there will be a short blow at the exhaust of the automatic brake valve every once in a while. If the straight air valve is lapped the brake will go on. What makes it act that way? A.—In cases that we have noticed, where the action of the E T brake was similar to that which you cite, we have found a sluggish acting feed valve and an excessive brake pipe leakage, working together, produced a mild blow at short intervals at the automatic brake valve. The feed valve would charge the brake pipe to 70 lbs., then close, and would not open again until the brake pipe pressure had reduced from 3 to 5 lbs., and as this leakage caused the reduction to take place rather quickly in the brake pipe pressure, the equalizing valve in the distributing valve would operate and admit air to the application chamber; then the reducing valve would open, charge up the brake pipe, and return the equalizer valve to release position, thus permitting the air in the application chamber to escape to the atmosphere at the automatic brake valve exhaust. By placing the independent brake valve handle on lap the air in the application chamber could not escape each time the equalizing valve returned to release position, but remained trapped in the application chamber; hence when the independent valve was lapped the brake would apply.

### BROKEN APPLICATION CHAMBER PIPE.

(20) E. J. K., Altoona, Pa., writes:

In case of the pipe connecting the independent brake valve and the distributing valve breaking off, what effect will it have on the working of the brake and what must be done to remedy it so as to get in? A.—That is the application chamber pipe, and if it breaks it will put the brake out of commission on the engine only. To get in and work the brake the connection at the distributing valve reservoir must be plugged tight, and the double heading pipe disconnected. You can then operate the brake with the automatic brake valve, but not with the independent brake valve.

### FALL OF PRESSURE.

(21) T. C., Caspar, Cal., writes:

I have noticed sometimes when drifting and filling the boiler, hot fire in furnace, that the pressure would not drop, but upon opening the blower the steam would drop 10 or 15 lbs. A.—When you shut off steam the fire is not stimulated by the action of the exhaust, as the blast ceases and the generation of steam is reduced. It is also somewhat checked by the action of the injector, but this may not become immediately apparent on the gauge, but it will show after a little while. When the blower is put on, especially if the blower pipe is taken off the boiler near the steam gauge pipe, a local reduction of pressure may be caused which more quickly shows on the gauge.

### DOUBLE-HEADING WITH E. T. BRAKE.

(22) R. S. W., Syracuse, N. Y., writes:

I had a peculiar experience with a double header where both engines had the new E. T. brake. I could release all brakes except those on the second engine O. K., but these would stay set. What was the matter? A.—Probably the man on the second engine neglected to place the handle of his brake valve on lap after he closed the brake valve cutout cock. In all cases of double heading, where the engine not operating the brakes is equipped with the E. T. brake, the handle of the automatic brake valve should be placed on lap after the brake valve cutout cock is turned to the closed position. This opens up the distributing valve application chamber exhaust to the atmosphere, so that the air in this chamber can escape when the man operating the brake places the handle of his brake valve in release.

### POSITION OF REVERSE LEVER.

(23) M. D., Scranton, Pa., writes: In running a locomotive down grade without steam should the reverse lever be hooked up or put in the forward notch?—A. The lever should be placed in the forward notch for the reason that in a hooked-up position a partial vacuum will be formed in the cylinder while the piston is moving from the point of cut-off to the point of release, and when the exhaust

port is opened, the cinder-laden gases from the smoke-box rush into the cylinder. The compression induced by the short travel of the valve also has the pernicious effect of lifting the valve off its seat and causing a clattering of the valve as it rises and falls on the valve seat. Opening the cylinder cocks relieves this trouble, but rapidly cools the cylinder.

### GRADUATING OFF THE E. T. BRAKE.

(24) B. R. T., Hartford, Conn., writes:

When handling passenger with the new brake valve that holds the brakes on the tender and engine, I notice that you can jar the train at the stop if you release the brakes on the train and don't let them off on the engine. Which is the best way to handle this brake to make a smooth stop? A.—It is quite true, if you do not graduate off the locomotive brakes properly, when you release the train brakes (passenger) before coming to a stop, you will experience a jar or "kick back" on the train, but there is no good reason why you should not graduate off completely the locomotive brakes just as the stop is accomplished and make a smooth stop without the "kick back" complained of. In handling the brakes with the H brake valve (E T brake), the following is a good method to observe when releasing and it will, we think, enable you to do perfect work: Always hold the handle in release position long enough to allow all triples in the train to go to release, then move it to holding position—whether you wish to hold the locomotive brakes applied or not—then graduate off between holding and running positions or release entirely as the circumstances require. Don't try to graduate off between release and running position, but always between holding and running position.

### STEAM TEMPERATURES.

(25) J. A. W., New Orleans, La., writes:

Will you please state through the columns of RAILWAY AND LOCOMOTIVE ENGINEERING what is the approximate temperature of steam as it passes through the throttle valve, and when it leaves the tip of the exhaust nozzle in a simple locomotive with the working steam pressure of 180 lbs. to the square inch? A.—The temperature of steam at 180 lbs. pressure as measured on the steam gauge is just about 379½° F. This may be said to be the temperature of the steam passing through the throttle. Suppose the steam to be expanded down so that it leaves the cylinders at 5 lbs. gauge pressure the temperature of that steam would be close on 228° F. Look up the table of the properties of saturated steam in Kent or any good engineering pocket book.

### ANGULARITY OF THE CONNECTING ROD.

(26) F. L. B., Wilmington, Del., writes: Will you please tell me in your

Questions Answered column what is meant by the angularity of the main rod?

—A. The angularity of the connecting rod may best be explained by following the rod in its movements through one revolution of the driving wheel. When the crank pin is on the forward quarter the piston is at the forward end of the cylinder, and crosshead and wrist pin are in their extreme forward position. When the crank pin comes to the bottom quarter, it will be found that the crosshead has passed over a little more than half of its stroke. When the crank pin reaches the back quarter, the crosshead will be at the end of its stroke. When the crank pin arrives at the top quarter the cross head will be found to have traveled slightly less than half its stroke and will be in the same position that it was in when the pin was on the bottom quarter. When the pin arrives at the forward quarter, having made one complete revolution, the crosshead will be in its extreme forward position again. The crosshead has therefore traveled over unequal distances for each quarter point of a half revolution of the wheel, the first and last quarters having the greater crosshead movement and the second and third quarters the less. This is due to the angle made by the connecting rod as the butt end travels with the pin and the small end moves with the crosshead.

#### FIVE-POUND REDUCTION K TRIPLE.

(27) J. R. O'D., Hazleton, Pa., writes: I would like to ask a question on the air brake. In reading an account of the K triple I always see it mentioned that a 5-lb. reduction will apply the brakes nearly full or equal to a 20-lb. reduction with the old triple valve. Can you apply the brakes on a 60-car train with less than a 5-lb. reduction and get all the brakes on? A.—With the K triple valve, on long trains, a 5-lb. service reduction is equal in efficiency to a 20-lb. service reduction with the old triple. The quick service triple (K) has the advantage over the older type when making a service application on long trains, since if the service reduction be only 5 lbs., all brakes throughout the train will apply quickly and uniformly, and they will also develop sufficient cylinder pressure with this reduction, because of the brake pipe air that is put into the brake cylinder to produce an effective retarding force. With the older triples a 5-lb. reduction made on long trains, 50 cars or over, will not apply all of the brakes, and those that are applied do not develop any retarding power to speak of. Also those that do apply do so very slow and hence lose ground on this account. From the numerous tests that have been made with long trains fitted both with the K triple and with the ordinary quick action triple, it has been found that a 5-lb. service reduction with the former will stop the train in

the same distance that a 20-lb. reduction will with the latter, a slight variation from this result being noticeable only when the speed is higher than that usually attained by a long train on a level track.

With a full service application, under precisely similar conditions as to length of train, speed, load and grade, the quick-service triple will stop the train in from 40 to 60 per cent. less distance than will the older triple. While we have never made any tests to determine whether a 3-lb. service reduction will set all the brakes on a 60-car train, we incline to the opinion that it will. We should be pleased to hear from some of our readers on this latter point.

#### BALANCED ENGINE.

(28) R. E., Waterville, Ont., writes: Will you please tell how or why they call an engine like the Northern Pacific compound, described in your December, 1906, issue, as a balanced engine? What does it mean to say an engine is balanced?

—A. This engine is spoken of as a balanced engine on account of the arrangement of its cranks. As shown on page 542 of our December, 1906, issue, the right high pressure crank on the forward axle is on the top quarter, the left high pressure crank on the same axle is on the back quarter. When in this position the crank pin on the right centre driving wheel is on the bottom quarter, and the one on the left side is on the forward quarter. All the drives are connected by side rods, and when two pistons are in mid stroke the other two are on the dead points. When the right high pressure piston is moving forward the right low pressure piston is moving backward, and vice versa, and similarly with the cranks on the left side. The two cranks and the pair of crank pins give four points of application for the connecting rods, and each of these points is, so to speak, 90° apart.

#### COUNTERBALANCING.

(29) G. F. K., Moncton, Canada, writes:

We have a 37 in. wheel centre and a 43 in. tire. If we want the wheel to be only 42 ins. outside diameter will it throw the counterbalance of the wheel out any more to cut down the centre to 36 ins. or put on a 42 in. tire than it will to put on a 43 in. tire on the 37 in. centre and turn down the tire to 42 ins.? A.—This is not a case of designing a new counterbalance or of finding the place where the counterbalance should go. We assume that the engine as originally designed was properly counterbalanced, and the counterpoise is fixed in a certain place. If you increase the diameter of the wheel by a new and heavy tire you do not disturb the effect of the counterbalance because the tire put on

balances itself all the way round, and so would a larger wheel if it was possible to add to the ends of the spokes and enlarge the rim. When you have the counterbalance all right for one size of wheel, you can put on a heavier or deeper tire, or you can turn off some of the wheel rim without affecting the counterbalance, as long as you do not cut into the counterbalance itself or alter it in any way.

#### VALVE PACKING AND BY-PASS BLOW.

(30) L. C. B., Covington, Ky., writes:

Can a by-pass valve blow, in a piston valve engine, be detected from a valve packing blow? A.—The distinguishing of these blows one from the other might be difficult for this reason: if you put the valve on the centre so as to block both ports and the valve packing was defective there would be a blow up the stack. If the by-pass valve leaked so that steam got down into one end of the cylinder there would be a blow from the cylinder cock at that end. If steam was able to leak from one end of the cylinder to the other there would be a blow from both cylinder cocks, like that from defective piston packing, but if the valve had any inside clearance steam would blow up the stack from one or both ends of the cylinder as the case might be, and the blow up the stack like that caused from a defective valve, and in this case it would not be easy to decide which it was.

#### AREA FOR BALANCE VALVE.

(31) L. C. B., Covington, Ky., writes:

Please explain how to figure the area of a Richardson slide valve and the port areas, and how to figure it out in a practical way so as to enable one to equip a plain slide valve engine with a Richardson balanced valve. A.—The rule which may be adopted in such a case as this is to take the area of the exhaust cavity of the valve and add to it the area of one steam port and the total area so found is the area which can be included within the inner edges of the strips. This area ought not to be exceeded, as otherwise the valve may be overbalanced. A lesser area may do according to circumstances. In this connection read "Leakage of Slide Valves" on page 18 of the January issue of RAILWAY AND LOCOMOTIVE ENGINEERING.

A new line is to be built from Minneapolis to the international boundary, which will furnish a short line to Port Arthur, Fort William and the Nipigan country in Ontario. It will be known as the Big Fork & International Falls. Its construction will make it possible for the run from Minneapolis to the boundary, to be made in a night—N. Y. Commercial.

# Air Brake Department

CONDUCTED BY J. P. KELLY

## The M Triple Valve

As the electrification of steam roads proceeds it is found necessary to modify in some important particular the air brake apparatus to make it meet the requirements in a highly satisfactory manner.

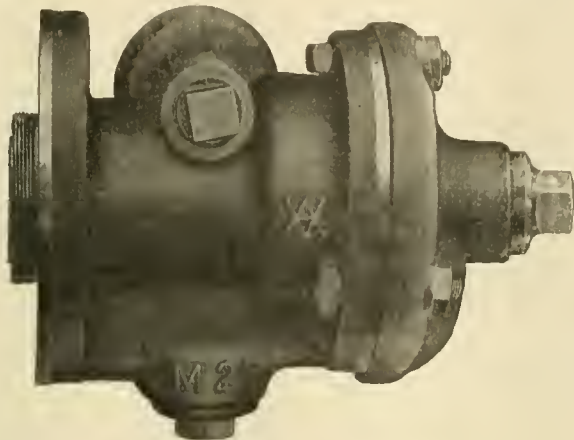

FIG. 1. THE M TRIPLE VALVE.

Thus in the electrification of the Rochester branch of the Erie Railroad it was found that the M triple valve illustrated herewith would best meet the requirements of the service of this branch. This triple, as may be seen from Fig. 1, is of the pipeless variety, that is, it bolts to a bracket located in some convenient place in the car and to this bracket all the pipe connections are made, so that when it is necessary to remove the triple for cleaning and repairs these connections do not have to be disturbed.

The M triple is of the plain type, similar to the F 1 or the H 24 plain triple, and it performs all of their functions. In addition it has the quick re-charge of auxiliaries, the quick service application of the brakes, the graduated release of cylinder pressure and the high pressure emergency features. Because of possessing these additional features it is a triple that is especially adapted to high speed passenger service where the trains do not consist of more than five cars.

A longitudinal and a cross section view of the M triple is shown in Fig. 2. This view gives us a clear idea of the internal construction, showing besides the familiar piston, slide valve and graduating spring, a graduating valve of the slide valve pat-

tern, mounted on the main slide valve; a high pressure emergency feature, consisting of a piston and a check valve and spring, placed on top, and cross wise, of the body of the triple; and the quick re-charge features which consists of a check

With the M triple there is used a control pipe or a control reservoir, whichever is deemed preferable, and it has a connection to the M triple at port x, so that at the same time air is passing through ports a, c and g and also past the small check valve through ports y, j and u, to chamber R air from the control pipe or the reservoir, as the case may be, is flowing through passage x and port k to chamber R and the auxiliary reservoir. Hence it will be seen that with air flowing through these three channels to the auxiliary reservoir, the latter will be quickly charged to maximum pressure after each release of the brake.

The service application position is represented in Fig. 5. The brake pipe and the auxiliary reservoir being charged to standard pressure in the manner just described, a service reduction in brake pipe pressure causes the triple piston, the slide and the graduating valves to assume the position shown. The main slide valve closes the brake cylinder exhaust, port M, also the charging ports k and j, and cuts off the control i pipe from the auxiliary. The triple piston cuts off the charging port i and the small check valve prevents the back flow of air through port y. The graduating valve uncovers ports z and r and auxiliary reservoir air flows through these ports to the brake cylinder; at the same time brake pipe pressure raises the check valve and allows brake pipe air to flow through port y into cavity v in the

valve spring located in the lower part of the valve body, and a control pipe or reservoir connection.

A face view of the graduating valve, a face and plan view of the slide valve, and a view of the slide valve seat are shown in Fig. 3.

For the purpose of making clear the operation of the M triple, use is made of the diagrammatic drawings, Figs. 4, 5, 6, 7 and 8.

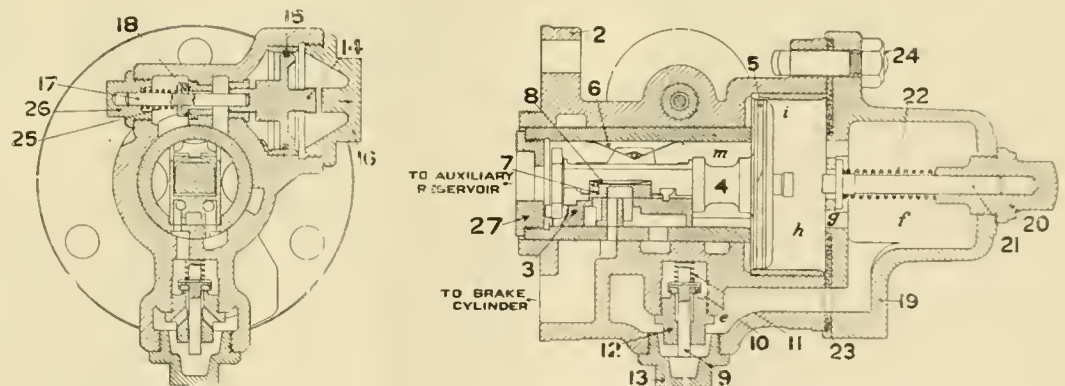

FIG. 2. LONGITUDINAL AND CROSS SECTION OF M TRIPLE VALVE.

The release position of the internal parts is represented in Fig. 4. Air from the brake pipe enters the triple through the passages marked a, c, and g, and it passes into chamber h, thence through the feed groove i into chamber R and the auxiliary reservoir. Brake pipe air also flows upward from passage a past the small check valve through ports y, j and u into chamber R and the auxiliary reservoir.

graduating valve thence through ports q and r to the brake cylinder, thus producing the quick service feature and economizing in the quantity of air used in making the brake application. This local venting of brake pipe air into the brake cylinder also causes a quick response of all the other triples in the train. The service lap position is represented in Fig. 6. As soon as auxiliary reservoir pressure re-

duces slightly below brake pipe pressure the triple piston and the graduating valve move to the position shown, closing all ports between the brake pipe and the

air passing into the control reservoir and into the auxiliary reservoir in charging is taken from the brake pipe through the feed groove *i* and ports *y*, *j* and *u* into

the extreme left, placing the slide and graduating valves in the position shown. Auxiliary reservoir air then flows past the end of the slide valve through port *r* into the brake cylinder. At the same time the auxiliary air is flowing through port *r* it also flows through ports *s* and *t*, and it forces the by-pass piston to the right. This operation opens the by-pass valve and the air from the control pipe is admitted through ports *x*, *x*, past the by-pass valve through ports *r*, *r*, into the brake cylinder. When the brake cylinder and auxiliary reservoir pressure become equal air continues to flow from the control pipe to both the auxiliary and the brake cylinder through port *r*. When the auxiliary, the brake cylinder and the control pipe pressure are nearly equal the by-pass valve will close and the by-pass piston will return to its normal position. The opening of the by-pass valve in emergency applications gives a much higher cylinder pressure than is obtainable with the standard quick action triple valve.

People who know little about a subject sometimes explain it more clearly than those who know all about it. An old sailor had heard in church an

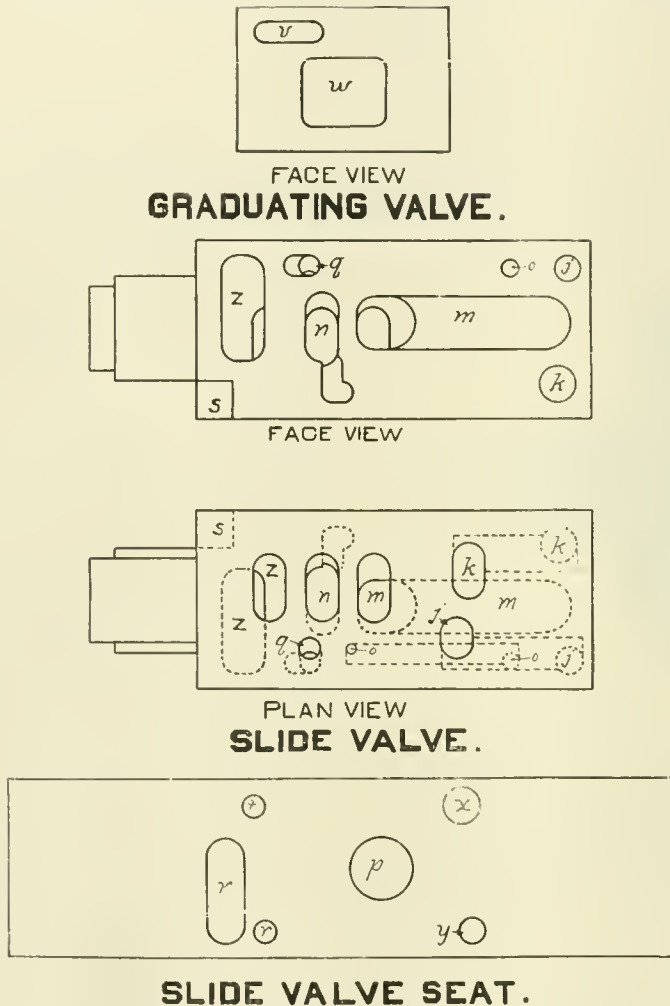

FIG. 3. DIAGRAMS OF THE VALVE AND SEATS M TRIPLE.

auxiliary, and between the brake pipe and the brake cylinder, so that the brake is held applied without increase or without decrease in cylinder pressure.

The graduated release lap position is represented in Fig. 7. If only sufficient air is thrown into the brake pipe to raise the pressure high enough to move the piston slide and graduating valves to release position (see Fig. 4) and then the brake valve handle is lapped, cutting off the supply of air to the brake pipe, the inflowing air from the control pipe through ports *x* and *k* to the auxiliary reservoir will raise the pressure in the latter slightly above that in the brake pipe; and then the piston and the slide valves will move to the position shown, closing all ports in the triple and retaining a portion of the brake cylinder pressure. The graduated release operation may be repeated until both the brake pipe and the auxiliary reservoir are charged nearly to maximum pressure. When a control reservoir instead of a control pipe is employed, the connection to the triple valve is made at port *x* as already stated, and all of the

the auxiliary reservoir, thence through ports *k* and *x* into the control reservoir, which is in this manner charged to the same pressure as the auxiliary. The pas-

sage between the auxiliary and the control reservoir is open only when the triple is in release position. The emergency position is shown in Fig. 8. When the brake pipe reduction is heavy and quick, the auxiliary pressure forces the triple piston to



JUST WORKING EVERY DAY.

anthem, which greatly pleased him. He was telling a shipmate, who asked, "I say, Jack, what's an anthem?" "What," replied Jack, "do you mean to say you don't know what a hanthem is?" "Not me." "Well, then, I'll tell yer. If I was to say to yer, 'Ere, Bill, give me that handspike,' that wouldn't be a hanthem. But was I to say, 'Bill-Bill-Bill-giv-giv-giv me, giv-me

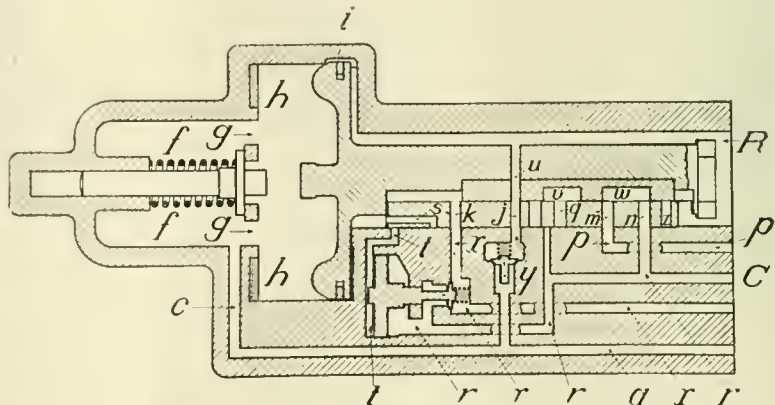

FIG. 4. RELEASE POSITION.

that, Bill, give me, that hand, give me that hand handspike. spike-spike-Bill-giv me that that hand-handspike, hand-spike-spike-spike, ah men; Bill give me that handspike-spike, ah men! that would be a hanthem."



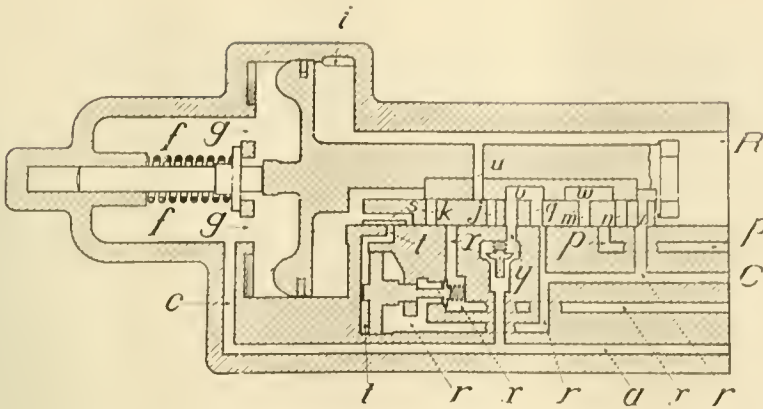

FIG. 5. SERVICE POSITION.

**Air Brake Convention.**

In a circular recently sent out to the members of the Air Brake Association by Mr. F. M. Nellis, the secretary, it is announced that the fourteenth annual convention of the association will be held in Columbus, Ohio, beginning at 9 a. m., Tuesday, May 14, 1907, which is one month later than the usual date.

The committee on arrangements and entertainment is composed of the following members: Mr. S. D. Hutchins, chairman, 1132 Columbus Savings and Trust building, Columbus, Ohio; Mr. William Holbrook, Mr. T. M. McGurty, Mr. J. E. Ganson and Mr. C. M. Kidd.

This committee has selected as convention headquarters the Great Southern

train of the orthodox four foot eight and a half inch gauge.

commodation and electric lighting, are provided. Stoppages for refreshments are made at convenient intervals, and Sydney is reached shortly before the middle of the day following the afternoon departure from Melbourne.

The time occupied in the journey of 582 miles is seventeen and a half hours. In going from New South Wales to Queensland a traveler would leave the New South Wales railway system at Wallangarra, 492 miles from Sydney, and he would then pass into a narrow gauge Queensland train, arriving at Brisbane, the capital of Queensland, about 7 A. M. on the day after leaving Sydney, the distance

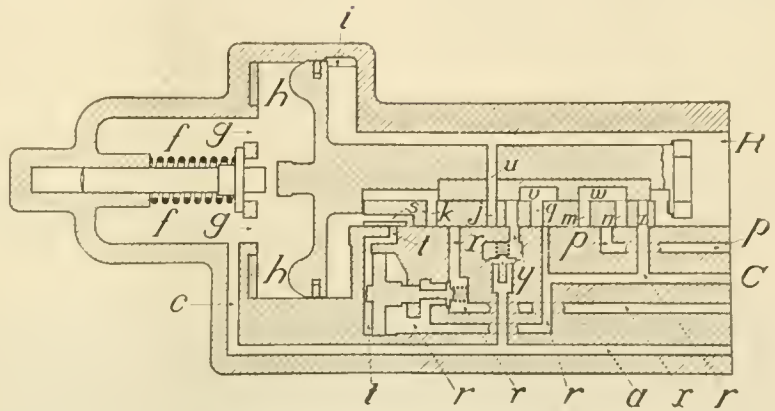

FIG. 6. SERVICE LAP POSITION.

of 725 miles being accomplished in twenty-eight hours.

**Runaway Train.**

On heavy grades there is always a strong tendency for trains to get from under the control of the crew, and for this reason the utmost care should be exercised, before commencing the descent, to ascertain if the brakes are in good working order, and also whether they are efficient or not.

To neglect to make the proper test before starting down, and to allow the speed, after starting, to increase to a high rate before commencing the brake application will, sooner or later, end in disaster, such as is shown in the illustration. "The Result of a Short Brake Pipe," which pictures what happened to a train of fifty-one cars, all air, on a grade of seventy-one feet to the mile, when it met an opposing train standing at a point about three miles from the top.

For some reason the air brakes did not

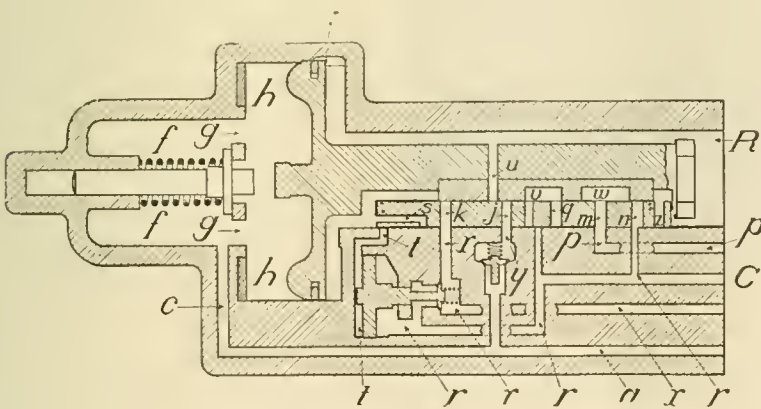

FIG. 7. GRADUATED-RELEASE LAP POSITION.

Hotel, located on the corner of High and Main streets, where ample accommodations will be provided for all who attend.

Pullman vestibule combined sleeping and drawing room cars and corridor first and second class cars, with lavatory ac-

**Railway Speed in Australia.**

The four chief towns of Australia—Adelaide, Melbourne, Sydney and Brisbane—are now connected throughout by railway, a total distance of 1,800 miles being accomplished by express trains in sixty-three hours. A visitor from Victoria to New South Wales enters the latter colony at Albury, on the southern border and 392 miles from Sydney. Albury is the changing place, where the traveler would have to leave a Victoria broad gauge train and enter a New South Wales

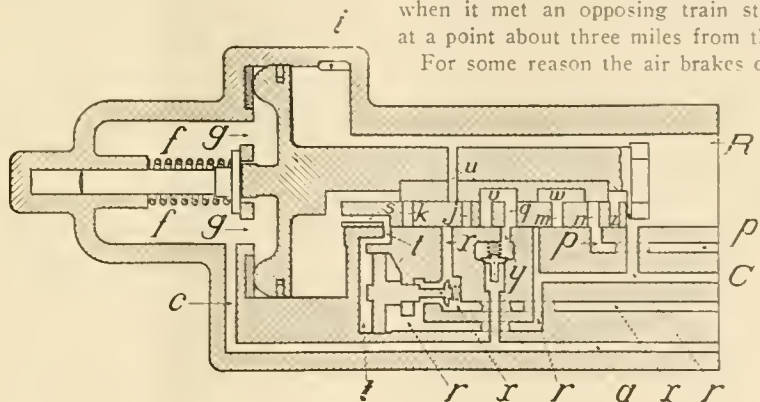

FIG. 8. EMERGENCY POSITION.

operate as expected, and the crew, not finding this out before the speed got too high, were unable to control it with the hand brakes.

Most of our readers undoubtedly know what is meant by the term "co-efficient of friction," and they also know that at speeds of twelve miles per hour, or under, it is seldom less than twenty per cent. of the brake shoe pressure, while at speeds of twenty-five miles per hour the co-efficient drops to twelve per cent., and sometimes to a lower figure. This simply means that if brakes are applied while speed is not over twelve miles per hour they are nearly twice as effective in retarding the motion of the train as they are when applied with the same pressure at a speed of twenty-five miles per hour, or over.

These facts every trainman who is in

pains with them in order that they may move easily on the crankpins at the extreme ends or dead centers. With the main rod, however, the same care is not so often taken. It is, as a rule, simply bolted up into place, and the number of times that the large end of the main rod gets heated in running is very much in excess of the number of similar occurrences on any other bearing on the rods. The trouble has its origin in the fitting, or rather the want of fitting, in the case of the front end of the main rod.

The wrist pin bearing is one of the bearings which must be snugly fitted on account of its not making a full revolution; it has a particularly binding effect on the other end of the main rod. A little thoughtful work in adjusting the front end is always necessary and should be proceeded with deliberately. The

The main rod strap should be attached to the crank and the main rod slid into the strap. Before entering the flange of the brass, it can readily be seen whether the large end of the main rod is exactly flush with both the upper and lower portions of the forked strap. This is very rarely the case and a refitting of the front end brass is again necessary before an exact adjustment of the two bearings can be made. It is then necessary to loosen the front end and attach the butt end of the main rod in place and tighten the key and observe whether the front end is pointing straight to the center of the wrist pin. The least deviation should be rectified by refitting the back end brasses, and if both ends are pointing exactly straight and entirely free from vertical twist, there should be no trouble with a main rod so adjusted if the proper means are taken to lubricate the bearing.

It need hardly be remarked that the back end of the main rod should have a little side play. The pernicious habit of loosening the keys and letting the hot brass run in the hope of making a bearing for itself, has the effect of spoiling the crank pin, often beyond the possibility of amendment, for while crank pins that are worn elliptically may be filed into some semblance of being true they are never perfect, but create new trouble.

Fitting the main rod in the method we have described takes time, and time is perhaps the scarcest thing there is in the average engine shop, but it will save time eventually if these hints are taken by those who may be entrusted with the fitting up of the main rod.

#### Useful Flux.

The following flux is recommended by French engineers for welding steel and iron or steel to steel. Borax ten parts, salammoniac one part, prussiate of potash one part, iron filings free from oxide or rust about one-third of a part. The mixture should be reduced to powder in a mortar. Water is added until the mixture becomes a heavy mush. It is placed on a wood fire and stirred. A material of about the appearance of pumice stone is thus produced. It is then pulverized to fine dust and is ready for use. The flux is sprinkled over the metals to be welded when they are at the welding heat.

One of the pleasantest forms of entertaining is now denied to railroad chiefs. It is no longer legal for a general manager or traffic manager or, for the matter of that, even Mr. Harriman himself, to take friends on free trips. Under the interstate commerce law if a man should accept an invitation he would have to pay his fare, just as if he were traveling in an ordinary coach. —*New York Commercial.*



RESULT OF A SHORT BRAKE PIPE.

any manner responsible for the safe handling of his train on grades should never forget.

Another thing which should always be made a rule of action, based upon knowledge of the above, by every member of a train crew, is, *never let your train get the start on you at the top of the hill*, but always ascertain whether your brakes will work properly as soon after pitching over the top as practicable. Failure to observe this precaution occasionally gets good men into trouble, and it also costs the railroad that employs such men a large sum to pay for the wrecks which too often, through overconfidence, their disregard of this important point causes.

#### Fitting the Main Rod.

It is observable that in fitting up the connecting rods of locomotives, generally speaking there is a tendency to take some

wrist pin should be tried on the brasses and it is well that the brasses should have a little clearance on the edges, both where the brasses adjoin each other as well as on the outer edges where they adjoin the walls of the crosshead. The brasses should be left open at least one-sixteenth when the rod is snugly keyed. The position of the large end of the main rod should then be carefully looked at in relation to the accuracy with which it points to the center of the main crank pin. It does not point to the center once in a hundred times. The causes that may have led to this are numerous. There is only one remedy, that is to refit the brasses on the front end of the main rod to the wrist pin. This requires fine mechanical skill and after repeated experiment the rod may be brought to the exact center of the crank pin.

When this has been done the operation must not be thought to be complete.

# Electrical Department

## K. C. & W. Electric Locomotive.

The American Locomotive Company, in conjunction with the General Electric Company, have recently completed a 50-ton electric locomotive for the Kansas City and Westport Belt Railway. The locomotive is designed for freight service and is carried on two four-wheel motor trucks of the equalized type, with a total wheel base of 22 ft., and a rigid wheel base of 6 ft. 6 ins. Each truck is equipped with two General Electric Company's type 55-II, direct current motors. The motors are inside hung, half the weight being carried on the axle and half by what is called nose suspension from the truck frame. The rated maximum tractive effort is 16,400 lbs. When exerting its rated draw-bar pull, the motors will taken a current of 160 amperes per motor and will operate a train of 320 tons on a 2 per cent. grade, at approximately 8 miles per hour.

With a current of 215 amperes per motor, the locomotive will exert a maximum instantaneous effort for starting purposes of 25,000 lbs., and will haul the same weight of train on the level at a speed of 13 miles per hour. The maximum tractive effort corresponds very closely with calculated tractive effort of a steam locomotive and the rated tractive effort is similar to that of a steam locomotive when notched up. This locomotive is provided with type M. single unit control, with 5 steps in series and 5 in parallel. It is equipped with General Electric Company's combined automatic and straight air brakes, operated by one centrifugal pump, with a piston displacement of 50 cu. ft. per minute when delivering at a pressure of 90 lbs. It is fitted with one U. S. trolley, suitable for collecting a current of 500 volts. The frame is made of 10 in. channels with cast iron bumpers and floor plates of 3/4-in. steel. The cab is of the ordinary type used on electric locomotives with one main motorman's cab and two spaces for resistance coils, air pump, etc. Some of the principal dimensions are as follows: Length over all, 31 ft. 1 in.; height over cab, 11 ft. 9 ins.; width over all, 9 ft. 6 1/2 ins.; total wheel base, 22 ft.; rigid wheel base, 6 ft. 6 ins.; driving wheels, 36 ins. in diameter.

### Electrical Units.

By ROGER ATKINSON.

When a mass of material which we call a pound is weighed at the sea level in the latitude of Washington, the force of gravity which pulls it down is also called a pound, but in this case it is a pound of force, and if we let

the pound of material fall, the pound of force will, at the end of one second, have given it a velocity of 32.16 feet per second. Since the force of gravity decreases as the square of the distance increases, if the pound of material were taken 4,000 miles high, being then twice the radius of the earth from its centre, the force of gravity would be only 1/4 of what it is at the surface of the earth, and therefore the pull of gravity upon the pound of material would only be 1/4 lb., and if the mass of material were allowed to fall under the influence of that force, it would only attain, at the end of one second, a speed of  $\frac{32.16}{2} = 8.04$  feet per second. Vice versa, if you wish to know how far to remove the weight in order to produce a given reduction in force, we have to take the square

gram the force would be 1/4 th of a gram or one dyne, which is the amount of force used as the basis of all electrical calculations. As this unit is very small, too small for most purposes, like attempting to sell coal by the grain of weight, it is multiplied by 100,000,000 and called a volt. Thus if we multiply 1/4 th of a gram by 100,000,000 we get 101936.8 grams or 101.9368 kilograms, and (1 kilo = 2.2046 lbs.) therefore = 224.7298 lbs., or the mechanical equivalent of 1 volt = 224.73 lbs

### Elementary Principles of Dynamos

By CLARENCE RENS-HAW.

All dynamos and motors depend upon the fact that if an electrical conductor is properly moved in the neighborhood



FIFTY-TON K. C. & W. ELECTRIC LOCOMOTIVE

root of the multiple of the distance. Thus, if we wish to reduce the force 9 times we remove the weight to 3 times the distance. Any other weight of material than one pound would attain the same speed under the same conditions, because the force of gravity acts upon every particle, therefore a "gram" would attain the same speed as a pound of material. Now as 32.16 feet is almost exactly equal to 981 centimeters (and is allowed to be so for electrical work) then if any piece of material is taken to a distance from the earth equal to the square root of 981 times the earth's radius, that is,  $\sqrt{981} \times 4,000$  or  $31.32 \times 4,000 = 125,280$ , it would be 125,280 miles from the centre, or 121,280 miles from the surface of the earth; then the pull of gravity upon a piece of material let fall would in one second give it a speed of one centimeter per second. The force pulling would then be 1/981 th part of the weight. Now if the weight was one

of a magnet, an electromotive force will be generated and if the circuit is closed an electric current will flow

The space between the poles of a magnet is said to be filled by lines of magnetic force extending from the north to the south pole. If a wire is moved through this space so as to cross, or cut these lines of force, an electromotive force (commonly abbreviated e. m. f.) will be generated in the wire and if the two ends of the moving wire are joined together by a second wire, an electric current will flow through the circuit thus formed. The direction of the e. m. f. is so related to the direction of the lines of force and the motion of the wire that if the thumb, forefinger and middle finger of the right hand are held as nearly as possible at right angles to each other, and if the forefinger indicates the direction of the lines of force, and the thumb, the motion of the wire, then the

middle finger will indicate the direction of the e. m. f. generated and of the current which flows when the ends of the moving wire are joined.

The value of the e. m. f. generated depends on the strength of the magnet and on the speed with which the wire is moved, that is, upon the total number of lines of force cut in a unit of time.

If the ends of the moving wire are joined so that a current flows, a greater effort is required to move the wire than before. On the other hand, if a current from an outside source is sent through the wire while it is lying in such a position as to cut the lines of force, then the wire will tend to move and the application of force will be necessary to prevent its motion. In this case, the relation of the current, the lines of force and the motion produced may be found by the use of the thumb, forefinger and middle finger of the left

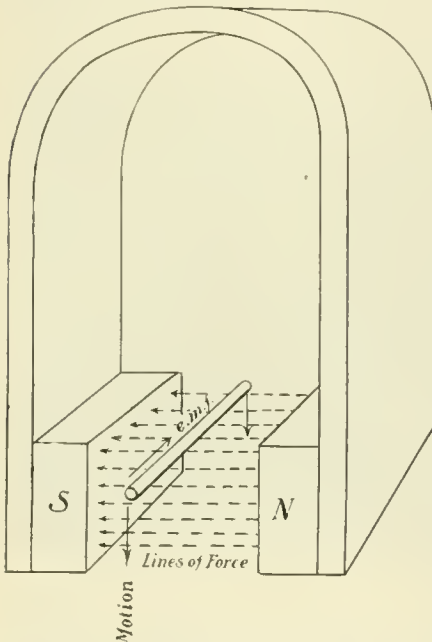

FIG. 1. THEORETICAL DIAGRAM OF A DYNAMO.

hand. If these are held at right angles, and the forefinger indicates the direction of the lines of force, and the middle finger that of the current, then the thumb will indicate the direction in which the wire will move.

In the first case where the wire is moved by mechanical force and electrical energy is generated, the action is that of a *dynamo* or *generator*. In the second case where electrical energy is applied to the wire and mechanical motion produced, the action is that of a *motor*.

If instead of moving a straight wire across the field of a magnet as in Fig. 1, the wire is bent into a loop and rotated about an axis as in Fig. 2 (which is a more mechanical arrangement)

then when the wire is in the position a b c d, the same general effect will be obtained as in Fig. 1. When the wire is in the position a' b' c' d', however, it is no longer cutting the lines of force

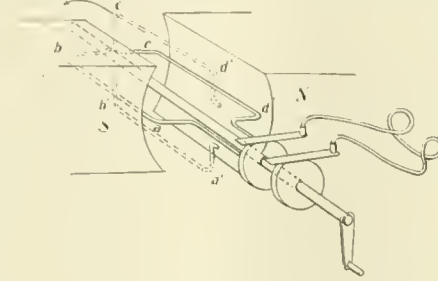

FIG. 2. GENERATOR WITH SIMPLE CONTACT RINGS.

but is moving parallel to them, so that no e. m. f. is generated. In any intermediate position, the wire is cutting lines of force but not as effectively as in the position a b c d, for the nearer it approaches the position a' b' c' d', the fewer lines it cuts for a given distance moved. As the wire approaches the position a' b' c' d' the e. m. f. generated is in one direction and as it leaves this position on the other side, the e. m. f. is in the other direction, since its motion is reversed with respect to the lines of force.

During a complete revolution therefore, the e. m. f. generated in the wire starts at zero, gradually increases to a maximum value in one direction, decreases to zero and then repeats the cycle in the other direction. An e. m. f. which varies in this way is called an "alternating" e. m. f. and a current produced by it, an alternating current. The simple arrangement indicated in Fig. 2, therefore, affords the means of transforming mechanical energy into electrical energy in the form of alternating currents and thus contains the essential elements of an *alternating current generator*.

If instead of the simple contact rings shown in Fig. 2, the ends of the revolving wire are connected to a contact device of the form shown in Fig. 3, then at the same instant that the e. m. f. generated in the wire is reversed in direction, the connection of the wire to the outside circuit is also reversed, so that the current in the outside circuit remains always in the same direction, although that in the wire itself is alternating. Such a contact device is called a "commutator" and the arrangement shown in Fig. 3 contains the essential elements of a *direct current generator*.

**To Cheapen Electric Light.**

In the days of old, before fair science roused the noble race of mankind, the making of two blades of grass grow where only one had grown before,

it was considered an ideal triumph of ingenuity and industry. We wonder what estimate would be placed upon the performance of one who had made one candle last as long as two had done before. The candle nowadays spreads its rays in the shape of electric light—but doubling its durability is a great achievement, and Professor Parker of Columbia University claims to have invented an incandescent light which has forty-five times the efficiency of the ordinary lamp with carbon filament. The novel feature of this new lamp is the filament, which is of a substance the inventor calls helion, because it resembles the spectrum of helium.

In the tests made, the lamps have burned steadily from 485 to 1,270 hours, giving an average of 1,000 hours. At a current density which will give only a dull red color to the carbon filament, the new lamp burns with a bright white light which increases in intensity as the current is increased. When the ordinary current is running the illuminating intensity is four times that of a carbon lamp, while there is said to be a much lower consumption of electricity per candle power. The lamp has the further advantage that it will carry a large overload of electricity without breaking.

Less than a year ago Dr. Siemens, a German, announced that he had made a filament of tantalum. It consumed but 1.9 watts per candle-power and was called "the most startling advance in electric lighting invention since the pioneer work of Edison." Then Dr. Kusel announced from Germany that he had found the ideal filament in tungsten, another scarce metal. It consumed 1.2 watts per candle. Now the Columbia man says that 1 watt

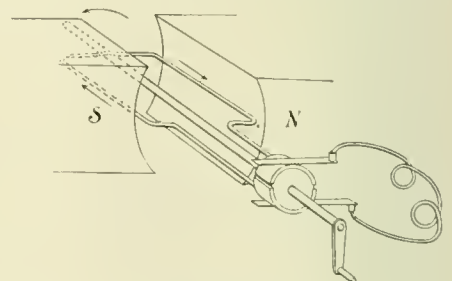

FIG. 3. SKELETON OF GENERATOR WITH COMMUTATOR.

per candle has been reached in helion, which is not a metal, and can be manufactured in unlimited quantities. If this lamp is as successful in general use as it appears in the laboratory it will be warmly appreciated by the public.

The Lehigh Valley Railroad have ordered from the Standard Steel Car Company 1,000 additional steel underframe box cars. The above-named company have completed delivery of 1,000 twin copper bottom gondola cars to that road.

### Cylinder Relief Valves.

The paper on cylinder relief valves recently read before the Canadian Railway Club was prepared by Mr. R. E. Johnson, son of the well-known assistant superintendent of motive power of the Canadian Pacific at Montreal, Mr. Lacey R. Johnson. It seems that at one of the previous meetings of this club, Mr. H. H. Vaughan, assistant to the vice-president of the C. P. R., had rallied the younger members on putting down their thoughts and observations in railway work, in the form of a paper, saying, "there is subject enough in any detail of our locomotives for a thoughtful man to write a paper on." This good natured and well timed challenge was taken up by young Mr. Johnson, who is at present fourth engineer on S. S. "Montcalm," one of the company's Atlantic fleet.

The writer of the paper supplemented his own observations on cylinder relief valves by writing to several prominent railway men on the subject. He tells us that one superintendent of motive power replied that until thus written to he had never taken time to go into the matter. Not long ago before relief valves for cylinders came to be generally used there was a great deal of trouble caused by broken cylinder heads, and the inside of cylinders was covered with grit and dirt, and the valves and seats were cut and grooved. Then the relief valve was tried. They were practically loaded spring valves, but there was no standard as regards size and they were put on in various places about cylinders and steam chests.

A case for relief valves which happened in England was cited. A heavy freight train was to be moved by a switching engine, but it could not start the train. With throttle wide open the engineer pulled the reverse lever into back gear and then threw it forward, and smash went the front cylinder cover, and when the steam cleared away, the valve rod was found to be bent just outside the steam chest. All the switching engines on the road were equipped with relief valves after that.

Some of the advantages of relief valves mentioned were: (1) that they prevent foreign substances from the smoke-box being drawn into the steam ways. (2) They prevent broken and leaky steam joints or cylinder heads by compressed condensation. (3) They make free running engines when drifting. (4) They reduce the cost of maintenance on pistons and valves. The usefulness of relief valves is greater on a rolling division than on a level one, as on the latter steam is in constant use, while on the former there

is a good deal of drifting, on down grades.

The automatic relief valve, as applied to many engines, gives trouble by the stem of the valve breaking, and allowing the valve to unseat itself, and the valve face to be injured. The combined relief and pop valve gives trouble by steam leaks, especially on the high pressure side of compound engines. This interferes with the engineer's view. This could be avoided in some cases, where space permits, by applying the improved relief valve which allows the escape of steam to the atmosphere by way of the smoke-stack.

A bit of relief valve experience was here given by Mr. Johnson. He said, "I had charge of the refrigerating plant on the 'Montcalm,' on one of her recent trips. The engines were equipped with loaded spring relief valves, one on each end of both low and high pressure cylinders. The steam pipe was about ninety feet long, which caused condensation. Under the relief valves I placed small tins to catch the water blown out. In one hour and thirty-seven minutes I had a quart of water. I then blocked up the relief valves and waited a few minutes until the engines pounded and began to slow down. I set the valves free and in a few minutes everything was running shipshape. The next time we stopped the machine, I (on the quiet) had to put in two new studs in the high pressure cylinder head, because I broke two in trying to tighten up after the experiment."

Mr. Johnson suggested the advisability of having some experiments conducted with a view of establishing some rule for proportioning relief valves to size of cylinders. An experiment in this direction which he thought might be useful would be to have a connection or electric contact between relief valve and a bell in the locomotive cab, so that when the valve lifts, the bell in the cab will ring. When this happens a note of the position of every lever in the cab to be taken, special attention being paid to reduction of train line pressure and air reservoir pressure used in bringing the trains to a stop. Next block the relief valves shut, and repeat the experiment, noting the difference in momentum of train while drifting into a station, and also take indicator cards of engine with relief valves open and closed.

### Fireproof Smoke Jack.

Mr. F. P. Gutelius, assistant chief engineer of the Canadian Pacific Railway at Montreal, has recently designed a smoke jack for engine houses, made with supporting posts and hardened asbestic

plates fastened to them. The special construction adopted is shown in our illustration. This is the standard of the Canadian Pacific Railway, its special feature being the ventilation of that portion of the house above the bottom of the hood.

The jack is made so that the smoke pipe extends up into the pipe which stands on the roof and there is an air space between the two. The ventilating arrangement is something like the construction of an injector where the smoke pipe is analogous to the steam nozzle and the outer pipe is like the combining tube.

The frame work of the jack is of wood, iron and asbestos angles. The plates are fastened by copper rivets, bolts and nails. All the material used is waterproof and

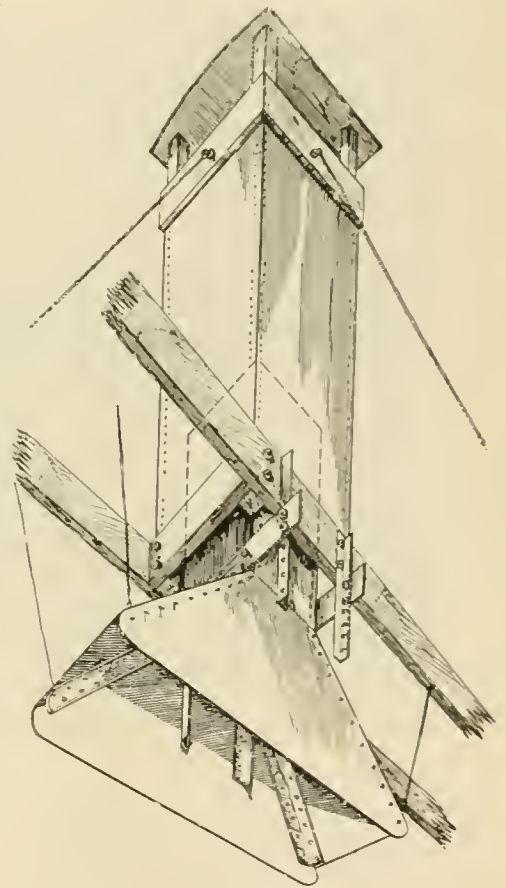

FIREPROOF SMOKE JACK USED ON THE  
C. P. R.

fireproof, it is not affected by smoke or fumes of gas or by climatic changes in temperature, etc.; it is claimed that the jack has a long life, and that its light weight and low cost recommend it for general use. The oblong aperture at the base of the funnel makes the placing of engines under it very convenient. An engine can be moved a short distance forward or back under the jack as occasion demands without smoking up the whole house. Suitable drip troughs can be placed round the edges of the funnel. The device is patented and is handled in the United States by Wendell & MacDuffie of New York.

### Automatic Switch Closer.

Among the safety devices on view at the Safety Appliance Exhibition in New York last month was one which was designed to automatically close a facing point switch in front of a moving train in case such switch had been left open through carelessness, design or other reason. Our illustration shows the device being tried on the L. S. & M. S. near Silver Creek, N. Y.

The device consists of a trip by the side of the track which engages with a striker on the side of the pilot of the engine. This striker is arranged so that the engine can back over the trip without moving it. It is in fact like the tool holder on a shaper or planer which holds

the engine is moved past the trip before the switch is thrown. The idea is to prevent a train moving at high speed from entering a switch, and the fact that the switch is automatically closed in front of a train so as to make the main line continuous does not break or any part of the switch mechanism. Mr. Ernest F. Green, the inventor of the device, was in charge of the exhibit. Our illustration shows the trip on one track closing switch on another. This was done in the test as a matter of precaution.

### Bucknell Doesn't Want Much.

Bucknell runs an engine on a branch line, and you know how a man who has all his spare time at home at the far



TESTING SWITCH CLOSING DEVICE ON THE L. S. & M. S. TRIP ON ONE TRACK CLOSES SWITCH ON ANOTHER TRACK, FOR EXPERIMENTAL PURPOSES.

against the stroke but gives easily as the tool slides back. The trip beside the track is fastened to a rod which is carried to the switch mechanism.

When the switch is opened a coil spring lying between the ties is compressed and the spring is so held while the switch is open by a locking device lying parallel with the ties in a cast iron box just outside the rails. When the trip is moved by the striker on the pilot it releases the lock and the compressed spring between the ties closes the switch at once, and before the oncoming locomotive has got up to the switch. The switch is opened and closed by hand in the usual way, and the lock contained in the box is only operated by the trip. The switch can be locked by padlock on the switch stand like other switches, but whether locked at the stand or not, the trip always operates to close the switch when it is struck. When it is desired to take the siding

end of the branch and away from the round house expects the hard working staff at that point to drop everything and attend to him for the few hours he is at the round house. Bucknell was one of this class of man, and Bucknell was regarded as a kicker.

He said something the other day to Osborne White, the round house foreman, which sounded all right for the moment. They had been talking of the amount of work which had to be done and the short time there was to do it in and Bucknell said, "I believe you foremen ought to be better paid." "I am very glad to hear an experienced man like you say that Bucknell," replied White with a smile of pleasure, "more pay would be acceptable." "Yes," replied the branch engineer, "the company ought really pay a foreman more money, because then we would get a better class of men."

### First Train Dispatcher.

The story of the first railroad train dispatcher, as given by Mr. George J. Charlton, general passenger agent of the Chicago & Alton, is briefly as follows:

"Mr. A. H. Copeland, who for nearly thirty years was agent for the Chicago & Alton Railway at Chenoa, Illinois, claims to be the first man who ever dispatched a train by telegraphic train orders.

"In the winter of 1852 Mr. Copeland worked in the post office at Middlebury, Vermont, and was also telegraph operator, the telegraph offices in those days being generally located in the post offices and not in depots. Railways had no telegraph service of their own; the trains were operated wholly by time card rules, which provided that one train would wait at a certain station until the other train had passed. Such a condition existed on the winter morning in February, 1852. The north-bound train, due to meet the south-bound train at Middlebury, was in a snowbank in the Green Mountains south of Rutland.

The conductor of the southbound train was of course unaware of this, and only knew that he and his passengers had before them a wait at Middlebury anywhere from twelve minutes to twelve hours, when at the expiration of the latter time his train regained its right to proceed south to Rutland. As the length of delay increased, the restless, irritated passengers grew bold and wandered uptown from the depot. Some of them straggled into the post office and happened to tell Copeland of the delay. The operator thought a moment. Then he said, 'You bring the conductor up here and perhaps we can fix it so that you can go on to Rutland without waiting for the north-bound train.' The conductor demurred, but finally acceded to the demand of his irate passengers.

Upon arrival at the post office Mr. Copeland handed him a message from his superintendent at Rutland. It read something like this: "North-bound train in snowbank south of here. You come on to Rutland and I will not let any train go north until you arrive.' The conductor read his order, looked Copeland straight in the eyes and said, 'I am afraid to do this. I might be taking a chance. How do I know it's genuine?' Copeland quietly replied, 'I'll ride on the engine to Rutland.' That settled it and the train went on its way, the passengers rejoicing and heartily thanking the operator, who kept up a wonderful amount of thinking while quietly sitting in the cab from Middlebury to Rutland.

"It was not until 1868, or sixteen years after all this, that Copeland went to the Chicago & Alton, where he found in full effect the perfected result of his original and accidental use of the telegraph in the movement of railway trains."

# Of Personal Interest

Mr. Y. Vandenburg has been elected president of the Birmingham & Atlantic, with office at New York City.

Mr. D. P. Kellogg has been appointed master mechanic of the Southern Pacific, with office at Los Angeles, Cal.

Mr. T. F. Carberry has been appointed division master mechanic of the Missouri Pacific, with headquarters at St. Louis, Mo.

Mr. C. F. Larson has been appointed purchasing agent of the Mississippi Central, with headquarters at Hattiesburg, Miss.

Mr. William Henry has been appointed assistant master mechanic of the St. Louis & San Francisco, with office at Memphis, Tenn.

Mr. Isaac McKeever has been appointed master mechanic of the Lehigh Valley at Weatherly, Pa., vice Mr. Thomas Coyle, deceased.

The office of Mr. W. F. Teat, master mechanic of the Louisville & Nashville, has been removed from Blue Ridge, Ga., to Etowah, Tenn.

Mr. Otto Cornelison has been appointed superintendent of transportation of the Chicago Great Western, with headquarters at St. Paul, Minn.

Mr. L. H. Wheaton has been appointed engineer of maintenance of way of the Halifax & Southwestern, with office at Bridgewater, N. S.

Mr. C. W. Clark has been appointed general foreman of the mechanical department of the Midland Valley, with headquarters at Muskogee, I. T.

Mr. L. A. Litterer has been appointed road foreman of engines of the Atchison, Topeka & Santa Fe Coast Lines, with headquarters at Needles, Cal.

Mr. J. T. Johnston has been appointed assistant general boiler inspector of the Atchison, Topeka & Santa Fe, with headquarters at Albuquerque, N. M.

Mr. Walter Reid has been appointed road foreman of engines of the second district of the Atchison, Topeka & Santa Fe, with headquarters at Needles, Cal.

Mr. C. M. Hunt has been appointed superintendent of maintenance and transportation of the Pacific & Idaho Northern, with headquarters at Weiser, Idaho.

Mr. L. H. Nolan has been appointed to the new office of superintendent of terminals of the Grand Trunk, with headquarters at Milwaukee Junction, Mich.

Mr. R. G. Long has been appointed division master mechanic of the Missouri Pacific, with headquarters at Fort Scott, Kan., vice Mr. W. C. Walsh, resigned.

Mr. O. R. Hale has been appointed master mechanic of the Torreon division

of the Mexican Central, with headquarters at Torren, Coah. Mex., vice Mr. R. H. Rutherford, transferred.

Mr. J. J. Curtis has been appointed master mechanic of the Chicago Union Transfer Railway, with headquarters at Clearing, Ill., vice Mr. D. Anderson, resigned.

Mr. N. Greener, heretofore master mechanic of the Tremont & Gulf, has been appointed superintendent of motive power of the same road, with office at Tremont, La.

Mr. R. M. Galbraith has been appointed superintendent of machinery of the Kansas City Southern, with office at Pittsburgh, Kan., vice Mr. F. Mertsheimer, resigned.

Mr. James Kennedy, who has for the past two years been on the editorial staff of RAILWAY AND LOCOMOTIVE ENGINEERING and of *The Automobile Magazine*, and



JAMES KENNEDY.

who is well known to our readers, has recently been elected vice-president of the Angus Sinclair Company of New York.

Mr. R. H. Rutherford has been appointed master mechanic of the Aquasealientes division of the Mexican Central, with headquarters at Aquasealientes, Mexico.

Mr. William McMasters has been appointed assistant purchasing agent of the Chicago, Indiana & Southern and the Indiana Harbor, with headquarters at Chicago, Ill.

Mr. J. R. Bancroft has been appointed general foreman of shops of the Houston & Texas Central, with headquarters at Houston, Tex., vice Mr. D. E. Bloxson, resigned.

Mr. G. J. De Vilbiss, formerly master mechanic of the Baltimore & Ohio at Newark, Ohio, has been appointed super-

intendent of motive power of the Hocking Valley, Toledo & Ohio Central, the Kana-wha & Michigan, and the Zanesville & Western, with headquarters at Columbus, O.

Mr. W. W. Thomas has been appointed master mechanic of the St. Louis & San Francisco, with headquarters at Cape Girardeau, Mo., vice Mr. Wm. Henry, transferred.

Mr. R. H. Cobb, Jr., has been appointed superintendent in charge of transportation, maintenance of way and equipment of the Tombigbee Valley, with headquarters at Fairfield, Ala.

Mr. F. S. Guinn has been appointed road foreman of engines of the first district of the Arizona Division of the Atchison, Topeka & Santa Fe, with headquarters at Needles, Cal.

Mr. M. P. Shields has been appointed mechanical foreman of the Intercolonial Railway, with headquarters at Chaudiere Junction, Que., vice Mr. M. Henchey, assigned to other duties.

Mr. H. C. Fleming has been appointed road foreman of engines of the Alabama Great Southern, with headquarters at Birmingham, Ala., vice Mr. S. C. Parker, assigned to other duties.

Mr. F. B. Harriman, general superintendent of the Illinois Central lines north of the Ohio River, has been appointed general manager of that road with headquarters at Chicago, Ill.

Mr. F. R. Cooper, formerly master mechanic on the Lehigh Valley, has been appointed superintendent of motive power of the South Buffalo Railway, with headquarters at Buffalo, N. Y.

Mr. M. J. McGaw, heretofore division master mechanic of the Missouri Pacific at St. Louis, Mo., has been transferred to Sedalia, Mo., in the same capacity, vice Mr. S. M. Dolan, resigned.

Mr. T. Rumney, heretofore assistant mechanical superintendent of the Erie, has been appointed mechanical superintendent at Meadville, Pa., vice Mr. George W. Wildin, resigned.

Mr. R. M. Drake has been appointed engineer of maintenance of way of the northern district of the Southern Pacific, with headquarters at San Francisco, Cal., vice Mr. W. C. Edes, resigned.

Mr. F. S. Forest, superintendent of the Montana Central, has been appointed assistant general superintendent of the Great Northern, with headquarters at Minot, N. Dak., vice Mr. J. M. Davis, resigned.

Mr. M. N. Forney, the distinguished engineer and author, has lately gone through a severe attack of illness, but is now convalescent. In reply to a request

for his photograph, Mr. Forney wrote: "My friends say I am looking better, but not better looking."

Mr. C. W. Booth has been appointed purchasing agent of the Wisconsin Central, with headquarters at Milwaukee, Wis. Mr. Booth was heretofore assistant general superintendent of that road.

Mr. H. A. Boomer, heretofore general superintendent of the Lake Erie & Western and the Northern Ohio, has been appointed general superintendent of these roads, with headquarters at Indianapolis, Ind.

Mr. H. M. Fickinger has been appointed assistant general manager of the Cuba Eastern Railroad and allied companies,

with headquarters at Fort Worth, Tex.

Mr. E. A. Westcott, heretofore foreman of car repairs on the Erie at Kent, O., has been appointed assistant mechanical superintendent in charge of the car department of the Erie, with headquarters at Meadville, Pa.

Mr. Harrington Emerson, who as an expert production engineer has for three years past been working upon the Santa Fe, recently addressed the Engineering Assembly of Purdue University on "Railroad Operating Records."

Mr. W. A. Drake, heretofore general superintendent and chief engineer of the Santa Fe, Prescott & Phoenix, has been

has for the past two years been assistant to the president of that company.

Mr. S. S. Stiffey has been appointed to the new office of general superintendent of motive power of the Hocking Valley, Toledo & Ohio Central, the Kanawha & Michigan, and of the Zanesville & Western, with office at Columbus, Ohio.

Mr. Garrett Davis, formerly district engineer on the Rock Island, has been appointed superintendent of the division of that road from Vinton to Estherville and Cedar Rapids to Minneapolis. Mr. Davis' headquarters are in Cedar Rapids, Ia.

Mr. K. A. Froberg, formerly superintendent of shops on the Great Northern, has been appointed master mechanic of

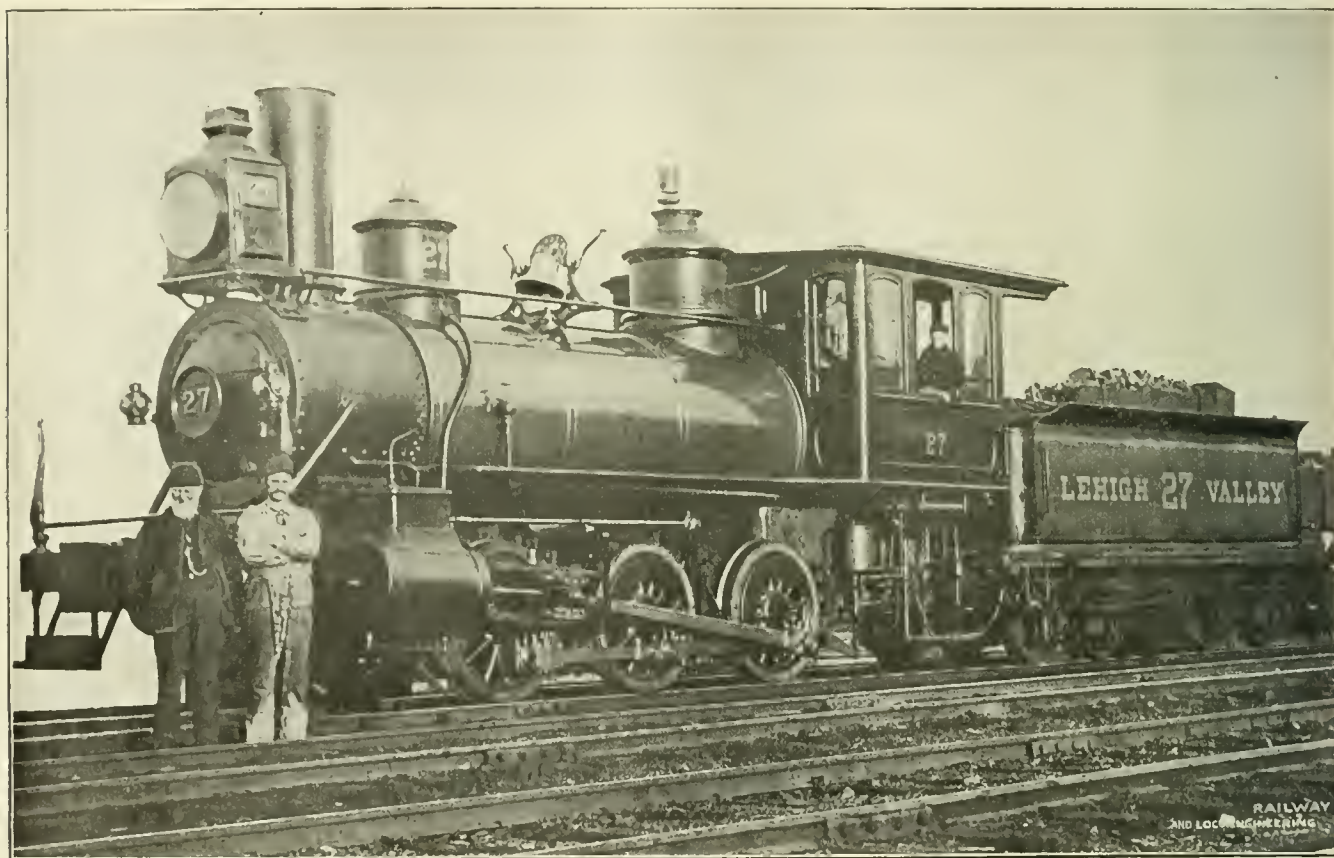

JASPER WANDLE'S LAST ENGINE. HE IS STANDING WITH HIS FIREMAN AT THE FRONT END. HIS NEPHEW, F. W. BLAUVELT, IS IN THE CAB WINDOW.

and assistant to the president of the Cuba Eastern, with headquarters at Guantanamo, Cuba.

Mr. A. H. Hodges, formerly general foreman of the Baltimore & Ohio at Brunswick, Md., has been appointed master mechanic of the Cumberland division of that road, with headquarters at Cumberland, Md.

Mr. A. E. Mitchell, formerly connected with the motive power department of the Lehigh Valley, has been appointed engineer in tests of the New York, New Haven & Hartford, with headquarters at New Haven, Conn.

Mr. J. W. Robins has been appointed general superintendent of the southern district of the Rock Island lines, comprising the Oklahoma Panhandle and Fort

appointed vice-president and assistant general manager of that road, with headquarters at Prescott, Ariz.

Mr. J. Kirkpatrick, heretofore master mechanic of the Cumberland division of the Baltimore & Ohio, has been appointed master mechanic of the Newark division, with headquarters at Newark, Ohio, vice Mr. G. J. De Vilbiss, resigned.

Mr. E. H. Harlow, master mechanic of the Valley Division of the Atchison, Topeka & Santa Fe at Richmond, Cal., has been transferred to the first district of the Albuquerque Division, with headquarters at Albuquerque, N. M.

The Standard Coupler Company, 160 Broadway, New York, announce the promotion of Mr. Edmund H. Walker to be their general sales manager. Mr. Walker

the Montana Division of that road, with headquarters at Havre, Mont., vice Mr. Geo. Herren, assigned to other duties.

Mr. H. H. Hale, formerly assistant master mechanic, Pere Marquette Railroad, Grand Rapids, Mich., has resigned to accept a position as superintendent of motive power and machinery of the Nevada Railroad and consulting engineer of the Nevada Consolidated Mining and Milling Company.

Mr. Alfred Price has been appointed general superintendent of the Central Division of the Canadian Pacific Railway at Winnipeg, Man., vice Mr. G. J. Bury, promoted. Mr. Price was at one time a telegraph operator on the road and has also been a divisional chief train dispatcher. He has made a thoroughly good



record in the various positions he has held, and has been steadily advanced in the service of the company. Mr. Price is a practical railroad man, and each step in his advancement has been gained by hard work and ability.

Mr. K. C. Spatz has resigned from the position of general foreman of the Edgemont shops of the C., B. & Q.

Mr. W. D. Dawson has been appointed general foreman of the Chicago, Burlington & Quincy shops at Edgemont, S. D., vice Mr. K. C. Spatz, resigned.

Mr. William Schlafge, formerly Master Car Builder of the Erie, has been appointed general master mechanic of that road, with headquarters at Meadville, Pa.

Mr. J. W. Small, heretofore master mechanic of the Southern Pacific at Los Angeles, Cal., has been appointed superintendent of motive power of the Arizona Eastern, the Arizona & Colorado, the Cananea, Yaqui River & Pacific, the Maricopa & Phoenix and Salt River Valley, and the Gila Valley & Northern, with headquarters at Tucson, Ariz.

Mr. George J. Bury, formerly general superintendent of the Central Division of the Canadian Pacific Railway at Winnipeg, Man., has been appointed assistant general manager of the Lines West of Fort William. This is a new position which has been lately created. Mr. Bury was at one time secretary to Sir William Van Horne, and has steadily worked his way up by perseverance and ability through the positions of assistant superintendent, superintendent and general superintendent on various divisions of the C. P. R. His appointment to the position just created gives general satisfaction. His office is in Winnipeg.

Mr. M. P. Cheney, road foreman of engines for several years past at Needles, Cal., has recently been transferred to San Bernardino as road foreman of engines of the Los Angeles Division. The engineers and firemen of the Arizona Division of the Santa Fe Railway made a presentation to him as a token of their appreciation of his straightforward and honest methods of dealing with them and his kindly and painstaking manner of giving instructions, in his official capacity of road foreman of engines. They gave him the best railroad timepiece they were able to secure in Los Angeles, fitted in a solid gold case. The following inscription was on the watch: "Presented to M. P. Cheney, road foreman of engines, by the engineers and firemen of the Arizona Division, A., T. & S. F. Railway." The presentation was made at the dedication of the recreation building which the Santa Fe Railway have provided for the employes at Needles, Cal.

Read, not to contradict and confute, not to believe and take for granted, not to find talk and discourse, but to weigh and consider.—Bacon.

### Another Veteran Engineer Gone.

Jasper Wandle, another of those old locomotive engineers, one of the few pioneers who helped make railroading a success, and whose life was practically spent with a firm grip on the throttle of a locomotive, has passed away, he died on Wednesday, January 30, 1907, at Paterson, N. J., where, for the last eleven years he has made his home with his sister, Mrs. Peter Doremus.

Mr. Wandle was born in New York City on March 10, 1825, and was nearly 82 years old. While still a young man he engaged himself with a "whaler," and for three years cruised about the Pacific Ocean and the China Sea, this was in the forties, when the American-built clipper ships and whalers were the

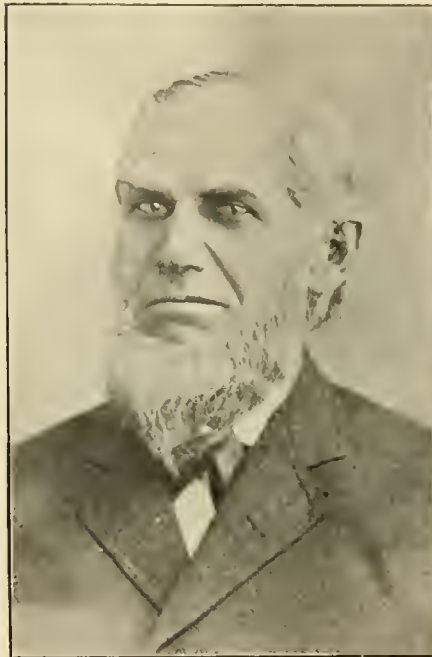

THE LATE JASPER WANDLE.

pride of the seas. In 1852 he took to railroading and began his career on the Erie Railroad, when its Eastern terminus was at Piermont, New York, he was at first employed as a fireman, but was soon promoted to the right hand side of the cab, his first engine was the "New York," No. 9, a six-wheel connected Baldwin wood burner with a haystack boiler and an old-fashioned broad top smoke stack, the valves were operated by hook motion, the cylinders were mounted at an angle about half way up the sides of the smokebox, and the main connections were on the rear drivers, there were no truck wheels under the engine.

In 1856 Mr. Wandle left the Erie, and soon after went to the Central Railroad Company of New Jersey, where for more than six years he ran both freight and passenger trains, then early in 1863 he entered the service of

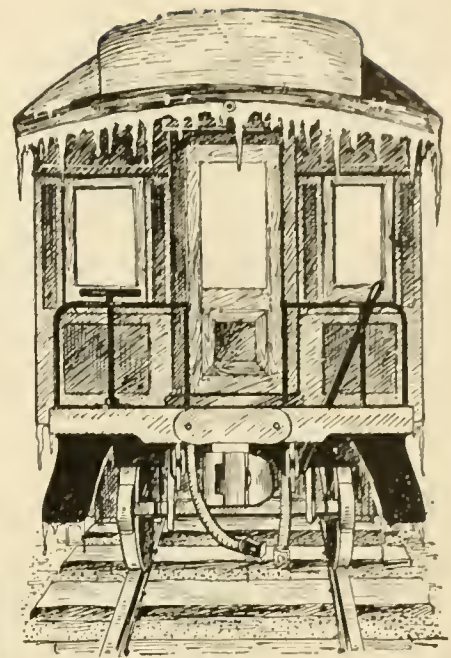

## The Cold Test

With the bleak, cold weather comes more or less imperfect action of the air brakes, and worry and trouble for the engineer as a result. If nothing is done to relieve this condition, you will be bothered all winter, and consequences may be serious.

When the air brake system is lubricated with Dixon's Graphite Air Brake and Triple Valve Grease the brakes respond sensitively to all reductions of pressure. Even in the coldest winter weather this grease will not stiffen and result in emergency action of the brakes when service application is wanted.

Get "proof" sample No. 69-I and make some trial tests on your engineer's valve and angle cocks.

**JOSEPH DIXON  
CRUCIBLE CO.  
Jersey City, N. J.**

the Lehigh Valley Railroad Company, remaining in their employ until December, 1895, over thirty-two years, when, being nearly seventy-one years of age, he was retired by that company and his name was placed upon its pension roll, thus ending most satisfactorily a long and successful railroad career; his last engine on the Lehigh Valley was No. 27, shown in our illustration on page 132.

During his later years Mr. Wandle led a very quiet life, but was always ready to talk of the good old days in railroading, his record of over forty years as a locomotive engineer was remarkable in that during all that long period of service he never met with a serious accident, this was his one pride and of which he often spoke during the latter part of his life, that this excellent record was appreciated by the Lehigh Valley Company, is shown in the following letter sent him by the superintendent notifying him of his retirement.

#### LEHIGH VALLEY RAILROAD.

Lehigh Division and Easton & Amboy Railroad, Office of the Superintendent.

EASTON, Pa., November 6, 1895.

Mr. Jasper Wandle, Engineman,  
South Easton, Pa.

Dear Sir.—In consideration of your long term of service in the employ of this company as a locomotive engineman, and your good record during that time, permission has been given to allow you to retire from active duty, and the salary to be paid you will be \$35.00 per month.

This retirement may go in effect, say by December 1st, if you so desire. Of course, if you prefer to remain at your post for a while longer, you are at liberty to do so, but considering the fact that you have been on an engine for a period of thirty-two years in the employ of this company, no doubt you will be glad to accept of retirement.

Yours truly,

(Signed) JAMES DONNELLY,  
Superintendent.

On March 25, 1851, Mr. Wandle was married at Keyport, N. J., to Miss Sarah Cornelia Allaire, a descendent of the old Huguenot family of that name, his wife died in October, 1895, they had no children, he is survived by three sisters. The body was laid to rest in the family plot in Easton Cemetery.

#### N. Y. C. Electric Locomotive.

The Coming of the Electric Locomotive on the New York Central Lines, is an interesting illustrated pamphlet of eight pages, concisely and carefully written, which describes the new motive power on the Hudson and Harlem Divisions of the New York Central. The adoption of electricity for the motive power by the New York Central, for their enormous passenger traffic into and out of the terminus at the Grand Central Station, New York, marks an era in passenger transportation in America. A few days ago there were eighty-four trains being

operated in and out of this station either by electric locomotives or multiple unit controlled electric cars. A copy of this pamphlet will be sent free to any address in the world on receipt of a two-cent stamp by George H. Daniels, Manager, General Advertising Department, Grand Central Station, New York.

#### Coal of the World.

The amount of coal which is mined in the various countries of the world only lacks about three-quarters of a million of being one full billion tons. Taking a ton of coal as occupying 40 cubic feet, the pile which the amount of the world's coal output for 1905, would make a cubic pile more than 3-5ths of a mile wide, long and high. The comparative figures as given by *Technical Literature* are as follows:

"The latest statistics available of the coal production of the world in 1905 put the total at 929,623,000 tons, as compared with 867,021,000 tons in 1904,



RECESSIONAL.

or an increase of 7¼ per cent. Most of the producing countries share in the advance, the notable exceptions being Belgium and Russia. The greatest gain was exhibited by the United States, whose output has jumped from 318,276,000 to 352,694,000 tons, or a rise of 6¼ per cent. America is now by far the largest producer, though the United Kingdom is a close second and still remains the largest exporter. The production of the United Kingdom, according to British official figures, was 239,889,000, as against 236,147,000 tons, or an advance of 1½ per cent. Germany, the third largest producer, mined 173,664,000 tons, as against 169,448,000 tons, or a gain of 2½ per cent. The output of India increased from 7,682,000 to 7,921,000 tons, and of Japan from 11,600,000 to 11,895,000 tons. Austria-Hungary's total is 40,725,000, as compared with 40,335,000 tons, and France's contribution is 36,048,000, as against 34,502,000 tons. The yield of Canada has grown from 6,814,000 to 7,959,000 tons, and of South

# GOLD Car Heating and Lighting Co.

Manufacturers of

ELECTRIC,  
STEAM AND  
HOT WATER  
APPARATUS  
FOR RAILWAY CARS

EDISON  
STORAGE  
BATTERY  
FOR RAILWAY CAR  
LIGHTING

Largest Manufacturers in the World  
of Car Heating Apparatus

Catalogues and Circulars  
cheerfully furnished

Main Office, Whitehall Building  
17 BATTERY PLACE  
NEW YORK

America from 3,015,000 to 3,210,000 tons, and France's contribution is 36,320,000 tons. The production of America from 3,015,000 to 3,219,000 to 21,844,000 tons, and of Russia from 19,318,000 to 17,120,000 tons, reasons for the latter being obvious."

A pamphlet just issued by the American Locomotive Company illustrates and describes ten-wheel locomotives weighing over 150,000 lbs. It is a sequel to the pamphlet issued last month by the same company describing lighter designs of this type. Thirty different designs are illustrated and the principal dimensions of each design is given. The engines presented in the pamphlet range in weight from 152,000 to 201,000 lbs., and are adapted to a wide variety of road and service conditions. This is the sixth of the series of pamphlets which is being issued by this company, and the series now includes pamphlets on the Atlantic, Pacific, Consolidation and Ten-Wheel types of locomotives. A copy of this booklet, which is standard with other American Locomotive publications can be had by direct application to the head office, which is at 111 Broadway, New York.

**Fire at Baldwin's.**

Last month a fire occurred at the Baldwin Locomotive Works in Philadelphia. The building destroyed faced on Spring Garden street and adjoined the main offices. The burned building was about 175 ft. long by 150 ft. deep, and in it sheet iron work, pipe bending, brass fitting, painting of cabs was done, also the paint store, metal pattern store and part of the drawing office were in the same building. About a thousand men were temporarily thrown out of employment, but have since been absorbed into other departments. The loss has been estimated at about \$500,000. The building will be restored as quickly as possible.

**How and Why.**

It is well to bear in mind that the man who only knows how to do certain things, but does not know why they are done, usually remains in a subordinate position. It is essential to success that you get into the habit of analyzing things.

This is particularly true in regard to railway men. The thinking man comes to the surface. Some reading outside of the daily routine work should be done by all who expect to advance in their calling.

Right here, RAILWAY AND LOCOMOTIVE ENGINEERING supplies the necessary material. Its pages are filled with the expressions of the best thoughts of the leading railroad men of our time. It has met the universal approval of the

leading railway men throughout the world. The price, \$2.00 a year, places it within the reach of every railroad employee.

"Twentieth Century Locomotives," Angus Sinclair Co., deals comprehensively with the design, construction, repairing and operating locomotives and railway machinery. First principles are explained. Steam and motive power is dealt with; workshop operations described, valve motion, care and management of locomotive boilers, operating locomotives, road repairs to engines, blows, pounds in simple and compound engines; how to calculate power, train resistance, resistances on grades, etc. Shop tools explained. Shop recipes, definitions of technical terms, tables, etc. Descriptions and dimensions of the various types of standard locomotives. The book is well and clearly illustrated and is thoroughly up to date in all particulars, fully indexed. Price, \$3.00.

"Locomotive Engine Running and



USING STEAM.

Management," by Angus Sinclair, is an old and universal favorite. A well-known general manager remarked in a meeting of railroad men, "I attribute much of my success in life to the inspiration of that book. It was my pocket companion for years." Price, \$2.00.

"Practical Shop Talks." Colvin. This is a very helpful book, combining instruction with amusement. It is a particularly useful book to the young mechanic. It has a stimulating effect in inducing him to study his business. We sell it for 50 cents.

Spangenberg's Steam and Electrical Engineering has 672 pages, 648 illustrations. It may be called a complete library in one volume, and is in question and answer form; which is an easy way of obtaining useful information. Covers a wide field. Fully indexed for reference so that any subject may be readily turned to and answer found. Price, cloth, \$3.50.

The 1907 Air Brake Catechism, by C. B. Conger. Convenient size, 230 pages

WANTED—Engineers, Firemen, Electricians and all steam users. Do you want to be "put wise"? Send for 52-page pamphlet containing Questions asked by the different Examining Boards throughout the country. Sent FREE. GEO. A. ZELLER BOOK CO., 21 So. 4th St., St. Louis, Mo.

**Ball's Official R.R. Standard Watches**

16 AND 18 SIZE

17 and 21 Ruby Jewels, Sapphire Pollets

Ball's Improved Safety Double Roller



Are without question the finest watches that American talent and skilled labor can produce, and they are giving such universal satisfaction that we have no hesitancy in claiming that they are the best and safest railroad watch on the market. Tests severe and numerous have proven this fact to the most critical

users in all sections of the country, to which thousands of good Railroad and Brotherhood men are ready to certify.

We have an authorized agent in nearly every railroad center. Call on him for information and facts. Write us for descriptive matter.

**The Webb C. Ball Watch Co.**  
Watch Manufacturers  
Ball Building, Cleveland, Ohio, U. S. A.

**METAL PRESERVATIVE PAINTS AND PRIMER**

for locomotives, boilers, stacks, front-ends, gearing, frame-work, metal roofs, etc.

Tell us your needs.

Metal preservative paints have been our specialty for 22 years.

Paints for all conditions.

THE **STANDARD PAINT CO.**

Sole Manufacturers.

100 William St., New York

CHICAGO

ST. LOUIS

well illustrated. New edition. Up to date information concerning the whole air brake problem, including the ET equipment in question and answer form. Instructs on the operation of the Westinghouse and the New York Air Brakes, and has a list of examination questions for enginemen and trainmen. Bound only in cloth. Price, \$1.00.

"Compound Locomotives." Colvin. This book instructs a man so that he will understand the construction and operation of a compound locomotive as well as he now understands a simple engine. Tells all about running, break-downs and repairs. Convenient pocket size, bound in leather, \$1.00.

"Catechism of the Steam Plant." Hemenway. Contains information that will enable a man to take out a license to run a stationary engine. Tells about boilers, heating surface, horse power, condensers, feed water heaters, air pumps, engines, strength of boilers, testing boiler performances, etc., etc. This is only a partial list of its contents. It is in the question and answer style. 128 pages. Pocket size, 50 cents.

"Care and Management of Locomotive Boilers." Raps. This is a book that ought to be in the hands of every person who is in any way interested in keeping boilers in safe working order. Written by a foreman boilermaker. Also contains several chapters on oil burning locomotives. Price, 50 cents.

"Locomotive Link Motion." Halsey. Any person who gives a little study to this book ceases to find link motion a puzzle. Explains about valves and valve motion in plain language. Price, \$1.00.

#### Track Insulation on a Bridge

One method of carrying railroad track over a steel bridge where a track circuit is used for operating automatic signals is very well illustrated on the Delaware, Lackawanna & Western at East Buffalo, N. Y. The bridge in question carries several lines of rails over William street in that city. A similar floor is used on the Lackawanna at Hoboken, N. J., where the tracks cross Henderson street. Mr. L. Bush, chief engineer of the railroad, to whom we are indebted for the information and the drawing from which our illustration is made, informs us that the design has proved very satisfactory in practice. The bridge has been in service five years and notwithstanding the difficulty of insulating rails where they fasten direct to metal-work, the insulation has proved very effective and has not caused trouble on the signal system.

At the East Buffalo bridge it was desired to avoid raising the grade line and at the same time maintain a fixed clearance over the tracks and underneath the structure. This arrangement gives a comparatively shallow floor of good construc-

tion. Each rail is carried over the bridge in a 15-in. channel weighing 50 lbs. to the foot. In the channel space between flanges a strip of vulcanized wood 12 ins. wide and about  $\frac{3}{4}$  in. thick is laid, and on this and in the centre of the channel the rail stands. On each side of the rail pieces of oak, cut to fit flange of rail are bolted down through the holding strip of oak, the vulcanized wood, the channel web and the  $\frac{1}{2}$ -in. plate which forms the metal floor of the bridge.

The oak holding pieces fit tightly between the flanges of the channel and the web of the rail and are laid in 7 ft. 6 in. lengths. The oak pieces are thick enough to come up flush with the top of the channel flanges. In this way the rails are held rigidly down in the centre of the channels and the holding bolts do not form a metal contact between rail and the bridge floor. The track circuit for operating the electric automatic signals is therefore perfectly insulated.

The bridge floor is, as we have said, a  $\frac{1}{2}$ -inch plate, carried on a series of 24-in.

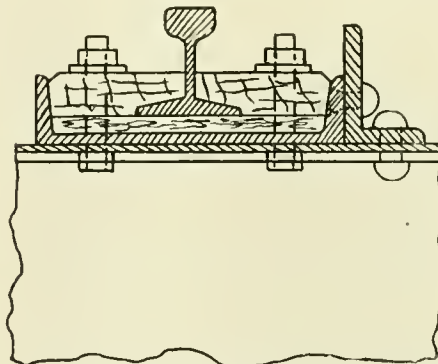

RAIL INSULATION AND GUARD ANGLE ON STEEL BRIDGE.

I-beams, and another feature of this method of rail fastening is the presence of an angle  $6 \times 4 \times \frac{3}{4}$  ins. placed with its long leg against the flange of the channel on the inner or gauge side of each rail. This angle is riveted to the floor plate and also to the adjacent flange of the channel. On the inside of the channel the rivet heads are countersunk, so that the oak holding pieces can be laid in place without being notched out for rivet heads. The angle therefore stands up to rail level and with the channel forms a very stiff and solid form of construction.

The angles, which are carried off the bridge at each end, meet on the bank in a sharp point somewhat resembling the lines of a gothic arch or church door, this outline being the usual form in which bridge guard rails terminate. The object of this angle brace is, that in case of derailment of any vehicle while on the bridge the wheels would be prevented from approaching dangerously near the edge of the structure. If off the track, the flange of the wheel would, of course, plough into the oak holding strip, but the angle would ensure a safe limit to the displacement of

## JUST PUBLISHED The Walschaert Locomotive Valve Gear

By W. W. WOOD.

Nearly 200 pages.

Fully Illustrated.

PRICE \$1.50

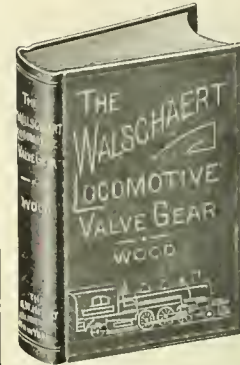

The only book issued that is devoted exclusively to the Walschaert Valve Gear, and it fills a demand which, during the last few months, has become very important. If you would thoroughly understand the Walschaert Valve Gear you should possess a copy of this book, as the author takes the plainest form of a steam engine—a stationary engine in the

rough, that will only turn its crank in one direction—and from it builds up—with the reader's help—a modern locomotive equipped with the Walschaert Valve Gear, complete.

The points discussed are clearly illustrated; two large folding plates that show the position of the valves of both inside or outside admission type, as well as the links and other parts of the gear when the crank is at nine different points in its revolution, are especially valuable in making the movement clear. These employ sliding cardboard models which are contained in a pocket in the cover.

The book is divided into four general divisions, as follows: I. Analysis of the gear. II. Designing and erecting the gear. III. Advantages of this gear. IV. Questions and answers relating to the Walschaert Valve Gear, which will be especially valuable to firemen and engineers preparing for an examination for promotion.

Just Issued—1907 Revised and Enlarged Edition.

UP-TO-DATE

## AIR BRAKE CATECHISM

By ROBERT H. BLACKALL.

PRICE \$2.00

The Standard Book on the Air Brake. Contains over 2,000 Questions and Answers giving a detailed description of all the Old Standard and Improved Equipment.

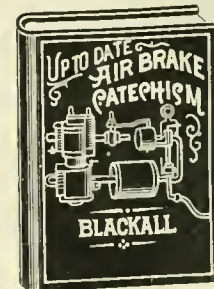

Owing to the many changes and improvements made in the Westinghouse Air Brake it has been found necessary to issue the new, revised 1907 edition of the Air Brake Catechism, which contains all the latest information necessary for a railroad man to pass his

examination on the new older style of brake.

The new revised 1907 edition is right up to date and covers fully and in detail the Schedule E. T. Locomotive Brake Equipment, H-5 Brake Valve, SF Brake Valve (Independent), SF Governor Distributing Valve, B-4 Feed Valve, B-3 Reducing Valve, Safety Valve, K Triple Valve (Quick-Service) Compound Pump.

Send for a special circular of these books as well as our Other Railroad Books. Copies of these books sent prepaid on receipt of price.

Agents Wanted Write for our special terms. You can make equal to a month's pay selling our books on the side.

The Norman W. Henley Publishing Co.  
132 Nassau St., New York, U. S. A.



## When the Employer weighs a man

Did you ever stop to think that your employer constantly weighs his men balancing one against the other?

Of two men, you and another, both equally faithful and energetic, the thing that decides in your favor or against you is training.

The untrained man kicks the beam—weighs light; the trained man outweighs him, always. He must be kept, promoted, pushed ahead.

The INTERNATIONAL CORRESPONDENCE SCHOOLS are organized to give you the training that makes you indispensable to your employer. I. C. S. training turned the scale in favor of 712 men in two months of last year, bringing them promotions or increased salaries.

Within the next few months thousands more will be advanced through I. C. S. training. Will you be one of them? You can be, without leaving your home or present work. It makes no difference where you live, what you do, or how little you earn.

Write us today, stating the occupation you would like to rise in, and we will tell you how you can advance most easily and most surely.

Facts are facts. You are being weighed every day. Don't be found wanting! Write us at once.

### Here is a List of Good Positions

Select the one you wish to secure, write a postal to the INTERNATIONAL CORRESPONDENCE SCHOOLS, Box 805, SCRANTON, PA., and ask how you can qualify to fill it at a good salary. Be sure to mention the position you prefer.

- |                      |                     |
|----------------------|---------------------|
| General Fore. R. R.  | Electrical Engineer |
| R. R. Shop Foreman   | R. R. Con. Engineer |
| R. R. Trav. Engineer | Civil Engineer      |
| R. R. Trav. Fireman  | Bridge Engineer     |
| Locomotive Engineer  | Chemist             |
| Air-Brake Instructor | Mining Engineer     |
| Air-Brake Inspector  | Architect           |
| Air-Brake Repairman  | Bookkeeper          |
| Mechanical Engineer  | Stenographer        |
| Mechanical Drafts.   | Ad Writer           |

the trucks so that vehicles, even moving at high speed, would be at least safely carried over the bridge. Satisfactory insulation with a high degree of safety has thus been secured.

### Twist Drills.

To say that the Cleveland Twist Drill Co. has brought its specialty to a high degree of perfection is not to overstate the case. Catalogue No. 34, just issued, is a model of its kind; not only are the drills and attachments described and illustrated but complete instruction is given in regard to the proper use of the drills so that any intelligent reader can readily learn to use these fine tools as they should be used. Probably one of the newest features in the catalogue is the illustrations and descriptions of the improved grip sockets which form an excellent device for holding taper shank tools. The oil feeding sockets are another important and essential feature

that the earthquakes have so disturbed that strata that the oil and coal have been dislodged from their respective places and thrown together to a certain extent. This fact has caused considerable dissatisfaction among coal consumers, who claim that the hard coal which they used to buy a few years ago for about half the present price of the product was fully twice as good as what they get to-day. The oily coal of the present day is also dusty and sooty like soft coal, and when burned in furnaces dirties up all the rooms in the house."—*Milwaukee Sentinel*

### Self-Closing Water Gauge.

At the American Museum of Natural History, in New York, there was held last month an exhibition of safety appliances, and among the devices for use on railroads was an automatic self-closing safety gauge glass mounting and we understand this appliance is being tried on the New York Central.

The device is made by the Northern

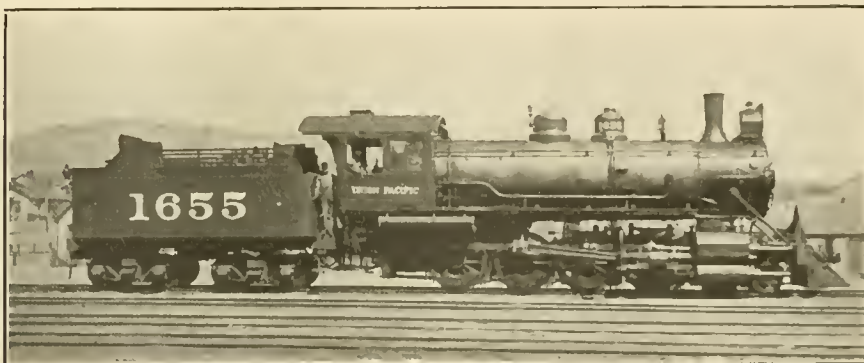

VAUCLAIN FOUR-CYLINDER COMPOUND ON THE U. P.

which only require to be seen to be appreciated. It may be remarked that while the use of twist drills has been general for many years, the Cleveland Company has strikingly emphasized the proper use of these tools so that full efficacy of the operation of the twist drill can be obtained and the life of the drill prolonged. Catalogues may be had on application to the company, Cleveland, Ohio. Catalogue No. 32 furnishes nearly 200 pages of illustrations and descriptions, while Catalogue 34 has the particular merit of presenting brief and lucid instructions.

### Oil in Coal.

"One odd feature of the seismic disturbances of the last decade is the effect they have had on coal," said Hobart Johnson, of Scranton, Pa. "All the coal mined this year has been so heavily charged with oil that it burns like pitch pine and will last only about a third as long as the old-fashioned anthracite.

"The supposition among mining experts

Specialty Company, and consists of the ordinary gauge glass mounting with the ordinary valve on the end of the threaded stem, which can be closed or opened in the usual way. In addition to this valve there is inside a weighted check valve hinged to a pivot on its lower edge. The weight of the valve normally keeps it open, but any undue rush of steam or water through the mountings, as when a gauge glass breaks, causes the valve to close and the pressure on the back of the valve holds it closed.

In order to prevent the closing of this valve when blowing out the glass, the pivot on which the hinged check valve turns is made in the form of a horizontal spindle, which passes out of the mounting through a gland and packing nut and terminates in a small hand wheel. The spindle is made with a lug which engages with a small projection on the hinged check valve, and when the spindle is turned the valve can be opened, and held open. This permits of the gauge glass being blown out as occasion requires.

The spindle, lug and hinged check valve are disposed to one another so that they cannot be put together except in one way, and that the right way, and in this respect the device is said to be fool-proof, and it is further arranged that though this hinged check valve can be opened by hand when it is desired to blow out the gauge glass, it is impossible to shut the check valve by hand. Nothing but the rush of steam and water through the mounting will close the check, and though it can be swung back temporarily to permit of blowing out, it cannot be closed from the outside.

There is one other contingency provided for in this device, and that is that in case the hinged check valve was left closed after the glass had been blown out, that it should automatically open so that a misleading or false water level would not be possible in the glass. In order to do this there is, in the seat of the hinged check valve, a small groove cut, so that even when shut, the valve is always "cracked," and a slight leakage constantly takes place. This has the effect of filling the glass in a minute or two, and when the pressure in the gauge glass equalizes, the valve falls fully open by its own weight and correct water level is obtained.

The small groove in the face of the check valve also serves another purpose. In case a gauge glass should break when no one was in attendance the hinged check valves would close and prevent loss of water and steam, but these valves being always "cracked" slightly open, by reason of the groove in the face of each would cause a constant sputter and buzz of water and steam, sufficient to call attention to the fact that the glass was broken.

#### Cui Bono?

An industrious watchmaker, in Toronto, Canada, has recently constructed a steam engine smaller than a common house fly. It weighs 4 grains, and it would require 120 such engines to weigh one ounce. The speed is said to approach six thousand revolutions per minute. The sound emitted while running resembles that made by a mosquito about to alight on a victim. The bore of the cylinder is 3-1000 of an inch; the stroke is 1-32 of an inch. The working parts are of steel. The engine bed and stand are of gold. There are seventeen pieces in the engine, and in running before the Canadian Institute compressed air was used. No motion is visible to the naked eye, but the calculations of speed made by Prof. C. A. Chant of Toronto University shows that the engine is the fastest of its size on earth. It always seems to us that there is an enormous amount of energy wasted in work like this.

#### Electric Tools.

A finely illustrated catalogue has been issued by the Chicago Pneumatic Tool Co., chiefly explanatory of the principle and workings of their air cooled Duntley electric tools. Portable pneumatic tools have for many years been recognized as an essential requisite to all machine shops claiming to be in any sense prepared to meet the requirements of the times. As is well known a compressor plant is essential to air worked tools and as there are many busy mechanical establishments where there is neither room for, nor a desire to incur the necessary expense of fitting up, a plant of this kind, the Chicago company has met the situation by designing the Duntley portable electric tools which fulfil all requirements and are adapted to any shop or factory where there is a surplus of electric energy. Thousands of the tools are now in use, and we would recommend those who may be interested in the matter to apply for a copy of the Electrical Tool Catalogue, No. 21, to the Chicago Pneumatic Tool Company.

#### Locomotive Tonnage Rating.

The first essential in properly rating engines is to determine scheme upon which to base the ratings. These were practically the opening remarks of Mr. D. C. Buell in a paper on Tonnage ratings of engines read before the Central Railroad Club not long ago. The items, he said, which determine the basis for ratings are the character of division, hilly or level, distance between terminals, length and location of ruling grades, condition of road bed, length and location of side tracks, water tanks, and coaling stations, density of traffic, character of freight to be handled and the service that must be given. To this should be added the condition of the power and facilities for making running repairs and doing boiler work at terminals.

From a mechanical department standpoint, it is sometimes uneconomical to load an engine as heavily on one division as on another, even if the grades are the same, provided the condition of the power is poor or engines cannot be properly cared for at terminals, as the chance for engine failures is greatly increased. One engine failure a day will many times more overbalance the small increase of tonnage gained by trying to handle too heavy a rating.

There are two ways to determine engine ratings: First by theoretical calculation, second by actual service tests. To get at the theoretical tonnage rating it is necessary to know the ruling grade in feet per mile or in per cent., the maximum curvature on the ruling grade, and if compensated or not, the tractive power of the

## Tate Flexible Staybolt



Strong

Effective

Economical

Flexibility

Durability

Simplicity

Holds firebox sheets securely together, and accommodates itself to the unequal expansion of the plates.

## FLANNERY BOLT COMPANY

PITTSBURG, PA., U. S. A.

Suite 308, Frick Bldg.

B. E. D. STAFFORD, - - General Manager  
Write us for Reference Book

# Homestead Valves

Straightway, Three-way and Four-way, and

# Homestead Locking Cocks

Are Famous the World Over

They cost more, but are worth very much more than other makes. You try them and see.

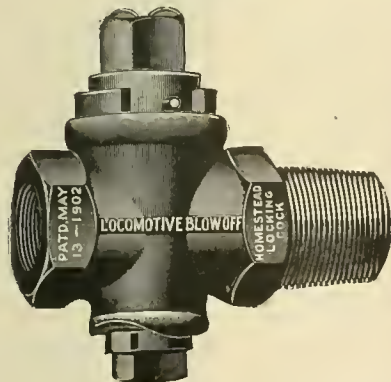

**HOMESTEAD VALVE MFG. CO.**

WORKS: **HOMESTEAD, PA.** **PITTSBURG, PA.**

## American Locomotive Sander Company

13th & Willow Sts., Philadelphia, Pa.

Proprietors and Manufacturers

LEACH, SHERBURNE, DEAN, SANDERS  
HOUSTON, "SHE" and CURTIS

**THE ROBERT W. HUNT & CO.**

Bureau of Inspection, Tests and Consultation.  
1137 THE ROOKERY, CHICAGO.

66 Broadway, New York.

Park Building, Pittsburg.

31 Norfolk House, London, Eng.

Inspection of Steel Rails, Splice Bars, Railroad Cars, Wheels, Axles, etc. **CHEMICAL LABORATORY**—Analysis of Ores, Iron, Steel, Oils, Water, etc. **PHYSICAL LABORATORY**—Test of Metals, Drop and Pulling Test of Couplers, Draw Bars, etc.

Efficiency Tests of Boilers, Engines and Locomotives.

engine and its total weight in working order. The resistances are usually stated in pounds of draw bar pull, and are figured in pounds for each foot rise per mile or 20 lbs. per ton for a one per cent. grade. For curvature the most satisfactory allowance seems to be ½ lb. per ton for each degree of curvature. The resistance of cars at from 6 to 20 miles per hour, is about 5 lbs. per ton for old equipment. For the internal friction of an engine 15 lbs. per ton with oil lubrication, and 17 lbs. per ton for grease, give satisfactory results.

Theoretical calculations based on these or similar rules generally check up very closely the results of actual tests. In order to get the best results of service tests, the use of a dynamometer car is essential. A simple dynamometer car can be constructed by strengthening the frame

trains are expected to haul under favorable conditions. It is generally too heavy for daily practice. Other ratings such as "B", 5 per cent. less than "A," also "C" and "D" ratings are made for fast trains and bad weather conditions. Rating "A" is the dead freight tonnage.

To get at a practical rating for the different hills, judgment has to be used in loading trains to a point at which the engine can just get over the grades when working full capacity and in most cases a second engine will not be necessary for a test of this kind. In these tests attention has to be paid as to how the engine has to be worked, and an estimate made as to how much less, or perhaps more, might have been in the train to give the average speed over the grade, and to cause the engine to just make the minimum speed on the hardest pulls. In case of stalling when



CANTILEVER BRIDGE ON THE A. T. & S. F., AT NEEDLES, CAL.

of an old passenger car or a caboose and installing an hydraulic dynamometer, which can be purchased for about \$250 in open market, and equipping the car with a speed recorder.

Some interesting facts, the speaker said, had been brought out by tests with a dynamometer car by Mr. C. D. Purdon, consulting engineer of the 'Frisco system, in which he has been able to show that grade reductions below .5 per cent. is uneconomical, as the tonnage which can be pulled over a grade of less than .5 per cent. is more than can be started on level track.

If it is desirable to get the maximum tonnage that an engine can haul over certain grades, the train should be made too heavy in the test for the grade, so as to be sure to stall the engine, and a second engine should follow to cut off cars and assist in the test. On some roads such a rating is called the "A" rating and is shown as the amount of dead freight

making this practical test, the speaker said the only thing to do was to go back and try it again.

It is important to have the engine in good condition, and that the crew should be able to maintain boiler pressure. Dry valves on an engine make a difference of 25 or more tons in pulling capacity on a long hill, and this is only one of several things which may affect the engine's performance. As a general proposition 10 or 15 per cent. reduction from dead freight tonnage is found to give good results, though very fast schedules require a greater reduction.

The matter of arranging for reductions due to bad weather conditions is open to argument. The Canadian Pacific make the least reduction for extremely cold weather of any road known to the speaker, and he said this fact was due to that road being well prepared for cold snaps. He believed that this matter should be handled by the chief dispatcher. Another point

touched on was that no matter how carefully ratings are made, successful results cannot be obtained if the way-bills do not show proper weight and if conductors do not accurately figure out the tonnage. It must be borne in mind that into the problem of tonnage is woven practically all of the problems of Transportation and Traffic Departments, and many of those of the mechanical department, and that arbitrary handling of the subject will cause poor service, long hours on the road, engine failures, excessive overtime, and general dissatisfaction.

#### Alundum.

The Norton Company, of Worcester, Mass., have achieved an enviable reputation in their specialty of grinding wheels. Their extensive works at Worcester, Mass., have been found insufficient to keep up with the growing demand for their machines, and an elaborate electric furnace plant for the manufacture of Alundum has been established at Niagara Falls, N. Y. As an abrasive Alundum is said to surpass any other material hitherto in use. This material possesses great hardness and is suited for the bonding of its grains into wheels, thereby securing a product which is accurate and in form homogeneous in structure. The enterprising company have just published a finely printed pamphlet descriptive of the manufacture of Alundum, and perusal of the work will repay all who are interested in grinding machinery.

#### A Child's Judgment.

A chance shot had pierced a noisy little sparrow, who fluttered and struggled, and dropped a lifeless, fluffy heap just in front of where our little four-year-old boy was standing. Quickly picking it up before his dog Rover could get it, he turned the feathery morsel over in his hand, smoothed, and tried to coax it back to life again.

Unseen by him we watched the workings of his baby face, which had become so serious that we were about to throw open the window and speak to him, when he turned and walked with childish dignity down the path, across the broad street, and up the flight of steps leading to our good friend and physician's door. We noted his up-raised hand, his pounding upon the doorway, its opening, and his passing in beyond our vision.

As soon as his familiar war-whoop and the bark of his dog were heard again, we went over to the doctor's and met him half way as he was coming to us. His kindly face had that queer look of half-amusement and whole earnestness that held us quiet, and we waited for him to speak.

"I happened to be very busy in the study," he said, "when the door quietly opened, and your little boy stood in front of me, holding out in his tiny hand a dead sparrow. 'Well,' I said, 'Wentie, what can I do for you?'"

"'Undead this sparrow,' he replied.

"'I cannot do that,' I answered.

"'Doctor, can't you dead a sparrow?'"

"'Yes, Wentie.'

"'And can't you un-dead a sparrow?'"

"'No, my little boy, I cannot.'

"'Well,' he said, as his face grew red, and his eyes very bright, 'well, Dr. Baker, I don't think you are very much of a doctor, any way!' and he turned on his heel and left me, startled and rebuked, feeling what he had said in his childish wisdom was true, and—that I wasn't much of a doctor after all."—*Robert Mitchell Floyd.*

#### Railroad Safety Lamps.

The principle of what are called the Stillman safety lamps was shown at the exhibition of safety appliances which was recently held under the auspices of the American Institute of Social Service. The Stillman hand lamp as applied to railroad work for use of conductors, brakemen and others is similar to the usual form.

The font of the lamp is provided with a perforated metal false bottom and a perforated wick chamber of cylindrical form. The rest of the space is packed with wool, leaving an open space at the bottom for free oil. The wool absorbs the oil in the font and when the lamp is lighted there are always slight drippings of oil into the shallow space at the bottom and this the wick absorbs and so feeds the flame.

If the lamp is overturned the free oil which has dripped into the shallow space in the bottom of the font is carried back through the perforations of the false bottom and is re-absorbed by the wool. This causes a partial vacuum which is at once filled by air which enters through and around the wick, thus causing a down draught sufficient to extinguish the flame.

The lamp designed for use in electrical establishments or on an electric road has a handle covered with insulating material so that in case the lamp accidentally came in contact with the third rail or a live wire the man carrying the lamp would not receive an electric shock.

#### The Past of the Pass.

The man who through the courtesy of a high railway official traveled for years all over the country wherever pleasure or his business took him on a pass carries a neat gold-edged card case, one side of which was arranged to hold his "annual." This could be seen through a piece of transparent celluloid, and handling by the conduc-

## MASTER CAR BUILDER

### IS OPEN FOR ENGAGEMENT

Young, Active, used to Big Propositions; Capable of Installing Piece Work; Steel Car Work Handled; Not Afraid of Hard Work.

Further Particulars by Addressing

**J. R. P.**

Care **ANGUS SINCLAIR CO.**

**136 Liberty Street, New York**

## THE UNION SWITCH & SIGNAL COMPANY

### CONSULTING AND MANUFACTURING SIGNAL ENGINEERS

Automatic Block Signals—Electric  
and Electro-Pneumatic

Interlocking—Electric, Electro-  
Pneumatic and Mechanical

Electric Train Staff Apparatus

General Offices and Works at  
**SWISSVALE, PA.**

#### DISTRICT OFFICES:

**NEW YORK** - - 143 Liberty Street

**CHICAGO** - - - Monadnock Block

**ST. LOUIS** - - - Frisco Building

### THE TANITE CO. seeks the support of Railroaders because:

The man who uses a TANITE wheel will find it safe. Because pay for a TANITE wheel secures the greatest productive capacity. Because TANITE MILLS EMERY is mined in America and appeals to all who earn wages in America. Because TANITE grinding machines are practical.

THE TANITE CO. sells Emery, Solid Emery Wheels, Buffing Lathes, Guide Bar Grinders, Car Brass Grinders, Bench and Column Grinders, Surfacing Machines, Open Side Emery Planers, Saw Gummers, Automatic Planer Knife Grinders, Diamond Tools, Polishing Paste for Brass and Nickel, Emery Wheel Cutters and Dressers.

*The Tanite Co. builds special machines  
for special wants*

**THE TANITE CO.  
STROUDSBURG, PA**



## Locomotive Blow-Off Plug Valves

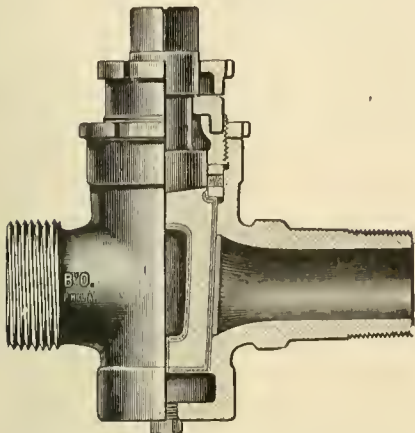
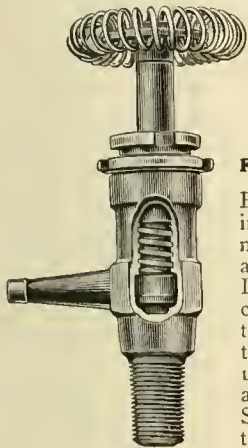

Fig. 9.

All Brass, extra heavy, with Cased Plug. For 250 lbs. pressure. Made with Draining Plug to prevent freezing.

## Locomotive Gauge Cocks

For High Pressure



Bordo Self-Grinding Gauge Cocks, made with renewable Hard Bronze Disc. Opened and closed with a quarter turn. Guaranteed Steam tight under the most exacting conditions. Shanks Threaded to specifications for Locomotives.

Fig. 23, with Wheel.

## Swing-Joints and Pipe Attachment

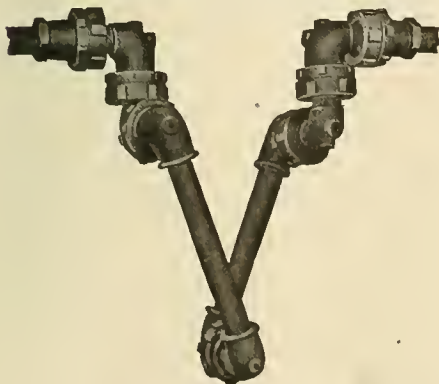

Fig. 33.

May be applied between Locomotive and Tender. These Swing-Joints are suitable for Steam, Gas, Air, Water or Oil.

Complete Booklet on Application  
**L. J. BORDO CO.**  
PHILADELPHIA, PA.

tor was thus avoided. The man still carries the card case, but there is no pass in the place where there was one for a long time. Instead there is a white card bearing the picture of a massive tombstone, on which is inscribed: "Pass. Gone but Fondly Remembered."--*New York Tribune*.

### Coal Storage.

In looking over the illustrated and descriptive pamphlet got out by the Western Electric Company, of Chicago, concerning their plant called the "Hawthorne," one is struck by the mention of a method of coal storage adopted at these works, which is comparatively new in this country. The method, which is that of storing coal under water, has been successfully tried at Portsmouth, England by the British Admiralty. This method eliminates the chance of spontaneous combustion, and largely prevents the deterioration of the coal before it is used. Speaking of this method the com-

value after six months to a year storage. By this system of storage there is provided sufficient coal to operate the plant, under normal winter conditions, for four months."

A recent press dispatch from Coatzacoalcas in Mexico states that President Diaz and his party, participated in the opening of the Tehuantepec Railroad, crossed the isthmus the first freight transported by the road was transferred to the steamer Louis Luckenbach, under the supervision of the president. After the opening ceremonies the president and his party inspected the port works.

Within the past few months new branches have been opened by the Johns-Manville Company of New York at New Orleans, Dallas and Baltimore, so that the company now has 16 branches throughout the United States, and a new branch has just been opened at 214 Main street, Buffalo. This branch will be under the man-



LEVEL CROSSINGS ALMOST UNKNOWN IN GREAT BRITAIN.

pany says in the pamphlet: "Continued uncertainty of the coal supply, due to strikes and other conditions beyond the control of the manufacturer, has led to a careful consideration of the problem of coal storage. The Western Electric Company, after carefully investigating the question, decided to follow the practice adopted by the British Admiralty. Two storage bins, one of 4,000 and the other of 10,000 tons capacity, both located below the normal ground level, have been constructed, into which coal may be dumped from cars and taken out by means of a locomotive crane fitted with a grab-bucket. Carefully executed tests in Europe show that nearly thirty per cent. of the heating value of coal is lost in six weeks when stored exposed to the air. By keeping the bins flooded, the company expects to reduce the losses of the coal to approximately two per cent. of its heating

agement of Mr. Geo. A. Schmidt, who is well known throughout that section. Mr. B. F. Boscoe has been appointed assistant manager of this branch, and will make his headquarters in Rochester, N. Y. Mr. Harry V. Patton, formerly manager for a local asbestos house, will also be associated with the new Buffalo branch.

### Compounds in Great Britain.

It is interesting to note that after eighteen years experimenting with various types of compound locomotives, the leading railways in Great Britain are gradually abandoning the compound for the simple engine. Many of the older compound locomotives have been scrapped, and others of more recent construction have been rebuilt as two-cylinder simple expansion engines. The Great Western Railway of England had up till recently placed much reliance on the De Giehn com-

This illustration shows the form of construction of the

## Dart Patent Union

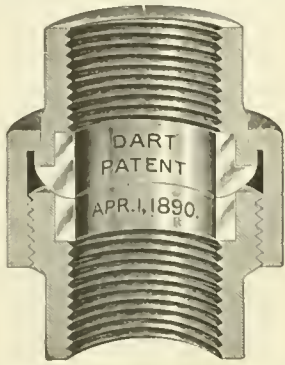

Every feature of construction represents the best points to insure stability and durability. The malleable iron pipe ends and nuts, in combination with bronze metal seats, are as near perfection as is possible to approach, and the sales to date indicate the public approval. There are none so good. For sale by all the principal jobbers in United States, Canada and Europe.

**E. M. Dart Mfg. Co., Providence, R. I.**  
FAIRBANKS CO., SALES AGENTS.



## The Twentieth Century Master Mechanic

Won't use Solid Mandrels.  
Cost too much, take up too much  
room and don't give satisfaction.

### Nicholson Expanding Mandrels

Take everything from 1 to 7 inch  
holes. Take up little room—  
always ready and you can buy  
four sets for the cost of one of  
the solid kind.

### Are You Using Them?

Catalogue tells you  
more about them.

**W. H. Nicholson & Co.**  
Wilkesbarre, Pa.

pounds. Their adoption of the Bousquet type of the De Glehn compounds had established a superiority for that type which is passing away, and in a series of tests with Mr. Churchward's magnificent two-cylinder simple engines it has been found to the complete satisfaction of the British experts that the latest 4-4-2 and 4-6-0 types will take a load of 50 tons in excess of the compounds at the same speed.

#### Strong Tubes.

Mannesman tubes four inches in diameter have been made which stand a pressure of 2,000 pounds to the square inch. The first tubes made to stand this pressure were for a water-main in Chili.

The enormous tensile strength is due to excellent steel being worked into spiral form. Chrome steel could probably be made to stand a higher pressure. Thomas Prosser thinks that Krupp special chrome steel tubes made in the same way might stand a pressure of 3,000 pounds to the square inch. That steel has never been known to fail in automobile construction.

Castiron tubes that are so often laid under our streets will not stand a pressure of more than 200 pounds to the square inch, and welded tubes one-quarter inch thick have a limit of about 1,000 pounds.

#### Miner Entombed.

Some time ago a miner named Hicks was buried under a fall of earth and rock in one of the subterranean galleries of a mine in the mountains near Bakersfield, Cal. He was held down by iron rods under a heavy car. He had with him at the time of the accident one of the hack saws made by the L. S. Staratt Company, of Athol, Mass., and with this saw he managed to cut the rods which held him down, and in this way, gained his bodily freedom, though still seventy feet below the surface of the earth, and was actually imprisoned for fifteen days. He was, however, finally rescued and keeps the saw as a memento of his terrible experience.

#### Jointer Guard.

A shop safety appliance for wood-working tools was on exhibition at the Safety Appliance Show in New York last month. It was nothing more or less than a sheet metal guard for a jointer, and when the machine was working and the man in charge was engaged in pushing the pieces of wood along the table and over the cutter, he was completely protected from contact with the knives.

The device is made by J. M. Jones, and consists of a series of light sheet metal plates, supported on a convenient stand clamped to the side of the machine. The metal plates slide out, one

under the other, telescopic fashion, if one may so say, and they are each curved up slightly so as to be a little higher in the middle and the edges are rolled under so as to make a smooth surface in which fingers and clothes cannot catch. The object of the extension arrangement or the telescope idea as we have called their movable fit, is to allow the guard to be carried out so as to cover a cutter of any width.

The operator, when pushing a piece of wood along, if careless, is liable to let his hand come in contact with the knives, with disastrous results. If the machine is fitted with the Jones jointer guard his fingers would simply slide up on to the metal sheet and remain good, undamaged fingers, as far as that part of the operation was concerned. When not required, the guard can be swung out of the way, and it is easily adjusted to any required height or to any width of table.

#### Willie Weary, Blacksmith.

BY T. TOOT.

"Look here, Toot, am I ever going to get that frame for 4-11-44 that came in a week ago?" and the M. M. looked at me with his corkscrew eyes and his side whiskers bristling out like the gills of a game fish, ready to sprinkle a little salt on me and down me at one gulp—"and, there's that crank shaft for the alligator shear," he went on after getting his breath, "and a hundred other things," he continued, "we are waiting on to get, and need badly." He gave an extra twist to his eyes that made me feel as if a gimlet was piercing my abdomen.

I managed to articulate that I had no one to depend on to do the frame and shaft as my best smith was off with three broken ribs from a fall from a telegraph pole where he had climbed to get away from the little blue devils that were chasing him, and the other man had been unfortunate enough to hold his finger on a tool too long and the finger was somewhat bruised. "Mr. Chasen," I said, "I will try to do those two jobs myself so you can get them, and I will try and get some more smiths." The M. M. gave me another hair raising look. "Fire the rascals out, Toot, if they don't do better and hire anybody that comes along, and get a hustle on that frame." The M. M. hurried off down the shop, only hitting the mounds and protuberances in his usual way. I was just in the act of peeling off my vest to get busy when in walks one of those specimens of the genus globe trotter that make a specialty of one week stands and have an unlimited capacity for rest; he ambled up to me and doffed his dilapidated touring cap.

**STANDARD MECHANICAL BOOKS  
FOR ROAD AND SHOP MEN  
BY CHAS. McSHANE.**

**The Locomotive Up to Date**

Price, \$2.50

**New York and  
Westinghouse Air Brakes**

Price, \$1.50

**One Thousand Pointers for  
Machinists and Engineers**

Price, \$1.50

All books bound in fine cloth.

AGENTS WANTED everywhere; write for terms and descriptive circulars. Will be sent prepaid to any address upon receipt of price.

**GRIFFIN & WINTERS**  
171 La Salle Street, CHICAGO

**TOOL  
STEEL**

**Die Blocks  
Steel Forgings**

First Prize awarded at the Louisiana Purchase Exposition, at St. Louis, for our **TOOL STEEL** when placed in competition with the best makes in England and Germany.

Write for Information and Prices. Specify McInnes Tool Steel when ordering.

**McINNES  
STEEL CO.**  
Corry, Pa.

"Is you'se de boss? If ye is, I wants a job as a smit', and I want it bad, too."

I did not have the least doubt about the latter part of his oratorical effort, but his being a smith, and the kind I wanted just then, was very problematical. However, I asked him a few questions, and found out he had worked at some excellent places, that is if he was not handling the truth too carelessly. I asked him if he had ever done any frame work and his reply was, "Sure, Old Times, that's me long suit"; but to get a line on him I gave him some tools to make and I could see that he knew his business all right.

I thought I would let him tackle the crank shaft next. So I made a rough sketch for him, shown in Figs. 1 and 2, and after I had given him a few pointers as to the way I would go at it, he stopped me with, "Say, Roxy, I see you ain't made a crank shaft lately." I admitted the allegation. "If youse lets me do dis job de way I wants to, I

and as the frame was broken through one of the holes this is the way he went at it. Fig. 5 shows the break. Fig. 6 the way he cut his V's out. I was keeping a close watch on him and when he began to sink a chisel in the sides I began to get suspicious, and remarked to him, "Weary, I don't want you to get tangled up on that job, and if you don't think you can manage it I will help you out." He gave me a look that spoke louder than any of Lord Byron's bizarre poems, squared his shoulders and delivered himself as follows:

"Look here, Old Honey Chum, ain't I demonstrated to your Daniel Webster intellect dat I am de real ting? There's no four flushing about Weary. So youse just go down in your palatial boudoir, keep very quiet for about a couple of hours and we will have dis foundation of de running gear of 4-11-44 done to de orders and specifications of de Princess of Bulgaria." I had to take his word for it, so went off and took a back seat, remarking to him as I went

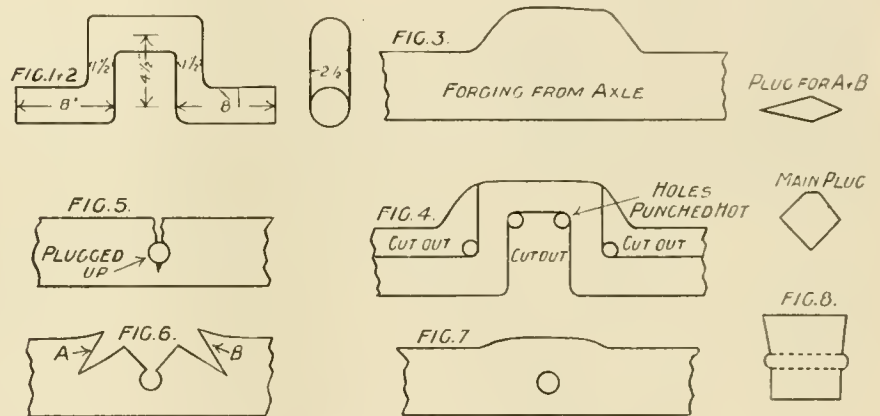

HOW THE WORK WAS DONE.

will guarantee it O. K., and in about half the time it usually takes." So as I could not do otherwise than let him do it his way I told him to fire ahead and do it. I must say he did an excellent job, and this is the way he did it. Fig. 3 shows the way he got the rough piece out, and No. 4 shows the way he roughed the piece out for finishing, and I must say when it was done it was surely a work of art, and he did the job with the least effort of any one I ever saw do this class of forging. After he had laid it down I was measuring it up to see if it came up to specifications. He slapped me on the shoulder and says, "Say, Pal, ain't she a peach?" I had to admit "she" was all right and as I had no doubt as to his ability to fix the frame I gave him orders to go at the frame at once. He smirked and remarked, "Old Pard, I just dote on frames, and if you will give me plenty of help I will have it done in a jiffy."

I sent him all the help he wanted,

away that the man on the next fire would heat the dab for him; but Weary had to have the last word and he called me back, saying:

"Say, Old Wise Head, Weary is one of de boys what don't sit on de back row on anything in his line, and I'm on to de job proper, so keep your blinkers on Weary for awhile and you'll see tings dat will make 'em pop out like de danger lights on an automobile." I took his word for it and watched proceedings from a distance. He got out suitable pieces for the side V's, and then the main dab to fit in the recess tight, so A and B pressed hard on it, and the whole arrangement was held together securely.

When this was done Weary bade the helpers build a special fire for him, and came to me with, "Say, Old Pard, have ye any burnt borax?" I took him to the office and showed him the article we used. Weary looked at me with pain and disgust.

"Oh, my innocent one, I see your

# One Year and Eleven Months' SERVICE

WITHOUT REPACKING, ON

## High-Pressure Locomotives

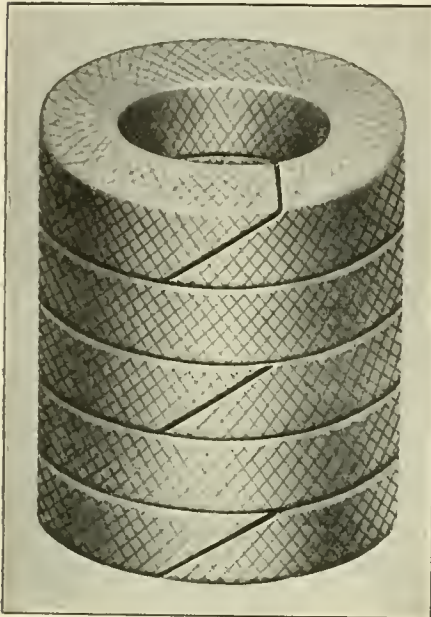

Style 300 IV.

A throttle failure is an absolute impossibility where Crandall's Throttle Valve packing is used.

IT WILL NOT BLOW OUT

## Crandall Packing Co.

FACTORY AND GENERAL OFFICE

PALMYRA, - - NEW YORK

BRANCHES

New York  
136 Liberty St.

Cleveland  
9 So. Water St.

Chicago

52 West Washington St.

# Patents.

GEO. P. WHITTLESEY

McGILL BUILDING WASHINGTON, D. C.

Terms Reasonable Pamphlet Sent

## Molding Machines

Vertical Vibration Power Draft  
ALL KINDS OF MACHINES

THE E. H. MUMFORD CO.  
17th & Callowhill Streets, PHILADELPHIA, PA.  
J. W. JACKMAN & CO., Ltd., 39 Victoria St.,

education in the rudiments of practical chemistry has been sadly neglected. Produce de raw article and I will proceed to have you quaff at de fountain of knowledge," and he proceeded to show all of us the way the best flux I ever saw is made.

He took a piece of light sheet iron and put it over a hole he dug in the floor, hit it a few raps with the sledge and made a bowl of it, filled the bowl with raw borax, put it on a fire and reduced it to liquid like molasses, removed it and poured it on the face plate, and when cold he had a thin sheet of stuff that looked like glass. He next pulverized this to powder, and it was made. A very small amount was used on the iron and was applied or dusted over the welding heat when taken from the fire, and it is surprising the way it held the heat while being worked. I quaffed at Weary's fountain of knowledge in this particular as well as some more kinks of his. Weary's fire for the job was another new one on me, as it was very short and wide and just high enough to be above the frame when placed in position. He next had a fire built on another forge with well burned coke, and this white hot coke was used as a feeder while the frame was heating.

In placing the frame he put the unprepared side next the fire first, with a piece of heavy pine board on top of the fire to help hold the heat, and when it was white he turned it over, put on a good supply of white hot coke, and in no time had a fine heat and a solid job, which he left in the shape of Figs. 7 and 8. He did not trim off any stock, but proceeded to prepare the other side in precisely the same way, and after welding it down in the same manner trimmed off all surplus stock with a good sharp chisel, smoothed it up nicely and certainly turned out a nice job, and did it quickly.

I complimented him on his good work and wanted to know where he got on to his new kinks, and he answered thus: "My good Old Timer, if you want to get wise to tings going on in dis world, just hit de pike for a few moons and you'll see all kinds of new tings dat will do your heart good.

The executive committee of the Master Car and Locomotive Painters' Association at a recent meeting decided upon the city of St. Paul, Minn., as the next place of meeting for the annual convention of the association. The Ryan House in that city will be headquarters and the meeting will take place from 10th to 14th of September. Members and others desiring to attend should write to Wm. H. C. Quest, 172 Randolph street, Chicago, for special hotel arrangements.

**CYLINDER BORING BARS**  
**VALVE SEAT ROTARY PLANING MACHINES**  
**CRANK PIN TURNING MACHINES**

*Write for Catalog*

**QUINCY, MANCHESTER SARGENT CO.**  
**OLD COLONY BLDG. 114 LIBERTY ST.**  
**CHICAGO NEW YORK**  
**Machinery Sales Dept.**  
**PLAINFIELD, N. J.**

**SKAT!**  
Off Comes the Dirt.

When the hands are smeared and stained with a greasy grimy coat of oil, soot, dust and dirt, rub on a little

**SKAT**

TRADE MARK

**The Best Hand Soap Known**  
and see how quickly they're clean and soft again. SKAT is made to do what ordinary hard soaps can't do. Gets into the pores and loosens all the dirt so it simply rinses off. Pure, effectual and beneficial to the skin. 10 cents a can.  
Write postal for free sample and we will tell you where to buy SKAT, or if not sold in your locality, will tell you how you can become our exclusive agent and make money selling it. Write to-day.  
**THE SEAT MANUFACTURING CO.,**  
**807 Park Street, Hartford, Conn.**

**CONTENTS.**

- \*The Rotary in the Rockies..... 99
- Steel Making..... 101
- \*Patent Office Department..... 104
- Civilizing Influence of Roads..... 106
- \*General Correspondence..... 107
- Locomotives:
  - \*Compound for the Mexican National... 103
  - \*German Tank Engines..... 105
  - \*First Scottish 4-4-2..... 109
  - \*Tank Engine for Nevada Northern..... 113
  - \*Simple Baldwin for Woodward Iron Co.. 118
- Shop and Engine Appliances:
  - \*Water Glass Guard, Mo. Pac..... 106
  - \*Iron Wedge and Table Lock..... 108
  - \*Air Bell Ringer..... 110
  - \*Fireproof Smoke Jack..... 129
  - \*Automatic Switch Closer..... 130
  - Self-Closing Water Glass..... 137
  - Railroad Safety Lamps..... 140
  - Jointer Guard..... 142
  - \*Stephenson Valve Gear, Adjusting, Jas. Kennedy..... 110
  - \*Steel Gondola Dump Car..... 112
  - Mountain Railway, First..... 112
  - Book: The Six-Chord Spiral, Stephens..... 117
  - \*Correspondence School, Our..... 119
  - Questions Answered..... 121
  - \*Air Brake Department..... 123
  - \*Electrical Department..... 127
- Editorials:
  - Power of Organization..... 114
  - Museum of Security..... 115
  - Railroad Investigations in Germany..... 115
  - Industrial Agreements..... 115
  - Technical Education of Apprentices..... 116
  - Safety Appliances Exhibition..... 116
  - Scottish Railway Disaster..... 117
  - Cuban Railways..... 117
  - Cylinder Relief Valves..... 129
  - First Train Dispatcher..... 130
  - \*Personals..... 131
  - Coal of the World..... 134
  - \*Track Insulation on Steel Bridge..... 136
  - Locomotive Tonnage Rating..... 138
  - \*Willie Weary, Blacksmith, by T. Toot... 142

# Railway and Locomotive Engineering

Copyright by Angus Sinclair Co.—1907

A Practical Journal of Railway Motive Power and Rolling Stock

Vol. XX.

136 Liberty Street, New York, April, 1907

No 4

## The Great Tunnel.

There are on the Denver, North-western & Pacific Railroad as many as

amount to over  $3\frac{1}{2}$  miles. Our frontispiece this month gives a view from one of the short but similar tunnels on an-

make a pathway for the iron horse may in some measure be gained by a glance at the forbidding faces of the

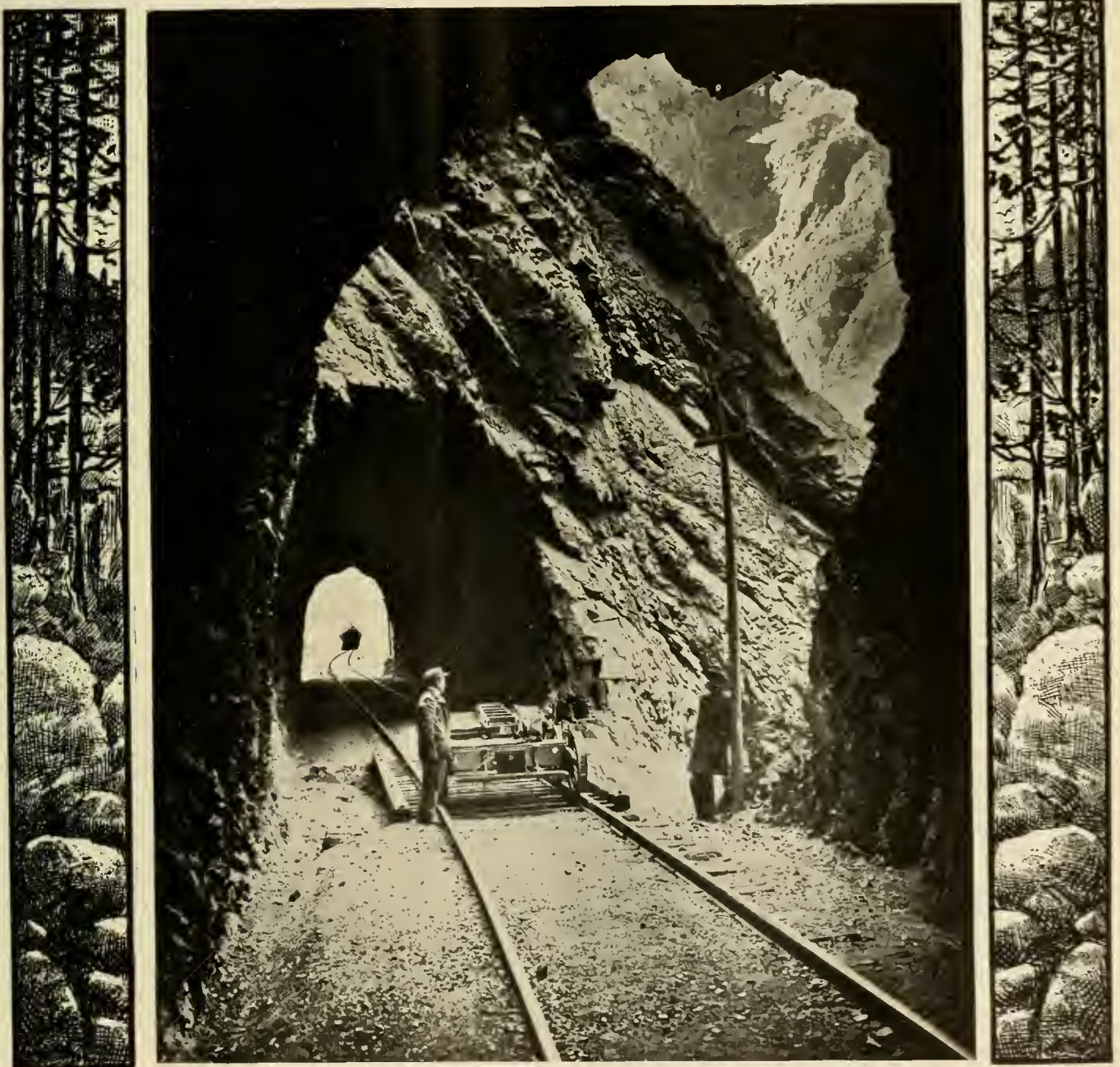

VIEW OF A SHORT TUNNEL AND THE PORTAL OF A DISTANT ONE, SEEN FROM THE INTERIOR OF ANOTHER.  
(Stereograph, Copyright, 1906, Underwood & Underwood, New York.)

thirty-four tunnels in a distance of fifty miles out of Denver. The length of all these tunnels would, if added together, other road taken from the interior of the bore, and the laborious work of penetrating solid rock in order to mountain slopes which must be attacked by the civil engineer in order that a nation's commerce may flow safely

through, rather than over, these natural ramparts of stone.

A great work has but recently been accomplished in Switzerland—the success-

and through numerous galleries and tunnels cut in the rock, and in places it is built upon solid masonry which fills narrow gorges. There were about twenty

the work has been 6 years and 9 months.

Numerous obstacles were encountered in the work of driving the tunnel, of which Mr. Francis Fox gives details in an admirable paper read recently before the Institution of Civil Engineers of Great Britain. Among other things he says:

"The work of excavation progressed rapidly at both ends, an advance of 18 ft. per day being frequently recorded. On the Swiss side the rock encountered chiefly was gneiss and micaceous schist. On the Italian side, after traversing about  $2\frac{3}{4}$  miles of hard Antigorio gneiss, the thermometers in the rock showed a diminishing temperature, and suddenly a cold underground river of 12,000 gallons per minute burst in. Owing to the treacherous nature of the rock at this point only heavy joists buried in quick-setting concrete were able to hold open a heading of sufficient area to give access by small hand wagons to the drills beyond. This short length entailed a delay of 6 months.

"After traversing another  $2\frac{1}{4}$  miles, hot springs with a maximum flow of 4,330 gallons per minute and a temperature of about  $113^{\circ}$  Fahr. were encountered, but by taking the water of the cold spring and throwing it into the crevices of the hot, the heading was made bearable.

"During these delays to the south end, the north end had been advancing with increasing rapidity, and had reached the central summit of the tunnel; to avoid delay, however, the heading, hitherto on the level of the floor of the tunnel, was made to rise on a gradient of 1 per 1,000.

"When the advance heading reached the roof level of the future tunnel, working down hill was attempted, but finally work on the Swiss side was abandoned, the drills were withdrawn and the heavy iron doors which had been erected were closed March 20th, 1904. Completion was thus left to the south advance, whose



PORTAL AT BRIEG ON THE SWISS SIDE, SHOWING THE UNFINISHED ENTRANCE TO THE RIGHT OF THE PICTURE.

ful opening of the Simplon tunnel on the line of the Jura-Simplon railway. The Simplon mountain is one of what are called the Lepontine Alps, this range forming part of the boundary between Switzerland and Italy. The Simplon mountain rises to a height of more than 11,000 ft. above sea level, and along one shoulder of it winds the famous Simplon pass, the roadway reaching a height of 6,592 ft. The pass itself leads from Brieg in the valley of the Rhône, to Domo d'Ossola, a village on the river Toccia, which flows into Lake Maggiore.

One of the greatest engineering achievements of the early days of the last century was the construction of the Simplon road. It was begun in 1800 under the direction of Napoleon, chiefly for military purposes, and was completed in 1806. It was a wagon or carriage road about 25 or 30 ft. wide, and its maximum gradients were about 1 in 13, or nearly 8 per cent. The road passes over 611 bridges

houses along the road for the shelter of travelers. The road suffered severely from storms between the years 1834 and 1850.

The altitude of the Simplon tunnel is 2,313 ft., or more than 4,200 ft. lower than that of the pass. The tunnels, for there are two of them, are separate excavations about 55 ft. apart. At present only one is completed, the other being as yet only a through heading. The mouth of the unfinished one may be seen in our illustration of the portal on the Swiss side. These separate tunnels will be connected by oblique passages for the purpose of ventilation and drainage while building and for facilities in working traffic when completed. The tunnel now in use is about 16 ft. 5 ins. wide and 18 ft. above rail level. It is lined all the way through with masonry. The cost was about £3,200,000, or about \$1,552,000,000, the Swiss and Italian governments being the principal contributors. The time taken to do



SAND BLAST CAR FOR RAIL BONDING.

drills could just be heard through the intervening 1,094 yards of rock.

"On the 24th February, 1905, at 6 a. m., the final charges on the Italian side were exploded in the roof of the gallery,

blowing a hole about 8 ft. by 2 ft. into the floor of the Swiss heading above.

"The first train passed through on the 25th January, 1906, and on the 19th May the King of Italy travelled in a special



VIEW OF DIFFERENT LINES AT BRIEG.

train to meet the Swiss President at Brigüe, who returned with him to Domo d'Ossola; the final opening to the public taking place with great festivities on the 30th May, 1906."

The tunnel is  $12\frac{2}{5}$  miles long, being the longest in the world. The central portion is approximately level for about 1,600 ft., with  $2/10$  per cent. down grade toward the Swiss end and  $7/10$  per cent. toward the Italian end. The tunnel is ventilated by large fans, one at either end. Steam locomotives were originally used to work the traffic, but these have been replaced by electric locomotives built by Brown, Bouvier & Company, of Baden, Switzerland, to whom we are indebted for photographs of the tunnel and data concerning the electric equipment.

Referring to the electric locomotive the builders say it is of the bogie type with five axles, of which three are driven by the motors. The traction motors, as they are called, are placed between the three pairs of driving wheels, and both drive on the middle axle by means of a bar coupling them rigidly together. This axle in turn drives the other two by means of coupling rods, so that there are no gears. The motors not being on the axles, the work of dismounting them for repairs is therefore facilitated. The following are the leading dimensions: Length between buffers, 40 ft. 6 in. Total length between axles, 31 ft. 10 in. Distance between driving axles, 16 ft. 1 in. Distance between bogies, 23 ft. Diameter of the driving wheels, 5 ft.  $4\frac{1}{2}$  in. Diameter of the smaller wheels, 2 ft.  $9\frac{1}{2}$  in. Weight on the driving wheels, 42 tons. Weight of the electrical portion, 28 tons. Weight of the mechanical portion of the equipment, 34 tons. Total weight, 62 tons. Normal output of the two motors together, 900 H. P. Maximum output of the two motors together, 2,300 H. P. Weight of the motor complete,  $10\frac{3}{4}$  tons. Speeds, 42 miles per hour and 21 miles per hour. Draw bar pull at 42 miles per hour, 7,700 lbs. normal; 20,000 lbs. maximum. Draw bar pull at 21 miles per

hour, 13,500 lbs. normal; 31,000 lbs. maximum.

The locomotives are built on liberal lines. When starting at the higher speed with a passenger train weighing 300 tons, a draw bar pull of 16,600 lbs. is required in order to obtain the specified acceleration, and when starting at the lower speed with a goods train weighing 400 tons a draw bar pull of 20,000 lbs. is required to obtain the specified acceleration. The traction motors are each rated at 450 H. P. and work with three-phase current at 2,700 to 3,000 volts, 16 cycles. Their momentary overload capacity is as high as 1,150 H. P. per motor at the higher speed. At the lower speed they are rated at 390 H. P., but can be overloaded continuously up to 575 H. P. The chief feature of the construction of these

ning arresters and a line switch to the emergency switch, which is placed in the roof of the locomotive. From this the circuits pass directly to two busbars and then through fuses to the reversing switch which controls the direction of working of the locomotive. Then they pass to the pole changing device which controls the speed at which the locomotive works, and finally to the motors themselves. The third phase is brought in from the rails themselves, and, as in the other two phases, the current passes through the reversing switch and the pole changing device before reaching the motor.

The resistances are placed at each end of the locomotive under the driver's cabin, there being one set for each motor. They are built of a network of wires,



PORTAL ON THE ITALIAN SIDE AT DOMO D'OSSOLA. ENTRANCE TO BOTH TUNNELS CLOSE TOGETHER.

motors lies in the pole changing device by means of which two speeds are obtained.

Current is collected by means of the bow contacts from the two overhead lines, and connected through the light-

the electrical resistance of which is exceedingly high. Doors are provided on each side in several places so that they can be readily inspected.

They are artificially cooled by means of four ventilators placed in sets of two

at each end of the locomotive. These are driven by small motors so connected that they start up when the main motor starts, and are automatically cut out of circuit as soon as the main motor gets up to full speed. At this moment the resistances are no longer in circuit, so that no further ventilation is necessary. These resistances are so dimensioned that they can remain permanently in circuit, allowing the locomotive to run continuously at any intermediate speed.

All the high pressure apparatus, the reversing switch, the pole changer, and the current transformer, are enclosed behind a sheet metal partition, which can only be opened when the collecting bows are not in contact with the overhead line. There are two current collectors mounted one at each end of the locomotive roof. In the tunnel itself, where the height of the wire is 17 ft., the frame is lowered right down.

The power necessary to drive the compressors and part of the lighting is supplied by a small oil transformer fitted to the locomotive platform and connected to earth. The compressed air is supplied from two Christensen piston type compressors driven by small electric motors. They have to supply the necessary compressed air for the Westinghouse brake, the whistle, the sanding gear and all the pneumatically controlled apparatus. Each

It is a remarkable fact that last year saw the opening of the Simplon tunnel, its traffic worked by modern electric locomotives, with power drawn from torrents which flow from the snow capped mountain heights, the "white coal of the Alps." The tunnel unites in friendly commercial intercourse the peoples of two diverse nationalities. It is just one hundred years since the completion of the Simplon road by the great Napoleon, but the new highway does not echo to the tramp of armed men. In 1806 Napoleon was almost at the zenith of his power, with his war-loving ambition still unsatisfied, the practical embodiment of the despotic military spirit, sinister and destructive. The year 1906 has seen success crown the patient labor of applied science, devoted to a constructive work, as noble in its conception as it is in its achievement. The grim glory of battlefields may haply pass away, but the road from Valais to Piedmont will endure. "Peace hath her victories no less renowned than war."

#### Reminiscences of an Old-Timer.

BY SHANDY MAGUIRE.

When a man goes into the graveyard of the past to resurrect dead memories and again animate them with life the trip may not yield much pleasure, for, if his head of hair has taken on life's

ticularly as engineman. Think of when you were a boy and you stood convenient to some railway crossing to watch the engine dash past you, and think of the envious look you gave at the men who were perhaps exhausting

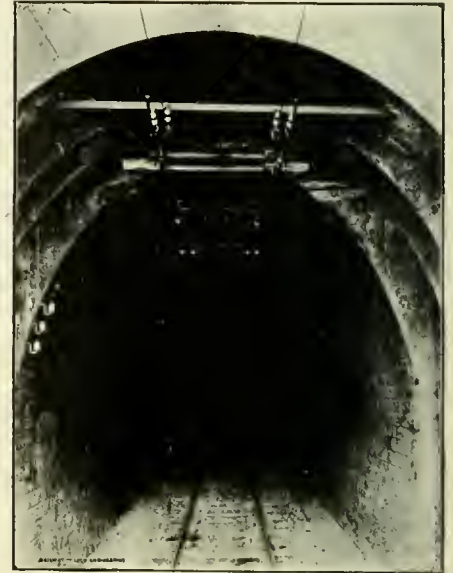

INTERIOR OF THE TUNNEL.

all their efforts to make her dash faster, whom you exalted into demigods, and wished for the day to come when you could be employed like them. I remember reading of a young granger writing a letter to a master mechanic asking for a position on a locomotive, giving as his qualifications "he could look out for cows as good as either of the two fellows sitting on the seats, as he always satisfied his father by keeping his eye to business."

I suppose it was fate directed Paddy Ryan to go to the master mechanic of the Oswego and Syracuse division of the Lackawanna Railroad to solicit a job firing one day in the early seventies. He was sized up by that mighty dignitary in a three-seconds' glance just as critically as he could be nowadays in a fifteen-minutes' roustabouting by the autocrats of that hope-frustrating hell known as "the eye and ear car." He passed muster, and got a job block tossing on a 16 x 24 Rogers engine, known as the Skinner. This engine had two domes, with the whistle on the forward one. The domes were covered with brass, also the wagon-top, the bell, bell standards, the jacket bands, the edges of the running boards, the steam chests and cylinders, the brackets around the headlight, the flagstuffs, and every other place an ornament could be attached to, which included a brass eagle, with big wings, extended, on the sand box cover. Paddy, by way of exercise, when not tossing the blocks, had to scour all these enumerated parts from once to twice a day, besides making 35 miles to Syracuse and 35 miles back to



ELECTRIC LOCOMOTIVE USED IN THE SIMPLON TUNNEL.

compressor supplies 14½ cubic feet of air per minute at a pressure of 110 lbs. to four cylindrical reservoirs which are mounted two and two at each end of the locomotive. All the compressed air pipes are fitted with return valves so that they may be operated from either of the two controllers, so that if either of these is not in order the locomotive can be driven from the other.

autumnal hues, he is likely to be reminded of those glorious times when hopes were high and the nectared wine of the long ago had a flavor to the taste of his earlier years never to be equaled by a later vintage.

Among all the occupations which a young man looked for, say 30 years ago, there was none he so earnestly hankered after as railroading, par-



Oswego, for that magnificent piece of the mint known as "the dollar of our daddies," and if it took a couple of hours into the ensuing day to make the round trip the 50 cents each way would not be increased a single dime. Remember that all this happened in those "dear old days" before the birth of the Grief Committee.

Tom Dayton, as slick a gent as ever admired himself in a mirror, was the engineer of the Skinner, and he loved Paddy with that same volume of affection that the devil is supposed to carry about in his dressing case for holy water. Tom and Paddy never could mix. They often kept the cab much hotter than the firebox with their tongue-walloping set-to. Dayton was not able for Paddy with the dukes, but he had a way of getting even which laid him out worse than a solar plexus thump. All he had to do was to carry three full gauges of water, if no more, then when it was signal station time, to open the whistle wide and, it being on the forward dome, the water which would fly back would speckle the brass for Paddy to massage again. In fact, he fairly reveled in oxalic acid and rotten stone between trips for desserts, all because Dayton wanted to run him off the Skinner. "Did he succeed?" "Well, I guess not," says Con. "Bide a wee, and you'll find out."

It was in February of 1871 that the heaviest snowfall of the winter came. Snow-plows were kept running constantly for a while, but the end came

an engine and keep her from dying out in a snowdrift. Next to burning one, letting one die out on the road in stormy weather was considered the greatest crime, and the old reliable method of jacking up so as to use the pumps, was the only hope.

As the engineer in those days was the chief cockalorum and high driver-general, his orders were obeyed at all

not half as good backing out as you are."

"You get down off that seat and back the jacks out to the front until I pump up."

"Are you in a hurry?"

"I want no fooling from you, but do as I tell you, I have but one gauge of water."

"That's more than I thought you had,



VALLEY OF THE RHONE. LOCOMOTIVE AND CARS AT THE NORTH PORTAL.

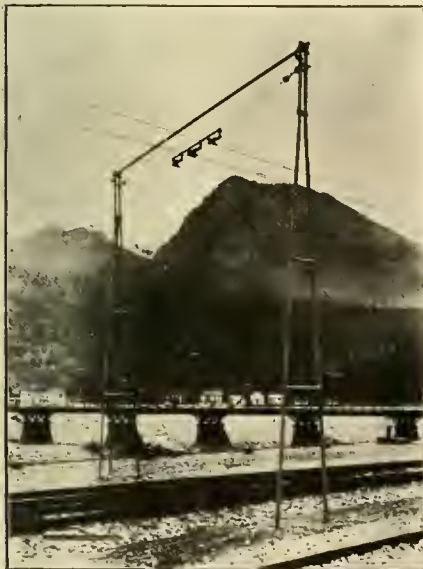

OVERHEAD WIRE SUSPENSION.

one day as the wind took a hold. In those days injectors were a rare commodity, and when placed on an engine were as unreliable when required for duty as the promise of a young maiden with several suitors. But one trustworthy way was left to get water into

times. His most reliable man was the fireman, and to the credit of those old time block tossers I'll say that they could be depended upon in nearly every case.

Running between Fulton and Minetto, eight miles apart, was considered ticklish, as there were many drifts. The Skinner, being the heaviest engine, was always depended upon for breaking the road.

Paddy was after having a protracted spell of rag-chewing with Dayton, and was lying low to get even. His chance came gloriously at last; Dayton sent the Skinner for all she was worth with three coaches and a baggage car behind her for the Red Cut. He drove her into it up to the running board; he staked his chance of going through the drift. He knocked off his pump, got the benefit of 20 additional pounds of steam to help him along, and heard the safety valve blowing merrily—so did Paddy. Down went the reverse lever into the 19-inch notch as she began slowing up, but it did no good, for she made but a few exhausts more till she gave up the tussle, and stopped dead. Over came the reverse lever, and out to its widest limit came the throttle to back out, but she never made a kick.

"Arrah, Tom," says Paddy. "She's

and more than you deserve, from the way you knocked the water out of her coming into this cut, thinking you could get through."

"I want you to get out the jacks and get to work, and cease your gab."

"All right, Tom. Lead the way and I'll follow the leader. You will get a dollar for this trip, while I'll get but the half of it, but I'll do as much work as you."

Dayton had to plow waist deep through the snow with a 26-inch plug of a rusty jack on his shoulder and Paddy followed after with the other jack and both levers.

"Come, come! Hurry up and get these jacks set," said Dayton.

"Tom, I always was told to never take a tool out of a man's hand, and I'll not commence now."

"But the water is going out of the lower gauge."

"God speed all travelers, Tom. I wish we were going also, but, judging by the looks of things, we'll enjoy a spell of weather here."

There was no shovel brought out to clean a place for the jacks. Dayton told Ryan to go back and get it. He went, but was slow in his movements. Dayton took it out of his hand, and, after shoveling a while, the jacks were

set, but the engine would not lift unless more help was coming, which did not look likely, as the conductor and his baggageman were the only employees on the train.

"I'd advise you to go back and try the water," says Paddy. "She is blowing off the little she has in the boiler."

you haven't a nearer friend than me to say the litany over both of you."

The snow was so high and heavy it was impossible for them, in their present condition, to save the engine from freezing by taking down pipes and pumps. Dayton was demoralized, but Paddy had a card up his sleeve, and

die in the Red Cut, because you exercised poor judgment, on the 16th inst., thereby blocking the road for a week. What have you to say to the charge?"

"I did everything a man could do to keep her alive, and if my fireman had helped me out, as he should, I wouldn't be here now."

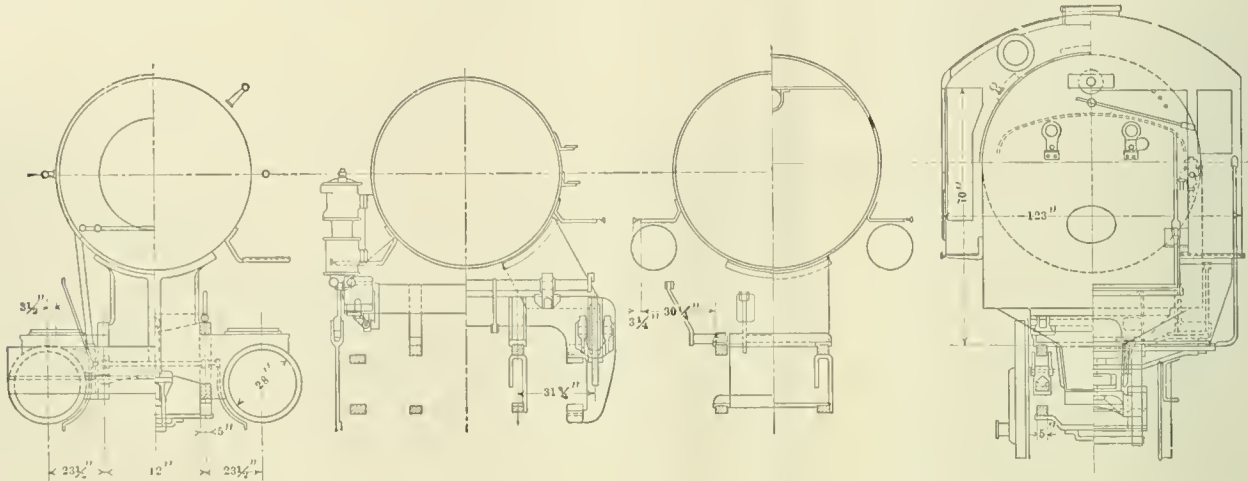

CROSS SECTIONS OF PITTSBURG, SHAWMUT & NORTHERN RAILROAD ENGINE.

He did, and found the water had left the lower gauge. Then he roared at Ryan to pass up snow, which he put up on top of the firebox full of wood until every spark was extinguished.

"Begob, Tom, she's dead; and, my brainy plug-puller, if I don't miss my guess, you'll be a dead cock in the pit, too, when the old man gets through with you."

Dayton never replied. He looked

didn't give a tinker's damn for his feelings.

The road remained idle for a week, as all the power, three 16 x 22 engines, was stuck and couldn't get out till the shovelers would come, and the Skinner was dead. An engine was borrowed from the N. Y. C. after the storm had ceased, and in a couple of days the road was opened. Dayton and Ryan were notified to be in the

"That's a blasted lie, Dayton," says Paddy.

"Mr. Ryan," said Mr. Phelps, "I am in authority here, and I'll have system conducting this examination of what was sadly lacking in the Skinner's cab. You must not speak again until called on to do so."

"All right, sir," says Paddy.

"What else have you to offer, Mr. Dayton?"

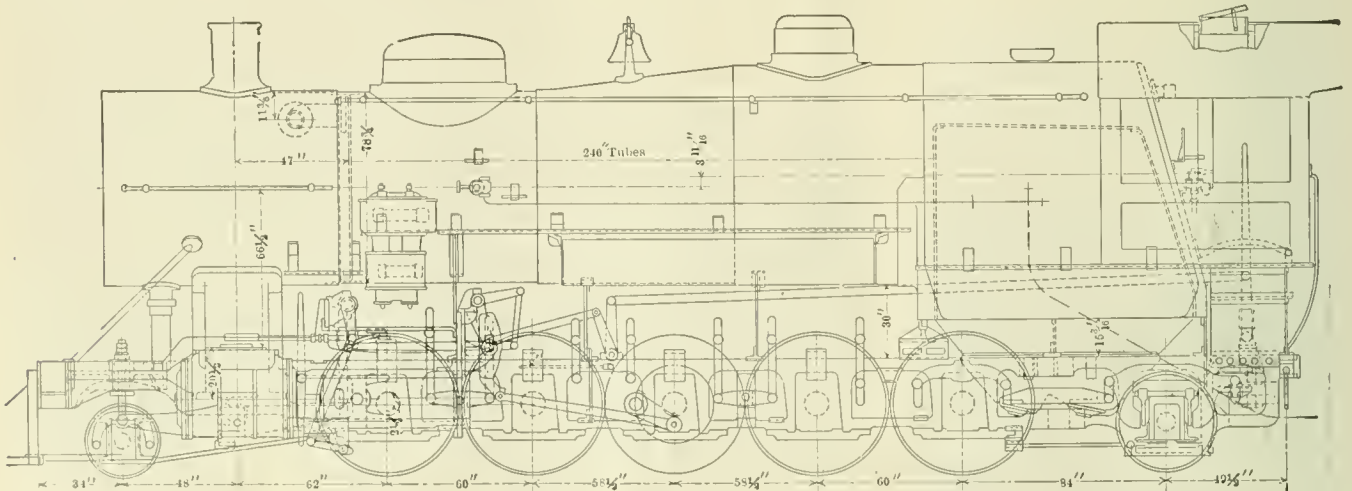

ELEVATION OF SIMPLE FREIGHT LOCOMOTIVE WITH SUPERHEATER. P. S. & N. R'D.

and felt like a man who was through with life, and Paddy helped him along graveward.

"Tom, you'll not twist your mustache in the looking-glass before your mug there passing Brant's Crossing for a spell after we get in, I don't think, me bucko," again said Ryan. "There is no use in killin' a dead dog. Your dead, the Skinner is dyin', and I regret that

superintendent's office for investigation a few days after the ball, and I give verbatim the result, as I happened to be called into the conference.

The superintendent, Mr. W. B. Phelps, who has since gone over to the majority, as humane a man as ever lived, conducted the proceedings.

"Mr. Dayton," said the Super., "you are charged with letting your engine

"That's all, sir. My fireman wouldn't help me as he ought."

"Now, Mr. Ryan, it's your turn. Give me your version of this affair."

"Yes, sir, I will, and I'll give it to you truthfully, also. I do not like being an informer, but my life has been made a hell by Dayton. No matter how good I attended to my work I couldn't suit him. Almost every day I had to

scour brass back of the whistle twice on account of the way he carries water. He'll be drowned yet, because next to full schooners of beer he loves it."

"I am waiting to hear why the engine was let die, Mr. Ryan, instead of listening to you going over the life of Mr. Dayton. Please confine yourself to it."

"All right, sir. I can give evidence enough to hang him on any subject. Now, the reason the Skinner died is because I ceased being Dayton's dog. When he got to Syracuse daily he'd go off down town and leave everything for me to look after. If he knew his business he'd never undertake to pump up an engine by jacking up the front end. I told him to get two 6 x 6 sticks, 32 inches long, and to place them up and down at each end of the front beam; to also carry four pieces of iron 2½

well as muscle, and can look ahead to be ready for trouble, you will take charge of the Skinner to-morrow morning"

Paddy demurred, and tried to save Dayton, but the Super. wouldn't have it. So he may be heard from again, in the role of engineer.

#### Simple Engine for the P., S. & N.

The Baldwin Locomotive Works have recently completed a heavy 2-10-2 locomotive for the Pittsburg, Shawmut & Northern Railroad. This engine has the distinction of bearing the construction number 30,000, and is altogether a very interesting machine. It is similar in many respects to the heavy tandem compound locomotives built for the Atchison, Topeka & Santa Fé. The principal differ-

In the matter of equalization the pony truck in front is equalized with the two forward pair of drivers and the main drivers, the two rear pair and the wheels of the trailing truck are equalized together. The wheel base of this engine is 35 ft. 11 ins., the driving base being 19 ft. 9 ins., and the engine in working order weight 288,000 lbs. With the tender the total weight comes up to 450,000 lbs. The trailing truck is of the Rushton type, with inside journals. It is equipped with a self-centering device, which brings the truck back to normal after rounding a curve.

The boiler is very similar to those used on the Santa Fé tandem compounds. The firebox is supported by sliding shoes at the front and a buckle plate at the rear. The heating surface in the boiler is 4,796 sq. ft., made up of 210 in the firebox,

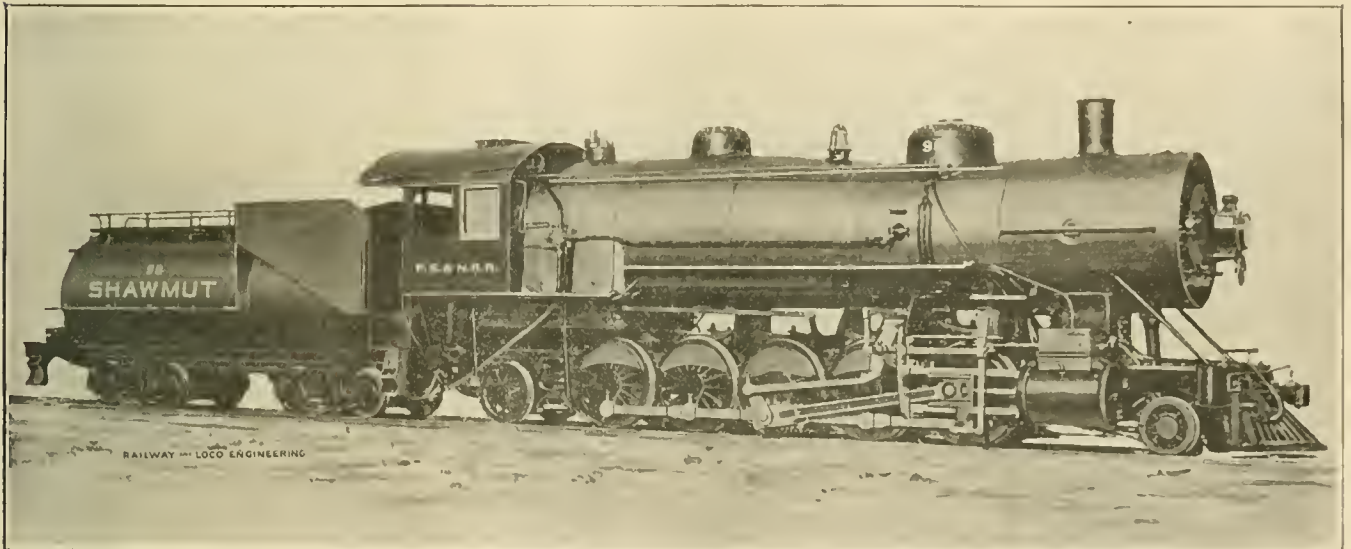

HEAVY 2-10-2 FOR THE PITTSBURG, SHAWMUT & NORTHERN.

R. A. Billingham, Supt. of Motive Power.

Baldwin Locomotive Works, Builders.

x 4 inches, to put under the cellars of the driving boxes, just over the pedestal binders; also, two blocks long enough to reach two ties, and thick enough so that the jacks screwed in, and the blocks would reach within two inches of the underneath part of the back beam of the cab; then to have two small pieces of wood to put on the head of the jack to not let iron be to iron, to avoid slipping. Then jacking was simple, as the engine only had to be barely lifted so she'd spin wheels on a greased rail. But the only reply he made me was to know if there were any more like me left behind out of our family in Ireland."

"As Mr. Dayton cannot contradict you, Mr. Ryan, I'll give him a vacation sufficiently long to permit him going to Ireland to search for more smart Ryans; and, as you have made out your case, proving that you have brain as

ences consist in the use of single expansion cylinders, Walschaerts valve motion and a smoke box superheater. The engine shown in our illustration has cylinders 28 x 32 ins. and with driving wheels 57 ins. in diameter, and a boiler pressure of 160 lbs. the calculated tractive effort amounts to about 59,860 lbs. and with an estimated weight of 235,000 lbs. on the driving wheels the factor of adhesion becomes 3.92.

The cylinders are of the usual form, each being cast in one piece with half the saddle. The Walschaerts gear as applied to this engine actuates balanced slide valves; it is fitted with a rocker shaft having both arms pointing downwards. The rocker shaft bearings are bolted to a crosstie, which is supported on lugs cast in one piece with the upper front frame rails. In this engine the main drivers are the third pair, and they are without flanges, all the other wheels are flanged.

4,586 in the tubes. These tubes number in all 391, they are 2¾ ins. outside diameter, and each is 20 ft. long. The boiler is of the extended wagon top variety 78¾ ins. in diameter at the smoke box end.

In this engine advantage has been taken of the opportunity to economically use superheated steam at a comparatively low-pressure. No change is required in the construction of the boiler in order to accommodate the superheater, which takes the place of the steam pipes in the smoke box. The superheater consists of an upper and lower drum for each cylinder, these drums being connected by curving rows of tubes, which follow the contour of the smoke box shell. The drums are cast steel. The tubes are expanded into tube plates, which are bolted to the drums; copper gaskets being provided in order to make the joints tight. The tubes are divided into separate groups, through which the steam is successively

passed on its way to the cylinders. The heat of the waste gases is thus utilized as fully as possible, for superheating purposes. The heated gases are compelled to circulate among the superheater tubes by means of suitably arranged deflecting plates. Our illustrations show this arrangement; also the position of the netting and petticoat pipes, in the smoke box.

The upper and lower chambers of this superheater arrangement are connected by 288 pipes of 1¼ in. diameter, and these pipes contain in all 352 sq. ft. of heating surface. They do not detract from the flue heating surface of the engine, but with the 29 sq. ft. contained in each of the four cast steel chambers of the superheater make the total heating surface of this device 468 sq. ft. When the heating surface of the boiler is added to that of the superheater the amount comes to 5,264 sq. ft. This is the total amount of heat absorbing surface for water and steam, and is over three-fifths of the area of a baseball field.

The tender is of the Vanderbilt type carried on steel frame. The water capacity of the cylindrical tank is 8,500 U. S. gallons and 14 tons of coal are carried. Some of the principal ratios are as follows: The grate area is 58.5 sq. ft. and the total heating surface (exclusive of the superheater) when divided by the grate area gives one foot of grate area to 82 sq. ft. of heating surface. The fire box heating surface is 4.4 per cent. of the total heating surface. The grate area

Engine Truck Wheels—Back, diameter, 40"; journals, 7½" by 12".  
 Wheel Base—Total engine, 35' 11".  
 Total Engine and Tender—67' 4½".  
 Weight—On driving wheels, estimated, 235,000 lbs.; total engine, estimated, 288,000 lbs.; total engine and tender, estimated, 450,000 lbs.  
 Tender—Wheels, diameter, 33"; journals, 5¼" by 10".  
 Service—Freight.

**Theory vs. Practice.**

Not long ago Mr. W. E. Symons addressed the engineering students at Purdue University at Lafayette, Ind., on the subject of theory and practice. Among other things he said:

"There are two kinds of engineers, the theoretical and the practical, and the man who is both theoretical and practical is better than the other two combined." The theoretical man sits down and works out the mathematical side of some new scheme involving millions of dollars, all of which looks perfectly satisfactory on paper. The practical man comes along, tumbles it all over. He knows that the thing won't work. But the theoretical man is not practical enough to see why it won't work, and if you take his figures away from him he is lost. The man wholly theoretical is exactly the man who is wholly practical, but neither of them is worth considering in a project of any consequence.

It is the happy medium between the two that the student should endeavor

while the technical graduate, in turn, frequently snubs the practical man. The speaker went on to say that the future will be far more exacting to young engineers than the present is. The engineer of the future will have all the dangers which we know of now to contend with, and to these will be added those of the future. He

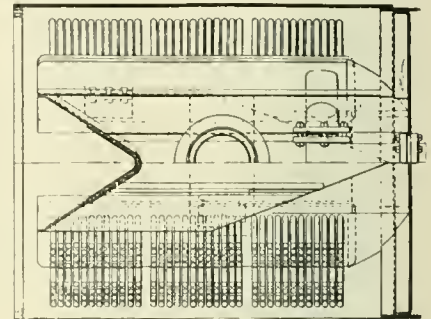

PLAN OF SUPERHEATER.

dwelt on the engineer being familiar with his work and of always being sure he was right. He advised his hearers not to oppose anything unless they had thoroughly investigated the project, and so were in a position to look comprehendingly at all sides of the question. He spoke of the well known case of Dr. Lardner, a noted scientist and engineer, who had in the early days of the steamboat, done much to retard steamboat construction, and practically delayed it for nearly a score of years through his hostility to the idea. This man lacked the qualifications of the finished engineer, which Mr. Symons, quoting from "Ethics of the Engineer," defined as follows: Natural aptitude, proper technical training and proper experience. Continuing, he reminded his audience of the fact that an engineer has to work in harmony with the forces of nature as applied to the uses of man, and that as Victor Alderson has said of the engineer, "no man's errors are so glaringly brought to light as his. The lawyer can fall back on the plea that the judge was biased, or the jury packed; the doctor may perchance bury his mistakes, but the mistakes of the engineer bury him."

The Warren Electrical Manufacturing Company, of Sandusky, Ohio, have purchased the plant and good-will of the Warren Electric Manufacturing Company of that city.

The officers of the new company will be: Millard H. Nason, president, who is also president of the Brilliant Electric Company, Cleveland, Ohio; Frank Warren, secretary, who has been secretary of the Warren Electric Manufacturing Company for a term of years, and Norman L. Hayden, general manager, who was president of the Hayden & Derby Manufacturing Company, New York, and later general manager of the N. L. Hayden Manufacturing Company, Columbus, Ohio.

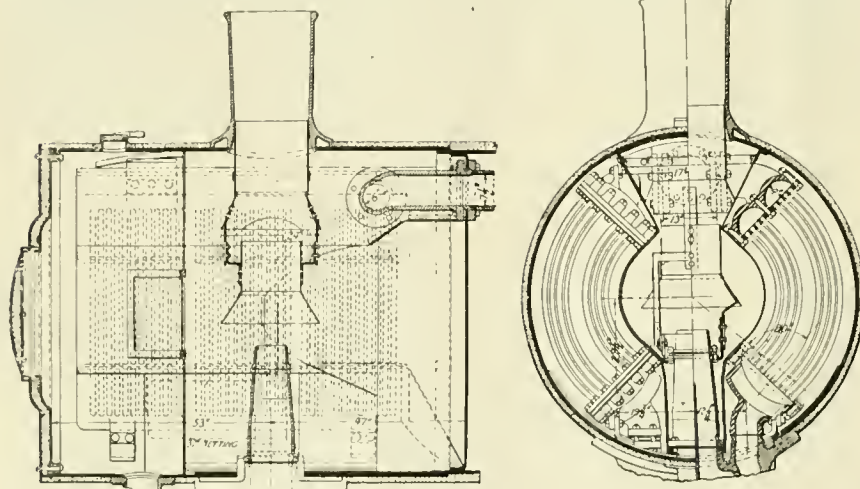

SIDE AND END VIEWS OF SUPERHEATER IN SMOKE BOX.

divided by cylinder volume is 2.57 sq. ft. Some of the principal dimensions are as follows:

- Boiler—Thickness of sheets, 7/8" and 15/16"; fuel, soft coal; staying radial.
- Firebox—Material, steel; length, 108"; width, 78"; depth, front, 80¼"; back, 78¼"; thickness of sheets, sides, 3/8"; back, 3/8"; crown, 3/8"; tube, 9/16"; water space, front, 4¼"; sides, 5"; back, 4".
- Tubes—Wire gauge, No. 11.
- Driving Wheels—Journals, main, 11" by 12"; others, 10" by 12".
- Engine Truck Wheels—Front, diameter, 29¼"; journals, 6¼" by 10½".

to reach. He should either combine his practical work while getting his technical training, or else he should begin at the bottom when he graduates and thoroughly master the practical details of his business.

It is a great pity the technical man and the practical man do not get closer together. There seemed always to be a wide difference between the two. The practical man often takes offence at the dress, language, education and general behavior of the technical graduate,

# General Correspondence

## Walschaerts vs. Stephenson Gears.

Editor:

The introduction of the Walschaerts valve motion has brought out the most singular fact that where two engines of the same class, with the same number and size of wheels, same dimensions as to the cylinders, piston stroke, weights, etc., are engaged in the same service, the engine with the Walschaerts gear invariably develops less tractive power than the other engine of the same class but with the Stephenson link motion; or, in other words, the engine with the old link motion can pull more cars than the engine with the Walschaerts gear can—this referring to heavy freight engines. In heavy passenger service it is generally the case that the difference between the two valve gears is not so pronounced in starting a heavy engine and train, but after a speed approximating twenty miles an hour has been attained the engine with the Walschaerts valve gear has the advantage over the one with the Stephenson motion in steam economy and maintenance of speed.

As the management of a railroad look upon the freight engines as chief revenue producers, however, the fact that the equipment of those engines with the Walschaerts valve gear is reducing the number of tons per train that they should haul is beginning to create an adverse opinion of the merits of Walschaerts' device.

Now, admitting that from a pulling test the engine with the Stephenson link motion proves superior—does that really prove the inferiority of the Walschaerts gear? Maybe we don't quite understand the application of the device, as yet. It certainly is being designed under the theories that govern the application of the common link motion, yet the two systems are radically different.

During the past winter, on one of the leading trunk lines of this country, a competitive test of the two valve motions was made by a committee that was thoroughly equipped for the purpose, and composed of men who were presumed not to be prejudiced beforehand in favor of either principle. The engines used were two heavy, consolidation freight locomotives of the same general dimensions, weight, etc., one having the Walschaerts gear and the other the Stephenson link motion, and the tests included the use of the Indicator and Dynamometer Car.

What did they start out to find, and prove? How could their equipment show the cause of any inequality in the principles of the two valve gears? Well, they did not discover anything inferior in the Walschaerts principle, and only one thing of importance was developed—and it had not been included in their calculations—by the Indicator during the first comparative trips of the two engines, while the reduced tonnage rating of the engine with Walschaerts' gear rendered the Dynamometer car unnecessary.

Several tests were made, at speeds

Walschaerts engine dropped to 165 pounds, while the same pressures of the Stephenson engine only fell to 190 pounds; yet the Walschaerts engine was steaming freely, while on the Stephenson-gear engine the boiler pressure was not kept continuously at the 200-pound mark.

Evidently Egide Walschaerts wasn't to blame. Wire-drawing of the steam somewhere between boiler and cylinders was in evidence, and about all that was gleaned from the tests, from which much was (why?) expected, were the facts just related. Subsequently it was



AVAILANCHE ON A RAILWAY LINE ON THE AUSTRO-ITALIAN FRONTIER.

varying from four and a half to thirty-five miles an hour, and the main showings made by the Indicator were that the engine with the Walschaerts gear suffered a depreciation of steam pressures between the boiler and steam-chest and initial cylinder pressures amounting to 11.5, 12, 13 and 15.4 per cents., respectively, as to the different speeds at the time of testing, while the engine with the Stephenson motion, and approximately the same speeds, the same weight of train, reverse lever in the same notch, and at the same landmarks, during three tests showed losses in steam-chest and initial cylinder pressures of only 1.5, 1.54 and 3.55 per cents., respectively. Both engines carried 200 pounds of steam, and at the higher speeds the average steam-chest and initial cylinder pressures of the Wal-

found that on the engine with the Walschaerts gear the lift of the throttle-valve was not great enough; there were obstructions in the passages between the throttle-valve seat and piston valve seat due to mechanical imperfections in manufacture; a faulty design of cylinder saddle and valve-chest coring produced a form that induced eddy currents and restricted the flow of steam to the steam ports; that the area of throttle-box, stand-pipes, tee-head, steam-pipes and steam passages in cylinder saddle were too small to supply cylinder requirements; that the induction port core entering valve chamber was so enlarged as to equal 3 feet 6 inches increased length of dry-pipe, and producing an expansion tending to materially reduce initial cylinder pressure; a loss of temperature credited to the

traverse of the steam through cavities lying outside of the influence of heat passing through the smokebox.

It would seem that the Walschaerts valve gear on the engine tested had been designed more nearly correct in principle than has been usual, to make so fair a showing as to tonnage hauled as this machine has, in the face of the disclosed facts. I wonder in how many other cases this valve gear has been condemned on account of faulty design elsewhere. The indicator cards taken during these tests will, of course, be interesting, and no doubt will form the subject of a discourse by some one; but what do the cards indicate? Simply the personal theory of the designer of the valve motion in regard to lap, lead and exhaust clearance.

I wish to submit the following propositions to those who are interested in the matter, and who have a fair knowledge of the construction of both the Walschaerts and Stephenson valve gears; it is a fact that different engine designers and motive-power officials have differing beliefs as to what should be the proper proportions of the valve for an engine in any certain class of service; now:

First—If the designer's ideas are incorporated in a valve as applied to a locomotive equipped with the Stephenson link motion whereby the admission of steam to the cylinder begins when the crank-pin is at a predetermined point in its revolution and is cut off at another given point, and the exhaust begins when the crank-pin has reached a calculated position, can not this engine be fitted with the Walschaerts gear and have its valve so designed, and the combination lever so proportioned that the valve's phases will occur identically the same as they did with the Stephenson gear? May not the opening and closing moments be coincidental with both gears? It is a matter wholly determined by the amount of steam lap and exhaust clearance of the valve and the proportions of the combination lever; by working on those features a valve theorist can make the Walschaerts gear give his own pet steam distribution in the cylinders.

Second—If two engines, with the Stephenson and Walschaerts motions, respectively, but of the same general design in all other respects and equally proportioned, can have their valves and valve gear so devised that the steam distribution to the cylinders is the same in both—the opening and closing moments occurring when the crank-pin is at the same identical points on both engines—can there be any reason why one engine should develop a greater tractive power than the other?

When a service change in the cut-off is made by hooking up the engine, then

is the time when the only automatic difference between the two valve gears comes in, in so far as the results obtained are concerned; whatever lead the Walschaerts valve may have had in full gear remains the same when the reverse lever is hooked up—it becomes no greater; while with the Stephenson gear the lead does increase as the increased speed compels hooking up. Instead of this increase of lead being a help to a fast-running engine, as some declare, it may be a detriment, for it can hardly be disputed that most heavy passenger engines with the Walschaerts gear are superior to the Stephenson-gear engines of the same class at high speeds, and the lead of the Walschaerts engines is non-increasing.

Third—With reverse lever in any given notch the steam admission port to cylinder is open while the crank-pin is describing a certain number of degrees of the wheel's circle. Increasing the amount of lead, or decreasing or removing it entirely, will not cause the steam to be admitted to the cylinder for any longer or shorter proportion of the crank-pin travel; the crank will



NEW FRENCH ENGINE AND TRAIN.

receive the steam impulse during the same number of degrees of its revolution, but its zone of power may be shifted and that is all. Lead cannot increase the power.

Fourth—When the opening and closing of the admission ports occur with the crank-pin an equal number of degrees each side from the quarter points (which coincide with a vertical line through the center of the wheel hub) the axle is then receiving the greatest turning force that the piston can give it—the leverage position is true; this correct placing of the degrees of force is impossible when lead exists, with any type of valve gear. Lead thus decreases the power of the crank.

Fifth—With lead opening of the admission port when the crank-pin is on the dead center a certain number of the crank's degrees of force are *annulled completely* as to their turning power, but then exist as a *retarding power*, giving a braking effect between axle and driving-box. *Lead is thus destructive of power.*

Now, for experimental purposes I

should like to see a locomotive valve gear designed without any lead at all—with the valve always one-fourth of a cycle of motion from the piston. That would not be possible with the Stephenson double-eccentric motion, in which it was early learned that the eccentrics would have to be shifted away from their positions normally quartering with the crank-pin, but it would be easily possible with so simple and square a gear as the Walschaerts, which would only require the removal of the combination lever, coupling the radius rod directly to the valve stem, although this would make it necessary to lengthen or shorten the throw of the eccentric, according as to whether the valve was of outside or inside admission.

The design of the valve would then demand most careful consideration; but as the question of the correct delivery by the Walschaerts gear lies wholly within the valve and the doubtful combination lever, and remembering that with but one eccentric, and it exactly ninety degrees from the crank-pin, the valve has a most rapid travel while the crank is near to, and passing, the dead-center points, and that when the engine on one side is on the dead center the engine on the other side is very much alive. It might be well to go back to first principles with the Walschaerts gear and try it out by throwing the whole government of the steam distribution on the valve itself, without any interference from eccentric or crosshead.

There is a strong probability that not one man now alive who is interested in locomotive valve motion has ever witnessed the action of double-connected engines, such as a locomotive, with valves set—and working squarely at all points of cut-off—at exactly ninety degrees of the cycle of motion from the piston and, for reasons stated, it has not formerly been clearly possible. But by using only that portion of the Walschaerts gear that would reduce to first principles the action of the valve, and by substituting different valves with differing combinations in the amount of steam lap and exhaust clearance, some indicator cards—and incidentally some unlooked-for work on the part of the engine—may be expected.

W. W. Wood,

Air Brake Instructor, C. I. & L. R'y.  
Lafayette, Ind.

Mr. Thomas Purvis, who was not long ago appointed superintendent of motive power of the Denver and Rio Grande, is the Purvis mentioned in Skeever's Object-Lessons, and he it was who is responsible for many of the points in connection with shop work which were introduced into those inimitable sketches of "Skinny's" life and career on the Great Air Line.

**Improved Stuffing Box.**

Editor:

I inclose you a blue print of an improved stuffing box for locomotive throttle stems, which can be packed with full steam pressure on the boiler. I have had one of these in use for over a year and have packed the same with full boiler pressure on, in 15 or 20 minutes.

Fig. 1 shows position of stuffing box when engine is in service. Fig. 2 gives

overtook us, and as I was the only passenger and as the train crew were over ahead most of the time, I soon got sleepy, and taking my satchel and making a pillow of it, I stretched myself out on the long caboose seat and went to sleep.

Nothing disturbed my slumbers until the train stopped at a side track called Hopkins, when I was awakened suddenly by a sound like an engine exhausting very rapidly. I was alone in the caboose at the

the third thought that struck me and of the most forcibly was that if I did not get out of that caboose, and that right away, that I would get badly left. And I got. I jumped on the ground and ran about 20 feet and turned around, when the engine hit the caboose and went through it like a shot, and the caboose went into the air, taking with it the smoke-stack, bell, sandbox, whistle, safety valves and cab. Then rolled over onto the ground in front of me.

I saw the fireman jump out of the cab window just before the engine struck the caboose. I also saw the front brakeman hit the ground from the head car, and saved himself.

The engine stopped in the second empty box car ahead of the caboose, a badly wrecked engine.

The train crew, upon hearing the racket, all came running to the scene, and the conductor of the train on which I had been riding was certainly excited, and he fairly yelled, "There is a fireman pinned under this wreck." All hands looked for the fireman, and it was quite a few minutes before I could stop the excitement and show them I was all right and alive.

I have railroaded a good many years, but have never since had anything approaching so narrow an escape.

FRED WHITMORE,

Trav. Eng., Great Northern Ry. Line.

**There Are Others.**

There has been a great deal of talk about car shortage in this country and it

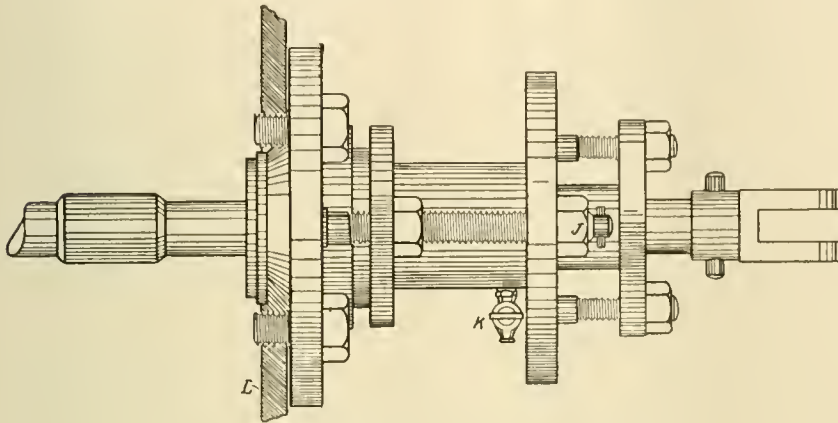

FIG. 1. STUFFINGBOX WHILE IN SERVICE.

the position of the stuffing box while packing is being done. As will be seen, the piece N is forced along stem by nuts J until it seats on B, which shuts off all steam from stuffing box F. After replacing gland C the nuts JJ are screwed out on stud, and steam pressure in boiler forces N to former position. The piece N can be revolved on stem by using a spanner wrench at M, and the seats B and D can be ground.

Hoping this will be of some interest to your readers.

R. L. MOSSMAN.

Medina, Ohio.

**A Close Call.**

Editor:

I once had a very close call, said an old engineer one day, while talking to some friends in the roundhouse.

It was in the early '80's and I was then a young fireman on the Milwaukee road. We had been working on construction all summer on what was then called the H. & D. cutoff, and had about finished the work so that the management had been able to run a few freight trains from Benton Junction to Minneapolis. Things in general had been going along fairly well at the front, as we called it, when one day I resolved to take a lay off and go to Minneapolis and stay over Sunday. All that I had to do was to arrange with the engine watchman to fire my shift, and I, along in the afternoon, boarded a freight train for the East. The distance that we had to go was not very great, but there was a lot of station work to do, so that we got along very slowly. Night soon

time, and being young in the business and also of an inquiring disposition, and at the same time thinking that perhaps the sound came from a train making fast time on the Minneapolis & St. Louis road that paralleled ours only 200 feet distance, I arose and opened the side door of the caboose and looked out to see it go by. There was nothing, however, to be seen

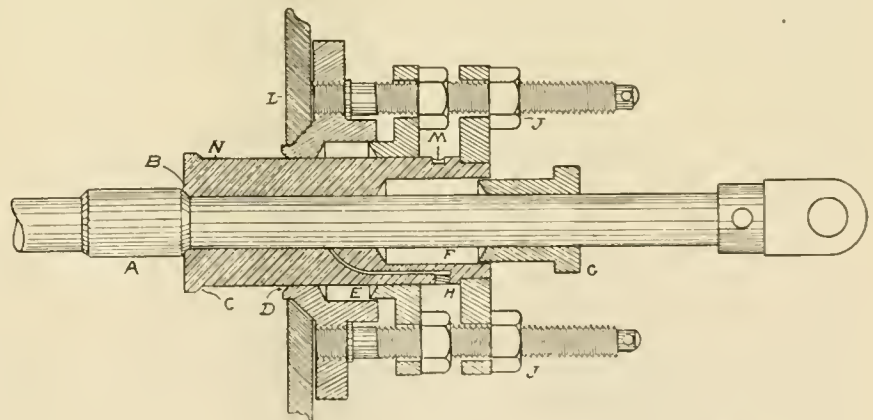

FIG. 2. STUFFINGBOX WHILE PACKING IS BEING DONE.

on their track, and the sound of exhaust still continuing I looked to the rear of our train. This is what I saw. A freight train following us and approaching at a speed of about 30 miles per hour, the engine of which was reversed, was slipping in the back motion frightfully, and not over 150 feet from the caboose in which I was standing. The first thought that entered my mind was that there was to be for the first time in my experience the novelty of a collision. The next thought was that I must see the whole thing, and,

is interesting to learn that "there are others." A recent press dispatch from Vienna sets forth the fact that Austria is suffering in much the same way that we did last fall and during the winter. The dispatch says: "The insufficient supply of locomotives and cars on the railways to the coal fields in the northwestern part of Austria threatens to cause a coal famine in Vienna, where the present stocks are far below the average. The manufacturers of lower Austria and Hungary have suffered great inconvenience

and losses in the past months, through the miserable transportation conditions on the coal lines, and the subject will be brought up at the next session of the Reichsrath. Railroads in Austria are owned and operated by the Government."

**Journal Rolled Out in Service.**

Editor:

I refer herewith blue print of a freak in hot journals, which is somewhat unusual and might be of interest to the readers of your valuable paper. This journal

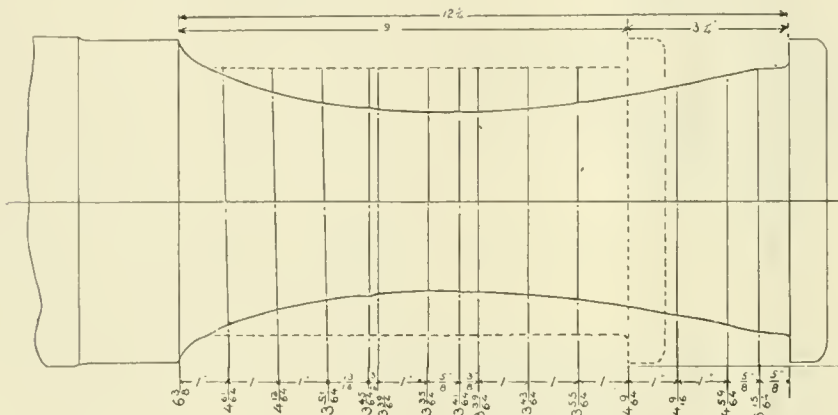

JOURNAL ELONGATED IN SERVICE.

was removed from under a 100,000 pound capacity hopper coal car. You will notice that the size of the original journal is shown in the dotted lines. You will also observe that the journal was rolled out and elongated 2 1/4 inches beyond the original length and reduced from its original diameter from 5 1/4 to 3 5/8 inches in the centre, without showing any fracture, which would seem to indicate a very liberal factor of safety in journals of this size.

W. H. LEWIS,

Supt. Motive Power Norfolk & Western.  
Roanoke, Va.

**Front Flue Sheet Cracks.**

Editor:

The attached sketch shows flanging of front flue sheet. We had an engine here and after doing some heavy boiler work and with flues all in place, the test was put on, and crack developed as marked. I would like to hear from some of the readers of your valuable paper on this subject, to know if they have ever been up against the same kind of trouble after an engine was nearly ready to go out of the shop, and if so, what was done. With my twenty-two years' experience, this is the first case I have ever known.

B. E. GREENWOOD, General Foreman.  
Portsmouth, Va.

**Slipping of Engines.**

Editor:

Referring to my letter, on Slipping of Drivers, in your March number, page 108, the paragraph commencing with the 29th line, should read: "I frankly acknowledge that the slipping can be eliminated by increasing the diameter of the driver; the some result may be secured by closing the throttle, and in either case the tractive power of the locomotive suffers reduction."

The words in italics were dropped from

the article, and I should not care so much for that, but the sense of the sentence is destroyed. Will you kindly correct this paragraph, preferably in your next issue, if possible, as the driving wheel subject generally brings forth more or less con-

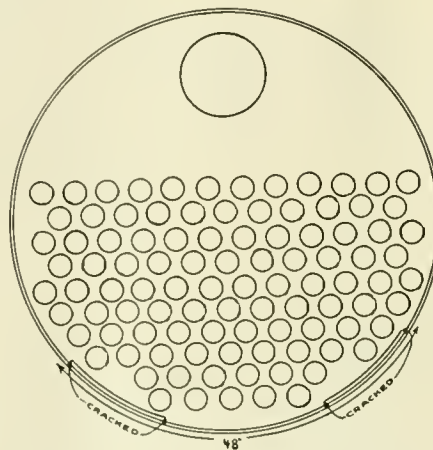

CRACKS IN FRONT FLUE SHEET.

ment, and I am very anxious to be properly understood in what I have to say in regard to it.

T. H. REARDON.  
North Adams, Mass.

**Clamp for Valve Stem.**

Editor:

Attached is a sketch of a valve clamp to use in case one has to disconnect and block the valve. Sometimes a little difficulty is experienced in clamping a

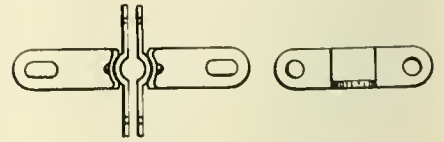

VALVE STEM CLAMP.

valve stem where metallic packing is used on certain class engines, but with this kind of a clamp one can clamp any style. In placing this in position remove one nut off each side of the valve stem gland and place this clamp on the gland, then tighten the clamp round the valve stem after it is in the proper position.

Beaumont, Kan. JOHN F. LONG.

**Packing Nut Lock and Swab.**

Editor:

I inclose a drawing of a combined nut lock and swab that serves as a piston

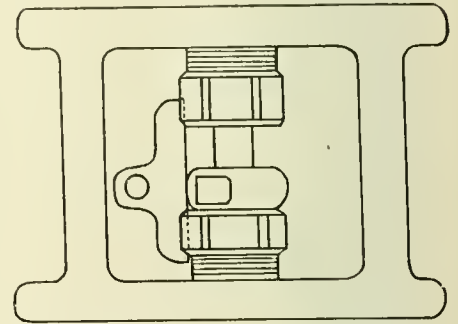

NUT LOCK AND SWAB IN PLACE.

swab, and very effectually locks the packing nuts of air pumps.

The lock, Fig. 1, is made of 1/4-in. sheet steel, and to it is riveted a plate (Fig. 3), slotted at each end to receive swab frame (A); frame is made of 1-32-in. sheet copper 3/4 in. wide. After the frame is wrapped with cotton the lock is placed in the slots of upper and lower packing nuts, the loose end of the

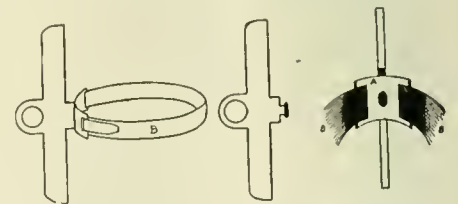

DETAILS OF NUT LOCK AND SWAB.

frame is passed through a slot in plate A and drawn tight and looped over as shown in Fig. B. Fig. 2 shows the packing nut lock and swab holder in place.

J. A. JASSON.  
Corbin, Ky.



**Early Hustle for Steam.**

Editor :

Enclosed please find sketch of a smoke-stack attachment on one of the early Wm. Norris engines on the Pennsylvania State road. It was a sheet iron spiral fan pivoted top and bottom. It would whirl when the exhaust struck it. The idea was to increase the draft. The thing did not live long enough to get green with age. Now these little engines were always hot, as the fuel was good wood and good soft coal mixed. It was in fact a good combination for producing heat, and while the engines had no blowers, the exhaust steam, when the engine was under way, kept the pot boiling. Where I am living now I hear engines every day with three exhausts, but when this spiral fan was in commission the exhausts came out like a string of beads. **WALTER DE SANNO.**

*Fruit Vale, Cal.*

**Model of Puffing Billy.**

This is a full-sized working reproduction of the original engine at the South Kensington Museum in London. The model was taken in hand by a staff of German railway employees after a visit to South Kensington, and facilities for measurement, etc., were given to them by the authorities there. The model is destined for the Munich Technical Museum, being presented by the Union of German Railways, and built in the shops of the Bavarian State Railways at Munich.

**Varnish.**

Tracing the history of modern varnish it would appear that early in the eighteenth century the French people were making varnish from the materials used to-day. These are fossil hard

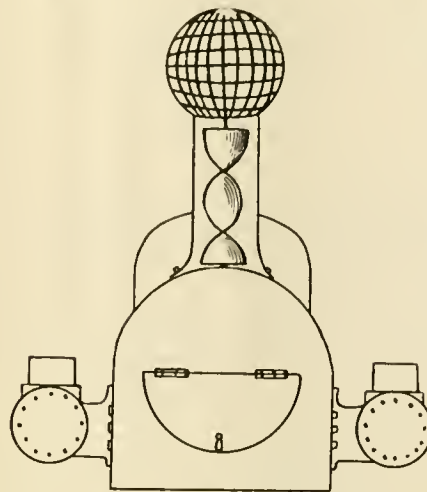

EARLY DRAUGHT ACCELERATOR.

gums, linseed oil and turpentine. The early history of varnish making in London was attributed to a French refugee who had escaped from the French Revolution, and who began to make carriage varnishes about 1776.

Mr. William Marshall, president of the American Locomotive Company, when reading a paper on this subject at a recent meeting of the New York Railroad Club, said of himself: "There

The introduction of varnish making into the United States does not extend back more than a hundred years. A story is told that William Tilden saw a German with a large tray filled with toys, and was attracted by the bright colors and the high luster they presented. He stopped the man and made inquiries, and subsequently hired the man to make varnish at 115 Norfolk street in New York.

In answering the question what is varnish the speaker confined himself to what are known as "oil varnishes" in contradistinction to "spirit varnishes," which are a solution of gums soluble in alcohol or turpentine. He said: "What are known as 'oil varnishes' are those applied to a car, a piano, a table or any piece of furniture. Spirit varnishes are gums soluble in spirits, whereas the gums used in 'oil varnishes' are not soluble in or by oil, but must first be dissolved by heat, which we call melting, before the gum will absorb or mix with the oil. Answering the question, then, 'What is varnish?' It is a composition, or, as Dr. Dudley would say, an amalgamation of fossil resins (which is strictly the name of gum), linseed oil and spirits of turpentine, with a certain per cent. of oxides worked in to serve as driers. This is varnish in general and applies to all kinds, the proportions and treatment varying according to the purposes for which the varnish is to be used. The varnish-maker must make his goods so

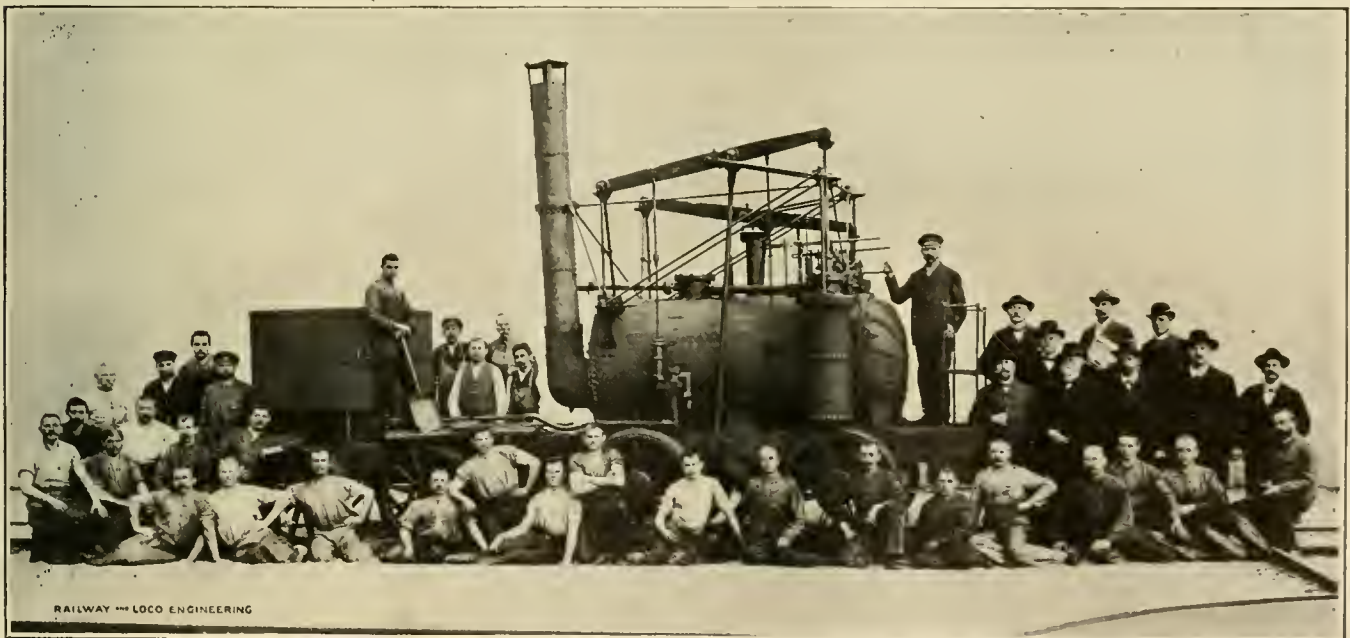

FULL SIZE MODEL OF PUFFING BILLY MADE IN THE BAVARIAN STATE RAILWAYS SHOP AT MUNICH, GERMANY.

An Irish station master sent a telegram to headquarters about a cow which had been run down by a train. It read: "The cow that the down mixed killed yesterday is not dead yet; what shall I do with her? Michael Grady."

are varnish-makers to-day in England who date their connection with the business back to the days of the poor Frenchman, and the writer, although not of the same family, is one who sat at the feet of these Gamaliels."

that they are suitable for outside and inside, for cars, engines, pianos, furniture, interior woodwork, agricultural implements, for air drying and heat drying; for a high polish, like a piano, or to be rubbed to a dull finish; for

metal, for paper, for floors to be walked on and for hardwood ceilings to be looked at. All these and many others require special treatment to adapt them for the purpose required.

"Gum, strictly speaking, is a word only properly applicable to those that are soluble in water, such as arabic, senegal, tragacanth, aloes, etc., all of which exude from live trees, but the gums or fossil resins used by the varnish-maker are petrified, only dissolve under great heat and are the exudations from trees which are extinct. This resinous deposit is found buried in the earth, having lain there, it is stated by geologists, from the period before the creation of man. Different kinds are used for different products, the principle of which are Animi or Zanzibar, Sierre Leone and Benguela; these are found in Africa and the East Indies.

enough to be spread with a brush. When the turpentine has evaporated it leaves the resultant film of gum and oil, which is essentially varnish. Oxides are only used to assist in the drying. The three principal ingredients, gum, oil and turpentine, are vegetable products, whereas the oxides belong to the mineral kingdom and are necessarily a disturbing factor. Some of these are red lead, litharge, umber, black oxide of manganese, borate of manganese, oleates of manganese, sulphate of zinc and sugar of lead. Their mission is by throwing off their oxygen to assist the oxygen of the air to facilitate the drying of the varnish.

Let us go into the shops where we can see in action this "Last Thing Applied but Not the Least Important." In the shop we see cars either building or being repaired. The shop room is limited, only

together. It is only mechanically homogeneous, because it is so finely ground. Now comes the varnish coats. These are the opposite and are supposed to contain a maximum of oil; the absorbent effect of the pigment, which has little, if any, oil in it, is seen when the first coat of varnish is applied, or rather, it is seen the next day, when it presents an all-gone-in appearance, and only begins to look bright and glossy when it has received another coat of itself to hold it up; because this second coat looks better for the time, the work of oil absorption by the color is still going on, and the marvel is that so long a service is secured with any varnish, as now prevails. Varnish would hold its lustre longer and clean up better were it possible to give longer time between color coats and thus permit of some oil being incorpo-



HOOK OF HOLLAND EXPRESS ON THE LONDON AND SOUTH EASTERN RAILWAY.

Kauri, however, is the resin most used; this comes from New Zealand and began to be exported in quantity after the Australian gold discoveries. It is estimated since then up to 1904, \$65,000,000 worth have been shipped, and in that year (1904) \$2,509,085 worth was shipped to the United States and the United Kingdom. In the writer's recollection it used to be shipped unsorted in bags as ballast on sailing vessels and sold in London in the sixties at 2½d. per pound. It now comes all sorted by the natives and ranges from sixty-five cents to about five cents per pound."

Linseed oil is the expressed juice of flaxseed. It is prepared by boiling. All the varieties of varnish are made by the varied proportions of linseed oil and the grade or quality of the gums used. Turpentine is used as a dilutant to render the treated gum and oil, fluid

eight, ten or twelve cars can be accommodated, and the cars are required to be out again and in service as soon as possible. Someone tags each car, stating the class-repair, day it is shopped and the day it is to go out, and all things must bend to the accomplishment of this order. If it is a burned-off car, there will be about nine coats to apply—three surfacers, one guide coat for rubbing, three coats of color and at least two coats of varnish. Up to the day of varnishing every coat is a quick drier; each color coat is a pigment ground in japan, and sometimes two coats are applied in one day. That which counts for durability, the linseed oil, is present only in very small proportions; all preliminary work must be rushed through, and at last we have a surface largely made up of pigments with just enough of binder to hold it

rated, not too much, for that would render a surface unsuitable for varnishing. Oil is the "life blood" both of paint and varnish, and if the paint and color coat does not have its quota, it will be like a sponge, absorb it from the varnish, and to that extent it is giving up its life to another. Here we see the reason why many cars look dull so soon after they have been in service; the varnish cannot keep its lustre; it has all it can do to keep itself together for a time, and soon its parts are weakened, fine checks first appear, then cracks are seen; that which held it together has been stolen; the oil is gone, and now the varnish is found in a resinous, woe-begone and powdery condition. Two causes instead of one have brought about its premature decay. The one unavoidable cause of decay is the wear and tear of the elements,

the sun that drinks moisture from the rivers and ocean also dries out the oil in varnish, and in hot weather is a severe test on the best varnish that mortal man can make.

**Hook of Holland Express.**

The Great Eastern Railway of England have a beautifully equipped corridor dining car train on the Hook of Holland service between Liverpool street terminus in London and Harwich. It excels any train hitherto built for the continental traffic of this company, which has increased very rapidly during the last few years.

The complete train consists of 13 vehicles made up in the order shown in our illustration. A corridor enables passengers to walk from end to end and spacious accommodation is allowed in the compartments, the cars being six inches wider than the standard for main line trains. The restaurant cars have centre passages and the passenger cars have side corridors. The exterior of the train is of varnished teak; the interiors of the first-class compartments are panelled and moulded in walnut relieved with gold lines. The ceilings and partitions above the parcel racks are decorated in white with tinted borders and gold lines. The smoking compartments are trimmed with crimson leather and the non-smoking with blue cloth. The second-class compartments are fitted with dark oak framing, relieved with light oak panels, the ceilings being white, picked out with designs in French gray and gold lines. These compartments are upholstered in crimson and black plush. The train is lighted through-

weighs 382 tons, and has accommodation for 119 first-class passengers and 272 second-class passengers, or 391 persons in all.

The Hook of Holland is the name given to the low-lying beak of land which

All are said to be working satisfactorily, doing fast express work, the heaviest of which is the Hook of Holland Express, a vestibule train with dining car attached. This train is run at a regular speed of 55 miles per hour. The cylinders of the



ROTTERDAM, HOLLAND, LOOKING ACROSS THE OUDENHAVEN RIVER. (Stereograph, Copyright 1904. Underwood & Underwood, N. Y.)

juts out into North Sea at the mouth of the Rhine and the Meuse rivers. The wreck of the Great Eastern Railway Company's steamer "Berlin" recently took place off the Hook of Holland.

We have lately received from a correspondent in Slikkerveer, Holland, a

engine are 18 x 26 ins. and the driving wheels are 7 ft. in diameter. The total heating service is 1201.3 sq. ft. and the boiler pressure is 150 lbs. The engines are fitted with Westinghouse brake, steam sand blast and steam heating apparatus, and are painted green with black borders lined with red.

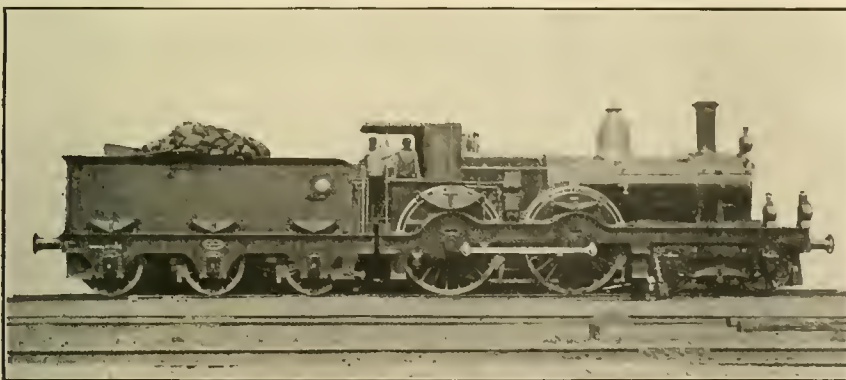

HOOK OF HOLLAND EXPRESS ENGINE ON THE CONTINENT.

out by electricity derived from dynamos on the axles.

The illustration will give an idea of this handsome *train de luxe*, the building of which at the Stratford Works occupied the short period of ten weeks. It has been designed by Mr. James Holden, the locomotive carriage and wagon superintendent of the railway. The engine weighs about 90 tons, and the train measures 653 ft. long over the buffers. The train

photograph of the engine used in connection with the Great Eastern Railway Company's service, between London and Rotterdam. The engine belongs to the Holland Railway Company, and was built at the Sharp, Stewart & Company's Atlas Works in Glasgow. During the past year some engines built by the North British Locomotive Company of the same general dimensions have been used in this service.

**A Varnish-Making Gamaliel.**

"Tracing the history of what might be called 'modern varnish making' as best we can, it would appear that early in the seventeen hundreds the French people were making varnish from the materials used to-day, viz., fossil hard gums, linseed oil and turpentine. There are varnish-makers to-day in England who date their connection with the business back to the days of the poor Frenchman. The writer, although not of the same family, is one who sat at the feet of one of these Gamamiels."

The above is a paragraph from the New York Railroad Club proceedings. The essayist referred to the feet of Gamaliel. Gamaliel was a famous Jewish teacher, who had Paul among his pupils. The essayist on varnish seemed to know that, but the printer and proofreader evidently never heard of the Jewish teacher. They probably thought the reference had something to do with enamel gums.

# Railway and Engineering

A Practical Journal of Railway Motive Power and Rolling Stock.

Published Monthly by

**ANGUS SINCLAIR CO.**

136 Liberty Street, New York.

Telephone, 984 Cartlandt.

Cable Address, "Loceng," N. Y.

Glasgow, "Locauto."

**Business Department:**

ANGUS SINCLAIR, President.  
JAMES KENNEDY, Vice-President.  
JAMES R. PATERSON, Sec'y and Treas.

**Editorial Department:**

ANGUS SINCLAIR, Editor.  
GEO. S. HODGINS, } Associate Editors.  
JAMES KENNEDY, }  
J. P. KELLY, }

**Advertising Department:**

Eastern Representative, S. I. CARPENTER, 170  
Summer St., Boston, Mass.

**British Representative:**

THE LOCOMOTIVE PUBLISHING CO., Ltd.,  
Amen Corner, Paternoster Row, London, E. C.

**Glasgow Representative:**

A. F. SINCLAIR, 15 Manor Road, Bellahouston,  
Glasgow.

**SUBSCRIPTION PRICE.**

\$2.00 per year, \$1.00 for six months, postage paid in the United States, Canada and Mexico. For other parts of the world, \$2.50, or ten shillings. Single copies, 20 cents. Remit by Express Money Order, Draft, Post Office Order or Registered Letter.

Mailing address can be changed as often as necessary—always give old and new address, and if you subscribe in a club, state who got it up. Please give prompt notice when your paper fails to reach you properly.

Entered at the Post Office, New York, as Second-class mail matter.

Copyright by Angus Sinclair Co., 1907.

For Sale by Newsdealers Everywhere.

## Low Centre of Gravity.

There has been a great deal of controversy in various publications concerning the terrible accident to a New York Central suburban train on February 16, at Williamsbridge, N. Y., pulled by two heavy electric locomotives, but we do not believe that any one has identified the real cause of the derailment. Defective track, breakage of running gear and excessive speed have been blamed, but we believe that the inherent want of adaption to conditions in the design of the locomotives caused the accident.

In 1903, a series of experiments was carried out on a military railway between Marienfelde and Zossen, in Germany, for the purpose of testing high speed electric motors. The tests were made under direction of military officers and their report of what was done may be regarded as correct. There were two series of trials. In the first trials a speed of 114 miles an hour was attained, but the locomotives were so destructive to the track that the experiments had to be abandoned until a track could be built of 100 pound rails, laid on particularly strong foundations. With the track thus strengthened, a speed of 125 miles an hour

was attained, but it was noted that the shocks due to the high speed were very severe upon the track.

The designers of electric locomotives have all fallen into the mistake of adopting a center of gravity which is too low.

When the steam locomotive was in course of development, designers labored to secure a low center of gravity and many curious subterfuges were resorted to, for the purpose of harmonizing the conflicting elements of large driving wheels and low center of gravity for the entire engine. Some designers went to the extent of putting the axle of the driving wheels above the boiler, others put the driving wheels entirely behind the boiler. By degrees experience taught designers of locomotives that a low center of gravity entailed a rough riding engine, and one that imparted destructive shocks to the rail.

This experience was by no means confined to the users of pioneer locomotives. Many modern freight engines with small driving wheels are notorious for damaging the track. There is a prevalent belief that consolidation and other multiple coupled locomotives are destructive to track, owing to their heavy weight or long wheel base, but these are not the causes of trouble for most of the many wheel engines carry less weight per axle than eight wheel engines, and the rigid wheel base is seldom excessive. The destructive shocks to the track are due to the low center of gravity which leads the wheel flanges to strike heavy side blows on the rails when inequality of track produces side movement of the wheels.

With a high center of gravity the body of the engine responds slowly to the shocks produced by rough track or by curves; the weight swings slowly and acting through the springs, tends to impart its concussion upon the top of the rail. If an engine or car had its center of gravity on the level of the rail all shocks due to inequality of track would be delivered on the side of the rail. Every developmental movement which raised the center of gravity tended to remove these lateral shocks from the side to the top of the rail, and hence a high center of gravity tends to produce an easy riding engine, and one that exerts little force to spread the rails.

An electric locomotive with the ponderous, unresilient load carried upon the axles will always hammer the track as no other vehicle can do, and the center of gravity being very low, it converts the wheels into huge hammers that exhaust their blows upon the side of the rail. This destructive tendency may be greatly reduced by improved designs, and we think it is

time that the designers of electric locomotives were becoming alive to the fact that their motors demand something more than being made capable of attaining very high speed.

## Safety in a Staple Article.

The number of disastrous wrecks on American railways has focused public attention on the operating department, in which the railroad superintendent is a very conspicuous if not the most important figure. The press of the country has lately been devoting a good deal of attention to Mr. Harriman's utterances, and among the things he is reported as saying at Washington is that in the future railroads will have to be rebuilt with much heavier rails, with a gauge of six feet instead of four feet eight and a half inches. Locomotives of such a size that nobody can now imagine them, or electric engines will have to be provided, and the freight car of the present will have to give way to an all-steel car, and bridges, tunnels, yards and building will have to be made to suit these changes.

Whether one believes that these things will or will not come in time, they refer entirely to road construction and equipments and have very little to do with train operation, except in so far as they provide facilities to work with. The mainstay of the operating department is now and will always be the kind of men who do the work and the discipline maintained on the road, and the responsible officer for these things is the superintendent. Legislation dealing with hours of labor and rest cannot take the place of constant and intelligent supervision nor work a regeneration of the whole system, because it is not possible to force men to rest in the time set apart for rest, and because often the spirit of any law may be evaded while its letter may be complied with, or it is possible that a law may not be rigidly or impartially enforced. We do not mean that legislation in railway matters may not be good, nor do we mean that wisely drawn measures will not bring about an improvement in certain cases, but mere law will not accomplish all that is required for safe railway operation.

Quoting again from the daily papers, Mr. Daniel Willard, vice-president of the C., B. & Q., in charge of operation, is reported to have recently said at Clarinda, Iowa: "Trains are run to-day on practically every American railroad faster than the operating officials in charge consider wise or prudent, and this condition has been forced by the curious idea which many people have that they must go somewhere in a great hurry. The desire for fast travel has become a mania with many, and it is, in my opinion, responsible for many of the recent accidents." While we desire to treat the opinion of so eminent an authority with all the respect possible, we hardly agree with Mr. Willard that it

is the public who are to blame for excessive or dangerous speed. Granting that the public want high speed, it is the railways who actually give it, and they do that not because of any so-called imperative demand of the public, but because fast speed attracts travel, and this means increased revenue for the railways.

If it came to a popular vote concerning fast speed the public would probably vote for it. So it probably would for half-cent-a-mile fare, or seats for everybody, or for more trains. But very cheap fares and greater comfort are not necessarily provided in answer to any vaguely defined demand on the part of the public. If Mr. Willard is correctly quoted, his words form a severe indictment of modern railway methods in general, and of the railroad superintendent in particular. Safety is a standing order placed by the public on the railways now and always, and is, if anything on earth can be, a popular demand, and is a demand which should never be lost sight of or for a moment ignore.

We have before now referred to the superintendent who is capable of giving a good lecture to a new man, but who practically stops at that. The ideal railway superintendent is a man with much the same kind of mind that a construction engineer has, a man satisfied to work quietly, to work steadily, to keep at it, to make progress inch by inch, as the work of driving a tunnel is done. There are many superintendents who work in this way, but there are also a number who do not. On behalf of the superintendent it may be said that he is too often called on for the preparation of statistical or other information for the use of his superior officers, which has a tendency to distract his attention or restrict the time which he has to devote to safe and expeditious train operation and to the steady maintenance of discipline.

Major Charles Hine, of Virginia, addressed the students at McGill University in Montreal not long ago on the subject of modern railroading. Among other things, he is reported as saying that "probably not ten per cent. of the operating officials of to-day ever worked in the train or engine service, or on the track. They come up through one channel or another, and it is a tribute to their ability that they so came up; but the all-round man must be developed." We do not think Mr. Hine's remarks can be intended to apply to the whole country, because it is the rule rather than the exception that those occupying important executive positions on our railways have climbed the ladder of promotion step by step.

The charge against the railway operating officer to-day appears to be not that he is without ability, not that he does not produce results economically, but that in many instances he has let safety become more of an incident than the supremely

important thing to be striven for. The task of maintaining discipline, of following up details, of seeking out the weak spots and applying the remedy, is not easy; it is not dramatic nor spectacular. Like a great deal of well-done railroad work, it is simply hard.

Good equipment is necessary; a reasonable regard for those things which make travel attractive is good business, and the previous training of the man is also important; but standing out prominently above and beyond all other considerations is safety in train operation, not merely as a public demand, but as a duty which is laid upon the shoulders of the operating official. This duty cannot be evaded and the responsibility cannot be delegated. The public may desire this concession or that, the daily press may clamor for this or that innovation, but amid all the fluctuations of the law of supply and demand in modern railroad service, safety is a staple commodity in a rising market, and woe be to the road which permits itself to be caught selling short.

#### Railway Service.

In spite of the dangers attendant on railway service it is attractive to the best class of working men, chiefly because of the regularity of employment. Even in the most prosperous of times the applications for positions in railway service are largely in excess of the number employed. In view of the fact that the building trades are better paid and the hours of labor are shorter, it is nevertheless generally admitted that railway employes are superior in point of intelligence as well as in regularity of habits. Apart from the mere question of wages there is a beneficial effect in steady employment. If the hours of labor are not too long there is nothing that so completely fills up the measure of human existence as constant employment, and there is a variety in railroad work which adds to the pleasure of doing it.

Idleness is not only miserable in itself but it begets other evils. Nothing is more common than to see working men during their unemployed periods frequenting beer saloons and other resorts where their savings are not only foolishly frittered away, but habits are formed that have a pernicious effect on their lives. Young men starting out in life are apt to look upon toil in any form as a necessary evil to be evaded if possible, and borne grudgingly if it cannot be avoided. Envy of the rich occurs only in the minds of those who have not had the opportunity of meeting with the rich and seeing at close range the shallow, frivolous, miserable lives that many of them lead. The rich are not necessarily all of this kind, and as a class they

know little of the substantial satisfaction that comes to the clear minded working men who take a pride in their work and whose daily tasks are ennobled by the unselfish efforts and self sacrifice that look to the welfare of others who may be depending upon them.

In this regard the railway service is largely composed of the best class of men. The regularity of their occupation induces a sober and intelligent regularity of life. The dangers attendant on their work begets a seriousness well calculated to develop the highest qualities of good citizenship. There is a charm in using power in any form and a heightened enjoyment springs from the intelligent guidance of force to the accomplishment of a good and useful end, and the necessary diversity in each day's work makes railroading attractive. It is probable that these are at least some of the reasons why so many intelligent men find congenial employment on our railways, notwithstanding the dangers and the constant petty annoyances which come into the lives of all railroad men. It is not surprising to see and know that a constantly increasing number of railway employes not only own their own homes, but, what is perhaps better, take special care in the education of their children and thereby not only give a good example of a life well spent but lay the foundations of the improved future well being of the communities in which they live.

#### Fallacy About Boiler Explosions.

An experienced engineer telling to a newspaper reporter notes of narrow escapes from being present at boiler explosions, told of finding a man trying to pump water into a red hot boiler which the engineer concluded would have resulted in a disastrous explosion had the cold water reached the hot plates. We would have excused that man if he had not emphasized the claim that he is an engineer of training and experience.

There is a prevalent belief among people, who ought to know better, that should a steam boiler get hot through shortness of water, and feed water be suddenly injected upon the hot plates, an explosion is almost certain to follow. The fallacy of this has been repeatedly demonstrated by experiment in the United States, and several years ago the Manchester Steamusers' Association instituted a series of tests to ascertain the effect upon an overheated boiler of the entrance of cold water, which ought to be widely known. Three tests were made, the boiler plates in each case being heated nearly

to redness. Water was then introduced. In one case the steam pressure rose within a minute from six to 27 pounds, but in the other tests the cold water did not result in increasing the pressure at all. The effect of the sudden change of temperature was to distort the plates and tubes, but no indications of an explosive tendency were found.

In connection with these tests, some experiments described by Mr. Coleman Sellers long ago at a meeting of the Railway Master Mechanics' Association will be of interest, for boilers are liable to act to-day as they did then. He said: A locomotive, which was condemned and had been condemned to be taken to pieces, was run out on a side track off from Altoona, in the woods, and they determined to try an experiment which they had always desired to see tried, namely, the firing of a boiler until the steam was very high, then blowing it out so as to expose the top of the crown sheet, and allow it to become red hot, and with a large fire engine force water into that engine. They fired it up and retired to a safe distance. They saw the pressure gauge go up to 125 pounds; then the lock-up safety valve blew off, showing it was not weighted heavily enough. They had no means to determine, except by guess, and retired a second time, thinking they could then go on with the experiment as they intended, but they had hardly gone from the boiler—they were not five minutes away from the boiler when the pressure gauge hand seemed to run as rapidly as anything could until it reached something near 200 pounds, when the engine blew to atoms. It was full of water, with every condition that would insure safety, except that the pressure was a great deal too great for the strength of the material composing it. No other reason could be given for the explosion.

They then took a second engine and treated it in the same manner, but that one happened to be strong enough to sustain the pressure they desired. They blew the water out, and when the glass gauge indicated that it was below the crown sheet to be red hot they pumped water into it and in pumping in it behaved as I had seen it do in other cases. The steam merely went down. Once or twice or three times they repeated it. The boiler was injured by the fire, but it did not explode or do any harm to inject large quantities of cold water into the very much heated boiler.

In other experiments made at the Harrison Boiler Works with cast iron boilers, many gentlemen present, representing a Committee of the Franklin Institute, were anxious to see this experiment of a red hot boiler having

water suddenly injected into it tried with a cast iron boiler. They had already fired one of them up to a pressure of 170 pounds. One of these same boilers was fired up to 150 pounds, the blow-off cock was opened, and the whole of the steam discharged. We waited ten minutes, and heated the furnace so that a stick of wood put against the boiler would immediately become ignited, and we injected the water in. But, instead of making steam, it cooled off the boiler. We waited for steam, blew it off again, and three times we repeated that experiment, and during that whole time I was standing within five feet of that boiler, with my hand on it most of the time, and it behaved just exactly as a mass of iron of that size should behave; that is, the water passed into it, merely cooling off the iron and doing nothing else. The experiment was very interesting and was very conclusive that the whole mass of the boiler, if heated red hot, does not contain heat enough to raise the water in the boiler up to the steam point.

#### Block Signal Report.

The Interstate Commerce Commission have under the direction of Congress investigated matters connected with accidents on American railroads, for the purpose of reporting to that body. In the report just issued, on Block System Signals and Appliances for Automatic Control of Railway Trains, there is a great deal of very valuable information and much food for thought.

In the appendix which gives the casualty list of employees killed and injured for the years 1902, 3, 4 and 5, we find that in Great Britain there were 4, 9, 7, and 6 employees killed respectively in those years, making a total of 26 killed, while the totals for the same years in the United States are 654, 825, 749, and 715, or a total for those four years of 2,943. For every one employee killed there, we killed 113. The proportion of injured is not so high, but it is bad enough.

Statistics like these show fluctuations with good years and bad years for both countries, and statisticians will probably draw all sorts of conclusions therefrom, but there is one very plain and very sad fact apparent through it all, and it is that though we have a greater mileage than the United Kingdom, and with not so dense a traffic as they have, yet by reason of railroad accidents we nail down the coffin lid over the dead faces of many more people than they do in Britain, and there is a cause for it that we are quite competent to get at and remedy if we determine to do so.

Many roads here make as good a record as any across the water, and the insistence that the average of performance here be

raised all round is not like crying for the moon, the attainment of safety is a thing which can be done, is done by some and ought to be done by all.

In dealing with the subject of block signals the report says that: "There is no escape from the conclusion that the block system is the best known instrumentality for the prevention of collisions, notwithstanding the imperfections which have been shown in the results of its operations, and that the highest standard, both of the public requirements and of expert railroad opinion, call for its general use. The most progressive railroads are using the system extensively and are extending it, and their signal engineers and operating officers are constantly striving to make it perfect."

Further on in the report we find that in the two years from July 1, 1904, to July 1, 1906, there were a large number of butting and rear collisions. Of these 13 were on lines worked by the telegraph block system. In the same two years there were 7 other rear end collisions on lines operated under automatic block signals, due to engineers passing signals indicating stop. These accidents appear to be sufficiently important to be given in detail. In such cases there is a strong presumption that laxity of discipline is one, if not the principal cause of the trouble.

The La Follette law passed at the last session of Congress is designed to prevent overwork on the part of employees engaged in train service. The report of the Interstate Commerce Commission concerning the block system shows that there is a desire to provide a remedy for the evils which have grown up in railroad service. It is to be noted that the legislative remedy comes from the outside, and the fact that a remedy is proposed by those not immediately connected with railroad work argues that there has not been any comprehensive or effective attempt to improve conditions by those railroad officers whose duty it was to have made safety the first consideration in carrying on the work of handling traffic; a work which they are daily engaged in, year after year.

If the large number of railroad accidents are the result of the system employed, it is no great stretch of imagination to see that the system must be at fault, and that so far it has not been very greatly improved from within. The idea of always laying the blame on "the men" has not been productive of much good.

In case of naval and military disaster the court martial directs its attention to the commanding officer, and where laxity of discipline is the real underlying cause of the trouble he is held responsible. The application of the military idea of responsibility would do a great deal of good in transportation matters, and a way should be found to empower the Interstate Commerce Commission to investi-

gate and definitely place the blame for every railroad disaster which occurs in this country and the remedy should be applied by order of the Commission.

### Judging and Knowing Speed.

There has been more or less discussion from time to time as to the ability of the locomotive engineer to judge speed, and it is pretty generally admitted that the steam locomotive engineer has done well in the matter of judging the speed he may be traveling, at any particular moment. When it comes to the judging of speed the man in charge of an electric locomotive has not exactly the same chance to form an estimate of speed. In the electric locomotive there are no exhaust beats, and there are in this country at least no outside rods or moving parts to look at, and there are many things absent on an electrically driven machine, which are noticed in connection with a steam locomotive and which help the steam locomotive man to tell about how fast he is going.

In the Simplon tunnel there are definite spaces measured off and set with appropriate mechanism, with which the passing locomotive makes electric contact, and, so to speak, registers its own performance. On the Continent the practice is to have some sort of speed recording device on most of the steam locomotives hauling important passenger trains. The application of a speed recording and speed indicating device to electric locomotives ought to be part of their regular equipment.

In this matter the Chicago, Burlington & Quincy have shown a determination to have reliable information in regard to actual speed. This road has now over a hundreds speed recorders in use on their locomotives hauling passenger and mail trains. They use the Boyer Speed Recorder, made by the Chicago Pneumatic Tool Company.

These recorders are applied to the engines over the front truck and are belted to an axle pulley on the outer end of the front truck axle. By means of a fine tension wire, the movement of the recorder is transmitted to a speed gauge in the cab. This gauge is placed in front of the engineer so that he can see at a glance just what speed in miles per hour he is making. In addition to thus indicating in the cab the rate of speed of the locomotive, a permanent record is made on a paper tape in the speed machine. This tape is removed at the end of each round trip for future reference.

With this apparatus on the engine there is no excuse for exceeding any prescribed limit of speed and the indicator has been found very convenient for engineers when given a slow order for any portion of the road.

### The Injector.

The degree of perfection attained by the working of the injector is such that it, almost passes unnoticed in the category of devices attached to the modern locomotive. Barring impurities in the water supply the injector performs its functions with a freedom from irregularities that is in marked contrast with many of the other accessories of the steam engine. Like Watt's condenser it is one of the very few inventions that sprang into being fully equipped, and the subsequent improvements have added little to its qualities or to its utility. It was a peculiarly bright and daring thought of the French engineer, Henri Giffard, who conceived the idea of forcing water into a boiler against the same pressure which was used to carry the water, and yet this seeming impossibility is not only feasible but the injector will force water into a boiler against a higher pressure than the steam used by the injector.

So effective and so quiet is the work of the injector that the immense power it exerts is seldom taken into consideration. The larger kind of injectors will force 75 gallons of water per minute into a boiler. The amount of steam required in working the injector is also greatly in excess of what is generally supposed. It is safe to assume that an average of one-eighth of the entire volume of steam generated is used in operating the injector so that in the largest locomotives something over 100 h.p. is probably used in keeping up the supply of water. Shutting off the injector on approaching a grade adds much to the power of the engine, and it is also a saving of steam to work the injector while the locomotive is standing.

### Book Notices.

**Air-Brake Catechism**, by Robert H. Blackall. Published by the Norman W. Henley Publishing Co., New York, 1907. 375 pages, with numerous engravings and folding plates. Price, \$2.00.

This is one of the standard works on railway mechanical appliances and in its own department meets every requirement. The fact that this is the twenty-first edition is sufficient proof of the popular approval which has crowned the laudable efforts of Mr. Blackall to place in the hands of railway men a work that meets the growing requirements of all who are in any way connected with the application of air brakes in railway operations. The author and publishers have the fine sense to realize that an edition of such a work cannot continue to meet the requirements of the expanding use of the air brake for any considerable length of time, and the intelligent enterprise they show in constantly keeping the book abreast of

the times is praiseworthy. The new edition fully meets all the changed conditions of service which now prevail, particularly in the matter of cars of heavier capacity and locomotives with an increased power and weight equal to their increased duties. A valuable appendix to the book has been added with a view of explaining the operation of the newest equipment, and it is absolutely necessary for railway employees to become familiar with the complex mechanism necessary in the effective use of the air brake. The book is sure to meet with increased favor among railway men.

**Modern American Lathe Practice**, by Oscar E. Perrigo, M.E. Published by the Norman W. Henley Publishing Co., New York, 1907. 416 octavo pages, 314 illustrations. Price, \$2.50.

This is one of the best books of the year and in its particular branch is one of the most complete works on mechanical appliances that we have had the pleasure of examining. In its pages the history and designing of lathes are thoroughly discussed, and the classification of lathes is taken up, giving the essential differences of the several types of lathes, including a special chapter on electrically driven lathes. The book is written in a clear and interesting style and every page shows how thoroughly the author has mastered his subject. It has the merit of representing the very latest practice in lathe operations as well as the construction of lathe tools. The engravings have been specially made for the work, and the book is in every way a fine example of the printer's, illustrator's and binder's art.

**The Railroad Pocket Book**, by Fred H. Colvin. Published by the Derry-Collard Co., New York, 1907. Flexible cloth. Price, \$1.00.

This book has been a popular favorite with railway men, and appears this year with many marked improvements that are sure to meet with a warm appreciation. The book was originally intended to give such information as is constantly called for in different branches of railroad service. The information is alphabetically arranged and is presented in condensed form. The arrangement of matter renders the use of an index as unnecessary, and it is surprising how much valuable information the work contains in compact form. The book is neatly printed and the rounded corners fit it admirably for the pocket. Its growing popularity is assured. The author modestly states that errors will be gladly corrected. In his next edition he should state that Egide Walschaerts, the inventor of the valve motion that bears his name, was a native of Belgium, and not Germany, as stated.

# Patent Office Department

**SUPERHEATED LOCOMOTIVE BOILER.**

Mr. H. O. Keferstein, Brooklyn, N. Y., has secured a patent for superheated boilers. No. 837,844. The boiler consists of three drums with connecting tubes and superheater coils. The

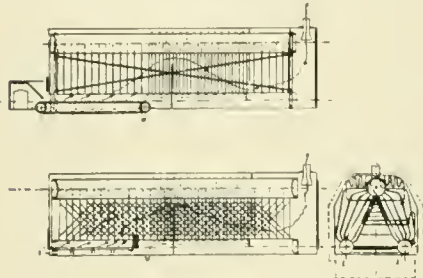

WATER TUBE BOILER.

upper drum may have a diameter of 36 ins. and the middle drums of 30 to 24 ins. There are about 20 connecting tubes 2 ins. in diameter. The superheater coils are 1 in. in diameter and directly connected with the upper drum. Sliding or rolling dampers are arranged between boiler tubes and superheater coils in order to regulate the steam temperature in an easy and regular way. The advantages claimed are lighter weight in boilers and cheaper price with a large saving of coal, while a pressure of 300 lbs. is perfectly safe with a boiler so constructed. The inventor is a well-known mechanical engineer and expert in boilers.

**LOCOMOTIVE EXHAUST NOZZLE.**

An exhaust nozzle suitable for locomotives or other steam engines has been patented by Mr. J. B. Allfree.

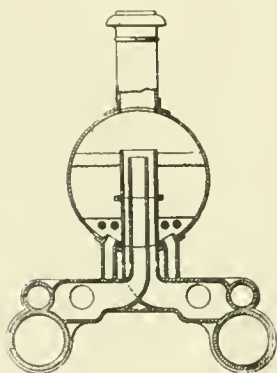

ANNULAR EXHAUST.

Ironton, Ohio. The device embraces an exhaust nozzle in the smoke box and comprising an inner cylinder, an outer annular and concentric cylinder surrounding the inner cylinder and forming therewith a uniform unob-

structed annular exhaust passage, the upper edge of the outer cylinder being above the edge of the inner cylinder, and means for connecting the passages formed by the inner and outer cylinders with the exhaust of the engines.

**FLUE CLEANER.**

Mr. G. C. French, Chicago, Ill., has patented a flue cleaner. No. 844,928. As is shown in the accompanying illustration the device comprises a central bar, a scraper mounted upon the bar consisting of a double spiral spring having coils of substantially uniform diameter and provided with eyes formed integral with the spring adapted to engage the

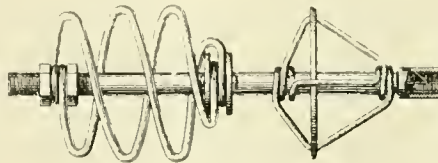

FLUE CLEANER.

bar. There is also a follower mounted upon the bar apart from the spring, and guide rods extending from the edge of the follower to the bar.

**DOUBLE-CRANK JOINT.**

An improved double-crank joint has been patented by Mr. W. L. Morrow, Stockton, Cal. No. 843,090. The device comprises a connecting rod with a semi-circular brass bearing and a second connecting rod fitting between the furcations of the first rod, a semi-circular brass bearing carried by the second

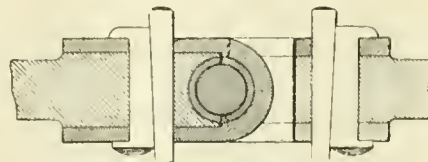

DOUBLE CRANK JOINT.

connecting rod, the outer faces of the second connecting rod bearing against the inner faces of the furcations of the first rod, thereby forming a bearing for the outer faces of the second rod, and keys for tightening each of the connections on the crank or shaft.

**SMOKE CLEANER.**

Mr. J. Roesser, Baltimore, Md., has patented a smoke-cleaning and cinder-catching apparatus adapted for use in locomotives. No. 846,052. The device comprises a boiler and smoke chamber with a partition separating the chamber into two compartments and forming a flue connecting the two com-

partments. In the first compartment the smoke is acted upon by a jet of steam for the purpose of partially washing out the carbon and other visible matter in the smoke and also directs the smoke into the second compartment where the exhaust steam pipe

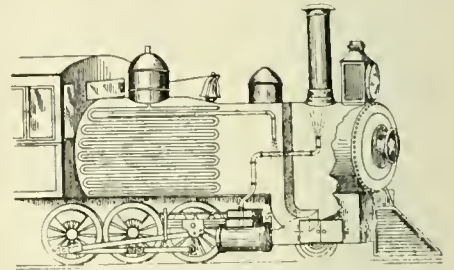

SMOKE STACK CLEANER.

is located and is provided with a jet on the free end and discharging within the second compartment and completes the washing-out process and precipitates into the bottom of the compartment the carbon and other matter where adjustable openings are arranged to draw off the accumulated matter from time to time.

**JOURNAL BOX LID.**

Mr. A. Lipschutz, St. Louis, Mo., has patented an improved journal box lid. No. 845,800. The journal box lid is provided with a hood, a leaf spring secured to the inside of the lid below the lower end of said hood and projecting into it, the hood having a wall which forms a closure for a portion of the hood, and is imperforate above the

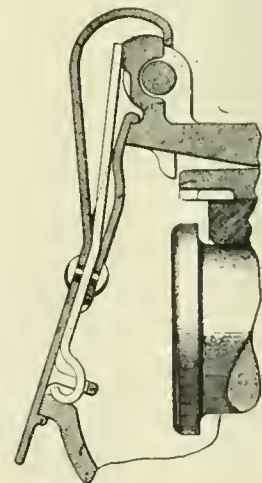

JOURNAL BOX LID.

point where the spring is secured to the lid and terminating below the point where the spring is connected to the lid.



# Correspondence School

**Third Series—Questions and Answers.**

280—How do you understand an order reading: "No. 1 display signals Somerset to Oakdale for engine 85?"

A.—If I were engineer of No. 1 would display signals from Somerset to Oakdale, indicating that a section was following. If I was on engine 85 I would not display any signals.

281—How do you understand an order reading: "2nd No. 31 display signals Oakdale to Boyce for 3rd No. 31?"

A.—Under this order Second No. 31 will display signals from Oakdale to Boyce. Third No. 31 will not display signals.

282—How do you understand an order reading: "Engines 580, 585 and 590 run as 1st, 2nd and 3rd sections No. 1 Ludlow to Somerset?"

A.—Under this order engines 580 and 585 will display signals from Ludlow to Somerset. Engine 590 will not display signals.

283—How do you understand an order reading: "Engine 585 is withdrawn as 2nd No. 1 at Junction City, following sections change numbers accordingly?"

A.—Under this order engine 585 after arrival at Junction ceases to be the second section of No. 1 and drops out. The sections following will take the next lower number.

284—How do you understand an order reading: "Engine 577 will run as an extra passenger train, leaving Chattanooga on Thursday, Feb. 17th, on the following schedule, and will have the right of track over all trains: Chattanooga, leave 8:00 A. M.; Dayton, leave 9:10 a. m.; Rockwood, leave 9:50 a. m.; Oakdale, leave 10:15 a. m.; Somerset, arrive 12:55 p. m.?"

A.—Under this order the schedule for engine 577 as extra passenger train is made for Thursday, Feb. 17th, and must be obeyed by engine 577. All other trains must respect this schedule and clear the time of the extra by the time specified in the rules.

285—How do you understand other trains would be governed with regard to this extra passenger train?

A.—All other trains must run with full regard to this schedule, and clear the time of this particular extra passenger train by the time specified in the rules.

286—Must trains in yard limits be protected against such trains.

A.—Answer according to special rules of your railroad.

287—How do you understand an order

reading: "Engine 599 run extra, Greenwood to Helenwood?"

A.—Under this order engine 599 would carry white classification signals from Greenwood to Helenwood because it is a train not represented on the time table.

288—How do you understand an order reading: "Engine 581 works 7 A. M. until 6 P. M., between Danville and Burgin?"

A.—The work extra must, whether standing or moving, protect itself against extras within the working limits in both directions as prescribed by rule. The time of regular trains must be cleared.

289—How do you understand an order reading: "Work extra 422 protects against extra 225, south, between Burgin and Donville?"

A.—Under this order work extra 422



STATION AT BASLE, SWITZERLAND.

must protect itself against such trains, as indicated in rule 99.

290—What would you do if running the extra train?

A.—If running extra 225, would proceed expecting to find the work extra protecting itself between Burgin and Danville.

291—How do you understand an order reading: "Work extra 422 has right over all trains between Junction City and Moreland, 7 P. M. to 12 night?"

A.—This gives the work extra the exclusive right to the track between Junction City and Moreland between the hours named and need not protect.

292—How do you understand an order reading: "Engine 234 works 5 P. M. to 10 P. M. between Holcar and Fortescue, protecting against westward extras?"

A.—Under this order the work extra will protect itself only against westward extras during the period of time specified. The time of regular trains must be cleared.

293—What would you do on an order reading: "Extra 576 will protect against work extra 595 between Evansville and Dayton?"

A.—If on extra 576, I should receive a copy of the work train's orders, and would protect myself as per rule 99

against the work train between Evansville and Dayton.

294—Do you understand that a work train, when overtaken by an extra, should let it pass without unnecessary delay?

A.—Yes.

295—How do you understand an order reading: "Work extra 595 between Barren Fork and Whitley protects against No. 10?"

A.—Under this order the work extra may work upon the time of No. 10, but must protect itself against No. 10 as per rule 99, and No. 10 will run expecting to find work extra 595 protecting itself.

296—Suppose you had an order reading: "Work extra 595 protects against regular trains, and no regular trains due, do you consider it would be necessary to protect your train in each direction?"

A.—No, because a regular train must not run ahead of its schedule, and under these circumstances no other extra shall be authorized to run over that portion of the track without provision having been made for it to pass the work train.

297—When an operator presents you an order reading: "Hold all trains." What should the conductor and engineer do?

A.—They must receive copies of the order from the operator. The order should be addressed to him. They must obey the order as if addressed to them.

298—When may a train holding this order proceed?

A.—A train holding this order may proceed only after receiving an order specifically authorizing its departure, as "No. 10 may go," or until an order has been received annulling the holding order.

299—How do you understand an order reading: "No. 1, February 29th, is annulled, Gobles to Brightwood?"

A.—The schedule of train No. 1 between Gobles and Brightwood becomes void and cannot be restored.

300—In case the train is only annulled between Chattanooga and Oakdale?

A.—The schedule existing between those points only, becomes void.

301—When a train has been annulled, can it be again restored under its original number?

A.—No.

302—If you received an order reading: "Order No. 53 is annulled," how would this affect order No. 53?

A.—It would make order No. 53 void, and its effect would be as if it had not been issued.

303—Should an order be received that trains 1 and 2 would meet at Eubanks,

and it was afterwards found necessary to change the meeting point to Kings Mountain, how should the order changing the meeting point read?

A.—The order would be of the form, "No. 1 meet No. 2 at Kings Mountain instead of Eubanks."

### Gearing Up a Lathe for Screw Cutting.

By FRED H. COLVIN.

Having found the depth of threads and the size drill to use or hole to bore, we naturally come to the old but ever new question of gearing up a lathe to cut any thread within its capacity. This capacity is limited by or depends on the gears it has.

There are many new lathes where the gear problems are cut out by a gear



COMING ALONG FAST.

box, where you simply move a handle to any thread on the index and you get just what you want, but there are still hundreds of lathes without this, and the question remains open just the same.

The first thing to do is to find out the lead or pitch of the lead screw and whether it is "geared even" or not. In other words, does the spindle and lead screw each make one revolution in the same time. If they do, then we are started right, and have no further complications, except to find the gears.

If they do not, we must find the "equivalent" lead or pitch by putting on even gears, say, a 36 on both lead screw and spindle, and see what thread it cuts on any piece of metal. This is the "equivalent" pitch of lead screw, and what we have to reckon with.

If the lead screw has four threads to the inch and it cuts a 4 thread, it is geared "even," but if it cuts an 8 thread it is geared "two to one," and 8 is the equivalent thread, and the one we must use in our calculation.

You can arrive at this same conclusion by figuring the gears between the spindle and lead screw, but it is a whole lot easier to cut a thread and it avoids all the mistakes that might creep in. But be sure and put even gears (no matter what number of teeth, so they are alike) on both spindle and lead screw.

Having found that the pitch of lead screw to be considered is 8—either be-

cause it is geared even or from cutting a thread on a piece of metal—we are ready for business.

Suppose we want to cut a 4 thread. Isn't it clear that, as the lead screw will cut an 8 thread when geared even, that it must be made to move twice as fast as the spindle to cut a 4 thread, because a 4 thread is twice as fast a pitch as 8 threads?

Now, we know that if we drive a 12-inch pulley with a belt from a 24-inch pulley on the line shaft, that the 12-inch pulley will make twice the number of revolutions that the 24-inch will. This is simply because the distance around the 24-inch pulley is twice that of the 12-inch, and it must turn twice while the other is turning once.

It's the same with gears.

So, if we put a 48-toothed gear on the spindle and a 24 on the lead screw we know it will turn twice as fast as the spindle, and consequently must cut a 4 thread.

If you want a 16 thread you simply reverse these gears, because 16 is only half as great a pitch as 8, and the screw must turn half as fast as the spindle.

We see from this that when the thread to be cut is finer than the equivalent lead screw pitch, the larger gear goes on the lead screw, but when it is coarser, the larger gear goes on the spindle. This precaution is given because the writer has seen good work spoiled by the lathe man putting the gears on wrong. He had figured them out right, but had not stopped to think which should go in the spindle.

Suppose we want to cut a 7 thread. We could go through a lot of calculations and show what relation they bore to each other, but it isn't necessary.

Just take your thread to be cut and the pitch (equivalent lead) of lead screw and multiply them both by any number, no matter what number so long as it gives you gears that you have on hand.

This gives us 7 and 8. Multiply these by 4 and we get 28 and 32. As the thread to be cut is faster than the lead screw, we put 32 on the spindle and 28 on the lead screw, which shows that the gear obtained by multiplying the thread to be cut always goes on the lead screw and that obtained by multiplying the pitch of the lead screw always goes on the spindle.

Instead of multiplying by 4 we could take 3, 5, 6, 7, 8, or any number; but multiplying by 3, 5 or 7 gives us 21, 35 or 49 for one gear, and we are not apt to find odd toothed gears in a lathe set. So it is usually best to take even numbers and as low as possible. It's a good plan to try 4 first, as it usually works out.

Here is a 13 thread to cut, what are the gears?

Multiplying both 13 and 8 by 4 gives 52 and 32, both even and likely to be in the set. If not try 6 and get 78 and 48, and so on, until you get it if there are gears there, which is not always the case.

Suppose you want to cut 11½ thread, which is a standard pitch for pipes from 1 to 2 inches, inclusive. Most lathes have gears to cut this, but all do not.

Multiplying 11½ and 8 by 4 we get 46 and 32, which all lathes do not have, but in one case I knew there happened to be a 23-toothed gear. So the machinist threw in the compound gear, which reduced the speed of the lead screw one-half with reference to the spindle, put the 23-toothed gear on the lead screw instead of 46, and went ahead.

Quick pitches do not often occur in railway work, but you may want to know how to handle them just the same, so we assume a special screw with 1½ threads to the inch. We cannot multiply by 4, as we have no gear less than 24, as a rule, so we multiply by 16 and get 24 and 128. If you have 128, this lets us off easy, but the chances are you haven't, so the compound gearing comes in again, this time reversed, so as to move the lead screw twice as fast as the spindle.

This practically makes the lead screw 4 instead of 8, so we multiply over again and get 24 and 64, which we have and our troubles are over.

Compound gearing is usually 2 to 1 in., so as to either reduce the equivalent pitch one-half, or double it, depending how it is used. This makes the pitch



GOING, GOING, GONE.

equivalent to 4 or 16, as the case may be, and you can figure from that basis. If any other compounding is used, such as 3 to 1 (which would be awkward in most cases), or 4 to 1 (which is very seldom needed), proceed in the same way.

So, when we come to look into the heart of screw cutting it is very simple, if we only grasp the principle and it is this which I have endeavored to make clear.

As in all sorts of calculations, and in mechanics generally, it is necessary to reason things out as we go along, and if this is done you will have no trouble in cutting any thread the boss wants, providing you have the gears for it.

## Questions Answered

### LENGTH OF STOPS.

(32) W. C. C., Elmira, N. Y., writes: About how far should it take to stop a passenger train going fifty miles per hour with the high-speed brake, and how far would it take for eighty miles per hour? A.—It all depends on conditions. At the Atsion tests made in May and June of 1903 with a test train consisting of an engine and six cars fitted with Westinghouse high-speed brakes, in first-class condition, stops were made on a level track from a speed of sixty miles per hour in 976 feet, and from a speed of eighty miles per hour the train, consisting of an engine and three cars, in 2,029 feet. With average conditions of train brakes, however, it would require a little greater distance than that given above.

### OPERATING EXPENSES.

(33) R. P. G., Field's Landing, Cal., asks:

What is considered a fair percentage of operating expenses for the maintenance of equipment? A.—The mechanical department of a railway is like the public works department of a government, it spends the most money. As a rough approximation, the percentage of expenditure for the maintenance of equipment, taking into account ordinary betterments without including new engines and cars is about from 40 to 50 per cent of the total outlay. When getting at these figures a good deal depends on the way the accounts are kept.

### FIREBOX AND SMOKEBOX TEMPERATURES.

(34) J. N. E., Decatur, Ill., asks:

(1) What is the temperature in the back and front ends of the firebox? A.—No very accurate experiments have been made to determine the temperature of the different parts of the firebox. The temperature of the fire in a locomotive firebox, when in a state of active combustion, as when the engine is working hard, is probably from 3000° to 4000° Fahr. (2) What is the temperature in the front end, with length of flue 16 feet 4 inches? A.—Experiments which have been made have demonstrated that when working at maximum capacity a probable temperature of 675° Fahr. exists in the smokebox of an engine. (3) What is the temperature of the flue sheet, free from scale? A.—This has not been accurately determined. The flue sheet is one of the vehicles by which the heat of the fire is transferred to the water, and, as a matter of fact, it may be cooler on the water side than it is on the fire side. Steam at 200 pounds pressure, as shown on the gauge, is at a temperature of about 386° Fahr., and it is probable that the flue sheet only becomes very slightly hotter than the water and steam next to it, if at all. If it

became much hotter the flue sheet would burn away. Its function is to transfer heat, not to retain it, and it derives its heat from the gases in the firebox, which are, of course, at quite a high temperature.

(4) Is there any difference in the temperature of the top and bottom of the flue sheet? A.—There may be slight differences at times, due to local conditions, but, as the steam and water in the boiler are practically at the same temperature, the flue sheet on the average is about the same.

(5) What causes the bottom flues to leak more than the top ones? A.—The leaking of flues is caused by the sudden changes of temperature of the flues and the flue sheet, and although, as we have said, the average temperature is about the same, yet the opening of the firebox door or other local causes which allow a rush of cold air into the firebox at any time may produce a sudden contraction of the flues; which makes minute gaps in the joint between flue and sheet and show as a leak. It is the unequal contraction which takes place which causes a leak, consequently it may be that one part of the flue sheet may be hotter or colder than another part at any particular moment, or the flue ends may become temporarily cooler. The sudden local change in temperature may not be exceedingly great, but is enough to produce a leak. (6) Why do tubes leak at the firebox end oftener than at the smokebox end? A.—In the firebox the local changes of temperature are more rapid and more marked than in the smokebox, hence the greater sensitiveness of the firebox ends.

### FLUTTERING IN K TRIPLES.

(35) J. C. C., East Salamanca, N. Y., writes: 'On the cars equipped with K triples I notice a fluttering or buzzing noise, which sounds like a leaky emergency valve, but there is no leak at the exhaust port. Why is it? A.—When the K triples are charging the reservoirs, brake-pipe air flows past the non-return check valve and causes this check to raise and lower rapidly, thus producing a buzzing or fluttering similar to that had with the older triple when its emergency valve leaks. This fluttering should cause no uneasiness, unless it is accompanied by a blow from the exhaust port of the triple, when it should be cut out, if in a train, and carded for inspection and repairs.

### LUBRICATOR ACTION.

(36) A. J. D., Whiting, Ind., writes:

With a Nathan No. 8 lubricator feeding, and engine standing, steam flows through lubricator and out of steam chest vacuum valve. With lubricator steam valve shut off, engine standing, no steam shows at steam chest vacuum valve. What is the matter with lubricator? A.—In locomotive lubricators the delivery end of the cup is in constant communication with the boiler steam supply through the equal-

izing pipes in the condenser, and as long as the operating steam valve of the lubricator is open steam can blow in small quantity through the choke or reducing plug, whether this be located at the outlet of the cup, as in the Nathan lubricator, or at the steam chest. This is necessary in order to have the lubricator properly equalized between the boiler pressure and that of the steam chest. This prevents the syphoning out of the oil reservoir or body, whenever steam is shut off from the steam chest end of the system.

### EFFECT OF SAND IN BRAKING.

(37) W. D. O., Galeton, Pa., writes: When making a heavy application of the brakes, will sand help much to make a shorter stop? A.—It will depend on the condition of the rail. If the rail is clean and dry at the time brakes are applied the stop will not be materially shortened by the use of sand. If it is wet and slippery, sand applied in time to get under all the wheels when the brakes are applied will help very much to make the stop shorter than it would be if sand were not used at all. Sand applied to slippery rails after brakes are on hard will help to shorten the stops, but it will also cut flat spots very rapidly in wheels that are sliding at the time it is dropped. Unless it is an emergency stop, then, sand should not be used after the brakes are applied, for if it is, flat wheels are likely to be had.

### STRAIGHT AIR AND K TRIPLE.

(38) J. McK., Little Falls, N. Y., writes: When releasing brakes on long trains, it is good practice to apply the straight air before putting the automatic brake valve in release to avoid breaking the train in two; but if the straight air brake will do this, what is the use of the K triples holding back on the release of the front brakes? A.—The holding power of the straight air brake on the engine and the tender is limited by the cylinder pressure and the leverage, the same as the tractive effort of the locomotive is limited by the size of the steam cylinders, the stroke of the pistons, the diameter of the drives, the steam pressure, and so forth. Now, as the tractive effort limits the number of cars that the locomotive can haul, so does the amount of retarding power of the straight air brake limit the number of cars in a train of which it can hold the slack bunched sufficiently well to prevent damage to draft gear, and to prevent break-in-twos when releasing at slow speeds. Hence it has been found by experience that trains of forty-five or more cars require a greater retarding power on the head end when releasing at slow speeds, to prevent shock and damage to draft gear and to prevent break-in-twos, than the straight air brake can always furnish; and to sup-

ply this needed additional power, as well as to bring about a smoother and more uniform release throughout the whole train, the uniform recharge and retarded release features were incorporated in the K triple, in addition to its quick service application feature.

#### STUDY OF PARTS AND OPERATIONS.

(39) W. F. E., Philadelphia, Pa., asks:

(1) What is an eccentric? (2) What are the positions of the eccentrics on the axle in relation to the crank pin? (3) By what means are the eccentrics made to operate the valves? (4) How is the travel of the valve changed by the motion of the link? (5) Is there any limit to economical cutting back of the reverse lever? A.—These questions cannot be fully answered in the short space at our disposal in the question columns of this paper. In order to get a proper knowledge of the points you refer to, we would advise you to study up locomotive valve motion, and for that purpose we would suggest that you get Forney's Catechism of the Locomotive, or Sinclair's Engine Running and Management, or some such work, which will give you a comprehensive knowledge of the whole matter. Simply answering these questions would not put you in possession of the information you really need, because more is involved than appears in these few isolated queries.

#### LARGE RAILROAD SHOPS.

(40) W. A., Sherburn, Minn., asks:

Which is the largest railroad shops in the United States? I am not particular as to number of men employed, or work turned out, but size of buildings. I would also like to know what others—about six of them—in the order of their importance. A.—This is a statistical question, and we cannot answer it very definitely. As to size of buildings, however, without placing any importance on the order in which



JUST SIMPLY GRAND.

we name them, we may say that the Collingwood (Ohio) shops of the Lake Shore and Michigan Southern is a large modern establishment; so is the Missouri Pacific shops at Sedalia, Mo.; the Philadelphia and Reading shops at Reading, Pa.; the Delaware, Lackawanna and Western shops at Scranton, Pa.; the Lehigh Valley Railroad shops at Sayre, Pa., and the Canadian Pacific shops at Montreal, Canada.

#### Honeymooning on the Lehigh.

It is not often that you see a railroad man behind the footlights, but in one sense you can see Mr. B. F. Hardesty, of the Lehigh Valley, in that position, for he has been "on the stage" at several of the Keith and Proctor theatres in New York, and the way it happened was this: Mr. Hardesty aided and abetted a very pretty little comedy which was got up by the kinetograph



NICKEL PLATED TIP ON THE LEHIGH.

department of the Edison Manufacturing Company for the purpose of taking a moving picture for the theatres. The picture is called "The Honeymoon at Niagara Falls," and is a film 1,000 feet in length and contains 16,000 separate photographs, and it takes from ten to fifteen minutes to see them all. It is a well conceived and a well executed piece of work, and shows the trouble often taken, simply to entertain.

The scene is on the Lehigh Valley Railroad, and as the Black Diamond Express draws into the station a party of friends are gathered at a railroad station awaiting the arrival of a young couple who have just been married. The carriage containing the bride and groom approaches the station and all rush down the platform to meet it. The party of alleged friends pelt the unhappy couple with rice, paper confetti, old shoes, etc., and away they all go for the Falls.

When the train arrives at Niagara the bride and groom alight; the lady drops an illustrated magazine, which is ceremoniously picked up by the groom, who then turns to the porter to hand that worthy a tip. It so happened (and we were told this on the Q. T.) that the gentleman acting as the groom found at the critical moment that he had only very small change in his pocket—in fact, a single nickel. The moving-picture machine was taking it all in, so there was no time for explanations and the party had to keep moving; so the groom abjectly gave the nickel to the porter, caught the bride's arm and they hurried off. The porter paused, speechless, glanced at the coin, and looked after the couple. And here let it be noted that there was no sham and no make-believe to suit the necessities of a picture. The look of utter sadness

and disgust on the porter's face was the faithful portrayal of his innermost feelings. Every one felt so sorry for him, and even the kinetograph, which is the heartless machine that takes the pictures, was almost put out of countenance. The net result is that the spectators have a good laugh and the porter is in—well, just five cents.

The newly wedded pair first stop at Goat Island, from which point they get a magnificent view of the American Falls. Later a trip on the steamboat "Maid of the Mist" appeals to them, and they are seen going aboard. Reaching the deck, they don rubber coats and hoods. The start is soon made, skirting the base of the Falls, where the spray, thrown high in the air, drenches everybody and everything, the happy couple included. A panoramic view of the Horse Shoe Falls is seen from the Canadian side, and at the base of the Falls appears the "Maid of the Mist," loaded with eager tourists, and of course, the happy couple. A view of the American Falls from the Canadian side is shown, which is just simply grand. It includes the bride and groom strolling along the rocky shore and occasionally sitting down to view the rushing torrent. The Cave of the Winds is, of course, entered, the pair being dressed in the regulation rubber suits. A beautiful panoramic view of the whirlpool rapids is also given. Then the return to the railway station, the Lehigh Valley's famous Black Diamond Express train comes in, and the party are off for New York.

All through this picture the train scenes are good, and the effect of the tumbling water—blue as seen in mass, and foamy white as it pours over stones and rocks—is marvelously reproduced. Great credit must be given to Mr. E. S.



MAID OF THE MIST NEARING FALLS.

Porter, of the Kinetograph Company, who "engineered" the various scenes and took the pictures, and if you want to get a good idea of what "honeymooning" at the Falls is like, drop in at one of the Keith-Proctor theatres when this picture is running and you will, like many others, be touched by the porter and moved by the motion pictures.

# Air Brake Department

CONDUCTED BY J. P. KELLY

## Defects of New Brake Equipment.

Editor:

The advent of the new Westinghouse engine and tender brake equipment has been a remarkable success in many respects; yet it appears that the advantages of this equipment are not yet fully realized by all railroad men connected with its operation.

It is not only a more efficient brake, with less apparatus, but it requires less attention, and it is, consequently, less expensive. Nearly all new locomotives are being equipped with this brake, and it has given excellent service, with very little trouble. However, the valves comprising this apparatus are comparatively new and very few defects have developed; but as they continue in service and become worn more defects will follow.

Nothing has appeared in these columns concerning the S. F. 4 pump governor beyond a description of its construction and operation, and this governor, owing to its construction and method of piping, is affected in its operation by other valves in the equipment, which is not the case with the F. 7 governor used with the standard brake of two years ago.

The standard one-inch pump governor is operated entirely by main reservoir pressure, and the governor pipe breaking would cause it to lose control of the pump and make a bad leak.

With the new S. F. 4 governor, should the pipe connected at F. U. P. break, the governor would stop the pump and keep the steam valve closed until the pressure in the main reservoir fell below 40 pounds. It would then be necessary to plug this pipe, and to blank the one connected at A. B. V. which would allow the high pressure top to control the pump.

The low pressure top, which is usually adjusted to maintain 130 pounds in the main reservoir, should operate when the handle of the H. 5 brake valve is in release, running, and holding positions, as it has brake pipe and spring pressure on top of its diaphragm and main reservoir pressure beneath. It follows then that the correct operation of this top depends to a certain extent upon the condition of the B. 4 feed valve and the H. 5 brake valve.

It sometimes happens that the low pressure governor stops the pump at 130 while the brake valve handle is in running and holding positions, but in train brake release position the main reservoir hand goes to 140. This is usually due to a small leak in the slide valve or regulating

valve of the B. 4 feed valve. The leak is not sufficient to increase the pressure in the long brake pipe on the engine above that for which the valve is adjusted, but in release position the feed valve is required to maintain the pressure in the short feed valve pipe only and the small leak quickly increases the pressure above that for which the feed valve is adjusted. The low pressure governor is then rendered inoperative, and the high pressure top will control the pump.

This same leak into the feed valve pipe may come from the rotary valve seat of the H. 5 brake valve, or it may come through the diaphragm of the governor top, but it will affect the governor only on a light engine or very short train while the brake pipe is overcharged. The leak on the H. 5 rotary valve seat or past

on the engine, if the brake valve does not leak, by closing the main reservoir cut out cock, which will bleed off all air pressure, then take valve apart and clean it, replacing all parts except the spring body and the diaphragms.

By placing the H. 5 brake valve handle on lap position and opening the main reservoir cock air will be admitted to the top of brake valve rotary and through the feed valve as far as the regulating valve which will move the supply valve piston and open port c which should result in a heavy blow at this port which should cease as the pressures equalize around the supply valve piston. The movable parts can then be operated by unseating the regulating valve with the finger which should be followed by a short heavy blow at port c. The length



SIGHTSEERS ABOUT A PASSENGER TRAIN WRECK.

the diaphragm in governor will increase brake pipe pressure, while handle is on lap position, and it will force the equalizing piston and the slide valve of the distributing valve to release position, but it will not release the brake, as the exhaust port of the application chamber is blanked by the double cut out cock. If the B. 4 feed valve does not constantly maintain a predetermined pressure in the brake pipe and above the diaphragm of the governor the work of the governor is likely to be erratic. The feed valve may maintain this pressure with the light engine and fail when coupled to a train. If the brake pipe pressure falls while the main reservoir pressure is at its maximum, the governor will stop the pump and necessitate placing the brake valve handle in release position to again start the pump and charge the brake pipe.

The feed valve should be cleaned and tested regularly. A fair test can be made

of this blow indicates the amount of leakage past the supply valve piston packing ring, a very short blow indicating a leaky ring. Then test cap nuts, regulating valve, and port c for leaks; if none exist replace diaphragms and spring box, place the brake valve handle in running or holding positions, and set the feed valve by gauge. If a leak is found at port c the slide valve is leaking that amount.

A more exacting test is required after repairs have been made to the feed valve.

A small port drilled through the piston is relied upon to equalize the pressure surrounding the piston, but this port often stops up and the brake pipe is overcharged. If the packing ring is left open at the ends about 1-100th of an inch the feed valve will work accurately regardless of the stopped up port.

The B. 3 reducing valve can be cleaned and tested in the same manner. After closing the reservoir cock, the stop cock

on signal line should be opened to prevent the possibility of back leakage through check valve. When cleaned and ready to test open main reservoir cock, and when ready to set place handle of independent brake valve in service position and set by single pointer air gauge.

Washington, D. C. G. W. KIEHM.

**Handy Device.**

Very handy and efficient device for removing air pistons from the rods is shown in the illustration "Piston Remover." This tool was gotten up by Mr. T. J. Cutler, foreman of air brake repairs on the Northern Pacific. It was later improved by Mr. F. G. Kellogg, air brake foreman of the same road at South Tacoma, Wash. They have used it with success in air pump repair work. It is now made and furnished by the Westing-

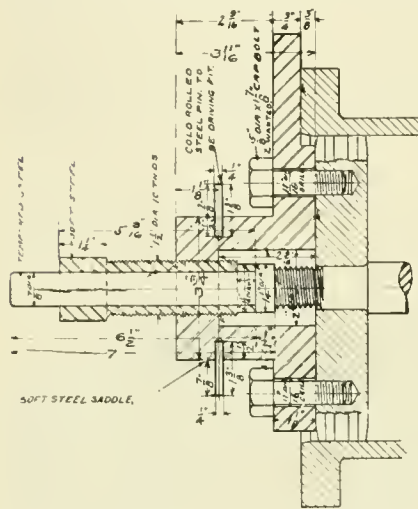

SECTION A-B  
PISTON REMOVER FOR AIR BRAKE PUMP.

house Air-Brake Company. It is practically a screwjack, which may be bolted to the air pistons of the 8, 9 1/2 and 11 inch pumps in such manner that a steady and powerful pressure may be applied to the piston rod to force it and the air-piston head apart. The method of attaching the device to the piston head, as well as the scheme on which it operates, will be easily understood from the illustration.

**Keep Up the Locomotive Brake.**

It pays in more ways than one to keep a good brake on the locomotive. Where the engine brake is made to take care of the engine properly—that is, hold the engine without assistance from the cars in all brake applications—there will be less wheel sliding under the train.

In emergency applications there will always be a shorter stop, with less tendency for the engine to break away from the train.

**Braking Power on Grades.**

Those who control the motion of freight trains with the air brakes on heavy descending grades know that there is not a large margin of retarding force on which to depend, and hence they are careful not to let the speed get higher than experience indicates is safe.

To such the following will probably be of interest: A car weighing 40,000 pounds, having a braking force of 85 per cent. of its light weight, will exert a retarding force at slow speeds of about 6,900 pounds.

It is important, then, before descending grades, to check up carefully the number of tons to be handled against the number of good brakes to handle them with.

On a two per cent. grade gravity will exert a pull on this car of about 800 pounds. This leaves a balance of power

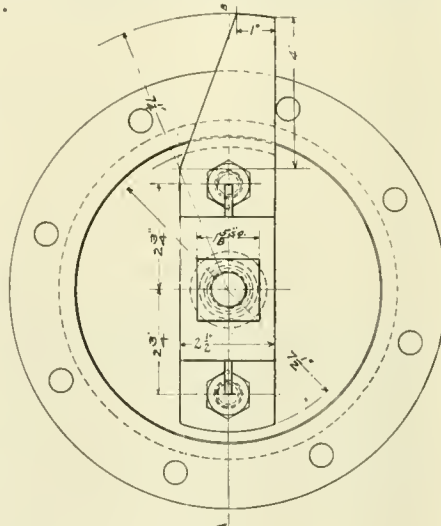

A freight engine with twenty-six loads left the terminal on the Louisville division of the Pennsylvania Lines to make her run of 110 miles. The weather was cold, and the triple valves kept freezing up. The engineer drained the main reservoir several times, getting considerable water at each draining; but the triples continued to freeze, and so it was decided to shut off the pump, and to complete the trip without the air.

Upon reaching the end of the run the engineer reported the pump pumping steam into the brake pipe. It was his first run, and all the old machinists gave him the laugh; nevertheless, he stood by his report, even though he did not understand the trouble, and, of course, could not explain it.

The shop foreman finally ordered the pump to be taken off the engine and examined, and when this was done a hole was found in the piston rod extending from the reversing valve-rod hole to the bottom end of the rod in the air end of the pump. When this defect was found, the reason of steam and water in the brake pipe was apparent.

JOHN R. POGUE.

No. Madison, Ind.

[While this defect may be the first one of the kind our correspondent has ever had to deal with, water has been found in large quantities in brake pipes before this, due to similar defects in the pump piston-rod.—Ed.]

**Air Brake Convention.**

The 14th annual Air Brake Association Convention will be held in Columbus, O., at 9 A. M., Tuesday, May 14, 1907.

The Committee on Arrangement and Entertainment are: Mr. S. D. Hutchins, Chairman, 1132 Columbus Savings & Trust Bldg., Columbus, Ohio; Mr. William Holbrook, Mr. T. M. McGurty, Mr. J. E. Ganson, Mr. C. M. Kidd, members.

The committee has selected as convention headquarters the Great Southern Hotel, located on the corner of High and Main Streets, where rates have been secured as follows: European plan, \$1.00 to \$1.50 per day, without bath, one person to a room. European plan, \$2.00 to \$2.50 per day, with bath, one person to a room. For each additional person a charge of \$1.00 will be made. American plan, \$2.50 to \$3.00 per day, one person to a room, without bath. American plan, \$3.00 to \$3.50 per day, one person to a room, without bath. American plan, \$3.00 to \$3.50 per day, one person to a room, with bath. American plan, two persons to a room, with or without bath, double the rate, less 50 cents.

**Peculiar Air Pump Trouble.**

Editor:

I have never before heard of the air pump failing from the following cause, and so I am writing you about it.

To keep your secret is wisdom; but to expect others to keep it is folly.—Holmes.

# Electrical Department

## What is a Watt?

By GEORGE SHERWOOD HODGINS.

The word "Watt" is an electrical term, and stands for a certain unit of power. Work, as distinguished from power, is defined as pressure acting through distance and is usually expressed in foot-pounds, as the foot is a convenient unit of distance, and a pound is a common standard of weight or pressure. When the word power is used it signifies a rate at which work is done, as work being carried on so that a certain quantity of it is performed in a stated time.

James Watt, the Scottish inventor and engineer, was the man to whom we owe the idea of a horse-power, and when the electric unit involving the idea of work came to be formulated, the name of Watt was chosen to indicate this unit, just as that of Volta has given us the term volt, and Faraday, the farad.

Watt considered that taking the average, a London dray horse was capable of doing the work of lifting 33,000 lbs. through one foot of distance in one minute of time, against gravity. The introduction of this time limit, the minute, gave the unit of power or the rate of performing work. This or its equivalent has ever since been called a horse-power. It is not probable that a horse would be able to perform work continuously at this rate for any considerable period of time, but for ordinary purposes the horse-power is a convenient unit. It is, in fact, work performed at the horse's rate of doing work which we refer to when we speak of a horse-power and that is equivalent to 33,000 foot-pounds per minute, or to the raising of 550 pounds one foot high in one second, and if repeated continuously for one hour it is spoken of as a horse-power-hour.

The electrical unit called the watt is capable of being represented in terms of the horse-power, and in that form it is perhaps more intelligible to those who are familiar with mechanical, rather than with electrical expressions. The electrical watt is the product of volts multiplied by amperes, where the volt is the unit of electrical pressure and the ampere is the unit measuring the intensity of an electric current. The ampere is represented as the unvarying electric current which when passing through a solution of nitrate of silver

in water deposits silver at the rate of 0.001117 of a gramme per second, or a current which in each second deposits by electroplating 0.00033 grammes of metallic copper, is said to be of one ampere intensity.

The ampere, therefore, includes the conception of rate of doing something, and as the watt is the mathematical product of volts by amperes, it necessarily includes the idea of rate, though not that of absolute quantity. The chemical separation involved in the deposition of pure metal from a solution in a given time becomes a measure of intensity of activity, but is not regarded as the performance of work, in the sense of pressure acting through distance.

The expression "watt per second," though correct, is not used for the same reason that the expression "horse-

power per minute" is not used. The conception of horse-power involves the idea of rate, and so also does the watt, but watt-second is what is really meant by the general use of the term watt.

rest for the man who has his office or house lighted by electric lamps, because the kilowatt-hour is the unit upon which the power and light companies base their charges. The kilowatt-hour is stated on the accounts rendered, to be approximately equivalent to the steady use, for one hour, of 20 standard incandescent lamps, each one giving about as much light as 16 standard sperm candles. The kilowatt-hour is also roughly speaking, equal to the use, for one hour, of two arc lamps such as are employed in street lighting.

The mechanical energy necessarily expended for the production of light in 20 incandescent lamps for one hour, is about equal to 1.34 horse-power and the energy required to keep up the glow in one of these lamps for an hour must therefore be the twentieth part of the number just given or 0.067 of one horse-

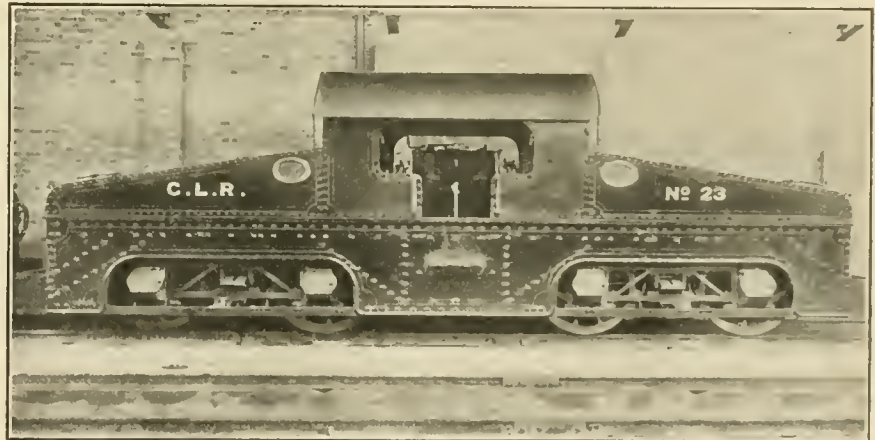

ELECTRIC LOCOMOTIVE ON THE CENTRAL LONDON RAILWAY.

power per minute" is not used. The conception of horse-power involves the idea of rate, and so also does the watt, but watt-second is what is really meant by the general use of the term watt.

Careful experiments have demonstrated that 746 watts per second are equal to 550 foot-pounds per second, or to state the equation in its usual form, 746 watts equal one horse-power. The form in which electrical power is generally sold is computed on the basis of kilowatt-hours. The prefix kilo comes from the Greek *chilioi*, one thousand. A kilowatt, written also k.w. is therefore 1,000 watts. The kilowatt-hour is the performance of work at such a rate that 1,000 watts per second shall be delivered continuously for one hour.

The kilowatt-hour has a special in-

power. The expenditure of this amount of energy may be more readily comprehended if stated in terms of what we may here call man-power instead of that of the horse.

In former days the power required to drive church tower clocks was obtained by the gradual falling of a heavy weight, attached to a rope which was wound round a drum. This arrangement was similar to the mechanism of a grandfather's clock. When the church clock had run down, a man wound it up by attaching a crank-handle to the axle of the drum, and revolving it until the weight was drawn up to the required height inside the tower. If the same style of mechanism could be applied to the production of light in an incandescent electric lamp, a weight of one pound would have to

be raised 36.85 feet in each second in order to maintain the glow, for one hour in one of the 16-candle power bulbs with which we are all familiar.

In every machine there is a certain amount of loss due to internal friction, so that we never get out of a machine, as work, the full amount of energy put into it. This is true of all the transformations of energy used in the arts. In a recent lecture delivered by Sir James Dewar before the Royal Institute in London, he stated that out of the total amount of energy required for one glow lamp, only 3 per cent was actually transformed into light and that 97 per cent was expended in a non-luminous form. This statement is not so surprising to those who have reason to know that in the best stationary steam engine practice, it is probable that not more than 15 per

cent produced by the downward movement of the one pound weight for a distance of only 1-10 feet in each second. No light, however, would appear unless the whole distance of 36.85 ft. had been traversed by the weight. In this, however, the incandescent lamp is superior to the 16 candles which it supplants, for in their case the luminous energy produced by the burning of each one is only 2 per cent, while the non-luminous energy is 98 per cent of the total amount liberated by the consumption of the melted fuel, by the tiny flame.

#### Steel Suburban Motor Car.

In addition to the regular electric locomotives used on what the New York Central call the electric zone, that company has in its rolling equipment one hundred and twenty-five

13.7 tons, while the trailer truck is 5½ tons. The motor equipment consists of two motors of 200 H.P. capacity each, mounted on the motor truck. The cars are equipped with Sprague General Electric multiple control apparatus; Westinghouse air brakes; National Malleable Castings Co.'s radial draft gear. The cars are fitted with both electric and steam heat, electric light and Pintsch gas light. The car measures 48 feet 11½ inches long inside the body. The height from rail to top of roof is 13 feet 9½ inches. The width over side sills is 9 feet 8¼ inches. The under-frame consists of two 8 inch, 18 lb. to the foot, I-beams placed at 24 inch centres. They extend from buffer beam to buffer beam, and are the centre sills and take the buffing and pulling strains.

The motorman's controller is similar to that used in the New York Subway and is made with what is called on the road the dead-man's handle. The arrangement with this gruesome name is simply a button, like the projecting handle of a locomotive check valve, only smaller. This little handle is depressed by the motorman in grasping the main handle and has a vertical motion of about ¾ of an inch. The little button when pressed down can rise about ¾ of an inch without producing any effect, but in case a motorman overcome by heat or for other reasons relaxed his hold on the controller handle, the button would fly up to the full extent, the electric current would be at once cut off, and brakes would be applied in the emergency. It is only necessary to let go of the controller handle in order to insure prompt automatic action of brake and the entire cessation of the electric impulse which drives the car.

#### Illinois Traction Locomotive.

The accompanying illustrations show one of two locomotives recently built by the General Electric Company and American Locomotive Company for the Illinois Traction Syndicate. The locomotive is a swivel truck switching type weighing 40 tons on drivers, and Fig. 1 shows the general appearance of the machine. The cab is the well-known switching locomotive cab of the general type developed some years ago by the General Electric Company, having a main operating cab with sloping ends, the two spaces, one at each end, are covered with sloping tops. The operating cab, having a floor space of 9 ft. by 9 ft. 6 ins., stands in the center of the locomotive and contains an air compressor, together with engineer's seat at the window, control mechanism, master controllers, brake valves and sander apparatus.



MOTOR COACH FOR SUBURBAN TRAFFIC, NEW YORK CENTRAL.

cent of the total energy developed in the burning of the fuel, is ever transformed into useful work while in the case of a locomotive probably from 6 to 10 per cent is all that is available. In a general analysis of electric light radiations, many years ago, Tyndall found that the invisible emission from this source of light was eight times that of the visible.

Taking Prof. Dewar's figures and applying them to the case before us, it is evident that out of the total energy stored up when the hypothetical one pound weight was raised in the clock tower—for the production of light, and steadily liberated during one hour by the gradual fall of one pound through a distance of 36.85 feet in every second, that a distance as great as 35¾ feet per second would be traversed by the descending weight in the production of heat and in overcoming internal resistances. Further, that all the actual energy which the lamp was able to radiate as light, could be

steel motor passenger cars of the type shown in our illustration. The car will hold sixty-two persons. It is vestibuled and when the doors are closed the car can be operated from either end.

The cars are spoken of as all steel cars for the reason that wood is used only for holding part of the interior finish in place, and is not used in the under frame or in the structural part of the car. The wood so used is encased in metal, and material otherwise inflammable has been subjected to a fire-proofing process. All these cars are equipped with a motor on one truck. The company is, however, buying fifty-five similar cars without electric equipment, and these will be used as trailers.

The length of the motor car over bumpers is 60 feet. The truck centres are 38 feet 6 inches apart. The total weight of the motor car fully equipped is 53 tons. The body itself weighs 33.8 tons. The motor truck weighs



The end spaces have an area of 9 ft. 6 ins. by 5 ft. 6 ins. each, with a 24-inch platform or passage, one on either side, running from the operating cab to the end of the locomotive. The doors

cast with the steel tires fused onto them in the making. The journals are 5½ ins. x 10 ins., the construction being particularly heavy in order to meet the demands of locomotive service. The plate bolster

effort with a load on the motors slightly in excess of their rated load.

Fig. 2 is a view of the interior of the locomotive cab showing the apparatus at one of the engineer's operating positions, and a view of the interior of the space covered with the sloping roof. In front of the engineer's seat is a master controller operating the contactors used for single unit control. Brake apparatus for both automatic and straight air and pneumatic sanding valves are also within easy reach. In this end space are also contained the contactors and rheostats of the control system. The air reservoir and pneumatic sanders are used to operate through nozzles carried upon the trucks directly in front of the forward wheels of the locomotive. In the center of the operating cab there stands an air compressor worked from the 500 volt circuit, having a piston displacement of 50 cubic feet per minute.

Some of the principle dimensions of the locomotive are: Length over all, 31 ft. 1 in.; height over cab, 11 ft. 9 ins.; width over all, 9 ft. 6 ins.; rigid wheel base, 6 ft. 6 ins.; weight of electrical equipment, 27,500 lbs.; weight without electrical equipment, 52,500 lbs.

That there is an abundance of lions in Central Africa is proved by these telegrams, said to have been sent recently by

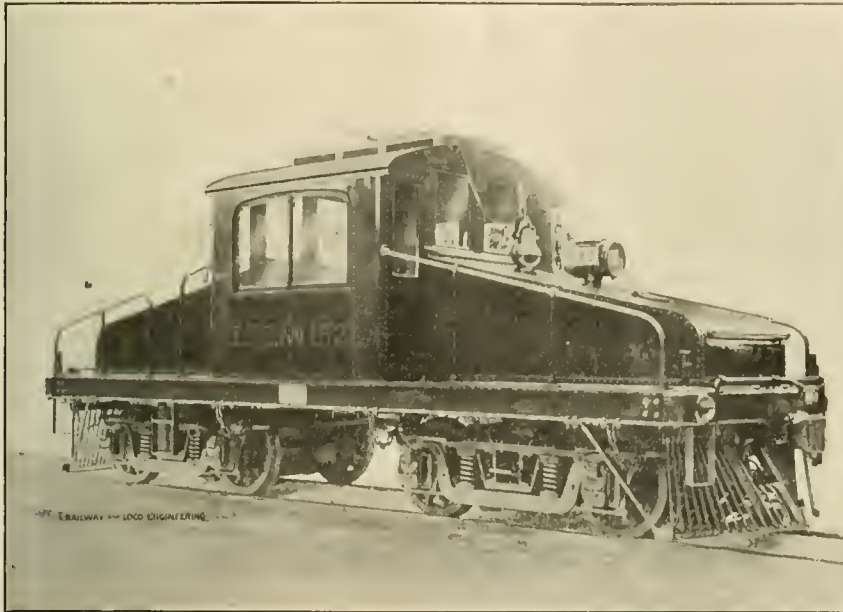

ILLINOIS TRACTION SYNDICATE ELECTRIC LOCOMOTIVE.

from the cab open at diagonally opposite corners on these side platforms or passages, thereby giving easy access from the cab to the end of the locomotive; while on the operating side it gives the engineer an unobstructed view of the track in front of him, or of the train which he may be handling, or of the brakeman or switchman at the couplers.

The cab framing is built of 2 x 2 in and 3 x 3 in angles, with sides and roof of ½-in. sheet steel.

The platform is built up of a framing consisting of four 10-in. channels running the length of the locomotive and riveted to the end frames and bolster. The end frames are iron castings with push pole sockets near the outer ends, and with lugs for riveting to center and side sills and the draw bar castings. Over the center pins the sills are trussed together with heavy braces stiffened by castings and forming a built-up body bolster. The floor consists of solid sheets of ¾-in. plate riveted to the longitudinal sills and serving as a stiffening member for the frame. The M.C.B. vertical plane coupler is carried in a draw bar casting bolted to the end frame and center sills.

On each end of the locomotive there is carried a heavy pilot built of 1-in. round bars riveted to a ½-in. bottom plate below and the 4 x 4 in. angle above. The truck is of M.C.B., equalizer type with plate bolster. The wheel base is 6 ft. 6 ins., the wheels are 36 ins. in diameter, with fused steel tires. This means that the wheel centres are

carrying the center pin and side bearings is built up of 9-in. channels and plates riveted together. The whole truck construction is heavy, and is designed for the service in which it will be used.

The motor equipment consists of a

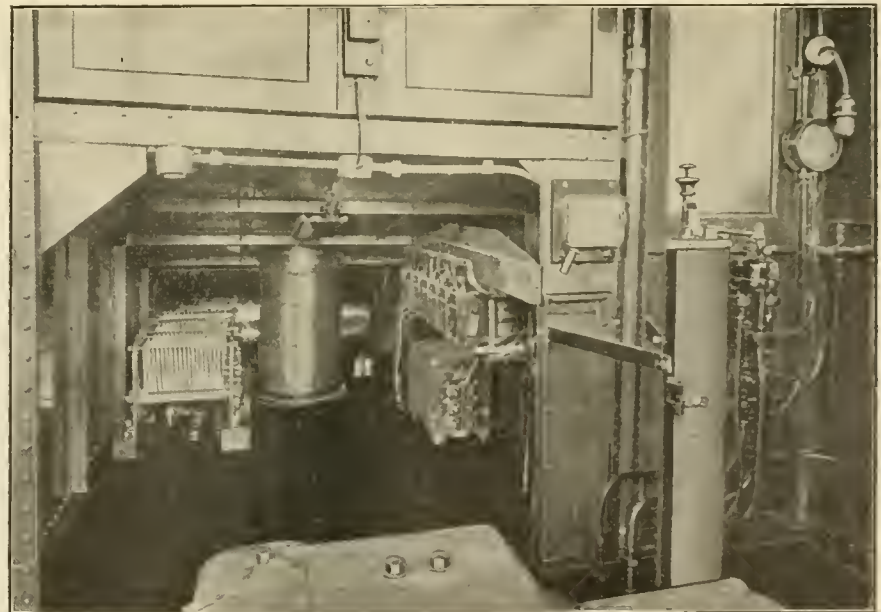

INTERIOR SHOWING CONTROLLER WITH BUTTON ON TOP OF HANDLE.

type of motor designed especially for the slow speeds and heavy tractive effort required in freight service. At the rated load of the motors the locomotive will give a tractive effort of 16,800 lbs., and at the slipping point of the wheels will develop 20,000 lbs. tractive

a railway station master to his division headquarters: "Please send further police protection. Men very brave, but less so when roaring begins." And "Please let 10 a. m. run up to the platform disregarding signals. Signalman up post, lion at bottom."

### Under Water Coal Storage.

About the year 1902, the Western Electric Company of Chicago, Ill., after carefully investigating the ques-

three sections into four equal parts. There are also two railroad tracks, one on each side outside the pit, running the entire length, so that coal cars

use as it is believed that the handling of the coal will result in its being dry enough for all practical purposes by the time it reaches the boilers.

One of the leading English engineering papers, commenting on a report that Lord Charles Beresford had said that possibly half the heating value of coal is lost when the coal is stored for a considerable length of time in piles exposed to the open air, made the statement that the loss in calorific value, will probably be found in practice to be between 10 and 15 per cent. with a possible maximum of 20 per cent. In the same paper, Lieutenant Carlyon Bellairs, R.N., in a communication to the editor, states that from second-hand evidence he believes that the coal stored at Hong Kong loses from 20 to 40 per cent. of its calorific value with a probable average of from 20 to 25 per cent. The British Admiralty have made some successful experiments in the storage of coal under water at Portsmouth, England.

Mr. John Macaulay, General Manager of the Alexandre Docks & Railway of Newport, Wales, contributed an article to *The Engineer* (London) some time ago, in which he stated that as a result of his experiments and observations he believed that coal submerged to a considerable depth in water so that it would be under pressure, would not lose more than 3 per cent. of its calorific value after being stored for twelve months, whereas if

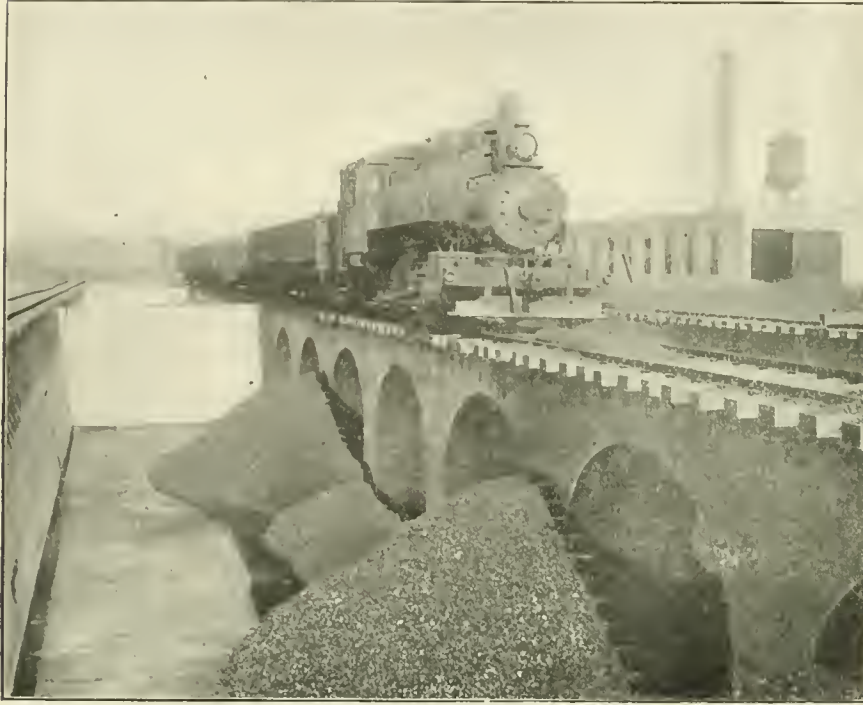

COAL STORAGE BIN, JUST BEGINNING TO FILL WITH COAL.

tion of the uncertainty of the coal supply, due to strikes and other conditions beyond their control, decided to provide for storage of a considerable amount of this fuel. Their experience with coal bunkers at one of their plants showed very clearly that the Illinois coal, which this Company makes use of, when stored in ordinary bins, exposed to the air, suffered the risk of spontaneous combustion, and in any case, deterioration in quality. It was decided to dig a hole in the ground and store a large quantity of coal under water. This was carried out with very satisfactory results inasmuch as since then no trouble has ever been experienced with spontaneous combustion.

When the company decided to provide for large storage of coal at the new plant at Hawthorne, Ill., the same plan was followed and a storage pit, built of concrete, divided up into three sections and covering a ground area of about 310x114 feet, was arranged for. It was made so that it could be filled with water so as to entirely cover all the coal that may be placed in it. As constructed, each section is approximately 15 feet in depth and the whole pit has a capacity of approximately 10,000 tons, and this is kept for emergencies. Three railroad tracks are carried on concrete piers and arches running the entire length of the pit, thus dividing each of the

may be emptied into or loaded from the storage pits while on any one of five railroad tracks.

A locomotive crane, fitted with a

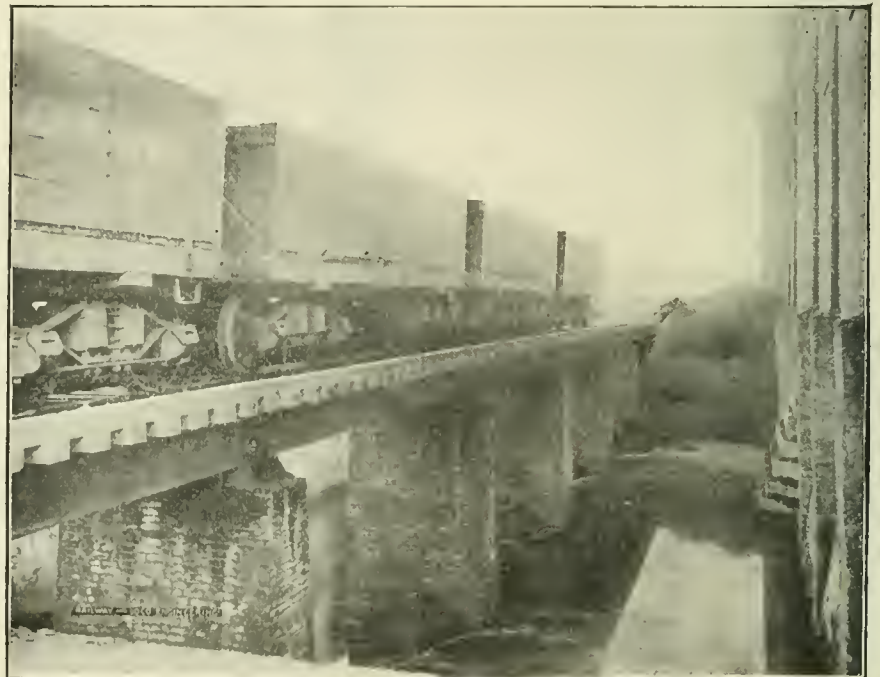

COAL STORAGE UNDER WATER. THE EMPTY BIN.

grab bucket, is provided for taking the coal out of the storage pit and loading it into coal cars. No provision is made for drying the coal before

the same coal was stored in the open air in England, at least 12 per cent. would be lost, and in a hotter climate 18 to 24 per cent. would disappear.

These opinions apparently all refer to bituminous coals with probably 30 to 35 per cent. of volatile combustible matter similar to or equaling the Illinois coal which the Western Electric Company makes use of. Mr. Macaulay, in the course of his experiments, found that coal submerged in salt water showed

Some of the typical ratios of the design are as follows: Ratio of weight on drivers to total weight, 85 per cent.; ratio of heating surface to grate area, 56 per cent.; ratio of tractive effort to heating surface, 11.4; ratio of heating surface to volume of one cylinder, 524; ratio of grate area to volume of one

for bracing between the main frames. The introduction of the heavy cast steel cross-tie between the front and main pedestals in these engines greatly strengthens and stiffens the frames. The Mogul type of locomotive has been the favorite type of freight engine on the Vandalia Line, and these engines



COAL STORAGE UNDER WATER. APPEARANCE OF THE BIN BEFORE BEING FLOODED.

an apparent increase in heating value, which may or may not have been caused by the salt in the water. The Western Electric Company uses fresh water and has secured very satisfactory results from the under water storage of bituminous coal.

**Heavy Vandalia Moguls.**

The Vandalia Line have recently added to their motive power equipment three very heavy 2-6-0 locomotives. They were built at the Schenectady works of the American Locomotive

cylinder, 0.3; ratio of tractive effort to adhesive weight, 4.77. Compared with other designs of Mogul locomotives, these engines have a considerably greater heating surface in proportion to the cylinder volume, which gives them a boiler capacity well adapted for all-round freight service.

These engines are equipped with the Walschaerts valve gear, and considering the fact that the Mogul type offers no difficulties to a simple design of Stephenson link motion, without transmission bars or other objectionable fea-

represent the highest development of weight and power in this type.

The main drivers are the centre pair and their tires are without flanges. The driving wheel diameter is 63 ins. The driving wheel base is 14 ft. 9 ins. and the total engine wheel base is 23 ft. 10 ins. The piston valves have 5 ins. travel with a steam lap of 1 1/4 ins. They are set with 3/16 in. lead, which is, of course, constant with this style of valve gear. The exhaust clearance is 1/8 in.

The boiler is a straight top one, with a diameter of 76 5/8 ins. at the front end.

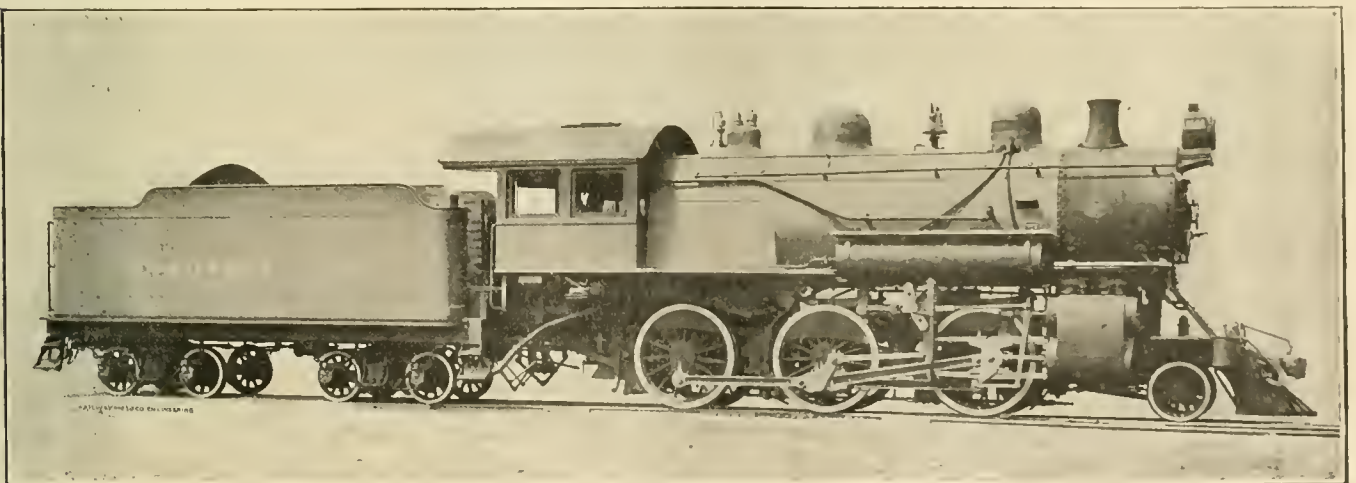

HEAVY MOGUL ENGINE FOR THE VANDALIA LINE.

W. C. Arp, Supt. of Motive Power.

American Loco. Co., Builders.

Company and weigh, in working order, 187,000 lbs. The weight on the driving wheels is 159,000 lbs., which gives an average load per axle of 53,000 lbs. The engines have 21 x 28 in. cylinders and a maximum tractive power of 33,300 lbs., which gives them a hauling capacity about equal to that of a 210,000 lb. locomotive of the 4-6-0 or the 2-6-2 type.

tures, the use of the Walschaerts valve gear on these engines gives evidence of an increasing belief among railroad men in the advantages of this type of valve motion or at least a willingness to give it a trial.

One of the points taken advantage of where Walschaerts valve motion is used is that it affords a better opportunity than the Stephenson link motion

The shell is made of two courses and the dome, which is placed toward the back of the second course, is 30 ins. in diameter. The roof sheet slopes 3 1/8 ins. toward the back and the crown sheet is parallel to it. The back sheet slopes forward at the top 13 1/8 ins. and the steam and water space above the crown sheet is about 20 ins. There are 390 two-inch flues in the boiler, each

13 ft. 7 ins. long, and these give a heating surface of 2,754.6 sq. ft. The fire box has 180.4 sq. ft. of heating surface in it and these together give a total of 2,935 sq. ft. The grate area is 52 sq. ft.

The tender is of the usual U-shaped plan and is carried on ordinary arch bar trucks. The centre sills of the frame are two 12-in. steel channels, weighing 40 lbs. to the foot, and the side sills are 10-in. channels, 35 lbs. to the foot. The tank has a water bottom and holds 7,500 U. S. gallons of water and 13 tons of fuel. Some of the principal dimensions are here appended for reference:

- Wheel base—Total, engine and tender, 56 ft. 10 1/4 ins.
- Weight—In working order, 187,000 lbs.; engine and tender, 333,000 lbs.
- Axles—Driving journals, 9 1/2 x 12 ins.; engine truck journals, diameter 6 1/2 ins., length 12 ins.; tender truck journals, diameter 5 1/2 ins., length 10 ins.
- Boiler—Working pressure, 200 lbs.
- Firebox—Type, wide; length, 108 1/8 ins.; width, 60 1/4 ins.; thickness of crown, 7/16 in.; tube sheet, 1/2 in.; sides, 3/8 in.; back, 3/8 in.; water space, front, 4 1/4 ins.; sides, 4 ins.; back, 4 ins.
- Crown staying—Radial.
- Tubes—Thickness, No. 11 B. W. G.; air pump, 11 ins. L. H. 2; reservoir, 20 1/2 x 11 1/4 ins.
- Piston—Rod diameter, 3 3/4 ins.
- Wheels—Driving material, cast steel; engine truck, diameter 33 ins., C. I. Spoke Cen.; tender truck, diameter 33 ins.

**Boiler Skimmer and Blow-off.**

The object which Mr. J. B. Barnes, superintendent of the locomotive and car departments of the Wabash Railroad, had in view when designing his boiler skimmer used in connection with his blow-off valve was the prevention of foaming, or at least of providing means for removing the cause or of lessening its effects. It is applicable to a stationary boiler as well as to that of a locomotive.

Our illustration makes clear the general form of its construction. It consists of a V-shaped trough lying round the throttle valve something in the form of the letter U. The ends of the trough have webs across so that the only way in which foamy water can get into the trough is to splash over the edges. At the bottom of the V-shaped trough and cast on as a part of it, it is a 2-inch pipe, and at the sharp angle of the V at the bottom there is a series of holes placed at intervals all along, so that whatever water splashes over the edges of the trough will drain into the 2-inch pipe which forms the base of the casting.

The whole thing hangs on slings from the dome course and the height can be regulated to suit conditions. Our illustration shows it placed so that the top of the trough is just even with the water level in the boiler when that is at the normal level opposite the centre gauge cock. The cast iron pipe at the bottom of the trough is in com-

munication with pipes leading to a pair of specially designed blow-off cocks placed outside the boiler one at either side. The trough itself is 4 3/8 ins. wide and 6 1/2 ins. high. The skim-

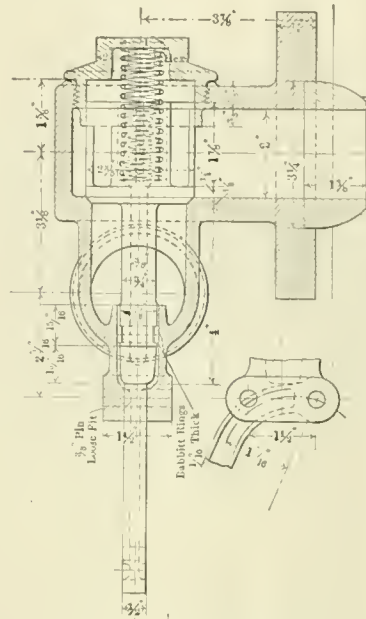

BARNES' BLOW-OFF VALVE.

mer is made in two pieces and the semi-circular end is placed around the throttle standpipe and the straight ends of the trough extend toward the front of the boiler along the dry pipe. The position and the arrangement of the skimmer are such that in the event

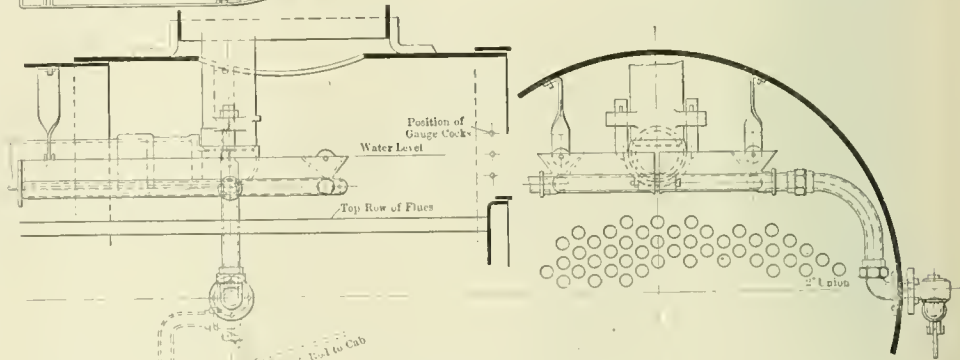
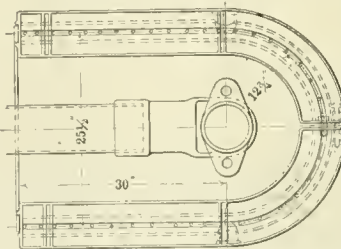

SECTION, PLAN AND END VIEW OF BARNES' BOILER SKIMMER AND BLOW-OFF VALVE.

of the water beginning to foam the uprush of steam and water to the throttle will cause most of the foaming water surrounding the stand and dry pipe to find its way into the V-shaped trough.

The blow-off valves are placed outside the boiler, one on each side, and from each a 1/2-in. iron rod extends back to the cab

and handles are placed within easy reach of engineer and fireman, who can readily relieve any foaming and priming whenever necessary. The blow-off valve complete is of brass with the exception of the lever, which is made of either malleable iron or cast steel. The valve and valve-stem are cast in one piece, the part above the seat having four wings which fit into a projection of the nut, thus forming a guide for the upper part, and the stem proper passes through the valve body, thus insuring the proper seating of the valve. A pocket is cored in the valve to receive a spring made of 1/8-in. German silver wire, 1 inch in diameter and 4 ins. high. The application of this spring makes it impossible for the valve to remain open when the lever is released. It will readily be seen that this valve can be operated on the road by the engineer or fireman without any fear of its not closing, a feature most desirable in any form of blow-off valve.

Mr. Barnes informs us that "an engine equipped with this skimmer and properly operated will make between washings eight times as many miles as other engines not so equipped. This means the saving of all expense for repairs incident to contraction and expansion in washing, which it is difficult to estimate. Any device which will keep an engine out of the round-house and in service, especially in busy times, is certainly worthy of consideration."

The skimmer is intended for use in locomotives operated in a district where the water used contains impurities likely to cause foaming or those which are found at certain periods of the year, or where by reason of the absence of scale-forming ingredients, regular water

treating plants have not been installed. The device has been tested on the Wabash and the inventor tells us that a 21x26 inch 4-4-2 type engine, which before being equipped with this device required washing out at the end of every 1,000 miles, was after the application of the skimmer able to make over 8,000 miles between washings.

# Items of Personal Interest

Mr. J. A. Best has been appointed purchasing agent of the Georgia Railroad with office at Augusta, Ga.

Mr. G. M. Ellsworth has been appointed chief motive power clerk on the Pennsylvania Railroad, at Altoona, Pa.

Mr. O. H. Cherry has been appointed assistant chief motive power clerk on the Pennsylvania Railroad at Altoona, Pa.

Mr. C. P. Diehr has been appointed master mechanic on the New York Central Railroad with headquarters at Avis, Pa.

Mr. A. Gordon Jones has been appointed purchasing agent of the Southern Railway, vice Col. J. P. Minitry, deceased.

Mr. M. H. Strauss has been appointed road foreman of engines on the New York Central Railroad, vice Mr. C. P. Diehr, promoted.

Mr. Earl Haggett has been appointed assistant superintendent of the Brooks shops of the American Locomotive Co., at Dunkirk, N. Y.

Mr. F. D. Gomware has been appointed road foreman of engines on the Wabash Railroad at Decatur, Ill., vice Mr. J. S. Sweeney, resigned.

Mr. J. Shumaker has been appointed master mechanic on the Missouri Pacific Railway at Ferriday, La., vice Mr. J. W. Ruffner, resigned.

Mr. A. W. Harvey has been appointed division foreman of the Chicago & North Western Railway with headquarters at Fort Pierre, South Dakota.

Mr. B. Donahue has been appointed master mechanic on the Missouri Pacific Railway system at Van Buren, Ark., vice Mr. F. K. Tutt, transferred.

Mr. J. G. Sullivan has been appointed manager of construction for the Eastern Lines of the Canadian Pacific Railway, with office at Toronto, Canada.

Mr. Warren Togwell has been appointed road foreman of engines on the Wabash Railroad with office at Decatur, Ill., vice Mr. J. S. Sweeney, resigned.

Mr. Bert Meyers has been appointed acting road foreman of engines of the Lima & Chicago division of the Erie, vice Mr. J. A. Cooper, transferred.

Mr. F. P. Mooney has been appointed master mechanic of the Trinity & Brazos Valley, with headquarters at Teague, Texas, vice Mr. W. C. Burel, resigned.

Mr. Harry Hayes has been appointed standard practice engineer of the Brooks shops of the American Locomotive Co., at Dunkirk, N. Y., vice J. R. Marshall, promoted.

Mr. John R. Magarvey has been pro-

moted from the position of superintendent to that of manager of the Brooks shops of the American Locomotive Co., at Dunkirk, N. Y.

Mr. P. J. Colligan has been appointed acting master mechanic on the Chicago, Rock Island & Gulf Railroad, with headquarters at Fort Worth, Texas, vice Mr. J. E. Holtz, resigned.

Mr. Herman F. Ball, vice-president of the American Locomotive Automobile Co., has become vice-president of the American Locomotive Company, in charge of mechanical engineering and designing. He also retains his connec-



HERMAN F. BALL.

tion with the Automobile branch of that corporation. Mr. Ball succeeds Mr. J. E. Sague, who was until recently first vice-president of the American Locomotive Co. Mr. Ball was for many years superintendent of motive power of the Lake Shore & Michigan Southern.

Mr. R. B. Van Horne, son of Sir William C. Van Horne, has been appointed assistant to the general manager of the Cuba Railroad, with office at Camaquay, Puerto Principe, Cuba.

Mr. S. P. Hall has been appointed engineer of signals on the New York Central & Hudson River Railroad, with jurisdiction outside of the electric zone. His office is in New York.

Mr. John Lintz, master car builder of the Lehigh Valley Railroad at Packer-ton, Pa., has had his jurisdiction extended to cover all car repairs and car shops on the company's entire system.

Mr. R. B. Watson has been appointed engineer of tests on the Erie Railroad

and of the New York, Susquehanna & Western, with office at Meadville, Pa., vice Mr. J. G. Platt, resigned.

Mr. W. L. Garland has been appointed general agent of The Safety Car Heating & Lighting Company, of New York, with office at Philadelphia, Pa., vice Mr. B. V. H. Johnson, resigned.

Mr. J. J. Flynn, general foreman of the Louisville & Nashville shops at Mobile, Ohio, has been promoted to the position of master mechanic of the company's shops in Nashville, Tenn.

Mr. E. A. Williams, formerly general mechanical superintendent on the Erie Railroad, has resigned to engage in private business. The position occupied by Mr. Williams has been abolished.

Mr. F. K. Tutt, formerly master mechanic on the Missouri Pacific Railway at Van Buren, Ark., has been transferred to Osawatimie, Kan., in a similar position, vice W. B. Gaskins, resigned.

Mr. J. J. Cozzens has been appointed assistant engineer of signals on the New York Central with office at Syracuse, N. Y. He is in charge of the installation and maintenance of signals at the western district.

Mr. R. W. Burnett, formerly master car builder of the Erie Railroad at Meadville, Pa., has been appointed assistant master car builder of the Canadian Pacific Railway, Lines East, with office in Montreal, Can., vice Mr. S. King, resigned.

Mr. R. J. Marshall, formerly standard practice engineer in the Brooks shops of the American Locomotive Co., at Dunkirk, N. Y., has been appointed superintendent of the shops, vice Mr. J. R. Magarvey, promoted.

Mr. H. W. Davies, formerly chief traveling auditor of the Atlantic & North Carolina division of the Norfolk & Southern Railway, has been appointed purchasing agent of that road, vice Mr. W. R. Burrows, resigned.

Mr. R. L. Stewart, formerly general foreman of the Kansas City Southern Railway, has been appointed master mechanic of the northern division of the same road at Pittsburg, Kan., vice Mr. W. B. Dunlevy, resigned.

Mr. Robert J. Hardie has recently been appointed the Manager of the Union Foundry and Machine Company of Valparaiso, Chile. Mr. Hardie takes the place of his brother, who recently died while in the service of that company.

Our friend Mr. F. W. Blauvelt, to whom we are indebted for many photographs which have been reproduced in the pages of RAILWAY AND LOCOMOTIVE

ENGINEERING, was the amateur artist who took Jasper Wandle's last engine, which we showed on page 132 of our March issue. He is a nephew of the late Mr. Wandle. The lad in the cab of the engine is Mr. Blauvelt's son. The underline below the half-tone did not indicate this relationship, but this is the way it is.

Mr. R. Marpole, formerly general superintendent of the Pacific division of the Canadian Pacific Railway, has been appointed general executive agent of the company for British Columbia with office at Vancouver, B. C. All legislative work, extraordinary litigation and claims affecting the company's interests in that province will come under his supervision. All applications for leases or agreements with reference to these properties will have to be submitted to him for approval. He has also supervision over exploration, surveys and the construction of new lines in the Province of British Columbia.

### Adjusting Stephenson Valve Gear.

By JAMES KENNEDY.

In the March issue of RAILWAY AND LOCOMOTIVE ENGINEERING, the common method of adjusting the Stephenson valve gearing was described as far as the preliminary setting of the eccentrics and the adjusting of the eccentric rods was concerned, and while this is generally as much as is done in a running repair or round house examination, it is by no means a complete adjustment of the gearing if it is desired to examine the action of the valves when the valve stroke is shortened by moving the reverse lever to other points of the quadrant, or "hooking" up the lever as it is called.

Assuming that the rods and eccentrics have been carefully adjusted to suit the extreme travel of the slide valves and that it is necessary to adjust the amount of valve opening or

valve by moving the engine a short distance backward and forward again to the point where the tram exactly enters the mark on the valve rod, showing that the steam port is at the closing point. The distance from the extreme front end of the crosshead to the pencil mark on the guide may not be exactly six inches, but this is immaterial. Suppose it is  $6\frac{1}{2}$  ins., this should be marked down with chalk or otherwise and the operation continued on the other side of the engine in the same way and so on until the four separate and distinct distances are discovered and marked down for reference. Suppose the right side shows  $6\frac{1}{2}$  ins. in front and  $5\frac{1}{2}$  ins. in the back and that the left side shows 7 ins. in front and  $4\frac{1}{2}$  ins. back. A general summing up of these distances would show that something near six inches would be the best average that could be obtained.

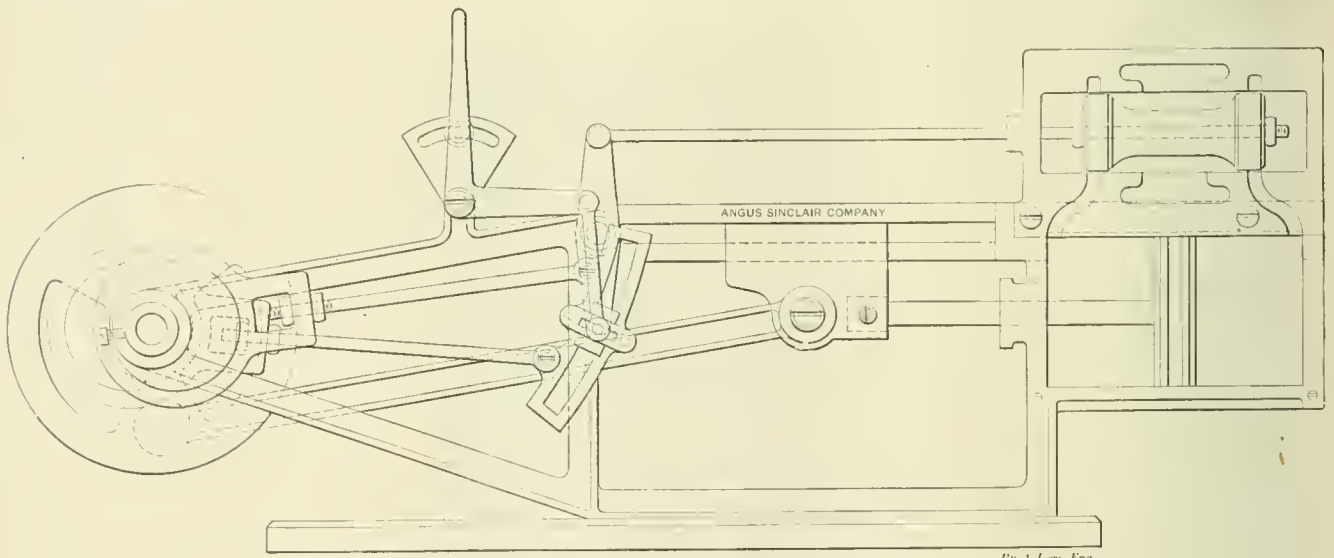

OUR MODEL OF STEPHENSON VALVE GEAR, WITH ADJUSTABLE POINT OF SUSPENSION.

### Obituary.

We have the sad duty of recording the death of James N. Weaver, which occurred at his home in Sayre, Pa., in the month of February. From 1869 to 1898 he was master mechanic on the Lehigh Valley Railroad at that point, and was well known on the road for his ability and energy in the discharge of his duties. After severing his connection with the Lehigh Valley, which he did voluntarily after many years of faithful service, he became the postmaster of the town of Sayre. He was a veteran of the civil war, was prominent in Masonic circles and was honored and respected by all who came in contact with him. He had been in failing health for several years and was in his sixty-third year when the final summons came. A large circle of friends, not only in Sayre, but among railroad men all over the country will grieve to hear that he has passed away.

travel at some hooked-up point, the common practice is to begin the operation by marking the extreme travel of the crossheads on both front and back end of the stroke. This can be readily done with a pencil marking a line on the guides. It is immaterial at what point we begin, but for simplifying the matter, suppose we begin as formerly at the right front end and, moving the engine forward until the crosshead has moved six inches from the pencil mark, the valve tram can be used to locate the position of the valve. With the reverse lever in the front notch it will be found that the front steam port is wide open. By drawing back the reverse lever the valve port is gradually closed and when the tram is exactly at the shut point on the valve rod the reverse lever latch should be dropped in the nearest notch and allowed to remain there. It is well to repeat the operation of finding the exact position of the

Now if the link saddles are not new and are already bolted in place, the only course open to remedy the variation in the cut-off is to sacrifice the exact adjustment of the eccentric rods and make such changes in raising one of the tumbling shaft blocks or lowering one of the rocker boxes as may best meet the compromise object at which we are darkly aiming.

Returning to our familiar position on the right front where the distance from the crosshead to the pencil line is  $6\frac{1}{2}$  ins., suppose we stop the engine a little before we reach 6 ins., say  $5\frac{7}{8}$  ins., and try the valve tram in order to ascertain how far we are from the valve opening mark. It will be found that there is probably  $\frac{1}{32}$  of an inch of a valve opening at this point, and it will readily be seen that if the valve rod has to move forward a short distance in order that the tram will touch the mark as desired the shortening of the

forward eccentric rod will have the desired effect. After affecting this slight change in the forward eccentric rod the crosshead distance from the pencilled lines on the guide can be again ascertained, and confining ourselves to the right side, suppose the distance at the front end shows  $5\frac{7}{8}$  ins. and at the back end the distance is  $6\frac{1}{8}$  ins., it is well to remember that a slight increase of the amount at the back end as measured from the crosshead to the pencilled line is a necessary arrangement in the case of a piston where the piston rod does not extend through the front cylinder head.

In the case of the ordinary single-ended piston the variation in steam pressure at the different ends of the piston can be readily determined by calculating the area of the piston rod and deducting it from the area of the piston. Suppose the diameter of the cylinder is 20 ins., then  $20 \times 20 \times .7854 = 314.16$  sq. ins., the area of the face of the piston. If the piston rod is 4 ins. in diameter then  $4 \times 4 \times .7854 = 12.56$  ins., the amount to be deducted from the area of the back end of the piston. This is equal to one twenty-fifth of the entire area, and in any adjustment of the valve gearing this factor of pressure area should be considered. It would be very safe, therefore, to allow the figures to stand that we have already found on the right side and turn our attention to the important variation discovered on the left side.

In this case where the difference in the measurement of the crosshead from the pencilled lines is much greater it would be inadvisable to adjust the eccentric rod so as to make up the entire difference. If we did so, it would be found that an excessive amount of lead or valve opening would occur at one end of the stroke when the reversing lever was placed at the extreme end of the quadrant and there would be no opening at the other end of the stroke. Apart from this involved problem, another one equally important arises from the variation occurring in the amount of the distances at which the cut-off occurs. Even if it were advisable to adjust the eccentric rod to equalize the distribution of the amount of distance traveled by the piston at each end of the cut-off, the total amount at each end would still be greater than the distance already equalized on the right side. Now if we will observe the angle at which the link is hanging as held by the ends of the two eccentric rods it will readily be seen that if the link could be raised or the link block be lowered the effect would be to move the lower end of the rocker arm towards the eccentrics while the valve rod would be moved a

corresponding distance in the opposite direction, thereby effecting an earlier closing of the valve.

There are two methods by which this can be accomplished. A liner can be placed between the rocker box and frame or between the tumbling shaft block and frame. The effect in both cases is alike, although both remedies should be avoided if possible. A third remedy lies in the shortening of the link hanger, but this is a delicate and difficult operation, owing to the brittleness of the ends of the link hanger, and of the three evils the readjustment of the height of the rocker box is the best. The exact thickness of the liner can best be discovered by experiment.

It need hardly be said that in the case of a new link, or new link saddle, the saddle can be temporarily adjusted and moved experimentally to the correct position. It is usual in describing the exact location of the position of the pin by which the link is suspended to produce an array of figures and selections from the alphabet to illustrate the true position of the point of suspension. The illustrations and formulas are of little use, as is well known to all who have placed the parts of the Stephenson valve gearing in position, and, in spite of the calculations having been very accurately made by the most accomplished mechanical engineers, there are almost invariably changes to be made in regard to the exact location of the link saddle pin. There are several causes that lead to this involved problem. The angular advance of the main rods, together with the same feature in the eccentric rods, have a singularly conflicting effect on the action that moves the rocker arm. It may be remarked that when the link is suspended exactly by the centre of the link the large variation in the cut-off occurring under such conditions is caused largely by the angularity of the link caused by the action of the eccentric rod that is not supposed to be in gearing, but is nevertheless affecting in a marked degree the action of the eccentric rod that is in gearing. It is usual to ascribe the variations in the cut-off to the angular advance of the main rod. This would doubtless be true if the eccentrics were set at the same point as the crank is set, but as they are set nearly at right angles to the crank the angular advance of the main rod has a corrective effect on the peculiarities of the link motion.

In common practice it is not necessary to trouble ourselves about these involved problems. They may very safely be set down as being among those that are past finding out. The effect of moving the point of link suspension can readily be seen by the most



Copy 69-C FREE

Here is a complete and interesting story of graphite and its development as a lubricant. You can not get in any other book of equal size so much information of REAL value. The experience of practical men and the experiments of scientific authorities are both given in this TENTH EDITION of

## "Graphite as a Lubricant"

making it valuable to men of practice and students of theory.

Lubrication in almost every kind of machinery is treated of. "Kinks" and "short-cut" methods discovered and used by resourceful engineers are included.

You should get this book now. Write for FREE copy 69-C.

JOSEPH DIXON  
CRUCIBLE CO.  
Jersey City, N. J.

casual observation. In the accompanying illustration showing the Angus Sinclair valve model with piston and reverse lever in the centre it will be seen at a glance that by moving the suspension point of the link, as can readily be done in the model, either forward or backward, the effect is to raise or lower the link, as the case may be, as the line of the centre of suspension is not in the same plane as the engine frames. In fact, the only points where the link is in a perpendicular position is at the two centres when the piston is at the extreme ends of the stroke. It may be noted that moving the saddle pin backward or forward affects the distribution of the cut-off and has the effect of equalizing or distorting the points of cut-off according to the direction in which the pin is moved, while moving the link saddle higher or lower upon the link increases or diminishes the distance of the cut-off point from the end of the stroke or pencilled mark. Indeed it may be remarked that in the case of a new saddle it is merely a matter of careful experiment which necessarily requires repetition, as the movement of the link saddle affects the valve opening at the extreme ends of the stroke so that the reverse lever should be placed in the end notches and the valve openings re-examined after each saddle experiment.

It might be added that after the forward cut-off has been carefully adjusted it does not follow that the backward cut-off will be found to be correct. Other changes and compromises may have to be made, but it should be noted that if we have disposed of the right and left sides of our engines and have the cut-off adjusted, say at 6 ins. in the back and 5¼ ins. in front, it is not necessary that the same figures should be established as an absolute necessity for the backward motion of the engine. It is enough that the points are equalized to each other, and while the forward and backward motions of the engine can be equalized exactly if there is a new quadrant to be made it will be found that where the notches are already made in the quadrant it will be hardly possible to arrange the cut-off points so that they will exactly correspond.

This leads us to observe what will always be noticed, that no matter how carefully the entire valve gearing may be adjusted it will be found that when the locomotive is overhauled for general repairs variations have occurred that seem to the casual observer extremely puzzling. It is common to belittle the original construction and set down the apparent errors in organic construction to a lack of ability or care in the first adjustment of the mechanism. This is a gross injustice, and if

we could only dimly discern the vicissitudes through which the mechanism has passed and measure the blows of circumstance that have fallen upon the multiplex parts of the elastic contrivance we would perhaps recognize the fact that it is remarkable that machinery so involved and so subject to disturbing influences has retained such a degree of perfection as it is often found to possess after service so peculiarly exacting and so painfully strenuous.

#### Steel Tie Filled with Asphalt.

The Pennsylvania Railroad has lately put in some new ties on the Pittsburgh division. The new ties are made of steel castings, about the size of the ordinary wooden ones. They are in the form of a box without a top and are filled with asphalt and rock, and when placed in roadbed the open face, showing the filling, is turned down and lies upon the stone ballast of the road.

Each of these ties weighs in the neighborhood of 700 lbs. and about 3,000 of them have been put in the track near Lockport. The ordinary wooden sleeper weighs about 230 lbs. The Pennsylvania are also experimenting with the steel I-beam tie, also with track laid on longitudinal girders. Efforts are also being made to preserve soft wooden ties by impregnating them with creosote, as is done in Great Britain and other countries.

#### Crucibles.

Crucibles is the title of a very neat little brochure published on the subject of graphite crucibles, which are also known as plumbago or black lead crucibles. The author of this work is Mr. John A. Walker, vice-president, treasurer and general manager of the Joseph Dixon Crucible Company, Jersey City, N. J. The purpose of the little book is to instruct users of crucibles as to the proper use of crucibles, and what may happen by the abuse of crucibles. It tells what graphite is, and why crucibles are made of it. It tells why crucibles should be made of flake graphite. It tells why some crucibles are dark and others light, and the import of that fact.

It gives rules for annealing crucibles, and tells why they should be carefully followed. It tells why it is advisable to buy crucibles in quantities. It tells of the proper shape of tongs and how they should be handled, and how the metal should be placed in the crucibles, and how the crucibles should be placed in the fire. The booklet describes the various fuels used in smelting metals, and their effect on the crucibles. It speaks of the importance of perfect combustion. The book also contains other information; it gives the proportions of metal in commonly-used alloys. It gives the freezing, fusing

# GOLD Car Heating and Lighting Co.

Manufacturers of

ELECTRIC,  
STEAM AND  
HOT WATER  
APPARATUS  
FOR RAILWAY CARS

EDISON  
STORAGE  
BATTERY  
FOR RAILWAY CAR  
LIGHTING

Largest Manufacturers in the World  
of Car Heating Apparatus

Catalogues and Circulars  
cheerfully furnished

Main Office, Whitehall Building  
17 BATTERY PLACE  
NEW YORK



and boiling points of various substances. It gives the specific gravity of various metals and other commodities. It gives the comparative values of fuels, and much other information of value in the foundry. The illustrations throughout the book are good specimens of photographic art, and the pamphlet is artistically printed and is a credit to its well known author and to the printers.

**Early Turbine Engine.**

It has just come to light that as far back as 1833 the Earl of Dundonald, a distinguished Scottish scientist, invented and patented a revolving steam turbine for locomotives and marine vessels. The recent adaptation of the invention to marine propulsion has brought the invention of the early scientist into notice, and it appears that he was the author of many remarkable inventions, not a few of which failed to be successful from the fact that they were too far in advance of their time.

In the turbine for locomotives the mechanism was extremely simple, consisting of two drums attached to the driving axle. It seems surprising that it did not meet with a greater measure of popular approval, as it certainly was simplicity itself compared with the ponderous beams and cranks that distinguished the work of other early adapters of Watt's steam engine to the locomotive. Indeed, a close examination of the printed details of the noble earl's contrivance shows a close resemblance to the turbine as now used in marine engines, with the difference that the turbine of the present day is attached to the screw shaft, while the earlier invention was attached to the paddle-wheel shaft.

**Do It Now.**

This is a motto which is constantly used more or less humorously, but it is probable that the idea contained in the little sentence was serious enough when Paget wrote: "Instead of the 'I will' of procrastination, the words should be 'I will now,' and the work should follow instantly."

There is one great essential in the art of doing it now, and that is the knowing how to do it, and there are various ways of learning how. Among these ways, the study of books has its appointed place. Reading does not give a man manual skill but the ability to work intelligently is certainly assisted by study and the desire for truth, for as Maeterlinck truly says: "No condition in life can warrant our abandoning our desire and search for the truth."

Among the aids which we can recommend to our readers are the following books:

"Machine Shop Arithmetic," Colvin and Cheney. This is a book that no person engaged in mechanical occupations

can afford to do without. Enables any workman to figure out all the shop and machine problems which are so puzzling for want of a little knowledge. We sell it for 50 cents.

"Firing Locomotives," Sinclair. Treats in an easy way the principles of combustion. While treating on the chemistry of heat and combustion, it is easily understood by every intelligent fireman. The price is 50 cents.

"Skeevers' Object Lessons," Hill. A collection of the famous object lesson stories which appeared in this paper several years ago. They are interesting, laughable, and, best of all, they are of practical value to-day. \$1.

"Standard Train Rules." This is the code of train rules prepared by the American Railway Association for the operating of all trains on single or double track. Used by nearly all railroads. Study of this book would prevent many collisions. Price, 50 cents.

"Mechanical Engineers' Pocketbook," Kent. This book contains 1,100 pages, 6x3¼ ins., of closely printed minion type, containing mechanical engineering matter. It ought to be in the bookcase of every engineer who takes an interest in engineering questions. We use it constantly as a reference for questions sent to us to be answered. Full of tables and illustrations. Morocco leather, \$5.00.

"Locomotive, Simple, Compound and Electric," Regan. An excellent book for people interested in any kind of locomotive. It will be found particularly useful to men handling or repairing compound locomotives. It is the real locomotive up to date. \$2.50.

"Simple Lessons in Drawing for the Shop," by O. H. Reynolds. This book was prepared for people trying to acquire the art of mechanical drawing without a teacher. The book takes the place of a teacher, and has helped many young men to move from the shop to the drawing office. 50 cents.

"Locomotive Running Repairs," by L. C. Hitchcock. This book contains directions given to machinists by the foreman of a railroad repair shop. It tells how to set valves, set up shoes and wedges, fit guides, care for piston packing, and, in fact, perform all kinds of work that need a thoughtful head and skilful hands. 50 cents.

"Care and Management of Locomotive Boilers," Raps. This is a book that ought to be in the hands of every person who is in any way interested in keeping boilers in safe working order. Written by a foreman boilermaker. Also contains several chapters on oil-burning locomotives. 50 cents.

"Locomotive Link Motion," Halsey. Any person who gives a little study to this book ceases to find link motion a puzzle. Explains about valves and valve motion in plain language. Price, \$1.00.

**WANTED—Engineers, Firemen, Electricians and all steam users.** Do you want to be "put wise"? Send for 52-page pamphlet containing Questions asked by the different Examining Boards throughout the country. Sent FREE. GEO. A. ZELLER BOOK CO., 21 So. 4th St., St. Louis, Mo.

**Ball's Official R.R. Standard Watches**

**16 AND 18 SIZE**

**17 and 21 Ruby Jewels, 1 Sapphire Pallets**

**Ball's Improved Safety Double Roller**



Are without question the finest watches that American talent and skilled labor can produce, and they are giving such universal satisfaction that we have no hesitancy in claiming that they are the best and safest railroad watch on the market. Tests severe and numerous have proven this fact to the most critical

users in all sections of the country, to which thousands of good Railroad and Brotherhood men are ready to certify.

We have so authorized agent to nearly every railroad center. Call on him for information and facts. Write us for descriptive matter.

**The Webb C. Ball Watch Co.**

**Watch Manufacturers  
Ball Building, Cleveland, Ohio, U. S. A.**

**METAL PRESERVATIVE PAINTS AND PRIMER**

for locomotives, boilers, stacks, front-ends, gearing, framework, metal roofs, etc.

Tell us your needs.

Metal preservative paints have been our specialty for 27 years.

Paints for all conditions.

**THE STANDARD PAINT CO.**

Sole Manufacturers

100 William St., New York

CHICAGO

ST. LOUIS

RAILWAY AND LOCOMOTIVE ENGINEERING is a practical journal of railway motive power and rolling stock, and it is so not only in name but in reality. By reading it you get a knowledge of what others think and do. \$2.00 per year; bound volumes; \$3.00.

**Electric Night at the N. Y. Club.**

A very interesting meeting of the New York Railroad Club was recently

steam locomotives and the advantages were only such as were of limited value in congested districts. He concluded an able address by stating that he believed that the time was very far distant when the steam locomotive would give place to the electrically driven engine.

Mr. Walter C. Kerr and Mr. F. J. Sprague also made interesting addresses presenting an epitome of the

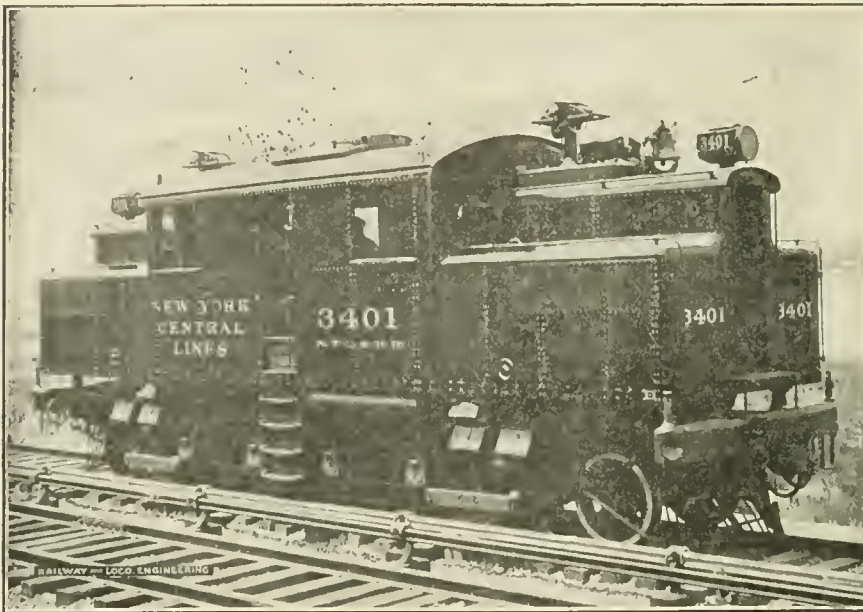

NEW YORK CENTRAL ELECTRIC LOCOMOTIVE.

held at the Club's new rooms in the building of the Engineering Societies, Mr. H. H. Vreeland, presiding. The proceedings took the form of a series of short addresses by men of prominence in railroad matters, each giving his views on some phase of heavy electric traction that had received particular investigation at his hands. Mr. W. J. Wilgus, vice-president of the New York Central Railroad, was the first speaker, and presented a brief history of the introduction of electric traction on the company's tracks in and near New York. He claimed that the work had been the result of nearly three years' experimenting, and that during that period every kind of test had been made with the most satisfactory results. He presented a report of the recent disaster, whereby over twenty people had lost their lives by the derailment of a train of cars drawn by electric locomotives. Mr. Wilgus deplored the accident, but carefully refrained from venturing any opinion as to the cause of the disaster. Mr. George Gibbs, of the Pennsylvania Railroad, presented in a very concise manner the advantages and disadvantages of electric locomotives. He claimed that the cost of installation and maintenance of electric locomotives was nearly double that of

progress made in recent years in electric installation. Mr. T. Varney reported on the overhead methods in vogue and made special reference to the construction and operation of the

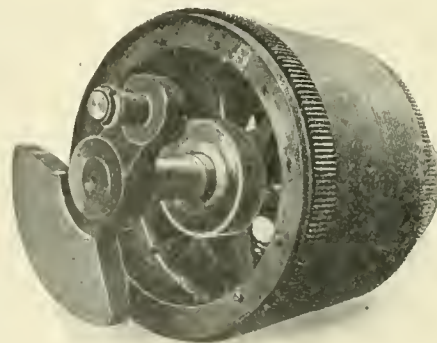

ARMATURE OF THE SIMPLON ELECTRIC LOCOMOTIVE WITH DRIVING PIN TO WHICH CONNECTING ROD IS ATTACHED.

Simplon Tunnel, which many experts claim to be the best system of electric traction now in use. The details of this system will be found in another column of this issue of RAILWAY AND LOCOMOTIVE ENGINEERING. Mr. W. B. Potter spoke very ably on the difficulties in establishing a complete electric

**JUST PUBLISHED**  
**The Walschaert**  
**Locomotive Valve Gear**

By W. W. WOOD.

Nearly 200 pages.

Fully Illustrated.

**PRICE \$1.50**



The only book issued that is devoted exclusively to the Walschaert Valve Gear, and it fills a demand which, during the last few months, has become very important. If you would thoroughly understand the Walschaert Valve Gear you should possess a copy of this book, as the author takes the plainest form of a steam engine—a stationary engine in the

rough, that will only turn its crank in one direction—and from it builds up—with the reader's help—a modern locomotive equipped with the Walschaert Valve Gear, complete.

The points discussed are clearly illustrated; two large folding plates that show the position of the valves of both inside or outside admission type, as well as the links and other parts of the gear when the crank is at nine different points in its revolution, are especially valuable in making the movement clear. These employ sliding cardboard models which are contained in a pocket in the cover.

The book is divided into four general divisions, as follows: I. Analysis of the gear. II. Designing and erecting the gear. III. Advantages of this gear. IV. Questions and answers relating to the Walschaert Valve Gear, which will be especially valuable to firemen and engineers preparing for an examination for promotion.

*Just Issued—1907 Revised and Enlarged Edition.*

UP-TO-DATE

**AIR BRAKE CATECHISM**

By ROBERT H. BLACKALL.

**PRICE \$2.00**

*The Standard Book on the Air Brake. Contains over 2,000 Questions and Answers giving a detailed description of all the Old Standard and Improved Equipment.*

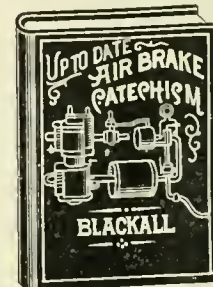

Owing to the many changes and improvements made in the Westinghouse Air Brake it has been found necessary to issue the new, revised 1907 edition of the Air Brake Catechism, which contains all the latest information necessary for a railroad man to pass his

examination on the new as well as the older style of brake.

The new revised 1907 edition is right up to date and covers fully and in detail the Schedule E. T. Locomotive Brake Equipment, H-5 Brake Valve, SF Brake Valve (Independent), SF Governor Distributing Valve, B-4 Feed Valve, B-3 Reducing Valve, Safety Valve, K Triple Valve (Quick-Service) Compound Pump.

Send for a special circular of these books as well as our Other Railroad Books. Copies of these books sent prepaid on receipt of price.

**Agents Wanted** Write for our special terms. You can make equal to a month's pay selling our books on the side.

**The Norman W. Henley Publishing Co.**  
132 Nassau St., New York, U. S. A.



SCHOOL BUILDINGS OCCUPIED ENTIRELY BY THE I. C. S.



# The Business of this Place is to Raise Salaries

That sounds queer, doesn't it? And yet there is such a place in reality—The INTERNATIONAL CORRESPONDENCE SCHOOLS, of Scranton, Pa., an institution the entire business of which is to raise, not merely salaries—but YOUR salary.

To achieve that purpose, the I. C. S. has a working capital of many millions of dollars, occupies three large buildings, covering seven acres of floor space, and employs 2,700 trained people, all of whom have one object in view—to make it easy for you and all poorly paid men to earn more.

Every month an average of 300 I. C. S. students voluntarily report increased salaries. In 1906, 3,200 students so reported. These students live in every section. Right in their own homes, at their present work, the I. C. S. goes to them, trains them to advance in their chosen line, or to profitably change to a more congenial occupation.

The same opportunity now knocks at your door. What are you going to do with it? Are you going to lock the door in its face and lag along at the same old wages, or are you going to open the door and give the I. C. S. a chance to show you?

## To Raise YOUR Salary

Select the position you wish to secure, write a postal to the INTERNATIONAL CORRESPONDENCE SCHOOLS, Box 805, Scranton, Pa., and ask how you can qualify to fill it at a good salary. Be sure to mention the position you prefer.

General Foreman R. R.	Electrical Engineer
R. R. Shop Foreman	R. R. Con. Engineer
R. R. Trav. Engineer	Civil Engineer
R. R. Trav. Fireman	Bridge Engineer
Locomotive Engineer	Chemist
Air-Brake Instructor	Mining Engineer
Air-Brake Inspector	Architect
Air-Brake Repairman	Bookkeeper
Mechanical Engineer	Stenographer
Mechanical Draftsman	Ad. Writer

outfit suitable for railways, but looked hopefully to the future.

Mr. S. M. Vaucrain, superintendent of the Baldwin Locomotive Works, made a very happy and telling address which was warmly received by the members. Mr. Vaucrain playfully ridiculed the arrogance of electricians generally and the designers of electric locomotives particularly.

supported upon the driving wheels a much greater percentage of the total load of the machine is not above the springs. Mr. Vaucrain is in favor of removing motors entirely from any direct connection with the wheels, and making them a firmly fixed part of the locomotive itself, and transmitting power from the motors to the driving wheels by a system of connecting or

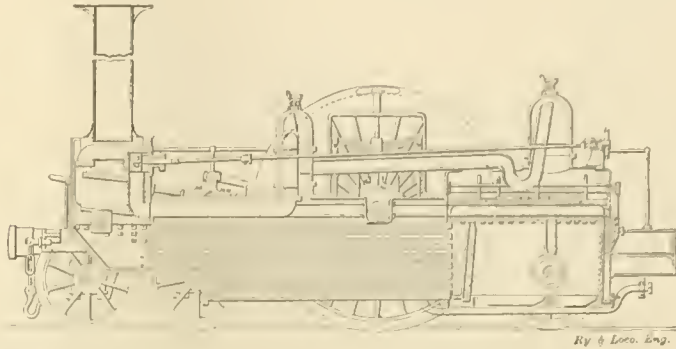

TREVITHICK'S ENGINE "CORNWALL," 1847. DRIVING AXLE CARRIED OVER BOILER TO GIVE LOW CENTRE OF GRAVITY.

In the opinion of Mr. Vaucrain, if the electric locomotive designer would follow the fundamental principles that underlie construction of steam locomotives for high speeds, there would be no difficulty in operating electric locomotives for equally high speeds. The difficulty is that such a motor does not exist, or at least one of sufficient size to give such speed cannot be had.

All who have had anything to do with the designing or management of steam locomotives for high speeds are aware that no success was had until

driving rods similar or substantially the same as is now used on steam locomotives. In the Simplon tunnel, electric locomotives are so arranged and give most satisfactory service. (In our illustration we show the rotor or armature, with driving pin to which is fastened one end of a connecting rod, the other end of which is attached to crank pin on the driving wheels, as in steam locomotives). The only reason why this has not been done in this country is that the electric people so far have not felt able to produce sufficiently powerful locomotives;

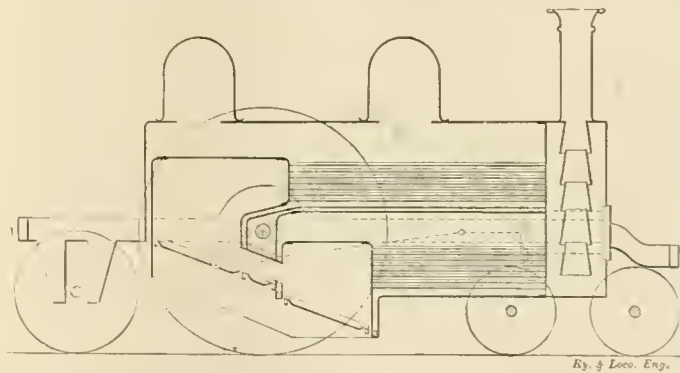

COLBURN'S DESIGN, AXLE THROUGH FIREBOX FOR LOW CENTRE OF GRAVITY.

the driving wheel was proportioned to the speed. When this was done, trouble and annoyance from high rotative speeds were removed. The center of gravity was raised higher and higher, and what was first thought would be a detriment to the operation of the locomotive at high speed was afterward found to be of great benefit, not only to the locomotive itself but to the roadbed.

In electric locomotives, where the armatures are placed upon the axles or

still to fix the motor in some manner to the driving engine.

Mr. Angus Sinclair said: "We have been very much interested in the remarks made by Mr. Vaucrain. I particularly sympathize with him, entertaining the same views, especially relating to the center of gravity. I think the designers of electric locomotives ought to be guided in some measure by the experience of those who developed or designed the steam locomotive. In

the early days of steam locomotives there was a belief that it was necessary to have the center of gravity as low as possible. There were all sorts of peculiar appliances used to get the center of gravity down low. There were boilers placed below the driving

perence with small wheels, we may say multi-coupled wheels such as are used on consolidation engines. When consolidation engines first came out, there was a belief that they were destructive to the track owing to their unbalanced revolving weights. But greater experi-

# Tate Flexible Staybolt

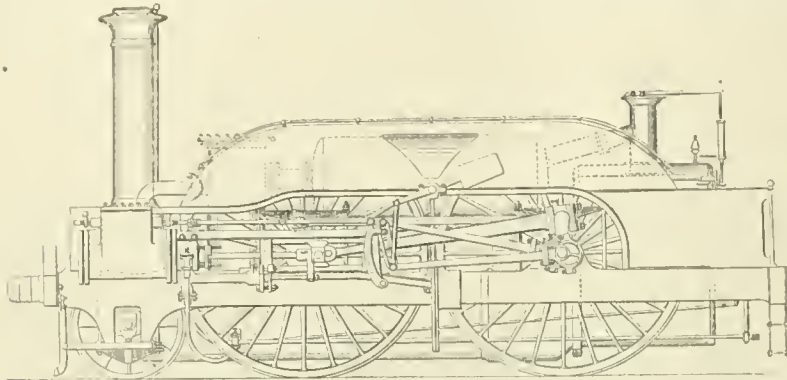

FRENCH ENGINE "L'AIGLE," 1855. SEGMENTAL BOILER. USED TO PRODUCE LOW CENTRE OF GRAVITY.

axles, and boilers were placed behind the driving wheels, and all sorts of things were done to produce an easy riding engine and one which would not be hard on the track. The opposite was found to be the effect. The action of locomotives having a low center of gravity was found to be more injurious to the weak strap-rails and other fragile rails used in those days than the engines having a high center of gravity. Pioneer

ence with the consolidation, or eight-wheel connected engine, showed that the greatest damage was done by the side thrusts of the low wheels. That was finally acknowledged and that is why there are so few consolidation engines used to-day, with very small driving wheels.

"When the Wootten locomotive first appeared there was a good deal of alarm because it was thought to be a dangerous engine with its high center



Strong

Effective

Economical

Flexibility

Durability

Simplicity

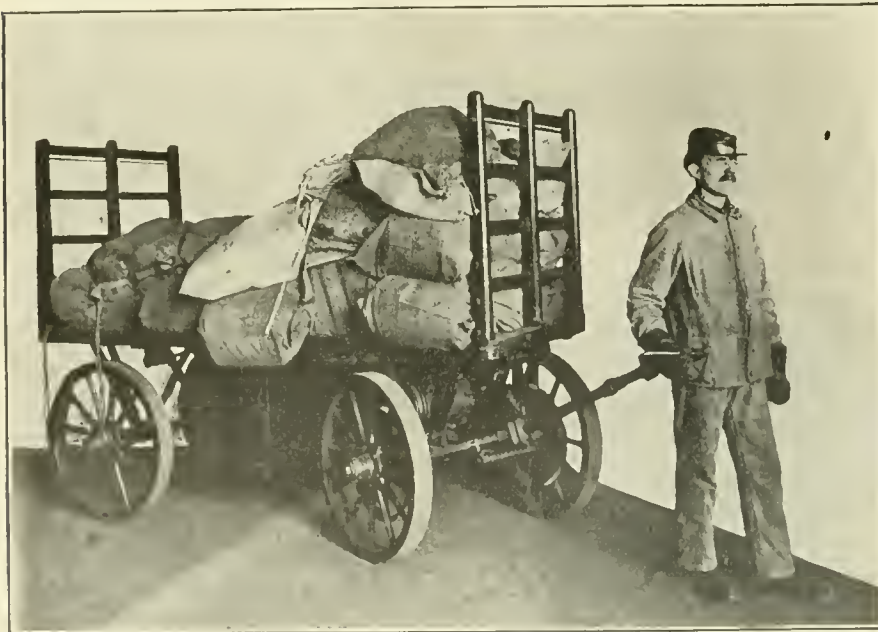

BAGGAGE TRUCK CARRYING MAIL. ATTENDANT ONLY HAS TO START, STOP AND STEER, THE MOTOR PROPELS.

builders never attained the height we have had of late years, but their experience was that an engine with a low center of gravity was a rough riding engine in itself, and one that would damage the track, owing to the side thrusts that it transmitted.

"We have all had more or less ex-

perience with small wheels, we may say multi-coupled wheels such as are used on consolidation engines. When consolidation engines first came out, there was a belief that they were destructive to the track owing to their unbalanced revolving weights. But greater experi-

Holds firebox sheets securely together, and accommodates itself to the unequal expansion of the plates.

## FLANNERY BOLT COMPANY

PITTSBURG, PA., U. S. A.

Suite 308, Frick Bldg.

B. E. D. STAFFORD, - - General Manager  
Write us for Reference Book

# Homestead Valves

Straightway, Three-way and Four-way, and

# Homestead Locking Cocks

Are Famous World Over

They cost more, but are worth very much more than other makes. You try them and see.



Brass, 1 1/2 in.

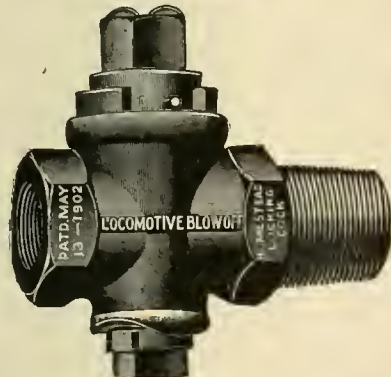

Iron Body, Brass Plug, 1 1/2 in.

**HOMESTEAD VALVE MFG. CO.**

WORKS: HOMESTEAD, PA. PITTSBURG, PA.

## American Locomotive Sander Company

13th & Willow Sts., Philadelphia, Pa.

Proprietors and Manufacturers

LEACH, SHERBURNE, DEAN, HOUSTON, "SHE" and CURTIS

**SANDERS**

**THE ROBERT W. HUNT & CO.**

Bureau of Inspection, Tests and Consultation. 1137 THE ROOKERY, CHICAGO.

66 Broadway, New York. Park Building, Pittsburg.

31 Norfolk House, London, Eng. Inspection of Steel Rails, Splice Bars, Railroad Cars, Wheels, Axles, etc. CHEMICAL LABORATORY—Analysis of Ores, Iron, Steel, Oils, Water, etc. PHYSICAL LABORATORY—Test of Metals, Drp and Pulling Test of Couplers, Draw Bars, etc.

Efficiency Tests of Boilers, Engines and Locomotives.

Now I do not see why the designers of electric locomotives should not take a lesson from what the steam locomotive engineers have gone through. Electric locomotives certainly have been running at a very high speed with a low center of gravity, and I believe that what has been found true of steam locomotives is going to be found true with electric locomotives."

### Automobile Baggage Trucks.

There have been placed in use in the Broad Street station of the Pennsylvania Railroad in Philadelphia, baggage and

respect they have proved satisfactory. Their speed is controlled from a small lever fastened on the tongue by which they are steered, and it is further arranged so that if this tongue is dropped or let down the current is shut off and the brakes are put on. A catch is also provided, so that the tongue can be fastened up against the front of the truck, in which position the current is also shut off and the brakes are held on the same as when it is on the ground.

Four of these trucks are now in use, three built by the Pennsylvania Railroad and one by an outside concern



AUTOMOBILE BAGGAGE TRUCK USED ON THE PENNSYLVANIA.

mail trucks which are in themselves miniature automobiles. Those in use now are, in a sense, experimental, but the satisfaction which they have given points clearly to the fact that they will ultimately take the place of the old hand-pulled trucks in the larger stations.

It often happens that a passenger does not deliver his trunk in the baggage room until five minutes or less before train time. It is not an uncommon thing to see several baggage porters pushing and tugging at one ordinary heavily loaded hand truck in their effort to deliver its burden within the allotted time. To-day one may be attracted by a heavily loaded truck running along at a good speed and guided by a man who holds the tongue and starts it simply by pushing a button.

The general appearance of the trucks is similar to that of the old hand-pulled ones, but beneath the platform are boxes containing a storage battery and one electric motor.

It is important that these trucks must neither run away nor get beyond control if accidentally left standing. In this

The Smooth-On Manufacturing Company, of Jersey City, N. J., have issued in very readable form, the address recently delivered by the company's president, Mr. Samuel D. Tompkins, before the Modern Science Club of Brooklyn, N. Y. Mr. Tompkins explained that Smooth-On is an iron cement. It is a metallic, atomized iron in a compound that hardens when saturated with water and thoroughly kneaded into a compact homogeneous mass and when put into a hole, crack or small crevice fills it with iron that lays up to the surface so close that the slight expansion of the cement forces it into the grain of the iron.

As an example of some work done by this substance, Mr. Tompkins said: "When the seven million gallon centrifugal hydraulic pump in the New York Navy Yard collapsed, with a crack 20 feet long and it was ascertained from the makers of the pump that it would take 26 weeks to procure duplicate castings to replace the broken parts, it was suggested by the engineer in charge who had used Smooth-On Cement successfully,

that he believed he could repair it with this cement and permission was given. It was repaired successfully in three days and worked during the past six years."

The new catalogue recently got out by the Smooth-On Company, as well as the copy of this very interesting address will be supplied by the company for the asking.

#### Fulton Knows It Well.

"Do you know what is the matter with Windbag Fulton?" said the hostler to Jimmy French, the fireman of 418, as he shut off the injector with a "chunk." "No," said Jimmy, "except that when he goes to tell you anything his coal all drops through his grate, and you never get either steam or smoke out of him."

"Oh, you miss the whole point," said the hostler, in the tone of a man who believes himself to be a fine judge of character. "The trouble with Fulton is that when he hears anything he tries to match it with some stuff out of his own box. If any one has seen anything wonderful anywhere all over the whole wide world, Windy lets on he is quite familiar with the locality. Do you know, if he heard Satan himself describing the infernal regions, Fulton would say, 'That's so; I've run on the Hell Central for years and know the place well.'"

#### Tool Holder.

We have received a circular recently issued by the Armstrong Brothers Tool Company of Chicago, describing their improved lathe tool post. This company is generally spoken of familiarly as "The Tool Holder People." The lathe tool post is a good tool holder and combines

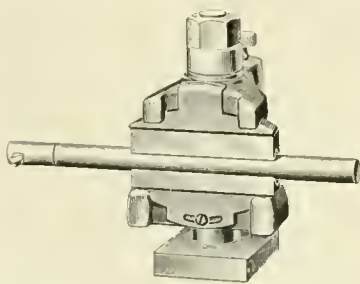

SIDE VIEW OF TOOL POST.

the strength and holding power of the strap and stud tool clamp, with the convenience of the "open side" and ordinary set screw tool post. It has no side projection and is therefore adapted to working close up to the chuck. It has also a large range of adjustment without loss of power as the rocker jaws adjust themselves on parallel lines. The open side in the post permits of rapid and convenient change and adjustment of tools for various uses. This post is so made that it does not cut or injure the tool shank and is therefore well adapted for use of tool holders. The body and jaws

are of drop forged steel, hardened, and the other parts are made of bar steel. A copy of the circular, containing prices, will be sent to any address on application to the company, 104-24 North Francisco avenue, Chicago.

#### General Foremen's Association.

The regular annual meeting of the International Railway General Foremen's Association will be held at Chicago on the 14th of May, 1907. Mr. E. C. Cook is the secretary, and his address is 405 Grand Central Passenger Station, Chicago, Ill. Below we give the topics for discussion at the coming meeting.

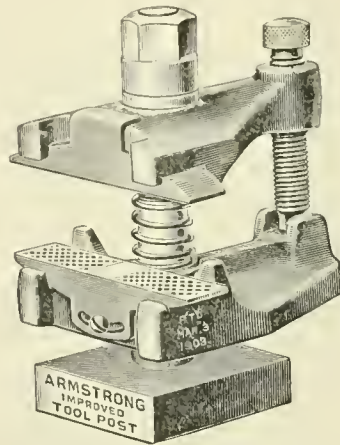

STEEL TOOL POST FOR LATHE.

with the names and addresses of the members of the various committees who are to prepare the reports.

1. Shop Betterment: How Can Output of Shops be Increased by Reconstruction of Old Machine Tools, Maintenance and Proper Distribution of Small Tools, Care of Air Tools, the Manufacture and Standardizing of New Tools, Special Devices, Jigs, Templates and Use of Same. The Necessity of Having One Main Tool-Making Plant for Large Railway Systems and Distribution of Tools to Outlying Points. The Committee are as follows: C. E. Hanse, Seaboard Air Line Railway, Savannah, Ga.; Robert C. Hyde, Toledo, St. Louis & Western Railroad, Frankfort, Ind.; Lee R. Laizure, Erie, Hornells, N. Y.; William Rose, Wabash Railway, St. Louis, Mo.

2. Piecework: Its Relation to Cost of Output as Compared with Other Advantages of Standardizing and Centralizing of Work at One Point as a Manufacturing Feature of Railroad Work and Supplying of Outlying Points with Finished Material. The Committee are as follows: W. S. Cozad, Erie Ry., Meadville, Pa.; L. H. Raymond, New York Central, W. Albany, N. Y.; C. H. Voges, Big Four, Bellefontaine, Ohio; O. F. Herold, Chicago, Burlington & Quincy Ry. Co., Holyoke, Colo.

## MASTER CAR BUILDER

### IS OPEN FOR ENGAGEMENT

Young, Active, used to Big Propositions; Capable of Installing Piece Work; Steel Car Work Handled; Not Afraid of Hard Work.

Further Particulars by Addressing

**J. R. P.**

Care **ANGUS SINCLAIR CO.**  
136 Liberty Street, New York

## THE UNION SWITCH & SIGNAL COMPANY

CONSULTING  
AND MANUFACTURING  
SIGNAL ENGINEERS

Automatic Block Signals—Electric  
and Electro-Pneumatic

Interlocking—Electric, Electro-  
Pneumatic and Mechanical

Electric Train Staff Apparatus

General Offices and Works at  
**SWISSVALE, PA.**

#### DISTRICT OFFICES:

NEW YORK - - 143 Liberty Street  
CHICAGO - - - Monadnock Block  
ST. LOUIS - - - Frisco Building

## THE TANITE CO. seeks the support of Railroaders because:

The man who uses a TANITE wheel will find it safe. Because pay for a TANITE wheel secures the greatest productive capacity. Because TANITE MILLS EMERY is mined in America and appeals to all who earn wages in America Because TANITE grinding machines are practical.

THE TANITE CO. sells Emery, Solid Emery Wheels, Buffing Lathes, Guide Bar Grinders, Car Brass Grinders, Bench and Column Grinders, Surfacing Machines, Open Side Emery Planers, Saw Gummers, Automatic Planer Knife Grinders, Diamond Tools, Polishing Paste for Brass and Nickel, Emery Wheel Cutters and Dressers.

The Tanite Co. builds special machines  
for special wants

**THE TANITE CO.**  
STROUDSBURG, PA

## Locomotive Blow-Off Plug Valves

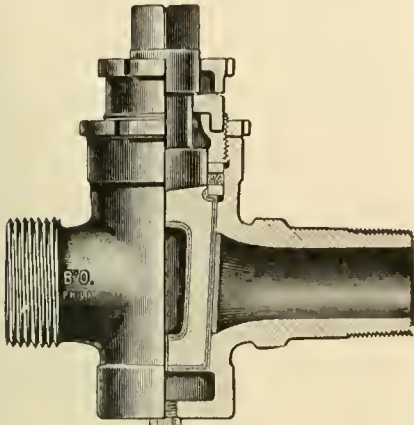
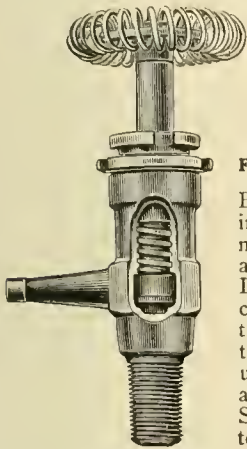

Fig. 9.

All Brass, extra heavy, with Cased Plug. For 250 lbs. pressure. Made with Draining Plug to prevent freezing.

## Locomotive Gauge Cocks



For High Pressure

Bordo Self-Grinding Gauge Cocks, made with renewable Hard Bronze Disc. Opened and closed with a quarter turn. Guaranteed Steam tight under the most exacting conditions. Shanks Threaded to specifications for Locomotives.

Fig. 23, with Wheel.

## Swing-Joints and Pipe Attachment



Fig. 33.

May be applied between Locomotive and Tender. These Swing-Joints are suitable for Steam, Gas, Air, Water or Oil.

Complete Booklet on Application  
**L. J. BORDO CO.**  
PHILADELPHIA, PA.

3. Individual Effort System: The Relations of Wages, Including Special Rewards Whether Piece Work or Other Methods, to Cost of Output. The Plan of Allowing Each Worker, Including Foreman, to Determine His Own Rate of Pay. The Committee are as follows: D. E. Barton, Santa Fe, Topeka, Kan.; S. A. Moore, Chicago, Rock Island & Pacific Ry., Chickasha, I. T.; Elton F. Fay, Union Pacific R. R., Cheyenne, Wyo.; Wm. E. Farrell, Big Four, Delaware, Ohio.

4. The Relation of the Store Department to Shops. Necessity of Store Department Being in Close Touch and in Harmony with the Mechanical Department. The Anticipation of Their Wants and Preparedness to Supply Them. The Shop Stock Room and Proper Care of Distribution of Material to Special Gangs. Manufacture of and Care of Finished Standard Parts and Distribution to Outlying Points. The Committee are as follows: G. W. Keller, Norfolk & Western Ry., Portsmouth, Ohio; Thos. L. Drew,

Including the Various Types of Buildings, Location. Conditions to be Considered, Fuel Used in Engines, Methods used for Heating and Ventilating, Various Styles and Location of Fans and Application of Power, Cost of Plants, Influence on Personnel of Employees and Aid to Facilitate Repairs, Loss of Time Considered, etc. The Committee are as follows: George H. Gates, Louisville & Nashville R. R., Mobile, Ala.; J. W. Crysler, Chicago & North Western Ry., Milwaukee, Wis.; T. H. Ogden, Chicago, Peoria & St. Louis Ry., Springfield, Ill.; S. B. Clay, Frisco Ry., Fort Smith, Ark.

### Steel Postal Car on the Erie.

The first steel postal car ever built in this country left New York May 20, 1905, over the Erie Railroad and has since been in service on that line. Its utility has been so successful that two more have been ordered and will be in service in a short time. This car was inspected on the date mentioned by



ALL STEEL POST OFFICE CAR ON THE ERIE.

Baltimore & Ohio R. R., Connellsville, Pa.; J. R. Crowley, Central of Georgia Ry., Macon, Ga.; W. Polhman, New York, Ontario & Western Ry., Middletown, N. Y.

5. The Lagging of Boilers, Material for High and Low Steam Pressures, Covering of Cylinders and Cylinder Saddles, and All Steam Passages Exposed to Atmosphere, with Proper Jacketing of Boilers, Including Fireboxes, Blackheads, Smoke Arches, etc. The Committee are as follows: W. H. Graves, Hicks Loco. & C. Works, Chicago Heights, Ill.; E. G. Bryant, International & Great Northern R. R., Mart, Texas; F. Nelson, New York Central Lines, W. Albany, N. Y.; John F. Lawler, Chicago, Burlington & Quincy Ry., Sheridan, Wyo.

6. Ventilation of the Roundhouse.

Superintendent Bradley of the Railway Mail Service and was then put on its regular run between New York and Chicago.

The Cleveland City Forge and Iron Company have issued an elegant leather-bound hand book presenting information and tables relating to manufactured round and square bars, such as Turnbuckles and Clevis nuts. The work will be found to be particularly useful to engineers and builders in the direction of its scope. The dimensions of the turnbuckles and other work, their weight in pounds, and every detail is furnished in the handiest possible form. The illustrations that accompany the text leave nothing to be desired, and the work, in addition to the sixty pages of printed matter, has a convenient section of blank sheets forming a handy

This illustration shows the form of construction of the

## Dart Patent Union

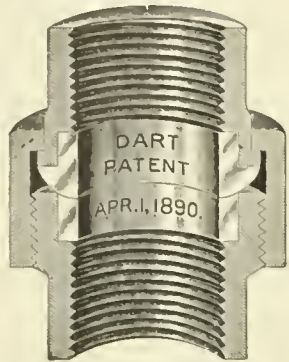

Every feature of construction represents the best points to insure stability and durability. The malleable iron pipe ends and nuts, in combination with bronze metal seats, are as near perfection as is possible to approach, and the sales to date indicate the public approval. There are none so good. For sale by all the principal jobbers in United States, Canada and Europe.

**E. M. Dart Mfg. Co., Providence, R. I.**  
FAIRBANKS CO., SALES AGENTS.

**MICA**  
CABOOSE LAMP CHIMNEYS

Save 50 per cent.

**STORRS MICA CO.,**  
R. R. Dept. Owego, N. Y.



## The Twentieth Century Master Mechanic

Won't use Solid Mandrels.  
Cost too much, take up too much  
room and don't give satisfaction.

### Nicholson Expanding Mandrels

Take everything from 1 to 7 inch  
holes. Take up little room—  
always ready and you can buy  
four sets for the cost of one of  
the solid kind.

### Are You Using Them?

Catalogue tells you  
more about them.

**W. H. Nicholson & Co.**  
Wilkesbarre, Pa.

notebook. Copies may be had on application at the company's works or at the New York office, No. 11 Broadway.

#### Pay Increased.

It is reported that the assistant general manager of the Lake Shore and Michigan Southern Railway, Mr. D. C. Moon, has been in conference with Mr. Warren Stone, chief of the Brotherhood of Locomotive Engineers regarding the pay of the engineers. An agreement has been reached by which the men will receive an increase ranging from 10 to 18 per cent., according to the kind of engine handled and the service performed. The increase will amount in the aggregate to more than \$100,000 per annum.

#### Light Locomotives.

A pamphlet recently issued by the American Locomotive Company illustrates and describes light locomotives, both steam and compressed air, adapted for the use of contractors, mines, logging roads, plantations and industrial plants and for a wide range of service on light rails and poor roadbed. The pamphlet contains 31 illustrations of different designs and types and on the page opposite each illustration is a table giving the principal dimensions of the designs and the weights and hauling capacities of the types illustrated. The last part of the pamphlet is devoted to engineering data and contains a number of very useful tables and formulas. The pamphlet is a complete record of the production of the company in locomotives of light power. It may be had on application to the locomotive company.

#### High Class Steel Tires.

The so-called "bursting" of a locomotive tire on the Long Island Railroad one day last month was considered of sufficient consequence to be telegraphed all over the world. When we consider the number of steel tires in use on locomotives and cars, the rarity of breakage is a high compliment to the railroad companies that purchase the high class material which forms the best guarantee against fractures. The species of dear cheapness which leads to the selection of inferior material for many purposes does not seem to have contaminated the purchasers of tires. In one respect there is a standard of excellence set up by one manufacturer of steel tires that has to be lived up to by all others. This is the product of the Krupp Works of Germany. These works were among the first to make steel tires, and they gave entire satisfaction from the beginning. American manufacturers of tires have aimed to produce something as good as the

Krupp tires and they are still engaged on this highly laudable line of competition.

#### Seats for Machinists.

It seems to shock the prejudices of an old machinist to see people gravely recommending that a machinist should be provided with a seat while doing his work. Yet that seems to be a growing fashion. A machine shop foreman writes to the *American Machinist*:

"All those in my department are allowed stools and they use them whenever the work will permit.

"I began by stopping at each machine a few moments every day and getting acquainted with the men, their likes and dislikes, their ideas as to how the tools were working and improvements that some thought could be used with advantage. In the evenings I went to each one before the bell rang to quit and inquired how they were feeling. Some would be pretty tired, others were about ready for their supper and a few were thinking of the good time they would have that night at some party or dance.

"Two of the men were running machines which required the use of both hands continually turning the handles, and of both feet to brace themselves, both being in a standing position. After pulling those handles around all day and having the weight of their bodies to support also, these two men were quite tired when night came.

"After watching them for some time I decided to try stools for those machines as well as for the others. I asked them what they thought of it, and they replied that anything which would not make the work more difficult to do would suit them.

"I explained to them that I thought a stool which was just high enough to allow of their weight resting on the edge of the seat, so that they could just reach the floor and have sufficient weight on their feet to properly brace themselves while operating the machines, would be just the thing and that because of their not having to support the weight of their bodies all day, they would not be so tired at night.

"I never saw men more pleased than were those fellows after they had used the new seats and found how much they helped them in getting their work out. They both turned out about 10 per cent. more work and felt better for it as it was the means of my getting them a raise in their wages."

A form of taper boiler is being fitted to all Great Western Railway engines as new engines are required. This form of boiler has been in use on the Taff Railway for nearly thirty years for engines employed on steep gradients.



**STANDARD MECHANICAL BOOKS  
FOR ROAD AND SHOP MEN  
BY CHAS. McSHANE.**

**The Locomotive Up to Date**

Price, \$2.50

**New York and  
Westinghouse Air Brakes**

Price, \$1.50

**One Thousand Pointers for  
Machinists and Engineers**

Price, \$1.50

All books bound in fine cloth.

AGENTS WANTED everywhere; write for terms and descriptive circulars. Will be sent prepaid to any address upon receipt of price.

**GRIFFIN & WINTERS**

171 La Salle Street, CHICAGO

**TOOL  
STEEL**

**Die Blocks  
Steel Forgings**

First Prize awarded at the Louisiana Purchase Exposition, at St. Louis, for our **TOOL STEEL** when placed in competition with the best makes in England and Germany.

Write for Information and Prices.  
Specify McInnes Tool Steel when ordering.

**McINNES  
STEEL CO.**

CORRY, PA.

The H. K. Porter Company, of Pittsburgh, Pa., have issued the ninth edition of their elaborate book descriptive of light locomotives. The work extends to 240 printed pages and embraces a comprehensive presentation of their work, which is generally recognized as an exclusive specialty in the construction of light locomotives. Besides the special designs, beautifully illustrated in the publication, there are endless modifications of locomotives built for special purposes, and in this particular the firm is growing rapidly in popular favor. It may be stated that at the present time there is an average of one locomotive each day of the year turned out complete at the company's works. Many excellent features have developed in the course of the company's long and varied experience. One fine feature, which it would do well to imitate, is the fact that the company has always on hand a number of finished locomotives, so that contractors and others need not suffer from vexatious delays. Copies of this

one of the ponderous drawings that expands the sheets into the network form, it will result in a mass of broken strands. When a sheet of expanded metal is produced without any broken strands it is necessarily a guarantee of its high quality.

The American Locomotive & Sander Co. have just issued a finely illustrated catalogue descriptive of their single, double and triple Sander. The growing popularity of the apparatus is such that proof of its good qualities comes from every quarter. Not only is the operation of the appliance such as to insure a constant and regular supply of sand when required, but the long standing trouble in regard to the clogging of the valves and attachments has been overcome. The apparatus can be readily attached to any kind of sand box. Adjustable nozzles render the apparatus serviceable for any condition. The catalogues will be sent free upon application to the company at 13th and Hamilton streets, Philadelphia, Pa.



ROLLER LIFT BRIDGE. CHICAGO TERMINAL TRANSFER RAILROAD.

fine book may be had free, and while the work is particularly intended for those who may be interested in light locomotives, it contains much valuable information in regard to the details of railway construction.

**Jersey Central Warehouse.**

One of the largest railroad warehouses ever built on the Atlantic Coast is nearing completion in Newark, N. J. The building is 360 feet long and 180 feet wide and rises to seven stories. It is being erected to carry loads of 300 to 500 pounds per square foot, and is so arranged in connection with the Central Railroad of New Jersey that cars can be run directly into the building to be unloaded. The walls are of concrete, with frames of steel. The floors are all heavy expanded metal, in the erection of which over 360,000 square feet have been used. It seems incredible that the thin layer of expanded metal could bear such enormous weights, but a very important fact about this expanded metal can be stated—it cannot be made of poor steel. If poor metal is put into

D. Saunders' Sons, Yonkers, N. Y., have long enjoyed an excellent reputation for the manufacture of high-class pipe threading and cutting machines. The catalogue for 1907 is larger than any of its predecessors, extending to 132 pages, and embraces full descriptions and illustrations of more than a hundred different machines and tools chiefly adapted for pipe threading and tapping and drilling, besides numerous forms of hand stocks, and dies for pipe taps, and reamers and vises and other tools. The long experience and marked success of the company have given them opportunities to become thoroughly acquainted with the needs of the trade, and it is but just to state that they have successfully met the growing requirements of the trade. A notable feature that has contributed in no small degree to the success of the company has been the admirable system of testing their output before placing it on the market. Their tools are reliable. All interested should send for a copy of their new catalogue, the publication of which, it may be stated, cancels their previous catalogues.

# One Year and Eleven Months' SERVICE

WITHOUT REPACKING, ON

## High-Pressure Locomotives

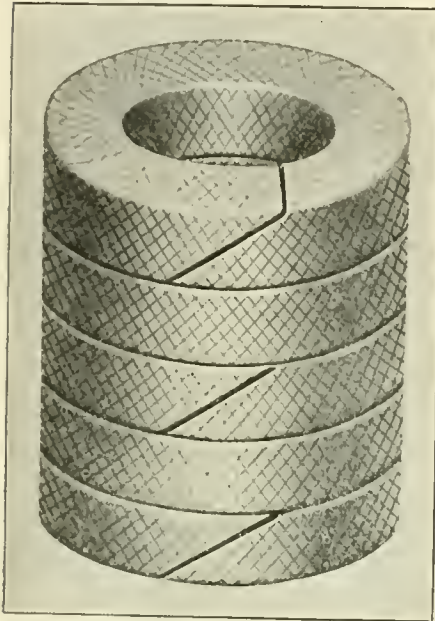

Style 300 TV.

A throttle failure is an absolute impossibility where Crandall's Throttle Valve packing is used.

IT WILL NOT BLOW OUT

## Crandall Packing Co.

FACTORY AND GENERAL OFFICE

PALMYRA, - - NEW YORK

BRANCHES

New York  
136 Liberty St.

Cleveland  
9 So. Water St.

Chicago  
32 West Washington St.

# Patents.

GEO. P. WHITTLESEY

McGILL BUILDING WASHINGTON, D. C.  
Terms Reasonable Pamphlet Sent

## Molding Machines

Vertical Vibration Power Draft  
ALL KINDS OF MACHINES

THE E. H. MUMFORD CO.  
17th & Callowhill Streets, PHILADELPHIA, PA.  
J. W. JACKMAN & CO., Ltd., 30 Victoria St.

The Lackawanna people use hard coal for their passenger engines and have remarkably clean trains. They have advertised this feature of the road through a fictitious young lady, Phoebe Snow, traveling on locomotives and cars in spotless white attire.

A joke that involved President Underwood of the Erie and President Truesdale of the Lackawanna was told recently at a New York banquet. These two presidents were going along Broadway one day when Mr. Truesdale stopped and talked a minute with what seemed to be a colored woman. Underwood began to joke his friend about stopping to talk with a negress and Truesdale replied that was not a colored woman, that was Phoebe Snow just come in from Chicago over the Erie.

The Catalogue on Springs got out by the Railway Steel Spring Company of New York is a standard size publication which is beautifully printed and illustrated. It shows various forms of locomotive driving springs with ends slotted for sword hangers, with bulb ends, and with jaw bands. Engine truck springs with curved and with flat bearings for strap hangers, tender springs, caboose springs, reverse lever springs, duplicate and triplicate elliptical springs; also the same kind made in the sectional form. Then comes passenger car springs, doublet, quadruple, and quintuple; quadruple with auxiliary bands, three-quarter elliptical springs, and single full elliptical springs. The catalogue also shows draw gear springs, double coil, freight bolster springs, equalizing springs, helical springs for locomotive trucks and for locomotive reversing gear and safety valve springs. All these are made in any variety to suit conditions. Write to the company for a copy of the catalogue if you are interested; their address is 71 Broadway, New York.

The Safety Car Heating and Lighting Company of New York have moved their offices to more commodious quarters. They are now on the seventh floor of United States Express Building, which is situated at Trinity Place and Rector street, just in rear of Trinity Church. This company handles the Pintsch lighting system for railway cars, and indeed all the many applications of this system to marine and stationary lighting.

The Baltimore & Ohio Railroad have recently placed an order for the installation of a Kennicott water softening plant. It will be situated at East Side, Philadelphia, Pa., and will be capable of treating 40,000 gallons of water per hour.



**SKAT!**  
Off Comes the Dirt.

When the hands are smeared and stained with a greasy grimy coat of oil, soot, dust and dirt, rub on a little

**SKAT**

TRADE MARK

**The Best Hand Soap Known**  
and see how quickly they're clean and soft again. SKAT is made to do what ordinary hard soaps can't do. Gets into the pores and loosens all the dirt so it simply rinses off. Pure, effectual and beneficial to the skin. 10 cents a can.  
Write postal for free sample and we will tell you where to buy SKAT, or if not sold in your locality, will tell you how you can become our exclusive agent and make money selling it. Write to-day.

**THE SKAT MANUFACTURING CO.,**  
807 Park Street, Hartford, Conn.

Not long ago the Pennsylvania expressed official appreciation of the act of a fireman, by which an accident was averted. A derailment in a tunnel on the line blocked both tracks and the fireman of the stalled engine went forward with a torch to stop an approaching train on parallel track. The men in the engine of the approaching train did not see the light or the fireman, and he thereupon threw the torch into the cab of the moving engine. This prompt action had the desired effect and the train was stopped, and what might have been a serious accident was prevented. This is one of those emergencies which arises occasionally in railroad service and the fireman who saved his fellow employees showed that he had a cool head and a very alert brain and the company did simple justice in acknowledging the fact. This fireman was H. Barteman, of Bell Alton, Md.

### CONTENTS.

*The Great Tunnel .....	145
Reminiscences of an Old Timer, by Shandy Maguire .....	148
Varnish .....	157
Editorials:	
Low Centre of Gravity.....	160
Safety is a Staple Article.....	160
Railway Service .....	161
Fallacy about Boiler Explosions.....	161
Black Signal Report.....	162
Judging and Knowing Speed.....	163
The Injector .....	163
Book Notices .....	163
Correspondence School .....	165
Questions Answered .....	167
*Honeymooning on the Lehigh.....	168
*Air Brake Department.....	169
*Electrical Department.....	171
What is a Watt? George S. Hodgins.....	171
*Coal Stored under Water.....	174
*Boiler Skimmer and Blow-off Valve.....	176
*Items of Personal Interest.....	178
*Adjusting Stephenson Valve Gear, by James Kennedy .....	178
Crucibles .....	180
*Electric Night at the New York Club.....	182
*Automobile Baggage Trucks.....	185
General Foremen's Association.....	186
*Steel Postal Car on the Erie.....	187
Seats for Machinists.....	188
Jersey Central Warehouse.....	189
Theory vs. Practice.....	182
Early Turbine Engine.....	181
*Tool Holder for Lathes.....	186
Locomotives:	
*Hock of Holland Express.....	159
*Heavy Vandalia Moguls.....	175
*Simple Engine for the P. S. & N.....	151

# Railway and Locomotive Engineering

Copyright by Angus Sinclair Co.—1907

A Practical Journal of Railway Motive Power and Rolling Stock

Vol. XX.

136 Liberty Street, New York, May, 1907

No. 5

## Suspension Bridges.

The suspension principle, as applied to bridges, like a great many other things with which we are tolerably familiar, is not new, but when it takes the form of a railway bridge and a carriage road bridge in the same structure, it is certainly entitled to be called a

bridge builders, John A. Roebling's Sons Company, of Trenton, N. J., to whom we are indebted for the photographure from which our engraving of the Niagara bridge was made.

Suspension bridges, as we have said, are not new, and several curious examples of this form of road bridge

smaller ropes, and covered with bamboo. One of these bridges had a span of 225 ft., and was sufficiently strong to permit loaded animals being driven over it.

The suspension bridge shown in our frontispiece this month is the road bridge spanning the Menai-trait, which



ROAD SUSPENSION BRIDGE OVER THE MENAI STRAIT IN WALES.

bold and daring piece of engineering. Such a bridge was opened for traffic over the Niagara River in 1855. It united the village, generally called in those days Suspension Bridge, N. Y., with the town of Clifton, in Upper Canada. The engineer, whose name is inseparably associated with this great work, was John A. Roebling, the founder of the well-known firm of

were once in existence on the ancient public highways of Peru. A bridge of this kind on one of the mountain roads in that country was made from materials which the workman's hand found ready for use on the ground. The cables were of twisted osiers, passed over wooden supports, and reaching from bank to bank. These primitive

is the narrow body of water separating the island of Anglesea from Wales. The roadway is 100 ft. above water level at high tide, and is 500 ft. between towers. The bridge floor is about 30 ft. wide. The "cables," from which the bridge structure hangs, are composed of a series of short links, which in reality make three sets of chains, all of which hang from two lofty towers.

The shore ends of the chains are securely anchored in the ground, and although there is a heavy pull along the chains, due to their own weight and that of the bridge, the stresses are so arranged as to act vertically on the towers. The expansion and contraction of the chains is compensated for on towers by means of movable bearings.

lar way, and having got the parabola, we can derive the catenary from it very easily. The flame of the headlight burns in the focus of the reflector, and if it was possible to cut the reflector down the centre, sawing through the glass and the wick, we would have a parabola very clearly defined. Now, suppose the reflector be held upright

long between the centres of the towers. The bridge was carried by four cables, each 10 ins. in diameter, and the solid wire section of each of these cables was 60.4 sq. ins. Each cable was made up of seven strands, each strand containing 520 wires, of the finest quality of iron, No. 9 gauge. There were thus 3,640 wires in each cable, and the ultimate strength of the four cables was 12,000 tons. The permanent weight supported by the cables was about 1,000 tons.

In connection with the manufacture of these cables, a foot-note appended by the editor of Mr. Roebling's memoir on the bridge, published by John Weal, London, 1856, says: "It is an important fact that iron of a suitable quality for wire is increased in strength or tensile power nearly threefold by being drawn into wire. Thus, a rod of iron capable of sustaining, say, 30 cwts., when drawn into wire of only one-third its sectional area, or, what is the same thing, into three times the length of the rod, will still sustain 30 cwts."

The deflection of the cables, or, as we would say, the sag of the upper cables, at medium temperature, was 54 ft., and that of the lower cables was 64 ft. The effect of heat and cold upon the cables caused their contraction and extension, and the calculated difference in level of the bridge floor corresponding to a change of 100 degrees in temperature was 2 ft. 3 ins. in the centre, and this was found to agree closely with the results of actual observation.



OLD-TIME SUSPENSION BRIDGE AT NIAGARA.

which carry the load and prevent any tendency to tilt the supports.

The curve which a cable or chain makes when hanging freely between two supports is called a catenary curve and the derivation of this word is readily understood from a glance at the graceful sweep and form of the linked bars in the Menai bridge, or that of the road bridge at Conway Castle. The word comes from the Latin *catena*, a chain, and this is the curve which a rope or cable or chain of uniform weight per unit of length assumes when suspended between two points of support and acted upon by gravity. This is the same kind of curve which is made by a telegraph wire hanging between poles by the side of a railway track, though the sag of the wire is necessarily not great.

The catenary is an interesting curve from a mathematician's point of view, and he would probably speak of it as one of the roulettes of the conic sections. This expression refers to the method by which the curve can be constructed, without hanging a rope or chain between two supporting towers, and letting it settle itself under the influence of gravity.

A glance at a locomotive headlight reflector may help to make this clear. The reflector, when cut along its axis, is found to be a parabola. This curve is a conic section, because it is always formed when a cone is cut in a particu-

lar way, and having got the parabola, we can derive the catenary from it very easily. The flame of the headlight burns in the focus of the reflector, and if it was possible to cut the reflector down the centre, sawing through the glass and the wick, we would have a parabola very clearly defined. Now, suppose the reflector be held upright

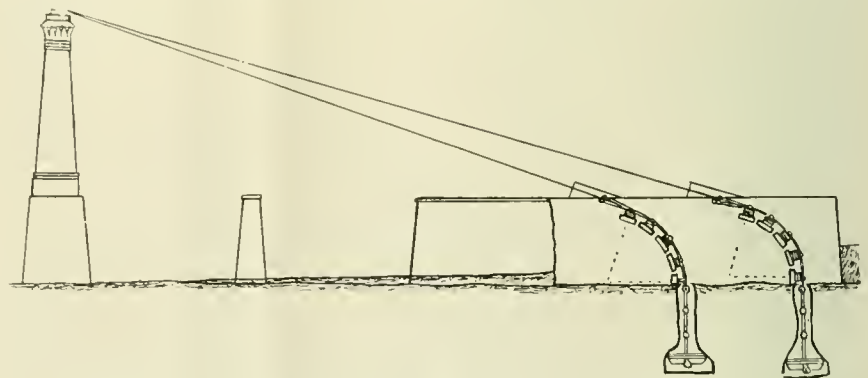

METHOD OF ANCHORING NIAGARA SUSPENSION BRIDGE CABLES.

(From Memoir of Niagara Falls Bridge, published by John Weale, London, 1856.)

to bring to light in the study of various curves. A catenary has a lower centre of gravity than any other curve hanging from the same points of support.

The railway suspension bridge over the Niagara gorge was, as we have said, opened for traffic in 1855. It has since been replaced by the steel arch, which we illustrated in our article on arched structures in the December, 1906, issue of RAILWAY AND LOCOMOTIVE ENGINEERING. The suspension bridge was used until 1897, a period of forty-two years. It was 821 ft. 4 ins.

The bridge structure itself was in the form of a hollow box, 24 ft. wide by 20 ft. deep, made with solid girders 5 ft. deep, trussed so as to effectively resist the action of any gale. In addition, there were 56 wire-rope stays intended to resist wind pressure. They were attached to the lower floor, and were securely anchored to the solid rock of the cliffs. Each of these ropes had an ultimate strength of 30 tons, or altogether 1,680 tons. This bridge, with its cables passing over the tops of the towers, which were 60 ft. 6 ins. high

and held to the cables by 624 suspenders, was used not only for railway trains, which moved along the top chord, at a height of 245 ft. above the

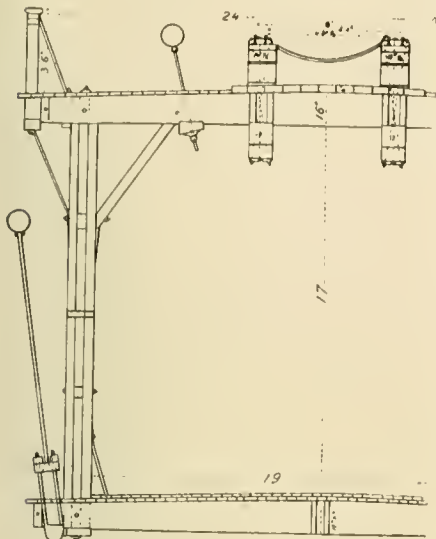

CROSS SECTION OF NIAGARA BRIDGE.  
(From Memoir published by John Weale.)

river, but its lower chord formed an ordinary roadway for vehicles, cattle, pedestrians, etc.

The injurious effects produced by the trotting of horses and cattle, or the marching of men, is thus spoken of by Mr. Roebling in the memoir already referred to. He says: "This is a subject which, next to the effect of high winds, is most important to be considered. The Niagara bridge is a great thoroughfare for all kinds of stock. Drovers of cattle are, according to regulations, to be divided off in troupes of twenty, no more than three such bodies, or sixty in all, to be allowed on the bridge at one time. Each troop is to be led by one person, who is to check their progress in case they should start off on a trot. \* \* \* I will state here, that in my opinion a heavy train, running at a speed of twenty miles an hour, does less injury to the structure than is caused by twenty heavy cattle under a full trot. Public processions, marching to the sound of music, or bodies of soldiers keeping regular step will produce a still more injurious effect. No bridge, constructed *without* regard to stability, will long resist such tests. The best built suspension bridge, as well as all kinds of wooden or iron structures, not excepting tubular bridges, will suffer from this cause. The Covington suspension bridge, opposite Cincinnati, with a single span of 550 ft., erected last year (1854), and since rebuilt, fell down under twenty cattle trotting over."

The anchorage of the cables of this bridge was formed by the sinking of eight shafts into the solid limestone rock, which forms the uppermost layer of the cliffs. Each shaft had a cross-

section of 3 x 7 ft., and was enlarged at the bottom so as to make a chamber 8 ft. square. Into each of these chambers a large anchor plate was laid. Each plate was of very strong, cold-blast, charcoal iron, made at the foundry of Oliver T. Macklem, of Chippewa. The plate was 6 ft. 6 ins. square, 2½ ins. thick and had eight heavy ribs on the lower side. The anchor chains were composed of nine links, all of which were 7 ft. long, except the top one, which measured 10 ft. The lower link was composed of seven bars and was secured to the cast-iron anchor plate by a pin 3½ ins. in diameter, ground to its seat. The next link was composed of six bars and two half-bars on the outside. The aggregate section of each was 69 sq. ins. After securing a plate and its chain in position, the whole shaft was filled with

sary to enclose the whole length of the chains in masonry. The temperature of the iron was thus kept comparatively uniform. The ends of the chains where they connected with the cables were also enclosed in masonry thoroughly grouted. The ultimate strength of the four chains was equal to 11,904 tons.

This notable bridge united the New York Central Railroad with what was then the Great Western Railway of Canada. This latter road has since become part of the Grand Trunk System, and the traveler to-day is carried over the magnificent steel arch, which now stands where once hung probably the most widely known international highway in the world.

If you wish to be miserable think about yourself, about what you want,



SUSPENSION BRIDGE AT CONWAY CASTLE, WALES, SHOWING EYE BAR SUSPENSION CHAINS.

(Stereograph, Copyright Underwood & Underwood, N. Y.)

masonry laid in cement mortar, and copiously grouted. Mr. Roebling tells us that the great and very sudden changes of temperature which are experienced about Niagara made it neces-

what you like, what respect people ought to pay you. In this way you can spoil everything, make misery out of everything, and be as wretched as you choose—Charles Kingsley.

### Billy's Thermometer.

The walls of the railroad repair shops were disfigured with brewery calendars extolling the virtues of buck beer, and Billy's thermometer relieved the degrading tedium of the tawdry posters that affronted the gazer's eye and gave a kind of scientific relief to the sodden surroundings.

When the midday whistle blew a wild stampede was made for Clark's parlors, and thin soup, hot as molten lead, and "schooners" of beer, big as Etruscan vases and cold as ice, were dished out to the hungry and thirsty mechanics. To mankind generally wine is a mocker, but in Billy's case Clark's best beer had the

pounds, and his philosophical mind was running on pure science. Would we care to see a demonstration? Certainly. Billy procured a piece of scrap iron and heated it in the firebox of a locomotive and laid it in one of the brazen bars that encircled the ball of the thermometer like the demarcation lines of the zones that mark a miniature terrestrial globe. The day was excessively hot and the great city was like a vast furnace. The mercurial column was already up in the nineties, but when Billy placed the piece of hot iron in the region of the torrid zone the mercury climbed to insufferable heights.

We ensconced ourselves in the engine cab and kept quiet and waited results. A

and what with the blazing furnaces inside and the blazing sun outside, Billy's thermometer would have shown to better advantage up there; but the reports had reached the distant gallery, and an asthmatic coppersmith, afflicted with what he called stomach trouble, which was nothing more nor less than chronic alcoholic gastritis, superinduced by thirty years' visitations to Clark's parlors, had suddenly been overcome by the reports circulated in regard to the manifestations of Billy's thermometer.

Two strong men brought the aged sufferer downstairs. He tottered feebly towards the superheated instrument and sank into a state of coma. The alarm became general. A sympathetic enthusiast rang up the nearest hospital. In an incredibly short space of time an ambulance came clanging into the shop yard and a young doctor fresh from Bellevue was in our midst. He felt the trembling pulse of the collapsed coppersmith and called for ice. It came in barrowfuls. Where was Billy and his medicine chest? Billy had the finer sense that stands back in the presence of his superiors. The young physician was doing the doctoring, and Billy looked gravely on. Billy was not altogether idle. When the clamor was at its height, and the panic-stricken crowd clustered around the wan-faced coppersmith, Billy slipped pieces of ice into the antarctic circles that guarded the polar extremities of the mercurial bulb, and the column shrank like a big schooner of beer in Clark's parlors when a thirsty blacksmith has a long pull at it.

When the coppersmith was carried away in the ambulance with the young doctor a comical dog of a brass finisher looked at the thermometer and declared loudly that he was going home to take in his geraniums, in case they would become frostbitten. A perceptible chill ran over the crowd, and we expected to hear the teeth of some of them rattling like dice on the deal tables in Clark's parlors on a pay night. They looked at Billy's thermometer and they looked at each other. The marks of fire or frost had been carefully removed by the clever hand of Billy, but the mercurial column lingered long enough in the wintry regions to cool off the crowd.

A fine sense of humor is not given to every one, and this high faculty is especially far removed from a shop superintendent. He had met a scattered delegation hastening to Clark's parlors. He looked at his watch, and it was twenty minutes past one and the men idling. His remarks are unprintable. He approached Billy's thermometer just as the marvelous change of climate showed its effects on the bewildered beholders. He ordered the immediate destruction of the instrument. His word was law. A blow from a sledgehammer wielded by a friend of the overheated coppersmith and delivered



WILLIAMSBURG SUSPENSION BRIDGE, NEW YORK.

effect of bringing out the intellectual side of his character. Under its influence his tongue became finely eloquent and strangely mercurial, and whether it was cool beer, or hot soup, or tobacco smoke, or pig's feet, or stuffed cheese, their united forces never made Billy too full for utterance. On the contrary, Billy became a fountain of gratuitous garrulosity. The burning questions of the hour passed in rapid review and became transfigured in Billy's mind like pieces of colored glass in a kaleidoscope. Sometimes his eloquent harangues were accompanied with demonstrations. He was great on phrenology. He took the sizes of men's heads, and occasionally lit the lamp of hope in the black brow of wasted energy. Billy had a medicine chest and microscopes and Jamaica ginger and court plaster. His thermometer was securely nailed to the wall, and in hot weather it became a center of interest outrivalling the blackboard where official notices were posted and where shop rules were placarded that nobody ever read.

Billy had just returned from his midday refreshment full of Clark's com-

big blacksmith's helper came along. His face was as red as a boiled lobster and great spherical liquid globules shone on his dark brow like beads of amber. He looked at Billy's thermometer and his jaw fell. He ran into the blacksmith's shop and returned with two companions. The three wise men laid their heads together, and one of them, finding speech, exclaimed: "Hully gee!" He was a poor man, with a big wife and small family, and he could ill afford to lose any time; but the limit of physical endurance had been reached, and he was going home, and home he went. Others clustered around, and the panic spread from shop to shop and ran from gallery to gallery. Billy's thermometer was correct. Everybody knew that. It was not an erratic instrument that ran up to high altitudes and then left itself sticking in detached segregations of mercurial molecules when a chill came. It was something to swear by. Another and another sweltering mechanic laid off his overalls and went home by way of Clark's parlors. Presently there was an uproar in the tinsmith's shop. It was always hot there. It was near the roof,

in the region of eternal winter broke up Billy's thermometer, and the bliss of ignorance fell upon the mystified mechanics like a benediction.

**Ten-Wheeler for Peru.**

The Rogers Works of the American Locomotive Company have recently completed an order of ten engines for the Southern and Central Railways of Peru. The locomotives, which are of the 10-wheel type, are intended for passenger service, and, as will be seen from our illustration, are of American design throughout. Those for the Central Railway of Peru, one of which is here shown, will operate on 3 and 4 per cent grades, this road ascending to an altitude of 15,600 ft. above the sea level at the highest point on the line.

In working order the engines have a total weight of 141,000 lbs., of which 104,000 lbs. is carried on the driving-wheels. The cylinders are 19 ins. in diameter by 26 ins. stroke, and are equipped with Richardson balanced slide

number, 2 ins. outside diameter and 12 ft. 9 ins. long. The total heating surface is 1,952 sq. ft., of which the tubes contribute 1,804 sq. ft. and the firebox the remainder. The firebox, which is equipped with oil-burning apparatus, is 102½ ins. long and 41¼ ins. wide. In the design of the boiler the top and side sheets are sloped toward the rear, parallel with the crown and sides of the firebox. The object of this arrangement is that the staybolts are at right angles to both the inside and outside sheets and a fuller thread is secured in the outside sheet. The engine is an oil burner and is equipped with the Von Roden-Ingleso, 3-in. oil burner. The grate is, of course, not used as in the burning of coal, and its area, which is 29¼ sq. ft., is not of much importance as far as the fuel oil is concerned, though the rocking grate has been provided so that coal may be burned if necessary.

The tender is of the ordinary U-shaped type and carries 2,000 gallons of oil, or 8 tons of coal if that kind of fuel is used.

Volume of cylinder = 81.2 cub. feet.  
 Total heating surface = 2.29  
 Volume of cylinders = 2.29  
 Grate area  
 Volume of cylinders = 3.44  
 Wheel base—Driving, 13 ft., 23 ft. 2 ins.; total, engine and tender, 47 ft. 5 ins.; weight in working order, 141,000 lbs.; weight in working order, engine and tender, 232,000 lbs.  
 Axles—Driving journals, 8½x11 ins.; engine truck journals, diameter, 5½ ins.; length, 12 ins.; tender truck journals, diameter, 4¼ ins.; length, 8 ins.  
 Fire Box—Type, narrow; length, 102½ ins.; width, 41¼ ins.; thickness of crown, ¾ in.; tube, ½ in.; sides, ¾ in.; back, ¾ in.; water space, front, 4 ins.; sides, 3½ ins.; back, 3½ ins.  
 Crown Staying—Radial.  
 Tubes—Length, 12 ft. 9 ins.; iron.  
 Brake—Reservoir, 1¼, ¾x144 ins.

**Industrial Peace.**

Some time ago Congress passed an act establishing the foundation for the promotion of industrial peace. This was done at the suggestion of President Roosevelt, who provided a fund for this purpose out of the money he received as the recipient of the Nobel Peace Prize. Four more trustees have just been added to those already appointed.

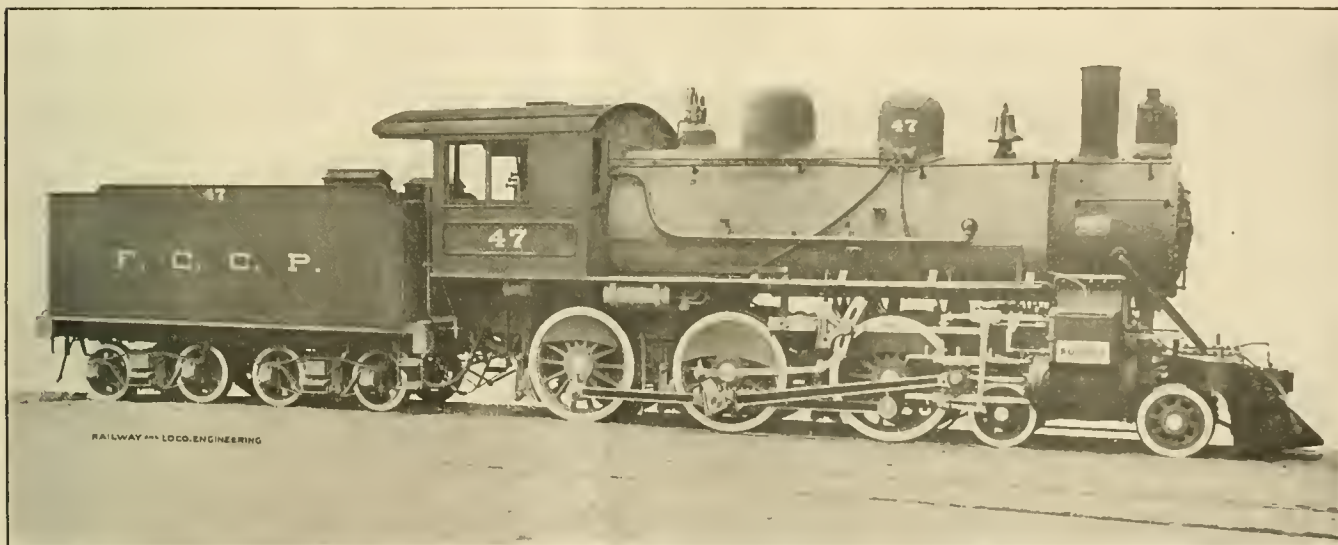

A. Pautrat, Master Mechanic.

TEN-WHEELER FOR CENTRAL RAILWAY OF PERU.

American Loco. Co., Builders.

valves actuated by the Walschaerts valve gear. With driving-wheels 58 ins. in diameter and with a boiler pressure of 200 lbs., the engines have a maximum tractive power of 27,500 lbs. The frames are of wrought iron with double front rails. The driving wheels are equally spaced and all are flanged. The cross-head is of the alligator type and both guide bars are undercut along the edge so that crosshead and bar are flush on the side. The lodgment of dirt and grit is thus avoided along the edge of the top bars. As the Walschaerts valve gear is used the lead is constant, being 3-16 of an inch, the steam lap is 1 in. and the exhaust edges of the valve are line and line with the ports. The valve travel is 5½ ins.

The boiler is one of the wagon-top type with an outside diameter at the front end of 63-16 ins. The tubes are 272 in

The water capacity of the tank is 4,000 gallons. The tender frames is made of 16 in. steel channels. The trucks are of the arch-bar type, with 33-in. wheels. Because of the steep grades on which these engines will operate, they are equipped with two 9½-in. Westinghouse air pumps, and with the Le Chatelier water brakes.

Some of the principal ratios of the design and general dimensions are as follows:

Weight on Drivers = 3.8  
 Tractive Power  
 Weight on Drivers = 0.74  
 Total weight  
 Weight on Drivers = 53.7  
 Total heating surface  
 Total weight = 72.3  
 Total heating surface  
 Total heating surface = 66.9  
 Grate area

The first members were the Chief Justice of the United States, the Secretary of Commerce and Labor, and the Secretary of Agriculture.

The newly appointed trustees are John Mitchell, president of the United Mine Workers of America; Marvin Hughitt, president of the Chicago and Northwestern Railway; Seth Low, of New York, and T. G. Bush, of Birmingham, Ala. The first of these represents industrial labor in the broad sense of the word and is an able man. The railroad president, who is one of the broadest-minded men in his class, is the representative of capital. The other two are public-spirited citizens of the highest reputation, who on this board represent the general public. The President is to be congratulated on his selection of representatives

# Patent Office Department

**HAND-CAR.**

Mr. J. H. Taylor, Normandy, Tenn., has patented an improved hand-car, No. 847,030. It embraces a combination with the driven axle and its pinion, of the drive-gear and its axle, a pivotally supported

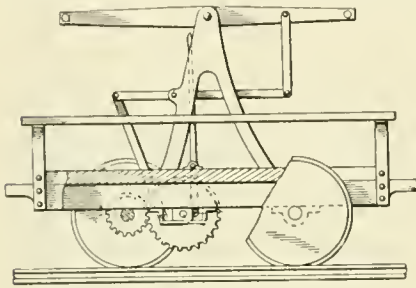

NEW DESIGN FOR HANDCAR.

bearing for the axle of the drive-gear, and a lever pivotally connected with the said bearing to move it on its pivot and disconnect or connect the driving gear from the pinion.

**WASHING BOILERS.**

Mr. W. White, Chicago, Ill., has patented several improvements in the system of washing and filling locomotive boilers. One of Mr. White's latest inventions, patent No. 847,387, comprises means for separating the steam and water taken from the boiler, means for heating other water by the steam, means for automatically regulating the amount of water so heated, means for storing such heated water with the boiler water, means for regulating the temperature of the water so stored, means for distributing this water for washing and filling boilers, and also means for regulating the temperature of the distributed water.

**TANK-CAR.**

A tank-car has been patented by Mr. T. R. Brown, New York. No. 846,646. The

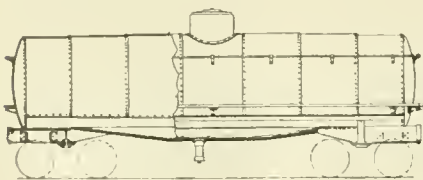

IMPROVED TANK CAR.

car is furnished with a tank sheet or plate having a longitudinally-disposed trough-like depression, and longitudinally-disposed reinforcing-flanges adding stiffness to the structure. The bottom sheet or plate forms a medium through which

buffing and pulling stresses are transmitted. The tank sheets forming the top and side walls of the tank are secured to the bottom plate, the whole forming a substantial and durable structure.

**VALVE-SETTING MACHINE.**

An apparatus for use in turning the driving wheels of locomotives in the process of valve setting has been patented by Messrs. J. J. Conolly and J. Heron, Marquette, Mich. No. 848,011. As shown in the accompanying illustration, the mechanism embraces a plurality of load-sustaining rollers, a fluid pressure cylinder connected with the rollers to operate the rollers, and means for controlling the exhaust from the cylinder to control the operation of the machine. There is a

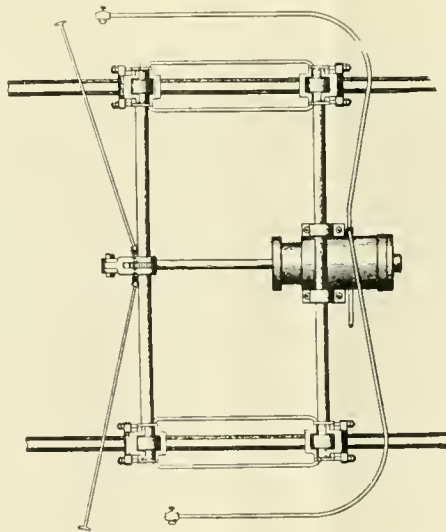

MACHINE FOR VALVE SETTING.

ratchet rigidly secured to the shaft, and means for reversing the direction of rotation of the rollers.

**DRAFT-REGULATOR.**

A draft-regulator for steam-boilers has been patented by Mr. A. J. Snow, Fromberg, Mont. No. 847,209. The device comprises a combination with an exhaust-pipe, an extension pipe movable into and out of alignment therewith, a latch pivotally mounted on the fire-box door with intermediate means whereby the extension pipe is moved into alignment with the exhaust pipe, and means for holding the latch in an elevated position while the fire-box door is open. The effect of the combination of mechanical devices is not only to regulate the draft, but it also has the double faculty of regulating the back draft when the furnace door is opened.

**BALANCING LOCOMOTIVE ENGINE.**

An ingenious method of balancing locomotive engines has been patented by Mr. H. F. Shaw, Boston, Mass. No. 848,572. The locomotive is furnished with a counter crank-shaft having four cranks arranged in pairs, one pair at each side of the center of the engine, the cranks of

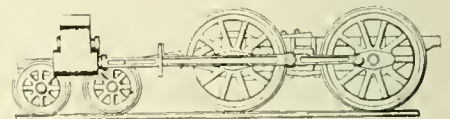

METHOD OF COUNTERBALANCING.

each pair being set in opposition to each other, one of each pair being connected to the center of a parallel rod and also to the main rod of a high-pressure steam-cylinder, while the other crank of the pair is connected to the main rod of the low-pressure steam-cylinder.

**VALVE FOR ENGINES.**

A steam-actuated valve for engines has been patented by Mr. D. C. Springer, Connellsville, Pa. No. 847,028. The device embraces a cylinder having inlet and exhaust ports with a piston working therein, a steam chest secured to the cylinder, a frame fitted within the steam chest, ports in the frame and ports in the walls of the steam chest, a plate fitted on top of the frame and having a central opening. The valve is fitted within the frame to reciprocate beneath the plate, and having inlet and exhaust ports, a second steam chest is secured to the first-mentioned steam chest, and ports for establishing communication between them, a

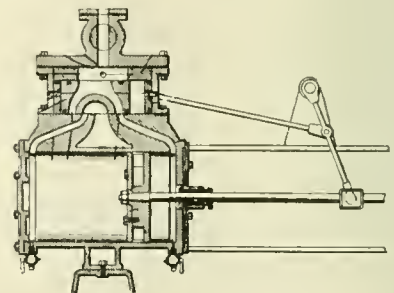

MAIN VALVE FOR ENGINES.

balanced valve in the second steam chest, a stem connected to the valve and connections between the stem and the piston rod whereby the valve is actuated. It will be understood that the motion of the valve is fixed, the amount of travel being in a ratio to the attachments of the cross-head lever.



PISTON ROD PACKING.

A piston rod packing has been patented by Mr. H. W. Lee, St. Louis, Mo. No. 844,525. The device comprises a series of overlapping conical

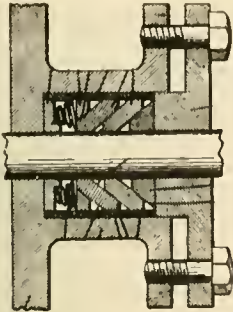

PISTON ROD PACKING.

packing rings arranged on the interior of a stuffing box, each of which packing rings comprises a series of segmental sections, each provided with a curved periphery and an inclined front face, as shown in the illustration. The outer ring is broadened to meet the surface of the piston gland.

SUPERHEATER.

Mr. F. A. Haughton, Schenectady, N. Y., has patented a steam generator and superheater, No. 847,407. The mechanism consists of a tubular boiler provided with a cylindrical chamber extending inward from one end of the boiler, the inner end of the chamber terminating in a tube head, the chamber being connected with the fire box by fire tubes extending from the fire box to the head of the chamber in combination with a superheater consisting of another chamber located within the aforesaid chamber and provided with fire tubes, which register with the fire tubes of the boiler, which enter the chamber.

Creosote Analysis.

The United States Department of Agriculture has recently issued trade bulletin No. 13 on the subject of the methods of creosote analysis, with reference to the preservation of wood treated with creosote. Among other things, it is stated that coal-tar creosote is generally regarded as the most efficient of the wood preservatives. This product is very variable in composition, owing to differences in the coals used and in the methods employed in their distillation. Creosotes of different compositions are believed to have different values as wood preservatives, and an analysis of the oil used is, therefore, important.

The most important part of creosote analysis is the fractional distillation, since by this operation an approximate determination is made of the relative proportions of the most important substances in tar oil. Laboratory experi-

ments carried on by the Forrest Service have shown that the difference in the weights of the fractions obtained when using different sorts of distilling vessels are not large, but that the composition of the fractions indicate a little better separation by the flask than by the retort. As regards the influence of the rate of distillation, variations of from one to three drops per second have but slight influence on the weights of the fractions, though the slower rate is more satisfactory.

It is commonly believed that the relative amounts of light oil, naphthalene and anthracene oil are the most important factors determining the value of creosote for wood preservation. A number of creosotes were very carefully fractionated and determinations made of the amounts of naphthalene and solid anthracene oil distilling be-

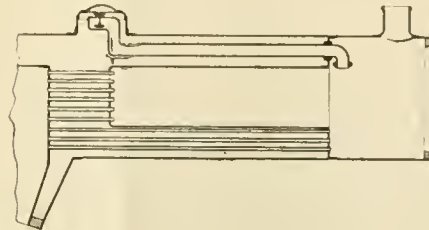

LOCOMOTIVE SUPERHEATER.

tween various temperatures. The average of the results shows that at least twenty-five per cent. of naphthalene was present in the distillate between 205° and 250° C., and that over twenty-five per cent. of anthracene oil solids are present in the distillate above 300° C.

The desirability of getting the criti-

The secretary, Mr. G. P. Conard, informs us that upon the urgent request of a considerable number of members of the Association of Transportation and Car Accounting officers, the Executive Committee have favorably considered the question of changing the date of the annual meeting so that this assembly will be held in St. Paul, Minn., Tuesday and Wednesday, June 25 and 26.

M. M and M. C. B. Conventions.

The annual convention of the American Railway Master Mechanics' Association will be held in Atlantic City, June 12, 13 and 14, 1907, and the annual convention of the Master Car Builders' Association will be held in the same place June 17, 18 and 19, 1907. The meetings will be held in the sun parlor of the Steel Pier. The offices of the railway supply men will also be upon the Steel Pier and the exhibits, except those of engines and cars, will be upon the Steel Pier. These conventions promise to be well attended and they form a pleasant break in the lives of many railroad and supply men.

South African 4-6-4.

Some time ago we received a photograph of a 4-6-4 tank engine from a friend of ours, Mr. Philip Hyde, in South Africa, who was until recently locomotive superintendent for the Central South African Railways.

The engine reproduced here is one of these engines and has cylinders 18 by 26 in., with 54-in. driving wheels. The boiler pressure is 200 lbs. per sq. in. and the tractive effort is 24,960 lbs. The weight of the whole machine in

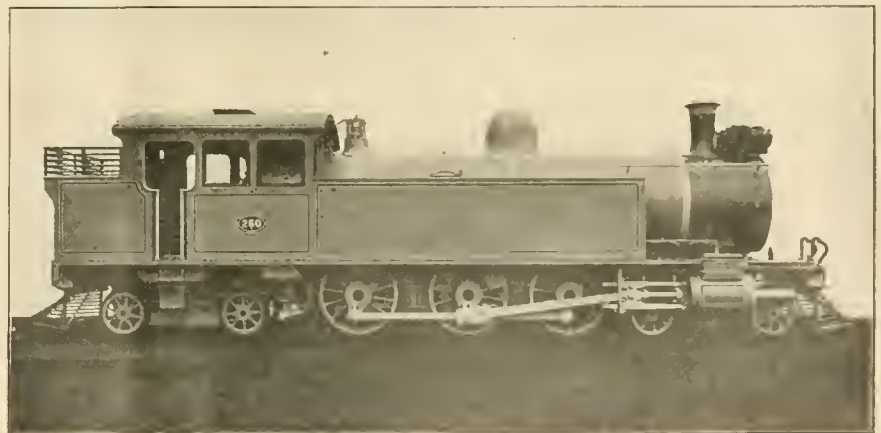

SOUTH AFRICAN 4-6-4 TANK ENGINE.

cisms and suggestions of users of creosotes has led to the publication of a detailed account of the methods employed in the experiments and the results which have been obtained. Those who desire the publication should ask for Circular 80, Fractional Distillation of Coal Tar Creosote. The request should be made to the Forester, Forest Service, Washington, D. C.

working order is 79 long tons. The heating surface in the boiler amounts to 11,481 sq. ft., of which 1,350 is in the tubes and 131 in the firebox. The grate area is 215.4 sq. ft. The tank has a capacity of 1,800 Imperial gallons and carries three tons of coal.

It was built by the Vulcan Foundry, Limited, at Newton-le-Willows, Lancashire, England.

**Steel Underframes for Wooden Cars.**

The general use of steel cars and the weight of trains hauled has made it almost imperative that all cars in service be of somewhat similar construction. The handling of light cars between those of greater weight and capacity has frequently resulted in damage to the weaker cars, and this damage almost invariably appears in the draw gear or draw timbers.

With a view of supplying a stronger underframe construction for wooden equipment and with the idea of eliminating to as far as possible the weaker cars, the Ralston Steel Car Company, of Columbus, Ohio, have designed a steel underframe for replacing the center sills of wooden underframe cars that has given

running repairs and only to a limited number of the first three hundred cars equipped with this underframe. At present the company are turning out twenty frames per day and preparations are now being made to double the output of the shop and it is expected by June a capacity of from forty to fifty frames per day will be reached.

These underframes are applied to a limited number of cars at the Ralston Steel Car Company's works, but the majority of the output is supplied direct to railroads for application in their own shops at the time heavy repairs are made to any of the equipment for which the underframe is designed, or to builders of wooden cars, the underframes being used

ing is also made by two other down expresses which daily run to this town without an intermediate stop.

Water is picked up from track troughs no less than three times by all these four trains, and the down Riviera limited de-

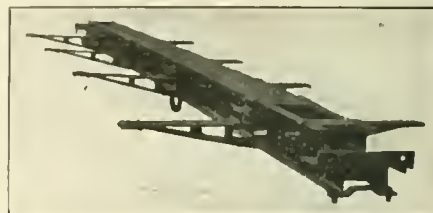

FIG. 2. CENTRAL BOX GIRDER.

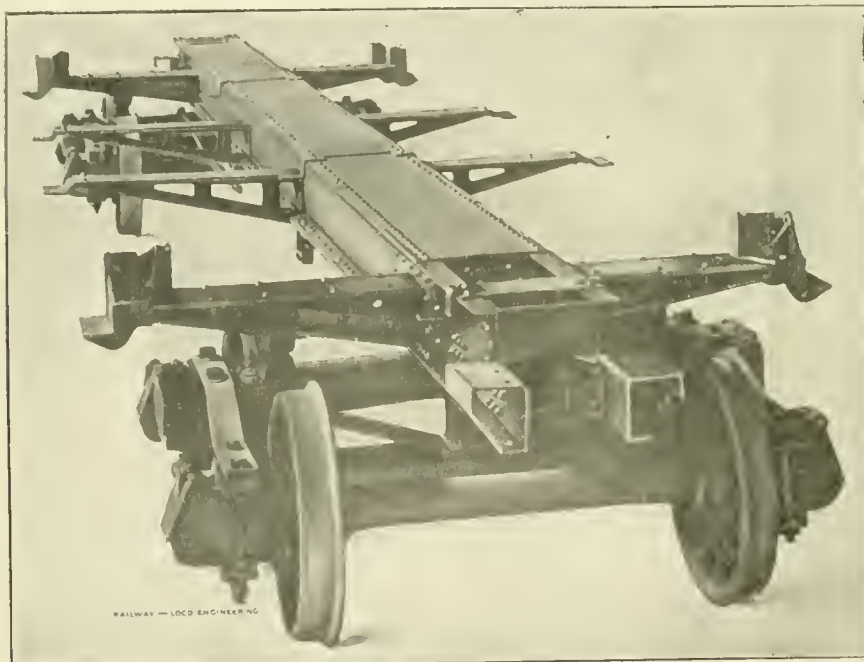

FIG. 1. BOX GIRDER CENTRE SILLS, WITH BODY BOLSTERS AND NEEDLE BEAMS.

very satisfactory results, and during the past year their shop has been and is now pushed to full capacity to supply the demand.

The underframe—as shown in our illustration, Fig. 1—consists of a box girder composed of channels and cover plates. The channels are notched and bent at the end to receive the end sill, and are slotted for the top needle-beam plate. The needle-beams are composed of a tension and compression plate member with a malleable iron filler, and the body bolsters are either of a construction similar to the needle beams as in the design for the Hocking Valley box cars, or they are of a patented type and inserted in the underframe built for the Kana-wha and Michigan gondolas, Fig. 2.

Cars with this underframe construction have been in service for eighteen months and have given the utmost satisfaction, no repairs whatever having been made during this time other than very minor

to replace the usual wooden construction.

**Where Long, Fast Runs are Made.**

The American joker abroad is always pretending nervousness while traveling on British railways for fear the train runs off the side or end of the small island, but nevertheless the railways on that tight little island lead the world for high speed on long runs. The Cornish Riviera limited expresses, which daily run in each direction between London and Plymouth, 225¾ miles, does so without an intermediate stop, in 4 hours 10 minutes.

When it is remembered that the last fifty-two miles of the run are over a winding switchback road, where grades of any steepness up to 1 in 40 abound, some idea will be formed of the difficult task set for the locomotives.

The average speed of these trains between London and Exeter, 173¾ miles, is 57.0 miles per hour, and the same tim-

taches three independent slip coaches, one after the other, during the journey.

Before the new direct line to the west of England via Westbury was opened, the runs made by these two world famous trains were more astonishing still, as the distance covered by them daily without stopping was 245¾ miles, twenty miles more than at present, while the average booked speed for 152 miles was 60.6 miles per hour, including a severe slack at Bath, and a worse one through Bristol, 4 minutes being consumed by 1½ miles of curved road through the latter town.

However, these limited expresses keep excellent time and have proved so remunerative that they have been continued through the winter months, the time to Plymouth having been cut to 4 hours 7 minutes with the down train, while the up limited now calls at Exeter.

An additional non-stop express has also been put on from Exeter, bringing the number of these 173¾ miles non-stop expresses on this one English railway to four, in addition to the down Riviera limited with its 225¾ miles run.

Timkins was coming home from his Easter holiday. Train crowded Timkins takes his little girl on his knee. Fashionable young lady comes up to carriage window to see if there is



RAILS SPREAD ON A CURVE.

room, upon which little Mabel exclaims: "Oh, papa, I'll stand and give the lady my seat. Passengers giggle. Timpkins blushes. Young lady does ditto, and rushes on.—*Tit-Bits.*

# General Correspondence

## Frame Repairs.

Editor:

I hand you a photograph showing a scheme we have adopted for repairing broken locomotive frames. Instead of taking the frame down and welding on a new front jaw to replace the broken part, we have a new front section of frame made of cast steel corresponding with the part plainly indicated on photo. This is substituted in its entirety to replace the old frame, which has been cut off at points marked "X," the new being bolted, and welded to the old friends, as indicated by the collars, by the agency of "thermit," the collars not being in any way objectionable at this location and the enlarged section affording additional security.

We have applied these cast steel sections in this manner to a number of frames and in every instance with entire success. We not only find considerable economy in the operation by avoiding costly forging, but gain in returning the locomotive to service, for with the finished cast steel section on hand for repairs it can be applied and the engine returned to service in less than twenty-four hours' time. We are extending this method to rebuilding some engines where reinforcing of frames has been found necessary.

W. McINTOSH,

Supt. Motive Power,

Jersey City

C. R. R. of N. J.

## Duty of a Doctor.

Editor:

In RAILWAY AND LOCOMOTIVE ENGINEERING for February, page 68, you ask for opinions on "Duty of a Doctor." The question involved is simply one of professional ethics as between physician and patient.

This patient should be firmly impressed with his moral responsibility and the great danger to which he is exposing the traveling public and be influenced to change or resign his position. The physician has no moral right to divulge anything told him professionally.

Your supposition that the patient is an engineer only minimizes the condition as he always has a fireman with him who could apply the air if anything happened to the engineer.

DR. JAMES A. COLEMAN,

Toledo, Ohio.

## Boiler Explosions.

Editor:

In the April number I have read your article, "Fallacy About Boiler Explosions." I am glad to see something of this nature in opposition to the erroneous statements and belief of many men, who as you say ought to know better, even if not familiar with the molecular construction of metal and its states of deterioration. Yet with all due respect to this class of men, there are others in positions of authority and responsibility who do not know any more, while some that do know more try to attach blame of a boiler explosion on low water; this invariably is so with nine cases out of ten.

misleading and confusing in a measure. While I have always claimed explosions were due to some part of the boiler being too weak to withstand the pressure to which it was subjected, occasionally we hear of a new boiler bursting. This I know of occurring recently. In this particular case it was low water, too, the crown sheet being  $\frac{1}{8}$  in. thick in some parts where it should have been  $\frac{3}{8}$  in. I still stuck to my statement, "some part of boiler being too weak for pressure;" yet majority said it was caused by low water, this being a new locomotive. What in these kind of cases is it that causes boiler to explode? I claim, as I have already said, but majority say if there was a weak-

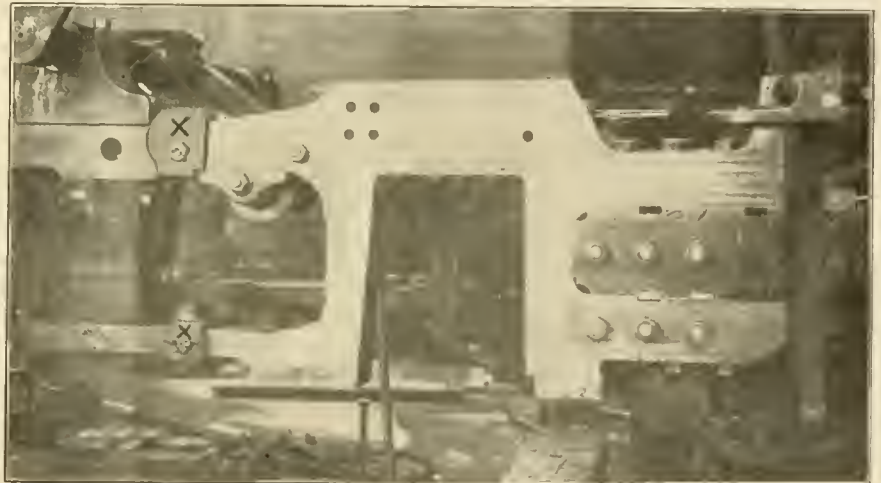

FRAME WELDED AT THE C. R. R. OF N. J. SHOPS

Of course, in some cases it is done to avoid personal sacrifices.

Now, if a boiler explosion takes place nine men out of ten will either ask or say, "Low water," but when asked what they mean they really don't know in some cases, while in others they will give the reason as you have published, simply sheets being hot and water coming onto the same. Some will suggest the idea that it generates a high pressure enough to fracture the boiler, hence the explosion. Now in regard to the explosion parts, your article seems about as good as anything I ever read. The idea I have always had and maintained conforms right to your article. Yet why is it that an engineer is in most cases blamed for a boiler explosion by the cause, "Low Water," this being assigned by his superiors, and those of the class who ought to know better in the positions they are filling or trying to fill.

Yet, on the other hand, this subject is

ness it was caused by too high a steam pressure, this resulting as they say from cold water being forced onto the crown sheet. I cannot see it.

Wherein I can see is in the case where a crown sheet has been hot and had crown bolts calked, rew fusible plug and fired up and run with same pressure. It seems to me as if the molecular construction of the sheet would be destroyed in a case like this and engine would hardly be safe. Am I correct in this view? I wish you would please inform me in your next edition, and if consistent with your practice also state how and what are the principal causes of so many explosions. Of course, anyone can see how too great a pressure will cause a fracture, yet many will claim that this pressure is created by cold water coming in contact with hot plates. I can not see it.

HARRY W. TILLEY,

West Springfield, Mass.

### Portable Crank Pin Machine.

Editor:

Inasmuch as the outside end of a locomotive crank pin, from which projects the gudgeon screw, never becomes altered in shape, it follows that if a machine of a suitable character be attached to the

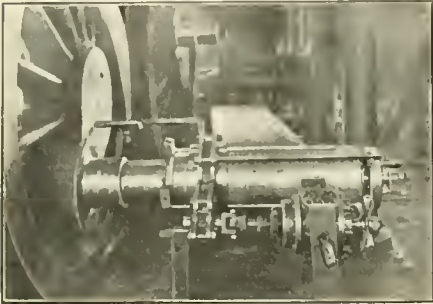

CRANK PIN MACHINE IN USE.

screw, and facing truly against the end just referred to, the surface of the crank pin, which through use has become altered in form, can easily be restored to its original shape and quarter.

The accompanying photograph shows such a machine attached to the pin and ready for operation. The manner in which this machine performs the work is as follows: After screwing the machine firmly to the end of the crank pin by means of the two handles, the latter are removed and the sliding sleeve is placed on the barrel. Attached to this sleeve are four lugs, containing the necessary tools for roughing, finishing and filleting the crank pin. The tools are of  $\frac{5}{8}$ -in. round high-speed steel. The gear wheel and casing are then slipped over the two feather keys, when by means of an air motor the sleeve is caused to revolve around the crank pin.

The forward or feeding motion of the sleeve is accomplished through mechanism contained in a hand wheel, which feeding is either automatic in character or the result of hand labor, according as the gearing is engaged or disengaged. It is not necessary to stop the motor to perform this last action. Provision has been made for any lost motion accruing from ordinary wear and tear of the barrel and sleeve, by adjustable rings, which are screwed against taper split bushings on each end.

The machine consists of four parts, no one of which is too heavy to be handled by even a boy. This crank pin turner can be adjusted to any pin having a threaded end by simply making a face plate to suit the pin, and threading it to fit the extension. The largest locomotive crank pin can be restored to its original shape in three hours, a great saving of time being thus effected as compared with the practice generally in vogue of removing or filing the pin.

The machine can be used in any round-

house without removing the wheels from the engine, and is successfully operated with 70 lbs. air pressure through a "Little Giant" air motor. As a result of several years' observation, it has been ascertained that providing the main pins are maintained in a "true" condition, those in the front and rear wheels require little or no attention. The number of rod breakages will be materially lessened, and the brasses will give a far greater mileage. Several of these machines are in use by the Grand Trunk Railway Company, having displaced various other makes. The device has been patented.

M. H. WESTBROOK.

G.T.R. Shops, Port Huron, Ont.

### Safety Hanger for Equalizer.

Editor:

The blue-print which I send you is of the driving wheels of one side of an eight-wheel locomotive and shows two safety hangers attached to the main frame, one at each end of the equalizer, which are designed to catch the equalizer

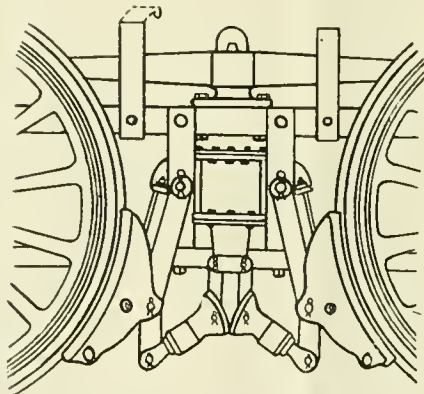

SAFETY HANGER FOR EQUALIZER.

and hold one spring in place in case of accident to the other.

Several locomotives on the Clinton Line which run from Kansas City to Humansville, Mo., are equipped thus, and the engineers are very enthusiastic in their praise of the appliance. On several occasions they have been able to continue their runs without delay after a breakdown. I was very much interested in this device, and perhaps other readers of RAILWAY AND LOCOMOTIVE ENGINEERING may be interested. I therefore have sent you the print to illustrate the device.

Chicago, Ill.

D. H. G.

### Early Steamboats and Dr. Lardner.

Editor:

When a gentleman undertakes to give what might be termed practical scientific information to a meeting of students he is in duty bound to be certain of his facts. The railroad saying, "Be sure you are right then go ahead," applies very urgently to the case of a person setting himself up as a mentor to the initiated.

This impression has come to me

through reading, in the April number of RAILWAY AND LOCOMOTIVE ENGINEERING, some remarks attributed to Mr. W. E. Symons, who is made to say: "He spoke of the well known case of Dr. Lardner, a noted scientist and engineer, who had in the early days of the steamboat done much to retard steamboat construction, and practically delayed it for nearly a score of years."

In one of the Cantor Lectures on "Transmission of Energy," Professor Osborne Reynolds says: "Science teaches us the results that will follow from a known condition of things, but there is always the unknown condition, the future effect of which no science can predict. You must have heard of the statement in 1837 that a steam voyage across the Atlantic was a physical impossibility, which was said to have been made by Dr. Lardner. What Dr. Lardner really stated, according to his own showing, was that such a voyage exceeded the then present limits of steam power. In this he was within the mark; so any one would be if he were to say now that conversation between England and America exceeded the limit of the power of the telephone."

When the real facts are presented it will be seen that Dr. Lardner was not a conservative obstructionist, but a scientist ready to discuss intelligently the facilities and forces then at the command of the world.

In regard to Dr. Lardner's statement having done much to retard steamboat construction for twenty years there is certainly a conflict of opinion. Two steamers crossed the Atlantic the year after Dr. Lardner's famous comments were made. These two voyages inaugurated a transoceanic steam service that has never been uninterrupted, but has grown steadily in extent and importance. The Cunard Steamboat Line was established in 1840. The first steamer of that line, the *Britannia*, sailed from Liverpool for New York July 4 of that year and

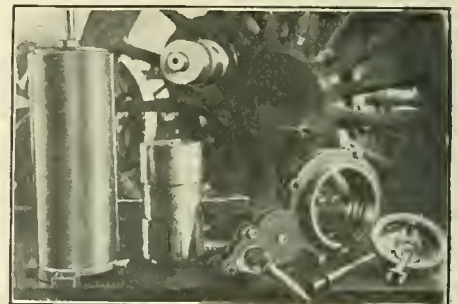

PARTS OF THE CRANK PIN MACHINE.

the vessels of the company have continued making regular trips ever since. There does not seem to be any evidence that the enterprise was dampened in the smallest degree by Dr. Lardner's remarks.

It does not seem good to me that such misrepresentation of facts as Mr. Symons

indulged in before young people who desire knowledge and who are in the sprouting stage should be allowed to pass. These young people should not be told things that later they will learn belong to the realms of romance.

Passaic, N. J.

READER.

**Swiss Locomotives.**

Editor:

Some time before the purchase of the Jura-Simplon by the Swiss confederation, this company (the Chemins de fer Fédéraux) put two locomotives of the type 701-702 into express service on the different lines of our network of railways, and particularly on the Simplon line (Geneve-Lausanne-Brigue).

The locomotives were intended to meet the following conditions. On the first trial the speed obtained was 74½ miles per hour without working the engines hard. Fifty of these locomotives were distributed among the districts, at Lausanne, Bâle, Zurich and St. Gall. These engines are the handsomest and most graceful locomotives on our continent.

They are of the de Glehn type, 4-cylinder compounds. The two high-pressure cylinders are outside and their pistons drive on the third pair of coupled wheels. The two low-pressure cylinders are inside and the pistons drive on the first coupled pair of driving wheels with a crank axle made in one piece. These cylinders are immediately below the smoke box. The high pressure valve gear is the Hensinger and the Joy gear is used for the low pressure.

The cylinders are 14.15 and 22.4 ins. by 26-in. stroke. The driving wheels are 70 ins. in diameter. Bogie wheels 33 ins.

working order is 230,000 lbs. The tender wheels are 40½ ins. in diameter. The capacity of the tender is 4,500 U. S. gallons of water and 11,000 lbs. of coal. The tender wheel base is 183 ins., and the total wheel base of engine and tender is 734 ins. The adhesive weight of the engine, 101,000 lbs. The tractive effort of the engine is 15,900 lbs.

The engines of the series 2,701-2,750 are intended to haul freight trains of from 1,380,000 to 1,540,000 lbs. on a grade

has a large dome in which is placed the throttle valve from which the operating rod is carried to the cab along the outside of the boiler.

The boiler has 242 tubes and a brick arch is used in the fire-box. The high-pressure cylinders are 14.6 by 23.6 ins. The low-pressure cylinders are 23.6 by 25.3 ins. The driving wheels are 52½ ins. in diameter and the engine truck wheels are 33½ ins. The driving wheel base is 128 ins. and the total wheel base



DE GLEHN 4-6-0 SWISS PASSENGER COMPOUND.

of 10 per cent. and also heavy passenger trains 440,000 lbs., running 15.6 miles per hour up a grade of 26 per cent. These locomotives are capable of traveling from any of the stations on the line to Domodossola-Iselle, where the grade is 26 per cent.

In order to obtain the greatest possible adhesion the engine is carried on four coupled axles and one radial axle. This axle is placed in front in order to insure

is 295 ins. The fire-box heating surface is 155 sq. ft., the total being 1,900 sq ft. The grate surface is 26½ sq. ft. The steam pressure is 200 lbs. The light weight of the machine is 132,000 lbs., and in working order it weighs 146,000 lbs. The tender weighs light 38,000 lbs. loaded 87,000 lbs., making a total of engine and tender in working order of 233,000 lbs. The tender wheels are 40½ ins. in diameter, with a wheel base of 183 ins. The tank capacity is 4,500 U. S. gallons of water and 11,000 lbs. of coal. The total wheel base of engine and tender is 720 ins. The tractive effort of the engine is 20,200 lbs. Westinghouse automatic and straight air brakes are used. These engines burn only 35.2 lbs. of coal per mile in hauling a train of full tonnage.

WILLIAM BONNETT, M. E.

Zurich, Switzerland.



2-8-0 SWISS FREIGHT ENGINE.

The driving wheel base is 164 ins., and the total wheel base is 330 ins. The heating surface is 1,800 sq. ft. in all, of which the fire-box has 167 sq. ft. The grate surface 28 sq. ft. The steam pressure is 214 lbs. The light weight of the engine is 129,000 lbs., and in working order it is 142,000 lbs. The tender light is 37,600 lbs., and in working order it amounts to 88,000 lbs. The engine and tender in

even curving. The two high-pressure cylinders are inside and the pistons drive on the second coupled axle. The low-pressure cylinders are outside and the pistons drive on the third coupled axle. The high-pressure cylinders have piston valves actuated by Walschaert's gearing and the low-pressure cylinders have ordinary slide valves. The cranks on the same side are placed at an angle of 180 degs. The boiler

**Passing Stop Signals.**

Editor:

I have read with much interest the recent discussion in your publication relative to engineers. I have no desire to cast any unmerited disparagement on the members of the profession, but several occurrences of the past year have furnished some little food for thought.

There recently appeared in some publication, which came to my notice, a statement in connection with the enforcement of rules relating to block signals on a Western road, to the effect that several engineers, one of 36 years' standing, were discharged for

persistently running past red block signals; another stated that, on another road, some 12 or 15 trains, passenger as well as freight, ran past a certain signal set purposely at danger; only one local freight stopping to investigate. Several minor accidents have occurred in New England within the past year on protected sections of track, and I have, personally, witnessed numerous cases where engineers have run past red blocks without any attempt to reduce the high speed at which they were running.

I have wondered how many more accidents would have occurred if the other necessary factors had been present: the engineer who runs past the red signal has done his part toward producing the wreck. I have not the least doubt but that some, perhaps many, cases are with the knowledge of the officials, but I have yet to be convinced that there are a goodly portion which are not "up to" the engineer.

FRED L. EASTMAN.

Wollaston, Mass

**Slow Transportation in Old Days.**

Editor:

Taking out locomotives just after the close of the Civil War was subject to many delays that are unheard of to-day. I had one enjoyable (?) trip, as follows:

A locomotive was to go from Providence, R. I., to Clayton, Del., in December, 1866. It was shipped on the nineteenth via New Haven, Port Morris and by boat to Elizabethport, arriving there the twenty-fourth, in the evening. Was taken off the boat at 8 o'clock A. M. on the twenty-fifth, and taken to Elizabeth at about 10 o'clock A. M., ready to be taken to Phillipsburg, N. J.

Left Elizabeth at 5 P. M. on stock train, arriving at Phillipsburg at 10 P. M. At 9 A. M., the twenty-sixth, it was taken to South Easton, where it remained until 5 P. M., when it was taken on fast freight to Allentown, Pa., getting there at 7 P. M., when it was transferred to the East Penn Railroad, ready to start for Reading, Pa. The start was made at 5:30 A. M., the twenty-seventh, and reached there (Reading) at 10 P. M. After being turned over to the Philadelphia and Reading it was put on through freight for Belmont, leaving at 5:30, getting to Belmont (now part of Philadelphia) at 12:30 that night (or next morning).

At 10 A. M., the twenty-eighth, was taken to Gray's Ferry to remain there until 5 P. M., when the Philadelphia, Wilmington and Baltimore Railroad took it on to Wilmington, Del., arriving there at 8 P. M., where it remained

until morning, at 5:30, when the Delaware Railroad started it for Clayton, getting there at about 9 o'clock A. M. There it was left for the Maryland and Delaware Railroad Company to take possession, as it was for that road, and they got it to Greenburg, Md., at 4 P. M., where it was to be set up and put to work.

This was the twenty-ninth of the month, taking only eleven days and nights to get from Providence, R. I., to Greenboro, Md., which is about three hundred and seventy miles. The engine was set up on a sidetrack out in an open field, the large smokestack for wood burning, was put in place by hand, there being no apparatus for lifting it. After the engine was put together it was fired up and moved around on the thirty-first of December, and at 8 o'clock it started from Greenboro with an excursion train from Clayton, Del., and returned in the afternoon. The water to fill the tank was



M. M.'S STAFF AT SHERIDAN.

taken from the ditch beside the road with a steam siphon.

HOSTLER.

New York, N. Y.

**The M. M. and His Entourage.**

Editor:

I am sending you a picture for publication in one of your numbers. It is a picture of the office force in the Master Mechanic's office at Sheridan, Wyoming, on the Sheridan Division of the Chicago, Burlington & Quincy, Lines West. The gentleman with the skull cap shown in the picture is your agent here. He is known as "Baldy" on the road. He would be very much pleased to have this appear in an early issue of RAILWAY AND LOCOMOTIVE ENGINEERING.

I have received the March number and am having great success in getting names. In this picture of Master Mechanic's office staff, Mr. F. E. Kennedy, the M. M., may be seen on the left hand side, standing with his back against the wall.

Sheridan, Wyoming. W. V. NEWLIN.

You may choose to play your part well or badly, but you do not choose your part. That choice is made for you by the author of the play.—*Epictetus*.

**British Notes and News.**

By A. F. SINCLAIR.

**THE CHANNEL TUNNEL.**

In the session of Parliament which began last February there was brought under discussion a bill for the construction of a tunnel between England and France. The proposal was that two tunnels 30 miles in length and 18 ft. diameter should be constructed alongside one another, leaving England in the vicinity of Dover and emerging close to Calais. With modern tunnelling apparatus there is nothing impossible about the proposal from an engineering point of view, but there are political and other obstacles to be surmounted. That the tunnel will come ultimately appears beyond question, and there are not wanting signs that the necessity for it may impress the guardians of commercial interests with sufficient force before long to secure for the project some chance of success.

**BRITISH LOCOMOTIVE ENGINEERING.**

Locomotive engineering in the United Kingdom was in a fairly prosperous state during the year 1906, but the success was the result of certain fortuitous circumstances of which it would be unwise to expect a repetition. The home demand has shown no sign of great improvement, the railway companies continuing to build their own engines and plant generally. British railways give comparatively little assistance to British companies engaged in locomotive building. South America and India were the customers whose requirements provided most of the work to keep the men busy, the home market coming third and a long way behind the other, too. These three markets must also be depended on to provide most of the work in the immediate future. There are, however, some signs appearing that other countries which at one time sent much work to British locomotive engineers, such as South Africa, Australia and Canada, may ere long send some further orders in the same direction.

**STRUCTURAL TENDENCIES.**

To say that the tendency of locomotives was to grow in size would be merely to state an obvious fact which is evident not only in railway engines, but in almost every form of machine engaged in purposes of transportation. During the last year, however, the increase has been so great that although the number of engines turned out is very likely no more than in preceding years, there has been a very distinct increase in work. To meet the increased size of engine the British makers have laid down enlarged plant, and there is no engine now constructed which the big firms could not cope with. British builders have held on tenaciously to their faith in copper, but there is a possi-

bility of their requiring to abjure it ere long. With prices away up to £110 (say \$550) per ton it is very questionable whether the sale of engines into which copper enters to any extent can be readily effected. Brass also has been used rather extensively about British-built locomotive purposes, and although one of its constituents, spelter, is about the only metal not involved in the present boom, the enhanced value of copper is bound to affect the price of brass to a prejudicial extent so far as use in locomotive building is concerned.

#### ACCIDENTS ON BRITISH RAILWAYS.

The year 1906 had a most unfortunate record so far as railway accidents of great gravity were concerned. Early in the year an accident at Salisbury to a special train connected with a trans-Atlantic steamer resulted in the death of a large number of American tourists. Later on an express ran through Grantham, where it should have stopped, left the rails, and a number of deaths resulted. Then just at the end of the year, when it looked as if Scotland were to have a clean record for 1906, at Arbroath, in the midst of a severe snowstorm, a fast train ran into the rear of a slow local, both carrying passengers, and between twenty and thirty people were killed.

#### Engine Failures.

The interesting subject of "Engine Failures and Their Report" was taken up by Mr. W. E. Dunham, M. M. on the C. & N. W. Railway, at a recent meeting of the Western Railway Club. Among other things, he said shortage of power at times may compel the use of engines on the road which under ordinary circumstances would be held back for shop repairs. These engines should not be expected to handle full tonnage. On the other hand, no engine should be allowed to start out unless it can, as far as known by the roundhouse foreman, make the trip if properly handled.

It is during a rush period that engine failures increase, often in proportion to the total miles run in a given period. An engine failure, when charged, should be fair and just. The fact that an engine has died on the main line, or has given up its train, is not in itself a cause for recording an engine failure. Very often a credit mark should be given instead of a demerit. It sometimes happens that an engine has been worked back and forth between outlying stations, and the dispatcher wants it to make one more trip before sending it in, as requested. In the endeavor to help the dispatcher, the crew attempt the task, and something happens. Is that properly an engine failure, or is it a man failure?

The failure report should be accurate as to facts. These reports usually originate in the dispatcher's office, and are made up at the last moment, when every one is in a rush, and from notes on the train sheets. As a consequence any occurrence which has annoyed the dispatcher is charged as an engine failure if there is half a chance. The result is that the officers of the road are bothered with useless letters concerning things which should have been investigated on the spot. This kind of thing creates bitter feeling and enmity. The failure report should be definite as to details. It should say flues leaking, or staybolts leaking, or mudring leaking, as the case may be. It should not be simply "not steaming" when flues are stopped up, poor coal, green

has been kept on sidings (other than by defects of engine for an unreasonable length of time, say fifteen hours or more per hundred miles). Reasonable delays in cleaning ash pans on the road. Engines coming from outside points to the shop for repairs. Broken draw gear on engine or tender caused by air set on train from burst hose or breaking in two. Delays to fast trains when weather conditions are such that it is impossible to make time with good steaming engine. Passenger engines or scheduled freights are delayed from other causes, and an engine having a defect makes up more time than she loses on her own account. Passenger trains which are less than five minutes late at terminals or junction points. Schedule freights when they are less than



LINE CLEAR ON MODERN BLOCK-SIGNALLED ROAD.

firemen, or leaky steam pipe is the real cause.

What constitutes an engine failure? First, all delays waiting for an engine at an initial terminal, except in cases where an engine must be turned and does not arrive in time to be cared for and dispatched before leaving time. Second, all delays on account of engines breaking down, running hot, not steaming well, or having to reduce tonnage on account of defective engine making a delay at a terminal, a meeting point, a junction connection, or delaying other traffic.

Among the things not considered engine failures are engines that lose time but make it up without delay to connections or other traffic. Engines given excess tonnage and stalls on a hill when working all right. Engines with leaky flues or poor steaming where engine

twenty minutes late at terminals or junction points. Dead freight trains, if the run is made in less hours than the miles divided by ten. Engines held at roundhouses for needed repairs and called for by the operating department, and they being informed that the engine will not be ready before a stated time. Engines out of coal or water held between coal and water stations an unreasonable time.

The proper kind of report not only informs the mechanical department of the failure and its cause, but shows up poor design, weak parts, inferior material, bad shop practices, careless handling, indifferent inspection, and poor workmanship. In order to fully indicate these defects, the foreman sends to the master mechanic his personal examination report and a marked sketch of the defective part. After the master

mechanic and assistant superintendent of motive power are done with the report it is sent to the mechanical engineer, who checks the dimensions of broken parts and makes use of the data in designing new parts for old engines or preparing plans for new ones. As a further record, and for the purpose of comparison, a monthly statement is prepared in the office of the superintendent of motive power and machinery, which classifies and details the failures and also shows totals for each division of the railway.

#### Rail Motor Engine.

The London & Southwestern Railway have recently built some interesting engines of the smaller type for what is called the motor car traffic. This is practically the passenger traffic for which one or two-car trains are used, one of the cars being generally equipped with a motor. The little engine shown in our illustrations is one of a class which is the outcome of the growing use of single cars for short journey work on railways in which they perform a somewhat similar service to that of street cars.

Sometimes when separate from the cars such locomotives are not available for any other purpose. This is not the case with the small engine shown. This little engine has been built by the London & Southwestern Railway Co. to the designs of M. D. Drummond, chief mechanical engineer, to whom we are indebted for photographs and other data.

In practice there is on each motor a driver and a fireman. When the engine is in front of the vehicles both men are on the foot plate, but when the engine is at the rear the driver is on the front

ranged on a wheel base of 8 ft. The cylinders are 10 ins. bore and 14 ins. stroke, placed outside and it will also be seen that the Walschaert form of valve gear is used. The boiler has a heating surface of 571 square feet, of which the

are only two men in the crew, the driver and the conductor. In such cases the driver stays on the foot plate and attends to the working of the engine, and the conductor, who is duly certified to do so, opens or closes the regulator when travel-

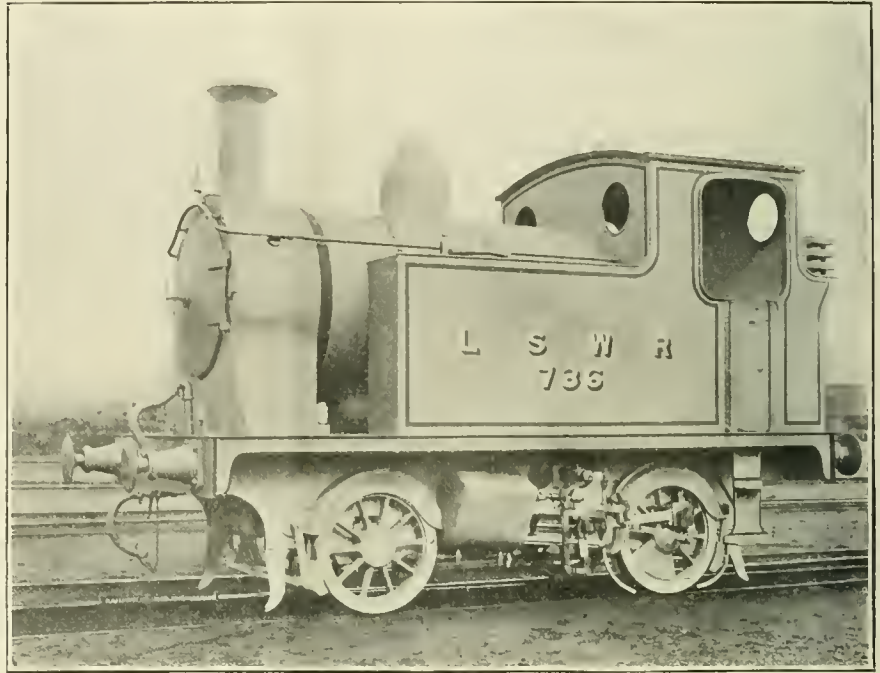

TANK LOCOMOTIVE FOR RAILWAY MOTOR TRAFFIC.

ordinary tubes provide 379 sq. ft., the firebox 73 sq. ft. and a number of water tubes in the firebox 119 sq. ft. The grate area is  $9\frac{1}{2}$  sq. ft., and the steam pressure is 150 lbs. per sq. in. The engine measures 19 ft. 7 ins. over the buffers and the total weight with 500 imperial gallons of water and one ton of coal is about 24 tons.

ing car first. The lookout man, therefore, is able to shut off and apply brakes. When running engine first the driver attends to these duties.

#### Water.

It is a singular circumstance that the popular estimate of the purity of water is very far from correct. Water from

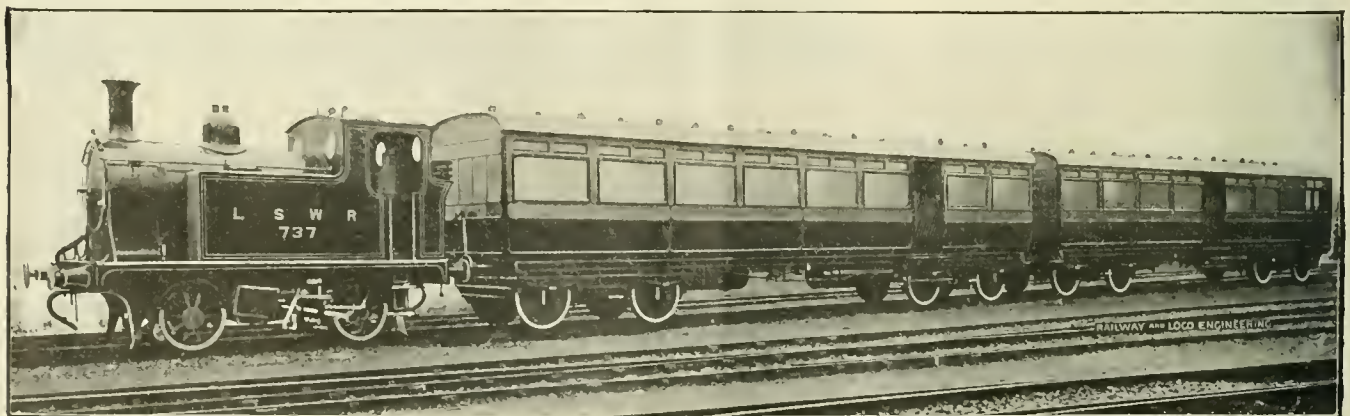

RAIL MOTOR ENGINE AND SUBURBAN TRAIN, LONDON AND SOUTHWESTERN.

vehicle and controls the regulator on the engine by mechanical means. The fireman is then on the footplate attending to the water in the boiler and the steaming of the engine and the reversing. Communication from one end of the train to the other is had by means of an electric bell.

The boiler is 48 ins. outside diameter. The wheels are 3 ft. in diameter, ar-

The engine may be called a single driver engine, as only one pair of wheels is used for propulsion. The tractive effort is 3,889 lbs. In one of our illustrations a pair of pulley wheels may be noticed on a pair of brackets on top of the cab. These are for the appliance for opening and closing the throttle. On some of the branches where traffic is light there

wells of considerable depth, on account of its coolness, seems to take the popular taste. The environment and locality of wells are so various that it would be impossible to classify the impurities that invariably accompany well water. It is safe to state that there are more impurities in this kind of water than that of surface drainage or water flow-



ing in rivers. It is usual, in projecting branches of new railways which pass through districts where there may not be a large supply of water, to dig wells for the supply of locomotives. The effect on the boilers is invariably pernicious. It may be stated broadly that rain water is the best for boilers. The

compartment seating forty passengers and a smoking compartment which will comfortably hold sixteen. There is a baggage and express compartment in the forward end, and the boiler and engines are located in the front, immediately over the driving truck.

The fuel is crude oil, carried in a

as they could guarantee delivery in 1908, which they evidently considered fast work for these times when every concern in the business is full of orders.

**Mogul for the Sun Ning Railroad.**

Our illustration represents one of two mogul locomotives recently built by the

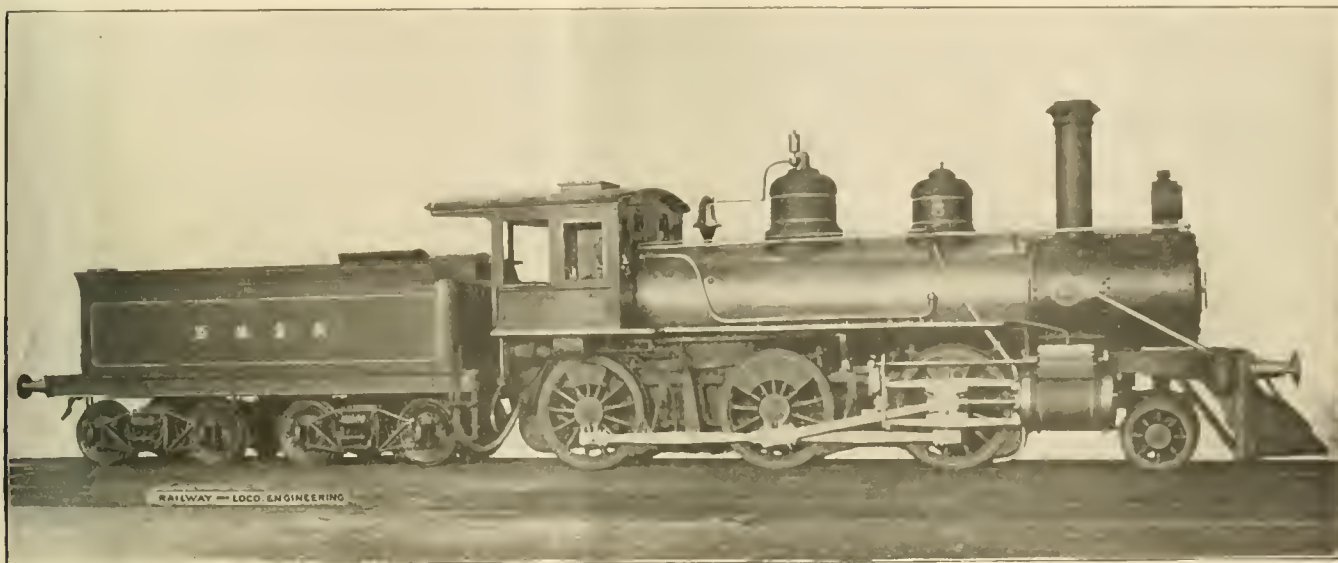

BALDWIN MOGUL FOR THE SUN NING RAILROAD IN CHINA.

slight scaling that occurs in the use of such water is not necessarily detrimental, and can be removed by an efficient method of washing out.

River water has the disadvantage of collecting impurities according to the districts through which it may have passed. Nearly all rivers contain much

steel tank under the car. The engines are sufficiently powerful not only to propel the car itself, but a trailer can be used when required. The car was built under the supervision of Mr. H. H. Vaughan, assistant to the vice-president of the road. A number of similar cars will be constructed at the Angus shops

Baldwin Locomotive Works for the Sun Ning Railroad of China. These engines are designed for standard gauge track and are typically American in most of their details. They represent a style of engine which for many years has done excellent work in freight service.

Among the foreign specialties with which these locomotives are equipped may be mentioned the screw couplings and spring buffers, which are applied to both the locomotive and tender. The Chinese characters on the tank are a conspicuous feature of the external appearance of the engine. The principal dimensions are as follows:

- Gauge, 4 ft. 8 1/2 ins.
- Cylinder, 15x24 ins.
- Valve, balanced.
- Boiler—Type, straight; material, steel; diameter, 48 ins.; thickness or sheets, 1/2 in.; working pressure, 180 lbs.; fuel, coal and wood; staying, radial.
- Fire Box—Material, steel; length 60 7/16 ins.; width, 34 3/8 ins.; depth front, 62 1/2 ins.; depth back, 61 ins.; thickness of sheets, sides, 5/16 in.; back, 5/16 in.; crown, 3/8 in.; tube, 1/2 in.
- Water Space—Front, 4 ins.; sides, 3 ins.; back, 3 ins.
- Tubes—Material, iron; wire gauge, No. 12; number, 150; diameter, 2 ins.; length, 10 ft. 8 3/4 ins.
- Heating Surface—Fire box, 100 sq. ft.; tubes, 836 sq. ft.; total, 936 sq. ft.; grate area, 14 sq. ft.
- Driving Wheels—Diameter, outside, 54 ins.; journals, 6 1/2 x 8 ins.
- Engine Truck Wheels—Diameter, 30 ins.; journals, 4 1/2 x 7 1/2 ins.
- Wheel Base—Driving, 14 ft. 2 ins.; total engine, 21 ft. 6 ins.; total engine and tender, 43 ft. 4 1/2 ins.
- Weight—On driving wheels, 68,620 lbs.; on truck, 14,100 lbs.; total engine, 82,720 lbs.; total engine and tender, about 133,000 lbs.
- Tender—Wheels, diameter, 33 ins.; journals, 3 3/4 x 7 ins.; tank capacity, 2,500 gals.; fuel capacity, 4 tons; service, freight.



STEAM MOTOR COACH ON THE CANADIAN PACIFIC.

organic matter which is suspended in a state a partial solution and takes solid form in the incrustation of boilers, but it is not so difficult to remove as the rock-ribbed scale that gathers from the use of water from wells.

**Suburban Steam Motor Car.**

Not long ago the Canadian Pacific Railway got out a design of a steam suburban motor car. It has a first-class

of the company for use in the suburban service between various points in the different localities along the line of the railway.

A very good index of the general prosperity not only here but all over the world, was recently shown by the fact that the Canadian Pacific Railway lately received an offer from a prominent English locomotive building firm, saying that they were now in a position to take orders

# Railway and Locomotive Engineering

A Practical Journal of Railway Motive Power and Rolling Stock.

Published Monthly by

**ANGUS SINCLAIR CO.**

136 Liberty Street, New York.

Telephone, 984 Cortlandt.

Cable Address, "Loceng." N. Y.

Glasgow, "Loccauto."

**Business Department:**

ANGUS SINCLAIR, President

JAMES KENNEDY, Vice-President.

JAMES R. PATERSON, Sec'y and Treas.

**Editorial Department:**

ANGUS SINCLAIR, Editor.

GEO. S. HODGINS,

JAMES KENNEDY,

J. P. KELLY,

CLARENCE RENSHAW,

} Associate Editors.

**Advertising Department:**

Eastern Representative, S. I. CARPENTER, 170

Summer St., Boston, Mass.

**British Representative:**

THE LOCOMOTIVE PUBLISHING CO., Ltd.,

Amen Corner, Paternoster Row, London, E. C.

**Glasgow Representative:**

A. F. SINCLAIR, 15 Manor Road, Bellahouston,

Glasgow.

**SUBSCRIPTION PRICE.**

\$2.00 per year, \$1.00 for six months, postage paid in the United States, Canada and Mexico. For other parts of the world, \$2.50, or ten shillings. Single copies, 20 cents. Remit by Express Money Order, Draft, Post Office Order or Registered Letter.

Mailing address can be changed as often as necessary—always give old and new address, and if you subscribe in a club, state who got it up. Please give prompt notice when your paper fails to reach you properly.

Entered at the Post Office, New York, as Second-class mail matter.

Copyright by Angus Sinclair Co., 1907.

For Sale by Newsdealers Everywhere.

## Fondness for Old Material.

An expensive practice that has prevailed in railroad repair shops ever since such places went into operation has been the efforts made to keep at work worn-out rolling stock and tools that have long passed their days of usefulness. When times are hard worn-out machinery is clung to because it is felt that the company cannot stand the expense of renewals; when business is good, machinery rises in price, and that is considered a proper excuse for making as few purchases as possible.

This propensity, while wise in its origin, is frequently carried beyond prudent limits, and then it becomes a source of waste. Having the capability of perceiving the point when it no longer pays to repair machinery is a somewhat rare attribute, but there is no form of ability that pays better to railroad companies or machine shop owners. There is a class of machine men who can never consent to send an intact article to the scrap heap till years of repose—in some places this stuff becomes obstructive litter—demonstrating beyond peradventure that it could never be used again. Engine 190 gets a new set of

axle boxes, but two of the old ones are in pretty good condition, and they are laid away carefully under a vise bench to be handy for any other engine of the same class that may come in with a broken box. A discarded eccentric strap taken off 187, and not more than  $\frac{1}{4}$  in. out of round, is laid to repose in the vicinity of the axle boxes, and the adjacent space is filled with discarded feed pipes; and infirm injectors and their fittings, old stack cones, nozzle tips, an odd rod strap, several half-worn piston-rings, a cylinder head with a short crack in it, a few brake-heads, a sand-box cover, and the inevitable oil-box cellar, besides a mass of miscellaneous litter, all too good to throw away.

A shop run under the influence of this kind of saving sentiment is usually a museum of worn-out articles, every recess and corner being filled with material that long ago ought to have passed through the rejuvenating power of the cupola or the forge. Good money has been paid out for pig and bar-iron, whose places ought to have been taken by the scrap stowed away under the pretence of being available stock. Stuff of this kind is never available when wanted, and its individuality is only seen at the annual resurrection caused by stocktaking. A predilection for preserving half-worn articles whose pattern has been changed is infinitely worse. In this case casting houses and store rooms are littered with articles that have not been used and will not be. A vague hope is entertained that rough castings and forgings of this character may come in handy for some purpose, but successive annual stocktakings pass, and they all remain on hand, apparent plenty at times, in the presence of real scarcity. Cylinder patterns that have not been used in a dozen years, oil-boxes which this generation has not seen in use, valves whose design only old men are familiar with, hundreds of details whose purpose the old pattern makers scarcely remember, are still preserved because the patterns have not rotted out. And all this time the pattern house is so overcrowded that searching for a pattern not in regular use entails hours of diligent labor.

This predilection for preventing the scrap heap from receiving its honest due is not confined to small parts of machinery. After many years it has finally been decided to get a new planer in place of the old one that has toiled in decrepitude long after truth and usefulness had departed from its operations. The new planer was placed where the old one had stood for a time beyond the memory of the oldest inhabitant. But was the ancient planer broken up? Not much. It was moved to the

corner of the shop for the purpose of being used on odd jobs, and it is continually in the way, and the work done on it needs so much hand finishing that the jobs cost double what they are worth. The 12-in. lathe that became too shaky for turning was transformed into a bolt cutter, in which capacity it does not illustrate thrifty management since the conversion cost half what a bolt cutter could have been bought for, and the tool will never do half the work a good bolt cutter would turn out.

Mistakes made in respect to the persistent clinging to absolute and unsuitable tools are scarcely so serious in their consequences as holding on to locomotives that have become unsuitable for the service of the road. Worn-out engines are hard to sell to advantage, and many railroads cannot afford to cut up good locomotives because they have become too light for the work; but, on the other hand, no expensive repairs should be devoted to engines that have outlived their usefulness. Send them to the second-hand agent is sound advice.

When engines that have become too light for any but special service on a railroad require new boilers and cylinders it is sound business to scrap them unless they can be sold to dealers, who often have mysterious ways of disposing of worn-out machinery. The companies that follow the practice of scrapping or selling machinery that has outworn its day of usefulness are the most prosperous. The fact should not be overlooked that, however thoroughly a car or locomotive may be overhauled and "made as good as new," and whatever amount of money may be devoted to putting it in that condition, it is still old, and its market value is regulated by its age.

## Low Water Boiler Explosions.

Last month we referred to a very prevalent fallacy to the effect that if the crown sheet of a locomotive boiler became overheated that it is dangerous to flood it with cold water. This idea has been found to be incorrect, as we pointed out, by experiments made with hot crown sheets and cold water, by the Manchester Steamers' Association and by tests made in this country, of which Dr. Coleman Sellars was a witness.

If the sudden cooling of the hot plate is not in itself sufficient to cause an explosion, it may be asked what does cause an explosion when the water has become low and the sheet exposed to the action of the fire and so overheated? The crown sheet of a locomotive is practically a flat surface held up against the steam-pressure by crown stays screwed into the sheet and riveted over.

When the sheet becomes dry, the steam-pressure does not diminish. The sheet

becomes hotter and hotter and consequently softer and softer, and eventually it begins to bag down between the staybolts in a series of rounded pockets. This condition may be likened to the appearance of a fully stuffed sofa seat or mattress which bulges up between each of the regularly spaced buttons, which have been put there by the upholsterers to keep the filling in place. In the case of the crown sheet the riveted heads of the stays also become hot and soft and the gradually bagging sheet pulls away from the stays.

The action of pulling away from the stays is such that the threads are sometimes not stripped. The staybolt holes in the sheet enlarge as the metal pulls down to form the pockets, and the pancake heads of the riveted stays are folded back and a portion of the crown sheet sags down. The sagged portion of the sheet is now unsupported, and though steam may blow down through the staybolt holes, yet the pressure of the steam is not relieved fast enough and the hot, soft plate not being able to withstand the high internal pressure, generally tears across a row of rivet holes and gives way altogether.

Up to this point there has been no explosion. It is the giving way of the sheet which causes the explosion and not the explosion which causes the sheet to fail. The cause of the explosion is the sudden liberation of the stored up energy in the water. Water at 200 lbs. gauge pressure has a temperature of 388° Fahr., which is 176° higher than that at which it boils at atmospheric pressure. Strange as it may seem, the sudden opening of the boiler reduces the pressure on top of the water and the stored up heat causes the water to flash into steam so rapidly and in such quantity as to cause what we call an explosion.

The liberation of stored heat is the reason that in blowing off an engine through the whistle, the water level goes down. The same forces are at work in each case and as a pound of steam blows away, the stored up heat turns another pound of water to steam until the water remaining in the boiler has a temperature of 212° Fahr. In blowing off the engine the process is slow and gradual. In the case of the ruptured sheet the liberation of pressure is sudden and the evaporation of the water by the stored up heat is sufficiently rapid to become violently destructive. It has been calculated that in an ordinary locomotive boiler with 200 lbs. steam pressure there is enough stored up energy to lift the engine more than two miles high if it could be applied to that purpose without loss.

The overheating of the crown sheet when it has become dry is not an instantaneous effect. It is rather a comparatively slow process. The dry crown sheet takes some time to become red hot, and the bagging

down between the stays is gradual. In many instances there has been evidence from the discoloration of the side sheets that where a boiler has exploded from low water, the continued evaporation in the boiler has exposed two or three rows of flues before the crown sheet became hot enough and soft enough to pull off the stays and tear apart.

Some boiler designers use one row of ordinary riveted stays while the next row has button heads, and so on across the crown sheet. The object of such an arrangement is if possible to allow the ordinary riveted stays to pull off first, put out the fire and gradually relieve the pressure before the sheet becomes hot enough to tear apart. Whether or not this would actually take place would depend upon circumstances. At all times the knowledge of the actual water level in the boiler is a matter not only of supreme importance to those on the engine, but it is generally a matter of life and death, for nowhere is the rule more absolute than it is on an engine, "eternal vigilance is the price of safety."

#### Railroad Legislation.

It is a singular condition of affairs that now presents itself in regard to the trans-continental railways in America. A long period of prosperity has taxed their capacity to the utmost, and it might be naturally supposed that with their vast earnings their credit would be unlimited. Such is not the case, however, and the chief railroads are now passing through a series of discouragements requiring much fortitude to face. Government activity, which was begun for the purpose of regulating traffic and of keeping business within legitimate lines, has been taken up by the more or less irresponsible press and by demagogues of high and low degree until an impression has been created that the railroads have been managed by thieves, and that railroad rates have been shamefully excessive.

The State Legislatures, often eager to influence popular clamor, have, in some instances, arbitrarily reduced rates, and this work has been done by men who had no more idea of what the effect of their work would be than a pack of school children would have in regulating the burning of a barrel of gunpowder. The result of such unfortunate meddling is of the most disastrous kind. The feeling of uncertainty thus created has the effect of not only reducing the value of the railway properties but also closes the money markets against them, so that the constantly growing need for betterments and repairs have to be postponed and

enterprises of great pith and moment are turned aside.

The question naturally arises as to why extensive money loans are needed. Two causes lead to this. The increase in the weight of locomotives and other railroad rolling stock has had the effect of producing heavy wear and tear on the roads, and many of them are badly in need of substantial repair. Heavy rolling stock engaged in heavy traffic has also caused a great increase in the expenses in the upkeep of the rolling stock itself. The roads are being beaten out of form and need rebuilding. This is particularly the case with the roads in the mountainous districts where there are practically no level roads.

It is annoying to railway managers that in this prosperous period, and at this time when the rebuilding of railways has almost become a necessity, that the newspapers and a certain class of politicians have succeeded in making it impossible for them to obtain the needed money to improve and extend their facilities. It is to be hoped that the good sense of the American people will manifest itself in calling a halt on this spirit of meddling. Too much legislation is one of the characteristics of all forms of free government, but it is not necessary for us to be carried away with it.

#### Electrically-Driven Lathes.

The rapid introduction of the electrically-driven lathe is one of the most prominent features of modern machine shop operation. The advantages are so obvious that they hardly need recapitulation. In addition to the speed being directly under the control of the operator, there is a marked economy of power, as it is only when the lathe is in operation that the power is used at all. The absence of intermediate shafting also eliminates an important loss of power. If we consider, also, the absence of the care of belting and shafting, and incidental repairs, it will be seen that the saving is very great.

Many of the new lathes seem to have been made with a similarity of design, the motor mounted on an overhead bracket, directly above the head stock, the variations being in the connection between the motor and the driven pulley, some being connected by a short, wide belt, fitted with a cone pulley of two steps, two sets of gears being provided, giving a total of six speed changes, with such intermediate changes as may be effected by the varying of multiple voltage systems, the number of which depends on the number of points of the controller.

Another popular form of connection

is that whereby the motor is geared directly to the spindle by intermediate gearing, avoiding the use of belting altogether. The use of rawhide gearing between the motor shaft pinion and the lathe gearing greatly lessens the noise in running.

We have observed a very compact lathe coming into use with the motor under the bed of the lathe, and close to the head cabinet. The motor has the advantage of being out of the way in the case of swinging axles or other lengthy work into position. The gearing is also almost entirely concealed, and this form of lathe ought to become popular, as it is extremely neat and free from the top-heavy appearance common to the motor-mounted lathe. It may be noted that many of the older, substantial class of lathes are being furnished with electric motors in many of the larger shops, and it looks as if the electrically-driven lathe will soon relegate the old countershaft-driven machine to comparative obscurity.

#### Lifting Appliances.

One of the first things that strikes a foreigner visiting American railroad machine shops is the multitude of apparently trifling operations of lifting to which power is applied for the purpose of saving manual labor. The comparatively high price of labor throughout the United States has led to the substitution of machinery in almost every conceivable position where it would dispense with the effort through human hands. No sooner does a workman find himself settled on a job where articles have to be raised to a tool or lifted to some distance from the floor than he begins scheming on the invention of a lift that will raise the articles by compressed air or similar means. The invention of the air brake has been indirectly the means of lifting many burdens away from workmen's arms.

In handling shop weights and in elevating grain and such material our facilities are unequalled; but when we require to move articles that run into the tons weight, it seems natural to fall back upon crude backwoods methods. There are as good cranes made in American workshops as are produced anywhere, but the demand for them is ridiculously limited even in establishments that are daily losing money by their tedious methods of moving heavy material. The ordinary American railroad station and freight house compare very unfavorably with those in Europe in regard to conveniences for handling heavy freight. On the other side of the Atlantic nearly every roadside station has a crane that will raise two or three

tons weight, and it is regarded as a necessity at every station where freight is unloaded. When a car comes in loaded with a heavy casting, a boiler or piece of machinery, it is switched to the crane and the heavy article lifted off without delay. At an American station, on the other hand, a crane is rarely found, and heavy weights are transferred from car to wagon by the manipulation of wedges, levers and rollers, supplemented by liberal expenditure of physical force. Those whose fathers wrestled with house raising and log moving without tools delight to display the ingenuity and progress of their ancestors.

These primitive operations of handling heavy articles cause continual delay to cars and frequent damage. The work of a whole yard is frequently suspended while heavy weights are being moved off a car; and the service of cars is often lost for days, waiting for a time to unload the material when the operation will cause the least inconvenience to the yard. Railroad companies and their patrons will all derive substantial benefit from the change when the day comes that a good crane will be provided at every station where heavy freight has to be unloaded.

#### Setting a New Sector.

When it becomes necessary to replace the quadrant or sector on a locomotive it must not be imagined that an exact reproduction of the worn-out quadrant with new teeth would suffice. Organic changes are taking place in the locomotive all the time. Distances from point to point vary, partly by the deterioration of the wearing parts, and partly by the haphazard method in which running repairs are often done. A new quadrant will necessarily involve at least a new latch in the reverse lever and also other new attachments. The valve gearing may be adjusted with the reverse lever in temporary positions, the lever being held steadily in place by a set screw at the desired points. The length of the reach-rod should be such that when the link block is in the center of the link the reverse lever should be standing perpendicularly on the quadrant. It may be remarked that the locomotive should be placed on the dead center while finding the center of the reverse lever, as that is the only point at which the link hangs in an exactly vertical position. This central point in the quadrant is of importance and should be reached by experiment on both sides of the locomotive.

Some constructors make an allowance for the amount which the link drops in service, because, as will be readily perceived, lost motion accumulates by the wear of the bearings, the link gravitating lower on the link block as the wear increases. It is also to be observed that the

expansion of the boiler when heated is much greater than the expansion of the reach-rod, and on locomotives where the quadrant is attached to the boiler this varying expansion has the effect of shortening the reach-rod and raising or lowering the link according to the position in which the links are placed in relation to the lifting shaft and reversing lever.

The reach-rod being of the required length, and the center of the quadrant being fixed, the extreme points of the arc through which the lever travels are to be noted, and it must be observed that the clearance at each end of the link is sufficient to preclude the possibility of the ends of the link colliding with the link block. The vibration of the parts of the link motion incident to railroad service is much more than is generally supposed, and three-eighths at the bottom of the link and one-half inch at the top should at least be allowed for clearance.

Having the three points marked on the quadrant, the distances can then be measured and the number of notches decided on by an approximate calculation of the thickness of the latch and the intervening spaces between the notches. The bridges between the notches should measure at least one-sixteenth of an inch more than the space required for the latch. The surplus distance, if any, after dividing the notches equally, can be added to the bridge spaces. It will be found that the space from the center to the front and back extreme points of the quadrant may differ in length, causing a difference in calculating the number of notches.

Some quadrants are marked off with a smaller number of notches back of the center than in front, but there is no great reason why they could not be laid off with an almost equal degree of regularity. It is well that the center be distinctly marked in some way, either by having the center notch separated by a larger intervening space from the others than the remainder or otherwise, and it may also be observed that it is necessary that the quadrant and the entire mechanism of which it forms the guiding part should be carefully re-examined after the finished quadrant has been hardened and polished and bolted into place.

#### Book Notices.

Modern Steam Engineering, by G. D. Hiscox, M. E. Published by the N. W. Henley Publishing Co., 1907, New York. 488 pages with 495 engravings and diagrams. Cloth, price \$3.00.

This book has been specially prepared by a well-known authority on the steam engine for the use of modern steam engineers, firemen and all who have to maintain power plants of any kind. It is a thoroughly complete and practical work. It illustrates the various types of engines and describes the properties and use of steam. The work is divided into twenty-

seven chapters, and, beginning with the origin and early progress of the steam engine it leads on to the various types or engines in use at the present time. It has also an important section comprising questions and answers on steam and electrical engineering. There is much valuable information in the work not generally found in books of this description such as the duties of stationary engineers, with a concise history of the State and local laws in regard to licenses and other important subjects. The book should be carefully studied by all who have charge of steam plants.

Concrete Factories, by R. W. Lesley, published by Bruce and Banning for the Cement Age Company, 1907, New York, 152 pages. Price, \$1.00.

This is an important addition to cement literature, and consists of a series of papers descriptive of the uses of cement and concrete as applied to the construction of industrial plants. In addition to the presentation of the most complete reviews of the principles underlying reinforced concrete construction that has yet appeared in one volume, the book contains the reports of the United States Advisory Board on Fuels and Structural Materials, the report of the Sub-Committee on Tests, and a translation of the recently published French rules on reinforced concrete. The book is profusely illustrated and Mr. Lesley, who is an associate member of the American Society of Civil Engineers, has the happy faculty of presenting the descriptions in a plain style that is readily understood, and the book is sure to meet with a favorable reception by all who are interested in the great and growing industry of cement and concrete construction.

Henley's Twentieth Century Book of Recipes, Formulas and Processes, by G. D. Hiscox, M. E. Published by the N. W. Henley Publishing Co., 1907, New York. 787 pages. Cloth, price \$3.00.

This book, as its title implies, is a vast collection of useful information essential to scientific, chemical and technical processes and formulas for use in the laboratory and the workshop to which are added household recipes to meet almost every existing requirement in the home or office. The editor has successfully brought together a compendium that meets the needs of the mechanic, the manufacturer, the artisan and the housewife. Much of the matter is entirely new to American readers, as special translations have been made for the work from foreign technological periodicals and books. Old recipes which have stood the test of time are properly included, and the well-known painstaking work of the editor is a guarantee that what is new in the book will properly

take rank with what has been already proved of value. The alphabetical arrangement of the ten thousand different subjects makes the information required available at once.

#### Steel Box Car for the U. P.

The Union Pacific Railroad, of which Mr. W. R. McKeen, Jr., is Superintendent of Motive Power and Machinery, have recently turned out of their own shops, at Omaha, Neb., two styles of box cars built entirely of steel.

Looking at our illustrations it will be seen that one of these cars is made with side sills having a short form of truss construction, while the other has a long form of truss construction on the outside sills. The short truss rod car, No. 72850, is 40 ft. long inside, 8 ft. 10½ ins. wide inside, and the inside height to the top of the curved roof is 7 ft. 10 ins.

The short truss car has a centre door 8 ft. wide, and the sides are made with 4 panels on each side of the door stiffened with tee irons, 4 by 2 by 5-16, counter-braced with angles 3½ by 2½ by ¾ ins.

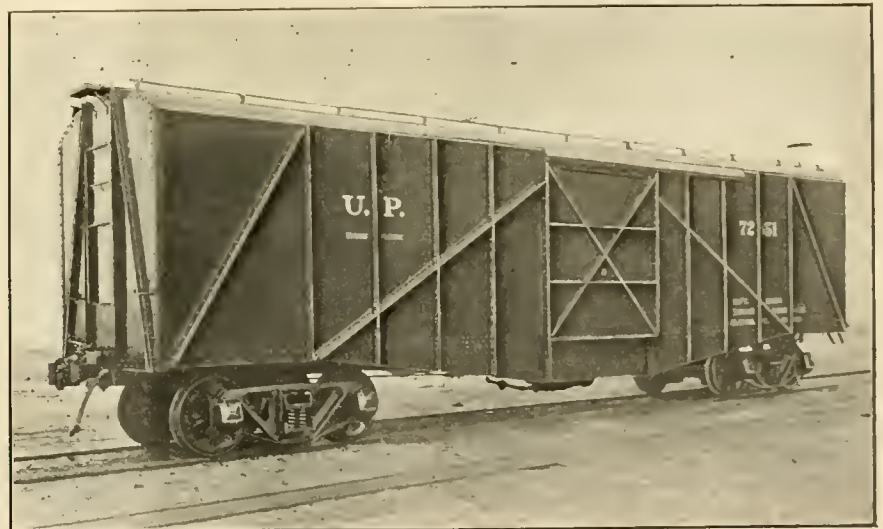

ONE EXAMPLE OF A UNION PACIFIC STEEL BOX CAR.

The centre brace for the two panels next to the door is approximately of arch construction. The base of this brace runs down on to the truss-shaped sill below the door. The brace, which is an angle similar to the others, encroaches slightly upon the open space of the door at the top, runs along on the top plate of the car and down through the other panel in similar style.

The centre sill of the car, for there is only one, is an I-beam, 15 ins. deep and weighing 42 lbs. to the foot. This centre sill extends beyond the centre of the body-bolster, a distance of 17 ins. The extension of the centre sill from this point is made of two channels weighing 20½ lbs. to the foot. These are spaced 12¾ ins. apart and constitute the draw sills in which the Sessions draw gear is carried.

The side sills are angles 5 by 3 by 5-16

ms., to which are riveted the bottom of the side plates. This side construction is therefore of the bridge type, and in fact the whole car may in a sense be called a modification of the box-girder which was used in some of the earlier forms of railway bridges.

The bracing of the underframe is designed so as to give great stiffness longitudinally, which enables the car to resist all buffing and pulling shocks to which it will be subjected. These braces run from the centre sill to the side sills in a diagonal direction, and are angles 5 by 3½ by 5-16 ins. The centre and outside sills are also bound together by angles on tie rods at right angles to the sills, and the needle beams are composed of channels.

The roof is practically semi-elliptical and is supported by 2½ in. angles spaced 2 ft. apart. These angles are the carlines of this roof. The curved roof has a pair of handrails running along the top on each side, each rail being 3 ft. from the centre of the car. The body-bolsters of cast steel made in two pieces secured to the centre sill by top and bottom cover plates.

The weight of this style of car is 37,750 lbs. Its volume is 28,000 cu. ft. The capacity of the car is 100,000 lbs.

The car with the long truss arrangement is No. 72851, and is similar in underframe construction, trucks and other details, but the slope of the truss arrangement is more gradual and begins and ends at the body-bolsters of the car. It has a depth of 22 ins. under the door, which is similar to the other car. The centres of draw sills are also similar to those of the other car. The principal difference is in the truss arrangement to which we have just referred, and in the bracing of the side of the car.

The side of box car No. 72851 is made up of 5 panels on each side of the door, which is 6 ft. wide. Four panels on each side of the door are 2 ft. 9¼ ins. wide, and are made with upright tees, 4 by 2

by 5-16 ins. The end panels extend from the body-bolster to the end of the car and have each one angle counter-brace  $3\frac{1}{2}$  by  $2\frac{1}{2}$  by  $\frac{3}{8}$  ins. The diagonal bracing of this car frame consists of a pair of angles  $2\frac{1}{2}$  by  $2\frac{1}{2}$  by 3-5 ins., placed back to back and laid on the inside or wide flange of the tees. At the intersection of the diagonal



END VIEW OF STEEL BOX CAR.

brace of the upright tees are quarter inch plates which add considerably to the stiffness of the frame. The upper angle of this long diagonal brace is carried over the door in a similar manner to that of the other car. The side bracing of this car between the body-bolsters consists of the truss side sill and the diagonal brace which passes over the door, and forms in a sense, a double arch. The two designs of cars are very much alike. The light weight of this last mentioned car is 38,050. It has a volume of 2,800 cu. ft., and has a capacity of 100,000 lbs.

Both cars are made of No. 15, B. W. G. plate. The stability of each car is therefore depended upon the bracing, though the side sheets lend a certain amount of stiffness to the whole construction. The roof is made out of 1-16 steel in. plates. The floor plates are No. 10 B. W. G., and the running boards are of wood. The designs were prepared under the supervision of Mr. McKeen, to whom we are indebted for photographs and prints. The object of building these cars was to test the merits of the two methods of construction. The bridge truss and the plate girder when applied to modern steel car construction is generally found associated with structural steel shapes, and these cars seem to combine few parts yet make a strong and stiff form of vehicle. The cars are, of course, fire-proof and should prove very serviceable in heavy and hard service.

### Evolution of the Car.

The development of the wheeled carriage can be traced to the war chariot. The earliest record found of a carriage proper being used was when Charles of Anjou and his queen entered Naples in 1280 riding on a caretta. When an imitation of this article of supreme luxury was first seen in England, the word caretta was shortened to car, but under the Norman sway it was Frenchified into chariot or coach, the latter word being a corruption of the word coucher—to recline.

Through long years of development the rude, springless wheeled box grew into the comfortable covered coach carried on steel springs or leather thongs. The luxurious ideas that first demanded elaboration of the carriage took the form of highly ornate carvings and heavy gilding. The ancient specimens of the carriage-makers' art, still preserved in the museums of Europe, are wonders only for the laborious efforts that had been devoted to making them costly possessions.

The covered carriage originated in a small canopy, supported by four pillars, with curtains for front and side protection. It was not till after Queen Elizabeth's time that glass was used as a comfort and protection in carriages, although very ornate trappings were attached to them before that period.

Charles Pepys notes in his famous Diary that on "May 1, 1665, after dinner I went to the tryall of some experiments about making of coaches go easy, and sev-

The arrangement of springs mentioned by Pepys was probably only fine by comparison, for after the middle of the eighteenth century springs were not used except for the more luxurious style of carriage. A French writer of that time mentions the application of springs to the four corners of a perch carriage. The springs were fastened to upright posts, and leather braces went from the top of the springs to the bottom of the body, causing excessive swinging, jerking and tilting when the vehicle was in motion.

Toward the end of the eighteenth century, carriage building became one of the most perfected trades in Europe. A carriage that was used by the Emperor Napoleon during part of the Russian campaign is preserved in a London museum and is a model of convenience, comfort and strength. The French Academy of Arts encouraged the best kind of work in the carriage-building trade, and the vehicles built would have compared favorably with the work of to-day.

When attempts were first made to apply steam to the propulsion of vehicles on common roads the carriages used for the purpose were models of strength and lightness. The carriage or its propelling mechanism was in no way responsible for the failure of the first automobiles.

The first passenger cars used upon American railways were road-carriage bodies placed upon frames carried by flanged wheels. The pioneer American railway engineers not being hampered by the necessity of adhering to ancient

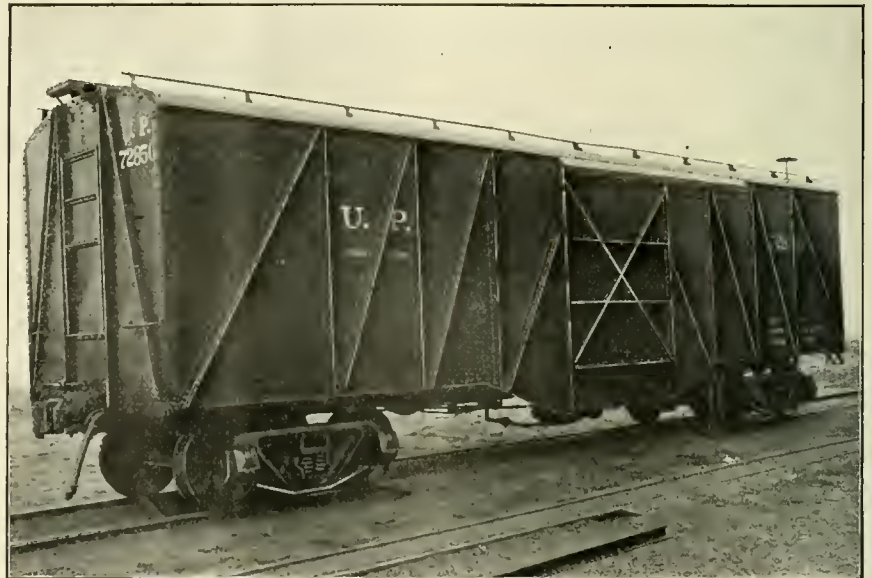

ANOTHER TYPE OF ALL STEEL BOX CAR ON THE UNION PACIFIC.

eral we tried, but one did prove mighty easy (the whole of the body lying on one long spring), and we all, one after another, rid in it, and it is very fine and likely to take." That is the first authentic account of a decided improvement in the arranging of carriage springs, but they had been used in a crude form previously.

forms, soon discovered that the road coach was not adapted to railroad trains and they devised a car suitable for the purpose, and from it developed the modern passenger car. In Europe they worked on the line of developing the road coach to suit railway conditions, and it resulted in the compartment carriage.

# Correspondence School

## Fourth Series—Questions and Answers.

1—What is your understanding of steam pressure, as shown by the steam gauge?

A.—The pressure shown on the steam gauge is that of the steam above the atmosphere. Atmospheric pressure at the sea level is 14.7 lbs. to the sq. in., and pressures above this are registered on the steam gauge. For example, 100 lbs. on the steam gauge is really 114.7 lbs. absolute pressure, or 114.7 lbs. above vacuum.

2—What is the result of exhaust steam going through stack?

A.—It produces a draught on the fire.

3—In what way does the exhaust steam create draught on the fire?

A.—When the exhaust steam leaves the exhaust nozzle it passes upward and fills the smoke stack, and, so to speak, pushes a stackful of gas out, and this creates a partial vacuum in the smoke box, and the heated gases from the fire box rush through the flues to supply the deficiency and a partial vacuum is caused in the fire box and air from the outside rushes in through the grates and thus stimulates the fire.

4—Will air enough come through the grates and fire to form perfect combustion of the coal?

A.—Not in the case of the locomotive. The grate area is comparatively small and so much coal has to be burned on its surface in a given time that an artificial draught caused by the action of the exhaust is necessary in order to obtain practically perfect combustion.

5—Is it necessary to admit any air above the fire?

A.—It is good practice and very satisfactory results have been obtained when it is properly done.

6—What is the object of the hollow stay-bolts?

A.—Hollow stay-bolts sometimes are used in order to facilitate the passage of air into the fire box above the fire.

7—What is the object of holes in the fire-box door?

A.—Where there are holes in the fire-box door they are generally put there for the purpose of introducing air into the fire box, above the fire.

8—Will the cold air mix with the gases from the coal and burn at once, or must it be heated first?

A.—Cold air should be heated before mingling with the gases distilled from the coal in order to cause the more complete combustion of the gases.

9—What effect would a very small exhaust nozzle have on the fire?

A.—A very small nozzle will produce a very sharp and powerful draught on the fire, and will tend to make air pass strongly in through thin places or otherwise cause holes in the fire.

10—When the fire burns most in the front end of the fire box, what does it indicate?

A.—It indicates that there is something wrong with the drafting of the engine which makes the hot gases pass through the lower flues more readily than those higher up. In other words, the passage of gas through the upper flues and under the diaphragm plate is hampered in some way more than that through the lower ones.

11—How is this remedied?

A.—This is done by the careful adjustment of the diaphragm plate and keeping all the flues clean.



BRIDGE OVER THE SUSQUEHANNA RIVER AT ROCKVILLE, PA., ON THE PENNSYLVANIA.

12—What is the object of the brick arch?

A.—The brick arch is intended to retard the passage of coal gas from the fire to the flues by preventing the gases being drawn directly into the flues.

13—Does it save coal? How?

A.—Yes, in many cases it does. The brick arch by delaying the heated gases from the fire cause them to be more thoroughly mixed with air and so more thoroughly burned with greater evolution of heat. When coal is thoroughly burned a less quantity of coal is needed to do a certain amount of work than that required to do the same work, if improperly burned.

14—Explain how you would fire an engine to make her steam well, run light on coal and avoid unnecessary smoke?

A.—I would fire lightly and often, keep the fire as nearly as possible of an even but sufficient depth for the work the engine has to do.

15—How do you keep smoke from trail-

ing over train when running shut off?

A.—The light use of the blower may often prevent this, but the way to fire is to avoid the formation of smoke by securing as far as possible the complete combustion of the coal by firing as indicated in the answer to question No. 14.

16—What effect does it have upon the fire to open the fire-box door when the engine is working?

A.—Opening the fire box door when an engine is working generally introduces too much cold air above the fire. It checks the draught through the fire caused by the exhaust and it often cools the distilled gases below their igniting point and prevents complete combustion.

17—What effect does wetting the coal have?

A.—Wet coal is more convenient to handle, especially if it is very fine coal, as it prevents dust and the finer particles from being caught up by the draft and drawn into the flues before they fall upon the fire.

18—What will you do with a fire that is banked?

A.—In order to get a banked fire ready for the road the coal must be raked back over the grate and more coal thrown on in order to cover the entire grate area.

19—How does the blower operate?

A.—The blower operates in much the same way as the blast from the exhaust. It creates a partial vacuum in the smoke box. It is not as strong in its action as that of the exhaust but it is continuous, while the exhaust acts intermittently.

20—Do you use it on a free steaming engine to prevent dense black smoke when shut off?

A.—Not as a rule. The endeavor should be to fire an engine so that heavy black smoke will not be formed. In case of emergency the blower may have to be used.

## Elements of Physical Science.

### MATTER AND FORCE.

Matter is that substance which is perceived by the senses and occupies space, and may be said to be divided into substances, of which earth, water and air are the chief varieties. All portions of matter of whatever size or structure are called bodies. The constant change of form in substances is caused by Force, and whatever acts on a body producing a change in the form of that body, or a change in its relation to other bodies, is a force. Heat, electricity and light are thus called forces. All the phenomena in the material universe are produced by force.

Bodies are said to be solid when their particles have the quality of cohesion and offer resistance to impressions or penetration by other bodies. A body is said to be liquid when the element of cohesion is so slight that the particles move freely around each other and offer little resistance to penetration by other bodies. Bodies of gases and vapors are said to be aeriform and have the quality of diffusion, but in a general way liquid and aeriform bodies are classified as fluids. It may be remarked that the same substance may appear under different circumstances in all of these forms. Water is a liquid, but when frozen it becomes ice and assumes a solid form, and when exposed to heat it is converted into steam, which is aeriform.

Bodies are distinguished either as simple or compound, simple bodies being those that can not be resolved into more than one element. Compound bodies consist of matter that can be resolved into more than one element, as air or water, which is each composed of two gases. The simple bodies are being added to from time to time by reason of scientific discoveries. Among these about sixty are metallic bodies and are distinguished by a peculiar lustre. The remainder, less than twenty in number, are classified as non-metallic elements. It may be noted that the simple substances are extremely rare, nearly all substances in nature being compound, while some of the simple substances are so rare that their properties are not fully known, the compound bodies forming the vast bulk of the substances of the universe. The consideration of simple substances belongs to the science of Chemistry. Chemical affinity may be said to be the force that produces compound substances. This mysterious affinity exists only between certain substances. The science of Natural Philosophy treats of the properties and laws of matter, and, briefly stated, may be said to be a search for truth in the material world.

#### PROPERTIES OF MATTER.

Certain properties are inherent in every particle of matter. Some are common to all bodies, and are called universal properties of matter. Others are allied to certain substances only and are known as accessory properties.

The universal or general properties of matter are compressibility, divisibility, expansibility, extension, figure, gravitation, impenetrability, indestructibility, inertia, mobility and porosity. The chief accessory properties are adhesion, brittleness, cohesion, ductility, elasticity, hardness, malleability and tenacity.

Compressibility and expansibility are the opposites of each other and both follow from porosity. The particles of bodies do not everywhere touch each other, and force will bring them closer together, as in the case of a sponge. If the pores are made larger, as is the case by heating some bodies, the size of the body is increased.

Divisibility is that quality which renders a body capable of being divided. It is claimed that there is practically no limit to the divisibility of matter. Small particles are called atoms and a fine illustration of the divisibility of matter into atoms may be seen by dissolving a grain of copper in nitric acid and the atoms of copper will impart a blue color to a gallon of water.

Extension is that property of a body which has a certain size filling a portion of space. This portion is called its piece, and is distinguished by dimensions embracing length, breadth and thickness. Figure is allied to extension, the form of solids being permanent, while that of fluids varies, adapting it-



BALDWIN, MALLETT. ARTICULATED COMPOUND ON THE GREAT NORTHERN.

self to every new surface with which it may come in contact.

Gravitation is a force inherent in all bodies by virtue of which they tend to draw every other body to themselves, in a ratio to their size and density. Impenetrability is that quality whereby bodies occupy certain spaces to the exclusion of other bodies, and in virtue of which no two bodies can occupy the same space in the same time. Indestructibility is that property which renders a body incapable of being destroyed. All matter is possessed of this remarkable quality, and while matter may assume new forms and even new properties it cannot cease to exist. It may be noted that the apparent destructibility of matter as in the case of the evaporation of water is not in any sense a loss of water—it is merely a temporary changing of form, the water falling to the earth again as soon as the vapor is condensed.

Inertia is that property which renders bodies incapable of putting themselves in motion or coming to rest when in motion. The heavier a body is the greater is its inertia. Mobility is that property which renders all bodies capable of being moved. All

bodies also possess the quality of porosity in a greater or less degree. The porosity of water is best illustrated by heating the water, which causes expansion or a forcing of its particles farther apart from each other. Although the vessel is entirely filled with the heated water a quantity of salt or sugar can be slowly added without causing the water to overflow, showing that the salt or sugar finds a lodgment in the spaces between the atoms of water.

Of the accessory properties of bodies perhaps the most interesting is the varying tenacity of different substances. Experiments have shown that the breaking point of metals as tested on a transverse section of a square inch is as follows: Cast steel, 135,000 lbs.; Swedish iron, 75,000 lbs.; common iron, 53,000 lbs.; cast iron, 19,000 lbs.; cast copper, 19,000 lbs.; cast tin, 4,800 lbs.; cast lead, 1,800 lbs.

#### MECHANICS.

Mechanics may be said to be that particular branch of science which treats of forces and their application to machines. Under the heading of mechanics belong Pneumatics, which treats of gases and vapors. Hydraulics and hydrostatics relate to liquids in motion or at rest. Electricity relates to the force so called, and embraces galvanism, which treats of electricity produced by chemical action, thermo-electricity, which treats of electricity developed by

heat; magnetism, which treats of magnets and the forces they develop including magneto-electricity, which treats of electricity developed by magnetism, and electro-magnetism, which treats of magnetism developed by electricity.

To these elemental forces embraced under the general heading of Mechanics should be added Pyromonics, which treats of heat; Optics, which treats of light and vision; and Acoustics, which treats of sound. Astronomy may also be classed in Mechanics, treating of the heavenly bodies, and Meteorology, which treats of the phenomena of the atmosphere.

When a body moves, or being in motion, ceases to move, or changes its motion, it is safe to assume that it is being acted upon by an external force. That which offers opposition to Force is called Resistance. The flight of an arrow is an illustration of Resistance and Force. The inertia of the arrow is Resistance, the bent bow may be taken as representing a Force sending the arrow through the air, the wind affecting its direction is a Force. Gravitation, which reduces the velocity of the arrow, and brings it to the earth, is a Force.



## Questions Answered

### ARTICULATED COMPOUND.

(41) T. D., Jr., Richmond, Va., asks: Why is the great compound on the Baltimore & Ohio Railroad called the Mallet Articulated Compound?—A. The engine is called Mallet after a French engineer by the name of Anatole Mallet, who designed two small engines of this type, which were used for a time on the Bayonne and Barritz railway. It is called "articulated" because its frame is jointed. The driving wheels are arranged in two sets of six wheels each. The forward set with their cylinders are in a frame having a joint or pivot point just under a swinging joint in the steam pipe. This plan is equivalent to the mounting of the engine on two motor trucks. The engine is also a compound. See the description of a similar articulated compound engine built by the Baldwin Locomotive Works for the Great Northern, which was illustrated and described in the October, 1906, issue of RAILWAY AND LOCOMOTIVE ENGINEERING, page 472.

### HORSEPOWER OF A LOCOMOTIVE.

(42) C. E. F., Taunton, Mass., writes: Given the tractive power of a locomotive in pounds, how can I find the horsepower? Will you please give the method for a locomotive of, say, 25,000 lbs.—A. The tractive effort of a locomotive is not necessary in this calculation. The formula for the horsepower is

$$HP. = \frac{P \times L \times A \times N}{33,000}$$

Where P is the mean effective pressure in the cylinders, say, 85 per cent. of the boiler pressure; L is the stroke in feet for one entire revolution, an engine with 24-inch stroke would have a value of 4 for L; A is the area of the piston in square inches, and N is the number of revolutions of the driving wheels per minute. The product of these divided by 33,000 gives the horsepower of the engine. The denominator 33,000 is the number of foot-pounds of work which, if performed in one minute, constitute what is called one horsepower.

### ELECTRIC NIGHT.

(43) G. E. C. and E. E. N., Brooklyn, N. Y., write: We read the speeches about the electric locomotive at the New York Railroad Club and would like to know how you get an electric locomotive out of a steam locomotive, when a steam locomotive generates its own power, but an electric locomotive is fed by the power house? A.—You do not get an electric locomotive out of a steam locomotive, the two are separate. What Mr. Sinclair pointed out at the Electric Night Meeting of the N. Y. Railroad Club was that steam locomotive designers had

originally tried to build machines with low centre of gravity. On pages 183 and 184 of our April issue we give three samples of how early builders in Great Britain and in France tried to do it. Very low centre of gravity was not found to be an advantage for steam locomotives. Our designers of electric locomotives have tried for and have got low centre of gravity for their electric machines, and it is not any more advantageous for them than it was for steam locomotives. Mr. Vaucelain pointed out how European Electric Locomotive designers had kept the centre of gravity high. It is by placing the motors above the axle level or above the frames, and making them drive the wheels by connecting rods. On page 182 we show the armature of the Simplon electric locomotive, with pin for attaching the connecting rod to. The point these gentlemen made in their speeches was that as low centre of gravity had not been found advantageous with steam locomotives why introduce it into the designs for new electric locomotives which have to run over the same track and do the same work that steam locomotives do? Read the Electric Night speeches over again.

### RUNS BEST BACKWARD.

(44) A. A. G., Hagerstown, Md., writes: We have a locomotive that works best running backwards. How is this accounted for? A.—Nothing else could cause such a condition except some particular variation in the adjustment of the valve gear. It would be interesting to have the valve gear carefully examined and have the forward motion made to agree with the backward motion. Locomotives generally will work as well one way as the other, the only difference being that the sanding attachments are adjusted for the most usual service, which is while the engineer is running forward.

### CURIOUS WHISTLING.

(45) R. G., New Haven, Conn., writes: Could you tell us what is the cause of a whistle varying in sound? A.—Several causes will produce a variation in steam whistles. Strong winds that partially deflect the thin film of steam will cause a variation of sound. Too much water in the boiler, causing a rush of water with the steam to the whistle, will also change the sound. It should be observed that the cap must be perfectly straight and also screwed tight in its place.

### SETTING SLIPPED ECCENTRIC.

(46) J. B., Hornellsville, N. Y., asks: What is the quickest and best method of putting a slipped eccentric back in its right place? A.—There are several methods of setting a slipped eccentric that can be applied to suit the circumstances. If it is either of the eccentrics nearest the center of the axle there are nearly always marks that have been made upon the axle

by which the eccentric may be readjusted. It is safe to observe the position of the eccentric remaining in place and its exact relation to the position of the crank pin. The loosened eccentric should be moved to a similar distance from the crank pin on the opposite side of the axle. For example, if the crank pin was on the top center as in the place of the twelfth hour on the dial of a clock, and the largest part of the eccentric remaining in place was located at a point a little past nine o'clock, it would be safe to adjust the loose eccentric with its extreme point of extension at a point approaching to three o'clock. A common practice is to place the engine on the dead center and bring the reverse lever to the extreme end of the quadrant. The valve will then be controlled by the eccentric remaining in place. Then mark the valve rod at the steam chest gland. The lever can then be moved to the other end of the quadrant and the loose eccentric can be shifted until the mark on the valve rod corresponds, taking care that both eccentrics are not set in the same position.

### HEAVY ENGINES.

(47) T. D., Jr., Richmond, Va., asks: What type and on what roads are the largest freight, passenger and switching locomotives in the United States?—A. It is impossible to state positively which road has the heaviest locomotives unless considerable data from all over the country were before us. We may say, however, that the Pennsylvania have a class of heavy passenger engines of the 4-6-2 type. The Oregon Railway & Navigation Co. have also some very heavy passenger engines. The B. & O. Mallet Articulated engine and the Great Northern Mallet engine are probably the heaviest freight engines in use. Compare the descriptions of these engines as given in RAILWAY AND LOCOMOTIVE ENGINEERING. The heaviest switchers are probably an eight wheel coupled engine on the Chicago & Eastern Illinois, a 0-10-0 belonging to the Michigan Central and a 0-6-0 used on the N. Y. C.

### DIRECT ACTING ENGINES.

(48) J. D., Staten Island, N. Y., writes: I see occasional mention made of direct acting engines. What is the difference between direct and indirect engines?—A. A direct engine is one where the connecting rod joins the cross head at one end and a revolving crank at the other. An indirect engine has some other mechanical device between the main rod and crank, as in the case of the beam engine.

### WEIGHT OF CAST IRON BALLS.

(49) J. McQ., Chicago, Ill., asks: What is the rule in regard to the weight of a cast iron ball?—A. The common rule is to multiply the cube of the diameter by .1365. Thus, if a ball were 5 inches in diameter, multiply  $5 \times 5 \times 5 \times .1365 = 17.0625$  lbs., or 17 lbs. 1 oz.

### South Shore Switcher.

A very sturdy looking six-wheel switcher has recently been turned out by the Baldwin Locomotive Works for the Duluth, South Shore & Atlantic Railway. There are eight of them in the order and they were designed for service on a line having  $2\frac{1}{2}$  per cent grades, 14 degree curves and of course switches and turnouts innumerable.

The cylinders are 21 x 28 ins., the drivers are 31 ins. in diameter and with 200 lbs. steam pressure the tractive effort of the engines comes up to 41,160 lbs. The weight of the whole engine is adhesive weight and it is 165,300 lbs. The ratio of tractive effort to adhesive weight is therefore as 1 is to 4. The wheels are all flanged and are spaced 60 inches apart with four inches additional between the main and intermediate wheels where the rocker comes through. The tires have  $\frac{3}{4}$  of an inch play in order to facilitate

No. 11 gauge, 2 ins. outside diameter, and there are 276 of them, each 16 ft. long. The boiler itself is 68 ins. in diameter at the smoke box end. The fire box is  $96\frac{1}{8}$  ins. long by 66 ins. wide and measures  $64\frac{1}{2}$  ins. deep at the front and  $62\frac{1}{2}$  ins. at the back. There is a 4-inch water space all around the box. The grate area is 44 sq. ft. and the ratio of the grate area to heating surface is as 1 is to 55.8.

The tank has a sloping back, with a water bottom in front. The fuel space extends the full width of the tank and has a sloping floor throughout almost the entire length. The fuel capacity is 8 tons, and 5,000 U. S. gallons of water are carried in the tank. The tender has 30-inch wheels placed in ordinary arch-bar trucks. The total weight of the engine and tender together in working order is about 265,300 lbs. and the total wheel base for the two is 44 ft.  $6\frac{1}{2}$  ins. The engine

Directors of the Pennsylvania Railroad, when it was agreed to accept the offer of Anne Thomson, Frank Graham Thomson and Clarke Thomson to give \$420,000 for the establishment of what is to be known as the Frank Thomson scholarships. It is the desire of the persons who establish the trust to afford to "sons of living or deceased employees of all the lines of the railroad an opportunity for a technical education, so as better to enable them to qualify themselves for employment by the company."

The fund has been deposited with the Fidelity Trust Company of Philadelphia as trustee. Competitive examinations are to be held for the scholarships. The company in selecting boys for the scholarships is permitted to take into consideration not only the standings of the candidates but also the physical and moral qualifications.

After passing the examination held by

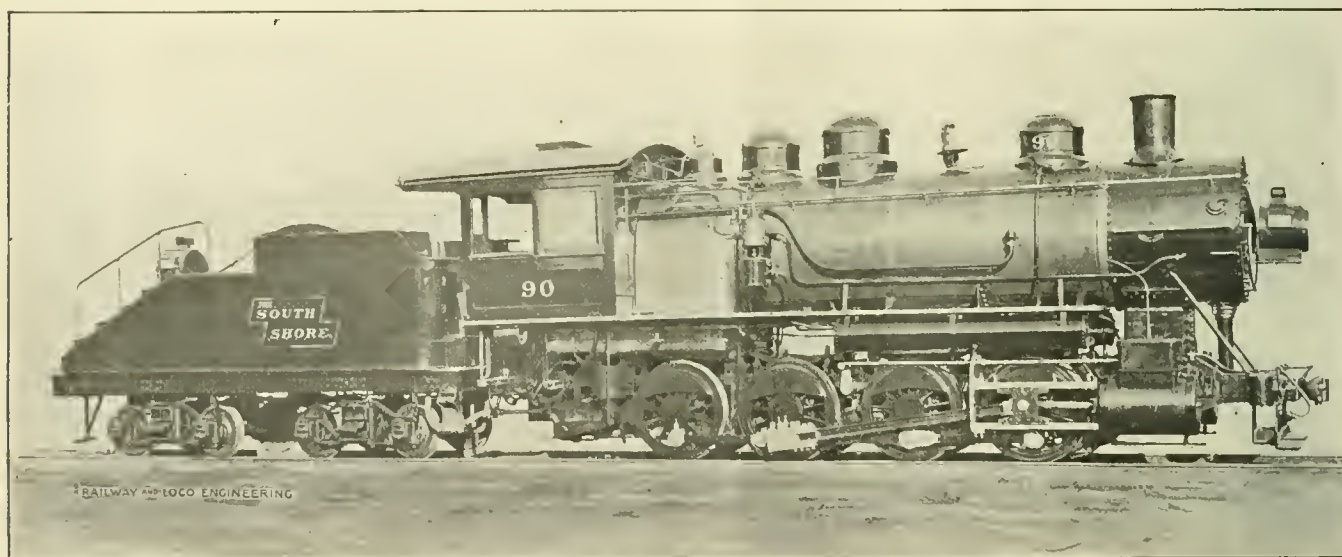

SIX-WHEEL SWITCHING ENGINE ON THE D., S. S. & A.

J. J. Conolly, Supt. of Motive Power.

Baldwin Locomotive Works, Builders.

movement through switches and curves.

The cylinders are single expansion, with slide valves which are driven by Stephenson link motion. The rocker shafts are placed between the first and second pairs of driving wheels and are connected to the link blocks by short transmission bars. The long valve rods are supported in the guide yokes. The main rods are of I section with strap stubs at the rear, while the side rods are rectangular with solid end stubs throughout.

The boiler is of the straight top type, with a wide fire box having a sloping back head. The mud ring is supported in front on sliding shoes and at the rear on a buckle plate which is bolted to cross-ties. The heating surface is made up of 130 sq. ft. in the fire box and 2,318 in the tubes. This gives a total of 2,457 sq. feet. The tubes are iron,

wheel base is 15 ft. 4 ins. Some of the principal dimensions are given below:

Boiler—Material, steel; thickness of sheets, 11/16 in.; fuel, soft coal; staying, radial.  
 Fire Box—Material, steel; thickness of sheets, sides,  $\frac{3}{8}$  in.; back,  $\frac{3}{8}$  in.; crown,  $7/16$  in.; tube,  $\frac{1}{2}$  in.  
 Driving Wheels—Journals, main,  $9\frac{1}{2} \times 12$  ins.; others,  $8 \times 12$  ins.  
 Tender—Journals,  $5 \times 9$  ins.

### Frank Thomson Scholarships.

There is no railroad in the world where that sentiment of love and pride known as *esprit de corps* is so prevalent as on the Pennsylvania Railroad. This friendly spirit which often manifests itself in friendly acts toward fellow employees and their families has been strikingly displayed lately in a most helpful bequest which no doubt originated with Frank Thomson. The generous act was made public at a meeting of the Board of

the company every successful candidate must qualify for admission to one of the technical schools or colleges approved by the company before he is eligible to receive the scholarship.

Beginning this year two scholarships, each of \$600, are to be filled. Two are to be added to the list each year and ultimately it is expected eight men will be kept in college by the gift.

This is one of the most valuable forms of benevolence we know of, since it puts young men of ability in a position to help themselves into the higher ranks of life. Frank Thomson himself was helped onwards by the limited opportunities the Pennsylvania Railroad Company then possessed for giving special training to young mechanics and he appears to have appreciated the benefit to the railroad company which comes from having more men of the educated mechanic class.

# Air Brake Department

CONDUCTED BY J. P. KELLY

## S F 4, Pump Governor.

Among the innovations introduced with the E T locomotive brake equipment was one affecting the method of regulating brake pipe and main reservoir pressure so that the desired amount of both might be had during the various manipulations of the automatic brake valve. As the feed valve supplied with this equipment is designed to permit of quick and easy adjustment, in changing from the ordinary to the high speed brake pressure, it was thought advantageous to supply a pump governor that would automatically adjust the relation of the brake pipe and the main reservoir pressure so as to maintain the desired excess, whenever this was done. The type of governor supplied to do this is known as the S F 4. Concerning some of its peculiarities in operation, a correspondent in the April number, Mr. G. W. Kielm, has made some clear and satisfactory explanations.

As he points out, when the engine is coupled to a long train of cars that are to be charged up from zero or from a low pressure, after the air is cut in, if the handle of the automatic brake valve is allowed to remain in running or in holding position while so doing, the pump will stop immediately, and it will not start again until the main reservoir and the brake pipe pressure nearly equalize. After equalization is nearly effected, which may require some seconds, the governor will permit the pump to go to work, and it will continue to work until the system is fully charged.

The reason the pump stops when the air is cut in with the handle of the brake valve in running or in holding position is, as pointed out by the correspondent, because the diaphragm of the excess pressure top always has main reservoir pressure under it, while it has above it under normal conditions feed valve pipe pressure (F. V. P.), combined with the excess spring pressure. Cutting in a long empty train under the conditions cited permits the feed valve pipe pressure to fall to a point considerably below main reservoir pressure, thus giving the latter an opportunity to raise the diaphragm and its pin valve, and hold them up for a period of time such as is required by the main reservoir air to flow through the feed valve into the brake pipe, and nearly equalize.

This peculiarity of the governor, in holding the pump stopped for a few seconds, at first was regarded as an undesirable feature, and it was to some extent criticized; but as time advances and experience in the use of the E. T. brake broadens it is coming to be regarded as a desirable feature since it causes the one manipulating the brake to carry the handle in release position while charging, releasing and recharging, which, of course, is the proper one for these operations.

During all the years of our brake manipulation much annoyances and damage in the shape of stuck brakes, break in twos and delays have been caused by releasing with the handle in running position; and this defect is being rapidly corrected by the S F 4 governor and E T brake, simply because the pump does stop, and it notifies



DYNAMITE USED ON A TRAIN IN THE SOUTH AFRICAN WAR.

the engineer by so doing that there has been an error made in manipulation. One other feature treated by our correspondent is that of the effect on the S F 4 governor of slight leakage through the feed valve when the handle of the brake valve is allowed to remain in release position too long, which causes the governor to fail to stop the pump when the required main reservoir pressure is obtained. The reason it allows the pump to continue to work until the pressure for which the high pressure top is adjusted is obtained is as stated, namely, a very small volume of feed valve pipe into which a slight leakage can quickly increase pressure and maintain it, above the excess pressure diaphragm, equal to that below it. This condition of pressure above and below the diaphragm enables the governor excess spring to hold the pin valve to its seat, and so prevent the governor from operating. However, this latter defect in operation, though not a

serious one, and due to feed valve leakage alone, has been remedied by supplying the warning port in the rotary with air taken from the feed valve pipe supply instead of from the main reservoir. Since the amount required for this port is always in excess of permissible feed valve leakage, the pressure can not build up in the feed valve pipe while the handle is in release position. Hence the governor can not now fail because of this leakage do regulate the pump as desired.

## Train Weight and Brake Work.

The automatic air brake, in its present state of development, meets the exacting requirements of modern railway service in a manner so satisfactory as to inspire increased admiration for this important mechanical device.

Since, however, the weights of engines and cars, and the length and speeds of trains have increased so much and so rapidly during the past few years, the results, measured by stopping distances, do not fairly indicate the increased work the brakes are now doing over what they accomplished a short time back.

The following facts have an important bearing on this subject:

The weight on the drivers of the locomotive has increased from 25,000 to 270,000 pounds, and the draw bar pull from 10,000 to more than 50,000 pounds. The total weight of the locomotive has increased from 60,000 to 500,000 pounds, and the increase in steam pressure has been from 125 to 225 pounds. These figures indicate very forcibly the increased capability of the modern locomotive both for speed and for power.

In the case of passenger cars the weight has increased from 20,000 to 130,000 pounds, and in some few cases to more than this.

As for freight cars the capacity has increased during the past fifteen years from 40,000 to 110,000 pounds, and the light weight of the car has increased from 12,000 to 48,000 pounds.

The passenger train schedule speeds have increased from thirty miles per hour to sixty-five, and this means, of course, that the actual speed attained often exceeds that given in the schedule.

The energy contained in a five car train of 30,000 pound cars at thirty-five miles per hour is about 6,600,000 foot pounds; in that of a five car train of 127,000 pound cars it is 27,700,000 foot pounds.

At a speed of sixty-five miles per hour the lighter train will have an energy of

22,950,000 foot pounds; the heavier an energy of 96,000,000 foot pounds.

At a speed of thirty-five miles per hour, a locomotive weighing 45,000 pounds has an energy of 1,979,500 foot pounds; one weighing 500,000 pounds, at the same speed, has an energy of 22,898,000 foot pounds. At a speed of sixty-five miles per hour the lighter locomotive has an energy of 6,741,000 foot pounds; the heavier has an energy of 75,970,000 foot pounds.

The energy in a train consisting of the lighter engine and cars, mentioned above, at thirty-five miles per hour is 8,579,500 foot pounds; that in a train consisting of the heavier locomotive and cars at the same speed is 50,598,000 foot pounds. At sixty-five miles per hour, the energy for the lighter train is 29,691,000 foot pounds, and for the heavier 171,970,000 foot pounds.

The brake work required to bring a train to rest varies directly as the foot pounds of stored energy which it contains at the instant the brakes are applied. Hence, a comparison of the energies to be destroyed as shown above will give an accurate estimate of the greater amount of work which the modern brake has to do to stop the train in the same distance that the lighter train can be brought to a standstill. And yet, with the higher speeds and heavier trains the modern brake is able not only to stop in the same, but in less, distance than the former brake operating on the lighter train.

#### Air Brake Convention.

As announced in the April number the Air Brake Association will open its 14th annual convention at the Great Southern Hotel, Columbus, Ohio, Tuesday morning, May 14th, 1907, at 9 o'clock.

The papers to be read and the discussions to follow will, without doubt, prove very important, especially as the air brake art is now in the act of making a vast stride forward, and because many of those who will be in attendance have had much valuable experience with the improved apparatus since the Montreal convention.

Present indications, despite the discouraging aspect of free transportation in some instances, point to a large attendance.

#### Re Transportation.

The following correspondence which passed between the Secretary of the Interstate Commerce Commission and the Secretary of the Air Brake Association is self explanatory, but it serves to show the view of the free transportation question taken by the Interstate Commerce Commission. The roads which do not help their men to attend stand in their own light.

Boston, Mass., October 30, 1906.

Mr. Edward A. Mosely, Washington, D. C.  
Dear Mr. Mosely:

We are receiving a number of discouraging letters from some of our members and have had discouraging discussion with others bearing on the outlook for the future of the Air Brake Association, with particular reference to the matter of free transportation to these meetings. At our last Convention in Montreal, Canada, many of our members were unable to obtain free transportation over the United States Railroads, the officials thereof refusing on account of the strict laws prohibiting them from issuing passes. As you are aware, many of our members are of the lower salaried class in the railroad employ and do not receive free pass consideration that the master car builders, master mechanics, and other officials do. The outlook for our coming convention in 1907 is decidedly gloomy on this account, and we do not expect to have many members in attendance, only those who are employed on roads running into the place where the convention is held and men whose company pay their railroad fare to the convention. This pass restriction, as interpreted by railway officials, seems an unjust hardship on the very members from whom we get valuable information from the firing line of daily experience which has gone so far to build up the Air Brake practice on the Railroads of the United States. It seems an unjust discrimination against innocent parties that the law was undoubtedly not intended to cripple, and the future of the Association looks very gloomy, indeed, and we fear our Association will be disintegrated unless some provision can be made to permit railroads to furnish free transportation to members to attend conventions of this character. Inasmuch as Secretaries of Y. M. C. A.'s can be granted free transportation to their meetings, it would seem that educational meetings, such as the Air Brake Association Conventions, which the railroads benefit from largely, and by which the safety of the traveling public is greatly enhanced, could be arranged.

I take the liberty of thus writing you and placing before you what I consider a decidedly serious situation, hoping that you may see some way by which the Association may secure relief. Both yourself and Mr. Borland are well acquainted with the objects of the Association, the character of its meetings, etc., and we hope you will be able to do something whereby our best active members, those in lowly positions, may be allowed free transportation to the Air Brake Conventions.

(Signed) F. M. NELLIS, Sec'y.

Washington, D. C. Nov. 15, 1906.

Mr. F. M. Nellis,  
Secretary Air Brake Association,  
53 State St., Boston, Mass.

Dear Mr. Nellis:—

Your favor of the 30th ult. was duly received.

I am much disturbed at the tone of your letter, as I have considered the Air Brake Association one of our most helpful instruments in bringing about vastly improved conditions in the inspection and maintenance of railway equipment. Our inspection service has been much benefited by the discussions and papers presented at your conventions, and I feel confident that the railroad companies themselves have been greatly the gainers through these meetings. Your association really bears the same relation to the improvement of the air brake service of the roads as do the Master Mechanics' and Master Car Builders' Associations to the locomotive and car service, and in its chosen field of effort it is fully as useful to the roads as are the latter associations in theirs.

I am unable to see why there should be any difficulty over the pass restriction of the new law. The law plainly states that the prohibition relative to the giving of passes "shall not be construed to prohibit the interchange of passes for the officers, agents, and employees of common carriers, and their families." I am unable to understand why the carriers are not just as free as they ever have been to give passes to their own employees and their families, and, through an interchange agreement, to the employees of other roads, and the families of such employees. Of course, it is a matter that rests wholly with the carriers; they can grant or refuse passes to their own employees and the employees of other roads, in their own discretion, as there is nothing in the law to prohibit them from doing the one thing or the other. Non-employee members of the association cannot, of course, legally be given passes unless they come under the excepted classes mentioned in the law, but the status of employees has in no wise been changed by the law.

It seems to me that if the matter is properly presented to the roads, and they are made to understand the great benefits that accrue to them through the holding of these conventions, a way will quickly be found to overcome the reputed difficulty surrounding the pass provision of the law.

Very truly yours,

(Signed) E. A. MOSLEY, Sec'y.

The Secretary of the Air Brake Association recommends members to call the attention of railway officials to these letters, when they ask for transportation to the convention.

# Electrical Department

## Elementary Principles of Dynamos. II.

In connection with the elementary dynamos shown in Figs. 2 and 3, it was mentioned that the value of the e. m. f. generated depended on the strength of the magnet, that is, on the number of

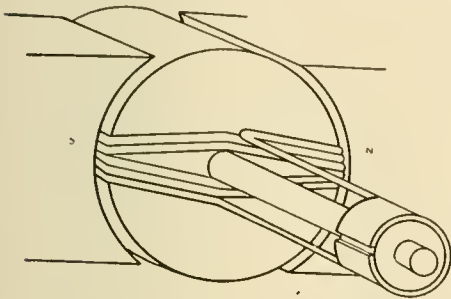

FIG. 4. SINGLE COIL DRUM ARMATURE.

lines of force between its poles. The number of lines of force between the poles of any magnet may be increased by decreasing the gap or air space through which they must travel in passing from one pole to the other. This can be done by partly filling the space between the poles with iron or steel. The effectiveness of the two elementary machines illustrated therefore may be considerably increased by securing the wire to an iron cylinder or ring nearly filling the space between the poles and mounted on the same shaft with the wire and revolved with it, as shown in Fig. 4 or Fig. 5. The revolving part of an electric generator such as is shown in Fig. 4 or Fig. 5 is called the *armature*, and the iron cylinder or ring is called the *armature core*.

If instead of making only a single turn the wire is carried several times around the core so as to form two or more turns before being carried to the commutator or collector rings, the e. m. f. generated by turning the armature at a given speed will be still further increased.

The variation of the e. m. f. in value and direction during the different portions of a revolution has already been explained and also the effect of the commutator in maintaining a constant direction in the outside circuit. The commutator, however, has no effect on the variation in value, and with an armature such as is shown in Fig. 4 or Fig. 5, the e. m. f. will fluctuate from zero to its maximum value during each half revolution as shown in Fig. 6.

If instead of only a single coil and a

two-part commutator, however, additional coils are placed on the armature core, so that when one set of coils is at the position of no e. m. f. the other will be at the position of maximum e. m. f., as in the armature shown in Fig. 7, the fluctuations will be greatly reduced as shown in Fig. 8. By adding still more coils and commutator bars, the fluctuations in the e. m. f. at the brushes can be practically eliminated.

An armature of the form shown in Fig. 7 is called a *ring armature* on account of the form of the core. The same effect can be secured with a cylindrical core by winding each of the four coils on the outside of the cylinder and connecting them together and to the commutator in the same way as before. Such an armature is shown in Fig. 9 and is called a *drum armature*. The ring type of armature is frequently

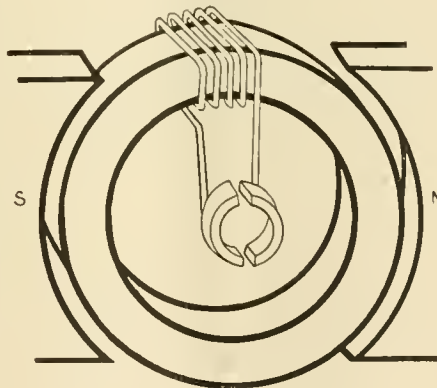

FIG. 5. SINGLE COIL RING ARMATURE.

used in explaining the theory of dynamos and motors on account of the greater ease with which the connections may be followed. In actual machines the drum type is practically always used.

If a wire carrying an electric current is coiled around a piece of iron, the iron immediately becomes a magnet and remains so as long as the current is passing through the coil. Such a device is called an *electro-magnet*. The strength of an electro-magnet depends on the number of turns of wire around it multiplied by the current in amperes which is flowing, that is, on the *ampere-turns*. Thus, if two electro-magnets are exactly alike except that one of them has four turns of wire carrying a current of ten amperes, or forty ampere-turns, and the other has twenty turns carrying a current of one ampere, or twenty ampere-turns, then the

strength of the first should be twice as great as that of the second.

It will be evident at once that an electro-magnet of suitable strength may be substituted for the permanent magnets shown in the previous illustrations, and that as long as current is passing through the coils, the same results will be obtained from the armature as before. Electro-magnets of a given strength can be made more cheaply than permanent ones and all dynamos of any size are always made with electro-magnets. These electro-magnets are called *field-magnets*.

The field magnets of dynamos may be supplied with current in four different ways, all of which are in common use. In the first of these the entire current from the armature of the machine itself is carried through the coils of the field winding before going to the outside circuit, as shown in Fig. 10. This arrangement is but little used for generators, but it is largely used for certain kinds of motors, among which are included all railway motors. Machines which are built to be operated in this way are said to be *series wound*.

The second method of supplying current to the field winding is to connect it directly to the armature, in parallel with the outside circuit, so the current has two independent paths, one through the field winding and the other through the outside circuit, as shown in Fig. 11. This arrangement is in common use both for generators and

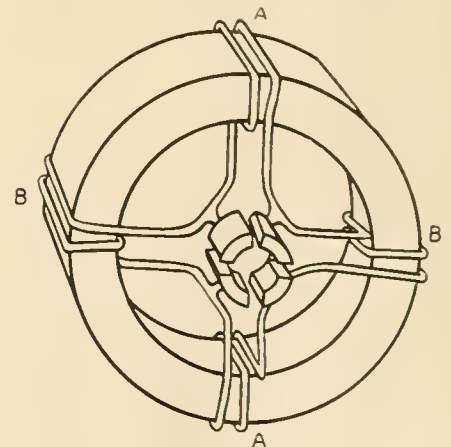

FIG. 7. FOUR COIL RING ARMATURE.

motors. Machines which are connected in this way are said to be *shunt wound*.

The third method is a combination of the first two. The field magnets are supplied with two sets of coils, and

the entire current of the armature is led through one set, which contains only a few turns and is arranged to carry a large current, while the other set contains a large number of turns suitable for carrying only a small current and is connected in parallel with the outside circuit. This arrangement is illustrated in Fig. 12. The majority of modern direct current generators are built in this way. Such machines are said to be *compound wound*.

All three of these types of machines are said to be *self exciting*. The successful operation of machines of this type depends on the fact that when current has once passed through the coils of an electro-magnet, the iron does not lose all of its magnetism when the current is cut off, but retains a certain amount of it, which is called *residual magnetism*. When a self-exciting dynamo is first built, therefore, a current is sent through its field magnets from some outside source, and a certain amount of residual magnetism then always remains. Whenever the armature is first rotated then after a period of inaction, the residual magnetism causes it to generate a small e. m. f. This e. m. f. causes a small current to flow through the field windings, which increase their magnetism. This, of course, increases the e. m. f., which is generated, and in turn increases the current through the field coils and so on until the e. m. f. generated by the armature has reached its normal value.

The fourth method of supplying the field magnets with current is to connect them to some outside source of current such as a battery or another machine, as shown in Fig. 13. The current delivered by an alternating current generator is not suitable for exciting its field magnets, so that the field magnets of alternating current generators are always supplied from a separate source. Machines operated in this way are said to be *separately excited*.

**Erie Electrifies One Division.**

Last summer the engineering firm of Westinghouse, Church Kerr & Co. was retained by the Erie Railroad Company to furnish and instal upon the Rochester division a complete equipment of electric motive power to cover the passenger service of that portion of the main line of the division lying between Rochester and Avon and the branch between Avon and Mt. Morris, being a total distance of about 34 miles of single track besides sidings. The contractors immediately entered upon the work and have now brought it very near to completion.

The equipment which is being in-

stalled represents the latest advance in electrical railway engineering science, and the Erie Railroad is the first steam railroad to get into commercial service upon its lines the new single-phase alternating current system of train propulsion.

which is part of the single-phase equipment. The Westinghouse electro-pneumatic system of multiple unit train control is applied to the cars, by means of which a motorman at either end of any car can control the movement of the train of cars so equipped. These

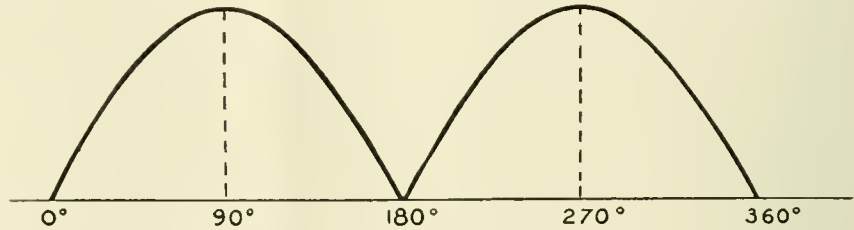

FIG. 6. FLUCTUATIONS OF E. M. F. DURING ONE REVOLUTION OF SINGLE COIL ARMATURE.

The supply of power for operating this electric system is to be derived from the lines of the Niagara, Lockport & Ontario Power Co., which receives the current generated at the new sta-

cars will be capable of a maximum speed of from 45 to 50 miles an hour, and will be able to haul one trailer under any of the conditions of service that are likely to arise.

The trolleys mounted on these cars are of the so-called "Pantagraph" type, consisting of a horizontal cross bar which makes the contact with the overhead wire, and is raised or lowered by a light-jointed framework suitably mounted on top of the car and insulated from it. It is controlled by air pressure and is designed to instantaneously adapt itself to any change in height of trolley wire as when passing under low bridges. This type of trolley, making sliding instead of rolling contact, obviates the annoyance which is so universally experienced by the jumping of the ordinary wheel type of trolley at high speeds.

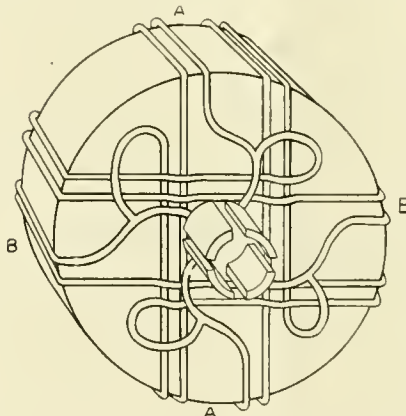

FIG. 9. FOUR COIL DRUM ARMATURE.

tion of the Ontario Power Co. at Niagara Falls, and is now transmitting it at 60,000 volts as far east as Syracuse, where trolley cars of the local

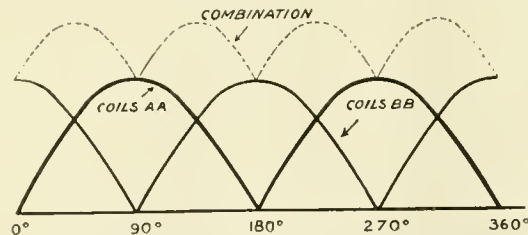

FIG. 8. FLUCTUATIONS OF E. M. F. DURING ONE REVOLUTION OF FOUR COIL ARMATURE.

electric railway system are using it. This long transmission line, which is being constructed in duplicate, crosses the Erie Railroad at Mortimer, about five miles south of Rochester.

There are being provided 6 new passenger coaches of the interurban type, about 54 ft. long and seating 56 people, which were built by the St. Louis Car Co. They are equipped with especially heavy trucks, the electrical equipment comprising four 100-H. P. motors, one on each axle besides the transformer,

**Replacement of Steam by Electricity.**

One of the most important achievements of modern times is the development of electric traction to such a point that the replacement of the steam locomotive by the electric motor is no longer considered a vague possibility of the distant future, but a matter for active discussion among progressive railway officials.

A change from steam to electricity as a motive power has, as a rule, been seriously considered heretofore only in connection with very frequent suburban service, with the elimination of smoke from long tunnels, or under similar special conditions. All of the cases of steam railroad electrification which have previously been undertaken have been of this character. To this class belong the Long Island Electric Lines and the West Jersey and Seashore R. R. of the Pennsylvania system, the Baltimore tunnel of the B. & O., the suburban lines of the New York Central and the New York, New Haven and Hartford, and the Sarnia tunnel of the Grand Trunk.

In such instances electricity has been adopted as a luxurious addition to an already fairly satisfactory service, and the possible field for such developments is limited to the neighborhood of a comparatively few large cities. All over the country, however, there are numerous cases where, on account of the unsatisfactory character of the best service which the railroads could afford to give with steam locomotives, the local business of the railroads has been almost entirely absorbed by competing

for use on the trolley at a transformer substation at Avon, 19 miles from Rochester. The new electric cars will make the same schedule speed as the present steam trains, but in addition to the eleven fixed stops which the latter now make, will make flag stops every mile. The work on this line is now nearly completed and already two of the cars have been successfully operated over it.

In the case of the Baltimore and Annapolis Short Line, the distance from Baltimore to Annapolis is 28 miles and the trolley voltage is 6,600. There will be nine cars, each equipped with four 100 horse power motors and capable of maintaining a speed of from 50 to 55 miles per hour on a level track. These cars will be operated either singly or in multiple unit trains, as occasion may require, and will be run on hourly or half-hourly headway. Electric power for operating the line will be purchased from one of the central station companies in Baltimore.

Such freight as it may be necessary to handle over both of these lines will be moved, for the present at least, by means of steam locomotives.

Another instance of the growing appreciation of the advantages of electrical operation, even where the handling of freight is an important consideration, is the new Palouse and Colfax line of the Spokane and Inland Empire

at 45,000 volts to eleven transformer substations along the line, where it is reduced to 6,600 volts for use on the trolley. The present equipment consists of 15 passenger cars, each equipped with four 100 horse power motors, which will be operated in three car trains composed of two motor cars and one trailer. There are also in operation six motor driven freight cars, with motors of the same capacity but geared for a slower speed, and six fifty ton freight locomotives with four 150 horse power motors each. The company has recently ordered eight 72-ton freight locomotives of similar design, which are each to be supplied with four 175 H.P. motors. When these are received this road will have a freight equipment exceeding its passenger equipment by one-third, in number of motive power units, and by nearly two-thirds in horse power capacity, and will occupy a unique position among electrically operated railroads.

These instances of steam railroad electrifications under conditions widely different from those heretofore considered necessary to warrant electrical operation are significant of modern tendencies, and, if successful, as they undoubtedly will be, will doubtless be followed widely on similar lines.

**Mechanical Stoker on the Erie.**

The mechanical stoker used on the Erie Railroad has been in operation for a considerable time. It has been applied to a heavy consolidation No. 1627. This engine is simple, with cylinders 22x32 ins. Diameter of driving wheels 62 ins. Steam pressure 200 lbs., and a calculated tractive effort of 49,960 lbs. The adhesive weight of the engine is 176,400 lbs., while its total weight in working order amounts to 200,700 lbs. The heating surface provided by the flues is 3,184 sq. ft. This added to the 174 sq. ft. of heating surface of the fire-box, gives a total of 3,358 sq. ft. The flues are 380 in number, 2 ins. outside diameter, and are each 16 ft. long. The fire-box is 104½ ins. long and 75 ins. wide, giving a grate area of 54 sq. ft. The ratio of grate area to heating surface is as 1 is to 62.2. The tender has a water capacity of 6,800 gallons, 14 tons of coal and weighs, loaded, 137,000 lbs.

The mechanism by which coal is taken from the fuel space in the tender and delivered in the fire-box may be considered to be, as it actually is, two distinct pieces of apparatus. The function of the tender equipment is to convey coal to a hopper on the back boiler head, and the engine equipment consists of the appliances by which the coal in the hopper is introduced into the box and spread upon the fire. The operation of the stoker, as a whole, may be rendered continuous, or

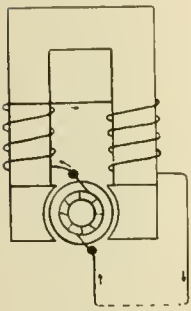

FIG. 10. SERIES WOUND.

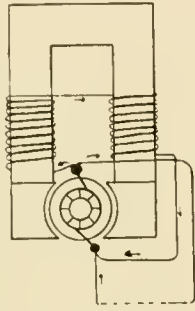

FIG. 11. SHUNT WOUND.

trolley lines. The electrical equipment of such lines in order to better serve the community or to retain or regain traffic in the face of trolley competition, has either not been considered at all or has been considered inadvisable.

Owing to the improved methods available since the perfection of the single phase, alternating current system, this matter is now receiving more favorable consideration and a broad field for steam railroad electrification has been opened up. Already during the past year the Erie Railroad has undertaken the electrification of its Rochester division between Rochester and Mt. Morris, and the former Baltimore and Annapolis Short Line Railroad has contracted for the electrical equipment of its line between Baltimore and Annapolis by means of this system. In neither case was the traffic dense nor the prevention of smoke of any particular importance. The change to electricity is being made primarily to better the service by permitting the operation of single cars or trains of two or more units at one hour headway or less, instead of the previous steam service of four or five trains per day.

In the case of the Erie electrification the distance between Rochester and Mt. Morris is 34 miles. There will be six motor cars, each equipped with four 100 horse power, single phase motors. Standard coaches will be used as trailers when necessary. The line will be operated by an overhead trolley carrying alternating current at 11,000 volts. Power will be secured from Niagara Falls, 90 miles away, at 60,000 volts, and this will be reduced to 11,000 volts

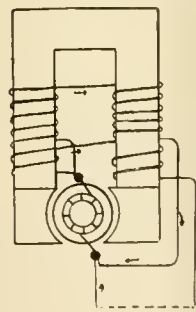

FIG. 12. COMPOUND WOUND.

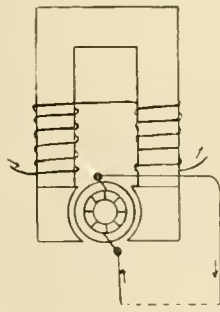

FIG. 13. SEPARATELY EXCITED.

R. R. of Spokane, Washington. A few years ago this line would have been operated by steam locomotives. As actually built, however, both freight and passenger service are operated by means of the single phase electric system.

Beginning at Spokane, where connections are made with the Great Northern, Northern Pacific and Union Pacific systems, this line extends in a general southerly direction, 76 miles to Colfax. From Spring Valley, 39 miles from Spokane, a branch line extends 40 miles to Palouse, making a total of 116 miles. Considerable extensions to both lines are contemplated. At the present time 40 miles are in operation. Power is purchased from the Washington Water Power Co., of Spokane, and transmitted

either or both parts of the mechanism may be stopped at will. Hand firing may be resorted to without any alteration in the stoker mechanism as it is practically cut of the way of the fireman and engineer all the time. This stoker was made

carried on angle iron supports, reaching, in arch form, from the top of the water legs of the tank, and additional support is afforded by attachment to the overhead conveyor tube. There is no connection between the tender equipment and that on

ton rods of which are fitted with Scotch yokes which secure the rotation of the gear and sprocket wheels necessary to drive the mechanism. The engine is bolted to the right upright conveyor tube, and steam and exhaust pipes are carried through the floor of the tender and connect with pipes on the engine by means of Moran flexible joints. The steam for driving the engine is taken from the outside at the top of the dome, and the exhaust connects with the blower pipe and waste steam is discharged up the stack in a manner similar to that of the air pump. The carrying of coal from the tender to the hopper on the boiler head is performed by this little engine and the speed of the conveyor mechanism and the speed of delivery may be regulated according to work the engine is doing at any time. Shutting off the steam supply to the little engine stops the delivery of coal.

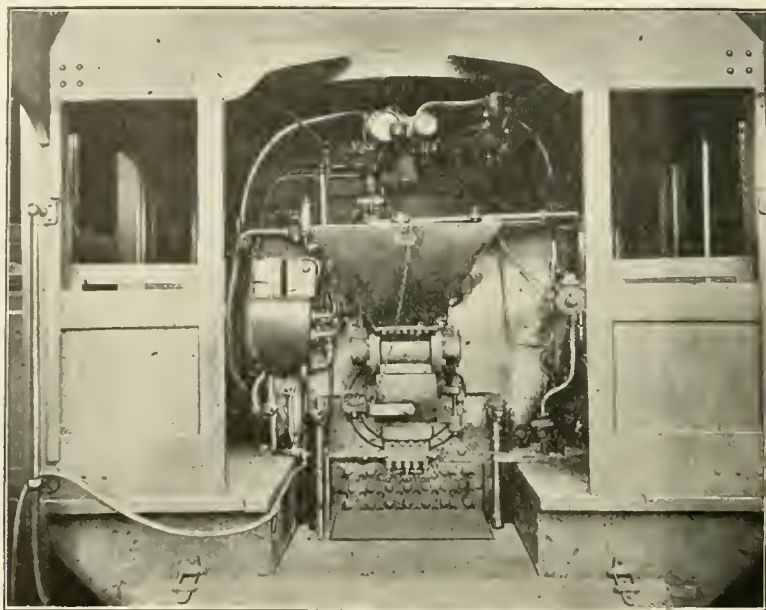

ENGINE WITH HAYDEN MECHANICAL STOKER.

by the N. L. Hayden Manufacturing Company of Columbus, Ohio.

Tracing the coal from tender to fire-box, there is first the receiving grate. This is a heavy casting placed in the floor of the tender close in front of the coal gates. The casting has a series of openings  $4 \times 3\frac{3}{8}$  ins., separated by narrow bridges, and through these openings the coal drops into a conveyor trough, immediately under the receiving grate. In this trough, which extends across the fuel space from water leg to water leg of the tank, are a series of buckets, carried on a pair of endless chains. The conveyor system consists of the bottom trough just referred to, at each end of which are two upright hollow tubes of oblong section, with an overhead tube, corresponding to the conveyor trough in the floor of the tender. The conveyor buckets move along the trough, toward the right, up the hollow tube, at that end, then back along the overhead horizontal tube, and down the left hand hollow tube of the system. The conveyor buckets therefore travel in a rectangle, and elevate coal to a height of about six feet above the receiving grate. When the coal, moved along by the buckets, comes to the center of the overhead tube, it is discharged into a worm conveyor at the same level, which is placed fore and aft, and by means of the worm, the coal slowly travels forward toward the engine, and on reaching the end of the worm conveyor trough, it drops into the hopper which is carried on the back head of the boiler.

The overhead worm conveyor trough is

the engine, so that by uncoupling the small steam pipes and other regular connections between engine and tender, the tender may be readily disconnected from the engine. The worm conveyor trough passes in below the overhanging roof of the cab, and is above and free from the hopper, so that inequalities of motion of engine and tender cannot disturb the con-

The conveyors and little engine thus perform what is probably the greater part of the physical work of the fireman, and as such, the tender equipment might be called a mechanical coal heaver, while the task of substituting for the intelligent work of the fireman in distributing coal to the fire, is performed by the engine equipment, and this latter constitutes the mechanical stoker proper.

The engine equipment consists of a hopper with a feed tube at the bottom by means of which coal passes through the fire door. There is also a set of steam nozzles and a small engine for operating an intermittent steam blast for distributing the coal over the fire. In order to describe this arrangement more minutely,

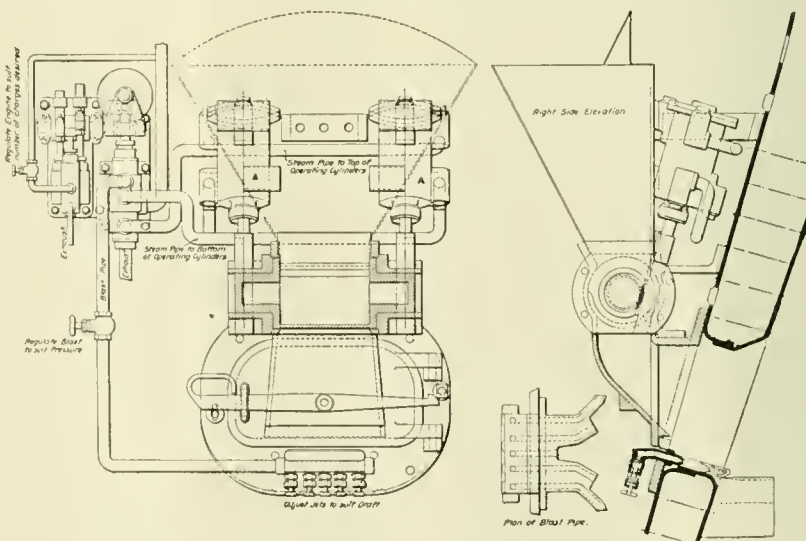

FRONT AND SIDE ELEVATION OF ENGINE EQUIPMENT.

stant delivery of coal from the tender to the engine while the conveyor mechanism is at work.

The motion of the buckets and that of the worm in the longitudinal overhead conveyor is produced by the operation of a small twin engine with cylinders  $5 \times 4$  ins., with  $\frac{3}{4}$  cut-off, the pis-

ton rods of which are fitted with Scotch yokes which secure the rotation of the gear and sprocket wheels necessary to drive the mechanism. The engine is bolted to the right upright conveyor tube, and steam and exhaust pipes are carried through the floor of the tender and connect with pipes on the engine by means of Moran flexible joints. The steam for driving the engine is taken from the outside at the top of the dome, and the exhaust connects with the blower pipe and waste steam is discharged up the stack in a manner similar to that of the air pump. The carrying of coal from the tender to the hopper on the boiler head is performed by this little engine and the speed of the conveyor mechanism and the speed of delivery may be regulated according to work the engine is doing at any time. Shutting off the steam supply to the little engine stops the delivery of coal.



regulated at will. The hopper when full contains about 175 lbs. of fine coal, which is the kind for which the stoker is designed.

Immediately below the hopper is the

heap of coal on the table and in the interval, before the succeeding blast of steam issues forth, the coal quickly feeds down on the table and makes a heap as before.

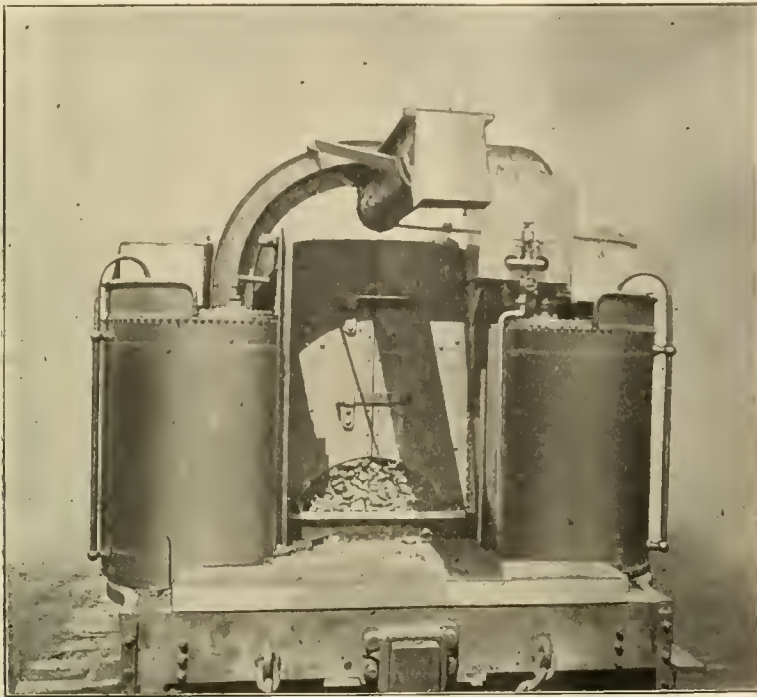

TENDER EQUIPMENT, HAYDEN STOKER.

fire door, modified to suit conditions. The door contains a slightly tapering coal passage or chute, set at an angle of about 45 degrees. The function of this passage, which at its lower end is 6x12 ins., is to permit coal from the hopper outside the engine to be delivered to the inside of the fire-box. The door is not connected with the hopper in any way, and when the slide at the base of the hopper is closed, the fire door can be opened or closed by hand quite readily, as it is not a fixed part of the mechanical stoker. The coal, after it passes through this tapering chute in the door, is delivered on the door flange above the water space and on a flat table 5 ins. wide by 24 ins. long, which is bolted to the inside back sheet of the fire-box. The fine coal thus delivered remains heaped on the table and up to the mouth of the tapering chute in the door. The size of this loose heap may be altered from time to time by the adjustment of the movable plate on the outside and upper part of the tapering chute. Reference to this was made above.

Thus far the coal has been traced from the tender to the inside of the fire-box. The latter part of this journey, that from hopper to what may be called the operating table, has been accomplished by the action of gravity; the final distribution of coal over the grate is accomplished by means of an intermittent steam blast, which is driven out flat over the table from five radially directed nozzles. The blast undermines and blows away the

The mechanism by which the intermittent blast for automatic firing is produced consists of a smaller size of twin engine than that used on the tender, but similar in design. This engine has cylinders  $1\frac{1}{2}$ x

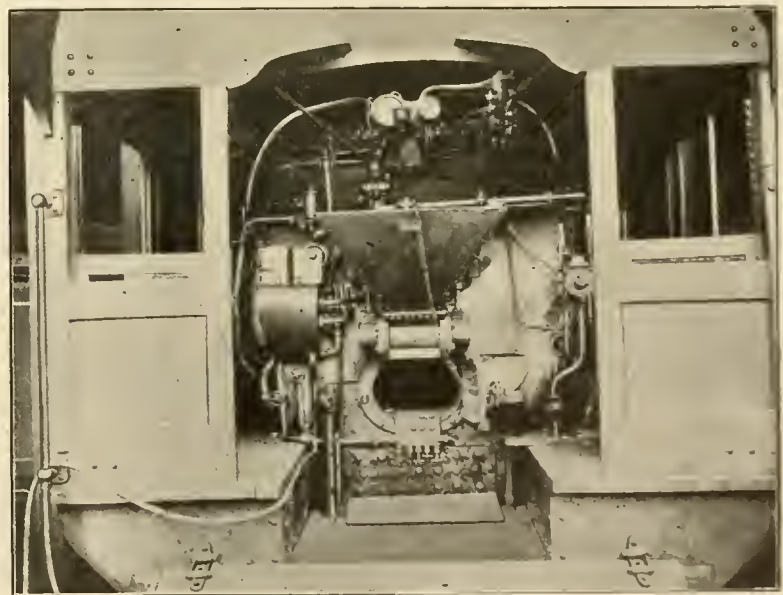

DOOR OPEN, READY FOR HAND FIRING.

$1\frac{1}{2}$  ins. and the rotation of a small shaft which it accomplishes thereby turns a small gear wheel placed in an upright position which carries on its face a striking pin with a beveled end.

The striking pin is attached to the revolving striking wheel and is adjustable

in a guide-way. This striking pin when revolving strikes the beveled end of the bell crank lever and rocks it on its fulcrum at its center. This bell crank lever, when rocked, lifts a small auxiliary valve that is seated in the top cap of the blast valve. This auxiliary valve has a stem on it that extends downward through the piston valve, but the piston valve works freely on this stem and is not attached to it. The idea of extending this stem into the piston valve is to keep the steam pressure off the bottom of the auxiliary valve so that the auxiliary valve is practically a balanced valve when open. The depression of this pin acts upon a lever which rests at one end on a stiff coil spring. The other end of the lever is attached to the stem of what is practically an inside admission piston valve. The interior cavity of this piston valve is, when in use, always filled with steam direct from the boiler. The upper end of this piston valve has a greater area than its lower end and as the valve is vertical it is normally held by steam pressure at the upper extremity of its stroke. In this position the valve is shut, for though the internal cavity is constantly full of live steam, it cannot escape.

The revolution of the upright gear wheel carries the striking pin around so that in passing over the upturned bevel end of the lever pin, it is depressed, thus depressing the lever, and forcing down the valve stem. The piston valve thus pushed down travels far enough to cause its internal cavity to communicate with

the blast pipe leading to the nozzles which play over the table in the fire-box. The opening of this valve takes place only while the bevel faces of the two pins are in contact and as soon as the striking pin on the rotating wheel has passed beyond the lever pin, the internal

pressure of the piston valve and the action of the coil spring at the end of the lever promptly carry the piston valve up, and so shuts off the flow of steam to the nozzles.

The travel of the piston valve, and the consequent width of opening by which steam enters the blast pipe, is determined by the adjustment of the striking pin on the small rotating wheel. If one may so say, this regulates the size of the mouthful of steam which gets into the blast pipe. The frequency with which these blasts are delivered depends upon the speed with which the little engine is run, and the pressure of the steam depends upon the amount of opening of the hand valve, governing the flow of steam to the little piston valve.

The form of the casting from which the jets of steam issue is that of a hollow angle. It lies flat down on the lower lip of the fire door. It is practically out of the way all the time, and does not interfere with hand firing. A hand valve below each of the fire nozzles makes it possible to restrict the opening or shut off any particular nozzle, at any time. The intermittent blast passing down the pipe from the piston valve naturally subdivides itself and issues forth from the nozzles which are each  $\frac{3}{4} \times \frac{1}{8}$  in. The heap of coal lying on the table is thus blown off and distributed over the grate. The nozzles are divergent, the outer two blow coal off the table toward the two back corners of the fire-box; the next two,

man to see what is going on in the furnace.

The process of testing this stoker has progressed so far on the Erie that there is no longer any doubt as to the ability of the stoker to maintain steam on the engine, working over a hilly division and pulling heavy freight trains. The stoker

dent Roosevelt, also Earl Grey, Governor-General of Canada, and many others. The United Engineering Society, a holding corporation, took possession of the building on behalf of the Engineering Societies which will have this as their headquarters. The building, described elsewhere in our col-

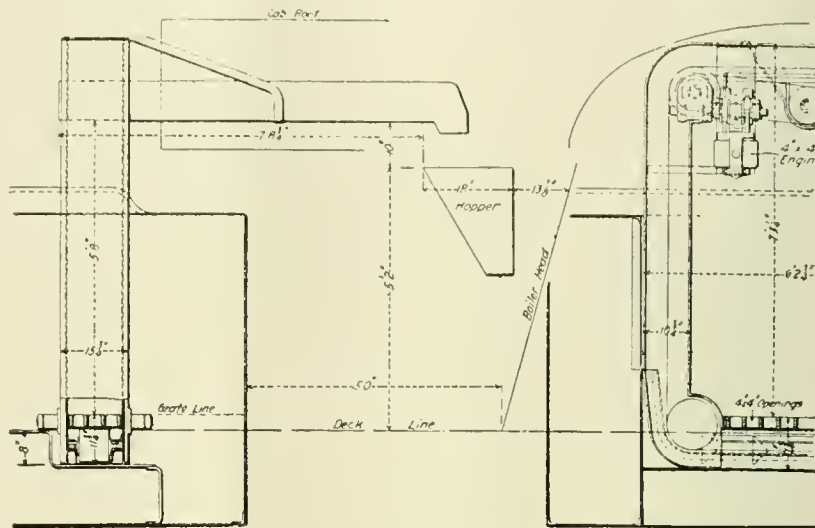

SKELETON SIDE AND END VIEW OF STOKER.

has done this in bad weather and in good, and has kept up steam against the effects of a leak which would have in all probability taxed hand firing to the point of failure. We expect to be able in the near future to give our readers the results of a test to determine the efficiency of the stoker in the matter of coal and water

columns, was the gift of Mr. Andrew Carnegie, and is situated on West 39th street, New York.

The dedication ceremony was presided over by Mr. Charles W. Hunt, past president of the American Society of Mechanical Engineers. The principal speaker was President Hadley of Yale University. Forty-three colleges and technical schools and many scientific societies were represented in the gathering.

A reception was held in the evening in the main auditorium of the building, at which the receiving party consisted of the presidents of the three founder societies, the American Society of Mechanical Engineers, the American Institute of Electrical Engineers and the American Institute of Mining Engineers, and of the United Engineering Society with their friends. Later in the evening, in the respective rooms of the societies, the officers and councils of the three founder societies received the members and guests, and the entire building was opened for inspection.

**Activity on the N. P.**

Advices from Culdesac state that the Northern Pacific Railroad has begun laying steel on the Culdesac-Grangeville extension. The track will be laid from the former town to Canyon City, a distance of nine miles. From Canyon City the construction crews will still continue the work of completing several tunnels and fills. Rails, ties and bridge timber are going into Culdesac daily, so that the determination of the Northern Pacific to rush the road to completion is being carried out.

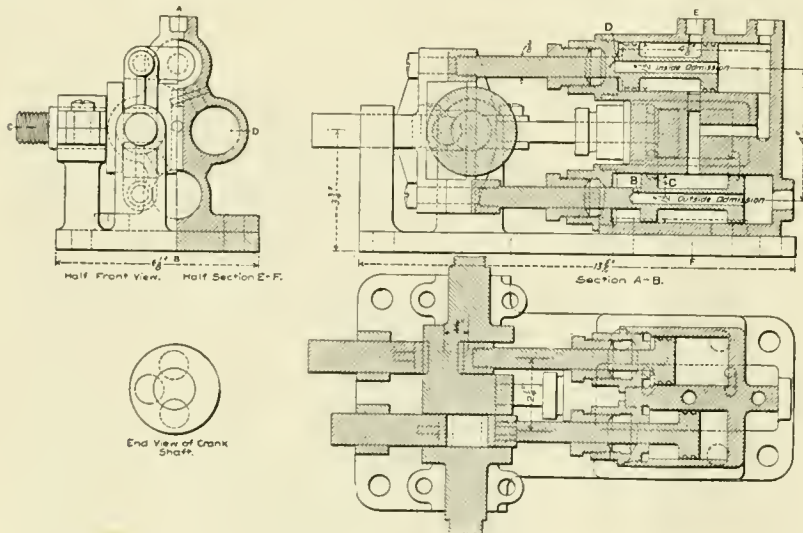

SECTION OF ENGINE FOR STEAM BLAST OF STOKER.

slightly less divergent, blow coal in the direction of the forward corners, and the center one is directed straight ahead. The effect of this distribution, when all the adjustments have been made, is to secure approximately an even spreading or sprinkling of coal over the grate surface. This automatic firing is constantly maintained at short regular intervals, small amounts of coal are used at each discharge, and the fire door is not opened. A peep hole in the door enables the fire-

consumption with heavy trains as compared with average performances with hand firing.

**Dedication of Engineers' Building.**

The dedication of the Engineering Societies' Building in New York took place about the middle of April. A distinguished company of American and foreign men of science were present and letters and telegrams of congratulation were read from Presi-

# Items of Personal Interest

Mr. R. C. Thurston has been appointed supervisor of electric service for the Erie at Avon, N. Y.

Mr. C. D. Whitney has been elected president of the Toledo, Wabash & St. Louis, with headquarters at Toledo, O.

Mr. Jeff Cornish has been appointed road foreman of equipment on the Rock Island Railway at Forth Worth, Tex.

Mr. James L. Caldwell has been appointed assistant road foreman of engines on the Pittsburgh & Lake Erie Railroad.

Mr. William L. Cross has been appointed assistant road foreman of engines of the West Jersey & Seashore Railway.

Mr. S. W. Lee has been appointed consulting engineer of the Missouri & North Arkansas, with office at St. Louis, Mo.

Mr. J. D. Crawley has been appointed master mechanic of the Georgia, Florida & Alabama, with office at Bainbridge, Ga.

Mr. Irving Seiders has been appointed foreman of engines on the main line of the Philadelphia & Reading Railroad.

Mr. Harry Wolhaker has been appointed roundhouse foreman of the West Jersey & Seashore Railway at Atlantic City.

Mr. H. M. Thurston has been appointed road foreman of engines of the second division of the Seaboard Air Line Railway.

Mr. W. J. Haynen has been appointed master mechanic of the Mississippi Central, vice Mr. R. M. Boldridge, resigned.

Mr. Thos. Cain has been appointed general foreman of the shops of the St. Louis, San Francisco & Texas Railway at Sherman, Texas.

Mr. W. J. Haynen has been appointed master mechanic of the Mississippi Central, vice Mr. R. M. Boldridge, resigned.

Mr. J. Schumaker has been appointed master mechanic of the Missouri Pacific at Ferriday, La., vice Mr. R. W. Ruffner, resigned.

Mr. John Parker has been appointed supervisor of signals of the Buffalo division of the New York Central at East Buffalo, N. Y.

Mr. C. L. Ruffin has been appointed division engineer on the South & Western, at Clinchport, Va., vice Mr. A. W. Jones, promoted.

Mr. F. K. Tutt has been appointed master mechanic of the Missouri Pacific at Ossawatimic, vice Mr. W. B. Gaskins, resigned.

Mr. Duncan Robertson has been appointed foreman of the Texas Pacific shops at Marshall, Texas, vice Mr. C. A. Peaker, resigned.

Mr. L. M. Sorrell has been appointed road foreman of engines on the Baltimore & Ohio Railway, with headquarters at Parkersburg.

Mr. T. F. Carbery has been appointed master mechanic on the Missouri Pacific at St. Louis, Mo., vice Mr. M. J. McGraw, transferred.

Mr. Robert Stewart, of the Tehuantepec National, has been promoted to be roundhouse foreman at Rincon Antonio on the same road.

Mr. Harry Koehler has been appointed traveling engineer on the Mexican Central railroad, with headquarters at San Luis Potosi.

Mr. O. A. Cherry has been appointed assistant chief motive power clerk of the Pennsylvania railroad, with headquarters at Altoona, Pa.

Mr. G. M. Ellsworth has been appointed chief motive power clerk of the Pennsylvania railroad, with headquarters at Altoona, Pa.

Mr. C. M. Taylor has been appointed assistant superintendent of motive power of the Chicago, Rock Island & Pacific at Shawnee, Okla.

Mr. H. D. Kinsella has been appointed road foreman of engines on the Pere Marquette Railway, with headquarters at Detroit, Mich.

Mr. L. M. Perkins has been appointed division engineer of the Northern Pacific at St. Paul, in charge of the lines east of Staples.

Mr. P. L. Rhodes has been appointed sales manager of the Homestead Valve Manufacturing Co., at Pittsburgh, Pa., vice Mr. C. B. Ault, resigned.

Mr. F. H. McGuigan, fourth vice-president of the Grand Trunk Railway, has resigned to enter the Great Northern Railway (U. S.) service.

Mr. H. G. Reid has been appointed locomotive foreman of the Canadian Pacific Railway, at Chapleau, Ont., vice Mr. H. W. Fletcher, resigned.

Mr. John N. Davis has been appointed master carpenter of the Pennsylvania Railroad at Tyrone, Pa., vice Mr. H. S. Wyman, deceased.

Mr. R. G. Long has been appointed master mechanic of the Missouri Pacific system at Fort Scott, Kan., vice Mr. W. C. Walsh, resigned.

Mr. G. W. Mudd, formerly master mechanic on the Wabash, has been appointed master mechanic of the Denver & Rio Grande at Alamosa, Colo.

Mr. J. J. Curtis has been appointed master mechanic of the Chicago Union Transfer, with office at Clearing, Ill., vice Mr. D. Anderson, resigned.

Mr. W. L. Harrison has been appointed assistant superintendent of motive power of the Chicago, Rock Island & Pacific, at Cedar Rapids, Iowa.

Mr. M. F. Burke has been appointed general foreman of shops of the Toledo & Ohio Central at West Columbus, O., vice Mr. W. R. Davis, promoted.

Mr. F. M. Moore has been appointed assistant road foreman of engines over the western and middle sections of the P. & E. division of the Pennsylvania.

Mr. J. B. Kilpatrick has been appointed assistant superintendent of motive power of the Chicago, Rock Island & Pacific, with office at Chicago, Ill.

Mr. W. C. Taylor has been appointed acting division engineer on the Northern Pacific, in charge of the lines east of Mandan, with office at St. Paul, Minn.

Mr. F. E. Patton, formerly with the Mobile & Ohio Railway, has been appointed road foreman of engines of the Southern Railway in Mississippi.

Mr. F. W. Williams has been appointed assistant superintendent of motive power on the Chicago, Rock Island & Pacific at Fort Worth, Tex.

Mr. Tabor Hamilton has been appointed master mechanic of the Cumberland Valley, with office at Chambersburg, Pa., vice Mr. J. B. Diven, resigned.

Mr. W. Kennedy has resigned as master mechanic on the Grand Trunk at Toronto, Ont., to accept a position with the Great Northern Railway of Canada.

Mr. L. A. Larsen, formerly chief clerk to the mechanical superintendent of the Northern Pacific, has entered the service of the American Locomotive Co.

Mr. H. P. Waldon, formerly assistant purchasing agent, has been appointed purchasing agent of the Pullman Company, vice Mr. W. A. Hughes, deceased.

Mr. Eugene Hartenstein, formerly general road foreman of engines, has been appointed road foreman of engines on the Toledo & Ohio Central Railway.

Mr. M. H. Strauss has been appointed road foreman of engines on the Pennsylvania Division of the New York Central, vice Mr. C. P. Diehr, promoted.

Mr. R. F. Jaynes, general shop foreman, has been appointed to the new office of master mechanic on the Lehigh & Hudson River, with headquarters at Warwick, N. Y.

Mr. Wm. Winkie has been appointed night roundhouse foreman at Cedar Rapids on the Burlington, Cedar Rapids & Northern, vice Mr. W. N. Foster, transferred.

Mr. W. E. Hooton has been appointed chief clerk to the superintendent of motive power and rolling stock of the Santa Fe Central, with office at Estancia, N. M.

Mr. J. R. Donnelly has been appointed master mechanic of the Grand Trunk Railway, Ottawa Division, with office at Ottawa, Ont., vice Mr. J. Ogilvie, resigned.

Mr. Thomas Tait, chairman of the Victoria Railway Commission of Australia, is soon to take an extended holiday in America. He expects to reach Montreal in July.

Mr. R. M. Galbraith has been appointed superintendent of machinery of the Kansas City Southern with office at Pittsburg, Kan., vice F. Mertsheimer, resigned.

Mr. George Cooper has been appointed road foreman of engines on the Grand Trunk Railway, Middle and Southern Divisions, with headquarters at Sarnia Tunnel, Ont.

Mr. A. E. Clift, formerly on the Freeport division, has been appointed superintendent of the St. Louis division of the Illinois Central, with headquarters at Carbondale, Pa.

Mr. J. J. Flynn, formerly general foreman of the shops of the Louisville & Nashville at Mobile, Ala., has been appointed master mechanic on the same road at Nashville, Tenn.

Mr. E. Fitzgerald, formerly assistant to the general purchasing agent, has been appointed assistant general purchasing agent of the Canadian Pacific Railway at Montreal, Can.

Mr. M. M. Hayes has been appointed supervisor of signals of the Western division of the New York Central, with office at Rochester, N. Y., vice Mr. J. J. Cozzens, promoted.

Mr. G. W. Goethals, who was recently appointed chief engineer of the Panama Canal, has been elected presi-

dent of the Panama Railroad, vice Mr. T. P. Shonts, resigned.

Mr. E. W. Knapp has been appointed master mechanic of the International Mexican Railroad at Monclova, Mexico, vice Mr. G. A. Oliver, resigned to engage in mining business.

Mr. M. J. McGraw, formerly master mechanic at St. Louis, Mo., has been transferred as master mechanic on the Missouri Pacific to Sedalia, Mo., vice Mr. S. M. Dolan, resigned.

Mr. H. Putnam, formerly assistant purchasing agent of the Mexican Central, has been appointed superintendent of car service on the same road, with office at the City of Mexico.

Mr. P. Z. Zany has been appointed master mechanic of the Worcester division of the New York, New Haven & Hartford at Providence, R. I., vice Mr. G. Donahue, promoted.

Mr. J. B. Diven, formerly master mechanic of the Cumberland Valley, has been appointed assistant engineer of motive power of the New Jersey grand division of the Pennsylvania.

Mr. T. J. Tonge has been appointed superintendent of motive power, rolling stock, bridges, buildings and water service of the Santa Fe Central, with office at Estancia, New Mexico.

Mr. W. R. Willis has been appointed Engineer of the Missouri district of the Chicago, Burlington & Quincy Railway, with headquarters at St. Louis, Mo., vice Mr. A. W. Newton, promoted.

Mr. F. C. Link, formerly road foreman of engines of the first and second divisions of the Seaboard Air Line Railway, has been transferred to the first division of the same road.

Mr. W. F. Girten has been appointed general storekeeper of the Central Railroad of New Jersey, with headquarters at Elizabethport, N. J., vice Mr. H. S. Hoskinson, resigned.

Mr. O. E. Maer has been appointed trainmaster of the Forth Worth & Denver City Railway Company, with headquarters at Wichita Falls, Texas, vice Mr. J. H. Riegel, resigned.

Mr. Joseph Warren, formerly general foreman at Whitmore, O., has been transferred to Corning, O., as general foreman of the Toledo & Ohio Central, vice Mr. M. F. Burke, promoted.

Mr. C. L. Ewing, formerly with the St. Louis division of the Illinois Central, has been made general superintendent of the lines north of the Ohio River, with headquarters in Chicago.

Mr. L. S. Oakes has been appointed division engineer of the Idaho and Pasco divisions of the Northern Pacific, with office at Spokane, Wash., vice Mr. T. H. Crosswell, transferred.

Mr. G. W. Snyder, formerly assistant engineer of the Pittsburgh division of the Pennsylvania, has been appointed

principal assistant engineer of the new Western Pennsylvania grand division.

Mr. M. P. Cheney, formerly road foreman of engines at Needles, Cal., has been appointed road foreman of engines of the Los Angeles Division of the Santa Fe at San Bernardino, Cal.

Mr. A. C. Adams, formerly with the Rock Island, has been appointed master mechanic of the Pennsylvania division of the Lehigh Valley, at Sayre, Pa., vice Mr. John McMullen, resigned.

Mr. O. C. Omer has been appointed assistant purchasing agent of the Mexican Central with office at the City of Mexico, vice Mr. H. Putnam, transferred to the car service department.

Mr. John Lynch, formerly traveling engineer, has been appointed master mechanic of the Southwest division of the Chicago Great Western Railway, with headquarters at Des Moines, Ia.

Mr. C. E. Gossett, master mechanic of the St. Louis, Kansas City & Colorado, has had his jurisdiction extended to include the Kansas City Terminal Division with headquarters at Armourdale, Kan.

Mr. J. H. Strubel has been appointed to the newly created position of assistant to the general manager of the Ann Arbor and the Detroit, Toledo & Ironton, with headquarters at Toledo, Ohio.

Mr. George Siemantel, formerly general foreman of the Santa Fe shops at Ottawa, Kan., has been appointed general master mechanic of the Fort Worth & Denver City at Childress, Texas.

Mr. W. N. Foster, until recently night roundhouse foreman on the Burlington, Cedar Rapids & Northern, has been transferred to the Estherville roundhouse as day foreman on the same road.

Mr. J. B. Duxbury, formerly night roundhouse foreman at Estherville, Iowa, on the Burlington, Cedar Rapids & Northern, has been transferred as day roundhouse foreman to Cedar Rapids, Iowa.

Mr. W. R. Davis, formerly general foreman of shops of the Toledo & Ohio Central at West Columbus, Ohio, has been appointed road foreman of engines at Columbus, vice Mr. E. Hartenstein, resigned.

Mr. A. B. Todd, formerly master mechanic of the Los Angeles division of the Santa Fe Coast Lines, has been transferred to the valley division at Richmond, Cal., vice Mr. E. H. Harlow, transferred.

Mr. N. L. Moon, formerly trainmaster of the Delaware & Hudson at Carbondale, Pa., has been appointed superintendent of the Wyoming division of the Lehigh Valley, with office at Wilkes-Barre, Pa.

Mr. W. R. Hudson, formerly superintendent of the first division of the Seaboard Air Line, has been appointed superintendent of terminals of the Southern Railway, with headquarters at Salisbury, N. C.

Mr. Mullinix has been appointed superintendent of motive power of the Chicago, Rock Island & Pacific Railway for the Southwest District, with office at Topeka, Kan., vice Mr. W. F. Tollerton, promoted.

Mr. R. H. Rutherford, master mechanic of the Mexican Central at Torreon, Mexico, has been appointed master mechanic of the Aguascalientes division of the road, with headquarters at Aguascalientes, Mexico.

Mr. A. B. Cuthbert, formerly assistant engineer of the Middle division of the Pennsylvania, has been appointed principal assistant engineer of the Eastern Pennsylvania grand division, vice Mr. A. J. Whitney, transferred.

Mr. W. J. Tollerton, formerly superintendent of motive power at Topeka, Kan., has been appointed to the new office of assistant general superintendent of motive power on the Chicago, Rock Island & Pacific Railway.

Mr. L. J. Miller has been promoted from division foreman of the Missouri Pacific to master mechanic of the Northern Kansas and Omaha divisions, with the exception of the Kansas City Northwestern at Atchison, Kan.

Mr. Elisha Lee, formerly assistant engineer of the Philadelphia terminal division of the Pennsylvania, has been appointed principal assistant engineer of the Philadelphia, Baltimore & Washington, vice Mr. C. S. Krick, transferred.

Mr. W. T. Rupert has taken a trip to Manchuria in the interest of the American Locomotive Company, where he will be engaged in the erecting and placing in service one hundred locomotives which have been sent there this year.

Mr. D. M. Perine, formerly superintendent of motive power of the Philadelphia & Erie and the Northern Central, has been appointed superintendent of motive power of the Western Pennsylvania grand division of the Pennsylvania.

Mr. D. M. Wallace, formerly master mechanic of the Baltimore and West Philadelphia shops, has been appointed superintendent of motive power of the Philadelphia & Erie and the Northern Central, vice Mr. D. M. Perine, transferred.

Mr. George Donahue, formerly division master mechanic of the New York, New Haven & Hartford at Providence, R. I., has been appointed Master Car Builder of that road at Readville, Mass., vice Mr. T. D. Simpson, resigned.

Mr. C. P. Diehr, formerly road foreman of engines on the Pennsylvania division of the New York Central, has been appointed general master mechanic of the Pennsylvania Division of the New York Central, with headquarters at Avis, Pa.

Mr. Allan M'Duff, formerly general foreman of the Burlington, Cedar Rapids & Northern and Rock Island shops at Cedar Rapids, Ia., has resigned to devote all his time to the duties of county supervisor, a position to which he has just been appointed.

Mr. W. G. Wallace has been appointed to the new office of superintendent of motive power of Ann Arbor & Detroit, and the Toledo & Ironton, with office at Jackson, Ohio. The office of master mechanic of the Ann Arbor & Detroit has been abolished.

Mr. W. W. Hoit, who for a number of years has been general yardmaster of the New York Central at West Albany, has resigned, to become connected with the Quincy, Manchester, Sargent Company, with headquarters at their New York office, in the West Street Building.

Mr. Robert C. Shaal, formerly with the General Storage Battery Company of New York, has accepted the position of sales engineer of the Bliss Electric Car Lighting Company, as assistant to the vice-president, Col. Jno. T. Dickinson, with headquarters at the company's New York office, Night and Day Bank Building, Fifth Avenue and 44th St.

Mr. W. F. Gibbons of London, locomotive superintendent of the railroads in Argentine, South America, is in Pittsburgh giving particular attention to the water softening plants that have been established during the last few years at the McKees Rocks shops of the Pittsburgh & Lake Erie. The Kennicot water softening system has been used for a number of years with most satisfactory results on the Pittsburgh & Lake Erie Railroad.

Mr. E. K. Gillette, Cincinnati manager of the Babcock & Wilcox Boiler Company, in conjunction with Mr. J. A. Brett, Cincinnati manager of the Westinghouse Electric & Mfg. Company, and Mr. Arthur Brown, Cincinnati manager of the Westinghouse Machine Company, recently visited the Fort Wayne & Wabash Valley Traction Company's power plant as a compliment to Mr. Thos. Elliott, consulting engineer, of Cincinnati, who designed the plant.

Mr. William McNab, assistant engineer of the Grand Trunk, was recently elected vice-president of the American Railway Engineering and Maintenance of Way Association, which means that in due course, according to practice, he will be made president of that body. It is the first time that a Canadian has been elected to this office. Mr. Mc-



Copy 69-C FREE

Here is a complete and interesting story of graphite and its development as a lubricant. You can not get in any other book of equal size so much information of REAL value. The experience of practical men and the experiments of scientific authorities are both given in this TENTH EDITION OF

## "Graphite as a Lubricant"

making it valuable to men of practice and students of theory.

Lubrication in almost every kind of machinery is treated of. "Kinks" and "short-cut" methods discovered and used by resourceful engineers are included.

You should get this book now. Write for FREE copy 69-C.

JOSEPH DIXON  
CRUCIBLE CO.  
Jersey City, N. J.

Nab recently delivered a very interesting and instructive lecture before the Nomads' Club in Montreal on the principles and practice of locating a great railway line.

Mr. J. D. Stewart, general superintendent of the Boston & Albany, at Boston, Mass., has retired from railroad service to become president of a Boston Manufacturing Co. The business in which Mr. Stewart will engage concerns what is said to be a process for treating copper which will increase its tenacity, its strength and its wearing qualities. Copper so treated will be used in railway supplies. Mr. Stewart has had a long and varied railroad career, having begun in the train dispatcher's office on the Pennsylvania when he was thirteen years old.

A largely-attended "sociable" was held at Battersea Town Hall, England, last month, in honor of Mr. Thomas Atkinson, the "Father of the Amalgamated Society of Engineers." Mr. Atkinson has been a member of trades unions for seventy-five years. He is now ninety-six years of age, and was an apprentice in George Stephenson's shops when the famous "Rocket" was constructed. It will be remembered that it was the success of this pioneer engine, the "Rocket," against three other competitors, in the Rainhill trial, that placed Stephenson's locomotives in the front rank for many years. The "Rocket" is now in the South Kensington Museum, London.

Mr. H. S. Hoskinson, formerly general storekeeper of the Central Railroad of New Jersey, has recently become connected with the Dressel Railway Lamp Company of New York. Mr. Hoskinson has been for a number of years in railway service, having served his apprenticeship in the Pennsylvania shops at Renovo, Pa. Shortly after the completion of his apprenticeship he was given the position of inspector of piece-work on the same road. Later on he was appointed assistant master mechanic on the Camden & Atlantic Railway, before its absorption by the West Jersey & Seashore. He subsequently became storekeeper of the Amboy division of the Pennsylvania Railroad, which position he held for a number of years, and until he was offered and accepted the position of general storekeeper of the Chicago & Alton at Bloomington, Ill. Shortly after the formation of the American Locomotive Co., Mr. Hoskinson became storekeeper of the Pittsburgh plant of that company, and for the past five years he has been the general storekeeper of the Central Railroad of New Jersey at Elizabethport, N. J. The increasing business of the Dressel Railway Lamp Works has caused that company to look about for able and energetic men and

Mr. Hoskinson's services have been secured by that company. His many friends will be pleased to hear of his advancement and continued prosperity. His intimate acquaintance with all the details of railroad work will make him a valuable acquisition on the staff of the lamp company.

The International Railway Master Boiler Makers' and the Master Steam Boiler Makers' Associations will hold their joint session in Cleveland, Ohio, May 21st, 1907. All boiler foremen and assistant foremen, and others who are actively interested in boiler designing, construction and maintenance are cordially invited to participate in the discussions of this meeting. The Hollenden Hotel has been chosen as official headquarters, with convention hall in the hotel. A splendid programme of entertainment has been arranged for the ladies and friends. It is expected that at least 500 members will attend this meeting, and that a permanent consolidation of the two organizations will be effected at that time.

Mr. J. T. Goodwin, of the American Locomotive Works, Richmond, Va., is secretary of the International Railway Master Boiler Makers' Association, and Mr. George M. Clark, of Sharkey & Peck, Chicago, is secretary of the Master Steam Boiler Makers' Association. The officers of the International Railway Master Boiler Makers' Association will preside at the Cleveland meeting. Much credit is due to Mr. J. T. Goodwin, who was president of the Railway Boiler Makers' organization last year, for bringing these two bodies together. Their objects and purposes are practically the same, and the union will probably result in a more influential organization.

#### Rotary Snow Plow.

A pamphlet recently issued by the American Locomotive Company illustrates and describes the Rotary Snow Plow built by that company. The first part of the pamphlet contains a brief account of the work done by the Rotary in fighting the snow on various railroads, with illustrations of the Rotary in operation. Then follows a description of the plow, giving the particular features of the design. The last part of the pamphlet contains a set of rules for the guidance of those operating the Rotary, based on experience gained during the past years in handling the plow. The pamphlet may be obtained by direct application to the company.

The Standard Coupler Company announce the removal of their New York offices from 160 Broadway to the sixteenth floor of the United States Express Building, No. 2 Rector Street (rear of Trinity Church); also the removal of its Chicago offices from the Monadnock Block to the Fisher Building.

# GOLD Car Heating and Lighting Co.

Manufacturers of

**ELECTRIC,  
STEAM AND  
HOT WATER  
APPARATUS  
FOR RAILWAY CARS**

**EDISON  
STORAGE  
BATTERY  
FOR RAILWAY CAR  
LIGHTING**

Largest Manufacturers in the World  
of Car Heating Apparatus

Catalogues and Circulars  
cheerfully furnished

Main Office, Whitehall Building  
17 BATTERY PLACE  
NEW YORK

**Valve Setting Machine.**

There are a number of very interesting things which one may see when walking through the Erie Railroad shops at Susquehanna, Pa., and among them is a neat little valve setting machine, which has been got up by Mr. H. H. Harrington, the master mechanic at that point. The machine is compact and strong and does its work well.

It is operated by an ordinary air motor, and it can be connected with the rollers which move the driving wheels, by slipping the hollow hub of its little toothed driving wheel over the square end of the roller shaft. This

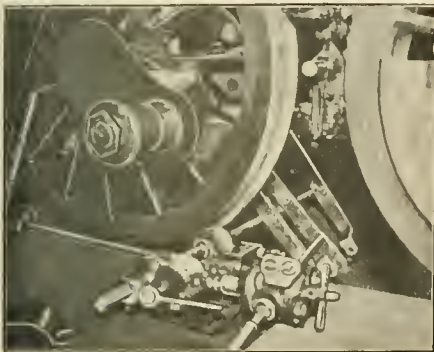

AIR OPERATED VALVE SETTER.

roller shaft carries two driving rollers with corrugated faces, while the other two or idle rollers are plain. The air motor is attached to the valve setting machine in the usual way.

The valve setting machine consists briefly of a rectangular frame, in which are bevel gear wheels. The air motor revolves a shaft with a small bevel gear wheel on it. A shaft at right angles to this carries two bevel gears, one of which only can engage with the air driven bevel at a time. A small lever shifts first one of these and then the other into or out of contact with the air driven bevel wheel, and so reverses the motion of the right angle shaft. On this shaft a small pinion gears with the hollow gear wheel, which is on the driving roller shaft. The operation of the small hand lever at the side determines the direction of rotation which the driving roller shaft receives, and it also throws both bevels out of gear and so instantly stops the motion of the machine and the engine wheels, wherever desired, without stopping the air motor.

The whole arrangement of gears reminds one of the transmission mechanism of an automobile, but the valve setting machine takes up very little room, and as a sailor would say answers the helm quickly and positively. The little air operated machine does the work cut out for it to the satisfaction of everyone, and the squad of "pinchers" which

was formerly required as part of what might be called the "valve setting company" has been turned loose in the shop and are utilized for other purposes, while the machine effects a saving in time, money and muscle.

**No More Brain Fag.**

If you want a handy time and cost computer we know where there is one to be had. It is a very useful thing if you want to check up the time required for such shop operations as boring, turning, or facing an article on a boring or turning mill or a lathe, and if you want to get the cost after you know the time, the computer will give it to you. You don't have to make any calculations, or to run over anybody's figures. All you do is to set three little discs and the trick is done. It is one of the Cox computers, similar to those which were issued by RAILWAY AND LOCOMOTIVE ENGINEERING some years ago, and which became immensely popular.

The computer is made of cardboard and is covered in leather and when folded up it measures 4½x6 ins. There are three little cards turning on a pivot, two of them are sectors and one is a circle, and by setting these as directed on the margin you can at once get the time required for turning or boring and the cost of the same. You can also get the time required for facing with the cost. You can ascertain the suitable cutting speed and feed for a tool when the dimensions of the work are known and the time required has

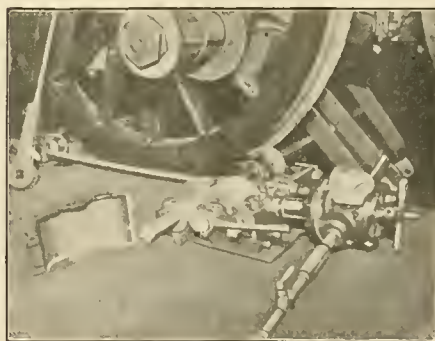

VALVE SETTING MACHINE ON THE ERIE.

been determined. In every case you can get the cost when the computer has given you the time. The computer gives you all these things and incidentally throws in a feeling of satisfaction while reducing the wear and tear on your organ of thought.

If you want a computer to make you wise you can get one by following the directions given below. Remember that to find the time by this computer hardly costs you a thought, and you can get the cost in no time. It gives you the time for any operation without taking up much of yours, and though

# Patents.

GEO. P. WHITTLESEY

McGILL BUILDING WASHINGTON, D. C.

Terms Reasonable Pamphlet Sent

## Ball's Official R.R. Standard Watches

16 AND 18 SIZE

17 and 21 Ruby Jewels, Sapphire Pallets

Ball's Improved Safety Double Roller



Are without question the finest watches that American talent and skilled labor can produce, and they are giving such universal satisfaction that we have no hesitancy in claiming that they are the best and safest railroad watch on the market. Tests severe and numerous have proven this fact to the most critical

users in all sections of the country, to which thousands of good Railroad and Brotherhood men are ready to certify.

We have an authorized agent in nearly every railroad center. Call on him for information and facts. Write us for descriptive matter.

**The Webb C. Ball Watch Co.**

Watch Manufacturers  
Ball Building, Cleveland, Ohio, U. S. A.

## RUBEROID ROOFING

FOR

CARS SHOPS  
CABS ROUND HOUSES

Contains no tar. Will not melt, rot, crack or corrode.

Not affected by extremes of temperature. Highly fire resisting.

Spark-Proof Cinder-Proof  
Gas-Proof Weather-Proof

Write for samples and prices.

THE STANDARD PAINT CO.

100 William St., New York.

Boston, Chicago, St. Louis, Kansas City, Philadelphia, Atlanta.

it gives you the cost it does not cost you anything. The way to become possessed of a computer is to write to the Bullard Machine Tool Company of Bridgeport, Conn., and ask for the kind mentioned in this, the May issue, of RAILWAY AND LOCOMOTIVE ENGINEERING. The request for the time and cost computer will not be costly, though it will certainly be timely.

#### Electric Hoist.

The type of hoist shown in our illustration is a new design. It has a maximum lifting capacity of one-half ton at a lifting speed of 15 ft. per minute. The motor frame supports the load and the entire hoist mechanism, and is made

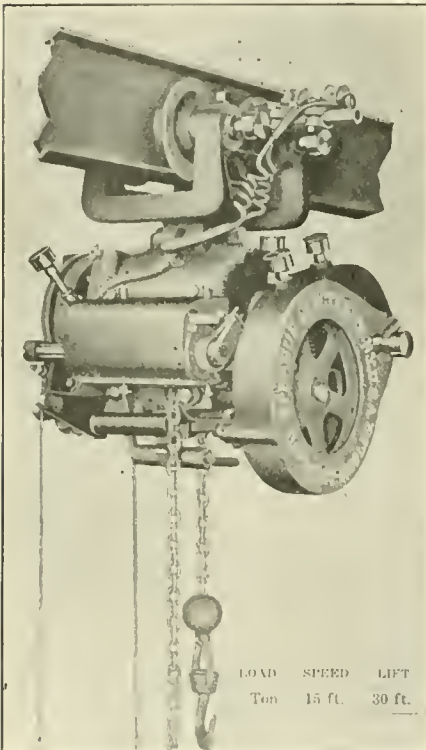

HOIST FOR RAILROAD SHOPS.

of cast steel with an ample factor of safety. The motor itself is entirely enclosed, and it is lubricated by grease fed by compression grease cups.

Grease lubrication has the advantage of being clean and not causing any drip on the floor. There is no danger of it getting on the armature or commutator, and the grease cups being prominent, so to speak, invite attention.

Two gear reductions are interposed between the motor and the pocket wheels, cast iron spur gears with cut teeth being used, the pinions being made of machine steel. The gearing is enclosed in a cast iron box open in the centre. The pocket wheel is made of cast iron, but, of course, is not in tension, and the chain and hook are made of tested stock, the chain being tested after forging. An automatic high

limit switch of the lever type is attached to the hoist.

This type, which the makers, the Sprague Electric Company, of New York, call the S-7 hoist, is compact, the distance from the inside of hook at top of lift to centre of suspension bolt being 25½ ins., and from inside of hook to bottom of I-beam runway, when supplied with plain (Style A) carriage, is 28¾ ins. These hoists are supplied with single speed controllers and plain, trolley carriages.

#### Steamboats and Flying Machines.

The International Maritime Exposition, which will be held in Bordeaux, France, from May to November next, will be to celebrate a century of steam navigation. It will be under the auspices of the League Maritime Francaise, and is likely to be a very pretentious affair. The exhibition will be under the official patronage and aid of the French government, of the Department of the Gironde, the city of Bordeaux, the Chamber of Commerce, and the Philomathic Society. It is open to citizens of all countries, and will receive exhibits of all industrial, agricultural or artistic products pertaining to maritime affairs. Sections will be devoted to ocean geography, aerial navigation and motor boats. It is the intention to include in the programme congresses, competitions and lectures on subjects concerning maritime affairs.

The H. K. Porter Company of Pittsburgh, Pa., builders of light locomotives, have now in preparation a catalogue illustrating and describing the locomotives which they turn out. The catalogue to which we referred in our April issue will be superseded by the new one which will shortly be out. The new catalogue will of course be up to date in every way and will show the heavier and more powerful types not included in the present one. Due notice of the new catalogue will be given and those who desire the latest information on the subject can apply to the company. It may be mentioned the offices of this company are now on the 12th floor of the Union Bank Building, Pittsburgh, Pa.

#### For and Against Fast Trains.

A few years ago American newspapers were vying with each other in urging upon railroad managers demands for faster speed of trains. Invidious comparisons were made between the speed of our express trains and those of Europe. Eighteen-hour trains to Chicago and three-day trains to San Francisco were in demand, and the editors professed to believe that such speeds could be accomplished with perfect safety. Fast-speed trains were put on to meet with

## JUST PUBLISHED The Walschaert Locomotive Valve Gear

By W. W. WOOD.

Nearly 200 pages.

Fully Illustrated.

PRICE \$1.50

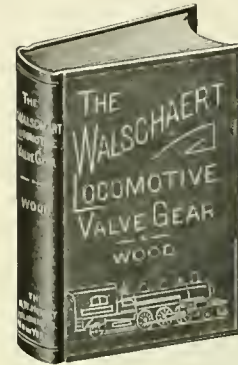

The only book issued that is devoted exclusively to the Walschaert Valve Gear, and it fills a demand which, during the last few months, has become very important. If you would thoroughly understand the Walschaert Valve Gear you should possess a copy of this book, as the author takes the plainest form of a steam engine—a stationary engine to the rough, that will only turn its crank in one direction—and from it builds up—with the reader's help—a modern locomotive equipped with the Walschaert Valve Gear, complete. The points discussed are clearly illustrated; two large folding plates that show the position of the valves of both inside or outside admission type, as well as the links and other parts of the gear when the crank is at nine different points in its revolution, are especially valuable in making the movement clear. These employ sliding cardboard models which are contained in a pocket in the cover.

The book is divided into four general divisions, as follows: I. Analysis of the gear. II. Designing and erecting the gear. III. Advantages of this gear. IV. Questions and answers relating to the Walschaert Valve Gear, which will be especially valuable to firemen and engineers preparing for an examination for promotion.

Just Issued—1907 Revised and Enlarged Edition.

UP-TO-DATE

## AIR BRAKE CATECHISM

By ROBERT H. BLACKALL.

PRICE \$2.00

The Standard Book on the Air Brake. Contains over 2,000 Questions and Answers giving a detailed description of all the Old Standard and Improved Equipment.

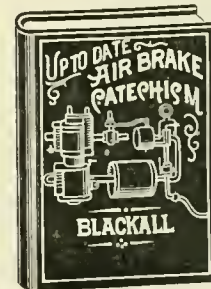

Owing to the many changes and improvements made in the Westinghouse Air Brake it has been found necessary to issue the new, revised 1907 edition of the Air Brake Catechism, which contains all the latest information necessary for a railroad man to pass his examination on the new style of brake.

The new revised 1907 edition is right up to date and covers fully and in detail the Schedule E. T. Locomotive Brake Equipment, H-5 Brake Valve, SF Brake Valve (Independent), SF Governor Distributing Valve, B-4 Feed Valve, B-3 Reducing Valve, Safety Valve, K Triple Valve (Quick-Service) Compound Pump.

Send for a special circular of these books as well as our Other Railroad Books. Copies of these books sent prepaid on receipt of price.

Agents Wanted Write for our special terms. You can make equal to a month's pay selling our books on the side.

The Norman W. Henley Publishing Co.  
132 Nassau St., New York, U. S. A.



# Men Wanted for High Salaried Positions

Owing to the great demand for men with technical training to fill gaps caused by promotion, the Pennsylvania Railroad has sent out a plea to the presidents of universities and colleges asking that more men be urged to prepare for railroad careers. As a result it is understood that the heads of several institutions will recommend special departments for instruction in railroad work. The demand for trained men is now due to the improvements in and about New York and to extensions of the system. Engineers and operating officials are needed.  
New York Times

This is proof positive that there are better paying positions waiting for you if you will qualify yourself to fill them. This is a very simple thing to do. Thousands of railroad men have done it before you through I. C. S. courses of training. You secure this necessary technical training in your own home, in your spare time, and at low cost. If you really want a better position, mark and mail the coupon below and we will tell you the surest and quickest way in the world to get it. Don't indulge in the putting off habit. Send us the coupon NOW.

## International Correspondence Schools BOX 805, SCRANTON, PA.

Please explain, without further obligation on my part, how I can qualify for a larger salary and advancement to the position before which is marked X.

General Foreman R. R.	R. R. Con. Engineer
R. R. Shop Foreman	Civil Engineer
R. R. Trav. Engineer	Bridge Engineer
R. R. Trav. Fireman	Chemist
Locomotive Engineer	Mining Engineer
Air-Brake Instructor	Architect
Air-Brake Inspector	Bookkeeper
Air-Brake Repairmen	Stenographer
Mechanical Engineer	Ad. Writer
Mechanical Draftsman	French } With
Machine Designer	German } Edison
Electrical Engineer	Spanish } Phonograph

Name \_\_\_\_\_  
St. & No. \_\_\_\_\_  
Employed by \_\_\_\_\_ R. R.  
City \_\_\_\_\_ State \_\_\_\_\_

what was reported to be the popular demand. Now there is a very different sentiment prevailing. A few serious accidents have happened to fast trains during the severe winter, and now the publications that did so much to have them introduced are howling to have the speed reduced without delay.

On March 19, 1907, the J. M. Carpenter Tap and Die Company, of Pawtucket, R. I., broke ground for their new factory. The building will be of brick construction, practically fire-proof, covering 24,000 square feet of floor space, and increasing their manufacturing facilities 75 per cent. It may be said that while the company has been reasonably prompt in filling orders, they expect by their in-



THE CARPENTER TAP.

creased facilities to better serve their patrons in the future, and will be able to promptly fill all requirements in their well-known line of tools for cutting screw threads, including taps, dies, die stocks and tap wrenches.

This company began business thirty-seven years ago, and are thus among the pioneer machine screw tapmakers of this country, having many years ago put the machine screw tap on the market. The company have steadily maintained a high standard of quality in their goods for nearly half a century.

### Curious Ideas About Speed.

We have seen the statement made repeatedly that an automobile runs faster at night than in the daytime. Why should it? The difference is in the imagination of the driver who makes such a discovery. We know that young, timid locomotive engineers often share such views about the speed of their engines.

Many years ago a discussion arose in New York concerning the speed of machinery at night, some persons claiming that electric machinery ran faster during the hours of darkness than when the light of day was shining upon it. The matter became so serious that the editor of a scientific paper purchased a speed indicator and made a series of elaborate tests. It is needless to say that he found there was no difference in the velocity of the wheels due to light or darkness.

The Ashcroft Manufacturing Company have just issued a finely illustrated catalogue of 135 pages with brief but complete descriptions of their various mechanical specialties which have

made their name familiar to the engineering world. Chief among these are their steam pressure and vacuum gauges, the Edson recording gauge, the Tabor steam indicator, to which are added a general line of engineering instruments including stocks and dies, ratchets, pipe taps and tongs, and indicator parts and supplies. The superior quality of the Ashcroft Company's output requires no praise at our hands.

The steady growth of their expanding factories at Bridgeport are a splendid monument to the increasing popular favor with which their work is being received. Their most recent additions embrace a comprehensive testing apparatus which is the most complete of its kind in America, and, perhaps, in the world. Among the most recent additions to their numerous mechanical devices in a low water detector and alarm which is rapidly coming into popular use. Engineers should send for a copy of the 1907 Catalogue to the General Office, 85-89 Liberty St., New York.

### Lehigh Adds to Floating Equipment.

The steel sea-going tug "Irvington" has just been received by the Lehigh Valley Railroad Company from the Burlee Dry Dock Company, Port Richmond, Staten Island, and is being fitted for service. The "Irvington," on its trial trip, proved to be satisfactory in every way. This boat is a sister tug to the "Wyoming," which was received about a month ago. These tugs are the largest in the service of the company, and will augment the sea-going fleet in service between Perth Amboy, Boston and East. The vessel is 152 ft. in length; beam, 28 ft. 6 ins.; depth of hold, 16 ft. It has a 4-furnace Scotch boiler, 15 ft. in diameter, 12 ft. long, carrying 180 lbs. of steam. Its engines are triple expansion, 17, 25, 43 x 30 ins. stroke, and will develop 900 H. P. Its bunker capacity is 300 tons of coal, and its towing capacity 6,000 tons.

The Union Switch and Signal Company, of Swissvale, Pa., are now making a number of improvements to their plant at Swissvale, which, when completed, will practically double the productive capacity of these works. During the past year, the company's business increased to such proportions that the management found themselves greatly handicapped for room, and as the orders during the last few months have continued to demonstrate the permanency of this increase, the board of directors recently purchased thirty-four acres of land adjoining their plant for the purpose of adding to the shops. The company decided to grade ten acres of this

plot at once. Switching tracks will be put in, which will be of immediate advantage, and the lumber yard will be removed to the new site.

Plans are now being drawn for a new building to contain a foundry, a blacksmith shop, and a power house, and when these structures are completed the company will have 140,000 additional square feet of floor space for manufacturing purposes. The Union Switch and Signal Company is probably the oldest concern in the country engaged in manufacturing railroad safety appliances, and the experience which their engineering staff has accumulated is now greatly appreciated by the railroads, since the application of safety appliances to railroads has become a necessity.

#### Band Scroll Saw.

This machine will appeal strongly to those desiring a band saw for a large variety of light or heavy work. The column of this machine is a substantial, cored casting, its form being such as to give the greatest freedom of movement to the

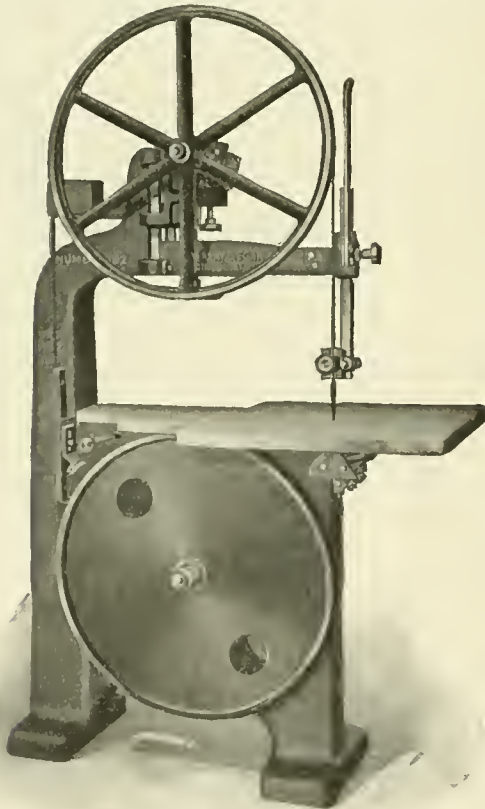

BAND SCROLL SAW.

operator. The wheels, which are 33 in. in diameter, are taper fitted on to the shafts, which run in long bearings.

The upper wheel is carried on a saddle vertically adjustable by means of a hand wheel, convenient to the operator, for varying the length of the saw blade. The bearing is mounted on a knife edge and fitted with the patent sensitive strain-

ing device, shown in our illustration, thus maintaining an even tension of the blade at all times.

The lower wheel is solid webbed, and its weight gives it a momentum which continually controls the lighter upper wheel. The machine has an iron table 24 x 26 ins., which may be tipped to any angle up to 45 degs., and is securely locked in any position. The height from floor to top of table, 37½ ins. The upper guide, which is of the new roller type, is carried on a square bar, insuring permanent alignment. It has a vertical adjustment for any distance up to 12 ins. above the table. The height of machine over all, 6 ft. 9 ins.

The manufacturers of this band scroll saw are the J. A. Fay & Egan Co., Cincinnati, O. They will be happy to supply any information to those interested.

#### Where is the Cold Chisel?

An automobile factory may be regarded as one of the most modern industrial establishments, and therefore we might expect to find in such places the very latest methods of producing and finishing work. I visited a very large, thoroughly up-to-date automobile shop lately and was surprised at the absence of a tool that used to be very much in evidence in my shop days. That was the cold chisel. I did not enter upon shop drudgery before the advent of the shaper and planer, but I got there when many men were still toiling daily who preferred using the cold chisel rather than the machine, unless the job called for a deep cut.

Those were the days when cold chisels were fondled and kept in condition for fine cutting. No barber paid more attention to his razor than the machinist paid to his chisels when chipping was in vogue. But grinders and shapers and millers have banished the cold chisel from modern work.

The McConway & Torley Company of Pittsburgh, Pa., have issued in vest pocket form an abstract of the decisions of the Arbitration Committee of the Master Car Builders' Association from case 704 to case 712, inclusive, November, 1906. These decisions are official interpretations of the M. C. B. Code of car interchange rules, and are useful to those who wish to know how to act in similar cases. The little pam-

## Tate Flexible Staybolt

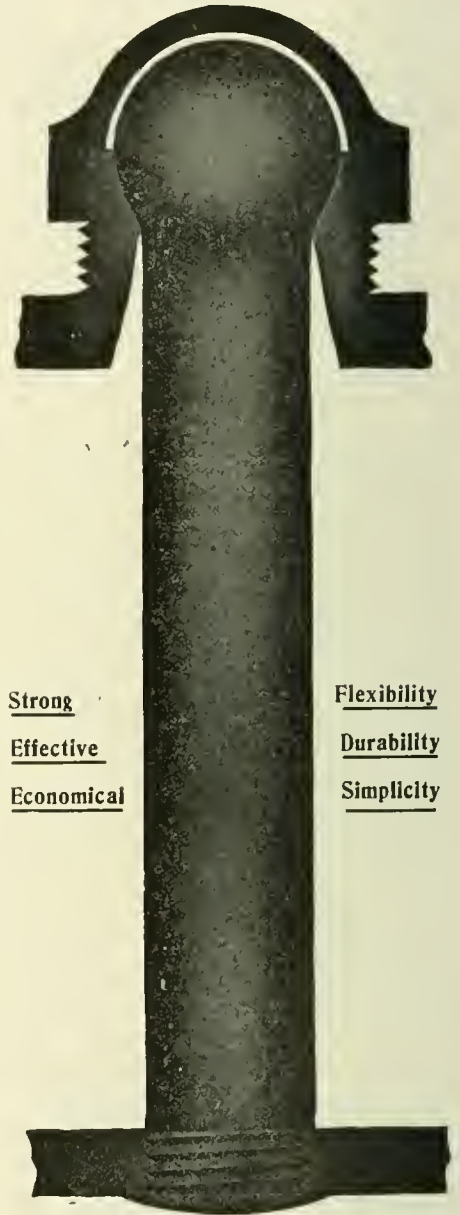

Strong  
Effective  
Economical

Flexibility  
Durability  
Simplicity

Holds firebox sheets securely together, and accommodates itself to the unequal expansion of the plates.

## FLANNERY BOLT COMPANY

PITTSBURG, PA., U. S. A.

Suite 308, Frick Bldg.

B. E. D. STAFFORD, - General Manager  
Write us for Reference Book

# Homestead Valves

Straightway, Three-way and Four-way, and

# Homestead Locking Cocks

Are Famous the World Over

They cost more, but are worth very much more than other makes. You try them and see.



Brass, 1 1/2 in.

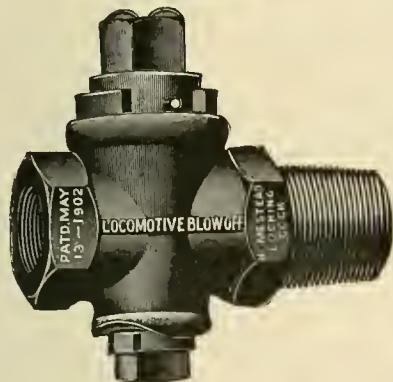

Iron Body, Brass Plug, 1 1/2 in.

**HOMESTEAD VALVE MFG. CO.**

WORKS: HOMESTEAD, PA. PITTSBURG, PA.

## American Locomotive Sander Company

13th & Willow Sts., Philadelphia, Pa.

Proprietors and Manufacturers

LEACH, SHERBURNE, DEAN, SANDERS  
HOUSTON, "She" and CURTIS

**THE ROBERT W. HUNT & CO.**

Bureau of Inspection, Tests and Consultation,  
1137 THE ROOKERY, CHICAGO.

66 Broadway, New York.

Park Building, Pittsburg.

31 Norfolk House, London, Eng.

Inspection of Steel Rails, Splice Bars, Railroad Cars, Wheels, Axles, etc. **CHEMICAL LABORATORY**—Analysis of Ores, Iron, Steel, Oils, Water, etc. **PHYSICAL LABORATORY**—Test of Metals, Drop and Pulling Test of Couplers, Draw Bars, etc.

Efficiency Tests of Boilers, Engines and Locomotives.

phlet forms a supplement to the Car Interchange Manual issued by this well-known coupler company. The pamphlet can be pasted in the back of the manual. Write to the McConway & Torley Company if you want a copy of this abstract of decisions.

### Improved Track Drill.

The difficulties heretofore encountered by tracklayers in drilling rails in position have been very satisfactorily overcome by improvements recently made in the mechanism of the Cook standard track drill, shown in our illustrations. The ball bearings of this tool, as it is now made, are encased in highly tempered tool steel "racers" of improved construction. They are self-contained in such a way that the balls cannot be lost out of the racers, nor will they fall out when

is accomplished by means of a crank at the end of the feeding screw whereby the drill bit may be quickly screwed up to the work, or returned, as desired. The rapidity with which the spindle can be moved forward or back renders it unnecessary to collapse the drill, except when trains are actually passing over the track.

The H. A. Rogers Company, 19 John street, New York City, who have been prominent for many years as dealers in railroad and machinists' supplies, are the exclusive selling agents for this drill in the Eastern and Southern States, and will be pleased to send circular and full particulars on application.

### Accidental Discoveries.

The metal business owes many valuable discoveries to accidents that happened

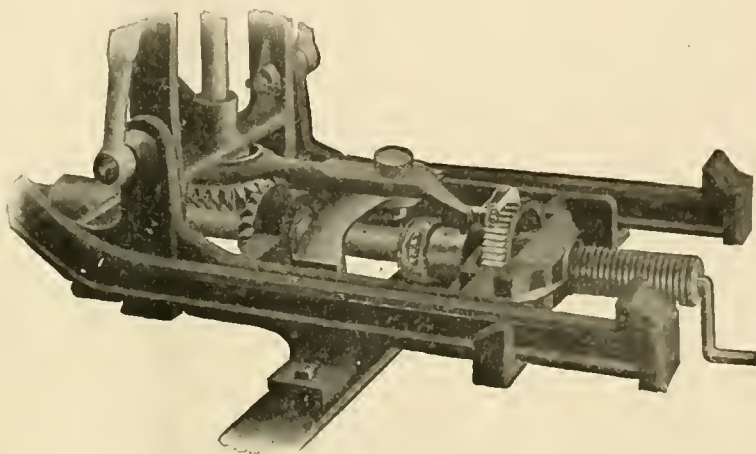

COOK STANDARD TRACK DRILL.

the bearings are put on or taken off. This operation is accomplished by merely unscrewing a set screw.

The method of absorbing the thrust due to drilling, eliminates the cutting of the thrust bearing, which is a common drill trouble, the friction at the thrust point having been reduced in this design, and the power exerted on the handles of the drill is almost entirely used at the bit point in cutting through the rail, and not lost as friction in the drill mechanism. As a further means of absorbing the bit thrust and reducing friction to a minimum, a square nut, internally threaded to fit the feed screw, is made to take the thrust. The ratchet wheel, heretofore held as if in a vise, being thus relieved of the thrust, revolves easily, and so prolongs the life of the pawls, cam, the forks at the end of the "walking beam" or arm, the gears and all other parts likely to become worn.

Another feature of the Cook standard track drill in its improved form is the "quick return" of the drill bit. This

under the notice of men who had acquired habits of observation, and the capacity of reasoning from cause to effect. Malleable iron was discovered by Seth Boyden noticing that the texture of a cast-iron grate had changed through the bar getting burned.

While R. Mushet was experimenting with tool steel he found that one bar had acquired the property of self-hardening without being quenched in water. That bar was a mystery for a time, till it was discovered that tungsten had been mixed with the iron from which the steel was made.

In the dressing of Mushet steel tools, Henry Gladwin noticed that tools thrown on the floor after forging and cooled by the air draft passing under a door did better work than those cooled in a bin. That led to tests of cooling under an air blast, and it effected a very important improvement.

It is the law of good economy to make the best of everything. How much more to make the best of every man.

### Medal from Liege.

The Armstrong Brothers Tool Company of Chicago have been awarded a medal for their exhibit of lathe and planer tool holders, at the recent International exhibition at Liege, Belgium. This company are "the tool holder

1302.45 sq. ft.; boiler pressure, 160 lbs. They are equipped with the Westinghouse brake and the New York duplex pumps. The engines are painted a light green, with black bordering lines in yellow, while the frames are reddish brown.

At the beginning of this month the Chicago branch of Niles-Bement-Pond Company occupied their new offices on the sixth floor of the new Commercial National Bank Building, Clark and Adams streets, Chicago, Ill. In this building there are also many large engineering and steel companies. The Pratt & Whitney Company left their show room and offices at 46-48 South Canal street, and combined their machinery sales department with that of Niles-Bement-Pond Company. The show room and stock of Pratt & Whitney small tools, and the small tools sales department, are on the ground floor of the new Plamondon Building, at the corner of Clinton and Monroe streets, where a complete line of Pratt & Whitney small tools and gauges is carried in stock. Mr. Geo. F. Mills, who has for several years looked after the interests of these companies in the Chicago territory, is manager of the Chicago offices.

A change of company name of more than usual interest recently took place. The Sawyer-Man Electric Company will hereafter be known as the Westinghouse Lamp Company. Thus the name of the pioneer company in the lighting industry becomes a matter of history. It has, of course, been generally understood for some years past that the Sawyer-Man Electric Company was a Westinghouse interest, and

people" and their three bar boring tool is a very serviceable article.

A slight turn of one nut releases or fastens both bar and holder. Bars can be changed as needed almost instantly, thus allowing the operator to use the stiffest bar possible for each job with the result that speeds and feeds can be increased and time saved. The tool holder is very stiff and is made from bar steel throughout. The cutters are so held that the strain of cut holds them tighter. The convenience of this late attachment is appreciated by many practical machinists who use them.

### Dutch State Railway Express.

The engine shown in our illustration is used in express service on the Dutch State Railways, of which a series of one hundred and thirty-five engines



DUTCH STATE RAILWAY EXPRESS ENGINE.

have been built by Beyer, Peacock & Co., of Manchester. These engines are provided with Serve tubes  $2\frac{3}{4}$  ins. outside diameter, which are cleaned by steam taken from a small cock placed at the front of the smoke box and directed from a jet at that end.

Some of the principal dimensions are cylinders, 18 x 26 ins. Driving wheels, 7 ft. diameter. Total heating surface,

the change of name is but the result of changed conditions.

### Wooden Rolling Doors.

The Kinnear Manufacturing Company of Columbus, Ohio, who are widely known as the makers of the Kinnear steel rolling doors for round-houses, street car barns and other buildings, have lately put upon the

## Oliver Lippincott Photographer

20 John Street, New York

Process and Mechanical Prints

Perfect reproduction from Tracings, Black Lines, White Paper, any size, for Specifications and Estimates.

# THE UNION SWITCH & SIGNAL COMPANY

CONSULTING  
AND MANUFACTURING  
SIGNAL ENGINEERS

Automatic Block Signals—Electric  
and Electro-Pneumatic

Interlocking—Electric, Electro-  
Pneumatic and Mechanical

Electric Train Staff Apparatus

General Offices and Works at  
SWISSVALE, PA.

### DISTRICT OFFICES:

NEW YORK - - 143 Liberty Street  
CHICAGO - - - Monadnock Block  
ST. LOUIS - - - Frisco Building

**THE TANITE CO.**  
seeks the support of  
Railroaders because:

The man who uses a TANITE wheel will find it safe. Because pay for a TANITE wheel secures the greatest productive capacity. Because TANITE MILLS EMERY is mined in America and appeals to all who earn wages in America. Because TANITE grinding machines are practical.

THE TANITE CO. sells Emery, Solid Emery Wheels, Buffing Lathes, Guide Bar Grinders, Car Brass Grinders, Bench and Column Grinders, Surfacing Machines, Open Side Emery Planers, Saw Gummets, Automatic Planer Knife Grinders, Diamond Tools, Polishing Paste for Brass and Nickel, Emery Wheel Cutters and Dressers.

The Tanite Co. builds special machines  
for special wants

**THE TANITE CO.**  
STROUDSBURG, PA

## Locomotive Blow-Off Plug Valves

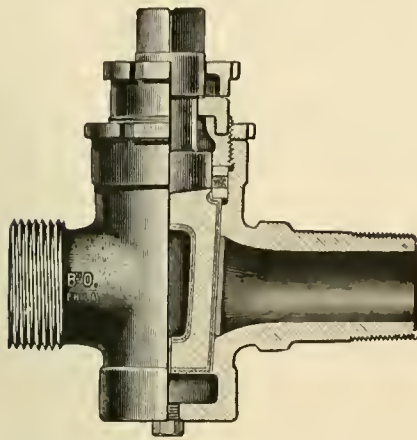

Fig. 9.

All Brass, extra heavy, with Cased Plug. For 250 lbs. pressure. Made with Draining Plug to prevent freezing.

market a wooden rolling door which embodies the same principle as that used in the steel doors.

This new door is constructed of a curtain proper, composed of wood slats strung on phosphor bronze ribbons.

the curtain shaft, or barrel, gears and hoists. On the barrel are placed spiral cast iron rings to which the suspending ribbons are attached so that after the first turn of the slats around the shaft the roll is always a true spiral.

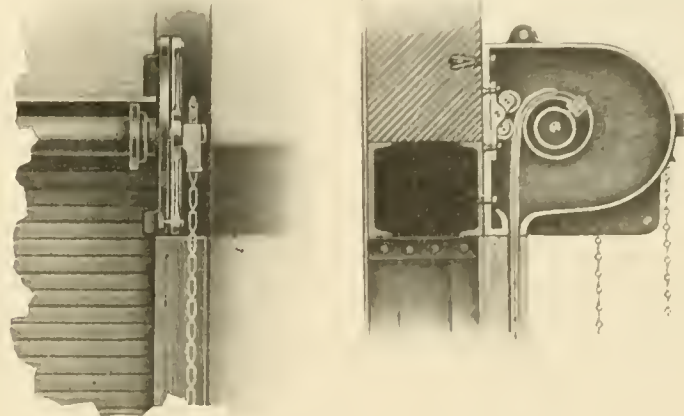

OPERATING MECHANISM AND CASE FOR ROLLED DOOR.

The edges of the curtain travel in wood grooves at the sides. The curtain is suspended and rolls upon a barrel consisting of a boiler tube of sufficient diameter to afford absolute stiffness and which contains within it the helical springs necessary to counterbalance the weight of the curtain. The ends of this tube are closed by cast iron plugs, and thus the springs

On the rear flange of the brackets and behind the curtain proper, is carried a pivoted cradle in which operates two rollers. On the bottom of the brackets are suitably curved projections forming a throat which serves to guide the curtain properly down into the groove.

It will be seen from our illustrations that the curtain tends at all times to hang vertically from the shaft, with the

## Locomotive Gauge Cocks

For High Pressure

Bordo Self-Grinding Gauge Cocks, made with renewable Hard Bronze Disc. Opened and closed with a quarter turn. Guaranteed Steam tight under the most exacting conditions. Shanks Threaded to specifications for Locomotives.

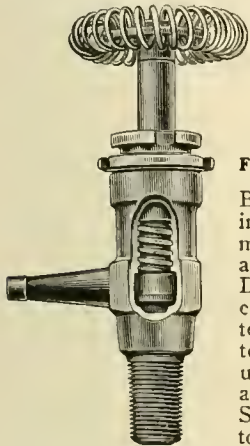

Fig. 23, with Wheel.

## Swing-Joints and Pipe Attachment



Fig. 33.

May be applied between Locomotive and Tender. These Swing-Joints are suitable for Steam, Gas, Air, Water or Oil.

Complete Booklet on Application  
**L. J. BORDO CO.**  
PHILADELPHIA, PA.

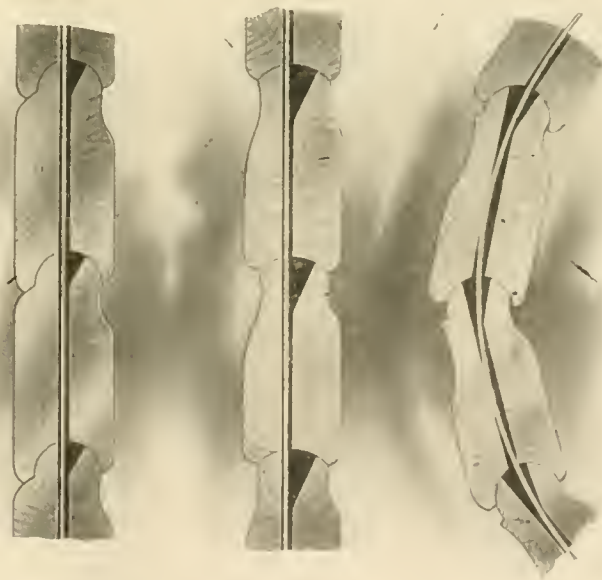

SECTIONS OF THE WOODEN ROLLING DOOR.

are thoroughly protected. The whole is supported on brackets of heavy cast iron.

Pivoted at the upper and lower corners of the brackets are two heavy radial arms, extending in opposite directions with their free ends connected by a horizontal link bar which carries

coil bearing against the rollers at the back of the brackets. The pressure of the rollers is very light, owing to the nearly vertical position of the radial arms. As the door is rolled up, and the diameter of the roll necessarily increases, the whole shaft is pushed forward horizontally being carried by the

This illustration shows the form of construction of the

## Dart Patent Union

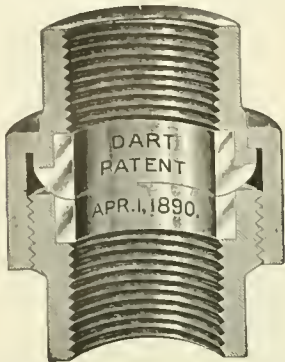

Every feature of construction represents the best points to insure stability and durability. The malleable iron pipe ends and nuts, in combination with bronze metal seats, are as near perfection as is possible to approach, and the sales to date indicate the public approval. There are none so good. For sale by all the principal jobbers to United States, Canada and Europe.

**E. M. Dart Mfg. Co., Providence, R. I.**  
FAIRBANKS CO., SALES AGENTS.

**MICA**  
CABOOSE LAMP CHIMNEYS  
Save 50 per cent.

STORRS MICA CO.,  
R. R. Dept. Owego, N. Y.



## The Twentieth Century Master Mechanic

Won't use Solid Mandrels.  
Cost too much, take up too much room and don't give satisfaction.

### Nicholson Expanding Mandrels

Take everything from 1 to 7 inch holes. Take up little room—always ready and you can buy four sets for the cost of one of the solid kind.

### Are You Using Them?

Catalogue tells you more about them.

**W. H. Nicholson & Co.**  
Wilkesbarre, Pa.

pivoted arms until the entire capacity of the brackets is occupied and the door fully opened. The process is, of course, reversed as the door is closed.

This method is simple and sure and secures a vertical hang of the slats from the shaft at all times, thereby reducing wear and preventing the dragging of slats over any projections. A space is left between the first and second slats at the top to accommodate any movement of the slats on the ribbon, due to swelling or shrinking of the wood. The method of attaching the ribbons to the rings is to bend the ends of the ribbon around the top slat and bolt through both slat and ribbon, thus putting no direct tearing strain on the thin metal of the ribbon and eliminating sharp bends. The lower end of ribbon is secured to adjustment bolts in a heavy stiffening-bar fitted to the bottom of the curtain.

Some of the forms of slats are shown. Ribbons are threaded through slots in the slats every  $2\frac{1}{2}$  ins. The transverse form of these slots has been scientifically calculated and accurately cut and the flexure of the slats round the barrel does not change the relative length of ribbon and slats. The transverse form of the slat is such as to give the maximum amount of material and at the same time the head of the slat is so formed that the overlapping lip of the slat above it presents the least amount of unsupported surface when the slats are flexed. The slot or ribbon is never at any time uncovered. When the door is closed the wearing surfaces of the slats upon each other are entirely covered so that there is no chance for dust or grit to get on them.

The curtains are accurately counter-balanced and are very easily operated. The slats are treated with a water proofing compound, but they are painted after erection to conform to the finish of the building. The makers state that one of these doors 13 ft. wide by 17 ft. high has been operated over 1,800 times by common laborers in a shop, without showing appreciable wear. The time required to operate this door is 30 seconds.

#### Ancient Wisdom.

Titus Livius, the Roman historian, tells us that one of the maxims constantly inculcated by his instructors was, "*Nentes, aut preece*," or, in other words—Attempt not, or accomplish thoroughly. This is as good advice to-day as it was two thousand years ago. A smatterer never will amount to anything. The perfect mastery of some particular calling is the high road to success. The path leading to knowledge is often strewn with difficulties. This is especially the case in

every department of railroad work. The complex mechanism, the many details, the numerous rules and regulations render a thorough knowledge of the duties appertaining to any branch of railroad work difficult of accomplishment.

Right here, RAILWAY AND LOCOMOTIVE ENGINEERING supplies the necessary material. Its pages are filled with the expressions of the best thoughts of the leading railroad men of our time. It has met the universal approval of the leading railway men throughout the world. The price, \$2.00 a year, places it within the reach of every railroad employee.

"Twentieth Century Locomotives," Angus Sinclair Co., deals comprehensively with the design, construction, repairing and operating of locomotives and railway machinery. First principles are explained. Steam and motive power is dealt with; workshop operations described, valve motion, care and management of locomotive boilers, operating locomotives, road repairs to engines, blows, pounds in simple and compound engines; how to calculate power, train resistance, resistances on grades, etc. Shop tools explained. Shop recipes, definitions of technical terms, tables, etc. Descriptions and dimensions of the various types of standard locomotives. The book is well and clearly illustrated and is thoroughly up to date in all particulars, fully indexed. Price, \$3.00.

"Locomotive Engine Running and Management," by Angus Sinclair, is an old and universal favorite. A well-known general manager remarked in a meeting of railroad men, "I attribute much of my success in life to the inspiration of that book. It was my pocket companion for years." Price, \$2.00.

"Practical Shop Talks." Colvin. This is a very helpful book, combining instruction with amusement. It is a particularly useful book to the young mechanic. It has a stimulating effect in inducing him to study his business. We sell it for 50 cents.

Spangenberg's Steam and Electrical Engineering has 672 pages, 648 illustrations. It may be called a complete library in one volume, and is in question and answer form; which is an easy way of obtaining useful information. Covers a wide field. Fully indexed for reference so that any subject may be readily turned to and answer found. Price, cloth, \$3.50.

The 1907 Air Brake Catechism, by C. B. Conger. Convenient size, 230 pages, well illustrated. New edition. Up-to-date information concerning the whole air brake problem, including the ET equipment in question and answer form. Instructs on the operation of the Westinghouse and the New York Air Brakes, and has a list of examination questions for enginemen and trainmen. Bound only in cloth. Price, \$1.00.

**STANDARD MECHANICAL BOOKS  
FOR ROAD AND SHOP MEN  
BY CHAS. McSHANE.**

**The Locomotive Up to Date**

Price, \$2.50

**New York and  
Westinghouse Air Brakes**

Price, \$1.50

**One Thousand Pointers for  
Machinists and Engineers**

Price, \$1.50

All books bound in fine cloth.

AGENTS WANTED everywhere; write for terms and descriptive circulars. Will be sent prepaid to any address upon receipt of price.

**GRIFFIN & WINTERS**

171 La Salle Street, CHICAGO

**TOOL  
STEEL**

**Die Blocks  
Steel Forgings**

First Prize awarded at the Louisiana Purchase Exposition, at St. Louis, for our TOOL STEEL when placed in competition with the best makes in England and Germany.

Write for information and Prices. Specify McInnes Tool Steel when ordering.

**McINNES  
STEEL CO.**

CORRY, PA.

"Compound Locomotives." Colvin. This book instructs a man so that he will understand the construction and operation of a compound locomotive as well as he now understands a simple engine. Tells all about running, break-downs and repairs. Convenient pocket-size, bound in leather, \$1.00.

"Catechism of the Steam Plant." Hem-enway. Contains information that will enable a man to take out a license to run a stationary engine. Tells about boilers, heating surface, horse power, condensers, feed water heaters, air pumps, engines, strength of boilers, testing boiler performances, etc., etc. This is only a partial list of its contents. It is in the question and answer style. 128 pages. Pocket size, 50 cents.

"Care and Management of Locomotive Boilers." Raps. This is a book that ought to be in the hands of every person who is in any way interested in keeping boilers in safe working order. Written by a foreman boilermaker. Also contains several chapters on oil burning locomotives. Price, 50 cents.

"Locomotive Link Motion." Halsey. Any person who gives a little study to this book ceases to find link motion a puzzle. Explains about valves and valve motion in plain language. Price, \$1.00.

Storage Batteries for Stationery Service, Catalogue S, is the most recent publication of the Westinghouse Machine Company. It is an elegant pamphlet of 32 pages, with letterpress descriptions and accompanying illustrations of the latest forms and structures of the storage batteries manufactured by the company. The descriptions are particularly interesting and valuable to all who are interested in the formation of storage batteries. The style of writing is free from technical phrases or abstruse calculations, and is, as all such works should be, readily understood by the merest beginner in the study of electricity. The Westinghouse Company have spent plenty of money and for many years have employed a corps of accomplished engineers in the study, development and perfection of their manufactures, of which the storage battery may be said to be among the most perfect. It is to the credit of the enterprising company that there is no tendency shown on their part to make a mystery of their many inventions and improvements. The catalogue is itself an educational work of marked value, and copies may be had on application to the company's publishing department at East Pittsburgh, Pa.

**Hoodooed the Elks.**

Some years ago the Lodge of Locomotive Firemen at New Haven, Conn., rented for their meetings the hall of the order of Elks. Some months afterward the firemen raised enough money to buy a valve-motion model for the instruction

of the members. The Chief Fireman asked the Chief Elk where they could set up the model and was told to put it in the banquet room, but to have a case put over it so that it would escape injury from the butting of the Elks. A carpenter was employed to make a case that would take up as little room as possible. The case was made, stained black, and when it was set up on legs it looked like a small coffin.

A few days after the valve model had been installed the Chief Elk called upon the Chief Fireman and demanded to know what he had got in that casket. Said the Chief Elk: "We tried to have a little banquet after initiation last night, but the boys could not be cheered up with that thing there and the function was as solemn as a funeral service. It was voted that you remove the remains or get a new hall. We do not rent a vault."

The dwellers in New York City, who sweat and groan under the load of a weary life during the summer months,



WRECKED.

seem largely to be unaware of the gorgeous panorama of Nature in her beauty and solitude that lie at their doors. From the roof of the skyscrapers the unaided eye can almost sweep the entire green and golden vista that spreads from Brooklyn Heights to Montauk Point, and mark the far-stretching archipelago with its thousands of wave-washed islets that lie like bright emeralds set in a sea of silver. In summer the great island and its myriad satellites are supremely beautiful. Inland are the gardens of Holland, the orchards of England and the fields of France in the glow and glory of luxuriant freshness. From the blue Atlantic the cooling breeze comes filling the lazy lungs with the vigor of youth. Quiet farm houses, sleepy hamlets, cosy boarding houses, colossal caravanseries, all are there for the choosing. Every kind of taste and every size of purse can be suited. Especially can the tired mechanic, whose every penny means self-denial crystallized into coin, come there and renew his youth cheaply and effect-

# One Year and Eleven Months' SERVICE

WITHOUT REPACKING. ON

## High-Pressure Locomotives

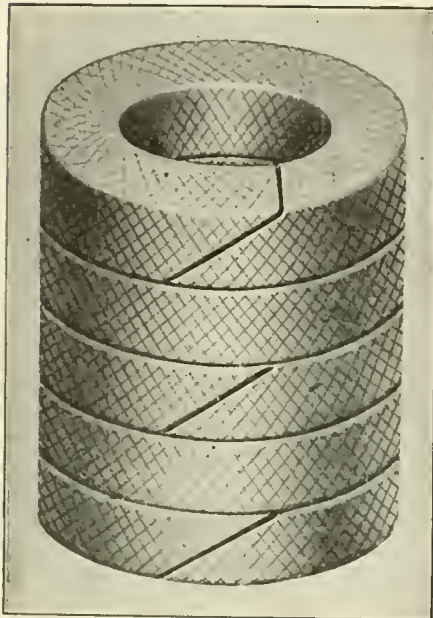

Style 300 TV.

A throttle failure is an absolute impossibility where Crandall's Throttle Valve packing is used.

IT WILL NOT BLOW OUT

## Crandall Packing Co.

FACTORY AND GENERAL OFFICE

PALMYRA, - - NEW YORK

BRANCHES

New York

Cleveland

158 Liberty St.

9 So. Water St.

Chicago

52 West Washington St.

## Directory of Railways of the World

The Universal Directory of Railway Officials, published in London, contains a list of the entire railroads of the world, with physical particulars and names of all officials.

Send Your Order Now

for the 1906 edition.

Price \$3.00 Prepaid

A. FENTON WALKER

Sole Representative for U. S.

143 Liberty St. New York

ally. The millionaire, who feels burdened with the weight of his wealth, need not sail the seas further than to Manhattan Beach. He will get his money's worth right there. Before settling on a vacation, the tired worker should get a copy of the finely illustrated pamphlet issued by the Long Island Railroad Company, and have his eyes opened. Mr. R. M. Smith, general passenger agent, New York, is the one to apply to for information concerning Long Island.

### Engineering Societies Building.

The United Engineers Society recently opened their new building at 29 West Thirty-ninth street, between Fifth and Sixth avenues, in New York. This is the Engineers' Club for the erection of which Mr. Andrew Carnegie gave \$1,500,000. Rising thirteen stories high, with a frontage of 125 feet, the Engineers' Club is an imposing structure overlooking Bryant Park and the New York Public Library. The construction is of steel covered with two to four inches of porous terra cotta, and the columns are grounded with concrete. The floors are of six-inch hollow tile blocks in segmental arch overlaid with five inches of concrete. The walls are furred with terra cotta blocks, to keep out damp and prevent the spreading of flames in case of an outside fire. Particular attention has been given to the fireproofing because of the valuable scientific records and the material which the building will contain.

The idea which led to the erection of the Engineers' Club was to bring together the various engineering societies of the United States, where they would have a common meeting ground for annual conventions, scientific lectures and demonstration and to provide quarters for the national societies of Mechanical, Electrical and Mining Engineers, as well as for such associate societies as might require headquarters in New York. While each is to maintain its individual character all are to unite in advancing the engineering arts and sciences.

A prominent feature of the building is the large auditorium capable of accommodating 1,000 persons. Another is the free public library on the top floor. Heretofore, owing to the headquarters of the various societies being scattered, there has necessarily been duplication in these libraries. Under the new arrangement all have been brought together. This concentration has given the Engineers' Club the finest and most complete library of its kind in the United States. The New York Railroad Club holds its monthly meetings in this building.

The American Locomotive Company's exhibit now at the Jamestown Exhibition occupies a plot 100 x 250 ft. in the southern portion of the grounds on

*Perfect*

Why pay more for a Car and Locomotive Cleaner, when the "PER-FECT" will do the work and better at 48 cents per gallon, f. o. b. Philadelphia or Chicago?

THE MODOC SOAP CO.  
228 North Fourth Street  
PHILADELPHIA, PA.

the south-easterly side of Lee's parade grounds. The exhibit is housed in a building especially constructed for the purpose 177 ft. long and 20 ft. wide, with the entrance facing the parade. The exhibit consists of one Consolidation type locomotive, built for the Southern Railway, with 22 x 30-inch cylinders and slide valves operated by the Walschaerts valve gear; a Pacific type passenger locomotive built for the Chesapeake & Ohio Railway with 22 x 28-inch cylinders and piston valves; a 10 x 16-inch saddle tank Contractor's locomotive and a Class 44-16-2½ Atlantic steam shovel. The steam shovel is outside of the building and is to be in operation under its own steam.

### CONTENTS.

*Suspension Bridges .....	191
Billy's Thermometer .....	194
*Patent Office Department.....	196
*General Correspondence .....	199
Engine Failures .....	203
British Notes and News. A. S. Sinclair....	203
Locomotives:	
*Ten-Wheeler for Peru.....	195
*South African 4-6-4.....	197
*Swiss Locomotives .....	201
*Rail Motor Engine, L. & S. W.....	204
*Baldwin Mogul for China.....	205
*South Shore Switches.....	214
*Dutch State Railway Express.....	232
Cars:	
*Steel Underframe for Wooden.....	198
*Steam Motor Coach, C. P. R.....	205
*Steel Box Car on the U. P.....	209
Editorials:	
Fondness for Old Material.....	206
Low Water Boiler Explosions.....	206
Railroad Legislation.....	207
Electrically Driven Lathes.....	207
Lifting Appliances.....	208
Setting a New Sector.....	208
Book Notices .....	208
Correspondence School .....	211
Questions Answered .....	213
Air Brake Department.....	215
*Electrical Department .....	217
*Mechanical Stoker on the Erie.....	219
Items of Personal Interest.....	223
*Valve Setting Machine.....	227
No More Brain Fag.....	227
*Electric Hoists .....	228
*Band Scroll Saw.....	230
*Improved Track Drill.....	231
*Wooden Rolling Doors.....	232
Engineering Societies Building.....	236



# Railway and Locomotive Engineering

Copyright by Angus Sinclair Co.—1907

A Practical Journal of Railway Motive Power and Rolling Stock

Vol. XX.

136 Liberty Street, New York, June, 1907

No. 6

## Tubular Bridges

In the early days of railroad construction, the art of bridge building was old, but the necessity for carrying heavy and concentrated moving loads, such as railway trains, over built up structures, undoubtedly gave a new impetus to the work. It led bridge designers and engineers eventually to depart from the heavy stone arched

water which separates the mainland of Wales from the Island of Anglesea. The bridge was begun in 1845 to carry the line of the Chester and Holyhead Railway across the Menai strait, and with this unique engineering undertaking is associated the names of three eminent engineers, Robert Stephenson, Sir William Fairbairn and Mr. Eaton Hodgkinson.

Stephenson conceived the idea of

suspension arrangement, and this was the form finally adopted.

The bridge itself consists of two separate tubes or hollow beams carried on two abutments and three piers. The tubes are made of wrought iron plates, and the inside section of each tube is 13 ft. 8 ins. wide throughout by 18 ft. 9 ins. deep at the ends, and 26 ft. deep at the centre. The extreme outside height of the tube at the Britan-

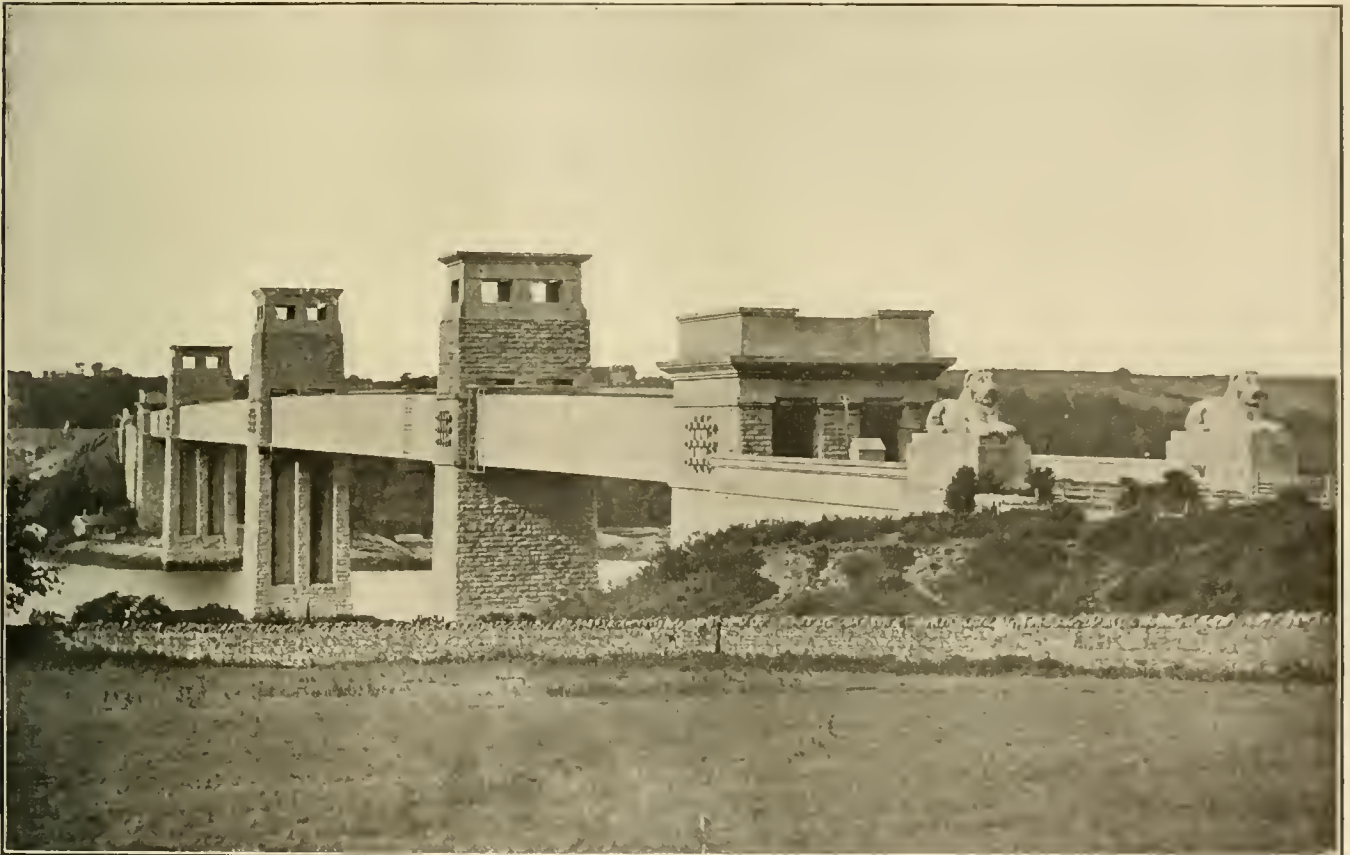

THE BRITANNIA TUBULAR BRIDGE OVER THE MENAI STRAIT.

viaducts, and to build lighter forms of longer spans, made of metal, without in any way sacrificing safety. Many of these designs possessed artistic merit as well as utility, and these features were secured at comparatively much lower cost.

The bridge shown in our frontispiece illustration is the famous Britannia Tubular Bridge over the Menai strait, which is the narrow body of tide

constructing a bridge in the form of a hollow beam, and suspending it by chains from towers. This would have been a suspension bridge having a stiff plate girder. Fairbairn and Hodgkinson made experiments and calculations concerning such a form of suspension bridge. In the course of this work Fairbairn perceived that the box-shaped girder could be made to support itself without the aid of any

nia Tower is 30 ft., diminishing to 22 ft. 9 ins. at the abutments. This difference is for the purpose of giving a true parabolic curve to the top, while the bottom is straight. The shore spans are each 230 feet long, and the water spans are 460 ft. long. The centre or Britannia tower is built on a rock near the middle of the strait and is 230 ft. high. In the erection of this tower no fewer than 150,000 cubic feet

of Anglesea marble, 150,000 feet of sandstone, and 400 tons of cast iron beams and girders were used. The tubes rest solidly on this tower, but are carried on roller bearings on the land towers and the abutments. The bridge thus expands and contracts from a fixed centre. The total length of each tube is 1,511 ft., and each tube is a continuous box girder. They were, however, built in sections the requisite length to fit between the supports and united when in place. The weight of each tube is about 4,416 long tons, or a total for both of 8,832 tons.

Some very onerous conditions were imposed upon the builders. Navigation was not to be interrupted, no scaffolding or false work was to be used, a clear height above the water of 100 ft. was required, and if arches were to be part of the design they would have to spring from points 100 ft. above the water. The tide runs in and out at a velocity of about 9 miles an hour, and notwithstanding these conditions, the bridge was completed and opened for traffic in 1850.

The box girders were built on the shores of the strait and were floated on pontoons to the bridge site. Each section was suspended by four chains and lifted to the required height by the application of hydraulic jacks. When in position a short uniting tube was built through each tower and the girders were thus made continuous. The tubes were reinforced, top and bottom by cells or smaller box tubes made of angles and plates. There are six cells 2 ft. 4 ins. by 1 ft. 9 ins. on the

of the scene. The couchant lions guarding the entrance, carved in stone, are typical of solidity and endurance and the graceful sweep of the parallel lines of the railway enhance the striking picture. The bridge is on the London and North-Western Railway, which acquired the original Chester and Holyhead line, and trains are daily run through this bridge at full speed.



CONWAY CASTLE IN WALES.

On each of the towers may be seen a decorative crossbar device, which suggests the heraldic portcullis. The portcullis was the iron lattice which could be let down in the entrance to the old-time castle, with its drawbridge and its moat. The dropping of this cross-barred iron gate like a huge window sash could be accomplished as a matter of quick defence much faster than the drawbridge could be raised or the ponderous doors shut, and from this fact the iron cross-bars became typical of the castle entrance.

In contrast to the olden days that most distinctly modern work of man,

that known as the Victoria Bridge at Montreal, Canada. In 1846 the question of bridging the St. Lawrence was seriously taken up by the directors of the St. Lawrence and Atlantic Railway and some preliminary work was done. In 1847 a charter for building the bridge was granted by the House of Assembly, but was held up by the Legislative Council. In spite of opposition and delay the bridge was at last begun. The foundation stone of the first pier was laid with great ceremony by Sir Cusack Roney on 22d July, 1854.

The engineers of this bridge were Robert Stephenson and Alexander M. Ross. The original design for the bridge had been made by T. C. Keefer. The contractors were Messrs. Peto, Brassey, Betts & Co. The bridge was completed toward the close of 1859, a year before the contract time. It was formally inaugurated in 1860 by the Prince of Wales, now Edward VII.

The Victoria bridge was a single tube composed of 25 spans. The floor of the centre tube was 60 ft. above the water line, and there was an up grade both ways toward the centre, of 1 in 130. At the abutments the height from the bottom of the tube to the water was much less. The total length of the bridge was with approaches 9,144 ft. Each of the 24 spans was about 242 ft. long. The centre, or channel span, was 330 ft. long. On account of the current, and the Lachine rapids above the bridge, the river is navigable in one direction. The name of these rapids was given by the discoverer of the St. Lawrence river, the French navigator, Jacques



THE MENAI STRAIT WITH TUBULAR AND SUSPENSION BRIDGES.

bottom, and there are eight cells 1 ft. 9 ins. square on the top. The tube is therefore a box with floor and roof stiffened by a series of smaller boxes. The corners of the large tubes were stiffened by gusset plates at each of the ribs which were formed by the junction of the side plates.

The bridge is situated in a lovely section of the country and is an imposing structure which adds to rather than detracts from the natural beauty

the locomotive, outcome of the peaceful arts, has here its iron road, and whatever the significance of the device upon the bridge may be, this magnificent structure stands as the stately gateway to the ancient principality of Wales, as it were, with the portcullis lifted and with bridge floor level for the unchallenged passage to the heart of the kingdom, of the traveler and the commerce from many lands.

Another famous tubular bridge was

Cartier, who, in 1535, was unable to get up these rapids, which he believed stood between him and the Empire of China.

It has been estimated that about 9,044 tons of iron were used in the construction of the tubes, and something like a million and a half of rivets. The total surface of this bridge, which had to be covered with paint, was about equal to 32 acres. The bridge is said to have cost about \$277 per linear foot.

The Victoria tubular bridge was in constant use for practically forty years and the change to the present open girder bridge was made because the old structure carried only a single track, and the increasing business of the Grand Trunk system required a two track bridge. The increased weight of rolling stock, within recent years, was also taken into consideration. The new bridge was begun in 1897, from which fact it has been called the Victoria Jubilee bridge. The old bridge was 16 ft. wide, the new is 36 ft. 8 ins. across and provides double track, and two roadways for vehicles and pedestrians. The new bridge stands upon the piers which carried the old tube and was built around the old bridge while it was in use, with practically no delay to the railroad traffic during the time.

The chief engineer of the Jubilee bridge was Mr. Joseph Hobson, the present chief engineer of the Grand Trunk. The new bridge weighs about 22,000 tons and is 6,592 ft. long. The approaches are longer than was the case with the tubular bridge, the total from shore to shore is, of course, the same in each case. Referring to the old and the new bridges, it has been well said: "The new bridge ranks, from an engineering standpoint, with the foremost structures of the age, as the bridge which it replaced ranked the foremost as a monument to the skill of the engineers and bridge-builders of the period in which it was built."

#### British Board of Trade.

By A. R. BELL.

Although as early as the fourteenth century councils and commissions had been formed from time to time to ad-

improving trade. A few years later another committee of the council was appointed to act as an intermediary between the crown and the colonies, or "Foreign Plantations," as they were then called. Soon the two committees were amalgamated and to this day the official title of this department of the British government is "The Board of Trade and

again reconstituted, all the principal officers of state being admitted to seats ex-officio. Soon, however, the enormous mass of work thrown on the board showed the futility of such concentration of responsibility and a system gradually evolved itself whereby the work of the board was relegated to various departments, the president being retained in



ENTRANCE TO THE BRITANNIA BRIDGE.

Foreign Plantations." Abolished in 1675, the committee was revived twenty years later under William III, with the celebrated John Locke as its secretary, and set to work to remove trade obstacles, to provide employment for the poor and to improve the state of the currency. Locke retired in 1700 and the board again fell into comparative obscurity. In 1760 the control of the "Foreign Plantations" was

charge of all and occupying the position virtually of a secretary of state for trade. In this way the railway department of the Board of Trade was formed in 1840, the marine department in 1850 and the harbor and finance departments in 1866, all general matters not naturally falling to one of these being dealt with by the headquarters staff, known as the commercial, and since magnified into the commercial, labor and statistical department. During this process of evolution the work of the various departments increased, and is still increasing, enormously. In 1853 the control of lighthouse funds and, to some extent, of pilotage, was lodged with the board, and although in 1872 the negotiation of commercial treaties was transferred to the foreign office further work came to the board by reason of the Bankruptcy Act of 1883.

Among the multifarious duties of the board may be mentioned the collection and issue of trade statistics; the issue of patents and the registration of trademarks and designs; keeping the standards of weights and measures; controlling the non-legal machinery of bankruptcy and registration and supervision of joint stock companies; the general supervision of railway, light railway, tramway, water, gas and electric lighting and power companies and their undertakings; fisheries, docks, harbors and navigable channels; wrecks and quarantine; administration of



ENTRANCE TO RAILWAY TUBULAR BRIDGE AT CONWAY CASTLE.

vide Parliament in matters of trade, it was not till the passing of Cromwell's famous Navigation Act that any department of a permanent character was attempted. At the Restoration, in 1660, a committee of the privy council was appointed for the purpose of obtaining information as to exports and imports and

handed over to the newly constituted office of secretary of state for the colonies and in 1780 the board succumbed to one of Burke's impassioned attacks on the public services. Six years later the first commercial treaty between Britain and another country was entered into with France and the Board of Trade was

the merchant shipping acts and the compulsory examination of master-mariners and mates; regulation of the engagement and discharge of seamen; survey of vessels for certificate of fitness to carry passengers; the measurement of tonnage; detention of unseaworthy vessels; testing and proving of chain cables and anchors; supervision of emigration and immigration, and supervising the Trinity House accounts.

The railway department, of which Col. Sir Herbert Jekyll, K. C. M. G., R. E., is the present head as assistant secretary in charge, has a staff of a chief and three other inspecting officers, together with two assistants and three sub-inspectors, and an electrical expert to advise on matters connected with the employment of electricity on undertakings coming within the purview of the department. The four inspecting officers generally confine themselves to the inspection of new or altered works and the holding of enquiries into such train accidents as have involved loss of life or where great issues are at stake. The services of the two assistant inspectors are retained almost entirely in connection with the enforcement of the railway (prevention of accidents) act of 1900; while the three sub-inspectors enquire into the many smaller accidents incident to the everyday life of the railway world. During the year 1905, the last completed year for which the figures are available, 24 train accidents were inquired into by the inspecting officers and

to the same rules as governed carriers whose only instrument of locomotion was the horse. Railways are, therefore, still amenable to the provisions of the old car-



H. R. H. THE PRINCE OF WALES, NOW EDWARD VII, IS IN THE CENTRE OF THE GROUP.

riers' law, subject, of course, to such amendment as may have resulted from subsequent acts of Parliament. The railways as they now exist are the result of many hundreds of "private" acts of Par-

clearly laid down by the common carriers' act of 1830, close on 250 of these general acts relating to railways have been passed, in addition to many others which by their nature are applicable to railways in common with other commercial undertakings, as, for example, the various factory acts and public health acts. Almost without exception these acts of Parliament have placed powers of control, sometimes slight, mostly far-reaching, in the hands of the Board of Trade.

Under the provisions of these acts the Board of Trade has at various times issued orders involving large works and heavy expenditures, aimed mostly at the adoption of safety appliances and the restriction of hours of labor. The railway companies are also bound to provide the board with certain returns, etc., of which the following are the chief:

One month's notice of intention to open a new line and a second notice ten days before the first expires to allow of examination by an inspecting officer, with sheaves of particulars relating to the construction and equipment of the new line.

Accidents to trains or to railway servants; fatal accidents to be reported within 24 hours of the occurrence.

Cases of "long hours" and "short rest."

Continuous brakes and failures of same.

Failures of a large number of specified locomotive or rolling stock parts or material, such as wheels, axles, tires, boilers, connecting rods, coupling rods, gauge glasses.



OLD VICTORIA TUBULAR BRIDGE OVER THE ST. LAWRENCE AT MONTREAL, CANADA.

Photograph by

Wm. Notman & Son.

789 inquiries were held by the assistant inspectors and sub-inspectors into accidents, other than train accidents, involving fatal or other injury to 804 persons.

Prior to the introduction of railway transport, there was a well-defined system of law relating to carriage by land and, in the eye of the law, the first railway companies were merely a new sort of common carrier, subject consequently

liament, passed at various times, granting the promoters powers to construct and work specified railways, many of which have in course of time been, by means of further similar acts, amalgamated into the larger systems we see to-day. These railways at once became subject to various general enactments specially aimed at their regulation and control. Since the old carriers' law was

Half-yearly accounts and balance sheets in statutory form.

Annual return in statutory form of capital, traffic and working expenses.

Half-yearly return of capital authorized and raised. If, as is the case with most of the large companies, the railway undertakes sea transport or possesses other vessels in connection with its work, a large number of documents have to be

sent in to the marine department. Special returns are often called for, mostly with, but sometimes without, Parliamentary authority, on such matters as hours of labor of certain specified grades of servants, wages, passenger fares, cheap trains, goods rates, mileage run over particular sections, coal conveyed, safety appliances, other means adopted to

in order that a representative of the board may be present to "watch the proceedings." The coroner is given power to cause the place where the accident occurred, and the engine, vehicles or plant, or any other thing which may throw light upon the circumstances of the accident to be left as it was immediately after the accident, unless such

notoriously prone to attach blame for an accident on the employer or other person or persons in position of trust or authority, from sympathetic motives which can be fully understood and appreciated as perfectly natural and honorable. The Board of Trade inspectors, however, charged with the duty of looking for the cause, rather



VICTORIA JUBILEE BRIDGE OVER THE ST. LAWRENCE ON THE PIERS OF THE OLD TUBULAR BRIDGE.

prevent injury to passengers and servants, number of passengers carried during certain hours or by certain trains, types of locomotives used for certain traffic or over certain sections of the line, load capacity of wagons, weight of rails, etc., etc. No difficulty is experienced in obtaining this information, although in many cases it is evident to the companies that it is asked for only with an eye to the possibility of adding yet another to the long list of special enactments by which their operations are controlled.

There are those who seek to impose further restraint on the companies, as, for instance, the cheap tickets bill of 1903, the bills on overcrowding and the time limit on passenger tickets of 1906, the owners' risk rates and the board of conciliation bills of the present session, and the bill, also of this session, to amend the law as to coroners' inquests in the case of fatal accidents on railways. This last may serve as a good example of the spirit which prompts these latter-day proposals of the British Parliament. It provides that in any case of death reportable to the Board of Trade, the coroner shall advise the board by telegraph of the time and place of any inquest he may intend to hold, and shall, if necessary, adjourn the proceedings (taking in his discretion sufficient evidence of identification to enable the body to be interred if desirable)

action would increase or continue a danger or would impede the working of the railway. Subject to the order of the coroner any relative of the deceased and any person appointed by the committee of any trade society of railway servants or of any friendly society of which the deceased was at the time of the accident a member, is to be at liberty to attend and examine any witness either in person or



COUCHANT LION OF THE BRITANNIA BRIDGE.

by legal representative or by a properly accredited agent.

It may be remarked that coroners' juries are, and always have been,

than the effect, of an accident, and pointing out what suggests itself as a remedy, find themselves in the very large majority of cases compelled to lay the blame for an accident either upon the person killed or injured or on some fellow worker; this is especially the case in the many minor accidents to railway servants reported upon by the sub-inspectors. The writer holds no brief for the railway companies, but simply appeals for confirmation to the accident blue books, which year after year tell the same story of gross carelessness leading to injury and, sad to say, sometimes to death.

The conduct of a Board of Trade inquiry into a railway accident, however important or however trivial (and many can only be classed under the latter term), is practically the same in all cases, the length of the inquiry and the prominence given to it by the board varying, of course, with the magnitude of the accident. On receipt of the notice of accident, with the prescribed preliminary particulars, from the company concerned, the company is informed that the board has appointed one of its officers, named, to inquire into the circumstances and that the officer in question will communicate further. An appointment, possibly several, is then fixed for the inquiry, when the company, if requested, arranges for the inspector to be conveyed, often by special train, to the scene of the accident.

Previously all arrangements have been made for the production of witnesses and exhibits. It may be necessary for the inspector to view the spot, to closely examine a portion of the line or some broken or fractured material, sometimes indeed to have material subjected to

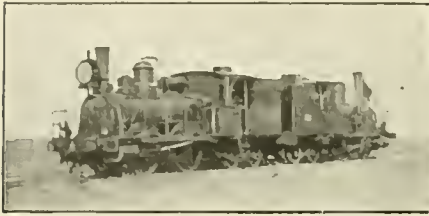

TWO RUSSIAN OIL BURNERS  
MAKE A "TWIN."

lengthened mechanical or chemical examinations or tests. Nothing may be disturbed at a railway wreck except what is actually required to enable traffic to be resumed unless permission is given.

In such cases the whole resources of the company in the desired direction are at the disposal of the inspector; indeed, acknowledgment is frequently made by the officers in their reports of the courtesy shown them and the willing assistance rendered them by the railway officials, all of whom, if in any way connected with the inquiry, are in constant attendance. Witnesses are, of course, not examined on oath; but the inquiry is always keen and searching, and any person with something to conceal invariably has a bad time. Having closed his inquiry, sometimes after adjournment, it is by no means uncommon to find the inspector, in his determination to arrive at a definite and satisfactory conclusion of the case, seeking further information in correspondence. In due course his report is presented to the assistant secretary "for the information of the Board of Trade" and copies are sent to the company concerned, after which, if the circumstances are of public interest, the press is supplied. Every quarter the reports of the inspecting officers and assistant inspectors, with an abridgment of those of the sub-inspectors, are published with copious detailed and summary tables, as a blue book.

A lengthened acquaintance with these blue books enables one to testify to the evident desire, almost without exception successfully achieved, on the part of the inspectors to fulfil their duties impartially and to render their labors fruitful and to render their labors fruitful in the gradual elimination of causes of accident. It is not too much to say that, in conjunction with the efforts, often at large expense, of the companies themselves, voluntarily taking the initiative in providing safety appliances and precautions, the suggestions and recommendations of these officers have been largely instrumental in making the working of the railways of the United Kingdom the wonder and admiration of the world in general.

### Hints on Brazing.

Jobs of brazing have to be done so frequently by workmen not familiar with the proper way of doing the work that we venture to publish a few directions that are likely to be found useful.

In brazing brass, copper, wrought iron and steel, clean the metal thoroughly at and near the joint to be brazed by scraping or filing. Be sure to fit the edges close together. If great strength is required, lap the edges by each other about a quarter of an inch. A good plan is to rivet the edges together to hold them in position.

Next place the brazing material along the joint. Take borax, finely powdered, wet it with clean water and place a small quantity along the seam. Put the article with the joint down, over a forge, having a coal fire. Heat it slowly and evenly, holding it an inch or so above the coal. Hold the article in one hand and a small iron rod in the other.

If the brazing material should be moved away from the joint by the borax, place it back before it melts. When it is all melted, rap the article lightly with the



OIL BURNING FREIGHT, ON THE TRANS-CAUCASIAN RAILWAY.

rod, which will help the brazing material to flow all through the joint. Remove the article from the fire as soon as all the brazing material is melted, and hold it horizontally until it cools, so that it will not run. If the article is brass or copper it should be plunged into cold water, but if steel or iron, it should be allowed to cool slowly. For brazing brass use silver; for copper, iron or steel use spelter or thin strips of sheet brass.

### Boston Elevated Side-Door Cars.

The Boston elevated railway have recently received forty-five new steel passenger coaches, which are fitted with a side door on each side. These doors are 3 ft. 4 in. wide, placed in the middle of the car, and through them the passengers pass out, the end doors being used exclusively as entrances. These side doors are pneumatically operated by the guard. The new cars are 46 ft. 7¼ ins. long over platforms, 8 ft. 7 in. wide, and 9 ft. 5 in. high from the bottom of the sills to the top of the roof.

The seating capacity is forty-eight passengers. The car weighs about 26,-

000 pounds. The underframes are of steel, the center sills being made of 9-in. channels. The side sills are built up of angles and plates. The outline of the side sill follows very closely that of an ordinary truss rod, as the plate used is about 24 ins. deep in the center.

The ends of the cars are provided with what are called anti-telescoping plates at the top of the platform supports. All the posts are made of steel. The corner posts are made of special pressed steel shapes. The pantograph gates which connect the cars together when in a train are made of 1-in. channels. These gates will easily stretch out when the cars swing round a curve of 82 ft. radius, and they readily adjust themselves for change of grade and inequality of motion of the cars.

The only wood used in the car is in the floor mat and in the doors. The cars are considered to be practically fireproof. They were built by the Pressed Steel Car Company of Pittsburgh and are very substantial-looking vehicles.

### Flying Machines.

A number of flying machines were tested at the Alexandra Palace, London, England, under the auspices of the Aero Club last month. Nine competitors presented themselves and the greatest success was achieved by Mr. A. V. Roe. One of his machines flew the full distance of the grounds and landed in the net, the flight being nearly 90 ft. The machine was propelled by twisted rubber. A machine exhibited by Mr. F. W. Howard, after a series of failures, finally made a successful flight of 108 ft. Mr. H. B. Webb's exhibit caused much amusement. Instead of rising in the air, as the designer expected, it commenced to run backwards. It finally rose and flew about ten feet forward and suddenly reversing its flight, flew backward, landing among the spectators. The heaviest machine and most grace-



ENGINE SHED AT BAKU, RUSSIA,  
TRANS-CAUCASIAN RAILWAY.

ful in its flight was designed by Mr. P. Clarke. It covered about 40 ft.

It was not considered by the committee of the Aero Club that any machine merited the first prize of £150. Mr. Roe's device secured the second prize of £75, and Mr. Howard's the third of £25.

### The Human Element.

In our February issue we commented on some correspondence which had appeared in the English press concerning the duty of a doctor. The question raised was, briefly: should a doctor report to the railway the condition of a signalman whom he found to be suffering from heart disease? The physician not being in the company's service, and the signalman being simply one of his regular patients. Opinion was divided as to whether the doctor should or should not report the case. Those who held that he should believed that the life of passengers was endangered by the liability of the signalman to sudden death.

discovery in any such emergency is inevitable at the approach of the first train. As in the case alluded to—the signals not being lowered—the discovery, was made in accordance with the rules, which are mandatory, the engineer being compelled to send the fireman to the box to ascertain the cause. It is a common regulation in Great Britain that no train is sent forward from one box to another until it has been accepted by the man at the advance box. Should anything happen after a train has been so accepted the non-receipt of the signal that the train had passed the advance box, also the non-receipt at the box next ahead of the signal that the train was approaching,

the clamor for high speed is not likely to be yielded to as it has been, and it is to be hoped that a stricter enforcement of the regulations and a continued call for safety will tend to minimize the casualty list attendant upon modern railway traffic.

### Baldwin's New Catalogue.

Record of Recent Construction No. 60, of the Baldwin Locomotive Works, is a finely illustrated pamphlet of thirty-two pages, showing in a terse and yet comprehensive way the growth of the locomotive during the last forty years. The work is enhanced by the reproduction of an able paper by Mr.



HURRAH FOR THE ATLANTIC CITY ROLLERS!

Copyright by the

Detroit Photographic Co.

After the recent railway disasters which have occurred in Great Britain, the public mind, as reflected in the press, seems peculiarly sensitive on the subject of railway safety appliances. More correspondence has occurred on the subject of a dead signalman on the Lancashire and Yorkshire Railway. It appears that as a train pulled up at Blackburn the signals were not lowered for it to proceed, whereupon the engineer sent the fireman to the box to ascertain the cause, and the signalman was found dead at his post.

As far as public safety is concerned where this system is used, there need be no alarm over such a contingency. The safety of trains under such conditions is provided for. An immediate

would lead to the men at both these boxes to ring up the middle man and endeavor to find out why he had failed to send the required signals. This would bring out the facts and his inability to signal would be discovered.

It may be noted that the worst railway disasters in Great Britain of recent times have been largely owing to one cause—an excessively high speed at sharp curves. This practice is likely to be changed after the terrible lessons that have been learned by recent disasters in America as well as in England. The temptation to make up lost time is very great, and repeated risks safely run is but the forerunner of inevitable disaster. At the present time it looks as if

W. P. Evans on the efficiency of a modern locomotive as compared with the lighter locomotives of twenty years ago. Probably the most striking feature in the publication is an interesting statement in regard to the cost of fuels. This is particularly valuable at a time when the oil-burning locomotive is coming into popular favor. Another interesting feature is the illustration and description of the Vauclain superheater. This device is entirely in the smoke-box, and does not in any way lessen the heating surface of the boiler, but utilizes the waste gases for the purpose of superheating the steam. The catalogue will be furnished on application to the office in Philadelphia, Pa.

### Southern Pacific, Atlantic.

The locomotive shown in our illustration is one of eleven 4-4-2 engines recently built by the Baldwin Locomotive Works for the Southern Pacific Company. These engines are made to conform to the common standard adopted by the Associated Lines, and are equipped for burning fuel oil. Locomotives of similar type, but equipped for burning coal, have been built for the Union Pacific System and the Chicago & Alton Railway.

The engine shown is of the single expansion type, with piston valves, actuated by shifting link motion, cylinders 20 ins. in diameter by 28 ins. stroke. The drivers are 81 ins. in diameter and with 200 lbs. steam pressure the tractive power is 23,500 lbs. The weight on the driving-wheels is

to insure good circulation of water, the tubes are spaced with  $\frac{7}{8}$  ins. bridges and the mud ring is made 5 ins. wide all round. Crown bar staying is used, and the longitudinal seams are on the top center line and are of the diamond type. The firebox is provided with what may be called a shallow ash pan suitably arranged, the oil burner being placed in the front end. The heating surface of this engine is in all 2,654.9 sq. ft., of which the tubes contribute 2,375.1 sq. ft. and the firebox 179.8 sq. ft. The tubes number 297 and are 2 ins. outside diameter and 16 ft. long.

The tender is of unusually large capacity for a passenger locomotive. The tank has a water bottom, the oil tank being carried in the fuel space. The capacity of the tank is 9,000 U. S. gallons of water and 2,835 gallons of oil.

that, taking the general average, evaporation of water per pound of petroleum equals about ten pounds. The average evaporation of water with coal fuel equals about six pounds. This shows the evaporative power of petroleum to be nearly double that of coal.

The same care must be exercised as in coal burning to raise the pressure slowly. The firing should never be forced, the filling and choking of the tubes with soot being one of the attendant evils, while the burning of the inner shell and rivet heads cause leaking of the joints and flue ends. In a falling steam pressure care should be taken to raise the pressure slowly to the necessary point. While running, smoke may be prevented by use of the sand blast, the jet being directed above the brick arch. Sanding should be continued lightly as long as the smoking con-

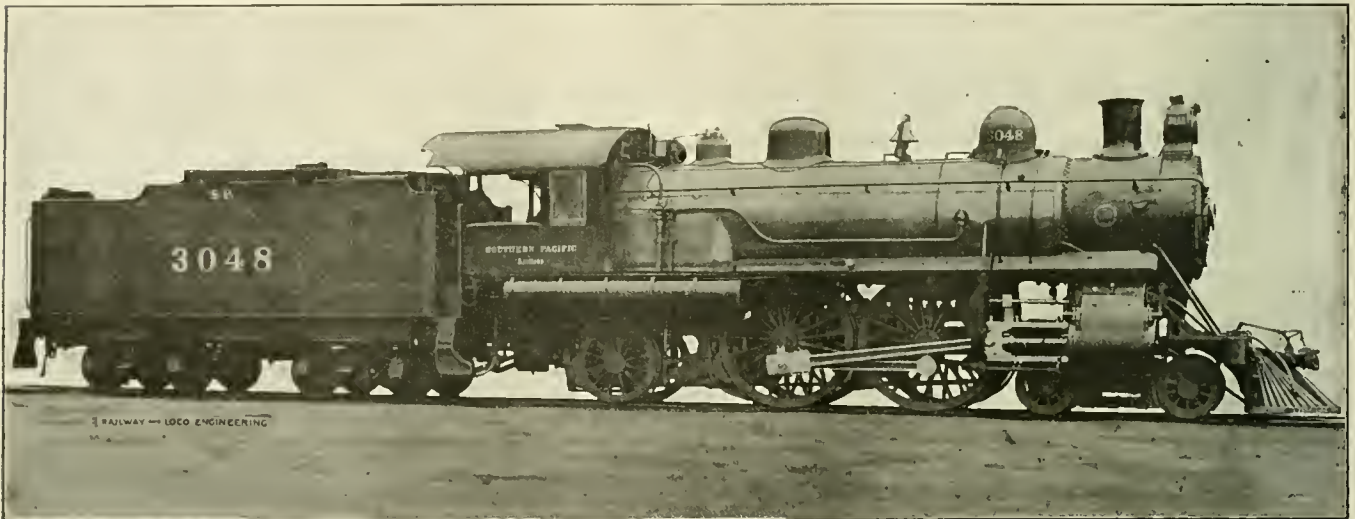

FAST PASSENGER 4-4-2 FOR THE SOUTHERN PACIFIC.

H. J. Small, General Supt. Motive Power.

105,000 lbs., hence the factor of adhesion is 4.46. The weight of the whole machine is 196,000 lbs. and this is distributed so as to bring 45,000 lbs. on the engine truck and 46,000 lbs. on the trailing truck. With tender the total weight is about 323,000 lbs.

The cylinders are fitted with a modification of the Sheedy circulating valve, the seat for which is located in the cylinder casting. The piston valves are 12 ins. in diameter; they are driven by indirect link motion, the rocker being placed in front of the leading driving-wheels and connected with the link by a transmission bar which spans the front axle. As the valve rod is short the upper end of the rocker is provided with a cross-head. The frame has double front rails, the main and trailing sections being in one piece. The trailing wheel is rigid and is equalized with the driving-wheels.

The boiler is straight top, 70 ins. in diameter at the smokebox end, with sloping throat and back head. In order

Some of the principal dimensions are as follows:

Boiler—Thickness of sheets, 11-16 in.; fuel, oil; staying, crown bars.  
 Firebox—Material, steel; length, 108 ins.; width, 66 ins.; depth, front, 68 ins.; back, 64 ins.; thickness of sheets, sides,  $\frac{3}{8}$  in.; back,  $\frac{3}{8}$  in.; crown,  $\frac{3}{8}$  in.; tube,  $\frac{1}{2}$  in.; water space, front, 5 ins.; sides, 5 ins.; back, 5 ins.  
 Driving Wheels—Journals, 9x12 ins.  
 Trailing Wheels—Diameter, 51 ins.; journals, 8x12 ins.  
 Wheel Base—Driving, 7 ft.; rigid, 15 ft. 9 ins.; total engine, 27 ft. 7 ins.; total engine and tender, 58 ft. 2 ins.  
 Tender—Journals, 5 $\frac{1}{2}$ x10 ins.  
 Service—Passenger.

### Oil-Burning Locomotives.

Perfect combustion can be secured with oil-burning engines when an accurate combination of oil and steam is made with the requisite quantity of air. Heating the oil in the tanks is desirable, and this is done by admitting steam into the tanks to warm it sufficiently. It is good practice to heat the oil while the engine is standing. When properly adjusted the mechanism is easily managed, and is becoming very popular on many roads, requiring much less labor than the handling of anthracite. It has been found

Baldwin Locomotive Works, Builders.

It is not considered good practice to put the fire out entirely until the engine has finished its trip. In waiting at stations it is as well to keep the fire burning fairly strong if the injector is working. When the feed is shut off the dampers are closed to prevent an excess of cool air rushing into the firebox and tubes. It need hardly be stated that manholes and ventholes should never be approached with lighted torches, as explosive gases are often being given off by petroleum at the smallest openings. It is usual to measure the depth of the oil when in an open or loosely covered tank by a rod, the wet portion of the rod readily showing the depth of oil in the tank.

In an advertisement by an English railway company of some uncalled-for goods the letter "L" had been by an accident dropped from the word "Lawful," and read thus, "People to whom these packages are directed are requested to come forward and pay the awful charges on the same."



# General Correspondence

## Ton-Mile-Per-Hour.

Editor:

Mark Twain, after closely sifting statistics, found while reviewing civilized humanity as a whole that more people died in bed than were killed in accidents or fatalities of all kinds. He, therefore, illogically but humorously makes the deduction that bed is a good place to avoid if you wish to live long. If railway companies seriously desire the economy of fuel, it can probably be shown that to save coal the side track is a good place to avoid.

It can easily be proved that the ton-mile-per-hour is the only fair method of rating the performance of an engine, because it takes into account the speed attained. If an engine covers one division on any road in a given time it makes a certain number of ton-miles-per-hour. If another engine runs the same distance, with equal load, in less time and burns more coal, it makes more ton-miles-per-hour. The mere ton-miles for the trip are equal in both cases, but the coal burned is not.

The whole question of fair rating of locomotive performance lies in finding some equivalent which increases as the work done increases and therefore increases as the amount of coal burned increases. Some rational equation must necessarily subsist between work done and coal used. That the car-mile was most grossly misleading and utterly useless goes without saying. The ton-mile, though better, falls short, unless the element of time be included.

It can be shown that if two trains of equal weight, pulled by equal engines, run over the same division of any road in a given direction, under identical conditions, one in less time than the other, the faster of the two will burn more coal, but will stand equal to the other in economical performance.

Let A and B be two engines, on any road, equal as regards condition, cylinders, boiler pressure, size of wheel, tractive force and skill of crews, each pulling equal trains over same division, in same direction, under identical conditions, but B traveling faster than A. Let A make 120 miles with 360 tons load in 3 hours and let B make same mileage with same load in 2 hours and 40 minutes. Then A will make 43,200 simple ton-miles in the trip. So also will B, and both will be equal, each to each, in the matter of total ton-miles—or even car-miles, for that matter—during the trip. The perform-

ance is said to be equal but it probably is not as far as coal burned goes, because E has burned more coal than A for the trip. But A and B are equal in performance by the ton-mile-per-hour. A has made 14,400 ton-miles-per-hour and has burned  $x$  tons of coal. B has made

is hardly any one who would maintain that the performance of each was equal. Yet both passed through the same space and were both acted upon by the same force of gravity, supposing both to be equal in size and weight. On nine railways out of ten both would be considered



"WE HAD COAL TO BURN AND STEAM TO BLOW AWAY ALL THE TRIP."

(Copyright by the Buffalo Express.)

16,200 ton-miles-per-hour and has burned  $x + y$  tons of coal. For sake of example, suppose 14,200 divided by  $x$  equals 16,200 divided by  $x + y$  tons of coal. Therefore, A equals B in the matter of performance when the ton-mile-per-hour is used, as it should be.

If two men go up a couple of thousand feet in a balloon, and one jumped out at that height and the other came down with the aid of a parachute, there

equal in performance and so stated on the monthly sheet, though one came down in seconds while the other occupied minutes to make the same journey.

If one engine burns more coal than another there is some reason for it. If both engines are in the same condition, with dampers, draft appliances, steaming qualities, men fairly equal, the difference for equal trains and conditions will very probably be due to different speeds of

travel. If it be found by experiment that the difference in coal consumption is due to inequality of speed, then fairness demands that the time element be introduced into the method of solving the problem.

The ton-mile-per-hour has, however, an-

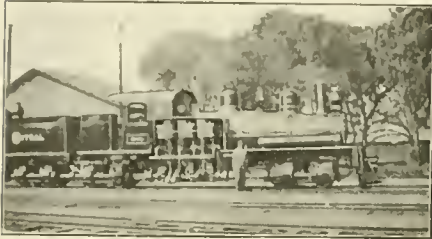

SIXTY-FIVE TON "SHAY."

other advantage. It brings out the side-tracking of an engine in the most unmistakably vivid colors. One cannot use the ton-mile-per-hour consistently and throw in several hours of detention, as time used by the engine in pulling its load. The engine does no work while it stands still, though it burns coal and costs money. It is this coal and this cost which the mechanical department has a perfect right to say has nothing to do with performance.

If an engine stands still half-an-hour on the road and burns coal it may be that the detention is due to a bad "crossing." If so, the Operating Department is responsible. If this thirty minutes is due to a hot driving box the Mechanical Department must shoulder the lost time. If due to a hot box on a car, then the Car Department must explain. Now, if the half-hour so lost is deducted from the running time, the performance of the engine taken under the ton-mile-per-hour idea is the thing to work with. All detention on a trip may be summed up. Experiments made with standing engines will give an average rate of coal consumption, and when translated into its money equivalent, the dollar and cent value of the detention can then be shown against the department properly responsible. As it is now, when this amount is thrown into the performance column, the Mechanical Department is expected to explain the poor and wrong result; and not having the power to remedy the evil, must grin and bear it while the service suffers.

An engine is often wanted for a special train on very short notice, and the Round House staff hears of it for being a few minutes behind time. Has not the Round House seen the same engine, attached to a train and badly side-tracked, fifteen miles out, on a miscalculated crossing?

The ton-mile-per-hour, however, takes no notice of side-tracks. It leaves them to the people to whom they belong. It faithfully gives the performance, in terms of coal used, with its money value, of the moving engine, whether it be late or early,

fast or slow. It records what the engine does in haulage. The Operating Department rather enjoys a good hot box engine, when it comes to accounting for detention, for hot boxes, like Charity, may be made to cover a multitude of sins; but with the ton-mile-per-hour to say how the work was done there could be no covering it over with the blanket off the Mechanical Department bed. That Department would, if once fairly relieved of the deadly side-track, know where its engines properly ranked and would have some definite and reliable data to go on. Detention could be given a separate column on the performance sheet, and switching along the road might be called so in a separate column on the performance sheet. It would have a definite amount of coal per hour allowed, found by its experiment, and its cost fairly reckoned, but it would not touch the performance of the hauling, moving engine as it tugs at its load up hill and down dale. The ton-mile-per-hour knows nothing which is not straight haulage all through. It is a piecework price set for an engine; and no amount of switching or hot boxing or bad crossing can alter the output of the engine at work hauling, as gauged by the ton-mile-per-hour.

G. H. WINDSOR.

New York, N. Y.

#### Spring Floods at Bridgeport.

Editor:

I enclose you some pictures of the flood which swept over this part of the country in March, 1907. Picture No. 1 shows the B. & O. (C., L. & W.) roundhouse, also the sandhouse, oil room and engineer's room. The oil house was nearly submerged, all but the headlight used for illuminating the yard. The engineer's room is leaning



B. & O. WRECKING TRAIN CAUGHT BY THE FLOOD.

over ready to fall, and the sandhouse is half under water. The water rose about 8 ins. higher than appears on the picture, which was taken at 2 P. M. on the 15th of March. The water was 50 ft. 2 ins. high at 9 P. M. on the same day.

No. 2 shows the B. & O. wrecking

train "sewed up." It is the Bentwood wreck train caught on the C. & P. transfer. Owing to the delay in getting orders over the C. & P. track to Bellaire, this train was caught.

Thinking these pictures may interest your readers, I have pleasure in send-



B. & O. ROUNDHOUSE FLOODED.

ing them to you, although according to some people, floods are ancient history since Noah's time.

JOHN W. GRAYBILL.

Bridgeport, Ohio.

#### Early Locomotive Builders.

Editor:

I noticed a list of those that had built locomotives in the past given in your issue of May, 1906. I remember most of those in New England. I think the Mason and the Taunton were both built at Taunton, Mass. There were locomotives built at the Ballardvale machine works, Ballardvale, Mass. They only built three, so I have been informed, two for the Boston & Maine, the "Boston" and the "Ballardvale." Their road numbers were 14 and 15 and all three were insiders. The other was built for the old Portland and Kennebeck road (now a part of the Maine Central system) and was named "Topsham," I think.

There were also locomotives built at the Amosberg machine shop at Manchester, N. H. They built mostly outsiders and were the pioneers for style and neatness at that time (the last of the fifties). The Concord road had several and they were beauties. In my mind, I see them now, as when a boy; there was the "James Haywood" and the "Josiah Stickney" and the "E. J. M. Hale" and the "John Kimble." The E. J. M. Hale was sold to the government in war times and went to North Carolina. The John Kimble ran into a washout and killed her engineer and fireman, and was afterwards rebuilt and named the "B. A. Kimball," after the M. M., I think.

I also remember an insider built at this latter shop for the B. & M. It was named "O. W. Bailey." When completed it was taken to the roundhouse of the Manchester & Lawrence R. R., and a picked crew and a number of friends of the Amoskeag com-

pany, were going to run her to Lawrence the next day. As the setting up crew had been slighted in regard to invitations they thought they would "steal a march" on the others and take the chances afterwards of losing their jobs, so they deceived the watchman



THE 4-6-0 ENGINES.

at the enginehouse and got her warm and out on the main line and ran her to Lawrence into the B. & M. roundhouse where it was accepted by the latter company. They did not know the road very well and used up most of the night getting 28 miles. Some of those connected with the above circumstances may yet be alive and can give it in detail. If so, I would like to hear from them through the columns of RAILWAY AND LOCOMOTIVE ENGINEERING. The gay deceivers did not lose their jobs. LEVI L. FLETCHER.

*West Buxton, Me.*

**The Passing of the Old-Time Dummy.**  
Editor:

At Mt. Lookout, near Cincinnati, there has passed before the advancing tractions one of the last of the curious steam railways, which, for want of a better name, were dubbed "dummies."

The "dummy" was rather in a class by itself. Basically it was a car, rather the shape of the old-style railway cars, but was considerably broader and without platform at one end. One end then was given over to the engines. These were simple, plain steam



SOME MORE 4-6-0 ENGINES.

engines of the sort needed to propel the car. They were cramped, or, rather, it was the style that the engineer's portion of the car should occupy the minimum of space. Grades were fairly easy, and there was no particular striving after speed.

The fore half, or, better, three-quarters of the car, held the passengers.

Just a bench of plainest wood along either side with an aisle down the middle. At the farther end was the platform where the conductor had his place. When he was sick or off duty the engineer collected fares. The stations were just sheds, as a sort of shelter in bad weather, along the route, from the city to the outlying suburbs. Most of the traffic came from sight-seers, visiting the university observatory on the two nights of each week when strangers were shown the skies.

Often as not you got to the end of the street car line to find that the "dummy" wasn't running. Then you either had to walk or else give up the trip. It was awfully cold in that car, despite the stove they put up in it.

**Facts About the Guatemala Central.**  
Editor:

As this is "Good Friday" and a convenient time for me to improve the opportunity of replying to your esteemed favor in which you requested me, when I could find time, to contribute a few lines to your columns, giving your readers a little information relative to our road, its power and equipment, I now comply with your request, as there won't be a more quiet time in the year than the present, for, as you possibly know, this is one of the greatest "Church Fiestas" of the year. On this day no native will work, hence the shops are closed, and business on the road practically suspended, and will remain so till after Easter.



THE "DUMMY" AND THE WAYSIDE STATION.  
(Photo by C. A. Kraemer.)

But who cared? It was primitive and picturesque, and all a phase of the jaunt to the observatory! Most persons made such a trip but once in their lives, so they could stand it, if the others could.

Then, too, they were accommodating on the dummy. If, for some reason, a party was delayed they would wait until the last straggler had come in. In fact, people came to love the sturdy old creature and hated to see it go, much as they welcomed the electrics. Nothing was too good for the memory of the dummy. The old cars of the line were taken to a point on Mt. Lookout and given public cremation. There is even talk of a monument being put up on the site of the ashes' interment, but as yet this has not come.

FELIX J. KOCH.  
*Cincinnati, Ohio.*

Only the regular trains run, the whistles are not blown, no bells rang, church bells are silent in the city, no street cars run, and in fact, no vehicles of any kind are seen on the streets, as this is truly a day of rest for the "animal servant," as well as for the people in general.

Our road comprises 145 miles of well ballasted track, 54 pound rail, iron bridges, gauge of track 3 ft. The line runs from San Jose, the Pacific port, 75 miles to Guatemala City, and rises to an elevation of 5,000 ft.; another line of 60 miles parallels the coast. This is comparatively level, and passes through the best coffee and cane section of the country. There is also 10 miles of branch lines.

Our power consists of 25 engines of the following classes: Four small 4-4-0, thirteen 4-6-0, four 2-8-0, three

2-6-0, and one 65-ton "Shay." The latter is in mountain service. The fuel is wood and imported coal. Our company is now making extensive preparations to use "fuel oil," and expect to convert the engines into oil burners within the present year, the storage tanks are now ready to receive the first shipment of oil. The equipment for burning oil is similar to that used on the Southern Pacific. The burner is the patent of W. H. Russell, N. M. of So. Pac. road at Oakland, Cal. Our engines are mostly "Baldwins," and the 4-6-0 class are the largest narrow

Ass't. M. C. B. on the left, and on the right is Mr. Collins, our shop clerk, who is also your club agent here. At

coffee planters in bringing their produce to the road.

With a few words more to explain the last picture I will close. This is a new and modern station building, located at San Jose, directly at the end of the pier. It is a well arranged terminal. Passengers coming from the steamers pass through it to their trains. Freight is hauled from end of pier on small cars and placed in the station alongside of railroad cars, where it is transferred. The upper part of the building is the office of Mr. Savage and his army of clerks. I



GUATEMALA CENTRAL SHOPS.

present he is doing a rustling business for your publication, having 30 subscribers among our officials, engineers and shop men.

The car equipment comprises 500 cars as follows: 58 coaches and baggage, 452 box, stock, flat, combination, refrigerator, steam shovel and derrick cars. We are now receiving the Climax automatic couplers for equipping all the cars and engines. All cars are equipped with automatic air brake. We



GUATEMALA CENTRAL ROUNDHOUSE.

will quote an old saying in closing, which is, "What everybody says must be so," and "Everybody says" that we have the "best equipped and best managed road south of the Rio Grande River."

W. S. TEMPLETON,  
Supt. M. P. & E.

*Guatemala City, Guatemala.*

**Power of Organization.**

Editor:

Your editorial of March, headed "Power of Organization," we have read



STANDARD BOX CAR.



THE 2-8-0 CLASS.

gauge engines built, being 17 ins. by 20 ins. cylinders, and weighing 85 tons in working order.

For our shops I can say that we have a well equipped and up-to-date plant. Machine, boiler and blacksmith shops are in the main building in foreground. Car and paint shops are in the building directly in rear of the machine shop; the offices and air brake instruction room occupy the small building at left of picture of the shops. The machine shop is well equipped with all necessary machinery, principally of

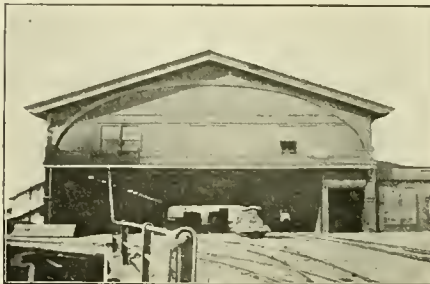

SAN JOSE STATION.

are now beginning the building of 50 more of the 40,000-lb. capacity box cars. These are principally for the coffee trade, which increases annually.

I am sending you a picture of a bridge we recently built at our shops, made entirely out of old rails, drilled and riveted together. This was the idea of our general manager, and designed by Mr. Gray. Two bridges of this size were made and they proved



THE 2-6-0 CLASS.

Niles-Bement-Pond Co.'s make. We have recently added a Hartz flue welding and cutting machine and a Franklin air compressor, using air tools in boiler work, and other repairs. The car shop is well supplied with labor saving machinery, some recent tools being purchased from the J. A. Fay & Egan Co. In front of these shops is a heavy transfer table for handling cars in and out of shops.

In the past year there were 50 new 40,000-lb. capacity box cars built here, I enclose a picture of the last one. You will notice that they are quite up-to-date in appearance, lettering and size. In the foreground is seen our



BRIDGE MADE OF OLD RAILS.

to be cheap and substantial. They were placed on cart roads leading to our stations for convenience of the

and, with few exceptions, heartily agree with you. If the railroad corporations should be met with a solid front of organized labor the matter of contention would have long since been settled and the corporations have long since realized this fact and have used many ways to keep from having to meet this solid front. We will acknowledge that the contest between the Brotherhood of Locomotive Engineers and these corporations has been very successful in the past, but we do not see why the machinists, blacksmiths or boiler-makers should take them as a criterion by which they should go. We will admit that the contests that came of years gone by with railroad

companies and the locomotive engineers did not teach these corporations that they were not dealing with an organization that could be subdued by taking them by the fore-top and leading them to the trough and then force them to drink.

The writer was a young engineer of, possibly, two years' experience as a locomotive engineer at the time of the great C., B. & Q. strike, and was running an engine on a road that paralleled the Western lines in Nebraska and was personally acquainted with many of the engineers; and my engine watchman, who learned to handle an engine under me, left me on a very bad night and the next I saw of him, he was racing along side of me not more than twenty feet away on a big Manchester passenger engine, and as I understand is, today, doing the same thing, and the brother that gave up that fine run and engine for the good of all engineers is now an old man, past the age limit of these corporations, but they allow him to inspect engines at a little terminal on another line for twenty cents an hour.

I bring this out to show you that, while the B. of L. E. is a good teacher, and we have profited much by their lessons, they are by no means any part of an example of perfection, for no other reason than they did not take care of those good brothers that gave up good positions in the business they were in that others might profit thereby. But when it came to getting another position, how was it? First, there was the age limit, that he had to get over some way or other; next, he was a "Q." striker, on many railroads a very serious objection; but if he got over these, there was the seniority clause in the contracts which held him down, no matter how able a man he was, and if he was above the average as a locomotive engineer and intellectually, he would be discriminated against by those of whom he was the actual cause by which they might have a contract and a reasonable wage scale. Do you find that among the machinists, blacksmiths and boiler-makers? No, a machinist with the knowledge, if he be twenty-five or sixty years of age, gets just as good a reception as any one; if unfortunate, and can give a just cause, he will be taken care of, and if he goes to work he will get just as much as any other machinist, blacksmith or boiler-maker in his district, or as much as the road pays. There may be any amount of planers in the shop in which he goes to work and three times as many men competent and able to run them on other work not nearly so agreeable, and they hire a new man and give him the planer job. You would not know within a week but what he had run that planer for years, if you were not aware of the fact that he had not.

There is still another reason why we should not use them as a criterion. We

will show, or make an effort to show, you at once that the I. A. of M. does not do such things as that, and I can prove to you that they do not. While we have a great many disloyal, many bad men and many that are on the beat, we have them pretty well centralized at present and our strikers fairly well taken care of. Every effort is made to help them and they are met oftener with the "glad hand" than the outside boomer, who goes from place to place to see what he can and learn what he may. We will, therefore, make ourselves satisfied with the example we are preparing for ourselves without any ill will to the B. of L. E. or B. L. F. & E.

The writer served his allotted time as a machinist under good time mechanics, fired a reasonable length of time and was

the stand the B. of L. E. does to better our condition.

Enclosed is the photograph of the first engine I ran as a locomotive engineer. The fireman, brother in many ways, John Kennington, is standing on the running board. The gentleman at the left is Daniel Bennington, at that time night hostler; the next one to the left is Mr. John Fulton, the round-house foreman; the next is Mr. Jas. Munday, foreman of the car department; the other two are the conductor, Mr. Richard Utt, and the caller, whose name I do not remember, all of Greenleaf, Kansas, on the Central Branch Railroad.

Many of your readers will recognize this old engine. At the time it was taken the Missouri Pacific had recently absorbed this road and I was sent from



OLD TIMER ON THE CENTRAL BRANCH RAILWAY, NOW PART OF THE MISSOURI PACIFIC.

promoted to the sublime position of locomotive engineer and served as such for a period of more than sixteen years; belonged to the B. of L. E. and B. of L. F. and last, but not least, to the I. A. of M.; have run engines in all classes of service and have made an effort to keep up-to-date on the locomotive and its appliances and now have charge of air brake, electric headlight and the parasites attached to each. While we are glad at this time to command as good wages as any other machinist in the shop, after our long and varied experience with others, we have no desire to do anything that would mar the pleasures of our old brothers in either order. As a locomotive engineer, we consider ourselves a success, with many thanks to the helping hands extended to us. We have been a reader of THE RAILWAY AND LOCOMOTIVE ENGINEERING since its start, or shortly afterwards, but think that we would be away back in style if we would take

Atchison, Kans., to take charge of her, and I may say, I was just about as proud of my position as one could imagine. Many on the Cotton Belt, the C. G. W., the Rock Island and the Santa Fe will recognize your humble servant, but still we cannot see our way clearly by walking in the footsteps of the B. of L. E. or B. of L. F. & E., but see no reason why we should not meet them on any ground for the betterment of their condition, as well as our own, as we are doing very well, thank you.

J. N. HUGHES.

*Air Brake Frisco Shops, Monett, Mo.*

#### Cowlairs Incline.

Editor:

In reply to your letter of 26th ultimo, I have to state that the practice of assisting trains up the Cowlairs incline is still in use and the method consists essentially of a winding engine placed at the

top of the incline driving an endless rope which is idle on the down road. The rope is only in motion when a train is being brought up, and the method of attaching the train to the rope is to use a chain sling with a ring in the middle of it, and having on each end a length of manila rope. The manila ends are tied to the steel cable with the chain sling loose. The ring is placed in the drawhook of the engine which is inverted, and the train slackened back to put tension on the rope. The cable is then started by a telegraphic signal to the engineman at the top of the incline, and release from the cable is obtained whenever the speed of the train exceeds the speed of the rope, as the ring on the chain sling simply drops out of the hook. For controlling downward trains heavy brake

**New Mail Vans, S. E. & C. Ry.**  
The photograph reproduced here shows two new sorting vans for the continental postal services on the South-Eastern and

by counterbalances, runs from the cliffs over the surf railway to the vessels. When the tower gets out to the ship with its load of ore it is about even with

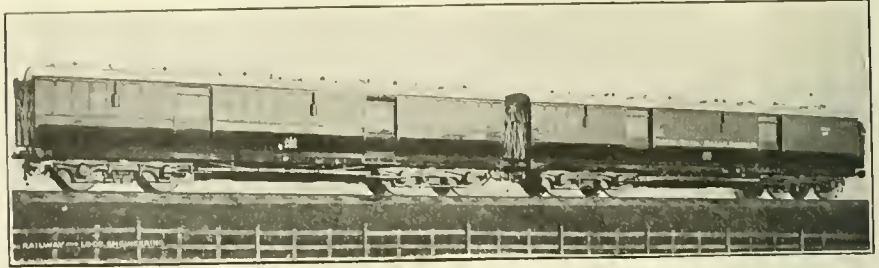

ENGLISH MAIL VANS, SOUTH-EASTERN AND CHATHAM.

Chatham Railway. They are 50 ft. long, with vestibuled ends, and run on pressed steel frames and bogies.

the vessel's deck. As soon as the iron is loaded on to the ship the weight of the counterbalances pulls the tower back



ALL STEEL PASSENGER COACH BUILT BY THE PRESSED STEEL CAR COMPANY, EQUIPPED WITH BUHOUP 3-STEM COUPLERS AND BUHOUP VESTIBULES.

wagons are used, as generally the locomotives do not descend with the trains.  
W. P. REID,  
Supt. North British Railway.  
*Cowlairs Works, Glasgow.*

**Surf Railway.**

Spain is said to have a railway which runs through the surf. It is near Bilbao, and runs 650 ft. out into the ocean. The mines of Oretón are extremely

to the cliff, where it runs up to a chute and automatically opens its mouth. The chute comes down from the mines and, when it has dropped ore enough on the tower to overcome the weight of the counterbalance, the tower moves toward the ship. All that is necessary to do to start the tower on its way and put the surf railway in operation is for the miners to drop a sufficient weight of ore into the chute.



STEEL POSTAL CAR ON THE PENNSYLVANIA.

It's necessary for you to make an effort, and perhaps a very great and painful effort, which you are not disposed to make; but this is a world of effort.—*Dombey & Son.*

rich in iron, but there is no harbor there, and great difficulty has been experienced in getting ore to ships. The railroad runs out into deep water, and an iron tower 70 ft. high, worked

An old farmer residing some miles up the country decided on enlarging his sphere of operations and sent one of his men, who happened to be a new hand, with a wagon to the station to fetch a hen coop that was expected to arrive. The man saw a small wooden structure and after lifting it on his wagon started for home. On the way he met a man in uniform with the words "Station Agent" on his cap.

"Say, hold on there. What have you got there?"

"Why the boss' new chicken house, of course," was the reply.

"Chicken house, be jiggered," exclaimed the railway official; "that's the station!"

**C. & N. W. Ten-Wheeler.**

Thirty engines of the 4-6-0, or ten-wheel type, have recently been delivered by the American Locomotive Company to the Chicago & North-Western Railway. These engines have just recently been turned out of the Schenectady shops by the builders. Five out of the thirty engines have been equipped with the Walschaerts valve gear, the rest have the familiar shifting link motion. Our illustration shows one of the five with the Walschaerts gear.

These engines are intended for general freight service. The cylinders are simple being 21 x 26 ins. and the driving wheels are 63 ins. in diameter. The steam pressure is 200 lbs. per square inch, and the calculated tractive effort of these engines is 30,000 lbs. The

ers have driving box equalizers and the trailing spring consists of a double elliptic spring 24 ins. centers.

The boiler is of the extension wagon-top type with first ring 66 $\frac{3}{4}$  ins. outside diameter. The total heating surface of the boiler is 2,959.19 sq. ft. and this is made up of 150.79 sq. ft. in the fire box and 2,808.19 in the tubes, of which there are 377 each 2 ins. diameter and 16 ft. long.

Another interesting feature in this design is the use of corrugated firebox side sheets. The side sheets are provided with a series of vertical corrugations throughout the length of the sheet to within the last three rows of staybolts at the front and back end, making a waved sheet. The staybolts are located at the top of the waves or in that portion of the sheet which is

crown sheet slopes to the rear. The firebox door is made with a bulge of 2 $\frac{3}{4}$  ins. radius on the inner sheet, so that all round the door the water space has a maximum width of 6 $\frac{3}{4}$  ins.

The weight of this engine in working order is about 179,500 lbs. That of the engine and tender is 319,000 lbs. The tender has a water bottom with gravity fuel slide. The frame is made of 13-in. channels. The tank capacity is 7,500 U. S. gallons of water and 10 tons of bituminous coal. Some of the principal ratios and dimensions of these engines are as follows:

Firebox heating surface	= (in per cent.) 5.37
Tube heating surface	
Total heating surface	= 64
Grate area	
Weight on drivers	= 48
Total heating surface	
Volume of cylinders, 10.40 cubic feet.	



CHICAGO &amp; NORTH-WESTERN TEN-WHEELER.

Robert Quayle, Supt. Motive Power and Machy.

American Locomotive Company, Builders.

factor of adhesion is 4.37. The valves are of the built up piston type 11 ins. in diameter.

The half-tone shows clearly the application of the valve gear, which differs from any arrangement used on previous locomotives built by the American Locomotive Company. The link is supported in a steel casting bolted to the end of the cross-tie or yoke placed between the front and middle pair of driving wheels and extending beyond the driving wheels. Connecting this cross-tie and the guide yoke and outside of the driving wheels is a steel plate 1 $\frac{1}{4}$  ins. thick and 10 ins. deep. The reversing shaft bearing is bolted to the top of this plate just back of the center of the forward driving wheels, and the backward extending arm of the reverse shaft is connected to the radius bar by means of a lifting link. All the wheels are flanged and the driving springs over the main and forward driving wheels are overhung. The back pair of driv-

ing wheels are furthest from the fire. It is a well known fact that the expansion and contraction that takes place in the firebox, due to changes of temperature, causes cracking of the sheets, and it is claimed that in this arrangement the corrugations afford sufficient elasticity to overcome these strains, which finally result in the rupture of the sheet. Moreover, in the ordinary flat plate the heads of the staybolts project beyond the face of the plate so that they are probably more highly heated than the plate itself. With the arrangement used in these C. & N. W. engines, the head of the bolt is somewhat protected from the fire so that the plate and the head of the bolt are more uniformly heated. This style of firebox has been used on the Chicago & North-Western for several years with very satisfactory results. The firebox is 102 $\frac{3}{8}$  ins. long by 65 $\frac{1}{4}$  ins. wide, and has a 4-in. water space all round. The crown staying is radial. The roof sheet is level while the

Heating surface	= 284
Volume of cylinders	
Grate area	= 4.45
Volume of cylinders	
Wheel Base—Driving, 14 ft. 10 ins.; total, 25 ft. 10 ins.; total, engine and tender, 57 ft. 9 ins.	
Grate Area—46.27 sq. ft.	
Axes—Driving journals, main, 9x12 $\frac{1}{2}$ ins.; others, 8 $\frac{1}{2}$ x12 $\frac{1}{2}$ ins.; engine truck journals, diameter, 6 ins.; length, 10 $\frac{1}{2}$ ins.; tender truck journals, diameter, 5 $\frac{1}{2}$ ins.; length, 10 ins.	
Firebox—Thickness of crown, $\frac{3}{8}$ in.; tube, $\frac{1}{2}$ in.; sides, $\frac{3}{8}$ in.; back, $\frac{3}{8}$ in.	
Air Pump—9 $\frac{1}{2}$ ins., left side, 2 reservoirs, 18 $\frac{1}{2}$ x134 ins.	
Engine Truck—Four-wheel swing bolster W. I. frame.	
Grate—Style, rocking.	
Piston—Rod diameter, 3 $\frac{1}{2}$ ins.	
Valves—Travel, 5 $\frac{3}{4}$ ins.; steam lap, 1 in.; ex. clearance, 1/16 in.; 3/16 in. constant lead with Walschaerts gear.	
Setting—Line and line full gear F. & B. with shifting link.	
Wheels—Driving, material, main, cast steel; engine truck, diameter, 30 in.; tender truck, diameter, 33 ins.	

It is chiefly through books that we enjoy intercourse with superior minds, and those invaluable means of communication are in the reach of all.—W. E. Channing.

# Railway and Locomotive Engineering

A Practical Journal of Railway Motive Power and Rolling Stock.

Published Monthly by

**ANGUS SINCLAIR CO.**

136 Liberty Street, New York.

Telephone, 984 Cortlandt.

Cable Address, "Loceng," N. Y.

Glasgow, "Locauto."

**Business Department:**

ANGUS SINCLAIR, President  
JAMES KENNEDY, Vice-President.  
JAMES R. PATERSON, Sec'y and Treas.

**Editorial Department:**

ANGUS SINCLAIR, Editor.  
GEO. S. HODGINS,  
JAMES KENNEDY,  
J. P. KELLY,  
CLARENCE RENSHAW, } Associate Editors.

**Advertising Department:**

Eastern Representative, S. I. CARPENTER, 170  
Summer St., Boston, Mass.

**British Representative:**

THE LOCOMOTIVE PUBLISHING CO., Ltd.,  
Amen Corner, Paternoster Row, London, E. C.

**Glasgow Representative:**

A. F. SINCLAIR, 15 Manor Road, Bellahouston,  
Glasgow.

**SUBSCRIPTION PRICE.**

\$2.00 per year, \$1.00 for six months, postage paid in the United States, Canada and Mexico. For other parts of the world, \$2.50, or ten shillings. Single copies, 20 cents. Remit by Express Money Order, Draft, Post Office Order or Registered Letter.

Mailing address can be changed as often as necessary—always give old and new address, and if you subscribe in a club, state who got it up. Please give prompt notice when your paper fails to reach you properly.

Entered at the Post Office, New York, as Second-class mail matter.

Copyright by Angus Sinclair Co., 1907.

For Sale by Newsdealers Everywhere.

## British Board of Trade.

In another column of this issue will be found a contributed article on the British Board of Trade, its powers and its functions. The article is well worth the careful perusal of everyone who desires to know something of this interesting and important organization.

The British Board of Trade is a department of government, just as much as the treasury or any other of the organized divisions of the government. It does not in any way resemble the various chambers of commerce which are to be found in many of the larger cities, both here and across the water.

The head of the British Board of Trade is Mr. David Lloyd-George and he is a member of the cabinet and has a seat in the House of Commons. He is therefore an elected member of Parliament and as such is a representative of the people.

It has been said that the British Isles are practically governed by a committee of the House of Commons, generally called the government. This committee can be turned out of office by a majority vote of the House at any time and for any reason. The

premier is practically the chairman of this committee.

The railway department of the Board of Trade is charged with the inspection of new lines of railway before they can be used for the transportation of passengers or merchandise. The railway and its equipment must prove satisfactory and be in conformity to statutory requirements before it can be operated.

Perhaps the most widely known function of the railway department of the Board of Trade is the investigation of accidents and the placing of responsibility and the prescribing of remedies where such are deemed necessary. In the inspecting of new lines and in the investigating of accidents the department is engaged in carrying out the will of the people as embodied in law. Questions may be asked in Parliament which it is Mr. Lloyd-George's duty to answer. In any case the report of the investigators is made to the government which through Parliament gives the result to the public.

The obliteration of evidence by a railway company in case of accident, even for the purpose of clearing the line, is not permitted, and any attempt to do so, even if successful, would lay the company open to the serious imputation that they had something to conceal.

The advantages derived by the Board of Trade investigations are that causes are looked for by a trained and competent authority, and one which from the nature of the case is not dependent in any way upon the favor of the railway. The impartiality of the Board of Trade is never questioned, and the fullest publicity for all facts brought to light is one of the greatest safeguards of the whole system.

## Am I My Brother's Keeper?

Among the multitudinous associations of men that blossom into being in great cities, it is comforting to observe that some of them sensibly turn their attention to the safeguarding of human life and the encouragement and the development of safety devices. It would be idle to imagine that this is something new. State Legislatures have added enactment to enactment, but between the law itself and its administration there is a world where the under dog has a hard time to get his rights.

Through the efforts of the men who have directly interested themselves in safety appliances, a museum is being established in New York where devices of every description calculated to reduce the liability to accident on railways, in mines, in buildings and other works where large bodies of men are employed, are to be permanently exhibited. A committee is at work devising means to deal with the

invention of such devices and to broaden the aim and scope of the association. The committee embraces men prominent in every walk of life, and the officials of the organization already engaged in the work are men of wide experience and eminently qualified for the positions for which they have been selected.

In the matter of railways it will be generally admitted that the annual appalling loss of life is a scandal to our boasted civilization. That much of this loss could have been prevented need not be argued. An illustration occurs to us as being immediately near our personal observation. The facts were brought out at one of the meetings of this committee. When the electrification of a portion of one of our large railway systems began its operations for the first month were marked with heavy loss of life. Two young mechanical engineers on their own initiative began looking for safety devices. They searched everywhere for whistles and other alarms and found several to suit their purpose. Whistles with peculiar notes were thereafter used, and the workmen were instructed that one blast meant that a train was approaching on track number one, two blasts meant track number two, and so on. The result was that the number of men killed was greatly reduced during the second month, and during the third month no lives were lost.

While this story has its bright side, it also has its grimly dark side, because it must be remembered that while we talk so lightly of loss of life as if it were the leak from an oil tank to be reduced or happily stopped altogether, it is the very breath of the whole universe, as we know it, to the one stricken down. The safety of others should be the very first thing thought of and not absolutely the last thing to engage the attention of men who are endowed with the brains to think and the will to act in the carrying out of great enterprises.

Ample provision had been made to supply "tools" of every necessary kind. The safety of the workmen seemed never to have been even considered until the ghastly spectacle of maimed and mangled bodies suggested to the minds of some of the less hardened officials the possibility of reducing the number of casualties. The remedy was simple enough, and might have been thought of before, but it is a singular fact that in the launching of great enterprises there is practically little or no thought given to the safety of human life.

If an association of the kind that we have alluded to could establish a State department duly authorized to put in force everything that human ingenuity can devise in safeguarding human life, some good would certainly come of it, but with governments supported by pronounced partisans, the appointment



of special commissions usually amounts to the placing of high trusts in unworthy hands. Our hope is that associations of the kind that we have referred to may help to influence popular opinion, so that remedial measures will be brought into operation as the natural outgrowth of a broader and kindlier enlightenment. The American people do not desire to be forever at the tail end of the chase, as compared with other countries, but there is as yet too great a lack of concentrated effort in the one direction. Every movement which is intended as a healthy stimulus toward the formation of a rational public sentiment upon the simple matter of safety is a move in the right direction. The attainment of the object sought will not be the work of a few enthusiasts; to produce any lasting good the voice and will of the whole people must be heard and felt. It will not be accomplished by a babble of sound or the waving of many hands. It must be the forceful, determined grip on the life line and a united effort—a long pull, a strong pull, and a pull all together.

#### Limitations of Smoke Prevention.

When the steam boat was in its infancy and marine engines and boilers were so crude that it took about twelve pounds of coal to develop one horse power in the cylinders, speculations began to arise concerning the practicability of steamships crossing the Atlantic and making regular trips between New York and Liverpool. Dr. Dionysius Lardner, at that time regarded as one of the most accomplished scientific men of his day, ventured the opinion, based on knowledge of current marine practice, that a steam boat could not cross the Atlantic without the help of sails.

While Dr. Lardner was making predictions that have been used to make the scientist ridiculous, marine engineers were busy improving their engines and boilers, with the result that steamers began making regular trips across the ocean two years after Dr. Lardner's predictions were made.

The moral of that story is that engineering feats impracticable to-day may be made practicable to-morrow. The reverse of the case may also be true and things that are practicable, say, with small engines doing light work, may be impracticable with one hundred ton locomotives working up to their full power.

The writer had some experience as a locomotive fireman when the heaviest engine weighed about twenty tons. He took a great deal of interest in smoke prevention and succeeded in making the fire burn with scarcely any black smoke passing from the stack. In writing his book, "Locomotive Engine

Running and Management," he described the system of smokeless firing and found that it could be carried out on the light engines then in use in this country when the coal used was not particularly rich in smoke making gases.

In 1868 the writer was invited by the officials of the Burlington, Cedar Rapids and Northern Railway to attend and witness the smokeless firing practised with the locomotives of that system. He went upon the line and watched the working of the engines for several days, and they certainly did their work with very little smoke. When an article describing the system of smokeless firing was written the author added the following precaution:

"The system of firing described cannot be put into successful operation by merely issuing an order demanding its adoption. The enginemen are not alone able to commence the one or two shovelful system at once and make it work satisfactorily. The officials and enginemen require in the first place to co-operate together, the engineer helping the fireman in his manner of feeding the boiler and the fireman regulating his fire to meet the demands for steam. They must have the co-operation of several other officials. In the first place the coal purchased ought to be as nearly uniform in quality as possible, and it must be broken fine enough for firing without the fireman having to crack lumps to the burning size. Then the grates must be kept in good order. The defective plates and smoke box arrangement must be adjusted to suit the proper conditions of firing and the dampers must be kept in order, to act as dampers."

It became necessary in the interests of justice and fair play for the writer to look into the conditions of firing on other roads using a different quality of coal and having heavier engines worked a great part of the time at that maximum power. He found many locomotives where the one shovelful system of firing was followed because the fireman had no time to stop; but it was by no means a smokeless system, and no human being or mechanical stoker could feed the fire and prevent smoke. Coal that can be burned without causing smoke when burned in the fire box of an engine working lightly could not be prevented from causing smoke when the engine was working all the power it could develop.

During investigations in different parts of the country the writer found coal that would smoke no matter how it was fired or how the engine was worked. The preceding remarks have been brought out by the following letters which explain themselves:

The first was from Mr. A. J. Desoe, chairman of the Massachusetts Brotherhood of Locomotive Engineers Legislative Board. It was addressed to Mr. Angus Sinclair and was dated May 15, 1907, from South Framingham, Mass. Mr. Desoe wrote as follows:

"During a debate in the Massachusetts House of Representatives you were quoted by Representative Malcolm E. Nichols in support of his contention that 'dark or dense gray smoke' could be avoided. Now, the Brotherhood of Locomotive Engineers, as well as the railroad companies, have opposed his bill on the ground that it was a physical impossibility to live up to the provisions of the bill which says that 'such smoke shall not be allowed to escape from a locomotive engine for more than two consecutive minutes, or six minutes in any one hour of the day or night.' It also puts a penalty of 'one hundred dollars for each week during any part of which said section is violated, except that an engineer or fireman shall not be punished for the emission of such smoke if it is caused by reason of the material and appliances furnished by the employer.'

"Now, we were beaten out in the House, but we have great hopes of winning in the Senate. I write you asking if you would have any objection to sending me a communication that can be quoted from by our friends in the Senate, to offset what was said by Mr. Nichols. I believe that different States and municipalities have some very unjust and drastic laws for the purpose of regulating the 'Smoke Nuisance,' and we desire in Massachusetts to prevent any and all such laws appearing on our statutes. If you will kindly help us in this matter we will be very thankful. An early reply will be anxiously awaited."

The reply sent by Mr. Angus Sinclair, president and editor of RAILWAY AND LOCOMOTIVE ENGINEERING, was as follows, and was dated at New York May 16, 1907:

"Your letter relating to my writings on smoke prevention being quoted in the Massachusetts House of Representatives, is just received. This smoke prevention question is one where circumstances alter cases. The experience with smokeless firing described in my book on 'Firing Locomotives' was gone through on a railroad where the locomotives were comparatively small, were provided with brick arches and means of regulating the admission of air to the fire. The coal burned was not rich in volatile matter, that is smoke-making substances, and it was not difficult for the firemen to prevent smoke. The coal, though light, would produce very black smoke when care-

lessly fired. The fact that it was fired free from smoke illustrated a triumph of skilful firing, and my report of it was intended as a lesson of what could be done under careful and favorable circumstances.

"My teaching in this department of railroad industry has been greatly distorted by people with ends of their own to serve. While I held that smokeless firing could be practical under favorable conditions of fuel and work, people who used me as an authority implied that I taught that smokeless firing could be carried out in all cases and that there was no excuse for any locomotive creating smoke, which is not true.

"In a book which I have lately prepared called 'Railroad Men's Catechism,' being answers to the Traveling Engineers' Examination Questions, and on collections of questions used by nearly all railroad companies to test the knowledge of men seeking promotion, I have emphasized the fact that with some qualities of coal smokeless firing was impracticable. This is the teaching of a long experience, for I have watched very skilful firemen at work, and have myself fired locomotives equipped with the most approved appliances for preventing smoke, and yet a constant stream of black smoke would pour out of the smoke stack because the coal was of a character that could not have the gases necessary for perfect combustion mixed properly under the conditions that exist in a locomotive fire box. I have experimented with such coal in a laboratory furnace and found that conditions of high temperature and air admission could be found when the coal was burned without causing smoke, but the conditions could not be reproduced in a locomotive fire box. The conditions might be repeated in a furnace whose performance was uniform, but they could not be approached with a locomotive boiler with demands for steam changes every minute or every mile."

#### Apprentice Instructors.

In the vanished centuries when the apprentice was a part of the master's household, and not only wrought at the same bench, but sat at the same board as his master, the young lad's opportunities for learning his trade rose to the full measure of his capacity to absorb all there was to acquire in that particular establishment. With the improvement in mechanical appliances and the growth of large factories the relation of apprentice and master underwent a change. It is not worth while to argue whether the change was for the better or worse. It was inevitable and the question that naturally arises is whether the appren-

tice is being trained in his calling to the full measure of the opportunities that ought to be given him or not.

We do not think he is. We have been gratified to observe here and there a tendency to systematic instruction in the elementary scientific principles that underlie constructive work, but in the work itself, the methods of manipulation, the handicraft, as it is properly called, we have not seen anything at all approaching the old methods when the master and apprentice worked hand in hand together. In great, modern factories and workshops the master has other things to do. The same may be said of the heads of departments and foremen. Apprentices are largely left to their own resources. Instead of getting the best work to do under competent instructors they generally get the coarsest work, anything to keep them busy, and if they manage to pick up a smattering of their trade they will find that when they become journeymen they have much to learn yet. Some of these newly graduated mechanics are really pathetic objects, and are more to be pitied than despised. A few years of hard knocks may make fair hands of them, but at the start they did not get the instruction that they should have received.

It is easy to find fault. It is not so easy to provide a remedy. In the case of apprentices, as in all other educational processes, the instructed should have a special instructor. Foremen who have the faculty of getting good work out of other men are often below mediocrity as workmen themselves. In any event they rarely have time to give special lessons to apprentices. Their duty is to furnish work for others, to see that it is properly performed. They are responsible for the output.

A possible solution of the difficulty, it seems to us, would be the appointment of a suitably trained and equipped man for the post of mechanical instructor. Such a man might have charge of the entire class of apprentices all through their course, and be responsible to the company not only for the output of the young men, but for their training and instruction. Under such a system the apprentice class would undoubtedly give better value during their term and would be worth more to themselves and their employers in the end. This may look like a philanthropic scheme, but it has a very palpable dollar and cent side to it.

#### Present Status of the Compound.

The compound locomotive has been in use from about eighteen to twenty years in Great Britain and on the continent. Its introduction into this coun-

try was much later and was attended at the outset with much misgiving. There are several theoretical advantages which are claimed for the compound over the simple engine, and in some respects these advantages have been realized, but for ordinary everyday work the simple engine is thought by many to be a more satisfactory all round engine.

In England the Great Western Railway authorities, which have used the De Glehn compound extensively, are going back to the simple engine. In a series of tests recently made on that road the simple 4-4-2 and 4-6-0 types designed by Mr. G. J. Churchward, the chief locomotive superintendent of that line, have proved themselves to be more efficient than the compound engines of the Bosquet-DeGlehn type. This is one example, and though it indicates a tendency, does not necessarily mean that all compounds are to be summarily abandoned. On the Continent, however, the compound engine is still very popular, and may be for years to come.

In this country the tendency is toward the simple engine, and many roads have changed their compounds to simple engines when putting them through the shops for repairs. The new orders booked by the large locomotive building establishments may be fairly taken as an index of the present day tendency when it comes to a choice between simple and compound engines.

This is at a time of great prosperity, and the demand for steam locomotives is at present sufficient to keep the various locomotive building establishments in this country fully at work to the end of this year and beyond. But whatever the future may have in store for us, the demand for compounds has diminished. The older type of four cylinder compound is not called for, except for renewals; cross compounds are asked for to a certain extent and the balanced compounds appear to be the favorites when compounds are required.

The demand for compound locomotives of all classes is light. The number of compounds so far built this year at the Baldwin Locomotive Works amounts to six per cent of the whole output of the plant, and the American Locomotive Company, controlling ten separate locomotive building establishments, have built compounds in the proportion of between three and four per cent of their total output. It is probable that, striking a general average, it would be fair to say that the demand for compound engines by the railways of the United States, Canada and Mexico would now be in the neighborhood of five per cent of the whole number built.

### New Northwest Passage.

Senator Ferguson recently submitted a scheme before the Canadian Parliament that opens up a new pathway between the Dominion and the mother country that is not only feasible but is likely soon to blossom into accomplishment. Railways are to be constructed leading from the great wheat fields of Manitoba and Saskatchewan to ports on Hudson Bay. From these ports a line of steamers will traverse the waterway to Liverpool. Navigation is open for four months in the year, and the distance from the Canadian wheat fields to the British and European markets will be lessened perhaps a thousand miles. There are no icebergs in the great inland sea and the few that may be encountered in Hudson Strait are carried in by an ocean current and are invariably carried out by another current. The navigation season is almost confined to the period of long summer days when the daylight scarcely disappears. In every way it would be a much safer route than the present route along the St. Lawrence, and would not only effect a saving in freight rates but would relieve the congestion on the present Canadian grain route.

In this proposition as in others affecting the development of vast areas of agricultural lands the locomotive is the great pioneer in the work of bringing the ends of the earth together. The traversing of the rich western fields and the drawing of full trains to the shores of Hudson Bay is the work that the steam engine makes possible. What are the dreams of to-day, in a few years become accomplished facts, and soon the untrodden wilds of the north land will hear the hum of commerce and the locomotive will wake the echoes on the now silent shores of that great northern inland sea.

### Inland Traffic by Water and Rail.

There is no doubt that river and canal transportation have very seriously declined. In 1860 the Erie canal is said to have carried 65 per cent. of the total traffic upon New York railroads and canals. In 1903 it did 4 per cent. of the business. A New Orleans paper has recently been pointing out that the Mississippi river has been well-nigh abandoned.

In an address to the International Railway Congress of 1905 Mr. Stuyvesant Fish said: "Twenty years ago 100,000 bales of cotton—as a single item—were carried by steamboats from Memphis to New Orleans, but in no year since the railways along the river-side passed into single ownership has so much as 500 bales been thus carried, for the reason that rates by rail are lower, if the necessary marine and fire insurance by steamboat route be included in the charges. Between 1890

and 1900 the river traffic has declined 1,855,792 tons, and the railway traffic has increased 3,294,322 tons."

It has been pointed out that it was these early cheap water rates which forced the railroads to lower rates so as to meet the competition and we are told by statisticians that the products which are carried on railroads have doubled in the last ten years, while the facilities for handling this growing business have increased only one-eighth.

### Book Notices.

Random Rhymes and Rhapsodies of the Rail, by Shandy Maguire, 16mo, 412 pages, ornamental cloth, with portrait of the author. Price \$1.50. Copies may be obtained from the author, Shandy Maguire, Oswego, N. Y.

A volume of verses from a railroad man is a unique production, and when the verses reflect the experiences of actual life on an American railway with all its light and shadows, its perils and pathos, its trials and triumphs, it is certainly worthy of more than a mere passing notice. Shandy Maguire is no stranger to the readers of RAILWAY AND LOCOMOTIVE ENGINEERING. His letters and character sketches in prose have appeared at intervals in our pages and have been warmly appreciated by tens of thousands of railway men all over the world. His poetical productions now appearing in the first complete collected form deserve and will certainly receive an equally warm and enthusiastic reception. The same characteristic qualities that distinguished the prose writings of the rugged railroad man mark the productions in verse before us. It is a collection of human experiences told in melodious numbers. It is a reflex of the hopes and fears and loves and joys of the railroad man set to music. The music may not be as high sounding as that of some of the mighty masters of song, but this poet of the rail comes as near to the heart of those whose life work he sings as any twentieth century bard does in his chosen sphere.

Through the entire book we find the pride and joy of the man that loves his calling, that finds his occupation suited to his mental and physical equipment and is supremely satisfied with its royal rewards. We catch a glimpse of this in "An Engineman's Joy":

"I love a flight, on a summer's night,  
O'er the prairie's wide domain,  
On my noble steed, in her matchless speed,  
As she wheels the flying train.  
How her sharp exhaust keeps the cinders tossed  
Up high in the balmy air,  
And the track ahead, on its rocky bed,  
Is swept by the headlight's glare.

When my trip is o'er, through my cottage door  
Bound my boys and girls in glee,  
With their joyous cries, full of glad surprise,  
And their kisses sweet for me.

Oh! I gain new life as my bonnie wife  
With her cheerful smiles I greet,  
And I thank the Lord for the blessings stored  
In the cot full of joy so sweet.

Of the unsung heroes of the rail he is the most eloquent and most poetic living exponent. His home-keeping muse never wanders into foreign fields. She wings her flight with him on the mighty engines through the green fields and by the crystal waters and past the sleepy hamlets and clothed in thunder comes into the appointed place at the appointed hour. Sometimes sad and sobered she sits by the bedside of "Billy Kane" and Shandy chants a song of deliverance from death when the bruised and broken man comes back to his place on the foot-plates again.

Official orders come in for a proper share of poetical notice. Sometimes they touch a chord that calls for a protest as in "Flirting Officially Prohibited":

"If she were standing near the track,  
And did a signal to me make,  
Though I ne'er fetched your engine back,  
I'd flirt until my arm would ache;  
I would, if both injectors 'broke,'  
Or pumps gave out, or crown-sheet bare,  
I'd also let the crank-pins smoke,  
Till I'd salute this lady fair!

Indeed the gentler sex come in for considerable attention from the gifted Shandy and there is an unmistakable echo of Moore's melodies in his graceful tributes to woman. In the higher realm of invention there is no striving after dramatic effect, but in "Jack Reagan's Ghost" and "A Midnight Visitor" we have glimpses of the unseen world that would make a strong man sit nearer the fire on a winter night.

Random quotations, however, are but broken splinters that should not be taken in any sense as samples of finished work. Railroad men should buy the book and read it, and they will find vocal musical utterance given to the common thoughts that make up the inner life of the men that live and move and have their strenuous being on railways.

Locomotive Breakdown Questions answered and illustrated by W. G. Wallace. Published by F. J. Drake & Co., Chicago. 285 pages, with numerous illustrations, flexible leather binding, 1907. Price, \$2.00.

Mr. Wallace has produced an excellent book in the work before us, and places in convenient form the product of many years experience on railways. The questions and answers composing the bulk of the volume have already appeared in some of the technical journals and have been collected and carefully revised by the author. They cover a wide range of subjects. Considerable care has been taken in the indexing of the book, which renders information on any subject ready of

access. The book has the double merit of being finely printed and substantially bound.

**Locomotive Compounding and Superheating**, by J. F. Gairns. Published by J. B. Lippincott Co., Philadelphia. 180 pages, with 150 illustrations, 1907. Cloth, price \$3.00.

The subject of compounding and superheating is of such recent and growing importance that the collection of matter relating to the various apparatus in use has not been particularly placed in a comprehensive form before the engineering world. The work will therefore be welcomed by all who are in any way responsible for the design and efficiency of locomotives doing varied work. To provide a complete and systematic work on the subject has been the object of the writer, and it is evident that he has had excellent opportunities for obtaining information from locomotive engineers and locomotive building firms. The work is divided into fifteen chapters, the early portion of the work being devoted to a glossary of terms and an analysis of the special conditions governing the application of compounding and superheating. The bulk of the book is devoted to special divisions of the subject dealing with past and present practice. In brief, the work may be said to be an able presentation and a general review of some important branches of locomotive engineering.

**Design of a Railway Bridge Pier**, by Charles Derleth, Jr., C.E. Published by the Engineering News Company, New York. 24 pages, with 7 full-page illustrations. Price, 50 cents.

On the subject of "Railway Bridge Piers" Professor Derleth, of the University of California, prepared a special study at the request of the editors of the California Journal of Technology. The able document attracted wide attention and it is generally believed that the subject has been treated by him in a more complete and efficient manner than any text-book now extant. Its appearance in the form before us can not fail to be of special value to students and constructing engineers, and among these especially the pamphlet will have a wide circulation. The large page of the pamphlet gives full opportunity for illustration of drawings which are of real value, and will commend the work to the attention of constructing engineers.

**Practical Mechanics for Shop Apprentices and Others**. By James Powell. Published by the Witness Press, Montreal. 54 pages. With 20 illustrations.

Mr. Powell, Chief Draughtsman, Grand Trunk Railway System of Canada, has

published an excellent little book especially for the use of railroad shop apprentices, but which will be found to be useful for many whose apprentice period is ancient history. The author has had exceptional opportunities, having been for some years in charge of evening classes, teaching geometrical and mechanical drawing, and his services have been highly appreciated by those who have had the good fortune to come under his intelligent tutorship. In the work before us he should immediately command a wider field of influence. It possesses in a condensed and attractive form all that is essential as a preparation for higher education. It is utterly free from superfluities and presents what is actually needed by every mechanic who aims at equipping himself for the constantly expanding requirements of his calling. The book is finely printed and neatly bound.

#### Grease Moulder.

There is a very interesting machine to be seen in the Susquehanna, Pa., shops of the Erie, of which Mr. H. H. Harrington is the master mechanic. It is nothing less than a machine for moulding compression pin grease. That is the official way it is described, but the main object of the machine is to turn out grease cakes and the way it does it is a sight to see. The grease cakes are made in batches, just as cakes should be made, and they look something like pats of butter, but you had better not

grease cylinder, like unto a steam port, 2x5½ ins., only it is used by the diligent operator to introduce grease into the grease cylinder when the piston is drawn back.

The grease cylinder terminates in a cone-shaped casting about 7¼ ins. long. The stroke of the air and grease cylinders is 7 ins. and as the grease cylinder is 10 ins. long the movement of the grease compressing piston is such that although the grease is forced into the taper casting and out of the small end, it is not squashed into nothing. It remains good grease to the very last.

At the end of the taper casting is a cylinder of brass 2¾ ins. inside diameter, and into this the smooth solid cylinder of grease is forced. This brass casting has, however, been sawed almost through, in 8 or 9 places, and a handle with a hinged lever is attached to the table at this point. The lever is really a frame with blades of Russia iron set exactly opposite the saw cuts in the brass cylinder.

Now, when a solid cylinder of most excellent grease has been forced into the brass cylinder, the operator brings the Russia iron blades down, they enter the saw slits and cut the grease into neat little cakes. As the cakes are exactly the diameter of the engine oil cups you have a lot of grease cakes, each one of which fits a cup to a nicety and two or more will fill a cup neatly.

The company provides tin boxes which just hold the grease cakes and in that

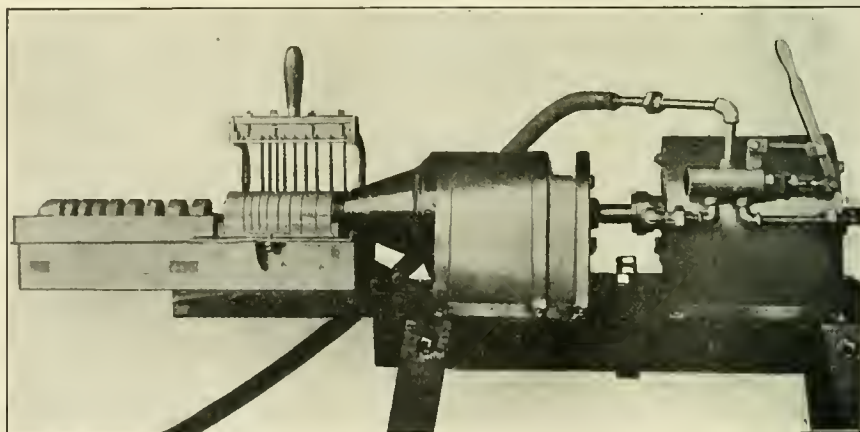

GREASE MOULDING MACHINE.

make any mistake with them as a substitute for butter at lunch time.

The machine stands on a trestle and at one end of it there is an old air cylinder with piston, piston-rod, a three-way valve and all the regulating appurtenances thereof. The valve is operated by a small hand lever and when air enters one end of the cylinder the piston proceeds to the other end. There is another similar cylinder in line with the first, which we may call the grease or low pressure cylinder of this tandem engine. There is an opening in the wall of this

form they are issued. Take off the cover of the tin box and you can shake out a cake of grease perhaps 1 or 1½ ins. deep and of the diameter of the cup, and there you are, or rather, there is the grease cake. This is how they do it on the Erie at Susquehanna, Pa., and the grease moulder is a "slick" machine.

"You musn't mind what other people do. If their souls were your soul it would be different. You stand or fall by your own work."—*Rudyard Kipling*.

# Correspondence School

## Fourth Series—Questions and Answers.

21—If blower is put on too strong when cleaning the fire, what is liable to happen?

A.—Too much cold air is liable to be drawn into the firebox and this would very probably cause the flues to leak.

22—How much coal does your engine burn each trip?

A.—This answer must be made in accordance with your own experience.

23—How does this compare with the other engines of the same class in the same kind of service?

A.—This answer must be made in accordance with your own experience and observation.

24—Do you consider it wasteful to have an engine blow off steam frequently?

A.—Yes, very wasteful.

25—What are your first duties when going out of the house with the engine?

A.—Be on duty the full time prescribed by the company before train leaving time, ascertain that the fire is in good condition, steam up on the engine, the necessary tools, signals, lamps, etc., in place, and the engine supplied with coal and water and ready in every way for the trip.

26—What tools do you consider necessary?

A.—Answer according to the practice of your own railway.

27—What supplies?

A.—Answer according to the practice of your own railway.

28—How do you locate a pound in an engine?

A.—When engine is running if a pound of any kind develops the first thing to do is by careful observation to ascertain which side of the engine it is on.

29—If pound is in the rods can you always locate it? How?

A.—A pound in the rods is most easily recognized when the direction of motion changes, that is, at the beginning and end of the stroke.

30—How should you commence to key up Mogul or ten-wheel engine?

A.—The object in keying up the rods of a Mogul or ten-wheel engine is to secure a good accurate fit to the rod brasses without causing them to grasp the pins too tightly. The engine should be in steam and should be placed on straight level track. The wedges should be adjusted, all the keys should be slackened and the butt end of the main rod should be keyed first. The main crank pin should be upon the forward or back centre when this operation is performed. The other bearings should be keyed up on each

side of the main pin. The engine should then be moved to the quarters and the other centre. It may be that the rods, while working freely at the dead centres, may tighten a little as they approach the upper or lower quarters. This is caused by the fact that the wheels are resisting the pulling force of the rods and it should be distinguished from tightening of the bearing at these points. If the connecting rods move freely on the bearings at both dead centres it is safe to assume that the bearings will run easily at all points, the only exception being in the case of crank pins that are worn out of all semblance to roundness.

31—If pound is in wedges, can you set them up and get them right the first trial?

A.—It is not likely that one can do

broken, it is possible to unite the broken ends by entering them and screwing them a few times into a nut. If this cannot be done, the wedge may be kept up by placing a nut or other piece of solid matter below the wedge and on the pedestal binder, and wiring it in place.

35—If follower bolts are loose will it make a pound?

A.—Yes, and the pound is likely to cause a broken front cylinder cover.

36—How do you detect this trouble?

A.—A pound due to loose follower bolts occurs at the forward end of the stroke only.

37—How do you remedy it?

A.—Stop at once. Take off front cylinder cover, and tighten up the loose bolts or remove them altogether.

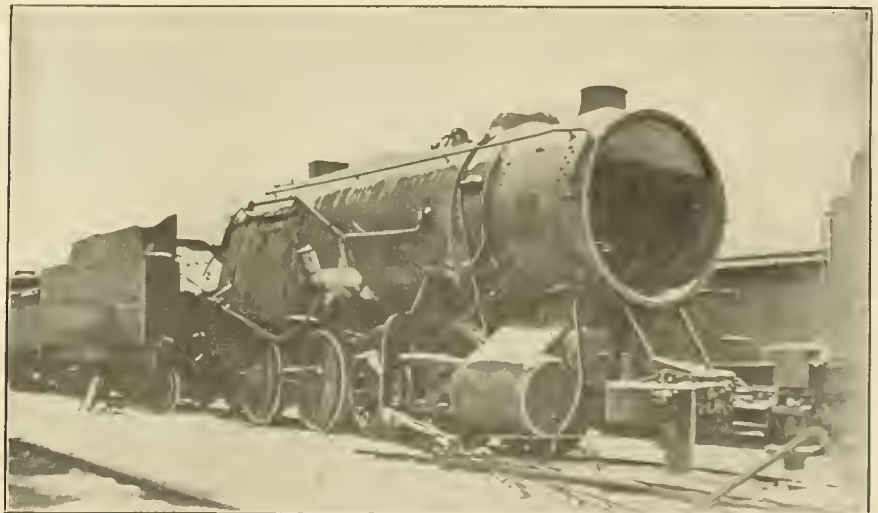

RESULT OF BOILER EXPLOSION.

this on the first trial, but there is no impossibility in it.

32—How do you do this?

A.—The setting up of the wedges is done by first drawing the boxes against the front shoes. This may be done by pinching the engine ahead or by using steam with main crank pins above the centre line of the wheels. Then the live wedges should be run up tight or snug, marked and drawn down about  $\frac{1}{8}$  of an inch in order secure the requisite amount of play between box and shoes.

33—Will an engine pound if pedestal bolts are loose? Why?

A.—Yes, because the wedge is not held securely in its proper place and the wedge can slip down.

34—When wedge bolts are broken, how do you keep the wedge in position?

A.—Sometimes if the wedge bolt is

38—If cylinder packing is blowing through, how do you tell which side it is on?

A.—If cylinder packing is blowing, put the engine say with left side so that the ports are blocked, open cylinder cocks and give a little steam. You then have steam on one side of the right piston. If the piston packing is blowing steam will pass to the other side of the piston and blow up the stack. Try the same thing on the other side of the engine, and if only one side shows a blow of steam up the stack, that is the side with the defective packing. A defective piston valve will give the same blow.

39—Will steam come out of both cylinder cocks at the same time on the same side?

A.—Yes. Steam will come out of both cylinder cocks.

## Elements of Physical Science.

## II.—MOTION.

Motion is either absolute or relative. The former is a change of place with reference to a fixed point; the latter motion has reference to a point that is itself moving. The motion of two balls rolled on the floor is absolute; their motion with reference to each other is relative.

Rest is the opposite of motion, and has also the two primal qualities of motion. A body resting upon the earth may be said to be absolutely at rest. A body resting upon a moving body is at rest relatively to the other objects similarly situated. It may be added that although the earth is passing through space at the rate of over 18 miles per second, all bodies having no other motion than that of the earth are regarded as being absolutely at rest.

Velocity is the rate at which a body moves, and the velocity of a body is found by dividing the space passed over by the time occupied in passing. It is interesting to note the varying velocities of a few common objects: A man travels 4 miles an hour, an express train runs 50 miles an hour, sound travels 764 miles an hour, while electricity conducted in a copper wire will flow 288,000 miles per second, or nearly twelve times around the earth in one second.

There are three kinds of motion—uniform, accelerated and retarded. Uniform motion is that of a body moving over equal spaces in equal times. Accelerated motion is that of a body whose velocity increases as it moves, as in the case of a ball dropped from a height. Retarded motion is that of a body whose velocity diminishes as it moves, as in the case of a ball rolled over the ground.

## MOMENTUM.

Momentum is the quantity of motion in a body, and is found by multiplying the velocity of a body by its weight. Thus if a ball weighs 12 lbs. and travels at the rate of 500 feet per second, the ball has a momentum of 6,000. It will thus be seen that momentum depends on both velocity and weight, and so by increasing the velocity to a sufficient degree a small and light body may be made to have a greater momentum than a large one. This is readily understood by comparing the force of a small bullet of lead fired at a high velocity from a gun and the force of a large iron ball thrown from the hand. On the other hand a large body possessing weight, though the motion be hardly perceptible, may also have enormous momentum, as in the case of an iceberg which will crush a ship to pieces. It may be remarked that two bodies moving

with the same velocity have momenta proportioned to their weight, and two bodies of the same weight have momenta proportioned to their velocities.

In comparing the momenta of different objects their weight and velocity must be expressed in units of the same denomination. If the weight of one is given in pounds, that of the other must be in pounds also. If the velocity of one is so many feet per second, that of the other must be expressed in feet per second. When different denominations are given, they should be reduced to the same denomination.

## STRIKING FORCE.

The striking force of a moving body is the force with which it strikes a resisting substance. It is apt to be confounded with momentum, but two moving bodies may have the same momentum, but differ greatly in their striking force. The momentum, as already stated, is ascertained by multiplying the weight of the moving body by its velocity. The striking force, on the other hand, is ascertained by multiplying the weight of the moving body by the square of its velocity.

As an illustration, if we suppose a train of cars moving at a velocity of 50 miles an hour, and another train of the same weight moving at the rate of 10 miles an hour, the striking force of the former will not be, as may be at first supposed, only five times that of the latter, but it will be twenty-five times greater, as the square of 50 is 2,500, and the square of 10 is 100, therefore the ratio is 25 to 1. This fact has been repeatedly demonstrated by actual experience.

In the case of bodies having the same momentum, but varying in striking force, let us suppose a train of cars, the total weight including locomotive and tender being 500 tons, moving at 20 miles an hour, and another train weighing 250 tons moving at a velocity of 40 miles an hour. Both trains would have a momentum of 10,000. By squaring their varying velocities we will find that the proportion would be as 400 to 1,600. That is, the train moving at 40 miles an hour would strike a blow four times heavier than the train traveling at 20 miles an hour, even while it is only half as heavy as the slow moving train.

In all calculations of this kind it is necessary, when different objects are to be compared, their weight and velocity must be expressed in the same denomination. If the weight of one is given in tons, that of the other must be in tons; if the velocity of one is so many miles per hour or feet per second, that of the other must be expressed in the same manner. If different denominations are given, reduce them to the same denomination.

## Questions Answered

## CAUSE OF TANK JUMPING.

(50) L. C. B., Covington, Ky., writes: Why is it that an engine tank will begin jumping at high speed when the coaches and the engine run perfectly smooth? Is it the water which causes this? A.—The tender is lighter than either engine or coach, and the weight of water and coal on the tender varies from time to time. It may be that when the tender becomes comparatively light the springs are not heavily compressed and have a tendency to dance. We remember some engines which had coil springs in the tender trucks, and at times the tender bounced so much that the fireman could hardly stand on it. You may sometimes see the same action on a light box car. A familiar example of somewhat similar action may be seen in a modern baby's carriage where the springs are purposely designed to act readily with slight shocks. The carriage bounces more or less, but as the vibrations are slow and as the springs give a good deal, the motion is not excessive.

## RUNNING GEAR.

(51) L. C. B., Covington, Ky., asks: What would you consider to be the running gear of a locomotive? A.—The running gear of a locomotive is generally considered to be those parts which carry the moving machine, such as wheels, tires, axles, trucks, frames, boxes, springs, equalizers and connected parts.

## VALVE SETTING.

(52) L. C. B., Covington, Ky., writes: We are setting the valves on the Atlantic type, piston valve engines, with 1-16 in. lead going ahead in full gear, and blinding the backing up motion enough to give 7-32 in. lead at 5 or 6 ins. cut-off. These valves have one inch lap, and are line and line on the inside or exhaust side. Would you recommend giving engine ¼-in. clearance on a side, which would make quite a difference in steam release? A.—Inside clearance is often beneficial for engines which run at high speed, as it causes the release of steam in the cylinder to occur earlier and compression later in the stroke. For high speed it is the getting of the steam out of the cylinder which is the important thing. If your engine is for service where long, fast runs are the rule, inside clearance will probably help, but it depends entirely on the service for which the engine is intended, and ¼-in. inside clearance is too much for ordinary conditions. On general principle we may say that it is always safe to presume that the calculations regarding the original con-

struction of the valve gear were correct. Errors are generally in the adjustment, and the tendency to increase the error by the accumulation of lost motion is inevitable. The position of the valves should be occasionally examined by an expert machinist, and the readjustments carefully made and the action of the valve should be particularly noted with the reverse lever set in the same notch as is used in general service.

#### MAIN AXLE CHANGED.

(53) J. H. J., Bluefield, W. Va., writes: If you take the main axle from under a locomotive and turn it end for end, that is, put the right driver and eccentrics on the left side and connect up everything as before, what will be the effect? Will the engine go ahead with reverse lever in forward position? A.—The effect would be that the eccentrics and eccentric rods would require some slight alterations in order that the valve openings would occur correctly. Organic changes take place on the most accurately constructed engines on account of the wearing of rocker boxes and lifting shaft blocks and consequent alterations in the length of valve rods, all of which affect the interchangeability of parts. If every part was mathematically perfect, the turning of the main axle end for end would cause no difference of any kind other than the fact that the left crank would become the leading one instead of the right. The engine would run ahead with the reverse lever in the forward position as before.

#### MOVABLE DIAPHRAGM.

(54) J. P. G., Meadville, Pa., writes: I cannot see any sense in having diaphragm sheets in the smoke box made so that they can be raised or lowered. We never touch them except when repairing the engine. What effect would the moving of the diaphragm have on the steaming qualities of an engine? A.—The raising or lowering of the diaphragm has the effect of varying the amount and also the central location of the draft of air through the fire. Lowering the diaphragm moves the centre or stronger part of the current of air to the front of the fire box, with the result that the greatest degree of heat passes through the lower flues. On the other hand the raising of the diaphragm causes an increase of draft in the back of the fire box and a consequent stronger rush of heated air through the upper flues. It is usual when an engine is being newly tried or after repairs have been made to observe the action of the draft on the fire and regulate the diaphragm accordingly. With the diaphragm once set in the best position it is not advisable to change it unless a change is seen to be really necessary. It may be added that the diaphragm is better to be set low than too

high as the greatest degree of heat passing through the lower flues has a better opportunity to become absorbed in the upward boiling of the water.

#### WIPED JOINT ON LEAD PIPE.

(55) R. N. G., Braddock, Pa., writes: What are the solutions necessary in making a wiped joint on a lead pipe?—A. There are no particular solutions necessary. Melt the solder in a ladle and pour it on the joint. When the pipe becomes heated by the molten solder, the solder will begin to adhere, and as it accumulates on the joint it should be wiped into shape with a piece of strong cloth greased with tallow.

#### SLIP OF DRIVERS.

(56) E. M. P., Carnarvon, Ia., writes: I had an argument with a fireman friend of mine regarding a locomotive passing around a curve. I claim that the drivers, on a certain side must slip on the rail a small amount, for if the two rails were laid out straight, the outside one would



TAY BRIDGE AT DUNDEE, SCOTLAND.

be the longer and so the wheels on one side would slip slower than the speed of the engine would be on the straight track, or the wheels on the other side would slip on the rail faster than the speed of the engine, assuming that the drivers on the opposite side of the slipping ones grasped the rail firmly. Kindly give me your opinion. A.—You are right enough about the slip of the drivers. As the wheels on both sides of the engine are the same size and are rigidly secured to the axle, both pass over the same distance each revolution on straight track. On a curve the length of the inner rail is necessarily shorter than that of the outer rail. If the rails of a curve were straightened out and it was found, say for example, that the outer one was 20 ft. longer than the inner one, the slip of the drivers would be just that amount. If the wheel on the longer rail did not slip, the wheel on the shorter rail length would slip, and vice versa. As to which actually does the slipping no very accurate data exist. It is probable that they both do some slipping, and in this case the total slipping done by either or both wheels would be equal to 20 ft. slip for one wheel. The difference in the length of rails on curves is what makes a stalled train start harder on a curve than it would on straight track.

#### TRUBLE WITH SAFETY VALVES.

(57) C. C. C., Chino, Cal., writes: We have an engine here where the dome is in the cab, and the pop valve is connected to a 1½ in. by 12 ins. long pipe. The old pop became worn so it became necessary to replace it with a new valve. The first time the pop raised at 140 lbs. and continued to blow until all the steam was out of the boiler. The valve was repaired, as it had a broken stem, and again it broke the stem and steam was blown out of boiler. The manufacturers claim it was the 12-in. long piece of pipe that caused the stem to break. Another engine here has two pops on one pipe from dome, with a tee 20 ins. from dome, with a nipple and L each side of tee where the pops are attached. The first pop valve that was removed had seen 10 years' service without a broken stem, and attached to pipe the same as new valve. Would be pleased to hear from you as to cause of this valve breaking, also the proper manner to place pop on boiler. A.—Good practice is to set all pop valves right down on the boiler or dome without using any intervening pieces of pipe. If it is necessary to connect them by means of pipe, the fewer the tees and elbows or turns you have the better. Where pipe has to be used it should be as short as possible, and of the same size or even slightly larger than the valve. With the small pipe of which you speak in the first case, and possibly a sensitive spring, the valve probably opened and shut rapidly many times while blowing off, or, in other words, pounded itself somewhat out of shape, and so broke the stem. This action, when it takes place, is thought to be due to the partial momentary reduction of pressure in the small pipe, followed by the valve seating and being at once opened again by the pressure again rising in the pipe. In the second case where you say the valve worked all right you do not give the size of the pipe. A valve where the spring is not sensitive and the pop not very accurately adjusted, or slower in its action, might under these circumstances not give the same trouble as the more sensitive one. The best kind of pop valve, set in the most approved style, is none too good for a locomotive. Do away with the pipes if you can, or make them short and plenty large.

#### G. W. R. Taper Boilers.

A form of taper boiler is being fitted to all Great Western Railway engines as new engines are required. This form of boiler has been in use on the Taff Railway for nearly thirty years for engines employed on steep gradients.

### T., H. & B. Ten-Wheeler.

A good example of the work done at the works of the Locomotive & Machine Co. of Montreal, Limited, may be seen in our illustration, which is of Engine No. 10 for the Toronto, Hamilton & Buffalo Railway. The engine is of the ten-wheel type, and is intended for passenger service.

The cylinders are simple 20 x 26 ins. The driving wheels are 73 ins. in diameter, and with a boiler pressure of 200 lbs. the calculated tractive effort of this machine is about 24,200 lbs. The main valves are of the Richardson balanced type, actuated by Walschaerts gear. The weight of this engine in working order is 182,000 lbs., of which about 137,000 lbs. is on the drivers. This gives a ratio of tractive effort to adhesive weight of about 5.

The boiler is of the extended wagon top type, 66½ ins. in diameter at the smoke box end. The firebox is 102 ins.

### Expeditious Ore Handling.

With the opening of navigation this year the Erie Railroad's new ore yards at Cleveland, Ohio, will be placed in operation. Several hundred thousands of dollars have been expended in modernizing the ore unloading plant, and the capacity has been doubled. The 15 old-fashioned Brown rigs for unloading ore have been torn down and sent to the scrap heap. This plant, when erected many years ago, was considered at the time the finest on the lake front. In its place has been erected a new Brown Fast Plant, consisting of 4 machines, with a capacity for unloading a 10,000-ton boat in 4 hours and loading 600 cars in 12 hours from its five-ton buckets. It is also provided with 4 automatic suspended weighing buckets of 200 tons capacity each. These add to the rapidity of work by automatically weighing and dumping the ore into each car as it runs under

midway between the two plants and on tracks leading directly to the yards. This yard, which covers an area of nearly 10 acres, has been completely remodeled during the winter, levelled by an average fill of 4 ft., with new 80-lb. rail substituted on all the switch tracks. Power for the operation of the plant is furnished from a new power house at the lower end of the yard. The acme of economic handling has been achieved in these yards. Cars from the coal regions are drawn into the yards loaded, carried down the river to be unloaded, where they are automatically tipped over into chutes feeding directly into the boats, then they are switched and run back to be reloaded.

### Worth of the Hand.

A rather thoughtful young man was once upon a time asked to give some characteristic of the man-like apes. He



TEN-WHEEL PASSENGER ENGINE FOR THE T., H. & B.

J. Christopher, Master Mechanic.

Montreal Loco. & Machine Co., Ltd., Builders.

long, by 65¼ ins. wide, which gives a grate area of 46 sq. ft. There are 336 tubes 15 ft. ½ in. long, and these give a heating surface of 2,632 sq. ft. The fire box gives 160 sq. ft., making a total of 2,792 sq. ft. This gives a ratio of grate surface to heating surface of about 60.

The tender has the ordinary steel frame, with U-shaped tank containing 5,500 Imperial gallons, and carries 9 tons of coal. The fuel space has sloping sides. Some of the equipment is Tower couplers, Westinghouse brakes, Nathan lubricators, blow-off valves of the American Loco. Co., the Hancock and Monitor injectors, Monarch brake beams, Hayden safety valves, Leach sanders and Higginbotham bell ringers. The builders are the Canadian branch of the American Locomotive Company. The engine presents a neat and trim appearance. We are indebted to Mr. E. Fisher, the general superintendent of the road, for the photograph from which our illustration is made and for the other data.

the feeder. Gondolas of 50 tons capacity each are ordinarily used in hauling ore, though the Erie has provided a number of 75-ton cars for use in hauling to the Randall yards for storage.

This new plant, supplementing the one installed two years ago, gives to the Erie on the Old River dock the fastest and finest plant anywhere on the Great Lakes. The new plant has been erected alongside the recently straightened docks. The machines are operated over tracks of 100-pound rails laid on groups of 50-foot piles, driven as closely together as it was possible to put them and topped with heavy oak stringers. This runway is 500 ft. long, and so can operate on a 600-ft. boat, unloading from all the hatches at once. Power to operate the plant is conveyed by a third rail laid alongside the runway tracks. To facilitate rapid weighing of cars loaded at the Fast Plant erected two years ago, two new 150-ton scales, each 42 ft. long and equipped with the Streeter-Ames recording device, have been installed

replied promptly enough: "The upright position of the body and the opposable thumb." This description of the thumb means that it can be opposed or placed against any of the fingers of the hand, hence the ability of a hand with an opposable thumb to grasp things. A hand without this characteristic is practically a claw, and though it can move things about it cannot hold them. It is the ability to hold things in the hand and so subject them to examination which has been thought by some evolutionists to be the reason for the beginning of thought and the birth of reason. Any workman knows the value of the thumb. Taking the value of the whole hand as equal to 100, in France the court allows in damages 15 to 35 per cent. value for the right and 10 to 15 per cent. for the left thumb. The rating in an Austrian court gives from 15 per cent. for the left to 35 per cent. for the right. In Germany 20 to 28 per cent., and even as high as 33.3 per cent. has been awarded. It is a case of "thumbs up" in any country.



# Air Brake Department

## Fourteenth Annual Convention.

Promptly at 9 the members of the Air Brake Association met in convention at Columbus, Ohio, in the convention hall of the Great Southern Hotel on the morning of May 14th, with President W. P. Garrabrant in the chair.

The members were welcomed to the State and the city by Governor Harris, Mayor Badger and Sheriff Karb, who in their addresses to the members paid a very high tribute to the Air Brake Association for the good it had accomplished in its chosen field of endeavor

of brakes was the most important thing now confronting the association, while a careful mastery of the improved brakes now coming into general use should also receive attention.

After the usual intermission to give the ladies an opportunity to retire, the members came to order again, and then listened to the reading of the reports of the secretary and the treasurer.

These reports show that the association is in a very healthy and flourishing condition with respect both to membership and finances.

The reading of the reports was begun by Mr. T. L. Burton, the subject being "Air Brake Control on Heavy Grades of Trains Composed Exclusively of Fully Loaded 100,000 Pound Capacity Cars." This paper reported the methods employed on one of the leading roads in the country in dropping their trains down grades of approximately three and one-half per cent, and it illustrated very clearly the advantages which the K triple valves have in grade work over the ordinary triple valve as regards both the increased tonnage that can be handled



RAILROAD CURVE AROUND MOOSEHEAD LAKE, GREENVILLE, ME.

during the fourteen years of its active life, each concluding by wishing the association a profitable meeting and pleasant time while visiting in the city. Sheriff Karb referred in his remarks to the fact that he had the honor of being the first official to address the association when it first convened in Columbus fourteen years ago.

Following the remarks of Sheriff Karb came the address of President Garrabrant. In this address attention was directed to the changed conditions in the air brake field at present from what they were a number of years ago, and to the fact that good maintenance

The secretary in his remarks referred to the pass restrictions now in operation, and stated that these restrictions had the effect of preventing many members from attending the convention. This handicap was in a large measure detrimental not only to the interests of the association, but also to the railroads, who have always reaped the benefits of its work.

It is hoped and expected that before the next convention is called the pass situation will be settled in some reasonable form, so that members will not be hampered in the matter of transportation.

down heavy grades and the greater factor of safety with which this may be done.

Following Mr. Burton, a report of a test made with K triples on the heavy grades of the Central R. R. of New Jersey was read by Mr. P. J. Langan.

The discussion which followed the reading of these reports was animated, and it occupied all the remaining time of the first day's session, as it was quite generally participated in by the members present.

The danger of occasional failure of the air brake and the unreliability of the hand brakes, when they are re-

sorted to at a call from the engineer, was referred to by Mr. Alexander of the P. R. R. in his remarks, and they were urged as reasons for exercising care and vigilance on heavy grades. He also thought that "man failure" in grade work should be carefully guarded against.

The importance of the time element in grade work was touched upon by Mr. Langan, of the D. L. & W. R. R., while Mr. Otto Best, of the N. C. & T. R. R., laid considerable stress on the importance of good maintenance, and mentioned the danger to be apprehended in grade work from leaky packing leathers and brake cylinder gaskets.

Mr. Parker, of the Great Northern, touched on the subject of overheated and cracked wheels from the use of hand and air brakes combined on the same cars, and stated as his experience that these defects were not produced when the air brake alone was used for controlling trains. His grades averaged 110 ft. to the mile, and they were from ten to fifteen miles long.

As the operation of the K triple in heavy grade service received considerable attention, both in the reports and in the discussion, Mr. W. V. Turner, mechanical engineer of the Westinghouse Air Brake Co., explained very clearly the points of quickness of operation and economy in air consumption, two vital points in successful train handling on grades where cars have this type of triple.

Mr. Borland and Mr. Gibbs, the Interstate Commerce inspectors, inquired for the names of roads on which trains were handled successfully in heavy grade work, and they learned of several roads where trains were handled successfully exclusively by air, that is, without assistance from hand brakes, down long grades.

Mr. F. B. Farmer, of the Westinghouse Air Brake Co., stated, in answer to an inquiry regarding average grade of the country, that it was about 2.2 per cent, and added that heavier grades were not very numerous.

The discussion as a whole indicated that the K triple possessed important advantages in grade work over the ordinary standard, but nevertheless to operate safely, speed while descending grades must be maintained within safe limits.

Before adjournment the genial "Judge" Hutchins announced the program of entertainment. This program included a visit for the ladies to the Carnegie Library, a visit for the members and ladies to the Blind Asylum and Ohio Penitentiary, and in the evening a theatre party. After the announcement, adjournment was taken until 9 o'clock the next morning.

Report to be concluded in July.

#### Comparative Volume of Air.

The large air pump finds favor in heavy passenger service quite as much as it does in heavy freight, although it might seem at first thought that the passenger locomotive could get along comfortably with a smaller pump than is required for the freight. A little reflection—and calculation—will show, however, that a modern passenger train consisting of ten moderately heavy cars requires as much air to operate its brakes as is required by a freight train of nearly four times the number of cars.

The capacity of a 16 by 33-inch auxiliary reservoir is about 3,900 cubic inches, and that of an 8-inch freight auxiliary about 1,600 cubic inches, so that the passenger auxiliary has nearly three times the capacity of the freight.

To charge one of the 16 by 33-inch reservoirs to 110 pounds pressure requires about 29,250 cubic inches of free air, and to charge ten of them to this pressure requires 292,500 cubic inches.

To charge an 8-inch freight auxiliary to 70 pounds pressure requires approximately 8,000 cubic inches of free air, and from this it may be seen that the quantity of air required to charge the ten auxiliaries to 110 pounds pressure would be sufficient to charge 36 8-inch freight auxiliaries to 70 pounds pressure.

The capacity of a 16-inch by 42-inch reservoir, such as is used with the 16-inch brake cylinder, is about one-third greater than that used with the 14-inch brake cylinder. Hence, if the cars were equipped with 16-inch instead of 14-inch brake cylinders the air required to charge their reservoirs to 110 pounds pressure would be sufficient to charge forty-eight 8-inch auxiliaries to 70 pounds.

From the above it may be seen that the big pump on long passenger trains does not have to remain idle much of the time if stops are numerous.

In addition to supplying the brake system with air it must also take care of the air signal and the water raising systems, which make a slight additional demand not required of the freight engine's pump.

#### Packing Rings and Air Valves.

As the demand on the pump for air increases, the proper fitting of packing rings in the air pistons becomes a matter of more than ordinary importance; and so, also, does the correct lift of the air valves. This in order to prevent pump failures on the road.

It is a noticeable fact that where careful attention is given to the accurate fitting of air piston packing rings, and to the careful regulation of the lift of air valves, the pumps run much longer in hard service without signs of weakening than they do where these things are indifferently attended to, or

perhaps are almost entirely overlooked.

Some time ago we had occasion to inspect a number of pumps that had failed in service on the road, causing in nearly every instance an engine failure, and in each case the packing rings in the air pistons, and the air valves and their seats and cages, were found in a deplorable condition.

That is, the rings were very loose in their grooves and they were worn down to a thinness much beyond the limit of good practice; while the air valves were worn, and they had pounded and battered their seats out of all semblance to their normal shape.

When packing rings and air valves leak considerably, a hot, pounding pump is sure to result, if it is worked at all hard, and hence all the reason needed for a pump failure is present.

As things are regarded nowadays, a pump failure entails an engine failure. The prevention of such failure seems to lie largely in the hands of the roundhouse inspector. He can, by careful and thorough inspection and testing of the pump, before the engine leaves the roundhouse, ascertain its condition and determine upon its fitness to make the trip or not.

Unusual clicks and pounds are usually the warnings given that all is not right, and that a rigid examination of the internal parts is in order.

An efficient record system kept of each pump, where and by whom it was last overhauled, followed by the daily record of the roundhouse test, made by the inspector, will generally result in preventing pumps from failing on the road.

This inspection and test should be accompanied with ordinary care on the part of those who run and operate the pumps out on the road. That is by careful attention to starting them as they should be started, and running them at the recommended speed, which is inside the limit of racing, and then looking to the lubrication of both steam and air cylinders.

Air pumps to-day have about five times the work to do that they had a few years ago; therefore they are entitled to a little more attention and to better care on the part of all concerned.

A man who was recently re-elected to a position that he had held for many years, met a friend who congratulated him on his continued good fortune. To this the other replied: "Yes, but it can't always last; I'll have to give it up some day. I feel a great deal like a man I knew who worked on a railway for forty years, and when pensioned at last on account of old age remarked: 'Well, when I came here I knew I wouldn't have a steady job.'"

# Electrical Department

## Elementary Principles of Dynamos. III.

A variable resistance is always placed in series with the shunt field winding, or the separately excited field winding where such a winding is used, in a generator, as shown in Fig. 14, so that by varying this the resistance of the field circuit and hence the strength of the current through it, is also varied. Such a variable resistance is called a *field rheostat*. Decreasing the current through the field winding decreases the strength of the magnets and hence decreases the voltage of the gener-

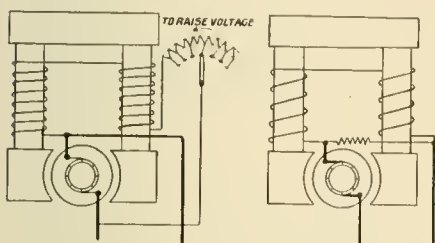

FIG. 14 WITH FIELD RHEOSTAT. FIG. 15 RESISTANCE IN PARALLEL.

ator, while on the other hand increasing the current in the field windings increases the voltage. The use of a field rheostat enables the voltage of a generator to be maintained at its proper value in spite of minor variations from the exact conditions for which the machine may have been designed or in spite of ordinary variations in manufacture.

A field rheostat can not be used with a series wound generator because the entire current from the machine in such a case flows through the field winding and the introduction of a resistance in series with the field winding to reduce the current through it would reduce also the current in the outside circuit. In such machines, however, the same effect may be obtained by placing a resistance in parallel with the field winding, as shown in Fig. 15, so that only a part of the total current of the machine will flow through the field winding while the remainder passes through the resistance to the outside circuit without having any effect on the strength of the field magnets. Such a resistance is called a *shunt*.

In considering the construction of dynamos so far, we have mentioned only the number of turns of wire on the armature. The size and material of this wire, that is its resistance and carrying capacity, are also important matters. It has been explained elsewhere that to force a current of any given value through any particular wire, a certain voltage is re-

quired, depending on the resistance of the wire. In any dynamo, therefore, a part of the e.m.f. generated is required to force the current through the armature winding itself. Hence the smaller the resistance of the winding the smaller is the part of the total e.m.f. required to send the current through the armature itself and hence the greater the efficiency of the machine.

The product of the current in amperes by the volts required to send it through the winding, moreover, represents energy in watts which is lost in the winding and which appears as heat. This heat tends to raise the temperature of the winding and if the resistance of the winding is too great or its carrying capacity too small the temperature may become so high that the insulation on the wire may be destroyed or the wire melted.

In all of our explanations heretofore we have considered only dynamos having two field magnet poles, one north and one south. Such machines are called *bi-polar* machines, the prefix *bi* signifying two. The construction of dynamos is not at all limited to such an arrangement, however. Electro-magnets can be made having four, six, eight or any even number of poles, and by properly arranging armature winding, commutator and brushes dynamos using such magnets can be built. Such machines are called *multi-polar* machines, the prefix *multi* meaning many.

Fig. 16 shows a four pole magnet of this sort, together with the core of a ring armature. By using the thumb and fingers of the right hand as described in Part I of this series to determine the direction of the e.m.f. generated, it will be seen that a wire in passing from the point A to the point B will have generated in it the same cycle of e.m.f. in one-half of a revolution of the armature as in a complete revolution of the armature of a two pole machine.

### Block Signal Designs.

A recent press dispatch from New Orleans says the block signal system is to be installed on the New Orleans & Northeastern. A try-out of six designs submitted will be made on a 40-mile stretch of hilly country between Hattiesburg and Derby, Miss. After one has been adopted, the line will be equipped from New Orleans to Meridian, 196 miles, and from Meridian to Shreveport, 310 miles, thus practically covering the Queen & Crescent system through to Cincinnati.

## Electrical Laws and Units.

The laws and terms relating to the flow of electricity may often be more easily explained and understood by comparing them with similar ones relating to the flow of water. It is well understood that water will flow from a high level to a low one, and that a difference in level between two bodies of water always indicates a possibility of doing work by allowing a stream, or current of water to flow between them. The term *potential* has the same general significance, speaking electrically, as level has in the case of bodies of water and a *difference of potential* corresponds to a difference of level. Whenever there is a difference of potential between two bodies, there is always the possibility of doing work electrically by allowing a current of electricity to flow from the higher potential to the lower one. There is a difference of potential between the two terminals of a battery or a generator, and the terminal which is at the higher potential is called the *positive terminal* and is usually indicated by the plus (+) sign. The terminal which is at the lower potential is called the *nega-*

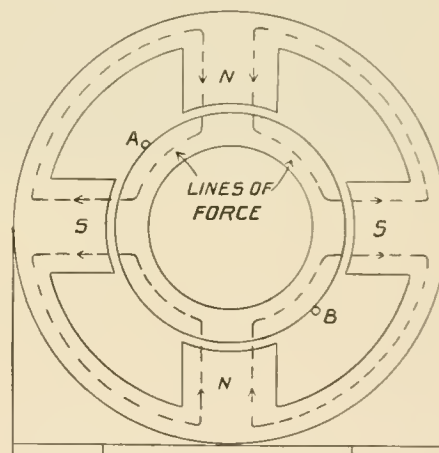

FIG. 16. FOUR-POLE MAGNET MACHINE.

*tive terminal* and is indicated by the minus (—) sign.

The term *electromotive-force* (commonly abbreviated e.m.f.) is frequently used instead of difference of potential, so that there is said to be an e.m.f. between the terminals of the battery or generator. Strictly speaking however, the e.m.f. exists on account of the difference of potential, just as a pressure exists in a water pipe on account of a difference of level.

Difference of potential or e.m.f. is

expressed in *volts*, the volt being the unit of measurement in the same way that the foot is the unit of measurement for difference of level.

By putting mechanical work into a pump, a pressure (or practically a difference of level) may be created. In the same way, by putting mechanical work into a generator, or chemical work into a battery an e.m.f. may be generated.

The pressure which is required to force a given quantity of water through a particular pipe in a certain time, depends on the length and diameter of the pipe, and upon its general condition as to straightness, inside surface, etc. In the same way the e.m.f. required to force a given quantity of electricity through a particular wire depends upon the length, cross section and material of the wire.

There is no particular unit for expressing the resistance which a pipe offers to the flow of water, and this can be done only in a more or less round about way, but electrical engineers have agreed upon and various governments have adopted a certain standard unit of electrical resistance called the *ohm*, in terms of which the resistance of any body may be expressed. The ohm is represented by the resistance at zero degrees centigrade of a column of pure mercury of uniform cross section, 106.3 centimetres long and having a mass of 14.4521 grammes. The electrical resistance of any object is said to be so many ohms or such a fraction of an ohm, according to whether it is more or less than the above standard.

The rate at which water flows through a pipe is ordinarily expressed in terms of the quantity which flows in a given time; that is, so many gallons, or so many cubic feet, per minute or per second. This is done because the flow can be readily measured in terms of these quantities, and in dealing with the flow of water these items are the ones which it is usually desired to know. The rate of flow of electricity in a wire may be expressed in a similar way as so many *coulombs* per minute or per second, the coulomb being the unit of quantity of electricity the same as the gallon or the cubic foot is the unit of quantity of water. The rate of flow of electricity, however, is not ordinarily expressed in this way. The nature of electricity is such that it is usually more convenient to deal with the rate of flow directly than with the quantity which passes in a given time.

If two metallic plates, one being of silver, are dipped into a solution of nitrate of silver and a current is passed through the solution from the silver plate to the other plate, the silver plate

will be gradually eaten away and the silver which is taken from it will be deposited on the other plate. The rate at which the silver will be deposited in any given case depends on the strength of the current, and such an apparatus forms an accurate method of determining the strength of any current. It has been agreed among electrical engineers that a uniform current which will deposit silver in this way at the rate of .001118 grammes per second shall be considered as the unit for expressing the *rate of flow* of electricity. Such a current is called an *ampere*.

The unit of *quantity* of electricity which has been referred to above as the *coulomb* is that quantity which passes due to a current of one ampere flowing for one second. It is thus evident that the rate of flow may be expressed, as in the case of a stream of water, as so many coulombs per second (one coulomb per second being equivalent to one ampere). Ordinarily, however, instead of doing this the flow is stated directly in amperes.

It has already been mentioned that the unit of e.m.f. is the *volt*. This is defined as that pressure which is required to force a current of one ampere through a circuit having a resistance of one ohm.

The volt, the ampere and the ohm are the three fundamental electrical units in common use, and it is essential that their meaning should be fully understood. As a means of fixing their values in terms of ordinary things it may be mentioned that the e.m.f. at the terminals of the usual 16 candle incandescent lamp is, as a rule, from 100 to 110 volts, and the current flowing through it is approximately half an ampere, while a No. 10 B. & S. gauge copper wire (.102 inch in diameter) 1,000 feet long has a resistance of almost exactly one ohm.

#### Conductivity and Resistance.

One of the fundamental laws upon which the various applications of electricity are based is the relation between the current in any electrical circuit, the resistance of the circuit and the e.m.f. or voltage at the terminals. This relation was first discovered by Dr. G. S. Ohm, who stated it in the following law which has since been known as Ohm's law: *The current varies directly as the electro-motive force and inversely as the resistance of the circuit.*

From the definition of the volt which has been given elsewhere as the pressure required to send a current of one ampere through a resistance of one ohm, it follows at once from the above law that: The pressure in volts on any electrical circuit divided by the resistance of the

circuit in ohms is equal to the current in amperes, which flows. Thus, with an e.m.f. of 100 volts and a resistance of 200 ohms, there would be a current of half an ampere.

Ohm's law is usually expressed by the formula  $C = \frac{E}{R}$ , where C is the current in amperes, E the e.m.f. in volts, and R the resistance in ohms. This formula may be written equally well  $E = RC$ , or  $R = \frac{E}{C}$ , indicating that if the resistance of the circuit and the current flowing are known, the voltage may be found by multiplying them together, or if the voltage and current are known, the resistance may be found by dividing the former by the latter. Thus, if we know that in a certain circuit there is a current of ten amperes flowing through a resistance of five ohms, we can readily calculate that the e.m.f. at the terminals of the circuit must be 50 volts, or if we know that an e.m.f. of twenty volts will send a current of five amperes through a certain wire, it is evident at once that the resistance must be four ohms.

Intimately connected with Ohm's law is the law of parallel circuits. The opposite of resistance is called conductance or conductivity. If a wire offers a great resistance to the passage of an electric current, it is said that its resistance is high, or that its conductivity is low. Thus the conductivity of a wire is the reciprocal of its resistance. For instance, if the resistance of a given circuit is six ohms, its conductivity is said to be  $\frac{1}{6}$ th.

If two wires are connected in parallel, their combined conductivity is the sum of their individual conductivities, and their combined resistance is the reciprocal of this. Their combined resistance, therefore, is the reciprocal of the sum of the reciprocals of their individual resistances. Thus if  $r'$  represents the resistance of first wire and  $r''$  that of the second, then the conductivity of the first will be  $\frac{1}{r'}$

and that of the second  $\frac{1}{r''}$ . The combined conductivity will be  $\frac{1}{r'} + \frac{1}{r''}$ , or  $\frac{r' + r''}{r' r''}$ . The combined resistance, therefore, will be  $\frac{r' r''}{r' + r''}$ . It is evident

that if the two wires or circuits are exactly alike the total conductivity will be double and the combined resistance will be one-half that of either wire alone. This same principle may be applied to any number of wires or circuits in parallel.

If two or more circuits are connected in parallel to a source of constant e.m.f. the total current which flows will depend on the combined resistance of the entire circuit. This current will divide

between the several circuits in inverse proportion to their resistances, the circuit having the least resistance taking the greatest current. Thus, if a 16-candle power incandescent lamp, having a resistance of 200 ohms, and a 32-candle power one having a resistance of 100 ohms are connected in parallel on a circuit having an e.m.f. of 100 volts, the

combined resistance is  $\frac{100 \times 200}{100 + 200} = 66\frac{2}{3}$  ohms. The total current is  $\frac{100}{66\frac{2}{3}} = 1\frac{1}{2}$

amperes. Since the 32-candle power lamp has a resistance of only half that of the 16-candle power, twice as much current will pass through it, or one-third of the total current. Therefore, one ampere will flow through the large lamp and one-half an ampere through the small one.

#### Tunnel Under the Detroit River.

A tunnel is being built under the Detroit River for the transference of both freight and passenger trains between the United States and Canada on the Michigan Central Railroad. The tunnel will replace the present ferry service between Detroit on the American shore and Windsor on the Canadian side of the river. Two tracks will be laid in separate iron tubes 65 feet beneath the surface of the river. These iron tubes will rest on beds of concrete and will be flanked by concrete walls. The electrified zone will be 4.6 miles in length and will comprise with the yards some 15 miles of single track.

Electricity will be used as a motive power, and the electric locomotives will afford a complete solution of the ventilation problem. Six 100-ton direct current locomotives of the swivel truck type, with geared motors, will comprise the initial equipment for hauling both freight and passenger trains. Each locomotive will be capable of hauling a 900-ton train up a 2 per cent grade at a speed of 10 miles per hour. Four 280 H. P. motors will be mounted on each locomotive, two motors being placed on each of the two swivel trucks. The Sprague-General Electric multiple unit control system will be furnished, enabling the locomotives to be operated singly or in train. Current for operating the motors will be taken from a third rail by means of contact shoes. Automatic, high speed air brakes will form a necessary part of the equipment. The electrical equipment for the locomotives, as well as for the tunnel in general, will be furnished by the General Electric Company.

A very complete electric lighting and electric pumping equipment forms a part of the project. The yards and approaches to the tunnel will be lighted by arc lamps, while the tunnel itself

will be illuminated by incandescent lamps, arranged on duplicate circuits. Alternating current from the main power supply will be used on the lighting circuits. To insure an uninterrupted lighting service the lighting circuits in the tunnels are so arranged that half the lamps in both tunnels will burn if by chance either of the lighting circuits in the tunnels should be broken. A single three-phase distributing circuit will run through each tunnel, and from these circuits suitable connections will be made to step-down transformers. The secondaries of the step-down transformers will be interconnected with duplicate circuits for half the lamps in each of the tunnels.

No less interesting will be the equipment for keeping the tunnel dry. Five sumps will be provided in the tunnel, each sump drained by induction motor

stalled to enable this interchange of power supply to be easily and quickly made.

#### Considering Electrification.

The Colorado and Southern Railroad is considering the electrification of its line from Denver to Boulder, a distance of approximately thirty miles. It is proposed to use the single phase system and to purchase the necessary power from the Northern Colorado Power Co., whose station is located about six miles from the line. According to the present plan the cars will be arranged to operate on direct current as well as single phase alternating current and will be run from Globeville into Denver, a distance of two miles, over the city streets, the same as the regular city cars.



OLD TIMERS ON THE CHEMIN DE FER DE L'EST, FRANCE.

centrifugal pumps arranged in duplicate. The motors on the pumps will operate directly at 4,400 volts, and the controlling circuits with compensators will be centralized in the sub-station. For indicating the amount of water in each sump, a float system will be provided, having both visible and audible indicating devices in the sub-station.

At the sub-station a regulating storage battery will be provided to carry the fluctuations of the load. If the main power supply from the Detroit Edison mains should be interrupted this storage battery will have sufficient capacity to operate the entire system for half an hour. In such an emergency the lighting and pumping alternating current equipment will be energized by 60 cycle, alternating current from a 50 kilowatt motor-generator set, the driving motor being supplied with current from the storage battery. Flexible switching arrangements will be in-

#### The Hague.

Amsterdam is the capital of Holland or of the Netherlands as the country is otherwise called, but the government business is transacted at The Hague. A writer in one of the New York dailies, speaking of the origin of The Hague, says:

"For historical reasons which date back to the days of the 'graafschappen' (countships) The Hague was chosen by those reigning counts as their residence. The name The Hague signifies 'the counts' parks,' or, literally translated, the counts' hedge."

This probably accounts for the fact that the specific article "the" is always placed before the name of that city. The constitution requires the Queen of Holland to visit Amsterdam once a year for at least five consecutive days, and the coronation of sovereigns must take place at the capital.

Phillips Automatic Train Control.

The report recently issued by the Interstate Commerce Commission as to the block system suggests among other safeguards an automatic train control whereby trains can be automatically pulled up in case they run by a



SIGNAL TOWER EQUIPMENT.

signal at danger. Judging also from the experience on British railways, there seems to be a field for such a safety appliance in that country, and it would have the further advantage there of probably meeting the foggy conditions they have to contend with.

Automatic train controls are not unknown in this country as they are used

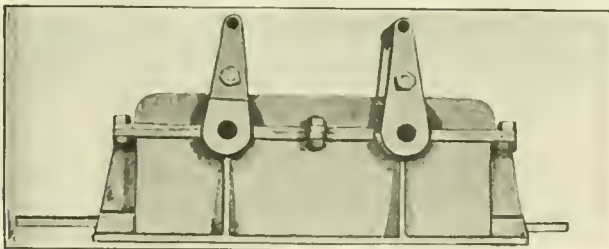

FIG. 2. TRACK EQUIPMENT, PHILLIPS SYSTEM.

on the express tracks of the New York Subway, the Boston Elevated and the Philadelphia Subway. These are, however, all electrically operated roads, which are more or less protected as far as weather conditions are concerned.

The idea in the Phillips automatic train control is of a dual nature—it checks the train at the distant and halts it at the stop signal. It gives a visual or audible indication or both. It is capable of being released without the engineer leaving the footplate. A record is also obtainable for showing when the apparatus is used at a stop signal, that is, when an engineer runs by such a signal at danger. We are

able to present illustrations of this automatic train control installation that has been in use for some time on the North Staffordshire Railway in England. The introduction of this system on American roads is being arranged.

On the track there is placed a tripper at the distant and at the home or other stop signal. This is shown in position in Fig. 1 and in detail in Fig. 2. On the locomotive, between the life-guards, or downward projecting bars which are attached to the buffer beam, over the rails, there is, as shown in Fig. 3, an iron case, illustrated by Fig. 4. Passing through the bottom of this case are two levers. The apparatus on the track is staggered so that the distant tripper strikes one lever and the stop tripper strikes the other lever. Should the signal be lowered, the trippers are also lowered clear of the locomotive mechanism. If, however, the signal is "on," then the corresponding lever is struck and turned, which allows a horizontal lever to fall and open the brake

pipe so that the brake is applied. In the case of a distant signal the application is only gradual and can be readily overcome by the engineer, but in the case of a stop signal the application is full and, as was demonstrated on the North Staffordshire Railway recently, a train running at full speed with steam on was pulled up in a very short distance. Indicators are provided on the locomotive to show whether the application is at a distant or a stop signal and between them is a three-way cock which has to be turned before the brake can be released. The syren or trumpet on the right side of the cab, Fig. 5, is sounded by air pressure on all occasions when the trippers are struck and continues to do so until the engineer has taken action.

It will be noticed in Fig. 2 that there are two trippers. These work together, but the second is only intended as a reserve. Referring again to Fig. 4 it should be said that each lever is made in two parts working on the same shaft and held together by a lug at the bottom. Above the shaft is a spring in compression. Should the levers get broken the spring would force the upper parts open and the horizontal lever would fall into the recess which has been provided and thus automatically apply the brake. This is to safeguard an engineer from proceeding in ignorance of a mechani-

cal failure which would otherwise lead to his getting "clear" signals. When the track apparatus is operated from a tower a repeater instrument is provided which shows the state of the trippers and if they are moved by a passing train or maliciously or accidentally disturbed, a bell rings in the tower and continues ringing until stopped. This provides for any failure of the trippers. The apparatus shown has been designed for the vacuum brake, as

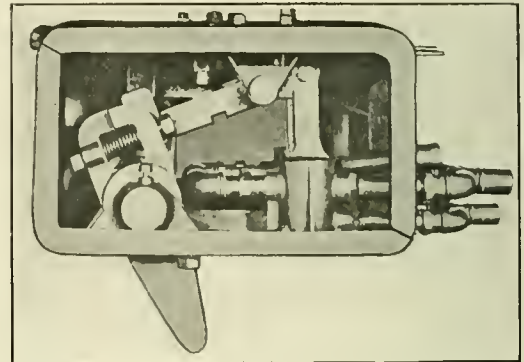

FIG. 4. ENGINE EQUIPMENT, PHILLIPS SYSTEM.

used in England, but it has been altered for the air brake and modified to suit American conditions.

Fitting a Saddle.

In a recent visit to one of the great locomotive construction works it was observed that mechanical appliances had reached such an infinite variety of uses that machinery seemed to be doing everything except perhaps chipping a saddle. The air hammer is now getting its work in on this also. The chipping of a saddle, like the shoeing of a horse, is likely to remain a portion of the world's work where handicraft cannot be superseded by mechanical devices. Chipping a sad-



FIG. 1. TRIPPER ON THE TRACK.

dle must be done so that there is an exact fit of the smoke box and the saddle. In setting valves and other fine work, deficiencies may be concealed. There is no method of concealing the fit of a saddle. The joint must be the real thing.

The methods of operation vary according to the kind of saddle and the class

of frames. In any case, if it is at all possible, it is best to have the frames and boiler levelled and the saddle set on such supports as are readily adjustable. Generally the saddle can be readily rested

proceed to draw a line around the entire edge of the saddle bearing. The compasses must be held not only perfectly level, but the legs must at all points be in perfect plumb with each other.

mer is of use in finishing up and with the smoke box blackened by lamp black and oil it will be readily determined where the prominent places may be reduced and a fine fit completed.

In cases where it is not expedient to move the saddle, it will be found that in raising and lowering the boiler the same general precautions will apply, with this addition: that if the boiler remains pivotally stationary at the back, and it will necessitate making an added allowance of stuff to be removed from the front of the saddle, in view of the increasing arc formed by the extended path of the extreme boiler front, as the boiler is moved on a point at the rear.

#### Chilled Cast Iron Wheels.

Without the chilled cast iron car wheel the immense mileage attained by railroads on this continent would not have been possible. It has certainly been a great factor in the economical operation of our railways and in the evolution of the modern railway, the cast iron chilled car wheel has not been crowded out of existence. These thoughts were expressed by Mr. W. E. Fowler, Master Car Builder of the C. P. R., in a paper recently read before the Canadian Railway Club in Montreal.

He went on to say that a 600-lb. wheel costs \$10.80 when new, and that after giving a mileage of from 40 to

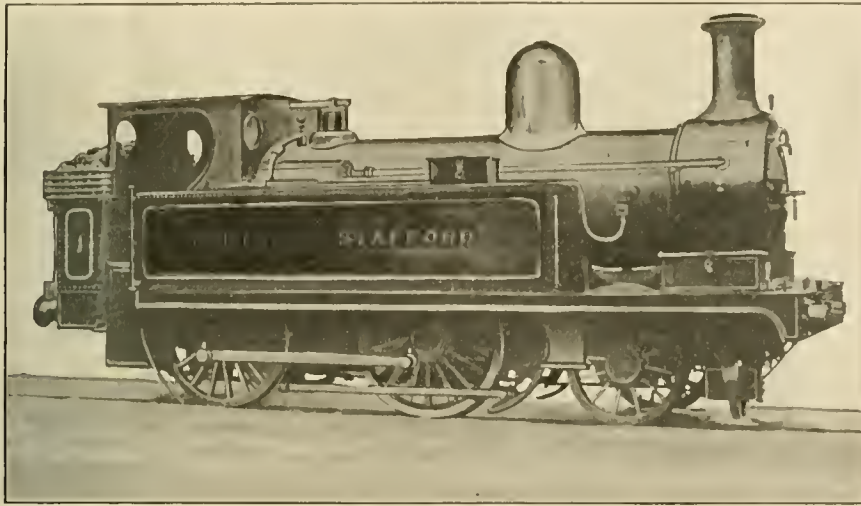

FIG. 3. NORTH STAFFORDSHIRE RAILWAY ENGINE EQUIPPED WITH PHILLIPS STOP SIGNAL APPARATUS.

on two portable rails set on wooden blocks. With a screw jack at each of the four corners the saddle can be raised until it barely touches the arch of the smoke box. The exact work begins here. The true position of the saddle can be readily determined by measurement at four points adjacent to the frames, and it must be particularly observed that the raising and lowering of the saddle does not affect the exact position of the semi-flexible frames. The best precaution to maintain the perfect relationship of the boiler to the frames is to hang a loaded string over the arch of the boiler and see that the distance from the frames to the string remains the same.

It is generally discovered that the saddle bearings will strike the smoke box in the lower part of the arc, leaving the two points slightly open. It is immaterial where the nearest contact occurs. It is certain that there is always a considerable amount of matter to be removed from the saddle, and when the saddle is set with great care it should be temporarily clamped to the frames and also sustained in place by hardwood wedges, as screw jacks, unsupported, are apt to oscillate with little disturbances. The edges of the saddle approaching the smoke arch should be chalked firmly, and the amount to be chipped should be marked off with a large pair of sharp pointed compasses. Some mechanics use callipers with one straight and one bent leg. Others make small templates with projecting points. Long-legged compasses are preferable, and supposing the amount to be taken off amounts to say one inch at the thickest part, the best practice is to set the compasses at one thirty-second less than the required amount and

When the line is completed it is good practice to examine it at different points with much deliberation, pausing with the compasses and proving the absolute accuracy of the marking. The saddle can then be dropped to the rails and moved from under the boiler. The line should be carefully marked with a centre punch, and the operation of chipping should be

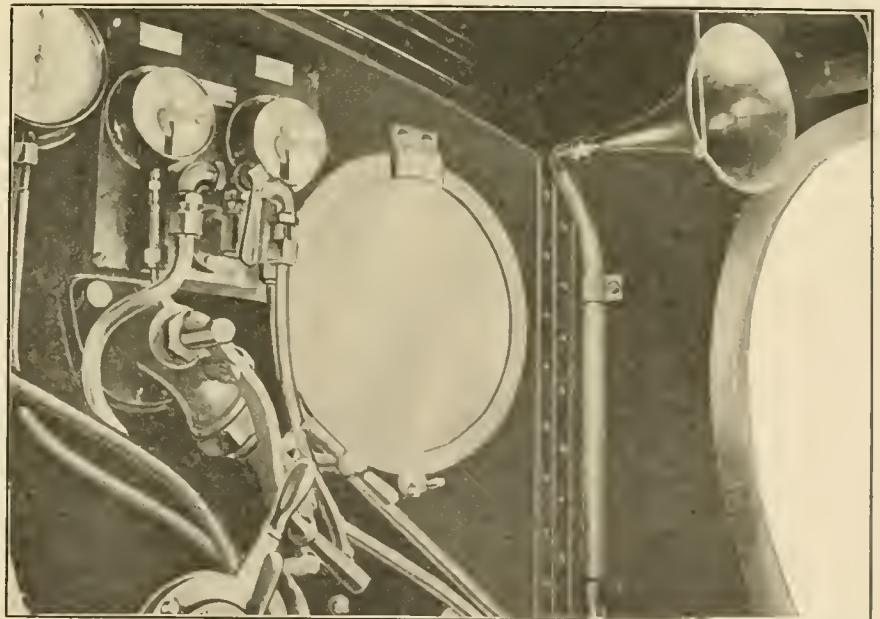

FIG. 5. CAB EQUIPMENT OF THE PHILLIPS AUTOMATIC STOP SIGNAL SYSTEM.

begun by cutting narrow grooves in the casting down to the line. The grooves may be from an inch to an inch and a half apart, and when the grooves are cut the remaining uncut spaces can be readily struck off with a blacksmith's cold chisel with handle, sometimes called a cleaver, and a sledge. The air ham-

mer is of use in finishing up and with the smoke box blackened by lamp black and oil it will be readily determined where the prominent places may be reduced and a fine fit completed. In cases where it is not expedient to move the saddle, it will be found that in raising and lowering the boiler the same general precautions will apply, with this addition: that if the boiler remains pivotally stationary at the back, and it will necessitate making an added allowance of stuff to be removed from the front of the saddle, in view of the increasing arc formed by the extended path of the extreme boiler front, as the boiler is moved on a point at the rear.

Without the chilled cast iron car wheel the immense mileage attained by railroads on this continent would not have been possible. It has certainly been a great factor in the economical operation of our railways and in the evolution of the modern railway, the cast iron chilled car wheel has not been crowded out of existence. These thoughts were expressed by Mr. W. E. Fowler, Master Car Builder of the C. P. R., in a paper recently read before the Canadian Railway Club in Montreal.

He went on to say that a 600-lb. wheel costs \$10.80 when new, and that after giving a mileage of from 40 to

70 thousand miles, it is turned back to the foundry at a scrap value of about \$7.80. This makes a cost of about five cents per thousand miles. In early days there were the single plate wheels, some with and some without spokes or ribs; some were corrugated and some were plain.

Double plate wheels there were of many sections, and both single and double plate wheels were made in all sizes from 30 to 42 inches in diameter, with long hubs and short hubs, some having their greatest projection beyond the outside, and some beyond the inside, with width of tread and thickness of flange varying, though not widely, until the Master Car Builders' Association succeeded in getting adopted a standard wheel diameter, standard section of tread and flange, a standard of hub length, and a standard diameter of wheel seat for each size of axle. Mr. Fowler might have mentioned that years ago the Grand Trunk and other lines had some wheels of very wide tread which were called "compromise" wheels, and these were intended for service on tracks of slightly different gauge.

Continuing, the speaker said: "We are now in possession of all the benefits derived from the adoption of these standards, and it is hard to believe that there are some railroad officials to-day who do not appreciate what the M. C. B. Association has achieved in this and in other matters, and what may yet be done."

Until a few years ago the wheel foundry was laid out in circular floors, each floor being served by a jib crane set in its centre. The circular floor was not economical of space, and it is rapidly giving way to the electrically operated foundry, laid out in rectangles. The floors, as in the Angus shop, on the C. P. R., are laid out in parallel lines with nine-foot centres, each with a capacity of twenty wheels. The hot metal is carried in buggy ladles along one end of these floors and the finished hot wheels are removed by lorries along the opposite ends, the floor itself being served by an overhead crane. One end of the shop is devoted to the pits for annealing the wheels, the stacking floor to receive them after being removed from the pits.

The manufacture of wheels commences at the breaker, where old car wheels, to the extent of from 40 to 60 per cent. of the weight of the new wheels turned out, are broken by the big drop weight, the foreman carefully inspecting the broken pieces, so that he may determine what proportion and variety of pig shall be used with each charge. The hot wheels are placed in the annealing pits as soon as practicable, that is as soon as cool enough to handle without danger of injury. The wheels remain in these pits for four days cooling slowly and uniformly, and are generally as hot as can comfortably be handled when they are taken out. After this they are cleaned, inspected, taped, and tested,

representative wheels from each batch being taken for this purpose.

The thermal test is the only one applied at the Angus shops. Cracked plates, cracked brackets, shelled out spots, worn flat spots, and treads worn hollow are defects of manufacture. These can be avoided by putting better material into the wheel, and giving more careful attention to its manufacture. Worn flanges are generally traceable to trucks which do not curve easily, couplers without sufficient lateral clearance, cutting by brake shoes, and inaccurate mating of wheels.

Proper care is seldom given to the mating of wheels, and this is evidenced by destructive flange wear and increased load on the engine. Until recently, the part played by the brake shoe in flange wear had been given too little attention. Credit was given to the Air Brake Men's Association for having called attention to this point. Too little attention has been given to the proper hanging of brake beams, to the proper centering of brake heads with relation to the tread of the



ROLLED MERCHANT BAR SHOWING ORIGINAL COMPOSITION.

wheels, and to the uniform length of brake hangers. Any of these defects result in poor breaking service and injury to the wheel. A brake shoe when first applied may overlap the rim of the wheel ever so little, but with each reduction of its thickness in service the lap will increase, and the brake shoe on the other end of the brake beam will be forced more and more against the flange of the wheel, and this will gradually bring about the condition described as worn flange.

The value of the cast iron wheel in railroad service lies unquestionably in the wearing qualities of its tread, the more than steely hardness of which gives greater mileage for the same amount of wear, or metal removed in service, than any other wheel in existence. Not only does the cast wheel carry heavy loads over steel rails made as hard as they can be without danger of breaking, the wheel also withstands with comparative freedom from failure the tremendous friction of the brake shoes when making stops from high speed, or when descending long, heavy grades.

The design of the present wheel is a matter of evolution. The amount of iron in the hub has been determined

not only by what is required to stand the pressure in mounting the wheels on the axles without fracture, but also that necessary to withstand the force exerted by the brakes when a stop is being made, as this force tends to loosen the wheel on the axle. Experience, the safest and best teacher, has had a hand in this important work, and there is practically no dissent from M. C. B. standard practice to-day.

In the matter of flange failures during the past few years the M. C. B. Association became convinced that they were not due to any special foundry mixture or confined to the wheels of any particular maker. At the last convention the committee who had this matter in charge, recommended that the thickness of the flange be increased  $\frac{1}{8}$  of an inch when measured at the gauge line, this increased thickness tapering to nothing near the apex of the flange. The Maintenance of Way and the American Railway Associations concurred in the recommendation and the thicker flange has since been adopted by the Master Car Builders' Association by letter ballot, and the benefits of this improvement will soon be apparent.

#### "Merchant Bar Iron."

The illustration which we give here is reproduced from what is called a "merchant bar." It is steel, and the end has been carefully etched, and the illustration shows the full size of the bar. The result shows that the bar, which is octagon in shape, was rolled from a "pile" made of steel rails. Though rolled the rails have retained their original outline. The evidence of the structure of the bar is plain to be seen, and it shows that the rolling of this bar did not produce very satisfactory welds, and the conclusion is naturally reached that this is but a sample of many such cases. We received the etching from a motive power officer of one of the largest railways, and it is also evidence of the value which the testing department of a railway does in connection with bought material.

In the near future the Interstate Commerce Commission is to appoint a committee of experts to investigate and experiment with all the block signal and related systems for preventing train accidents, and to make complete and detailed report thereon, with a view to action that will establish the best possible protection against wrecks.—*N. Y. Commercial.*

We have all got to travel through Vanity Fair, and we had better learn the rules of the road from the best masters.—*L. H. M. Soulsby.*



# Items of Personal Interest

Mr. George H. Daniels, the well known advertising manager of the New York Central Lines, has retired from the active administration of his department. He will still be connected with the department in an advisory capacity, and his large experience and knowledge of affairs will still be devoted to New York Central interests. Mr. Daniels began his railroad career in 1872, when he was appointed general passenger agent of the Chicago & Pacific Railroad. In 1880 he became general ticket agent of the Wabash, St. Louis & Pacific. Two years later he was appointed commissioner of the Colorado Railroad Association, and to this was added the Utah Railroad Association and then in rapid succession he held various traffic association positions until, in the early part of 1889, he was appointed general passenger agent of the New York Central, a position which he held with honor and ability for nearly seventeen years. Mr. Daniels has always been a firm believer in newspaper and magazine advertising, and in an address delivered before the New York State Press Asso-



GEORGE H. DANIELS.

ciation a few years ago, he made the point that the railroad is the advance agent of commerce, and that railway advertising has been of immense value to American manufacturers in calling the attention of the whole world to the excellent work done by our inventors and mechanics, and it is this broad-minded policy which he has put into practice that has made his name so well known to railroad men and to the travel-

ing public. It is pleasing to know that although Mr. Daniels has given over the arduous and active side of the work, he still continues connected with the office he has held and that his wise councils will still be heard in the advertising department of the road he has so long, so faithfully, so actively served.

Mr. W. H. Maddocks has been appointed assistant superintendent of machinery and equipment for the Missouri, Kansas & Texas Railway, with headquarters at Parsons, Kan., to succeed Mr. Wm. O'Herin.

Mr. M. F. Beuthring has been appointed foreman of the car shops of the International & Great Northern Railway at Houston, Tex., vice Mr. Martin Ryan, resigned.

Mr. R. M. Boldridge, formerly master mechanic of the Mississippi Central, has been appointed master mechanic of the Central of Georgia, with headquarters at Cedartown, Ga.

Mr. P. J. Colligan has been appointed acting master mechanic of the Chicago, Rock Island & Gulf, with headquarters at Fort Worth, Tex., vice Mr. J. E. Holtz, resigned.

Mr. I. W. Smith has been appointed master mechanic of the Great Northern at Crookston, Mont., vice Mr. R. H. Smith, transferred.

Mr. R. L. Stewart has been appointed master mechanic of the Kansas City Southern, at Pittsburg, Kan., vice Mr. W. B. Dunlevy, resigned.

Mr. Hugh Montgomery, who for the past six years has been the general foreman of the Jersey City shops of the Central Railroad of New Jersey, has resigned to accept the position of assistant superintendent of motive power of the Bangor & Aroostook Railroad, with headquarters at Milo, Me. Mr. Montgomery is a Canadian by birth, having been born in London, Canada West, as the province of Ontario was then called. He served his apprenticeship on the Canada Southern, at St. Thomas, Ont. From there he went to the Chicago, St. Paul, Minneapolis & Omaha, where he worked for some time as a locomotive fireman. He subsequently took the position of locomotive engineer on the Chicago & North-Western, and on that line was promoted to the position of road foreman of engines, and later became general foreman. He was in all 12 years with the Chicago & North-

Western. On coming to the East he took the position of road foreman of engines on the Central Railroad of New Jersey, and was later promoted to the position he has just vacated. Mr. Montgomery comes of a family which were up and doing in the stirring times of the past. At the conclusion of the War of Independence, the Montgomery family divided themselves on political



HUGH MONTGOMERY.

lines. One branch of the family moved to Canada, as United Empire Loyalists, the other remaining in the United States as citizens of the new Republic. The subject of our sketch belongs to the branch of the family which moved to Canada. An uncle of Mr. Hugh Montgomery was the General Montgomery who led the unsuccessful attack on Quebec in 1775. The Canadian branch of the family, however, took part in the rebellion of 1837. A place known as Montgomery's Tavern, north of Toronto, was the rendezvous for the rebels who were led by William Lyon MacKenzie. It is, however, only fair to the rebels of 1837 to say that all their demands were subsequently granted by the British Government. Mr. Hugh Montgomery enters on his new field of work on the Bangor & Aroostook with the kindest expressions from the higher officials, and indeed everyone connected with the Central Railroad of New Jersey, and RAILWAY AND LOCOMOTIVE ENGINEERING joins with his wide circular friends in wishing him the greatest measure of success.

Mr. F. W. Williams, formerly master mechanic of the Delaware, Lackawanna & Western, has been appointed superintendent of motive power of the Chicago, Rock Island & Pacific, with office at Fort Worth, Tex.

Mr. H. C. Manchester has been appointed assistant superintendent of motive power of the Maine Central, with office at Portland, Me.

Mr. W. H. Sitterly has been appointed general car inspector of the Buffalo & Allegheny Valley division of the Pennsylvania Railroad at Buffalo, N. Y., vice Mr. S. M. Hindman, promoted.

Mr. J. W. Kelly has been appointed division freight agent of the Chicago & Eastern Illinois at Danville, Ill.

Mr. J. J. Hazel has been appointed master mechanic of the Broxton, Hazlehurst & Savannah, which has acquired the Ocilla & Valdosta, and he will have his headquarters at Ocilla, Ga.

Mr. E. S. Walker has been appointed master mechanic of the Peoria Railway Terminal Company, formerly the Peoria & Pekin Terminal Railway.

Mr. C. A. Snyder has been appointed master mechanic of the El Paso Southern, at Douglas, Ariz.

Mr. William Miller has been appointed superintendent of motive power and car departments of the Western Maryland Railroad, with headquarters at Union Bridge, Md., to succeed Mr. I. N. Kalbaugh.

Mr. Charles J. Laing, who was secretary to George H. Daniels while Mr. Daniels was general passenger agent of the New York Central, and continued in that capacity after Mr. Daniels became manager of the advertising department for all the New York Central Lines, has resigned and will become identified with the banking concern of Waterman, Anthony & Co., in the New Plaza Hotel. He was in the Central's service 21 years.

Mr. C. R. Dalby has been appointed tariff inspector of the New Orleans & Northeastern, the Alabama & Vicksburg and the Vicksburg, Shreveport & Pacific, at New Orleans, La.

Mr. R. C. White, formerly master mechanic of the Birmingham Southern, has been appointed master mechanic of the Birmingham Rail & Locomotive Co., of Birmingham, Ala.

Mr. W. Weatherspoon has been appointed foreman of the Communipaw shops of the Central Railroad of New Jersey, vice Mr. R. H. Nicholas, promoted.

Mr. F. A. Folger, formerly superintendent of the Kingston & Pembroke, has been appointed superintendent of the Canadian Northern, with office at Winnipeg, Man.

Mr. F. H. Ragan, formerly general foreman of the Lake Shore & Michigan Southern, at Ashtabula, has been appointed foreman of the erecting department of the Collinwood shops, on the same road.

Mr. B. F. Kuhn, formerly general foreman at West Seneca, has been appointed general foreman on the Lake Shore & Michigan Southern, at Ashtabula, O., vice Mr. F. H. Ragan, transferred.

Mr. F. L. Crandall, formerly foreman of the Lake Erie, Alliance & Wheeling, at Alliance, has been appointed general foreman on the Lake Shore & Michigan Southern at West Seneca, vice Mr. Kuhn, transferred.

Mr. Thomas J. Foley has been appointed superintendent of terminals of the Union Pacific Railway at Omaha, Neb.

Mr. Julius Krause, formerly foreman of car inspectors of the Pennsylvania's Pittsburgh division, has been appointed general car inspector of the Western Pennsylvania grand division.

Mr. D. E. Cassidy, formerly master mechanic of the old West Pennsylvania division, has been appointed assistant master mechanic of the Conemaugh division of the Pennsylvania.

Mr. J. C. Glass, formerly master mechanic for the Allegheny division at the Verona shops of the Pennsylvania, has been given supervision over the entire Conemaugh division, with headquarters at Verona, Pa.

Mr. R. C. White, formerly master mechanic of the Birmingham Southern, has resigned to go into other business.

Mr. G. B. Owen has been appointed engineer of maintenance of way on the Erie Railroad, with office at Jersey City, N. J., vice Mr. James Burke, transferred.

Mr. A. Schwartz has been appointed division engineer on the Erie Railroad, at Huntington, Ind., vice Mr. A. Crable, transferred.

Mr. J. B. Cozart has been appointed master mechanic of the Mexican Railway at Atizaco, Mex., vice Mr. E. L. Shipp, resigned.

Mr. F. H. Watts, formerly engineer of maintenance of way of the Vandalia Railroad, at Logansport, Ind., has been appointed engineer of maintenance of way at Indianapolis on the same road, vice Mr. A. R. Holliday, resigned.

Mr. R. H. Nicholas, until recently foreman in the Communipaw shops of the Central Railroad of New Jersey, has been made general foreman of the Mauch Chunk shops of the same road, vice Mr. David Weatherspoon, promoted.

Mr. David Weatherspoon, formerly assistant master mechanic at the Mauch

Chunk shops of the Central Railroad of New Jersey, has been appointed general foreman of the Jersey City shops, vice Mr. Hugh Montgomery, resigned.

Mr. Geo. L. Hagerty has been appointed road foreman of engines of the New York Central, with headquarters at East Buffalo.

Mr. H. C. Fleming has been appointed road foreman of engines on the Alabama Great Southern Railroad, with headquarters at Meridian, Tex., vice Mr. S. C. Parker, assigned to other duties.

Mr. J. M. Watson has been appointed road foreman of engines of the southern division of the Kansas City Southern Railway, with headquarters at Port Arthur, Tex.

Mr. B. C. Rich, formerly assistant chief engineer, has been appointed chief engineer of the Chicago, Indiana & Southern, with headquarters at Gibson, Ind.

Mr. E. A. Wescott has been appointed assistant mechanical superintendent of the Erie Railroad, with headquarters at Meadville, Pa.

Mr. A. C. Terrell has been appointed division engineer of the Northern Pacific, with headquarters at Spokane, Wash., vice Mr. L. S. Oakes, resigned.

Mr. Henry Manchester has been appointed assistant superintendent of motive power of the Maine Central, with headquarters at Portland, Me.

Mr. W. H. Dummert has been appointed locomotive foreman on the Canadian Pacific Railway, with headquarters at Chappleau, Ont., vice Mr. H. G. Reid, transferred.

Mr. H. G. Reid, formerly locomotive foreman on the Canadian Pacific Railway, at Chappleau, Ont., has been appointed master mechanic of the Lake Superior division of the same road, with headquarters at North Bay, Ont.

Mr. R. Ivers has been appointed locomotive foreman of the Grand Trunk Railway, with headquarters at Turcot, Que.

Mr. J. E. Whiteford, formerly general foreman on the Atchison, Topeka & Santa Fe at Fort Madison, Iowa, has been appointed general roundhouse inspector on the same road, with office at Albuquerque, N. M.

Mr. A. C. Adams, formerly master mechanic on the Lehigh Valley at Sayre, Pa., has been appointed master mechanic of the Alliance division of the Chicago, Burlington & Quincy, with office at Alliance, Neb., vice Mr. G. M. Reynolds, resigned.

Mr. E. Fisher has been appointed locomotive foreman of the Grand Trunk Railway, with headquarters at Belleville, Ont., vice Mr. J. R. Donnelly, promoted.

Mr. J. Hay, formerly locomotive foreman of the Grand Trunk Railway, at

Palmerston, Ont., has been transferred to a similar position on the same road at London, Ont.

Mr. T. H. Camp has been appointed district passenger agent of the Chicago Great Western Railway, with headquarters at Des Moines, Ia., vice Mr. L. M. Foss, resigned.

Mr. C. A. Doherty has been appointed division passenger agent of the Chicago Great Western Railway, with headquarters at St. Paul, Minn., vice Mr. Fred Wight, transferred.

Mr. Fred Wight has been appointed district passenger agent of the Chicago Great Western Railway, with headquarters at Omaha, Neb., vice Mr. F. H. Dunlop, resigned.

Mr. B. Tarkington has been appointed road foreman of engines and equipment of the Midland Valley, at Muskegon, I. T.

Mr. John E. Ward, vice-president of Gold Car Heating & Lighting Company, of New York, has decided to retire from the management of the Gold Companies for the purpose of engaging in the business of manufacturing and dealing in railway, steamship and contractors' supplies. About July 1st he will start on an extended trip abroad, and on his return will open offices in New York City.

Mr. E. E. Austin has been appointed master mechanic of the third district of the Pacific division of the Canadian Pacific, with headquarters at Nelson, B. C.

Mr. Frederick Mertsheimer, formerly superintendent of machinery of the Kansas City Southern, has been appointed superintendent of motive power and car departments of the Kansas City, Mexico & Orient, with headquarters at Sweetwater, Tex.

Mr. Wm. Miller, formerly master mechanic of the Denver & Rio Grande, at Denver, Col., has been appointed superintendent of motive power of the Western Maryland, with headquarters at Union Bridge, vice Mr. I. N. Kalbaugh, resigned.

The jurisdiction of Mr. J. W. Small, superintendent of motive power of the Arizona & Colorado, the Maricopa, Phoenix & Salt River Valley and the Gila Valley, Globe & Northern, with office at Tucson, Ariz., has been extended over the Phoenix & Eastern.

Mr. M. Parra has been appointed master mechanic of the Tampico Terminal, vice Mr. A. G. Kirchner, resigned.

The newly elected officers for 1907-1908 of the International Railway General Foremen's Association are as follows:

President, Mr. Elton F. Fay, General Foreman Union Pacific, Omaha, Neb.; First Vice-President, Mr. Lee R. Laizure, General Foreman Erie Shops, Hornells, N. Y.; Second Vice-President, Mr. Wm.



ELTON F. FAY, President International Railway Gen'l Foremen's Ass'n.

E. Farrell, General Foreman Big Four, Columbus, Ohio; Third Vice-President, Mr. J. J. Houlihan, General Foreman Wabash Railroad, Fort Wayne, Ind.;



C. A. SWAN, Retiring President International Railway Gen'l Foremen's Ass'n.

Fourth Vice-President, Mr. G. W. Keller, General Foreman Norfolk & Western, Portsmouth, Ohio; Secretary, Mr. E. C. Cook, 16 Sherman Street, Chicago, Ill.; Treasurer, Mr. Frank Hunt, General

Foreman Erie Railroad, Susquehanna, Pa.; Chairman Executive Committee, Mr. C. H. Voges, General Foreman New York Central Shops, Bellefontaine, Ohio. Members of the Executive Committee, Messrs. Edward C. Hanse, General Foreman Seaboard Air Line, Savannah, Ga.; Wm. Hall, General Foreman Chicago & North-Western Ry., Escanaba, Mich.; Luther H. Bryan, General Foreman Duluth & Iron Range, Two Harbors, Minn.; E. R. Berry, General Foreman C., B. & Q., Galesburg, Ill., and the Official Stenographer is Miss Julia Simons, 4911 Champlain Ave., Chicago, Ill.

**Obituary.**

A recent press despatch from London announces the death of Sir Benjamin Baker, one of the world's great engineers. It was he who invented the pneumatic shield which has rendered so much assistance in tunneling under rivers and through soft earth. The two great works by which he will be best remembered are the Forth Bridge in Scotland and the Assouan Dam on the Nile, of which he was joint engineer and consulting engineer, respectively. He was 67 years old.

The death of John A. Walker, vice president and treasurer of the Joseph Dixon Crucible Company, of Jersey City, N. J., has removed from the personal staff of that company a conspicuous and well known figure. Mr. Walker has been connected with this concern for forty years. He began as bookkeeper in 1867. He was a member of the Jersey City Board of Education in the eighties and of the Free Public Library Board from 1902 to 1905. He was vice-president of the Colonial Life Insurance Company, a director of the New Jersey Title Guarantee and Trust Company and a member of the Union League Club, the Board of Trade, the Cosmos Club, the Carteret Club and of the Lincoln Association. He was seventy years old at the time of his death and was a loved, honored and trusted officer of the Dixon Company, and his loss will be deeply deplored among not only his own wide circle of friends, but by all who had dealings with him in private or business relations.

It is with deep regret that we have to chronicle the death of Edmond Parker Lord, general manager of the well known H. K. Porter Locomotive Works of Pittsburgh, Pa. His death was the result of an accident which happened a few weeks ago when he was out riding in

company with a party of friends. His horse became frightened by a passing train, reared and fell backward on the rider. He was taken to the hospital and after several weeks had, as his friends believed, nearly recovered when death supervened. Mr. Lord was born near Boston, Mass., June 16, 1860, and was the son of John L. Lord. He was a graduate of Yale University in 1881, and afterward of the Stevens Institute of Technology at Hoboken. He entered the employ of the Pennsylvania Railroad and was successively located at Renovo, Pa., Altoona and Ft. Wayne, Ind., at the latter place as assistant superintendent of motive power of the Pennsylvania lines west. In 1892 he became superintendent of motive power of the Big Four Railroad. After remaining in that position

appointed engineer in the United States navy, and in 1845 became engineer-in-chief. He was the first man to receive this rank and he held that position until 1851. During those years he performed valuable service for the navy. He had charge of the designing of the machinery for ten ships, and introduced several mechanical improvements and was largely instrumental in bringing the steam navy of that time to a condition of high efficiency. The story is told that when the U. S. S. "Missouri" was fitted with horizontal smokestacks, Mr. Haswell was opposed to the plan and his expressed opinion involved him in a controversy with high officials of the navy. So tenaciously did he maintain his views that he was suspended from duty. The "Missouri" was tried with the horizontal smoke pipes which proved to be a dismal fail-

#### The General Foremen's Association.

The second annual convention of the International Railway General Foremen's Association was held at the Lexington Hotel, Chicago, from May 14th to May 17th, inclusive. The president, Mr. C. A. Swan, Jr., was in the chair. It had been originally intended that the association meeting was only to last three days, but on account of the interest taken in the subjects presented, and the full discussion that each was accorded, the period of meeting was extended one day longer. In view of the wide interest taken at this meeting, a resolution was unanimously passed that hereafter the convention each year should continue for a period of five days. The meeting all together was most successful. There were forty-seven regular members present, which is a considerable increase over the number which appeared last year. There were thirty-one active members elected at this meeting, fourteen associate members and one honorary member. This brings the active membership up to two hundred and ninety. The total associate membership is now forty-three, and there are also three honorary members. A very cordial vote of thanks was tendered to the outgoing president, Mr. C. A. Swan, Jr., for the untiring energy, time and labor which he has devoted to the interest of this important association.

#### Boiler Makers' Convention.

The joint convention of International Railway Master Boiler Makers and Master Steam Boiler Makers was called to order in the Convention Hall at the Hollenden Hotel, Cleveland, Ohio, at 10 A. M., on May 14th, by President C. H. Hempel, of the Union Pacific, Omaha, Neb. The Rev. Buehler Pratt, of the Euclid Avenue Church, made the opening prayer. In the absence of Mayor Johnston, the Rev. Harris M. Cooley, member of the Board of Public Service, welcomed the association to the city in a most cordial manner.

J. F. Deems, general superintendent of motive power and rollingstock of the New York Central lines, delivered one of his characteristic speeches, but prefaced his address with the request that the reporter take no notes. Mr. Deems' remarks were along the lines of shop practice, organization, and especially the training of the young men. He congratulated the convention on the good feeling that existed between the two bodies, and the prospective consolidation. His remarks were received with much enthusiasm. The opening session adjourned at 12 o'clock. In the afternoon the men visited the Collingwood shops of the Lake Shore & Michigan Southern Railway, while the ladies enjoyed a drive through the beautiful parks.



CHARLES HAYNES HASWELL AT HIS DESK.

for a year he came to Pittsburgh as superintendent of the H. K. Porter Locomotive works, remaining with that company ever since. He was a member of various clubs and societies in Pittsburgh and was for years president of the borough council of Edgeworth. He took an active interest in religious work and was a member of the Episcopal church. Edgeworth. He took an active interest in religious work and was a member of the Episcopal church.

The death of Charles Haynes Haswell at the age of 98 removes a prominent and remarkable figure from the engineering world. He was born in New York on May 22, 1809. At the age of 19 he entered the profession in which his name has become a household word. In 1829 he was employed in the boiler works of J. P. Allaire, one of the pioneer iron-masters of that day. In 1836 he was

ure, and the engineer-in-chief was subsequently given to understand that if he would apologize, he would be reinstated. He refused to apologize for his professional opinion which had been thoroughly vindicated, and he was later reinstated without having apologized. After leaving the navy he engaged in engineering work in New York and he was for upwards of forty years surveyor of steamships for the marine underwriters of New York. Besides his active work, Mr. Haswell was the author of two books, the most widely known being "Haswell's Pocket Book," which has passed through sixty editions. It is still in use as an engineering reference book. His other work was "Reminiscences of an Octogenarian," which is a book of memoirs covering the old New York from 1816 to 1860. His reputation was international and he received many flattering proofs of the regard in which his abilities were held by eminent engineers in other countries.

# Patent Office Department

## SUPERHEATER.

An improved superheating device has been patented by Mr. Francis J. Cole, New York, N. Y., and assigned to the American Locomotive Company, No. 849,052. As will be seen from the accompanying illustration the device embraces a combination with a tubular steam boiler, a T-head divided into supply and delivery compartments, superheating tubes, vertical saturated-steam headers communicating with and connected detachably to the supply compartment and having lateral tubular ears, vertical superheated-steam headers communicating with and connected detachably to the delivery compartment having lateral tubular ears, and pairs of superheater pipes located in the superheating tubes and connected at their front ends to ears on saturated and a superheated steam header. It will be observed that the device has the double merit of simplicity of construction while the joints are easily reached.

## TRIPLE VALVE.

Mr. R. A. Blackall, Edgewood Park, Pa., has patented an improved triple valve and assigned it to the Westinghouse Air Brake Company. No. 851,273. The device embraces a combination with a quick-action triple valve having means for increasing the brake cylinder pressure above that of the train pipe in emergency applications,

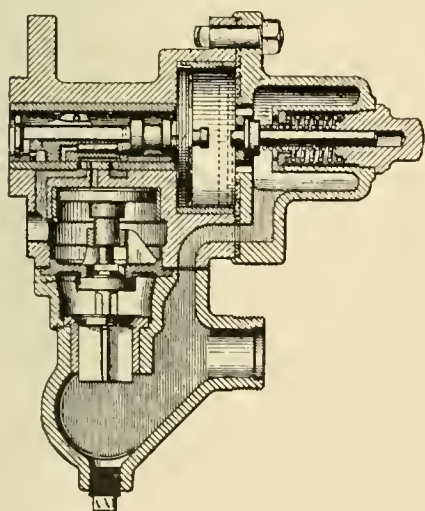

IMPROVED TRIPLE VALVE.

and means for gradually equalizing the fluid pressure upon opposite sides of the triple valve piston when the piston is in normal emergency position. A feature of the device is a small leakage groove in the wall of the triple piston chamber, and means for limiting the

movement of the piston to this position.

## CAR TRUCK.

Mr. A. F. Ostrander, Paterson, N. J., has patented an equalizing device for car trucks. No. 851,371. The combination comprises a car truck furnished

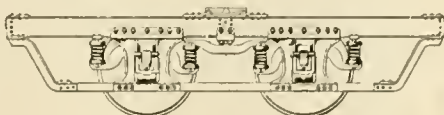

CAR TRUCK WITH EQUALIZERS.

with side frames having pedestals for receiving journal boxes and equalizer bars adapted to rest on the journal boxes, and coiled springs interposed between the outer ends of the bars and the side frames of the truck. There is a lever arranged at each side of the truck provided with a lug, a bearing secured to the side frame and engaging the lug, and yielding members in-

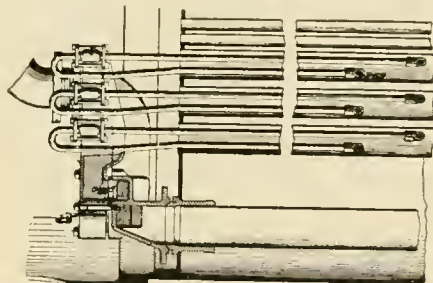

COLE SUPERHEATER.

terposed between the opposite ends of the lever and the inner ends of the equalizer bars.

## AUTOMATIC WHISTLE.

An automatic whistle has been patented by Messrs. W. M. Cox and A. M. Cox, Cythiana, Ky. No. 849,661. The combination embraces a whistle and its valve, a lever fulcrumed in proximity to the valve and provided with a finger with which it has a jointed connection, the finger being adapted to be moved into

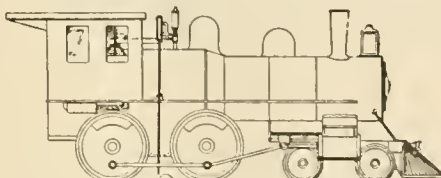

AUTOMATIC WHISTLE.

operative engagement with the valve when the lever is rocked rearwardly, and a trip-rod adapted to be rocked by a device along the track, the upper end of the trip-rod passing into the

space between the lever and its finger and arranged to engage the lever to rock it rearwardly when moved in one direction and to engage the finger of the lever when moved in the opposite direction.

## VALVE FOR ENGINES.

A valve for engines has been patented by Mr. Peder Paulsen, Pittsburg, Pa. No. 849,748. The device comprises

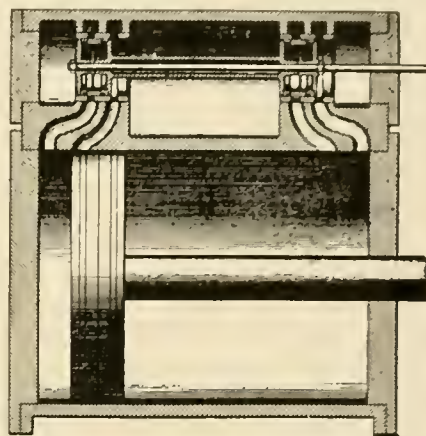

PISTON VALVE FOR ENGINES.

a valve having two heads and a connecting stem, the heads being separable from the body portion, with split rings supported by each of the heads, and solid rings arranged between each pair of split rings. There are also disks carried by one of the heads of each pair for supporting the solid ring, and means for drawing the outer heads toward the inner heads to clamp the several rings to prevent lateral movement.

## FUEL CONSUMER.

An improvement in the art of consuming fuel in furnaces has been patented by Mr. E. H. Wade and Mr. J. L. Nicholson, Chicago, Ill. No. 851,330. The improvement consists in burning fuel in the lower part of a furnace while maintaining a partial supply of air through the bottom of the furnace, constricting the evolved gaseous body at a point between the burning fuel and the furnace outlet, and projecting into the constricted portion of the gaseous body and toward the burning fuel a number of converging streams of hot air, thereby establishing a barrier that is coextensive with the constricted portion of the gaseous body. The effect is claimed to be a considerable saving in fuel as well as an almost complete stoppage of the smoke nuisance.

### Locomotive Testing Plant.

Since November, 1906, the Locomotive Testing Plant of the Pennsylvania at Altoona, Pa., has been in continuous operation and a force of sixteen men have made, on an average, about three complete tests each week. Certain portions of the apparatus were temporarily installed at the Louisiana Purchase Exposition and the experience gained there has been embodied in the plant at Altoona. A building of steel and brick has been erected for housing the apparatus. The arrangement of the plant is shown in our illustration of the interior of the building. The floor of the laboratory is on the track level and is made in sections which can be removed by the traveling crane. The space between the removable floor is used for storing absorption brakes, supporting wheels and other parts when not in use. On the same level as the storage space and below the main floor is all the apparatus for water supply used in controlling the brakes.

The driving wheels of the locomotive under test stand upon supporting wheels with rims shaped to correspond with the head of a rail. The axles of these supporting wheels are extended and carry the absorption brakes. The turning of the driving wheels causes the supporting wheels to revolve. These wheels can be retarded to any desired extent. The work actually done by the locomotive consists in overcoming the frictional resistance of the supporting wheels and brakes, the resulting force exerted at the drawbar being measured by a traction dynamometer. The axles of the supporting wheels run in heavy pedestals secured to cast iron bed plates resting upon a concrete foundation. There are two bed plates running parallel with the track, and in order that the supporting wheels may be directly beneath the locomotive drivers, these bed plates are provided with T slots, so that the pedestals can be moved along parallel to the track and secured in any position to suit the particular engine under test. The only wheels of the locomotive which move during a test are the drivers. The wheels of the leading truck rest upon rails secured to I-beams which are supported upon the same bed plates which carry the pedestals. The wheels of the trailing truck rest upon supporting wheels which remain stationary during the test and are carried by pedestals secured to the longitudinal bed plates.

When preparing the plant to receive a locomotive, the pedestals are carefully bolted to the bed plates and so spaced that there will be a pair of supporting wheels directly beneath each pair of drivers of the locomotive. A

section of special rail is next bolted to the inside faces of the supporting wheels. This rail is a heavy I-beam, and to the top of this is fastened a grooved head in which the flanges of the drivers run. The tops of the supporting wheels are in line with the track entering the building, so that a locomotive can be backed in and the drivers will run on their flanges until in position directly over their supporting wheels. After a locomotive has been secured in place, and its drawbar attached to the dynamometer, these grooved rails upon which it moved in are removed, leaving the drivers resting upon the supporting wheels. The axle for each pair of supporting wheels carries upon each of its over-hung ends an Alden absorption brake. Each of these brakes consists of two smooth circular cast iron discs, keyed to the supporting wheel axle. On each side of each one of these discs is a thin, copper diaphragm, held at its periphery, and also at its inner edge to a housing which does not revolve and has its bearings upon the hubs of the

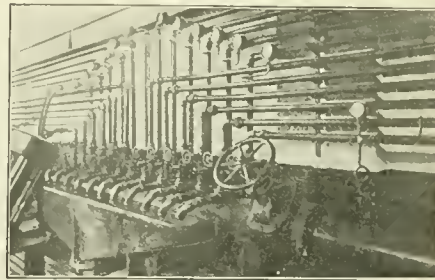

THE DRAINAGE SYSTEM.

circular revolving discs. The stationary housing is so designed that when it is filled with water under pressure the copper discs are forced against the revolving discs, thus creating friction. Provision is made for securing continuous and uniform lubrication of the surfaces of these revolving discs, and water is caused to flow through the housing in order to carry away the heat generated. The water thus performs two functions: First, in supplying pressure to cause the friction, and second, in carrying away the heat generated by the friction.

Each brake is connected with the source of water supply by a flexible hose. It is also connected with the discharge pipes by another flexible hose. The discharge pipes for all the brakes empty into an iron trough and each pipe is provided with a valve located adjacent to the valve in the supply pipe for the same brake. In placing the load upon the locomotive these valves are adjusted until the individual brakes each absorb their share of the work. After this preliminary adjustment has been secured the power absorbed by

all of the brakes may be increased or decreased by operating a large valve in the supply main.

In order to secure water at uniform pressure for use in the brakes an elevated tank has been placed near the testing plant building and a two-stage centrifugal pump, driven by a 75-h.p. electric motor, delivers the water at a constant pressure of 75 lbs. per square inch to the main header, from which branch the pipes leading to the individual brakes.

The locomotive under test is connected to the dynamometer by an adjustable drawbar, and the dynamometer housing is provided with means for raising and lowering the dynamometer proper so as to make this drawbar suit the various heights of locomotive drawbar attachments in the tailpiece.

The traction dynamometer which measures the drawbar pull of the locomotive is of the lever type. The lever system is constructed upon the Emery principle, in which flexible steel fulcrum plates take the place of knife edges used in ordinary scales.

Figure 10 shows the lever arrangement. The drawbar is shown on the right. The end of the drawbar is provided with a ball and socket joint to accommodate slight motion of the engine when running.

The oscillating motion of the lower ends of the levers is transformed into rotary motion of a vertical tube by means of steel belts wrapped about a drum on the bottom of this vertical tube and secured at their other end to the bottom of levers. The tube revolves in ball bearings and carries with it a steel rod, the upper end of which is securely fastened to the upper end of the tube, and the lower end fastened to the frame of the machine. When the belt drum and tube are rotated, the rod inside of the tube is in torsion. This torsion resistance forms part of the total resistance of the machine and is a constant for the same travel of the recording pen.

To the upper end of the tube are secured two radial arms whose ends are finished to a circle having its centre at the centre of the tube. By means of thin steel tapes the rotary motion of the circular end of the arm is translated into rectilinear motion of the carriage, which holds the recording pen.

Over the recording table an endless strip of paper 18 ins. wide is drawn, and upon it a continuous record of the test is made. The paper is driven by direct connection with one of the supporting wheels upon which the locomotive drivers rest. The speed reduction is so arranged that when the locomotive under test travels one mile on

the supporting wheels the paper moves 52.8 ins., giving a scale of 100 ft. to the inch upon the diagram. A datum pen marks a continuous straight line upon the paper.

The traction recording pen moves across the paper perpendicular to the datum line, its distance from the datum line being dependent upon the force

a jog in its line every time the integrator measures one square inch. The remaining electrically operated pens are used for recording such features of the test as taking indicator cards, etc. The whole plant has been carefully designed and is well equipped in every way, and much valuable information will be gained by the tests.

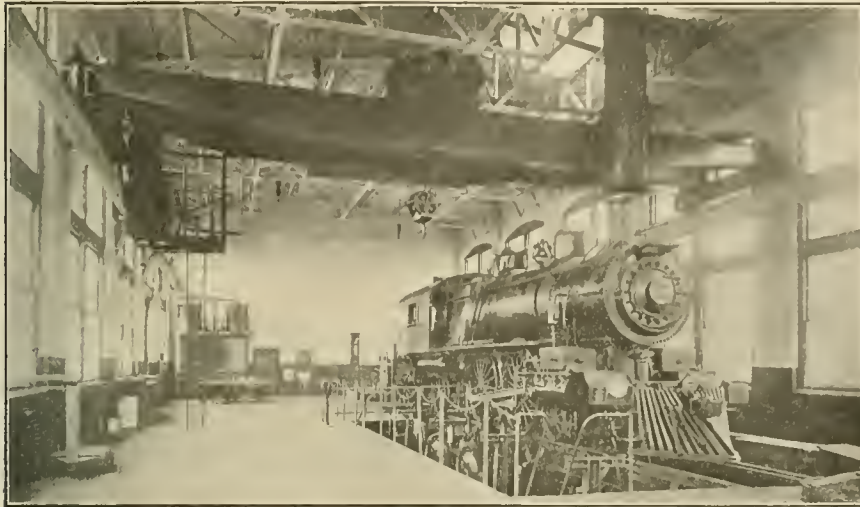

GENERAL VIEW OF PENNSYLVANIA RAILROAD TESTING PLANT.

transmitted by the drawbar from the locomotive. The maximum travel of this pen away from the datum line is eight inches. Two sets of springs are provided. With the heaviest set the eight inch movement of the traction pen corresponds to a load of 80,000 lbs. upon the drawbar, the maximum capacity of the dynamometer. With the other set of springs the eight inch motion of the traction pen corresponds to a pull of 40,000 lbs. upon the drawbar, and with all the flat springs removed, the eight inch motion corresponds to a 16,000 lb. load upon the drawbar. The total motion of the drawbar to give the eight inch movement to the recording mechanism is 1-25 of an inch. The multiplication of the recording and weighing mechanism is therefore 200 to 1. An integrator is provided and attached to the traction recording mechanism, so that the foot-pounds of work performed by the locomotive is automatically summed up. Five additional electrically operated pens are provided. They normally draw continuous straight lines. One of them is electrically connected with a clock, so that each second is indicated by a jog in the straight line which this pen normally draws. Another pen is electrically connected to a roller which is rotated by the recording paper, causing the pen to make a jog in the line for every thousand feet which the locomotive travels. Another pen is electrically connected to the integrator and makes

"Twentieth Century Developments" is the title of a very artistic catalogue issued by the McConway & Torley Company. It is, of course, concerned with railway passenger equipment and is well and fully illustrated by halftones and line cuts. There is a description of the Buhoup 3-stem couplers and the

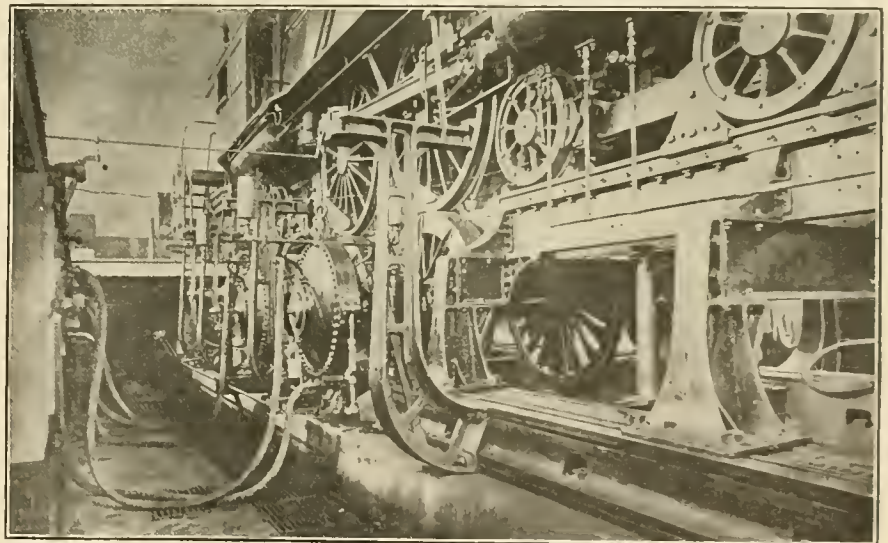

ENGINE IN POSITION FOR TEST AT THE ALTOONA PLANT.

Buhoup vestibules with sectional and plan illustrations. Steel passenger cars from the shops of four prominent makers show the style of the art as it is at present. The catalogue is well worthy of perusal and may be had by applying direct to the McConway & Torley Company, Pittsburgh, Pa.

### Machine Shop Reminiscences.

BILLY'S CAT.

When Billy came to his work in the machine shop he brought something for his cat every morning. The cat took it as a matter of course and was as ungrateful as the Prodigal Son. The cat slept all day and caroused all night. The sense of proprietorship seemed to satisfy Billy, and the sense of appeased appetite satisfied the cat. Other cats came and went, but Billy's cat became an institution. It held its place like the stationary engine or the wheel press.

Regularly every day at three minutes to twelve it came along the middle of the floor and looked at the clock and everybody knew that the whistle would soon blow and young and old got ready for the wild stampede for Clark's parlors. How the cat knew the appointed time was as much of a mystery as are the revolutions of the moons of Jupiter. Billy ascribed it to occult science. The cat was peculiarly dull in many ways. He had none of the hunting instincts of animals of the cat kind. Rats could run past his nose but he had no taste for them. What use was it as long as Billy furnished cooked meat? As for mice, the cat might truthfully be said to be good for mice in the sense that he never showed other than a kindly indifference to them. They could go their way and the cat went his.

One day we sat in the pit waiting for wheels. We were not as impatient

as the mother of Sisera who sat at the window and called: "Why tarry the wheels of his chariot?" It was one of those lulls that occur in the busiest machine shops, and is generally followed by a storm of haste to make up for lost time. Billy's cat lay in a covered recess at the end of the pit. He

was in a profound slumber. Billy looked at the cat and the cat awoke. Billy claimed that it was the co-relationship existing between himself and his cat that set the waves of thought radiating like ethereal disturbances caused by the flutter of a bird's wing, and these waves striking the cat in the maxillary process the cat thought it was near high noon and woke up. We sneered at his nonsense. Billy told us of a Scotsman who when he put on a dickey, a kind of imitation shirt front, he thought it was the Sabbath day. The association of ideas was nothing new, Billy claimed. Do we not imagine fire when we see smoke? Does the eagle

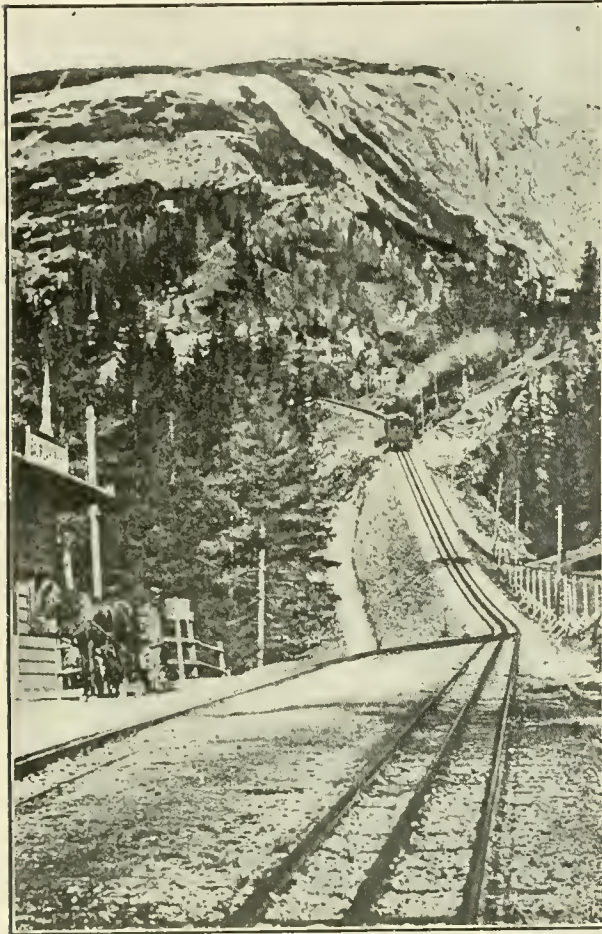

BAUMGARTNER STATION ON THE SCINEEBERG RAILWAY IN THE AUSTRIAN ALPS.  
(Courtesy of Travelers' Railway Guide.)

scream for nothing? No. There is prey somewhere within striking distance!

While Billy was advancing his occult theories and stretching his imagination, the cat was stretching its hind legs to an abnormal extent and then raising its back in the air it settled own to its natural posture and soberly walked along the floor casting its green eyes on the yellow faced clock. It was three minutes to eleven. The Dutchman who ran the stationary engine was in a day-dream. He was back among the vine-clad hills of the Rhine. He

saw the cat with one eye and he glanced at the clock dreamily with the other. *Mein Himmel! Was ist das?* It was outside and away down to the boiler room for him. He pulled a rope and the shrieking whistle rent the startled air.

The blacksmith's shop responded nobly to the false alarm. The machinists were not so easily led. A few of them had risen to the substantial dignity of carrying a second-hand Waterbury watch. The stampede to Clark's parlors was numerically weak, but what it lacked in numbers it made up in enthusiasm. The forenoon had slipped away pleasantly. Five hours was not so very much after all, but what—no soup, no lager on tap—eleven o'clock,—what was the matter with Gus? Somebody ought to flag him!

The scattered forces skulked back and the dumfounded Dutchman became a storm center. Had he brainstorms, or was he drunk? No—it was Billy's cat! The superintendent's whiskers bristled with indignation. Where was Billy's cat? Murphy, the foreman laborer, had the cat by the back of the neck. He was commanded to throw it over the fence. Murphy poised himself like a Greek discus thrower, and Billy's cat described a far sweeping parabolic curve, turning several end-for-end convolutions as it hurtled through the air. In the street there was the accumulated adjuncts of a new building in course of construction, and Billy's cat fell with a heavy splash into a wide plaster tank where the dissolving compounds were boiling and bubbling fiercer than the cauldron fed by the withered hands of Macbeth's witches. It looked as if it was the last of Billy's cat, but next day at the appointed hour out of the underland, out of the wonderland, shadow-like, there came a spectre, terrible as the ghost of Banquo, emaciated, dishevelled, beplastered, its eyes glowing like furnace fires, its tail trailing in the dust, a walking clay image, a hollow mockery, a mere shadow of Billy's cat! The dazed Dutchman looked twice at the

cat and three times at the clock. The superintendent was for once awed into silence. The cat shook its shaggy locks at him, and the eyes of a basilisk were as nothing to the eyes of Billy's cat as they fastened on the clock. In a minute the whistle blew, and in the wild rush for Clark's parlors the bewildered mechanics paused a moment to gaze on the solemn shadow of Billy's cat.

#### Quaint Origin of Things.

Those who take pleasure in unearthing the origin of sayings or of what may be almost called modern proverbs may be interested in a few quaint references to the past. Speaking of the origin of some popular sayings the *Brooklyn Eagle* says:

Of the various origins assigned to the phrase, "a baker's dozen," signifying thirteen, there is only one that can be regarded as authentic. In old times, in London, when a small retail dealer bought bread from the baker, for every dozen loaves purchased he was given one extra loaf as his profit, from which circumstance comes "a baker's dozen."

According to the historian Hume, William of Orange, afterward King of England, is responsible for the proverbial expression about "dying in the last ditch." When Holland was so beleaguered by her enemies that the salvation of the country from annihilation seemed impossible, the Duke of Buckingham remonstrated with William on his course and asked him to change it, alleging that the country was on the verge of ruin. "There is one means," the Prince answered, "by which I can be sure not to see my country's ruin: I will die in the last ditch."

In a volume of essays written by an English author, in 1815, there is the story of a boy who, by the offer of liberal compensation, was induced to turn a grindstone for a man who desired to sharpen his axe. The promised recompense was never made, and since then when one disguises his own selfish aims under an appearance of generosity or disinterestedness, it is remarked, "He has an axe to grind."

How many know the origin of "O.K."? About the year 1840, when Alvah Adams organized the Adams Express Company, a young man from the rural districts entered his office, asking for work. He was engaged, and began by sweeping the office and assisting in receiving express parcels. The boy kept his eyes and ears open, and took mental notes of the system employed by the shipping clerk, who placed upon the manager's desk each night a list of the packages marked "All correct."

The well known phrase, "Cut and run," originated in a peculiar custom of the ancient Egyptian embalmer. A low caste official was employed to make the first in-



cision in the corpse, a process viewed with much superstition and dislike by the people, who held all mutilations of the dead as being accursed. As soon as the incisor made his cut, he took to his heels, pursued by sticks, stones and curses. For his living the poor wretch "cut," and to save his life he had to "run."

The expression, "showing the white feather," as an evidence of cowardice is thus referred to in the *Washington Post*: An official of the Smithsonian Institution was speaking of the origin of some well-known phrases and pointed to a small mounted bird. This bird was a French gray on the back, drab breast, black wings and with a small but conspicuous white spot at the base of the tail. "That is a wheat-ear," the official said. "It is very common in Scotland, where it is known as the 'clacharan.' It is from this

fact, was very likely not a name proper originally any more than Mont Blanc. The natives may have spoken simply of "the white mountain" or "the headland," as we speak in London now of "the river."

#### Atlantic Coast Line 4-6-0.

The ten-wheel type of locomotive was introduced in 1846, when Septimus Norris and John Brandt built the "Chesapeake," which engine weighed in working order about 44,000 pounds. This 4-6-0 type of engine has since been extensively used, and while it has been superseded on some roads by the Pacific and Prairie types, it is still doing excellent work on many lines in both freight and passenger service. A modern example of a ten-wheel locomotive is being exhibited by the Baldwin Locomotive Works at the James-

The rocker shafts are placed ahead of the leading pair of driving wheel, and are connected to the link blocks by means of transmission bars. The springs for the leading drivers are overhung, while those for the main and trailing wheels are placed between the frame bars and connected by means of box equalizers. There are thus four pairs of driving springs, as the trailing wheels have a pair on each side of them. All the wheels are flanged, and the drivers are equally spaced at 81 ins. apart. The frames have single front rails, and are 4 ins. wide throughout.

The boiler has a straight top, with a wide firebox. The mud ring is sloped toward the front to give sufficient depth at the throat. The firebox is provided with a brick arch, supported on water tubes. The throat sheet is sloped to clear the driving wheels, while the back head

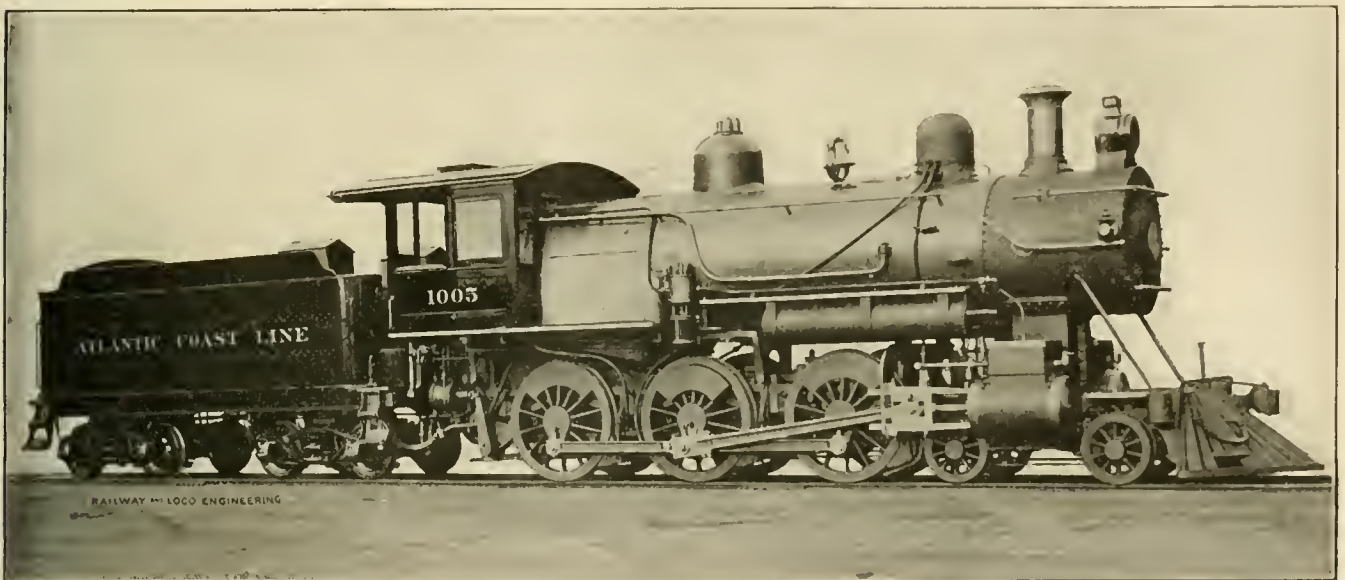

MODERN TEN-WHEEL ENGINE FOR THE ATLANTIC COAST LINE.

R. E. Smith, Gen'l Supt. of Motive Power.

Baldwin Locomotive Works, Builders.

bird that we get the expression 'showing the white feather.' You will notice the location of the only white feathers on its body—they can be seen only when the bird is flying away from you."

Travelers from this country to the British Isles who pass the coast of Cornwall generally get a glimpse of the rocky headland called the Lizard Point. The *London Chronicle* says: The name of the Lizard has naturally caused many to see a lizard-like appearance in the promontory's shape, or in the variegated aspect of its cliffs as viewed from the sea, and to suppose that some fanciful person of bygone days named it accordingly; but says a London writer, it is probable that the name is really Celtic and means only projecting headland. In that case the first syllable is that which appears also in Liskeard and Lismore, and the second is to be found likewise in Ardnamurchan, Ardmore and Ardrossan. "Lizard," in

town Exposition. This engine has been built for the Atlantic Coast Line Railway, on which road it will be put in service after the close of the Exposition. The design is representative of recent practice, while utilizing features which have proved satisfactory in service.

The cylinders are 20 x 20 ins., single-expansion, equipped with balanced slide valves. An interesting feature is the guide yoke, which is parted in the center, the two sections being securely bolted together. With this arrangement it is unnecessary to take down the entire yoke when making repairs on only one side. The driving wheels are 63 ins. in diameter, and carry a weight of 113,700 lbs. These dimensions, with the fact that the steam pressure carried is 185 lbs., give a calculated tractive effort of about 26,000 lbs. The factor of adhesion is 4.3.

The ordinary shifting link motion is used, with eccentrics on the second axle.

is straight. The diameter of the boiler at the smoke-box end is 66 ins., and a total of 2,679 sq. ft. of heating surface is provided. The firebox, which is 96¼ ins. long by 66 ins. wide, and 63 ins. deep at the front and 51½ ins. at the back, gives 151 sq. ft. of heating surface. There are 334 tubes, made of steel, No. 11 wire gauge in thickness, 2 ins. diameter and 14 ft. 5 ins. long, and these give 2,506 sq. ft. of heating surface. The fire brick tubes add 22 sq. ft. of heating surface, thus making the total quoted above. The grate area is 44.1 sq. ft., which gives a ratio of grate area to total heating surface as 1 is to 60.

The tender frame is made of steel channels, and the whole is carried on arch-bar trucks. The journals are 5 by 9 ins., and the wheels are 33 ins. in diameter. The tender is provided with a U-shaped tank, having a capacity of 6,000 U. S. gallons of water and 9 tons

of coal. The whole engine presents a neat and trim appearance, and looks, as Kipling would probably say, like a "clean limbed" machine fully able to do the work expected of it. The principal dimensions of the locomotive and tender are as follows:

Boiler—Thickness of sheets, 11/16 in.; fuel, soft coal; staying, radial.  
 Fire Box—Material, steel; thickness of sheets, sides, 3/8 in.; thickness of sheets, back, 3/8 in.; thickness of sheets, crown, 3/8 in.; thickness of sheets, tube, 1/2 in.  
 Water Space—Front, 4 ins.; sides, 3 ins.; back, 3 ins.  
 Driving Wheels—Journals, 8 1/2 x 10 1/2 ins.  
 Engine Truck Wheels—Diameter, front, 31 3/8 ins.; journals, 5 x 10 ins.  
 Wheel Base—Driving, 13 ft. 6 ins.; total engine, 24 ft. 4 ins.; total engine and tender, 54 ft. 6 1/2 ins.  
 Weight—On driving wheels, 113,700 lbs.; on truck, front, 37,900 lbs.; total engine, 151,600 lbs.; total engine and tender, about 270,000 lbs.

#### Cowlairs Incline at Glasgow.

The idea of a railway between the official and commercial capitals of Scotland early presented attractions to the practical minds of the natives of that country. Besides adopting horse railways or tramroads very early in the last century, a large scheme was got up in 1825 for a railway from Leith Docks to the Broomielaw of Glasgow. The route chosen by Midcaldor and Holytown, however, was too steep, reaching 800 feet

The act authorized the raising of £1,200,000 for a main line 46 miles in length; the branch, however, was never made. By cutting 60 ft. deep through the ridge of hills at Croy, the summit of the line was only 226 ft. above sea, but its excellent gradients were not obtained without a great deal of constructional work. At Callender is a tunnel 830 yds. in length, on an easy curve, but the tunnel forming about half of the 1 1/4-mile incline from Cowlairs down to Glasgow is better known to the public. It is divided by two short breaks of about 100 yards each into three sections. These and the Callender tunnel were originally as rather terrifying places, whitewashed and lighted with gas lamps placed 80 ft. apart alternately on each side of the excavation. This Cowlairs incline forms the only departure from the generally excellent levels of the E. and G. Ry. Being thought too steep for locomotive traction, a pair of beam engines, built by Kerr Neilson & Co., of Glasgow, were placed at the head of the incline, of 80 horsepower each, but capable of working up to 100 H. P., and of being applied singly or together. They turned a large drum, round which an endless rope went down one line, round a horizontal grooved

tons and lasting some 15 months, more or less, are used, but the original ones were of hemp. They pass over sheaves or on grooved pulleys between the rails to keep them from rubbing on the sleepers or ballast, and to preserve the proper course. Mr. John Miller, one of the most eminent of Scottish engineers, laid out the line. The formal opening of the E. and G. Ry. took place on February 18, 1842, no portion of the line having been opened previously. Three trains each of 10 first-class carriages were successively drawn up the bank to Cowlairs and sent on as one huge procession, with 3 engines, soon after 9:30 a. m. A pilot engine ran nearly a mile in advance. So much time was lost watering at Falkirk and in other ways that Edinburgh was not reached till 12:15. Such anxiety prevailed there that an engine had been sent out 2 miles to look for the train. A similar train of 27 coaches left Edinburgh at 1:10 p. m. and reached Cowlairs at 3:47, a second special following half an hour later. Dinner was provided in the station at Glasgow, which was gaily decorated with white and crimson cloth. Over the head of Mr. John Leadbetter, chairman of the board of directors, who presided, was a representation of a locomotive engine. The Lord Provost of Edinburgh drank "Success to Edinburgh and Glasgow Railway Company." On the return one of the trains was delayed over two hours by the breaking of the rope on the incline, but fortunately the brake power proved sufficient to prevent the train running back. One strand of rope appeared to be cut.

The directors of the E. and G. Ry. seem to have been an enlightened and wideawake body, for they readily allowed experiments in electric traction to be carried out on their railway so early as September, 1842. These were made by Mr. Robert Davidson, of Aberdeen, and proved that a 4-wheeled truck could be moved by the current generated by 6 powerful batteries. There were three strips of soft iron fastened transversely on each of 2 wooden cylinders surrounding the axles. Two large electromagnets were placed on the carriage, on each side of both axles, making eight magnets in all. The current passed from the batteries formed of zinc and iron plates in dilute sulphuric acid, to these magnets, whence by a simple arrangement it was led through a wire to the iron strips in rotation, the magnets thus pulling the axles round. A speed of only about 4 miles an hour was attained, the truck weighing about 6 tons with all the apparatus. The extent and brilliancy of the repeated electric flashes perhaps frightened the directors, anyhow it is plain that current produced by batteries could not suffice for railway traction on the ordinary scale. The company, however, paid for fitting up the vehicle and



PASSENGER TRAIN BEING HELPED UP THE COWLAIRS INCLINE.

above the sea at one point, and another surveyed later on, for going by Bathgate to join the Garnkirk and Glasgow Railway, would have passed over a height of 500 feet. Experience showed that such attitudes would not do for comparatively short lines, a new company was formed in 1835 which succeeded in obtaining in 1838 an act for "The Edinburgh and Glasgow Railway," with a branch to Falkirk.

wheel, and back up the other. Except for a short period these fine old beam engines have been at work ever since 1842. The supports of the beams and overhead gear are cast iron columns of the Grecian type, then considered so peculiarly appropriate for the framing of marine and stationary engines. The gradient of the incline is about 1 in 42 or 1 in 43. Wire ropes now weighing 24

deserve credit for having at least demonstrated that a railway truck could be moved by electricity. They applied the electric telegraph to the working of Cowlairs incline from the beginning, the dial of the instrument having two pointers for giving eight signals. An alarm bell to call attention was fixed on the top.

The Cowlairs shops were established with the line, engines being built there from time to time, but the company always largely relied upon outside builders. Perhaps the most remarkable engines built there were the two six coupled well-tanks Hercules and Samson, constructed in 1843 and 1844 for working the incline. The winding engines were not strong enough at first, their boilers steamed badly and huge hemp ropes proved unsatisfactory. Mr. Paton therefore designed two locomotives in substitution for them. These had cylinders  $15\frac{1}{2}$  by 25, very steeply inclined, wheels 4 ft.  $3\frac{1}{2}$  ins. in diameter, 136 two-inch tubes giving 748 sq. ft. of heating surface, which with 60 ft. more in the firebox made 808 sq. ft. The grate area was  $16\frac{1}{2}$  sq. ft. The tank held only 200 gallons, it was under the front of the engine and had means of letting a small jet of water run upon the rails to clean them. The first of these engines was tried on January 31, 1844, and as soon as the second was ready the rope working was given up. They weighed 22 tons empty and  $26\frac{1}{2}$  tons full. Two similar engines of greater power were built later on at Newcastle and named "Millar" and "Hawthorne." The stationary engines were retained in the hope that they might do for the atmospheric system, in case that should prove suitable for incline working. As it did not, and the vibration of the locomotives threatened the stability of a canal just over the tunnel, the latter were given up in 1847 and the rope resumed. The cylinders of the winding engines were enlarged from 28 ins. to 36, the boilers reset, the spur-gearing simplified, and from that day to this the curious old beam engines have done admirably well. It was found that the wire rope of 4 $\frac{1}{2}$  ins. in circumference, but weighing 19 tons, required less power to work it than the 7-in. hemp rope of only 11 tons, whilst its durability and safety were much greater. At present neither rope nor locomotive is employed for descending trains, which are piloted down only by the incline vans, but both are used coming up. A short length of rope termed the "messenger" connects the main rope and the engine, a special attachment on the latter, preventing the rope from pressing against the leading axle. The locomotives go down light, tender first, the incline vans coming up at the tail of the train as additional security in case of a breakaway. Our illustration shows a train coming up with the rope attached. At least one of England

& Co.'s light "single" tanks No. 58, "Little Scotland," was used between 1850 and 1860 on the E. and G. Ry., and was said to do very well on the express.

The Edinburgh and Glasgow Railway Company was not a great success financially during the 24 years it was open as an independent concern, and in 1865 it became amalgamated with the North British Railway. A letter from Mr. W. P. Reid, locomotive superintendent of the

tendents of machinery—men who, while at present are at the head of an important branch of a department, will in future become the head of the entire department. In other words, they are at present attending a school from which they will eventually graduate, a large number of them, if not all, with honors of which anyone could be proud.

"In your deliberations here, many important questions will come before you



DOUBLE HEADER AND CABLE HELP ON COWLAIRS INCLINE.

North British Railway, published in our General Correspondence columns, shows that the Cowlairs incline is still worked by cable.

#### General Foremen's Association.

The third annual convention of the International Railway General Foremen's Association, held at the Lexington Hotel, Chicago, Ill., May 14 to 17, 1907, was called to order by President G. A. Swan, Jr., at 10 o'clock. The Rev. J. A. Rondthaler, of the Normal Park Presbyterian Church, invoked the divine blessing, after which the regular business followed. Mr. Wilson E. Symons, who was called on to address the meeting, spoke in part as follows:

"It is with a sense of the deepest gratitude and highest appreciation that I responded to your complimentary request to be present, and the additional compliment in being called upon for a few remarks.

"In looking over this gathering here this morning, I feel that while I am looking in the faces of general foremen, that I am also looking into the faces of some future master mechanics and superin-

and be analyzed in a manner that will not only be useful to the different members by an exchange of views, one with the other, but all deductions reached and the conclusions come to will be of inestimable value to your superiors. Quite true it is that you do not decide all matters of importance in connection with the design of locomotives and cars, but it is also true that the men who do decide such questions secure a great deal of their most valuable information from you who are in daily touch with the practical operation of locomotives and cars.

"Of recent years the advancement in the construction of locomotives has been such that it has been almost impossible to keep pace with the improvements in that direction. The same is true with cars and shops. It is not many years ago that a locomotive with thirty thousand pounds tractive power was considered a large engine. To-day we have locomotives of forty, fifty, fifty-five, fifty-eight and sixty thousand pounds tractive power, and in connection with the Articulated Mallet Compound engines we have 71,500 lbs. tractive power, while the Erie has recently ordered for service on their lines engines of this type with 98,000 lbs.

tractive power. These locomotives are equivalent to five of the engines that are considered a modern engine a few years ago, when the 999 was in the zenith of her fame. We have not only the evolution of the engine of to-day, but we have future possibilities that must fall upon the men upon whom it is incumbent to not only solve the present questions in connection with the operation of these engines and cars, but also the men who are to provide the ways and means for meeting future possibilities and requirements.

"The question of the use of compound engines is a very important one, and in so far as improvements have been made, it is proper, I think, to give due credit to the general foremen.

"Among the many questions coming up for attention, there is the question of superheating, which is now very prominent before the railway engineering world. This is one of the live questions which you, gentlemen, can, by exchange of views, give to each other information to carry home and use in connection with your official duties on your road that you could not secure in months, or possibly a lifetime if you were not here at this meeting.

"It is true that this gathering here this morning is not as large as we sometimes see, but when I look back and observe the growth of other associations, it is hard to predict what the outcome of this association might be. The Master Mechanics of America were organized in Garrett's Hall, Cleveland, Sept. 30th, 1868. There were forty-one members present at the time of their original meeting. Now the membership is numbered at about 800. There were at that time 42,000 miles of railroad. The Master Car Builders' Association was organized by a little handful of men at Springfield, Mass., in 1867, at which time there were 30,000 miles of road, 268 locomotives, 16,000 freight cars and 220 passenger cars, while to-day there are about 220,000 miles of main line of track and over 300,000 miles of double track and important sidings. The estimated valuation is placed at \$16,000,000,000. There are now approximately 50,000 locomotives, 40,000 passenger cars. The roads employ over 1,500,000 men, furnishing support for approximately 9,000,000 souls, with a payroll of over \$38,000,000 a year. This has grown from 23 miles of road in 1830 to 10,000 miles in 1850, 74,000 miles in 1875 and 200,000 miles in 1900. There are over 5,000 general officials, of subordinates or middle officers the same number, making a total of about 11,000 officers. There are 50,000 clerks, about 112,000 enginemen and 150,000 trainmen; about 48,000 machinists, 56,000 carpenters, 176,000 other shopmen, and of miscellaneous employees and laborers, 175,000, making a total of 783,000 employees, with

whom you come in contact, either directly or indirectly, the majority of the number of whom are subordinate to you, gentlemen. It is, therefore, very plain to see what influence you exert in other directions than from a strictly engineering or technical standpoint.

"A few years ago, organizations similar to yours were started under less auspicious circumstances than yours. I refer to the Traveling Engineers Association. Their first meeting was held in Chicago on the 12th of November, 1892. The next meeting was held in the office of *Locomotive Engineering*, 256 Broadway, New York, January 9th, 1893, at which time there were eighteen members present, with some represented by letter. This association received the unstinted support of Mr. Angus Sinclair and Mr. John A. Hill, editors and publishers of *Locomotive Engineering*, a paper interested in such questions as you have been working on during your entire official career. To the columns of this paper and the efforts of the editors is doubtless due a great deal of the success of this organization. It is to-day an organization of about six hundred members, and is a recognized authority on matters in connection with the operation of locomotives. A comparison between the two associations, with the possibility of the growth of yours, is of the most encouraging nature.

"In regard to the mechanical questions other than these mentioned. There are at present a number of very important ones that are being studied by the railway officials and mechanics. One is the question of high steam pressure in locomotive boilers with which you are all doubtless very familiar. Another is the compounding of locomotives, the different classes of compounds, the question of operation or installation of electric equipment as a substitute for steam, together with the use of motor cars for suburban service, in so far as your official duties have brought you in connection with them. These subjects are very important ones for you to consider. As I previously said, and will again say in conclusion, the information you gather at these annual meetings by telling your experience in connection with these different subjects will be of very great value to yourselves, your superior officers and the railway engineering world."

#### PRESIDENT'S ADDRESS.

Mr. C. A. Swan, the retiring president of the association, delivered his address. He said: "Ladies, Gentlemen and Members of the International General Foremen's Association. It gives me great pleasure to welcome you to this, our third annual convention.

"The past year has given us much to be thankful for, and has yielded a good crop of results. The membership has been largely increased through the in-

terest of members of the association, some speaking of it in a quiet way to others and thus gaining their interest, and by a great deal of correspondence on the part of the officers. A decided general interest has been awakened among the officials of the various railroads, whose foremen have been with us for the past two years, and have proved by the betterment of shop conditions that after all there is something more to it than mere talk and another place to go on company's time. The foremen have the privilege of bringing up puzzling questions for general discussion, thus bringing out a good many sides and thoughts on the subject. I have before me, and on file, numbers of letters from officials requesting the date of the convention so that they can arrange to let their foremen be with us; other letters asking if we will allow them to come, and still others saying they will be glad to know all we can let them know of what we are accomplishing. I think you will be surprised when you listen to the report of the secretary and treasurer, which will be read later on during the proceedings, at the progress made and enthusiasm shown. This year's topics show an increasing desire for help along difficult lines, and an awakening to the fact that general discussion of troubling questions will help smooth out the rough places and give us a clear view of the point at issue.

"I have traveled during the last year on a number of railroads throughout the United States and Canada. I have not been to Mexico, but am going later on. It has been my aim at every point at which I stopped to visit the foremen after I was through with my business, and as a general thing my business was not of long duration. My business brings me in touch with the presidents of the railroads, and I am handed down the line until I finally wind up with the round-house foreman, where my trouble ends. I have talked about the association to each man that I met, and it seems that the meaning of our association is misconstrued by a great many of our men—"The International Railway General Foremen's Association." In talking to the different foremen they will ask me 'Am I eligible to join?' I say, 'Certainly you are.' I talked this matter over with Mr. Cook after I returned from a ten weeks' trip in the East, and I requested him to make a public announcement through the papers what the object of our association is. It was my intention, in getting out these invitations, to have the object of the association printed on it, but in submitting it to expert printers they advised me it would spoil the effect of it.

"Now, I would request that each and every one of you try to clear up the matter as to who are eligible for members. True, there are a lot of publications re-

garding this matter, but some of the men never see them. The topics for discussion, gentlemen, are watched with a great deal of interest by superintendents of machinery. Several of them have written to me and have asked to have mailed to them a copy of the topics we have up for discussion, which I have done. We have two topics in which there is a great deal of interest taken—one is 'The Individual Effort System' and the other is 'Piece Work.'

"I do not think that there was a man in the western country that opposed piece work any stronger than I did. In fact, when Mr. Barton wrote to me and told me that he was going to put that in as one of the topics for discussion, I told him he could not do so. I think we traded about eight letters, and I finally told him that if he put that topic in, he did so over my head, which he did. A short time after that I went through the country and, as a great many of us go to church and are converted, I was finally converted.

"Piece work, properly carried out, was found to be just and right to every man who handled it, and there is no place in the United States where this work is handled so successfully as it is on the Erie Railroad by Mr. Cozad, and there is no man held in higher esteem than Mr. Cozad is. I know this because I went through the shops, and in talking to the men, and the men did not know that I knew Mr. Cozad, I found that there was the best of feeling existing between him and the men. Piece work is worked successfully on the Erie, and they can tell you, even to the smallest detail, what the expense is to perform that operation.

"Mr. Cozad is chairman of the committee in whose charge the topic 'Piece Work' was assigned. He was very much discouraged at first, and did not think he could get out a paper. I wrote him several letters, and am pleased to say we have a very valuable paper on this subject, beautifully written. Before closing I want to thank you for the support received from the members, and the courtesies and help from the officials and all for the general interest shown in the betterment of the service."

#### Most Awfully Quite Better.

"I'd like to know," demanded the irate passenger, "why you don't give better service on this line? Here I am forty minutes late this morning!"

"We are giving better service," retorted the station-master. "Last month this train was always forty-five minutes late."

"Now, look here," said the I. P., "all the cars are full; it is disgusting the way this railway is run. Please tell the company from me that if this continues I will withdraw my patronage from them and buy an automobile."

#### Problems in Railway Signaling.

Not long ago the New England Railroad Club had the pleasure of listening to a paper on some of the new and a few of the old problems in railway signaling. The paper was read by Mr. W. H. Elliott of the engineering department of the New York Central. In speaking of the fact that the number of accidents which have recently occurred has focused public attention on railroad signaling systems, he said that there are few who would deny that a block system, however weak, would not be of some advantage in reducing the number of accidents. Will the Interstate Commerce Commission, in prescribing rules and regulations, take cognizance of the many unsolved problems in signaling and say

single lines many and fast trains are run. There are many block systems, more or less complete, which may be used for single or double track roads. On many points signal engineers do not agree, and definite action has not been taken by the Signal Association. Some of these questions may be here summarized.

Shall a distinctive color be used for the clear night signal indication or shall the white light be continued in use? The Signal Association has recommended that a distinctive color be so used and several large roads now use green for the night signal "clear" indication, and yellow for the caution night signal indication.

Are continuous track circuits necessary for a sure-working block system? Judging from the apparently successful



RIVER AND RAIL AND A WELL MADE ROAD ON THE PENNSYLVANIA.

what should be considered good and what bad practice?

The Board of Trade in England has prescribed an elaborate set of rules and regulations regarding signaling which roads in that country are compelled to live up to, and new roads may not begin operation until the prescribed signal system has been installed and is in working order. The staff system is required on single-track roads. While this affords almost complete protection against head-on collisions, such delay is caused in running fast non-stop trains that few can be run under this system. Double track lines are, therefore, more often the rule than the exception.

In this country only a small part of the total mileage is double track, and on

working of thousands of miles of roads which are not equipped with track circuit it would appear that a track circuit is not a necessary safeguard. Yet the record on roads protected by the manually operated block signals show many accidents have occurred which would have been prevented if the working of the signals had been controlled by a track circuit. With the telegraph block system accidents have happened which in many cases would have been prevented if a track circuit had been used to control the working of the manually operated signal.

With the wide heads of heavy rails now in use is it not advisable to take off the detector bars and depend on electric locks controlled by track circuit to hold

the interlocking levers and prevent a switch being thrown under a train? This is a new problem and has arisen by reason of the fact that with 90 and 100 lb. rails the tread of the wheels does not often project over the outside of the rail sufficiently to catch the detector bar. The size of the rails will not be made smaller and it is necessary that some more efficient means than the detector bar be provided. The track circuit, controlling an electric lock on the switch, seems to provide the required protection and to be surer than the detector bar.

Do automatic signals give sufficient protection to require their installation as necessary for the safe movement of trains on a single track road? In the United States the telegraph block system is the one most generally employed on single track lines. Where greater protection is required the automatic system is usually put in. When installed with signals for opposing movements; staggered, and placed on each side of the main line switches, the automatic system

proach lock, by which the route through an interlocking plant is locked when the signal is cleared, and cannot be changed until the train has passed the signal, is most generally shown in the investigations that are made into the causes of derailments or accidents resulting from the home signal being improperly run by. The possibility of the route being changed, either through carelessness, poor judgment or undue excitement on the part of the signalmen, will always exist unless a lock is used to prevent a change being made. As generally applied, the lock takes effect when the home signal is cleared, provided an approaching train is within a certain distance of the distant signal. If a train is not approaching, the signal may be cleared and returned to the stop position at will, as it is the presence of the train that drops the lock and holds the route. The lock becomes effective only when the lever has been reversed, and while the lever may be returned to the normal position at any time, the latch is held by the lock

in addition to the normal control provided by the lever of the interlocking machine.

Has the automatic stop been so perfected that it may be considered sufficiently reliable to warrant its use, and if used would the number of accidents have been materially reduced? It is probable that as many patents have been issued for automatic stop devices as for any other apparatus in use on a railroad. While the stop is successfully used on elevated and protected subway roads, it has not been sufficiently developed to warrant its application to a steam surface railroad.

Is it advisable to use an overlap and insure a clear section of track ahead of a home signal, equal in length to the braking distance, in which an engineman may be given a chance to stop after passing a home signal and before coming into collision with a train that may be on the track ahead? Without an overlap an engineman must act on the indication of the distant signal to insure against colliding with another train. With an overlap, it is possible for the engineman to stop his train before hitting another train, although the brakes were applied only when the train passed the home signal. The engineman is therefore given two chances in which to bring the train safely to a stop.

Of what length should the blocks be made when a road is signaled for a maximum traffic? This is an important question, in view of the necessity of operating trains safely in the crowded terminals of our large cities. A train may be safely run at a given speed, other conditions permitting, when the engineman is given warning at a point far enough away to enable him to bring the train to a halt before passing the stopping point. The distant signal is the warning point and the home signal the stopping point. Unless there are to be two distant signals for each home signal, a practice that is not to be recommended, the space between the distant signal and the home signal is therefore the shortest length of block that may safely be used. The space to be provided between the distant and the home signal is a matter of the speed of the train, the braking power and the grade of the track; and when the signals are arranged to suit the conditions existing at a given point, the blocks will be as short as it is safe to make them, and the maximum traffic will be provided for.

In arranging signals to indicate the speeds that may be safely run, are the principles of route signaling, as understood at the present time, to be ignored? Speed signaling, as recommended by a committee of the Signal Association, calls for three arms to be provided on all interlocking home signal poles, of which the upper arm will govern for train



IN THE DAYS OF LONG AGO—NEW YORK "L" ENGINES AS THEY CAME FROM THE PITTSBURGH LOCOMOTIVE WORKS.

gives a large degree of protection. "In no instance, in my experience," said Mr. Elliott, "have distant signals for each home signal been provided with this system, but to do without distant signals is to dispense with an important part of the signal system."

Where automatic block signals are used, is it necessary for a man to go back and flag following trains? Where the blocks are long and trains infrequent, the necessity for flagging is more apparent, and men can be more fully depended upon to obey the rule. If there are places where the flagging rule cannot be strictly observed, is it not time to recognize this condition and so change the rule that it will not be held over the flagman's head to convict him when there is an accident, and to be overlooked as long as trains are running satisfactorily?

Is the use of approach locking warranted, with its complications, delays to traffic and increased cost of installation and maintenance? The need of an ap-

proach lock, by which the route through an interlocking plant is locked when the signal is cleared, and cannot be changed until the train has passed the signal, is most generally shown in the investigations that are made into the causes of derailments or accidents resulting from the home signal being improperly run by. The possibility of the route being changed, either through carelessness, poor judgment or undue excitement on the part of the signalmen, will always exist unless a lock is used to prevent a change being made. As generally applied, the lock takes effect when the home signal is cleared, provided an approaching train is within a certain distance of the distant signal. If a train is not approaching, the signal may be cleared and returned to the stop position at will, as it is the presence of the train that drops the lock and holds the route. The lock becomes effective only when the lever has been reversed, and while the lever may be returned to the normal position at any time, the latch is held by the lock

and the route cannot be changed until the head end of the train has passed the home signal and arrived at the point where the route should be released. What interlocking signal protection should be provided for a drawbridge to insure that all parts are in proper position, and is it safe for trains to pass over the bridge without stopping? It has usually been considered that sufficient protection was provided when the bridge itself was locked in place before allowing the signal to be cleared, but the several derailments that have occurred have shown that it is as necessary to lock the lift rails in place as it is the points of a facing switch. Safe working can be secured only by providing complete interlocking protection and the elimination of the human element as far as possible. Complete interlocking protection requires that the bridge must be in place and the lift rails locked in position before the signals can be cleared. Also, that the signals must be automatically controlled

movements to be made on an unlimited speed route, the second arm to the limited speed route and the third and lowest arm to the diverging, slow-speed and all other routes.

#### Shaw Cranes for Panama.

Our illustration shows one of a lot of eight cranes now under construction by the Shaw Electric Crane Co., of Muskegon, Mich., for the Panama Railroad Co. They are for use in handling miscellaneous freight at the Laboca wharf, which is the Pacific terminus of the railroad. The cranes were designed to meet the peculiar conditions existing at the wharf, among which may be mentioned a tidal variation of about 20 ft.

The boom, which is 80 ft. in length, is shown in its working position in Fig. 1. It is standing at an angle a little over 30 degs. from horizontal. It is necessary that the outer end should stand at a sufficient height to enable the crane to carry loads over the decks of the largest vessels at high tide, while the other end must be low enough to project inside of the warehouse door. The boom may be raised to the position shown in Fig. 2, carrying the outer end clear of all parts of vessels and withdrawing the inner end from the warehouse. When in this position, vessels may be docked and the cranes placed opposite the various hatchways in proper position for loading or discharging cargoes.

The main frame or tower is of steel and stands 62 ft. above the track. There is a clear opening through it 10 ft. wide, in which the boom is suspended and through which the loads are carried. The base is so constructed that the crane can travel over freight piled to a height of 6 ft. between the tracks. Goods may be trucked directly from under the crane to the warehouse. The space between the front of warehouse and edge of wharf was sufficient for a track of only 11 ft. gauge. This, together with the necessary height and reach, made the question of stability a serious one. Although the weight of frame and machinery has been so disposed that the crane is stable with a load 25 per cent above its normal capacity in the extreme position, clamps have been provided which are always in engagement with the rear rail, to prevent the crane from tipping if a load should become fouled on a hatchway or other part of the vessel.

The crane is mounted on six wheels, four under the front and two under the rear. Anticipating the possibility of uneven settling of the wooden wharf, the wheels are carried in equalizers, so arranged as to compensate for any probable irregularities of track without straining the structure. The machinery for the various movements is placed in the base of the tower, adding to the stability of

the crane, and giving easy access for inspection. For convenience in shipping and erecting, each set of machinery was mounted upon a separate frame, which was easily handled and put in place.

The crane has a regular working capacity of four tons and a reach of 40 ft. from the center line between rails to the extreme outer position of load. The total height of hoist is 70 ft. and the speed, hoisting with full load, is 150 ft. per minute. The load can also be racked out and up at a speed of 150 ft. per minute. The other two movements, travel and boom hoist, are relatively slow, being required only in setting the crane in position for service.

The hoist is operated by a 65 H. P.

#### Anti-Collision Ideas.

There is one thing which has always appealed to the inventor, and that, strangely enough, is the form of railroad accident which results when two trains come together on the same track. In early days some person proposed having a balloon-shaped bag carried on the buffer beam of a locomotive, with the probable intention of breaking the force of impact if two engines came together. Other variations of the same idea have been put forward from time to time. Cotton bales in front of an engine were thought by some people to be a great help, and we remember a patent not long ago in this country where a col-



FIG. 1. WORKING POSITION OF TRAVELING CRANE.

motor, the rack motion by a 40 H. P. and the travel and boom hoist by two 24 H. P. and 8 H. P. motors respectively. Automatic switches are provided to prevent overtravel in hoisting and racking out, also an overload switch for the hoist machinery. All the crane movements are under the control of one operator, whose cab is so placed as to give him the best view of his work. The crane weighs nearly 50 tons, and with the boom in the raised position, as shown in Fig 2, which is illustrated on the next page. The whole crane is a unique piece of mechanism and it stands 90 ft. above the wharf. The motors and controllers, as well as all the structural work and machinery are the product of the Shaw Electric Co.'s plant at Muskegon.

lapsible frame carried on a truck was pushed along by a locomotive as if looking for a collision.

It has also been proposed that a coach in the middle of a train should be made of such material as would readily break up when an accident happened, and so relieve the strain on the other cars. A further curious idea in connection with the easily destroyed car was that it should carry a surgeon and medical supplies and appliances. As this car was intended to be the first one put out of business if anything happened, the necessity of carrying this remedial equipment for the rest of the train is not quite apparent.

The easily breakable car in a train has, however, been put into practice,

but the surgeon and the medical supplies are not carried. It can be seen when one gets a sight of an old 40,000 lb. capacity box car in a train of modern, high-side steel, 100,000 lb. capacity gondolas loaded to the full with coal or ore.

Another anti-collision device was that a locomotive should be coupled to a train by a steel cable about a mile



FIG. 2. BOOM PULLED UP AND IN.

long and thus, in the event of accident, only the engines and their crews would be in immediate danger. This was a beautiful idea, because no long rock cuts would be permitted on curves, as the rough sides would be liable to chafe or cut the cable, and the absence of these cuts or tunnels would add to the passenger's enjoyment of the scenery which would consequently be spread out before him.

#### The Value of Literature.

Sallust, the Roman historian, had an abiding reverence for literature. To him life without books was not worth living. *"Vita sine litteris mors est,"*—"Life without literature is death."—was one of the axioms that he taught the Roman youth. That there are thousands who live and move and have their undeveloped being without books is true, but their existence cannot be called life in the full sense. Without literature the mind is stunted and shrivelled and choked by the weeds of ignorance. In our day books are an essential adjunct to the proper training of youth in any kind of occupation, and in none more so than in the vast and ever widening field of the manipulation of the mechanical appliances used on railways. Railway men

who do not constantly keep abreast of the full tide of the records of invention and application of new means and methods are not to be classed with the men who are constantly in touch with the literature of the time. RAILWAY AND LOCOMOTIVE ENGINEERING is in the forefront of the railroad literature of our time and is a library in itself. Our readers are also constantly advised of the books that are worthy of their attention. Among the aids which we can recommend to our readers are the following books:

"Machine Shop Arithmetic," Colvin and Cheney. This is a book that no person engaged in mechanical occupations can afford to do without. Enables any workman to figure out all the shop and machine problems which are so puzzling for want of a little knowledge. We sell it for 50 cents.

"Firing Locomotives," Sinclair. Treats in an easy way the principles of combustion. While treating on the chemistry of heat and combustion, it is easily understood by every intelligent fireman. The price is 50 cents.

"Skeevers' Object Lessons," Hill. A collection of the famous object lesson stories which appeared in this paper several years ago. They are interesting, laughable, and, best of all, they are of practical value to-day. \$1.

"Standard Train Rules." This is the code of train rules prepared by the American Railway Association for the operating of all trains on single or double track. Used by nearly all railroads. Study of this book would prevent many collisions. Price, 50 cents.

"Mechanical Engineers' Pocket-book," Kent. This book contains 1,100 pages, 6x3¼ ins., of closely printed minion type, containing mechanical engineering matter. It ought to be in the bookcase of every engineer who takes an interest in engineering questions. We use it constantly as a reference for questions sent to us to be answered. Full of tables and illustrations. Morocco leather, \$5.00.

"Locomotive, Simple, Compound and Electric," Regan. An excellent book for people interested in any kind of locomotive. It will be found particularly useful to men handling or repairing compound locomotives. It is the real locomotive up to date. \$2.50.

"Simple Lessons in Drawing for the Shop," by O. H. Reynolds. This book was prepared for people trying to acquire the art of mechanical drawing without a teacher. The book takes the place of a teacher, and has helped many young men to move from the shop to the drawing office. 50 cents.

"Locomotive Running Repairs," by L. C. Hitchcock. This book contains directions given to machinists by the foreman of a railroad repair shop. It

tells how to set valves, set up shoes and wedges, fit guides, care for piston packing, and, in fact, perform all kinds of work that need a thoughtful head and skilful hands. 50 cents.

"Care and Management of Locomotive Boilers," Raps. This is a book that ought to be in the hands of every person who is in any way interested in keeping boilers in safe working order. Written by a foreman boilermaker. Also contains several chapters on oil-burning locomotives. 50 cents.

"Locomotive Link Motion," Halsey. Any person who gives a little study to this book ceases to find link motion a puzzle. Explains about valves and valve motion in plain language. Price, \$1.00.

On the morning of May 9th, fire broke out in the plant of the Falls Hollow Staybolt Co., Cuyahoga Falls, Ohio, while the mill was in operation, the night staff just working the last heat of the night shift. Considerable damage was done to a portion of the roof of the main building, which, however, did not interfere with the operation of the mill for more than twenty-four hours. This fire was of little consequence, and the filling of orders was not delayed. This company want their customers to understand that there will be but little delay if any in filling new orders.

The Smooth-On Company of Jersey City have recently issued the second edition of their No. 5 Instruction Book. This book tells a few of the many ways in which the different Smooth-On specialties have been used



IN THE "PLEASANT LAND OF FRANCE."

and the results obtained. It is a very interesting book and valuable to all manufacturing concerns, especially to users of steam. The book will be sent free to any one sending his name and business address direct to the company.

The Board of Directors of the William C. Baker Heating & Supply Company have declared a semi-annual dividend of one and one-half (1½) per cent., upon the capital stock of the company, payable at the office of the company, 143 Liberty street, New York, on and after May 27th, 1907, to stockholders of record at the close of business on that day.



### Shop Betterment.

As the committee appointed to handle this topic did not report at the recent meeting of the General Foremen's Association, an emergency committee drew up the following report, which will be read with interest.

Under the first sub-head, "How Can Output of Shop Be Increased by Reconstruction of Old Machine Tools," there is this that may be said: The machine builders as yet have not produced a tool sufficiently heavy to give the maximum output of heavy self hardening steels. By this we do not mean that there are not isolated cases where such tools have been produced, but generally speaking the manufacturer has not kept up with the

The field is broad enough to merit close consideration, as in our judgment there is a tendency to rush into the purchase of the modern machine tools and equipment without considering the matter from a financial viewpoint; without first figuring and thus being in a position to know whether the new machine will pay interest on the money invested, and whether the difference in price is warranted or otherwise.

Under the second sub-head—"Maintenance and Proper Distribution of Small Tools"—among other things there is this may be said: Unless the plant is abnormally large, we see no reason why small tools other than the rough tools, which are the natural equipment of the

synonym for money. There is certainly no economy in permitting a machine to take an air tool from the tool room or other place of storage, connect it up and get it in shape to use, only to find at the last moment that the anticipated result is not to be obtained with that particular machine. It would, in our judgment, be much better practice to have a particular place to which these tools be returned at stated intervals for inspection, lubrication and repair. We do not think that an air tool should be kept in service longer than seven days without this inspection, believing that in this case, as well as in nearly all others, "a stitch in time saves the proverbial nine." We realize that pneumatic tools have now become the



TRACK TANKS ON THE N. Y. & L. B., NEAR LONG BRANCH, N. J. ENGINE SCOOPING UP WATER.

Copyright, 1894.

By F. W. Blauvelt, N. Y.

steel manipulator. The machine tool, constructed a dozen or less years since, with some necessary changes—increased belt widths and lap on cones, slightly enlarged bearings and heavier tool rests—will produce nearly as satisfactory results as some of our modern machines; possibly there are some machines that could be specialized to such an extent that they would handle work for which they were not originally designed, equally as well if not better than a tool made for that particular class of work. If upon investigation we find this to be true, then the purchase of a new tool is a waste.

mechanic, should not be kept in a tool room, repaired therein and checked therefrom. A tool which is not always in usable condition is worthless and is a very expensive thing. Therefore, the tool room should be so systematized that the tool checker will have no tool in his racks from which maximum and economical service cannot be obtained.

Under the third sub-head—"The Care of Air Tools"—there is this one particular point to make: Air tools represent quite a large investment. If an air tool is not in shape to produce maximum results there is a great loss of labor—the syno-

most important portable tools in the modern shop. We should also realize that it is necessary, in view of the changes in personnel which continually occur in the working force, the necessity for educating each man in the care of these tools in order that money be saved to the corporation which we represent, and that the efficiency of the shop under our management be not impaired.

Fourth sub-head—"Special Devices, Jigs, Templates and Use of Same." Wherever possible and wherever there is necessity for the duplication of any number of parts, we believe it is economy to

have jigs and templates of proper design kept in some central and easily accessible place for use in connection therewith. Certainly a jig or template of proper design will produce better results than calipers or scales, and there will be less liability of error—in fact, practically none—due to mismeasurements or misapprehension of sketches or drawings. We, therefore, commend the use of jigs, templates and other devices which tend to simplicity in manufacture.

"The necessity of having one main tool-making plant for large railway systems and for distribution of tools to outlying points." The truth of the above has been demonstrated, and it is in process of demonstration on many railway systems at the present time. We believe that there is no question of the economy in the manufacture of tools at a central point where all necessary equipment may be located, and a system of standardization, elaborated and proper tempering facilities installed. Certainly it is cheaper to manufacture an article in quantities than in units; certainly better results should be obtained from a quantity of articles manufactured by one, two or more men under one supervisor, than could be possible if manufactured in a dozen different places under an equal number of supervising heads. Therefore, we contend that it is proper, economical and better practice to standardize, manufacture and distribute all shop tools for railway systems at one central point.

To continue with the paper under headings not mentioned in the published topic "sub-divisions," we find that in general there is a lack of proper and conveniently located toilet facilities for employes. Without going into further detail we would recommend the consideration of this very important detail in shop economy to railway managements everywhere. In conclusion your emergency committee desires to say that in its judgment there is nothing that tends to produce better results, create a better feeling or a more cheerful disposition among men than a clean, well ventilated and well lighted place to work in. These matters are of the first importance and should receive prime consideration in the construction of new or the reconstruction of old plants.

#### Cushioned Non-Return Valve.

These valves can be used as a part of the general piping system of power stations regardless of size plant or pressures, and as they are made in the Angle or Straightway pattern, they can be used in vertical or horizontal piping. They are adapted to high steam pressures and are made so as not to chatter, hammer or stick.

These valves, when placed between the boiler and header, are designed to equalize the pressure between the different units of a battery of boilers. It

is claimed that they will remain closed as long as the boiler pressure is lower than that of the header. When the boiler pressure equals that of the header they thus automatically cut off a boiler in case of accident, such as the bursting or collapsing of a tube and also act as a safety stop to prevent steam from being turned into a cold boiler, which means a safeguard for men, when working inside.

Referring to the sectional illustration the dash-pot arrangement for cushioning these valves may be seen. This is intended to avoid chattering, hammering or sticking of the valves. The inside bronze dash-pot is firmly attached to the valve spindle, while the outside bronze dash-pot is loose on the spindle, free to move in the body, like a Corliss dash-pot occupying the

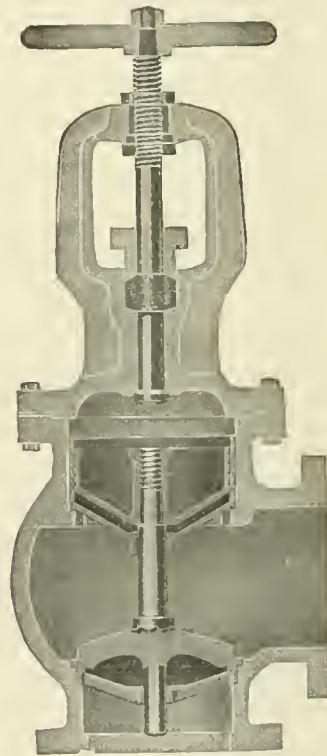

SECTION OF NON-RETURN VALVE.

full area of the body with perfect alignment of the valve with the seat. When the steam pressure raises the valve, there exists space between the inner and outer dash-pots. The outer dash-pot being loose on the spindle allows steam to pass between the dash-pots, also permits the circulation of steam around the outside dash-pot through the several vertical grooves cut in the upper portion of the body, and condensation is eliminated by this means.

These valves are made of cast iron, semi-steel or steel, fitted with brass, bronze or nickel bronze in accordance with specifications. The Golden-Anderson Valve Specialty Company of Pittsburgh, Pa., will be happy to forward descriptive circulars concerning these valves.

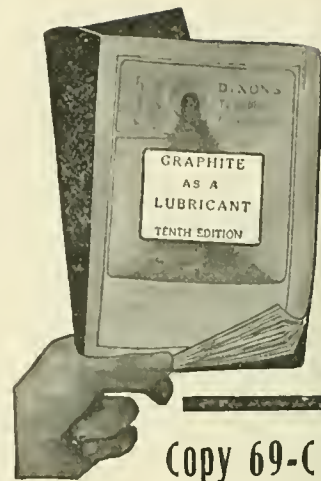

Copy 69-C FREE

Here is a complete and interesting story of graphite and its development as a lubricant. You can not get in any other book of equal size so much information of REAL value. The experience of practical men and the experiments of scientific authorities are both given in this TENTH EDITION of

## "Graphite as a Lubricant"

making it valuable to men of practice and students of theory.

Lubrication in almost every kind of machinery is treated of. "Kinks" and "short-cut" methods discovered and used by resourceful engineers are included.

You should get this book now. Write for FREE copy 69-C.

**JOSEPH DIXON  
CRUCIBLE CO.  
Jersey City, N. J.**

# GOLD Car Heating and Lighting Co.

Manufacturers of

**ELECTRIC,  
STEAM AND  
HOT WATER  
APPARATUS  
FOR RAILWAY CARS**

**EDISON  
STORAGE  
BATTERY  
FOR RAILWAY CAR  
LIGHTING**

**Largest Manufacturers in the World  
of Car Heating Apparatus**

**Catalogues and Circulars  
cheerfully furnished**

**Main Office, Whitehall Building  
17 BATTERY PLACE  
NEW YORK**

**Italian Compound 4-6-0 Express.**

This engine was shown at the Milan Exhibition last year and represents a numerous class now in service on the Italian State railways. They work the principal express trains between Milan-Rome, Venice-Turin, etc.

As will be seen, the cab and firebox of this engine are placed over the leading bogie, and the smokebox behind. It has by this means been possible to get a width of grate of 59 ins. and an area of 32.59 sq. feet, as the coupled wheels are not in the way. The grate is, however, comparatively short, being only 6 ft. 7½ ins. long. The four cylinder system of compounding is adopted, and the cylinders are placed side by side, driving the centre coupled axle.

The chief dimensions are as follows:

- Diameter of H. P. cylinders, 14½ ins.
- Diameter of L. P. cylinders, 23½ ins.
- Stroke of pistons, 25½ ins.
- Diameter of driving wheels, 6 ft. 3½ ins.

and compressor, being placed upon one car, either a standard flat or of special design having storage tanks, etc., under the floor. Such a car is fitted with standard trucks, and can be used at any point on the road, and is very handy for operating a sand blast, running pneumatic hammers on bridge work, operating painting machines, or for pneumatic cassion work. They also build an equipment similar to this flat car equipment, but it is all mounted on one independent base, which base can be set on and taken off an ordinary flat car, thus making a semi-portable outfit.

There are several advantages in connection with the gasoline air compressor, as a great deal of the work on railways has to be done in cities and about stations where a steam compressor would be more or less objectionable; the water question is sometimes a serious one, and the gasoline engine is ready to operate at

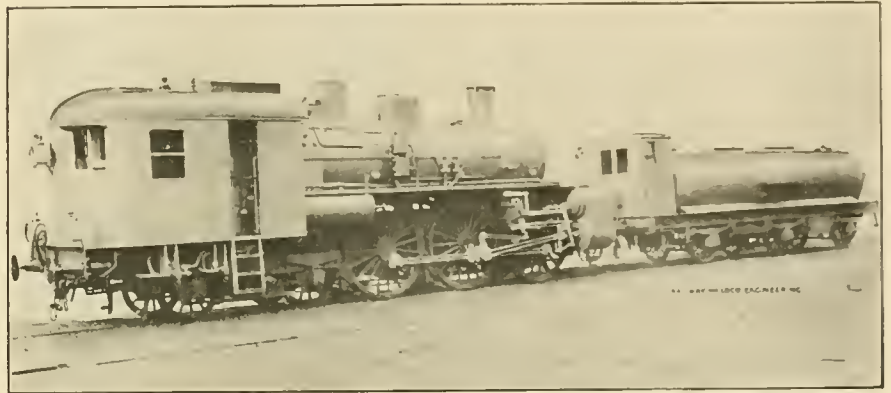

ITALIAN COMPOUND 4-6-0 ENGINE. USUALLY RUNS CAB FIRST.

- Diameter of bogie wheels, 3 ft. 7 ins.
- Boiler pressure, 213 lbs. per sq. in.
- Heating surface, 1,650 sq. ft.
- Grate area, 32 sq. ft.
- Coal capacity, 4 tons.
- Total weight of engine, 69½ tons.
- Total weight of tender, 36½ tons.
- Tender carries 4,400 gallons.

**Gasoline Engines in Railway Work.**

The gasoline engine is gradually taking its place as standard equipment on many of the large and prominent railway systems in the country. We are informed by the New York office of the Otto Gas Engine Company that they have been successful in building up a very satisfactory and substantial business along the lines of gasoline pumping engines, special electric engines for charging storage batteries on signal service and station lighting, coaling stations, draw bridges, turntables, sand blast, compressed air, etc.

One of the new uses for the gasoline engine, as developed by this company, is a pneumatic tool car which consists of gasoline engine directly geared or connected by silent chain to an air compressor; the engine and compressor, together with suitable tanks for both engine

any time with comparatively little attention.

Another specialty made by the Otto Gas Engine Works is turntable engines. They build three distinct types of machines for this purpose—single cylinder vertical, single cylinder horizontal and multiple cylinder vertical engines. On account of the increased weight of locomotives and the increased speed required on turntables, we are informed that while turntable engines were first put out by this company from three to four horsepower, that they are now equipping turntables with from eight to twelve horsepower.

The Otto Gas Engine Works, particularly through their Chicago branch house, have made a specialty of high grade railway equipment, the Chicago office having been for many years in charge of Mr. T. W. Snow, one of the best informed men concerning the equipping of railroads in the West. Mr. T. W. Snow was elected president of the Otto Gas Engine Works in September, 1906.

The Otto Gas Engine Works also build the Otto Patent Flexible Spout Standpipe, together with a full line of tank fixtures,

water tanks and stand pipes, both the intermittent and continuous water softening systems, and control the Davidson patents for that system of automatically measuring water and chemicals in the proper proportions without any outside expense. Printed matter, plans and specifications will be furnished describing the Otto line of goods upon application to the Otto Gas Engine Works, 136-138 Liberty street, New York City, or 357 Dearborn street, Chicago, Ill.

**Speed and Safety.**

The following is an extract from a very comprehensive circular issued by Mr. Daniel Williard, second vice-president of the Chicago, Burlington & Quincy Railway. It is addressed to engineers handling passenger trains and others connected with that service. Mr. Williard, who is in charge of operation on that road, speaks as follows in one part of this circular.

"While we are anxious, of course, to have all trains run as nearly as possible on time, still this further thought should be kept in mind, that the first consideration should at all times be given to the safety and comfort of passengers. There is hardly any piece of main track on the Burlington Line that will not ride smoothly at some certain rate of speed, and it may probably also be said that there is hardly any piece of track on the Burlington or any other railroad which would not ride improperly if run over at too high a rate of speed. Engineers who are constantly running over the same piece of road soon learn its character-

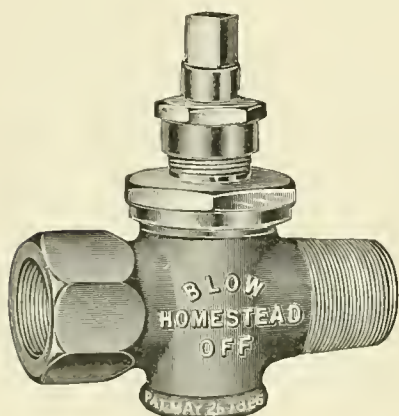

HOMESTEAD BLOW-OFF VALVE.

istics, and they should regulate the speed to suit the conditions. The engineer who can make the required time, and at the lowest maximum rate of speed, is the man who excels as a runner, and to accomplish this it is necessary to get the train quickly in motion after stops, maintain required speed to reach the next stop at the proper time, and do all that rests with him to do to reduce delay at stations to the lowest possible limit."

**Locomotive Blow-Off Valve.**

The Homestead locomotive blow-off valve is used on many of the large railroads in the country. It is also largely used in stationary work for either water, steam or air. The locomotive blow-off valve is made on the same principle as the straightway

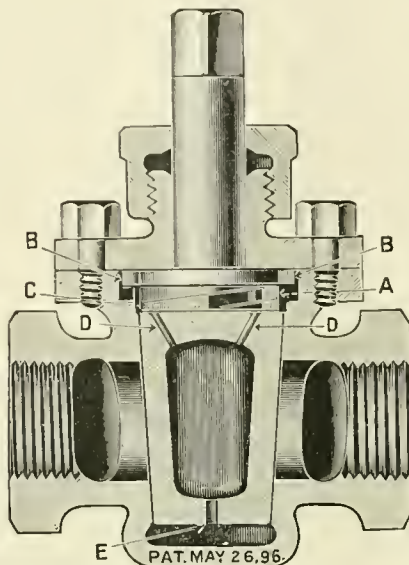

SECTION OF BLOW-OFF VALVE.

valve. It will be seen that when the pressure passes through this valve that the seat is protected from wear. The valve is so constructed that when it is closed it is at the same time forced firmly to its seat. This result is secured by means of the traveling cam through which the stem passes. The cam is prevented from turning with the stem by means of lugs which move vertically in slots. Supposing the valve to be open, the cam will be in the lower part of the chamber in which it is placed and the plug will be free and can be easily moved. A quarter of a turn in the direction for closing it causes the cam to rise and take a bearing on the upper surface of the chamber, and the only effect of any further effort to turn the stem in that direction is to force the plug more firmly to the seat. A slight motion in the other direction immediately releases easily, being arrested at its proper open position by contact of the fingers of the cam at the other end of its travel. There are also balancing ports which allow the pressure to predominate at the top of the plug, and this pressure of steam holds it gently in its seat while the valve is open. This valve is made in all sizes up to 6 ins., and is said by the makers to be capable of standing all pressures up to 5,000 lbs. It is also made in 3-way and 4-way patterns by the Homestead Valve Manufacturing Company, of Pittsburgh, Pa.,

## RUBEROID ROOFING

FOR

CARS SHOPS  
CABS ROUND HOUSES

Contains no tar. Will not melt, rot, crack or corrode.

Not affected by extremes of temperature. Highly fire resisting.

Spark-Proof Cinder-Proof  
Gas-Proof Weather-Proof

Write for samples and prices.

**THE STANDARD PAINT CO**  
100 William St., New York.

Boston, Chicago, St. Louis, Kansas City,  
Philadelphia, Atlanta.

## Ball's Official R.R. Standard Watches

**16 AND 18 SIZE**

**17 and 21 Ruby Jewels, Sapphire Pallets**

**Ball's Improved Safety Double Roller**

Are without question the finest watches that American talent and skilled labor can produce, and they are giving such universal satisfaction that we have no hesitancy in claiming that they are the best and safest railroad watch on the market.

Tests severe and numerous have proven this fact to the most critical users in all sections of the country, to which thousands of good Railroad and Brotherhood men are ready to certify.

We have an authorized agent in nearly every railroad center. Call on him for information and facts. Write us for descriptive matter.

**The Webb C. Ball Watch Co.**  
Watch Manufacturers  
Ball Building, Cleveland, Ohio, U. S. A.

# Patents.

**GEO. P. WHITTLESEY**

MCGILL BUILDING WASHINGTON, D. C.  
Terms Reasonable Pamphlet Sent

**JUST PUBLISHED**  
**The Walschaert**  
**Locomotive Valve Gear**

By W. W. WOOD.

Nearly 200 pages.

Fully Illustrated.

PRICE \$1.50



The only book issued that is devoted exclusively to the Walschaert Valve Gear, and it fills a demand which, during the last few months, has become very important. If you would thoroughly understand the Walschaert Valve Gear you should possess a copy of this book, as the author takes the plainest form of a steam engine—a stationary engine in the

rough, that will only turn its crank in one direction—and from it builds up—with the reader's help—a modern locomotive equipped with the Walschaert Valve Gear, complete.

The points discussed are clearly illustrated; two large folding plates that show the position of the valves of both inside or outside admission type, as well as the links and other parts of the gear when the crank is at nine different points in its revolution, are especially valuable in making the movement clear. These employ sliding cardboard models which are contained in a pocket in the cover.

The book is divided into four general divisions, as follows: I. Analysis of the gear. II. Designing and erecting the gear. III. Advantages of this gear. IV. Questions and answers relating to the Walschaert Valve Gear, which will be especially valuable to firemen and engineers preparing for an examination for promotion.

Just Issued—1907 Revised and Enlarged Edition.

UP-TO-DATE

**AIR BRAKE CATECHISM**

By ROBERT H. BLACKALL.

PRICE \$2.00

The Standard Book on the Air Brake. Contains over 2,000 Questions and Answers giving a detailed description of all the Old Standard and Improved Equipment.

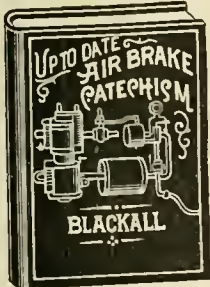

Owing to the many changes and improvements made in the Westinghouse Air Brake it has been found necessary to issue the new, revised 1907 edition of the Air Brake Catechism, which contains all the latest information necessary for a railroad man to pass his as well as the

examination on the new older style of brake.

The new revised 1907 edition is right up to date and covers fully and in detail the Schedule E. T. Locomotive Brake Equipment, H-5 Brake Valve, SF Brake Valve (Independent), SF Governor Distributing Valve, B-4 Feed Valve, B-3 Reducing Valve, Safety Valve, K Triple Valve (Quick-Service) Compound Pump.

Send for a special circular of these books as well as our Other Railroad Books. Copies of these books sent prepaid on receipt of price.

**Agents Wanted** Write for our special terms. You can make equal to a month's pay selling our books on the side.

**The Norman W. Henley Publishing Co.**  
 132 Nassau St., New York, U. S. A.

who will be pleased to send descriptive booklet to anyone who is interested enough to apply to them.

The Cleveland Twist Drill Company, of Cleveland, Ohio, have issued a set of five ready reference cards which are intended to be hung up in a foreman's office or anywhere else that twist drill information is required. The cards are furnished with a brass ring, so that they can be put up on a nail or hook or taken down most readily. One of the cards gives a table of cutting speeds. Another gives the proper dimensions of the drill shank for different sizes. Another gives the parts of an inch in decimals for use with micrometer calipers. Another is a drill list for taps with "V" threads, also standard U. S. threads, and for machine-screw taps. Another sets forth the U. S. standard system of bolts and nuts, and the last card has hints on the use of high-speed drills and sug-

**Great Northern Motor Car.**

Nearly all of the British railways are running rail motors for service on short branch lines. The one shown in our illustration has recently been put into service on the Edgware Branch of the Great Northern Railway. The car body is 49 ft. long and has seating accommodation for 53 passengers. It is carried on a standard carriage bogie at one end, and on four coupled wheels of 3 ft. 8 ins. in diameter under the engine. Other leading dimensions are, cylinders 10 by 16 ins., diameter of boiler barrel 4 ft. ½ in., firebox casing 3 ft. 6 ins. by 4 ft. ½ in., 178 tubes, heating surface 382 sq. ft., grate area 9½ sq. ft., boiler pressure 175 lbs. per sq. in.

**Perolin.**

Announcement has just been made of recently completed arrangements by which the H. W. Johns-Manville Co., of New York, the well-known asbestos



RAIL MOTOR CAR ON THE GREAT NORTHERN OF ENGLAND.

gestions for the regrinding of drills. These ready reference cards are useful to anyone who has to use twist drills, and they can be had by the person who writes to the Cleveland Twist Drill Co. This company expects to close down for the first two weeks in July for the purpose of stock-taking and repairs to plant. They hope their friends will, as far as possible, anticipate this date with their orders, so that no delay in delivery will occur owing to the short, temporary closing of the works. The office will be open all the time as usual.

firm, with branches in all the leading cities, have acquired the exclusive sales agency for "Perolin" throughout the United States. Perolin is a remarkable product that is intended to solve the important problem of preventing the dust and dirt nuisance in public buildings, stores, work shops, factories, schools and homes. Perolin is said to be a fireproof floor cleaning compound. Instead of laying the dust—it absorbs it. It is a disinfectant, destroying all disease germs that are common with dust; leaving the air pure and wholesome, and the floor clean.

The Whiting Foundry Equipment Company of Harvey, Ill. (a suburb of Chicago), are the manufacturers of cranes and foundry equipment. They announce the appointment of a new Southern representative, Mr. H. W. Canning, whose headquarters are in the Brown-Marx Bldg., Birmingham, Ala.

The Johns-Manville Company informs us that a test was recently made in one of the Chicago hospitals, to ascertain the number of living germs floating in the air, before and after ordinary sweeping, and after sweeping with Perolin. Before sweeping the room, it was found that 96 bacteria settled on a plate in four minutes. Immediately after sweeping, a similar test showed over 3,000 bacteria. A test was then made by thoroughly sweeping the

room with Perolin, and only 45 bacteria were found on the plate.

Perolin is said to be the original sweeping compound, having been invented over fifty years ago by a well-known German chemist. It has long been a standard article throughout Germany, and its success there led to its introduction into the United States.

**Mechanical Engineers' Meeting.**

The semi-annual meeting of the American Society of Mechanical Engineers was held in Indianapolis, Indiana, May 28th to 31st, and was of interest to mechanical engineers. A wide range of subjects was taken up and discussed, among which were reports of committees on standard proportions for machine screws; standard tonnage basis for refrigeration, and papers on pumping engines, the heating of storehouses, and kilns for Portland cement. Special sessions for papers and discussions of superheated steam, including papers on its specific heat, its flow, furnace and superheat relations, the determination of entropy lines for superheated steam, the performance of Cole superheaters, superheated steam in an injector, the use of superheated steam on locomotives in America, analysis of locomotive tests, and material for the control of superheated steam.

Several excursions took place to different plants and points of interest in and around Indianapolis. One of the professional sessions devoted to superheated steam was held at Purdue University, and an opportunity was thus given to the guests of going over the university. The Local Committee at Indianapolis secured reserved seats for those attending the convention, upon the occasion of President Roosevelt's speech at Indianapolis on Decoration Day. On Wednesday afternoon, May 29th, a visit was made in special cars to the Atlas Engine Works, and the National Motor Vehicle Co. Another excursion on the same afternoon was arranged for the D. N. Perry Mfg. Co. and to the Nordyke & Norman Co.

Spring painting is a seasonable or timely heading for the little folder now issued by the Joseph Dixon Crucible Company, of Jersey City, N. J. Talking of timely, did it ever strike you that the word "tidy" in its original sense meant seasonable? The word "tide" meant "time" in olden days; "eventide" is an example of that former meaning. Things done in the right time are likely to be in the right place, so the change in meaning was quite natural and logical. What was timely or seasonable is most likely to be tidy, and it is not a very great stretch of the imagination to see that to go into spring painting will make things look tidy. The Joseph Dixon Company,

like most of us, believes that spring is the renewal season of nature, and a new technical book called the "Philosophy of Protective Paint" issued by them, and sent free on request, tells us that among the provisions of Nature is a dark gray ore found at Ticonderoga, N. Y., which may be used as a renewer or rather as a preservative of wood and metal when used in the form of paint. This Ticonderoga mineral is flake graphite, and when properly mixed with linseed oil makes things not only tidy, but makes them resist deterioration. Write to the Dixon Company and get the book if you have any structural work to protect, or even if you want to know how to make things look neat at this season of year. They will consider your request tidy in the sense that it is timely or seasonable.

From their new works, occupying the whole of the west side of 13th street between St. Paul avenue and the



TRANS-CAUCASIAN RAILWAY EXPRESS ENGINE OIL BURNER.

tracks of the Chicago, Milwaukee & St. Paul Railway, the Bliss Electric Car Lighting Company of Milwaukee have shipped to Atlantic City the exhibit to be installed on the Steel Pier during Convention Week. This exhibit consists of complete 30 volt and 60 volt equipments for electric car lighting, and will afford railway men attending the Convention a practical demonstration of the workings of the Bliss System. The equipments are to be operated on the pier under the conditions that will closely simulate those encountered in actual service and the method of installing the axle-driven generator, the "bucker" regulator, and the other parts of Bliss System will be clearly demonstrated. The Bliss Company's exhibit will occupy spaces 1201 to 1207 inclusive, on the south, or "sunny side" of the Steel Pier. Mr. W. L. Bliss, Col. Jno. T. Dickinson and Mr. F. Urban, president, vice-president and general manager of the Bliss Electric Car Lighting Co., will be in charge of the exhibit; assisted by Mr. W. L. Lalor, manager of the Chicago office; Mr. Robert C. Schaal and others.

# The Cheer of The Man Who WINS

The man who wins a good position and a high salary is entitled to cheer.

He has accomplished something worth while. And yet it is really easy—yes it is easy for YOU to gain a better position, increased earnings, and a successful life. The experience of

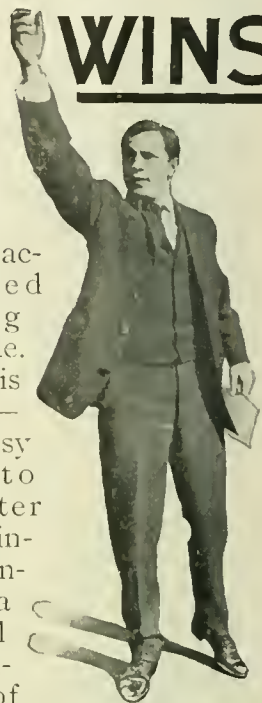

hundreds of thousands of men who have followed the I. C. S. road to success proves this unquestionably. No matter how poor your circumstances are, the I. C. S. can adapt its six-million-dollar system of salary-raising training to your own individual needs and help you to secure promotion. You, in your own home and in your spare time, can easily do this and can find out how by simply marking and mailing the coupon below. Will you let a postage stamp prevent your winning a better position?

**International Correspondence Schools**  
BOX 805, SCRANTON, PA.

Please explain, without further obligation on my part, how I can qualify for a larger salary and advancement to the position before which is marked X.

General Foreman R. R.	R. R. Co.'s Engineer
R. R. Shop Foreman	Civil Engineer
R. R. Trav. Engineer	Bridge Engineer
R. R. Trav. Fireman	Chemist
Locomotive Engineer	Mining Engineer
Air-Brake Instructor	Architect
Air-Brake Inspector	Bookkeeper
Air-Brake Repairman	Stenographer
Mechanical Engineer	Ad. Writer
Mechanical Draftsman	French } With
Machine Designer	German } Edison
Electrical Engineer	Spanish } Phonograph

Name \_\_\_\_\_  
 St. & No. \_\_\_\_\_  
 Employed by \_\_\_\_\_ R. R.  
 City \_\_\_\_\_ State \_\_\_\_\_

# Tate Flexible Staybolt

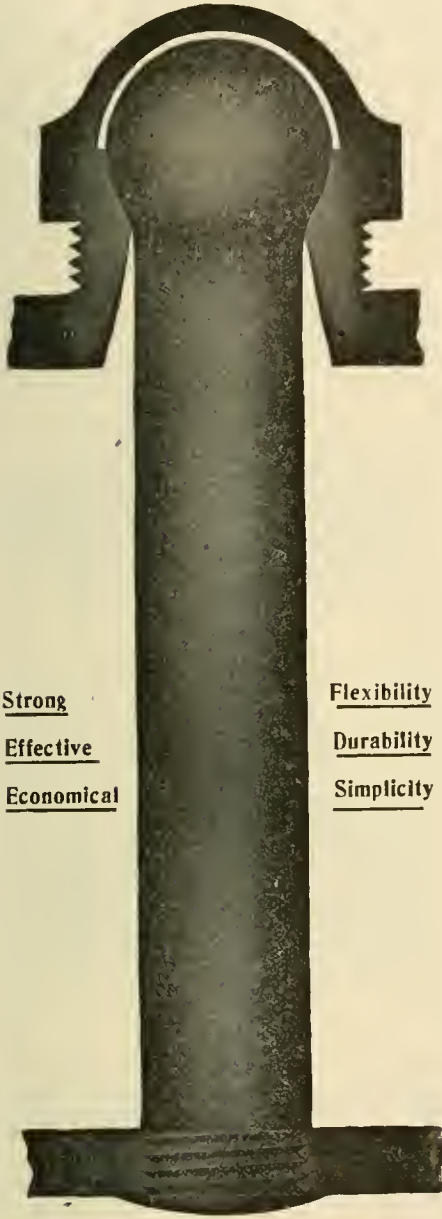

Strong  
Effective  
Economical

Flexibility  
Durability  
Simplicity

Holds firebox sheets securely together, and accommodates itself to the unequal expansion of the plates.

## FLANNERY BOLT COMPANY

PITTSBURG, PA., U. S. A.

Suite 308, Frick Bldg.

B. E. D. STAFFORD, - - General Manager  
Write us for Reference Book

### Threading and Cutting Machine.

Our illustrations show the Improved Armstrong Pipe Threading and Cutting Off Machines. They are made in five different sizes, and each has a large range. There is a practical unity of design running through the series, which ranges from No. 0, taking from 1/4 to 2 in. pipe, and weighing 135 lbs. with dies, cutting by hand or power, up to

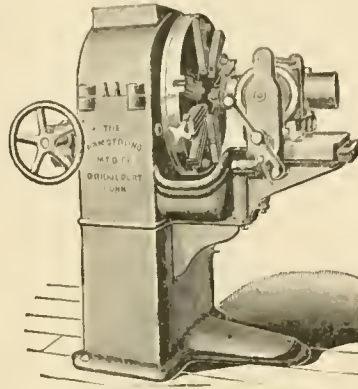

FIG. 1. LARGE SIZE POWER MACHINE.

the 1,250 lb. power machine No. 3, which cuts and threads pipe from 1 to 6 ins., inclusive. This machine is illustrated in Fig. 1. These machines are also available for threading bolts, the No. 0 machine taking bolts from 1/2 up to 1 1/2 ins. in diameter, and thus making a combination thread and bolt machine. Pipe is gripped in a powerful, self-centering vise, secured by lugs to a post, bench or any temporary support in case of the smaller machines, and permanently built into the stand in the larger sizes. The vise handle is arranged to be out of the way of the operator when threading or cutting, yet always accessible for changes of adjustment.

Immediately in front of the vise is the die head, carrying a machine counterpart of the Armstrong adjustable stock for hand threading, the die being divided into from two to eight sections, according to the size of pipe. In the two-jawed dies adjustment is made by individual end screws, but in the larger sizes the turning of a single screw moves all the die sections simultaneously like the jaws of a lathe chuck. The dies used with these machines are of the Armstrong make, with their characteristic adjustable features and double taper. They are furnished right or left, for pipe or bolts, as may be desired. The die head has no gear teeth on the part coming in contact with the shell, while a large bearing insures firmness and little wear. The driving spindle is carried through the side, and its end is squared in No. 0 machine, and provided with a key in the larger sizes, so that a hand crank or power pulley can be slipped on or off at a moment's notice. The No. 0, machine

has a geared spindle in addition to the main driving spindle, so that two speeds are provided, enabling small pipe to be threaded very quickly when the handle is on the main spindle, and giving less speed and more power for pipe from 1 1/4 to 2 ins. by changing the handle to the geared spindle.

After the pipe has been threaded a simple motion of the hand wheel or lever causes the dies to open. The vise is loosened, the pipe pushed through until the desired length comes beyond the center point, then a few turns of the working handle finish the cutting off, the action being automatic. All the parts of these machines are numbered, and are fitted to be interchangeable with others of the same number. These machines will thread and cut off a 1/4-in. pipe in 2 1/2 minutes, and a 6-in. pipe in 4 minutes, with proportionate time for intermediate sizes. As all the gears and bearings are enclosed in a dustproof oil chamber, lubrication is ensured, as well as protection from dust, dirt and metal chips. The compactness and simplicity of these machines, together with their small weight, have won for them a very large and increasing market. All sizes up to No. 00, shown in Fig. 2, which will cut 4-in. pipe, can readily be moved about

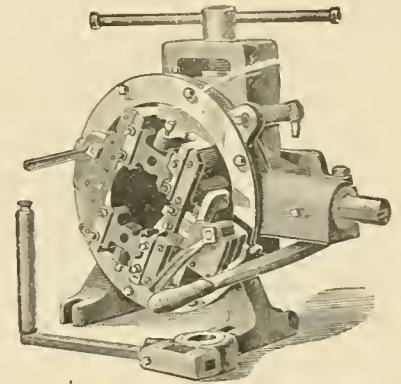

FIG. 2. SMALL PIPE MACHINE.

for outside work. The Armstrong Mfg. Co., of Bridgeport, Conn., will be happy to give any further information on the subject to anyone who will apply to them direct.

There has just come to our office a very neat and useful catalogue issued by the Pratt & Whitney Company, Hartford, Conn., which has been got out by their small tool department. It is very finely illustrated, and contains information concerning taps and dies, die stock sets for bolt and pipe threading, milling cutters, slitting saws, Renshaw ratchet drills, lathe tools, twist drills, boiler punches, reamers, taper pins, etc. This is Catalogue No. 4, and supersedes all previous editions. It gives hints on ordering which are useful to intending purchasers. The price list is also included

on many of the pages. It contains 215 pages, and is altogether a handy reference book concerning the articles with which it deals. A copy may be had by applying direct to the Pratt & Whitney Company, either at their main office in Hartford, or at their New York office, which is at 111 Broadway.

#### Rail Breakages.

The Railroad Commission of the State of New York has completed an investigation into the breakage of rails on the principal railways which come under their jurisdiction. The breakages occurred during the months of January, February and March of this year. There was a total of 3,014 breakages on the principal steam lines of the State, and during the corresponding three months of 1906 there was a total of 826, and during the corresponding three months of 1905 there was a total of 1,331.

The matter was presented to the American Railway Association, and that body is looking into the whole question and proposes to ask the United Steel Corporation to draw up specifications of chemical composition and manufacture of rails, and then not to deviate from those specifications. The commission also desires that the matter be taken up for discussion and action by the various railway managers. A conference is likely to be arranged with rail manufacturers with a view to discovering if the number of breakages is due to method of manufacture or metal composition.

One part of the commission's report analyzes the totals as to weight of the rails, and shows that while the breakage in 1905 and 1906 was chiefly in the eighty-pound rails, the largest number in the quarter just passed was in the hundred-pound rails. The other table analyzes the figures as to date when the removed rails were rolled, showing heaviest breakage totals in rails rolled since 1899, and especially in those rolled in 1904, 1905 and 1906.

#### Rock Drill Catalogue.

An artistically printed catalogue of the Chicago Giant Rock Drills and kindred appliances is being sent to the trade by the Chicago Pneumatic Tool Company. The book is printed in colors on high grade paper and contains ninety-six pages of matter referring to rock drills. The text is well written and fully explanatory, and is embellished with half-tone engravings illustrating the Chicago Giant Rock Drills and views of parts, followed by several pages devoted to rock drill steels and an interesting description of the method of lubrication used in the Chicago Giant, which is one of the distinguishing features of the drill. Several pages are devoted to Franklin Air Compressors, another of the company's prod-

ucts, followed by illustrations and descriptions of the Baby Giant or One Man Rock Drills, at work. Catalogue No. 22 is the title of the book. Copies will be forwarded upon request by addressing the Chicago Pneumatic Tool Company, Fisher Building, Chicago, or at 95 Liberty Street, New York, N. Y.

What is called a phantom view of the Gould M. C. B. journal box is given in an excellently printed and illustrated folder got out by the Gould Coupler Co., of New York. The phantom style of illustration might with equal propriety be called a transparent view, and is such as we use in some of our educational charts. The one issued by this coupler company shows the outside of the box and through it may be seen the journal, wedge and brass all in place. Another view, which is reproduced from a regular photograph, shows the inset journal box lid, which forms an effective dust excluder. This box is also fitted with an improved dust guard, which is composed of a number of layers of heavy canvas or duck, secured together and arranged with stiffeners. This material is used, for when saturated with oil it does not matt or glaze. This guard can be put in position from the front of the box when the journal is in place. The folder will be mailed to any address by the Gould Company on receipt of a request from anyone interested in this axle-box or its accessories.

#### Opening of Illinois Traction System.

The first section of the alternating current system of the Illinois Traction System was opened between Peoria and Bloomington, April 21st. On that date a regular schedule was put into operation, cars leaving the terminal stations on the odd hour throughout the day from 5 A. M. to 11 P. M. Beyond the usual delays incident to warming up new equipment, the single phase motors and auxiliary apparatus worked well. This road is one of the four single phase lines in the Middle West which have adopted single phase alternating current apparatus made by the General Electric Company. On Sunday, April 28th, special rates between the various stations were advertised by circulars, the cost of one round trip from Peoria to Bloomington being fixed at \$1.00.

At the annual meeting of the stockholders of the Joseph Dixon Crucible Company, of Jersey City, N. J., the old board was unanimously re-elected. The board of directors re-elected the former officers, and Joseph D. Bedle was also re-elected as counsel.

## Homestead Valves

Straightway. Three-way and Four-way.  
and

## Homestead Locking Cocks

Are Famous the World Over

They cost more, but are worth very much more than other makes. You try them and see.

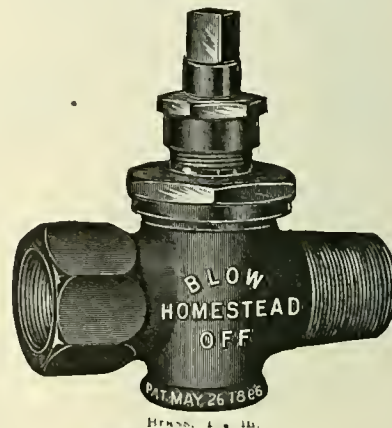

Iron Body, Brass Plug, 1 1/4 in.

**HOMESTEAD VALVE MFG. CO.**

WORKS:  
HOMESTEAD, PA. PITTSBURG, PA.

## American Locomotive Sander Company

13th & Willow Sts., Philadelphia, Pa.

Proprietors and Manufacturers

LEACH, SHERBURNE, DEAN,  
HOUSTON, "SHR" and CURTIS SANDERS

#### THE ROBERT W. HUNT & CO.

Bureau of Inspection, Tests and Consultation,  
1137 THE ROOKERY, CHICAGO.

66 Broadway, New York.

Park Building, Pittsburg.

31 Norfolk House, London, Eng.

Inspection of Steel Rails, Splice Bars, Railroad Cars, Wheels, Axles, etc. CHEMICAL LABORATORY—Analysis of Ores, Iron, Steel, Oils, Water, etc. PHYSICAL LABORATORY—Test of Metals, Drop and Pulling Test of Couplers, Draw Bars, etc.

Efficiency Tests of Boilers, Engines and Locomotives.



**THE TANITE CO.**  
**seeks the support of**  
**Railroaders because:**

The man who uses a TANITE wheel will find it safe. Because pay for a TANITE wheel secures the greatest productive capacity. Because TANITE MILLS EMERY is mined in America and appeals to all who earn wages in America. Because TANITE grinding machines are practical.

THE TANITE CO. sells Emery, Solid Emery Wheels, Buffing Lathes, Guide Bar Grinders, Car Brass Grinders, Bench and Column Grinders, Surfacing Machines, Open Side Emery Planers, Saw Gummers, Automatic Planer Knife Grinders, Diamond Tools, Polishing Paste for Brass and Nickel, Emery Wheel Cutters and Dressers.

*The Tanite Co. builds special machines for special wants*

**THE TANITE CO.**  
**STROUDSBURG, PA**

**THE UNION**  
**SWITCH & SIGNAL**  
**COMPANY**

**CONSULTING**  
**AND MANUFACTURING**  
**SIGNAL ENGINEERS**

Automatic Block Signals—Electric and Electro-Pneumatic

Interlocking — Electric, Electro-Pneumatic and Mechanical

Electric Train Staff Apparatus

General Offices and Works at  
**SWISSVALE, PA.**

**DISTRICT OFFICES:**

**NEW YORK** - - - 143 Liberty Street  
**CHICAGO** - - - Monadnock Block  
**ST. LOUIS** - - - Frisco Building

**Oliver Lippincott**  
**Photographer**

20 John Street, New York

Process and Mechanical Prints

Perfect reproduction from Tracings, Black Lines, White Paper, any size, for Specifications and Estimates.

**New Band Resaw.**

Our illustration shows a new band resaw, embodying features that make it a good machine of medium capacity. The main frame is of improved design, of cast iron cored throughout. The tension applied to the saw blade is the manufacturers' knife edge straining device, which the makers say is a most sensitive and reliable appliance, giving even and uniform tension or strain upon the blade at all times, and acting instantly, thus greatly increasing the efficiency of the machine, and preventing the breakage of blades. The wheels are 42 ins. in diameter, 3 in. face, made entirely of iron and steel, the lower one made with solid web, cast hollow, causing less circulation of dust and giving greater weight and momentum, and thus controlling the motion of the upper wheel. The upper wheel has a lateral adjustment which can be made without stopping the machine, so as to cause the saw to run in its proper path on the wheel.

The feed mechanism consists of four rolls which open to receive any thickness of material up to 8 ins., and up to 24 ins. wide. The rolls are self-centering, and fitted with an improved device for quickly reducing thick lumber down to picture backing, panels, etc., as the inside feed rolls may be instantly moved to or from the saw by means of a lever placed conveniently for the operator, and gauged by a quadrant spaced in the most accurate manner, by eighths of an inch. The rolls may be tilted to an angle of 12 degrees. The speed is controlled by an improved variable friction feed. The improved anti-friction saw guide is mounted on a square guide post, so designed that it cannot get out of alignment, and it is counterweighted, thus making it easy to raise and lower.

Further information regarding the tool will be gladly given by the manufacturers, J. A. Fay & Egan Co., of Cincinnati, O.

The Flannery Bolt Company of Pittsburgh, Pa., are the makers of the Tate Flexible staybolt. Mr. B. E. Stafford, general manager of the company, has recently issued a couple of very interesting folders, one regarding installation, inspection and test, the other on the general application of these flexible stays to locomotive boilers. A million of these bolts are said to be in use on eighty-eight railroads in the United States. Illustrations are

given showing the area of firebox sheets to which these bolts have been applied. Write to the company in Pittsburgh if you would like to have a look at the folders concerning the Tate Flexible staybolts.

**Some Observations on Sound.**

By GEORGE SHERWOOD HODGINS.

Everyone knows the appearance of a bass drum, with its cylindrical wooden shell, its parchment heads, its zig-zag lacing cord and its row of leather lugs for tightening down the heads. When the drum is struck it gives forth a deep boom. Sound is only our perception of a particular kind of air disturbance; but the question arises, why is that kind of air

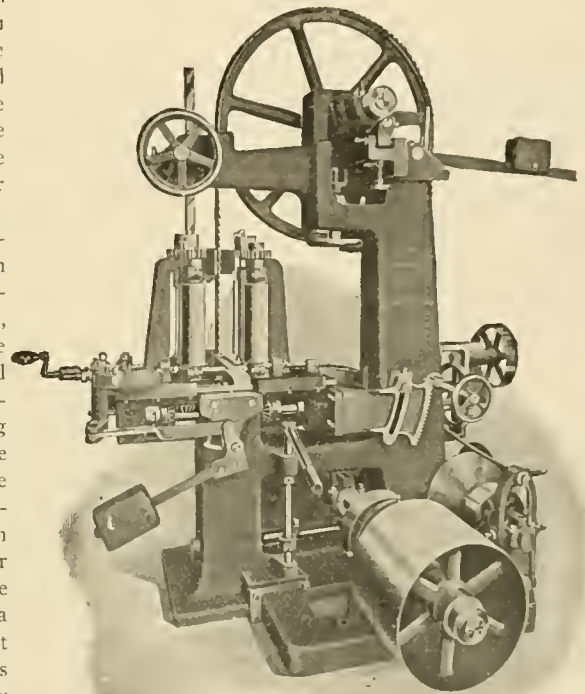

**NEW BAND RESAW.**

agitation produced when the drum is beaten?

At the moment when the drum is struck the parchment in the center of the head is carried down or in a short distance under the padded head of the drum stick by the force of the blow. After the stroke the stick is very rapidly drawn aside and the membrane swiftly springs back and bulges out almost as far beyond its normal position as the drum stick had driven it in. The whole drum head thus swings in and out several times, with the greatest movement observable at the center, and the whole eventually comes to rest.

The alternate inward movement and outward bulge is termed a vibration and at each vibration the layer of air on each side of the drum head is swept in and out, while the vibrations last. The sudden outward bulge of the drum head

heaps together the particles of air in the thin layer which rests upon it. The inward sweep causes a momentary dragging apart of the air particles behind the heaped up layer. This heaping up and dragging apart of the air, this production of alternate density and rarity, forms an air wave, like one with crests and hollow and this wave moves outward and away from the drum, in all directions, just as the circling ripples on a pond do when a stone is thrown into the water.

Looking at the drum once more we perceive that it is simply an instrument by which a series of vibrations can be produced, and these form wave-like impulses in the air. The rapid sweeping in and out of the circular drum head is all that is necessary, and the stroke from the drum stick is by no means essential. It is, in fact, quite possible to make the head vibrate without striking it at all. The motion of the air particles, alternately dense and rare, as the drum head swings out and in, may in thought be followed in their wave-like motion as they fall upon a similar drum at the other end of the room.

It should be here remarked that the particles of air themselves, although agitated by the tremor of the drum head, do not travel from one end of the room to the other. The peculiarity of wave motion is that the displacement of each air particle, though small, is made to act upon the one next to it. If the first of a row of nine pins be knocked down, and in its fall upsets the second, the second will throw down the third, and so on, until the last one, standing far beyond the reach of the first, has been overturned as the result of the series of separate knocks transmitted along the line. The motion of the nine pins would be more like what takes place in the air, if each individual in the row could recover itself as soon as it had struck the next one in the series.

We have the drum at the far end of the room, with parchment stretched and motionless. Now, as the wave-like impulse from the first drum reaches it and heaps up the air particles resting upon its surface, the membrane yields, as that of the first drum did to the stroke of the drum stick, and having yielded, it springs back quickly into the hollow of the wave. This action goes on while impulse succeeds impulse and the second drum vibrates as did the first. In both these instances the drum heads were made to vibrate, one by a stroke from a stick, the other by the alternate beat and pause of the air wave, and this is called sympathetic vibration.

Let us advance our reasoning a step further and suppose that the drum head alone, without the shell and cord, was held like a tambourine in the hand, and that instead of being made of parchment it was composed of a thin sheet of iron,

and that a magnet was suddenly placed behind the center of the disc and as suddenly removed. On the approach of the magnet the metal disc would bend toward it, as the first drum head has swung in under the stroke or as the second had yielded to the impulse of the air. When the magnet disappeared, the metal plate would spring out again, as the membrane had done, and the wave-like motion would again travel through the air.

The alternate approach and withdrawal of the magnet is, therefore, competent to produce vibration of the iron disc, but the result could be more readily accomplished in another way. Let the movable magnet be replaced by a stationary coil of wire, with a soft iron core in the centre set in position behind the disc. Through this coil an electric current can be made to flow. The current would at once cause the core to become magnetic and the disc would be attracted and incline itself toward the coil. The cessation of current-flow in the wire would de-magnetize the coil, and the released disc of iron would spring outward with the twang of a tense bow-string.

When an electric current is used, so rapidly can the magnetic and non-magnetic states be produced, and the attracting power of coil and core can be so swiftly and finely varied that the metal disc can be made to hum like the lower strings of a piano, or sing in unison with its higher notes. Substitute now, for this crude imagery, a metal disc about the size of a watch glass, held in a hard rubber tube which the hand may grasp, and in which the pole pieces of a small electro-magnet are encased, and for all practical purposes the general principle of the telephone is before you.

In dealing with these impulses which pass through the air, and in contemplating the sympathetic vibrations of the second drum, after the first had been struck, we had assumed for the moment that sound was musical. The broad distinction between musical sound and noise is that musical tone is produced by a series of regular, periodic vibrations and that noise is the result of more or less irregular shocks. The production of a musical note is secured when the impulses which travel through the air succeed each other regularly in the same definite interval of time. The origin of the periodic air waves has nothing to do with the fact that the sound is musical. The middle C of the piano is a musical note produced by 256 vibrations in each second, and this fundamental tone will be sounded, whether the requisite number of vibrations be produced by the sweep of a bow across the strings of a violin or by the blade of a knife drawn quickly over the teeth of a saw. The octave of this note is produced by the continuous repetition of twice as many, or 512 vibrations in a second, and like

## One Year and Eleven Months' SERVICE

WITHOUT REPACKING, ON

### High-Pressure Locomotives

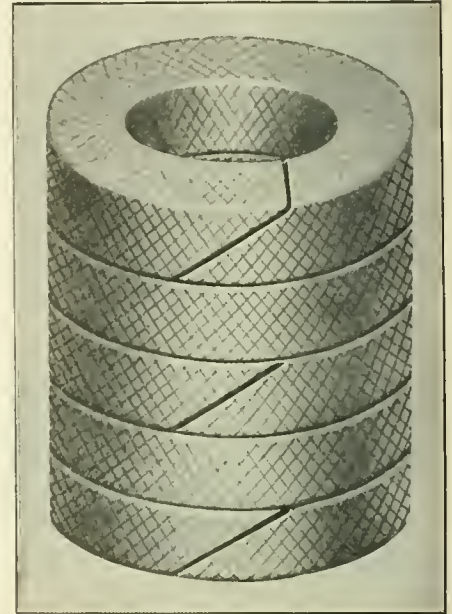

Style 300 TV.

A throttle failure is an absolute impossibility where Crandall's Throttle Valve packing is used.

IT WILL NOT BLOW OUT

## Crandall Packing Co.

FACTORY AND GENERAL OFFICE

PALMYRA, - - NEW YORK

BRANCHES

New York  
136 Liberty St.

Cleveland  
9 So. Water St.

Chicago

52 West Washington St.

## Directory of Railways of the World

The Universal Directory of Railway Officials, published in London, contains a list of the entire railroads of the world, with physical particulars and names of all officials.

Send Your Order Now

for the 1906 edition.

Price \$3.00 Prepaid

A. FENTON WALKER

Sole Representative for U. S.

143 Liberty St. New York

## Locomotive Blow-Off Plug Valves

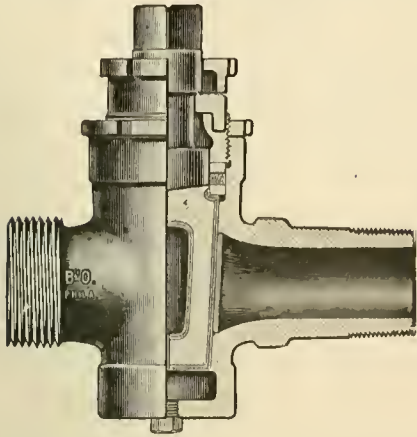
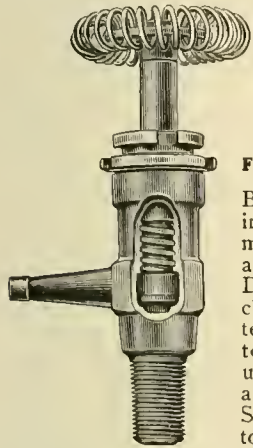

Fig. 9.

All Brass, extra heavy, with Cased Plug.  
For 250 lbs. pressure.  
Made with Draining Plug to prevent freezing.

## Locomotive Gauge Cocks



For High Pressure

Bordo Self-Grinding Gauge Cocks, made with renewable Hard Bronze Disc. Opened and closed with a quarter turn. Guaranteed Steam tight under the most exacting conditions. Shanks Threaded to specifications for Locomotives.

Fig. 23, with Wheel.

## Swing-Joints and Pipe Attachment



Fig. 33.

May be applied between Locomotive and Tender.  
These Swing-Joints are suitable for Steam, Gas, Air, Water or Oil.

Complete Booklet on Application  
**L. J. BORDO CO.**  
PHILADELPHIA, PA.

the middle C of the piano and indeed all other musical sounds, it is independent of the origin of the vibrations. The number of vibrations in any given period of time, determines what is called the pitch of the note, whether it be high or low, treble or bass. The greater the number of vibrations per second the shriller will be the sound.

The relative loudness or softness of the tone is caused by something quite different from the rate of vibration. It depends upon what may be called the extent of the vibration, and for the moment we may glance at our first illustration, the bass drum. If the drum head be struck sharply with the drum stick, the membrane will yield a certain amount. For the sake of example let us suppose that it is driven in half an inch by the

vibrations, yet the sensation produced by the vibrations of a violin string or the sweep of a knife blade over the teeth of a saw, would be very different indeed, even if the same note was sounded in each case and each had the same intensity. This difference is what constitutes the quality of a musical sound, and it is the perception of this difference which enables us to distinguish a note when struck on a piano, or the same note sounded from an organ pipe, or blown on a cornet.

The quality of a musical tone is produced by the presence of other vibrations beside that of the fundamental note. A stretched string, when made to vibrate as a whole, that is when fixed at each end like a bow string, and swinging freely on those two points, gives out a certain



DELAWARE RIVER NEAR MAUCH CHUNK ON THE LEHIGH VALLEY.

stick, and that it springs back and bulges out beyond its normal position another half inch. The membrane, therefore, at its center swings in and out through one inch of space, and this distance is called the extent or amplitude of vibration. The sound thus produced has a certain degree of loudness. If, however, the inward and outward motions had together been only half an inch, the amplitude of the last series of vibrations would be just half that of the first, the latter sound would be much softer than the former. It would, in fact, be only half as loud. If we had in the first case produced sonorous vibrations at the rate of 64 to the second, each having considerable amplitude, we should have heard a loud bass musical note.

Although the degree of loudness and the pitch of a musical tone are both independent of the origin or cause of the

musical note, dependent on the rate of vibration. The string, however, cannot be vibrated for the production of a musical note without at the same time dividing itself into segments. Superimposed on the vibration of the string as a whole are the vibrations of its equal parts. A string three feet long may be made to vibrate as a whole, but at the same time the two halves may vibrate as if they were separate strings, each 18 ins. long, or it may be that three sub-divisions will form, each 12 ins. long, and each foot of length vibrating as so many separate strings. Other sub-divisions of the string may be made to vibrate at the same time that the string is vibrating as a whole, according to where the string has been struck or plucked. It is not possible to make the string vibrate as a whole in producing a musical tone without at the same time causing some system of sub-

This illustration shows the form of construction of the

## Dart Patent Union

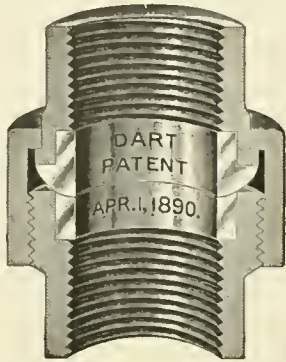

Every feature of construction represents the best points to insure stability and durability. The malleable iron pipe ends and nuts, in combination with bronze metal seats, are as near perfection as is possible to approach, and the sales to date indicate the public approval. There are none so good. For sale by all the principal jobbers in United States, Canada and Europe.

**E. M. Dart Mfg. Co., Providence, R. I.**  
FAIRBANKS CO., SALES AGENTS.

**MICA**  
CABOOSE LAMP CHIMNEYS  
Save 50 per cent.

STORRS MICA CO.,  
R. R. Dept. Owego, N. Y.



## The Twentieth Century Master Mechanic

Won't use Solid Mandrels.  
Cost too much, take up too much  
room and don't give satisfaction.

### Nicholson Expanding Mandrels

Take everything from 1 to 7 inch  
holes. Take up little room—  
always ready and you can buy  
four sets for the cost of one of  
the solid kind.

### Are You Using Them?

Catalogue tells you  
more about them.

**W. H. Nicholson & Co.**  
Wilkesbarre, Pa.

division to appear, each subdivision being always an aliquot part of the total length of the string.

A string vibrating as a whole so as to sound its fundamental note, and at the same time divided into two vibrating segments, will also sound the octave of the fundamental tone, and this tone of higher pitch, superimposed on the vibrations of the whole string, is called an overtone or harmonic partial. Not only do piano strings, but all musical instruments, emit more or less powerful overtones, in addition to the fundamental notes which they naturally give out. It is to the presence of these overtones or partials that the quality of any musical sound is due. The flute has perhaps two somewhat feeble overtones as well as the fundamental tones which it sounds, while the number of overtones which flow from a violin are as many as eighteen or twenty.

These differences are characteristic of the instruments, and no amount of skill in playing the flute will give it the fullness or the rich beauty of the violin tone, on account of the flute's inherent deficiency in harmonics. So it is with the organs of the human voice, which form the most delicately responsive, reed-like musical instrument in the world. It is to the peculiar harmonic vibrations produced by reason of the structural formation of the so-called vocal cords and to the marvelous muscular adjustments of the resonant cavity of the mouth that the human voice is endowed with that quality by which we identify each one who speaks or sings. While we associate with the voices of those most dear to us the charm of the personality we know so well, we are nevertheless indebted to the subtle sweetness of the many blended overtones, which necessarily accompany every utterance, for the pleasurable sensation produced by the sound of a voice that we love.

We are accustomed to say that if we speak into a telephone transmitter, at the end of a line wire, a friend can hear our voice at the other end. That which passes to him is not our voice, it is not even a sound wave. The sonorous impulses in the air produced by the vibrations of our vocal cords reach the soft iron diaphragm of the telephone transmitter in front of us. This diaphragm vibrates in unison with these sound impulses, which we force upon it. The fundamental notes are repeated, and the overtones of the voice are also faithfully reproduced, while the resulting shiver of the little metal plate produces, not sound, but only a fluctuation in a current, or rather a modified wave of electrical energy which traverses the wire with the speed of light, and causes the diaphragm of the receiving telephone to copy, with practically absolute fidelity, the purely mechanical motions of the transmitter, which had been agitated by the sounds

which fell from our lips. The listener, therefore, does not hear our voice. His ears are filled with an electrically produced but marvelously exact copy of it, as the new-born vibratory impulses in the air pass outward from the metal disc held but a few inches from his ear. It does not require an undue stretch of the imagination to perceive that if we were able to dispense with the voice-action of the speaker but were able to compel a similarly modified electric current to flow through the wire, we could counterfeit speech, though there had been no human articulation.

### Mogul Type Freight Locomotives.

A pamphlet recently issued by the American Locomotive Company is the seventh of the series which is being published by this company to include the various standard types of locomotives. As the title indicates, this pamphlet is devoted to the Mogul Type of Locomotive and illustrates and describes 25 different designs of 2-6-0 engines built for various railroads. The designs illustrated range in weight from 49,000 to 187,000 lbs., with hauling capacities adapted to a variety of road and service conditions, and the pamphlet as a whole constitutes a very complete record of the production of the company in this type of locomotive. Those interested should apply direct to the American Locomotive Company.

The National-Acme Manufacturing Company had hoped to be able to exhibit one of their 2¼ in. Acme Automatics at the railroad conventions at Atlantic City this month, but found that they could not do so, owing to the fact that the increasing "repeat" of former orders and new business made it impossible to arrange to have a machine available without robbing some already promised shipment. This condition is, in one sense, to be regretted, because visiting railroad and mechanical men, unacquainted with the possibilities of these tools, would have been much interested in an operating demonstration of what can be accomplished through the use of Acme Automatics. The condition is satisfactory, however, from another point of view, as it proves that the company are very busy. Write to them at their New York office, 95 Liberty street, if you desire information concerning their multiple spindle automatic screw machine.

The Ohio Valley Finance Company, which is building an electric railroad from East Liverpool to Steubenville, Ohio, has concluded a contract with the Westinghouse Companies for the power house equipment that will operate the road.

**STANDARD MECHANICAL BOOKS**  
**FOR ROAD AND SHOP MEN**  
**BY CHAS. McSHANE.**

**The Locomotive Up to Date**

Price, \$2.50

**New York and  
 Westinghouse Air Brakes**

Price, \$1.50

**One Thousand Pointers for  
 Machinists and Engineers**

Price, \$1.50

All books bound in fine cloth.

AGENTS WANTED everywhere; write for terms and descriptive circulars. Will be sent prepaid to any address upon receipt of price.

**GRIFFIN & WINTERS**

171 La Salle Street, CHICAGO

**TOOL  
 STEEL**

**Die Blocks  
 Steel Forgings**

First Prize awarded at the Louisiana Purchase Exposition, at St. Louis, for our TOOL STEEL when placed in competition with the best makes in England and Germany.

Write for Information and Prices.  
 Specify McInnes Tool Steel when ordering.

**McINNES  
 STEEL CO.**

CORRY, PA.

**Boiler Makers' Association.**

The amalgamation of the International Railway Master Boilermakers' Association and the Master Steam Boiler Makers' Association, has resulted in the formation of one society. The name of this new organization is International Master Boiler Makers' Association. Detroit was chosen as next meeting place, and following officers have been elected: President, George Wagstaff, supervisor of boilers, New York Central Railroad, Buffalo, N. Y.; first vice president, E. S. Fitzsimmons, general foreman boiler maker, Erie Railroad, Meadville, Pa.; second vice president, E. J. Hennessey, general foreman boiler maker, New York Central Railroad, Depew, N. Y.; third vice president, Wm. Wilson, general boiler inspector, Illinois Central Railroad, Chicago, Ill.; fourth vice president, E. W. Rogers, foreman boiler maker, American Locomotive Company, Paterson, N. J.; fifth vice president, Peter F. Flavin, Standard Railway Equipment Company, Bloomington, Ill.; secretary, Harry D. Vought, New York City; treasurer, Frank Grey, foreman boiler maker, Chicago & Alton Railroad, Bloomington, Ill.

The San Francisco office of the General Electric Company is now permanently located in the Union Trust Building in San Francisco. Since the fire the office has been located in the Union Savings Bank Building at Oakland, Cal., large temporary warehouses having also been erected in the same city.

Not long ago the Chicago City Railways Company purchased from the General Electric Company, 1,200 direct current railway motors with controlling apparatus for the operation of 300 new cars. Power for the new rolling stock will be supplied by additional electrical generating machinery aggregating 6,000 horsepower. Each car will be equipped with four 40 horsepower motors, this size of motor being the standard for urban railways.

List No. 13 of second-hand metal-working machinery has just been got out by the Niles-Bement-Pond Company, of New York. It of course includes railroad machinery, and after this general head follow screw-cutting lathes, speed lathes, lathes not screw cutting, brass finishers' lathes, chucking machines, turret-head plain and wire-fed screw machines, planers, shapers, drills, cutting off and centering machines, tapping machines, milling machines, boring machines, punches, shears, grinding and polishing machines, blowers, forges, wood-working machinery, etc., etc. There are in all 294 machines catalogued, so that those who are on the lookout for

this kind of equipment have a large assortment to choose from.

**Stood Severe Test.**

This cold spring weather was indirectly the means of providing a very interesting and instructive test concerning the storage of illuminating gas on railway cars, and the way that it all came about was this.

The D., L. & W. are driving a tunnel through the Bergen hill near Hoboken, N. J., and this new tunnel is very close to the one they now use for regular traffic. So close is the new work to the old tunnel that great watchfulness has to be exercised for fear that some rock might be jarred off of the existing tunnel roof and fall on the track over which regular trains run. The D., L. & W. therefore fitted up a special inspection car which was equipped with an acetylene projecting lamp and three of the Commercial Acetylene Company's safety storage gas tanks to supply this lamp. This car was run through the regular tunnel after every blast in the new work, and the light is thrown upon the roof of the existing tunnel to see that everything is all right.

The inspection car was coupled to an ordinary caboose, and in shifting it about the yard, this inspection train received a severe bump against the stop block. The caboose had a coal fire in its stove on account of the cold weather, and the bump against the stop block upset the stove and the car at once took fire. It was completely burned and so was the inspection car equipped with the safety storage gas tanks containing acetylene. The fuse plugs melted in two of the tanks and thus liberated the gas without explosion. In the other tank the fuse did not melt and the evidence seems to show that the piping from this tank became white hot and it is believed that the gas burned, but there was no explosion from the tank and the flame did not flash back into the tank on account of the asbestos filling with which these tanks are packed. The tanks which stood this extraordinary test will be shown at the Commercial Acetylene Company's exhibit on the Steel Pier at the Railroad Conventions in Atlantic City, this month.

**Engine as a Telegraph Instrument.**

When Thomas A. Edison was a boy he was an expert telegraph operator, and had a rather unusual chance to display his ability with the Morse code while living in Port Huron, Mich. There was a telegraph cable connecting Port Huron with the Canadian town of Sarnia. It was about the end of a very hard winter, and the ice shove on the river had broken the cable connecting these points, and telegraphic communication was therefore cut off. It occurred to young Edison that he could institute a temporary means

*Perfect*

Why pay more for a Car and Locomotive Cleaner, when the "PER-FECT" will do the work and better at 48 cents per gallon, f. o. b. Philadelphia or Chicago?

THE MODOC SOAP CO.  
228 North Fourth Street  
PHILADELPHIA, PA.

**Fifth Edition,  
Revised and Enlarged**

Number of pages increased  
from 617 to 946, and figures  
from 309 to 494.

**Price, \$3.50**

**LOCOMOTIVES:**  
**SIMPLE,**  
**COMPOUND,**  
**AND**  
**ELECTRIC**

By **H. C. REAGAN**, Electrical Engineer

Send for  
Descriptive Circular

**JOHN WILEY & SONS**  
43 and 45 E. 19th St.  
NEW YORK CITY

**Oil Burning in Locomotives**

Is described in our new book  
Care of Locomotive Boilers,

50c. - - This Office

of communication between the two sides of the river, which is here more than a mile wide. He went to the railway yard at Port Huron and made his wants known, and was allowed to get on a locomotive engine standing in the yard. He blew the whistle so as to emit a series of short and long sounds in accordance with the Morse telegraphic alphabet. What he made the whistle say was, "Sarnia! Sarnia! Sarnia! Do you know what I say?" At first there was no answer. Edison kept this up again and again until some one on the Canadian side was struck with the evident intention and purpose of the repeated whistles. Soon an answer came back from a Sarnia engine, and thus communication between the two sides of the river was temporarily resumed. Being thus able to communicate, those engaged on the work were able to concentrate their effort to the readjustment of telegraphic communication. Mr. Edison himself vouches for the correctness of this incident.

Among orders recently received by the Bliss Electric Car Lighting Company, of Milwaukee, is one from the Baltimore & Ohio Railroad to electrically light the Royal Blue Limited trains with the Bliss system of electric car lighting.

**CONTENTS**

Air Brake Department.....	261
Boiler Makers' Convention.....	272
Book Notices .....	255
British Board of Trade, by A. R. Bell.....	239
Cars:	
* Boston Elevated Side Door.....	242
* New Mail Vans, S. E. & C. Ry.....	250
* Correspondence School.....	257
* Cowlairs Incline at Glasgow.....	278
* Cushioned Non-Return Valve.....	286
Editorials:	
Am I My Brother's Keeper?.....	252
Apprentice Instructors .....	254
British Board of Trade.....	252
Inland Traffic by Water and Rail.....	255
Limitations of Smoke Prevention.....	253
New Northwest Passage.....	255
Present Status of the Compound.....	254
* Electrical Department.....	263
Engine as a Telegraph Instrument.....	297
Gasoline Engines in Railway Work.....	287
* General Correspondence .....	245
General Foremen's Association.....	279
* Grease Moulder.....	256
* Great Northern Motor Car.....	289
Hints on Brazing.....	242
Illinois Traction System Opening.....	292
* Items of Personal Interest.....	269
Locomotives:	
* Atlantic Coast Line 4-6-0.....	277
* C. & N. W. Ten-Wheeler.....	251
* Italian Compound, 4-6-0.....	287
* Southern Pacific, Atlantic.....	244
* T., H. & B. Ten-Wheeler.....	260
* Locomotive Blow-off Valve.....	288
* Locomotive Testing Plant.....	274
Mechanical Engineers' Meeting.....	290
Merchant Bar Iron.....	268
* New Band Resaw.....	203
Officers of Boiler Makers' Association.....	297
* Patent Office Department.....	273
* Phillips Automatic Train Control.....	266
* Pipe Threading Machine.....	201
Problems in Railway Signaling.....	281
Quaint Origin of Things.....	276
Questions Answered .....	258
Rail Breakages .....	292
* Shaw Cranes for Panama.....	283
Shop Betterment .....	285
Some Observations on Sound, by G. S. H.....	293
Speed and Safety.....	288
* Tuhular Bridges .....	237

**A**  
practical  
demonstration  
of the  
advantages  
of the  
**BLISS**  
**SYSTEM**  
of  
**ELECTRIC**  
**CAR**  
**LIGHTING**  
will be  
given at  
**ATLANTIC**  
**CITY**

During Convention Week (June 12th to 19th) we shall be glad to have all interested in the subject of electric car lighting visit our exhibit on the Steel Pier—Spaces 1,201 to 1,207, inclusive. We shall have there complete Bliss car lighting equipments operating under actual service conditions.

Each separate part of our equipments will also be exhibited in detail, affording railroad men an opportunity to acquaint themselves with the construction and operation of the best system of axle lighting yet devised.

The following representatives of our Company will be on hand to welcome visitors and to explain to them the operation of the Bliss System:

W. L. BLISS,  
JOHN L. BLISS,  
COL. JNO. T. DICKINSON,  
WM. L. LALOR,  
ROBERT C. SCHALL,  
F. URBAN,  
E. B. H. TOWER, JR.

**Bliss Electric Car Lighting Co.**  
Main Office and Works, MILWAUKEE

New York Office:  
NIGHT AND DAY BANK BLDG.  
Chicago Office:  
MONADNOCK BLOCK.

*Those who are not going to the Convention should send for a copy of our Bulletin 30, which is the next best way of becoming acquainted with the merits of the Bliss System.*

# Railway and Locomotive Engineering

Copyright by Angus Sinclair Co.—1907

A Practical Journal of Railway Motive Power and Rolling Stock

Vol. XX.

136 Liberty Street, New York, July, 1907

No. 7

## The Modern Mountaineer.

Mountain worship was one of the oldest phases in the mental development of mankind. Veneration of the lofty and the terrible as embodied in the massive mountain chains has always been, as it were, native in man's nature. At the

has been a passion, and the glorious mountains of Switzerland have been the scene of many an adventurous attempt to scale the snow-capped heights, to enjoy the enchanting visions there unfolded and to breathe the rarefied atmosphere of those lofty regions above the clouds.

veil. Up this mighty mountain and into the regions of eternal snow, an electric railway has been built, with rack rail in the centre, on each side of which the driving pinions of the motor engage. The gauge of this road is 3 ft. 4 ins., and its length is about 3 miles. This rail-

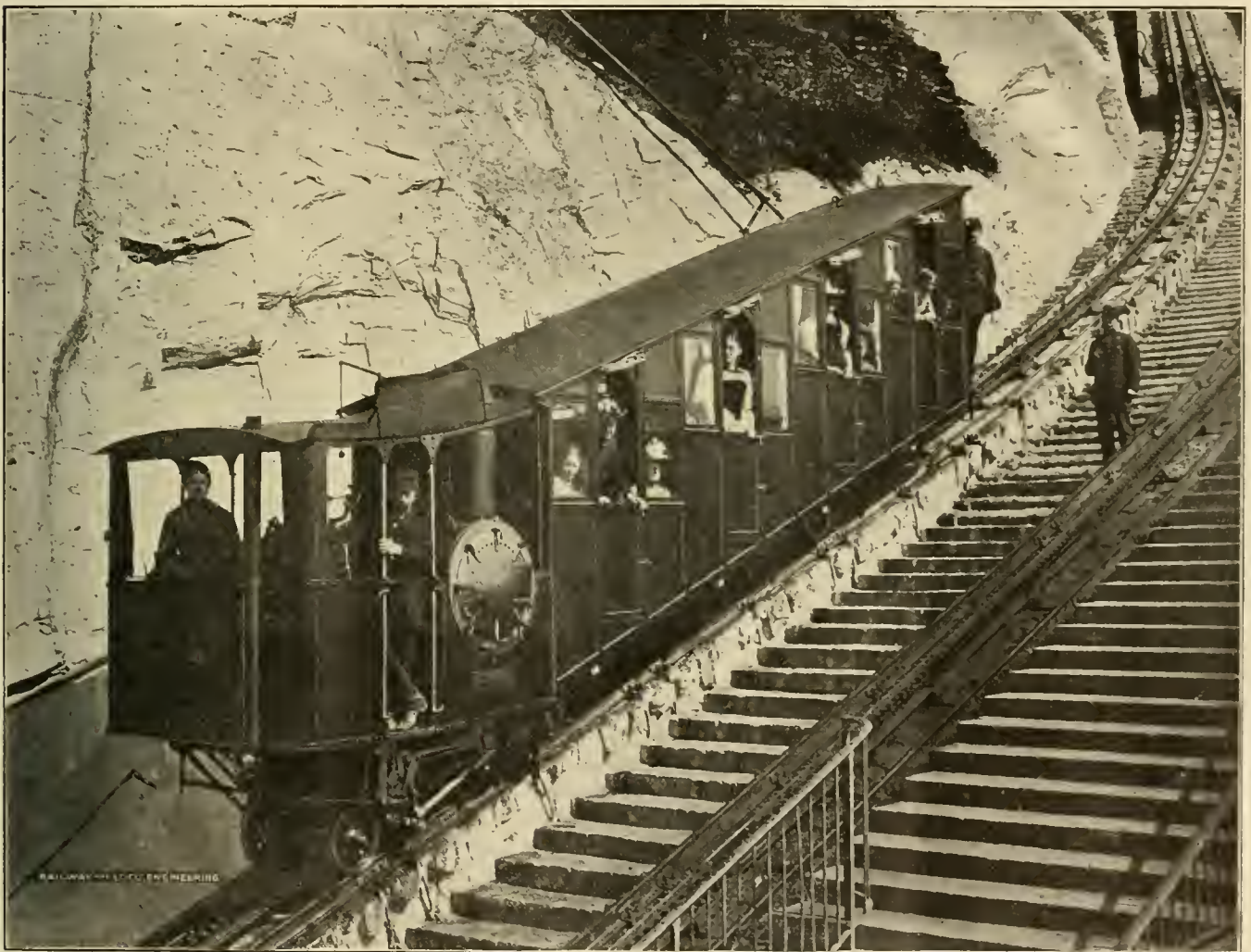

TYPE OF CAR TO BE USED ON THE MATTERHORN RAILWAY.

base of the highest range in the world dwelt the primitive Hindoos. Their oldest songs tell us of the pious fervor with which they chanted the praises of their "eighty-four thousand mountains of gold."

Mountain climbing has, in modern days, been more than a mere pastime; it

One of the most conspicuous mountains of Switzerland in what is known as the Bernese Alps is the famous Jungfrau, rising to a height of 13,600 ft. above the level of the sea. The name of this mountain was derived from the dazzling whiteness of its snowy mantle, which suggests in its unbroken purity a maiden's bridal

way comes up from Schiedegg, passing through a tunnel 275 ft. long to the edge of the Elger glacier. From here on it skirts the cliffs and enters the Jungfrau tunnel, and at last with many glimpses through cuttings along the road reaches a point 10,365 ft. above the level of the sea.

The Matterhorn Railway, yet to be completed, is a more daring engineering feat. This imposing mountain, the Matterhorn, called also Mount Crévin, is in the Pennine Alps. It attains an altitude of 14,780 ft. above the sea. The name Pennine is given to the division of the Alps which includes Mount Blanc and Monte Rosa, and which from the

by an electric railroad which has the reputation of being the highest in Europe. With an ascent of 1,500 ft. more this railroad scales the famous eminence of the Gorner Grat, the culminating summit ridge at the edge of the Riffelberg.

"The first climbing of the mountains around Zermatt made some of the greatest achievements of the Alpine explorers

type of steam car which will be used on the lower slopes of the Matterhorn railway. One end of the car is occupied by the engines and boiler, the driving mechanism being pinions, which engage with the central rack rail. Not only is the rack and pinion used for driving, but they are also employed for applying brakes. The pinions can be retarded by the tightening of a band brake, similar to that used on hoisting engines, and the locking of the pinions by this means holds the car stationary on the steep incline. The car has been so held while the photograph was taken, from which our half-tone has been made.

According to the plans of the Swiss engineers, Unfeld and Golliez, the ascent of the Matterhorn will be made by rail from Zermatt to a point 10,000 ft. above sea level. From there the rest of the journey will be made by what is called a funicular railway, 7,700 ft. long, up a gradient of 85 per cent. This kind of a railway is one in which a cable is used to pull the car up the incline or let it down. The word comes from the Latin funis, a rope. A car moving up so steep a grade will practically be an elevator or inclined lift. The upper extremity of this road will be but 60 ft. below the actual summit of the mountain. A building forming the terminus will stand on an excavation in the solid rock, and will have windows on all sides, commanding a view of the unsurpassed panorama, from that eerie height.

The magnificence of these mountains has been the theme for poets, as well as the work ground for the man of science. Shelby and Coleridge have sung of the glistening ramparts of Mont Blanc and the beauties of the vale of Chamonix. Byron, peering down from the snow-crowned heights of the Jungfrau, exclaims, "And you, ye crags, upon whose extreme edge I stand, and on the torrent's brink, beneath behold the tall pines dwindled as to shrubs in dizziness of distance."

Tyndall, the man of science, the intrepid mountain climber, studied the works of nature in these wilds from the smiling valley to the icy peak, and has laid bare the secrets of the glacier and the avalanche. The mountains up which the daring railway engineer projects his line, discarding the Alpine stock and the ice axe for the surer rack and pinion, though the heights are covered with the eternal snows, are yet below the line where man may venture up. Above us, even here in the unbroken sunshine of the cloudless sky, there lies a region where life cannot exist and, as Reclus tells us, with all man's noble wish to conquer he is held forever back, yet into this terrible zone of death the loftiest mountains of the earth proudly elevate their hoary crests.

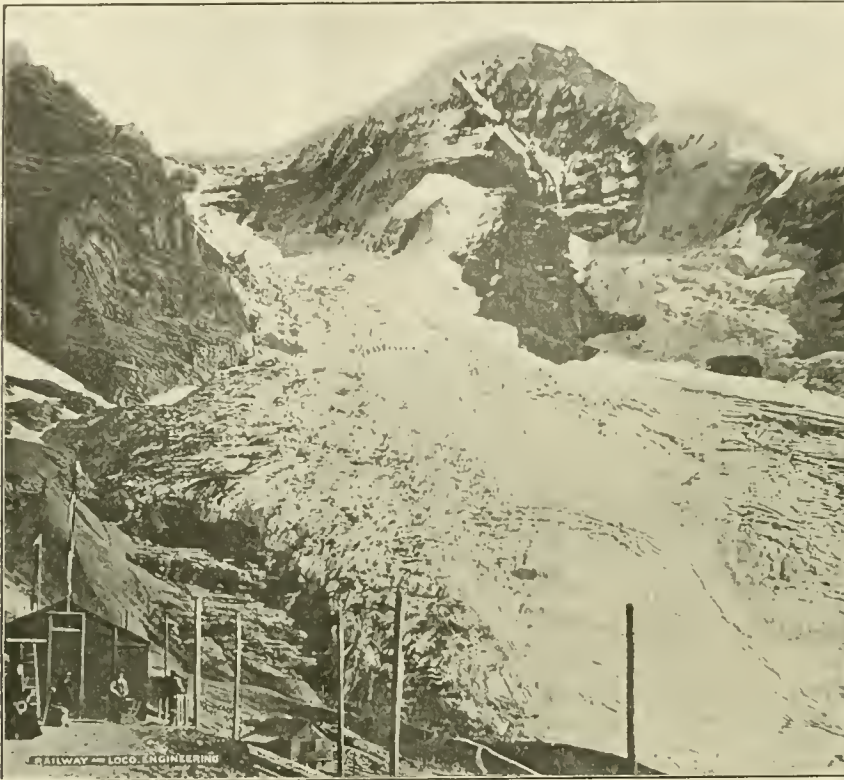

STATION ON THE JUNGFRAU WHERE THE ROAD ENTERS THE ICE REGIONS.

earliest times was recognized as the highest range in Switzerland. In fact, the word Pen is allied to Ben, a word used to indicate any conspicuous mountain. We have it in Ven Venue, Ben Ann, Ben Nevis in Scotland and elsewhere. In this connection it may be mentioned that the word Alp signifies white, and is derived from the Latin, albus. The ancient name of Britain was Albion, so called from the white chalk cliffs of Dover.

The Matterhorn has been called 'a cruel peak which stands up alone and solitary; a gigantic triangular pyramid. A writer in the *New York Times*, from which paper our mountain photographs are taken, in describing the road which, when completed, will reach an altitude of 14,700 ft., says: "As it is to-day a railroad goes up the rugged ravine formed by the Visp, a tributary to the Rhone, to the village of Zermatt, the terminus of the projected Matterhorn road. Zermatt lies in a beautiful green valley surrounded by mountain slopes fringed with pine at an elevation of 5,300 ft. Southward from Zermatt, at an elevation of 8,400 ft., is the high plateau of the Riffelberg, which is reached

during the last half of the nineteenth century. The Matterhorn, although not as high as Rosa, is considered the grandest of all these mountains. It rises a stupendous pramid above the surrounding summits and glaciers, and as seen from the Zmutt vale looks like a ponderous bastion tower at the termination of a long ascending curtain wall of rock. For precipitous steepness and solitary grandeur it is unique among the monarchs of the Alps. It is composed of sheer slabs of rock much like the slates on a roof, patched with ice and snow, and giving only the most precarious foothold to the venturesome climber. The top is an almost level ridge about 300 ft. long, and from it there is a marvelous view over mountains and glaciers in every direction, with a dip below of often over a mile in extent.

"It is the loose rock lying along the precipitous sides of the Matterhorn that has made the ascent of the latter so peculiarly dangerous to the Alpine climber, and will, no doubt, bring a decided element of difficulty in the way of the builders of the proposed railroad."

Our frontispiece this month shows the



### Steel as an Engineering Material.

By WM. STUART STANDIFORD.

Of all the materials that the engineer uses, steel is the most important. It is a metal of great antiquity, the Hindus, Persians and other ancient races making an excellent quality; the celebrated Damascus brand being the best. However, while the metal made by these people was of very fine quality, yet their methods of production were so crude and slow that the output was limited. It remained for our modern steel makers and mechanical engineers, etc., to so perfect methods and appliances that an enormous tonnage can be made and sold at reasonable prices; the result being that steel has come to be used to a great extent.

The influence that this material has on the civilized world is most remarkable, as well as beneficial. It is a grand, good metal; good in itself, better in that it has helped to place man higher above his relations in the animal kingdom. Steel is a variety of iron distinguished for the extreme and varying degrees of hardness of which it is susceptible, and for possessing at the same time the fusible property of cast iron. In composition it holds a place intermediate between wrought and cast iron. The first being nearly pure iron. Steel is iron containing from .50 to 1.50 per cent. of carbon. Cast iron contains between 4 and 5 per cent. As the proportions of carbon increase, the metal approaches cast iron in its properties, becoming hard and brittle and increasing in fusibility.

But with diminishing proportions of carbon the metal assumes more and more of the toughness of wrought iron. Steels of the former character are called "high carbon," and the latter "low carbon" steel. The most striking characteristic of this metal is the fact that it acquires a higher degree of elasticity than any other material. Another peculiarity of steel is the different degrees of hardness it assumes by changes of temperature. It is also more slow than iron to become magnetic, but once magnetized it retains this property most tenaciously.

Other ingredients besides carbon are found in it, the most common and objectionable being sulphur and phosphorus. The chief bad qualities imparted by these impurities are "red-shortness" and "cold-shortness." Steel is red short when it is brittle at a red heat; this is caused by its containing too much sulphur, which also makes it bad for welding. Cold-shortness is produced by the phosphorus in the metal, it renders the material brittle when cold, and fit for nothing but making paper weights.

The majority of the tonnage of steel to-day is furnished by the crucible, open-hearth and Bessemer processes. Crucible steel is made by taking bars of wrought iron and covering them over with charcoal or other carbonaceous substance, they are then put in an air-tight crucible and subjected to an intense heat until the bars are all covered with blisters.

These bars are then taken out and melted in a crucible. This is the very

duction of the metal is obtained by using the regenerative furnace invented by Siemens. This process of making steel consists in first melting cast iron on a layer of sand or magnesite, and then adding wrought iron to the melted cast iron; the flame then being made to pass over the mixture, the action of the flame reducing the carbon and silicon of the molten mass and producing steel. The open-hearth metal is used most extensively; for



VIEW OF THE RAILWAY UP THE JUNGFRAU. ON THE LOWER SLOPES, WITH THE SNOW-CAPPED PEAKS ABOVE.

finest steel made, but, on account of its being very expensive, it is used only in certain parts of machines, fine tools, etc.; also for making razors and cutlery. Of course it would be folly to use this steel for all parts of a machine except for parts where great endurance and sharp edges are required. Open-hearth and Bessemer processes produce metal that gives satisfaction in making wearing parts of mechanism.

By the open-hearth method the re-

making armor plate, boiler plate, guns and machinery this steel is unsurpassed, being low in price and having excellent quality. Bessemer steel (named after Sir Henry Bessemer, inventor of the process) is made by melting cast iron and wrought junk in a furnace; after the material becomes melted it is conveyed to a bottle-shaped converter, which is lined with a refractory substance.

The "converter" has connected to the

bottom a pipe, so that a blast of air can be sent through the molten mass, the blast being turned on after the melted iron is put in the converter. The oxygen of the air combining with the carbon in the iron burns the carbon entirely out, until nothing is left but wrought iron. A known quantity of carbon is then added (called *Speigeisen*) and the steel is then ready for pouring into the ingots. The making of Bessemer steel is an inspiring sight at night—a roaring flame fifteen feet or more in length surrounded by a myriad of star-shaped sparks (which is the burning carbon) being projected out of the converter for ten minutes.

This steel, while not so fine in quality as the crucible or open-hearth variety, is largely used in the arts and manufactures by the civilized nations of the world, it being found suitable

1 to 1.15 per cent. carbon being used for shear knives and lathe tools; 1.15 to 1.50 per cent. carbon is used for engraving tools, scribers, drills and lathe tools.

Open-hearth steel containing 5 per cent. of nickel being used by the governments of various nations, for making guns, armor plate and steam engines; it being found by experience that low-carbon metal containing the above percentage of nickel has all the strength of a high-carbon steel, with the advantage that the greater ductility of nickel confers. Parts of machinery can be made lighter, and thus save weight. It also makes fine tools, being 45 per cent. tougher than the ordinary tool steel. This material has been found not to corrode so quickly as the ordinary steel. There is one branch of machine work in our indus-

provide their workmen with steel too low in carbon for their lathe tools; the result being that the tool and the metal to be cut are nearly matched for hardness, the roll turner has to be continually grinding, in order to keep the tool sharp, thus wasting time and money besides producing inferior work.

Roll-turning tools have to be hardened instead of tempered like the ones machinists use, as it is necessary to hold a sharp edge. For hardening this class of tools the blacksmith heats the steel to a cherry-red color and then dips it into salt water, and it is ready for use. The writer has found out by experience that the salt can be advantageously replaced by a 5 per cent. solution of sulphuric acid—this cuts the scale and hardens the steel so as to make it superior to the salt-hardened one. During the last few years a new kind of steel has appeared, called "high-speed" steel. This is a metal that has some marvelous qualities, and it bids fair to revolutionize the output of the machinists' lathes for turning moderately hard metals. At the present time it is unsuitable for roll turners' use for chill rolls, on account of the low amount of carbon it contains; although our manufacturers later on may so perfect the quality of the material as to render it useful in turning chilled iron rolls.

As used by machinists on moderately hard metal, this steel is capable of taking very heavy cuts, at three times the speed taken by any usual brands. It being not unusual for the point of the tool to get red hot while roughing off the work, and still keeping sharp. To the ordinary metal worker this may seem incredible, but the fact remains as stated, as any person can prove for himself by visiting an up-to-date engineering works. These steels contain chromium and tungsten, which gives them the characteristics above stated. On account of the well-known oxidizing properties of iron and steel, it is the usual practice among the manufacturers of articles made from these metals to give them a coating of paint, japan, galvanize with zinc, tin or electroplate them with copper, nickel and various other metals to prevent rusting.

It has been found by experience that iron will last three times longer than steel (when they are both unprotected from oxidation), this is due no doubt to the particles of slag and other impurities in the iron, which make the process of rusting slower. Enormous quantities of sheet iron and steel are manufactured into cooking utensils, some being coated with tin, and others covered with enamel and porcelain. Despite the drawback of rusting easily, this metal is universally used in the arts and manufactures, and the output



RAILROAD SURVEYORS' CAMP. HEIGHTS YET TO SCALE.

for making structural shapes and sections for sky-scraper buildings, also parts of machinery where the use of other steels would be too expensive. As carbon is the hardening agent used in tool steels, it follows that by altering the percentage of that element we can have any degree of hardness independent of tempering. And as tools are used for different purposes it is the usual practice to have varying amounts of carbon suitable for the purpose for which each tool is to be used.

Appended is a short list showing the amounts: .50 to .60 per cent. is used for battering tools; .60 to .70 per cent. for hot work and dull edge tools; .70 to .80 per cent. is used for some forms of reamers and taps; .80 to .90 per cent. carbon used for cold chisels, drills, dies, etc.; .90 to 1 per cent. is used for axes, knives and for similar purposes;

trial problem that requires the very highest quality of metal, and that is "roll-turning." When it is seen that the iron, steel, copper and brass industries depend on this trade for the shapes and sections used by the engineering world, it will readily be seen how important it is for the roll turner to use good steel in order to do perfect work.

The hardest material that this class of workmen have to turn is "chilled iron" rolls. This metal is intensely hard, and in order to turn it and do accurate work a steel high in carbon (1.50 per cent.) is required—the tool also should contain 5 per cent. of nickel. It being a fact that the tool has to be harder than the metal it is turning, in order to do any cutting at all. Unfortunately, many employers do not seem to realize this fact, and

is increasing steadily every year. While our modern metallurgists can produce a most excellent quality of steel, yet there is one kind of metal made by the ancient Persians that has proved to be a lost art; this is the celebrated "Damascus" steel. Swords made of this metal would take an edge as keen as a razor, the blade being so flexible that it could be bent around the body in a circle, yet this same weapon, when handled by a strong arm, could cut through a small iron bar, without dulling the edge. Such were a few characteristics of this famous metal. In its chemical qualities, iron exhibits some peculiar properties; for instance, it will make bricks a red color—yet, when it is dissolved in glass, it produces a green color.

The reason why iron should make such different colors is beyond our knowledge. In conclusion, steel has benefited the civilized races, and added to the comforts and luxuries we enjoy and helped to place mankind on a higher plane of existence. In the hands of surgeons it has saved countless lives while as employed by the armies of the world it has caused untold carnage, suffering and destruction. The use of this metal for war purposes is deprecated and it will be done away with in the future, it being better to arbitrate differences than to settle them by the arbitrament of the sword.

#### Once Upon a Time.

Now that railroads have become practically part of our very life, it is hard to realize that in the early days they were actually feared. The following is an extract from an editorial published in 1835 in the *John Bull*, a London newspaper, when railroads were just coming into existence: "Does anybody mean to say that decent people—passengers who would use their own carriages and are accustomed to their own comforts—would consent to be hurled along through the air upon a railroad, from which, if a lazy school boy left a marble or a wicked one a stone they would be pitched off their track into the valley beneath; or is it to be imagined that women who may like the fun of being whirled away on a party of pleasure for an hour to see a sight would endure the fatigue and misery and danger, not only to themselves, but their children and families, of being dragged through the air at the rate of twenty miles an hour, all their lives being at the mercy of a tin pipe, or a copper boiler, or the accidental dropping of a pebble on the line of the way. We, however, go farther, and denounce the mania as destructive of the country in a thousand particulars—the whole face of the kingdom is to be tattooed with these odious deformities; huge mounds are to intersect our beautiful valleys; the noise and

stench of locomotive steam engines are to disturb the quietude of the peasant, the farmer, the gentleman, and the roaring of bullocks, the bleating of sheep, and the grunting of pigs are to keep up one continuous uproar through the night, along the lines of these most dangerous and disfiguring abominations. The loss of life upon the favorite toy from Liverpool to Manchester has already been terrific. Mr. Huskisson was the first martyr

#### Quick-witted Women.

The inhabitants in the upper part of New York City had a moving spectacle one night last month when a train rushed along with the hood over the front platform of the buffet car enveloped in flames. There were ten cars on the train, but no one on the train seemed to notice the fire. A quick-witted woman notified Police Headquarters that a train was going north



A BIT OF RACK AND PINION ROAD ON THE VERY EDGE OF THE ABYSS ALONG THE SHEER SIDE OF THE MOUNTAIN.

to this favorite absurdity, and the last splendid exhibition took place only on Thursday, on the new tom-foolery to Greenwich, when in the outset, 'by some accident,' one of the carriages, in which a party of noodles ventured themselves, was thrown off the rail, but, although it ran avast many yards, no serious accident occurred. How lucky! Nobody killed the first day of the trial."

Never jump at a conclusion—it might knock you down!

in a sheet of fire. The electric wires were kept buzzing and when the fiery chariot, otherwise the burning train, reached 125th street, the Fire Department was on hand. The passengers hurriedly left the cars and seemed to enjoy the show. The firemen quenched the flames in nine minutes. The name of the quick-witted woman is unknown. She did not see the firemen at work, for the train had passed far beyond where she was, but the result of her efforts was highly satisfactory to all concerned.

# General Foremen's Association

## Individual Effort.

The report on Topic No. 3, the Individual Effort System, was presented to the General Foremen's Association at the recent annual meeting by Mr. D. E. Barton, general foreman of the locomotive department of the Atchison, Topeka & Santa Fe, at Topeka, Kan.

He said, "Very few men realize, unless they are actually deep in the game, the difference between a bright, active, energetic, keen, industrious workman, and one who is only looking for a half satisfactory finish of the day's drudgery, and a release from its thralldom. When comparisons (which are said to be odious) are made between the two, and the results are weighed and multiplied by the number of minutes, hours, days, years, and by the number of men, using their energy on the same lines, one is fairly staggered by the showing. To a man who is interested, who is not only paid to take such interest, but who is in the game for his daily bread, and whose honor and well being are at stake, the picture thrown on the canvas makes him sit up and take notice.

"To a man who is held responsible for the actions of his fellow workmen, and made to feel the weight of just criticism for their actions, there is a most intense desire to see some automatic device invented to change the men in his charge, from half hearted, listless, idle, indifferent workmen, to striving, alert, active, intelligent, honest, self-respecting workers who intend to and do take an intense interest in the work at hand, and are willing to do 'whatsoever their hands find to do with all their might.' Feelings, not of slavery; not of drudgery; not of mere repetition; not of copying and imitation, but of improvement; of deep thought, of how and when to bear down, and when to ease up; of how and when to cut, and when and where to smooth and finish, this should animate every worker. There are few men who are more interested in the efficiency of workmen than the members of the International Railway General Foremen's Association.

"To those who have realized that their employers were being 'held up' by some of the men in their charge, and also that they were powerless to stop it, and equally powerless to secure proper compensation for the worthy workmen who were practically carry-

ing the drones on their backs, the very knowledge of the fact that there was a method, an almost automatic system, which while it does not convert a dolt into a genius, nevertheless brings out the good qualities of men, and produces a tone, an efficiency, a state of progress, in fact brings results, should and does cause the thinking foreman to reach out for it and welcome it, especially since it enables him to give proper attention to other pressing matters, for which under former conditions he had scant time.

"Such a method is found in the 'Individual Effort System' which is now in operation on one of the great railroad systems, and while not in operation long enough to place it above the adverse criticism of men who have not studied it, nevertheless is so well founded on just laws, appeals so strongly to business principles, that it will never be set aside by a return to the older methods, but it will progress in some modified form as greater experience evolves improvements, until it becomes universal.

"The Individual Effort System differs fundamentally from piece-work in that it is distinctively co-operative and, therefore, especially adapted to shops where the quantity and quality of the output must depend on favorable surroundings, methods, machines, and general equipment, provided by the employer, combined with intelligent, reasonable and faithful interest, and effort on the part of the worker. It is based on the full understanding that reductions in cost due to the improvement of the plant properly belong to the employer, but that any reduction in the time, below a reasonable standard, shall belong unassailably to the worker who effects it.

"The worker is in any case assured of his day rate, and that is right, since he is powerless to prevent many delays. If a reasonable standard time is four hours, a bonus payment for time reduction begins at six hours, and gradually increases, until at four hours the worker is paid an increase of 20 per cent. If the worker goes below four hours he is given all the increase due to his own reduction; if he does the work in two hours he receives four hours' pay.

"What is a reasonable standard time? A reasonable standard time is one under which a good worker (in response

to a stimulus of 20 per cent increase of pay) will make steadily, without undue exertion, month in and month out. No one compels him to realize standard time, as, however, his failure to realize it causes great loss to his employer, and causes a loss to the foreman, both become interested in ascertaining the cause of the inability to make standard time. It must lie either in the conditions or in the man; if in the conditions it is the employer's business to better them, if in the man his troubles should be investigated, and he should be encouraged to do better.

"A striking instance of this kind occurred recently at Topeka. The standard time for a certain job was three hours. The man on the job, a good man, took nearly twenty hours. This immediately caused an investigation which showed that the steel castings were abnormally hard. Annealing was tried, and other remedies, but in vain. So for that particular lot of castings, the schedule was lengthened to twenty hours, and made to apply backward, and cover all the work done during the period of trouble.

"The individual effort is co-operative, because either of the partners can at any time drop back to day-work if he does not like the conditions. The employer, through the foreman, may say: 'This work requires unusual care, take all the time needed and do it right.' It is not scheduled. The worker receives his day rate. Or the other worker may say: 'This schedule is unsatisfactory; it is too low; the machine is out of order. I shall not fret about standard time, but work as best I can; I am at least sure of day rate.'

"The Individual Effort System also stimulates the judgment of the foreman in selecting the proper man for the work in question, the proper machine, and in cases where work has not been standardized, the preliminary estimate of suitable time can be safely left to the foreman. If he estimates too long a time and the worker beats it, the poor judgment of the foreman is shown up. If he estimates too short a time, and the worker takes longer, the foreman's poor judgment is again shown up. If he enters into a deal with the worker and tells him he is to take six hours on a six hour estimate the worker receives standard pay only and is not benefited, while a time study of the operation may at any time reveal

the dishonesty of both foreman and worker. The opposition of the future to this system will be more likely to come from certain employers than from the men; from those employers who fail to realize that the best workers are, in proportion to what they receive, the most economical workers; from those employers who fasten their attention on the rate a man receives, rather than on the cost of the work turned out by the best men; from those employers who do not know that costly equipment of new machinery can not, as a rule, effect the same economies of production as the interested and efficient combined efforts of employer and employe.

There is no better way of economizing in fixed charges, which are a detriment to both worker and owner, than to increase output. There is no better way to increase output than to secure the confidence, and enlist the co-operation of the worker by allowing him to increase indefinitely his own pay through his own efforts. Mr. Harrington Emerson, now Standardizing Engineer of the American Locomotive Company, with the able help of many practical assistants, and with the advice and co-operation of the foremen, of the officials and of the Superintendent of Shops at Topeka has developed this Individual System. When he first came to the Santa Fe, his methods were received with doubt by those in charge, and with distrust by the workers. The system now has the confidence of both shop officials and workers where it has worked for shop betterment, helped out the foremen where they most needed help and given to each worker a larger independence and manhood.

The outline of its introduction is as follows: With and through the co-operation and advice of the Superintendent of Shops and his assistants, a general betterment of conditions was undertaken. Shafting and machinery were lined up and also speeded up. Motors changed so as to be better adapted to their work; belting was repaired and put in first class condition, under the charge of one man. Machines were rebuilt or accelerated. Grindstones were taken out and replaced by modern abrasive wheel installations. Small tools were standardized, and made under best economical conditions in the tool room. Leaks in air and steam lines were stopped, etc. This preparatory period consumed nine months.

The next step was to evolve a method by which the actual cost of every operation could be determined. Costs consist of direct labor, of a machine rate and of indirect charges. Direct labor and machine rates, in determining

costs, are figured by the hour, and the indirect expenses are provided for by carrying them as a percentage of the direct workers' wages. For instance if a certain job takes three hours; if the man's rate is \$0.30 an hour, the machine rate is \$0.50 an hour, and the surcharge for the department 80 per cent of the man's rate or \$0.24 an hour, then the cost of the operation is:

For direct labor.....	\$0.90
For machine charge.....	1.50
For surcharge.....	0.72
Total cost .....	\$3.12

If by a better worker, or with a better machine, the work is done in two hours, then the cost becomes:

For direct labor.....	\$0.60
For machine charge.....	1.00
For surcharge .....	0.48
Total cost .....	\$2.08

Not only is the cost of the operation reduced 33 per cent in this latter case, but the output of the shop is increased from 3.3 to 5 per day, a gain of 50 per cent. All machine and surcharge rates having been determined, the next step is to standardize the necessary time for doing any particular job. If to take the above example, two hours is a reasonable time, it would be made a standard. Many jobs are continuously repeated, and these were standardized first. As to every job standardized, we had thereafter the standard time it ought to take, and the time it actually did take. As already stated a bonus of 20 per cent was paid for reaching standard time, a larger bonus for beating standard time, a lessened bonus for less than standard time, there being no bonus for a time equal to standard time and a half. Decimal time was adopted, observations were made down to tenths of hours, and thus we never vary more than 3 minutes from accuracy. If many of a smaller article were made, they were grouped together, so much standard time for 10 or for 100. Some men would have but a few of their jobs standardized, working day work on other jobs. Others had a large part of their work standardized, but not all.

The objections to this system were that men hurried unduly on the bonus jobs, and rested up on day work jobs, so that the employer lost. Assume that under the old day work system, two jobs each took five hours, and cost in labor \$2.50 and that one of them was standardized to four hours. The expectation of the employer was that he was to pay 20 per cent bonus for the four hour job, or \$1.20, that the worker would still take five hours on the day work job, costing \$1.25, a total of \$2.45, and that as an equivalent for the 20 per cent bonus there would be an hour saved. If, how-

ever, the worker took three hours on the bonus job and was paid \$1.20, and was then so tired that he took seven hours on the day work job and was paid \$1.75, the total cost to the employer became \$2.95, and he not only did not save an hour, but the work actually cost him \$0.45 more, the total amount of the bonus. While such cases were rare they occasionally occurred.

We took nearly two years to standardize most of the operations, and then we were ready for the final step, which was to use a standard cost for every operation, most of them being time study standard cost, and the few exceptions being provisionally standardized by the machine shop foreman or some other authority. These standard costs, not the actual costs, are now used by the accounting department, and the advantages of this method, both from the accounting, operating and moral point of view, are very great.

The gain to the accounting department is that costs are standardized, known and ready to be entered before the job is begun. The gain to the operating department is that the efficiency of every worker on the job, and of every foreman, and of every department, becomes a matter of record, and weak and therefore costly spots, dead quite as often to the machine, material, and method conditions as to inferior men, can be bettered. The moral gain is the highest of them all. When an employer sees that a competent worker, by earning increased wages is steadily reducing standard costs, he ceases to be troubled about high wages, and becomes deeply interested in efficiency, especially as an effort to reduce the bonus would instantly decrease the efficiency and therefore increase the unit of cost.

Instead of disagreeing about wages, both employer and employe are in full agreement as to efficiency. It is not possible always to avoid re-adjustment of wages. When wages are going up, wages under Individual Effort are advanced to the prevailing scale. If wages go down they may also be reduced under Individual Effort. Any change of wages might be obviated, if standard wages were so low as to be below usual variations due to hard times, and if Individual Effort earnings were so high as to be above even the highest outside scale, but such a situation may not be desirable.

At the present time at Topeka men are paid the standard rates of pay. All their work is on Individual Effort, their efficiency is the relation for the whole month, between the standard times and actual times. Standard times are fairly and carefully deter-

mined and are made easier in boiler shop than in machine shop, easier in the blacksmith shop than in the boiler shop, where a worker willing to strike a hot forging hard and often on a warm summer's day deserves higher reward than one who can increase speed rapidly without special personal discomfort.

For 100 per cent efficiency a worker receives 20 per cent bonus on his pay, for 90 per cent efficiency about 10 per cent bonus, for 80 per cent efficiency about 4 per cent bonus, for 73 per cent efficiency about 1 per cent bonus.

In the other direction, for 110 per cent efficiency the worker receives 30 per cent bonus, for 120 per cent efficiency he receives 40 per cent.

The Individual Effort workers in the machine shop at Topeka for the month of March were classified as follows:

2	between	15 and	20	per cent.
1	"	...	"	28.5
4	"	30	"	40
13	"	40	"	50
17	"	50	"	60
23	"	70	"	80
27	"	80	"	90
49	"	50	"	100
24	"	100	"	110
29	"	110	"	120
13	"	120	"	130
9	"	130	"	140
6	"	140	"	150
5	"	150	"	160
2	"	160	"	170
3	"	170	"	180
1	"	...	"	210

The effort of the general foreman should be to bring all the men now on the wrong side of the average line over onto the right side, beginning, of course, with those who are lowest. Mr. Emerson recently read a paper before an audience of the University of Chicago, which I would like to read if time permitted, but as it is already in the hands of most of the members I confine myself to a few extracts. The paper brings out clearly Mr. Emerson's theories.

Firstly: That the employer and worker can make far more by eliminating existing losses than they can through antagonism to each other. Secondly: That the best and therefore highest paid workers are the cheapest and that the rate of wages is insignificant, compared to the efficiency. Thirdly: That an opportunity to determine his own rate of pay, coupled with a certainty of absolute fairness from the employer, and congenial surroundings, will attract and hold the highest class of workers, high in character, in reliability, in efficiency in output.

To emphasize the uselessness, not to say criminality of the antagonism between employer and employed, he uses the simile of two half starved hunters, joining in the pursuit of a buffalo. One is a skilled hunter, able to follow the quarry, the other has rifle and knife. The skilled one guides the armed one until the game is run down

and killed. A fire is built and the tongue cut out and then the two fall to quarrelling and both want it all, and while they disagree and fight, the whole carcass, big enough to feed 500 men, spoils, is devoured by wolves and the salable pelt is ruined.

The antagonistic combination of capital and labor is to-day so inefficient that neither claims half of what it might have, if useless wastes were eliminated and all effort positively directed. In periods of great activity both wages and profits rise, in periods of depression both wages and profits fall, but periods of activity can be indefinitely prolonged, periods of depression be much curtailed, by increasing efficiency and eliminating wastes. It is particularly the duty of the employer to point the way, to hold out the hand of peace and good will in joint effort, and when the hand is held out is not less the worker's opportunity and duty to show that he can also do his share.

Mr. Emerson makes the startling assertion that the average efficiency of all men of militia age, i. e., between 20 and 40, is not over 5 per cent and that under perfect conditions, either twenty times as much could on the average be accomplished or the 5 per cent of the present militia population could do it all. If this is even reasonably true, why is there any such question as woman and child labor? The startling assertion that the efficiency of the average total male population is not more than 5 per cent and the average worker only 50 per cent of what it normally should be, the enormous difference between 5 per cent efficiency and 80 per cent, what it should be certainly makes our ears tingle, when this statement shows a chance to increase reward of labor 100 per cent and at the same time cut prices 20 per cent and double the returns to capital, solely by eliminating inefficient methods, inefficient machines, inefficient men and wasted materials.

To increase wages and at the same time the returns to organizers, thereby bringing about a genuine reconciliation of and between those who work and those who direct, is the mission of the Individual Effort System. To determine the present unit cost of production down to the most minute operation, lower the unit cost by increasing the efficiency of the organization, methods, machines, materials, the individual workers. Cost to the public reduced, benefiting indirectly all, including those who want the much discussed 2-cent fare. All this may seem strange, and like the chasing of a phantom, the consideration of platitudes, but to one who has watched the result of the application of these methods, the actual,

enormous increase of output, the cheerful handing over of from \$40 to \$50 per month to workers in addition to their regular wage, it does not seem so strange.

To hear the grumblings cease, to hear that such and such men left the service because they were not given an opportunity to work on the Individual Effort plan; good workers, for the time being on some work where schedules were not established, leaving because they were not transferred to work where schedules were in force. Time and place will not permit of going into minute details of figures, or of cards, work slips, checks, diagrams; nor a description of the dispatcher-like board used by the general machine foreman who with the assistance of a couple of clerks, a messenger boy, some convenient telephones, can keep the whole shop lined up, and at the end of the day or week know to a certainty how long it took to do each job, what machines it was done on, how much it cost, how many hours any machine was idle, what machines and who were most efficient among the workers. This dispatcher-like board has been photographed and described at length in some of the technical journals recently, as well as the various methods employed in working out the Individual Effort System and the further development of the efficiency plan; and how it has built up and refreshed the interests until instead of mere routine, uninteresting work-a-day, oftentimes luke warm efforts, there is keen business enterprise, so injected into the day's business, that all take an active part and a proprietary interest. I have heard more kicking because men whose business it is to get material to and from machines and men who were supplying material did not get it around in time, so that workers who were about done with one job could look over the next job and make proper preparation to attack the next job, than I can give account of here.

To those interested I would also say, come to Topeka, or visit other points on the Santa Fe System, and see for yourself and judge the results. If any of you have any misgivings about material being spoiled and lying about in a mangled state, as some of us were led to believe would be the result when we started in on this system, look over a car load ready for shipment, take gauges, templets, drawings, rule and calipers, and see for yourselves.

(Continued on page 311.)

The deepest wounds are made with the tongue. Bullets may be removed, but no probe can reach far enough to locate a bitter word.

# General Correspondence

## Old-Time Engine.

Editor:

There are few earlier subscribers than I for your excellent paper, and your uniform fairness to employer and employe is admirable. Your historical articles on the evolution of the locomotive are interesting to a "past master" throttle puller like myself, though I did not stop there in railroad service.

In illustrations of old and curious locomotives, I do not remember to have seen one like the blue print I am mailing with this, but I can give you nothing of their history further than as I saw them as a young boy on the Old Colony and Newport R. R., now N. Y., N. H. & H. R. R. At that time they pulled suburban trains between Boston and stations south of there. This was in the early sixties, at the time of the Civil War, and to see one of these little engines and a big freight engine—a 16 x 24-in. cylinder engine was a big one then—double heading with a trainload of soldiers going to the war was a sight, to my youthful eyes. As is characteristic of railroad men, they were nicknamed "pups," and I then resolved that when "I was a man" I would run a "pup," or maybe a big "Blood" engine. I later realized my ambition to run an engine, but never ran a "pup" or a "Blood." By whom or where these engines were built I do not know. The print shows the end of machine shop and wall of roundhouse of the N. Y., N. H. & H. R. R. in South Boston. You can see that they were no mean engine when you read the name of the first governor of Plymouth colony, "Governor Bradford," on the side of the cab. You may be able to get the history of these little engines by writing to some old employe of the "Old Colony Railroad." We may say they (the "pups") were very small, but they no doubt filled their purpose in their day as we do ourselves. I am glad of your success and enjoyment of a long, useful life.

GEO. H. BROWN.

Dubuque, Iowa.

## Perfume Too Expensive.

Editor:

I received in due course your letter asking for photographs and blue prints of an alleged perfume-distributing car which, according to a report published in the *New York Times*, is used in the Paris subways for perfuming the tunnels and roadway. I sent at once for the *Times* correspondent who had sent the

story, who confessed that he had taken the yarn from a paragraph in the *Figaro*, but had not made any investigation to confirm it. This he promised to do, however, and send me the facts without delay. This he has not done, for the evident reason that no such perfumery car exists or has ever been used here.

What is true is this: During the past winter there was a serious epidemic of la grippe in Paris, with tendencies to pneumonia, and the doctors were accustomed to say that the subways of the Metropolitan railway system were infested with germs of such diseases, and advised their patients and friends to avoid the "Metro."

## Natural Desire to Advance.

Editor:

There is one thing in the railroad world that has puzzled me considerably, and I write you for some light on the subject. What is the reason that nearly if not all of our railway managers, such as train masters, assistant superintendents, superintendents, general managers, vice-presidents, presidents, etc., come from the ranks of the office men and train department? You very seldom hear of promotions from the ranks of enginemen.

Now, if there is any class of railroad men in the ranks that should know all the ins and outs of a railroad it certainly are the enginemen. Why is it they are



THE OLD ENGINE, "GOVERNOR BRADFORD," ON THE O. C. R. R.

Accordingly, the management of the subways tried to meet the crisis by sending round sprinklers, that is, plain, common trucks carrying a tank of water in which some germicide had been dissolved. This was carried down to a transverse perforated pipe which sprayed the tracks and roadway like an ordinary street sprinkler. There was nothing original, ingenious or interesting about these temporary sprinklers, nothing deserving a blue print or any notice whatever.

As to perfuming the subway, there has never, so far as I know or can ascertain, been any thought of such a thing. It was all in the aesthetically imaginative brain of the *Figaro* reporter. The Paris "Metro" is a very practical and business-like concern, which does not spend money for perfumery.

FRANK H. MASON.

Paris, France.

Consul-General.

so seldom picked for promotion? Is it because they are generally found with a dirty face and hands and greasy clothes? We are, as a rule, more interested in getting our train (what don't belong to the conductor) over the road, rather than our personal appearances. Probably that has some bearing on the proposition. You are well aware of the fact that we engineers are quite frequently compelled to obey the orders of officials that we know are really silly, absurd and unreasonable. I can call to mind one bulletin that was issued some time ago on one of our western roads: "Notice to Engineers—Rough track will not be taken as an excuse for delays to passenger trains in the future." Results, several serious derailments whereby the road was blocked for hours at a time. This order was not only absurd and unreasonable, but criminal.

Engineers on fast trains figure time by

the second, conductors by the minute, dispatchers by the quarter hour, train-masters by the half hour, superintendents by the one hour, general managers by the day, presidents by the month, board of directors by the year, stockholders by the time between dividends, as they are of such uncertain periods, but very desirable at any time.

set about making a hammer in which the work of the valve should be done by the piston itself and at the same time put on the market what he considered to be a more satisfactory hammer.

The large chipping and riveting hammer No. 1 has been put to every test a hammer is likely to be put to and in

An examination of the piston and the interior of the cylinder after the hammer had been used for some time disclosed no signs of wear and this shows that piston must be perfectly balanced.

By further reference to the cut it will be noticed that the bushing at end of cylinder may be forced back into the cylinder, thus shortening the stroke and giving a much lighter blow.

As there are in this tool no parts subject to any very great amount of wear or liability to breakage it would seem that this tool is likely to fill a long felt want, and especially is this true where hammers are used in places remote from repair shops.

Hoping you may be able to use this description and illustrations in your valuable magazine.

Stroudsburg, Pa. RAYMOND S. LEE.



LARGE AND SMALL AIR HAMMERS OF NEW DESIGN.

In writing you this article I only want to convey to you my feelings in this matter. I have been in the engine department for nearly 20 years, am now running an engine in freight service. It is my desire to advance to a higher position, but it looks as if I am done, as if there was nothing for me to strive for. I have a first class record as an engineer, take an active interest in my work, also in the work and welfare of the company and my co-employees. I am aware of the fact that I am in the wrong department for any higher promotion. What would you advise? I do not want to stop here. I want to go higher. I want at least a trial and an opportunity to develop, to become something more than just an engineer. You can use the enclosed article as you see fit. Use it as a basis for an editorial or publish it after your own style. I have tried to convey the idea.

FRED STIFFLER.

Leadville, Col.

**New Air Hammer.**

Editor:

Enclosed you will find photograph and description of an air hammer recently patented by one of our former employes at this point, which I thought might be of interest and use to you in RAILWAY AND LOCOMOTIVE ENGINEERING.

While Mr. J. Frederick, the patentee, was employed as tool room foreman at the New York, Susquehanna & Western shops at Stroudsburg, Pa., he had troubles of his own with the various air chipping and riveting hammers in use on account of the delicate and complex valve motions and the difficulty of making repairs to same and finding the chief source of trouble with the hammers to be in the valves, he

every case has proved to be a better controlled and heavier hitting hammer than any of the heavier and longer stroke hammers used in the test.

The smaller hammer at the right of the picture, No. 2, is designed for granite chipping, etc., and it also has proved very satisfactory.

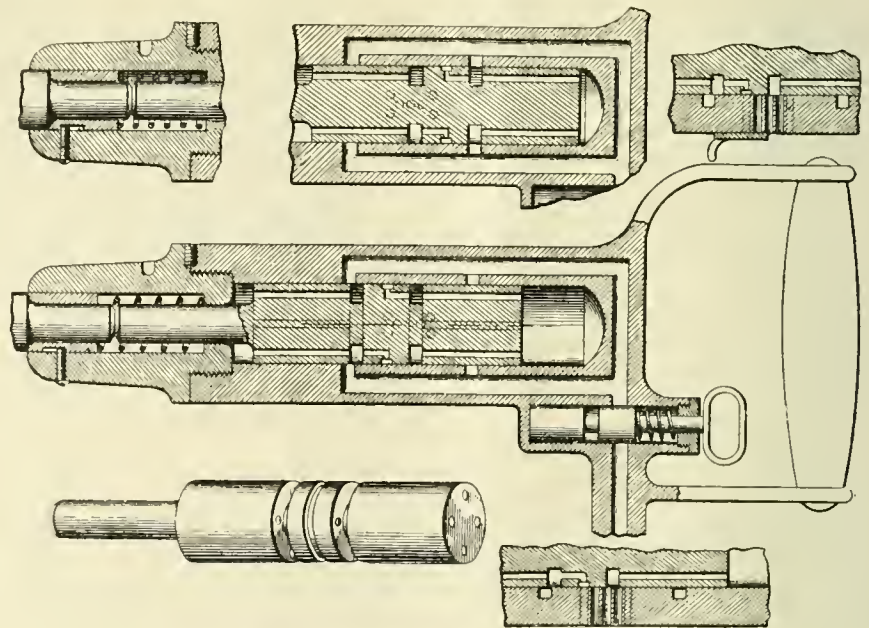

AIR HAMMER USED IN THE N. Y. S. & W. SHOPS.

A glance at the line cut will show the internal parts of the tool. These consist only of a cylinder having ports in proper places and a solid piston with ports and annular grooves. This piston controls the admission and exhaust of air to and from the cylinder and the speed of the tool may also be governed by closing the exhaust ports with the hand.

**Westinghouse E T Brake.**

Editor:

There is a certain class of railway employees, both in road and shop service, who vigorously oppose all new devices in railway equipment; some oppose everything on general principles, some because they do not understand the operation of new appliances, others because they do not un-

derstand and are unwilling to put forth any effort to become familiar with improved inventions. Were this element in the majority a deplorable condition would exist on American railroads today for no doubt the locomotive boiler would still be fed with a pump and the standard brake would be a three-way-cock and the reverse bar.

The new Westinghouse engine and



tender brake is one of the latest with which fault is being found; as could be expected, its strongest points are the ones to be attacked. While complaints against this brake are being made on account of brake sticking, a description of its construction will show that while the brake valve handles are in their running positions the application chamber of the distributing valve is always open to the atmosphere and there can be no creeping on or sticking of this brake due to leaky or overcharged brake pipes.

The release of this brake does not require a high main reservoir pressure, there is no frictional resistance of the triple piston and slide valve to overcome and no variation of brake pipe and auxiliary reservoir pressure to contend with, the release, under ordinary conditions, is as positive as screwing the oil plug out of the brake cylinder.

This positive release feature alone will justify its adoption in all classes of service regardless of the efficiency of the brake previously used. There is, however, a possibility of this brake sticking should the main piston of the distributing valve break or stick or its expander ring work out of place and lodge between the piston and cylinder cover, the equalizing piston and slide valve may not be moved to release position due to friction or packing ring leakage and prevent the recharge and following automatic application but it cannot affect the release of the brake. In double heading should the leading engineer fail to move the equalizing valves of the distributing of the second engine to release position the second engineer can always release his brake with the independent brake valve.

The undesired emergency so often encountered in the operation of the highspeed brake with the G6 brake valve and the quick action triple valve on the tender, has been the cause of lengthy discussions, frequent complaints and numerous delays; no doubt a great deal of this was due to the condition of the tender triple valve, especially where the 8 in. brake cylinder and F36 triple valve were used as the high auxiliary reservoir pressure has a tendency to squeeze the lubrication from the triple slide valve and cause the piston to move more rapidly in applications, the graduating spring of the F36 triple valve is less able to withstand the shock of stopping the triple piston and slide valve in service position than is the heavier spring in the F27 triple valve.

Although the service ports in the two triple valves are of the same size and the capacity of the 10x24 reservoir is but one-half that of the 12x33 the amount of compressed air to be ex-

panded does not affect to any appreciable extent the movement of a slightly sticky triple piston against the graduating stem. Complaints of this undesired quick action were not of such frequent occurrence where the 10 and 12 inch equipment was used under the tender and with the ET. brake equipment this trouble cannot occur and owing to the length of brake pipe between the H5 brake valve and the first triple valve in the train the quick action is not so apt to occur from slight disorders of the brake valve.

On a locomotive where the driver and truck brake is operated by a triple valve there is a limited supply of compressed air stored in the auxiliary reservoir and on the initial reduction from the brake pipe there are three brake pistons to be moved and the space in the cylinders to be filled before sufficient pressure can be accumulated to register on an air gauge, the consequent loss of braking power varies with the condition of the packing



MODERN 2-8-0 ON THE BIG FOUR.

leathers and the equalizing piston in the brake valve.

There are some engines in all round houses whose brake cannot be applied with less than a six or seven pound reduction in brake pipe pressure due to worn packing leathers, and expanded rings which do not hold the leathers firmly against the walls of the brake cylinders.

With the new air brake equipment the brake cylinder pressure is determined by the pressure in the application chamber of the distributing valve and the supply is only limited by the capacity of the air pump.

This brake possesses many advantages in operation, construction and economy which have been cited in these columns and others will be in the future as they are discovered.

G. W. KIEHM.

Washington, D. C.

Don't expect large things from a little minded man. Some folks are built on the penny scale and weigh that much only.—C. H. Yatman.

### Heavy 2-8-0 Engine.

Editor:

The large consolidation locomotive shown in the photograph which I am sending you belongs to the Big Four, or C., C., C. & St. L. Railway, which is now a part of the New York Central system. About one hundred similar engines have been received by the Big Four from the American Locomotive Co. within the last two years, 30 of them having the Walschaerts valve gear. The locomotives are of the New York Central standard type, and are the heaviest ever used on the road. The photograph might prove interesting to readers of RAILWAY AND LOCOMOTIVE ENGINEERING should you see fit to give it publication.

R. C. SCHMID.

Lafayette, Ind.

### Theory vs. Practice.

Editor:

There was a time when some of the able men at that period connected with locomotive design thought that the closer to the cylinders the throttle valve was located the better results would be had. Some throttles were placed in the bottom of the smoke arch, and many were at the top of it, and when Wm. Mason & Co. built the Fairlie engine and brought the steam from the dome through the smoke arch back to the centre bearing of the engine and then forward to the cylinders, it was considered bad practice. Mr. Eddy, of Boston & Albany fame, considered much of his success was due to having the throttle in the smoke arch, and during the seventies the C., R. I. & P. took the balanced valve from the dome and located it in the smoke box, claiming a benefit from so doing. But time changes many things. With engines using the Cole superheater, the throttle is in the dome and the steam passes along the length of dry pipe into the heater manifold, then back near to the fire box and is returned to the smoke box, and then to the cylinders, showing a gain of much value; in fact, so much that an engine by this arrangement will do fully as much work with 175 lbs. of steam as an engine with the steam pipes direct from dry pipe to cylinders can do with 190 lbs. of steam, a gain of 15 lbs. On the Canadian Pacific their superheater accomplishes much more. They make the steam travel to near the fire box and return twice before starting for the cylinder, and by so doing their engines do the same work with 170 lbs. of steam as an engine with steam pipes direct will do with 210 lbs., a gain of 40 lbs. This should satisfy the most skeptical that the farther the steam goes after leaving the water in the boiler before reaching the cylinders the more power it has, and to go on with this line of reasoning, how much would the gain be

if it was arranged to pass the steam through these pipes eight times in place of four? Would not the same proportion of gain be shown? That would let us have a pressure that would reduce the cost of boiler repairs most wonderfully, and if it would not do so, please tell us why.

A. SHEUMACHER.

Philadelphia, Pa.

**Engine vs. Push Car.**

Editor:

The enclosed photograph is of a pilot beam which was removed from one of the engines running on this division of the Southern Pacific. The engine ran into a push car loaded with rails. The photograph shows the 80-lb. rail which penetrated the 12 x 12-in. oak beam, striking

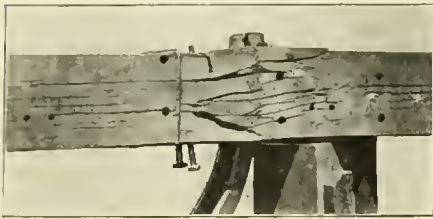

RAIL DRIVEN THROUGH PILOT BEAM.

the back plate, which is 1 x 12 ins., and bending it back 4 1/2 ins. from its face. This plate prevented it from entering the cylinder casting at the saddle. The rail had to be cut off in order to let the engine proceed, it being almost impossible to extricate it from the beam out on the road.

Fruitvale, Cal. W. W. UPDEGRAFF.

**Bracing of Flue Sheet.**

Editor:

Thinking it would interest some of you readers I am sending you a blue print of flue sheet braced as directed by our master mechanic Mr. J. A. Gib-

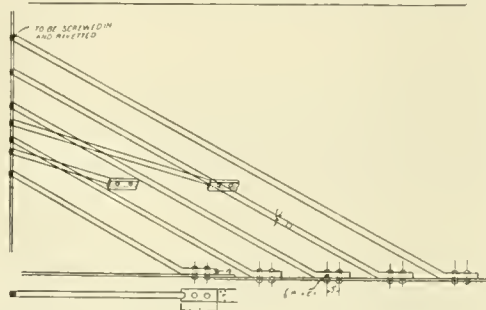
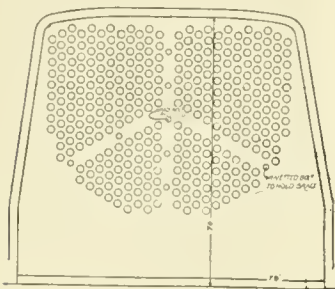

METHOD OF BRACING FLUE SHEET. BIG FOUR.

son. These flue sheets are 78 ins. wide with 370 flues. Mr. Plowman, our boss boilermaker here on the Big Four, braced one of these sheets on April 18, 1905, and one December 23, 1906. These engines have been in constant service since these dates and flue sheets are comparatively straight at this date.

Hoping you will find space for this in your valuable paper.

Urbana, Ill. W. S. BUCHANAN.

**New Coal Gates.**

Editor:

The need for something better in coal boards has long been recognized, and many devices have been patented, but did not prove desirable. The Briggs coal gates patented by Frederick E. Briggs, of Carbondale, Pa., November 13, 1906, seem to meet the want and are the best yet invented. A trial of them will prove all that is claimed for them—safety, durability, convenience, money savers; when properly applied. By mistake in blue print some new engines built for D. & H. have gates wrongly applied, making them practically useless. The place to see them in perfection is at Carbondale, Pa., where a set has been in use over a year and are all right yet, end on collisions not moving them.

Stevensville, Pa. M. K. JONES.

**Boring Device.**

Editor:

Being a reader of RAILWAY AND LOCOMOTIVE ENGINEERING for a number of years and feeling interested in it, I am enclosing photograph of a little device designed and made at the Queen & Crescent shops at Ludlow, Ky. You will notice this is a small boring bar made suitable for boring out main valve bushings in the 9 1/2-in. air pumps. This little device is quickly attached and main valve bushing bored out in less than 5 minutes. It can be easily attached to pumps in position for making roundhouse repairs.

I not only find this a neat little saving in labor, but also in expense in making repairs. The handle to the left is the feed handle, and one to the right is the power handle, and it is very

**Ulster & Delaware Ten-Wheeler.**

Our illustration shows an ordinary ten-wheel engine (4-6-0) for the Ulster & Delaware Railroad, built at the Schenectady shops of the American Locomotive Company. This engine is simple, with 20 x 26 ins. cylinders, and balanced slide valves, actuated by shifting link motion. The tractive effort of this engine is 28,100 lbs., and the factor of adhesion is 4.4. The driving wheels are 63 ins. in diameter, and all are flanged. The guides are arranged for an alligator cross-head, and



DEVICE FOR BORING VALVE BUSHINGS.

the top guide bar is recessed on the edges so that the side of cross-head and bar are flush. The butt end of the main rod is forked, and all the rods are of I-section.

The weight of the engine itself is 164,000 lbs., and the adhesive weight amounts to 125,000 lbs. With the tender the weight of the whole machine is 271,600 lbs. The wheel base of engine and tender together is 52 ft. 1/2 in. The engine wheel base is 24 ft. 9 ins., with a driving wheel base of 14 ft.

The extension wagon-top boiler of this engine measures 62 1/4 ins. outside diameter at the smoke box end, and the fire box is of the wide type, inasmuch as it extends out over the frames. The fire box side sheets are straight and the crown and side sheets are made of one plate, and the roof sheet and the side casing sheets are one. It is 96 3/8 ins. long by 65 1/4 ins. wide, and has a grate area of 43.5 sq. ft. The taper sheet is the second course and slopes up about 8 ins. The heating surface is in all 2,412 sq. ft., being made up of 143.9 in the fire box and 2,268.1 in the tubes, which latter are 304 in number and 14 ft. 4 ins. long. The ratio of grate area to heating surface is as 1 to 55.4. There is a slight slope toward the rear end of both crown and roof sheets,

easily operated. We have many other small tools which we find very saving in making quick repairs to air pumps.

J. B. CHILDS,

General Foreman Queen & Crescent Shops.

Ludlow, Ky.

with a 22¾ ins. steam and water space between them. The back head slopes forward about 12 ins. There are six washout plugs along the level of the crown sheet, placed in the fire box casing sheets, and three in the back head.

The tender frame is made of 10-in. channels and plates, and the trucks are of the arch-bar type, with 33-in. Boisse wheels. The tank has a water bottom and holds 5,000 U. S. gallons of water and 9 tons of coal. The cab is roomy and made with three windows on a side, and altogether the engine is a neat and serviceable looking machine. Some of the principal dimensions are as follows:

Driving Journals—All 9 ins. x 11 ins.

Engine Truck Journals—Diameter, 6 ins.; length, 10 ins.

Tender Truck Journals—Diameter, 5 ins.; length, 9 ins.

Boiler—Type, extension wagon-top; working pressure, 200 lbs.; fuel, bituminous coal.

Fire Box—Thickness of crown, ¾ ins.; tube, ½ ins.; sides, ¾ ins.; back, ⅝ ins.

### General Foremen's Association.

(Continued from page 306.)

#### STORES DEPARTMENT AND SHOPS.

The report on the "Relation of the Store Department to the Shops" was Topic No. 4 at the recent meeting of the General Foremen's Association. The committee making the report was composed of five members. Mr. G. W. Keller, of the N. & W., was chairman, and Messrs. Thos. L. Drew, of the B. & O., and J. R. Crowley, of the Central of Georgia; W. Pholman, of the N. Y., O. & W.; J. C. Wilkinson, of the Rock Island, formed the committee. The report, as follows, is slightly abridged:

The relation of the store department to the shops should be very close, and the best of feeling should exist between the store department people and the foremen in the shops. It must be remembered that the store department at all large shops

#### ANTICIPATION OF WANTS AND PREPAREDNESS

To be prepared to meet emergencies covering every day "running repairs" and accidental breakdowns there should be a fair supply of all kinds of material, covering the different classes of engines, kept in stock and properly maintained in store house and stock room. In stock room there should be on hand and maintained a limited stock of duplicate standard parts machined and finished as far as practicable, ready to meet an emergency break-down. Being so prepared, there is little delay experienced in getting an engine serviceable for the road.

Anticipating engines to be drawn from service and shopped for general overhauling. A careful inspection should be made by each foreman of the different shops at least thirty (30) days prior to the date intended to shop engine; a memo made by each of the repairs and renewals required as far as possible.

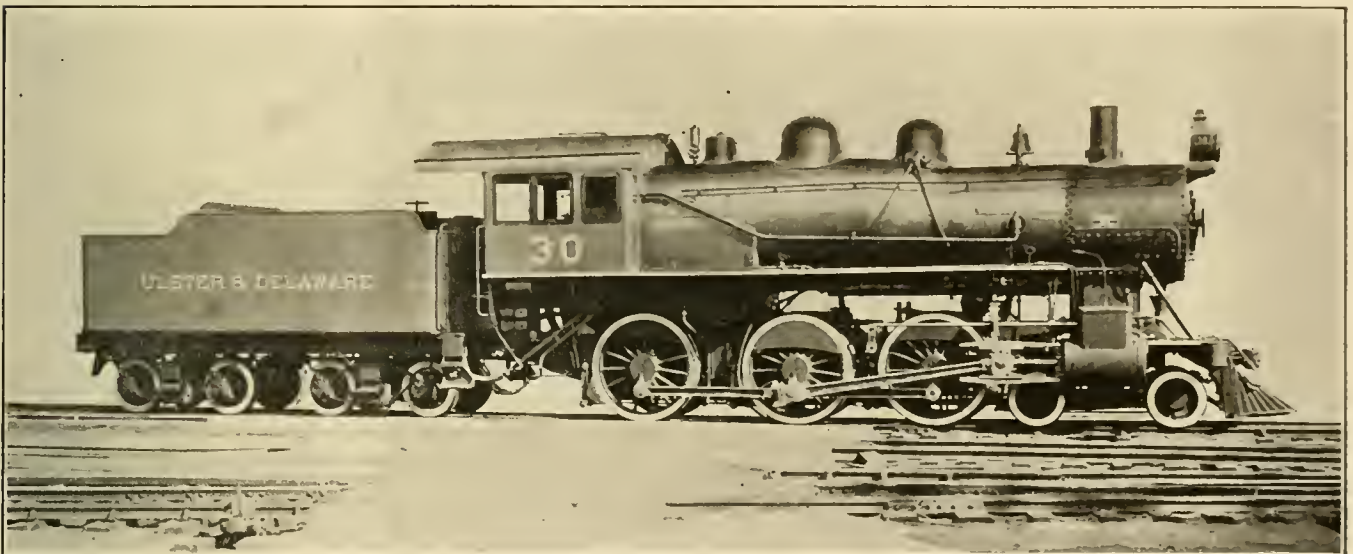

TEN-WHEEL SIMPLE ENGINE FOR THE ULSTER & DELAWARE.

M. R. Coutant, Master Mechanic.

American Locomotive Co., Builders.

Fire Box Water Space—Front, 5 ins.; sides, 3½ ins.; back, 3½ ins.

Air Pump—9½ ins. L. H.; one reservoir, 24½ ins. x 136 ins.

Engine Truck—Four-wheel, with cast steel swing frame and swing center bearing.

Piston Rod—Diameter, 3½ ins.

Smokestack—Diameter, 16 ins.

Valves—Type American balanced; travel, 5½ ins.; steam lap, ⅞ ins.; ex. lap, line and line inside.

Setting—Line and line full gear ¼ ins. lead at ¼ stroke cut-off.

Wheels—Engine truck, diameter, 30 ins.; kind, Boies.

Driving Boxes—Gun iron.

The story is told that a workman in the Rogers Locomotive Works having suggested some small improvement to Thomas Rogers the latter took a ten-dollar bill and gave it to the man on the spot. Rogers' workmen were always suggesting improvements and they were generally rewarded on a small scale by the founder of the works.

has a great deal of work to do and has to carry a very large stock on hand on account of so many different classes of locomotives. And if the store department and the shops are working together, hand in hand, they can be a great help to each other. The store department can have a stock clerk, and he doing the very best he possibly can do to keep the stock up; but there is a lot of material overlooked by him that the foreman can advise him of if their relations are in harmony with each other.

We think it a good idea for the store department officer to converse with the shop foremen when the time comes to place the regular monthly requisitions and see if they have anything to be ordered that probably they have overlooked. As soon as the foremen find out that the department is out of any needed material they should advise him at once, so that he can have it hurried.

Then each foreman should go over stock of material and duplicate parts peculiar to his department. If any necessary material or duplicate parts are not in stock, or due on requisitions, a special requisition should be placed covering necessary requirements in order that ample time may be given the purchasing department to secure and have the material on the ground when engine is shopped.

#### A STOCKROOM AND THE DISTRIBUTION OF MATERIAL.

There should be a room conveniently located in the shops for use as a stockroom for all finished material, and there should be kept finished and ready for immediate use all parts of the different classes of locomotives and especially the parts most often used.

There should be a capable man in charge of this room; one who is familiar with all the different parts of the dif-

ferent classes of locomotives, and he should run this on the maximum and minimum scale. When material gets down to the minimum he should at once place an order on the machine shop foreman for the material wanted, and this should be gotten out without delay.

Each gang foreman has certain low rate men who do all the trucking in and out of all material, and these are the men he could give orders to to go to stockroom for any piece of material he may want, thus saving the high price labor looking up this material.

Stockroom should contain finished standard pieces, and parts where it is not practical to finish, to complete as near as practical. For locomotive repairs such parts as eccentrics, eccentric straps, finished shoes and wedges (finished except on faces), driving boxes, except boring and hub facing; slide valves completed, links completed, pistons and crossheads, as near as practical; cylinder bushings bored and turned (as cylinders can be bored to suit bushing); cylinder packing for all cylinder diameters varying in sizes by one-eighth piston rod and valve stem packing completed, eccentric rod jaws finished ready for welding on, main and side rod ends finished and ready for welding on, crank pins finished, except fit; driving axles, except wheel fits; steam chests and covers completed, all classes of boiler checks and steam cocks, studs and bolts of various lengths and diameter. Stock for various classes of engines should be arranged separately and placed in stock room, where it could readily be observed, and replenished before it is all used, as delays are likely to occur waiting on castings or forgings.

Stock should be placed, and class mark or size, in a position where it is frequently passed by master mechanic and foreman. For instance, we have tried several methods of storing cylinder packing, and would find it invariably mixed by parties using it. We then had upright bins, each bin for its respective size, marked above it, and can observe when any one size needs replenishing, and so on with other material. Small brass fittings of standards are best handled by finishing and delivery to store room, to be issued on requisition when needed. Invariably where a new class of engines is secured by a railway company they will develop a weak part, and if this should be a part such as eccentric or strap, or steam chest, requires a stock of them on hand. It is well to first observe the cause of breakage either from imperfect material or faulty design; if the latter, the design should be changed before a stock of such parts is made, as this will avoid scrapping new and unused material.

Beginning with the seventh month of the fiscal year, measures should be taken

to gradually decrease in ordering, so that the year end will find only the actual wants of material on hand, and not tons of some certain parts and none of another.

The casting yard is a very important adjunct to a machine shop, and should be under the supervision of only one official, and he, in turn, have one certain man to keep it properly arranged, look after getting all orders and patterns for castings, see that castings are placed in proper places, and so arranged that they may be readily observed for the two-fold purpose of securing when wanted, and ascertaining the amount on hand when inspecting the stock.

Another class of stock that requires better attention than it generally gets, is second-hand car and engine truck wheels. The plan of handling this would suggest that as soon as a second-hand wheel is removed from the axle that it be measured and its circumference or diameter and bore of wheel fit be placed on tread with paint or white lead and wheel stored in a conspicuous and convenient place until a mate for it comes in, and then be mounted on axle. By



ROCK TRAIN, COLUMBIA RIVER JETTY.

this practice the company will get the full wear of wheels as soon as practical to get, and will avoid good wheels being found in the scrap pile.

#### MANUFACTURE OF FINISHED PARTS AND THEIR DISTRIBUTION.

All parts of locomotives on the system should be made interchangeable as far as possible when undergoing repairs, regardless of class. For illustration, we will take a Type B passenger locomotive with four drivers and four truck wheels, with 80,000 lbs. on the drivers, cylinders 18 x 24 ins., 170 lbs. steam pressure, equipped with No. 8 injector. As a comparison, we will take Type D freight locomotive with eight drivers and two truck wheels, with 116,000 lbs. on drivers, cylinders 20 x 24 ins., 160 lbs. steam pressure, equipped with No. 9 injector. This is about the way we find the majority of locomotives equipped on our railways of to-day, which are burdened with every build of locomotive known to man and fitted up with so many different attachments, which, if maintained in their original design, will require the making of hundreds of patterns.

In Types B and D, the No. 8 injector

should be replaced with a No. 9 injector, the same as on the freight locomotive, class D, and all boiler checks, feed pipe connections, tank hose, sleeves and couplings should be changed to suit, making them all one standard. This may seem, at first, extravagant, but it will work to economy very quickly, as I know of a railroad that has over a hundred locomotives of twelve different types ranging with steam pressure from 140 to 180 lbs., cylinders varying from 17 to 20 ins., diameter 24 to 26 in. stroke, using No. 9 injector for the past five years with the best results. In fact, the only complete injectors carried in stock are those at outlying points on branches, as at shop terminals they only carry repair parts. There are always injectors repaired for engines in shops that can be exchanged for roundhouse work, thus reducing the cost of carrying stock to a maximum, and this can be practiced in the case of blower valves, air pump valves, lubricators, water gauge and glass cocks, also cylinder drip cocks, and, in fact, all trimmings should be interchangeable on as many types of engines as possible.

The finishing of standard parts for the repairs of locomotives should be made on shop orders, and as many pieces finished on one order as in the judgment of the management will be most economical for the service. Thus all pistons, rods, carriers, packings, driving boxes, valves, pedestal shoes, wedges, except thickness, cylinder heads, steam chests, cylinder bushings, except 1-16 in. on outside left to make fit. In fact, you can have every new piece needed to repair the locomotive ready to apply as soon as it comes into the shop for repairs, and there is no waiting or delay for machine work.

Distribution of finished material to outlying points should be made through the supply department, and handled as far as possible by one man, who will become accustomed to the work and will be able to pick out and ship the material wanted from the description furnished by the party asking for it, instead of chasing the general foreman for the necessary information. The amount of stock to be carried at each point should be designated by the master mechanic, general foreman or some one competent to know what is needed.

#### NECESSITY OF HARMONY.

This is a very important subject, and one that comes close to all connected with above departments; in fact, we do not know anything along this line of more importance, not only to both departments, but also to the financial end of the railroad business.

We know of a case where about four thousand dollars worth of a certain kind of stock was carried for three years, and

not one piece of the material used. This was finally sold and the money put into smaller and more serviceable material, to the mutual advantage of shops and storehouses and to the financial benefit of the company. This is one of many similar cases that could be cited, but the above is enough to show the advantages derived from a hearty co-operation between the store and mechanical departments.

#### Roundhouse Ventilation.

The paper on "Roundhouse Ventilation" recently read at the convention of the International Railway General Foremen's Association by Mr. J. W. Cryslar, foreman on the Chicago & North-Western Railway, is as follows: "Topic No. 6, "Roundhouse Ventilation," has been divided under several heads; the principal one would seem to be the ventilation of roundhouses, and, in the first place, we are all ready to admit that a free ventilation is a necessity, as we are often annoyed and suffer from smoke and gases that escape from the locomotive stack that fail to escape from the roundhouse.

Those who are familiar with roundhouse work and practice understand the discomfort that is experienced by the workmen when two or three engines with fresh fires in them have been backed from under the smoke jacks to give the machinists a chance to examine the cylinder packings, or file a main rod brass, or make other adjustments that require a quarter or half turn of the drivers to get the defective parts come-at-able. Perhaps the engine has been left standing back from under the jack to allow the boiler-washers to remove the washout plugs, and as soon as the engine is again ready for a fire it is fired up, and the dense volume of smoke is suffocating, unless the roundhouse has been well ventilated. Just here I would like to remark that when the "Vitribestos Smoke Jacks" with oblong openings were first introduced we were favorably impressed with them, as we saw there was no necessity of spotting an engine closely, that it could stand within a range for four or five feet and still be under the jack. But they did not stand the weather and the blowers, but I understand an improvement has been made in the quality of the material, and we have some from the same company of a smaller pattern that are wearing well.

Many devices for ventilation have been tried, and when we get one that will give the workmen relief or comfort on a warm summer day when the doors and windows are all open, we find that it does not work so well in mid-winter; there is then a down draught of cold air through the same ventilator that was so serviceable in the summer.

The best I have seen are the wooden

ones built up about five feet high and are about five feet square, with ordinary lattice sides and placed one between each smoke jack, and a smaller one about two feet square of same pattern over each cab, on ridge of roof. These carry off practically all of the smoke and gases, and I believe would give great satisfaction if the side openings in the large ones were made adjustable or could be closed like any ordinary window shutter, so that we would not have too much down draught of cold air in cold and windy weather.

I presume that all or most of you know what the conditions are in a large roundhouse in cold weather, where engines are coming in and going out continually. The steam and hot water let out from boilers needing washout is usually wasted, let through pipes from each pit into sewer, but as it is impossible to carry off all this steam and hot water, a great deal of it arises from the pits, and with the escaping steam from the cylinder cocks and injector pipes, etc., fills the house with a fog so dense that it is almost impossible to find one's way through it, and it does not seem possible for any device in such weather to free the house of steam or fog. This is one of the worst things we have to contend with in mid-winter, and, of course, the warmer you can keep the house the less fog you will have to contend with, and this brings us to the question of heating, and this seems narrowed down to a choice between the two prevailing systems—steam or hot air.

There is so much difference in amount of steam or hot air required to heat different roundhouses, even of the same size, that it is difficult to make a fair comparison. The amount of fuel required depending so much on the location, as well as the amount of business done through its doors.

The most comfortable winter I ever spent in a roundhouse was hundreds of miles north of Chicago in a terribly cold climate, but the house was always warm. Why? Because the doors were only opened in the morning to let out a switch engine and one road engine for an accommodation train, and not opened again until about 7:00 P. M., when they returned from their day's work, so it was comfortable all day. We used to have plants in flower pots blooming in the roundhouse all winter. But where I now am we pass 175 or more engines in and out every day over our turn-table, and during the busiest seasons of the year many more, and during the busiest hours of the day some of these big doors are open all the time, and it takes a large amount of fuel to keep such a house warm and free from fog, whether it be steam or hot air. Taking these conditions into consideration, I must say that I have not had experience enough with

each system to enable me to decide which I would prefer.

Of the types of buildings, I have seen some different plans of engine houses that could not be called roundhouses. Two or more long buildings with a transfer table running between them, from which engines could be run in or out and head over curve in either direction.

These plans seemed to be gotten up for the purpose of doing away with the turn-table, which lately seems to be regarded with some disfavor, on account of its liability to break down, or by some locomotive engine getting into its pit and tying up a house full of engines. But it seems to me that our ordinary roundhouses, with turn-table in center, is the best, and most compact style that could be gotten up. I believe every roundhouse should have two or more outlets and facilities on both incoming and outgoing tracks for taking supplies of coal, water, sand and wood, and pits for cleaning fires and ash pans, and also pits or tanks, for blowing off the sediment from boilers as the engines come in and go out.

The turn-table should be handled by power motor, either electricity, compressed air or gasoline motor. I am personally in favor of a gasoline motor, as it is quicker than air and less liable to get out of order than the electric motor. Every roundhouse should be provided with drop pits and air jacks for removing and replacing drivers, engine trucks and trailer wheels.

The location of the roundhouse should be convenient to passenger depot, not over one mile distant, and should be fully as convenient to freight yards or yard master's office. The roundhouse foreman necessarily comes in contact with a great many division officials, from the superintendent down to the men under his jurisdiction in shops, but with none as frequently as with the yard masters, and with these he should keep in close touch. They should co-operate, work in harmony if they wish to succeed. In fact, harmony among the different departments of the division must prevail to get best results, and co-operation between the different divisions is just as essential to success. The welfare of the company depends largely upon the harmonious pulling together of all employes, and the valuable man is the one who is ready to utilize the services and ideas of other men.

The influence of the personality of the foreman is emphasized in the character of the employes. He should be of a cheerful disposition. His life a clean example. He should strengthen every man by standing with him as a man. Treat your men fairly and justly and you will, in nineteen times out of twenty, get good returns. Keep your men in a good humor. The cheerful labor is the best.

# Railway and Engineering

A Practical Journal of Railway Motive Power and Rolling Stock.

Published Monthly by

**ANGUS SINCLAIR CO.**

138 Liberty Street, New York.

Telephone, 984 Cortlandt.

Cable Address, "Loceng," N. Y.

Glesgow, "Locauto."

**Business Department:**

**ANGUS SINCLAIR, President**  
**JAMES KENNEDY, Vice-President.**  
**JAMES R. PATERSON, Sec'y and Treas.**

**Editorial Department:**

**ANGUS SINCLAIR, Editor.**  
**GEO. S. HODGINS,**  
**JAMES KENNEDY,**  
**J. P. KELLY,**  
**CLARENCE RENSHAW,** } Associate Editors.

**Advertising Department:**

**Eastern Representative, S. I. CARPENTER, 170**  
**Summer St., Boston, Mass.**

**British Representative:**

**THE LOCOMOTIVE PUBLISHING CO., Ltd.,**  
**Amen Corner, Paternoster Row, London, E. C.**

**Glasgow Representative:**

**A. F. SINCLAIR, 15 Manor Road, Bellabouston,**  
**Glasgow.**

**SUBSCRIPTION PRICE.**

\$2.00 per year, \$1.00 for six months, postage paid in the United States, Canada and Mexico. For other parts of the world, \$2.50, or ten shillings. Single copies, 20 cents. Remit by Express Money Order, Draft, Post Office Order or Registered Letter.

Mailing address can be changed as often as necessary—always give old and new address, and if you subscribe in a club, state who got it up. Please give prompt notice when your paper fails to reach you properly.

Entered at the Post Office, New York, as Second-class mail matter.

Copyright by Angus Sinclair Co., 1907.

For Sale by Newsdealers Everywhere.

## Thriving on Patents.

A great deal of praise has been bestowed upon the patent laws of the United States for their influence in securing justice to patentees; but the sunshine, even in this case, is not without its shadow. The lawmakers have been so anxious to enable real inventors to protect their rights, that they have provided means by which fraudulent claimants can collect royalties on inventions of no value and on inventions to which they have no just claim. Railroad companies were ruinously victimized by the patent claim sharks until they formed the Eastern and Western Associations, which examine patents and the claims of patentees. When a patentee makes a claim upon a railroad company for infringement of a patent, it is submitted to the Eastern or Western Association for examination. If the association agents report that the claim is unjust it is fought even to the Supreme Court of the United States if necessary. The expense of such a move is beyond the means of most people and it is a very common thing for users of mechanical devices that they patented themselves to pay royalties to associated thieves for permission to use their own inventions.

Profitable patent pretensions frequently inflicted upon the public have attracted people of high business standing to associate themselves with rogues who have organized into companies for preying upon the people. The plan usually adopted is to obtain control of some minor patented device intended for use on some popular form of mechanism. Makers of the machine never heard of the obscure patent and keep on turning out their machine or apparatus by their workmen. After a time the representatives of the obscure patent give notice that their patent is being infringed and demand damages. If the case should be taken into court the district and state courts nearly always decide in favor of the claimant, but should it go to the Supreme Court of the United States, trained experts investigate the claims and justice is generally done.

A railroad mechanic once turned farmer and in his new occupation devised certain improvements on implements and machinery. Among them he invented an improved clevis of a plow. Eight or ten years later, a patentee's agent called upon this mechanic-farmer and demanded royalty on the clevis, which had been patented four or five years before. On consulting a lawyer this man was advised to pay the royalty to avoid costly court proceedings and he actually paid royalty on his own invention till the patent expired. That is a representative case.

About 1833, Isaac Dripps, master mechanic of the Camden & Amboy Railroad, invented a spark arresting smoke-stack of the big balloon form, which became the prototype of that kind of stack and was used as the foundation for many patented stacks that earned lucrative royalties. Ten years after the Dripps stack was invented, the Camden & Amboy Railroad were sued for infringing on a patented stack of more modern design. The company beat the pirates, but it cost them a great deal of money and trouble.

In 1846 Willard J. Nicholls of Hartford, Conn., invented a foundation brake which he did not patent. The need for improved foundation brake mechanism was becoming urgent about that time and several inventors brought out appliances in that line which were patented. In 1851 Henry Tanner, a most enterprising pirate of other people's inventions, bought a controlling interest in a worthless patented brake, took in the Nicholls invention, and began selling patent rights to railroad companies. He did not confine himself to the device which he had bought or to the Nicholls brake, but sold promiscuously to railroad companies the right to use any kind of brake they preferred.

In 1853 Tanner began suing railroad companies for infringing his brake and juries invariably gave him judgment, so that he collected vast sums of money.

His claims at one time amounted to over \$90,000,000. A decree having been obtained against the Chicago and North-Western Railway, his representatives offered to settle for \$15,000,000 and passes.

About this time the Western Railroad Association got into working order and pushed the case to the Supreme Court of the United States, which decided against all the claims, and this line of fraud was exploded.

## Atlantic City Conventions.

The early summer has come to be looked upon as the time for the railroad men's conventions. A run to Atlantic City with its far-stretching boardwalk by the shining sea is a treat at any time. The great piers reaching their white arms into the blue waters attract thousands of visitors at all seasons. The railway conventions, as usual, seized upon the most advantageous position, the steel pier, and the supply men covered it with the latest mechanical devices used on railroads. The exhibits were highly interesting and formed at once an object lesson in the most advanced time and labor-saving devices and in the elegance and beauty of finished workmanship. A notable feature this year was the number and variety of machines in operation. The portability of electric drives has made this feature more ready of accomplishment and the railway men have cleverly taken advantage of this expeditious method.

As usual on such occasions, the social element manifested itself very pleasingly under happy conditions. The severe life of a railroad man does not in any way detract from his enjoyment of such brief hours of relaxation as come to him, and while the serious part of the meetings—the reports of the various committees, the presentation and discussion of original papers showing the results of valuable experimental work—received the closest attention, it was pleasing to observe that the meetings were not dragged out to unreasonable length, and that abundance of entertainment of a delightfully social kind was provided for the visitors.

The broadening influence of such meetings and exhibitions cannot be overestimated. Their growing popularity is an assurance of the continued interest which the future opens before them. The bringing together of the brightest minds in the railway world under the happiest conditions is one of the most gratifying results of the social conditions of our time, while the benefits to a large class of young men are appreciated by them, and are in striking contrast with the limited opportunities of past generations of mechanics to whom a mechanical exhibition like that at Atlantic City would have been the wonder of a lifetime.

### Workshop Words.

A very common expression used to designate a workman who has served his apprenticeship is to call him a "journeyman." The origin of this word is from the French *journée*, meaning daily, literally, one who works by the day, and the word *journal*, which we apply to the end of an axle, comes from the same root, and signifies that which turns or revolves as the earth does in order to make day and night. We also speak of the journeyman having learned his "trade." This word is from the Anglo-Saxon *trōd*, a footstep from which in time came the successive ideas of a path, passage, way, custom, calling, occupation or business.

Smith has its origin in the Anglo-Saxon word *smitan*, a stroke, and the smith was really in old times the man who in his work smote or struck the metal he worked. The goldsmith was the man who beat out and worked gold, and the word *smitten*, the past participle of *smite*, is easily connected with the Anglo-Saxon word. The blacksmith handled iron, and his blackened or sooty appearance when working at his coal fire is no doubt the origin of the first part of the designation applied to him. The word "smithereens" is derived from the broken up fragments due to repeated blows, so that to knock a thing to smithereens is practically to pound it to fragments.

Craft at one time meant skill, ability, art, and comes from the Anglo-Saxon *craef*, a word which had the meaning of skill. A craft, therefore, was a calling or occupation which required skill or dexterity on the part of the workman, and the handicrafts were such as called for manual skill. The meaning of craft, when applied to underhand behavior, is thought to come from the Welsh word *craft*, a hook or hold-fast, and in this sense it referred to seizing with the mind. The word *crafty* is therefore applied to one who exhibits a low or mean form of cunning.

There is a word we constantly use in connection with a locomotive, and that is the word *eccentric*. This is from the Latin *ex*, meaning out of, and *centrum*, the centre, and is that which is out of or away from the centre. The word *alligator*, as applied to an open-jawed toothed wrench, is called so on account of the resemblance to the mouth of that reptile. *Alligator* comes from the Spanish name, "*el lagarto*," the lizard. The word *locomotive* is compounded of two Latin words, "*locus*," a place, and "*motum*," to move, and engine is from the Latin *in*, meaning in, and *gigno*, to produce. The termination "*gin*" in the word *cotton-gin* is a contraction of the word engine. Spinning jenny is another expression in which the last word is a corruption of engine.

Our common word *wrench* has a cri-

ous derivation, and is closely allied with the word *wrong*. A *wrong* is something which is not right or straight; it is something which has been twisted or wrung. The Anglo-Saxon *wrang* is from *wringen*, twisted. If a Frenchman desires to imply that you are wrong, he says "*vous avez tort*," you have a twist, which is equivalent to our expression. *Wrench* is from the same root as *wrong*, and comes through the Anglo-Saxon form of the word *wreancan* to twist, and the word "*wrenc*" was used to signify an artifice, or as deceit. When you say you can give a man a "*wrinkle*," or a new way of doing a piece of work, you give him something which in its original sense meant an odd twist of the mind. Right is, in its primary meaning, straight, and wrong is that which is twisted or has been wrung out of the straight line or course.

### Promote Trainmen to Higher Positions.

Our correspondence department contains a letter under the caption "*Natural Desire to Advance*" which excites our sincere sympathy. It voices the complaint of the engineman who has performed his duties faithfully for years, proved himself a good reliable man, an example for others to follow; and yet this man's ability and training seldom exert influence to push him into the position of superintendent or trainmaster. The field of selection for railroad officials is not so large that a class possessed of the experience gained by enginemen should be fairly ignored, but that is really the state of the case in the existing methods of selecting officials.

The real obstacle to enginemen and other trainmen advancing in railroad service is the favoritism that helps office men who are all the time in evidence and are selected because better men have been overlooked. How often have divisions been demoralized by the selection of men for trainmasters or assistant superintendents who had no more training for practical outside work than an office boy.

There is such an ardent spirit of ambition among modern enginemen that their self-denying labors to improve their knowledge of the science of railroading ought to be better appreciated in the circles having power to order promotion based on merit. This is a sentiment that needs ventilating and we are persuaded that good would come of agitation in favor of promoting practical men from the ranks.

### Seth Wilmarth.

Seth Wilmarth, a picturesque figure as a locomotive builder, graduated from the old Hinkley shop, somewhere about 1848, and erected the Union Works on Foundry

street, South Boston. His first venture was for the then Boston & Worcester Railroad, for which he built three passenger engines, the *Falcon*, the *Fury* and *Bee*, and three freighters, the *Etna*, *Niagara* and *Bison*, all patterned after the Hinkley engine of those days, with extremely short boilers to accommodate the engines for the short turntable for which the directors of the road spoiled all their engines.

His next attempt was a couple of passenger engines for the same road, the *Hale* and *Henshaw*, which were large engines for those days, having cylinders 15x22, 66-in. drivers, and a 46-in. shell, with long tubes.

These engines proved quite successful, when running, as they passed a good deal of their early life in the repair shop, one of them, the "*Hale*," winning the second prize at the celebrated trial at Wilmington, Mass. The first prize being borne off by *Wilson Eddy's* 84-in. single driver, the "*Addison Gilmore*."

Shortly afterward Mr. Wilmarth built a number of engines for the Hudson River Railroad, with 78-in. drivers and outside cylinders, named after the various counties through which the road passed, the letters being placed on the side sheets of the tender and being about three feet high.

He built also a type which, since then, has become somewhat modernized, the *Agawam* for the Eastern road and the *Plymouth* for the Old Colony road, the drivers, four in number, and 54-in. diameter, being placed in the middle, and in front of the fire box, with a four-wheel truck in front, and a four-wheel trailer behind.

### Breakage of Rails.

When railways were first introduced for general traffic the iron rails used were fairly durable and carried a heavy tonnage of trains before they wore out. For a few years iron rails were honestly made of first class material, but by degrees the rail makers became weary of honest well-doing and proceeded to put profit before quality, so that the rails were notorious for breakages and for rapid wear. This moved the British Government to have appointed a special committee of the House of Commons to investigate the iron rail question. An expert rail maker testified before this committee that the first question asked him by the managing director of a rail making concern with which he was negotiating to take the position of superintendent was "how much slag can you work into a rail?" That policy of dishonesty more than the comparative weakness of iron hurried the steel rail into use. The number of broken steel rails now monthly found in the tracks of American railroads arouses the suspicion that steel makers have of late years adopted the policy of dishonesty

which brought to grief their predecessors, the makers of slag-loaded iron rails. The recurrence of breakage had become so serious that the New York Railroad Commission recently made a thorough investigation of the extent of the breakages complained of and they certainly have proved very serious. Steel rails have been steadily augmented in weight until the most popular dimensions are 100 pounds to the yard. This increase of weight was naturally entered into with the expectation that the heavy section would be stronger and less liable to breakage than the lighter rails, but the record shows that breakages of rails were never so common as they have been during the last three years.

The report says that 495 rails of 100-lb. section were broken and removed from the main line of the Lake Shore & Michigan Southern in New York State during the first three months of the current year, out of a total of 505 rails broken. Also that 475 100-lb. rails broke on the New York Central main lines east in New York within the same period, out of a total breakage of 477 rails. On the main line of the Mohawk division, 217 100-lb. rails broke in three months; on the western main lines (within New York State), 107 100-lb. rails broke. The total number of 100-lb. rails broken within the State in January, February and March was 1,295; a disgraceful record, for which the Steel Corporation is mainly responsible, as proved by the much lesser breakage of older rails, rolled according to specification. This deplorable condition may be due to different causes, but it is certain that a remedy must be found before the traveling public will use railroad trains with any sense of security or safety.

Railroad officials are inclined to blame the rail makers for the defects manifested, the charge being freely repeated that the heavy rails are not properly worked in the process of rolling and that defective parts of ingots are incorporated in the rails. There is little question that both these charges are well founded.

Meanwhile there has been too little consideration given to the changed conditions that exert a most destructive effect upon steel rails. The complaint is made that modern locomotives inflict great damage upon rails through the immense revolving blows of the driving wheels, but there is railroad rolling stock more destructive to rails than locomotives, when the entire effect of the wheel action is taken into consideration. The locomotive has been blamed through habit and repute for doing the greatest damage to tracks, but that was because no car approached it in weight of wheel impact. For the last ten years the heavy mineral cars have been steadily approaching the maximum wheel weight of locomotives, and weights are now common on car axles that were considered inadmissible

on the most powerful locomotives only a few years ago.

The modern coal car goes hammering over the track, each axle carrying a weight of 35,000 pounds, a most unresilient load carried mostly below the springs. Suppose a train containing 50 of these cars is going over a railroad at the best speed the locomotive can attain. The wheels constitute a protracted succession of hammer blows of unknown intensity. It is well known that when a rail, girder or other resisting structural member receiving a blow that approaches the elastic limit will recover its original strength if given time, which is the redeeming feature of track endurance. But if the blows are repeated at close intervals without time being given for recuperation, fracture will result. The locomotive with 40,000 pounds on a pair of driving wheels imparted very destructive blows to rails and bridges, but there was such long intervals between the blows that recuperation kept constantly remedying the damage done. There is no time for recuperation between the repeated blows of numerous heavy loaded trains and breakage of the rails is the result.

#### Fitting a Throttle Valve.

The balanced throttle valve has taken its proper place as one of the perfected attachments of the modern locomotive, and in point of constructive detail it admirably meets the requirements of the situation. It is a matter of regret, however, that so many leaky throttles are to be met with, and it is to be feared that few of our railroad machinists give the thought and attention to the grinding and adjusting of the throttle valve that they might do. Indeed it has been repeatedly observed that when locomotives are placed in the shop for general repairs the throttle valve will be found to be perfectly tight, the valve and seat having become fitted to each other by the mere force of attrition. After being refitted the valve will be found leaking. It would not be safe to assume that if the valve had been left alone it would have remained tight, as it is more than likely that the variations in the hardness of the metal in the valve seat had caused some degree of irregularity which the mere turning around of the valve would materially disturb.

It may be remarked that the throttle pipe or stand pipe as it is frequently called is of much greater thickness on the upper side, where it is attached to the brace in the dome than it is on the outer edge forming the rim of the valve seat. This variation in thickness of metal affects the wearing quality of the valve seat very materially. Such variation is more readily observed in the wear of cylinders where the thick walls are softer than the thinner walls of the cylinders.

Those who are familiar with the operation of boring out cylinders have no doubt observed the greater degree of wear of the thicker sides of the cylinders. In grinding a throttle valve it will be seen, after the first application of emery, that the wear has been greater on the thicker side of the valve seat, a portion of the bearing remaining untouched. In grinding the valve, particular care should be taken that the man doing the work does not remain in one position nor allow the valve to remain long in one position on the grinding spindle. The tendency to exert pressure other than in a vertical direction is very great, and the pernicious effect of this is obviated if the mechanic moves around the dome instead of seating himself fixedly in one place. The valve should be lifted after every few turns, and it is not necessary at any time to exert much weight upon the grinding spindle. Variations in pressure are also to be avoided, a steady, equable weight being less likely to create irregularities.

Some mechanics believe that the upper or larger bearing should be left somewhat lighter than the lower bearing, as the expansion must be greater in the case of a larger body of metal. It should be remembered, however, that this is also true of the bearing as well as the valve. The bearing will expand equally with the valve, so that allowance of this kind need not be seriously considered. Among the various tests as to the tightness of the joints after grinding, the air test, if convenient, is very simple and reliable. Chalk or pencil marks are also good tests if the valve be placed in proper position and slightly moved. If turned a complete revolution the test is of no value, as in making a revolution all the parts of the face of the valve will touch somewhere. It is well that from the beginning of the operation of fitting, the front and back of the valve should be definitely marked, as a change of position at any time materially affects the perfect fit of the faces.

Almost equal in importance to the careful grinding of the valve is the fitting of the throttle rod and attachments. We need hardly remark that it is the steam pressure that shuts the valve. The lever and rod should be so adjusted that when attached to the valve crank, the crank should strike the projection on the stand-pipe before the lever has reached the end of the rack. It is good practice to stop in the third or fourth notch from the end, as the accumulating lost motion arising from long service gradually brings the lever further toward the end of the rack or throttle lever quadrant. In this position the valve spindle should be fitted with a slight opening at the shoulder underneath as well as at the washer or nut or key on



the top. The amount of opening need not exceed ordinary thickness of paper, but it should be sufficient to avoid any possibility of the throttle rod tightening the valve spindle on the valve. It should be noted that the pins are all thoroughly fitted to the attachments and carefully kept in place by cotter pins. In conclusion it may be added that after completing the fitting of the throttle valve and its attachments, which should all be done by one skilled mechanic, thereby avoiding any divided responsibility, the throttle lever should be disconnected until the engine is ready to be fired up and move out of the shop. The tendency among unskilled railroad men and others who get up on an engine is to move the throttle lever out of mere curiosity, or otherwise. All engineers know how to open and shut a throttle valve, many others do not and they are often very careless about it.

#### Profits of British Railways.

The compiler of British statistics is slow but he is sure and his statement may be accepted as being correct enough for all practical purposes. The blue book of railways has lately been published and shows that the gross receipts from passenger and freight traffic last year on the British railways were \$625,000,000, an increase of only 1.3 per cent. These earnings include those of the electrified Metropolitan and Metropolitan District railways of London, the Liverpool Overhead railway and other lines of similar character in other cities.

The average dividends paid by the British railways were  $3\frac{1}{4}$  per cent. on the common,  $3\frac{1}{2}$  per cent. on the pre-



RAILROAD EXEMPLIFICATION OF THE FORMER AND THE LATTER DAYS.

ferred and 4 per cent. on the guaranteed stocks. On the loans 4 per cent. was paid and  $3\frac{1}{2}$  on the debenture stock.

The number of first class passengers increased by 1.1 per cent., and third class by 0.8 per cent., while second class decreased by 6.5 per cent., leaving a considerable net general decrease.

The receipts from excess luggage, mails, parcels, etc., show an increase of \$705,000. The total net earnings were \$213,300,000 on the \$6,415,000,000 capital, or 3.39 per cent., against 3.36 in 1904. There is therefore a slight increase here.

#### Increase in Railroad Equipment.

Until recently one of the striking features of the railroad situation passed almost unnoticed. This feature is the great increase in size and power of all railroad equipment. The passenger hurries to his place in a railway coach without a

of the shops, No. 2568, it appears to be a small engine.

The following is the relative size of the three types in use inside of thirty years: Total weight of engine C. P. Huntington, 20,000; Engine No. 1500 is 72,500; engine No. 2568 is 208,000; diameter of

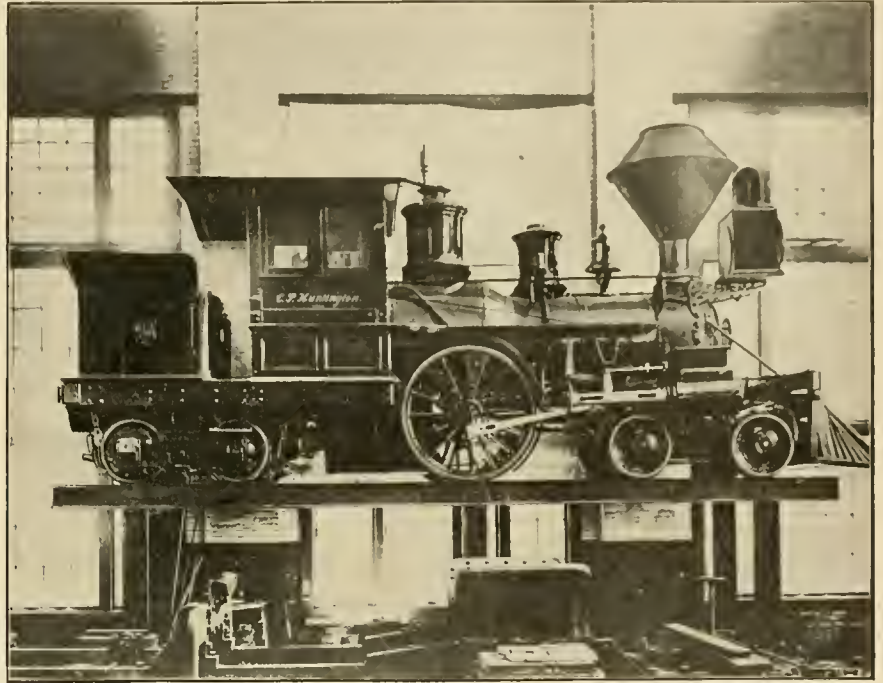

THE "C. P. HUNTINGTON," NOW AN EXHIBIT IN THE SACRAMENTO SHOPS.

thought of the dimensions of the modern car. He rarely stops to think how greatly it has outgrown its fellows of a quarter of a century ago. The freight car is more likely to be noted by the shipper; its greatly enlarged capacity may appeal to him more directly.

drivers are respectively 55, 63 and 57 ins.; cylinders, 11x15, 16x24 and 22x30 ins.; tractive power, 3,506, 11,600 and 43,305 lbs.; total heating surface of boilers, respectively, 419, 1,120, 3,430 sq. ft.; boiler pressure, 125, 140 and 200 lbs.

In providing for constantly increasing passenger traffic, additions to rolling stock and improvements in carrying capacity of coaches have been made steadily and rapidly. Our illustrations show the relative size of the old and the new passenger coaches: Car No. 80 was built in 1880, and the other in 1905. The seating capacity is seen to be more than doubled, and the weight of the coach in actual service is multiplied more than four times. This increased size provides for a large volume of travel and for the somewhat greater speed of modern days.

The ordinary size of freight cars in use twenty-five years ago looks diminutive beside those in use to-day. The carrying capacity in pounds is seen to be multiplied between three and four times and this is equivalent to the addition of a large number of the old-fashioned cars to the present-day stock.

A circular inch is the area of an arch one inch in diameter = .7854 ins. One square inch = 1.2732 circular inches.

Troy weight is used for weighing gold and silver. The grain is the same in troy, avoirdupois and apothecaries' weights.

The freight locomotive in use on the Harriman lines is the heavy consolidation. It is perhaps the best example of the wide departure from the old and well established design of past years. The old engine, "C. P. Huntington," retired and lifted to a place of honor in the Sacramento shops, is included in the list for the sake of comparison.

A later and greatly improved type is Number 1500, in point of size a great advance over its predecessors. It was provided for the valley traffic of California, and by comparison with the latest product

**Mechanical Engineers.**

Mr. T. H. Riches, President of the Institution of Mechanical Engineers of London, England, delivered an able address on the occasion of his election and made some pertinent remarks on the necessity of combining a thorough and sound theoretical knowledge with an equally sound training as a mechanic. No amount of purely theoretical knowledge, Mr. Riches

the river. The southern-most tube is farthest advanced, though the distances covered by all four are approximately the same. The meeting of the eastbound and westbound "headings" will be well to the east of the middle line of the river. Under Long Island City there is a stretch of 2,000 ft. of the four tubes, and in this stretch the excavation is practically all finished and nearly all the

engine shaft, he found it necessary to enlarge a hole which was drilled in the casing and which held the babbitt to the bearing. A pin from the cap fitted into the hole to prevent it from turning. In chipping out the hole to make it fit easy, the chips of course fell to the bottom, and as the pin would fit into the hole its full length, it was necessary that these chips be removed in some manner. To remove the babbitt casing would have made it necessary to block up the end of the shaft and remove the outer pillow block in order that the casing might be turned so that the chips would fall out of the hole. While I was wondering what process would be employed in removing the chips, the man procured a file and going to one of the generators which was in operation in the shop, magnetized the file. It was then an easy matter to remove the chips."



SOUTHERN PACIFIC FREIGHT CARS, OLD AND NEW.

claimed, can make a thoroughly satisfactory engineer, unless he has a sound knowledge of the technical details of work in the workshops, and every young engineer, if he intends to be an "engineer" at all, and a "mechanical engineer" in particular, should acquire a thorough workshop training coupled with study in theoretical work. It is the half-educated man in either one section or the other who finds a difficulty of progress.

Mr. Riches' remarks are pointed and true, and apply very aptly to many graduates of our mechanical engineering institutions, where there is not sufficient actual experience given in manual work to familiarize the student with the details of engineering construction. Many of our leading mechanical engineers in the chief railways in America have spent considerable time in the workshops and are in many ways fitted for their high calling, but this is the exception rather than the rule, and there is still room for improvement in the direction pointed out by Mr. Riches.

**Pennsylvania Tunnels at New York.**

Contracts for the only section of the Pennsylvania Railroad tunnels not already begun have been let. They are for building the eastern portals and the approaches, where the trains will come out of the ground in Long Island City, and a short stretch of cut-and-cover tunnel just west of the portals. This is the beginning of the open air tunnel work on Long Island. The excavation necessary for the construction of "Sunnyside yard" will be as great as that required for the terminal station in Manhattan.

Under the East River itself about half of the four iron-lined tunnels have been completed. Eight shields are being pushed forward, four from each side of

iron lining is in place. The work of concreting is now under way and is going ahead rapidly.

**Magnetic Chip Remover.**

The possibilities of electrically driven machines have not all been discovered yet. It frequently happens that the removal of filings or chips from holes has been very successfully accomplished by

**A Hero of the Right Kind.**

Mr. E. S. Weimer, ticket agent on the Chicago and Alton Railroad at Lemont, Ill., did noble work in saving a fast train during a terrific night storm. The heavy rains had flooded a distant bridge across which the train usually passes at a high rate of speed. Mr. Weimer made his way alone through the storm just in time to flag the train, which makes no stop at Lemont. When the train, which was



PASSENGER CARS TWO DECADES APART IN TIME.

the use of a pocket magnet. The magnet, however, is of use only when the casting or piece of metal cannot readily be turned over or moved.

Speaking of a clever magnetizing kink which he saw in a shop, Mr. J. Stephens, writing in the *Engineer's Review* says: "The other day I watched an erecting shop man setting up a new engine. In order that the outer bearing should not bind too tightly on the shoulder of the

full of passengers, was held up, it was found that the water had loosened the ties supporting the rails and later on, when the news was sent in, a wrecking crew was occupied a considerable time in fastening down and strengthening the structure before the train proceeded to Peoria. The passengers felt a glow of thankful satisfaction when they found out how dangerous had been their predicament.

# Correspondence School

## Fourth Series—Questions and Answers.

40—If valve is cut and blowing, can you locate the trouble?

A.—Yes. When the valve is cut and blowing there is a constant leakage of steam on the side of the engine with the cut valve. If the valve be placed on the centre, so that both ports are covered, steam will issue from both cylinder cocks.

41—And which side it is on?

A.—The side on which the trouble lies can be ascertained by placing the valve on one side of the engine on its centre and observing the flow of steam from the cylinder cocks, and then testing the other side in a similar manner.

42—Will steam come into cylinder if valve is tight and stands in the middle of its travel—that is, covering both steam ports?

A.—No.

43—Can you locate the trouble if the steam pipe is leaking? How?

A.—Yes, if the steam pipe is leaking steam will blow from the leak into the smoke box and so up the stack. This leak can be ascertained by opening the smoke-box door.

44—If exhaust gets out of square on the trip, what does it indicate?

A.—It indicates that the exhaust pipe joint has worked loose or tip is loose.

45—Can you locate the trouble, whether it is a slipped eccentric, loose bolts in the strap, eccentric rod loose on the strap, or broken valve yoke? How?

A.—A slipped eccentric will cause the valve to travel improperly with respect to the piston, and if badly out of position will make the engine work against itself so much as to prevent starting in certain positions. The incorrect position of the eccentric usually can be detected by inspection. If the eccentric strap bolts are loose the valve travel will show excessive lost motion, and inspection will probably reveal the loose bolts. The eccentric rod loose on the strap will show excessive lost motion and will be found by close inspection. A broken valve yoke will show by the valve being pushed over to the forward end of its stroke and not returning if the yoke is broken close to the stem, or if broken on both ends of the valve. If broken on one side the springing of the yoke will cause the

valve to be late in travel, like that caused by excessive lost motion, and if the inspection of the valve gear shows it to be all right, the broken yoke can then be looked for.

46—Is there anything else not mentioned that would effect the sound of the exhaust?

A.—Yes, if there was excessive lost motion in the valve gear, or if the exhaust edge of the valve was broken, or if there was a leak past the balance strips of the valve.

47—Can you set a slipped eccentric? How?

A.—Yes. This can be done approximately. If, for example, the right forward eccentric had slipped the position of the right, back up eccentric might be



OLD "BIRKENHEAD" ENGINE USED ON THE C. & G. RAILWAY. IT WAS A FREIGHT ENGINE ON THE GRAND TRUNK IN 1845.

noticed, and the right forward eccentric placed at about the same angle with the crank as the right backing eccentric makes, only the right forward one must be placed on the other side of the centre line of the crank from the right backing eccentric. Another way is to set the engine so that the right back up eccentric is in such a position, with the reverse lever in the back corner, to have the valve with full back up lead open. Then mark the valve stem and place the reverse lever in the front corner and move the slipped right forward eccentric so that the mark on the valve stem comes to where it was. Or, use the keyways in axle and eccentric as a guide and make them coincide.

48—How do you tell which eccentric has slipped?

A.—This can be done by intelligent inspection.

49—How are they kept in their places on the axle?

A.—Eccentrics are usually kept in their places by keys and set-screws.

50—How do you get the engine on the exact centre?

A.—Place the engine near the end of its stroke and scribe a line on cross-head and guide. Take a trammel and with one point on a centre punch-mark on frame, scribe a line on the tire with the other end of the trammel, then move the engine to end of its stroke and back until crosshead line, and line on guide coincide again. Mark a second point on tire of wheel as before. You have now two points on tire. Divide the distance equally between them, and with one end of trammel point in the centre punch mark on the frame, move the engine until the other end of the trammel comes to the newly found midway point on the tire. If you have done this toward forward end of stroke, you have found the forward centre.

51—Which centre is most convenient to set eccentric from?

A.—The forward centre usually.

52—Where do the eccentrics come in relation to the crank pin on that side of engine?

A.—For an outside admission valve, piston or D-slide, with indirect valve motion, the bulge of the eccentrics will stand so that they are on the same side of the vertical centre-line through the axle, as the crank pin is. An

illustration may be given by supposing that the main crank pin is on the forward centre, or at the figure 3 in the dial of a watch. The vertical line would pass through 12 and 6, and the centre of the bulges or larger parts of the eccentric would be about 1 and 5. If on the forward centre, on the right side, the go-ahead eccentric will be above the crank pin and the back-up eccentric below it. This will also be the position with inside admission and direct motion, only the go-ahead eccentric will be below the crank and the back-up above it. With inside admission valves and indirect motion, and with outside admission and direct motion, the bulges of the eccentrics will lie on that side of the vertical centre line which is remote from the crank pin.

53—Where do they come in relation to the eccentrics for the same motion on the other side of the engine?

A.—The answer to this question is practically included in the answer to question No. 52.

54—What generally causes eccentrics to slip?

A.—Keys slacking and dropping out and the set screws becoming loose.

55—How do you move the eccentric back to its proper place on the axle?

A.—By moving it so that the key ways in eccentric and axle coincide.

56—Would you put water on a very hot eccentric or strap?

A.—No; there would be danger of causing the eccentric strap to crack.

57—Are all eccentrics made in one piece?

A.—No. They are generally made in two pieces.

58—What do you disconnect, take off and block up in case of a broken eccentric or strap?

A.—You disconnect and take off the eccentric strap and eccentric rod. Disconnect and take down the valve rod and move the valve to its central position and block it there.

59—Can an engine be worked ahead to a station with a full train if back motion strap is broken?

A.—Yes, it is possible.

60—If link hanger or pin is broken?

A.—No.

61—If arm is broken off tumbling shaft?

A.—No. This would require blocking up the link and full train might be difficult to start. The answer to this depends very largely on local conditions.

62—With broken reach rod?

A.—Yes.

63—With broken link-block pin?

A.—No.

64—With broken piston gland or stud?

A.—Yes.

65—What would you do with an engine with broken piston?

A.—Disconnect butt end of main rod, push the main rod, crosshead and piston ahead and block crosshead; let the main rod rest in guide yoke, taking care to see that main pin clears end of connecting rod. Take down valve rod, place valve in its central position and block it there.

## Elements of Physical Science.

### III.—LAWS OF MOTION.

The generic principles in the laws of motion are two important factors, one being that a body at rest remains at rest, a body in motion moves in a straight line with uniform velocity, unless acted on by some external force. No body has power of itself to move or to cease moving if in motion, or to change its direction or its velocity.

It will be observed that with the exception of falling bodies, all other bodies

in motion move in curves. This is in consequence of their being acted on by other forces besides those that set them in motion. The tendency of all moving bodies, however, is always to continue in a straight line, even when from over-ruling causes it moves in a circle. Throwing a stone from a sling is a good illustration of this law. The force which tends to make a body fly from the center round which it revolves is called the centrifugal force. The opposite force, which draws a body towards the center round which it revolves is called the centripetal force.

Magnificent examples of these two forces are exhibited by the planets revolving around the sun. In obedience to centrifugal force, they tend to fly off into space in a straight line. This tendency is checked or balanced by a centripetal force equally powerful. The attraction of the sun is such that the planets are restrained in their force, with the result that they revolve in curves which keep them moving in a perpetual circle.

To counteract the effects of the centrifugal force in curves on railroads, the outer rail is laid higher than the inner one. Were it not for this precaution, trains moving swiftly round a curve would be thrown from the track. It may be stated in this connection that a certain amount of elevation of the outer rail is adapted to a certain amount of velocity, and it is of importance that trains moving on curves should do so at the velocity for which the elevation of the outer rail is adapted. Several terrible disasters both in Great Britain and America have occurred in recent years by disregarding this necessary precaution. The higher the rate of velocity of the moving train, the higher should be the outer rail. The running of a horse round a circle is an illustration of how instinct teaches the lower animals the necessity of leaning to the inner side in running in a curved line. The circus-rider will also be observed to lean farther inward as the speed of the horse increases.

### LAW OF CENTRIFUGAL FORCE.

The centrifugal force of a revolving body increases in a ratio to the square of the velocity. If one body moves twice as fast as another, its centrifugal force would be four times as great; if three times as fast, nine as great; if four times as fast, sixteen as great; and so on. It will be readily observed that in the act of whirling a stone around as in a sling, the tendency to break the cord is greater under a rapid motion than a slow one.

It will be noted that centrifugal force acts not only on bodies moving in curves, but also on fixed bodies revolving on their own axes. In the case of large wheels being turned rapidly, the centrifugal force at the circumference becomes an agent of great power. If such wheels are not made of strong materials, their cohesive quality will be overcome by the cen-

trifugal force, and they will break into pieces. Grinding stones of emery and other substances deficient in cohesion have frequently burst with very disastrous results.

In the case of bodies revolving on their own axes, all parts having to complete their revolution in the same time, and as we have seen that the centrifugal force increases with the square of the velocity, and it being necessary that the farther from the axis the parts are such parts have a greater distance to go, and must necessarily move faster, therefore the centrifugal force is stronger at the outer edge than at any other part of the revolving body. In revolving spheres, the centrifugal force is greatest at the equator, and diminishes from that point till at the poles it disappears.

### ACTION AND REACTION.

Action is the force which one body exerts on another subjected to its operation.

Reaction is the counter-force which the body acted upon exerts on the body acting. Reaction is always equal to action, and opposite to it in direction. In the discharging of a gun, the exploding powder carries forward the ball, but the blow struck on the shoulder of the person firing the gun is the equivalent of the force that carries the ball.

Action is often nullified by reaction. A man rigged a luge bellows in the stern of a sailboat in order to raise wind. The reaction on the bellows by the air was such that the boat would not move. A similar case was that of the man who tried to raise himself over a fence by pulling at the straps of his boots. The upward impulse was exactly counterbalanced by the downward impulse.

Action and reaction are equal, but are exhibited differently in non-elastic and elastic bodies. This is shown in the case of a non-elastic ball striking a ball of similar structure. Both bodies will move in the direction struck half the distance that the striking ball would have moved if unimpeded. If the two balls be of ivory, or other highly elastic substance, the striking ball will impart its motion to the one at rest and remain stationary after striking, while the ball struck will move the same distance as the striking ball would have reached if unresisted.

Reflected motion is the motion of a body turned from its course by the reaction of another body against which it strikes. The angle made by the body in its forward course with the perpendicular at the point of contact is called the angle of incidence. The angle made by the body in its backward course is called the angle of reflection. The angle of reflection is always equal to the angle of incidence. A ball may be thrown to the ground at various angles. The lines of recoil always form the same angles as those formed by the lines of projection.

## Questions Answered

### CRITICAL HEAT OF STEEL.

(58) F. D. M., Houston, Tex., asks: In what ratio does the tensile strength of plate decrease as per degrees of heat are applied? A.—There is no very comprehensive data as to the gradual decrease of tensile strength of a boiler plate as it gets hotter. We would advise you to read an article on the "Critical Heat of Steel" on page 261 of the June, 1904, issue of RAILWAY AND LOCOMOTIVE ENGINEERING.

### RE-STARTING INJECTORS.

(59) A. J. B., Warren, Ark., asks why does the "simplex" injector have such

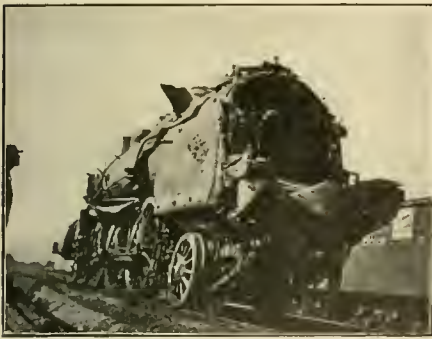

RESULT OF DEFECTIVE TRACK.

a large overflow pipe? I have been asked by several engineers but could not answer them. A.—The Simplex injector is one of the re-starting type. That is, it is an injector which is capable of starting automatically after it has been stopped, by an interruption of the water supply, and then water flowing again. Other injectors of the ordinary kind would, under these circumstances, have to be closed down and started again by hand. The re-starting injector is intended to act when steam and water come together suddenly in the same volume of flow as they were when the injector was working. To do this, and to enable the injector to pick up the water or re-start automatically it is necessary when the flow of water is interrupted to give the steam a ready outlet to the atmosphere, since otherwise a pressure would be created within the overflow chamber which would impede the flow of water and the injector could not be made to re-start automatically. For this reason re-starting injectors require a much larger overflow valve, larger overflow casing, and overflow pipe than ordinary injectors. This is why these parts differ in size from those on injectors not possessed of the re-starting quality.

### BY-PASS VALVES.

(60) J. A., New Haven, Conn., writes: What is the use of a by-pass valve, and how do some engines get

along without such valves? A.—Some form of by-pass valve is used for relieving the pressure caused by the piston when it approaches the end of the stroke and the exhaust is shut and when a greater degree of compression arises than the initial pressure of steam may amount to, in which case the by-pass valve is raised from its seat and the compressed steam is forced back into the steam chamber, thereby relieving the cylinder head and piston from excessive pressure. This by-pass valve is used on engines furnished with the piston valve. It is not necessary on an engine furnished with the ordinary slide valve, as in the event of the pressure in the cylinder being greater than in the steam chest the slide valve will lift sufficiently to relieve the pressure.

### SUPERHEATED STEAM.

(61) W. A. McR., Whitefish, writes: We have had a good deal of discussion about superheated steam here, and I would be glad if you could enlighten us about the benefits, if any. Does it give a higher pressure? A.—Superheating does not raise the pressure. By superheating the steam at or near its admission into the cylinder it is able to stand the inevitable heat losses, due to condensation without reducing its efficiency in the cylinder, because the superheated steam has a reserve of heat to draw upon and its range of expansion is greater than ordinary saturated steam at the same pressure. Experiments have repeatedly demonstrated that there is a gain in efficiency of from between 10 and 15 per cent.

### MUD RING LEAKING.

(62) R. W., Calgary, Canada, writes: I have noticed that the mud ring leaked much more during the winter than at present. Our boilers are washed out regularly. How is the variation accounted for? A.—Many of the smaller leaks on locomotive boilers are caused by variation in temperature, which causes extreme contraction and expansion. The thin boiler sheets contract much more rapidly in extreme cold weather than the mud ring, which is of considerable thickness. Hence the tendency to leak around the mud ring is much greater in winter than in summer. The engine is subjected to harder usage all round in winter than it is in summer.

### VALVE LAP.

(63) J. G. M., Richmond, Va., writes: What is meant by "lap" on a valve, and what is the purpose of a valve having "lap?" A.—Lap is that portion of a steam valve that overlaps or covers the steam ports when the valve is on its centre, and if the valves were made to cover the ports exactly and no more, the result would be that as soon

as the admission of steam was closed, if the valve continued to move, the other port would be opened, with the result that the steam could not be worked expansively. Without lap on the valve the loss of steam would be very great. The lap on a valve allows of the admission of a certain amount of steam, then both ports can be closed, and the amount of confined steam has an opportunity to move the piston a considerable distance, thereby not only effecting a saving in the amount of steam used, but also reducing it to a low pressure before being released.

### Rail Expansion.

An interesting case of a railway accident occurring at Felling, England, has been reported upon by the British Board of Trade, wherein a "kink" in the rails was the cause of a locomotive and cars leaving the track. The circumstances were remarkable from the fact that the driver of a steam roller, who saw the kink in the rails, ran to a signal box and gave notice to the signal man, who coolly replied that the train would have to come on now, and took no steps to stop the train. The signals being "off," and the engineer on the oncoming train not seeing the kink in the rails, came on, and it was fortunate that the accident was not of a more serious nature.

It is said that the official report states the cause as "the heat of the sun." This looks to us like going a long distance for causes. Doubtless the members of the Board of Trade are aware that on all inclines, especially where the brakes



TO THE SHOP FOR REPAIRS.

are frequently applied, the rails creep down the grade and the expansion spaces left between the rails at the foot of the incline are gradually reduced. It is part of the work of the maintenance of way department to see to it that the proper amount of expansion spaces are always maintained. It is evident that in this particular case the duty was neglected. Doubtless the increasing warmth of the atmosphere was the final cause of the bending of the rail, but this was only one of a chain of causes, all of which could have been foreseen and the accident avoided.

# Patent Office Department

**REVERSING MECHANISM.**

A reversing mechanism for locomotives has been patented by Mr. C. J. Mellin, Schenectady, N. Y., No. 852,445. The device embraces the combination

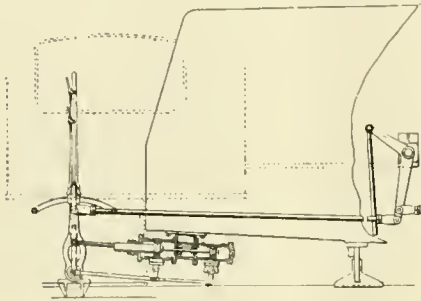

REVERSING DEVICE.

of a main reverse lever journaled to move about a pivotal axis, with means for connecting the lever to a valve actuating mechanism, a fluid pressure motor adapted to impart movement to the main reverse lever, an operating reverse lever journaled to move about a pivotal axis, and means for mechanically connecting the main and operating reverse levers. There are also means for supplying and exhausting motive fluid to and from the motor in and by the movements of the operating reverse lever.

**PISTON-RING EXPANDER.**

Mr. O. Winter, Elyria, Ohio, has secured a patent on a piston-ring expander, No. 855,031. As shown in the illustration the tool includes pivotally united jaws, one jaw being provided with a locking pin, and a locking member pivotally

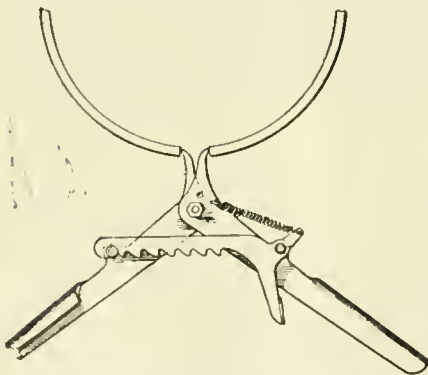

EXPANDER FOR PISTON RINGS.

mounted on the opposite jaw and provided with spaced teeth adapted to engage the locking pin for holding the jaws in adjusted position. There is also a spring for yieldably supporting

the locking member in engagement with the pin, and a finger piece carried by the locking member for moving the same to released position.

**LOCOMOTIVE.**

Mr. Carl J. Mellen, Schenectady, N. Y., has patented an improved locomotive, No. 852,444. As shown in the accompanying illustration, the combination embraces a rear frame, a front frame of bar form pivotally connected to the rear frame, wheels journaled in bearings in both sets of frames, a boiler rigidly connected to the rear frame, a spring casing secured to the boiler with the capacity of independent lateral movement. Vertical connecting bolts pass through and fit freely in a

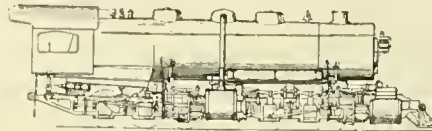

IMPROVED LOCOMOTIVE.

rail of the rear frame, and in a rail of the front frame. There is also a reversing shaft journaled in bearings below the foot plate, a reverse lever, with reversing arms on the ends of the shaft, two lifting levers for actuating the valve mechanism, and reach rods connecting the reversing arms and lifting levers. The various new devices admit of locomotive construction embracing greater strength than anything hitherto constructed and also a greater degree of flexibility.

**STEAM-TURBINE LOCOMOTIVE.**

Mr. J. Stumpf, Charlottenburg, Germany, has patented a locomotive with

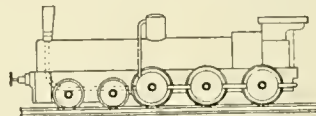

TURBINE ENGINE.

steam-turbine drive, No. 855,436. The device takes the form of a locomotive with axles and driving wheels mounted on the ends of the axles, a turbine adjacent each wheel, means for passing steam in series through the turbines on one side of the locomotive, and also for passing it in the opposite direction through the turbines on the other side of the locomotive, so that the pairs of driving wheels are uniformly driven by a pair of turbines connected with the axle of each pair of wheels and receiving motive fluid at variable pressures.

**OIL BURNER.**

An oil-burner has been patented by Mr. G. Larsen, San Leandro, Cal., No. 855,857. The device embraces the com-

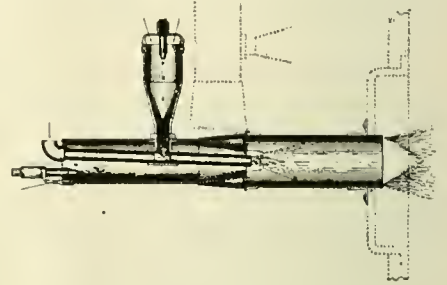

SPRAYER AND MIXER FOR OIL.

ination of an air pipe open at the ends, provided with a reduced nozzle portion at its front end, an oil pipe open at both ends disposed within the air pipe and inclined slightly downward and forward, the oil pipe having its front end substantially flush and concentric with the nozzle of the air pipe, the oil pipe having an oil inlet between its ends, and means for admitting air under pressure into the air pipe to induce a current of air through the oil pipe.

**LOCOMOTIVE DIAPHRAGM.**

Mr. G. L. Prentiss, Montclair, N. J., has patented an improved locomotive diaphragm. No. 849,496. The device consists of a diaphragm interposed between the boiler and the exhaust flue, the diaphragm being provided with openings which are located through the

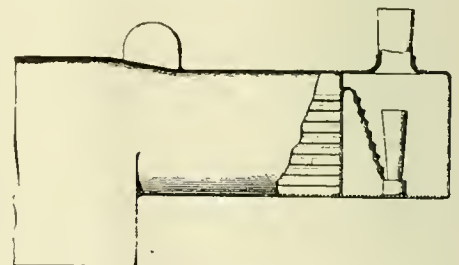

DIAPHRAGM FOR SMOKE BOX.

entire area of the diaphragm, and a series of independent dampers, one for each opening, pivoted to the diaphragm. The dampers are adapted to permanently open or close one of the openings whereby the draft can be caused to pass through the diaphragm at any portion of its area.

# Air Brake Department

## Air Brake Convention.

At the recent annual convention of the Air Brake Men's Association at Columbus, Ohio, the second day opened with a paper entitled "Brake Shoe Friction With Brake Hanger at Various Angles." It was read by its author, Mr. John S. Barnes. It recounted a list of interesting experiments made in applying a brake shoe to a rapidly revolving 30-in. cast iron wheel. After a brief discussion, the paper on "Maximum Allowance of Brake Pipe Leakage" was read by Mr. M. H. Laylin, the author. The discussion was opened by Mr.

A brief discussion followed touching on the points treated of in the paper and this brought out the fact that there is a big difference in the kinds of hose gaskets furnished by the various manufacturers and by the air brake companies.

The paper on "Recommended Practice" was then read in abstract by the chairman of the committee on this subject, Mr. S. G. Down, and it occupied the attention of the members for the rest of the day.

This paper is perhaps one of the most important which the association has

Draper's absence the paper was read by Mr. F. B. Farmer. After a brief discussion touching upon the use of compressed air for water-raising systems, bell ringers, sanders, simpling devices for compound locomotives, et cetera, the paper on "Hand Brakes for Freight and Passenger Cars on Mountain Grade Service," by Mr. Mark Purcell, chairman of the committee on this subject, was read by Mr. F. B. Farmer.

The discussion which followed brought out the fact that the brake beam release spring was often responsible for poor hand brakes, as well as many



AIR BRAKE CONVENTION, COLUMBUS, OHIO. MEMBERS IN ATTENDANCE.

W. C. Hunter, and about all the causes imaginable of brake pipe leakage were brought out by the members participating. The pulling apart of hose and the poor fit of the hose gaskets were among the leading causes cited of brake pipe leakage, while in very cold climates the rigidity of the hose contributed very largely to the trouble.

Then came Mr. C. B. Conger on the "Hose Coupling," which made a strong plea for a better hand method of hose coupling. It also brought out the startling fact that the practice of pulling hose apart when parting cars costs some of our large systems about thirty dollars per year per car, because of the damage to hose alone, not to speak of the annoyances such a practice brings about in the way of increased brake pipe leakage. The paper recommended the designing and adoption of a hand coupling that will pull apart without damage to the hose.

had to deal with, and it touches on all matters of importance concerning installation and maintenance of air brakes on both locomotives and cars. This report was adopted as a whole by letter ballot, but quite a lengthy discussion was provoked in settling some of the points which required revision. The committee on this subject was continued for another year, after which discussion closed, and adjournment was taken until the next morning at 9 o'clock.

Immediately after coming to order on the third day, it was voted to continue the committee on the subject "Breaking in Two of Long Passenger Trains" for another year, and to have them report at the 1908 convention. A paper on the New York B2 equipment was then read, and this was followed by one by Mr. S. H. Draper on the subject "Air Drawn from Brake System to Operate Air Using Devices." Because of Mr.

other troubles with brakes and that they materially reduced the braking power.

During the discussion considerable thought was given to the advisability of having good hand brakes for mountain grades.

Before adjournment, which was taken at 1 P. M., it was voted to hold a session on Friday in order to finish the large amount of business which came before the convention this year.

After luncheon there was a general visit by the members to the air brake instruction cars, which were standing on the side track at the union station. There were four of these cars on exhibition, one each from the Pennsylvania, the Lake Shore and Michigan Southern, the Big Four and the Hocking Valley railroads. These cars were fitted with passenger and freight brake equipments, all piped up so as to be operated from a brake valve, and they

were arranged in the cars so that the classes could easily observe the effects of variations in air pressure, and of differences in piston travel. In addition to the complete car equipments, they were furnished with air signal equipments, models and sectional parts of valves, colored charts, and apparatus showing the various defects, all of which are highly useful for instruction purposes.

These cars, aside from their value as instruction plants, were very much admired for the ingenious and clever manner in which the immense amount of material and piping they contained was arranged in the comparatively small space available, and yet leave sufficient room for the classes. They were in charge of the various instructors from the roads represented,

Equipments for All Classes of Freight Brakes." In this paper the author favored the detached type of freight equipment, claiming that his experience showed that cylinder gaskets could be kept in much better condition with the detached than with the combined type.

A paper on the subject "A Standard Form of Defect Card" was read by Mr. W. C. Hunter, chairman of the committee on this subject.

This paper brought out considerable discussion, but no definite conclusions were reached and the committee was continued for another year. There is little doubt, however, but that this committee has an important work in hand, and they will eventually devise a scheme for running down defects and checking repairs that will be of immense help to the railroads.

of business and hard work, with but little time devoted to sightseeing, and it was also one of the very successful conventions with respect to the number of members attending and the method in which its business was handled.

The presiding officer, Mr. W. P. Garrabrant, deserves much credit for the efficient and satisfactory manner in which he discharged the duties of his position. He certainly was "all right." At noon the convention adjourned to meet in 1908 at the city to be determined later by the executive committee, after they shall have received the suggestions of the members as to the most desirable place.

#### Retaining Valve Piping.

From now on there will be no question of a sufficient number of air brakes on any freight train to control its motion on levels and on heavy grades if only these brakes are maintained in average serviceable condition. Too often in the past the piping of the brake apparatus on the cars has not been what it should be, and the condition of the piping of the pressure retaining valves, especially on level roads, has been considered something that could be entirely ignored without detriment. Lately there appears to be an active interest manifested on roads having heavy grades, in the handling of trains on the grades entirely with air brakes, and thus interest bids fair to turn attention to the pressure retaining valve and its maintenance, more than has heretofore been customary.

When the number of tons which can be safely handled down grades with the use of air brakes is shown beyond all doubt to exceed that which can be handled with hand brakes, which is the case, and at the same time that the wheels in no case are heated to anywhere near the temperature they are by the hand brakes, railroad officials commence to "sit up and take notice," for this is just what they want to do.

That this can be done in heavy grade service has been demonstrated during the past two years on several roads that formerly depended on the hand brakes, and it has also been learned by them that the wrecks, due to overheated and cracked wheels, had during hand brake control, were entirely eliminated.

In the accomplishment of these desirable results the pressure retainer, properly used, is a most important factor, and, therefore, the maintenance of its pipe connections free from leakage is something that should be carefully looked after.

The pressure retainer, well maintained, will more than repay the cost many times over in the saving to wheels alone, not to speak of the greater number of cars that can be handled with increased safety.



LADY FRIENDS OF THE DELEGATES AT THE AIR-BRAKE CONVENTION, COLUMBUS, OHIO.

and these gentlemen showed the members every courtesy during their visit.

The first paper of Friday's session was one by Mr. S. W. Dudley on the "Electrification of New York City Terminal of the N. Y. C. & H. R. R. R.," and it was read in abstract by the author.

This paper dealt with the use of Westinghouse automatic air brakes in connection with electric trains. On account of the comparative newness of this equipment, the discussion was brief, but there is little doubt that in future conventions this same subject will come up for careful consideration. Much credit is due the author of the paper for the clear and thorough method with which he handled the subject.

A short paper by Otto Best followed on "Detached versus Combined Freight

The closing work of the convention was the election of the following officers for the ensuing year:

President, Geo. R. Parker.

First Vice-President, P. J. Langan.

Second Vice-President, W. C. Hunter.

Third Vice-President, John R. Alexander.

Secretary, F. M. Nellis.

Treasurer, Otto Best.

Executive Committee, W. P. Huntley, H. A. Wahlert, W. J. Hatch.

A large display of exhibits was shown at the convention this year, among them being packings for steam heat by the Johns-Manville Co., steam heat couplings and hose by the Consolidated Car Heating Co., valves and gauges by the Ashton Valve Co., Palmetto packings for air pump, Dixon's graphite, McLaughlin flexible conduits.

The convention was almost entirely one



# Electrical Department

## Motors for Railway Service.

If the belt connecting an engine or a motor to the machinery which it is driving should be cut on each side of the driving pulley and a spring balance inserted in each place, as long as the machinery was standing still, both balances

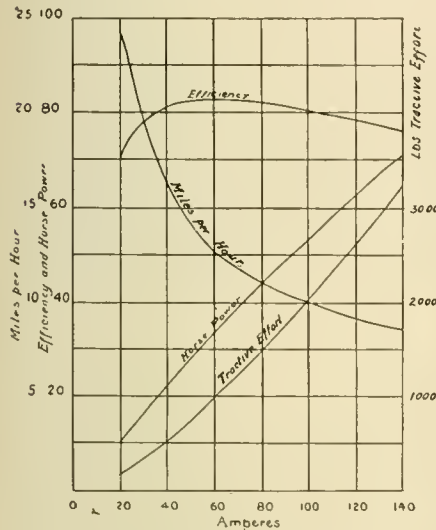

FIG. 1. CHARACTERISTIC CURVES OF 40 H. P. RAILWAY MOTOR.

would read alike. If it were possible to run the engine or motor with the balances still in place, it would be found on starting up that the reading of the balance on the side of the belt traveling toward the driving pulley would increase, while that of the balance on the side traveling away from the pulley would decrease. The difference of the readings of the two balances is evidently the pull which is being exerted by the engine or motor at the rim of the driving pulley. This difference, in pounds, multiplied by the speed in feet per minute at which the belt is traveling gives the foot pounds of work which is being done, and dividing this product by 33,000 the output in horse power is obtained.

If a motor is running at a constant speed and developing a constant horse power output, the pull exerted at the rim of the driving pulley depends on the diameter of this pulley. For, since the speed of the belt is practically the same as that of the rim of the pulley (unless the belt is slipping) with a constant speed of the shaft, the speed of the belt will be fast with a large pulley and slow with a small one. Hence, in order that the horse power may be constant, the pull must be the opposite of this, or small with the large pulley and large with the small one.

In stating the pull which a motor can exert, a pulley two feet in diameter (or having a radius of one foot) is taken as the standard, and the pull which a motor can exert at the rim of such a pulley is called its torque.

The speed of a belt running over a pulley two feet in diameter is so related to the speed of the shaft in revolutions per minute that, the torque multiplied by the revolutions per minute and divided by 5,250 is equal to the horse power developed. Thus the work which is being done depends on both the torque and the speed.

In dealing with railway motors it is particularly important that the difference between torque and horse power as de-

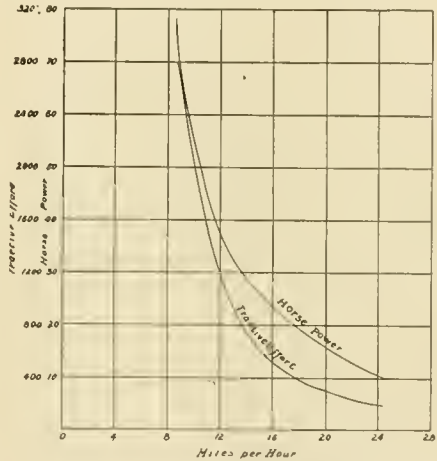

FIG. 2. TRACTIVE EFFORT AND HORSE POWER.

scribed above should be clearly grasped, and the fact that a motor may exert a large torque without developing a large horse power, be thoroughly understood.

For railway service the motors are connected to the wheels and axles of the car or locomotive, either directly or by means of a gear and pinion, and one is usually concerned with the pull at the rim of the driving wheels rather than with the torque. If the motor is connected directly to the axle or wheels, then the pull at the rim of the wheels is to the torque as 24 in. is to the diameter of the wheels. That is, with a 36-in. wheel, the pull at the rim is  $\frac{24}{36}$ , or  $\frac{2}{3}$  of the torque. If the motor is connected to the axle by means of a gear and pinion, then the ratio of these must be considered as well as the diameter of the wheel. In this case the pull at the rim of the wheel is equal to

$$\frac{\text{No. of teeth in gear}}{\text{No. of teeth in pinion}} \times \frac{\text{dia. of wheel in in.}}{\text{efficiency of gears}} \times \text{torque}$$

The efficiency of the gears varies somewhat, according to the speed, load, etc., but can usually be taken as about 95 per cent.

Thus, if a motor having a torque of 500 lbs. at full load is mounted on an axle having wheels 33 in. in diameter and is connected to the axle by means of a 20-tooth pinion on the motor shaft and a 61-tooth gear on the axle, the tractive effort exerted at the rim of the wheels will be

$$\frac{61}{20} \times .95 \times 500 = 1,052 \text{ lbs.}$$

This pull which a motor exerts at the rim of the car wheels to which it is connected is called its tractive effort. It will be evident from the above that the tractive effort is proportional to the torque.

The relation between the speed of the motor shaft and the speed of the car which it is driving also depends upon the number of teeth in the pinion and gear and the diameter of the car wheels. The speed of the car in miles per hour is equal to

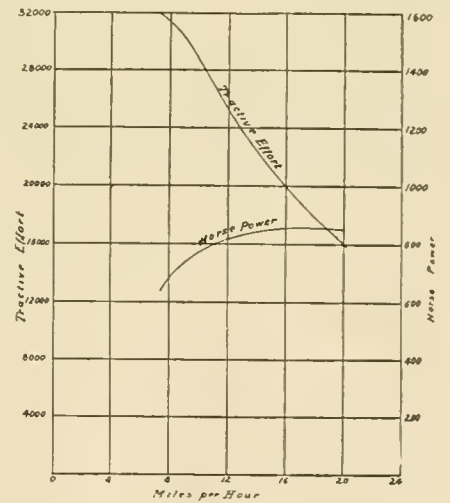

FIG. 3. CURVES OF 97-TON FREIGHT LOCOMOTIVE.

$$\frac{\text{No. of teeth in pinion}}{\text{No. of teeth in gear}} \times 3.14 \times \text{diam. of wheel in feet} \times \frac{\text{revs. per minute of shaft}}{5280}$$

When a motor-driven car or locomotive is hauling a trailing load, a certain part of the tractive effort developed by the

motors is used up in propelling the car or locomotive itself and the remainder appears at the draw-bar and is used in pulling the trailing load. The latter is called the *draw-bar pull*. The difference between tractive effort and draw-bar pull is not a constant, but depends upon the grade, speed and condition of track over which the train is being hauled, because the force necessary to move the locomotive itself depends upon these factors.

Electric motors which are used for railway service are practically always of the series wound type. Motors of this type do not run at a constant speed, as do the motors ordinarily used for driving machinery, but the speed of the motor varies widely with the load. The relation between the speed, torque and horse power output of such a motor is usually shown by means of a set of curves which are called the *characteristic curves* of the mo-

tor, as in Fig. 1, they may be plotted in terms of miles per hour, as in Fig. 2, which is more convenient for certain purposes, or they could be plotted in other ways.

The tractive effort required to move a car or train on a grade may be very much greater than that on a level. It will be seen from Fig. 2 that the series motor is well adapted to such conditions, since by slowing down in speed it can develop a much greater tractive effort without increasing the horse power in anything like the same proportion. Thus, when running at 20 miles per hour, the motor develops 16 H. P. and 300 lbs. tractive effort. If 700 lbs. tractive effort is suddenly required, the motor slows down to 13½ miles per hour and produces the required tractive effort of double its former value, while developing only 28½ H. P., or about 1¾ times as much.

power output has fallen to 745. In the case of the motor, however, the tractive effort at 18 miles per hour is 395 and 19 horse power is developed, while at nine miles per hour the tractive effort is 2,600 lbs., or over six times as much, because the horse power, instead of falling off, has increased to 62½. This feature of the series motor—being able to develop very large tractive efforts when required—gives it a great advantage over the steam locomotive under certain conditions, and is the reason why this type of motor is used for electric traction.

#### London's Latest Tube.

London's first "tube" railway (the City and South London) was opened in December, 1890, and was followed in August, 1898, by the Waterloo and City, and in July, 1900, by the Central London. Meanwhile several further piecemeal schemes had received Parliamentary sanction; but no attempt to deal with the problem on anything like comprehensive lines was made until the late Mr. C. T. Yerkes entered the field early in 1901. The Great Northern, Piccadilly and Brompton Electric Tube Railway is the latest outcome of the energetic action of Mr. Yerkes and his associates.

The "Piccadilly" tube forms part of a series of three similar railways which, in conjunction with the electrification of the old Metropolitan District system and the laying down of the extensive network of West London electric tramways all owe their being to the genius of Sir Clifton Robinson. The first of these three tubes, the Baker Street and Waterloo ("Bakerloo") was opened not long ago; the third, the Charing Cross, Euston and Hampstead, will follow.

The track is double throughout the entire length of 9.32 miles. Each of the two roads is laid in a separate circular tunnel, the diameter of which varies from 11 ft. 8 ins. on the straight to 12 ft. 6 ins. on the sharpest curves; at the 22 stations the tunnels are expanded to a diameter of 21 ft. 2½ ins. They have been driven through the London clay and are lined throughout with cast-iron segments; the depth from the street surface to platform level at the various stations ranges from 20 to 120 ft. There are five single and two double cross-over roads, distributed at suitable portions of the line. For the greater portion of the route the tunnels are placed side by side, with an island platform between them at the stations; but in some cases, owing to the narrowness of the street above, it has been found necessary to place one tunnel above the other.

In general contour the line may be viewed as consisting of three sections—Finsbury Park to Holborn, Holborn to Earl's Court, and Earl's Court to Hammersmith—the first and third falling to-

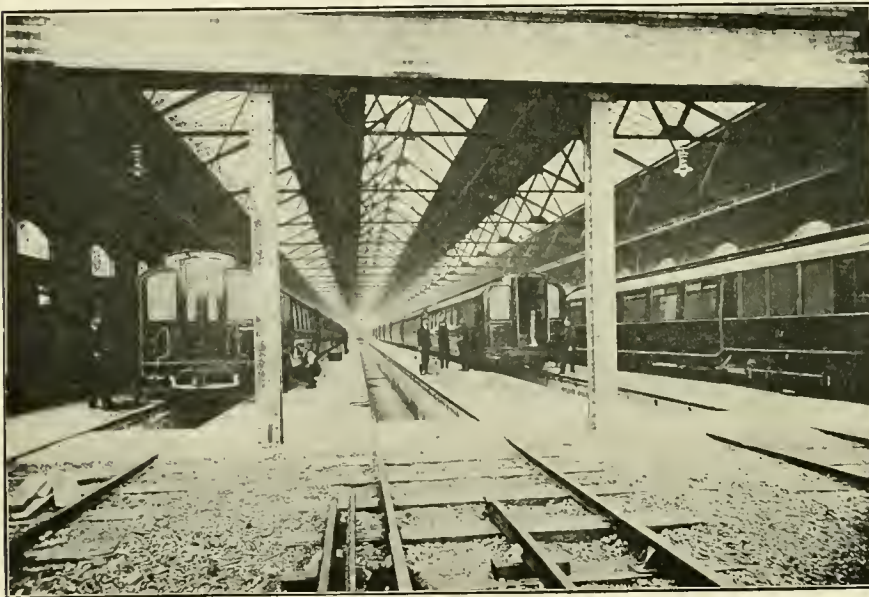

REPAIR SHOPS GREAT NORTHERN, PICCADILLY AND BROMPTON, AT LILLIE BRIDGE.

tor. In addition to the relations between speed, torque and horse power, characteristic curves usually include also the efficiency of the motor, that is, the ratio of the output to the input. Fig. 1 shows the characteristic curves of a 500 volt 40 H. P. railway motor in the form in which they are ordinarily plotted. These curves give a complete description of the performance of the motor. For instance, it may be seen that when developing its normal load of 40 H. P. the motor runs at a speed of 11½ M. P. H. and develops a tractive effort of 1,305 lbs., and that it requires a current of 72 amperes at 500 volts in order to develop this horse power, also that under these conditions the output in mechanical horse power is 83 per cent of the input in electrical horse power. The performance at any other output may be seen in the same way. Instead of plotting the curves in terms

The ability of the series motor to produce a large increase in tractive effort by slowing down in speed is similar to that of a steam locomotive. Fig. 3 shows the characteristic curves of a steam locomotive, and it will be seen that its tractive effort varies with the speed in a manner similar to that of the series motor. The motor has a great advantage over the locomotive, however, in that the horse power developed by the latter is greatest at the higher speeds, and although the tractive effort of the locomotive increases as the speed falls off, it does not increase as much as the speed decreases. Thus, in Fig. 3, at the normal speed of 18 miles per hour, the locomotive develops a tractive effort of 18,000 lbs. with a horse power output of 865. If the speed falls to one-half, or nine miles per hour, the tractive effort is 31,000 lbs., or less than double the former value, because the horse

wards the middle section, which is more or less level. As is usual with lines of this nature, the stations are approached on a rising or retarding gradient, 1.5 per cent, and left on a down or accelerating gradient, 3.0 per cent. The line of route followed has necessitated many curves, varying in radius from 1,320 to 330 ft.; a special feature in this direction is a

non-inflammable wood. One novel point about these lifts is that in every case passengers leave from the side opposite to that at which they enter, the exit gates being operated by the attendant at his post by the entrance gate with the aid of compressed air.

No less than nineteen exhaust fans, driven by 10-H. P. motors at 250 revolu-

scured by curves, "repeater" signals are provided in advance, the lights being yellow (instead of the "stop" red) for "on" and green, as usual, for "off." Another point of special interest is the fog signalling machines which, when required, automatically place detonators on the rails on the open section of the line. Every signal is provided with a train stopping device whereby the air cock on any train overrunning a danger signal is actuated and the brakes applied. By means of illuminated track diagrams in the signal cabins, the position of every train in the neighborhood can be seen at a glance. The telephone installation is of a most complete character, every station, signal box or other point of action being connected to Leicester Square, where a 100-pair switchboard is located. A novelty is a couple of bare wires along the side of each tunnel, which the motorman of a train can at any point in the tunnels tap with a portable instrument which he carries, and thus place himself in telephonic communication with adjoining stations.

The rolling stock consists of two special British built cars, and 72 motor and 144 "trailer" cars (half built in France and half in Hungary), admitting of the make-up of 36 trains of six coaches, arranged with a motor car at each end and four trailers between. The cars are built almost entirely of steel, what small quantity of wood is employed being rendered non-inflammable. They are each



MOTOR COACH USED IN THE PICCADILLY TUBE.

long reverse S curve near South Kensington.

The track is laid on the usual concrete bed, the sleepers of Australian Karri wood and rendered non-inflammable, and the running rails are of Bessemer steel of bullhead section, weighing 90 lbs. per yard, laid to the standard gauge, with an inward cant of 1 in 20. The conductor rails are of rectangular section weighing 85 lbs. per yard. The ballast is of  $\frac{3}{8}$ -in. granite cubes, and for two feet above the ballast level the iron segments of the tunnel are lined with concrete in order to secure the best possible insulation.

Three-phase alternating current for operating the Piccadilly and its associated lines is supplied at 11,000 volts from the great power station of the Underground Electric Railways Company at Lots Road. Three rotary converters of 800 k.w. each are provided at Hyde Park corner, and two of 1,200 k.w. each at Russell Square and Holloway Road, respectively. The current is fed to the conductor rails at from 550 to 600 volts.

The steel framework of the passenger station buildings is clothed with terra cotta glazed blocks, the doorways and windows being arranged in a series of arches. The roofs are flat, in order to provide for additional stories when found necessary.

The usual spiral staircases, from the booking offices above to the platforms below, are entirely of steel, while the lifts are also of improved pattern, with several new features in the way of safety devices. The cages of the lifts are each 150 sq. ft. in area, and carry 70 passengers; they are of steel, with floors of

tions per minute, with outcast through the roof of the surface buildings, are distributed over the length of the line. These, in conjunction with the air inlets provided by the numerous lift shafts, staircases and communicating passages, and the piston-like aid of the moving trains, circulate 21 million cu. ft. of air

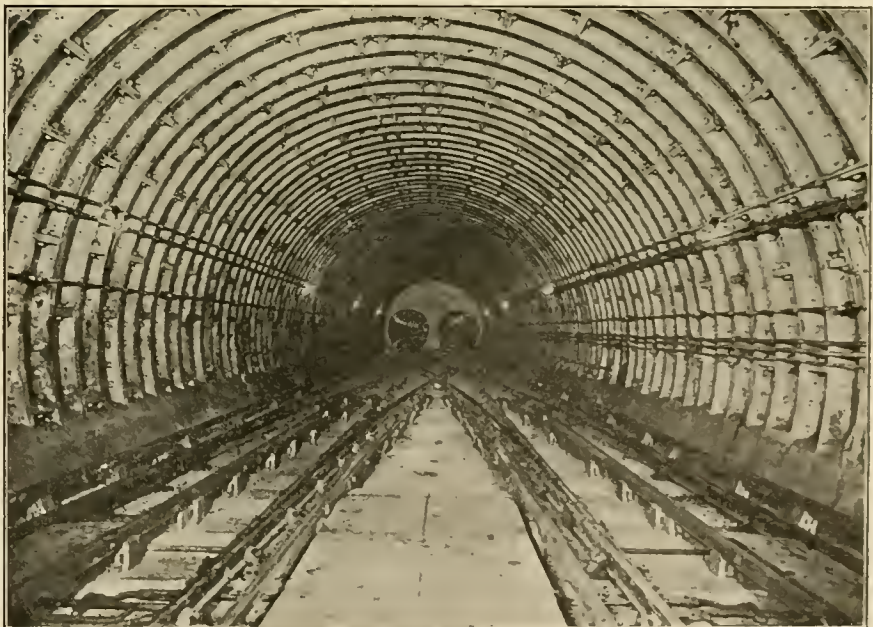

INTERIOR OF THE TUBE. CROSSOVER AT FINSBURY PARK.

per hour, and thereby ensure excellent ventilation.

The signalling is on the Westinghouse electro-pneumatic system, and is automatic wherever possible. Generally, there are no distant signals; but where the motorman's view of stop signals is ob-

scured by curves, "repeater" signals are provided in advance, the lights being yellow (instead of the "stop" red) for "on" and green, as usual, for "off." Another point of special interest is the fog signalling machines which, when required, automatically place detonators on the rails on the open section of the line. Every signal is provided with a train stopping device whereby the air cock on any train overrunning a danger signal is actuated and the brakes applied. By means of illuminated track diagrams in the signal cabins, the position of every train in the neighborhood can be seen at a glance. The telephone installation is of a most complete character, every station, signal box or other point of action being connected to Leicester Square, where a 100-pair switchboard is located. A novelty is a couple of bare wires along the side of each tunnel, which the motorman of a train can at any point in the tunnels tap with a portable instrument which he carries, and thus place himself in telephonic communication with adjoining stations.

The Sprague-Thomson-Houston multiple-unit control system of electrical equip-

ment has been adopted, with two 200-H. P. motors of the G. E. 69 type to each motor coach, the electrical apparatus being arranged on one side of the motor-man's cab and the compressed air reservoir for the Westinghouse brake on the other. The master controller is manually operated and non-automatic, being so arranged that if from any cause the motorman moves his hand from the operating handle power is at once shut off from the train and the brakes are applied. The interior of the cars is panelled in mahogany, mounted on uralite, and finished in choice manner. Thirty-five incandescent lamps effectively light each car. The usual cross and longitudinal scheme of seating has been adopted, 46 seats being provided in each motor car and 52 in each trailer.

There are no reduced-rate return tickets, but season tickets are issued and through booking arrangements are made with associated tubes and tramways and

I could go down to the storeroom and ask the storekeeper how many units of a certain material we used at a certain point and he didn't know. He didn't have any idea of how many units of a certain article were used at a particular point the previous month, and didn't know how many he had on hand. Of course, the storekeeper is always willing to order just what you want if you can give a reason why you want it. We ought to encourage the storekeeper and foreman to get together and try and approximate the amount of material used of one particular kind and try to keep a good stock of that on hand. This would obviate the necessity of keeping a useless supply of stuff, because it is capital tied up. Take, for instance, injectors. We have a great many different kinds. Every time we get a new class of engine, we have a different injector. If we want a piston for any

dependent on the mechanical department, and if the best feeling does not exist between them, then somebody is going to suffer. If we had a system that we could refer to at any time to give us an idea, I believe it would be a great help to the store department.

Mr. C. A. Swan, speaking on the same subject said: I was indirectly interested in formulating a plan to be used in a storehouse in connection with a big railroad. We got up a blue print book. Every article that was in that storehouse was numbered, no matter what it was. If a man telegraphed in from an outlying point and wanted a 9½ in. pump, he would not use the word "pump," but would say send No. 243 complete. The word "complete" would mean that you wanted the fittings that belonged to the pump. If you wanted a governor, you would not add the number of the governor, but right below you would put number so and so. If a machinist or inspector came to your shop and told you that a certain type of engine had broken down and he needed a certain part, the foreman never looked for the article by name, but looked for its number.

I knew this subject was coming up and I came down over one of our trunk lines and visited a foreman. We went over the roundhouse and in general conversation, I said to the storekeeper, "how much actual stock do you carry?" The only reply is the one I refer to. He says "I had thirty-six cylinder heads lying out here. An order came from headquarters to turn that stuff into scrap. We were carrying too much stock—too much money involved." How did that pan out? The storekeeper said, "it operated all right, only I had an engine waiting four days for a cylinder head." I said to the foreman after we walked away, "is that a fact?" He said, "yes, they have 8,000 mile trackage of main line. I telegraphed for it to their storehouse and I have got to wait now until they make a pattern, as they had destroyed the old one." Now, while we are hammering at the storehouse, the storehouse is being hammered at by the big fellow when he brings in his accounts at the end of the month. If you will give this plan I told you about a little consideration, I think you will find your first case your last one. Every storehouse should have these boxes or divisions, and when the stuff comes in, the storehouse keeper who checks this stuff is responsible that every article goes up in the right boxes. I think if the proper relations exist between the store department and the foreman, they do not have to carry a big amount of stock on hand.

Another thing, and that is to find out



ENGINE ON THE RAJAPUKANA MALWA RAILWAY, INDIA.

connecting or contiguous steam railways. The daily number of passengers approximates to 50,000.

#### The Stores Department.\*

Mr. W. H. Graves of the Hicks Locomotive Works, in the discussion of this subject at the recent meeting of the General Foremen's Association in Chicago, said, I think we ought to devise some method of keeping the storekeeper informed of what we actually need. We have all been up against the lack of material and power taken out of service because of it. The great trouble is, though, you are liable to have a surplus of a certain kind of stock. Now, I know from experience,

particular pump, we get just what we want by taking our book and ordering that number. If you were on the road and sent in for an injector for such and such an engine, he writes back and asks what kind of an injector and what is the number. If you write in and say you want a 9½ in. pump, or Westinghouse pump, for a certain class of engine; he knows the kind of a pump and he sends that out. Suppose you were to keep a stock of injectors on hand, probably the very kind you want you would not have in stock. Mr. Keller's paper has devised some method of getting us in harmony with these people so that they will know the different classes of material we use, and try to keep a good supply on hand. As a rule the storekeeper is entirely

\*Original paper on page 311 of this issue.

the amount of stock you have on hand. I know of a foreman right around here who had an injector hidden under the bench and the storekeeper didn't know anything about it. I know one foreman who had an air pump buried. He did that for this reason. The management came down over the line with expert accountants who went over the stock. They found that he had so much stock lying upon the shelves covered with cobwebs and dust that they would not issue any requisitions and were going to reduce that stock. While I was there, a pump was brought in for repair. He could not repair it within the time specified, so he took out this pump that he had buried and replaced it.

#### Consolidation for the Western Pacific.

The Baldwin Locomotive Works have recently completed 20 heavy con-

solidation engines for the Western Pacific Railway. The dome is placed on the third ring, which has a welded seam on the top centre line reinforced by an inside liner.

There is nothing unusual in the details of this locomotive, but the engine embodies features which have proved satisfactory in service. The tractive power is 47,120 pounds. The cylinders are 22x30 ins. and ordinary balanced D-slide valves are used.

Some of the principal dimensions are as follows:

Boiler—Type, straight; material, steel; diameter, 80 ins.; thickness of sheets, 13-16 in.; working pressure, 200 lbs.; fuel, soft coal; staying, radial.

Firebox—Material, steel; length, 121 ins.; width, 40 ins.; depth, front, 80½ ins.; back, 78½ ins.; thickness of sheets, sides, ¾ in.; back, ¾ in.; crown, ¾ in.; tube, ½ in.

Water Space—Front, sides, back, 4 ins. Tubes—Material, iron; wire gauge, No. 12; number, 390; diameter, 2 ins.; length, 14 ft. 5 ins.

Heating Surface—Firebox, 214 sq. ft.; tubes, 2927 sq. ft.; total, 3141 sq. ft.; grate area, 33.6 sq. ft.

who secured the right of way to Smithville had promised that in case the right of way was granted the road would build up the city until it would become a dangerous rival of St. Louis. But they failed to see that the other road had done anything to increase the demand for groceries or dry goods, and in their righteous indignation they were willing to turn over their patronage to a rival corporation.

When the heart of a community is stirred to the core with ambition or revenge something important is likely to happen. The Smithvillites arose in their might, assembled themselves in mass-meetings, and poured forth much high-pressure wrath against their enemies, directing the stream straight in the face of all corporations, but particularly against railroad corporations as represented by the Morning Sun Route. Committees were appointed to devise means of relief,

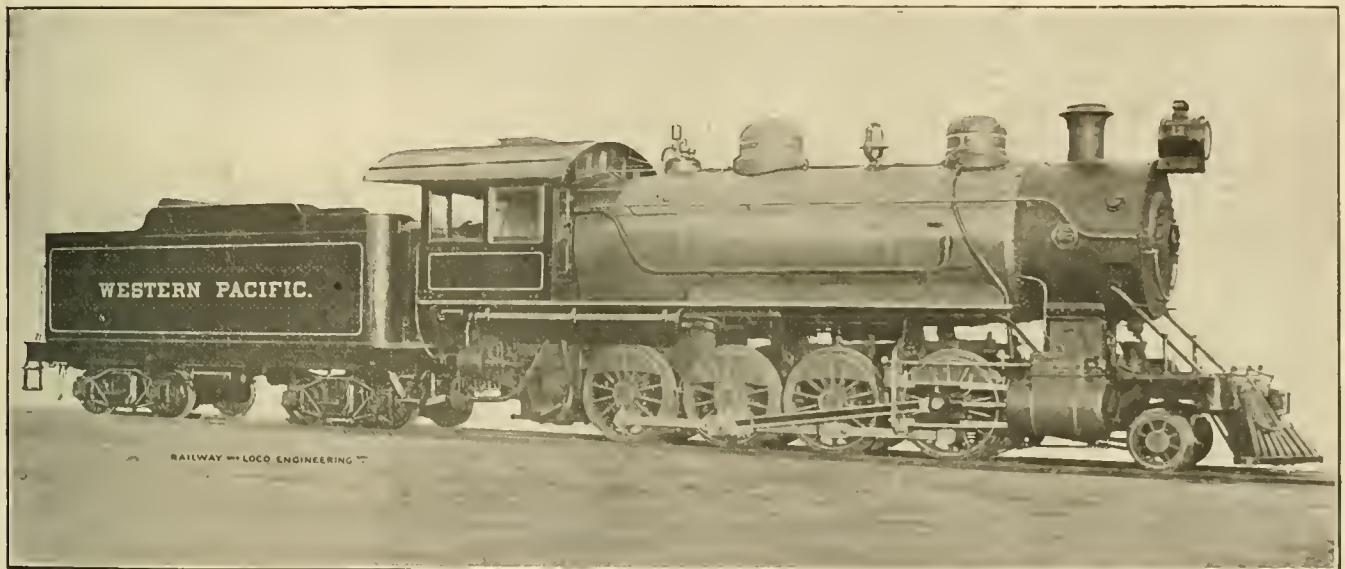

CONSOLIDATION ENGINE FOR THE WESTERN PACIFIC.

W. G. Bogue, Vice Prest. and Chf-Eng.

Baldwin Loco. Works, Builders.

solidation locomotives for the Western Pacific Railway. These engines are interesting, as they are among the first to be received by this road. They bear the numbers 1 to 20. These locomotives have single expansion cylinders 22x30 ins., with slide valves, which are actuated by the ordinary shifting link motion. The eccentrics are placed on the main driving axle, and the links are connected to the rocker shafts by transmission bars which span the second axle.

The boiler is fitted with a narrow firebox having the grate placed above the frames. The mud ring is 4 ins. wide all round. The curves in the side sheets have large radii, thus avoiding abrupt changes in the contour of the water legs. The firebox is radially stayed, with sloping crown and roof sheets and vertical throat and back

Driving Wheels—Diameter, outside, 57 ins.; journals, main, 10x12 ins.; others, 9x12 ins. Engine Truck Wheels—Diameter, 30 ins.; journals, 6x12 ins. Wheel Base—Driving, 15 ft. 8 ins.; total engine, 24 ft. 4 ins.; total engine and tender, 57 ft. 11½ ins. Weight—On driving wheels, 186,330 lbs.; on truck, 15,000 lbs.; total engine, 201,330 lbs.; total engine and tender, about 350,000 lbs. Tender—Wheels, diameter, 33 ins.; journals, 5½x10 ins.; tank capacity, 8000 U. S. gallons; coal capacity, 14 tons; service, freight.

#### Railroading Under Difficulties.

By SAM RARUS.

The city of Smithville, Missouri, was languishing because it had no natural resources for the building up of anything larger than an agricultural trading post, and the people believed that the depression in business was owing to the lack of railroad competition. The main line of the Great Morning Sun Route passed through Smithville, but the Smithvillites were not satisfied. The people remembered with bitterness and rage that the agents

and the whole influence of Smithville was pledged to support any schemes which, to quote the words of a resolution, "are calculated to mitigate the despotism or lighten the burdens under which the industries of the city are groaning."

How it came to pass I cannot tell, but one of these committees induced my uncle, the receiver of the St. Louis, Western and Moribund Railroad, to finish and put in operation a part of the great transcontinental railroad, of which the United States Court had appointed him custodian, lying between Smithville and the Evening Star Through Railroad. By going ten miles in the wrong direction the citizens of Smithville were thus enabled to obtain for themselves and their goods what was described as a new and direct route to eastern markets. The connection was duly built, and if laying down wornout iron on the poorest kind of a roadbed, without sur-

facing or gravel, may be called finishing, the road was finished. At this time I took part in the fortunes of the road.

Railroading always had great attractions for me, but till the opening of the Smithville extension fortune had confined me to the prosaic drudgery of retailing red herrings, molasses and other sundries at a grocery store in a small Missouri town. At my earnest solicitation my uncle appointed me general superintendent of the new railroad, which the Smithville people with ungrateful levity called "The Plug." My charge, the finished portion of the St. Louis, Western and Moribund Railroad, was ten miles long, and was operated by two trains run each way daily. We did not make ostentatious pretensions as railroad men. All the building we had was an old box car body, which was used as passenger depot at Smithville. For rolling stock we had a combined coach and baggage car that the Evening Star Route had found unsafe for their through trains, and an old locomotive which the boys in the neighborhood called the "Mud Turtle," owing to some supposed similarity in appearance or habits. There was no engine-house, no tools of any kind, no

ger of that kind existed, for the speed was always regulated to give the stupidest animal time to get out of the way. This method of operating was deliberately arranged, for it was well understood that the striking of a horse or the killing of a cow would entail paying for the animal, an expenditure that would seriously embarrass the receiver's financial resources. Yet, in spite of all precautions, an accident happened which not only put tremendous tension upon the financial resources of the road, but threatened for a time to indefinitely suspend operations through obstructing the track.

Near Smithville a high trestle was used as a means of crossing a high defile. The ends of the trestle were in a pasture where cattle and horses roamed heedless of the track. The engine and car had passed through this pasture daily for several months, and the animals had grown so much accustomed to the train that there sometimes was difficulty in getting them to keep away from the engine's cow-catcher. One day the side track at the junction, which we used for switching purposes, was so deeply sunk in the mud that we could not use it, and thought it

abusive, but I was master of the situation and meant to save that horse and lift him up, too, if I had to send to St. Louis for a derrick to do the work. The engineer, who had more experience of these things than I had, said if I could get a block and fall in Smithville, and a telegraph pole, he would get the horse out safely. I could see no better way, so I adopted the engineer's plan; but when I went to Smithville and searched for a block and fall I found there was no such thing in the city. After a long search I discovered that a man in a town about eight miles away, who did house moving, possessed the articles I required. There apparently being no better way out of the difficulty, I hired a horse and drove out to where the man lived. I found him and had no difficulty in bargaining for the use of the tackle, so I returned to Smithville in triumph. By this time it was dark and nothing could be done till morning. Bright and early I got out to the trestle in the morning and found things in *status quo*. The horse was still lying helpless, with his legs hanging between the ties, and the engine was waiting to get past.

We proceeded with the least possible delay to prepare for lifting the animal out and so clear the track. The block and fall was attached to a telegraph pole secured to the trestle. Before we began raising the animal up I thought it would be a good plan to get planks slipped under the horse so that he would get solid footing as soon as we got him up, so I directed my assistants to try and get the planks pushed into the proper position. They had got one in all right, and were working the other under, when the horse began struggling. Just how it happened I never could make out, but before we could do anything to secure him the horse was on his feet, and in another instant was tumbling over the side of the trestle. He went down twenty-six feet and broke two of his legs.

I had done the best that was possible to save the road from loss, but my efforts were not appreciated. My uncle, the receiver, happened to visit Smithville two days afterwards, and some of the passengers who were delayed gave their version of the affair before I met him. I am not general superintendent any longer—in fact, I am a freight brakeman on the Long & Short Haul Railway, where I exerted so much influence on the side of order during the strikes of last summer that I expect soon to be promoted.

The longest bridge in the world is at Sangong, China, and is called the Lion bridge. It extends five and a quarter miles over an arm of the Yellow Sea, and is supported by 300 huge stone arches. The roadway is seven feet above the water, and is enclosed in an iron network. It is a very remarkable structure.

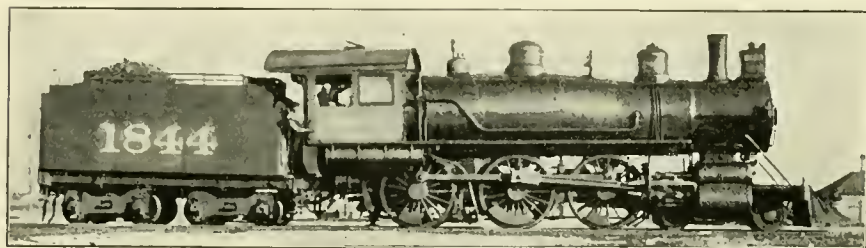

UNION PACIFIC VAUCLAIN COMPOUND TEN-WHEELER IN THE WEST.

water tank, no turn-table. In fact, there was nothing superfluous or useful beyond the track, the car and the bare locomotive. As there were no office duties to perform, and as the road could not support idle men, I made myself a good example by performing the duties of conductor and brakeman. In fact, there were only three trainmen—myself, the engineer and fireman. We were a happy family and helped each other along. When a farmer stopped the train anywhere to take on a load of potatoes, the engineer and fireman would come back and help to load the produce into the car, and when they stopped at a woodpile to get fuel to keep the locomotive going I would regularly help them with the wood. This familiarity all round was not without its inconveniences, for the farmers would stop the cars anywhere or at any time to ask how the price of hogs was, or whether it would be best to send their butter to Smithville or Rentsell, a city of twelve hundred inhabitants in the opposite direction.

Of course, the track was not fenced, and there was no need for anything of the kind to protect stock from the danger of being struck by the locomotive. No dan-

the safer plan to return to Smithville, pushing the car in front of the engine. We got along this way without any mishap till we reached the pasture referred to, when a sudden panic seemed to seize the animals as they caught sight of the unusual spectacle of the car being pushed in front of the engine. One young horse was so frightened that he ran on to the trestle, and after passing over about thirty feet on the ties fell down, with his legs dangling through. The train was stopped readily enough, but when we went on to the trestle and tried to get the horse out we found he was stuck fast. The passengers came out and helped with hands and suggestions—especially the latter—but lift the horse we could not, and I was afraid to have him pulled round much lest he might fall off the trestle and break his neck. The suggestion was made by the engineer that he borrow an axe somewhere and chop the ties so that the horse could fall through, but I knew the road could not bear any such expense. I told the passengers that the train was abandoned and that they might walk to Smithville, which was only three miles away. Some of them growled and others were

# Items of Personal Interest

The following officers were elected at the annual convention of the American Railway Master Mechanics' Association at Atlantic City: President, Mr. Wm. McIntosh, superintendent of motive power on the Central Railroad of New Jersey at Jersey City; First Vice-President, Mr. H. H. Vaughan, superintendent of motive power on the Canadian Pacific Railway at Montreal, Que.; Second Vice-President, Mr. G. W. Wildin, assistant superintendent of motive power on the Lehigh Valley at South Bethlehem, Pa.; Third Vice-President, Mr. F. H. Clark, general superintendent of motive power of the Chicago, Burlington & Quincy at Chicago, Ill.; Secretary, Mr. J. W. Taylor, 390 Old Colony Building, Chicago, Ill.; Treasurer, Mr. Angus Sinclair, editor RAILWAY AND LOCOMOTIVE ENGINEERING, New York.

Mr. James Simpson has been appointed master mechanic of the Fargo division of the Northern Pacific at Fargo, N. D.

Mr. W. B. Chapin, who has been chief engineer on the Tonopah & Goldfield Railroad at Tonopah, Nev., has resigned.

Mr. C. M. Tritsch has been appointed master mechanic of the Maryland division of the Western Maryland at Hagerstown, Md.

Mr. C. M. Harris has been appointed master mechanic of the Washington Terminal Company with office at Washington, D. C.

Mr. N. P. Anderson has been appointed roadmaster of the First District of the Missouri & North Arkansas at Seligman, Ark.

Mr. W. E. Bogart, chief engineer of the Wichita Valley Railway, has resigned to go to the Kansas City, Mexico & Orient Railway.

Mr. J. E. Mellen has been appointed roadmaster of the National of Mexico at Monterey, Mex., vice Mr. George Budge, resigned.

Mr. William Bennett has been appointed roadmaster of the Second District of the Missouri & North Arkansas, at East Harrison, Ark.

Mr. W. A. Christian has been appointed assistant engineer of the Chicago Great Western Railway with headquarters at St. Paul, Minn.

Mr. J. B. McIntosh has been appointed superintendent of heat, light and power of the Washington Terminal Company at Washington, D. C.

Mr. H. J. Tierney has been appointed to the new office of mechanical engineer of the Missouri, Kansas & Texas with office at Parsons, Kan.

Mr. C. W. Haines, formerly chief engineer of the Richmond, Fredericksburg & Potomac Railroad, has resigned and the office has been abolished.

Mr. G. O. Hammond has been appointed assistant to the mechanical superintendent on the Erie Railroad with headquarters at Meadville, Pa.

Mr. George Dow, for many years master car builder of the Lake Shore & Michigan Southern is now mechanical inspector on the same road.

Mr. W. H. Towner has been appointed acting general foreman on the Grand Trunk Railway at Toronto shops, vice Mr. J. C. Gerden, resigned.

Mr. James McDonough has been appointed superintendent of motive power on the Vera Cruz & Pacific Railroad with headquarters at Tierra Blanca.

Mr. M. A. Brophy has been appointed road foreman of engines on the Delaware, Lackawanna & Western Railroad with headquarters at Hoboken, N. J.

Mr. F. E. Secor has been appointed road foreman of engines of the Central New England Railway and its branches with office at Hartford, Conn.

Mr. J. F. Whiteford has been appointed general roundhouse inspector of the Atchison, Topeka & Santa Fe Railroad with office at Albuquerque, N. Mexico.

Mr. A. P. Glueck has been appointed district foreman of the Union Pacific in charge of motive power and rolling stock between Ellis and Junction City, Kan.

Mr. E. P. Lupfer, formerly division engineer of the northern division of the Buffalo & Susquehanna, has resigned to go into private business.

Mr. James Carr has been appointed master mechanic of the Midland Valley Railroad with headquarters at Muskogee, I. T., vice Mr. C. H. Welch, resigned.

Mr. W. R. Edwards has been appointed chief bridge draughtsman of the Baltimore & Ohio with office at Baltimore, Md., vice Mr. W. S. Bouton, promoted.

Mr. C. F. Brigham has been appointed assistant road foreman of engines of the Chautauqua division of the Pennsylvania Railroad, with headquarters at Oil City, Pa.

Mr. J. R. Scott has been appointed road foreman of equipment of the Western Division of the St. Louis & San Francisco Railroad with headquarters at Enid, Okla.

The following officers were elected at the annual convention of the Master Car Builders' Association at Atlantic City: President, Mr. Geo. N. Dow, general mechanical inspector on the Lake Shore & Michigan Southern Railway at Collinwood, Ill.; First Vice-President, Mr. R. F. McKenna, master car builder on the Delaware, Lackawanna & Western Railroad at Scranton, Pa.; Second Vice-President, Mr. R. W. Burnett, assistant master car builder on the Canadian Pacific Railway at Montreal, Que.; Third Vice-President, Mr. T. M. Ramsdell, master car builder on the Chesapeake & Ohio Railroad at Richmond, Va.; Secretary, Mr. J. W. Taylor, 390 Old Colony Building, Chicago, Ill.; Treasurer, Mr. John Kirby, on the Lake Shore & Michigan Southern at Adrian, Mich.

Mr. E. G. Chenoweth has been appointed mechanical engineer on the Erie Railroad with headquarters at Meadville, Pa., vice Mr. G. O. Hammond, promoted.

Mr. A. J. Alexander has been appointed superintendent of the Eastern Division of the Missouri Pacific Railway with office at Sedalia, Mo., vice Mr. H. G. Clark, promoted.

Mr. O. E. Maer has been appointed superintendent in charge of transportation, maintenance of way and motive power of the Wichita Valley, vice Mr. M. C. Jones, resigned.

Mr. Charles D. Barrett has been appointed assistant master mechanic of the Camden division of the Pennsylvania Railroad with headquarters at Jersey City, N. J.

Mr. R. J. Cottrell has been appointed acting locomotive foreman on the Grand Trunk Railway with headquarters at St. Thomas, Ont., vice Mr. H. W. Towner, transferred.

Mr. J. W. Dean has been appointed superintendent of the Missouri Division of the Missouri Pacific Railway with office at De Soto, Mo., vice Mr. J. Cannon, transferred.

Mr. J. M. Walsh has been appointed superintendent of the Central Division of the Missouri Pacific Railway with office at Van Buren, Ark., vice Mr. J. W. Dean, transferred.

The headquarters of Mr. S. Phipps, master mechanic of the Pacific Division of the Canadian Pacific Railway, have been changed from Revelstoke to Vancouver, B. C.

Mr. E. C. Burgess, formerly acting chief engineer, has been appointed chief engineer of the St. Louis, Brownsville &

Mexico Railway with office at Corpus Christi, Tex.

Mr. David Holtz, master of machinery of the Western Maryland, with office at Union Bridge, Md., has resigned after thirty years' service, and the office has been abolished.

Mr. J. C. Garden has been appointed acting master mechanic on the Grand Trunk Railway with headquarters at Fort Gratiot, Mich., owing to the illness of Mr. J. T. McGrath.

Mr. R. J. Turnbull, formerly master mechanic on the Illinois Central at Paducah, Ky., has been transferred as master mechanic to Memphis, Tenn., on the same road.

Mr. J. Cannon has been appointed superintendent of the Arkansas Division of the Missouri Pacific Railway with office at Little Rock, Ark., vice Mr. A. J. Alexander, transferred.

Mr. M. C. Hamilton has been appointed engineer of maintenance of way of the New York, New Haven & Hartford with office at New Haven, Conn., vice Mr. W. J. Black, transferred.

Mr. R. W. Cattermole, formerly division engineer of the Wisconsin Central, has been appointed to the new office of engineer of maintenance of way on the same road.

Mr. William Schlafe, formerly general master mechanic of the Erie, has been appointed assistant mechanical superintendent on the same road with headquarters at Meadville, Pa.

Mr. F. M. Hill has resigned as assistant superintendent of buildings of the Michigan Central at Jackson, Mich., to become engineer for the Reinforced Concrete Pipe Company of Jackson.

Mr. J. H. Mills, formerly road foreman of locomotives on the Canadian Pacific Railway, has been appointed district master mechanic on the same road with headquarters at Montreal, Que.

Mr. J. P. Hopson has been appointed superintendent of the New York division of the New York, New Haven & Hartford Railroad, at Fairfield, Conn., vice Mr. A. R. Whaley, resigned.

Mr. Delmar C. Ross, formerly general foreman on the Michigan Central, has been appointed master car builder on the same road. He has been with the Michigan Central for twenty-two years.

Mr. J. H. Fulmer, formerly foreman of shops of the Illinois Central at Paducah, Ky., has been appointed master mechanic at that point on the same road, vice Mr. R. J. Turnbull, transferred.

Mr. W. J. Robider, formerly general foreman of the car department of the Central Railroad of Georgia, has been appointed master car builder, on the same road, with headquarters at Savannah, Ga.

Mr. C. V. Wood has resigned as superintendent of the Wabash Pittsburgh Ter-

minal, the West Side Belt and the Wheeling & Lake Erie, to accept a position with the New York, New Haven & Hartford.

Mr. E. E. Austin, formerly road foreman of locomotives on the Canadian Pacific Railway, has been appointed district master mechanic of the Pacific Division on the same road with office at Nelson, B. C.

Mr. A. W. Wheatley has resigned as assistant superintendent of motive power and machinery of the Union Pacific to become general inspector of the American Locomotive Company at Schenectady, N. Y.

Mr. C. L. McIlvaine has been appointed assistant engineer of motive power of the Buffalo & Allegheny Valley division of the Pennsylvania Railroad at Buffalo, N. Y., vice Mr. S. C. Thomson, transferred.

Mr. W. S. Bouton, formerly chief bridge draughtsman of the Baltimore & Ohio, has been appointed assistant engineer of bridges and buildings, with office at Baltimore, Md., vice Mr. Wm. Graham, resigned.

Mr. W. S. Blennerhassett has been appointed road foreman of equipment of the Red River Division of the St. Louis & San Francisco Railroad, with headquarters at Francis, I. T., vice Mr. J. R. Scott, transferred.

Mr. E. L. Pollock, formerly purchasing agent of the New York, New Haven & Hartford, has been appointed vice-president in charge of purchases and stores of the Rock Island Lines, with headquarters at Chicago, Ill.

Mr. A. C. Terrell, formerly division engineer of the Northern Pacific at Spokane, Wash., has, at his own request, been transferred to his former position of assistant engineer on the same road at Trout Creek, Wash.

Mr. George Budge, formerly road-master of the Matamoras Division of the National of Mexico, has been appointed superintendent of maintenance of way of the Tehuantepec National, with office at Rincon Antonio, Oaxaca.

Mr. W. Borbridge, formerly road foreman of locomotives on the Canadian Pacific Railway, has been appointed district master mechanic of Districts 3 and 4, Eastern Division, on the same road, with headquarters at Ottawa, Can.

Mr. W. E. Brooks, formerly inspector of passenger service, has been appointed superintendent of the Northern Kansas Division of the Missouri Pacific Railway with office at Atchison, Kan., in place of Mr. J. M. Walsh, transferred.

Mr. D. J. Carson, who has been with the American Brake Shoe & Foundry Company for the past two years, in charge of their New York office, has been appointed manager of the American Malleables Company of New York.

Mr. C. A. Siley, mechanical engineer of the Rock Island Railway, has been appointed president of the Western Railway Club for the ensuing year, and Mr. J. W. Taylor is retained as secretary, a position he has held for several years.

Mr. John Nicholson, formerly foreman of shops on the St. Louis, Brownsville & Mexico at Kingsville, Tex., has been appointed superintendent of motive power on the same road with office at the same place, vice Mr. H. H. Kendall, resigned.

As a special meeting of the directors of the Joseph Dixon Crucible Company, held May 31, to take action on the death of their vice-president and treasurer, the late John A. Walker; Mr. George T. Smith was elected vice-president, George E. Long, treasurer, and Harry Dailey was elected a director and secretary.

Mr. A. E. Mitchell, formerly expert and engineer of tests on the New York, New Haven & Hartford, has been appointed manager of purchases and supplies for this company and for the Central New England. He will perform his former duties as well as those of purchasing agent, heretofore performed by Mr. E. L. Pollock, resigned.

Mr. William D. Ennis has recently been appointed Professor of Mechanical Engineering in the Polytechnic Institute of Brooklyn, N. Y. Professor Ennis, who has for the past two years been engaged in special investigations in connection with power matters for the American Locomotive Company, served his time as an apprentice in the Rogers Locomotive Works at Paterson, N. J., before graduating from the Stevens Institute of Technology, where he was one of the first students to gain the American Railway Master Mechanics Association scholarship. As a practicing engineer, he has been most widely known through his technical writings. He was from 1901 to 1905 engineering adviser to various Rockefeller interests in the Northwest and elsewhere.

#### The Oldest Fireman.

When George Stephenson ran the "Rocket" on its first trip from Liverpool to Manchester, Mr. Edward Entwistle, a lad of fourteen years of age, acted as fireman. Mr. Entwistle is still living very comfortably in his own house in East Des Moines, Iowa. His reminiscences of railroading in Great Britain and America are very interesting, and but for an occasional attack of rheumatism Mr. Entwistle is hale and active. He has kept fully abreast of the times and is familiar with every detail of the modern locomotive. He is of opinion that the limit of size and speed in running of the twentieth century locomotive is being overreached.



**Franklin Air Compressors.**

The accompanying illustration shows one of the latest types of Franklin Air Compressors built by the Chicago Pneumatic Tool Company at Franklin, Pa. One of two such machines was recently installed in the power plant of the new South Altoona Foundry of the Pennsylvania Railroad. Each compressor has compound steam cylinders •12 and 21 ins., and two stage air cylinders 19 and 11 ins. diameter, all 24 in. stroke, designed for 100 lbs. terminal air pressure, with 125 lbs. steam at throttle, and having a piston displacement of 985 cu. ft. of free air per minute at 125 r. p. m. In the two stage compressor the frames have been designed in accordance with the most improved Corliss construction, the steam and air cylinders being tied tandem to each other with heavy tie-rods and rigidly supported by a sole plate.

Provision is made for a circulation of cold water the entire length of the cylinder, the water passing also through the heads, its cooling effect being especially concentrated around the discharge valves, which naturally receive the heat due to compression and friction that has not been eliminated by the water jacket during the process of compression. A novel feature is the outside water connection for conduct-

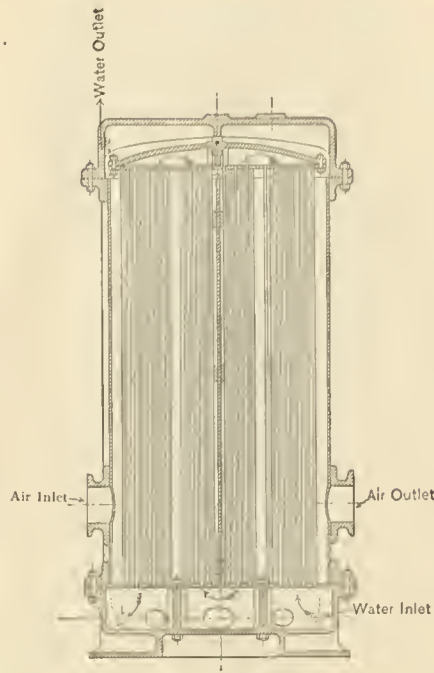

INTERCOOLER FOR ORIGINAL TWO-STAGE COMPRESSORS.

air intake valves, poppet and mechanically actuated. The poppet valves are placed in the cylinder heads from the outside and are immediately accessible for adjustment without removing the cylinder heads. They are made

may be independently removed, replaced and renewed. The valves and seats are held securely in place by large screw plugs over which caps are fitted. The proportion of valve area to cylinder area is such that it enables the cylinder to fill freely at each stroke.

The compressors of larger size are also built with mechanically moved intake valves of semi-rotary Corliss type, placed in the cylinder heads and driven by gear from eccentrics on the main shaft. These positively moved valves combine exceptionally liberal area with short ports and minimum clearance.

The motion to drive these Corliss Intake Valves is taken from the steam cut-off valve stem or rocker arm of the opposite side of compressor. The air discharge valves are of poppet type, cup shaped, pressed from high grade steel and fitted with light tension springs. These valves also have removable seats and guides and are readily accessible for adjustment or repair. The cranks are of the disc pattern, made from the best quality of charcoal iron. The shafts and crank pins are forced to their places, the former being keyed and the latter riveted. The intercooler, which is separate from the compressor, and may be placed where convenience dictates, is a most important feature. This consists of a

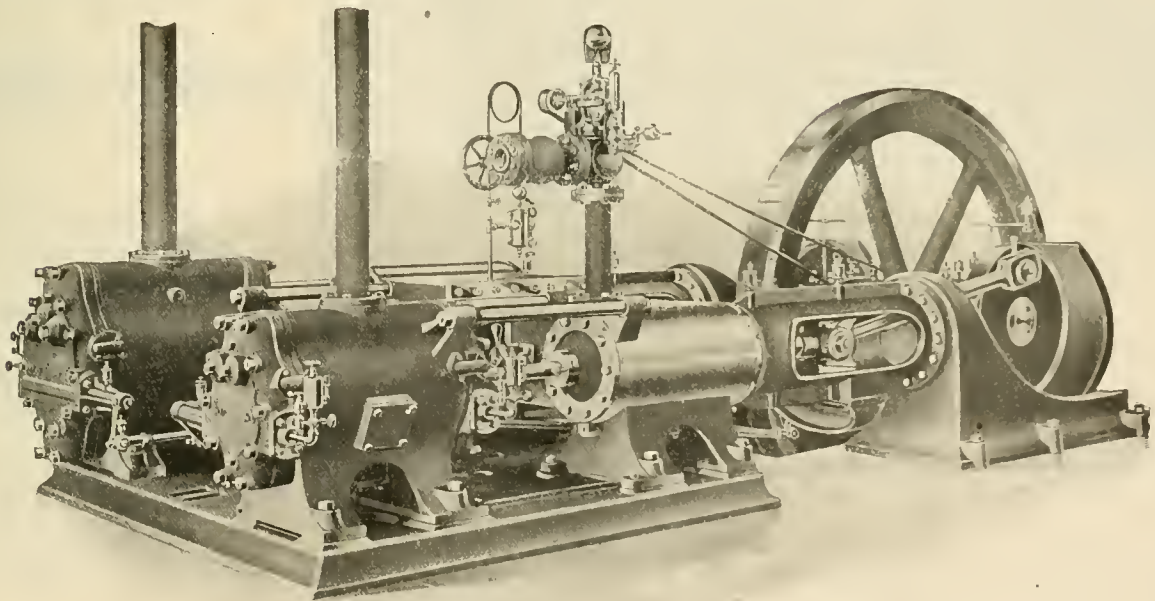

FRANKLIN AIR COMPRESSOR CLASS C. S. C.

ing water between the air cylinder and the cylinder head, thus excluding the possibility of accident by water entering the interior of cylinder should the gasket between cylinder and head become defective. These compressors are manufactured with two forms of

from high grade steel, having removable seats and guides easily renewed or repaired, and are thoroughly guarded from entering the cylinder. The valve stem and head are forged in one piece and the valve seat is a part entirely separate from the cylinder head and

steel shell containing a set of tubes, the tubes being fitted into the heads with provision for expansion and contraction. A constant circulation of cold water is maintained through the tubes and the compressed air from the initial compressing cylinder enters the

intercooler on one side, and after contact with the tubes, discharges from the other side, passing to the next compressing stage. Adequate provision is made for readily cleaning the interior of the intercooler, and the tubes being made of composition metal do not rust or become foul. The air passes in at opening marked "air inlet" and out at opposite side of shell marked "air outlet" in our illustration. A baffle plate is fixed in the center of the shell, extending from side to side and from the bottom tube sheet to within a few inches of the top tube sheet. Air entering from low-pressure cylinder is thus compelled to travel between closely spaced brass tubes up over the top of the baffle plate and down through an equal number of tubes to the outlet, on its way to the high-pressure cylinder. The combined base and water head is divided by cast iron partitions into three compartments, and the upper water head is divided into two compartments.

The cooling water enters at the bottom and is compelled to traverse the entire length of tubes four times before passing out. A handhole in each compartment of lower water head affords easy access for cleaning and by removing upper heads the tubes are accessible for same purpose. A drain is furnished for each water compartment. A drain is also provided for drawing out water from the air chamber. The air governor has a connection to the air receiver and regulates the steam supply to the compressor to suit the air consumption, thus maintaining a constant air pressure, even though the demand be intermittent. Working in combination with this governor is a speed governor for regulating the speed of the engine. Every compressor undergoes, before shipment, a thorough working test. All steam and air cylinders have indicator connections, and indicator diagrams are taken under exact working conditions. These cards must equal the established standard of efficiency. And finally, a test determines the capacity of the compressor in actual volume of compressed air delivered.

The Chicago Pneumatic Tool Company manufactures these Franklin Air Compressors in more than one hundred sizes and styles ranging in capacity from 30 to 5,000 cubic ft. of free air per minute displacement and suitable for a wide range of service in addition to the operation of pneumatic shop appliances.

Further information may be obtained from the Chicago Pneumatic Tool Company at their offices in Chicago or New York or from any of their branch offices in large cities.

#### Trouble in the Rogers Works.

There is rather serious labor troubles in the Rogers Locomotive Works at Paterson, N. J. The blacksmiths struck because a new general foreman who was put over them made rules which they held to be obnoxious. The men demanded the foreman's removal and the company refused. The men struck and nothing has been doing in the whole works since, for the closing of one department means the closing of all. The company insists upon hiring such foremen as they choose, and that the employees must work under them or not at all. As the Paterson shops are but one of the American Locomotive Company's numerous plants, there will be no difficulty in closing them up and sending all orders elsewhere. This would be an industrial disaster to Paterson. The Rogers shops have been established many years and were formerly among the largest industries in the State. It is to be hoped that the strike will be settled upon the principle of a "square deal" to both sides, and the re-opening of the plant. The Rogers Locomotive Works are the second oldest in the United States, having turned out their first locomotive in 1837.

The Railway Steel Spring Company of New York has recently issued an excellent catalogue of railway engine truck and coach steel tired wheels which are manufactured by them. They give among the half tones with which the pamphlet is illustrated a side view and section of the Paige Spoke wheel, the Paige Plate wheel, the Allen coach wheel and Allan engine truck wheel; also the National and the Boies wheels. The Fused spoke wheel is also illustrated, for engine truck, tender and coach service. Write direct to the company for a copy of the catalogue if you are interested.

#### Description Misunderstood.

Sir Robert Ball was at one time Astronomer Royal for Ireland, and is now the Lowndean professor of Astronomy and Geometry in King's College, Cambridge, and director of the Observatory. He is a native of the Emerald Isle and enjoys telling of the bewilderment of a "car" driver who was sent to meet him. Anyone who has seen the kindly face of the astronomer would be able to fully appreciate the incident.

Sir Robert was engaged to lecture on his own subject in a remote part of Ireland, but on his arrival at the little station he walked up and down the platform looking vainly for the expected conveyance. Finally, when all the other passengers had dispersed and driven off, a typical Irish servant came up to him and said: "Maybe you're Sir

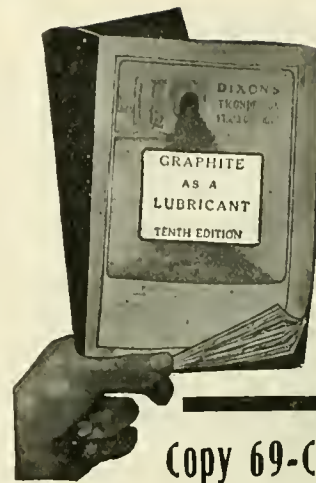

Copy 69-C FREE

Here is a complete and interesting story of graphite and its development as a lubricant. You can not get in any other book of equal size so much information of REAL value. The experience of practical men and the experiments of scientific authorities are both given in this TENTH EDITION of

## "Graphite as a Lubricant"

making it valuable to men of practice and students of theory.

Lubrication in almost every kind of machinery is treated of. "Kinks" and "short-cut" methods discovered and used by resourceful engineers are included.

You should get this book now. Write for FREE copy 69-C.

JOSEPH DIXON  
CRUCIBLE CO.  
Jersey City, N. J.

# GOLD Car Heating and Lighting Co.

Manufacturers of

ELECTRIC,  
STEAM AND  
HOT WATER  
APPARATUS  
FOR RAILWAY CARS

EDISON  
STORAGE  
BATTERY  
FOR RAILWAY CAR  
LIGHTING

Largest Manufacturers in the World  
of Car Heating Apparatus

Catalogues and Circulars  
cheerfully furnished

Main Office, Whitehall Building  
17 BATTERY PLACE  
NEW YORK

Robert Ball?" On receiving an affirmative reply, the man broke out, apologetically, "Oh, sure, your honor, I am sorry to have kept you waiting so long, but I was told to look out for an intellectual-looking gentleman!"

The H. W. Johns-Manville Company, of New York, have issued two little folders setting forth the merits of their Keystone range boiler covering which is a hair insulator consisting of thoroughly cleansed cattle hair, placed between two layers of strong, non-porous building papers, which may be either water or fire-proof, as desired, and securely stitched together every seven inches in the width of the bale. The hair, before it is enclosed in the papers, is chemically treated, leaving a coating of lime, which makes the finished material vermin-proof and odorless.

Another little folder issued by the same company deals with the "J.-M." asbestos roofing. One of the features of this roof-

### New 0-8-0 Mineral Locomotive.

This engine is to some extent a rebuild of the famous "Decapod" tank engine on the Great Eastern Railway of England, which was withdrawn from service for reasons connected with the permanent way department after vindicating its ability and power as a traffic-hauler. The engine has, as can be seen, eight coupled wheels occupying a long wheel-base which is rendered flexible to a certain extent by making the leading and trailing axleboxes of the radial type. There are two cylinders placed outside the frames, actuated by the ordinary shifting link motion; the connecting rods are 8 ft. 2 $\frac{3}{8}$  ins. long between centres, and the eccentrics have a throw of 5 $\frac{3}{4}$  ins. The boiler is of large dimensions with a barrel 12 ft. 11 $\frac{3}{4}$  ins. long and of 4 ft. 9 ins. maximum diameter, measured outside the first ring. The fire box is of the Belpaire type, 8 ft. long by 3 ft. 9 $\frac{3}{4}$  ins. wide. The frames are of the plate type 34 ft. 4 ins. long and 1 $\frac{1}{8}$  ins. thick,



MINERAL 0-8-0 ON THE GREAT EASTERN OF ENGLAND.

ing is that there is no wool or felt in its composition. It is made of long fibered asbestos, which is a mineral fibre and is fire-proof and acid-proof and does not rot or wear. Write to the Johns-Manville Company at 100 William street, New York, if you wish to get one or all of these folders or any further information on the subjects of which they treat.

The National-Acme Manufacturing Company of Cleveland, Ohio, are increasing the size of their factory by adding a new wing 400 ft. in length by six stories in height. Their special milled work made from brass and steel three-quarter inch and less in diameter, embraces every form of the smaller screwed attachments used in modern machinery. In the manufacture of the smaller class of screw machine products they have won an enviable reputation for high class work, while their rapidly increasing facilities enable them to guarantee prompt delivery, which is an important factor in the mechanical products of our time.

and are placed 3 ft. 10 $\frac{3}{4}$  ins. apart. The engine weighs 50 long tons 4 cwt 1 qr. empty, and 54 long tons 6 cwt. 3 qrs. in working order, and the tender weighs 17 long tons 11 cwt. 3 qrs. empty and 28 long tons 5 cwt. full.

A Scotsman went to London for a holiday. Walking along one of the streets he noticed a bald-headed chemist standing at his shop door, and inquired if he had any hair restorer. "Yes, sir," said the chemist; "step inside, please. There's an article I can recommend. I've testimonials from great men who have used it. It makes the hair grow in twenty-four hours." "Aweel," said the Scot, "ye can gie the top o' yer heed a rub wi' it, and I'll look back the morn and see if ye're telling the truth." The chemist returned the bottle to the shelf with disgust, and kicked the errand boy for laughing.

It is not alone what we do, but also what we do not do, for which we are accountable.—Moliere.

### Holmes Packing.

What is known to the trade as the Holmes metallic packing is made in sizes suitable for piston rods or valve rods. It is used on locomotives and also on stationary and marine engines. Like other forms of metallic packing it is intended to reduce the friction on the moving rod and yet maintain a steam-tight fit.

The packing is contained in a metal case, made in halves, and this case is made to fit any size of stuffing box, just as the packing is made to fit any rod. The case is securely screwed together and is pushed into the stuffing box. A joint of lead is made at the bottom of the stuffing box, or between the gland and the case.

On locomotives where cinders, sand and dirt are a constant source of trouble and wear to the rod, stem and packing, and causes the packing to be renewed very often, this form of packing is advantageous and a swab pocket is provided to catch the cinders, sand etc. Some results on the Philadelphia & Reading Railway with consolidation type engines, working

than in the knowledge and mastery of the mechanical appliances used on railways. Experience is absolutely necessary. Good reading is extremely desirable.

Right here, RAILWAY AND LOCOMOTIVE ENGINEERING supplies the necessary material. Its pages are filled with the expressions of the best thoughts of the leading railroad men of our time. It has met the universal approval of the leading railway men throughout the world. The price, \$2.00 a year, places it within the reach of every railroad employee.

"Twentieth Century Locomotives," Angus Sinclair Co., deals comprehensively with the design, construction, repairing and operating of locomotives and railway machinery. First principles are explained. Steam and motive power is dealt with; workshop operations described, valve motion, care and management of locomotive boilers, operating locomotives, road repairs to engines, blows, pounds in simple and

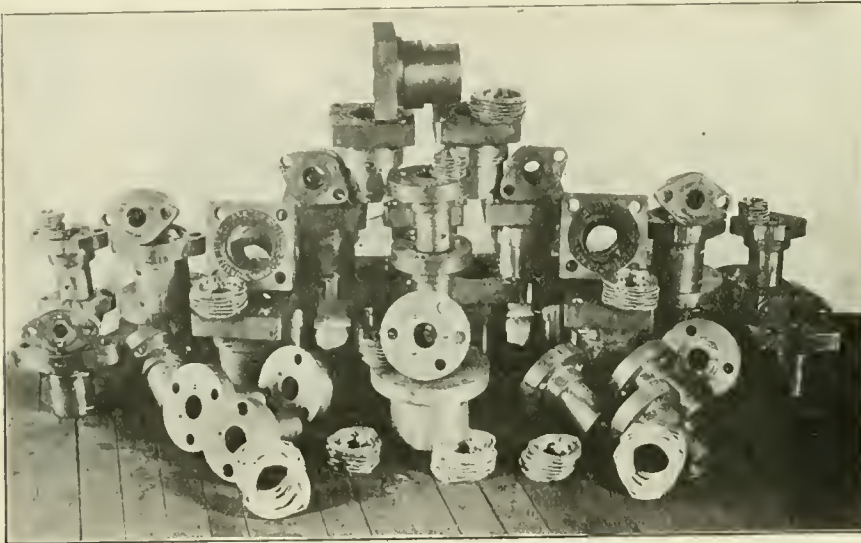

VARIOUS SIZES OF THE HOLMES PACKING.

24 hours a day, 7 days a week, have been published by this company and can be had on application. The packing is supplied on thirty days' trial. Write to the Holmes Metallic Packing Company, of Wilkes-Barre, Pa., for further information on the subject.

### Science.

Professor Huxley stated that "all accurate knowledge is science." An erroneous idea exists that science, like the Eleusian mysteries, is to be gained after long years of patient listening to exhaustive lectures. This is a gross error. Science in the best sense is learned by practical experience. Books are a necessary adjunct. Periodicals keep one abreast of the times. Nowhere in the realms of human endeavor are these essentials more necessary

compound engines; how to calculate power, train resistance, resistances on grades, etc. Shop tools explained. Shop recipes, definitions of technical terms, tables, etc. Descriptions and dimensions of the various types of standard locomotives. The book is well and clearly illustrated and is thoroughly up to date in all particulars, fully indexed. Price, \$3.00.

"Locomotive Link Motion," Halsey. Any person who gives a little study to this book ceases to find link motion a puzzle. Explains about valves and valve motion in plain language. Price, \$1.00.

"Locomotive Engine Running and Management," by Angus Sinclair, is an old and universal favorite. A well-known general manager remarked in a meeting of railroad men "I attribute

## JUST PUBLISHED The Walschaert Locomotive Valve Gear

By W. W. WOOD.

Nearly 200 pages.

Fully Illustrated.

PRICE \$1.50

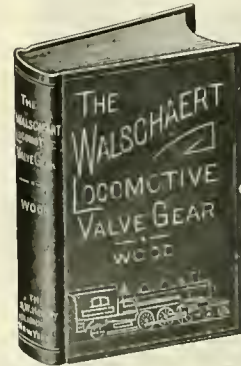

The only book issued that is devoted exclusively to the Walschaert Valve Gear, and it fills a demand which, during the last few months, has become very important. If you would thoroughly understand the Walschaert Valve Gear you should possess a copy of this book, as the author takes the plainest form of a steam engine—a stationary engine in the rough, that will only turn its crank in one direction—and from it builds up—with the reader's help—a modern locomotive equipped with the Walschaert Valve Gear, complete.

The points discussed are clearly illustrated; two large folding plates that show the position of the valves of both inside or outside admission type, as well as the links and other parts of the gear when the crank is at nine different points in its revolution, are especially valuable in making the movement clear. These employ aliding cardboard models which are contained in a pocket in the cover.

The book is divided into four general divisions, as follows: I. Analysis of the gear. II. Designing and erecting the gear. III. Advantages of this gear. IV. Questions and answers relating to the Walschaert Valve Gear, which will be especially valuable to firemen and engineers preparing for an examination for promotion.

Just Issued—1907 Revised and Enlarged Edition.

UP-TO-DATE

## AIR BRAKE CATECHISM

By ROBERT H. BLACKALL.

PRICE \$2.00

The Standard Book on the Air Brake. Contains over 2,000 Questions and Answers giving a detailed description of all the Old Standard and Improved Equipment.

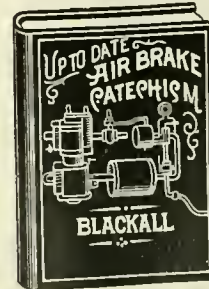

Owing to the many changes and improvements made in the Westinghouse Air Brake it has been found necessary to issue the new, revised 1907 edition of the Air Brake Catechism, which contains all the latest information necessary for a railroad man to pass his examination on the new as well as the older style of brake.

The new revised 1907 edition is right up to date and covers fully and in detail the Schedule E. T. Locomotive Brake Equipment, H-5 Brake Valve, SF Brake Valve (Independent), SF Governor Distributing Valve, B-4 Feed Valve, B-3 Reducing Valve, Safety Valve, K Triple Valve (Quick-Service) Compound Pump.

Send for a special circular of these books as well as our Other Railroad Books. Copies of these books sent prepaid on receipt of price.

Agents Wanted Write for our special terms. You can make equal to a month's pay selling our books on the side.

The Norman W. Henley Publishing Co.  
132 Nassau St., New York, U. S. A.



**RUBEROID ROOFING**

FOR  
**CARS SHOPS**  
**CABS ROUND HOUSES**

Contains no tar. Will not melt, rot, crack or corrode.

Not affected by extremes of temperature. Highly fire resisting.

Spark-Proof Cinder-Proof  
 Gas-Proof Weather-Proof

Write for samples and prices.

**THE STANDARD PAINT CO**  
 100 William St., New York.

Boston, Chicago, St. Louis, Kansas City, Philadelphia, Atlanta.

much of my success in life to the inspiration of that book. It was my pocket companion for years." Price, \$2.00.

"Practical Shop Talks," Colvin. This is a very helpful book, combining instruction with amusement. It is a particularly useful book to the young mechanic. It has a stimulating effect in inducing him to study his business. We sell it for 50 cents.

Spangenberg's Steam and Electrical Engineering has 672 pages, 648 illustrations. It may be called a complete library in one volume, and is in question and answer form; which is an easy way of obtaining useful information. Covers a wide field. Fully indexed for reference so that any subject may be readily turned to and answer found. Price, cloth, \$3.50.

The 1907 Air Brake Catechism, by C. B. Conger. Convenient size, 230 pages, well illustrated. New edition. Up-to-date information concerning the whole air brake problem, including the ET equipment in question and answer form. Instructs on the operation of the Westinghouse and the New York

catalogue of apparatus of the Wirt type, the current Wirt catalogue should be used. Copies may be obtained from the Wirt Electric Company of Philadelphia, or from the Cutler-Hammer Manufacturing Company of Milwaukee, or on application to any of the district offices of these concerns. The purchase of the



TRANS-CAUCASIAN OIL BURNING SWITCHER.

Wirt Electric Company will enable the Cutler Company to meet more fully than ever the requirements of their trade. Particular attention is called to the very complete line of battery charging rheostats developed by the Wirt Company, and to the Wirt field rheostats, which in 1902 were awarded the John Scott medal on

**Ball's Official R.R. Standard Watches**

16 AND 18 SIZE

17 and 21 Ruby Jewels, Sapphire, Pallets

Ball's Improved Safety Double Roller



As without question the finest watches that American talent and skilled labor can produce, and they are giving such universal satisfaction that we have no hesitancy in claiming that they are the best and safest railroad watch on the market. Tests severe and numerous have proven this fact to the most critical

users in all sections of the country, to which thousands of good Railroad and Brotherhood men are ready to certify.

We have an authorized agent in nearly every railroad center. Call on him for information and facts. Write us for descriptive matter.

**The Webb C. Ball Watch Co.**  
 Watch Manufacturers  
 Ball Building, Cleveland, Ohio, U. S. A.



BALTIMORE & OHIO 2-8-0 ENGINE OF MODERN DESIGN.

Air Brakes, and has a list of examination questions for enginemen and trainmen. Bound only in cloth. Price, \$1.00.

**Cutler-Hammer.**

We are informed that the Cutler-Hammer Manufacturing Company of Milwaukee, Wis., have recently purchased the business of the Writ Electric Company.



ON THE RAILS AGAIN.

The Cutler-Hammer Company are themselves makers of electric motor-controlling devices, and they will now take up the manufacture of Writ apparatus. Pending the incorporation in the Cutler-Hammer

recommendation of the Franklin Institute of Pennsylvania. Bulletins covering these and other lines of Wirt apparatus will be furnished on application.

**Valuable Engineer's Book.**

One of the most practical mechanical engineers of America was F. F. Hemenway, well known by his book on Indicator Practice. Hemenway wrote a book called "Catechism of the Steam Plant," which gives in small space a great mass of valuable information concerning the management of boilers and steam engines. The contents of this book ought to be familiar to every man in charge of engines and boilers. It costs only 50 cents and is for sale in the office of RAILWAY AND LOCOMOTIVE ENGINEERING, 136 Liberty Street, New York.

**Feed Water Softening.**

Incrustation and corrosion in steam boilers, due to the action of substances held in solution in the water, are subjects that have received more attention, probably, for many years, than any of the various ills with which steam boilers are afflicted, and the best method by which

**Patents.**

GEO. P. WHITTLESEY

MCGILL BUILDING WASHINGTON, D. C.  
 Terms Reasonable Pamphlet Sent

to overcome these complaints has been a much argued question.

Probably every engineer who is obliged to use hard water for making steam has, at one time or another, used one or more of the thousand and one schemes for mitigating the serious results that come from the continual use of such water. The principal methods in use are: Precipitation and neutralization, in the boiler itself, of the undesirable constituents in the water, through the medium of boiler compounds, and by the removal

Zephon Chemical Company of Chicago, who are making a line of compounds to suit the water that is to be treated, taking the actual constituents of the water in question, as shown by accurate chemical analysis. Their compounds are in granular or powdered form. The makers state that they contain nothing that will be injurious to boiler plates, valves or fittings; they will not induce foaming, will prove effective in cases of leaky flues, and will prevent oxidation and corrosion of the iron. Old scale, it is said,

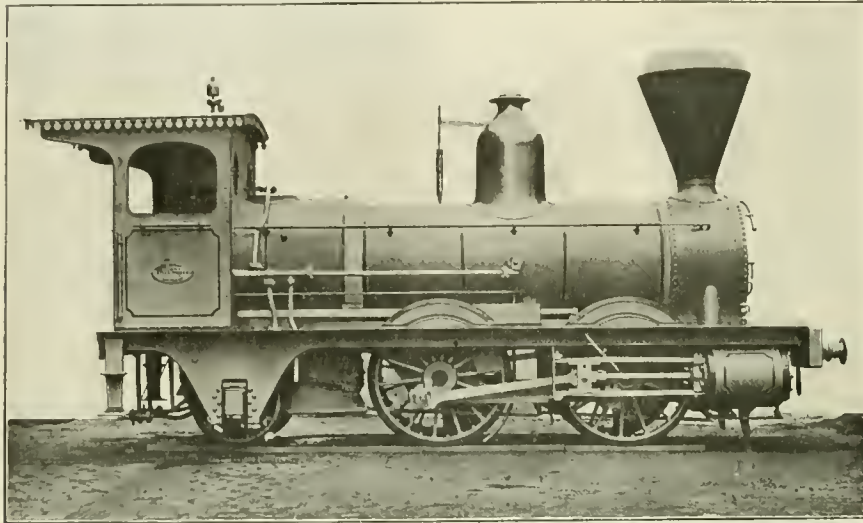

ONE OF THE SHARP, STEWART & CO. ENGINES OF LONG AGO.

of the objectionable constituents from the water before the latter is delivered to the boilers.

The records of the United States Patent Office contain many formulas for boiler compounds, etc., and in the last few years there have sprung into prominence several companies that have taken up this important question from a strictly scientific standpoint. They have established research laboratories and have expended large sums of money in experimental work, with the ultimate idea of eliminating the injurious constituents in the water and at the same time not to introduce anything that will cause injury to the boiler or its fittings.

Boiler compounds that are made on a basis of the actual analysis of the water, by a reputable concern, and sold at a reasonable price, have many arguments in favor of their adoption by steam users. They are easily applied, they are for the most part cleanly to handle, and there is no intricate machinery to be looked after during the process of softening, or anything to get out of order and thereby temporarily suspend the use of the apparatus while repairs are being made. The results obtained when a suitable compound is used are claimed to be very satisfactory, because the chemical reactions take place at a high temperature instead of in the cold.

Among the companies which do this kind of work may be mentioned the

will be rapidly removed and further deposition of scale prevented.

Prospective customers will be given an accurate technical analysis of boiler-feed waters free of cost and practical demonstration of the action of the compound will be given by this company. Inquiries from those interested addressed to their office in the Great Northern Building, Chicago, will receive attention. Trial samples will be furnished, and a demonstrator will call, if desired, to explain the application of the compounds and impart other information.

**Improvements on the Vandalia.**

In order to meet the increase of traffic over the Vandalia Railroad, a second track is being constructed from Knightsville, Ind., to East Yard at Terre Haute, Ind., a distance of about fourteen miles, and the grades along the line are being reduced. A new double track line is being built from Brazil, Ind., to Seelyville, Ind., north of the present route. The line now in use will be maintained as a third track when the new line is completed. The new double track line between these points will be about eight miles long. In the old line there are nine curves, aggregating 2.77 miles in length, and 208 degrees. On the new line there will be three curves, aggregating 0.66 miles in length, and a total angle of only 29 degrees. As a result, the

# Here's The Opportunity

## Are You the Man?

If an employer should say to you, "I want a man for an important position," would you be the right man? Opportunities like this are coming constantly to men trained by the INTERNATIONAL CORRESPONDENCE SCHOOLS, an institution that qualifies men to take advantage of every opening; to command high salaries; to succeed in the best positions.

Employers are daily applying to the Students' Aid Department of the I. C. S. for men to fill positions of responsibility, and during May of this year 447 students voluntarily reported advancement in positions and salaries, and this was but a small part of the whole number advanced.

Why don't YOU get in line for a good position? No matter who you are, what you do, or how little you earn, the I. C. S. can help you in your own home, in your spare time, for a better position and earnings. The first step is to mail this coupon. It costs nothing to do this and will bring you information and help that may eventually be worth thousands of dollars. **MAIL IT NOW.**

**International Correspondence Schools**  
BOX 805, SCRANTON, PA.

Please explain, without further obligation on my part, how I can qualify for a larger salary and advancement to the position before which is marked X.

General Foreman R. R.	R. R. Con. Engineer
R. R. Shop Foreman	Civil Engineer
R. R. Trav. Engineer	Bridge Engineer
R. R. Trav. Fireman	Chemist
Locomotive Engineer	Mining Engineer
Air-Brake Instructor	Architect
Air-Brake Inspector	Bookkeeper
Air-Brake Repairman	Stenographer
Mechanical Engineer	Ad. Writer
Mechanical Draftsman	French } With
Machine Designer	German } Edison
Electrical Engineer	Spanish } Phonograph

Name \_\_\_\_\_  
 St. & No. \_\_\_\_\_  
 Employed by \_\_\_\_\_ R. R.  
 City \_\_\_\_\_ State \_\_\_\_\_

# Tate Flexible Staybolt

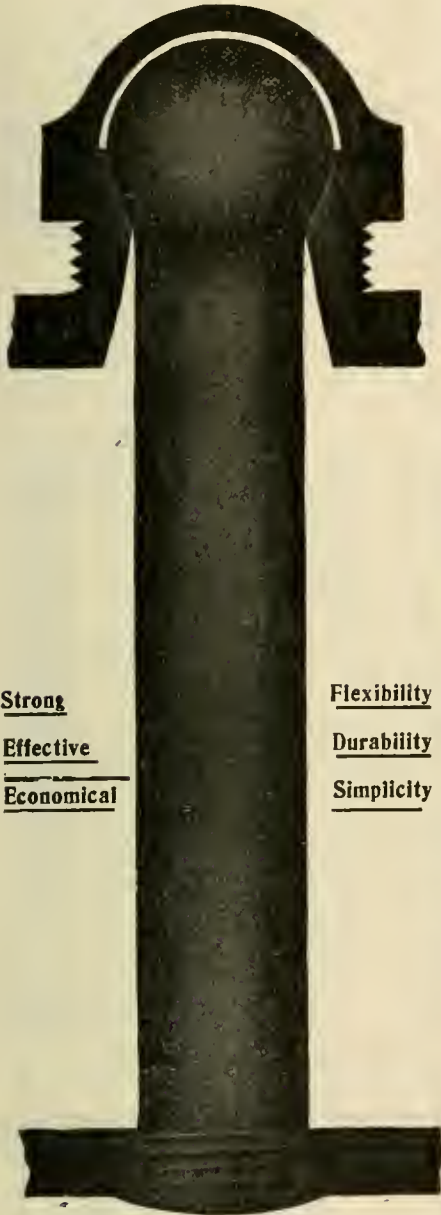

Strong  
Effective  
Economical

Flexibility  
Durability  
Simplicity

Holds firebox sheets securely together, and accommodates itself to the unequal expansion of the plates.

## FLANNERY BOLT COMPANY

PITTSBURG, PA., U. S. A.

Sulte 308, Frick Bldg.

D. E. D. STAFFORD, - - General Manager  
Write us for Reference Book

running time of trains over this stretch of track will be materially reduced.

Between Knightsville and Terre Haute, nine reinforced concrete subways will carry wagon roads under the railroad tracks and two roads will be carried over the tracks on reinforced concrete bridges, eliminating eleven grade crossings in 14 miles. In addition to this, about a mile of second track is being built between the west end of the Wabash river bridge, Terre Haute, Ind., to Macksville. This improvement will necessitate no masonry. The earthwork will approximately amount to 200,000 cubic yards, and will be in the form of an embankment.

### Square Deals in Oil.

When the movement for the economical use of locomotive supplies began to be seriously taken up by railway companies, there was a good deal of fun made of it in various quarters. Some people even now refer to it as the "oil

alongside of the rack piston-rod, and parallel to it is an upright rod upon which there are several fingers which are held in place each by a screw, but each finger is set at a different angle, and they are placed at different heights. The lower end of this upright rod with the fingers, terminates in a handle by which the rod can be revolved about its axis, and any desired one of the fingers can be swung round so as to stop the upward movement of the piston rod at a particular place. The handle of the upright rod moves over radial lines on a dial so that the amount to be drawn off is indicated by the position of the handle.

Suppose you want to draw off half-a-gallon of oil. The handle is set at the half-gallon mark, and that swings the corresponding finger on the rod into position; then the crank handle of the pump is turned and up comes the rack piston-rod and the oil flows out. As soon as the bottom of the rack which carries a



AN ARTISTIC STUDY OF CLOUD EFFECTS.

famine period." With the economical use of oil there necessarily grew up a system of careful oil measurement, which was more or less accurate according to the method followed. At the present time one of the neatest and most accurate devices for supplying oil that we have seen is that known as the Bowser self-measuring oil outfit. From our inspection of it we would be inclined to call it the Square Deal Oil Pump. It measures the oil as used, gives the exact quantity required and registers the total amount drawn off.

The pump consists of an upright cylinder fitted with a piston, the stem or piston-rod of which is made in the form of a toothed rack and the handle for operating the pump is a crank with a gear wheel at the centre, and this gear engages with the rack and a few turns of the crank handle will draw the piston up in the cylinder and force the oil out through the delivery pipe. Standing

lug reaches the half-gallon finger, the rack piston-rod is stopped and it can go no further. Half-a-gallon of oil has been poured out and the upward movement of the rack piston-rod has at the same time counted half-a-gallon on the registering dial, and you have drawn off just half-a-gallon, neither less nor more, and you have automatically registered the operation.

Suppose the oil man has filled a hundred requisitions for all sorts of small quantities within any given time, the total of all the requisitions is shown on the dial and the oil accountant (if we may call him so) reads the dial in the same way that the gas man reads your meter. He has the reading before any oil is drawn off and at the end of the day he has the total shown on the dial, and the previous figures subtracted from the present gives the amount drawn off between readings. No one can be given a little more than he should receive if the

plunger reaches the stop, and if the oil man is "selling short," the meter tells the tale when the readings are taken. The pump can be readily locked so that when the oil man has the key in his pocket the oil is safe, and that is all about it.

This oil measuring device is, as we have intimated, a very ingenious device. It is made by S. F. Bowser & Co., Inc., of Fort Wayne, Ind., and they have issued a very fully illustrated catalogue showing their oil storage systems and the oil pump which we have described. If you are interested in the Square Deal idea as applied to oil handling write to them for a copy. It is free for the asking.

An officer of the Pennsylvania recently stated that the prizes to be awarded this year to supervisors for superiority of track will aggregate a large sum. Competition for these awards has been keen. Last year about \$9,200 was thus distributed. A number of the eastern divisions have already been inspected, and the remainder soon will receive attention from the president and other officials.

#### Thor Hose Coupling.

One of the handiest hose couplings for shop use is that made by the Independent Pneumatic Tool Company, of Chicago, and called the "Thor" hose coupler. The device, which is shown in our illustration, is made of tough bronze and will stand hard usage and will not rust. There

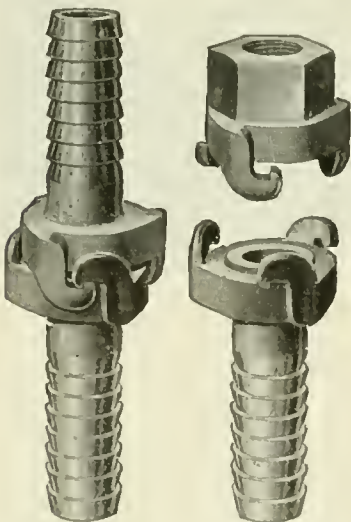

AIR OR WATER HOSE COUPLER.

are three hook-shaped lugs, and giving them a third of a turn makes all engage and the coupling is tight. They are made for 1 in.,  $\frac{3}{4}$  in.,  $\frac{1}{2}$  in. and  $\frac{3}{8}$  in. hose or pipe with the same sized head so that large hose can be coupled to small hose without using reducers. If a piece of  $\frac{3}{4}$  in. hose bursts and you have a length of 1 in. lying idle, you can put the large size "in circuit," as electricians say, and go on with your work. There are no rights and lefts, every coupling couples to every

other. There are only two patterns, one is for the piece which screws on the iron pipe and the other is the hose coupling. Write to the company for further particulars if you are interested.



RESULT OF A RUN OFF.

#### Wants M.M. Ass'n. to Provide Fund.

At a meeting of the Executive Committee of the American Railway Master Mechanics' Association on the eve of last convention, a communication was read from Professor Goss, of Purdue University, offering to carry out certain experiments on locomotives under the auspices of the association, the expenses of which to be paid for by the association. Professor Goss recommended that the association should provide an annual fund of \$2,000 to \$5,000 to defray the expense of scientific researches to be carried out at Purdue University.

The subjects recommended for immediate investigation were:

1. An experimental study of different types of superheaters which will serve as the basis of formulas which may be used in proportioning the superheating to the direct heating surface for the purpose of giving any desired degree of superheat.

2. An experimental study of the strain in the moving parts of a locomotive at speed.

3. Tests to determine the relative adaptability of various low grade fuels for locomotive service.

4. A study of the possibilities of automatic stoking in locomotive service.

The Executive Committee did not view with favor the idea of the association asking railroad companies to defray the expenses of experimental work and nothing was done with the application.

#### Record of Recent Construction.

"The Steam Locomotive of the Future" is the title of Baldwin's Record of Recent Construction, No. 61. It is from the pen of Mr. Lawford H. Fry and originally appeared in Cassier's Magazine. Ten examples of powerful high-speed locomotives are given and these are typical of the most advanced practice in Great Britain, France, Germany, Switzerland and America. Each type is described and while the fullness and fairness of the descriptions are particularly marked, Mr.

A practical demonstration of the advantages of the **BLISS SYSTEM** of **ELECTRIC CAR LIGHTING** will be given at **ATLANTIC CITY**

During Convention Week (June 12th to 19th) we shall be glad to have all interested in the subject of electric car lighting visit our exhibit on the Steel Pier—Spaces 1,201 to 1,207, inclusive. We shall have there complete Bliss car lighting equipments operating under actual service conditions.

Each separate part of our equipments will also be exhibited in detail, affording railroad men an opportunity to acquaint themselves with the construction and operation of the best system of axle lighting yet devised.

The following representatives of our Company will be on hand to welcome visitors and to explain to them the operation of the Bliss System:

W. L. BLISS,  
JOHN L. BLISS,  
COL. JNO. T. DICKINSON,  
WM. L. LALOR,  
ROBERT C. SCHALL,  
F. URBAN,  
E. B. H. TOWER, JR.

#### Bliss Electric Car Lighting Co.

Main Office and Works, MILWAUKEE

New York Office:  
NIGHT AND DAY BANK BLDG.

Chicago Office:  
MONADNOCK BLOCK.

Those who are not going to the Convention should send for a copy of our Bulletin 30, which is the next best way of becoming acquainted with the merits of the Bliss System.



## Locomotive Blow-Off Plug Valves

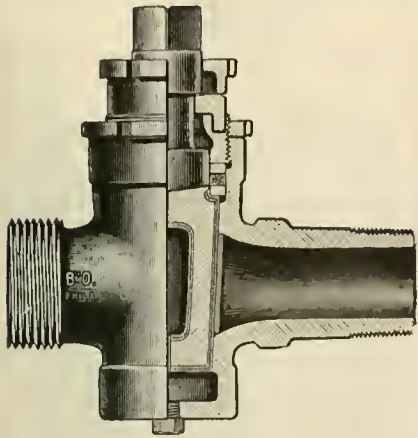

All Brass, extra heavy, with Cased Plug.  
For 250 lbs. pressure.  
Made with Draining Plug to prevent freezing.



## LOCOMOTIVE GAUGE COCKS

For High Pressure

Bordo Self-Closing Gauge Cocks, made with renewable Hard Bronze seat and disc. Opened and closed with a quarter turn. Guaranteed Steam tight under the most exacting conditions. Shanks Threaded to specifications for Locomotives.

Seats and discs replaced under pressure.

## Swing-Joints and Pipe Attachment



May be applied between Locomotive and Tender.  
These Swing-Joints are suitable for Steam, Gas, Air, Water or Oil.

Complete Booklet on Application

**L. J. BORDO CO.**  
PHILADELPHIA, PA.

Fry shows a decided preference for the high pressure four-cylinder balanced compound class, and claims that it is imperative to use high pressure and a long expansion, and from the point of view of economy steam cannot be so efficiently used in a single cylinder as in two or more cylinders. In regard to the special features of new kinds of valve motion, and of the use of superheated steam, Mr. Fry claims that they have not yet secured a sufficiently wide approval to remove an estimate of them entirely beyond the field of speculation. The locomotive of the future, according to the author of the paper, for high speed will be a four-cylinder balanced compound. The low-speed service and where the power required is not excessive, excellent results can be obtained with a single expansion engine working with superheated steam.

### B. of L. E. Convention.

About the middle of last month the Brotherhood of Locomotive Engineers held their annual convention in the historic old city of Quebec. Between five and six hundred delegates, accompanied by their families, assembled in the ancient capital of Canada. There is much of interest for the visitor in Quebec. The narrow, quaint streets, the Dufferin Terrace, the old gate, and the famous citadel crowning the heights of Cape Diamond are all of the old world, and contrast pleasantly with the more modern surroundings. Quebec is reached by the Canadian Pacific, the Grand Trunk and the Intercolonial Railways. A more delightful and interesting spot for holding the Locomotive Engineers' convention could not well be found, and the visitors from this side of the international line enjoyed to the full the free-handed Canadian hospitality.

### Railroad Building and Irrigation.

Government reclamation of the arid lands of the West is the cause of the building of the line constructed from Hazen, Nev., to Fallon. The new road is a branch of the California and Nevada line of the Southern Pacific System. At present, with the exception of two miles near Fallon, the road passes through desert land, but the government irrigation work will soon turn this territory into a rich agricultural section. The Truckee irrigation project, when completed, will provide a supply of water sufficient to irrigate 350,000 acres of land in Western Nevada. It includes the Carson sink country, which, the government experts say, will make exceptionally fertile farming land as soon as water is available.

The main feature of the work is a canal 30 miles long to divert water from Truckee river to the channel of Carson river, where a storage reservoir is to be

built. This canal, with several hundred miles of lateral ditches, has been completed, and water is ready for delivery to about 50,000 acres; 30,000 of which are public lands open to homestead settlement. When the settlers come they will find the Hazen-Fallon Railroad ready to distribute their products to the surrounding mining districts, which will naturally be their market. The railroad is of great assistance to the reclamation service in transporting supplies and materials.

### Curious Invention.

A North Carolina inventor has patented a somewhat singular device intended to lessen the impact of collisions on railways. A coiled spring is secured in a casing on the front end of the locomotive and kept in retracted position by a locking handle which has a connection extending to the engine cab. When the engineer sees that a collision is inevitable he lets loose the spring and a corkscrew projects itself fifteen or twenty feet in front of the



CAB AND TANK LOADED UP.

locomotive. When the blow struck by the locomotive occurs, it is supposed to be almost entirely neutralized in coiling up the spring. It looks great—on paper.

### Eight-Wheel Type Passenger Engines.

A pamphlet recently issued by the American Locomotive Company illustrates and describes different designs of 8-wheel or the 4-4-0 type passenger locomotives. This is the eighth of the series of pamphlets which is being issued by this company covering the various standard types of locomotives. It contains illustrations of twenty-five different designs of 8-wheel type engines, the principal dimensions of each design being given on the page opposite the illustration. The pamphlet constitutes a very complete record of the production of the company in this type of engine, and the arrangement is very convenient for the selection of a design best suited to meet particular requirements. A copy of this pamphlet may be had by direct application to the company.

**Packing Ring Chuck.**

The device illustrated herewith shows a chuck which is bolted fast to the face plate of an ordinary boring mill and used to face down air pump piston packing rings to exact width.

This operation is very necessary and requires a great deal of skill in order to make the rings properly fit the grooves in the piston head.

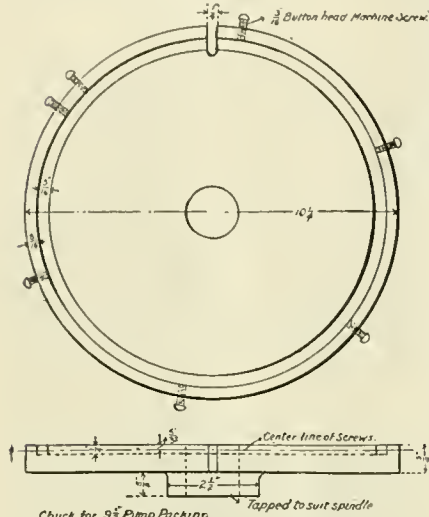

**PUMP PACKING-RING CHUCK.**

This chuck was worked out by one of the foremen in the Hornell shop, and is now in use in practically all the shops on the Erie. Its greatest utility lies in the fact that when the ring is finished it is precisely the same thickness at all points, and therefore perfectly fits the piston head.—*Erie Railroad Employees' Magazine.*

**A Pilgrims' Railway.**

The Mecca line is being well built under the supervision of a German civil engineer by Ottoman soldiers, the cost defrayed by voluntary contributions from Moslems in all parts of the world and by special taxes. It is known as the Hamidieh-Hedjaz Railroad, and consists of the main line from Damascus toward Mecca, which is completed beyond Tabuk some 560 miles, costing about \$7,500 a mile, and the Haifa-Derah line of 103 miles, costing about \$12,000 a mile owing to the more irregular surface of the ground. The latter branch is finished and in full operation. On the main line and that of Haifa, both of which are of the narrow gauge type, there are so far 2,388 bridges of stone and six of metal. Eight tunnels have been driven, and at the principal stations large storehouses and repair shops have been constructed and water supplies established. The rolling stock employed is of Belgian and German origin, while a large portion of the rails were brought from America. It is expected that the main line will reach Medina in a year or more and Mecca

early in 1910. At present trains run regularly as far as Tabuk.

**Water Softening.**

The question of procuring satisfactory water for use in the boilers of locomotives has been a more or less serious question with the majority of the railroads in the United States. The advantages of having soft water for use in locomotive boilers is so obvious as not to need argument. Many railroads have found it advantageous to install water-softening plants and among the manufacturers of this class of railway equipment may be mentioned the Otto Gas Engine Works, of New York and Chicago.

It is believed that about 98 per cent. of the scale formed upon boiler tubes is caused by deposits of carbonate of lime, carbonate of magnesia, sulphate of lime and sulphate of magnesia; and that by eliminating the action of these four substances scale trouble practically ceases. The advantages of having good water are such that not only is a large saving effected in round house expenses, but coal consumption is reduced, the life of the locomotive is prolonged, the time spent in round house repairs is reduced, and the earning power of the locomotive is increased.

The water-softening plant as built by the Otto Gas Engine Works is said not to be a complicated or expensive apparatus to operate, the mixing of the chemicals is automatic, and is done with accuracy and without the use of any additional mechanical power, while the attendance required on a water-softening plant is not increased beyond that required for the ordinary pumping station. Many prominent lines have installed this apparatus. The Otto Gas Engine Works have published an interesting pamphlet on the subject and are prepared to furnish details and estimates of either the intermittent or the continuous systems, as applied to water softening.

The United States Congress has always displayed decided lovingkindness in the passing of acts that would influence the express companies. Express companies exist, become rich and prosper, because they are permitted to monopolize carrying business which by right belongs to the post office department of the government. The real reason why express companies are not compelled to act fairly toward the public is that many congressmen are interested in the securities of the companies.

The Courts have decided that when a passenger has been put off a train or car because the conductor failed to have change for a five dollar bill, there is a clear case of damages against the carrying company

**Homestead Valves**

**Straightway, Three-way and Four-way, and**

**Homestead Locking Cocks**

**Are Famous the World Over**

They cost more, but are worth very much more than other makes. You try them and see.

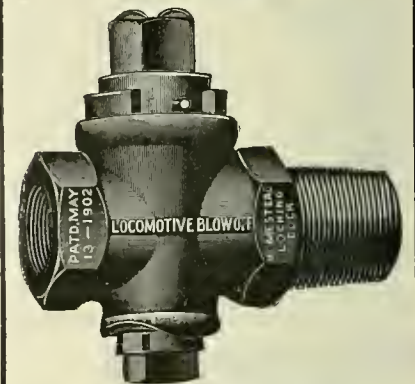

**HOMESTEAD VALVE MFG. CO.**

**WORKS: HOMESTEAD, PA. PITTSBURG, PA.**

**American Locomotive Sander Company**

13th & Willow Sts., Philadelphia, Pa.

Proprietors and Manufacturers

LEACH, SHESBURN, DEAN, SANDERS  
HOUSTON, "SHR" and CURTIS

**THE ROBERT W. HUNT & CO.**  
Bureau of Inspection, Tests and Consultation,  
1137 THE ROOKERY, CHICAGO.

66 Broadway, New York.  
Park Building, Pittsburg.  
31 Norfolk House, London, Eng.  
Inspection of Steel Rails, Splice Bars, Railroad Cars, Wheels, Axles, etc. CHEMICAL LABORATORY—Analysis of Ores, Iron, Steel, Oils, Water, etc. PHYSICAL LABORATORY—Test of Metals, Drop and Pulling Test of Couplers, Draw Bars, etc. Efficiency Tests of Boilers, Engines and Locomotives.

# One Year and Eleven Months' SERVICE

WITHOUT REPACKING, ON

## High-Pressure Locomotives

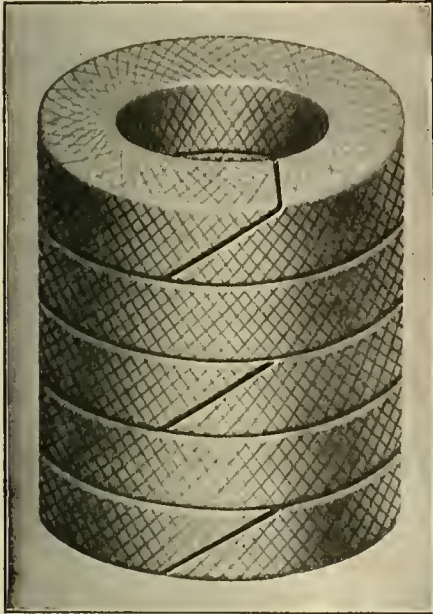

Style 300 TV.

A throttle failure is an absolute impossibility where Crandall's Throttle Valve packing is used.

IT WILL NOT BLOW OUT

## Crandall Packing Co.

FACTORY AND GENERAL OFFICE  
PALMYRA, - - NEW YORK

BRANCHES

New York Cleveland  
136 Liberty St. 9 So. Water St.

Chicago

52 West Washington St.

### Consume Your Own Smoke.

Dr. William Osler in one of his addresses to the young men of the medical profession says some things which are true of things as we all find them in the world, and they are as applicable to us of the railroad fraternity as they are to young doctors. He says: "A conscientious pursuit of Plato's ideal perfection may teach you the three great lessons of life. You may learn to consume your own smoke. The atmosphere is darkened by the murmurings and whimperings of men and women over the non-essentials, the trifles that are inevitably incident to the hurly-burly of the day's routine. Things cannot always go your way. Learn to accept in silence the

### Mr. Harrison Emerson on Individual Effort.\*

"The more I see of piece work," said Mr. Emerson when addressing the General Foremen's Convention in Chicago, "the more I feel like expressing myself as Ouida, the woman novelist, does when she says the more she sees of men, the more she likes dogs, and the better I become acquainted with piece work, and the more I see of it, the better I like something else. We had some experience on the Santa Fe which will illustrate why piece work was considered a great advance over the old day work system. At one of the western shops out in the mountains, where it was very difficult



WELL DRAINED PENNSYLVANIA TRACK.

## Directory of Railways of the World

The Universal Directory of Railway Officials, published in London, contains a list of the entire railroads of the world, with physical particulars and names of all officials.

Send Your Order Now

for the 1906 edition.

Price \$3.00 Prepaid

A. FENTON WALKER

Sole Representative for U. S.

143 Liberty St. New York

minor aggravations, cultivate the gift of taciturnity and consume your own smoke with an extra draught of hard work, so that those about you may not be annoyed with the dust and soot of your complaints. More than any other, the practitioner of medicine may illustrate the second great lesson, that we are here not to get all we can out of life for ourselves, but to try to make the lives of others happy. Courage and cheerfulness will not only carry you over the rough places of life, but will enable you to bring comfort and help to the weak-hearted, and will console you in the sad hours when, like Uncle Toby, you have "to whistle that you may not weep."

to regulate conditions, the men were employed at a fixed rate that applied to them as machinists, boilermakers or blacksmiths, and the management was very particular about this fixed rate, very particular that the men should be employed strictly at the standard rate of pay. The timekeepers were also very particular that these men registered in at seven o'clock in the morning by means of a clock, and also that they registered out at six o'clock in the evening, because they didn't propose to pay any man who had not registered at seven and registered out at six o'clock. The third thing that

\*Original paper on page 304 of this issue.

they were very much concerned about was that the time they were paid for should be accurately distributed to the different engine numbers or shop orders, or other branch of work upon which they were engaged. In this way a correct record was kept of all work done, and if you asked a man perhaps on Monday what he had done the previous Friday, he would look up and see that he had worked five hours on engine 105, and he had worked five hours on something else. Actual facts are known where many of these men had registered in at seven o'clock in the morning, had then invested in a keg of beer, and climbed on the engine and run down the road about two miles to an Indian village, where they spent the day, not coming back until about 5:30 in the evening, in time to register out. Of course they had not done any work at all. By this process the company was getting no results whatever for the money that they paid out in wages, and it was not very satisfactory to the employer. Any method that gave to the employer some kind of an equivalent for the wages he paid seemed preferable to the old day rate system. The trouble was, however, that the employer kept his eyes fixed upon the amount that the men earned. The introduction of piece work was objected to by a great many workers, and I think very justly. They saw in it a plan to get them spurred up to the utmost limit, and an endeavor to keep down the rate of pay to a minimum, so that the employer was constantly trying to get more work out of the men and possibly scheming to pay him less.

"I recently visited a shop in the East where piece work prevailed, and I found that the management considered that a certain definite sum was the proper amount that a man should be permitted to earn. He had no business to earn more than \$10 a week, let us say, and if by any chance the poor man earned \$10.05, then they immediately began to scheme to see whether they could not cut down his piece work rate so as to bring him down to \$10 and get more out of him, and the men who had developed unusual and extraordinary skill by working in the same shop for a great many years found themselves, as they were growing old, pressed down to a limited rate of pay by the constant changes that the management put in with reference to the piece work rate, the one idea of the management being to establish that kind of a rate which would make it impossible for a worker to earn more than \$10 a week. In checking over the rates of this man week after week, I would find that one week he would make \$9.97, and the next week it would be \$9.98 and the

next \$10.02; then, perhaps, it would go up to \$10.15, and the man, in fear and trembling, would work along during the next week and see that he had his wages down to \$9.85, for fear they would use that particular occasion when he had earned 15 cents more to cut down his piece work rate. Now, that kind of treatment of a worker, that kind of attempt to rob him of what rightfully belongs to him, is absolutely wrong. That is the kind of thing that has brought piece work into disrepute among wage earners, and has equally brought it into disrepute among employers, who think there should be a fairer and better way.

"Another objection to piece work is that if it is established, and if the management agrees not to change the rates, you may be giving the worker a great deal more than he is personally entitled to. For instance, in one of the Southern Railroad shops, in which piece work was introduced a few years ago by Mr. Cozad, I believe, who is one of the most skilled and experienced piece work experts in the United States, especially in railroad work, the piece work rates were put in before the introduction of the high speed steel. Later on, when the high speed steel was introduced and new machines were bought, and it was found possible to cut the time of turning tires from, say, eighteen hours down to three or two hours, the men simply stood up and refused to have the piece rate lowered. Now, the cutting of the time due to the introduction of high speed steel and modern machinery was not due in any way whatever to the efforts of the men working on the wheel lathes, if that be the tool used, as an example. Or, say the management that had to pay for this high speed steel had to put in heavier machinery, and there was a reduction in price which legitimately belonged to the management. It would have been impossible for that concern to have paid the extraordinary and unreasonable wages that the men were earning when they were getting the same pay for two and three hours' work that a year or two previous to that time they had received for eighteen hours' work.

"On the other hand, when a man does, through his own efforts, acquire extraordinary skill, it is wrong on the part of the employer to rob him of what belongs to him individually, simply because that man does not know where else he will go and get a job in order to support himself and family, and, therefore, is bound to accept an outrageous cut in his rate of pay.

"Two or three years ago Mr. Cozad went to the Erie Railroad and put in piece work on that system. About the

## The Twentieth Century Master Mechanic

Won't use Solid Mandrels.  
Cost too much, take up too much room and don't give satisfaction.

### Nicholson Expanding Mandrels

Take everything from 1 to 7 inch holes. Take up little room—always ready and you can buy four sets for the cost of one of the solid kind.

### Are You Using Them?

Catalogue tells you more about them.

**W. H. Nicholson & Co.**  
Wilkesbarre, Pa.

**Fifth Edition,  
Revised and Enlarged**

Number of pages increased  
from 617 to 946, and figures  
from 309 to 494.

**Price, \$3.50**

**LOCOMOTIVES:  
SIMPLE,  
COMPOUND,  
AND  
ELECTRIC**

By **H. C. REAGAN**, Electrical Engineer

Send for  
Descriptive Circular

**JOHN WILEY & SONS**  
43 and 45 E. 19th St.  
NEW YORK CITY

**THE TANITE CO.**  
**seeks the support of**  
**Railroaders because:**

The man who uses a TANITE wheel will find it safe. Because pay for a TANITE wheel secures the greatest productive capacity. Because TANITE MILLS EMERY is mined in America and appeals to all who earn wages in America. Because TANITE grinding machines are practical.

THE TANITE CO. sells Emery, Solid Emery Wheels, Buffing Lathes, Guide Bar Grinders, Car Brass Grinders, Bench and Column Grinders, Surfacing Machines, Open Side Emery Planers, Saw Gummers, Automatic Planer Knife Grinders, Diamond Tools, Polishing Paste for Brass and Nickel, Emery Wheel Cutters and Dressers.

*The Tanite Co. builds special machines for special wants*

**THE TANITE CO.**  
**STROUDSBURG, PA**

**THE UNION**  
**SWITCH & SIGNAL**  
**COMPANY**

CONSULTING  
 AND MANUFACTURING  
 SIGNAL ENGINEERS

Automatic Block Signals—Electric and Electro-Pneumatic

Interlocking — Electric, Electro-Pneumatic and Mechanical

Electric Train Staff Apparatus

General Offices and Works at  
**SWISSVALE, PA.**

DISTRICT OFFICES:

- NEW YORK - - 143 Liberty Street
- CHICAGO - - - Monadnock Block
- ST. LOUIS - - - Frisco Building

**Oliver Lippincott**  
**Photographer**

20 John Street, New York

Process and Mechanical Prints

Perfect reproduction from Tracings, Black Lines, White Paper, any size, for Specifications and Estimates.

same time we began to put the Individual Effort System on the Santa Fe. Mr. Cozad and myself conferred about the matter. He came down to Topcka and we examined our method closely, and I went back to the Erie Railroad at Meadville, visited the shops there and examined their system there. We agreed to disagree. Mr. Cozad was still in favor of piece work, and I was in favor of a more modern method than piece work. Of course, piece work was an improvement over the old method, but yet, as time went on, there were better methods even than piece work.

"I would just like to compare the results obtained on the Santa Fe and the Erie at the end of three years, the one under the Individual Effort System and the other under the Piece Work System. Both these sets of figures are taken from the annual reports of the two roads issued over the signatures

Fe the repairs and renewals were \$0.096, while on the Erie 12 cents; decrease on the Santa Fe of 23 per cent, increase on the Erie of 6 per cent.

"On the Santa Fe repairs to locomotives per ton of fuel burned (and this is perhaps the fairest estimate that you can make of the amount of repairs that should be allowed on a locomotive, because fuel differs in grade, engines differ in size; then there is the weather and season that have to be taken into account) were \$1.10, and on the Erie \$1.64.

"It therefore seems to me that, in this comparative and amicable test that has been made of these two great railroad systems between these two different methods, both of them introduced at the same time, both of them running their course through the same number of years, results vary greatly in favor of the Individual Effort System that was applied on the Santa Fe,



ENGINE SWITCHING CARS IN WAVERLEY GARDENS, EDINBURGH, SCOTLAND.

of their presidents. I shall compare the two fiscal years, 1904-5 and 1905-6 for both railroads.

"Transportation on the Santa Fe showed an increase of 10 per cent, on the Erie it remained stationary. Locomotive mileage on the Santa Fe increased 12 per cent, on the Erie it increased 2 per cent. Locomotives repairs on the Santa Fe decreased 14 per cent; i.e., that with 12 per cent more mileage there was 14 per cent less expense. The Erie locomotive repairs increased 4 per cent. Tools and shop machinery on the Santa Fe decreased 24 per cent absolutely, in spite of the very large increase of business. The Erie tools and shop machinery increased 74 per cent. Repairs and renewals per mile for locomotives on the Santa Fe were \$0.096. Our locomotives are, as you know, heavier than those on any railroad in the United States. We have a great many of the big Santa Fe compounds and other heavy types, while the engines on the Erie are not as heavy in proportion. On the Santa

rather than in favor of Piece Work that was introduced on the Erie."

Answering a question put by Mr. Fay as to what, in his judgment, causes the difference between the Piece Work System on the Erie and the Individual Effort System on the Santa Fe, and where does the difference comes in, Mr. Emerson replied: "The great difficulty, of course, either in the Piece Work System or in the Individual Effort System is to establish a fair and proper rate. Now, there is virtually no difference between the Individual Effort System and the Piece Work System, if you can in either case establish that fair rate and have the men accept it. We first make a very careful study of what the rate or the time ought to be. We eliminate what is, in other words, unnecessary waste of time, and we get down to what is standard time. In demonstrating how we get at the standard time, I will tell you a little anecdote that applies to a western shop in the neighborhood of Meadville, Pa.

"My brother was in that shop when

they were making repairs to an engine, and the manager was not particularly pleased to have him there. He considered it somewhat of a reflection upon his own ability as a manager that a man should be brought from the Santa Fe to make any report on that job. He said to my brother: "There is a machinist that I consider a first-class man. I want you to tell me what you can suggest about his work and see if you can better his time. I pay that man 25 cents. The man was finishing a piston rod. He was doing a very careful, good workmanlike job. There was no criticism of any kind to be made, and it took about thirty-five minutes to run the length of the piston rod. Then he wanted to throw the piston rod out of the lift, and he began to look around for a chain with which to lift it off. There was none handy, and he spent about fourteen minutes hunting for one. He finally came back with one, but when he went to use it, he thought that the rough chain would scratch up his piston rod, so he went off to look for a pad. He was gone eight minutes looking for that pad. The man required only thirty-five minutes to do the work, but the time he actually took was fifty-seven minutes. The efficiency of that man was somewhere in the neighborhood of 62 per cent, instead of 100 per cent, as it ought to have been. We consider any man that does not reach an efficiency of 66 per cent as very undesirable, a kind of a mollycoddle. This time spent in hunting around for something is what we call the unnecessary waste of time. Now, the great difficulty that you have with the worker is that he does not know in how short a time he can do it, and if you tell a man that he ought to do a certain job in a certain length of time he comes back at you in rather strong language.

"What we do is this—we begin our bonus at 50 per cent higher time than is reasonable. If we think that a job ought to take four hours, we tell that man we will begin your bonus at six hours. We are paying you the day rate in any event. You try hard, and if you don't make it in six hours, and it takes you seven hours, all right, you are getting your day rate and are not the loser. He tries his very best, gets down to six hours, then he gets down to five and one-half hours, and then we give him a little bonus. After he has once started it is up to him to make all there is in it. There is no stopping place for him. Did any of your men ever try to get a calf to drink skimmed milk? I have had some experience. If you have, you know how you have to push and drag it up to the pail, hold onto its tail, force its head into

the pail, slop the milk up into its mouth and keep patting it with your hands, but after it has once started it is hard work to get its head out of the pail. Bonus work is about the same kind of a job. There is really a great deal of difference between the Individual Effort System and the Piece Work System, in that we have a very much easier way of sliding men into a standard rate than you have where you are paying piece rates."

#### Self-Grinding Valve.

The Swenson Valve Company of Decorah, Iowa, have placed on the market a very clever device in globe valves whereby each time that the valve is opened or closed a slight grinding takes place, with the result that the disc and seat are kept in perfect contact and leakage is eliminated. The operation is made possible by a movable nut in a chamber in the bonnet, the valve-stem engaging with the nut instead of with the fixed bonnet as usual. When the disc reaches the

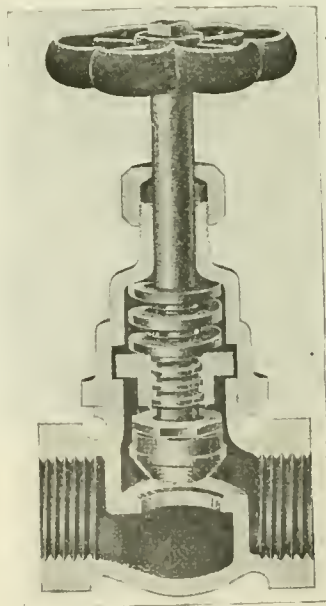

SELF-GRINDING VALVE.

valve seat, the stem can still be turned, as the space in the bonnet admits of the nut rising up from the disc. On this nut a coiled spring is set and the grinding of the disc and seat occurs under the pressure of this spring. The valve is admirably suited for boiler head attachments and is coming into popular favor. The veteran railway supply man, Mr. Charles Law of Pittston, Pa., is agent for the Eastern States.

Peace, obedience, faith; these three for chief good: next to these the habit of fixed attention, with both eyes and mind: lastly, an extreme perfection in palate and all other bodily senses. Such I esteem the main blessings of my childhood.—*Ruskin.*

### STANDARD MECHANICAL BOOKS FOR ROAD AND SHOP MEN BY CHAS. McSHANE.

#### The Locomotive Up to Date

Price, \$2.50

#### New York and Westinghouse Air Brakes

Price, \$1.50

#### One Thousand Pointers for Machinists and Engineers

Price, \$1.50

All books bound in fine cloth.

AGENTS WANTED everywhere; write for terms and descriptive circulars. Will be sent prepaid to any address upon receipt of price.

### GRIFFIN & WINTERS

171 La Salle Street, CHICAGO

# TOOL STEEL

Die Blocks  
Steel Forgings

First Prize awarded at the Louisiana Purchase Exposition, at St. Louis, for our TOOL STEEL when placed in competition with the best makes in England and Germany.

Write for Information and Prices.  
Specify McInnes Tool Steel when ordering.

# McINNES STEEL CO.

CORRY, PA.

*Perfect*

Why pay more for a Car and Locomotive Cleaner, when the "PERFECT" will do the work and better at 48 cents per gallon, f. o. b. Philadelphia or Chicago?

---

THE MODOC SOAP CO.  
228 North Fourth Street  
PHILADELPHIA, PA.

**MICA**  
CABOOSE LAMP CHIMNEYS

Save 50 per cent.

STORRS MICA CO.,  
R. R. Dept. Owego, N. Y.



REGISTERED TRADE MARK



PATENT NO. 818,400

PAT. NO. 488,177		PAT. NO. 654,541
** 800,899		** 654,542
** 634,104		** 725,368
** 802,820		** 775,194
** 772,169		** 724,490

**NO MORE BILLS for PACKING**

No Cutting of Rods  
Less Oil. No friction

Guaranteed 3 years. 30 Days' Trial  
No Pay unless Satisfactory  
Beware of Imitations. Use the Best

Manufactured only by  
**Holmes Metallic  
Packing Company**  
Wilkes-Barre, Pa.  
See also Catalogue K

**Oil Burning in Locomotives**  
Is described in our new book  
**Care of Locomotive Boilers,**  
50c. - - This Office

**Double Seated Gauge Cock.**

The double seated locomotive gauge cock manufactured by the L. J. Bordo Company of Philadelphia, Pa., an illustration of which is here given, is a device which fills a long felt want. Where this device is used it is not necessary to draw the fire to repair a leaky gauge cock, as repairs may be made under pressure, thereby effecting a consider-

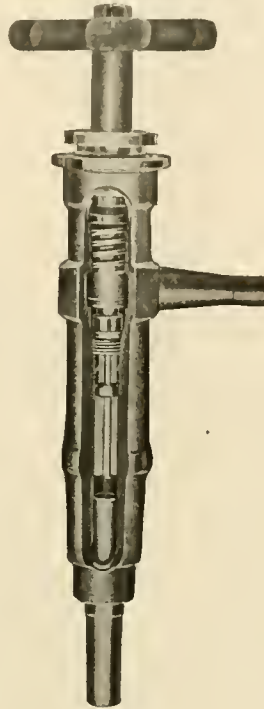

DOUBLE SEATED GAUGE COCK.

able saving in time at roundhouses and terminals. When the lock nut is released the gland may be unscrewed and the spindle removed, while the pressure is on, the valve closes the opening to the boiler and so shuts off the pressure. Should it happen that the seat is cut, a socket wrench is provided for removing it and a new seat may be inserted. The disc applied to the spindle is also renewable and can be taken out by the use of an ordinary monkey wrench. Both seat and disc can be removed in a few seconds. The company will be happy to give further information by letter or otherwise to anyone who is sufficiently interested to apply to them.

**Nervous Wear in the Cab.**

A great deal of senseless gush is written about the physical strains that ruin the nerves of locomotive engineers in a very few years. If a man is of good habits and possesses a sound constitution his body, nerves and co-ordinate members soon adjust themselves to the strains of the business. The people who write concerning the ruinous strains of running fast locomotives are people unaccustomed

to life in the cab and they are shocked by the excitement of a flying trip.

Every through railroad in the country has men daily running express trains who suffer no more from nervous tension than the man driving his own buggy over quiet country roads.

**Odd Cause of Thunder.**

Thunder, just because it is a noise for which there is no visible cause, has always excited the imagination of the unscientific; so it is natural that the most outrageous superstitions about storms should date back to the time when everybody, more or less, was unscientific. One old writer explains the belief of his day—that "a storm is said to follow presently when a company of hogges runne crying home," on the ground that "a hogge is most dull and of a melancholy nature, and so by reason doth foresee the raine that cometh." Leonard Digges, in his "Prognostication Everlasting" (1556), mentions that "thunder in the morning signifies wind; about noon, rain; and in the evening, a great tempest."

"Here!" shouted a railway official, "what do you mean by throwing those trunks about like that?" The porter gasped in astonishment, and several travelers pinched themselves to make sure that it was real. Then the official spoke again to the porter: "Don't you see that you're making big dents in this concrete platform?"—*Montreal Witness.*

**CONTENTS.**

Modern Mountaineer, The.....	299
Steel as an Engineering Material, by W. S. S. ....	301
*General Correspondence .....	307
*Increase in Railroad Equipment.....	317
Mechanical Engineers .....	318
Correspondence School .....	319
Questions Answered .....	321
*Patent Office Department .....	322
*Air Brake Department.....	323
*Electrical Department.....	325
*London's Latest Tube.....	326
Railroading Under Difficulties. Sam Rarus.	329
Personals .....	331
Improvements on the Vandalia.....	338
Square Deals in Oil.....	339
B. of L. E. Convention.....	341
Railroad Building and Irrigation.....	341
General Foremen's Association:	
Individual Effort. D. E. Barton.....	304
Stores Department and Shops (Committee) ..	311
Roundhouse Ventilation. J. W. Chrysler..	313
The Stores Department (Discussion).....	328
H. Emerson on Individual Effort.....	343
Locomotives:	
*Heavy 2-8-0 on the Big Four.....	309
*Ten-Wheeler, Ulster & Delaware.....	310
*Baldwin 2-8-0 for the Western Pacific....	329
*New 0-8-0 for the G. E. R.....	335
Editorials:	
Thriving on Patents.....	314
Conventions at Atlantic City.....	314
Workshop Words .....	315
Promote Trainmen .....	315
Breakage of Rails.....	315
Fitting a Throttle Valve.....	316
Profits of British Railways.....	317
Shop Kinks and Appliances:	
Magnetic Chip Remover.....	318
*Franklin Air Compressor.....	333
*Thor Hose Coupling.....	340
*Eric Packing Ring Chuck.....	342
*Self-Grinding Valve.....	346
*Double Seated Gauge Cock.....	347

# "PERFECTOL"

The

*Perfect*

Car  
Cleaner

SOLD BY

## The Modoc Soap Company of Ohio

Philadelphia Office: 228 NORTH FOURTH STREET

HENRY ROEVER, Pres. & Mgr.

Why pay more for a Car and Locomotive Cleaner when PERFECTOL at 48 cents per gallon f. o. b. Philadelphia, Cincinnati or Chicago, will do the work and better? Sample furnished free upon application by the proper party.

### INDEX TO ADVERTISEMENTS.

	PAGE.
Acme Machinery Co.....	Front Cover
Ajax Metal Co.....	4th Cover
American Balance Valve Co.....	4th Cover
American Brake Shoe Co.....	14
American Loco. Sander Co.....	292
American Locomotive Co.....	9
American Locomotive Equipment Co.....	4th Cover
American Steam Packing Co.....	13
Armstrong Bros. Tool Co.....	2d Cover
Armstrong Mfg. Co.....	13
Associated Expanded Metal Companies.....	11
Audel, Theo., Co.....	—
Baker, Wm. C., Heating and Supply Co.....	14
Baldwin Locomotive Works.....	8
The Ball Chemical Co.....	26
Ball, Webb C., Co.....	337
Barnett, G. & H., Co.....	2d Cover
Bettendorf Axle Co.....	4
Bliss Elec. Car Lighting Co.....	340
<b>BOOKS.—</b>	
Development of Locomotive Engine.....	—
Miscellaneous Books.....	20
Railroad Men Catechism.....	2
Twentieth Century Locomotives.....	22
Bordo, L. J., Co.....	341
Boston & Maine R. R.....	5
Carpenter, The J. M., Tap & Die Co.....	8
Central R. R. of New Jersey.....	30
Chalfonte Hotel.....	15
Chapman Jack Co.....	16
Chicago & Alton R. R.....	4
Chicago Pneumatic Tool Co.....	11 and 21
The Cleanola Co.....	26
Cleveland City Forge & Iron Co.....	4th Cover
Cleveland Twist Drill Co.....	4th Cover
Columbus Pneumatic Tool Co.....	26
Commercial Acetylene Co.....	10
Consolidated Railway, Electric Lighting & Equipment Co.....	13
Commonwealth Steel Co.....	19

Crandall Packing Co.....	343
Dart, E. M., Mfg. Co.....	17
Davis, John, Co.....	25
Detroit Lubricator Co.....	14
Detroit Seamless Tubes Co.....	10
Dixon, Joseph, Crucible Co.....	334
Dressel Rly. Lamp Works.....	23
Falls Hollow Staybolt Co.....	22
Fay & Egan Co., J. A.....	10
Flanders, L. B., Machine Works.....	11
Flannery Bolt Co.....	339
Franklin Mfg. Co.....	19
Frost Railway Supply Co.....	2d Cover
Galena Signal Oil Co.....	28
Garlock Packing Co.....	2
General Electric Co.....	3
Gold Car Heating Co.....	335
Golden-Anderson Valve Co.....	17
Goodrich Rubber Co.....	25
Gould Coupler Co.....	8
Greene, Tweed & Co.....	2d Cover
Griffin & Winters.....	346
Hammett, H. G.....	4th Cover
Hancock Inspirator Co.....	13
Hendrick Mfg. Co.....	8
Henley & Co.....	336
Hicks, F. M., & Co.....	16
Hoffman, Geo. W.....	8
Holmes Metallic Packing Co.....	347
Homestead Valve Mfg. Co.....	342
Hotel Traymore.....	5
Hunt, Robert W., & Co.....	338
International Correspondence Schools.....	338
Independent Pneumatic Tool Co.....	24
Jenkins Bros.....	4th Cover
Johns-Manville, H. W., Co.....	19
Kinnear Mfg. Co.....	2d Cover
Lackawanna R. R.....	4
Latrobe Steel & Compler Co.....	8
Lima Locomotive Works.....	28
Lehigh Valley R. R.....	7
Lippincott, Oliver.....	345
Locomotive Publishing Co., Ltd.....	11
Long & Allstater Co.....	16
McConway & Torley Co.....	14
McCord & Co.....	2d Cover, 348
McInnes Steel Co.....	346
Modoc Soap Co.....	6
Morse Twist Drill Co.....	—

Nathan Mfg. Co.....	4
National Acme Mfg. Co.....	5
National Malleable Castings Co.....	4th Cover
New York Central R. R.....	15
Nicholson, W. H., & Co.....	344
Niles-Bement-Pond Co.....	—
Norwalk Iron Works.....	16
Otto Gas Engine Works.....	1
Pennsylvania R. R.....	29
Pittsburgh Crushed Steel Co.....	4th Cover
Pittsburgh Spring & Steel Co.....	18
Porter, H. K., & Co.....	9
Pratt & Whitney.....	17
Pressed Steel Car Co.....	13
Prosser, Thos., & Son.....	23
Pyle Nat'l Elec. Headlight.....	18
Railway Materials Co.....	2d Cover
Railway Steel Spring Co.....	16
Ralston Car Co.....	24
Revere Rubber Co.....	3d Cover
Rogers, H. A., Co.....	27
Rogers Locomotive Works.....	9
Rue Mfg. Co.....	4
Safety Car Heating & Lighting Co.....	22
Saunders, D., Sons.....	23
Secor Typewriter Co.....	—
Sellers, Wm., & Co., Inc.....	23
Sipe, Jas. B., & Co.....	18
Smooth-On Mfg. Co.....	19
Standard Car Truck Co.....	2d Cover
Standard Coupler Co.....	14
Standard Paint Co.....	337
Standard Steel Works.....	8
St. Louis Car Co.....	18
Star Brass Mfg. Co.....	—
Starrett Co., L. S.....	23
Storrs Mica Co.....	347
Symington, T. H., & Co.....	22
Tabor Mfg. Co.....	7
The Tanite Co.....	345
Underwood, H. B., & Co.....	11
Union Switch & Signal Co.....	345
United States Metallic Packing Co.....	25
Vanduzen Co.....	27
Vulcan Iron Works.....	9
Walker, A. Fenton.....	343
Walworth Mfg. Co.....	2d Cover
Washburn Co.....	4th Cover
Watson-Stillman Co.....	4th Cover
Westinghouse Air Brake Co.....	12
Westinghouse Electric & Mfg. Co.....	11
Whittlesey, Geo. P.....	337
Wiley, John, & Son.....	344
Wood, R. D., & Co.....	16
Zephon Chemical Compound Co.....	19
Zeller, Geo. A.....	16



# Railway and Locomotive Engineering

Copyright by Angus Sinclair Co.—1907

A Practical Journal of Railway Motive Power and Rolling Stock

Vol. XX.

136 Liberty Street, New York, August, 1907

No. 8

## Early Wooden Bridges.

The wooden trestle, as well as the wooden bridge, may fairly be called "na-

inventor. Burr and Wernwag, two Pennsylvania carpenters, were very successful in building a form of wooden bridge

upper chords, with posts and braces between. The posts were framed into the chords and the diagonal braces, which



HOWE TRUSS RAILWAY BRIDGE AND LIGHT CARRIAGE ROAD BRIDGE CROSSING A DEEP MOUNTAIN GORGE.

tives" of the United States. One of the earliest forms of wooden truss bridges was known as the Burr bridge, after its

which combined the principle of the arch and that of the truss.

This structure consisted of lower and

were made of wood, were framed into the upright posts. A pair of wooden arches were placed one on each side of

the trusses, and these arches rested upon the abutments below the lower chord, and extended very nearly up to the top chord of the bridge. A bridge of this description was built by Wernwag in 1803 over the Delaware River, and was used as a

members being made of one of these materials and some of the other. In the Howe truss the wooden posts used in Burr bridges were replaced by iron rods, and the diagonal members crossed each other in the form of the letter X, and

Very many railway bridges were built in this country on the Howe truss plan with spans of 200 ft. or more. One of these was the bridge on the Philadelphia, Baltimore & Wilmington Railroad, which spanned the Susquehanna River at Havre de Grace. This bridge was completed in 1850, and had a total length of about 3,500 ft., there being thirteen spans of 250 ft. each, and a swing span of 176 ft. The work of building this bridge occupied five years, and it cost about \$2,000,000. Howe truss bridges have now been almost entirely replaced by iron structures; they are to some extent used for highway bridges in localities where timber is cheap. Iron bridges are for the most part cheaper, and the metal structures have longer life under natural wear and are generally more satisfactory than wood or wood and iron in combination.

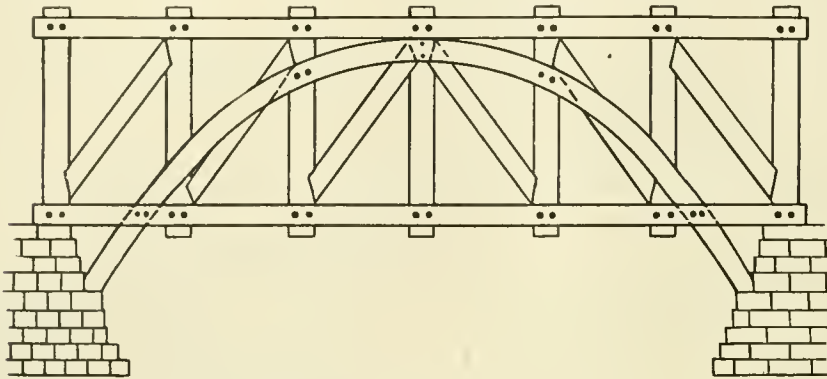

OLD BURR BRIDGE WITH WOODEN ARCH.

highway bridge for forty-five years. It was subsequently strengthened and used as a railway bridge for twenty-seven years, until finally superceded by an iron structure.

Burr and Wernwag were very particular about the quality of the material used in their bridges, and never put unseasoned timber into their work; in fact, no piece of timber was used by them unless it was at least two years old. The reason for this is not far to seek. The absence of adjustable braces was a defect inherent in the design, and timber which would likely shrink in any way was naturally very undesirable.

The combination of the arch and the truss was not successful. In long spans it was found that the arch practically carried the load and the truss acted more as a stiffener to the arch than as a load carrier. The difficulties experienced with the Burr truss and arch bridge were more or less aggravated when applied to railroads, as the concentrated moving loads tended to produce more intense vibrations and undulations, and these loosened even the well seasoned timbers of which the structures were composed.

In order to obviate the results of the defects which existed in the Burr truss, several forms of bridges were devised in which the arched part of the structure was entirely abandoned. A truss devised by Stephen Long was practically a lattice girder, in which the diagonal braces abutted upon wedge-shaped pieces of wood which were let into the top and bottom chords to the depth of one inch. The chords were bolted together at intervals, one through each of the wedge-shaped pieces. Each diagonal brace passed through two panels.

Following this development, the truss invented by William Howe made its appearance in 1840. It was a modification of Long's truss, and was, in fact, a combination of wood and iron, some of the

formed each one panel. In this truss the braces butt at each end against cast iron angle blocks, and the vertical ties had nuts at each end; that is, one on top of the upper chord and one on the underside of the lower chord.

This arrangement had some distinct advantages, as by tightening upon the nuts any desired degree of camber could be given to the whole structure. The centre of the truss could be brought up to a slightly higher level than that at the abutments. The tightening of the tie rods also allowed of better adjustment of the truss than had previously been attained in Long's bridge.

The Howe truss became very popular on account of facility of construction and its satisfactory action under the passing of heavy loads. It was extensively built for highway and railway service. In fact, it was the typical form of almost all railway bridges from 1840 until about 1870. For railroad bridges greater in span than

#### Rail Motor Cars.

The report of the committee of the Master Mechanics' Association, on Rail Motors, which was presented at the recent convention, showed that the most work in this country has been done on the Union Pacific Railroad, which company have built nine gasoline motor cars, each of which has a direct mechanical drive. Their latest design of car is equipped with a 200-h.p. motor, intended for service on suburban lines. This car has been running since last summer. The car has shown uniform results, which have been very satisfactory. Ten similar cars are being built, as well as a number of trailers. It was stated that after two years of service the average cost of fuel with 72 degs. gasoline is 3½ cents per car mile. Another type of motor car in successful operation between Kansas City and Olathe last year, was the Strang car, three of

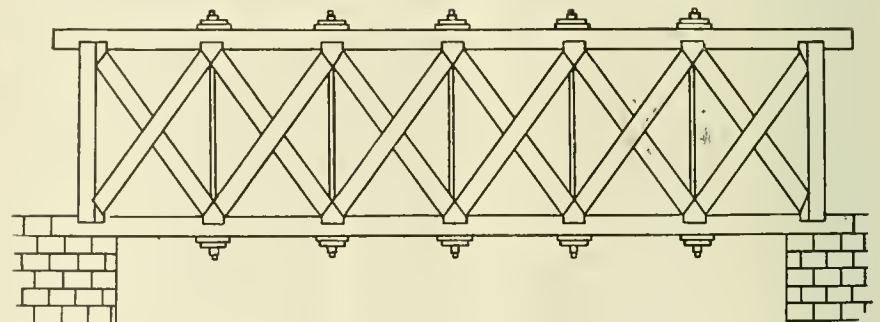

SKELETON OF THE HOWE TRUSS BRIDGE.

about 140 ft. the Howe trusses were generally stiffened with arches, after the manner of the original Burr bridges. The comparative cheapness of the Howe truss was also a strong point in its favor, but the fact that wood was used very largely in its construction necessarily introduced fire risks, and the liability to decay and deterioration could never be entirely eliminated.

which have been used. Several other cars were described in the report.

In the steam motor field, the report referred to the car built by the Canadian Pacific Railway which was in operation last summer between Montreal and Vaudreuil, a distance of 24 miles, giving a service of three round trips per day. The fuel is oil although coal has been successfully used.

# Patent Office Department

**GAUGE-COCK.**

Mr. W. H. Kriner, Hagerstown, Md., has patented a gauge-cock, No. 857,634. It comprises a screw-threaded end having a central steam passage, a body portion with an enlarged valve

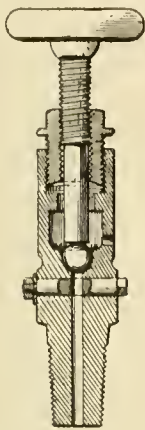

IMPROVED GAUGE-COCK.

chamber, a valve seat at the upper end of the central steam passage, and an outlet or port near the bottom of the enlarged chamber. There is a spherical shaped valve adapted to play loosely in the valve chamber, and is held securely on its seat by the lower end of the valve stem when the stem is turned down upon it.

**WATER PURIFIER.**

Mr. J. C. Stewart, Marengo, Ill., has patented a mechanical water purifier for locomotive service. As will be seen in the accompanying illustration, a receptacle is placed adjacent to the boiler, admitting hot water under pressure slightly greater than the

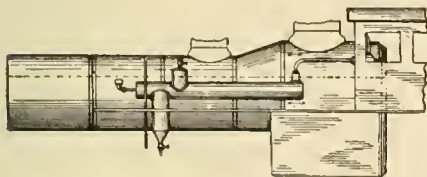

FEED WATER PURIFIER.

pressure carried in the boiler. A well is constructed near one end of the receptacle, into which all matter heavier than water is deposited. A deflector sheet aids in the separation of heavy particles. There is also a dome attached to the receptacle in which are collected such substances as are of less specific gravity than the water. Blow-

off cocks are attached to the well and dome. Pipes are arranged so that the introduction of cold water into the receptacle is accompanied by a sufficient quantity of hot water to raise the temperature so high as to cause the precipitation of the substances in the water.

**STEAM GRATE SHAKER.**

A method of shaking grates by steam power has been patented by Mr. N. H. Hughes, Birmingham, Ala., No. 845,090. The apparatus may be applied by either single or double rocking shafts which are engaged to single or double pistons in steam cylinders. Each cylinder is adapted to rock or oscillate as required to operate the lateral arms of the rocking shaft. The cylinders are

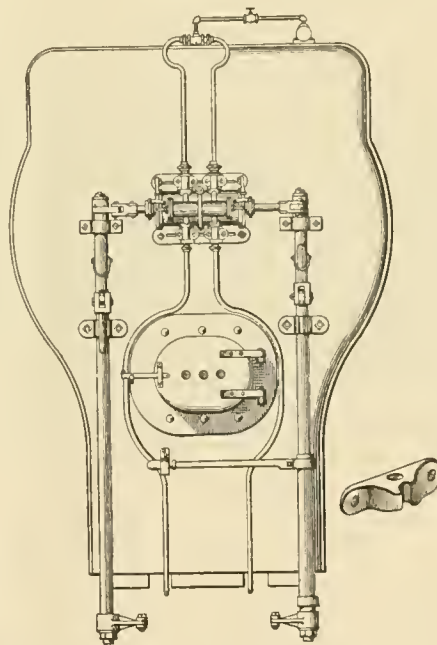

APPARATUS FOR SHAKING GRATES.

furnished with distributing valves, the valves having a rod which is pivoted to a vertical hand lever. This lever works in an arc-shaped keeper, which limits its throw in opposite directions and the movement of this lever actuates the pistons. The device has been successfully tested on the Louisville and Nashville Railroad, and its application to the larger class of locomotives has been warmly recommended.

**GREASE CUP.**

A lubricating device has been patented by Mr. J. Powell, Cincinnati, Ohio, No. 824,882. The device comprises a grease

container, a cup having a feeding vent, an adjustable cap, and an automatically operated feeding follower fitted within the cup and having an expandible packing and a fixed support adapted to project beyond the edge of the pack-

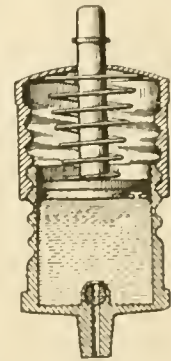

LOCOMOTIVE GREASE CUP.

ing lip to prevent the edge from being turned back in the act of inserting the follower within the cup.

**CLAMP AND LUBRICATOR.**

A combined valve stem clamp and lubricator has been patented by Mr. J. C. Williamson and Mr. W. D. Barker, Tallahassee, Fla., No. 831,814. The device serves the double purpose of lubricating the valve stem outside the stuffing box, and also permits the engineer to quickly and securely lock the valve stem, and hence the valve, against movement in case of a breakdown. The two members of the lubricator are

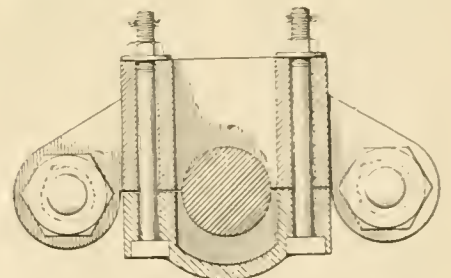

VALVE ROD CLAMP AND OILER.

connected with each other by bolts, and it is only necessary to screw up the nuts of the bolts to firmly clamp the valve stem. It can be readily attached to any existing engine, and in necessity arises there is no need of extraneous attachments, which are often out of order and of doubtful service.

Cecil Scores a Point.

By T. Toot.

"Well, Toot, I see you are getting things in pretty good shape and moving along nicely now," and so saying Mr. Chasem, the M.-M., rubbed his fat hands together with as much satisfaction as if he had raised my wages to the limit,

been taking this all in, and when Cecil had finished, he remarked: "Be jaber, Jamie, the professor is going to introduce watch making wid us. Phat the divil will he be doing next?" As Cecil's idea was an excellent one, I give it as we worked it out. Fig. 1 shows the jig plate with washers and the bolts and keys.

I had started on some improved formers for sill steps. I got a hustle on me and this was the result: Fig. 3 shows the form, Fig. 4 the arms, Fig. 5 the wedge to hold the blank in place, and Fig. 6 the roller arms on the moving head. The roller arms can be used for any form of this description, as they are adjustable on the moving head, and a 1 1/8 in. threaded bar through the eye pins gives it a close adjustment and great retaining power on the side.

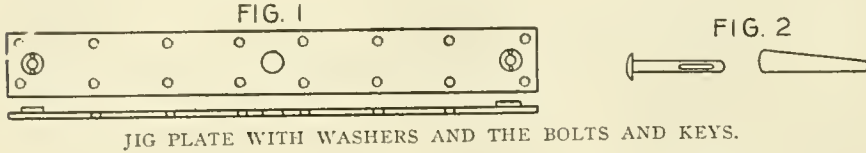

JIG PLATE WITH WASHERS AND THE BOLTS AND KEYS.

and I just had my mouth fixed for this laudable enterprise and have no doubt the M.-M. saw what was coming, so he broke in with, "Don't stand still, Toot. Keep working your noodle improvements, Toot! Improvements are what count, and we can stand all you can give us. Make use of Cecil. He has lots of good things stored up in that fine-haired cranium of his, for he has worked in some mighty good places, and no doubt he would be holding a good position now, only everybody would have to have a dictionary to keep track of that high-powered, gilt-edged language of his. The scamp does take with the ladies, though." The M.-M. edged up to me and lowered his voice to a confidential tone, and the lines around his mouth relaxed to a faint smile.

Con rivetted on the bolt holes for a wearing surface. Fig. 2, the bolts with keys; such jigs can be made for several different kinds of work, which must be accurate.

Things had been pretty quiet in the shop for awhile, but as St. Patrick's Day was near, I knew the boys would have a time, so this is what came of it. As we had several jobs that had to be finished on that day, I had Cecil work and let Con off in the morning, with his promise that he would work in the afternoon. It seemed rather strange to me, too, as he agreed very willingly to come back, and the subsequent events showed the cause.

I was just about to speak when the M.-M. came back to the realities of every-day life with, "Yes, Toot, I know what you were going to say about the shop. Keep them on the move, and anything that you know is needed, make it, or I will get it for you."

Con motioned for me to come over to him, and with a mysterious air, said: "Be jaber, boss, do yez know phat the professor be doing now?" And on my shaking my head, he leaned over the anvil and whispered: "Sure the widdy has bought her an atti-mobile, and he's learnin' to run the divil's wagon, for I seen him out in it last night and I

It seems that Cecil had squared himself with the widow, and she had made a date to come to the shop in her new auto and take Cecil home; but in the

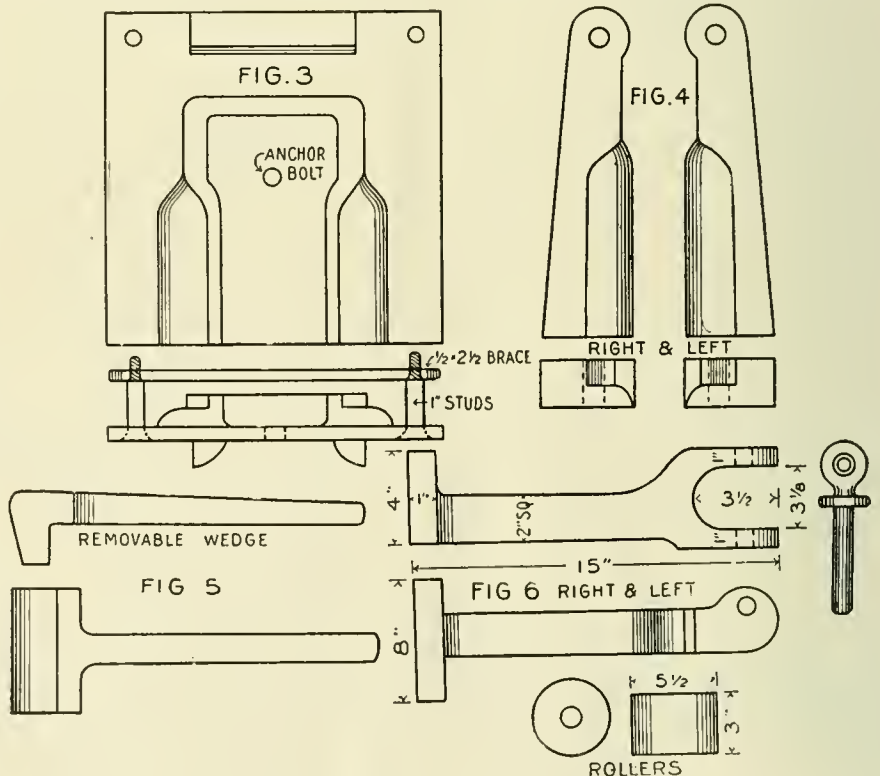

SOME OF TOOT'S BLACKSMITH SHOP KINKS.

Well, everything comes to the man who hustles while he waits. I proceeded to the hustling. We had some difficulty about holes matching in our truck, and body bolsters, so I proceeded to interview Cecil on the subject and meandered over to his forge. "Ah, Mr. Toot!" said he. "I was schooled in the art of horology, and the mathematical correctness of establishments producing fine watch work is only accomplished by a due consideration for exact measurements in the form of jigs, properly secured to the article under operation. My suggestion would be to dispense with the wooden patterns now used here, except two-end holes, make a thin sheet-iron pattern with all holes mathematically correct, secure this to the blank bolster plate by two key-bolts and proceed to punch through pattern and plate, and you will find the product of this method as satisfactory as drilling and punching holes through a jig in a watch plate, which is the means those fine mechanics adopt for correct work."

Our Hibernian neighbor, Con, had thought it was the ould man's (the M.-M.) until my Danny, that works at the freight house, told me the widdy had got one like the ould man's. Sure the b'ys should have them in Patrick's Day parade, for they're green all over." This seemed to set Con thinking, for he grinned and did not say any more, and his reference to St. Patrick's Day made me think it was coming around.

meantime the auto had, under her guidance that day, run into a barb wire fence, and in consequence of that sad event, limped back on two flat tires. So it was out of commission. But it happened that Mr. Chasem's auto was in good killing trim (or traveling trim, if you like that expression better). The widow accepted a warm invitation from him, and as he

had some business at the office, he motored down there just about quitting time and left the widow and the auto in front of the shop just as we were leaving work.

Con was just ahead of me, and when he saw the auto and the widow seated therein he grabbed me. "Hould your whist, Mr. Toot, and watch the professor. Sure it'll warm the cockles of your heart for many a day." He no sooner had the words out of his mouth than out of the shop pops Cecil with a bright green band around his immaculate plug hat, a shamrock pinned to the lapel of his Prince Albert, and his shoes of the same vivid color. Of course the boys set up a roar when they caught sight of him, but not minding them, he raised his tile to the widow, took a flying leap for the auto and was off like a shot just as Mr. Chasem, the M.-M., came out of the office door. Well, I don't know what explanation Cecil made, and I don't know what explanation the widow

#### Prairie for the Soo Line.

The Minneapolis, St. Paul & Sault Ste. Marie Railway, more commonly called the Soo Line, have recently added ten compound engines to their motive power equipment. These engines are of the 2-6-2 type, and are cross-compounds, with cylinders  $22\frac{1}{2}$  and  $35 \times 26$  ins. With 63 in. drivers and a steam pressure of 200 lbs., the tractive effort of the engine is about 26,750 lbs., and with a weight of 133,000 lbs. on the drivers the factor of adhesion is 5.

These engines are intended for mixed service, and were built at the Schenectady Works of the American Locomotive Company. The cross-compound engine has for a great many years been a favorite on the Soo Line, and has proved very successful in both freight and passenger service on that road. These engines, however, are the first of the prairie type to be built for the M., St. P. & S. Ste. M. Up to the

zation, a departure has been made from the ordinary practice by equalizing the front and main driving wheels with the front truck and the rear drivers with the trailing truck, instead of equalizing the two rear drivers and the trailing truck together, as is usual in this type.

All the wheels are flanged, the rear driving wheels are the main ones and on their axle the eccentrics are carried. All the rods are of I-section, and the low pressure cylinder is placed on the right side. The wheel base of the engine is 29 ft. 3 ins., the driving wheel base being 11 ft. 4 ins., and with the tender the total wheel base of both together is 56 ft.  $6\frac{1}{2}$  ins.

The travel of both piston and slide valve is 6 ins. The lap on the high pressure valve is  $1\frac{1}{4}$  ins. and 1 in. on the low pressure. The exhaust clearance is  $\frac{1}{4}$  of an inch. Both valves are set line and line in the forward motion, and  $\frac{1}{4}$  in. lead at one-half cut-off on the low pressure side.

The boiler is of the extended wagon

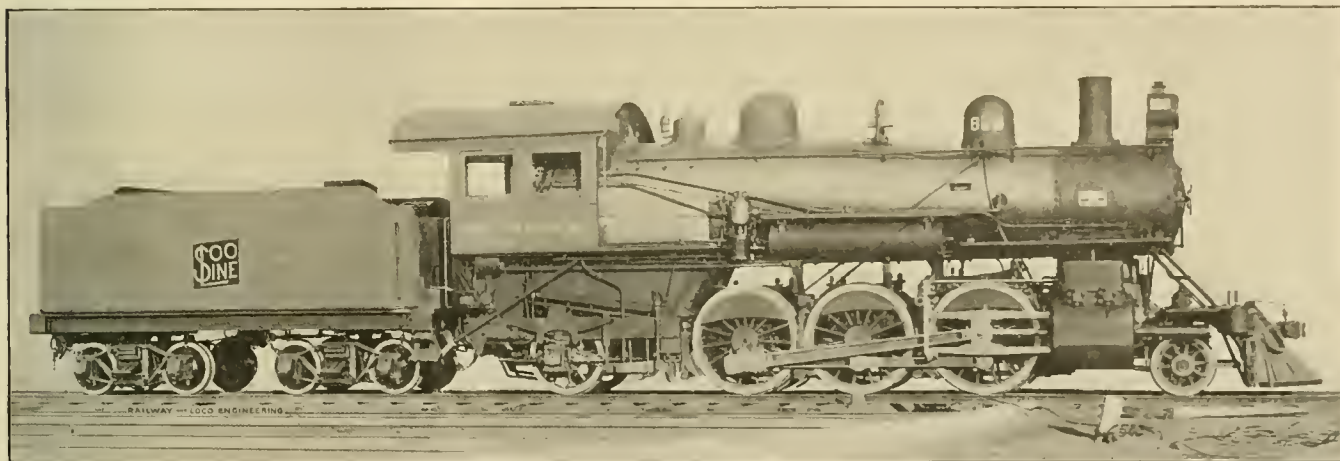

SIMPLE, PRAIRIE TYPE ENGINE FOR THE SOO LINE.

T. A. Foque, Mechanical Superintendent.

American Loco. Works, Builders.

made, but I do know what the M.-M. said standing on the office steps and watching Cecil and the widow disappearing in a cloud of dust and the boys falling all over each other in the exuberance of their merriment at the comical situation. What the M.-M. said would, I fear, be totally unfit for publication.

"Be jabers, Mr. Toot," says Con, "we got it on the professor, and the professor turned it on the old man in foine stoile; but begorra I believe the widdy has the best of it all around, so I do."

The desire for industrial education is so keen among the natives of Egypt under the progressive policy introduced by Lord Cromer that he was constantly importuned by respectable parents to permit their sons to be admitted into industrial schools established for the incarceration of criminals.

present time their fast freight service has been handled by the 2-6-0 type of engine, but as these machines will be also used in passenger service, the 2-6-2 type was selected as offering the advantage of greater boiler capacity for high speed work than could be obtained in the ordinary Mogul type.

In working order the engines have a total weight of 191,500 lbs., of which 133,000 pounds, or 69 $\frac{1}{2}$  per cent., is carried on the driving wheels. The engines are compounded on the Schenectady principle. The cylinders are so proportioned as to give a cylinder ratio of 1 to 2.42. The high pressure cylinder is equipped with a piston valve, and the low pressure with an Allen-Richardson slide valve, the valves being actuated by the ordinary shifting link motion. The frames are of cast steel, with double front rails and a separate slabbed section at the rear for the trailing trucks. In the matter of weight equali-

top type, with sloping back head and throat sheet. It is made in three courses, the outside diameter of the first and smallest ring being  $60\frac{1}{4}$  ins. The tubes, of which there are 266, are 2 ins. in diameter and 15 ft. long, which gives a heating surface of 2,077 sq. ft., the total heating surface of the boiler being 2,243 sq. ft. The firebox is 90 ins. long and  $62\frac{1}{4}$  ins. wide, giving a grate area of 39 sq. ft. The water spaces are large, being 5 ins. wide at the mud ring and increasing to 7 ins. at the crown sheet at the sides, and to 6 ins. at the back end. The ratio of grate area to heating surface is as 1 is to 57.5. The fire box heating surface is 165 sq. ft., and thus the box makes up about 7.3 per cent. of the total heating surface. The roof sheet of this boiler is level, but the crown sheet slopes slightly toward the back, giving an average steam and water space between the two of about 24 ins.

Some of the principal dimensions and ratios are as follows:

Total weight = 85.5  
 Total heating surface = 8.99  
 Volume of equivalent simple cylinders = 8.99  
 Total heating surface = 2.50  
 Volume of equivalent simple cylinders = 4.34  
 Grate area = 4.34  
 Volume of equivalent simple cylinders = 309,100 lbs.  
 Weight in Working Order—Engine and tender, 309,100 lbs.  
 Axles—Driving journals, main,  $9\frac{1}{2} \times 12$  ins., others,  $9 \times 12$  ins.; engine truck journals, diameter, 6 ins.; length, 12 ins.; trailing, 8 ins., length, 14 ins.; tender,  $5\frac{1}{2}$  ins., length, 10 ins.  
 Firebox—Type, wide; thickness of crown,  $\frac{3}{8}$  in. tube,  $\frac{1}{2}$  in. sides,  $\frac{3}{8}$  in., back,  $\frac{3}{8}$  in.  
 Crown Staying—Radial.  
 Boxes—Driving, cast steel; pump,  $2 \times 9\frac{1}{2}$  ins.; reservoir,  $2 \times 18\frac{1}{2} \times 96$  ins.  
 Engine Truck—2 wheel swing bolster C. S. frame.  
 Trailing Truck—Radial with outside journals.  
 Smoke Stack—Diameter, 18 ins.; top above rail, 14 ft.  $9\frac{3}{8}$  ins.  
 Tender Frame—10 in. steel channels.  
 Tank—Style U shape; capacity, 6,000 gals.; fuel, 10 tons.  
 Wheels—Engine truck, diam., 33 ins.; kind, Allen C. I. spke.; trailing, 46 ins., C., steel center, steel tired; tender, 33 ins.

### Railroad Crosses a Swamp.

Grading has been completed on an extension of the Southern Pacific from Lafayette to the west bank of the Mississippi, opposite Baton Rouge. Lafayette is about 145 miles west of New Orleans, and the railroad from that point forms almost a direct line to the State capital. To carry the new line across the famous Atchafalaya swamp, it has been necessary to construct twelve miles of trestle work, which is to be filled in with earth. The hardest part of the work is necessarily along this stretch of road.

When completed this extension will



RAILWAY BRIDGE AT FOURTEEN STREAMS WRECKED BY DYNAMITE.

form a short line across the State for through freight, which now moves by way of New Orleans. Although the line is only 53 miles long, by cutting out the long detour southward to New Orleans, 180 miles will be saved, resulting in a great economy, both as to cost and time on west bound shipments. Beginning at Lafayette the extension passes through the Anse La Butte oil country, and then enters the Grand Point Prairie. Sixteen miles from Lafayette the Atchafalaya swamp is encountered. Much of the swamp is overflowed part of the year, making

the trestle work necessary. The Atchafalaya River is crossed by a truss bridge 450 ft. long.

### Mono-Rail Transit.

The demand for rapid transit from the business sections of large cities to suburban or rural residences has been occupying the minds of many of our mechanical engineers, and of late the single rail system has come prominently into notice, partly from the interesting experiments of an English engineer, who claims to have demonstrated the practicability of a mono-rail system of transit whereby a car is maintained in equilibrium, the wheels coming in contact with a single rail, the even balance of the superimposed car with its load being maintained by double opposed gyroscopes, a description of which we give elsewhere in this issue. It would be imprudent to condemn anything in these days, but it must be remembered that successful experiments with light models under the most favorable conditions should not be taken as proof positive that in practical form under varying conditions the same methods would produce precisely similar results.

Mr. Howard H. Tunis, a young engineer of Baltimore, is superintending the running of trains over an experimental half-mile track at the Jamestown Exhibition, and his contrivance has been so favorably received that a company has been already formed and supported by some of the ex-members of the New York Rapid Transit Commission. The plan of the company is to build a road from New York to Newark, a distance of ten miles, and thereby give a fair practical test of what many think is the best solution of the question of suburban rapid transit for the future.

Mr. Tunis' system differs from other mono-rail systems in many particulars. In the English contrivance the cars straddle a single triangular shaped rail. In Germany there are cars running where the weight is simply suspended from an overhead single rail. The Baltimore engineer's plan consists of a single track, laid across ties similar to those used on all railways, only much shorter, being about three and a half feet in length. Two other rails are suspended overhead and are supported by steel pillars placed at intervals along the side of the road and connected by steel beams stretched across the track similar to many of the lighter steel bridge superstructures works now in use. The two rails are thirty inches apart and are L-shaped. On the top of each car, near the ends, are attached inverted trucks which are held in place by strong steel braces. These trucks are formed like the

letter X and are furnished with a wheel set horizontally at each corner of the X. The trucks are slightly flexible and the wheels rest edgewise on the L-shaped rails. This combination has the quality of steadying the car under any condition or variation of load and is the distinctive feature of



ORANGE RIVER BRIDGE, SOUTH AFRICA. BUSHES ON SIDE FACILITATE PASSAGE OF HORSES.

Mr. Tunis' invention. There is no downward weight on the overhead trucks. Whatever pressure they have is exerted sidewise and they are simply guide wheels and are constructed of cast iron, oak and leather in such a way that they make very little noise when running. Being furnished with ball bearings a high speed is possible. The cars will be of the lightest kind and driven by electric motors from overhead connections, and in largely populated districts, if the calculations of the promoters are correct, the system should be profitable.

### Exactly.

It took place in a third-class carriage coming up from Portsmouth. A young fellow had been airing his opinions on every possible subject. Finally he wound up with these weighty words, "Gentlemen, depend on it, this country is going to the dogs. What was our position a few years ago? Why, the highest among nations. But where are we now?" he demanded, in a voice calculated to strike home. "I say again, where are we now?"

A man in a corner seat who had listened to it all, quietly replied, "Clapham Junction, sir."

Then the train slowed up, and the youthful orator took his bag and went into another compartment, completely disgusted.—*London Tid-Bits.*

### Forty-Ton Well Wagon.

The new type of 40-ton well wagon put into service by the Great Northern Railway of England is here illustrated, one view being that of the wagon unloaded, and another one of the same wagon carrying one of the late Mr. Stirling's well known 8 ft. "singles," built in 1890.

The engine weighs, without water, about 44 long tons, and was put on the truck as a test load, not with the idea of carrying it about the line, because it is obviously much too high for the bridges, etc., but the well wagon was found to carry the engine quite successfully about the open yard. The two timbers shown in the view of the unloaded car are provided, for the purpose of securing large steel castings or other awkward loads and the blocks can be removed when not required. The foreman of the Erecting Shop at Doncaster is in the picture and stands near the engine step. His presence serves to give some idea of the total height of the engine as mounted on the car.

This car, which is a special one for the carriage of heavy loads of awkward size, is composed of four parallel steel girders, each made up of a box girder formed by two channels, 12 x 3½ x ½ ins., set back to back, 4 ins. apart and secured by three cover plates on top and three similar plates below. Each

cover plates, which are single, top and bottom, are 12 ins. wide. The construction of the sloping members where the sills fall from above the truck to the level of the well is very substantial, the cross section of each sill being here composed of angles and plates with heavy cross stays.

The tare of the car is 27 long tons, 7 cwt., 1 qtr., or 61,292 lbs., with angle irons on the underside to give stiffness

way of England, for the photographs from which our engravings have been made and for the data from which our information is drawn. The car was built at the Doncaster shops of the company, and forms an interesting study of design for special equipment.

### Growing Big.

The increase in the size and power of railroad equipment has recently been



GREAT NORTHERN RAILWAY 40-TON WAGON.

to the plate. The space between the outside and intermediate sills is filled with or occupied by short sticks of oak 7 x 8 ins., which rest on brackets carried on the cross ties. These pieces of oak are removable, as occasion may demand.

The level of the underhead of the lowest rivets in the box girders or sills is 8¾ ins. above the rail. The level of the top of the upper cover plate of the sills is about 1 ft. 10 ins. above the rail, and this is practically the level upon which the blocks rest which

shown by some interesting statistics just compiled by Mr. H. J. Small, general superintendent of motive power of the Southern Pacific Company. It appears that in thirty years the standard locomotive on that road has increased 175,000 lbs. That is, from 30,000 to 72,500, and now to 208,000 lbs. Tractive power has gone up from 11,600 lbs. or less, to a maximum of 43,305 lbs. for the heavy consolidation type of engine. The locomotive of to-day is 400 per cent. more powerful than that of twenty-five years ago.

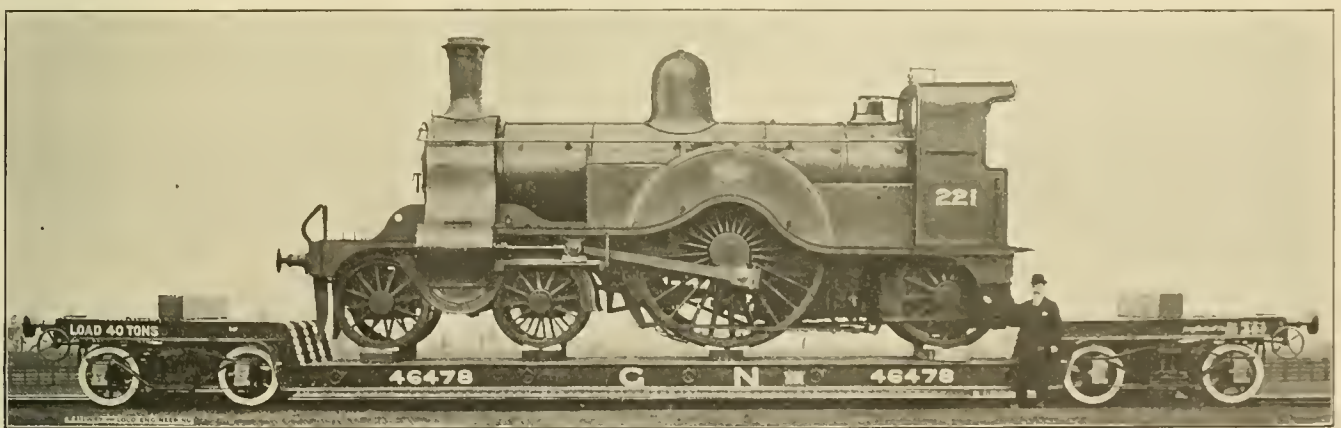

FORTY-TON WELL-WAGON, GREAT NORTHERN OF ENGLAND, CARRYING ONE OF THE 8-FT. SINGLES.

of these box girders is tied together by a pair of 10 x ¾ in. stays between the channel webs, placed about 6 ft. 4 ins. apart in the well.

The space between the two centre sills in the well is filled by removable floor plates ½ in. thick and each 6 ft. 4 ins. long. The axles have collarless journals and the wheels are 30 ins. in diameter. The car is fitted with rings along the inside of the outside sills for the purpose of binding or staying the load.

The box girders are not so deep above the trucks as they are in the well, being only 9 ins. deep, but here each of the channels is reinforced by ½-in. plate backing each web. The

carry the wheels of the engine shown in our illustration. The top of the sills over the bogies or trucks is about 3 ft. 7½ ins. from the rail, and the well is therefore about 21½ ins. lower than this level. The well is about 30 ft. long. The centres of the trucks are 40 ft. 6 ins. apart, and the car, measured over the headstocks, is 49 ft. 9 ins. The trucks are of the ordinary arch bar type. The capacity of the car is 89,600 lbs. The draw gear is passed through the headstock and is attached to the body bolster, which is of the built up box girder type. We are indebted to Mr. H. A. Ivatt, locomotive engineer of the Great Northern Rail-

The weight of freight cars has increased from 22,000 to 42,000 lbs.; their maximum capacity is now 100,000 lbs. compared with 30,000-lb. cars a few years ago. In length the freight car has grown from 27 ft. to about 40 ft.

In 25 years coaches have been widened 2 ft. and lengthened over 26 ft. The seating capacity of coaches has been increased from 32 to 70, and the height of coaches on the Harriman lines has grown from 10 ft. 9 in. to 14 ft. 2 in. The increase in car capacity on the Southern Pacific and other lines means that their carrying efficiency has been enlarged much more than the actual number of new cars indicates.

### Siamese and Westphalians.

Our illustrations show two standard gauge engines built by the Hanover Locomotive Works at Linden, in Germany. Fig. 1 is a freight engine for burning wood with six driving wheels. The engine is of the Mogul or 2-6-0 type and was bought by the Siamese State Railways. Neglecting the smaller decimals in the dimensions of these engines we

mals) are about 20.4 x 23.6 ins. The driving wheels about 51 ins. in diameter. The total wheel base measures about 18 ft. 4½ ins. The steam pressure is 175 lbs. The grate area is 21.8 sq. ft. The total heating surface is 1,363½ sq. ft., and as the engine has no truck or carrying wheels the total weight, all of which is on the drivers, amounts to about 140,000 lbs. The ten-

and got some other kind of employment.

One day a friend caught sight of him putting some terra cotta brick in place on a floor high up in one of those new tall buildings which architects use as a means of beautifying New York. The friend shouted up from the street level, "Helloa, there. Helloa, Markham, who are you working for now?" "Same people," yelled back Markham, from amid the steel beams and columns of the lofty "cloud-scraper." "Been working for 'em right along—wife and three children!"

### Varnish-Making in China and Japan.

The production and manipulation of lacquers and varnishes in China and Japan is shrouded in mystery and is always kept a profound secret; but from all we can learn they may be classed as "natural varnishes," and only require the peculiar climatic conditions for their application, their methods are not likely to be introduced into Europe or this country, because of the want of the natural material, which, when imported, becomes extremely costly, and because the process is indirect and tedious, and, with the high price of labor, would be impracticable.

We trace the use of varnish back 2,467 years, and the origin of its name 2,150 years. But in parenthesis the writer would say that the earnest student is learning much of its mysteries to-day.

The introduction of varnish-making in more than one hundred years. A story is told that William Tilden saw a German

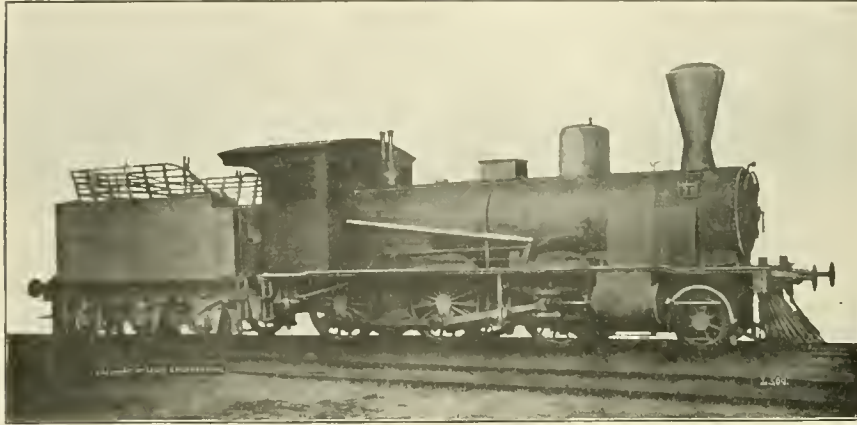

FIG. 1.—WOOD-BURNING FREIGHT ENGINE, SIAMESE STATE RAILWAY.

may say the Siamese wood burner has cylinders about 16.7 x 24.8 ins. with 55 in. drivers. The rigid wheel base is 7 ft. 2¾ ins. with a total wheel base of 20 ft. 5½ ins. The steam pressure is about 175 lbs. The total heating surface is about 1,288½ sq. ft. The grate area is about 20½ sq. ft. and the adhesive weight is about 72,600 lbs., while that of the whole machine is about 83,600 lbs. The tender holds about 2,200 gals. and about 4 tons of fuel.

Fig. 2 is a freight engine, several of which have been built for the Westphalia Railway. Mr. William M. Kellard, who is connected with the locomotive works, in writing to us about this road and engine says: "On the lines of this company there are sharp curves as well as considerable differences in the level, amongst which is one long gradient of 1 in 50. For hauling heavy trains under such conditions, the engine had to be of strong construction and of special design. In order to utilize the full weight in working order, all the ten wheels of the locomotive had to be coupled, the first and the last axle having side play. With a view to facilitate the passing of curves, the spring of the draw gear is placed further than usual inside the frame, its distance being at the front about 200 cm. (about 78¾ ins.) from the buffer board and at the back about 160 cm. (about 63 ins.) from the draw-box. When passing a curve the draw-hook and the draw-rod swing laterally on the centres of motion. The boiler of the locomotive is placed in an elevated position and the large cab is provided with gas lamps and with an air ventilator."

The cylinders (neglecting small deci-

der carries about 2¾ tons of fuel and about 1,300 gallons of water.

### Good Idea.

Markham had the reputation of being a shifter, at least his friends thought he did not stay very long in any situation. This may have been true enough, and Markham did not

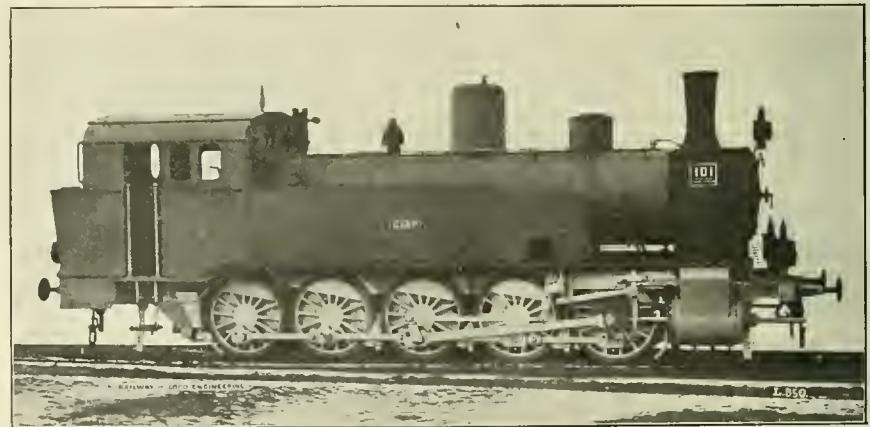

FIG. 2.—FREIGHT TANK ENGINE FOR THE WESTPHALIA RAILWAY.

deny it, but he never seemed to be out of a job for long. He was known to have worked in at least three departments of the Long Trestle & High Bridge Railway, and he had had many and fleeting business experiences. He had faithfully served one firm in several capacities, and had in the end been peremptorily turned out to make a place for a favored relative of the boss. None of these things discouraged Markham, he just went on

with a large tray on his head filled with toys, was attracted not only by the bright colors, but also by the high lustre, so stopped the man and asked him how he obtained the bright finish, and, the story goes, that he hired him to make varnish for him at 115 Norfolk street, New York, and that was the foundation of what became the great firm of William Tilden & Nephew. William Tilden is reputed to have died worth three million dollars, a great fortune for those days.



# General Correspondence

## Grinding Cylinder Covers.

Editor:

On the railway system with which the writer is connected the practice in force is to grind the faces of the cylinder covers to the cylinders when engines are shopped for general repairs. This operation is necessarily of such a nature that it entails a great deal of hard work on the men doing it, on account of the grinding being done with the faces in a vertical position and the heavy weight of the cover.

To improve on these conditions, the machine shown in the photograph was designed and put in operation in the Angus shops of the Canadian Pacific Railway, with results that fully came up to expectations. It enables one man to do the work without discomfort, and it has also served to cut the cost of grinding down to one-half of what it was under the old method. As it was entirely an experiment, no unnecessary expense was allowed, and most of the parts have been picked out from a lot of old material lying around the shop. The result was that the machine was both quickly and cheaply made up.

An old portable vertical engine mounted on a truck, a pinion keyed on the engine shaft meshes with a gear on a second shaft; on the other end of the shaft an old lathe face-plate has been secured. This serves as a crank disc, and through a small connecting bar between this disc and a wooden bar on the cylinder cover, the reciprocating motion is imparted. In order to press the cover firmly to its seat a bolt passes through the cylinder with a strap and spring on the end, which can be adjusted by a nut to give the pressure required. Sufficient room has been left on the truck for the tools used, which includes a small chain hoist, used for lifting the covers. The whole outfit can thus be wheeled to any engine in the shop, connected up to the air line, and is then ready for work.

LACEY R. JOHNSON,  
Asst. Supt. of Motive Power.

Montreal, Canada.

## Efficiency of Old Tools.

Editor:

Since the introduction of high speed steels, and modern machinery, in the main shops of our great railroad systems, it is quite a problem for the heads of departments of outside shops how to cope with the situation and to increase the efficiency of the old tools which they

have at their command, thereby increasing the output of the shops.

For the benefit of the readers of your valuable journal who have this problem before them, and who are compelled to do the best they can with old tools, I will tell you how we increased the efficiency of an old Whitney wheel lathe.

This lathe has 84-in. face plates, and was driven with a 5-in. belt, on two five step cones; but, notwithstanding the large size of the face plates, it was impossible to turn a pair of 68-in. tires without removing them from the wheel centres and clamping them to the face plates, and not then with any satisfaction, as the tool

reduced the length of the centres, and their bearings, thus bringing the face plates closer together and thereby increasing the rigidity of the work. These changes increased the output of the lathe for wheels and tires from 56 ins. down, but still further changes were necessary to enable us to get in our 68-in. tires. In order to do this we increased the width of the opening in the tool post carriage (these carriages reach from one side of the bed to the other) about one inch, which, after removing the cross feed screw, allows the tire to set in, and the tool post and tool are brought right close to the work, where they can do

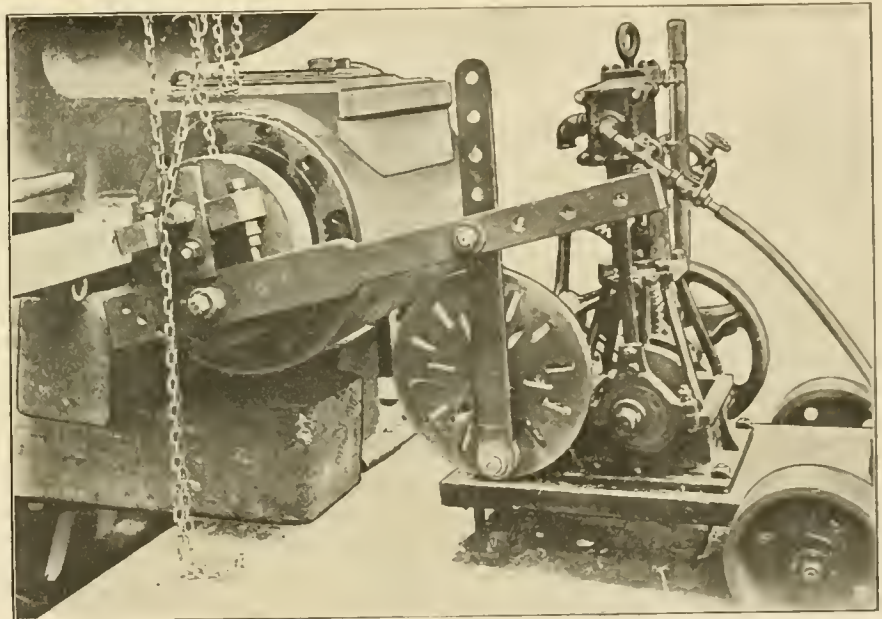

LABOR-SAVING METHOD OF GRINDING CYLINDER COVERS.

post could not be brought in line with the work, hence a long overhang of the tool was necessary to reach the cut. This, in connection with the slender tool post, prevented heavy cuts being taken, and a waste of high speed steel, for the steel could not begin to do what is expected of it. If either a large cut or a coarse feed were attempted the tool would be sure to dig in, throwing the tire out of true, causing the operator to have to reset it, which again was a loss of time.

We were determined, however, to do better with this lathe, so we took the two 5-step cones and made them, by means of bands, into two 2-step cones suitable for a 10-in. belt, so that now it will pull anything the lathe will stand; whereas, before it would pull scarcely anything worth speak of. We also re-

duced the length of the centres, and their bearings, thus bringing the face plates closer together and thereby increasing the rigidity of the work. These changes increased the output of the lathe for wheels and tires from 56 ins. down, but still further changes were necessary to enable us to get in our 68-in. tires. In order to do this we increased the width of the opening in the tool post carriage (these carriages reach from one side of the bed to the other) about one inch, which, after removing the cross feed screw, allows the tire to set in, and the tool post and tool are brought right close to the work, where they can do

business. Heavy cuts and feeds can be taken, and the efficiency of the lathe has been increased fully 75 per cent. High speed steel can be used to advantage, and we are getting satisfaction out of an otherwise useless tool. In addition to turning all our 68-in. tires in this lathe, we turn all our steel tired truck wheels, thus saving the time of changing another lathe, which, in our case, is a considerable item.

WM. HALL,

General Foreman, Chicago & North-Western Railway.  
Escanaba, Mich.

## Steam Leakage and Fuel.

Editor:

The influence of steam leaks about a locomotive on the question of fuel economy cannot be overestimated, when account is taken of the numerous

sources of such loss. The most important of such leaks is due to want of proper maintenance of slide and piston valves, the true condition of which is not understood in the earlier stages of

possibilities to have a close approximation to that condition by the use of the best valves of their kind and proper care in maintenance. C. L. B. Cincinnati, Ohio.

#### Work on Air Pump Pistons.

Editor:

Enclosed you will find photos of some lathe attachments which I have got up for turning out air pump pistons rapidly and accurately. Fig. 1 is an oil pump and oil tube drill for drilling the rods. The pump is attached to the headstock, as shown at A Fig. 1, by two cap screws, and is driven by an eccentric on the spindle nose. The chuck screws up against the eccentric. Fig. 2 gives a clearer view of the rigging. The oil is contained in tank B, which fits between the lathe shears, and is fed to the drill through hose C, and the supply is regulated by cock D, the surplus escaping back to the tank through safety valve E. The valves are contained in cages F, F.

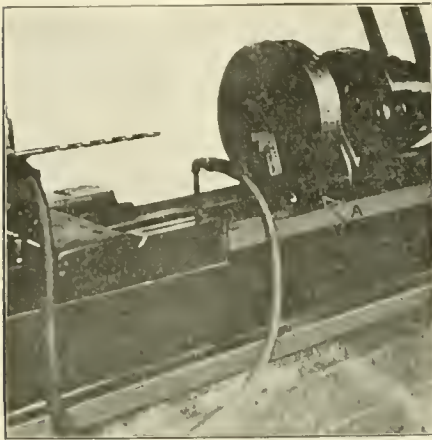

FIG. 1. OIL PUMP AND TUBE DRILL.

leakage, even though the tell-tale blow may be present, as a warning that attention is needed. The actual condition can only be determined by test.

Leakage of steam past the balance strips or the valve face of the slide valve, and also past the rings of the piston valve takes place in considerable quantities without giving evidence of loss—and such loss should not be tolerated when it has such a far-reaching effect as it has on fuel bills. The loss of steam through valve leakage is quite incredible without test to determine it. Such tests on a prominent road have shown that piston valves with old rings and bushings in so-called good condition developed a leakage of 370 pounds of steam per hour. Such a loss is something to avoid and tells volumes for want of maintenance, when the average evaporation is seven pounds of water, and oftener less, per pound of coal.

Taking as a basis of calculation, the former value, the loss of the piston valve engine due to leakage was:  $370 \div 7 = 52.5$  pounds of coal, or say 50 pounds per hour. In a ten hour run this loss equals 500 pounds, or one-half ton of coal per round trip.

This is a figure well within the facts and represents a serious loss, but if the average leakage of the slide valve engine which was 1,384 pounds of steam per hour, and also tested at the time, is taken as a basis, we have:  $1,384 \div 7 = 198$  pounds of coal per hour. This amount of coal wasted becomes 1,980 pounds per ten hour trip, and for a round trip nearly two tons of coal, due to want of improved working conditions of the valves. While it is understood that absolute tightness is impossible to be had between the nearing surfaces of a valve of any type, it is quite within the range of mechanical

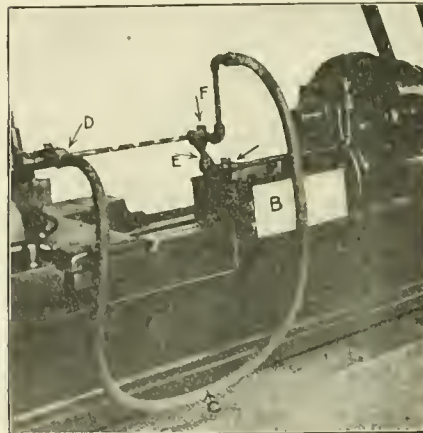

FIG. 2. OIL PUMP RIGGING.

In operation one end of the rod is held in the chuck and the other in the steady rest. The chips and oil fall into the tank, and the oil is strained and pumped over and over. With this rigging the rods can be drilled in one-third the time taken to drill with an ordinary drill. It is also very compact and does not interfere with the operation of the lathe.

In Fig. 3 A is a gang tool block for turning and grooving piston heads. It is planed on the bottom to fit the cross slide, and on top at an angle to give the proper clearance to the tools, and is held to the cross slide by two countersunk filleted head screws. The tools are held by a slotted slate and four cap screws. The block carries a turning tool, a double roughing, a double finishing grooving tool, and a double chamfering tool. B shows the grooving tools. They are made from ordinary carbon steel. The finishing tool, having only a light scraping cut to take, will last for a long time. C is an equalizing dog which in-

duces true work and prevents chattering under a heavy cut. It is held to the face plate by two pins, which it divides the strain between. D is the mandrel for the steam heads. It consists of a threaded mandrel with a bushing fitting over it, with a taper pin fitting through both. The head is screwed on against the bushing and finished. The pin is then driven out and the head screws off easily. E is the Illinois Central standard air head. It has a boss one inch high cast on it, and is reamed taper one inch per foot. These heads never work loose.

In Fig. 4, A is a turret tool block which I use to bore and face heads. It holds three turning and one boring tool. B is a three-roll roller for piston rods. It is very solid and makes a fine finish. Fig. 5 shows two boring bars. The larger one is hollow and has a rod running through it which holds the tools in a slot in the end of the bar. The clamp is split and is clamped, bar and all, to cross slide by two  $\frac{5}{8}$ -in. studs.

This is used principally for boring packing ring castings. The smaller boring bar clamp has two eye bolts which hold the bar in a V. Different sized bars may be used in this clamp. The packing ring castings have a three-arm brace cast on them to chuck them by, which insures true rings. Fig. 6 shows an air motor for grinding centers after they are hardened. It runs at a high speed and makes a nice job. I hope these kinks will be of interest to your readers.

E. L. BOWEN.

McComb City, Miss.

#### Laws of Motion.

Editor:

The three laws of motion as enunciated by Newton form the foundation of all calculations that deal with the

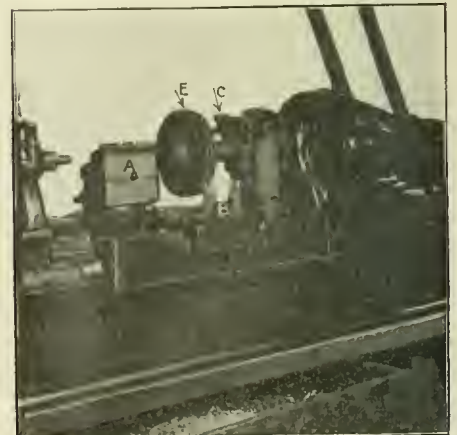

FIG. 3. GANG TOOL FOR PISTON HEADS.

effects of force upon matter. These laws, coming as they did from a master mind, while plain and simple, easily understood even by a schoolboy, are yet so important that the proper assimilation of what they express would be

of benefit to many who feel that they are masters in their chosen callings.

Newton's first law of motion states that every body will remain in a state of rest or of uniform motion in a straight line, except in so far as it is

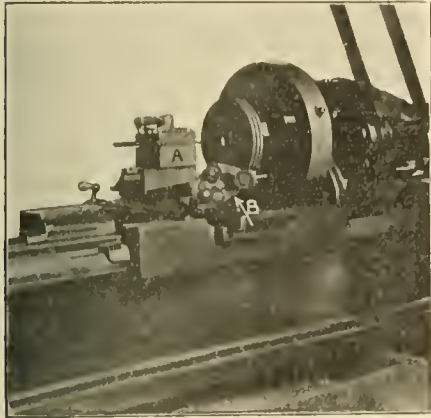

FIG. 4. TURRET TOOL BLOCK.

compelled by impressed force to change its state. The second law states that the change of state, acceleration of motion, will be in proportion to and in the direction of the impressed force. Let us consider any large mass, an immensely heavy freight train, or an ocean liner, if friction could be absolutely eliminated the force of a single breath would give motion to either of these great masses, and with friction and retarding influence removed motion would continue forever.

The motion would indeed be almost if not quite imperceptible, but it must be remembered that the giant force that moves the heavy freight, or the ocean liner, may be considered as only a multiple of the feeble forces. A feeble force acting for a length of time commensurate with its feebleness, and with no opposing force directed against it, would give to the immense mass the same velocity which the giant force imparts in a much shorter time.

It is not necessary to point out that the locomotive with one or two cars, or with no cars, can start from rest and reach its greatest limit of speed in very much less time than is required when it has to give acceleration to a heavy train, and even running light, the force exerted by the locomotive is not wholly expended in producing acceleration of its mass.

A large portion of this force is expended in overcoming the retarding effects of friction in its different forms.

In making comparative statements involving considerations of the acceleration of mass it is customary to consider the force of gravity as the actuating cause; with the mass falling vertically under the influence of this force all retarding effects, even the re-

sistance of the air, are understood to be removed.

To illustrate, if a locomotive should fall vertically from a great height, under the conditions named above, its speed would increase 32.16 ft. each second that it was falling; to reach its track speed of 65 miles per hour would require 2.964 seconds, and the space fallen through would be 141.3 ft.

In this instance the full weight of the locomotive is acting to produce acceleration of its own mass. We will suppose that but 20 per cent. of this weight is effective for that purpose (to approximate track conditions in one way, other conditions unchanged), then the time required to reach our 65 miles per hour will be 14.82 seconds, and the distance will be 706.5 ft.

Illustrating still further, we will assume that our locomotive is attached to a train, to which it has to impart velocity. We will take the weight of the locomotive at 100,000 lbs. and the

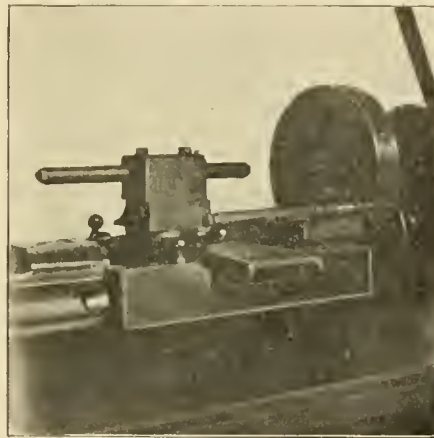

FIG. 5. TWO BORING BARS.

weight of 5 coaches at 300,000 lbs., 400,000 lbs. in the aggregate. We will take our tractive effort, or accelerating force, at one-fifth of the weight of our locomotive, tractive effort of 20,000 giving acceleration to a mass of 400,000 lbs.

This is one-twentieth of the accelerating force we had in the first instance, consequently the time required to work up our 65 miles per hour, and the space traversed, will have to be multiplied by 20. This gives 59.28 seconds as the time required and 2,826 ft. as the space traversed to attain this velocity, and this under ideal conditions with absolutely no retarding force.

If the retarding effect of journal, rail and atmospheric resistance could be accurately written as so much per ton, we could compute it and subtract this quantity from our 20,000 lbs. tractive effort to get the net force acting to give us velocity.

In the absence of exact experimental data on this matter, we will assume

50 pounds per common ton as the effort necessary to keep our train in motion at high speed, without producing acceleration. This would reduce our 20,000 lbs. to a net value of 16,000 lbs. Under these conditions, after making allowance for retardation, we have 1-25th of the weight of the train acting as a net force for accelerating its mass, and multiplying our 141.3 ft. in our first example by 25 we obtain 3,522.5 ft. as the distance and 74.1 seconds as the time required to get this amount of acceleration.

The assumption of a tractive effort of 20,000 lbs. is undoubtedly beyond the limits of locomotive performance at high speeds, but with the values taken in this article the calculations truthfully represent what we should expect.

In regard to the actual power exerted, the writer remembers reading an account of some of the indicator cards taken from the famous 999 by Mr. Angus Sinclair, proprietor of RAILWAY AND LOCOMOTIVE ENGINEERING, and the best card in that lot gave the H. P. as 1,920 and the speed as 79 miles per hour. Here we have the product and one of the factors, and dividing the foot pounds,  $1,920 \times 1,980,000$ , by  $79 \times 5,280$ , we obtain 9,114 lbs., acting through a distance of 79 miles in one hour. This was the indicated H. P., and if the amount of power that was consumed in friction in the locomotive itself was known, the remainder that was delivered at the rail could be regarded as its equivalent in draw-bar effect.

Making a further assumption on this last basis, and allowing 10 per cent for



FIG. 6. AIR MOTOR FOR GRINDING CENTRES.

power wasted in the locomotive itself, we have left in round numbers 8,100 lbs., delivered at the rail, and deducting 4,000 lbs. allowance for retardation, as in previous case, our net pull is now reduced 4,100 lbs., and multiplying 141.3 by the proper factor under the greatly reduced tractive effort we obtain 13,-

776 feet as the distance, or, roughly, 2.4 miles, and the time would be 289 seconds, or 4 minutes and 49 seconds.

As several of the best authorities claim that a distance of five or six miles must be run to build up a speed of 65 miles per hour, the pull expended in overcoming retardation must be much greater than 20 lbs. per ton at very high speeds, probably twice this amount. A recording traction dynamometer, placed between the locomotive draw-bar and the train the locomotive is hauling, will give the draw-bar pull that is exerted on the train, but it must be borne in mind that the

we could readily tell how much the locomotive drawn train is shielded from the effects of atmospheric resistance by virtue of the fact that its head end is covered.

Of course there are other expedients that might be resorted to in arriving at a value for atmospheric resistance, such as running the locomotive light under same conditions of track, speed, etc., or we might subtract the H. P. delivered to the train, figured from draw-bar pull, from the indicated H. P. of the locomotive. This would give the amount of power consumed in the locomotive for accelerating its own mass

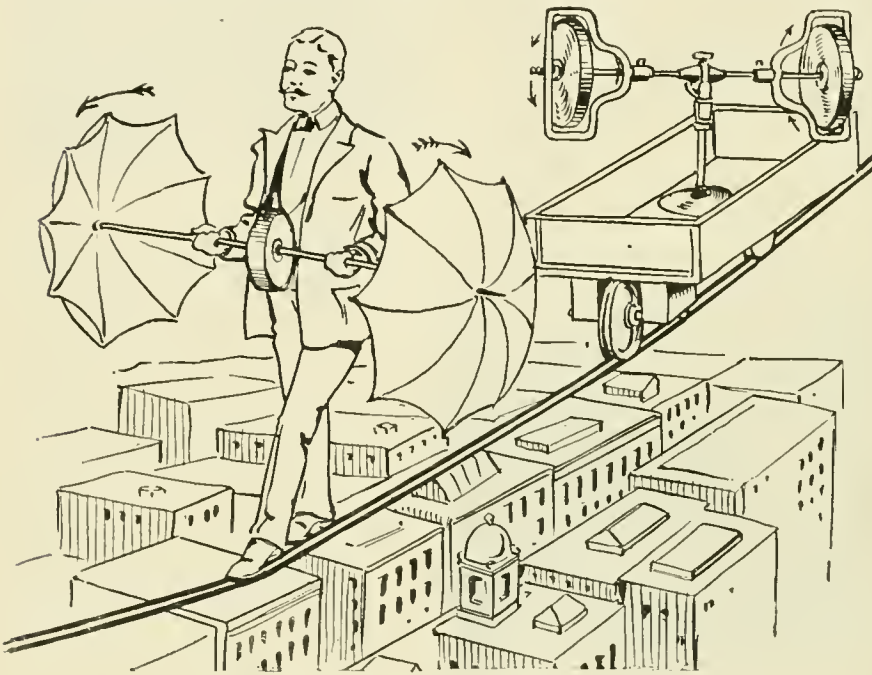

ILLUSTRATIONS OF THE PRINCIPLE OF THE GYROSTAT.

product of this force reduced to an average, and multiplied by the distance through which it acts in a given time, only represents the H. P. expended on the train, exclusive of the locomotive and tender, and this power that moves the train at this particular speed, and builds up this speed in a certain time and distance, would be inadequate to do what it really does if it were not for the fact that the locomotive shields the train from an excessive atmospheric resistance which it would encounter were it not for the fact that the train is paced by the locomotive, which gets the full benefit of air resistance. Now, with the advent of electric trains, we have an opportunity to accurately ascertain the power consumption required to overcome retardation and produce acceleration, and then by drawing this same train behind a locomotive and arriving at the power consumption by calculations based on the draw-bar pull exerted, and by comparing the power used in the one case with the power used in the other case,

and overcoming friction, retardation and air resistance, that should be charged up to the locomotive proper. After all, an accurate expression for the value of atmospheric resistance (the most important factor connected with high speed) is still lacking. The various quantities, engine friction, axle and rail friction and air resistance, are still unseparated. The subject of air resistance, and the effects of wind pressure against different surfaces, and with varying velocity, is a matter that has received much attention from scientific men during the last half century, but the deductions that have been made, and the formulas that have been devised, cannot as yet be regarded by the practical worker as anything but approximating to accuracy that, unfortunately, are many times very far from the truth.

T. H. REARDON.

*North Adams, Mass.*

A pound of good bituminous coal contains about 14,000 heat units.

### Gyrostat and Mono-Rail.

The new mono-rail system recently perfected in England by Mr. Louis Brennan, has brought out numerous references to the well known action of the gyroscope or gyrostat as the modification by Lord Kelvin is called. Talking of the gyrostat reminds us of the opening words of Prof. John Perry in the published account of his "Operatives' Lecture" at Leeds, when the British Association met there in 1890. Prof. Perry spoke of the question asked by one of the masters in a Board School a week before the meeting. It was, "Who are the members of the British Association? What do they do?" An intelligent boy promptly replied: "Please, sir, I know—they spin tops." Prof. Perry, in opening his lecture, said, "I am sorry to say that this answer was wrong. The members of the British Association and the operatives at Leeds have neglected top spinning since they were ten years of age. If more attention were paid to the intelligent examination of the behavior of tops, there would be greater advances in mechanical engineering and in many industries."

The property of becoming almost rigid, which is exhibited by limp substances when rotated rapidly was clearly exemplified in the lecture to which we have referred. A small ring of chain lay in a heap on the table. Presently it was put upon a mandrel which it just fitted, and mandrel and chain were revolved at a rapid rate. While spinning, the ring of chain was gradually pushed off the mandrel, and it rolled along the table like a solid hoop and on dropping to the floor, rebounded as if it had been a circular bar and continued to roll along the floor until, its motion at last expended, it fell in a limp heap again.

A child's toy hoop rolling along the ground, a top spinning, a moving bicycle, are all examples of fixity of the axis of rotation, if we may so call it, which is a property common to all rapidly revolving bodies. The gyrostat is perhaps the best illustration of this property. One can see in a laboratory experiment just how this form of nicely balanced mechanical top will behave. When a gyrostat is revolving if the fly-wheel end is pushed downward the gyrostat swings to the right. If it be pushed to the right it rises, if to the left it moves downward, if pushed to the left it sways down. The way Prof. Perry states the first rule about the gyrostat is "When forces act upon a spinning body tending to cause rotation about any other axis than the spinning axis, the spinning axis sets itself in better agreement with the new axis of rotation. Perfect agreement would mean perfect parallelism, the directions of rotation being the same."

For the sake of illustration and to better understand this law, let us picture the mono-rail car as a man walking on a

tight rope, and further suppose that the man carries two umbrellas, the sticks of which he holds horizontally, and that he spins the umbrellas so that each revolves in an opposite direction, but just as if they were wheels. The tight rope represents the rail, the man represents the car with its electric power, and the umbrellas are the gyrostats. The man walks along with his toes pointing in the direction he is going, and the shafts of the umbrellas are at right angles to the direction of the rope. The gyrostat offers no resistance to a motion of translation. That is to say, the car may move along the rail, just as the man walks upon the rope. It is not a case of wind pressure, as one might suppose from our using the umbrellas as an illustration. In reality the umbrellas would be too light, but they serve to show the motion. It is the maintaining the fixity of the axis of rotation which is the property of the gyrostat which is the important point.

If the man with the gyrostatic umbrellas should overbalance and begin to fall off the rope, the gyrostats would save him. If he, still keeping his feet on the rope swayed over to the right, he would practically begin to revolve about the rope. If his feet were fastened to the rope he would at least have made half a turn in such a revolution when he reached the position of head down and feet up against the rope. Long before this half revolution had been completed, and before he had gone over but a few inches, the gyrostat umbrella would catch him. It is this kind of rotation that the gyrostat objects to. It tries to keep its own axis parallel to itself, in this case, horizontal. If the man swayed over to the right one umbrella would tend to go down and the other up. The right hand umbrella, however, instead of going down would swing forward and the left, backward in their gyrostatic endeavor to bring their sticks or axes parallel to the new axis of revolution, which is the rope, about which the man swaying to one side, was beginning to revolve. This motion of the gyrostat, that is, its endeavor to bring its axes, the sticks of the umbrellas, directly over the tight rope is called precession, and Prof. Perry's second rule says, "Hurry on the precession, and the body rises in opposition to gravity. In the mono-rail car special means are provided for thus hurrying the precession of the gyroscopes and thereby causing them, after any slight tilt, to return to the horizontal plane.

Mr. Brennan's invention consists of a car with two trucks, one at each end. These trucks are pivoted so that they allow the car easily to follow curves, and also permit of some vertical movement. By this means it is claimed that the car can run on curves of less radius than the length of the vehicle itself, or on crooked rails, or on the rails laid on uneven

ground. The centre of gravity of the car, whether light or loaded, is of course above the base of support which is the one rail, and the car is thus in unstable equilibrium. To overcome the natural tendency to fall over, Mr. Brennan has

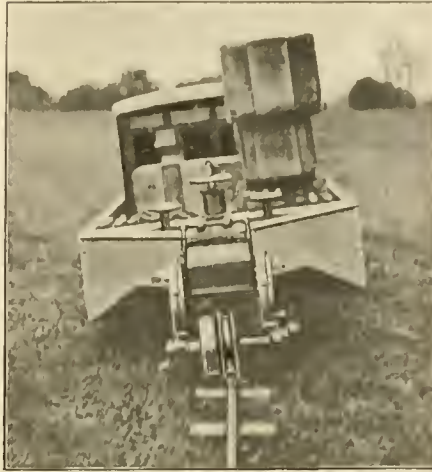

CAR CARRYING LOADED SIDE HIGH.

introduced two gyrostats, which run in a partial vacuum. They work in vertical planes and run in opposite directions; they are connected together by suitable gearing so that their peripheral velocities are equal. The gyrostats are motor-driven and run at a speed of from 7,000 to 8,000 revolutions, and the mechanism occupies little space.

In this mono-rail car advantage has been taken of the well known property of the gyrostat to resist change of direction of its own axis of rotation, and with heavy fly wheels revolving at high veloc-

veloped by the gyrostats causing the car body to adjust itself as occasion may arise.

The model was made in order to illustrate the value of the invention for military purposes. It was therefore designed for low speed, but with grade climbing capabilities. The model car was loaded with weights representing 20 tons, and a weight corresponding to that of 15 men was suddenly put upon one side of the car, and the side of the car on which this weight was thrown gradually rose so as to restore the equilibrium of the whole. It is stated that the British War Department will conduct trials with a full sized car, and if this is done we may hear further concerning this remarkable invention.

### Mechanical Stokers.

As long as the movement continues to increase the work performing capacity of locomotives, efforts will be persisted in to develop mechanical appliances that will relieve the fireman of the fearful toil necessary to supply huge locomotives with the fuel consumed in steam making. The subject has been prominently before railroad companies for the last ten years, but little of real progress has been made considering the importance of the problem.

The committee appointed to report on Mechanical Stokers at the last convention of the Master Mechanics' Association merely reported progress, which was all they could do since nothing of any importance had been brought out



SIDE VIEW OF THE BRENNAN MONO-RAIL CAR.

ities, it is very considerable. The equilibrium of the car while running is thus maintained, the variations in weight on either side of the car being equalized by the constant adjustability of the car. Mechanical devices are used to obviate the tendency to fall over by raising the heavier side of the car, the force de-

veloped by the gyrostats causing the car body to adjust itself as occasion may arise.

One peculiar item of information concerning the necessity for mechanical stokers was brought out during the discussion. Mr. J. F. Walsh, S. M. P., of the Chesapeake & Ohio Railway, has hitherto been a warm advocate of

mechanical stokers, but at the discussion referred to he remarked:

"I do not know that I can add anything to what the chairman of our committee has just read. We had a great deal of experience with the original Kincaid stoker, and outside of some of the weaknesses of its mechanical parts we had no trouble with it. It performed the service it was intended for on the class of engines it was intended for, thoroughly; that was with the narrow and long firebox, on heavy locomotives, in freight service particularly. We have but a few of that type of locomotive compared with the wide firebox locomotives. The result is that our narrow and long firebox heavy consolidation engines have been to a very great extent assigned to coal districts and to short runs. The wide firebox heavy consolidation engine has taken

#### General Foremen's Association.

##### *The Individual Effort and the Piece Work Systems.*

ADDRESS OF MR. CLYDE HASTINGS.

"While I was sitting in the rear of the room, was asked to give an explanation of just what we mean by efficiency. We have taken up the subject of efficiency and talked about it, but I am not sure whether all of you understand what we mean when we say standard efficiency, 125 or 60 per cent. You understand that we have a standard time assigned to every operation that is to be performed. This time under the Piece Work System would correspond to the piece work rate for that particular job, but in this case we have hours instead of dollars and cents.

"When a man is assigned a job, say, ten hours standard time, and if he takes

have of checking up the time, and we get that man's efficiency for the month. As you will notice, Mr. Barton in his paper shows one at 210 per cent and two between 15 and 20 per cent. In the case of raising a man's wages, we always refer to the man's efficiency, by which we are able to settle any questions that may arise."

Mr. Frank Hunt, of the Santa Fe, at Newton, Kan., said: "Under the Individual Effort System and the Piece Work System, you have the same amount to do, only along a little different lines. We find that where a workman does one class of work he becomes more efficient in the application of those tools, and we encourage it. Even should we set a price on a tool or a jig or device of our own idea, and the workman, after the price is set, should devise some tool or jig wherein he can make better time, we give that workman the benefit of that increase. We do not disturb his price, but we hold that if a tool or jig is made at our expense we should reap the benefits therefrom. We find it is the best policy to encourage the workman all we can. It stimulates the men to get up some ideas of their own. He is working on that same work day in and day out, his mind is always on that same thing, and he is better acquainted with what is best.

"In regard to the scrap pile growing big. In the shop in which I am located, I have a material man. The very best of the material that goes to the scrap pile is looked over and goes back to his storeroom and issued back to us on what we call requisitions on the storeroom, but there is no charge to us. At one time we were using as high as two kegs of  $\frac{7}{8}$ -in. nuts in one day. Now we are only using one and one-half kegs a week, and sometimes hardly that much. We simply convert everything of a serviceable condition back to the storeroom, and I think in that way it will bring down our repairs and renewals. Of course, we realize that all shop expense is classified as charged where it is unclassified for repairs and renewals. Of course, on the locomotives, we have to stand it. There is no profit and loss account.

"If we have a man that does not turn out a satisfactory job, we hold him responsible for it. We are very careful in our erecting. We put our locomotives on trial and get a report from the engineer in charge who breaks them in. We have a very careful inspection made of the engine after it is on trial, and if there is anything at fault, the party who has done defective work has to right it."

Mr. Barton concluded his remarks by saying: "The Individual Effort



PLYMOUTH LIMITED, GREAT WESTERN OF ENGLAND, HAULED BY NEW FOUR-CYLINDER COMPOUND.

the place of the long, narrow firebox engine on the long freight runs, and with the advent of the wide firebox engine we do not see the necessity for a mechanical stoker which we thought was necessary with the other type of engine, and so far as we are concerned, we do not see the necessity for a locomotive stoker on the wide firebox engine. We have no trouble going over 125 mile division with a 4,000 ton freight train, with the wide firebox engine, and one man firing, while with the long narrow firebox engine of the same size it was, in warm weather particularly, a practical impossibility to get continuous, steady travel, so that I am safe in saying that so far as we are concerned the wide firebox engine has done away with the necessity for the mechanical stoker."

Meanwhile the committee is continued.

ten hours to do that job in, his efficiency is 100 per cent. The way that is determined is by dividing the standard time by the number of hours the man actually took. If a man did ten hours standard work in eight hours, you will admit he has more than 100 per cent efficiency. We say he has 125 per cent efficiency. We divide ten hours by the eight hours actually taken, which gives you 125 per cent. If, on the other hand, he took more than ten hours to do this job, say fifteen, we divide ten by fifteen, which would give us 66 2-3 per cent efficiency. That is the way we determine a man's efficiency for any day, week or month or any period you desire. Say, we want to determine it monthly. At the end of each month we divide the number of standard hours worked by the number of hours actually worked, as shown by the clock, or whatever method you

would take advantage of all the returns to the scrap pile. He speaks of it being turned over to the storeroom. We have a man at our shops who goes direct to the scrap heap and gets material. If he needs any repairs given to it, we either report it on the engine number on which we are going to use it, or have a shop order made to cover repairs on the whole lot that he brought over, and it is turned back to the storeroom and used as serviceable material for other work.

"There was a point brought up about getting your men interested. That's all there is to it. Get your men interested, and as an inducement to arrive at this result, I think the Individual Effort System is far superior to the Piece Work System. The mere fact that a man must make his work good on his own time should, I think, induce many piece workers to quit the service if there was a loophole for them to get out or another place for them to go to. No man, after having gone through his work as he thinks faithfully, feels he ought to be compelled to make the work good on his own time if it proves defective.

"This is covered in the Individual Effort System. Certain gang costs are allowed to us for engines. If the gang cost runs up, the pay of the whole gang would naturally go down. If the time which is charged against a certain engine, and against a certain gang that has proved defective—the engine has been on trial, has broken down and is returned to the roundhouse, and the inspector's report calls for certain defective work being corrected, has to be made up, this work is charged to the gang and their gang cost goes up, but in all cases, the men have got their day rate."

(For Discussion see page 378 of this issue.)

#### More Dangerous Than Railroads.

For years back the editorial writers for all sorts of publications have found an unflinching theme for fierce articles on the daily carnage committed on railroads. Railroad companies have blotted the life out of many persons, but they have steadily introduced improved appliances and improved methods for the prevention of accidents; but now a rival has come into operation whose leaders seem to be deliberately scheming to make their appliances more deadly. This is the automobile, its operators and manufacturers.

Nearly all States have passed laws restricting automobilists to a speed of twenty miles or less upon the public highways, but the tendency of manufacturers and designers has been to put upon the market automobiles of enor-

mous power that are in reality racing machines with more than express train speed capabilities. People operating such machines are not compelled to run beyond the legal speed, but having the power under their hand is a constant temptation to indulge in reckless velocity. The result is that fatal accidents are of hourly occurrence, entailing a constantly growing death rate. The makers of automobiles who glory in the high speed capacity of their machines are really responsible for the increasing carnage. These people are inviting legislation that will prohibit the use

of its warehouse room by more than 200,000 square feet, to lay five miles of additional tracks, not including industrial tracks, in San Francisco, to lay temporary rails for the purpose of removing debris and handling material for the rebuilding of the city, and to carry nearly a quarter of a million passengers and 1,600 carloads of relief supplies free.

The Southern Pacific is now considering the electrification of its lines radiating from Oakland, and will gradually extend this work until all its suburban traffic is handled by this form



RAILROAD, HILLS AND RIVER.

upon the highways of automobiles capable of exceeding the legal speed and it is certain to come.

#### Frisco's Ferries.

Figures compiled by general officers of the Southern Pacific Company show the phenomenal character of ferry transportation on San Francisco Bay since the earthquake and fire last year. Prior to that time these ferries carried a fairly regular traffic of 1,300,000 passengers a month. When the disaster occurred, it suddenly became necessary for the company to transport an additional million passengers, or 70,000 a day more than had ever been carried before. The monthly average has since kept above the 2,000,000 mark, and only lately shows a decrease as a result of more normal conditions.

Probably no transportation company was ever before called upon without warning to almost double its carrying capacity. At the same time the Southern Pacific found it necessary to in-

crease its warehouse room by more than 200,000 square feet, to lay five miles of additional tracks, not including industrial tracks, in San Francisco, to lay temporary rails for the purpose of removing debris and handling material for the rebuilding of the city, and to carry nearly a quarter of a million passengers and 1,600 carloads of relief supplies free.

#### M. C. B. Couplers.

The Committee on M. C. B. Couplers reported at the recent meeting of the Association held at Atlantic City, that during the year they had made an examination of 5,000 broken steel couplers and 3,000 broken steel knuckles together with the knuckle locks on the more prominent types of couplers now in use. Only six of the couplers represented were M. C. B. standard. The committee referred in detail to the principal positions of, and causes for these breakages and reached the conclusion that most of the trouble was due to disregard on the part of the makers to observe M. C. B. specifications and to the failure of the railroads to have the couplers fully tested in accordance with the requirements of the M. C. B. Association.

# Railway and Locomotive Engineering

A Practical Journal of Railway Motive Power and Rolling Stock.

Published Monthly by

**ANGUS SINCLAIR CO.**

136 Liberty Street, New York.

Telephone, 984 Cortlandt.

Cable Address, "Loceng," N. Y.  
Glasgow, "Locauto,"

**Business Department:**

ANGUS SINCLAIR, President.  
JAMES KENNEDY, Vice-President.  
JAMES R. PATERSON, Sec'y and Treas.

**Editorial Department:**

ANGUS SINCLAIR, Editor.  
GEO. S. HODGINS,  
JAMES KENNEDY,  
CLARENCE RENSHAW, } Associate Editors.

**Advertising Department:**

Eastern Representative, S. I. CARPENTER, 170  
Summer St., Boston, Mass.

**British Representative:**

THE LOCOMOTIVE PUBLISHING CO., Ltd.,  
Amen Corner, Paternoster Row, London, E. C.

**Glasgow Representative:**

A. F. SINCLAIR, 15 Manor Road, Bellahouston,  
Glasgow.

**SUBSCRIPTION PRICE.**

\$2.00 per year, \$1.00 for six months, postage paid in the United States, Canada and Mexico. For other parts of the world, \$2.50, or ten shillings. Single copies, 20 cents. Remit by Express Money Order, Draft, Post Office Order or Registered Letter.

Mailing address can be changed as often as necessary—always give old and new address, and if you subscribe in a club, state who got it up. Please give prompt notice when your paper fails to reach you properly.

Entered at the Post Office, New York, as Second-class mail matter.

Copyright by Angus Sinclair Co., 1907.

For Sale by Newsdealers Everywhere.

## Infraction of Rules.

A few months ago there was a collision between two trains on the Grand Trunk Railway which resulted in the loss of three lives. The prosecution of the conductor of the train causing the accident resulted in his receiving a sentence of three years' imprisonment. A good deal of publicity has been given to the trial on account of the heavy sentence imposed and some misleading statements have been made in various quarters. RAILWAY AND LOCOMOTIVE ENGINEERING has taken some trouble to get at the facts of the case, and as far as we can learn them, they are as follows:

The accident occurred near Hespeler, in the province of Ontario, Canada, and was due to the fact that the train of which J. H. Thompson was conductor and M. B. Reid was engineer received orders to run from Harrisburg to Guelph Junction as a special, and that they did not keep clear of a regular train moving in the opposite direction, which, under the rules of the railway, they were required to do.

The conductor was prosecuted by the Crown, which is equivalent to a State prosecution in this country. The case was tried at the regular assize in the town of Guelph, Ontario, before the

Hon. Mr. Justice Riddell, of Toronto. The prosecution was not instigated by the railway company, and although the grand jury has found a true bill against Thompson for manslaughter, it was not pressed, but the lesser though grave charge of negligence appeared in the indictment, and there was a second count, charging him with a breach of the company's rules and regulations. The court, before the verdict was returned, withdrew the charge of negligence and the jury was asked merely to consider the breach of rules. On this count Thompson was found guilty, with a recommendation to mercy.

The court severely criticized the facts concerning the number hours worked by the prisoner and also his desire to make overtime. The judge stated that he would cause a copy of the trial proceedings to be sent to the law officers of the Crown, with a recommendation that all proper investigations be made and that the persons responsible for the long hours of service, irrespective of their positions, be proceeded against so far as the criminal law permitted. The judge did not hold that fatigue caused through working overtime, which was in this case voluntary, was in any sense a mitigating circumstance.

Before passing sentence the judge invited counsel to procure and lay before him for consideration any petitions or letters from any quarter setting out Thompson's character and standing in the community. Petitions numerous and influential were obtained and laid before the judge. A sentence of three years' imprisonment in the provincial penitentiary was given. No fine was imposed.

Against the engineer the grand jury found a true bill and an indictment containing the same counts as those preferred against Thompson. His trial was not proceeded with, and an adjournment was permitted until next assize, an application having been made and granted on the ground that it was not fair to the prisoner that two cases of exactly similar character should be disposed of at the same assize.

The judge was careful to point out that the law does not look upon a punishment as being in revenge for the transgression of its commands. It is designed for the reformation of the transgressor and as a warning to others. In the case before him the railway company had nothing to do with the prosecution. In fact, he indicated that the culpability or not of the railway in respect to long hours was a matter yet to be determined. There was no appeal against the decision of the court. Thompson was imprisoned, but has subsequently been pardoned.

## Driving Shoes and Wedges.

The severe service imposed on the driving shoes and wedges of a locomotive is such that their replacement is one of the items of expenditure at regular intervals, while their proper adjustment is a constant necessity in locomotive running. In locomotive construction the work of fitting and laying out the wedges may be said to be comparatively easy. The object aimed at is to have the axles of the driving wheels at right angles to the frames, the front pair of drivers being at a certain fixed distance from the cylinders, and the succeeding axle or axles at fixed distances. When the driving boxes have become worn and the wedges need repairing or replacing, it becomes a more involved mechanical problem, and a brief statement of the methods of operation cannot fail to be of interest to many of our readers.

A starting point of great importance in the operation is to secure a centre line on the frames between the two front pedestals, showing exactly where the centre of the axle should be. The blue prints will show the required distance from the centre of the cylinders to the centre of the axle, and generally the distance from the outer face of the cylinder head to the pedestal centre. In either case the position of the cylinders is rarely reliable, and should not be taken as a basis of new construction work. A good method is to start from a centre punch mark, centrally located between the frames on the saddle and about the same height as the top of the frames. An adjustable tram may be stretched from this point to the centre of the pedestals, where a temporary mark can be made on the top of the frame. The centre of the frame can readily be discovered by calipers. A straight edge laid across the frames at these points should be at right angles to the line of the frames, and measuring the distance to the cylinders, the central line of the pedestals can readily be located, and should be marked distinctly across the top and sides of the frame. When this line is positively established, it should form the basis of every other operation. Lines stretched through the cylinders should square exactly with this line, but it will be found that there are slight variations in the cylinder lines; that they are rarely exactly parallel to each other, and that the central line of the cylinders will vary slightly from the line of the frames lengthwise. Several causes lead to this, the chief of which, perhaps, is the fact that there is a gradual contraction of the metal in the front of a locomotive arising from its constant exposure to severe climatic influences, while on the other hand there is a slight expansion or spreading of the frames as we approach the back end of the locomotive. These variations may be insignificant, but they are sometimes con-



siderable, and lead to confusion if too many proofs are used in squaring the pedestal jaws.

It need hardly be stated that in repair work it is essential that the pedestal jaws should be carefully straightened to a face plate and should also be tried by a long straight edge crosswise, so that the faces of the pedestal jaws on both frames are true to each other. In fitting the binders or bottom braces they should be perfectly tight before being quite drawn close to the frames; in other words, an allowance should be made for the subsequent loosening and tightening of the binders. The shoes should also be a little longer than the exact distance between the binder and the inside of the top of the frame. The shoes should be carefully fitted to the rounded top of the pedestal jaw. The careful fitting of the shoes is of the utmost importance. When the shoes and wedges and binders are in place, before beginning to mark off the amount to be planed, or the amount to be used in liners, as the case may be, the wedges should be raised about five-sixteenths from the binders, allowing sufficient for loosening the wedges if necessary. A spreader, consisting of a piece of pipe with adjustable bolt, can be placed near the centre of the distance between the top and bottom of the frame, and a straight edge can be rested upon the spreader and held in place by small screw clamps. The sizes of the driving boxes being ascertained, we are now ready to lay off or adjust the front shoes. The central line of the pedestals being the chief factor in this operation, all measurements should be carefully tried by this line. In locomotives having a front truck centre, it is a common practice to test the position of the front shoes from the truck centre casting, but this is not so reliable as a point carefully marked on the saddle, and to which we have already referred. The new shoes should be marked at three different points, outside and inside, and from these three points all of the other shoes and wedges can be marked by a suitable tram corresponding to the distance between the axles and, of course, agreeing with the length of the connecting rods, taking care to add to or subtract from the markings as the varying sizes of the boxes may require. It should also be very carefully observed whether the driving boxes are bored exactly central, as the incidental wear sometimes compels a variation from the true centre. This is particularly true of the main drivers, where the tendency to wear irregularly is greatest.

When the shoes and wedges are planed or lined to their proper thicknesses they should be carefully fitted to a cross straight-edge reaching across the frames and filed till they are perfectly parallel to each other. In calipering the distance between the shoe and wedge, it is good

practice to leave them a little tighter in the bottom, as the tendency of the driving box is to close in the bottom, owing to the weight of the engine resting on the upper outer face of the driving box. The boxes should be tried in their places before being attached to the axles, as a slight alteration is much easier of accomplishment at this time than when the axles and wheels are in place.

In the adjustment of wedges while running a locomotive it may be said in a general way that there is a tendency, especially among the younger men, to meddle too much with the wedges. In the event of a driving box becoming heated, it is very necessary that the wedge should be loosened, otherwise they should be let alone. The position of the cranks is an important factor, especially in tightening wedges. The best practice is to have the cranks in the upper forward eighth position. At that point the driving box is readily held or moved hard against the shoe, and the wedge can be readily screwed up tight. A good practice is to try the flexibility of the wheel to rise or fall with two pinch bars on the rail, but where this is impracticable, it is safe to tighten the wedge, and after marking its position it should be carefully drawn down one-eighth. If the wedge bolt be loose in the wedge, it should be screwed back, so that the slack will not permit of a further lowering of the wedge, the pounding of the driving boxes in the wedges being one of the chief causes of wear and tear in the running of the locomotive engine.

#### Educating Apprentices.

It was highly creditable to the patriotism and public spirit of the members of the American Railway Master Mechanics' Association that the subject which received the greatest attention at the last convention was Apprentice Systems for Railroad Repair Shops. A very long and profitable discussion arose on that subject through a paper on the Apprentice System on the New York Central Lines, prepared by Messrs. C. W. Cross and W. B. Russell, being read. The paper described a highly generous system adopted by the New York Central people, which extends to all what has been known as the Vanderbilt Lines having approximately a total trackage of 11,866 miles, 4,937 locomotives and 191,654 cars.

The scheming of some plan to help apprentices to a scientific and engineering education has long been cherished by Mr J. F. Deems, general superintendent of motive power of the New York Central Lines, who himself passed through a machine shop apprenticeship and thoroughly realized the difficulties encountered by every apprentice ambitious to acquire intimate

knowledge of the service underlying the business he is trying to learn.

In studying out the details of a system of helping apprentices likely to produce satisfactory results, by no means an easy matter, for failures had been numerous in the past, Mr. Deems appears to have been guided in working out the plan by suggestions made in a paper read by Mr. G. M. Basford before the Master Mechanics' Convention in 1905, in which the assertion was made: "The engineering and the operating situation on railroads is in advance of its men, and in many ways the problem has outgrown both the individual and methods dealing with the individuals, and especially has it outstripped methods of preparing men for their work."

Although the introduction of a system of education for apprentices had as we mentioned, long been cherished by Mr. Deems, it was not till last year that any specific work was done. Then a department of instruction was instituted and two instructors were appointed to supervise and arrange the necessary details. The general plan is two-fold, and provides for shop instruction of the apprentice in the trade he is learning and also for his instruction in mechanical drawing, practical mathematics and shop problems during working hours while under pay.

This movement is highly creditable to the New York Central Railroad Company and to the officials who guided it into operation and we have no doubt that it will eventually prove as profitable to its promoters as it will be beneficial to those who enjoy its instruction. The plan of giving special education to apprentices is by no means a novelty for several railroad companies have for years provided that shop apprentices with instruction that does not differ materially from that introduced by the New York Central system.

In our December issue of 1905, Mr. James Kennedy had an article on Apprentice Machinists, Ancient and Modern, in which he expatiated on the advantages a modern apprentice enjoys if he is ambitious to acquire the skill and knowledge that raise men from lowly to high positions. In that connection he said: "Mr. William McIntosh, superintendent of motive power of the Central Railroad of New Jersey has formulated an admirable system of instruction at the Elizabethport, N. J. shops, which is being carried into effect under the skilled direction of Mr. G. L. Van Doren, the superintendent of the works. Reports of the progress of the apprentices, of whom there are over sixty, are made regularly. Efficient and rapid progress are properly

encouraged, while dullness and carelessness are induced to better themselves. In addition to the regular routine of mechanical work, a school has been established where mechanical drawing, a system of theoretical and applied mechanics, especially devoted to the mechanical appliances used in railway and locomotive engineering is taught. The apprentices are divided into three classes, and certain days are allotted to each class."

This instruction class has been long enough in operation that Mr. McIntosh was able to tell during the discussion on educating apprentices that their experience had been very satisfactory and he felt that educating the apprentices would prove a good investment.

Within the last three years we have been able to comment favorably concerning the successful operation of instruction classes connected with the machine shops of railway companies conspicuous among them having been those connected with the Grand Trunk at Montreal and with the Missouri Pacific at Sedalia, Mo. The comments indicated that a widespread movement existed among railway companies to aid their young employees and themselves by the force of education. It is well known that the keen esprit de corps which exists on the Pennsylvania railroad system has been greatly promoted by the company lending a helping hand in the education of their apprentices and it is certain that other railroad companies can profit in the same way by adopting a similar course.

In *Sartor Resartus* Carlyle says of his alma mater: "It is my painful duty to say that out of England and Spain ours was the worst of all hitherto discovered universities. This is indeed a time when right education is as nearly as may be impossible, however in degrees of wrongness there is no limit. Poisoned victuals may be worse than hunger. It is written, when the blind lead the blind both shall fall into the ditch; wherefore, in such circumstances may it not be safer if both leader and led simply sit still."

The ordinary railroad machine shop has been much the same kind of medium for instruction of apprentices as Carlyle's university was to the great philosopher, only the youths entered to learn a life's business generally found no leaders, not even blind ones. They have been permitted to grope their way through darkness or on unskilled work and emerged from their apprenticeship inferior workmen full of bitterness towards the employers who had failed in treating the young men as they had a right to expect. It was high time that railroad companies were making an earnest move to help the young men

who in a few years will take a lead in expressing loyalty or disloyalty towards their old employers.

#### Inconclusive Tests.

While we entertain the highest admiration as a rule for the various machines and apparatus designed for testing railroad material we are inclined to think that too much faith is given to the result of tests that differ materially from experience in service.

This tendency was emphasized in a report on Brake Shoe Tests prepared by Mr. F. W. Sargent, of the American Brake Shoe & Foundry Company, and submitted to the last Master Car Builders' Convention. The most important parts of Mr. Sargent's paper read:

"The M. C. B. record of shoe tests, while most important and valuable, will remain incomplete until checked up by service tests. The brake-shoe testing machine records results under ideal conditions—a steady wheel moving true with a constant uniform braking load and perfect contact between shoe and wheel, with clear, dry surfaces in contact under practically uniform climatic conditions.

"In actual service we have the reverse, namely, an unsteady wheel pounding along over uneven track, more or less elasticity in brake beams and brake connections, and fluctuation in braking pressure, coupled with the varying contact between wheel and shoe with extremes of climatic conditions from cold to hot and wet to dry.

"The test wheel is uniform in its bearing against the shoe, and always moving in the same direction, the projections tend to bend away from the shoe and the surface of the wheel to polish up and to smooth over and afford a better contact than in the case of the wheel in service conditions. With the ordinary car wheel the unflanged brake shoe covers that part of the wheel not in contact with the rail, as well as that part of the wheel which is in contact with the rail; so that there are two distinct surfaces under the shoe. The side motion of the brake shoe is continually varying the amount of contact between the shoe and these two surfaces, while the inequalities of track condition and the pounding of the wheel cannot do otherwise than break the grip of the shoe on the wheel, all of which means that the actual coefficient of friction from the service tests is much less than that indicated in the shop test."

One might as well expect to thrive physically while his portion of food is being eaten by others as to expect mental development and not do his own thinking.—S. C. Morse.

#### The Railway Service.

There is no occupation so exacting in its demands upon the very best qualities inherent in the better class of working men as the railway service is. The amount of physical labor performed by a fireman of a modern heavy freight locomotive, for instance, is enormous, and while the same may be said of firemen in the marine service, the hours of labor of railway men are usually longer, besides in the marine service, generally speaking, there are days and sometimes weeks in port where there are periods of comparative leisure. In comparison with every other kind of responsible work, his work is underpaid.

Not only is this the case but the feeling of the general public toward railroad men is not as kindly as it might be. Lord Claude Hamilton, speaking in London recently, said that "the railway interest was a vast power, and a great organization, forming one of the most important facts in the daily life of the nations which had reached a high state of civilization. The organization of the railway interest was indeed so vast and complex that its suspension for one day would produce dire confusion on the commerce and trade of the world. Considering all that the railways had done and did for the development of the resources of the countries they served, and the marvellous facilities they offered to the traveling public, those responsible for their working received but a small measure of gratitude. The railway interest, in spite of its magnificent services to the public, was not popular. If anything went wrong there was a flood of public abuse and indignation, whilst when everything went right, as was generally the case, the railway men received no credit. This undeserved unpopularity had helped, however, to unite railwaymen in all countries in one great brotherhood, and in no other service was this feeling of brotherhood more highly developed."

It is refreshing to hear a public man speaking in this way, and thus recognizing the value of the services performed. Railway men have a very strong fellow feeling for one another, though divided by seas and mountains, and the fact that RAILWAY AND LOCOMOTIVE ENGINEERING receives the warm welcome it does in foreign countries is in part a proof of the kinship to which Lord Claude Hamilton refers. Not only is the interchange of the literature of railroading a corroboration of this statement, but the many pleasant visits to this country paid by eminent railroad men from other lands and the equally cordial reception which representatives from our shores receive abroad, is evidence of the existence of helpful and

healthy community of interest among railroad men wherever the iron horse is harnessed to the wheels of commerce.

#### Bursting Flue.

An interesting story of an explosion from a locomotive boiler, due to faulty fitting of a ferrule in one of the tubes, comes from South Shields in England. There were 143 solid drawn tubes, each 2 ins. outside diameter, made of an alloy known as red metal. Their thickness was what is known as No. 8. The tubes were expanded into the plates and fitted with iron ferrules at the fire box end. A leaky flue was driven back further through the flue sheet, from the smoke box end and a ferrule driven in. The tube was reduced in thickness by the ferrule not being fairly driven in place. It thus had a cutting action, reducing the thickness of a part of the flue. The ferrule was over an inch in length and tapering one-sixteenth. It was driven in rough as it came from the hammer, and no care had been taken to see that it was entered straight. Such ferrules, if used at all, should be trued up on the lathe and have their inner edges slightly bevelled inwards. The fractured part had been reduced to about one-twentieth of an inch in thickness, the normal thickness of the flue being about one-eighth. The engineer and fireman were both severely scalded by the explosion.

#### Composition of Rails.

The chemical composition of steel rails has been the subject of much discussion among the leading railway men both in America and Europe for some months past. Attempts have been made to arrive at a universal specification or composition for rails which would suit all cases, but there is little prospect of this conclusion being arrived at. The general complaint that rails are less durable than they were twenty-five or thirty years ago is true, because the excessive traffic and increased weight of rolling stock has a much larger wearing effect upon the rails than lighter cars and less traffic had. The ever varying conditions, the kind of ores available, the processes of manufacture, the weight of rail required for certain kinds of traffic, differ in many cases, and must all be considered with a view of obtaining the best results.

In cold climates the high percentage of rail fractures is largely owing to the presence of phosphorus, and in spite of its good wearing qualities it is generally agreed a low phosphorus limit is best adapted for rails subjected to severe frosts. This is more readily made possible with the basic than with the acid processes, especially with the basic open-

hearth process. The presence of sulphur is the cause of incipient flaws in rails, which, though not apparent in rolling, may develop under wear into serious flaws, and hence the presence of excessive sulphur should be avoided.

No satisfactory method of testing rails has yet been discovered that in any way compares with actual experience in service. This arises largely from the fact that irregular methods are used in the manufacture of rails, and particularly in the introduction of silicon, a high percentage of which, although giving excellent wearing results, is the cause of brittleness and irregularity. This is due in many cases to the silicon being left in the steel from the pig iron, in which case the quality of rail is very variable, depending on the heat of the charge which causes the irregularity. When the iron has not been completely converted into steel, the metal is always of a brittle character. Silicon should be completely eliminated from the pig iron and a known quantity of silicon carefully added; the silicon has then the effect of toughening the steel, this being largely due to the more complete removal of gases and oxide from the steel. Manganese has also a very beneficial effect by healing up small flaws in the metal, and produces a smoothly rolled surface. Manganese should be sparingly used, as its chief use is in facilitating clean rolling.

#### Instruction of Firemen.

During a discussion at the last Master Mechanics' Convention on a paper relating to apprentices, Mr. E. W. Pratt of the Chicago and North-Western inquired if the apprenticeship system would ultimately embrace the instruction of firemen. The answer given was that throughout the New York Central System of Railroads the local firemen are trained, educated and examined for promotion by a board of examiners composed of master mechanics and road foremen of engines. We are afraid that the education given to firemen is very far behind that which apprentices are enjoying, and that it entirely depends upon what they can glean for themselves. The examination preliminary to promotion is real enough, but it does not convey with it any preliminary instruction to enable candidates for promotion to pass the examination.

The system of education for foremen is entirely one-sided. Most of them know what questions will be asked at the different examinations, but no information has been forthcoming about the answers expected to the questions. We have done our best to provide the proper answers, but the railroad officials might do something to instruct the men in the knowledge they are ex-

pected to possess. It is all very well to establish an elaborate system of instruction for apprentices in shops, but we consider that the arrangement will always be one-sided until a branch is added that will deal with the instruction of firemen.

#### Book Notice.

Railroad Men's Catechism, by Angus Sinclair. An instructive book for Enginemen, Trainmen, Signalmen and every person connected with the movement of trains. Published by the Angus Sinclair Publishing Co., 136 Liberty street, New York. 16 mo. 216 pages. Cloth, \$1.

This book, as its name implies, consists largely of a succession of a series of questions and answers for the examination of engineers and firemen, to which is added questions developed from a code used by the Traveling Engineers' Association and also from a code of the American Railway Association, to which is super-added a variety of new questions and other original matter of value to railroad men. The form of the book is admirably adapted for the purpose intended, being of a size suitable to be carried while at work. The presswork and binding are excellent and the book is in every way a fine example of the printer's and binder's art.

The author of the work is too well known in the railroad world to need other than the mere mention of his name. Mr. Sinclair was the first writer in this particular form of railroad instruction books in America, and although he has had many imitators, none have approached the degree of popular favor with which his writings have been received. While employed as an engineer on a Western road in the early 70's he began writing from actual experience, and a series of contributions from his pen attracted the attention of the leading railroad managers.

Part of Mr. Sinclair's work was made use of in pamphlet form. In this way much of his earlier work appeared in book form without his supervision or sanction. Mr. Sinclair did not complain, as authors usually do, under such treatment. It is said that when Alexander gave away cities and towns to his lieutenants he was asked what he intended to keep to himself. He replied that he had kept his sword. Mr. Sinclair kept his pen and in addition to adding to his daily notes, he attended the classes of the Iowa University in his leisure hours and made rapid progress in chemistry and kindred studies. His first book, "Locomotive Engine Running and Management," immediately became a standard text book on railways, and has passed through twenty-five extensive editions. Twenty years ago Mr. Sinclair established RAILWAY AND LOCOMOTIVE ENGINEERING, a monthly mag-

azine devoted to the instruction of railroad men in the use of appliances used on railways. In this periodical the series of questions and answers was begun which forms the basis of the present work. It may be added that while much of the present work has appeared in print already, it is now for the first time presented with logical sequence and in concrete form. The work has not only been carefully re-written with a view to meet the expanding requirements of twentieth century practice, but the original writings have been classified so that the work is really the wide experiences of more than thirty years' constant study and association with the mechanical side of railroad operations, and the whole placed in interesting form so that engineer and fireman will find daily practice described and emergencies provided for. The standard

#### Consolidation for Central of Georgia.

These engines, built by the Baldwin Locomotive Works for the Central of Georgia Railway, are of the 2-8-0 type, with simple cylinders 20 x 28 ins., driving wheels 56 ins. in diameter, and a working pressure of 200 lbs. to the sq. in. The calculated tractive power is about 34,000 lbs., and the factor of adhesion is 4.21.

The link is suspended immediately back of the second driving axle, and the rocker shaft is between the first and second pairs of driving wheels. The valve is the ordinary D-slide type balanced. The transmission bar passes above the intermediate axle. The leading truck is equalized with the first and second pairs of driving wheels. The third and fourth pairs of wheels are equalized by beams placed over the boxes and connected

frame, arch bar trucks. The tank contains 6,000 lbs. U. S. gallons of water and 8 tons of coal. A few of the principal dimensions are as follows:

Boiler—Material, steel; thickness of sheets,  $\frac{5}{8}$  in.; and 11-16 in.; fuel, soft coal; staying, radial.  
 Fire Box—Material, steel; length, 96 $\frac{1}{2}$  ins.; width, 66 ins.; depth, front, 66 $\frac{1}{2}$  ins.; depth, back, 57 $\frac{1}{2}$  ins.; thickness of sheets, sides,  $\frac{3}{8}$  in.; thickness of sheets, back,  $\frac{3}{8}$  in.; thickness of sheets, crown,  $\frac{3}{8}$  in.; thickness of sheets, tube,  $\frac{1}{2}$  in.  
 Water Space—Front, 4 ins.; sides, 3 ins.; back, 3 ins.  
 Tubes—Material, steel; wire gauge, No. 12; diameter, 2 ins.  
 Engine Truck Wheels—Diameter, 33 ins.; journals, 5 $\frac{1}{2}$  by 10 ins.  
 Wheel Base—Total engine and tender, 53 ft. by 9 ins.  
 Weight—On driving wheels, 143,290 lbs.; on truck, 20,100 lbs.; total engine, 163,390 lbs.; tender, about 283,000 lbs.; service, freight.

#### Fair Exchange.

In regard to contracts made by the Grand Trunk with newspapers to ex-

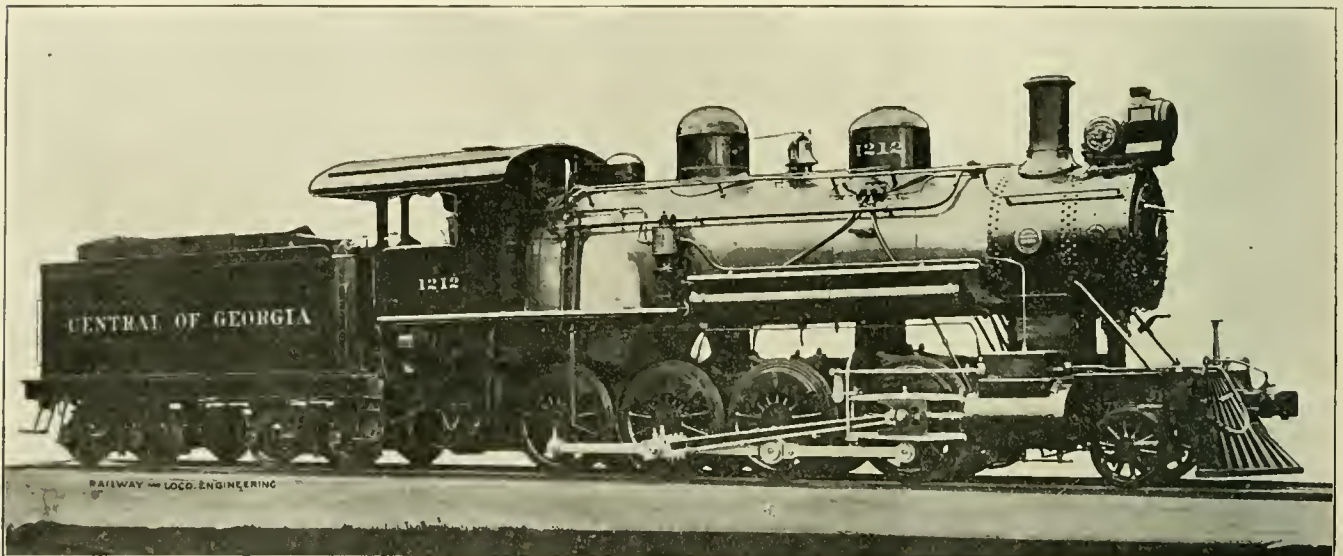

HEAVY 2-8-0 FOR THE CENTRAL OF GEORGIA RAILWAY.

F. F. Gaines, Supt. of Motive Power.

Baldwin Locomotive Works, Builders.

code of train rules dealing with visible, audible and communicating signals is given, and also complete illustrations showing the engine and train signals displayed and carried on the road. Burning oil fuel in locomotives is the subject of a special section which describes actual experience by the Southern Pacific Company and furnishes complete information on a subject of growing importance, especially in the West and Southwest.

In conclusion it may be justly claimed that the book presents the subject of the many duties of the modern railroad man in the fullest and best form. The author's style is the best adapted to the actual worker. It is simple and direct, and while there is much of learning and scientific information in the pages of the book, the facts are always clearly presented and the most inexperienced reader is never left in doubt, but led from question to question in a way that is as interesting as it is instructive.

C. L. W.

through an inverted leaf spring. Coiled springs are used to support the frame at the other ends of the beams. All the wheels are flanged, and the total wheel base of the engine is 24 ft. 3 $\frac{1}{2}$  ins., the driving wheel base being 16 ft. In these engines the various details are as far as possible interchangeable with the 4-6-2 engines built for this road by the Baldwin Works some time ago.

The boiler is one of the extension wagon top type, and is 61 ins. in diameter at the smoke box end. The heating surface is in all 2,307 sq. ft. The tubes give 2,161 and the firebox 146 sq. ft. The grate area is 44 sq. ft., and this gives a ratio of 1 to 52. The roof sheet is level, but the crown sheet slopes slightly toward the back, giving an average steam and water space of about 20 $\frac{1}{2}$  ins. The back sheet slopes forward at the top. There are 283 tubes in the boiler, each 14 ft. 8 ins. long.

The tender is of the ordinary type, steel

change advertising for transportation, Mr. George T. Bell, general passenger agent of that road, says:

"The contracts were passed upon by Judge Kretzinger of Chicago, our general counsel for the United States. As he is recognized as a good constitutional lawyer, it does not seem that we have anything to fear. The exchange of advertising at the full card rates for transportation at full fare is a business proposition in which full value is exchanged on both sides."—*N. Y. Commercial*.

#### Daily Press Railroad News.

A recent press dispatch from Port Arthur, Ont., says: The Superior Limited of the Canadian Northern Railway had really a remarkable experience near Kashabowie on Saturday, when it ran into a cloud of white moths which was so dense that they obscured the view of the engine crew, and covered the tracks so thick that the train was stalled.

# Correspondence School

## Fourth Series—Questions and Answers.

66—What would you do with a broken cylinder head?

A.—Supposing the front cylinder cover or head was broken I would take off the broken parts, disconnect the main rod at the butt end, push main rod, crosshead and piston forward as far as they would go and block crosshead in guides, and so carry the main rod in the guide yoke. Disconnect valve rod, place valve on its centre so as to cover the ports, clamp it there, shut off lubricator on the disabled side, and run engine on other side.

67—With a broken valve yoke?

A.—Disconnect valve rod, centre valve and clamp it there, open cylinder cocks on that side, shut off lubricator on that side and oil cylinder before starting again, through plugs intended for indicator connections, if there are any, or slack off front cylinder cover and oil cylinder thoroughly.

68—What would you do with a top rocker arm broken?

A.—Proceed as outlined in answer to question No. 67.

69—How do you fix broken steam chest if steam leaks out badly?

A.—If steam chest leaked badly from steam chest, I would open smoke box and slack off bolts of steam pipe at lower end on disabled side and slip a piece of sheet steel (such as could be cut from an old coal scoop) in the joints and tighten joint again and proceed, keeping the lubricator working on disabled side.

70—How and when do you block the crosshead when disconnected?

A.—It is always safe to block a crosshead when disconnected, but with the conditions given in question No. 66 it is possible to push crosshead, piston, etc., ahead and disconnect valve rod and place valve so that steam will be admitted to the back end of cylinder, and clamp valve there, so that the steam pressure will keep piston, crosshead, etc., at front end of cylinder. One objection to this is that valve clamp is usually made so as to centre valve, and when blocked in any other position the clamping may not hold well and allow valve to shift and to move piston, and if main rod is being carried in guide yoke, butt end of rod would be struck by main crank pin. With broken cylinder covers it is possible to run with valve clamped in centre and main rod up and piston moving if cylinder is well oiled and broken parts removed and cylinder covered so grit, dirt and cinders cannot get in.

71—What would you do if main rod strap or crosshead should break?

A.—If main rod strap broke proceed as outlined in answer to question No. 66. If crosshead was broken, take down main rod, push crosshead to one end of guides, block it there, disconnect valve rod, centre and clamp valve, shut lubricator on disabled side.

72—What is done if side rod or back pin breaks?

A.—If side rod or back crank pin breaks, take down side rod on both sides if an ordinary 4-4-0 engine. If on a mogul, ten-wheeler or 2-8-0 engine, take down back section of rod on both sides, noting the position of knuckle joints in side rod. If knuckle is in front of next

cause on the good side at either forward or back centre there is nothing to ensure a pair of wheels with one side rod attached to one pin, going round in the right direction. A sudden slip just at the dead point might turn the wheels with one side rod, round the wrong way. When rods are up, on both sides, the pins on one side are in mid-stroke when the pins on the others are at the dead points, and no mishap can occur; when one side rod is down, the dead points are where trouble may occur.

75—What is the effect of sanding the rail while engine is slipping without first shutting off steam.

A.—If wheels are rapidly revolving with steam on, and sand is applied to



STATUE OF GEORGE STEPHENSON IN THE STATION OF THE L. & N. W. RY., EUSTON, LONDON.

crank pin, then two sections of side rod must come down.

73—Can all four-wheel switch engines be run with the side rods down?

A.—No. In some switch engines it is possible for the crank pin of the leading wheel to foul the crosshead unless pin passes crosshead exactly at end of stroke. In the majority of engines there is clearance, but in case of trouble it is well to look for this condition.

74—Why do you take rods down on opposite side to that broken?

A.—You take down side rod or corresponding section of side rod on good side, as you do on the disabled side, be-

cause on the good side at either forward or back centre there is nothing to ensure a pair of wheels with one side rod attached to one pin, going round in the right direction. A sudden slip just at the dead point might turn the wheels with one side rod, round the wrong way. When rods are up, on both sides, the pins on one side are in mid-stroke when the pins on the others are at the dead points, and no mishap can occur; when one side rod is down, the dead points are where trouble may occur.

75—What is the effect of sanding the rail while engine is slipping without first shutting off steam.

A.—If wheels are rapidly revolving with steam on, and sand is applied to

76—Is it good policy to allow sand to run from one pipe only?

A.—No; it is bad policy for practically the same reason as outlined in answer to question No. 75.

77—How do you block up an engine for a broken driving spring or hanger?

A.—Jack up the engine on the disabled side in most convenient place, and put a block of wood between top of box and underside of frame, the object being to make the box carry the weight from the frame directly, as the spring has become

useless. The end of the equalizers next the broken spring or hanger will be found pressing hard against the frame, and it should be drawn away from the frame sufficiently to put a nut or other suitable piece between end of equalizer and frame. A chain and jack, or by suitable bar leverage the equalizer may be sufficiently eased to get nut or block in place. An engine so blocked must be run carefully, as the driving box is very liable to heat, and must be well and constantly oiled.

78—With broken equalizer?

A.—If the equalizer key has broken it is possible to clamp the equalizer so as to hold it approximately in place. If the equalizer is broken entirely, the free ends of the driving springs must be clamped down and chained to the frames, or blocks be put on top of the boxes and under frame. Care must be taken in any case to see that lubrication is given freely.

79—With broken engine truck spring or hanger?

A.—Jack up engine on disabled side and block on top of engine truck box and below engine truck frame. If spring is broken badly, block on top of both boxes on disabled side. If the hanger is broken, block on top of box next to it and chain free end of spring up to the engine truck frame. Look well to lubrication.

80—With broken engine truck centre pin on Mogul, what is to be done?

A.—The breaking of the engine truck centre pin on a Mogul can be temporarily repaired by jacking up the engine, removing the broken pin and chaining up the free end of the equalizer by a chain passing up through the hollow centre casting and secured by a bolt placed horizontally on top of the centre casting. Another method would be to block the equalizer down under the cylinder saddle as near to the cross equalizer as possible. The engine must be run most carefully under these circumstances, as the guiding influence of the engine truck has practically disappeared.

81—With broken intermediate equalizer on Mogul?

A.—The broken intermediate equalizer lets down the frame on the main and the back driving boxes on one side. Block on top of both boxes, as both driving and trailing driving springs are useless. Proceed with care, as both boxes are liable to heat.

82—What do you do when a tire breaks and comes off the wheel on standard engine?

A.—Take down the cellar and put a block of wood in the cellar, cover with well oiled packing, then block up the box of the disabled wheel by inserting a nut or other suitable piece on top of the pedestal binder and under the box. This will carry the weight of the wheel clear of the rail. Disconnect side rods and

main rod at butt end, push rod, crosshead, etc., forward, block crosshead, disconnect valve rod, centre valve and clamp, shut off lubricator and proceed very cautiously.

83—With front tire on Mogul or ten-wheel engine?

A.—Proceed as outlined in answer to question No. 82, as far as the blocking of the box is concerned, and in addition disconnect front section of side rod on both sides and run cautiously, as the disabled wheel is no longer able to help in guiding the engine round track curving toward the other side of the engine.

84—Main tire on Mogul?

A.—Proceed as outlined in answer to question No. 82.

85—With the back tire on Mogul?

A.—Proceed as outlined in answer to question No. 82, and in addition take down back section of side rod on both sides.

86—With both back tires on Mogul?

A.—Block up both back wheels, disconnect back section of side rods on both sides; but it is not necessary in this case to put block in cellar, as these wheels will not revolve. The main drivers will have to be carefully oiled, as they will carry more weight than usual. Where the overhand is long it is necessary to carry some of the weight of the engine on the tender, and this may be done by chaining two pieces of rail to the back portions of the engine frame, one rail on each side. Each rail chained in two places, so as to make an extemporized extension of the frames, and jack the engine high behind and chain from the end of one projecting rail over end sill of tender and down to other projecting rail. Lower engine and part of the weight of the engine will be transferred to front of tender. The disabled wheels will ride clear of the rails. Look after the oiling of the journals on the tender on account of the increased weight so carried.

87—With back tire or back driver broken off, how do you fix engine so you can back around curves when necessary?

A.—Proceed as outlined in answer to question No. 86, but back very slowly and cautiously round curves with engine in this condition.

88—At what points is weight of engine carried when blocked up over the back driving box?

A.—The weight is carried directly by the frame over the back box and by equalizer pivot, and by the other springs and hangers in the usual way.

89—If driving box or brass breaks so it is cutting the axle badly, what can you do to relieve it?

A.—Take down the driving box cellar and put block of wood in the cellar and cover with well oiled packing. Run wheel up on wedge, or block so as to carry the box up in the jaws, put nuts

or other suitable pieces on top of pedestal binder and below box. When the wheel comes on the rail again part of the weight will be taken off the defective brass; oil thoroughly and often and proceed carefully.

90—Do you consider it an engineer's duty to have suitable hardwood blocks on his engine to use in case of a breakdown?

A.—Yes.

## Elements of Physical Science.

### IV.—GRAVITY.

The tendency of bodies when unsupported is to fall to the ground. This is called gravity, and this law of attraction is universal. It is not confined to the surface of the earth alone, but extends through space, and, as has been already stated, is the great agent by which the stars are kept in their spheres. This law of gravitation is a constant principle and acts instantly, and is not lessened by the interposition of any other substance, and is also entirely independent of the nature of matter. It has been scientifically demonstrated that the action of the sun is found to be the same on all of the heavenly bodies. It is this force of attraction or gravitation that keeps all movable bodies on the surface of the earth from falling into space.

It may be noted that the force of gravity increases as the amount of matter increases, and the force of gravity decreases as the square of the distance increases. In regard to the planetary system of which the earth forms a part, the sun is 800 times greater than all the planets put together. It is on this account that its attraction is felt by the remotest bodies of the solar system. Weight of bodies is simply a measure of the force with which bodies are drawn towards the earth, and if the earth contained twice the matter which it now contains all bodies movable on its surface would be found to have twice their present weight. As gravity decreases as the square of the distance from the earth's centre increases, it follows that bodies become lighter in proportion to the distance they are removed from the earth's surface. A mass of iron weighing one ton on the earth's surface would be found at the distance of 4,000 miles to weigh only a quarter of a ton. The varying weight on the earth's surface is small. Four miles above the surface of the earth a body weighing 1,000 pounds becomes only two pounds lighter.

### FALLING BODIES.

All bodies acted on solely by gravity fall to the earth with the same velocity. It is true that a metal ball will fall faster than a feather, but this is not owing to a variation in the fixed law of gravitation, but arises from the effect of the atmos-

phere hindering the flight of the lighter body. The descent of a parachute is a good illustration of this interference of the atmosphere with the gravitation of expanded bodies. The effect of the expansibility of bodies on falling can be exactly determined, and, taking the parachute as an illustration, it will be found that in order to deter the falling of an ordinary man to a speed of safety the parachute would require to be about 22 ft. in diameter.

Falling bodies have an accelerating velocity, or, in other words, gravity gives a falling body a certain velocity in the first second of its descent; this is increased in the next second, and so on till the falling body reaches the earth. There are several methods whereby the velocity of falling bodies can be readily determined, the simplest being that formulated by experiments with Atwood's machine, a contrivance whereby two small weights are balanced over running pulleys and a slight addition being made to one of the weights the pulleys are set in motion, and are so arranged that the heavier of the two weights is 64 times as long in descending a measured distance as it would be if dropped freely in the air.

It is found with this machine that if the distance through which a body falls may be reckoned, as 1 during the first second of time, that traversed in the 2d will be equal to 3; that in the 3d, 5; that in the 4th, 7, and so on in the continuing series of odd numbers. Repeated experiments have demonstrated that solid bodies of matter falling to the surface of the earth have a velocity of a little more than 16 ft. during the first second; in the next second the body will pass through 48 ft. of space; in the third second the distance traversed is 80 ft., and so in an increasing ratio till the surface of the earth is reached.

From this formula the velocity of falling bodies at any particular part of their flight can be determined, or the total distance traversed can be obtained; thus to find the velocity of a falling body at the termination of any second of its descent all that is necessary is to arrange a series of odd number, these being 1, 3, 5, 7, 9, 11, etc., and suppose we desire to ascertain the distance traversed during the fifth second. The fifth figure in the series being 9, we multiply that by 16, which gives 144, being the distance in feet. Again, if we desire to ascertain how far the weight has traveled during 5 seconds, we multiply 16 by the square of the given number of seconds; squaring 5 gives 25, which, multiplied by 16, gives 400, the distance in feet which the body has passed through in 5 seconds. These rules apply to bodies acted upon by gravity alone. A body thrown downward with force equal to 50 ft. per second will retain this velocity in addition to the gradually in-

creasing velocity acquired from gravity.

In this connection it should be remembered that the density of the falling body and the atmospheric resistance slightly affect the velocity. Experiments at St. Paul's Cathedral, London, and at the Washington Monument show a slight variation from Atwood's formula. At the latter place a ball dropped from a height of 555 ft. took a little over 6 seconds in falling to the ground; whereas the calculations give 576 ft. as the distance traversed by falling bodies in 6 seconds.

#### ASCENDING BODIES.

Falling bodies increase their velocity 32 ft. per second; so ascending bodies, being acted upon by the same force, lose a like amount until they are brought to rest. If the initial velocity is known and divided by 32 we find the number of sec-



SHORE SPAN OF THE KROONSTAD BRIDGE WRECKED BY DYNAMITE.

onds in which the body will continue its upward flight. On this principle a bullet shot vertically upward should descend at the same velocity and with the same force as it had when originally discharged. The resistance of the air, however, lessens its force considerably, just as a projectile thrown through the air is borne some distance in a straight line, but as its velocity diminishes the force of gravity which impels it towards the earth, and the resistance of the air which tends to bring it to rest, causes it to move in a curved line, called the parabola.

Genoa and Milan are to be connected by an electric railroad 85 miles long. Its cost will be high owing to the nature of the country through which the line will pass. It will require 19 tunnels, one of which will be 12 miles long. There will be 372 bridges, and the road will be six years in course of construction.

## Questions Answered

#### HARDENING BRASS.

(64) J. G., Wheeling, W. Va., asks: Is there any process for hardening or softening brass?—A. Brass can be hardened by subjecting the metal to great pressure, or by blows of a drop hammer. It may be softened by heating to a cherry red and cooling in water.

#### LEAKY BY-PASS VALVE.

(65) F. S., New Haven, Conn., asks: If a by-pass is leaking how do you test for it?—A. Move the engine or reverse lever or both till the rocker arm is plumb. This will cover the valve ports. Then open the cylinder cocks and throttle. The leaking by-pass valve will allow the steam to pass through to the cylinder cock on the side on which the leaking valve is located. The valve may be closed by inserting a blind gasket.

#### WEIGHT OF STEAM.

(66) W. W., Jersey Shore, Pa., writes: In your calculations in RAILWAY AND LOCOMOTIVE ENGINEERING you refer occasionally to the weight of steam. What weight of steam will be evaporated from one pound of water?—A. The weight of steam will correspond exactly with the weight of water from which it came. This can be readily proved by confining the water in a vessel from which the steam cannot escape. The weight remains the same after the water has been changed into steam.

#### WHAT IS BABBITT?

(67) J. R. K., Dunkirk, N. Y., asks: What is the best mixture to form babbitt metal?—A. In a thousand parts a good mixture of metals composing babbitt is 880 parts of tin, 74 parts of antimony and 37 parts of copper. There are cheaper mixtures sometimes called babbitt, the commonest consisting of eight parts of lead and one of antimony. This is not, properly speaking, babbitt metal at all, but lead slightly hardened. It has the quality of not contracting in cooling.

#### FLEXIBILITY OF AXLES.

(68) A. Y., Norristown, Conn., writes: Is there any advantage gained besides reduction of weight in making an axle smaller in diameter at the center than towards the ends?—A. The theory is that an axle with the center reduced in diameter at the middle is more flexible than when the diameter is uniform. This flexibility is believed to prevent breakage.

#### MOUNTING DRIVERS ON AXLES.

(69) E. P. M., Swissvale, Pa., writes: What is the practice of locomotive builders and railroad shops for pressing drivers on axles? I would

like to know the pressure in tons, also the allowance in thousandths per inch in diameter of axle over hub bore. A.—The axle should be pushed on with a pressure of about 10 tons for every inch of diameter. A 4-inch axle is usually turned .015 of an inch diameter larger than the hole into which it is to be fitted and so on in an increasing ratio according to the size of the axle. An 8-inch axle would thus require to be about thirty one-thousandths larger than the hole in the wheel.

POWER TO MOVE AND STOP A CAR.

(70) J. G. A., El Paso, Tex.—(1) About how much power per ton is required to start a car from a state of rest on level track?—A. About ten pounds.

(2) Would an invention that utilizes for starting the power absorbed in stopping a car be a new and useful invention?—A. No. It would not be new, because thousands of such things have been patented. It would not be useful because inventions of that character have been proved to be impracticable.

TIRE SHRINKAGE ALLOWANCE.

(71) E. P. M., Swissvale, Pa., asks: (1) What is the allowance for shrinking tires on wheels.—A.—The report of the committee of the Master Mechanics' Association, presented at the Convention held at Atlantic City this year, dealing with this subject was in part as follows: "Your committee made a report of shrinkage allowance for tires in 1905 to this association. The suggestions of the committee at that time were as follows; Shrinkage 1-80th of an inch per foot in diameter for cast iron and cast steel centres less than 66 ins. in diameter. Shrinkage 1-60th of an inch per foot in diameter for centres 66 ins. and over in diameter. Minimum thickness of tires should be established, due consideration being given to the diameter, service and weight per wheel."

(2) What is the fiber stress per square inch of tire cross section allowable to be run with safety?—A.—The same report, referred to above, quotes the tensile strength and elongation given in Bulletin No. 14 of the American Society Testing Materials as follows:

SERVICE.

	DRIVING.		TRUCK AND TRAILING.	
	Passenger. Lbs.	Freight. Lbs.	Switching. Lbs.	Trailing. Lbs.
Tensile strength per square inch not less than	100,000	110,000	120,000	110,000
Elongation in two inches not less than	12 Per cent.	10	8	10

SQUARE INCHES AND INCHES SQUARE.

A. F. M., Cincinnati, writes: There appears to be confusion among people concerning the meaning of the terms square feet or inches and feet or inches square. Is there any recognized rule on the subject?—A. Square feet or square inches indicate spaces of certain

general dimensions, as 144 sq. ins., for instance, which represents a space 12 ins. long and 12 ins. wide, but its dimensions may be 18 ins. long by 8 ins. wide, representing the same area. When, however, the term 18 ins. square is used it means a square having a side of 18 ins., or 324 sq. ins.

BRITISH AND U. S. GALLONS.

(72) R. A. S., Binghamton, N. Y., asks: What is the difference between the U. S. gallon and the British gallon? Why should they not be uniform?—A. Why certain things are as they are is sometimes what no fellow can understand, but has to take them for granted. The U. S. gallon is 231 cubic ins. and holds 8 2/3 pounds of water. The British gallon is 277.27 cubic ins. and holds 10 pounds of water. The United States gallon is based on what was known in England long ago as the Winchester wine measure. Winchester was the capital of England at one time and had its own privileges and practices, among them being the small wine measure. When British wine merchants began working into a business with Virginia they found it profitable to sell wine to the colonists measured on the old Winchester gallon, and so by degrees that became the standard gallon of the different colonies.

LEADING SIDE OF ENGINE.

(73) R. W., Rome, N. Y., writes: What is meant by the expression, the leading side of a locomotive?—A. The term "leading side" refers to the cranks. As the cranks are set 90 degs. apart, that which leads the other is called the leading crank. For instance, with the ordinary locomotive standing with the right hand crank on the front center, the crank on the other side is on the top quarter. As the engine moves forward the left crank follows the right side one at a distance of 90 degs.

TURBINE ENGINES.

(74) Inventor: I have invented a steam turbine engine and wish to have it tried upon a locomotive. Could you obtain the privilege for me?—A. No. We do not wish to have anything to do with such an experiment. There are difficulties about applying a turbine to a locomotive that the ordinary inventor does not realize.

HORSE POWER OF LOCOMOTIVES.

(75) G. W.—The horse power of stationary engines can easily be figured out because the effort transmitted through the piston can easily be converted into so many foot pounds per minute. It is different with a locomotive, for the computation of the power involves com-

plications of leverages and pressures that appear beyond ordinary comprehension. Is there any way of getting at the horse power of a locomotive so that it will mean something?—A. Study the chapter in Sinclair's Locomotive Engine Running, on Traction Power and Train Resistance. It tells all about figuring horse power of locomotives.

DECREASING LEAD.

(76) W. S. L., Childress, Texas, writes: There is a small hoisting engine here which we were repairing. It has a link motion and the lead of the valve decreases as the link is hooked up. In locomotives the lead increases. How is this?—A. In all hoisting engines a decrease of lead as the link is hooked up is an advantage as the engineer can readily stop the engine without closing the throttle valve. In shifting links the lead can be made to increase or decrease according to the manner in which the eccentric rods are coupled on the link. Some forms of valve motion are constant in the amount of lead, as in the case of the Walschaerts valve gear.

WEIGHT ON ENGINE TRUCKS.

(77) E. P. M., Swissvale, Pa., asks: How much of the total weight of a locomotive should be placed on the leading truck of the various types of locomotives? A.—The following are a few examples taken at random from some of the leading railways:

Engine Wheels.	Truck Wheels.	Engine. Total Weight. Lbs.	Weight on Truck. Lbs.
4	2	129,000	46,000
4	4	123,000	42,000
6	2	115,000	17,000
6	4	133,000	30,000
8	2	129,000	12,500
8	4	130,000	33,000
10	2	200,000	26,500

COMPOSITION OF ROD PACKING.

(78) Runner says: I am situated in the backwoods and have to do all my own repairing. I have had difficulty in making rings for rod packing. Could you give me pointers on the subject?—A. The best pointer we can give is buy new rings from the original makers of the packing. The best composition we know of for rod packing is tin, 100 parts; copper, 9 parts; antimony, 6 parts. Melt separately.

Some time ago a northern golfer drove a ball, a fine, low, skimming shot across a river. Just as the ball was nearly over a salmon leaped at the ball and caught it in its mouth. Such was the pace of the ball that it carried the salmon on to the river's bank, where it was immediately secured with the ball tightly wedged in its teeth.—*Golf Illustrated.*



# Air Brake Department

## Buzzing of K Triples.

Whenever an emergency valve leaks in a quick-action triple the defect is made evident by a buzzing sound, accompanied by a blow from the exhaust port of the triple or from the exhaust port of the pressure retainer. Such a defect has the effect of leaking away brake pipe air when brakes are released, and of equalizing brake cylinder, aux-

creasing the instruction with respect to cutting out triples of this type when they "buzz" must be modified or, if not, there is possibility of trainmen and others needlessly cutting them out.

With the K triple and all others of the quick service type, there will be a buzzing sound heard while the reservoirs are charging and recharging, which will grow less distinct as they charge up, and finally will

valve it should be repaired or cut out until such time as repairs can be made.

To determine whether the emergency valve is defective or not, when there is a strong blow at the exhaust port while brakes are released, close the cut-out cock in the cross-over pipe. If the brake applies and the blow ceases it is the emergency valve that is leaking.

The reason for the quick service



RAILROAD LOCATION AMID WOOD AND STREAM, LABELLE, QUÉ.

iliary reservoir and brake pipe pressure when the brakes are applied with a light service reduction, the result in one case being a waste of air, and in the other the accumulation of too much pressure in the brake cylinder, which sometimes is the cause of slid flat wheels.

The remedy for a defect of this nature has been, and is, to remove the defective triple and substitute one in good order, or, if this cannot be done, to cut out the defective valve.

On account of the large number of type K triples that are now in use and because this number is rapidly in-

crease as equalization takes place. It will be seen, therefore, that if a quick service triple buzzes until the auxiliary is charged, and then ceases, it is all right both with respect to its quick service feature and to the condition of the emergency or rubber-seated valve, and, of course, should not be cut out unless defective in some other respect. When there is a blow at the exhaust port of the K triple or at the exhaust port of the pressure retainer while the brakes are released it is an indication of a defect either in the emergency valve or exhaust slide valve. If the triple has a defective emergency

triple buzzing while charging the reservoir is practically the same as that for an ordinary triple when the emergency valve leaks, namely, the rapid filling and emptying of the chamber between the check valve and the emergency valve, which causes the former to vibrate rapidly on its seat.

## Brake Beam Release Springs.

Whenever the brake beam release spring comes up for consideration there is almost invariably quite a diversity of opinion expressed as to their real value in the brake system, but it is

becoming more evident as attention is directed toward them that their importance has been much overestimated.

The function of the brake beam release spring is to carry the beam and shoes away from the wheels after the release of the brakes is made, thus preventing the latter from dragging against the wheels and offering resistance to the free motion of the car. The use of the release spring is confined almost exclusively to passenger equipment, but the question is raised every little while, if freight equipment can be successfully handled without this device to prevent rubbing and dragging of the shoes, why cannot passenger equipment also?

equipment was pretty much what it happened to be and in almost every instance was far below what it should be. The discussion brought out the fact that in many cases a man of average weight and strength could hardly bring the shoes of a passenger coach up against the wheels with the hand brake, and his inability to do this was almost entirely due to the enormous resistance of the release spring.

From this it must be evident that the power of the air brake is much reduced because of the resistance, and hence the margin of safe braking power considerably reduced.

The Air Brake Association at the

#### Incessant Watchfulness with Oil.

A curious incident was mentioned by Mr. W. G. Menzel, S. M. P., of the Wisconsin Central, during the discussion on "lubrication" at the last Master Mechanics' Convention. Said Mr. Menzel, "one of the engineers that had done very well on oil for a long time suddenly fell off, perhaps not suddenly, but gradually fell off. I took the matter up with him and found out the reason for it. He put it this way—he said that he could run an engine just as light on oil as anybody by giving it very close attention, in fact, watching it all the time, but he found that he was giving practically all his attention to the lubricating of the engine in order to make

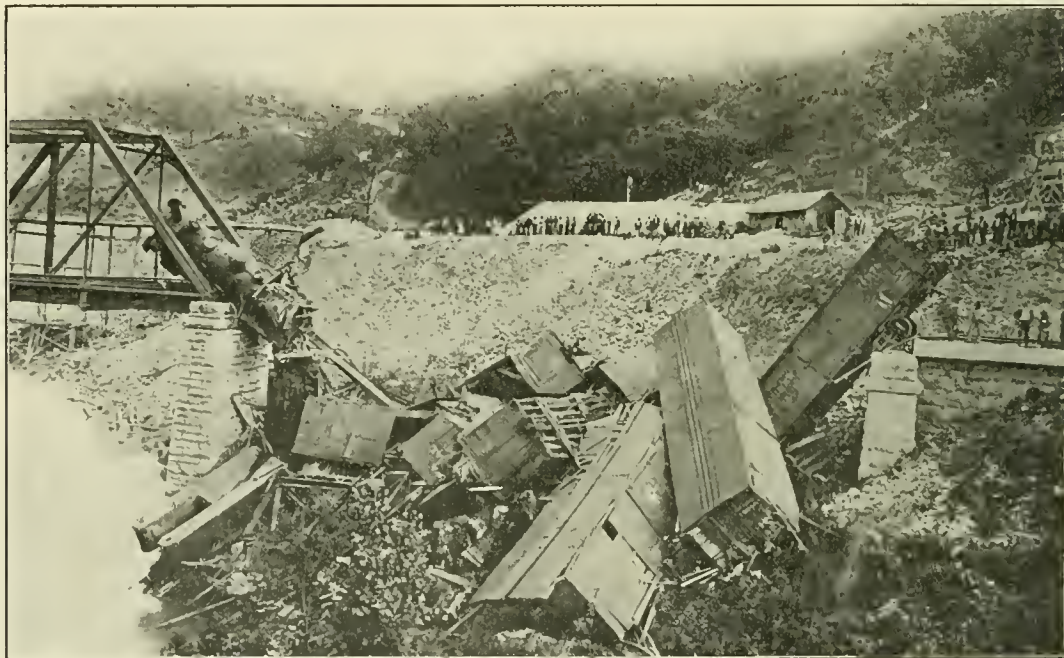

WRECKED BY ACCIDENTAL DISCHARGE OF DYNAMITE WHERE TUNNEL WAS BEING DRIVEN.  
(Courtesy of the Engineering Record.)

In April, 1894, Mr. Waldo H. Marshall presented a paper at the meeting of the Western Railway Club, in which it was shown by actual experiment that there was a material loss in braking power due to the resistance encountered from the brake beam release spring whenever the brakes were applied. That they interfere seriously with the proper adjustment of the brake gear, and make it very difficult to renew brake shoes and adjust slack properly is well known by all who have this work to perform.

On the heavy passenger equipment of to-day it is difficult to design and install an efficient hand brake, and the committee reporting to the late Air Brake Convention on the subject of hand brakes for freight and passenger cars in mountain grade service showed that hand brake power on both kinds of

Columbus Convention appointed a committee to investigate the merits of these springs and report their findings at the next annual convention. We believe that this is a very important work and that the committee will be able to bring sufficient evidence to the attention of air brake men as will be effective in setting on foot a movement to do away with brake beam release springs altogether.

Like some other things which have been used on railway equipment the release spring has been continued in service because it was customary to have them more than for any real use they were to the service. Now that their value in the work of efficient train braking is questioned seriously it is not unlikely that the gradual elimination of this ornamental appendage is to be expected.

an oil record. He said he had made up his mind that he would rather pay a dollar, or perhaps \$1.50, out of his own pocket, and get more oil, and not watch it so closely. He said if we didn't want to let him have the oil he was willing to pay for it rather than to have the extra trouble of watching the oil so closely. I think that is probably the secret of why we are not doing better on oil."

In this connection we have long been aware that many locomotive engineers purchase with their own money a supply of Dixon's graphite to obviate the incessant attention necessary to keep rubbing surfaces from cutting, and this is the direct result of the fact that frequently the amount of lubricant supplied by the railroads is not enough to do the work.

# Electrical Department

## Elementary Principles of Dynamos.— IV.

In an armature with a single coil, such as was shown in Fig. 4 or Fig. 5, the e.m.f. generated under a given set of circumstances is proportional to the total number of turns, and the resistance of the armature winding is also proportional to the total number of turns. With an armature with four or more coils, such as was shown in Fig. 7 or Fig. 9, however, the e.m.f. is proportional to half of the number of turns, and the resistance of the armature winding is only one-fourth of that of the total amount of wire which it contains. This is because the two halves of such an armature are in parallel. In Fig. 7, for instance, if the field poles are directly opposite the coils B B, and the brushes touch the commutator directly opposite, A A, so that each brush touches two bars, and if a north pole is at the left hand side and the armature is revolving clockwise, then, in the position shown in the figure, there will be no e.m.f. generated in the coils A A, and that generated in each of the coils B B will tend to send a current toward the bottom brush. If the circuit between the brushes is closed, current will then flow out of the bottom brush, through the circuit, in at the top brush and will then divide, half going through each of the coils B B and back to the bottom brush.

The e.m.f. generated by the machine at this instant therefore will be that of a single coil B. A little before or a little after this position each of the four coils will be generating and each brush will be touching only one commutator bar. As will be seen by the right hand rule of thumb, forefinger and middle finger, the e.m.f. generated in the two coils on each side of a vertical line through the centre will tend to send a current toward the bottom brush. Current coming in at the top brush will hence divide between these two pairs of coils. The e.m.f. produced by the machine therefore will be one-half of the total generated by the four coils, so that if each coil B has 40 volts generated in it, and each coil A has 10 volts, then the voltage between the brushes of the machine will be 50 volts.

Regarding the armature winding as a part of the path of the total current, it will be seen that the current passes through only one-half the length of the total winding; i.e., through one coil A and one coil B in series and through two such halves in parallel. From the formula

for the combined resistance of two circuits in parallel, it will be seen that the combined resistance of the armature to the total current is thus only one-fourth that of the entire winding, or in this

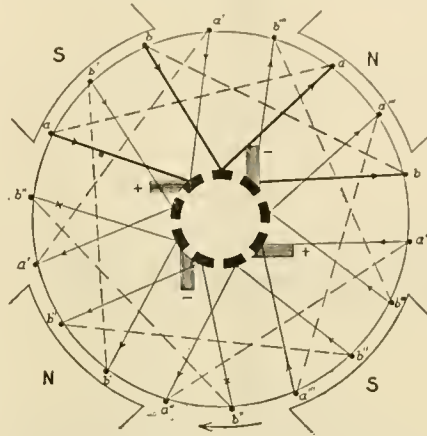

FIG. 17. MULTIPLE WOUND ARMATURE.

case, since there are four coils, it is equal to that of a single coil.

A ring armature such as that shown in Fig. 7 may be used with a field frame of any number of poles, provided a brush to carry off the current generated be located midway between each pair of poles and alternate brushes connected together. A drum wound armature, however, must be wound for the particular number of poles on the field frame with which it is to be used. Where the field

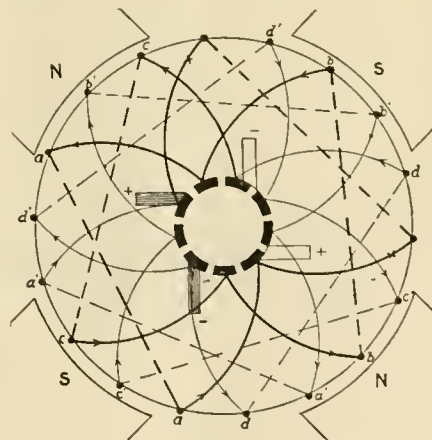

FIG. 18. SERIES WOUND ARMATURE.

frame has more than two poles there are two distinct ways in which an armature may be wound.

Referring to Fig. 16, a wire in passing to the right from A to B will have exactly the same cycle of e.m.f. generated in it as one passing from B to A. If each wire has an e.m.f. of 10 volts gen-

erated in it, and is capable of carrying 100 amperes without injury, then it is evident that we may either connect the two wires in parallel, in which case we will have a machine generating 10 volts and capable of delivering 200 amperes, or we may connect them in series, when we will have a machine generating 20 volts and capable of delivering 100 amperes.

A better idea of just how the connections are made in each case may be had from Figs. 17 and 18, which show a four-pole generator having nine armature coils with the coils connected in parallel in Fig. 17 and in series in Fig. 18. Fig. 19 shows the winding in Fig. 17 as it would appear if cut at one point and spread out flat, and Fig. 20 shows a similar view of the winding in Fig. 18.

It will be seen in Figs. 17 and 19 that with the armature in the position shown there are four sets of coils, in parallel, feeding the brushes, each set consisting of a coil "a a" and a coil "b b" in series. It will also be seen that the e.m.f. between any two adjacent commutator bars is that generated by a single coil "a a" or "b b." There is also one coil, the leads of which are marked "x," which is not generating any e.m.f., since it lies in a position exactly midway between the poles, and is hence not cutting any lines of force. The voltage generated by such a winding is the sum of the voltages of a coil "a a" and a coil "b b," and its current carrying capacity is four times that of a single coil. Such a winding is called a lap, or a multiple winding. When a winding of this sort is used there must be as many brushes to collect the current from the commutator as the machine has poles. Direct current generators wound for 125 or 250 volts, as well as very large machines for all voltages, are ordinarily made with multiple wound armatures.

From Figs. 18 and 20 it will be seen that there are only two groups of coils in parallel feeding the brushes, instead of four, and that each group consists of four coils, "a a," "b b," "c c" and "d d," in series, instead of only two. It will be seen, moreover, that the e.m.f. between adjacent commutator bars is that generated by two coils, "a a" and "b b," or "c c" and "d d" in series, instead of only one coil. As in Figs. 17 and 19 there is one coil, the leads of which are marked x, which is in such a position that no e.m.f. is being generated in it. This idle coil connects the coils "a a," "b b," "c c," "d d" with the commutator bar on which the positive brush rests. The coils "a a," "b b," "c c," "d d" are connected

directly to the commutator. The voltage generated by such a winding is the sum of the voltages of the coils "a,a," "b,b," "c,c" and "d,d." or double that of the winding shown in Figs. 17 and 19. The current carrying capacity, however, is only twice that of a single coil, instead of four times, or only one-half that of

the armature are also rotated so as to cut the lines of force produced by the field magnets, and so an e.m.f. is generated in them in exactly the same way and same direction as if the armature were being driven as a generator by an engine or some other prime mover instead of rotating as a motor due to the

e.m.f. is called the *counter e.m.f.* of the motor. It plays a very important part in the action of the motor.

If the armature of a motor which is standing still is connected to an electric circuit, the current which flows through the windings depends only upon the voltage of the circuit and the resistance of the windings, and is determined by Ohm's law. When a motor with a given resistance is running, however, the current which flows is determined not by the voltage of the circuit alone, but by the *difference between the voltage of the circuit and the counter e.m.f.* Thus, if  $V$  is the voltage of the circuit,  $v$  is the counter e.m.f. and  $R$  the resistance of

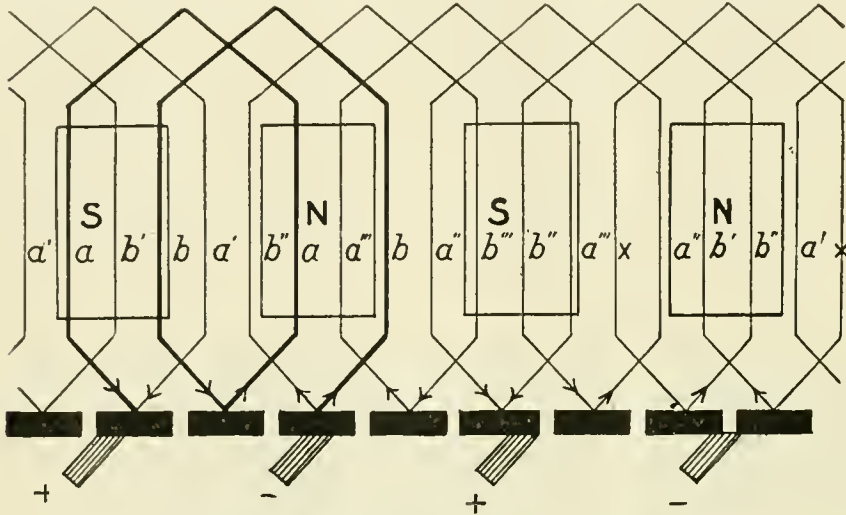

FIG. 19. DEVELOPMENT OF MULTIPLE WOUND ARMATURE.

the winding shown in Figs. 17 and 19. Such a winding is called a *wave*, a *series*, or a *two-circuit* winding. With such a winding there need be only two brushes or sets of brushes, regardless of the number of poles, but additional sets of brushes can be used if desired. For instance, in Figs. 18 and 20 the brushes "A A" are sufficient, but the brushes "B B" could be added if desired. This type of winding is used for small or moderately large generators which are wound for 550 or 600 volts, and is used almost entirely for railway motors.

It is a very simple matter to tell by looking at the armature of any generator whether it has a multiple or a two-circuit winding. If the coils at the front and rear ends both turn in the same direction, as in Fig. 19, the armature is multiple wound; if they turn in opposite directions, as in Fig. 20, the winding is of the two-circuit type.

**Counter Electro-Motive Force.**

An electric motor contains the same essential elements as a generator, and, in fact, the same machine can, as a rule, be used as either a generator or a motor. It has already been explained that when the wires on the armature of a generator are rotated so as to cut the lines of force produced by the field magnets, an e.m.f. is generated in them, and that when the circuit between the brushes is closed this e.m.f. causes a current to flow through it. In such a case the e.m.f. and the current which it produces are in the same direction.

In the case of a motor, the wires on

passage of current through it. It has already been mentioned in another article that the relation between the direction of the rotation, lines of force and current in the armature of a *motor* were those of the thumb, forefinger and middle finger of the *left hand*, while the e.m.f. generated by the rotation of wires in a magnetic field is related to the same

$$\text{the armature, then the current } C = \frac{V-v}{R}$$

or by transposing,  $v = V - CR$ . From Ohm's law we know that  $CR$  is equal to the voltage required to send the current  $C$  through the resistance of the armature, so that it is evident that the counter e.m.f. is the difference between the voltage actually applied to the armature of any motor which is running and that required to send the same current through it if it were standing still.

The power input to the armature of a motor is equal to the product of the voltage at its terminals by the current which is flowing. The product of the voltage required to overcome the resistance of the windings (*i.e.*, to send the same current through the windings with the motor at rest) by the current rep-

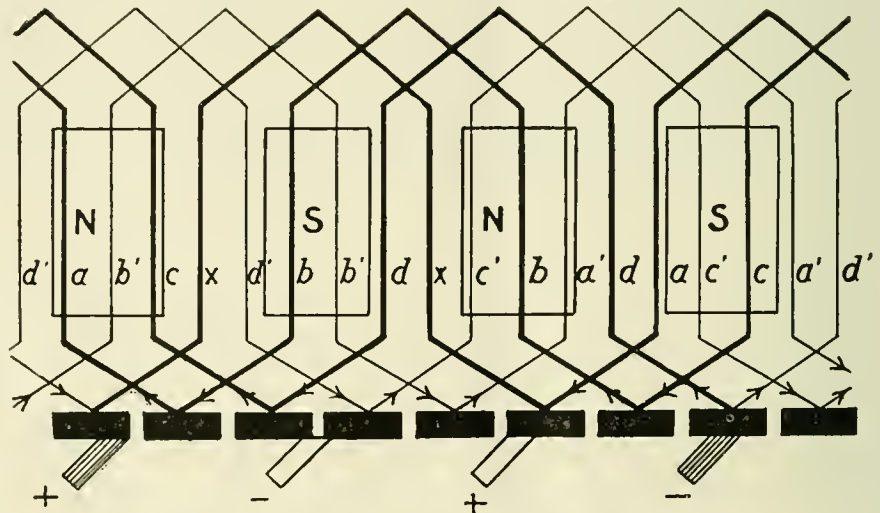

FIG. 20. DEVELOPMENT OF SERIES WOUND ARMATURE.

resents energy lost in the armature. The difference between these two quantities, *i.e.*, the product of the counter e.m.f. by the current, represents the work which the armature is doing by its rotation. The counter e.m.f. of a motor is thus an indication of its output.

The efficiency (*i.e.*, the output divided by the input) of electric motors is usually fairly high, so that the counter e.m.f. of a motor under normal conditions is

quantities as shown by the corresponding fingers of the *right hand*. With the thumbs and forefingers of the right and left hands pointing in the same direction, the middle fingers will be pointing in opposite directions. It will thus be seen that the e.m.f. generated in the armature winding of a motor is in the *opposite* direction to the current which is driving the motor, and tends to prevent its flowing. On this account this

resents energy lost in the armature. The difference between these two quantities, *i.e.*, the product of the counter e.m.f. by the current, represents the work which the armature is doing by its rotation. The counter e.m.f. of a motor is thus an indication of its output.

The efficiency (*i.e.*, the output divided by the input) of electric motors is usually fairly high, so that the counter e.m.f. of a motor under normal conditions is

nearly equal to the voltage at the armature terminals. If a motor is driven as a generator by some outside source of power at the same speed at which it normally runs as a motor, and with the same strength of magnetic field, then the voltage which it generates under these conditions is equal to its counter e.m.f. when running as a motor.

The speed at which an electric motor runs depends upon its counter e.m.f. To drive the armature, either running, idle or coupled to any load, requires a certain torque. With a given magnetic field strength, this torque requires the passage of a certain current through the armature. To force this current against the resistance of the armature requires a certain voltage. When the motor is connected to any circuit, then the armature will run at such a speed that a counter e.m.f. will be generated equal in value to the difference between the voltage at its terminals and the voltage required to force the current against the resistance of the armature windings.

If a motor is running a given speed, and the field magnets are weakened, then the counter e.m.f. of the motor will be weakened. The difference between  $V$  and  $v$  will hence be increased, and since  $R$  remains the same,  $C$ , which equals  $\frac{V-v}{R}$ , will increase. The current, moreover, will increase by a much greater percentage than the field strength is decreased, so that the torque will be increased. (Torque is proportional to the product of field strength and armature current.) Increasing the torque beyond that required for maintaining the former speed will cause the armature to speed up, and it will continue to speed up until the faster speed makes up for the weaker field and raises the counter e.m.f. to its proper value, and the greater current raises the torque to its proper value and with the new field strength, new current value and new speed, a balance is again reached where the counter e.m.f. is just equal to the difference between the voltage of the circuit and the voltage required to force the new current against the resistance of the armature windings.

If the field magnets are strengthened, then the effect is just the opposite. The counter e.m.f. is increased, the difference between  $V$  and  $v$  is decreased, and hence the current is decreased and also the torque. The speed hence falls off until, in spite of the stronger field the counter e.m.f. is reduced on account of the lower speed, and a new balance is reached.

The same general effects can also be produced by changing the voltage  $V$  at the armature terminals instead of changing  $v$ . If this voltage is increased, the speed will be increased, and if it is decreased the speed will be decreased.

Since the counter e.m.f. of a motor

is nearly equal to the voltage of the circuit from which the motor is operated, the voltage required to force the current through the armature, or the *drop*, as it is usually called, must be very small. If the full voltage of the circuit were applied to the armature when it was standing still (and there was hence no counter e.m.f.), a very large current would flow through the windings and probably damage them. Motors must be started, therefore, by applying a voltage much lower than normal at first and gradually raising it as the motor speeds up, until normal voltage is applied to the motor. A convenient way to obtain reduced voltages for starting motors is by connecting an external resistance of such a value in series with the motor at the start that the full voltage of the circuit will just



PREPARING FOR THE HUDSON COMPANIES' TERMINAL IN NEW YORK.

be able to send the desired current through the combined resistance of the armature and the external resistance in series. A resistance of this sort is ordinarily called a *starting box*, or a *motor starting rheostat*. It is divided into a number of steps, so that these can be cut out of circuit one at a time as the motor speeds up and its counter e.m.f. increases.

For regulating the speed of motors by changing the strength of the field magnets, *field rheostats* are used, the same as for regulating the voltage of generators.

A process of welding tubes by heat generated through an oxygen-acetylene blow pipe is coming into use in France and is likely to be applied in this country to small tubes. Acetylene gas seems to be reaching very extended fields and there is decided probability that a combination of alcohol and acetylene gas will produce a cheap fuel that will compete in price with gasolene.

### Electrical Operation on the Erie.

The new electric system of the Erie Railroad between Rochester and Mount Morris, which was described in our May issue, was put into service on Sunday, June 23, and has already proved a great success. At present there is a train about every two hours, which makes the run of 34 miles in one hour and twenty minutes, including the regular station stops. The electric trains have become so popular that although it was originally expected that single cars would be sufficient, three or four car trains are frequently necessary. This line is the first converted steam road to use the single phase electric system in commercial service and the first single phase road in America to use a trolley voltage of eleven thousand, and its official opening for service is an important event in electric railroad operation.

### Hudson Companies' Cars.

Work on the Hudson Companies' tunnels is being pushed ahead with vigor, and the opening of this means of transit between New York and Jersey City will be a great relief to many daily travelers to and fro across the river. The tunnels themselves are strictly tubes, being circular in section and lined with cast iron.

The cars to be used on this subterranean line of railway are somewhat similar to those now used on the New York Subway. The cars are 48 ft. long over buffers, 12 ft. high from rail to top of clearstory roof, and 8 ft. 10½ ins. wide over platforms. The feature which will strike an ordinary passenger is the fact that there are two central doors, one on each side of the car. Each door is 3 ft. 8 ins. wide. The seats are arranged along the sides of the car and they are divided so as to accommodate three and four persons in each division. These divisions of the seat are made by arm rests and partitions, and at the end of each arm rest, from floor to ceiling, there is a rod placed, which it is intended to form a better hold for standing passengers than that afforded by the ordinary overhead strap. These cars are, however, provided with overhead straps.

The under frames of these cars are of steel. The side sills are made of 6 in. channels, and form the bottom chord of a steel truss which forms the side of the car, and in the large central panel of this frame is the side door of the car. The centre sills are 6-in. I-beams. The needle beams are composed of angles with truss rods and turnbuckles. The body bolsters are formed of stiff plates. The top one passes over the members of the underframing and the other passes from the top of the side sills, below the centre sills and up to the top of the side sills again. The end sills have been made very heavy and strong, and shelf angles have been provided below the level

of the end sills for the purpose of carrying the draw gear. Two heavy steel castings are riveted to the centre sills at each end. These rest upon the top of the sills and are carried down and secured to the webs of the I-beams. The castings are solid and heavy and stand up out of the way on each side of the doors. In the

by the closing of the doors, so that the closing of the last open door completes the circuit and the signal lamp burns and thus indicates that all the doors by which passengers may enter and leave the train are shut.

The control equipment is the latest type made by the General Electric Company,

how heat goes up and fog tries to come down. The best heated roundhouse that I ever saw had no modern appliances—simply had a steam coil running the full length of the house. I think there were eight pipes in this coil. There were pits on both sides, in between the series of steam heat coils, a very good sewer in the front. The fog being forced up by the heat from the pit comes in contact with this coil that is above, which dries it out. I was there when it was forty degrees below zero and engines were constantly coming in, doors were being opened all the time, and there was no fog to speak of; but, I might say the house was built with a dividing wall between every five pits. Of course, there should be heat at the top to dry out the moisture that rises. In this same house, you could open a cylinder cock and stand right there and watch the steam go up, but there was little fog left after it had passed a given point. In our larger roundhouses, it is a fact that there is not enough provision made for circulation. I never had an opportunity to look as deeply into the circulation as I have had in the last year.

"I was invited by one of the general superintendents of motive power, to inspect an eighteen stall roundhouse that he had just built, and which he said was modern in every particular. It was equipped with the Sturtevant heater system, and in walking through, I asked him what provision he had made for blowing off the boilers for washout. This had not been provided, for, as the exhaust steam from the boilers was blown right into the pit direct, but after talking with him and giving him an idea of what I thought was right, he saw things as I did, and has since written me that he has



EXCAVATION IN NEW YORK FOR CORTLANDT STREET TERMINAL HUDSON COMPANIES' TUNNELS.

event of accident where the platform of one car was forced up over the other, these anti-telescoping devices are intended to prevent the destruction or injury of the car body.

The doors, both side and vestibule, are made of steel plate. Each door is supported on ball-bearing hangers, which run on a track above the door. The doors are operated by air cylinders. The piston has a stroke of about 15 ins., which, with a rack and pinion, gives the door the necessary travel. The door mechanism is so arranged that the door moves up to the door post, but does not strike against it. The edge of the

and several important improvements have been made in the method of insulation. The motor and trailer trucks are of the M. C. B. type, and were built by the Baldwin Locomotive Works. Each motor car is equipped with two 160-H.P. motors. The first lot of these cars will probably be in readiness in September, and it is likely that the line from Hoboken to New York will be open in November.

**General Foremen's Association.**

**DISCUSSION ON INDIVIDUAL EFFORT.**

In the discussion of this subject which followed, Mr. C. A. Swan said

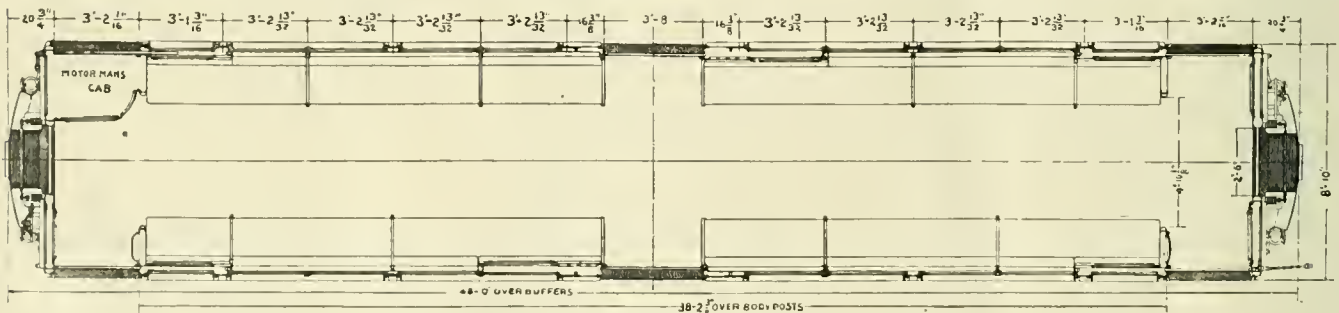

PLAN OF MOTOR COACH FOR HUDSON COMPANIES.

door is shod with rubber hose, which obviates any danger of crushing fingers or hands of passengers if caught between door and post. An electrical signal is provided throughout the train by which the motorman is automatically notified of the fact that all the doors are closed. The signal in the cab consists of a bell and glow lamp, but the connections along this signal circuit are made

on the subject of ventilating roundhouses, "I want to say it is invariably a rule, in case of a steam heated house, especially in cold weather in our northern countries, that when you bring an engine that is covered with snow and ice into the roundhouse, the heat commences to go up and melts the ice and snow, which, as it runs off, and produces rather a dense fog. We all know

equipped the house with pipes according to the plans which I showed him, and he said they are working very successfully. This plan is as follows—there is a large pipe running along the side of the pit fastened to the wall of the pit and protected with a boiler plate to keep springs and other parts of machinery from falling on the pipes. The pipe was connected, as I said, with

a universal joint, and this connects direct to the blow-off cock and the engine is blown from this pipe into the sewer and there is no steam or water in the house. I might add that the sewer has a sump, into which the pipe enters before entering the sewer. This makes a very nice arrangement and

there ought to be more heat of some kind overhead to absorb fog. We have a homemade stack built 6 ft. long x 10 ins. long and about 16 ft. high on every other pit in the roadhouse. That carries away the steam and fog to a certain extent, but still it is not enough, and we found it cooled the house down

around the locomotive when the steam was turned on right up through the smoke jack. He was using an open-ended 1/2-in. pipe. I explained to him that he could use a nozzle which would give him the same draft, and at the same time be a saving on the steam consumption. I recently received a

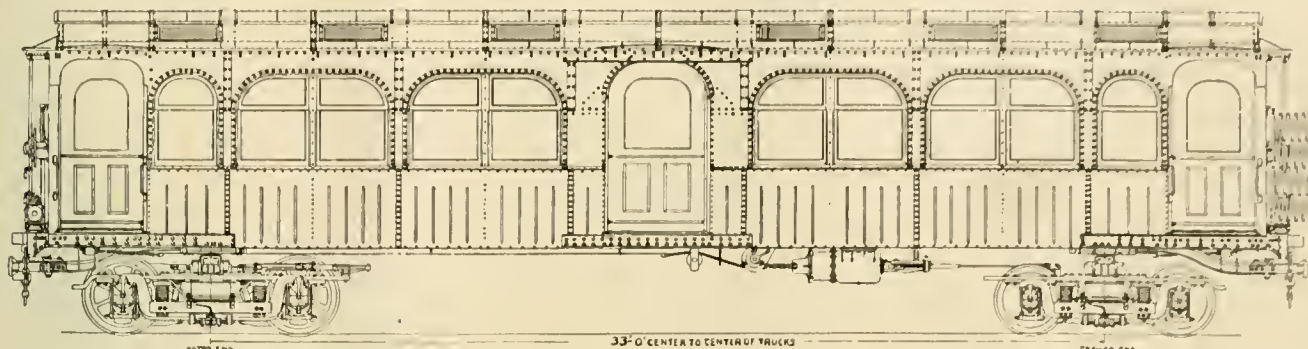

SIDE ELEVATION OF MOTOR COACH FOR THE HUDSON COMPANIES.

keeps the steam out of the roundhouse, and also does away with all noise and protects the men at all times while working around the locomotive."

Mr. Hall said, "I will say that we experienced in our roundhouse as regards heating this last winter, and found the second-hand stationary boiler the best. We would blow the exhaust steam from the engine into this boiler and use the steam from this boiler for the heating apparatus. The water in this boiler was used for washing out locomotives—it furnished hot water for washing out purposes. We live in a very cold part of the country and we manage to keep our roundhouse very warm."

Mr. Bryan said, "There is one thing I don't understand and that is, the method of getting rid of the hot water in blowing out the engine. We don't waste the water at our plant. We blow the hot water and steam right into tanks and use it for washing the boilers out, and it returns to us at about thirty per cent reduction in heat, and of course the waste of water and steam is saved. We are troubled more or less with fog rising over us. An engine comes in covered with snow, and when it begins to melt, there is more or less fog, but this is partly dried out by overhead pipes."

Mr. Beland:—"I may say that the matter of fog is quite a question. I do not think it is a very good idea in heating a roundhouse with steam to have the pipes in the pit, for the reason that when you have a driving spring to put in, and a driving box as well, which might drop down on the pipes and so destroy the heating to a great extent. The pipes ought to be put on the side of the wall covered with some kind of a covering, and I also think

to quite an extent. With engines coming in and going out, especially since our engines have grown in size and our house has not, we find it very hard to keep the house warm at times."

Mr. Swan, continuing the discussion, said, "I visited a roundhouse some time ago and the foreman called my attention to a steam jet which he had placed in the jack. This he used in the place of a blower, which he would have used

letter from him in which he said that he had made the nozzle as I suggested, and that it worked very satisfactorily. This is one of the best devices that I have seen for raising steam on a locomotive, as it does its work fully as well as the blower does, and at the same time is a good thing to keep fog and unnecessary moisture out of the roundhouse. It can be used at any time, whether the locomotive is at the pit



HUDSON COMPANIES' TUNNELS BELOW THE PENNSYLVANIA RAILROAD TERMINAL AT 34TH STREET, NEW YORK.

in the old way. The blower pipe is hung in the stack with a 'U' as we sometimes do. The jet was in the center of the smoke jack and it had the same effect on the fire as the blower used in the stack, and at the same time would take up all the smoke. In fact, it took some of the fog which was

or not. By opening one of the jacks and with the doors closed, the fog would immediately come to this point and is taken up through the jack. I saw it working in very cold weather and it did the work very satisfactorily."

Mr. Fay:—"I traveled over the western parts of the Union Pacific Railroad,

on a portion of the Short Line, also over a portion of the Southern Pacific. At Sparks, Nev., we found a very nearly ideal roundhouse. It is the Southern Pacific terminal. There they had a roundhouse with a double pitch roof, very high, on which there was a lantern affording excellent light. This house was equipped with a rolling steel shutter door which worked very satisfactorily. They had an excellent heating system, steam, and that was worked well. I have often thought since of a system whereby it would be possible to do away with the smoke jack in a roundhouse, and at the same time make it possible to put a traveling electric crane in your roundhouse to handle the heavy work. My idea of the proper ventilation of a roundhouse would be the installation of an exhaust fan with intake pipes on the order of a standard water crane. This would be made of galvanized iron, and have a sliding adjustment parallel to the engine, so that if it became necessary to pinch the en-

could put a forty ton jack anywhere in the place and there would not be the slightest movement of the floor. The house is 120 ft. long and there is lots of room both in front and behind the engines. Their arrangement for lighting and ventilating was the most perfect I have ever seen.

"At another point on the Southern Pacific, they have the finest drop jack, or, more properly termed, drop table I believe in the country. It is the only safe drop table I have ever seen. We are just about to install one at Wyoming on the Union Pacific, and if it is possible to get a copy of these drawings, I will endeavor to have them here at the next convention for you to look at. I have never seen anything exactly like it and know you will all be pleased with the arrangement. This drop table is sufficiently large to accommodate an engine truck. It is in the center section of the floor. It goes down to its maximum depth, can be moved over, then it rises up to the

#### L. & N.-W. Ry. New Tank Engine.

No. 528 is one of the series of new tank engines recently introduced on the London and North-Western Railway from the designs of Mr. G. Whale, the chief mechanical engineer. The engines are of the following dimensions: Cylinders, 19 ins. in diameter, with a stroke of 26 ins.; diameter of radial truck and trailing wheels, 3 ft. 9 ins., and of coupled wheels 6 ft. 3 ins.; center of radial truck to driving wheels, 12 ft.; coupled wheels, 10 ft.; centers of trailing driving and trailing radial wheels, 7 ft. 6 ins.; total 32 ft. 7½ ins.; boiler heating surface; firebox, 161.3 sq. ft.; tubes, 1848.4 sq. ft.; total, 2,009.7 sq. ft.; grate area, 22.4 sq. ft.; working pressure, 175 lbs. per sq. in.; total weight of engine in working order, 74 tons 15 cwt.

#### Past and Future.

In his address at the opening of the fortieth annual convention of the American Railway Master Mechanics' Association, Mr. J. F. Deems, president of the association thus spoke of the pioneers of the association and of the art and science of transportation. He said: "No war-bronzed veterans ever had deeper inspiration or greater cause for self-forgetful devotion than had the pioneers who bore the brunt of the early days of the development which this association has so splendidly advanced. All the honors accorded to military achievement in the past, but illy compare with those which the future will gladly erect to the memory of the men who gave us that grander, that more useful development—transportation—without which to-day the world would be largely a waste. Our predecessors met in a small way and singly the problems which we and those who follow us must meet collectively and in a larger sense, and to solve which it will be necessary to form great combinations that must be harmonious, cohesive and permanent.

"We are fortunate in that our fathers built so well, let us hope that those who follow can truly say the same of us; let us devote ourselves seriously to the problems of to-day; the chief among which is to try to do as well the things that come to our hand as our predecessors did with the smaller things that came to their hands.

"Our own future, and the hope of that larger future which lies beyond, depends on our efforts and our success in providing those who are to help us to-day, and upon whom at no distant day must fall our duties, our opportunities, our honors and our failures."

"If you spread your feelings all over the country, somebody is sure to step on them."—C. M. Alexander.



NEW TANK ENGINE ON THE L. & N.-W. RY.

gine, you would simply pull down the slide. The only difficult thing would be to get the hostlers raise the crane before they moved the engine. No particular damage would be done if they did not. This sliding piece would fall to the ground, and as it would be made of galvanized iron, it would not be an easy matter to repair it if damaged. When this galvanized iron drop was raised to move the engine, it would automatically close that opening through the medium of the cylindrical bearing there. In this connection, by putting another intake pipe midway between the two in the main exhaust pipe, it would be possible to suck all the steam out of your roundhouse, providing you had a fan of sufficient capacity. To my mind, it looks like a feasible proposition. I have never seen it in operation, but cannot see why it would not work to advantage. This roundhouse was the finest I have ever been in. The floor was block paved, the concrete was absolutely solid. You

level of the floor where the truck is removed. It again sinks and comes back to its former position, when it rises, and as it reaches its maximum height, it locks automatically. It is a very fine arrangement. I think those men who have the designing of a roundhouse should pay a little bit more attention to facilities for handling heavy parts. I believe a roundhouse should be so constructed as to permit of the installation of an electric crane for handling heavy material."

#### Stop, Look, Listen.

Circulars and other advertising matter have been reaching this office very frequently of late puffing oil and coal lands as good investments for railroad men. We advise our readers to keep away from investing in such alleged properties. Those having money to invest can obtain sound advice from financial railroad officers of their acquaintance.



# Items of Personal Interest

Mr. G. W. Wildin, until recently assistant superintendent of motive power of the Lehigh Valley, has been appointed mechanical superintendent of the New York, New Haven & Hartford, with headquarters at New Haven, Conn. Mr. Wildin is an excellent example of the younger school of railroad mechanical



GEORGE W. WILDIN.

department men who with a technical education as a foundation have the added equipment of a wide and thorough practical experience in railroad work. At the age of 22 he completed his technical course and entered railway service in 1892. As draughtsman, machinist and locomotive fireman he had several years' experience on the Santa Fé Railroad. At one period he ran a locomotive on the Mexican Central Railway and acted as assistant in the chief engineer's office of the same road. Later on he had charge of the machine shops of the Aer Motor Company, of Chicago, and left there to become locomotive engineer on the Chicago & Alton. Shortly afterwards he was advanced to the position of mechanical engineer of the Plant System. Coming East he accepted the position of mechanical engineer of the Central Railroad of New Jersey. In March, 1904, he was appointed assistant mechanical superintendent of the Erie Railroad, and in April of the same year was appointed mechanical superintendent of the Erie. In January, 1907, he accepted the position of assistant superintendent of motive power of the Lehigh Valley Railroad, which he leaves now to take full charge of

the mechanical department of the New Haven. He enters his new position with the warmest and best wishes of all who know him; he has the rare faculty of being at once head of his department and a friend of those who work under him. Mr. Wildin's career is an illustration of the possibilities that are within reach of the active, earnest railroad man. He is prominently identified with various railway and mechanical associations, and was elected second vice-president of the Master Mechanics' Association at Atlantic City last June.

Mr. Edward F. Leonard, master mechanic of the Maricopa, Phoenix & Salt River Valley Railway, has had his jurisdiction extended to include the Phoenix & Eastern, with office at Phoenix, Ariz.

Mr. W. O. Thompson, division superintendent of motive power of the New York Central at Oswego, for the Rome, Watertown & Ogdensburg, has been appointed master car builder for the western division, on the same road, at Buffalo, N. Y., vice Mr. James Macbeth, deceased.

Mr. J. M. Turner, general manager on the Georgia & Florida Railway, has been appointed purchasing agent of the same road, in addition to being the general manager of that line.

Mr. Leonard Ruhle has been appointed master mechanic on the Colorado & Northwestern Railroad, with office at Boulder, Col.

Mr. H. W. Ridgway, master mechanic on the Colorado & Southern, at Trinidad, Col., has been appointed master mechanic at Denver, Col., on the same road, vice Mr. D. Patterson, resigned.

Mr. William P. Steele has been appointed assistant to the vice-president in the Engineering Department of the American Locomotive Company. Beginning in youth as an engineer on the Boston & Maine, he won his promotion on that road to the position of traveling engineer and inspector of locomotives. From the Boston & Maine he went to Chicago as general traveling railway agent for the Galena Signal Oil Company, of Franklin, Pa., where he traveled over a large territory in the southwest. Mr. Steele has a commanding figure and a frank, genial and yet forceful manner, typical of his self-reliant New England ancestry. The American Locomotive Company have found a good man, and one who is likely to mount still higher on the engineering ladder.

Mr. A. D. MacTier has been appointed assistant to the vice-president on the

Canadian Pacific Railway Company, with office at Montreal, Que.

In the autobiographical sketch for our new book, "The Development of the Locomotive," written by Matthias N. Forney a few months ago, he says of himself: "Perhaps some men and old women who see these notes will be curious to know why no woman was ever asked to share my joys and sorrows. It would not be difficult to give an answer, which would be something like this: 'During the impressionable period of my life I could not afford to assume such partnership. When things went better with me my time was too much occupied to give the matter my attention, and later on, reason of age, attractive women would not smile on me.' It would do no good to admit now that it was a mistake to live alone, but it is also true celibacy has its compensations."

The compensations appear to have been light weight, for we might have been knocked down by a sledge hammer on reading a few days ago among wedding notices: "Mr. Matthias Nace Forney and Mrs. Annie Virginia Spear were married on June 25th, 1907, at the residence of



M. N. FORNEY.

the bride's sister, Mrs. H. A. Elliott, of Baltimore, Md."

We do not grudge our old friend his prospective increase of happiness, but we cannot refrain from thinking that he might have given some hint of the coming change. It was noticed that he was unusually lively at the Atlantic City Conventions in June, but no one imagined that he was enjoying a little matrimonial sunshine in advance.

Mr. Thomas Britt has been appointed acting general fuel agent on the Canadian Pacific Railway, with office at Montreal, Que., vice Mr. A. D. MacTier, promoted.

Mr. J. F. Peters has been appointed principal chief engineer on the Missouri Pacific at St. Louis, Mo.

Mr. W. H. Chambers, assistant master mechanic of the Denver & Rio Grande at Helper, Utah, has been appointed to the new office of master mechanic at Grand Junction, Col., of the Denver & Rio Grande, the Rio Grande Western and the Colorado Midland.

Mr. W. E. Hebard has been appointed engineer of the Buffalo division of the Erie Railroad, with office at Buffalo, N. Y., vice Mr. W. B. Taylor, resigned.

Mr. P. Carroll, division engineer of the St. Louis, Iron Mountain & Southern at De Soto, Mo., has been appointed division engineer on the same road at Little Rock, Ark., vice Mr. J. F. Peters, transferred.

Mr. J. M. Reid, chief engineer of the National Railroad of Mexico, has been appointed chief engineer of construction of the National Lines of Mexico, with office at Mexico, Mex.

Mr. J. L. Kelsey has been appointed inspector of passenger service on the Chicago Great Western Railway, at St. Paul, Minn., vice Mr. N. P. Williams, resigned.

Mr. James E. Sague, of New Hamburg, until recently connected with the American Locomotive Company, has been appointed one of the New York Public Service Commissioners. He was born in Poughkeepsie, N. Y., in 1862, and was educated at the public schools and graduated as a mechanical engineer from

company for six years, and then was made assistant vice-president, and finally first vice-president in charge of engineering and manufacture. He resigned this position on March 1st of this year.

Mr. H. R. Safford, assistant chief engineer of the Illinois Central and of the

with headquarters at St. Thomas, Ont., vice Mr. John Bell, resigned.

Mr. Wm. Baird has been appointed general car inspector of the lines west of the Missouri River on the Chicago, Burlington & Quincy, with office at Lincoln, Neb.

Mr. Joseph Hobson, formerly chief engineer of the Grand Trunk Railway, has been appointed consulting engineer on the same road, with office at Montreal, Que.

Mr. Howard has been appointed chief engineer of the Grand Trunk Railway, with office at Montreal, Que., vice Mr. Joseph Hobson, promoted.

Mr. W. P. Feeley, assistant engineer on the Peoria & Eastern Railway, has resigned to go into other business.

Mr. H. G. Kelly, formerly chief engineer of the Iowa Central and Minneapolis & St. Louis Railway, resigned to become chief engineer in charge of maintenance of way of the Grand Trunk Railway, with headquarters at Montreal.

Mr. Wm. J. Wilgus, vice-president of the New York Central Lines in charge of construction, has resigned, but will not finally sever his connection with the service until October.

Dr. William Freeman Myrick Goss has resigned as dean of the schools of engineering and director of the engineering laboratory, Purdue University, Lafayette, Ind., to become dean of the college of engineering in the University of Illinois, Champaign, Ill.

#### Obituary.

James Macbeth, one of the best known railroad men in New York State, died last month in Buffalo, after a short illness from acute nephritis. Mr.



A BUNCH OF FIVE GOOD ONES AT ATLANTIC CITY.

Yazoo & Mississippi Valley and of the Indianapolis Southern, has been appointed to the new office of chief engineer of maintenance of way of the three companies, with office at Chicago, and the office of assistant chief engineer has been abolished.

Mr. W. S. Kenyon has been appointed master mechanic of the fourth division of the Denver & Rio Grande, with headquarters at Alamosa, Col., vice Mr. G. W. Mudd, resigned.

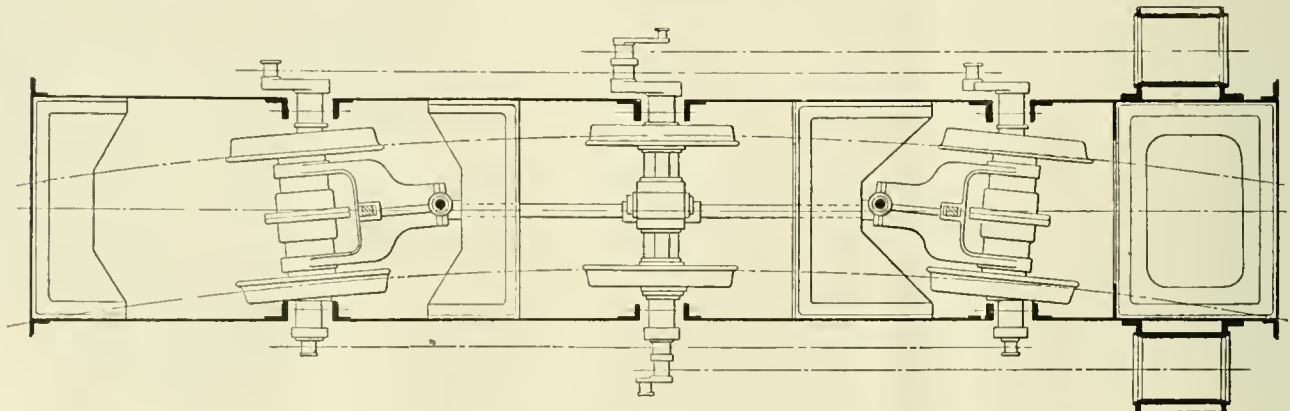

PLAN OF MATHERAN RAILWAY ENGINE, SHOWING SOLID AXLES WITH CRANK PINS, AND HOLLOW SLEEVE BETWEEN WHEELS. RODS REMAIN PARALLEL, WHEELS FOLLOW CURVES.

Stevens Institute of Technology in 1883. He began railroad work on the Chicago, Burlington & Quincy, and afterwards went to the Erie. He spent two years on the Jamaica Railroad in the West Indies and later became connected with the Schenectady Locomotive Works of the American Locomotive Company. He was chief mechanical engineer of this

Mr. Frank S. Flod, having resigned as night round-house foreman of the Lehigh Valley Railroad, at South Easton, Pa., was presented with a handsome gold watch by the engineers and firemen at that point.

Mr. Arthur J. Arnum has been appointed road foreman of engines on the Buffalo division of the Wabash Railway,

Macbeth had just returned from the recent convention of the Master Car Builders' Association at Atlantic City, when he was seized with the illness that terminated fatally. He had held the position of master car builder on the New York Central in Buffalo for the past 15 years. He learned the machinist's trade in Hamilton, Canada,

and won his way upward by a lifetime of hard work. He was foreman machinist at Syracuse and locomotive engineer for several years on the Central. In 1875 he became master mechanic of the Geneva, Ithaca and Sayre Railroad. In 1878 he became Superintendent of Construction of the Elmira, Cortland and Northern. He was also master mechanic of the West Shore at East Buffalo. In 1892 he was appointed master car builder for the Central, which position he held till his death. Mr. Macbeth was prominently identified with public affairs. He was a member of the city council, and had served terms as Civil Service and Park Commissioner. He was President of the Council Board in 1906. He was a native of Aberdeen, Scotland, where he was born in 1846, and emigrated to Canada with his parents in 1855. He was an active member of the Central Railway Club and also a prominent Freeman.

**Locomotives for Matheran Railway.**

The Matheran Railway in India is a small line of 2 ft. gauge constructed



MAIN LINE AND MATHERAN BRANCH COACHES.

up the hillside of a pleasure resort in the near vicinity of the city of Bombay. The railway has a total length of 12 miles, and starts from Neral Station, on the Great Indian Peninsula Railway, 132 feet above the sea level, and rises to the Matheran terminus, 2,495 feet. The maximum grade is 1 in 20, and to work the trains over this line some small tank engines have been supplied by Messrs. Orenstein & Koppel, which are of novel construction. They have six coupled drivers 30 ins. in diameter, which are not connected direct to the axles in the usual way, but are mounted on hollow cylinders or sleeves, through which the driving axles pass, the motion being communicated through ball joints at the centre. The larger of our line illustrations shows the complete arrangement of one of these engines; while the other represents the details of the driving gear and hollow or sleeve axles.

These little engines, when delivered in India, were fitted with the "counter-pressure" retarding device. This brake apparatus, known as the Rigenbach system, is so designed that when the engine is running down grade with the valve gear reversed and the blast pipe closed air is drawn into the cylinders

through the cylinder cocks and pumped into the steam pipe, and so acts as a retarding agent. The pressure is

Boiler—Length of barrel, 7 ft. 10½ ins.; diameter, 3 ft. 2 ins. Heating surface, 452 sq. ft.; grate area of fire

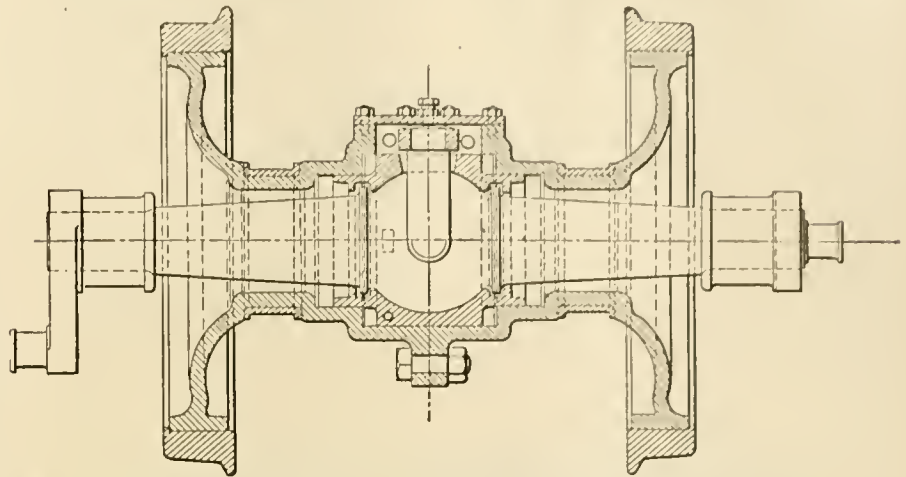

WHEELS WITH HOLLOW SLEEVE CONTAINING SOLID AXLE WITH CENTRAL BALL JOINTS FOR DRIVING; MATHERAN RAILWAY.

regulated by means of a valve in the box, 7 sq. ft.; working pressure, 175 lbs. per sq. in. who can supply water from the tanks to the cylinders to cool them when necessary. This arrangement, we understand, did not work satisfactorily,

regulated by means of a valve in the box, 7 sq. ft.; working pressure, 175 lbs. per sq. in.

**Air Brake Chart.**

We have an air brake chart which is complete in itself and is practically self-explanatory. It forms a quick and concise method of studying the air brake. It is printed in ten colors on good paper, and shows the equipment on engine, tender and train for both passenger and freight service. We have lately secured the copyright of this valuable chart and sell it for fifty cents a copy. The chart is the pictorial method of instruction. It is accurate and easy. Send your orders at once.

**Work for the M. M. Association.**

The Executive Committee of the American Railway Master Mechanics' Associa-

and has since been replaced by the automatic vacuum brake.

The side tanks have a capacity of 450 imperial gallons for water, but this



ENGINE ON THE MATHERAN RAILWAY LEAVING NERAL AT FOOT OF INCLINE.

is not sufficient for the present system of working, and is supplemented by a small tender. The total weight of the engine in working order is 39,000 lbs.

A few of the principal dimensions are as follows: Cylinders—Diameter, 11 13-16 ins.; stroke, 13 13-16 ins.

tion met at Buffalo on July 16 for the purpose of arranging the subjects of interest for the current year, and to select members of the various companies, and to transact other business. There were present Messrs. Wm. McIntosh, H. H. Vaughan, J. H. Clark, Angus Sinclair,

C. A. Seley, F. M. Whyte, John Howard and J. W. Taylor, secretary.

A communication was submitted from the Railway Supply Men's Association requesting the Master Mechanics' Association to recommend that the Traveling Engineers' Association, the General Foremen's Association, the Foreman Blacksmiths' Association and others of similar character be requested to meet immediately after the Car Builders and Master Mechanics finish their conventions so that the members and friends of the smaller associations may enjoy the benefit of seeing the exhibits collected for the benefit of the two larger associations.

The Executive Committee, after discussing the request at some length, decided to do nothing about it at present.

The selecting of subjects and the committees received careful attention and critical consideration. The following is a list of the committees for 1908 and the names of those composing them.

#### MECHANICAL STOKERS.

This committee was continued and the members are now Wm. Garstang, chairman; J. F. Walsh, Geo. S. Hodgins and L. R. Johnson.

#### BLANKS FOR REPORTING WORK ON ENGINES UNDERGOING REPAIRS.

Committee—T. H. Curtis, chairman; C. E. Chambers, E. W. Pratt, T. F. Barton and Henry Bartlett.

#### THE APPRENTICE SYSTEM.

The selecting of a committee to manage this subject was done with a constant view of securing men who had experience with the education of apprentices. Those chosen were G. M. Basford, chairman; C. W. Cross, Pennsylvania Railroad appointee; W. D. Robb, B. P. Flory and John Tonge.

#### PROPER WIDTH OF TRACK ON CURVES.

This committee was continued so that they might collect data about the widening of track on curves. Committee—F. M. Whyte, chairman; W. H. Lewis and F. C. Cleaves.

#### SUPERHEATING.

This committee is expected to report progress. H. H. Vaughan, chairman; Le Grand Parish and R. H. Hawkins.

#### WASHING AND REFILLING BOILERS.

To report on best methods. Committee—H. T. Bentley, chairman; L. H. Turner, M. E. Wells, S. K. Dickerson and H. E. Passmore.

#### HANDLING SCRAP.

Referred to Store Keepers' Association. CASTELLATED NUTS FOR LOCOMOTIVE MACHINERY.

This form of nut growing with favor in certain other lines the committee is requested to have standard dimensions established. Committee—R. B. Kendig, chairman; J. F. De Voy, John Player, G. S. Edmonds and Jno. Mowery.

#### DESIGN AND STRENGTH OF TRUNK AXLES.

Individual paper by L. H. Fry.

#### MALLET COMPOUNDS.

Committee—J. E. Muhlfield, T. Rumney, C. J. Malin, H. Emerson and F. H. Clark.

#### BALANCED COMPOUNDS.

Committee—E. D. Nelson, A. Lovell, S. M. Vauclain, John Howard and S. C. Graham.

#### CAPACITY AND EFFICIENCY OF SAFETY VALVES.

Committee—E. B. Gilbert, H. D. Taylor, J. H. Manning, James Milliken and G. W. Wildin.

#### SUBJECTS.

Committee—C. A. Seley, L. R. Pomeroy and D. F. Crawford.

#### All-Steel Postal Cars.

The Southern Pacific Company's Sacramento shops have just turned out an advanced type of all-steel postal car. There is not a scrap of wood anywhere in the car, except the window frames. In the new car, the main features of the lower framing are two massive 12-in. I-beams that weigh 31½ lbs. per foot. It is mainly due to these beams that the steel car can withstand considerably more shock than an ordinary car with wooden sills can stand. Monolith laid over two courses of corrugated steel forms the floors.

Inside the car is lined with asbestos, while the ceiling, like the outside and the roof, is made of steel plates. In every direction the car is strongly braced, and in order to enable it to stand heavy shocks the end frame has a steel plate 20 ins. wide riveted across the top framing. The whole car is so completely bound together that even if a most severe shock was heavy enough to buckle the entire framing, the car could not be telescoped. Electric lighting and steam heating, automatically regulated, add still further to the fireproof qualities of the car. All the fittings, racks and apparatus used in handling the mails are of steel or brass.

#### Progress Reporter.

The Niles, Bement, Pond Company, of 111 Broadway, New York, have just issued No. 16 of their "Progress Reporter," a high class catalogue published at intervals as interesting new matter accumulates. The new machines and devices which are constantly being brought out by this enterprising company render a publication of their most notable work at once instructive and interesting.

Among the machines illustrated and described in the issue before us, mention might be made of an open turret lathe which has several excellent new

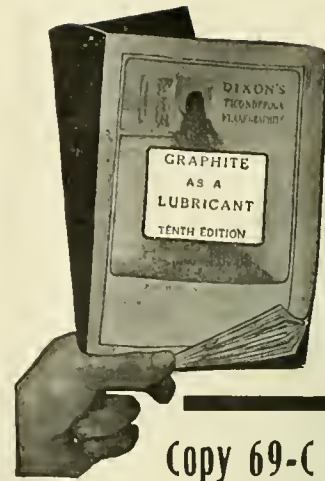

Copy 69-C FREE

Here is a complete and interesting story of graphite and its development as a lubricant. You can not get in any other book of equal size so much information of REAL value. The experience of practical men and the experiments of scientific authorities are both given in this TENTH EDITION of

## "Graphite as a Lubricant"

making it valuable to men of practice and students of theory.

Lubrication in almost every kind of machinery is treated of. "Kinks" and "short-cut" methods discovered and used by resourceful engineers are included.

You should get this book now. Write for FREE copy 69-C.

JOSEPH DIXON  
CRUCIBLE CO.  
Jersey City, N. J.

# GOLD Car Heating and Lighting Co.

Manufacturers of

**ELECTRIC,  
STEAM AND  
HOT WATER  
APPARATUS  
FOR RAILWAY CARS**

**EDISON  
STORAGE  
BATTERY  
FOR RAILWAY CAR  
LIGHTING**

**Largest Manufacturers in the World  
of Car Heating Apparatus**

**Catalogues and Circulars  
cheerfully furnished**

**Main Office, Whitehall Building  
17 BATTERY PLACE  
NEW YORK**

features. Sixteen speed variations leave nothing to be desired in that particular. The gears are very substantial and run constantly in oil. A complete set of turret tools adapted to meet every requirement are furnished with the machine. An hydraulic rail-bender, which may also be used as a riveter, is a fine example of strength and utility, while the double rotary planing machine illustrates the portability of the most ponderous machines. The Pratt and Whitney grinding machines, of which the company are the makers, are the first examples of high class machines which dispense with high skilled labor. Anyone can run these machines, in fact

### Flexible Connections.

In this issue we show in our half-tone illustration the flexible pipe connections for air, steam heat and water supply, as applied between engine and tender, manufactured by the L. J. Bordo Company, of Philadelphia. It is made of standard iron pipe, and so arranged and constructed that it is perfectly flexible and will adjust itself to any oscillation of either engine and tender.

This device has been in use on some of the leading roads for a number of years and has given complete satisfaction. Any master mechanic or engine house foreman will appreciate having



BORDO FLEXIBLE PIPE CONNECTIONS.

they run themselves. The Niles Gantry cranes have also arrived at a high degree of perfection. Those interested should send for a copy of No. 16.

### Steel Passenger Cars for the Pennsy.

The Pennsylvania Railroad Company took the lead in the introduction of steel coal, mineral and freight cars, thousands of which are in use. The indications now are that the same company will lead other railroads in the use of steel passenger train cars. When the Pennsylvania Railroad people take the lead they soon have numerous followers.

The engineers at Altoona, Pa., have been very busy for months working on drawings of all sorts of passenger equipment and now orders have been given out for about 200 steel passenger cars.

a device of this kind, which does away with the annoying delay sometimes occasioned by the renewing a hose that has given away just about the time an engine is made ready for a trip, and engineers on the road are not likely to face the chances of an engine failure at quite so close range as they may without the Bordo connection.

The annual convention of the Traveling Engineers' Association will be held this year in the Auditorium Hotel, Chicago, Ill., from the 3rd of September to the 6th, inclusive. Many interesting papers will be presented, and a large attendance is expected.

If you have not seen our air brake chart it will surprise you. Printed in ten colors. Price fifty cents.

### Improved Band Scroll Saw.

Our illustration shows a band scroll saw of improved type and the manufacturers make a series of comprehensive claims for it. It has a square, upright column, thus enabling the machine to be run at a high speed without vibration. The top wheel is hung solely on a knife edge. The lower wheel has a web instead of spokes, this is advantageous in causing less dust to be fanned about in the shop, and this solid wheel being heavier than the upper wheel, controls the movements of the upper wheel. The machine has a tilting iron table, with improved clamp-

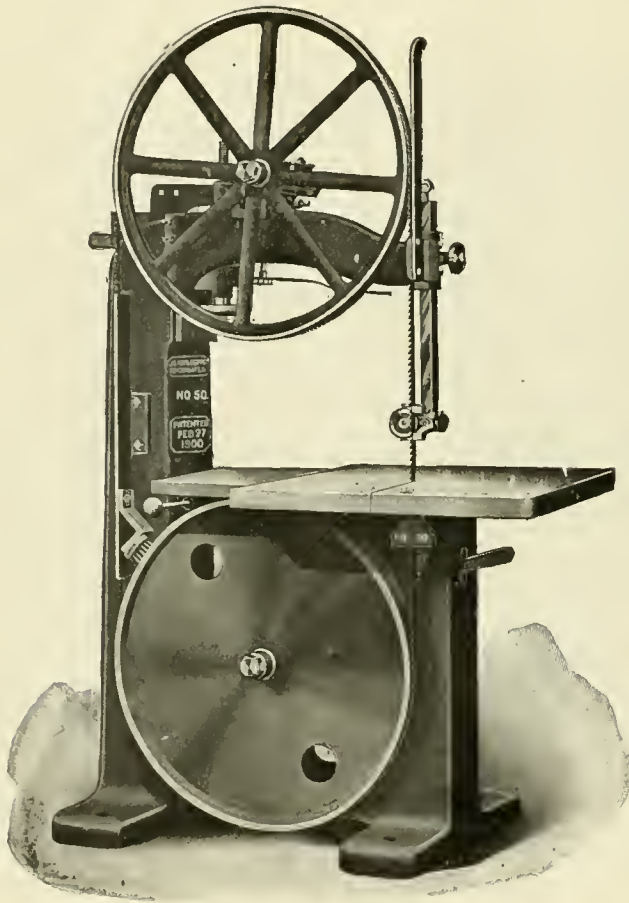

IMPROVED BAND SCROLL SAW.

ing device for clamping it at the desired angle.

Furthermore, this band scroll saw takes 18 ins. under the patent frictionless guide. The guide post is square and fitted for counterweight. The bearings of the wheel shafts are extremely long. Tilting and raising devices for the upper wheel are in easy reach of the operator from the front, and can be used without stopping the machine. The wheels are 36 ins. in diameter and perfectly balanced.

Corner boxes are provided for guide post and these compensate for all wear. The machine is capable of being run at a speed of 650 revolutions per minute.

For further information regarding the tool, write the manufacturers, J. A. Fay & Egan Co., Cincinnati, O.

"Twentieth Century Locomotives" contains more genuine, useful information about the construction and management of locomotives than any book in the market. It is the kind of book that students of locomotive engineering like to keep within easy reach for reading or study. The chapter on Valve Motion itself is worth the price of three dollars charged for the book. It is for sale by the Book Department of RAILWAY AND LOCOMOTIVE ENGINEERING.

The Bliss Electric Car Lighting Company have a very extensive plant situated at Milwaukee, Wis., and they report a steady increase in business. They call attention to the fact that the management of one of our great railway systems not long ago issued orders to prepare to install electric light on its passenger equipment in the next five years, and another great system of railways is constantly adding to its already large number of electrically lighted cars, and several trans-continental lines are electrically lighting their new passenger cars. From these instances they consider the outlook for their business to be bright, to say the least of it.

### Engine Failures.

In presenting an individual paper on locomotive records Mr. W. E. Dunham, master mechanic on the Chicago & North-Western, spoke of the lack of uniformity among railroads in the matter of recording engine failures. He said among other things: "It is natural during a rush period, whether of long or short duration, that engine failures increase in number and often also in proportion to the total miles run in a given period of time. These results may be due to the operating methods and conditions than to any lack of attention on the part of the roundhouse forces. Under these circumstances the

## JUST PUBLISHED The Walschaert Locomotive Valve Gear

By W. W. WOOD.

Nearly 200 pages.

Fully Illustrated.

PRICE \$1.50



The only book issued that is devoted exclusively to the Walschaert Valve Gear, and it fills a demand which, during the last few months, has become very important. If you would thoroughly understand the Walschaert Valve Gear you should possess a copy of this book, as the author takes the plainest form of a steam engine—a stationary engine in the

rough, that will only turn its crank in one direction—and from it builds up—with the reader's help—a modern locomotive equipped with the Walschaert Valve Gear, complete.

The points discussed are clearly illustrated; two large folding plates that show the position of the valves of both inside or outside admission type, as well as the links and other parts of the gear when the crank is at nine different points in its revolution, are especially valuable in making the movement clear. These employ sliding cardboard models which are contained in a pocket in the cover.

The book is divided into four general divisions, as follows: I. Analysis of the gear. II. Designing and erecting the gear. III. Advantages of this gear. IV. Questions and answers relating to the Walschaert Valve Gear, which will be especially valuable to firemen and engineers preparing for an examination for promotion.

Just Issued—1907 Revised and Enlarged Edition.

UP-TO-DATE

## AIR BRAKE CATECHISM

By ROBERT H. BLACKALL.

PRICE \$2.00

The Standard Book on the Air Brake. Contains over 2,000 Questions and Answers giving a detailed description of all the Old Standard and Improved Equipment.

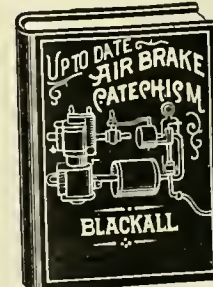

Owing to the many changes and improvements made in the Westinghouse Air Brake it has been found necessary to issue the new, revised 1907 edition of the Air Brake Catechism, which contains all the latest information necessary for a railroad man to pass his

examination on the new as well as the older style of brake.

The new revised 1907 edition is right up to date and covers fully and in detail the Schedule E. T. Locomotive Brake Equipment, H-5 Brake Valve, SF Brake Valve (Independent), SF Governor Distributing Valve, B-4 Feed Valve, B-3 Reducing Valve, Safety Valve, K Triple Valve (Quick-Service) Compound Pump.

Send for a special circular of these books as well as our Other Railroad Books.

Copies of these books sent prepaid on receipt of price.

Agents Wanted Write for our special terms. You can make equal to a month's pay selling our books on the side.

The Norman W. Henley Publishing Co.

132 Nassau St., New York, U. S. A.



**RUBEROID ROOFING**

FOR  
**CARS SHOPS**  
**CABS ROUND HOUSES**

Contains no tar. Will not melt, rot, crack or corrode.  
 Not affected by extremes of temperature. Highly fire resisting.

Spark-Proof Cinder-Proof  
 Gas-Proof Weather-Proof

Write for samples and prices.  
**THE STANDARD PAINT CO**  
 100 William St., New York.  
 Boston, Chicago, St. Louis, Kansas City, Philadelphia, Atlanta.

**Ball's Official R.R. Standard Watches**

16 AND 18 SIZE



17 and 21 Ruby Jewels, Sapphire Pallets

Ball's Improved Safety Double Roller

Are without question the finest watches that American talent and skilled labor can produce, and they are giving such universal satisfaction that we have no hesitancy in claiming that they are the best and safest railroad watch on the market. Tests severe and numerous have proven this fact to be the most critical users in all sections of the country, to which thousands of good Railroad and Brotherhood men are ready to certify.

We have an authorized agent in nearly every railroad center. Call on him for information and facts. Write us for descriptive matter

**The Webb C. Ball Watch Co.**  
 Watch Manufacturers  
 Ball Building, Cleveland, Ohio, U.S.A.

**Patents.**

**GEO. P. WHITTLESEY**

McGILL BUILDING WASHINGTON, D. C.  
 Terms Reasonable Pamphlet Sent

division as a whole should stand the results, instead of the motive power department only being charged with a failure.

There exists at the present time on American railways no uniform method of recording engine failures. This is due to several causes, chief among which is the fact that what would be considered as an engine failure on one road would not be on another. A complete file of what constitutes engine failures would contain as many definitions, almost, as there are railroads. Any set of rules for making engine failure records should be lenient, in a measure, to both the mechanical and transportation branches of the operating department. Reasonable leeway should be given on both sides. Experience is the best guide as to how much this leeway should be, and experience also is the best guide as to what an engine should be charged with."

**Intellectual Blindness.**

Cicero, the Roman orator, exclaimed in a fine burst of self-reproach: *Me Caccum! qui haec ante non viderim.* Blind that that I am!—not to have seen all this before. The only excuse for intellectual blindness is that it is unconscious of its own defects. The world of information that is lying outside of our limited knowledge is vast and literally beyond complete possession by any human mind. A knowledge of our calling, whatever it may be, is indispensable, and an approach to anything like a perfect knowledge is impossible without the aid of books. This is particularly true of the constantly widening domain of the mechanical appliances used on railways.

Among the aids which we can recommend to our readers are the following books:

"Machine Shop Arithmetic," Colvin and Cheney. This is a book that no person engaged in mechanical occupations can afford to do without. Enables any workman to figure out all the shop and machine problems which are so puzzling for want of a little knowledge. We sell it for 50 cents.

"Firing Locomotives," Sinclair. Treats in an easy way the principles of combustion. While treating on the chemistry of heat and combustion, it is easily understood by every intelligent fireman. The price is 50 cents.

"Skeevers' Object Lessons," Hill. A collection of the famous object lesson stories which appeared in this paper several years ago. They are interesting, laughable, and, best of all, they are of practical value to-day. \$1.

"Standard Train Rules." This is the code of train rules prepared by the

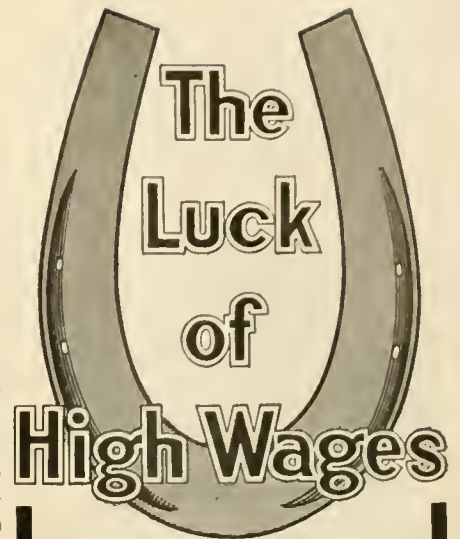

The luck of high wages is spelled with a capital P—it's P-l-u-c-k—the ability to find a practical, easy, and systematic way to secure a better position and increased earnings and the pluck to follow out that way persistently.

In this way John L. Walters, a fireman living at 822 Atchison St., Columbus, Ohio, followed the I. C. S. plan of securing a better position, and is now a locomotive engineer and has increased his earnings from \$65 to \$135 per month.

In this way Harvey Brake-man, a carpenter, of New Kensington, Pa., became an architect and increased his income from \$2.25 a day to \$5,000 a year.

In the same way YOU can increase your earnings, secure a better position and success in the easiest, most practical, quickest, and cheapest way in the world. All we ask for you to write us and allow our experts to tell how we can adapt our system, which in 15 years has bettered the positions and earnings of hundreds of thousands of men, to your own personal needs, no matter how scant your time, money, or education may be. To secure this valuable advice free, it is only necessary to send us the coupon below. Isn't a higher position worth a postage stamp to you?

**INTERNATIONAL CORRESPONDENCE SCHOOLS**  
 Box 805, Scranton, Pa.

Please explain, without further obligation on my part, how I can qualify for a larger salary and advancement to the position before which I have marked X.

General Foreman	R. R. Con. Engineer
R. R. Shop Foreman	Civil Engineer
R. R. Trav. Engineer	Bridge Engineer
R. R. Trav. Fireman	Chemist
Locomotive Engineer	Mining Engineer
Air-Brake Instructor	Architect
Air-Brake Inspector	Bookkeeper
Air-Brake Repairman	Stenographer
Mechanical Engineer	Ad. Writer
Mechanical Draftsman	French } With
Machine Designer	German } Edison
Electrical Engineer	Spanish } Phonograph

Name \_\_\_\_\_

Employed by \_\_\_\_\_ R. R. \_\_\_\_\_

St. & No. \_\_\_\_\_

City \_\_\_\_\_ State \_\_\_\_\_

# Tate Flexible Staybolt

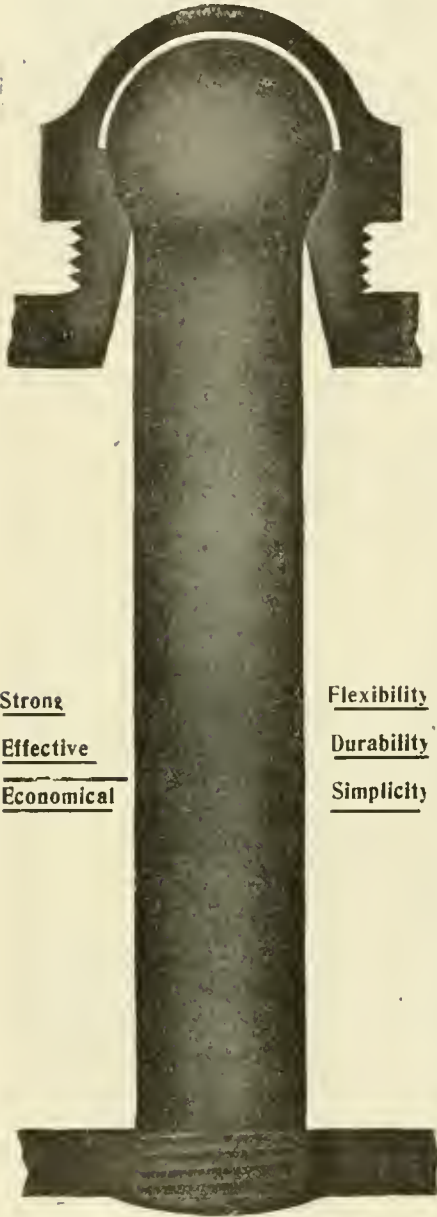

Strong

Effective

Economical

Flexibility

Durability

Simplicity

Holds firebox sheets securely together, and accommodates itself to the unequal expansion of the plates.

## FLANNERY BOLT COMPANY

PITTSBURG, PA., U. S. A.

Suite 308, Frick Bldg.

B. E. D. STAFFORD, - - General Manager  
Write us for Reference Book

American Railway Association for the operating of all trains on single or double track. Used by nearly all railroads. Study of this book would prevent many collisions. Price 50 cents.

"Mechanical Engineers' Pocketbook," Kent. This book contains 1,100 pages, 6x3 $\frac{1}{4}$  ins., of closely printed minion type, containing mechanical engineering matter. It ought to be in the bookcase of every engineer who takes an interest in engineering questions. We use it constantly as a reference for questions sent to us to be answered. Full of tables and illustrations. Morocco leather, \$5.00.

"Locomotive, Simple, Compound and Electric," Regan. An excellent book for people interested in any kind of locomotive. It will be found particularly useful to men handling or repairing real compound locomotives. It is the real locomotive up to date. \$2.50.

"Simple Lessons in Drawing for the Shop," by O. H. Reynolds. This book was prepared for people trying to acquire the art of mechanical drawing without a teacher. The book takes the place of a teacher, and has helped many young men to move from the shop to the drawing office. 50 cents.

"Locomotive Running Repairs," by L. C. Hitchcock. This book contains directions given to machinists by the foreman of a railroad repair shop. It tells how to set valves, set up shoes and wedges, fit guides, care for piston packing, and, in fact, perform all kinds of work that need a thoughtful head and skilful hands. 50 cents.

"Care and Management of Locomotive Boilers," Raps. This is a book that ought to be in the hands of every person who is in any way interested in keeping boilers in safe working order. Written by a foreman boilermaker. Also contains several chapters on oil-burning locomotives. 50 cents.

"Locomotive Link Motion," Halsey. Any person who gives a little study to this book ceases to find link motion a puzzle. Explains about valves and valve motion in plain language. Price \$1.00.

RAILWAY AND LOCOMOTIVE ENGINEERING is a practical journal of railway motive power and rolling stock, and it is so not only in name but in reality. By reading it you get a knowledge of what others think and do. \$2.00 per year; bound volumes; \$3.00.

### The Bettendorf Truck.

The Bettendorf Axle Company, Davenport, Iowa, have issued a finely illustrated catalogue of 64 pages, showing in detail their marked improvements in the manufacture of trucks, bolsters, underframes and railway specialties generally. Probably their most marked specialty is that known as the Betten-

A practical demonstration of the advantages of the **BLISS SYSTEM** of **ELECTRIC CAR LIGHTING** will be given at **ATLANTIC CITY**

During Convention Week (June 12th to 19th) we shall be glad to have all interested in the subject of electric car lighting visit our exhibit on the Steel Pier—Spaces 1,201 to 1,207, inclusive. We shall have there complete Bliss car lighting equipments operating under actual service conditions.

Each separate part of our equipments will also be exhibited in detail, affording railroad men an opportunity to acquaint themselves with the construction and operation of the best system of axle lighting yet devised.

The following representatives of our Company will be on hand to welcome visitors and to explain to them the operation of the Bliss System:

W. L. BLISS,  
JOHN L. BLISS,  
COL. JNO. T. DICKINSON,  
WM. L. LALOR,  
ROBERT C. SCHALL,  
F. URBAN,  
E. B. H. TOWER, JR.

**Bliss Electric Car Lighting Co.**

Main Office and Works, MILWAUKEE

New York Office:  
NIGHT AND DAY BANK BLDG.

Chicago Office:  
MONADNOCK BLOCK.

*Those who are not going to the Convention should send for a copy of our Bulletin 30, which is the next best way of becoming acquainted with the merits of the Bliss System.*



## Locomotive Blow-Off Plug Valves

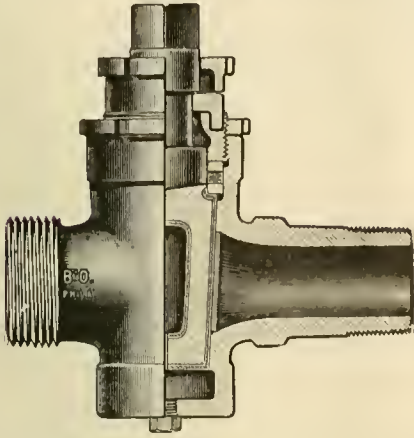

All Brass, extra heavy, with Cased Plug.  
For 250 lbs. pressure.  
Made with Draining Plug to prevent freezing.

dorf truck. Its chief merit lies in the fact that it is free from bolts, nuts and other loosening parts. The truck frames are made of basic open hearth steel, and the journal boxes are cast integral with the frame. Perfect alignment of the bearings is maintained, and the method of changing wheels, which is done with much greater facility than with the old-fashioned system of frame bolting, is fully described with accompanying illustrations, and it is well worthy of the attention of practical railway men.

In the manufacture of truck and body bolsters the company have earned an enviable reputation by the excellence of their work. The operation of tapering the ends of the beams without heating the metal is an admirable test of the quality of the open hearth steel, of which the beams are formed. Inferior stock could not be used in such a test. The same remarks might well be applied to their work in tank car underframes and center sill ends, all of which are fully described in their catalogue, copies of which may be had by applying to the company.

## LOCOMOTIVE GAUGE COCKS

For High Pressure



Bordo Self-Closing Gauge Cocks, made with renewable Hard Bronze seat and disc. Opened and closed with a quarter turn. Guaranteed Steam tight under the most exacting conditions. Shanks Threaded to specifications for Locomotives.

Seats and discs replaced under pressure.

### Need for Intelligent Work.

In his address at the June Convention of the M. C. B. Association President Fowler referred to the report of the Committee on Subjects for the convention of 1908, which recommended the general topic of "Better and More Economical Service of Freight Cars." The presiding officer said he considered that the most important factor in this problem was the question of economical maintenance. Continuing he remarked: "Too little consideration has been given to this matter in the past, freight car repair yards have been located in inconvenient, out-of-the-way places, repair tracks have been set too close together for convenience, the equipment for repairs, both animate and inanimate, has not been of the best, and the consequence has been that cars which should have been returned to service promptly, and with repairs properly made, have been held out of service longer than was necessary and were not properly repaired. Never before has there been such pressing necessity for intelligent work, for proper tool equipment, and for shelter for the men employed, than at the present time.

Railroads all over this continent have, during the past year, been confronted with a demand for cars which it has been impossible to satisfy, and it would have been still impossible if all of the cars held out of service on account of being in bad order had been repaired promptly and put into service; the held-out-cars would, however, have

## Swing-Joints and Pipe Attachment



May be applied between Locomotive and Tender.  
These Swing-Joints are suitable for Steam, Gas, Air, Water or Oil.

Complete Booklet on Application

**L. J. BORDO CO.**  
PHILADELPHIA, PA.

## Homestead Valves

Straightway, Three-way and Four-way,  
and

## Homestead Locking Cocks

Are Famous the World Over

They cost more, but are worth very much more than other makes. You try them and see.



Brass, 1 1/4 in.

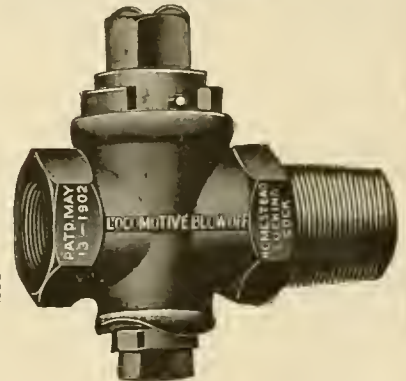

Iron Body, Brass Plug, 1 1/4 in.

**HOMESTEAD VALVE MFG. CO.**

WORKS:  
HOMESTEAD, PA.      PITTSBURG, PA.

## American Locomotive Sander Company

13th & Willow Sts., Philadelphia, Pa.

Proprietors and Manufacturers

LEACH, SHERRURNE, DEAN,      SANDERS  
HOUSTON, "SHE" and CURTIS

**THE ROBERT W. HUNT & CO.**

Bureau of Inspection, Tests and Consultation.  
1137 THE ROOKERY, CHICAGO.

66 Broadway, New York.  
Park Building, Pittsburg.  
31 Norfolk House, London, Eng.  
Inspection of Steel Rails, Splice Bars, Railroad Cars, Wheels, Axles, etc. CHEMICAL LABORATORY—Analysis of Ores, Iron, Steel, Oils, Water, etc. PHYSICAL LABORATORY—Test of Metals, Drop and Pulling Test of Compliers, Draw Bars, etc.

Efficiency Tests of Boilers, Engines and Locomotives.

# One Year and Eleven Months' SERVICE

WITHOUT REPACKING. ON

## High-Pressure Locomotives

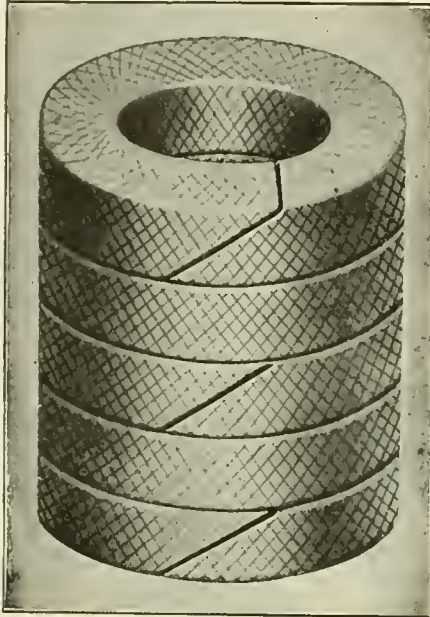

Style 300 TV.

A throttle failure is an absolute impossibility where Crandall's Throttle Valve packing is used.

IT WILL NOT BLOW OUT

## Crandall Packing Co.

FACTORY AND GENERAL OFFICE  
PALMYRA, - - NEW YORK

BRANCHES

New York  
136 Liberty St.

Cleveland  
9 So. Water St.

Chicago  
52 West Washington St.

## Directory of Railways of the World

The Universal Directory of Railway Officials, published in London, contains a list of the entire railroads of the world, with physical particulars and names of all officials.

Send Your Order Now

for the 1907 edition.

Price \$4.00 Prepaid

**A. FENTON WALKER**

Sole Representative for U. S.

143 Liberty St. New York

helped very materially, and would have stopped criticisms made by persons without any real understanding of the situation. It is a reflection on good judgment when vehicles are held out of service for which there is a paying demand at the time, and it would appear that with the attention now concentrated upon the railroads that your best efforts are not desirable, but are absolutely necessary for a betterment of the conditions I have referred to."

Other important subjects for next year's convention, were freight car pooling; the effect of hump yards on freight car damage, problems in steel car construction and the ventilation of passenger cars.

There is a little pamphlet recently issued by the McConway & Torley Company of Pittsburgh, Pa., called the Car Repairman's Guide. It contains a lot of useful information for the man who makes the repairs, or in other words for the person actually doing the work. It applies, of course, to the McConway & Torley couplers, etc., and it is intended to be of use in making out requisitions for material. The suggestion is made that material required for any style of equipment be ordered from the manufacturers of that equipment, because as a rule there is more or less trouble where the attempt is made to use material which is not entirely suitable, so as to save time, and which may result in delay later on. The repairman's guide gives full details of the Janney, Kelso, and Pitt couplers, and of the Buhoup 3-stem equipment, and knuckles, locks, pins, springs, etc., etc., are all illustrated and numbered for ordering, and brief descriptions are given. Send to the company direct if you would like to have a copy.

### Hot Feed Water.

Mr. M. E. Wells, assistant master mechanic on the Wheeling & Lake Erie, when presenting an individual paper on cause of leaks in boiler tubes, at the recent master mechanics' convention, among other things, took up the question of locomotive feed water, and recommended the use of warm water. He said: "I believe the members of this Association should be bending their energies along the line of changing the method of feeding, or using warmer water with which to feed their locomotive boilers. If the temperature of the water entering boilers could be raised to a temperature corresponding to the maximum steam pressure, or if it could be heated to this same temperature entering, but before being liberated in the boiler proper, boiler troubles would be wonderfully reduced."

## The Twentieth Century Master Mechanic

Won't use Solid Mandrels.

Cost too much, take up too much room and don't give satisfaction.

## Nicholson Expanding Mandrels

Take everything from 1 to 7 inch holes. Take up little room—always ready and you can buy four sets for the cost of one of the solid kind.

## Are You Using Them?

Catalogue tells you more about them.

**W. H. Nicholson & Co.**  
Wilkesbarre, Pa.

### Fifth Edition, Revised and Enlarged

Number of pages increased from 617 to 946, and figures from 309 to 494.

Price, \$3.50

# LOCOMOTIVES: SIMPLE, COMPOUND, AND ELECTRIC

By H. C. REAGAN, Electrical Engineer

Send for  
Descriptive Circular

**JOHN WILEY & SONS**  
43 and 45 E. 19th St.  
NEW YORK CITY

# Railroad Men's Catechism

By ANGUS SINCLAIR.

This is a convenient book for the pocket.

Contains 200 pages of Railroad Knowledge.

Prepared Expressly to Help Train Men To Pass Examinations.

Condensed from Books that have Helped Thousands of Train Men to Promotion.

Got up in simple style of Questions and Answers that Any Man Can Understand.

**RAILWAY & LOCOMOTIVE ENGINEERING,**

ELECTRICAL EXCHANGE BUILDING, LIBERTY STREET, NEW YORK.

### Handy Appliance, Handy.

In one of the musical operas last winter a very popular song was, "I want what I want when I want it," and the natural desire of everybody thus voiced in song, to have a handy thing, handy, has been well looked after as far as fire protection in shops and factories is concerned, by the Waggoner Sanatory Fire Bucket Company of Chicago, Ill. The way they give you what you want is by providing a sealed bucket of water which will not freeze, or become foul or dry up. They are fully alive to the fact that water is what you throw on an incipient fire and that an empty bucket is not a substi-



FIRE BUCKET WITH LID.

tute. They say that the bucket is a simple contrivance, and few will dispute this claim. They also say that the solution in the bucket will not evaporate, and that owing to its composition and from the fact that the bucket is covered, the contents will not stagnate, it is therefore clean and sanatory. Each bucket contains, they tell us, three gallons of a solution in which there is no acid, or anything that will injure a person or damage material. When the full bucket of this liquid is hung up in a shop it just waits there for a fire to break out. If no fire breaks out everyone is satisfied, but where the bucket is not interfered with it is always ready, and buckets can do no more. If you want more information on the subject you can get it when you want it by applying to the Waggoner Company, 405 Fisher Building, Chicago. They have issued a folder covering the subject as their lid covers the bucket—completely.

The Independent Pneumatic Tool Company of Chicago report that their business since the first of this year has shown a remarkable increase over the corresponding period last year. They have greatly enlarged the plant at Aurora, Ill., recently installing a large

### THE TANITE CO. seeks the support of Railroaders because!

The man who uses a TANITE wheel will find it safe. Because pay for a TANITE wheel secures the greatest productive capacity. Because TANITE MILLS EMERY is mined in America and appeals to all who earn wages in America. Because TANITE grinding machines are practical.

THE TANITE CO. sells Emery, Solid Emery Wheels, Buffing Lathes, Guide Bar Grinders, Car Brass Grinders, Bench and Column Grinders, Surfacing Machines, Open Side Emery Planers, Saw Gummers, Automatic Planer Knife Grinders, Diamond Tools, Polishing Paste for Brass and Nickel, Emery Wheel Cutters and Dressers.

*The Tanite Co. builds special machines for special wants*

**THE TANITE CO. STROUDSBURG, PA.**

## THE UNION SWITCH & SIGNAL COMPANY

CONSULTING AND MANUFACTURING SIGNAL ENGINEERS

Automatic Block Signals—Electric and Electro-Pneumatic  
Interlocking — Electric, Electro-Pneumatic and Mechanical  
Electric Train Staff Apparatus

General Offices and Works at.  
**SWISSVALE, PA.**

DISTRICT OFFICES:

NEW YORK - - 143 Liberty Street  
CHICAGO - - - Monadnock Block  
ST. LOUIS - - - Frisco Building

## Oliver Lippincott Photographer

20 John Street, New York

Process and Mechanical Prints

Perfect reproduction from Tracings, Black Lines, White Paper, any size, for Specifications and Estimates.

**STANDARD MECHANICAL BOOKS  
FOR ROAD AND SHOP MEN  
BY CHAS. McSHANE.**

**The Locomotive Up to Date**  
Price, \$2.50

**New York and  
Westinghouse Air Brakes**  
Price, \$1.50

**One Thousand Pointers for  
Machinists and Engineers**  
Price, \$1.50

All books bound in fine cloth.

AGENTS WANTED everywhere; write for terms and descriptive circulars. Will be sent prepaid to any address upon receipt of price.

**GRIFFIN & WINTERS**  
171 La Salle Street, CHICAGO

# TOOL STEEL

**Die Blocks  
Steel Forgings**

First Prize awarded at the Louisiana Purchase Exposition, at St. Louis, for our TOOL STEEL when placed in competition with the best makes in England and Germany.

Write for information and Prices. Specify McInnes Tool Steel when ordering.

**McINNES  
STEEL CO.**  
CORY, PA.

amount of new machinery, and increasing thus their output about 50 per cent in order to keep pace with the demand for "Thor" pneumatic tools and appliances. The enlarged plant is in full operation day and night, and they have sufficient orders on hand to keep it running for several months. This company reports that before the end of the year they expect to double their manufacturing facilities.

There is a very useful card calendar for June, July, August and September, which has just been issued by the Storrs Mica Company of Owego, N. Y., and one of them came to our office a few days ago. The calendar gives the days of the month of course, but opposite certain days there are certain useful bits of information concerning railroad club meetings and other associations connected with railroad work. For instance, the International Railroad Master Blacksmiths' Association meets in Montreal, Can. The calendar is useful for those who want to keep track of meetings and conventions like these. On all of the days specified in the calendar and those not included, both this year and following, it is all right to use the "Never Break" mica chimneys for headlights, cabooses, coach, and station lamps. Mica lantern globes are economical and efficient. Drop a card to the Storrs Company if you want a calendar or a mica chimney.

### CONTENTS.

*Early Wooden Bridges.....	349
Rail Motor Cars.....	350
*Cyril Scores a Point. By T. Toot.....	352
Mono-Rail Transit.....	354
*40-Ton Well Wagon. Gt. North. of Eng.....	355
*Gyrostad and Mono-Rail.....	360
Book Notice (Railroad Men's Catechism).....	367
*Hudson Companies Car.....	377
Master Mechanics Committees.....	383
Our Air Brake Chart.....	383
*Flexible Connections.....	385
*Improved Band Scroll Saw.....	386
Engine Failures.....	386
Need for Intelligent Work.....	388
*Handy Appliance.....	391

#### DEPARTMENTS:

*Patent Office.....	351
*Air Brake.....	373
*Correspondence School.....	369
*General Correspondence.....	357
*Electrical.....	375
General Foremen's Association.....	362
Questions Answered.....	371
Personals.....	381

#### LOCOMOTIVES:

*Prairie Type for the Soo Line.....	353
*Siamese and Westphalians.....	356
*Heavy 2-8-0 for the Central of Georgia.....	368
*New Tank on the L. & N. W. Ry.....	380
*Matheran Railway (Flexible Axle).....	383

#### EDITORIALS:

Infraction of Rules.....	364
Driving Shoes and Wedges.....	364
Educating Apprentices.....	365
Inconclusive Tests.....	366
The Railway Service.....	366
Bursting Flue.....	367
Composition of Rails.....	367
Instruction of Firemen.....	367

*Perfect*

Why pay more for a Car and Locomotive Cleaner, when the "PERFECT" will do the work and better at 48 cents per gallon, f. o. b. Philadelphia or Chicago?

THE MODOC SOAP CO.  
228 North Fourth Street  
PHILADELPHIA, PA.

**MICA**  
CABOOSE LAMP CHIMNEYS

Save 50 per cent.

STORRS MICA CO.,  
R. R. Dept. Owego, N. Y.

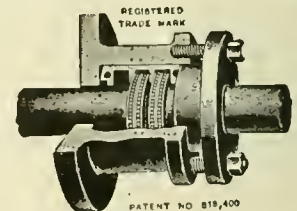

PAT. NO. 489,177	PAT. NO. 854,881
** 800,899	** 854,881
** 634,104	** 725,350
** 607,820	** 770,104
** 775,108	** 724,480

**NO MORE BILLS for PACKING**

No Cutting of Rods  
Less Oil. No friction  
Guaranteed 3 years. 30 Days' Trial  
No Pay unless Satisfactory  
Beware of Imitations. Use the Best

Manufactured only by

**Holmes Metallic  
Packing Company**

Wilkes-Barre, Pa.

Send for Catalogue K

**THE WASHBURN CO.**

Minneapolis, Minn.

**Automatic Couplers**

For Freight, Engine and Passenger Service

# Railway and Locomotive Engineering

Copyright by Angus Sinclair Co.—1907

## A Practical Journal of Railway Motive Power and Rolling Stock

Vol. XX.

136 Liberty Street, New York, September, 1907

No. 9

### Fast Trains in America.

Of all the fast passenger trains in this country probably the best known is the Empire State Express on the New York Central. This train has been run with great regularity for a number of years, and its portrait, if we may so call the picture which Mr. George H. Daniels got out, has had the widest publicity. One of our illustrations, which appears on the next page, shows this train made up of four cars and hauled by the famous

51 miles an hour, though the schedule speed between New York and Chicago is somewhat less. The photographing of these fast trains at full speed is an interesting performance and is done under very trying conditions. The most modern equipment in the way of camera, quick shutter and accurate lens has to be used in order to catch, in the briefest possible space of time, the flying train.

Some time ago when the *Four Track News* was under the charge of the former

near West Point on the Hudson. Speaking of the interesting operation of photographing the moving train he said:

"The Twentieth Century Limited, on the New York Central, between New York and Chicago, is scheduled at about 54 miles per hour. This includes stops, so that between stations the speed is constantly above that figure, and on portions of the road it is often very much in excess of that shown on the time table. At the moment when this train was photo-



TWENTIETH CENTURY LIMITED ON THE NEW YORK CENTRAL.

engine No. 999. The picture is reproduced from one that hangs in our office, and the photograph was taken when the train was running at full speed. This train at present covers the distance between New York and Albany in 175 minutes, and the mileage as given in the time table is 143.

Another and more modern train on the same road is the Twentieth Century Limited. The trip from our great city to the State capital is made in 168 minutes without a stop. This is at the rate of about

well known general passenger agent of the New York Central, who raised successful advertising to the level of a fine art, our associate editor, Mr. Geo. S. Hodgins, described the "posing" of this fast train before the piercing glance of the big camera. It must be remembered that the velocity of light is about 186,000 miles a second, and the distance from New York to the little village of Fonda in the Mohawk Valley is 186 miles. Our frontispiece illustration this month shows the train as it appeared speeding along

graphed by A. P. Yates, of Syracuse, it was running at the rate of ninety miles an hour. This means, it was covering a mile and a half in every minute, or to put it still more definitely, the Twentieth Century was rushing forward with a velocity of one hundred and thirty-two feet in every single second. The driving wheels of the Atlantic type engine which hauls the train, are six feet seven inches in diameter, and thus, at every revolution, measures off twenty and three-fifths feet of track. At the speed at which the train

was then moving these wheels were revolving more than six times each second. When one looks at the tiny divisions on a watch dial, which mark the duration of a second of time, this train-speed appears to be fast going as judged by the human eye and human sense.

Recorded on the highly sensitive, chemically-prepared retina of the eye of a modern photographic camera, which deals habitually with the almost incredible velocity of light, the racing pace of man's high-speed machine lags sadly in comparison. The camera beholds the train for but the thousandth part of one second as the latter bowls along with swing and sway in its headlong rush. In the period during which the exposure is made, the train at full speed moves over a space of one and one-half inches, while a ray of

#### Early Locomotive Building.

The following is an extract from the works of Zera Colburn and was written about 1850. It is interesting to us at the present time as it recalls the conditions and efforts of long ago. The remarks made by the writer concerning what he calls the thrilling style might almost without alteration be applied to some of the grandiloquent phrases used by some newspaper writers at the present day.

"The progress of railroads is illustrated in the establishment of shops which furnish their equipment. Within five years, during which more than 10,000 miles of road have been opened, a large number of shops have been started in all parts of the country. The competition between the new builders has done a great deal for

the infancy and youth of mechanical operations in this country. When we commenced in 1828, there was not a planing machine known; screw cutting and drill presses and shaping machines by power were scarcely thought of. Slide rests were sometimes used, but turning was generally done by the long-handled 'button-head' and 'hook tools,' and the finishing was done by the hand hammer and chisel. Steam joints were made with a lead ring on a rough surface, and packed with rusted iron borings." Under such circumstances, many of those great establishments, now holding high rank for the extent and quality of their productions, were commenced.

The locomotive builder of that day had thus not only to contend with a popular unbelief in the success of his efforts, but had also to procure, and to teach, suitable workmen, for the execution of his designs. Not always, however, could men be found having sufficient capacity to learn; or such as were contented to be taught further than in the first steps of the business. As men acquired a partial knowledge of the new work, they were apt to grow presumptuous and exacting; and it was only by a knowledge of human nature, by liberal compensation, and the possession of a strong personal influence over this class of men, that they could be always kept in a state of proper discipline and efficiency.

Nothing short of the practical talent competent to perfection of the locomotive could have supplied the machinery and fixtures necessary for its construction. The tools now in use in the Norris Locomotive Works are evidence of the industry with which these adaptations have been made and of the practical appreciation of current improvements, which has abided from the first with the management of these works.



THE EMPIRE STATE EXPRESS HAULED BY ENGINE 999.

light, one hundred and eighty-six miles long, dashes in on the sensitive plate, as the eye of the camera winks once. In that exceedingly minute fraction of time, the Limited is embraced in a glance of such startling rapidity that the camera really sees a train whose tardy motion permits swift sunlight to catch the engine bell in mid swing, to flash and play upon polished metal, and to stream in through the spokes of the well-nigh motionless wheels.

It is, as if, while the express train crawled forward the width of two postage stamps, placed side by side, a golden thread of sunlight, stretching from New York to Fonda, had sped over a distance equal to more than three and a half hours schedule run by the train, and had traced the picture upon the silver salts of the plate, in the brief moment required for the shutter to flash across the face of the lens."

the improvement of the locomotive, and towards assimilating all the styles of engines to a comparatively perfected standard. Our shops are now all capable of turning out durable and efficient machines.

There is one circumstance which deserves remark. The recent establishment of locomotive shops in the West having proved that machines of good quality can be made there, with the saving of carrying engines there, has operated to force competition among the Eastern shops. It is questionable if too many shops have not been started in the East, upon the prospect of work for Western roads. At any rate, engines are now built cheaper in the East, even allowing for the decrease in price of iron, than one or two years ago.

Our career has not been a long one, yet it has been so long as to embrace

#### PUSHING SPRINGS FOR LOCOMOTIVES.

The Cuyahoga Works at Cleveland introduced a spring of india-rubber to take the thrust of the locomotive in backing a train, and it is said to conduce very much to easy action by destroying the jar. It is also represented to be of some service when the engine is making these inquiries. But we know of a case in which the purchaser of some locomotives has alleged that a rod of three times the length of the stroke is construction, being a common cylindrical mass of rubber fixed just within the frame of the tender and is compressed by a stout bolt of iron, which leads through the frame and receives the force of the locomotive.

#### LOCOMOTIVE CONNECTING RODS.

What is the best length of a connect-

ing rod as compared with the length of stroke? What is the least length—much too short, so much so as to essentially impair the working of the engine. In our own practice we have been accustomed to consider a proportion of three and a half times the length of stroke as a desirable one where room could be had. We have, however, heard it gravely urged by an old locomotive builder, one indeed who is accounted among the best in the country, that the connecting rod should be relatively short, so as to obtain the push and pull upon the crank pin for a larger portion of the circle of its motion than where the rod is relatively long. It is evident, however, that whatever may be the advantage proposed to be gained in this manner, if indeed there is any at all, it involves increased friction on the slides.

The shortest locomotive connecting rods which we remember to have seen are some in use on the Boston & Worcester Railroad. We cannot state their precise dimensions, but should judge they were about  $4\frac{1}{2}$  ft. between centres for an 18-in. stroke, a proportion of 3 to 1. These, however, have worked for years with entire success and on inside connected engines.

In the case of ten-wheel inside connected engines, where it is necessary to connect to the forward wheels, we should have believed the same proportion to be convenient and not at all detrimental to the efficiency of the engine. So far as written authorities deserve attention, it may be said that Clark, in his "Railway Machinery," says the rod should be at least three times the length and never less than two and one-half times the length of the stroke. Bourne says the connecting rod is usually three and a half times the length of the stroke.

While the only occasion which prompts us to allude to the subject is in the circumstance mentioned at the beginning of our article, we would be glad to have any of our friends give us their opinion as to the best length of connecting rods. We wish to know if, in case an engine fresh from the shop does not at once perform to the complete satisfaction of her purchaser, he can refuse her on the sole or principal ground that her connecting rods are too short, they being three times the length of the stroke. We press the matter in earnest and we may add that the party to whom we refer stands at the head of a railroad and that he is not altogether free from engineering reputation.

#### MIDNIGHT ON THE RAILROAD.

Among all the writers of the "thrilling" school of literature—those who have immortalized themselves in "blood and thunder" dramas, in fictions of

superhuman conflicts, and unearthly tableaux—none have conceived a picture of one-half the unnatural sublimity and terrific wildness which is found in the midnight flight of a railroad train. The whole effect, in the "thrilling" style of writing, lies in the unusual character of the incident, the exhibition of extraordinary power and the actual or apparent danger of the situation. It is certainly in the two last, if not in the first of these, that the locomotive ride exceeds in effect the wildest conceptions of the novelist.

But it makes all the difference in the world that the railroad is devoted to the peaceful purposes of trade and business and pleasure travel. Did some grim warrior fly to the battlefield on a twenty-six ton express locomotive, or did a bold bandit assemble his followers at the sound of a steam whistle, or were a young knight with his lady love rushing down a forty-foot grade with a six-foot wheel and variable cut off the old gentleman in pursuit on board of a



"LINE CLEAR."

shaky old freight engine with leaky tubes—we imagine that the locomotive and railroad track would occupy considerable space in our yellow covered literature.

To an engineer a ride at any speed and at any hour is but a part of his daily duty. He sets himself to his work as a teamster seats himself behind his horses, and whatever may be the relative skill exercised by the two, the one is quite as free from enthusiasm as the other. But let the engineer contrast with the claptrap of the melodrama or the one-horse scenic effects of the ancient mythology the mystery and power of his own great flights and we believe he would experience a feeling of the superior grandeur of his own situation.

To a sensitive mind having a living admiration for the sublime and a silent awe for the deeply terrific a midnight ride on an express train would be an impressive experience. Surrounded by thick darkness, except the penetration of the long, lurid shaft of blazing light from the "head lamp," dashing onward at a speed which is revealed only by the incessant motions of the

engine, in the depth of the grandest accumulation of sound all the way from a hiss to the roar of a cataract, it does seem as if the iron steed was a veritable thunderbolt. What an unearthly glare comes up when the furnace door is opened! A wide, glowing radiance, as if the air had inflamed and was forming to the wild meteor the true tail of a comet!

No, no, it would not do for an engineer to be imaginative. He would forget himself and either dash his great machine on to ruin from not having regarded some contemptible little signal light or else blown himself into the clouds and descend only to wing a more mysterious flight to the regions beyond the grave.

#### FIRST LOCOMOTIVE BUILT IN BUFFALO.

The Buffalo *Democracy* says: "At the steam engine works, corner of Ohio and Washington streets, can now be seen a large and splendid locomotive, just finished in this large establishment. It is the finest locomotive ever built in this city. There are many new things about it, all calculated to save expense in working, and the arrangement of the different portions of the machinery will recommend it to the notice of railroad men generally. The locomotive weighs twenty-five tons, with five and a half foot driving wheels. Diameter of cylinder 15 ft., with 22 in. stroke of piston. By a most ingenious arrangement of the 'cut-off,' which is applied for the purpose of lessening the amount of steam used, but about half the steam is necessary to work this engine required by most locomotives. This is the result of the labors of Mr. E. H. Reese, the superintendent of the works, who declares that he believes he can run this locomotive with half the fuel used by other engines. The 'cut-off' is so graduated that any amount of steam from an inch to three-fourths stroke can be used according to circumstances, thus effecting a saving which we have seen accomplished by no other arrangement. This locomotive is an exceedingly powerful and handsome one and reflects the highest credit for mechanical skill and enterprise upon all who have been concerned in building it.

"The Buffalo Steam Engine Works are now ready to build locomotives of the largest size. They have now orders for six or seven to go on to the Corning Railroad. The building of locomotives is a new branch in the manufactures of Buffalo and gives further evidence of the fact that it must be in the future one of the greatest manufacturing cities in the world." If Mr. Reese has made such an improvement in the cut-off as is intimated in the above, we shall be anxious to learn what it is and to explain to our readers."

# Patent Office Department

## SUPERHEATER.

A superheater for locomotives has been patented by Mr. H. V. Wille, Philadelphia, Pa., and assigned to Burnham, Williams & Co., Philadelphia, No. 849,875. The device embraces the combination of a boiler having a front tube-sheet, a fire-box, a rear tube-sheet separating the fire-box from the body of the boiler, a crown for the fire-box and tubes extending from the rear to the front tube sheets. There is a superheater mounted within the upper portion of the boiler and extending through the front tube-sheet, the rear end of the superheater resting upon and supported by the crown of the fire-box and connected to the fire-box, a steam supply-pipe extending from the upper portion of the boiler and communicating with the superheater, and pipes in the smoke box leading to the cylinders and communicating with the superheater.

## LUBRICATING DEVICE.

A lubricating device for the surfaces of locomotive driving-boxes and driving wheel hubs has been patented by Mr. M.

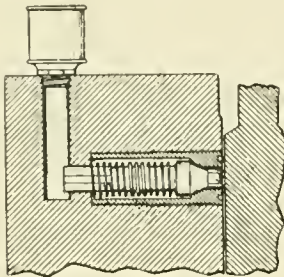

DRIVER BOX LUBRICATOR.

Millett, Omaha, Neb., No. 860,819. A horizontal passage or opening leads from the surface of the driving box to a lubricant reservoir. There is a plug securely held in the horizontal passage, and a valve stem provided with a cone-shaped head having an angular projection yieldingly held within the passage of the plug. A coiled spring encircles the valve stem to hold the cone-shaped head in close engagement with the countersunk seat of the plug. The valve is slightly displaced by the jar of the driving-box induced by the motion of the locomotive.

## LOCOMOTIVE.

A locomotive has been patented by Mr. C. L. Nelson, Montreal, Canada, No. 859,-

970. It consists of a boiler and fire box mounted on two independent trucks, the steam conduits having two independent branches and joints, one joint being located over the center of the forward truck and one over the center of the rear truck. Cylinders are secured to the trucks out-

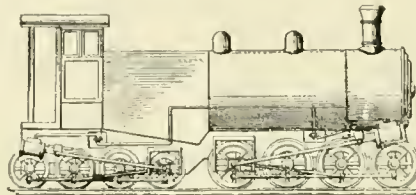

TYPE OF LOCOMOTIVE.

side the wheel line and extending above the wheels at one end of the truck. A piston, crosshead and yoke, with coupling and driving bars connect all the wheels on each truck.

## SAFETY VALVE.

Mr. C. E. Norton, Dorchester, Mass., has patented a safety valve, No. 860,820. The device consists of a casing provided with an inlet orifice and a plurality of outlet orifices, a cylindrical valve seat formed in the casing and located between the inlet and outlet orifices, and stops in the interior of the casing below the outlet orifices. A cylindrical valve is adapted to slide longitudinally in the valve seat, a packing device being located in the periphery of the valve. A valve stem projects

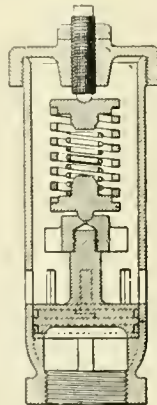

LOCOMOTIVE POP VALVE.

upwardly from the valve. A guide plate provided with wings is fast to the upper end of the valve stem, and a coiled spring is enclosed to force the guide plate and valve downwardly to hold the under side of the valve against the stops.

## CAR REPLACER.

Mr. E. H. Best, St. Thomas, Ontario, Canada, has patented a car replacer, No. 849,313. The replacer comprises a pair of members, each provided with a body having outwardly and downwardly inclined sides and a top inclined downwardly from its center to its ends. There are ribs upon the tops of the members, one having a deflecting or guiding roller at its upper and inner end and the other having a guide-rib, and a movable element to form a continuation of the guide-rib.

## CAR TRUCK.

A car truck has been patented by Mr. W. E. Symons, Chicago, Ill., No. 860,267. The device comprises a cast steel side member having extensions at its ends, each of the extensions having spaced sets

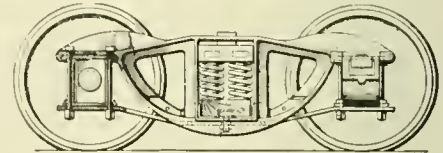

CAR TRUCK FRAMING.

of depending and oppositely extending ears provided with recessed seats in their under sides that receive the ears of the oil boxes, the extensions being provided with upright bolt-receiving openings communicating with the seats, and with pinch bar receiving sockets formed between the ears.

## HEADLIGHT FOR LOCOMOTIVES.

An improved headlight for locomotives has been patented by Mr. W. H. Donaldson, Joliet, Ill., No. 854,876. The device embraces a combination with a locomotive, of a headlight and a pivotal support therefor, a depending drum adapted to rotate with the light, a spring inclosed in the drum and connected up so as to normally tend to reverse the headlight. A pull-rope is also fastened to this drum and wound around the same and extended to the cab, and means in the cab for pulling the rope or paying it out and locking it.

## LOCOMOTIVE PILOT BEAM.

Mr. C. H. Howard, St. Louis, Mo., has patented an improvement in locomotive pilot beams, No. 859,296. As shown in the annexed illustration a locomotive end-sill or pilot-beam is formed in combination with the body, and a suitably shaped coupler-pocket and brace is formed in-



tegral therewith, and overhangs the front side of the body at the top for its entire length. The patent has been assigned to

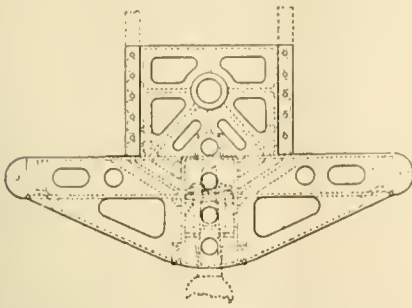

ARRANGEMENT OF BUFFER BEAM.

the Davis Locomotive Wheel Company, St. Louis, Mo.

**SUPERHEATER.**

Mr. H. Munson, Fowler, Colo., has patented a superheater for locomotives, No. 861,137. As is shown in the accompanying illustration, the device is adapted to be arranged within a circular smoke-

**Baldwin DeGlehn Engines for France.**

The Baldwin Locomotive Works have recently built twenty DeGlehn Compound Engines for the Paris-Orleans Railway of France. The cylinders are 14 3-16 ins. and 23 5-8 by 25 3-16 ins. The engines are for passenger service and are of the 4-6-0 type. The valve gear is the Walschaerts. The tractive effort exerted by one of these engines is 21,466 lbs. The total weight of the engine is 152,900 lbs., so distributed the driving wheels carry 110,000 lbs. and the engine truck 42,900 lbs., and with the weight of the tender added, the total of the two together amounts to 195,000 lbs. The driving wheels are 72 13-16 ins. in diameter and the diameter of the engine truck wheels 37 3-4 ins.

The boiler of these engines is 59 5-8 ins. in diameter at the smoke-box end and the Belpaire firebox is used. There are 139 Serve, ribbed steel tubes used,

line of the Lehigh Valley is equipped with these automatic signals and has been for some years.

On May 9th, eastbound and westbound, signals were set at danger at Flemington Junction, N. J. During the time the signals were so set, 17 trains eastbound, including 5 fast passenger trains, and 19 trains westbound, including 8 fast passenger trains were brought to a full stop. This comprised all of the trains operated on that part of the road during the time the signals were set at danger. Therefore, the test showed absolute obedience to the signals on the part of every engine-man, with no exception.

On the M. & H. Division, automatic signals set east of Hinkles, were set at "stop" on May 23rd, and while so set, 19 trains stopped at the signal, being all of the trains operated on that part of the road at that time. On the Wyoming Division on June 14th, a similar test was made with 21 trains, and each one

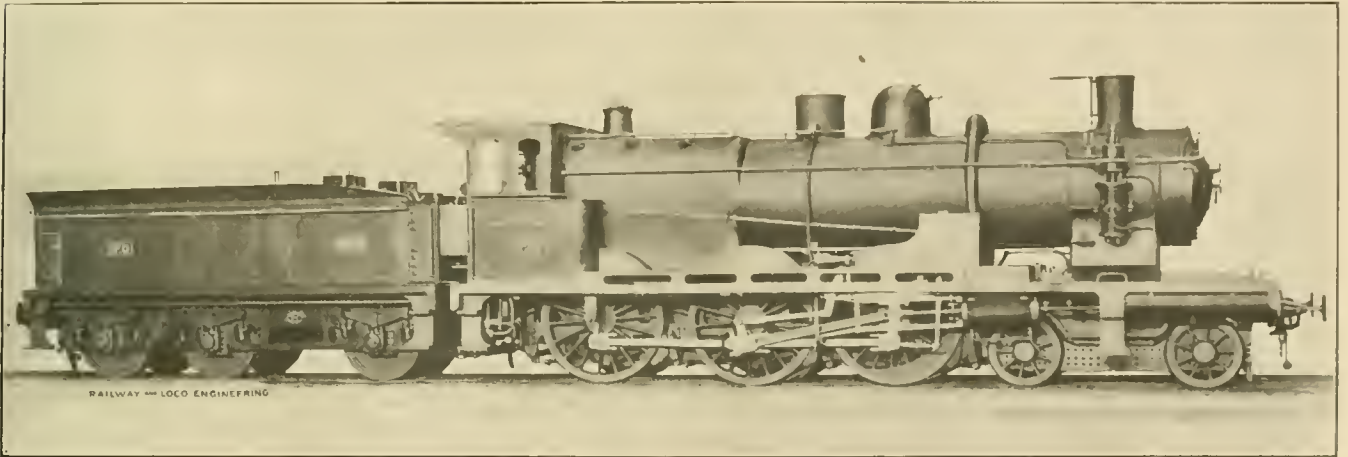

BALDWIN, DE GLEHN COMPOUND, FOR THE PARIS-ORLEANS RAILWAY.

box and consists of oppositely disposed similar sections, provided with headers having inner and outer walls forming a steam chamber, and steam pipes connecting the inner walls of the headers. There is also a draft-plate extending vertically

each having a diameter of 2 3-4 ins. and measuring 14 ft. 7 3-8 ins. long. These tubes give a heating surface of 2,402 sq. ft., the firebox contributing 174 sq. ft., making a total of 2,576 sq. ft. The grate area is 35.4 sq. ft. The steam pressure carried is 227 lbs. The firebox is made of copper with a length of 119 13-16 ins. and a width of 39 3-8 ins. The box is 82 11-16 ins. deep at the front and 57 15-16 ins. deep at the back.

The driving wheel base of the engine is 13 ft. 9 3-8 ins.; the total wheel base 27 ft. 0 13-16 in. and the wheel base of engine and tender together is 48 ft. 8 1-16 ins. The tender has a capacity of 1,580 gallons and carries 7 tons of coal.

of them was stopped. The caution signal was set against one train, which approached under control.

On June 7th, at Shields, Oaks Corners and Clifton Springs in New York State, signals were placed in stop position for 24 trains, and each one of them was stopped. On the Auburn Division, similar tests were made on April 12th, 27th and May 1st, the signals being obeyed in every instance. On the Buffalo Division, signals were placed in danger position against 40 trains on June 10th, and each one of them was stopped.

This shows the high state of discipline and the efficiency and the prompt reliable action of the engineers on the Lehigh Valley Railroad.

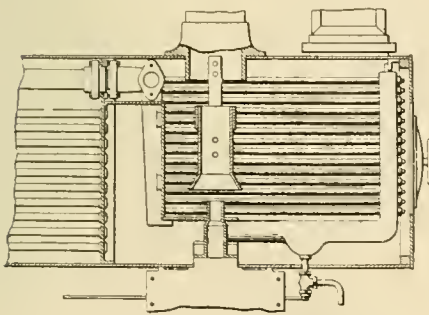

LOCOMOTIVE SUPERHEATER.

between the sections at the rear end, and a horizontal draft-plate extending under the rear of the sections. A condensing chamber and an exhaust valve underneath completes the apparatus, which has the merit of being easy of access.

**Creditable Performance.**

Information comes from the Lehigh Valley Railroad to the effect that since the introduction of automatic signals on that line some years ago, a number of surprise tests have been made. The entire main

Great Britain has made a material increase in the importation of pig-iron during the past month. Some people attribute the activity in pig-iron to desire to outweigh the levity of Mark Twain's speeches.

**Curiosities of Locomotive Design.\***

**THE ENTERPRISING INVENTOR.**

The man who ventures to stray from the familiar beaten path may stumble into a quagmire, but he may have the good fortune to discover a vein of rich ore which the beaten path would never reveal.

When an inventor scorning the common forms proceeds to work out new and original shapes for himself, he may produce something which is ridiculous and impracticable, but even when he does that, the enterprising person deserves praise,

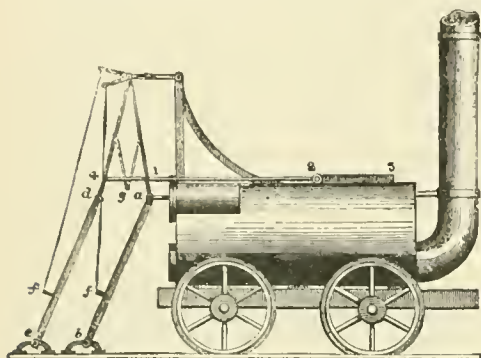

FIG. 1. BRUNTON'S TRAVELLER, 1813.

for it has been by departing from other people's lead that new and original inventions have been given to the world.

In publishing a chapter on Freaks and Curiosities in Locomotive Designs it is not done in a spirit of levity, but to give a record of well meaning inventions that did not perform the functions the inventors expected.

For the first twenty years after Trevithick built his locomotive, a belief was

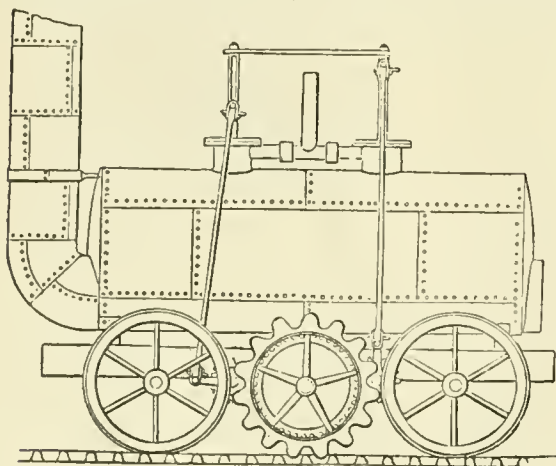

FIG. 2. BLINKINSOPP COGWHEEL LOCOMOTIVE.

common that plain wheels would not adhere to the rail with sufficient tenacity to induce propulsion. It had happened that Trevithick's engine was what has become known as over-cylindered, the effect being that the engine was furiously slippery. Other pioneer locomotives suffered from

the same defect and remedies were invented which now appear to be ridiculous.

**THE MECHANICAL TRAVELER.**

The most notable invention of this kind is illustrated, Fig. 1, and was known as Brunton's Mechanical Traveller. Brunton was aware that the action of the horse up to that time had been the most successful means of hauling vehicles, and the question arose, why not utilize the action of the horse mechanically? The engine was duly built to put that idea in practice. It had a horizontal boiler and a single cylinder set on top with piston connecting with levers that acted the part of a horse's legs.

The invention excited much attention. It had the merit of acting as the designer intended it should, and one day that it was on trial, rushing along at a speed of three miles an hour, accompanied by a host of admirers, the boiler exploded, throwing hot water, pieces of iron, and disaster among the crowd. That ended the career of the Mechanical Traveller.

**COG WHEEL LOCOMOTIVE.**

The first attempt to overcome the deficient adhesion of plain iron wheels on plain iron rails was made in 1811, by J. Blenkinsopp, who obtained a patent for a self propelling steam engine, Fig. 2, worked by a cog wheel engaging a rack rail, a practice now common on mountain railways.

This Blenkinsopp engine was the first locomotive to perform profitable traction work. It was well designed for the time, having two cylinders 8 x 20 inches, set partly into the boiler and transmitting power to right angle cranks which drove the toothed driving wheels. A sensible

feature about this engine was that the piston crossheads worked in guides instead of being controlled by parallel motion, as the pistons of most early locomotives were. The engine was used for about twenty years.

**TENTATIVE EVOLUTION.**

In the course of evolution a variety of locomotives were built resembling Hed-

ley's Puffing Billy, but they followed the line of improvement that led to the Rocket in 1829, which established the elements of a permanent type. In Great Britain there were not many departures from the foundation form of the Rocket.

An engine called the "Caledonian," Fig. 3, was bought by the Liverpool and Manchester in 1832. The vertical cylinders were secured in front of the smoke box, with pistons working through the

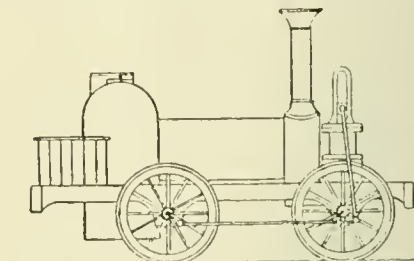

FIG. 3. GALLOWAY'S CALEDONIAN.

upper cover to connecting rods that extended down to the driving wheels. That engine displayed a weakness for jumping the track, and was changed after a few months of service. Its only service to railways was emphasizing the mistake of using vertical cylinders.

**ROBERTS' BELL-CRANK LOCOMOTIVE.**

About the same time Richard Roberts, who afterwards became a noted locomotive builder, brought out what he called the "Experiment," Fig. 4. That engine had vertical cylinders operating bell cranks which drove rods connecting with crank pins outside of the driving wheels. This engine had piston valves. It was used only for a few months.

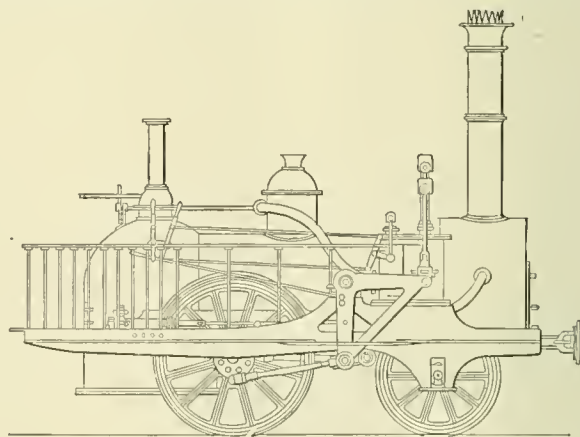

FIG. 4. ROBERTS' EXPERIMENT, 1833.

Similar locomotives were built for the Dundee and Newtyle Railway, in Scotland, one called the "Earl of Airlie," having attracted considerable attention, which did not save it from alteration after a short career.

The bell-crank method of transmitting power to the driving wheels has been used successfully for special forms of loco-

\*From Development of the Locomotive Engine, by Angus Sinclair.

tives in which it was not convenient to transmit the power direct. The real difficulty with Roberts' engines and those made for the Newtyle Railway seems to have been in the piston valves, which were crude devices.

and in the United States about 1850, had the boilers so small that want of steam reduced the speed before the train had gone five miles, when high speed was attempted.

INDIRECT DRIVING.

IMMENSE DRIVING WHEELS.  
Isambard Brunel, chief engineer of the

Although it is a recognized physical axiom that in locomotive engineering a

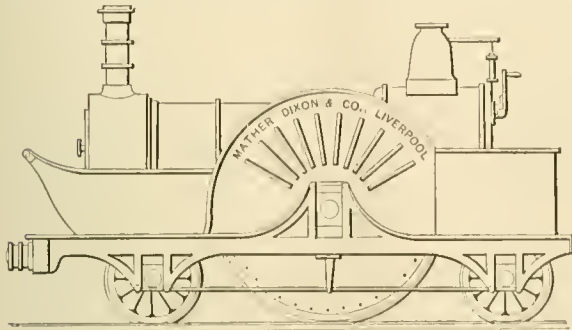

FIG. 5. EARLY GREAT WESTERN LOCOMOTIVE, WITH DRIVING WHEELS TEN FEET DIAMETER AND WIND-SPLITTING FRONT END.

Great Western Railway, of England, who made the gauge of that railway seven feet wide, had a predilection for large sizes, among them large driving wheels. An engine shown in Fig. 5 had driving wheels 10 feet in diameter. About the time that engine was built the Great Western

pull or thrust is most effective when worked horizontally, the fallacy of vertical or inclined cylinders influenced the design of locomotives for many years. Many attempts were made to increase power by means of intermediate driving axle arrangements of the type illustrated

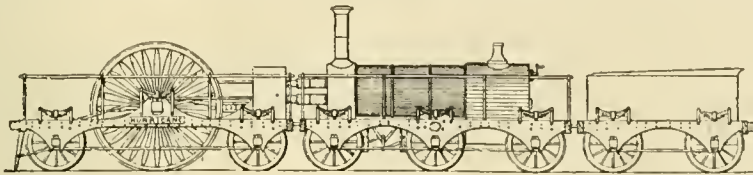

FIG. 6. HARRISON'S "HURRICANE."

Railway received one of the kind shown in Fig. 6. The latter was made according to the Harrison patent, which called for driving wheels being secured on one set of frames, the boiler being carried on another set. The science of mechanical engineering was in its infancy in those days, yet one marvels how the designer of such a locomotive expected to obtain the necessary adhesion.

A similar engineering blunder was made a few years later in the United States, when G. A. Nichols, superintendent of the Philadelphia & Reading Railroad, had a locomotive built with the boiler carried on a frame separate from the engine. Mr. Nichol's idea was fairly rational, however, for he was trying to make a boiler with grate surface sufficiently large to burn anthracite coal. Harrison departed from prevailing practice in order to apply abnormally large driving wheels.

The inclination to use huge driving wheels was based on the fallacy that the size of the driving wheels measured the speed possibilities of a locomotive. It took years of experience to demonstrate that the boiler was really what controlled the speed. Some of the high wheel Crampton locomotives, built in Europe

in Fig. 7. A very interesting attempt of this kind is illustrated in "Sekons Evolution of the Steam Locomotive." This engine was built at Bradford, England, for the Cambrian Railway. It was a vibratory engine, the special merit claimed

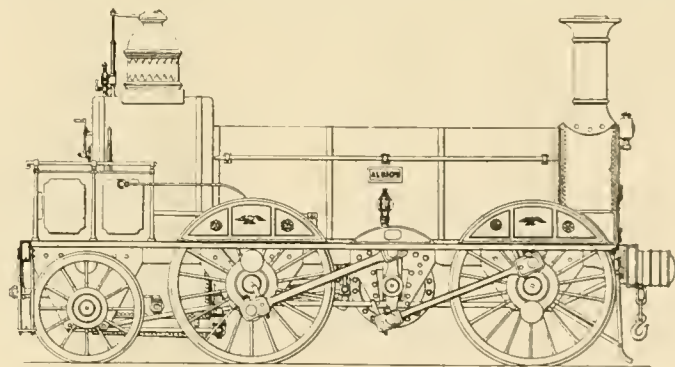

FIG. 6. "ALBION," BUILT FOR CAMBRIAN RAILWAYS.

for the arrangement of mechanism being that it produced perfect balance of the reciprocating and revolving parts. I wonder that the hammer blow alarmist never tried this engine.

The driving axle was secured between the frames and set parallel to the wheel

axles. The driving axle was secured at each end to a strong disk which held power transmitting mechanism. The pistons, which were fan shaped, drove rocking shafts secured to the driving axle and it in turn vibrated the disks to which the main rods were secured.

It was an ingenious engine, and is reported to have done good service on small cost for fuel and repairs.

Locomotives driven through a supplementary driving axle were very common in the United States, but they were used mostly in the process of evolution. All the Baltimore & Ohio grasshopper engines were driven in this way and they worked quite satisfactorily. The Camden & Amboy monster, shown in Fig. 8, had heavy spur gears on the axles of the middle pairs of wheels which engaged with an intermediate gear performing part of the work done by coupling rods.

When locomotives of that character have been built by men seeking for the best form of engine to perform the work of train hauling, their efforts were commendable, but at various times amateur locomotive designers, saturated with egotism and personal conceit, have produced ridiculous engines and sometimes their friends have tried to force them into use through stock-selling operations. A notable case of this character was the Raul Central Power locomotive, Fig. 9, built at Paterson, N. J., in 1892. The people interested in this invention tried to push it through the influence of sensational articles in the daily newspapers, their claims for speed and efficiency being senseless exaggerations, but their efforts were in vain. As usual, they blamed its unpopularity upon the prejudice of railroad men and the engineering press. The engine had two small boilers, each with a fire door on each side and a smoke flue going back to the stack in the centre.

Vertical cylinders were employed, transmitting the power through a central shaft. This engine was not only an oddity, it was a fake of the worst kind. Instead of an advance in design, it was returning to pioneer practices, being a product of combined ignorance, egotism and perversity.

Ever since people became inventors of mechanical appliances, there have been persistent attempts made to overcome the laws of nature by arrangements of mechanism designed to produce perpetual mo-

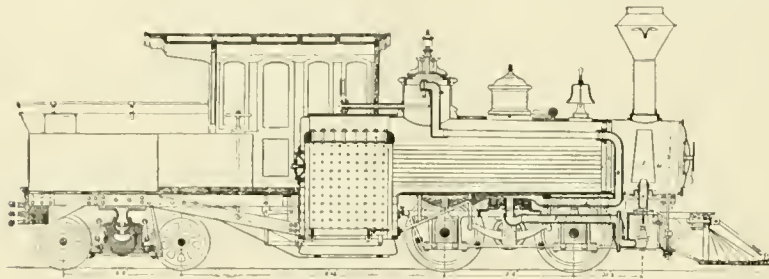

FIG. 8. MASON'S DOUBLE TRUCK LOCOMOTIVE.

tion. In some instances inventors labored to produce apparatus that would maintain motion of their own unaided volition, others labored by combinations of mechanism to gain power by levers or their equivalents.

Of this class of invention was the Harrison locomotive shown in Fig. 10. In this engine the real driving wheels, which had geared peripheries engaged with cogs on the rail wheel axle. The expectation was that excessive speed could be maintained with reduced expenditure of power, as the piston speed could be regulated at what the engineers of the time considered most conducive to economy of steam. The engine shown was built by Hawthorns of Newcastle, in 1837, the gearing being 3 to 1, so that one revolution of the driving wheels caused the rail wheel to turn three times. The "Hurricane" was used a short time on the Great Western Railway, and was said to have maintained a speed of 100 miles an hour, but that did not preserve it from premature demise. Harrison's failure did not discourage others from trying similar experiments.

The inventive habit has been cultivated for many years in the United States through liberal patent laws that enable an inventor to enjoy the fruits of his ingenuity. Owing to this there is an army of ingenious men ever ready to improve on foreign inventions, with the result that a mechanical oddity appearing in a foreign country soon appears on this side of the Atlantic in exaggerated form. The Harrison two-story locomotives had several imitations in America.

#### Thrift.

"Yes," boasted the over-dressed individual, "I can make my clothes last. This hat is an example of my thrift. Bought it three years ago, had it blocked twice, and exchanged it once for a new one at a railway restaurant a few days ago."

#### Superheaters.

At the beginning of 1906, there were, according to the Master Mechanics' Association report on superheaters, eleven engines in the United States, so

equipped and fourteen by the end of the year. On the Canadian Pacific railway there were at the end of that year, 176 engines equipped with superheaters, 22 having been removed and 97 applied. The Canadian Pacific have

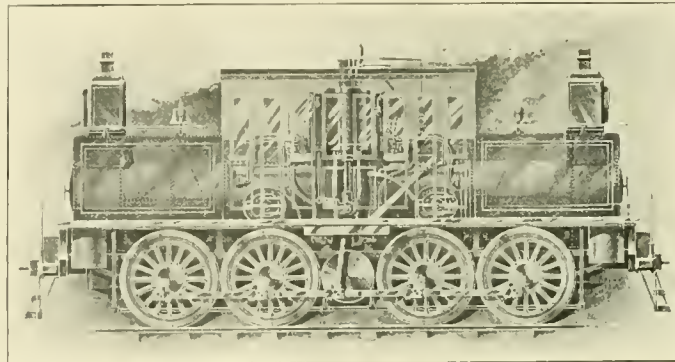

FIG. 9. RAUL CENTRAL POWER LOCOMOTIVE.

also received or have on order 176 additional locomotives equipped with superheaters. The results of observations as to the efficiency of locomotives with and without superheaters shows that superheating saves 10 to 15 per

cent of coal in freight service, and 15 to 20 per cent in passenger service. There is also a marked saving in the water consumption.

The revival of interest in superheated steam brought about by the discussions of railroad men has been infectious and we notice that those in charge of stationary engine plants are trying to find out how much fuel saving virtue there

may be in superheat. Experiments with superheating have been common since Watt's time, and mild epidemics of superheating advantages have been common. Various systems of superheating have been introduced at various times and zeal to increase their efficiency has been their undoing. A superheater that causes shut-downs soon gets on the nerves of the engineers and of the owners.

#### Wire Rope Tramway.

The usefulness of the modern aerial wire rope tramway is illustrated by a plant, recently installed for the Thacker Coal Mining Co. of West Virginia. The tramway crosses the Tug River and runs to a loading station near the top of the mountain. It has a clear span of 1,300 feet.

A wagon road from the base to the top of the mountain, and following the same general direction as the tramway, is said to be three miles long, and it requires more than an hour for loaded wagons to make the journey. The buckets of the tramway system, traveling at the rate of 300 feet per minute, make the entire distance in about four minutes.

The difference in elevation between loading and discharging stations is 360 feet, a difference which permits the tramway to be operated by gravity; that is, the descending loads on one side pull up the empty buckets on the other side. The speed of the line is controlled by two brakes, one attendant handling both levers, while another attendant loads the buckets as they enter the terminal by simply opening the coal

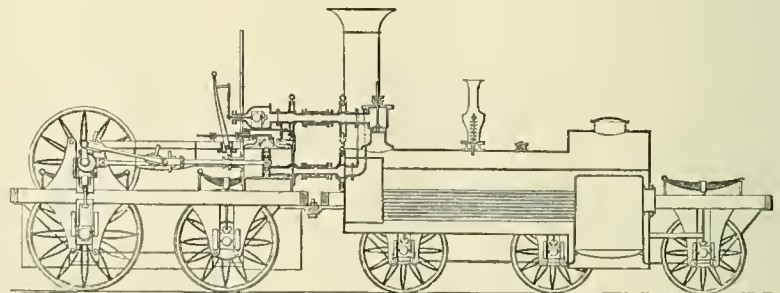

FIG. 10. HARRISON'S "THUNDERER."

gate and permitting coal to pass from tipple to bucket.—*N. Y. Commercial.*

The long evenings will be upon us directly and ambitious people will be looking for reading that will be at the same time interesting and instructive. A good guide for such people is our Book of Books, sent free on application.

# General Correspondence

## Cylinder Packing Quickly Made.

Editor:

In connection with our conversation of some three or four months ago, I am enclosing herewith a photograph of our machine for making cylinder packing.

The packing pot is first chucked properly and faced and turned on the outside to the proper size, and turned on the inside 3-16 in. small at the same time. One gang of tools cuts the lower section and the other gang of tools cuts the upper section, thus finishing the entire pot at the same time. The grooves are cut 1-16 in. deeper than the thickness of the finished ring; then the other head with the boring tool bores the ring to the finished size and as the tool comes to each groove a ring is finished and removed, the process continuing until all of the pot is worked up.

H. H. HARRINGTON,

Master Mechanic, Erie Railroad.

Susquehanna, Pa.

## Railroad Apprentices.

Editor:

I note your article on the subject of apprentices, in your December journal. This is a matter in which I have been very much interested for the past twenty-seven years, and with great success, and am sorry to note that there is not enough consideration given to the apprenticeship system, either by private firms or railroad companies. They show a lack of interest in imparting the fullest information to the rising generation serving apprenticeships at the different trades. The failure of a firm or corporation to organize a good system for apprenticeship shows a lack of patience—it requires much patience, and also requires years of time, according to the class of business in which they are employed.

A young man of seventeen or eighteen years, with a good common school education, is, in my opinion, a fit person for an apprentice at any of the trades, and with proper attention and encouragement, will prove a valuable investment to his employers. I say proper care, because care is the watchword to success in any undertaking.

Be careful not to employ only such as are fit for the trade—this can be determined by taking sufficient time to converse with the lad. Care should also be taken that you do not employ them oftener than business will permit—be careful that they are spaced far enough apart in order to give them the fullest instruction in the different positions they

will pass through during their apprenticeship, and above all, be careful that you have a good foreman, who has an interest in apprentice boys—if you have not, you had better either abandon the foreman or the boys, as the two must go together, apprentice boys fit for the trade and a foreman fit to instruct the boys. Be careful that you have a fixed plan how they shall be cared for, in order to serve the best interests of the firm, or corporation you represent, then, I think, with a little self interest on the part of the employer

not owe the firm anything for what he knows.

A four years' term, when the time is well spent in their several positions, is long enough, and apprentices properly looked after will make much better mechanics, as a rule, than any that are traveling around seeking work—in other words, if you want to have good men in your shops, spend the time on them for instruction, and make your own men.

If this plan is followed out for the next ten or fifteen years, I will guarantee

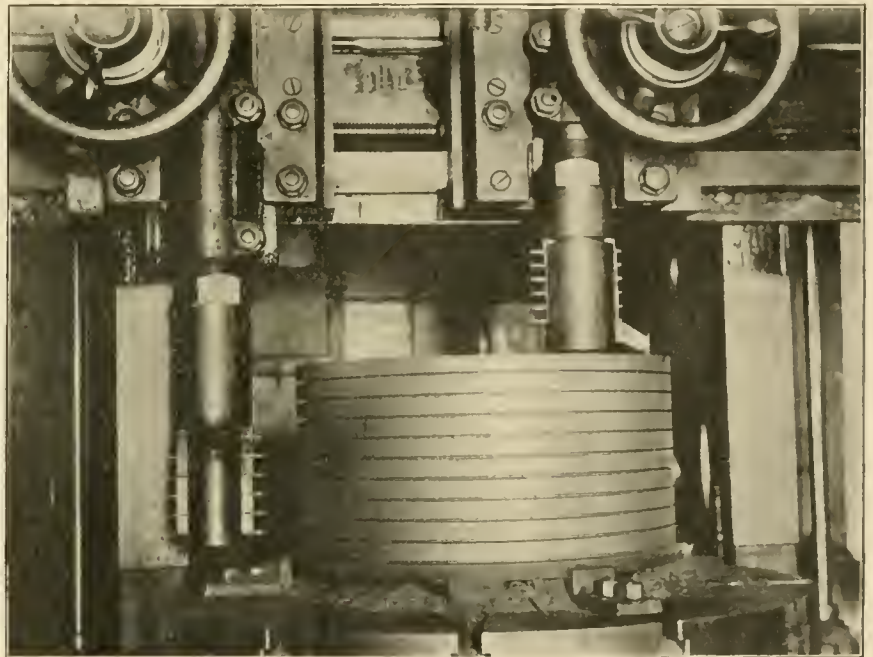

CYLINDER PACKING QUICKLY MADE ON A BORING MILL.

properly applied, he will put himself in a position to meet competition much better, and will have the pleasure of being somewhat of a benefactor to the rising generation.

It is too much the practice, both in railroad and private shops, to keep an apprentice in one position where it appears to them, he can be made the most money out of—this is an injustice to the apprentice, and shows a decided lack of interest on the part of the firm. There are many apprentice boys who would make bright workmen, if they had the proper attention, and where he does not get the proper attention and instruction, when serving his apprenticeship, and in after life succeeds in pushing himself forward and obtaining good positions, he looks backward over the time he was serving said apprenticeship, and feels that he does

that a good apprenticeship system will receive your hearty support.

JOHN TONGE, Master Mechanic.

Minneapolis, Minn.

## Advancement to Higher Positions.

Editor:

I saw a word from Fred Stiffler in the General Correspondence columns of your July paper, and it was commented on by a word for all, from the editor, on page 315. This embodies many of my sentiments exactly.

The only reason I can say which may not be correct on this subject is, that if a suggestion is taken by one in an official position from a man, in order to promote or facilitate an improvement on one of the many trunk lines of our badly blocked roads, and poor

water service, others think that some one is trying to get his job.

Now, why can not a G. M. or his assistant canvass the employees' knowledge on how to bring about this, that or the other for improvement, and give the reward to the one sending in the best solution to same. This gives the G. M. and Supt. a chance to know what kind of men he has in his employ in all departments and a chance to make a selection for officials from the ranks. How does this strike the many?

G. MORGAN MILLER.

*El Paso, Texas.*

### Education of Firemen.

Editor:

An article appearing in the August number of RAILWAY AND LOCOMOTIVE ENGINEERING, entitled "Educating Apprentices," was subsequently referred to in an article entitled "Instruction of Firemen," both of which were highly interesting and instructive. The proper education and training of the men who are to take the position of locomotive engineers in the future is a subject that should be of vital importance to every railroad company.

There are hundreds of young men now being hurried into the responsible position of an engineer without sufficient experience as a fireman to even make him a good man in that calling, let alone the making of a good engineer; these men are not nor cannot be a success until they acquire the education and training that they should have gotten while working in the capacity of a fireman, and the service rendered by this class of men is extremely expensive to the company.

Many firemen get practically all the knowledge they have and are enabled to pass their examination by delving into books on the mechanical subject for a few weeks before the time comes for their examination, and having learned the locomotive catechism by heart, they are then thoroughly prepared for promotion; information gained in this way is seldom retained for any length of time and therefore of little value to him in the future.

The system of operating railroads today is changing with wonderful rapidity. One idea has scarcely time for a successful demonstration until it is cast aside and a new one taken up. It seems that everyone in charge of operation is bent on tearing out the old and building up the new, and it occurs to the writer that it would be wise to stop a moment and inquire what the future is going to bring forth in the way of engine men.

Coming along in with the advent of the new ideas the strenuous operations and the addition of very heavy power, we have the new fireman whose sole effort in life is to try and keep the engine hot, and in fact that is all and even more than

he has time to do, for the work that is required of the fireman in getting a large engine and heavy train over the road is often more than should be assigned to any one man, and should the engine need repairs he usually spends such time upon the seat box trying to regain sufficient strength to tackle the next hill, and so he struggles along for two or three years until the time for promotion comes and he has little more practical knowledge of the operating and care of an engine than if he had been firing a stationary boiler for a heating plant.

Then comes the examination which, in most cases, is a well brought off farce; a few weeks or a month before his time for promotion he is notified by the road foreman of engines that he will call him in for examination. He procures all the books on mechanical subjects he can find and proceeds to stuff himself with knowledge which he proposes to unravel when he comes up for examination, and if he is successful in his examination that will probably be the last time he will think of the lessons he memorized, and probably it is very well that he don't retain much of it, especially some that the writer had occasion to read where the question was asked, "How do you fix a broken steam chest if steam leaks out badly?" Ans.: "I would open the smoke box and slack off bolts to steam pipe at lower end on disabled side and slip a piece of sheet steel in the joint, tighten joint again and proceed."

Some young runner might remember that if he had happened to read it in his search for knowledge before his promotion and if he should be so unfortunate as to get a steam chest on his engine badly cracked or broken he might try to fix it in that way, and does anyone suppose that there is a great railroad in this country that would tolerate having their main line or even an important side track blocked for four or five hours while some poor, misinformed young engineer was roasting his brain and inhaling great quantities of gas trying to take up the bottom joint of a steam pipe of a modern locomotive with a modern equipment of tools, viz: a broken-backed money wrench and a cape chisel, it would occur to the practical man that that instruction was at least forty years out of date.

Wouldn't it be much better if every fireman would provide himself with books, get them when he first begins and read and study them during his leisure time and apply the knowledge he gleans from them to his every-day work? Ask the engineer a new question every trip and from him and his observation he will get the practical side. From the books he will get the technical side, and that makes the best education a man can have.

The writer is of the opinion that the company should go to some considerable

expense and trouble for the proper education of their firemen. If their work is so taxing that they cannot get the practical education necessary on the road, and it is in a good many cases, then the company should put two firemen on the very heavy power and they should also provide a school of instruction at their large terminals to the end that the best education possible be afforded their prospective engineers so that when the time comes for them to step over on the right side they will be fully prepared to meet the conditions that arise and it will not be necessary to break up a large proportion of the company's rolling stock before they attain sufficient practical knowledge to successfully run an engine.

The employees of a railroad company, especially the engine men, are the life's blood of the system, and if they are of the best then there will be a strong, healthy organization. If they are inferior men, then the whole system will be contaminated by their shortcomings.

It has been thoroughly demonstrated that the only successful way to make engineers is through the position of firemen. Then as the education and training of men in every walk of life and especially that of an engineer is of the highest importance, isn't it the part of prudence for all the railroad companies to throw around their young employees, and especially the firemen, every opportunity for the gaining of good, healthy, sound knowledge necessary to make them first-class men in their final calling?

W. O. VAN PELT.

*Pittsburg, Kans.*

### Grinding Cylinder Covers.

Editor:

I see in the August number Mr. Lacey R. Johnson shows and describes a machine for grinding on cylinder covers; and this is a question I have asked dozens of engine builders—why grind them on?

If he and all other engine builders will face off the end of their cylinders with a fine feed diamond pointed tool and make the face on the head that is to fit not over  $\frac{3}{8}$  ins. wide and face it in the same way and bolt it on, they will never grind on another head unless some duffer bruises it in some way.

Don't scrape, grind, paint, grease or pack; but just put them on dry and they won't leak.

Perhaps I ought not to expect Mr. Johnson to try this any more than I prevail upon our American builders to try it, but as I always take pains to say that I learned this trick in England, he may be more easily influenced.

If they are never greased, painted or scraped they may be put on and taken off any number of times and never leak.

JOHN E. SWEET.

**Roundhouse Jig.**

Editor:

The railroad management seem to lose sight of the fact that men are not keeping pace with the increased sizes of modern locomotives. While the different parts of locomotives are getting heavier, man remains the same.

Now, "lest we forget," I would suggest that all heavy engines be equipped with a short rail, say about 30 ins. long, made of 2 x 1/2 in. iron, and secured on the under side of the running board, on each side of engine, like sketch, and having a small trolley running on it. A light chain tackle, part of round house equipment, together with suitable eye bolts, etc., to screw into oil cup or oil cup holes in strap, so that the men can pick up a back end strap and brass or back end of rod, middle connections, etc., and handle it as only heavy weights are handled. Provision is made for handling air pumps, steam chest covers, etc., but no provision for lifting straps, brasses and rods; they are getting too heavy to handle without

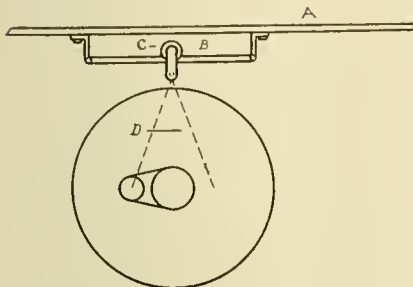

ATTACHMENT FOR LIFTING RODS.

some mechanical appliance. In my sketch A is the running board, B the rail, C the trolley, D the chain tackle. Help the round house man!

W. DE SANNO,  
Ex-Loco, Engineer and Machinist.  
Alameda, Cal.

**Air Operated Vise.**

Editor:

The accompanying illustration represents a fluid actuated vise invented by J. E. Osmer, Master Mechanic of the Northwestern Elevated Railroad of Chicago. They are designed especially for railroad machine shops and roundhouse uses. Air used in closing the vise is also used for opening the same, due to the difference in area of the piston head when the pressure on each side of the piston head is equalized. The movable jaw can be reversed or brought to a sudden stop by simply lapping the valve.

The No. 7 vise, for example, has a 7 in. jaw, 7 in. cylinder, 11 in. opening between jaws when wide open, 4 in. piston rod made of steel. This vise at 100 lbs. per sq. in. will give a grip force between jaws of 2,590 lbs. In this construction an increased shop output is obtained without manual energy when these vises are

used on the rod bench, link bench or in the round house. One single 1/2 in. iron pipe is used, but when a slight, medium or intense pressure is desired in the same vice, 2 or possibly 3 pipes may be used, each having a difference in pressure and controlled with reducing valves, such as

clean the interior of all passenger coaches with compressed air appliances, but coarse painting, such as for freight and coal cars, is applied by the same force, and the rapidity with which it is spread is calculated to make an old-time painter, with pot and brush, green with envy.

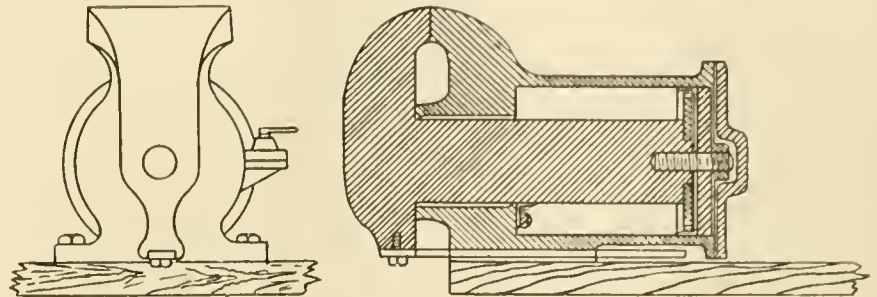

AIR OPERATED VISE FOR RAILWAY SHOPS.

the ordinary air signal reducing valves in train service.

J. E. OSMER.

Chicago, Ill.

**Interesting Railroad Shops.**

Editor:

A few days ago I found myself in the beautiful city of Rochester, N. Y., with a few hours' spare time on my hands. In answer to my inquiry as to car building or repair shops, I was directed to Lincoln Park, where are situated one of the great plants, for this purpose, of the Buffalo, Rochester and Pittsburgh Railroad. Here I found a very hive of industry and well directed energy; also less red tape than usually obtains in such institutions. In place of a ticket admitting inspection of some nook or corner of the shops, I was furnished with a guide, who was told to show everything I wished to see.

I was soon much interested in my guide, for he attempted explanations of such matters only as he understood. In answer to a question he said, "No, I am

From the paint department we went to that of the air brake. Here I was shown a machine called the Twentieth Century Outfit for mounting new and removing old air signal and steam hose. Asked as to how many air hose he could mount in a day, the young man who was operating the outfit told us he could mount as many in an hour as a man could by hand in all day, and what I saw him do in the few minutes I watched his operations, confirmed his statement. This machine seemed to be a pet of the men in this department, for the reason, as I was informed, that it "was invented and patented by one of the boys right there in the shop."

The B. R. & P. R. R. and G. T. R. are interested in a car ferry, which is expected to go into operation in a few weeks, between the port of Rochester, N. Y., and that of Coburg in Canada. The capacity of each boat will be equal to the ordinary train of loaded coal cars. The distance from port to port is about 50 miles, but this saves a railroad haul of

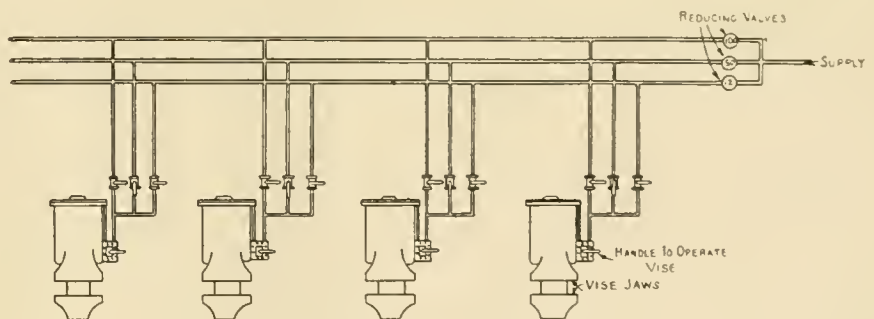

PIPING ARRANGEMENT FOR AIR OPERATED VISES.

not a railroad man yet. I am here to fit myself for the business." This remark covered the ground, and from it and what I was able to see of my young friend while in his company, predict that he will be heard from later on, and higher up.

Compressed air is used extensively in these shops, as is the case in all up-to-date institutions of the kind. They not only

over 200 miles. It is to be operated by the Ontario Car Ferry Company and will make daily trips between the two ports.

I have visited many shops of this kind, but judging from what I was able to see in the limited time at my disposal, there are few, if any, that will rank those of the B. R. & P. in Lincoln Park.

Lockport, N. Y.

SUPERB.

### Leaky Flues.

Editor:

It is my desire to offer a few items, which, in my opinion, is of sufficient interest and importance to our many locomotive friends, that by examining them carefully, and practicing the suggestions offered, they may receive some aid in their arduous work.

The question of leaky flues of modern locomotives should receive more careful attention from the men in charge, than they usually get. Upon this particular question I have made some experiments and observations, which in my opinion, is valuable. I noted that some engineers can run a locomotive several months without flue troubles of any kind, others can only run an engine a little while until the flues show signs of weakness and distress, and about every telegraph office they arrive at, wire headquarters that the flues of engine so and so are leaking very bad and would

culatation, if any, in the boiler; consequently the cold supply of water falls toward the bottom of boiler and chills the lower rows of flues and thereby causing them to contract and pull into the flue sheet, partially destroying their beads, and this practice continued from day to day, finally results in serious damage to flues. I've heard engineers and firemen; lots of them, say that the beads are burned off the flues. No such thing, I assure you my good friends; beads are broken and pulled off by the contraction of flues, and not burned. I wish to direct your attention to a set of flues with beads broken and partially off. It will be noticed that the ones with beads off are about the center of flue sheet, and below the center line, usually. There is a reason for this, and on this wise. When the cold water is kept pouring into the boiler, after circulation has ceased, the heat rises to the top, thus maintaining as nearly uniform

pressure, water and extra coal, in favor of momentum, he starts with his train from any point with the necessary amount of water in the boiler, and gives the fire a chance to raise the pressure to near its maximum when the injector is put to work where it will supply the boiler, and notches up the lever and keeps it as near the center of quadrant as the engine will do its work to the best advantage, thus getting the greatest benefits from steam expansion, but then oft times steam expansion must be lost sight of when the engine is working to its maximum to get the train over the hardest pull, if, however, the engine has been given a good show before the hard pull is encountered it can be greatly favored when the opportune time comes and leave no bad effects to the flues.

When the engine is brought to a standstill from any cause, and the water is fairly low in the boiler, the injector should not be allowed to continue to work for any great length of time, lest the cooling process to flues and sheets develop. One to two inches of water is a sufficient amount to inject into a boiler while there is a cessation of circulation.

Now, as to the second question you raise. I will add that this one is hardly worth considering, as it seems absurd to undertake to get a heavy tonnage train from one siding to another to get out of the way of train having the right of track over you, unless you have the time required by the company's rules to go there and get out of the way and clear them according to rule. In other words, never take any more out of the engine than it is able to give satisfactorily, and when you have accomplished this you will begin to reduce your engine failures and enhance your value as a locomotive engineer.

There is a good deal of speculation recently among young runners, and some old ones, as to the best method of locating a broken balance strip spring, or strip, while on the road. Of course, when this befalls an engine the reverse lever is always trying to tear itself out of the quadrant, and the larger the steam chest and valve, the more anxious is the lever to tear things to pieces, to say nothing of trying to notch it back under a steam pressure. Some would endeavor to locate this bit of annoyance by listening to the blow from the exhaust, but in large engines with heavy cylinder castings this is very difficult to do, the blow is then very light, and then it can hardly be definitely ascertained from which side it comes.

I will give my idea of how to more accurately locate the trouble, and you will no doubt agree with me that it will prove to be a more sure way.

For instance, if you should think it is on the right side of the engine, place it on the upper or lower quarter on that



TANK ENGINE BUILT IN GERMANY FOR THE MATHERAN RAILWAY.

like to cut down, in order to get in without having to dump the fire, etc.

I will endeavor to give, what in my opinion, is the cause for many of such failures. The engine will leave the terminal with a heavy tonnage train, not much attention given to the amount of water in boiler, perhaps the fire is not as heavy as it should be, the engine is worked hard for some considerable distance and steam pressure falling, perhaps, the fireman is working hard with his fire to get it into good condition, all this time the supply of water in the boiler is getting low, anxiety is beginning to rise in the engineer, and the injector is put to work, the engine struggles along as best it can and finally reaches the first stop with perhaps one gauge of water in boiler and the steam pressure down 40 or 50 lbs., below the maximum, maybe the left injector is set to work along with the other one, the blower is kept working strongly and in a little while the boiler is filled with cold water. Of course, while the engine is standing idle there is but very little cir-

as possible, a happy medium, so to speak, between expansion and contraction, and the beads of these flues will be found in good condition, while those in the center, or below the center line of flue sheet are broken and torn off.

It is not my wish to be understood that this is true of all cases of flue failures from one stopping to another, but it is largely so of all cases of new flues.

The engineer who is desirous of getting the best results out of a set of flues is always anxious to carry the water as uniformly as possible in the boiler of the engine he is in charge of. Well, you tell me that this cannot always be done, due to the fact that you must get up a certain amount of momentum to help the engine get the train over the hard pulls, and make other certain points for trains who have the right of track over you, etc. In answer to your first proposition I'll agree with you that a little momentum is a valuable aid to an engine in getting up and over a hard pull, but an engineer who uses good judgment never sacrifices steam



side, set the brake, open the throttle and admit a good quantity of steam to the chests, then move the reverse lever from full forward to full back motion, if you can, if you cannot do this you will find the trouble is on that side. The side the engine stands on the quarter, by moving the reverse lever back and forward, as indicated, the valve travels the throw of the eccentric, which amounts to  $5\frac{1}{2}$  to 6 inches, as the case may be. On the side the engine stands on the center, the valve travels but very little, if any, and if the spring or strip should be broken on that side the reverse lever can be moved, as indicated above. The longest travel of valve with the load on it under the steam pressure will tell you every time just where the trouble is and you can report the correct side to have the steam chest cover removed and the necessary repairs made. And in this correct report to the

#### 2-8-0 for the Tonopah & Goldfield.

The Baldwin Locomotive Works have recently built for the Tonopah & Goldfield Railroad three heavy Consolidation locomotives. The maximum grades on this road are 33 per cent., and these engines will be used in both freight and passenger service. They can exert a tractive effort of about 39,160 lbs., and the hauling capacity at slow speed, exclusive of engine and tender, on a straight grade of 33 per cent., is about 360 tons.

As shown in our illustration, these engines are equipped with single-expansion cylinders, 24 x 28 ins., and balanced slide valves which are driven by the shifting link motion. The eccentrics are placed on the third driving axle, and the eccentric rods are straight. The links are placed back of the second axle, and the link blocks

tween them. The wheel base of the engine is 25 ft., the driving wheel base being 17 ft. When the wheel base of the tender is taken into consideration the total of engine and tender becomes 58 ft. 11 ins. The weight of this engine is 207,450 lbs., the amount carried on the drivers is 185,600 lbs., while that on the engine truck is 21,550 lbs. With the tractive power given above, and the weight on the wheels as stated, the factor of adhesion is 4.7. The total weight of the engine and tender taken together is about 340,000 lbs.

The cab of this engine is of steel, with one large window conveniently arranged in each side. Suitable steps and hand holds are provided. Steam heating apparatus and an electric headlight are included in the equipment.

The boiler is of the wagon-top type with three rings in the barrel, the sec-

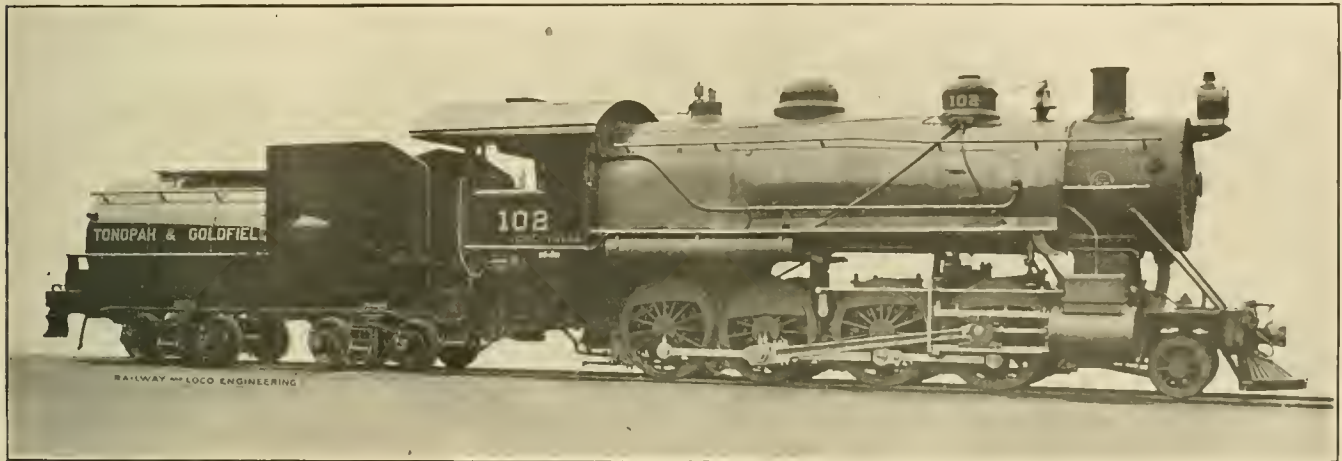

HEAVY 2-8-0 ENGINE FOR THE TONOPAH & GOLDFIELD.

A. B. Phillips, Master Mechanic.

Baldwin Loco. Works, Builders.

shop you will be considered a man of knowledge, and you are to the good there again.

An engineer cut out his engine a little while ago on account of the upper discharge valve broken in a nine and a half air pump, and received his "bumps from the old man" for his neglect to overcome the difficulty. He was drawing a 30 car train, all coupled up. There was no need for the cutting out of the engine.

What he should have done, remove one of the receiving valves and placed in where broken one was, which would have given him the advantage of a half pump, and to have brought the train and engine to terminal. But he was not in possession of the required knowledge to interchange the valves aforesaid, and discipline was administered, which is despised by all men in the locomotive service, who have a little pride about them.

A word to the wise, is sufficient, however.

JAS. SPELLEN,  
Road Foreman of Engines, B. R. & P. R'd.  
Du Bois, Ia.

are connected to the rocker shafts by short transmission bars. As the valve rods are necessarily long, they are supported each in the guide yoke. This is a simple arrangement of valve motion, and as the eccentric rods and transmission bars are straight and comparatively short, the tendency of these parts to spring is reduced to a minimum. The guides are of the two-bar type, and are braced by a wrought iron guide yoke, which is made in one piece. All the driving wheels have cast steel centres with flanged tires. They are 63 ins. in diameter. The main rods are of I-section, with strap stubs at the back ends, while the side rods are of rectangular section with solid end stubs.

The main frames are of cast steel, 5 ins. wide, with double front rails. The brake hanger bosses are cast in one piece with the frames. The engine truck is equalized with the first and second pairs of driving wheels, while the third and fourth pairs are equalized together with inverted leaf springs be-

ond ring being tapered. The smallest measures 74 ins. in diameter. The dome is placed on the third ring, which has a welded seam on the top centre line, with a heavy liner inside. Two rows of T-irons are used to support the front end of the crown sheet; otherwise the fire box is radially stayed. The throat sheet is sloped to clear the driving wheels, while the back head is straight. The mud ring is double riveted; it is of cast steel, and is supported on buckle plates at each end.

The steam pressure carried in this boiler is 180 lbs. There are 391 tubes, No. 12 gauge, 2 ins. in diameter, and each 15 ft. 9 ins. long. The heating surface derived from the tubes is 3,207 sq. ft., while the fire box contributes 181 sq. ft., making a total of 3,388 sq. ft. The grate area is 49.5 sq. ft., and the ratio of grate area to total heating surface is therefore as 1 is to 68.

The tender is of the Vanderbilt or cylindrical type, with a tank of 7,000 U. S. gallons capacity, and 13 tons of

coal can be carried on the tender. The trucks are of the arch bar type, with steel bolsters. The wheels are of solid rolled steel made by the Standard Steel

right hand quadrant, and at night each position is indicated by a different colored light. When the arm is horizontal a red light is displayed, when it is raised to an

fact that the lower arm and light are not distinctly under the upper arm and light, but located toward the left, so that the lower arm appears about two feet shorter than the upper one and the lower light shows on the left hand side of the post, while the upper one shows on the right hand side. This staggered relation of the two signals is very noticeable both in daytime and at night.

Class C—Signals which Give Information Only and do not authorize or restrict train movements: Switch indicators, both home and distant; flag station, water tank and stop and slow signals, indicated by horizontal lights and special designs for day indicators. These signals are all low and do not interfere with the two-signal principle used on the high poles.

Fourth—Signals Designate the Speed of the Trains Rather than the Routes, at points where interlocking systems are used.

The Top Arm Governs the High Speed Track, provided no crossover movement is inconcluded in the route. It indicates proceed at highest speed permissible, modified,

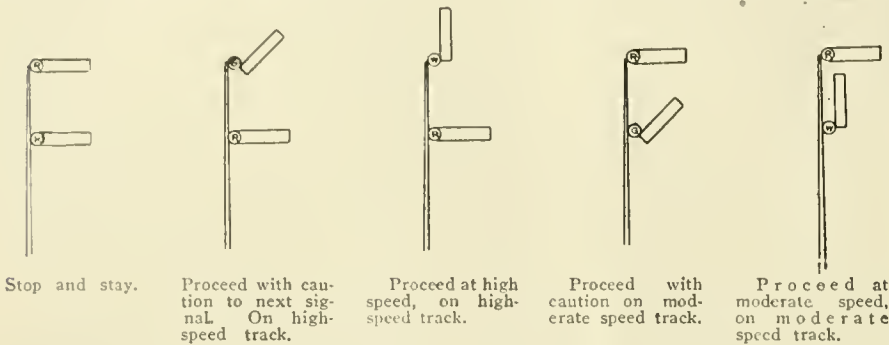

Works. A few of the principal dimensions are here appended for reference.

- Boiler—Thickness of sheets,  $\frac{3}{4}$  and 13-16 ins.; fuel, soft coal; staying, radial.
- Fire Box—Material, steel; length, 108 ins.; width, 66 ins.; depth, front, 69 $\frac{1}{2}$  ins.; depth, back, 60 $\frac{1}{4}$  ins.; thickness of sheets, sides,  $\frac{3}{8}$  in.; thickness of sheets, back,  $\frac{1}{2}$  in.; thickness of sheets, crown,  $\frac{3}{8}$  in.; thickness of sheets, tube,  $\frac{1}{2}$  in.
- Water Space—Front, 4 $\frac{1}{2}$  ins.; sides, 4 $\frac{1}{2}$  ins.; back, 4 ins.
- Driving Wheels—Journals, main, 10x12 ins.; journals, others, 9x12 ins.
- Engine Truck Wheels—Diameter, front, 33 ins.; journals, 6x10 ins.
- Tender—Wheels, diameter, 33 ins.; journals, 5 $\frac{1}{2}$ x10 ins.

angle of 45 degs. a green light is displayed, and when it is still further raised to a vertical position a white light is displayed.

Third—Class A.—“Stop and Stay” signals which authorize or restrict train movements, and at which a train, if it is stopped, must stay until the signal is changed allowing it to proceed. This class includes interlocking, train order,

Signals on the Pennsylvania.

A new system of signals has recently been tried on the Pennsylvania Railroad, and the results of its operation are of interest to railway men. The system was devised by a committee appointed by the railroad to investigate existing methods of signal operation and to recommend a system which could be adopted over all their lines.

The principles which govern the new arrangement are as follows: First—Two arms and two lights are displayed on every high signal. With existing signal arrangements the number of arms and lights is variable. A small arm with a lower power light is, at times, placed further down on the post or on a separate low post, but is so far away from the two main signals and of so much smaller size and less powerful light, that it does not

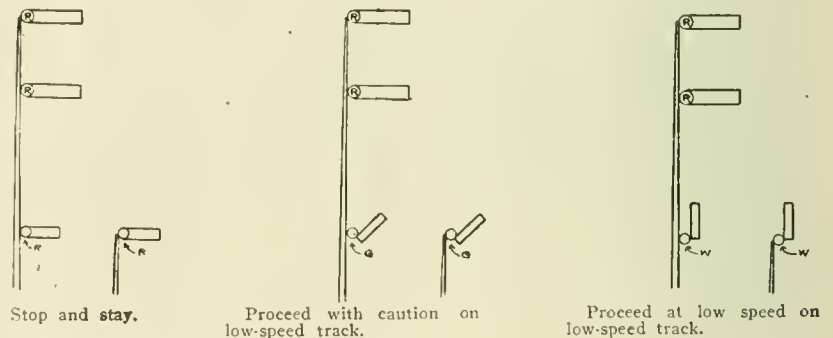

controlled manual, manual controlled and telegraph block signals. They may be distinguished by the fact that the lights are vertically over one another and the arms appear the same length.

Class B—“Stop, Wait Time and Proceed” signals which authorize or restrict train movements and past which a train, if it is stopped, may proceed after waiting time, even though the signal has not changed and still indicates stop.

of course, by curves or any arbitrary order placed up on the speed.

The Second Arm Governs Medium Speed Movements, and refers to a divergence from the high-speed routes, such as an easy crossover upon which a speed of forty or fifty miles an hour is proper.

The Third Arm governs low speed movements; over short crossovers, against traffic, into sidings, etc. This arm is shorter than the other two, has a short range light and is placed much lower down the post than the two main signals.

The interpretation of signals is given below.

Red Light and Arm Horizontal—“Stop.”  
Green Light and Arm at 45 degs.—“Caution.” Proceed to next signal which is now at “stop.”

White Light and Arm Vertical—“Clear.” Proceed at speed, next signal at “clear” or “caution.”

All interlocking signal arms remain normally in the horizontal position and at night show a red light. The arms are moved one at a time, so that an engineer cannot pass any signal post unless the signal for his particular movement is at

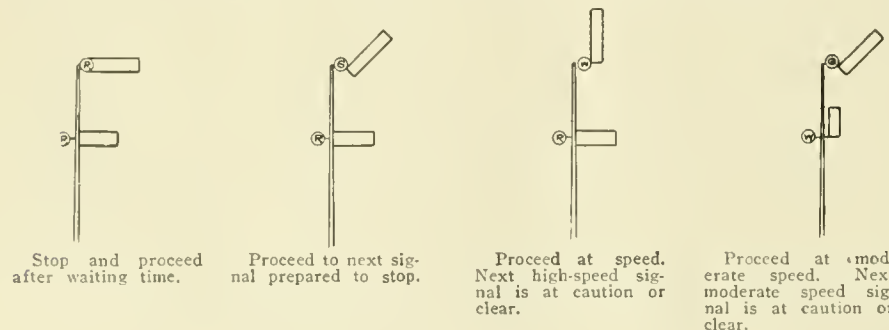

interfere with the two arm light principle.

Second—Day indications are given by three positions of the arm in the upper

This class includes automatic signals (and incidentally distant signals when the latter are used as independent indications). They may be distinguished by the

"Caution or Clear." The other signals on the post would all be at "Stop."

On the signal posts where no high speed route exists, the top arm is fixed in the horizontal position and the light is always red. At signal posts where no cross-overs or moderate speed routes exist the second arm is fixed in the horizontal position and the light is always red. The only case when the top and second signals would both be out of horizontal position at the same time is on an automatic signal pole where the lower arm would act as a distant signal for a medium speed route controlled by an interlocking tower ahead

#### Transportation and Space.

Ohio's railroad commission has put itself in conflict with the opinion of the inter-state commission as to the right of railroads under the law to contract with newspapers to exchange advertising for transportation. They have ruled in favor of such a proposition, but, of course, their determination governs only so far as the state is concerned. Commenting upon the matter, an official of one of the roads says:

"At no time has there been any doubt in the minds of railroad people as to the right of the railroads to accept a consideration other than cash for passenger transportation. We have expected just such a decision as has been made by the state commission, and believe the inter-state commission will be compelled to reverse its original opinion, all law and precedent of barter and trade being ignored by its holding.

"If advertising space has a value and is bought by a railroad, it can certainly be paid for with a commodity of equal value, be it cash, transportation service or something else. It is only a question of time when the federal commission will have to submit to being overruled."

The ruling of the Ohio commission is very broad, in that it holds that the railroads may accept anything of equal value for transportation, and that a cash consideration, as insisted upon by the inter-state commission, is not compulsory.—*N. Y. Commercial.*

#### Shire Oaks Round House.

The Pennsylvania Railroad has completed a new round-house at Shire Oaks, Pa., on the Monongahela Division. The heavy movement of coal and coke from the Uniontown territory, and of the products of the iron and steel mills south of Pittsburgh, necessitated improved facilities for housing and preparing engines. The new round-house at Shire Oaks is built of concrete and cement, with a plaster superstructure. In order to obviate the effects of the corrosion of steel from coal gases, the interior of the building is finished in wood.

#### Corrugated Tubes.

At the recent Master Mechanics' Association held at Atlantic City, Mr. George W. West, superintendent of motive power of the New York, Ontario and Western, spoke in an interesting way of the results achieved by the use of corrugated boiler tubes for locomotive service. He said that it had been found that by practical tests when engines were equipped with corrugated tubes that the mileage of such loco-

Railroad Company and others have conducted experiments by pumping cold water into boilers that had been purposely overheated and nothing worse occurred than making the sheets leak, due to the sudden contraction, but these acts of enlightenment appear to exercise no influence whatever upon the minds of people cherishing the explosion theory.

The belief that water must not be injected into a hot boiler has a most detrimental effect in the management of boil-



PENNSYLVANIA SIGNALS, STOP, WAIT TIME AND PROCEED SIGNALS.

motives was double that made by engines equipped with ordinary tubes. Another advantage was the absence of hot sparks thrown from the stack, which resulted in a large saving of paint on front ends, and proved that more heat had been abstracted from the hot gases than was usually the case.

#### Injecting Water Into Hot Boilers.

One of the most pernicious popular fallacies is that injecting water into a hot boiler is almost certain to cause an explosion. It is difficult to understand how this fallacy originated, but it is blindly believed in by thousands of people who ought to be better informed. The United States Government, the Pennsylvania

ers, for it sometimes happens that the man in charge could prevent a boiler from serious damage if water was supplied promptly when the crown sheet was found to be dry. The fear of increasing the danger by starting the injector leads many men to draw the fire, which makes a bad case worse, for the intensified heat and the delay connected with dumping the fire burns sheets that otherwise would only be slightly scorched.

In urging that water be instantly supplied when a boiler is found to be overheated, we do not mean to imply that there is no danger from explosion through neglecting the water supply. The danger is from the weakened condition of the sheet from overheating.

# Railway and Locomotive Engineering

A Practical Journal of Railway Motive Power and Rolling Stock.

Published Monthly by

**ANGUS SINCLAIR CO.**

136 Liberty Street, New York.

Telephone, 984 Cortlandt.

Cable Address, "Loceng," N. Y.

Glasgow, "Locanto."

Business Department:

**ANGUS SINCLAIR, President.**  
**JAMES KENNEDY, Vice-President.**  
**JAMES R. PATERSON, Sec'y and Treas.**

Editorial Department:

**ANGUS SINCLAIR, Editor.**  
**GEO. S. HODGINS,**  
**JAMES KENNEDY,**  
**CLARENCE RENSHAW,** } Associate Editors.

Advertising Department:

Eastern Representative, **S. I. CARPENTER, 170**  
Summer St., Boston, Mass.

British Representative:

**THE LOCOMOTIVE PUBLISHING CO., Ltd.,**  
Amen Corner, Paternaster Row, London, E. C.

Glasgow Representative:

**A. F. SINCLAIR, 15 Manor Road, Bellahouston,**  
Glasgow.

## SUBSCRIPTION PRICE.

\$2.00 per year, \$1.00 for six months, postage paid in the United States, Canada and Mexico. For other parts of the world, \$2.50, or ten shillings. Single copies, 20 cents. Remit by Express Money Order, Draft, Post Office Order or Registered Letter.

Mailing address can be changed as often as necessary—always give old and new address, and if you subscribe in a club, state who got it up. Please give prompt notice when your paper fails to reach you properly.

Entered at the Post Office, New York, as Second-class mail matter.

Copyright by Angus Sinclair Co., 1907.

For Sale by Newsdealers Everywhere.

## Causes of Boiler Explosions.

We have received a letter from a correspondent who takes our chief editor to task for opinions which he had expressed through a daily paper concerning the effect of injecting water upon hot boiler sheets, and the question is put, "What is the cause of boiler explosions anyhow?"

In regard to boiler explosions we have always admired for its force, brevity and truth the introduction to a report on the subject by a committee of the American Railway Master Mechanics' Association, which reads: "Explosions occur from over-pressures. It matters not whether the whole boiler or only a portion is too weak to resist the pressure." In other words, the strength of the boiler was not equal to the strains that were brought to bear upon it. Nearly all the boilers that explode go to pieces under the ordinary working pressure that they may have successfully resisted for years without the least sign of distress. But while the pressure continued to be held up to the usual maximum, the boiler kept slowly deteriorating and the day came when the vessel could no longer withstand the old working pressure. The pressure did not vary in its intensity, but the boiler sheet, seams or stayed surface became weaker and weaker; then disaster arrived. That

disaster was nearly always a great surprise to the people acquainted with the boiler.

Deterioration begins the day steam is raised on a new boiler and its progress ought to be carefully watched, but that precaution in the interests of safety is very often neglected. So long as a boiler gives no signs of weakness or decay the men in charge too often conclude that nothing is wrong demanding remedy. They house themselves in a fool's paradise until the unexpected disaster comes. Deterioration of boilers proceeds from various causes and some types of boilers are much more susceptible to weakening influences than others. The records of boiler explosions point out the types that are most likely to be the subject of accidents and ought therefore to be most carefully watched.

The prevailing tendency towards high boiler pressure is bringing its harvest of disaster and the probability is that that harvest will grow more profuse as years roll by unless proper precautions and remedies are applied without delay. Unduly high pressure is a menace with all classes of boilers, but it is peculiarly dangerous in boilers that have uneven strains due to errors of design or construction. A badly designed boiler is much more difficult to keep in safe condition than those of good form and on that account must always be the object of constant solicitude.

All boilers cannot be made in the best form for durability and meet the many requirements that are demanded of them, and when this fact is plain it then becomes the duty of those having charge of boilers to govern their work accordingly.

The worst form of boiler can be kept in safe condition by proper inspection and repairs, the cost of which will be in proportion to the form and amount of pressure carried. One of the greatest troubles that exists in having boilers cared for is that those having charge of the work will base their opinion and actions on who made the boiler, and how long some other one has run without repairs, not taking into consideration that they are of very different form and in different service.

When you come to the locomotive boiler, it will be seen that nearly all explosions are caused by the failure of stay bolts, and when this is not the cause the next most prolific cause is the hot crown sheet, which becomes weak by over-heat, and the result is it goes down, leaving the stay-bolts. The only remedy for this is to keep water on the crown sheet when there is a fire under it, and that is much less trouble than it is to always keep good stay-bolts in a boiler, which is one of the most important points, and requiring more judgment than any other thing in the care of boilers. It can only be done by constant inspection, by careful

and competent inspectors, the best of which will make some mistakes, but when doing so they will generally be on the side of safety, as in case of thinking that a bolt is broken when it is not; this always results in getting a new one in place of an old one, which if not broken, is much more likely to break than one just put in.

## Instruction in Signaling.

There is a school for instruction in signaling in existence on the Great Western Railway of England. The remarkable thing about this school is that it is not intended for signalmen; they get their instruction elsewhere. The students who attend this school are embryo stationmasters, and the intention is to afford them the means of becoming acquainted with the duties of signalmen and with the intricacies of the art, for the purpose of increasing their general efficiency and enabling them to better insist on expeditions and safe working.

The school at Paddington is equipped with charts, photographs, etc., and there is a model junction and locking frame on a table in front of the class when school is in session. This model is said to be the most perfect thing of its kind in the world, and was designed by Mr. A. T. Blackall, the signaling engineer of the Great Western Railway. Students have the satisfaction of seeing the practical working of a typical railway junction in miniature, and explanatory lectures accompany the demonstration.

The method of testing the knowledge of the members of the class is for the instructor to state or propose the passage of a certain train through the junction, and he gives the class the route; that is, he may say this train will hold the main line all through, or he may say it will leave the main line and go over such a line to such and such a branch, and the class are expected to write down on paper the numbers of the signal levers which will have to be moved in order to set up the route and display the proper signals. It then becomes possible to demonstrate the correctness or incorrectness of the answer given by any student, as the levers of the model can be worked before the class. If a wrong answer is given, the model reveals the defect at once. In this way it is possible to show the necessary sequence in each signal and switch movement, and as the junction is interlocking it proves to the class, that although the signals cannot be made to give false indications, it is yet possible to lose time and delay trains by the slow or inaccurate working of the system. The knowledge gained by this kind of exercise is most valuable to men who will have to deal with signalmen.

### The Walschaerts Valve Gear.

Apart from the general increase of weight in locomotives the introduction of the Walschaerts valve gear has been the most important innovation in recent years. We have taken repeated opportunities to point out in our columns the advantages of the gearing in the matter of accessibility and in the important element of reliability in the retention of the relative movement of its parts to the movement of the piston, in other words, its continuance of opening and shutting the valves correctly. In the final analysis, however, the real test of the gearing, as in all mechanism, is the record of service as observed and reported by those who are in a position to make observations that cannot be gainsaid.

In this latter regard we have taken the liberty during the summer months to inquire of engineers on some of the leading railroads as to their opinions of the merits of the Walschaerts valve gear after prolonged service, and we have everywhere been met with the statement that the gearing had given such excellent service that it had passed beyond the expectation of all who had the opportunity of testing its merits. This seems like extravagant praise, but it was easy to gather from the various sources of information at our disposal that the service of the valve gearing was of such a kind that it had already passed outside of the consideration of the engineers and others under whose supervision it had come. No reports, no complaints, is the highest praise that can be given to any part of the twentieth century locomotive, and that is the position which the Walschaerts valve gear has reached in its brief experience in America.

It is no part of our purpose to belittle the shifting link motion so long in use on American locomotives. On certain classes of engines it has done and is still doing excellent service. It has suffered from various causes, among which is an unavoidable liability to get slightly out of order, chiefly from the fact that the moving force is so far removed from the valve itself, that an increasing amount of lost motion is, under any condition, unavoidable. The movement having to pass through so many joints, each of them affected by variable forces, no lasting provision could possibly be made to retain the valve in its true position for any considerable length of time. From this organic weakness there grew both among engineers and machinists a spirit of rectifying, which in many instances was a mere meddling with the mechanism. The Walschaerts valve gear is fortunately free from offering the same temptation for this experimental work. The attachment of the valve rod and crosshead obviates the possibility of the slipping motion incidental to a link oscillating in a long arc, and the closely connected movement of the piston and valve in the Walschaerts

gearing renders the movement nearly absolute.

It may be noted that while the reports so far are of the most gratifying kind, there is still an absence of detailed reports in the matter of work accomplished in the various fields of locomotive service and also the comparative costs of fuel and lubrication which, no doubt, is accumulating in the hands of railroad officials, and in due time from these we will be able to gather more fully the comparative merits of the Walschaerts valve gear as applied to American locomotives.

### High Speed Gasolene Railroad Motors.

A press dispatch sent from Chicago early in August reads:

"On its first severe long distance test one of the new Union Pacific all-steel motor cars followed the fast Overland Limited, as a second section, more than 150 miles. In a third of this distance the motor gained on the Limited to such an extent that the car was held at a block signal six minutes.

"For the 153.6 miles covered by the test the speed made was 34 miles an hour. Meeting trains and other delays increased the time considerably above what the car could make on an open track. On the return trip from Grand Island to Omaha, though no speeding was attempted, the car made 36.3 miles an hour. The highest speed attained was 53 miles an hour.

"The gasolene motor car under test is known as No. 7, and is one of the latest turned out at the Union Pacific's Omaha shops. It is believed that branch line traffic, for which Mr. Harri-man originally suggested these cars, can be handled more quickly, efficiently and cheaply by this means than in any other way.

"The newest type of these cars is 55 ft. long, weighs 58,000 lbs., and seats seventy-five people. The side entrances and large circular windows are uncommon features, in addition to the usual comforts of a first-class passenger coach. When necessary the motor cars can haul a trailer for baggage, mail and express."

That was a striking performance, and indicates that gasolene motors may in the near future become rivals of the steam locomotive in the movement of trains and prove itself as efficient and economical in train service as the gas engine has proved itself as power for stationary industrial purposes. But considering that the object in building the gasolene driven cars for the Union Pacific was to provide cheap power for branch lines that traverse sparsely settled districts, we cannot help thinking that economy of operating has been sacrificed to display of design, luxurious furnishing and the capacity for high speed. There seems to be a mania

among the builders of automobiles to turn out vehicles capable of attaining tremendous speed, and the designers of the Union Pacific gasolene motor car seem to have been touched with the high speed contagion.

As the officials of many railroads are searching for a motor car suitable for operating branch lines at small expense, some of them may be inclined to secure cars similar to the Union Pacific flyer. To those entertaining such sentiments we would say, give the question further study and consideration. The Union Pacific gasolene motor car, as stated in the dispatch, weighs 58,000 lbs., which seems certainly heavy for service that ought not to entail speed of more than thirty miles an hour. The dead weight makes a heavy load for a gasolene engine.

### Nickel an Uncertain Material for Rails.

Among the many recommendations made to prevent rails from breaking is one advising the introduction of nickel steel, which would make a much stronger rail than the Bessemer steel from which practically all steel rails are rolled. This recommendation comes from prominent rail makers and is not lacking in cool assurance. There is no doubt that the market has been loaded for the last few years with inferior Bessemer steel rails that have been rolled from the whole blooms, the inferior top included, which used to be cut off when the demand for rails was not so urgent as it is to-day.

When vigorous protests were raised by railroad managers against the inferior steel which rail makers were working into rails, ordinary people would have supposed that the makers would return to the old time practice of using only good material, but instead of that they propose putting new burdens upon their customers in the form of enhanced prices.

It is doubtful if the expensive remedy proposed, would be satisfactory as a preventative of breakage. Nickel steel when new is a very strong material, but there is reason to believe that it deteriorates in service more rapidly than ordinary steel. If steel makers wish to raise their profits by inducing railroad companies to use nickel steel rails, they had better roll some rails of that material and have them placed under heavy traffic to demonstrate their wearing qualities.

It is a very significant fact that at the present time the Egyptian Minister of Instruction has decided that fifteen Egyptian students shall be sent every year to England to complete their education as doctors, lawyers, engineers and professors.

### Book Notice.

Development of the Locomotive Engine, by Angus Sinclair. A history of the growth of the locomotive from its most elementary form, showing the gradual steps made toward the developed engine, with biographical sketches of the eminent engineers and inventors who nursed it on its way to the perfected form of to-day. Many particulars are also given concerning railroad development. Published by the Angus Sinclair Publishing Co., 136 Liberty street, New York. 680 pages, profusely illustrated, and bound in half morocco. Price, \$5.00.

The railway engineering world will be pleased to hear that Mr. Sinclair has completed the great task that he set out to do more than thirty years ago. That the book more than meets the expectations of those who have seen advanced proofs of the pages is saying a great deal, because it has long been known that the accomplished author has been spending much time and labor on the work. The completed book is a monument to his industry and ability, and is altogether the most important contribution to railway engineering literature in the particular field which it covers. The great bulk of the work is entirely new, and a perusal of the storied pages opens up an ever widening vision that reflects an admirable phase of the human intellect in persisting in the more complete subjugation of the titanic forces of nature.

Beginning with the earliest attempts at harnessing steam, the narrative unfolds itself with the interesting grace of a romance. The entrancing story is epical in the greatness of events. The characters that follow each other in rapid succession are all heroic. There is an aptness and justness in the space given to the biographical parts of the work. The reader is never wearied with unimportant details. In the development of the locomotive a thousand busy hands have worked, and it has been left to Mr. Sinclair to point out the contribution made by each to the perfected mechanical marvel of to-day. He has brought to his work not only a mind stored with personal recollections of many of these gifted engineers who aided in the development of the locomotive, but his long experience as a writer has perfected him in the art of classifying the mass of material and presenting the salient features of the interesting subjects in their proper place and in the best possible light. In this latter regard Mr. Sinclair's work is in sharp contrast with that of the work of many eminent biographers, who are apt to overpraise their heroes. In Mr. Sinclair's book, while the surpassing work of James Watt is tersely pointed out, the merit of Newcomen's engine is frankly allowed, while just recognition is given to Trevethick, Hed-

ley and others of the early adapters of Watt's engine to locomotion, as well as to Stephenson, whose success as a promoter should not place him in the false position of a great inventor.

Passing over the familiar ground of the beginning of the work, we are led to the Genesis of American Railways, an important and interesting chapter, which ought to be read in the public schools. The connecting of the Atlantic Ocean with the western rivers follows, and the construction of the railways over which the grandly growing locomotives are pushing their way toward the setting sun fill many interesting pages that shed a flood of light on a great group of admirable characters, pioneer engineers, chivalrous adventurers, unsurpassed in song or story, some of them battling on through trial to triumph, others falling, soldier-like, in action, but whose deeds are fittingly commemorated in this notable book. The establishment of the machine shops where the first locomotives were built is described, and the original features in construction proceeding from these busy factories are full of interest, and, as in all else, the survival of the fittest blossoms into the colossal locomotive works at Philadelphia, Paterson, Schenectady and other places.

The method of dividing the descriptive portions of the work into geographical sections is finely illustrated in the chapters on railroad construction and locomotive building in New England. Typical Eastern men loom largely up in this most interesting section, prominent among which is William Mason, whose fine taste in beautifying the locomotive aided largely in reconciling the popular mind to the appearance of the iron horse. During this period a superior class of constructors was developed, and the name of Master Mechanics fittingly applied to them. Mr. Sinclair presents in his pages a number of these high-class workmen, fitting examples for the workmen of to-day. Indeed, the chapters dealing with the construction of the various leading railways are full of interest, and in passing along these great highways of traffic few would think of the individual self-sacrifice and the unwearied effort they represent. The actions of the various State legislatures are the subject of some caustic comment, and it is surprising to learn how much heart-breaking opposition the railroads have encountered from absurd legislative enactments.

Considerable portions of the book are taken up in the description of parts of the locomotive. The chapter on boilers is an excellent work in itself, as also is the chapter on draft appliances and spark arresters, while the portion devoted to the development of valves and valve motions shows how carefully the author has conned his subject, and there is no book on the subject of valve motions

published at the present time that gives at once such a comprehensive treatise as this portion of Mr. Sinclair's book does, accompanied as it is with fifty fine illustrations of the various devices that have been used, or are in use in moving the valves of locomotives.

We cannot refrain from calling special attention to the chapter on Freaks and Curiosities in locomotive construction. The author presents twenty-nine examples of these curiosities, with accompanying descriptions, and while most of them are fearfully and wonderfully made, there is an air of seriousness in the work that is very far from being akin to levity. One marvels at the ingenuity displayed, and while they look as absurd as Falstaff's soldiers, they form a characteristic collection that impresses themselves on the memory of the interested and amazed beholder, and it must be remembered that it is from the manifest errors in the construction of these engines that the accomplished mechanic has learned what should be avoided.

Safety devices, especially the Air Brake and Safety Valve, are treated in a clear and comprehensive manner. The development of these devices from crude and embryotic beginnings has kept pace with other improvements, and is treated in its historical relation to the growth of the locomotive. The book fittingly closes with a chapter on the locomotive of to-day, and while a fine panegyric is passed on the splendid engines that are the crowning triumph of twentieth century mechanism, the author combats the opinion held by the uninstructed that the locomotive engine has reached the limit of its possibilities, and assures us that the engine is still susceptible to much improvement on the lines of increased efficiency.

The book contains a finely characteristic portrait of the author, and among the numerous illustrations are the portraits of fifty or sixty eminent engineers and railway men. The book is in every way a very notable contribution to the literature of our time, and it is fortunate that Mr. Sinclair has found time in the course of a remarkably busy life to collect the materials and prepare a book that at once takes its proper place as the standard work on the development of the locomotive engine.

In conclusion it may be noted that the author shows a generous frankness in acknowledging the sources from which he has gathered much of his valuable information. There is a highly interesting chapter on the railway development in Canada from the pen of Mr. George Sherwood Hodgins, the well-known engineering writer. This contribution is of historical value and will be accepted as authoritative concerning the beginnings of railroad and locomotive construction in the Dominion.

C. L. W.

### Subaqueous Tunnel at Detroit.

The Michigan Central Railroad is the only one of the New York Central Lines in whose roadbed there is any serious break. The gap to which we refer is where the Detroit river forms the international boundary between Canada and the United States. The river where it separates Windsor on the Canadian side from the city of Detroit is perhaps three-quarters of a mile wide, and the connection is made by the use of large and powerful ferryboats.

The building of a railroad tunnel at this point is a serious undertaking, as the bed of the river is for the most part soft blue clay, and the vessel traffic up and down, when reckoned in tonnage, is about equal to that of the famous Suez Canal. The form of tunnel decided upon was that of twin tubes, and the method of construction devised by Mr. W. J. Wilgus, vice-president of the New York Central, may roughly be described as the "cut and cover" method as applied to tunnels under water. Mr. Wilgus at first proposed to dredge a ditch or channel across the bed of the river, fill it with concrete and then drive the tunnel through it. This would practically be equivalent to making rock and then boring it, and an easier method at once suggested itself to his mind.

The method thus evolved consists of

Our half-tone illustrations show sections of the tubes as they stand in the contractor's yard. Each section consists of a circular ring of  $\frac{3}{8}$ -in. steel plate,

In the mass of concrete forming these platforms are contained conduits for telephone, telegraph, signal, lighting and electric power cables, and the platforms

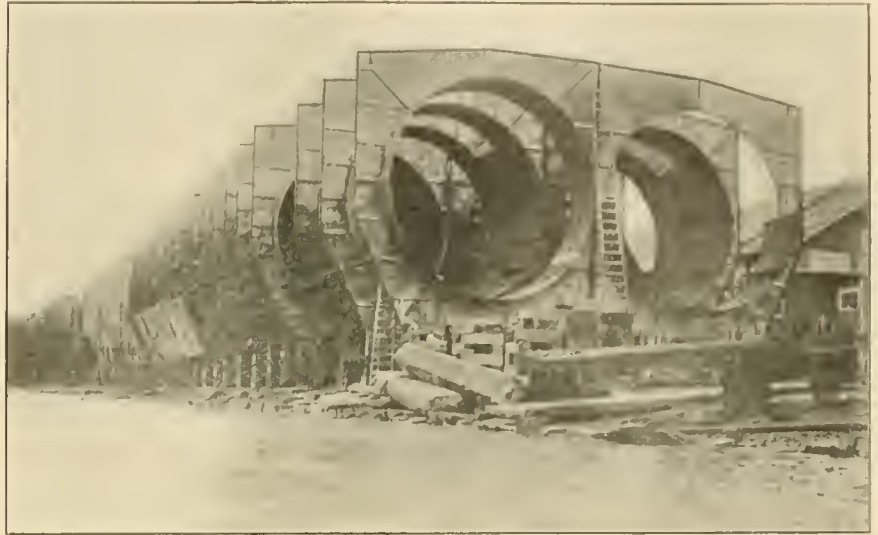

FRONT VIEW OF TUNNEL TUBES WITH CONNECTING DIAPHRAGMS.  
(Photo by Detroit News-Tribune.)

with a central fin or diaphragm all round it. These diaphragms are placed about 12 ft. apart, and serve to stiffen the tube, as well as support it on its bed of concrete. The sections of tube are 250 ft. long and are each 23 ft. 4 ins. in diameter,

provide space for workmen in the tunnels and a walk way for passengers in case of necessity.

The tunnel is, as we have said, composed of twin tubes of steel, and the subaqueous portion is 2,622 ft. in length. The roof of the tubes will be at no point less than about 41 ft. from the surface of the river. This is slightly more than the depth required by the navigation laws. On each of the shores the tubes connect with tunnels and open cuts, and through these, cars will be operated by electric locomotives. The work altogether will comprise an electric zone on each side and under the river about 23,000 ft. long. There is a double track entering an open cut at the Detroit end 1,540 ft. long, then through a land tunnel 2,129 ft. long. The subaqueous tube itself comes next, and at the Windsor side there is a land tunnel 3,192 ft., followed by an open cut 3,300 ft. long.

Our line cut illustration, for which we are indebted to Mr. Wilgus, gives an excellent idea of how the work is being carried on. In the far distance and nearing the Canadian shore is the dredge equipped with powerful clam-shell buckets excavating a trench or ditch across the bed of the river. This trench is about 48 ft. wide at the bottom, and about 32 ft. deep, with a slope of sides of  $\frac{1}{2}$  to 1, so that the width of the top of the ditch is between 50 and 60 ft. wide. All the material taken from the bed of the river is loaded on scows and taken away.

Behind the advancing dredges are the pile drivers. Their work consists of driving temporary piles in the bottom of the trench, upon which to locate the tubes prior to placing the concrete. There

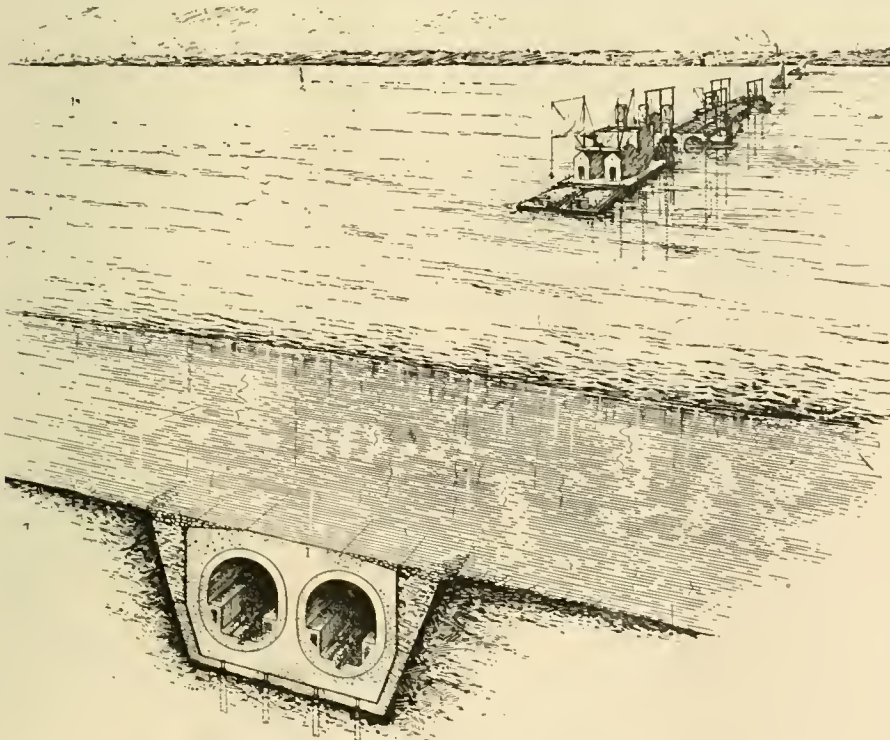

DETROIT RIVER TUNNEL, LOOKING TOWARD CANADA.

dredging a channel or ditch right across the bed of the river, laying sections of tube in the ditch, connecting them together when in place, filling around and over them with concrete, and then pumping out the water in each of the continuous tubes.

and have a lining of concrete 20 ins. thick, which gives a clear diameter of 20 ft. Each tube contains one track, and the height from top of rail to roof of tunnel is 18 ft. Concrete platforms 5 ft. 3 ins. above the rail and 3 ft. 10 $\frac{3}{8}$  ins. wide on top run along the sides of the tunnel.

are also two rows of temporary piles driven, one on each side of the trench. These are long ones, and come up above the surface of the water. They serve as guides and between them the tubes are placed before sinking, and these guide piles cause the tubes to go down and settle in the trench in the required direction. The guide piles are taken out after they have served their purpose.

In this condition the section is towed out into the stream, steered in between the row of guide piles and slowly sunk by allowing the air inside to escape, the final adjustment being made with the compressed air tanks, which are afterwards floated to the surface and used again. When in position on the bottom of the trench the last section is joined to the section already down. The

out any large amount of cement being washed away. The scow or barge used on the Detroit River work is about 135 ft. long by 35 ft. wide and is arranged with three of these tremies on one side, each with high leads similar to pile-driver leads. These are used for raising and lowering or moving the tremies. It is here that the use of the planking bolted to the edges of the diaphragms becomes apparent. Concrete made of one part cement, three of sand and six of broken stone is poured in between the tubes and the 3-in. planking. This concrete fills in between, under, over and around the tubes, and covers them to a depth of 4 ft. 6 ins., and is 3 ft. thick below them. Outside the planking the space between it and the sloping side of the trench is filled with sand and gravel and covered with loose stone. When the tubes are all finally bedded the wooden bulkheads at the end of each section are removed and the water pumped out.

This method of tunnel building has the advantage of being easier and quicker than driving the tubes through with pneumatic shields below the river bed. When using the shields in soft ground, as in this case, the bed of the river would probably have had to be covered with a blanket of clay, or the freezing process, such as has been carried on in the river tunnels at New York, would have had to be resorted to. In any case, a roof of about 15 ft. would require to be carried over the tubes if driven with shields in order to prevent air from inside blowing out into the water. The tubes so driven would require to pass 15 ft. below the lowest portion of or any hollow in the river bed. With the method adopted, the general contour of grades were thus secured. A very great deal of the work was done from the surface, and there is probably less danger involved. The grades on the Detroit-Windsor tunnel are 2 per cent. at the Detroit end and a 1.5 per cent. grade at the Windsor end. The fact that the grades have thus been reduced more than they could have been if the tunnel had

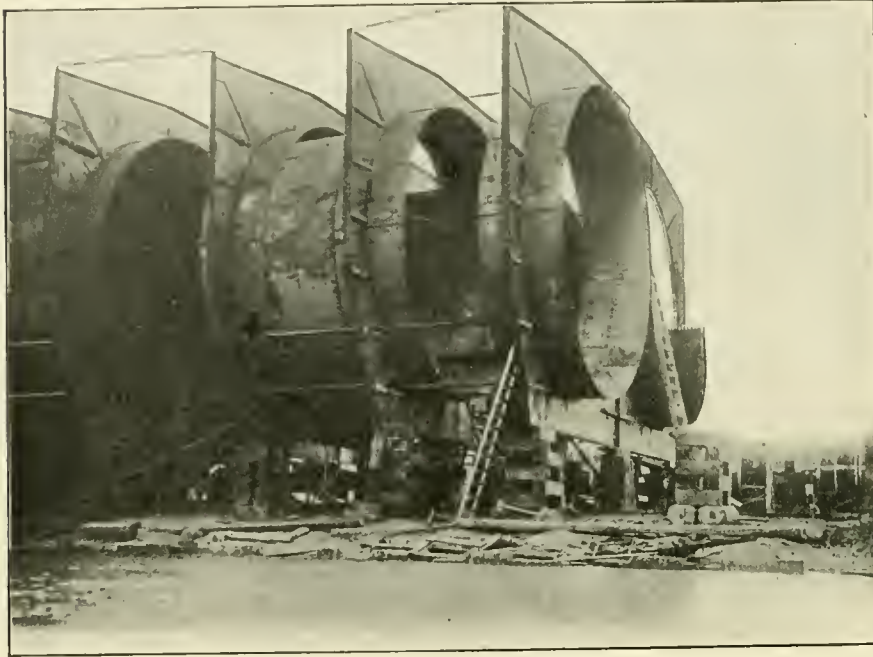

SIDE VIEW OF TUNNEL SECTIONS.  
(Photo by Detroit News-Tribune.)

The trench having been excavated, and the piles having been driven, the scows shown behind the pile drivers are those used for placing the tubes. These scows carry derricks, air machinery, divers' equipment, hoisting apparatus, etc. The tunnels, as we said, are steel tubes, made in sections with diaphragms or strong plate frames between them. The diaphragms hold the tubes in the same relative position to each other, with centres about 26 ft. apart. A section of tunnel about 250 ft. long containing two tubes and 23 diaphragms is made ready to float off on the river. This is done by blocking up each end of the twin tubes with bulkheads of wood. The tubes, therefore, enclose air. On the outer edges of the diaphragms, solid 3-in. planking is bolted, which adds to the buoyancy of the whole. The section when ready to float is like a huge vessel with wooden sides having steel ribs across holding the tubes. On top of the tubes and chained to them are four temporary floating cylinders, each about 10 ft. in diameter and 60 ft. long. These are filled with compressed air and, with the enclosed air of the main tubes and the planking along the outer edges of the diaphragms, make the whole section buoyant enough to float.

tubes shoulder in heavy rubber gaskets at the joints, in each side of which are partially cylindrical chambers. Into these chambers the best grade of cement grout is introduced. The joints are finally locked with heavy pins fitting into the river bed is followed, and easier corresponding sockets in the adjoining section, and securely bolted. The forward end of each of the tubes has a sleeve 17 ins. long, which is fitted over the end of the section previously sunk.

The next operation is filling in with concrete. This is done from a barge fitted with concrete mixers and a set of tremies which distribute concrete under and around the tubes. These tremies are long steel tubes and are usually made from 8 to 12 ins. in diameter, each with a hopper at the upper end. The tremie is dropped down so that the lower end rests on the ground or on the concrete which has already been placed. The tube is then filled with concrete from the top and is raised enough to allow the concrete to ooze out around the bottom of the lower end. The tube is moved over the mass so as to distribute the concrete. This material is constantly supplied to the hopper at the upper end, as fast as it runs out at the bottom. In this way the concrete is deposited under water with-

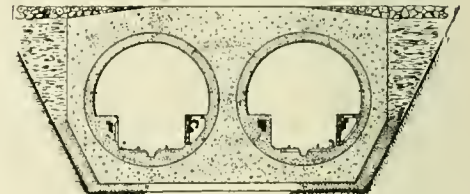

SECTION OF TUNNEL SHOWING TRENCH, FILLING, CONCRETE AND TUBES.

been driven below the river bed is a permanent economy which will make itself felt. As a matter of fact, this tunnel, as now constructed, is at one place about 8 ft. above the level of the bed of the river, while preserving the depth of water above it required by government regulations.



# Correspondence School

## Fourth Series—Questions and Answers.

91.—How do you block up or get to a side track with a broken engine truck wheel or axle?

A.—Assuming that this is a four-wheel truck, and that the front wheel or axle is broken, one of the ways that this emergency may be handled when short of heavy jacks is as follows: Chain the front of the engine truck up to the main frames of the engine as tightly as possible, then run the front drivers up on a wedge or old fish plate or other convenient object. This will raise the engine slightly and the chained up end of the truck will come up a little. Next block under each engine truck frame with a couple of ties or long blocking so as to hold the truck where you have got it. Move the engine ahead just enough to let the front drivers down on the rail, the long blocking under the truck will slide slightly, but if carefully done the truck will be kept up. Now tighten the chains by means of wedges, etc., to take up all the slack possible and run the leading and the second drivers up on wedges. The engine truck, at the chained up end, will come up a little more. Block it up tightly in that position, and come forward just enough to let the front drivers down on to the rail; this will give a little space between top of leading driving boxes and frame. Put a block in on top of the leading driving box each side and come off the wedges with the back drivers. This will leave the chained up end of the engine truck higher than the rail, and the engine truck should then be blocked on each side of the cradle and the truck plate so as to prevent side swinging, and the broken axle should be chained up to the engine truck frame so as to prevent it moving or falling down; a block put in under saddle and engine truck frame over the good wheel boxes will help to carry the weight and relieve some of the strain on the chain.

92.—In dealing with the Mogul type of locomotive with broken engine truck wheel or axle, what would you do?

A.—In this case the same general procedure as that outlined in answer No. 91 should be followed, only the whole engine truck must be chained up. It will help somewhat to hold back end of equalizer by block placed on top of equalizer and below the cylinder saddle. The engine must be run cautiously, as weight formerly borne by engine truck is now on leading drivers.

93.—With broken tender truck wheel or axle what would you do?

A.—If front wheel or axle of leading tender truck is broken and no jacks avail-

able, twist check or safety chains so as to take up all the slack. Put block at an angle between tie and tender frame and pull ahead a few inches so as to raise tender frame and carry truck up at disabled end, block truck and let tender frame down by backing off block; tighten safety chains and raise tender frame same way again if necessary. Put rail across tender frames or on water bottom, over shoveling plate and chain disabled end of truck to ends of rail. Chain broken axle up so it will not fall down or get in the way. If any other wheel or axle is broken in tender, the same general procedure may be followed, but rail or long stout stick of wood be put across tender top, over coping, but blocked along on top of tank plates, so as not to bear on the coping,

A.—The frame is fastened solid to the cylinders and cylinder saddle.

97.—Would you disconnect an engine for a broken guide?

A.—Yes, would disconnect main rod at butt end and shove it and the crosshead forward, block crosshead and centre valve and carry main rod in guide yoke clear of crank pin.

98.—How do you handle an engine if throttle sticks open, or dry pipe joint leaks so steam cannot be shut off from engine?

A.—Steam pressure may be reduced so that the engine can be handled by the reverse lever and the air brake.

99.—What will you do if throttle is disconnected and remains shut?

A.—Steam pressure may be reduced



GREAT INDIAN PENINSULA EXPRESS TRAIN LEAVING NERAL AT JUNCTION WITH MATHERAN RAILWAY.

and chain defective end of truck on each side to overhanging end of rail block over good boxes and under frame so as to relieve strain on chain. If check chain clevises are suitable, chain to them.

94.—Is it necessary to take down the main rod if frame is broken between the cylinder and forward driving box?

A.—Yes, take down main rod on the defective side of the engine.

95.—Would you take down either rod if frame is broken between forward and back driving boxes?

A.—If both frame bars are broken between driving boxes it is right to take down both side rods. If only one frame bar is broken it is likely to be the lower one, close to the pedestal binder and engine can be run home carefully with side rods up.

96.—Where is the frame fastened solid to the other part of engine?

and engine towed in without disconnecting anything.

100.—If a crank pin brass gets hot so the babbitt melts, would you cool it off with water before all the babbitt comes out?

A.—No, get all the melted babbitt off the pin, as the sudden application of cold water is liable to make some of it stick to the pin. See that the oil way from cup is clear to the pin and lubricate freely. If brasses can be loosened by slacking key, do so, and with ample lubrication it will not be necessary to cool with water.

101.—Can you take out a tender truck brass and replace it with a new one? How?

A.—Yes. I should take the weight of the tender on a jack and then jack up the axle box until the wedge comes below the lugs in the roof of the box and then pull out brass and wedge. If a large jack is not available or time presses it is possible

to jack up the end of the arch-bars of the truck and take out the brass.

102.—An engine truck brass?

A.—This depends upon the construction of box. If the brass is held in place by a boss in the centre, fitting into a cavity of the box, take weight of engine at the front end and jack up the box until boss drops out of cavity.

103.—How often do you examine the ash-pan, grates and dampers?

A.—At the end of every trip.

104.—What are your duties after cutting off from train at the end of trip?

A.—Answer according to rule of your own road.

105.—What are your duties in case of wrecks when your engine is off the track?

A.—It is my duty to know that train is protected and to notify the train dispatcher by wire of the accident and the extent of the trouble as far as I can tell. If the engine cannot be put on the track without the help of the wrecking crew, it is my duty to keep the engine in steam, if possible, so as to be able to assist. I should make such other arrangements as occasion requires.

106.—Do you understand the principle on which an injector works?

A.—The principle on which an injector works is that when a jet of steam at high velocity is combined in a suitable way with a body of water moving at a lower velocity, the combined water and steam (now forming hot water) is able to move along the delivery pipe and unseat the check valve against boiler pressure and enter the boiler. It is a suitable combination of a heavy body (water) moving at slow speed with a light body (steam) moving at high velocity, which enables the injector to act.

107.—What are the different builds of injectors on this road?

A.—Answer according to the equipment of your road.

108.—What is the combining tube?

A.—The combining tube is the one in the injector where the jet of steam is combined with the water.

109.—If sand or dirt gets into the passages, will the injector work?

A.—No, the injector is a very delicately proportioned instrument, and if its passages are clogged or obstructed it fails to work.

110.—In case an injector will not work when it has always been reliable before, where would you look for the trouble in the first place?

A.—First look to see if there is water in the tank, then in the water connection between engine and tender I should carefully examine hose and strainer.

111.—If it will not prime at all?

A.—Probably short of water or hose or strainer choked up.

112.—If it primes, and breaks when opened wide, where would you expect to find the trouble?

A.—The water supply is probably insufficient or joints may be drawing air.

113.—When boiler check sticks up or leaks back as water comes from the boiler, how do you remedy it?

A.—Open the overflow of the injector, and endeavor to reseal the check valve by working the spindle of the check valve and starting and stopping the injector several times in succession so as to endeavor to wash off any dirt or grit that may be on the seat of the check valve.

114.—Is there more than one check valve between the injector and boiler?

A.—Answer according to the equipment of your own road.

### Elements of Physical Science.

#### V.—CENTRE OF GRAVITY.

The centre of gravity is a point in any body about which all its parts are balanced. It is the centre of weight and must be distinguished from the centre of magnitude or of motion. The centre of magnitude is a point equally distant from its opposite sides. The centre of motion in a revolving body is a point which remains at rest, while all the other points of the surface are in motion. The centre of gravity may coincide with the centre of magnitude and it may not. If a wheel is of uniform weight and density the centres of magnitude and of gravity will be the same, but if the wheel is heavier on one part, the centres will vary in a corresponding ratio.

The point in a body in which the centre of gravity is situated, may be found, in many cases, by balancing it on a point. In bodies of regular shape and density lines drawn from opposite corners will bisect each other at the centre of gravity. Bodies that are irregular in shape and that may be suspended so that they can move freely, may have the centre of gravity located by dropping a plumb line from the point of suspension, and mark the direction of the line on the surface of the body. The body can then be moved to another position and another line drawn when the plumb line is applied, as before. The bisecting point will be the centre of gravity.

#### STABILITY OF BODIES.

The lowest side of any body is called the base. When the line of direction passing through the centre of gravity falls within the base, a body stands; when the line passes outside the base, the body falls. Of different bodies of the same height, that which has the broadest base is the hardest to overturn, because its line of direction must be moved the farthest to fall outside of its base. The truth of this principle has an enduring proof in the stability of the pyramids. No other structures fashioned by human hands have stood the blows of circumstances for so long a time.

A ball of uniform density has its centre of gravity at its centre of magnitude. When such a ball rests on a level surface,

the line of direction passes through the point of support, and the ball remains stationary. When a ball is placed on a sloping surface, the line of direction falls outside of the base, and the ball begins to roll. A square block placed on the same surface, maintains its position because its centre of gravity falls within the base. Of bodies with bases equally large the lowest is the hardest to overturn, because its line of direction is least liable to fall outside of its base. Under these conditions, the lower the centre of gravity, the more stable a body is. It will be observed that in packing goods in wagons or cars or vessels, the heaviest are placed lowest.

It may be noted that while there are no exceptions to the general law relating to bodies falling, where the line of direction of the centre of gravity falls outside, some bodies can be so constructed as to resist the force of gravity. The most notable illustration is that of the leaning tower of Pisa, with a height of 150 feet and leaning to such a degree that the top of the tower overhangs its base over 12 feet. In spite of this fact it has stood for centuries. The centre of gravity is much lower than it appears to be from the fact that heavy materials have been used in the bottom of the structure, the lower stories being of heavy volcanic rock, the middle stories of brick, and the upper stories of an exceedingly light porous stone. If the same material had been used throughout, the tower could not have stood.

#### ROTARY MOTION.

Rotary motion has the quality of keeping a body from falling, even when its line of direction falls outside of its base. This will readily be observed in the spinning of tops, which retain their equilibrium while in motion, but which fall immediately on becoming stationary. Other bodies not so evenly balanced can readily be kept from falling even if the centre of gravity is not over the point of support, but if the body is constantly moving round the axis of motion, before it has time to fall in consequence of being on one side of its axis, it reaches the other side, and thus counteracts the previous impulse. The higher speed has the effect of steadying more completely the moving body, and as the motion slackens, the body gradually oscillates more and more, and finally falls.

#### EQUILIBRIUM.

The centre of gravity in all bodies tends to get to the lowest possible point. Solid bodies resting on a surface in such a way that their centres of gravity are lower than they would be in any other position, are said to be in stable equilibrium. If the centre of gravity could be brought lower by placing them differently, they are said to be in unstable equilibrium. Thus an oval resting on its longest side would be in stable equilibrium; while standing on either end it would be said to be in unstable equilibrium.

## Questions Answered

### DIRECT AND INDIRECT VALVE MOTION.

(79) M. C. L., Mexico, writes: We have some engines here with valve motion arranged as follows: The go-ahead eccentric follows the main pin. The transmission bar connects with the link-block supported by a hanger, the front end connected to bottom rocker arm, and top rocker arm to valve stem. Is this engine direct or indirect?—A. We would imagine from your description that the engine has indirect valve motion. The rule for determining whether valve motion is direct or indirect is briefly this: If when the eccentric rod moves forward, the valve moves back, the motion is indirect. If a forward thrust of the eccentric-rod produces a forward movement of the valve, the motion is direct. It does not matter whether a transmission bar is used or what the style of the intermediate connections may be.

### WHAT IS A "CONSOLIDATION" ENGINE?

(80) J. J. C., Roanoke, Va., writes: I would like to have you settle a controversy by answering through the columns of your valuable journal the question, What constitutes a consolidated locomotive engine?—A. First of all let us say that the name of the class of engine to which you refer is the consolidation type, not "consolidated." A consolidation engine is a 2-8-0 engine, that is, one with a two-wheel pony truck and eight driving wheels. An example of this type may be seen on page 368 of our August issue. The name of the type was derived from the fact that the first of its class was turned out of the shops of the Lehigh Valley Railroad just after that road had effected a consolidation with another corporation, and this first engine was simply called the "Consolidation" in memory of that event. The name of this particular engine soon became the name of the whole class of 2-8-0 engines.

### BALANCED SLIDE VALVE.

(81) B. W. T., Australia, asks: When altering a locomotive with the ordinary D-slide valve into a balanced valve what percentage of weight do you take off, and how do you figure out the same?—A. Suppose the outside measurements of the entire top of the valve are 21 ins. by 10 ins. This would give an area of 210 sq. ins., which with a steam pressure of 140 lbs. per sq. in. would equal 29,400 lbs. pressure on the top of the valve. Now if the valve is balanced by the usual method of strips resting on springs and sliding on the under face of the steam chest lid or on the balance plate and supposing the measurements of the space enclosed by the strips are 20 ins. by 9 ins., this would give an area of 180 sq. ins., which would relieve the pressure on the top of

the valve to the amount of 25,200 lbs. The rule recommended by the committee of the American Railway Master Mechanics' Association for balancing either the ordinary D-slide or the Allen valve is, Take the area of the exhaust port, plus the area of two bridges, plus the area of one steam port. These are added together equal the area of balance. This area is measured from the inside edges of the balance strips. The rule gives roughly a balance of from about 55 to 58 per cent.

### REDUCTION OF BRAKE PRESSURE.

(82) G. H. P., Willow Glen, N. Y., writes: (1) By reducing the brake pipe pressure 5 lbs., how many pounds of air will go from the auxiliary reservoir to the brake cylinders?—A. Five



TWISTED PORTION OF SECOND SPAN OF AVOCA BRIDGE, SOUTH AFRICA.

pounds of air will go from auxiliary reservoir to brake cylinder, which would result in a brake cylinder pressure of about 8 lbs., with an 8-in. piston travel.

### RETAINING VALVE.

(2) How much pressure is retained when using handle of retaining valve in high pressure position?—A. When the retaining valve is in use there is a pressure of 15 lbs. retained in the brake cylinder, providing there is more than 15 lbs. in the brake cylinder at the time the brakes are released. Fifteen pounds is maximum standard pressure retained.

### EXHAUST PRESSURE.

(83) B. W. T., Australia, writes: When working a locomotive at 50 per cent. "cut-off" with a boiler pressure of 175 lbs., what would be the pressure per square inch in the exhaust cavity of the slide valve? Kindly explain how to find such pressure with varying cut-

off. A. The pressure of steam in the cylinder at the moment of exhaust can readily be ascertained by the use of the indicator, an instrument which is connected to the cylinder by a pipe so that the same pressure acts on the indicator spring as exists in the cylinder.

### EFFECTS OF MUD-BURN.

(84) J. B. E., Baltimore, Md., asks: What are the physical and chemical changes which take place when the sheets of a firebox become mud-burned?—A. Similar effects are produced in iron which has been overheated in the fire. It is probable that oxygen is to some extent absorbed by the plate.

### NEUTRAL POSITION OF BRAKE VALVE.

(85) B. W. T., Australia, writes: A train of 40 vehicles (or less) fitted with standard quick action brake apparatus and engine fitted with equalizing discharge valve No. 65, a simple feed valve applies the brake by making a 10-lb. reduction and returns brake handle to neutral position. When so applied, if one of the release valves on vehicles reservoir are opened, can this release valve be held open long enough to exhaust into the atmosphere all the air from all the brake parts of the 40 vehicles, leaving only the main reservoir of engine charged up with pump working?—A. If lap position is meant by neutral position, there is no air admitted to brake pipe in the lap position, and as the release valve is opened on auxiliary reservoir of one vehicle the pressure of air in that reservoir would be reduced below that in the brake pipe, which would result in the triple valve on that vehicle going to release and recharging position. In release and recharging position air from the brake pipe flows through the triple valve into the auxiliary reservoir, and since the release valve on this reservoir would be open the air would escape to atmosphere, which action would continue until all of the air from the brake pipe had exhausted, leaving the main reservoir and connections charged. However, this further reduction of brake pipe pressure caused by the opened release valve would apply the brakes with still greater force on the remaining vehicles in train. There would be air in the auxiliary reservoirs and brake cylinders of the remaining vehicles.

### DIRECT AND INDIRECT ENGINE, ETC.

(86) E. V. S., McCay's, Tenn., asks: (1) What is the difference between a direct and an indirect engine?—A. A direct engine is an engine where the piston rod acts directly on the driving shaft by the intervention of a single rod as in the case of a locomotive. An indirect engine is so called when an intervening beam, such as is used on river steamers, forms part of the engine. Direct and indirect valve motions

are explained in answer to Question No. 79.

(2) What is the difference between a plain valve and a balanced valve?—A. A plain valve is a valve where the full steam pressure is exerted on the exposed surface of the top of the valve. A balanced valve is so called from the devices that are used to reduce the steam pressure on the top of the valve. This is done by enclosing a portion of the upper surface of the valve, usually with four strips, resting on springs and sliding on a parallel face attached to the under side of the steam chest cover. This prevents the steam from exerting its pressure on the entire surface of the valve and reduces friction.

(3) What is a locomotive?—A. A self-propelling wheel carriage, especially one which bears a steam boiler and one or more steam engines which communicate motion to the wheels and thus propel the carriage.

(4) What should be done in case of a broken intermediate equalizer?—A. A description of the engine is necessary to give full directions, but in the breaking of equalizing beams it is well to remove the broken pieces and put blocks of hard wood between the top of the driving box and underside of the frames. This transfers the weight of the engine directly from frame to axle boxes and the next equalizer

The valve has a supplementary steam passage cast above the exhaust cavity. The valve and seat are so arranged that, as soon as the outside edge of the valve begins to open the steam port, the supplementary passage also begins receiving steam, thereby giving a double opening for the admission of steam. As the travel of the valve is always short when an engine is running at high speed, the advantage of the double opening is evident, because it admits the steam promptly at the be-

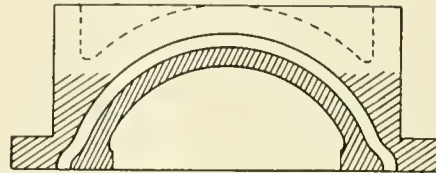

ORIGINAL FORM OF ALLEN VALVE.

ginning of the stroke, and maintains a full pressure on the piston till the point of cut-off. The general effect on the smaller class of locomotives was that the engine could take a train along, cutting off at 6 ins. with the Allen valve, when with the ordinary valve the links would require to be dropped to 8 or 9 ins. Many railway men claimed that a saving of coal amounting to seven per cent. could be effected by the use of the Allen valve.

our illustration. The girder is made with 7-16 in. webs, and double plates top and bottom  $\frac{3}{4}$  in. thick by 14 ins. wide fastened by 6 x 4 x  $\frac{3}{4}$  in. angles. These girders are spaced 7 ft. 10 in. centres, and are united by strong cross bracing at each end, leaving a well in the centre of the car. The main girders are supported upon two smaller girders which rest upon the centres of two eight-wheel trucks at each end. The car is thus carried on thirty-two wheels, or sixteen axles, and it is equipped with air brakes. Two 8-in. king bolts hold the main bridge girder, as it may be called, to the two girders which rest upon the trucks.

The car, over couplers, is 103 ft. 10 $\frac{1}{2}$  ins. The main girder is 66 ft. 10 ins. long. Each truck has a wheel base 12 ft. 9 ins., and the arrangement of two separate trucks at each end permits the car to curve readily, though on short curves the body of the car must necessarily have considerable side movement away from the centre line of the track.

The open well in the centre of the car is about 24 ft. long, and the load is carried, as occasion requires, either on the top of the main girders or upon I-beams, which cross between the girders on the level of the lower flange, against which they are bolted by four



SPECIAL ONE HUNDRED-AND-FIFTY TON STEEL FREIGHT CAR.

which is in good condition must be held in place with a block of wood or a nut placed on top of the frame and below the end of the equalizer next to the good spring.

#### The Allen Valve.

The introduction of the piston valve into the later class of locomotives, and the extending of the length of steam ports on those engines where the D-Slide valve is still used have somewhat overshadowed the merits of the Allen valve, which was looked upon as a very marked improvement in last century practice.

#### One Hundred-and-Fifty Ton Car.

In 1902 the Bethlehem Steel Company were confronted with the problem of the transportation of large castings and forgings in single parts for especially heavy machinery, and for the carriage of which the railroads were unable to furnish suitable cars.

In order to fulfill contracts, a car was built in their works at South Bethlehem, Pa., in 1903. The weight of the car complete is 196,420 lbs., and it has a capacity of 300,000 lbs.

The car itself consists of a pair of plate girders 6 ft. deep at the centre and tapering both ways, as shown in

bolts, two to each girder, passing up along the sides of the girders and through heavy steel caps on the top flange of each girder.

This car has proved its value in that it has transported various very heavy pieces of machinery. Some of the weights carried have been: One 12,000 ton armor plate press, the heaviest single shipment, weighing 277,000 lbs. One hydraulic flanging press for the Baltimore & Ohio Railroad, the heaviest single casting of which weighed 123,300 lbs. One 5,000-ton hydraulic press, the heaviest single casting of which weighed 252,010 lbs.

# Air Brake Department

## Duplex Compression.

The steam is used but once in this pump, and the steam piston of one cylinder actuates the steam valve, which distributes the steam in the opposite cylinder and vice versa.

From our illustration it will be seen that the steam valves, which are located in the lower portion of the pump, are fastened between two shoulders in the reversing rods, therefore any movement given the reversing rods by the steam pistons will move the steam valves the same. It will also be seen that the steam valves and ports in their seats are similar to those of a locomotive. We will call the steam pistons and cylinders high and low pressure, according to the air cylinders opposite them, the low pressure air cylinder being 12 ins. in diameter and the high pressure cylinder is 8 ins. in diameter. Referring to the figures on the steam valves, valve No. 1 is actuated by the high pressure piston and admits and exhausts steam to and from the low pressure cylinder, and valve No. 2 is actuated by the low pressure piston and admits and exhausts steam to and from the high pressure cylinder.

When steam is admitted to the pump it flows past valve No. 1 through the low pressure cylinder lower admission port under the low pressure piston forcing it upward; as this piston nearly completes its stroke the button on the end of the reversing rod is engaged by the reversing plate on the piston and moves it upward with valve No. 2 until valve No. 2 uncovers the lower admission port to the high pressure cylinder, then steam passes through this port under the high pressure piston, forcing it upward. As this piston nearly completes its stroke it moves valve No. 1, the same as described for the low pressure piston and valve No. 2, upward until it uncovers the upper admission port to the low pressure cylinder, when steam will enter on top of the low pressure piston, forcing it downward. As this piston nears the end of its stroke the reversing plate engages the shoulder on the reversing rod, moving it and valve No. 2 downward until valve No. 2 uncovers the upper admission port to the high pressure cylinder, and steam enters on top of the high pressure piston, forcing it downward. As this piston nears the end of its stroke it moves valve No. 1, as described for the low pressure pis-

ton and valve No. 2, downward until it uncovers the lower admission port to the low pressure cylinder, when the same operations are repeated.

The exhaust steam, as these pistons make their strokes, passes through the admission ports through the cavity in the steam valves, then exhaust port through the exhaust pipe to the atmosphere.

When the low pressure air piston makes an upward stroke the free air in front of it passes by the upper intermediate discharge valves into the high pressure cylinder. The high pressure

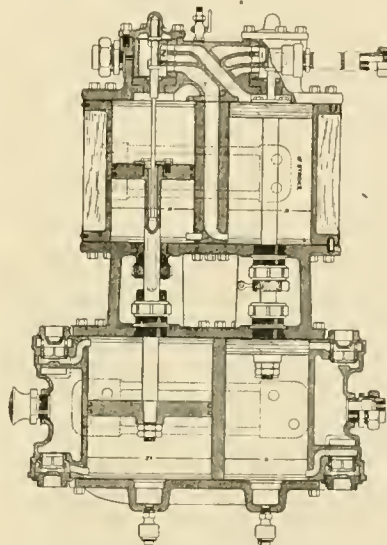

DUPLEX PUMP.

piston now makes an upward stroke, while the low pressure piston remains stationary at the top of the low pressure cylinder, and forces the high pressure cylinder of air, which has a pressure of about 45 lbs., past the final discharge valve into the main reservoir. As the low pressure piston made its upward stroke the low pressure cylinder was filled with free air, to be compressed into the high pressure cylinder as it makes its downward stroke, and as the high pressure piston also made its upward stroke the high pressure cylinder was filled with free air. The high pressure cylinder inlet and intermediate valves are not shown in the illustration.

Reading is to the mind what exercise is to the body, as by the one health is preserved, strengthened, invigorated; by the other, virtue (which is the health of the mind) is kept alive, cherished, and confirmed.—*Steel*.

## Brake Test in Round House.

A very reliable and interesting method of testing the air brake apparatus on locomotives is being successfully carried on in some engine houses at present. A reservoir, or series of reservoirs, in capacity equal to that of a forty, fifty or sixty-car train, whichever is common with the road using this method, is located at some desirable place in the engine house, from which a main pipe is run around the engine house, and from this main pipe branch pipes are run to the stalls that the brake pipe of the engine to be tested may be connected with the reservoirs. After the brake pipe has been cut in the pump is started and the time required for the pump to raise the desired pressure will correspond with the time it will require to pump up a train.

From this test reasonable time limits can be placed upon pumps of different capacities for charging a train, and when they do not come up to this requirement the pump can be changed before it has delayed trains upon the road.

Since the brake pipe in this method has the volume of a long train, a more accurate test can be made of the engineer's brake valve and slide valve feed valve or excess pressure valve, whichever valve is used. For instance, the lower body gasket in the engineer's brake valve is defective and allows air to leak from the brake pipe into chamber D, and feed this chamber as fast as the preliminary exhaust port could exhaust the air as in service position. With an engine alone the small volume of brake pipe pressure would be reduced enough to apply the brakes on the engine, but where the brake pipe has a greater volume the brakes would not apply even on the engine.

With this method a slight leakage in the brake pipe can be created which would show up a sticky or lazy slide valve feed valve, or excess pressure, that might be overlooked without the larger volume in the brake pipe.

There are a number of advantages in this method of testing which will manifest themselves by its use.

## Why Did Brakes Fail to Apply?

Editor:

I have handled several cases recently where solid air trains have parted and the air brakes failed to apply on the front portion of the train and for the benefit of the readers of this paper, as well as

information for myself, I would thank you to explain why the brakes failed to stop the front portion of train. I will explain the last case I handled in detail.

A freight train, consisting of 50 loaded coal cars, 3,500 tons. Engine had  $9\frac{1}{2}$  inch air pump. Main reservoir, 65,000 cubic ins. All Westinghouse equipment, including caboose, which was piped.

While descending a grade (70 ft. to the mile) at a speed of 18 or 20 miles per hour, the engineer attempted to make a service application of the brakes, when all brakes worked quick action causing such a shock to the rear of the train as to detach the caboose from train, knocking the conductor out of the cupola and slightly injuring him. When he had recovered from the shock he discovered that the caboose was detached from the train and was following the train some three or four car lengths from the rear car. He let the caboose follow and recoupled to train about  $\frac{1}{2}$  of a mile from the point at which it became detached. After coupling the caboose he closed the angle cock on the rear car and proceeded on down the grade until stopped by an automatic block signal, where the engineer made the stop with a service application of the brakes. At this point, a defective triple, which caused the quick action, was located and cut out. At the investigation the engineer stated that when he attempted to apply the brakes at the point where the caboose broke off that his brake valve service exhaust closed, and having had trouble with a defective triple in this train he immediately placed the brake valve handle in release position to keep the train from stopping, and that he knew nothing of the train line being open on the rear of train until told by the conductor.

I will be glad to have you explain through the columns of your valuable paper why the brakes failed to stop this train with the angle cock open on the rear.

C. M. KIDD,

Gen'l Air Brake Inspector.

*Roanoke, Virginia.*

#### Driver Brakes and Other Matters.

Editor:

The driver brakes on locomotives, both in freight and passenger service, are receiving more attention at present than they have been in the past, yet there is considerable room for improvement. A careful inspection of their condition, and to note the number of wrongly used triple valves and auxiliary reservoirs, will convince an air brake man that the driver brake is not being maintained as it should be.

Some air brake repairmen seem to be utterly unable to distinguish the difference between the F 46 and H 24 triple valves, in spite of the fact that the catalogue plate number is cast in raised letters on the body of both

valves; therefore, it is not surprising that they cannot remember the size of the auxiliary reservoir, which is always 2 ins. larger than the brake cylinder in diameter.

However, this wrongly used equipment is mostly due to the lack of material with which to make repairs, and the repairmen are compelled to replace broken or missing parts with something, regardless of size or style.

Probably 50 per cent. of the engines running in freight service have a defective driver brake. In many cases the engineer or inspector will test the brake cylinders and pipe connections with a torch, note that the piston travel is correct and decide that the brake is all right, where, if an air gauge were attached to the cylinder, it would show that the hand will fall from fifty to ten or fifteen lbs. in a very few seconds and remain there for a considerable length of time, showing no leakage.

The importance of a good driver brake has been dwelt on in these columns at various times. It has been shown that the braked weight of a heavy freight engine is equal to that of about five large capacity freight cars.

An inferior driver brake is not only annoying in heavy grade work, but it is dangerous, and the damage done to a train amounts to many times the cost of its proper maintenance. The intense heat of a locomotive has a tendency to dry out the packing leathers and joints and start leaks. The jar and pound of the engine will start pipe joints to leaking. The leaks are stopped from time to time, but will start again, and where an auxiliary reservoir is used to store a supply of compressed air for the operation of the brake, the leaks quickly destroy the braking power.

The distributing valve, when used, overcomes this trouble entirely, although it should not be considered an excuse for leaky pipe joints and packing leathers. This valve can be applied to an engine in a very short time, the main reservoir, brake pipe and brake cylinder connections made, the connection to the application chamber plugged, and can be operated with the G 6 brake valve.

The tender brake can be operated from the distributing valve by the addition of one piece of pipe and a hose, and if it is desired to leave the triple valve and auxiliary reservoir on the tender to keep it interchangeable it can be done by the addition of the straight air brake double-seated check valve placed between the triple valve and brake cylinder, with the pipe from the distributing valve connected to the straight air side, and the triple valve can be operated in conjunction with the distributing valve or cut-out.

Of course, the entire E. T. equip-

ment should be used, and it is more economical in every way.

At a conservative estimate, and due principally to hard handling, the G 6 brake valve will require cleaning four or five times to once for the H 5 brake valve, and owing to improvement in the construction of the H 5 brake valve, its rotary valve and seat will require facing off and grinding once, while a G 6 valve, in the same class of service, will be ground three or four times.

The economy in the use of the H 5 valve is apparent, as one-eighth of an inch removed from the wearing surface of the valve and seat in the G 6 valve is all that is permissible.

Under the tender there is no comparison between the two brakes, as it is all in favor of the E. T. brake.

There is no cost of cleaning and repairs to triple valves, and this is quite an item, as the tender triple catches most of the dirt and scale in the brake pipe and more or less moisture which is thrown into the brake cylinder during emergency applications.

Above all, there are no detentions due to defective triple valve or broken cross-over pipe, and no auxiliary reservoir to be eaten up by rust, which requires about half a day's time to renew.

The work of the air pump is more evenly distributed. During the application of the brake the air pump restores in the main reservoir the air that is expanded into the driver and tender brake cylinders, and in the release the volume from the main reservoir is all used to release and recharge the train, instead of a considerable portion being used to recharge two large auxiliary reservoirs on the engine and tender, the combined capacity of which is equal to about seven of the eight in freight auxiliaries.

This feature allows the pump more time in which to compress a given amount of air, and in a measure reduces the liability of the pump becoming overheated, and it is a well known fact that an overheated air pump is the worst disorder that the air brake can have. It not only reduces the capacity of the pump, but excessive heat ruins the air valve packing rings and air cylinders and scatters hot and burning oil throughout the entire air brake system, and in a few days all the different valves are gummed up and out of order.

The E. T. equipment and quick service triple valves should double the length of time the pump can run without being overhauled and consequently reduce the cost of repairs at least 50 per cent. Where four men are employed to keep up the repairs to the standard Westinghouse brake, two men should be able to do it with the E. T. equipment.

G. W. KIEHM.

*Washington, D. C.*

# Electrical Department

## Electricity in Railroad Shops.

Almost every railroad shop consists of a number of different sections, such as the machine shop, wood working shop, blacksmith shop, boiler shop, etc., each of which is usually housed in a separate building and these buildings scattered over a considerable area. Each of these various sections usually requires a certain number of power driven tools. To supply power for these by any purely mechanical means is an awkward proposition which requires either a multitude of shafts, belts and rope drives, in case a central power plant is used, two or more entirely separate boiler and engine plants in case the area covered by the building is large, or a number of small engines all taking steam from a common set of boilers. All of these methods are inflexible and uneconomical. By the use of electricity, however, the problem can be very satisfactorily solved, and aside from the general matters of increased flexibility and economy in the distribution of power, a number of other advantages leading to increased output may be secured.

In the use of electric power under such circumstances the three principal points to be considered are, first, the generation of the current; second, its transmission to the various buildings, and third, its utilization at the various tools to be driven.

Power may be generated either as direct current or as alternating current and each has certain advantages. In the case of any particular shop, therefore, the relative advantages and disadvantages of the two kinds of current with respect to the local conditions must be carefully weighed before a choice is made. Alternating current can be transmitted over long distances much more easily than direct current, and alternating current motors are somewhat simpler and more rugged than direct current ones. Direct current motors, however, are much more flexible in regard to speed control than alternating current ones, and where it is desired to gear motors directly to certain tools and vary the speed of the tool by varying the speed of the motor, direct current motors must be used. Either kind of current may be transformed into the other with reasonable readiness and economy, however, so that where circumstances warrant it both kinds of current may be employed, either two kinds of generators being

used or the generators being designed for the particular kind of current that is most used and a part of this current being transformed into the other kind.

If direct current is used, a voltage of 250 is generally employed and the entire system from generators to motors operated at this voltage. If alternating current is used, it is commonly generated and distributed at a voltage of 2,300 and then transformed in each building to a lower voltage for use at the motors.

In applying electric motors for driv-

ing the tools a compromise between the two plans is ordinarily made, and small tools and those of a character which require but little speed variation are usually grouped together on short lengths of line shafting, while the larger and more important tools are equipped with individual motors. A typical example of this is in the shops of the Erie R. R. at Hornell, N. Y., where out of thirty-one motors used for driving shop machinery, twelve are connected to line shafts, while the remainder are used for driving individual tools.

Electric motors are adapted not only for operating machine tools; they have equal advantages for the operation of cranes, turn tables, transfer tables,

control must be had by changing belts and similar troublesome devices, tools will often be operated much below their full capacity. In certain sorts of operations a tool may even be speeded up on the back stroke and slowed down again on the working one, by simply a slight motion of a single small handle.

This feature of the individual electric drive, while important in any shop, is of particular importance in a railroad shop where a given tool is frequently used for many different kinds of work.

In equipping a shop with electric mo-

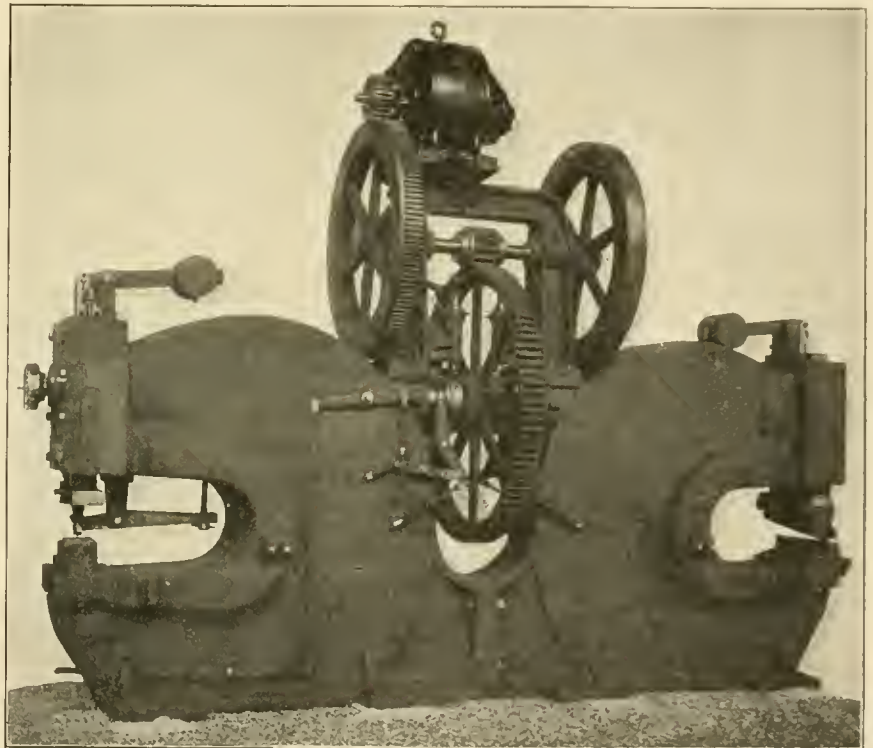

PUNCH AND SHEARS ELECTRICALLY DRIVEN.

ing the tools two different plans may be followed. A single motor may drive a group of tools by means of a line shaft, in the ordinary way, or a motor may be connected directly to each individual tool. The former plan is usually much cheaper to install, while the latter possesses the advantage that no power is lost in driving belts and shafting, and complete control of the tool may be had by controlling the motor. The ease and readiness with which the speed of a motor may be controlled over a wide range gives this method a great advantage for certain kinds of tools, since the tool can be kept running at its best cutting speed at all times, whereas when speed con-

tors a compromise between the two plans is ordinarily made, and small tools and those of a character which require but little speed variation are usually grouped together on short lengths of line shafting, while the larger and more important tools are equipped with individual motors. A typical example of this is in the shops of the Erie R. R. at Hornell, N. Y., where out of thirty-one motors used for driving shop machinery, twelve are connected to line shafts, while the remainder are used for driving individual tools.

Electric motors are adapted not only for operating machine tools; they have equal advantages for the operation of cranes, turn tables, transfer tables,

pumps, elevators and almost any device requiring mechanical power. The same source of energy also is available for lights.

The use of electricity in railroad shops therefore solves at once the question of power transmission and permits the various departments to be located for best results, without reference to their distance from the power house. It introduces economies in the power consumed by the elimination of line shaft losses and enables a small part of the machinery to be operated if necessary without waste of power. It allows the use of cranes, which are almost impossible without it, and increases the output of tools on account of the superior speed control which it affords.

**Electrical Measuring Instruments.**

One of the qualities of the electric current which has had not a little to do with the rapid development of the art of employing it, is the ease and accuracy with which it can be measured. In dealing with direct current machinery there are three quantities which it is frequently desired to measure. These are the current in amperes, the pressure in volts and the work done during a given period, in kilowatt hours.

In connection with the definition of the ampere it has already been mentioned that the amount of silver which a current will deposit from a certain arrangement of silver plates and solution is a measure of its strength, but for practical every-day working a more convenient means of measurement is needed.

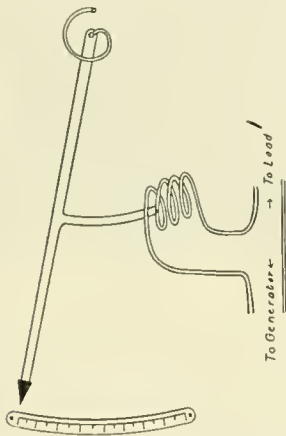

FIG. 1. SIMPLE AMMETER.

The electric current has a number of properties which may be utilized in designing a current measuring instrument, or an *ammeter*, as such an instrument is called. One of these is the production of magnetic action. It has already been noted in previous articles that if a coil of wire be wound around an iron core and a current passed through it, the iron becomes a magnet as long as the current is flowing, and also that the strength of

the magnet depends on the strength of the current. The strength of such a magnet is not proportional to the strength of the current, however, but it depends partly on the size and quality of the iron core, and doubling the strength of the current, for instance, does not necessarily mean that the strength of the magnet will be exactly doubled. If the coil alone is used, however, without the iron core, this by itself will also act as a magnet, although its effect will not be nearly so strong as with the iron core in use. Without the core, however, the magnetic effect will be very nearly proportional to the current and if a small iron core be

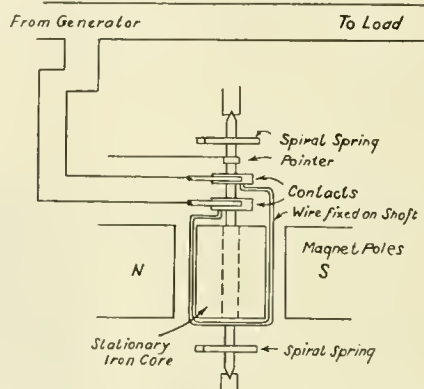

FIG. 2. ELEMENTS OF HIGH GRADE AMMETER.

arranged so as to be drawn into the coil by its magnetic action, against a constant resisting force such as a spring, as indicated in Fig. 1, such an instrument may be used to indicate the strength of the current passing through the coil and may be calibrated to read directly in amperes.

A more accurate instrument may be made by utilizing the action between a magnet and a coil or wire carrying a current, which has been explained in connection with dynamos and motors. If a coil of wire be pivoted between the poles of a permanent magnet so that it can move through part of a revolution, but so that its motion is resisted by a spring, as shown in Fig. 2, then when a current is passed through the wire it will tend to rotate in accordance with the left hand rule and the extent of its motion will be proportional to the strength of the current. By passing different currents of known value through this instrument and noting its movement, it too may be calibrated to indicate the value of the current directly in amperes. This form of instrument may be made to indicate current values very accurately and the majority of all high grade ammeters, although differing in details of construction, are all built on this principle.

In the case of either type of ammeter the same mechanism may be adapted to measure currents of widely different values by simply changing the size of wire and number of turns in the coil, since the the pull of the coil will depend on the

number of ampere turns. Thus for measuring small currents the coil would be made with a number of turns of small wire, while for measuring large currents it would be made with only a few turns of large wire.

If instead of being connected in series with the main circuit as shown in Figs. 1 and 2 either type of instrument were connected directly across the circuit, as shown in Fig. 3, a certain definite current would flow through the coil, independent of the current in the main circuit but depending on the resistance of the coil and on the voltage of the circuit. The reading of the instrument would now be proportional to the voltage of the circuit, and by connecting it to different circuits of known voltage and noting its readings, it could be calibrated directly in volts and thus becomes a *voltmeter*.

It is desirable that a measuring instrument should change the conditions of the circuit to which it is connected, just as little as possible and therefore ammeters are ordinarily made with a very low resistance so as not to unduly increase the resistance of the circuit and thus reduce the currents which they measure to values lower than the values with the instrument removed. For the same reason voltmeters are ordinarily wound with many turns of fine wire so as to have a high resistance and thus take as little current as possible from the circuit whose voltage is to be measured.

Where it is desired to measure large currents it is sometimes inconvenient to carry the entire current through an instrument and in such cases use is made of the principle that "current equals volts divided by resistance." For such measurements a low resistance of known value is placed in the circuit in which it is desired to know the current and a delicate voltmeter calibrated to read down to thousandths of a volt is connected to the

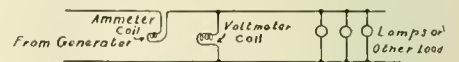

FIG. 3. VOLTMETER AND AMMETER CONNECTIONS.

terminals of the resistance. From the value of the resistance and the reading in volts, the strength of the current can be calculated, or the voltmeter can be calibrated in connection with its particular resistance to read in terms of amperes directly. Such a method has many advantages from the standpoint of convenience over the method of carrying the entire current through the ammeter. The voltmeter used for such a purpose is called on account of its delicacy a *milli-voltmeter*, the term *milli* meaning a thousandth. The known resistance is called a *shunt*. Most ammeters of the permanent magnet type consist of a milli-voltmeter used in connection with a shunt, the lat-



ter being sometimes an integral part of the former and sometimes supplied separately. The connections for this arrangement are shown in Fig. 4.

The type of instrument shown in Fig. 2 has an additional advantage over that shown in Fig. 1 in that it will indicate the direction of the current as well as its strength. The type of instrument shown in Fig. 1 will operate equally well with the current entering either side of the coil. In the instrument shown in Fig. 2, however, the direction of the motion of the pointer of the instrument bears a fixed relation to the direction of the current and when this relation has once been determined, the instrument will readily indicate which is the positive and which the negative side of the circuit. An instrument which has this quality is said to be *polarized*.

If a small motor is constructed using no iron in either the field magnets or the armature core, and if the field magnets be made of a few turns of heavy wire and connected in series with the circuit, like an ammeter, then the strength of the field magnets will be strictly proportional to the current flowing through the circuit. If the armature be made with many turns of fine wire and be connected in series with a large resistance and the circuit thus formed be connected across the supply circuit, as shown in Fig. 5, the current in the armature will be proportional to the voltage of the circuit. In any motor the torque is proportional to the product of the strength of the field by the ampere wires on the armature, that is, by the number of wires on the armature multiplied by the amperes in each. The torque of such a motor, therefore, will at any time be proportional to the product of the current in the circuit by the voltage of the circuit, that is, the torque will be proportioned to the watts or kilowatts in the circuit.

In such a motor as the one just described the torque tends to make the armature rotate. If the armature is connected to a load of any sort, it will speed up until it reaches a point where the torque required to drive the load at that speed just balances the torque produced and it will then run uniformly at that speed as long as the torque produced in it is uniform. If now the armature of the motor is connected to a load of such a sort that the torque required to drive it at any speed is strictly proportional to the speed, so that to drive the motor at fifty revolutions per minute will require twice the torque necessary to drive it at twenty-five revolutions per minute, then the speed at which the motor is running at any time is a measure of the kilowatts in the circuit. Again, if, say, two kilowatts in the circuit will cause the motor to run at fifty revolutions per minute, then if two kilowatts is maintained in the circuit for one hour, so that the total

energy used is two kilowatt hours, then the motor should run at the rate of fifty revolutions per minute for one hour or a total of three thousand revolutions. If the two kilowatts were maintained in the circuit for only half an hour, so that the total energy was only one kilowatt hour, the motor would then run at the rate of fifty revolutions per minute for half an hour and thus make only fifteen hundred



FIG. 4. CONNECTIONS FOR SHUNT TYPE AMMETER.

total revolutions, or half as much as before. With such a device, therefore, the total revolutions run in any given time is proportional to the total energy used during that time. By attaching a suitable revolution counter to the shaft of the motor and properly calibrating it, the motor can be made to measure the total or integrated load used during any given period. Such a device is called an integrating wattmeter, and it measures the total amount of electrical energy used in the same way that a gas meter measures the total quantity of gas.

A suitable device for acting as a load on a motor such as the above, and the one which is commonly used for such a purpose, is a disc of metal mounted on the shaft and having its edge passing between the poles of a permanent magnet. The disc passing between the mag-

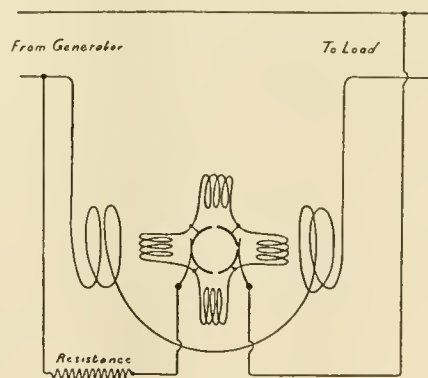

FIG. 5. CONNECTIONS OF INTEGRATING WATTMETER.

net poles has an e.m.f. generated in it which causes a series of currents to flow from one part of the disc to the other. These currents are always in such a direction that the action between them and the lines of force of the magnet is such as to oppose the rotation of the motor. The strength of the magnet being constant, the e.m.f. generated in the disc is hence proportional to the speed. Also the resistance of the disc being always the same, the currents which flow in it are proportional to the e.m.f. The retarding action between magnet and disc is proportional to the current and hence to the speed of the disc.

Erie's Mallet Articulated Compound.

Previous to going out to its career of train moving, what is now the largest and most powerful locomotive in the world, recently built by the American Locomotive Company at their Schenectady works for the Erie Railroad Company, was inspected one day last month by a party of newspaper men and others who went from New York as guests of the builders. It may be that locomotives of greater size and power will yet be built, but it will be for railways having larger height and width for passage of trains than the Erie Railroad.

The locomotive inspected was one of three mallet-articulated compounds, having the enormous weight of 499,000 lbs. in working order. All the weight rests upon the driving wheels, and is therefore available for adhesion, which permits the cylinders to transmit without loss from slipping power sufficient to develop 94,800 lbs. of traction effort.

To the ordinary observer this locomotive looks like two large consolidation engines twined together, and it possesses more than the power of two such locomotives working in unison, but with unison much more complete than what would be possible with two engines having separate throttles and separate operators. When an expert examines the details of these two-in-one locomotives he finds much to admire in the perfection of mechanism employed to produce through duplex parts a harmonious unit of motive power. The feature of flexibility has demanded unusual efforts of ingenuity from the designer, but it has been properly mastered in every detail. Flexible joints of steam pipes to high and low pressure cylinders have been a troublesome detail, but the use of such joints for three years on the Baltimore & Ohio Mallet compound without the least sign of weakness proves that the method adopted of making such joints is successful. The articulated connection between the frames is another detail worked out with entire satisfaction to all concerned. A very simple form of reversing gear designed by Mr. C. J. Mellin, which reverses and regulates the power of both engines, has been introduced, an invention that deserves a place on every modern locomotive.

The principal particulars about the engine are that two sets of running gear, or trucks, each holding four pairs of driving wheels, are secured together by articulated joints that are relatively as strong as the knee joints of an elephant. Each truck carries two cylinders, the high pressure cylinders being both on the hind truck, while the low pressure cylinders, like great wine hogsheads, are prominent in front.

As these engines will work as much backward as forward, it was necessary to locate the dome as near the center of the boiler as possible. The dome, therefore, which is of cast steel, has been placed on the top of the conical course. The throttle, which is clearly

equipped with piston valves, and the low pressure cylinders with Richardson slide valves. The valve gear is of the Walschaerts type. By an ingenious arrangement of the reversing gear the weights of the valve motions of the front and rear engines counterbalance

Exhaust steam from the right high pressure cylinder passes through a cored passage to the back of the cylinder casting, from whence it passes through an outside U-shaped pipe connecting to a passage in the left cylinder casting leading up into the intercepting

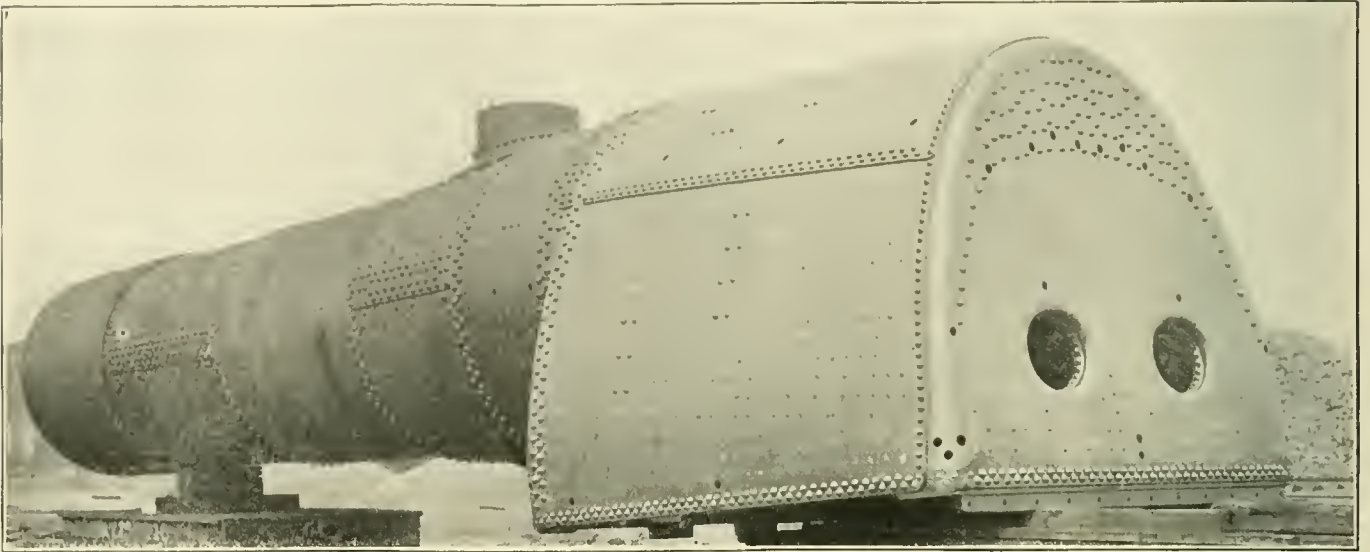

BOILER OF THE MALLET COMPOUND FOR THE ERIE.

shown in our line engraving, acts also as a steam dryer. Steam is admitted through the top only, and the water entrained strikes against the walls of the special shaped casting covering the top of the throttle pipe, and, as is the tendency of water under pressure, follows the surface of this casting and passes down through the center of the valve instead of going into the dry pipe. Steam is led from the throttle pipe through a short dry pipe to a point directly in line with the high pressure

each other. Both eccentric cranks are on leading the pins, the rear engines take the forward motion from the top of the link and the front engines from the bottom of the link. The operation of the engine is rendered easier than that of an ordinary road engine by the application of pneumatic reversing cylinders to the ordinary gear, with positive automatic lock, which holds the lever in any desired position.

The high pressure cylinders are cast in pairs, with saddles, the separation

valve chamber, into which the exhaust steam from the left high pressure cylinder also passes. The emergency exhaust valve is located in the side of the left cylinder casting, and has a 4½ in. jointed pipe connection, with an opening in the back of the exhaust pipe, in the smoke box. A three-way cock within easy reach of the engineer operates the emergency exhaust valve.

The general appearance of the engine can be seen through our engravings. The cylinder dimensions are

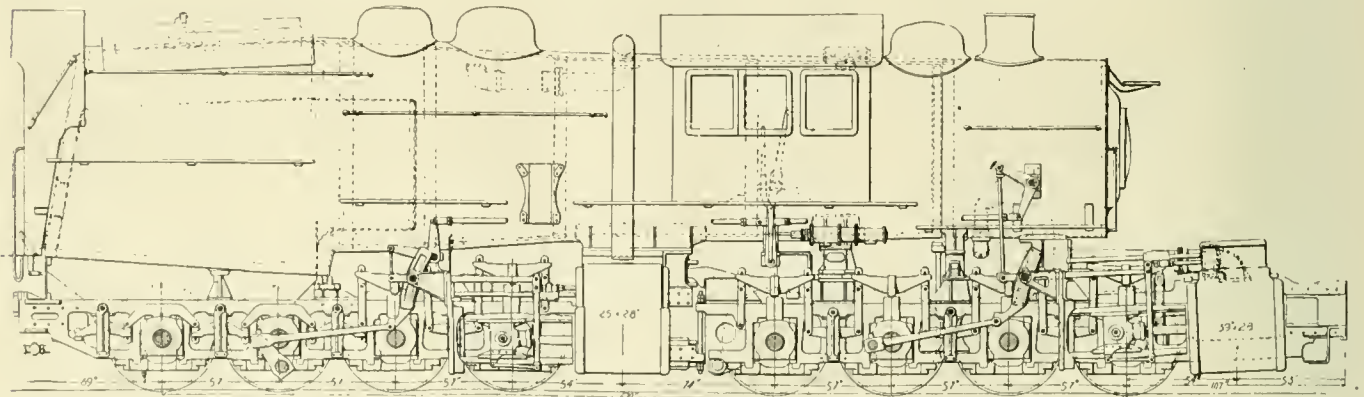

SIDE ELEVATION OF ARTICULATED COMPOUND FOR THE ERIE.

cylinders, from whence it passes through the top of the shell and is divided in a tee-pipe and passes down through wrought iron steam pipes on either side of the boiler to each of the high pressure valve chambers.

The high pressure cylinders are

between the two cylinders being 8½ ins. to the right of the center line of the saddle, to make room for the receiver pipe. The engines are compounded on the Mellin system, the intercepting valve being located in the upper part of the left cylinder casting.

25 and 39 x 28 ins.; tractive effort working simple, 94,800 lbs. The boiler provides 5,313.7 sq. ft. of heating surface, and has 100 sq. ft. of grate area. The boiler pressure is 215 lbs. to the sq. in. The high pressure cylinders have American piston valves, and the low pressure

Richardson balanced valves. The following are the weights of the leading parts:

	Lbs.
Boiler, with tubes.....	96,000
H. P. cylinders, complete with heads .....	18,700
L. P. cylinders, complete with heads .....	19,400
Frames, complete, front engine..	16,300
Frames, complete, back engine..	16,120
Driving wheels, complete with tires .....	47,900
Driving axles.....	10,600
Driving boxes.....	9,600
Rods complete.....	6,600
Pistons and rods.....	3,600
Crank pins.....	2,400
Cab .....	2,500
Smoke stack complete.....	1,100
Sand boxes.....	2,100
Ash pan (estimated).....	2,900
Grate (estimated).....	6,700
Brake works (estimated).....	7,000
Lagging and jacket.....	3,000
Castings .....	26,600
Water .....	42,800
<b>Total .....</b>	<b>341,920</b>

Standing on one of the numerous steam chests, our chief editor broke a bottle of champagne, saying: "I name thee Angus, and may you be a faithful servant to your owners, the Erie Rail-

ins.; ratio of weight on drivers to tractive effort, 4.3; heating surface, vol. equiv. simple cylinders, 217; grate area, vol. equiv. simple cylinders, 408.

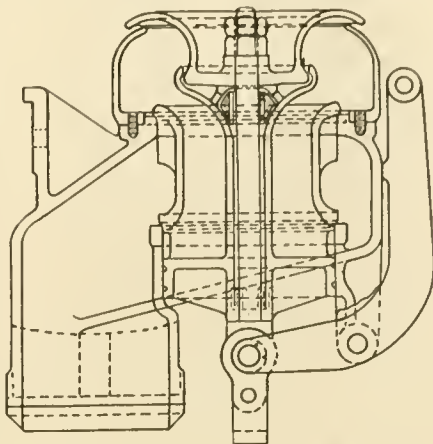

THROTTLE VALVE, ERIE COMPOUND.

road Company." Then the crowd cheered and the ceremony was over.

Some days afterward President Underwood, of the Erie, wrote to Angus Sinclair, saying, "The engine is going

Machine Shop Reminiscences.

III.—SHAW'S CLOSET.

When Shaw was brought into the machine shop we were surprised at the appearance of the new hand. He wore a long tailed coat and a pair of long side whiskers and an air of profound melancholy. He looked as if he had seen better days, and so did his shining garments. His Prince Albert coat glistened like a coat of mail. He was built on colossal lines, and his broad, benevolent feet spread the uppers of his shoes over the soles like steam chest lids. His palms were white and soft as a lady's, and embryotic whiskers flourished on the backs of his big hands. He smiled sadly and asked if he could get a closet to himself. Certainly. The closets were constructed in groups of three together, and Shaw took a trio. He began to disgorge and unrobe. Parcels were drawn from mysterious receptacles in his capacious



CEREMONY OF CHRISTENING THE ANGUS ARTICULATED MALLETT COMPOUND FOR THE ERIE.

T. Rumney, Mechanical Superintendent.

American Locomotive Company, Builders.

When the party of newspaper men had satisfied their curiosity and loaded their note books with particulars about the engine, some one proposed that the largest member of the railroad motive power family should be christened. Angus Sinclair was chosen to do the christening. A variety of names was suggested, but none of them was considered satisfactory till Harry Vought exclaimed: "What's the matter with Angus?" All agreed that Angus was a good locomotive name, and that was bestowed upon the engine.

in our official records as the Angus Type Articulated Compounds. This is but a faint recognition of the obligations the railroad companies are under to you for things too numerous to mention."

Some of the principal dimensions are as follows:

Wheel arrangement, .o88o; total weight, 309,000 lbs.; size of cylinders, 25 and 39 x 28 ins.; diameter of drivers, 51 ins.; tractive effort (working simple), 94,800; total wheel base, 39 ft. 2 ins.; driving wheel base, rigid, 14 ft. 3

coat, and glimpses could be had of claw hammers and alligators and pincers and decrepit pipe tongs and sad looking soldering bolts. The collection looked like the window of a Second avenue pawn shop after a fire. The instruments, such as they were, all showed signs of having, like Othello, done the State some service; but it must have been away back in the sixties. By the time he got his well-worn tools into the closet and himself into a new suit of overalls, every eye in the shop was upon him. He hid his collection of curiosities in the closet,

and we mercifully hid him in the pit. There was a new set of shaking grates to fit up, and Shaw started drilling holes in the fire-box. He worked busily and came out of his hole occasionally to quench his thirst at the water barrel, as new hands always do on their first day in a new shop. At twelve o'clock when Billy's cat came along the floor and the whistle blew and the wild stampede was made for Clark's parlors, Shaw soberly took a package out of his closet and sat down on a plank in the pit, and, crossing his legs like a Turkish Bashaw, he uncovered a half loaf of bread and a half of a smoked haddock, and Billy's cat immediately fell in love with Shaw and his haddock.

Shaw and Billy's cat were still busy dissecting the veterbrae of the haddock when Jack Macfarlane, an upstairs vise

parlors at six o'clock, and also to meet himself alone occasionally at the same place. Shaw agreed at once, and the worthies shook hands. Shaw duly "wet his job," and plodded along in a heroic effort to catch up with his half-forgotten trade. He was great at losing tools, and clever at clutching at the tools of others. If he lost his lamp, others lost their lamps shortly afterwards. An air of mystery soon gathered around Shaw's closet. Missing articles or their ghosts were said to have been seen there. The climax came one day at noon when a piston had suddenly to be taken out of a refractory engine. A short piece of round steel with a little projection on the centre of one end was missing. It was adapted for setting between the end of the piston rod and the main rod front end, then with a taper key and a blow

tended doing with that wrench I brought with me from the C., B. & Q.?"

"And there's the pair of pliers that I took with me when I left the D., L. & W.! I'll pinch him!"

"See them compasses—that's a pair I took from the old country. See the initials where I changed them to J. W.? Joe Watt, used to be I. K. I'll put a mark on that haddock man!"

"Catch sight of my squirt can? N. G. on the bottom. Used to belong to Nick Gordon, of the B. & M. I forgot to give it to him when I left Boston. I'll hurt that fish dealer! What would Nick think if he knew I was taking such poor care of his can?"

"Blowed if there ain't that plumb bob that I found in the shop when I finished my time on the Erie! I'll level up that fish man."

"Look at that chisel, where I filed out the marks of the Central and put my own mark on—three stars! I'll mark that cadger. I'll make him see stars—sure's your born."

In the midst of the confusion Shaw and Jack returned leisurely from Clark's parlors. When Shaw saw the ruin of his closet his jaw fell. Jack pleaded eloquently that the articles were merely temporary loans. They were common property, he claimed, the flotsam and jetsam of railroad machine shops; but when Jack's eyes fell upon a hammer that had once belonged to a Paterson machinist, and which, in a moment of need, Jack had appropriated to himself, it was too much. He turned on Shaw, who burst into a flood of tears, and declared that it had never entered into his mind that these worn-out tools came under the heading of personal property. Macfarlane suggested a heavy fine to be paid in liquid compounds at Clark's parlors, and the sweet peace that comes to brethren who have been tried in the furnace fires of experience, and who by self-revelation have become transparent to each other, fell upon them, and they felt that there was not one in the motley throng who, by wearing the white flower of a blameless life, could be justified in casting the first stone at Shaw, the ex-haddock smoker. The night at Clark's parlors was one that was long remembered.

#### The M. C. & L. P. A. Association.

The thirty-eighth annual Convention of the Master Car & Locomotive Painters' Association will be held in St. Paul, Minn., September the 10th to 13th. The Hotel Ryan has been selected as headquarters. A number of interesting papers have been prepared. Mr. A. P. Dane of the Boston & Maine Railroad at Boston, Mass., is the secretary of this Association. Any communications concerning the Convention may be addressed to him.

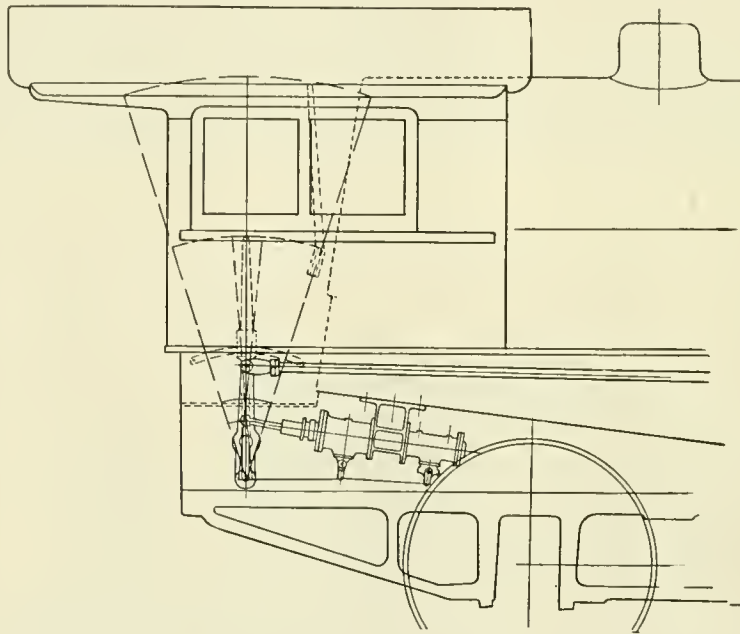

REVERSING GEAR ON THE ERIE MALLET COMPOUND.

hand, came hastily back from Clark's parlors and jumped into the pit. Shaw turned red, white and blue. Jack asked Shaw how the fish business was, and what he meant by coming into a machine shop. Shaw's voice came floating out of the fire-box door into the cab and we could hear him pleading, with all the tremulous fervency of the passionate exhaust of an overworked freight engine, for Jack to let bygones be bygones and not to speak to any one of his past career. Jack was awed into silence while Shaw proceeded with his argument. It appeared that Shaw had worked as a machinist many years ago, but had become a dealer in smoked haddocks; but had given them up in despair, and he did not wish it to be known now that he had a chance to begin again at his old trade.

Jack stipulated that it would be necessary to meet a select coterie at Clark's

struck with a sledge hammer the piston and crosshead would part from each other. Some genius suggested Shaw's closet. It would have been better for Shaw if he had remained near his closet and ate his dry bread and haddock at high noon alone rather than to have gone to Clark's parlors, but he was under contract to Jack Macfarlane, and Jack worked Shaw for all he was worth. Shaw's closet refused to be opened. Keys were useless, but a crowbar wrenched the hinges from it.

The sight that met the eyes of the mystified mechanics was wonderful. Everything from a steel scriber to a rusty screw-jack was there revealed in one tangled mass. The scattered forces were just coming in from Clark's parlors and Shaw's closet suddenly became the center of a storm. The comments were hot. Among the coolest were the following:

"I wonder what that fish cadger in-

# Items of Personal Interest

Mr. Chas. Reitch has been appointed traveling engineer of the International & Great Northern.

Mr. Leonard Ruhle has been appointed master mechanic of the Colorado & Northwestern, with office at Boulder, Col.

Mr. B. F. Elliott has been appointed assistant master car builder of the Mexican Central, with office at Aguascalientes, Mex.

Mr. G. D. Fowle, formerly signal engineer of the Pennsylvania, has been appointed consulting engineer on the same road.

Mr. C. B. Gray has been appointed assistant master mechanic of the Pennsylvania Railroad, with headquarters at Ormsby, Pa.

Mr. Thos. Hickson has been appointed master mechanic of the Illinois, Iowa & Minnesota Railway, with headquarters at Rockford, Ill.

Mr. W. K. Christie has been appointed master mechanic of the Kalamazoo, Lake Shore & Chicago, with office at South Haven, Mich.

Mr. W. J. Bergen has been appointed assistant to the chief engineer on the New York, Chicago & St. Louis, with office at St. Louis, Mo.

Mr. C. E. Roach has been appointed roundhouse foreman of the Rock Island Lines at Horton, Kan., vice Mr. O. V. Harrison, resigned.

Mr. M. M. Meyers has been appointed master mechanic on the Missouri Pacific, with headquarters at De Soto, Mo., vice Mr. A. S. Grant, resigned.

Mr. A. C. Brower has been appointed division engineer of the Missouri Pacific, with headquarters at Wichita, Kan., vice Mr. E. C. Welch, transferred.

Mr. E. R. Morgan, formerly foreman of the Texas & Pacific, has been appointed foreman on the Southern Pacific Railway, with headquarters at San Antonio.

Mr. A. H. Rudd, heretofore assistant signal engineer, has been appointed signal engineer on the Pennsylvania Railway, vice Mr. G. D. Fowle, promoted.

Mr. F. E. Fox, master mechanic on the Rock Island at Goodland, Kan., has been appointed to a like position on the Denver & Rio Grande at Burnham.

Prof. Chas. H. Benjamin has been appointed dean of the school of engineering at Purdue University at Lafayette, Ind., vice Prof. W. F. M. Goss, resigned.

Mr. S. P. Spangler has been appointed master mechanic of the St. Louis, Watkins & Gulf, with office at Lake Charles, La., vice Mr. J. C. Ramsey, resigned.

Mr. G. A. Baker has been appointed superintendent of motive power of the Santa Fe Central, with office at Estania, N. Mex., vice Mr. T. J. Tonge, resigned.

Mr. H. W. Ridgway, master mechanic of the Colorado & Southern at Trinidad, Col., has been transferred to Denver, Col., vice Mr. D. Patterson, resigned.

Mr. W. O. Thompson, secretary of The Traveling Engineers' Association has had his address changed, to care of the New York Central Shops at East Buffalo, N. Y.

Mr. T. J. Tonge has resigned as superintendent of motive power of the Santa Fe Central to become connected with the El Paso & Southwestern, at Santa Rosa, N. M.

Mr. James Kelliher, formerly general foreman of the Union Pacific shops at North Platte, has been promoted to be district foreman at Council Bluffs on the same road.

Mr. W. H. Sleep, formerly foreman blacksmith Grand Trunk Railway, has been appointed master blacksmith Canadian Pacific Railway at the Angus shops at Montreal.

Mr. William H. Bradley has been appointed assistant master mechanic for the Iowa division of the Chicago & Northwestern Railway, with headquarters at Boone, Iowa.

Mr. F. W. Dickinson has been appointed master car builder of the Bessemer & Lake Erie Railroad, with headquarters at Greenville, Pa., vice Mr. W. J. Buchanan, resigned.

Mr. Iva W. Enos has been appointed road foreman of engines on the Pere Marquette Railroad, vice Mr. H. D. Kinsella, resigned. His offices are at Grand Rapids, Mich.

Mr. E. Conniff, general foreman on the Baltimore & Ohio Railroad, has been appointed master mechanic on the same road with headquarters at Benwood, W. Va., vice Mr. F. C. Scott, resigned.

Mr. E. D. Andrews has been appointed master mechanic on the Chicago, Burlington & Quincy on lines west of the Missouri River, with office at Sterling, Col., vice F. Newton, resigned.

Mr. F. E. Doxey, formerly foreman of shops of the Illinois Central at Waterloo, Ia., has been appointed master mechanic of the Des Moines, Iowa Falls & Northwestern, with headquarters at Iowa Falls, Ia., vice Mr. L. C. Rost, resigned.

Mr. Charles Coleman, formerly shop foreman of the Chicago & Northwestern Railway at Winona, Minn., has been appointed division foreman for the same company at Boone, Iowa, on the Iowa division, vice C. D. Higgins, resigned.

Mr. M. J. LaCourt, heretofore foreman of the car department of the Chicago, Milwaukee & St. Paul at La Crosse, Wis., has been appointed general travelling inspector of cars on the same road.

Mr. M. A. Kinney, formerly roundhouse foreman of the Baltimore & Ohio at Newark, Ohio, has been appointed master mechanic of the entire Hocking Valley system, with headquarters at Columbus, Ohio, vice Mr. E. J. Powell, resigned.

Mr. F. D. Laughlin, formerly vice-president of the Atlantic Brass Co., has been appointed eastern sales manager of the Pittsburg Pneumatic Company of Canton, Ohio, vice Mr. G. B. Harris, resigned. His headquarters are at 90 West Street, New York.

Mr. R. P. C. Sanderson, for several years superintendent of motive power of the Seaboard Air Line Railway, has resigned that position to accept the appointment of superintendent of motive power of the Virginian Railway, with headquarters at Norfolk, Va.

Mr. J. Dietrich, assistant superintendent of motive power on lines west of the Missouri River on the Chicago, Burlington & Quincy, has been appointed master mechanic of the Lincoln division on the same road, vice Mr. J. J. Butler, assigned to other duties.

Mr. Winfield L. Larry, master mechanic of the New Haven's Taunton division, has resigned to become an extra inspector, on the staff of the railroad commission of Massachusetts, and will devote his attention to conditions and practices in the locomotive departments of the railroads of that State.

Mr. H. S. Hoskinson, who has been for some time connected with the Dressel Railway Lamp Works of New York, has recently been elected to the position of secretary of that company. Mr. Hoskinson was for many years general storekeeper of the Central Railroad of New Jersey.

Mr. John Reid, who for several years has been connected with the Consolidated Railway Electric Lighting & Equipment Company, has resigned from that company to accept the position of assistant to the vice-president in charge of sales of the Bliss Electric Car Lighting Company, with headquarters at their New York office, Night and Day Bank Building.

Mr. Frank Richards has become managing editor of *Compressed Air*. He is well known as the author of the book "Compressed Air." He was for ten years one of the editors of the *American Machinist*. Previous to his work on that

publication Mr. Richards spent years in the machine manufacturing business, part of the time as superintendent of shops of the Ingersoll-Sergeant Drill Company.

The Interstate Commerce Commission have recently appointed what is known as the Block Signal and Train Control Board. The members of this board are, Mr. M. E. Cooly, chairman, dean of the department of engineering in the University of Michigan; Mr. A. Anes, Jr., signal engineer of the Electric Zone on the New York Central; Mr. F. G. Ewald, consulting engineer of the Railroad and Warehouse Commission of Illinois; and Mr. B. B. Adams, associate editor of the *Railroad Gazette*. The secretary is Mr. W. P. Borland and the office of the board is at the headquarters of the Interstate Commerce Commission at Washington, D. C. The duty of these gentlemen will be to investigate and report on the use of, and the necessity for, block signal systems and appliances for the automatic control of railway trains in the United States.

Mr. John F. Long has been appointed general foreman of the St. Louis & San Francisco Railroad at Chaffee, Mo. Mr. Long entered the service of the Kansas City, Pittsburg & Gulf, now the Kansas City Southern, at Pittsburg, Kan., where he was stationed for five years. In 1900 he entered the service of the 'Frisco system at Monett, Mo., in charge of special appliance work on engines, and in 1905 was advanced to the position of assistant general foreman at the same point. Next year he was promoted to division foreman at Beaumont, Kan., and has recently been made general foreman of the 'Frisco system at Chaffee. Mr. Long is a valued contributor to RAILWAY AND LOCOMOTIVE ENGINEERING and his steady advancements in railroad service is a matter of satisfaction to his wide circle of friends.

Mr. Harris Tabor, inventor of the Tabor indicator and of the Tabor molding machine, one of the best known mechanical engineers in the country, met with a most serious accident a few weeks ago which almost put a premature end to a very useful career. Like many other engineers, Mr. Tabor had been infected with the automobile contagion. The accident he went through proves that the most careful and efficient drivers may meet disaster on an automobile, for Mr. Tabor was noted among his friends as a cautious driver. In trying to turn his machine on a road that was on a precipitous ridge, he missed his calculation and went over a precipice fifty feet deep. The machine struck trees in its descent which probably saved the occupants from death. As it was Mr. Tabor had four ribs broken, one of which pierced a lung, and Mrs. Tabor had an arm broken. In spite of the terrible injuries he received Mr. Tabor has recovered. He passed through the battle of Gettysburg without a scratch, and it would have been a grim

turn of fate had he perished in an automobile accident.

Mr. William B. Rudd, of Media, and Geo. J. Richers, of Altoona, are the successful candidates for the Frank Thomson scholarships this year. Two scholarships will hereafter be awarded every year to Pennsylvania Railroad employees. Mr. Rudd is a son of A. H. Rudd, signal engineer of the Pennsylvania system. He is seventeen years of age and is a graduate of Media High School. He will enter the Sheffield Scientific School of Yale University in the fall. Mr. Geo. J. Richers is a son of Henry O. Richers, who is employed in the cabinet shops of the Pennsylvania at Altoona. He is 24 years of age and a graduate of Altoona High School. He was employed as a messenger in the office of the general superintendent of motive power in Altoona in August, 1900, and was later transferred to the machine shops as an apprentice. While working in the shops he pursued his studies at night, and after completing his course in the shops in 1905 graduated from the Altoona High School in 1906, when he entered the University of Pennsylvania. He has just completed one year there. The Frank Thomson scholarships were established by Ann Thomson, Frank G. Thomson and Clark Thomson, children of the late Frank Thomson, formerly President of the Pennsylvania Railroad Company. The grantors of this trust fund of \$120,000 declared that it was their desire to afford to the sons of living and deceased employees of the lines of the Pennsylvania Railroad, an opportunity for a technical education. The scholarships amount to \$600 a year.

#### Fitting a Smoke Stack.

The proper fitting of a smoke stack is no job for a first year's apprentice. He must be a master mechanic with the hammer and chisel who fits a smoke stack as it should be fitted. Years ago it was a case of fitting the smoke-stack base, now the locomotives have grown so great that the stack is dwarfed into insignificance and it is, generally speaking, cast in its entirety.

In beginning the operation the engine should be perfectly levelled, the exhaust pipe should be securely bolted to its place and when the stack is set in place, the centre should be carefully found and a line with weight attachment dropped some distance below the opening of the exhaust nozzle. Too much pains cannot be taken to set the stack not only exactly central with the exhaust pipe but also perfectly plumb. As the stack is generally more or less tapering in structure this is not so easily accomplished as it might appear. A good practice is to make marks with chalk at some fixed distance from the inner top or bottom of the stack and carefully callipering from these marks adjust the stack so that the line suspended

from the upper centre will be equidistant from every part of the stack and also pass through the exact centre of the exhaust nozzle.

In securing the stack in position small wooden wedges are best, as chisels or other metallic wedges slip readily out of place when set between the smoke stack and smoke arch. When set and wedged in place the line should be carefully re-examined and if absolutely correct the outer lower part of the smoke-stack base should be chalked and with a pair of callipers furnished with one straight and one curved point the required marking can be made, the amount depending on the largest open space between the casting and smoke arch. In marking, the callipers should be held perfectly level as well as perfectly plumb, and it is well after the marking has been made, to test the line at several points to ascertain if the marking has been correctly made.

Sharp centre punch marking along the line is the simplest and surest method of retaining the marking as the chalk soon falls away when the operation of chipping begins. It is customary in chipping a smoke stack as in chipping a saddle to chip the inner fitting strip to a lower depth than the outer strip. The variation from the outer strip should be very small, a thickness of paper being enough, as the arched formation of the smoke box is of great rigidity and renders it inflexible to any variation in bearing surfaces. A straight edge must be carefully used in testing the chipped surface and a thin coating of lamp black on the smoke arch will aid in completing the perfect fit. The time spent in readjusting the line after the first trial is time well spent, and in the event of the chipping having passed through the fitting strips it is well that the central space between the fitting strips should be deepened as the perfect fitting of wide bearings on arched surfaces is extremely difficult under any condition. The perfect fit of the smoke stack should never be treated as a light matter. Cement and putty cover a multitude of blemishes in stone or wood work, but iron and steel exposed to the expanding action of fire can never depend on plastic substances to correct any misfitting of parts, and a leak in the base of the smoke stack is a leak of the most pernicious kind.

It should be noted when the smoke stack is set in place that the opening in the smoke arch does not project or overlap the casting in any part. Such overlapping portions should be carefully removed. Their effect on the fire must be seen to be believed. The relation of the exhaust pipe to the smoke stack is a subject that will require another article, but it is safe to assume that one of the most vital points in connection with the front ends of locomotive engines is the perfect fitting of the smoke stack.

**Geared Locomotive for the C. & O.**

Not long ago the Chesapeake & Ohio Railroad bought some geared, or, as they are occasionally called, Shay, locomotives for use on the heavy grades on some parts of that road. These engines have a rigid wheel base of only 64 ins., and the entire weight of both engine and tender rests on the drivers. On account of the very short rigid wheel base very sharp curves can be

run through without difficulty, and a greater variation in the surface of the track can be passed over by these engines than would be possible with ordinary locomotives.

The builders of these Shay, or geared engines, are the Lima Locomotive and Machine Company, of Lima, Ohio, and our illustration gives a good idea of the product of their shops. Six of these engines have recently been built for the C. & O., two have been ordered by the Southern Railway, and one by the Norfolk & Western. The cylinders, three in number, are simple 17 x 18, and the driving wheels, of which there are eight pair, are 46 ins. in diameter. The tractive power of this engine is 53,000 lbs., and as the entire weight of the engine and tender, which is 300,000 lbs., is on the drivers, the factor of adhesion is 5.66. The method of calculating the tractive effort of a geared engine was given in RAILWAY AND LOCOMOTIVE ENGINEERING for March, 1906, on page 128, and the formula is somewhat different to that used for ordinary steam railway engines, though the principle involved is the same in each case. The driving wheels of this locomotive receive twelve piston impulses per revolution, making the draw-bar pull uniform and thus reducing the tendency to slip. The greater number of exhausts makes a more steady draft on the fire than is the case with the regular type of locomotive, and this permits the use of a large nozzle, and, consequently, reduces the tendency to draw unburnt coal drawn through the flues, and altogether the geared engine makes a very good showing on economy for evapora-

tion. The valves used are the Allen-Richardson type, with a travel of  $4\frac{3}{8}$  ins. They have 15-32 in. outside lap. The steam ports are  $1\frac{1}{2}$  x  $15\frac{1}{2}$  ins; the exhaust is  $2\frac{1}{2}$  ins. by same length and the bridges are  $1\frac{1}{8}$  ins. wide.

The boiler is made in the extension wagon top style, with a diameter at the smoke box end of  $63\frac{3}{4}$  ins. The steam pressure carried is 200 lbs. to the sq. in. The fuel used is soft coal,

$\frac{3}{8}$  in.; back,  $\frac{1}{8}$  in.; crown,  $\frac{3}{8}$  in.; tube, 9-16 in.; water space, front,  $4\frac{1}{2}$  ins.; back, 4 ins.; sides, 4 ins.

Tender—Wheels, material, cast iron; diameter, 46 ins.; journals, 7x8 ins.

Brake—Westinghouse automatic, Schedule ET.

Ratios—Tractive power per pound M. E. P., 347; total calculated tractive power, 53,000 lbs.; ratio of gearing, 2 to 1; volume of cylinders, 7.16; total heating surface to tube II. S., 1.08; total to firebox II. S., 14.05; tube to firebox II. S., 13.05; grate area, 45.75; heating surface to volume of cylinders, 333; grate area to volume of cylinders, 6.77.

Equipment—Brake beams Lima. Loco. Pat., steel; headlight, C. & O. standard; in-



MODERN SHAY GEARED LOCOMOTIVE FOR THE C. & O.

J. F. Walsh, Supt. of Motive Power.

Lima Locomotive and Machine Co., Builders.

jectors, Hancock inspirators; checks, swing; journal bearings, bronze; pilot couplers, Tower; air sanders, Lima; lubricator, Nathan; tender coupler, Tower; staybolts, flexible, Tate; lagging, Franklin magnesia.

The boiler is made in the extension wagon top style, with a diameter at the smoke box end of  $63\frac{3}{4}$  ins. The steam pressure carried is 200 lbs. to the sq. in. The fuel used is soft coal, and the crown staying is radial. The heating surface is 2,390 sq. ft. in all, made up of 170 in the firebox, and 2,220 in the tubes, of which there are 316, each 13 ft. 6 ins. long. These tubes are made of steel, No. 11, B. W. G., and 2 ins. outside diameter. The grate area is 48.5 sq. ft., and the ratio of grate to total heating surface is about as 1 is to 49. The tender resembles that of an ordinary engine, and has a fuel capacity of 9 tons of coal and 8,000 gallons of water. The tender wheels, like those of the locomotive, are made of cast iron, 46 ins. in diameter, and are also driven by flexible shaft and gears. The wheel base of the locomotive itself is 34 ft. 4 ins.; with that of the tender included the wheel base measures 58 ft. The rigid wheel base in no case exceeds the spread of one truck, which is 64 ins. Some of the principal dimensions and ratios are appended for reference:

Boiler—Material, steel; thickness of sheets,  $\frac{5}{8}$  and 13-16 in.; horizontal seams, butt joint, sextuple riveted with welt plates inside and outside; circumferential seams, double riveted.

Driving Wheels—Material, cast iron; diameter outside, 46 ins.; diameter of center, 40 ins.; journals, 7x8 ins.

Firebox—Material, steel; length, 114 ins.; width,  $61\frac{1}{4}$  ins.; depth, front,  $82\frac{3}{4}$  ins.; back,  $78\frac{3}{4}$  ins.; thickness of sheets, sides,

**Force Feed Lubrication.**

The McCord Force Feed Lubricator is a comparatively new device in the locomotive field, though the principle has been successfully used in stationary and in automobile practice for a number of years.

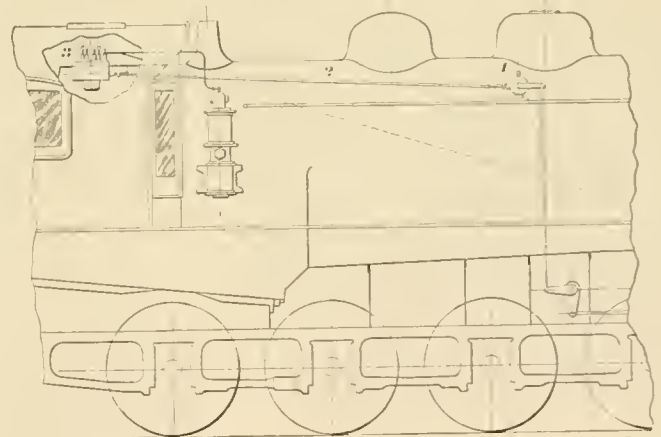

FIG. 1. THE GENERAL ARRANGEMENT.

(1, The transformer; 2, the rotating shaft; 3, the force feed lubricator.)

In the various types of this device made by McCord & Company of Chicago the principle of forcing oil from one reservoir to various bearings, etc., by means of pumps is used. A single pump may be used to force the oil direct from the reservoir to the point of delivery, in case only a bleeder test for seeing the amount fed is desired, but where a constant drip sight feed is desired, two pumps are used. One of these pumps de-

livers the oil from the reservoir to the sight feed, while the other delivers oil from the sight feed to the bearing. The latter type is employed for locomotive practice. There is a pair of pumps for every wearing surface which receives oil and the adjustment can be made so that cylinders using superheated steam can be fully

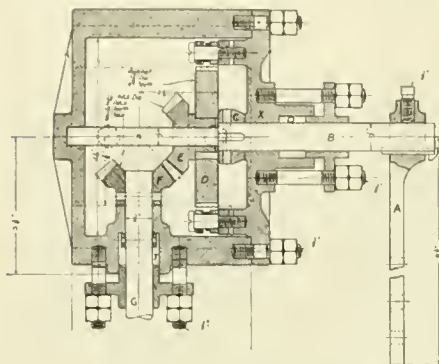

FIG. 2. SECTION OF TRANSFORMER.

oiled or a driving box can be lubricated sufficiently to keep it cool.

The Locomotive Lubricator consists of three parts, viz.: A transformer which takes a reciprocating motion from the rocker-arm or valve-stem, and changes it into a rotary motion. A shaft with two universal couplings which transmits the rotary motion to some point in the cab; and a lubricator which distributes the oil to the various parts to be lubricated.

The general view of the equipment is shown in Fig. 1. Referring to Figs. 2 and 3, the lever A is keyed to the shaft B, to which is also keyed the pawl-lever C carrying the pawls O and P. The ratchet D is keyed to the miter gear E, which runs loosely on the shaft B, while the miter gear F is keyed to the shaft G and

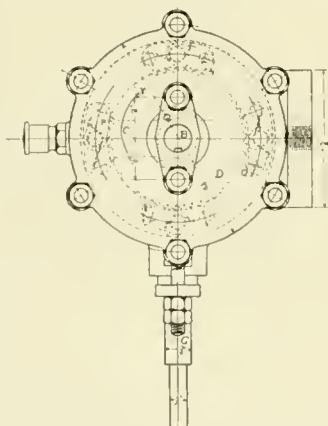

FIG. 3. PLAN OF TRANSFORMER.

meshes with E. The pawls M and N are pivoted on the cover plate X.

When the lever A receives a reciprocating motion from the rocker-arm or valve-stem, the same motion is transmitted through the shaft B to the pawl-lever C. As the pawl-lever C is rotated in the direction of the arrow Y, the pawls

O and P engage the ratchet wheel D, and a rotary motion is thus given the shaft Q, through the miter gears E and F. On the return stroke or swing of the lever A, the pawls M and N engage the ratchet wheel D and prevent it from rotating in a direction opposite to the arrow Y. Thus the shaft G is given an intermittent rotary motion in one direction like the hands of a clock. The whole case is filled with grease, to reduce wear, while leakage is prevented by the stuffing boxes Q and T. The rotary motion given to the shaft B is transmitted through a shaft and universal couplings to the lubricator proper, which is placed on a bracket in the cab.

Referring to Fig. 4, suppose that the reservoir has been filled with oil through the screen W and that the machine has

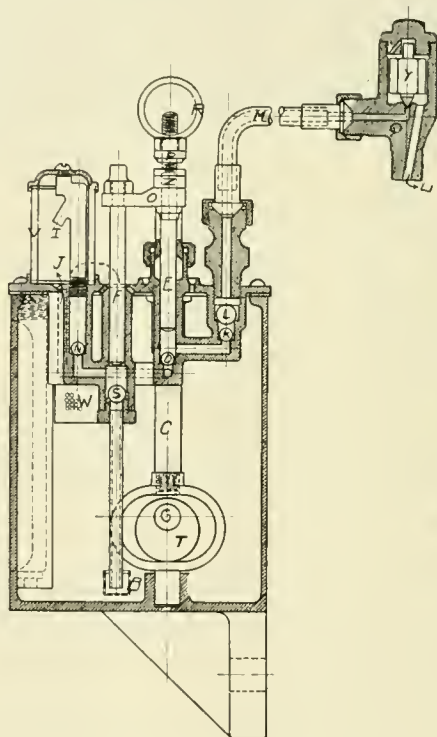
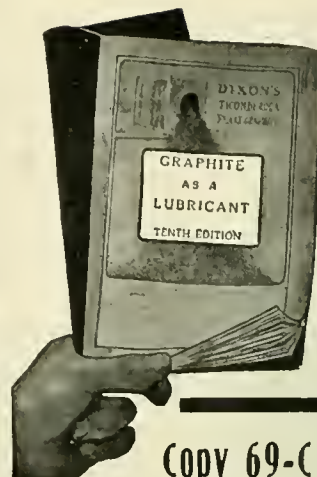

FIG. 4. SECTION OF LUBRICATOR.

been in operation until the entire system is filled with oil. The eccentric T is an integral part of the shaft G, while the crosshead Z is fastened rigidly to the eccentric rod C, but may be adjusted on the pump-plunger E. The crosshead O is fastened rigidly to both pump-plungers E and F, so that whatever motion one has, both have. As the shaft G and the eccentric T are revolved, the eccentric rod C is moved up and down, and imparts a similar movement to the pump-plungers E and F.

When the plunger F moves upward, oil is drawn from the reservoir through the screen B and is lifted above the ball check S, while on the downward stroke the oil is forced past the ball check M, to the point I, from where it drips through the sight feed V. As the plunger



Copy 69-C FREE

Here is a complete and interesting story of graphite and its development as a lubricant. You can not get in any other book of equal size so much information of REAL value. The experience of practical men and the experiments of scientific authorities are both given in this TENTH EDITION of

## "Graphite as a Lubricant"

making it valuable to men of practice and students of theory.

Lubrication in almost every kind of machinery is treated of. "Kinks" and "short-cut" methods discovered and used by resourceful engineers are included.

You should get this book now. Write for FREE copy 69-C.

**JOSEPH DIXON  
CRUCIBLE CO.  
Jersey City, N. J.**



# GOLD Car Heating and Lighting Co.

Manufacturers of

ELECTRIC,  
STEAM AND  
HOT WATER  
APPARATUS  
FOR RAILWAY CARS

EDISON  
STORAGE  
BATTERY  
FOR RAILWAY CAR  
LIGHTING

Largest Manufacturers in the World  
of Car Heating Apparatus

Catalogues and Circulars  
cheerfully furnished

Main Office, Whitehall Building  
17 BATTERY PLACE  
NEW YORK

E moves upward, oil is drawn from the dotted passage J into the pump-barrel above the ball check D, while on the downward stroke, oil is forced past the ball checks K and L through pipe M, and lifts the gravity valve Y in the terminal check Q. The same pressure which forces the oil into the terminal check Q forces it through the passage U, to the bearing. The amount of oil delivered by any pump is governed entirely by the length of stroke given to that plunger and this, in turn is governed by the adjustment of the nurlled nut P which allows a greater

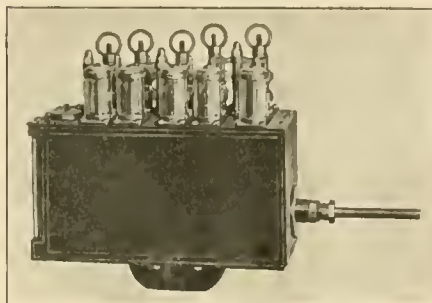

MCCORD LOCOMOTIVE LUBRICATOR.

or less free movement of the crosshead Z on the plunger E.

An interesting feature of this method of adjustment lies in the fact that the ring nut R can at any time be taken hold of by hand and the pump plungers moved so as to deliver any desired amount of oil to a bearing in addition to the adjusted feed, which need not be disturbed during the operation.

This force feed device has been tested on a number of prominent railroads, the principle having been successfully applied in stationary engine and automobile practice, and the following advantages are claimed for it by the makers. The feed is positive, and when properly adjusted, is accurate and adequate. The operation is entirely mechanical. There is a total absence of pressure in the sight-feed chambers and reservoir, thereby preventing leakage and removing the danger of accident to enginemen by the breaking of sight feed glasses. The reservoir can be filled while the lubricator is in full operation. By use of a terminal check valve, the tallow pipes are kept full of oil, thereby insuring delivery of oil with each stroke of the pump. The feed can be adjusted in proportion to the frictional areas. When the engine stops, lubrication stops, and when the engine starts, lubrication commences immediately. By constantly supplying oil in proportion to the frictional surfaces to be lubricated, economy of oil is secured. As previously explained, additional oil may be delivered to any bearing by operating the pump by hand. In applying the device to a locomotive, the lubricator is placed in the cab within easy reach of the engineer, while the transformer may

be placed on the frame, running board, boiler, or in any other convenient position. The universal joints on the shaft, between the lubricator and the transformer, permit operation at an angle of less than 150 degs.

### Mallet Compounds on the N. P.

The Northern Pacific Railroad people have sixteen small Mallet Articulated Compounds in use in train service and most of the people concerned in train operating say that the engines are a decided success. The peculiar cylinder arrangement prevents the engines from slipping, which prevents the breaking in two of trains, it being well known that more drawheads are pulled out by the shocks due to engine slipping than to any other cause. The Mallet Compounds are doing the work of train hauling on from 12 to 17 pounds of coal per one hundred ton mile.

### Brick Arch Revived.

The American Locomotive Equipment Company of Chicago, which have placed upon the market an excellent brick arch for locomotives, are pushing the device with active vigor and several of the leading railroad companies have decided to adopt this efficient smoke preventing and fuel saving aid to combustion. The brick arch has been in use for many years, having been invented by George S. Griggs in 1857 and since that time used all over the world. The arch brought out by the American Locomotive Equipment Company embraces several important improvements which in-

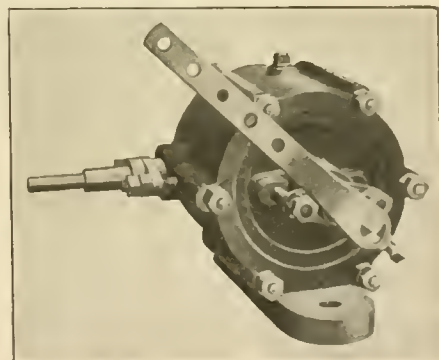

THE TRANSFORMER.

crease its efficiency. No invention introduced upon the locomotive has ever been equal to the brick arch as a fuel saver and the prevailing neglect of the arch has been due to want of interest in ventilating its merits. The American Locomotive Equipment Company are taking the sensible stand of making sure that their arch is properly applied and that it is cared for intelligently. They do not propose permitting this good thing to fall into disrepute through the want of attention which has ruined the prospects of many good inventions.

### Tank Hose Coupling.

The American Coupling Company, of St. Louis, Mo., have what may be called a gravity tank hose coupling, in which simplicity is a prominent feature. The couplings themselves are made of malleable iron, with a coat of nickel to prevent rust, and they go together easily and quickly.

Our illustration gives a general idea of the device, the flange of one coupling is tapered to conform with the lugs of the other. To make the joint, the coupling with the lugs which is attached to the tank hose is lifted and slipped over the other, and the operation is complete.

The coupling is kept tight by means of a gasket made of high grade medium hard rubber, moulded in ring form so that in case of wear the renewal of a gasket is only the work of a few moments. The natural sag of the hose and the weight of the couplings tends to keep the joint tight and any shaking which may be caused by the motion of the engine and tender works to the same end. The rubber gasket is in the flange face of the coupling which is applied to the engine hose and it is tightly squeezed against the plane face of the coupling having



GRAVITY TANK HOSE COUPLING.

the lugs. This gasket is made in the form of a solid ring like the rubber band that is sometimes used on umbrellas to keep the ends of the ribs close to the stick when the umbrella is not in use. It is really a cylinder bent in the form of a circle. The gasket used in this case is embedded in the coupling just a little deeper than its center so that it cannot work out.

The illustration shows two set screws, but these are not used in the later type of coupling made by this company. Service tests made for over 18 months have demonstrated that for locomotive use the joint when once made remains tight.

### The Diligent Man.

"Seest thou a man diligent in his business. He shall stand before kings, he shall not stand before mean men." When Solomon uttered these wise words he paid a high compliment to

industry, which is a primal virtue. He knew that an industrious man could not be kept down. Since his day the world has moved forward and the human intellect has run with mercurial swiftness into a thousand new channels. To industry must now be super-added knowledge, which comes largely from books.

To the diligent studious railroad man nothing could give him a better knowledge of his calling than the regular perusal of the pages of RAILWAY AND LOCOMOTIVE ENGINEERING, together with a close study of our standard railroad engineering publications, among which are the following:

**Railroad Men's Catechism.** By Angus Sinclair. This is a book which gives information that will be useful and acceptable to all classes of railroad men from the president to the newest brakeman. All will find in it something new and useful. All will find it worthy of study. The questions are intended to impart information covering the entire practice of train operating, and to explain all details of mechanism. The questions and answers are the outcome of Sinclair's

Locomotive Engine Running and Management, and are an enlarged code that grew up through many small forms, the best known having been the Questions and Answers prepared by the Traveling Engineers' Association. 216 pages; illustrated; ornamental cloth. Price one dollar.

"Twentieth Century Locomotives," Angus Sinclair Co., deals comprehensively with the design, construction, repairing and operating of locomotives and railway machinery. First principles are explained. Steam and motive power is dealt with; workshop operations described, valve motion, care and management of locomotive boilers, operating locomotives, road repairs to engines, blows, pounds in simple and compound engines; how to calculate power, train resistance, resistances on grades, etc. Shop tools explained. Shop recipes, definitions of technical terms, tables, etc. Descriptions and dimensions

## Railroad Books The Best Ones

### Air Brake Catechism

By Robert H. Blackall. The new revised, 1907 edition, is right up to date and covers fully and in detail the Schedule E. T. Locomotive Brake Equipment, H-5 Brake Valve, SF Brake Valve (Independent), SF Governor Distributing Valve, B-4 Feed Valve, B-3 Reducing Valve, Safety Valve, K Triple Valve (Quick-Service) Compound Pump. It is the Standard Book on the Air Brake. Contains over 2,000 Questions and Answers giving a detailed description of all the Old Standard and Improved Equipment. Price, \$2.00.

### The Walschaert Locomotive Valve Gear

By W. W. Wood. If you would thoroughly understand the Walschaert Locomotive Valve Gear, you should possess a copy of this book, as the author explains and analyzes it in a most practical manner. Price, \$1.50.

### Locomotive Breakdowns

#### and Their Remedies

By Geo. L. Fowler. Tells how and what to do in case of an accident or breakdown on the road; includes special chapters on Compound Locomotives. Better procure a copy, as it contains 800 Questions and their Answers on accidents and breakdowns. Price, \$1.50.

### New York Air Brake Catechism

By Robert Blackall. The only complete treatise on the New York Air Brake and Air Signaling Apparatus. 250 pages. Price, \$1.00.

### Combustion of Coal

#### and the Prevention of Smoke

By Wm. M. Barr. Contains over 800 Questions and their Answers on How to Make Steam. Price, \$1.50.

### Locomotive Catechism

By Robert Grimshaw. Contains 1,600 Questions and Answers on How to Run a Locomotive. The Standard Book on the subject, being written in plain language and free from mathematical formulæ and complex problems. Price, \$2.00.

### Link Motions, Valves and Valve Setting

By Fred H. Colvin. Shows the different valve gears in use, how they work and why. Piston and slide valves of different types are illustrated and explained. A book that every railroad man in the motive power department ought to have. Price, 50c.

### Train Rules and Dispatching

By H. A. Dalby. Contains the standard code for both single and double track and explains how trains are handled under all conditions. Gives all signals in colors, is illustrated wherever necessary, and the most complete book in print on this important subject. Bound in fine seal flexible leather. 221 pages. Price, \$1.50.

### American Compound Locomotives

By Fred H. Colvin. Shows all types, including the balanced compound which is now being used. Makes everything clear by many illustrations and shows valve setting, breakdowns and repairs. Price, \$1.50.

### The Railroad Pocketbook

By Fred H. Colvin. Different from any book you ever saw. Gives clear and concise information on just the points you are interested in. It's really a pocket encyclopedia, fully illustrated, and so arranged that you can find just what you want in a second without an index. Whether you are interested in Axles or Acetylene; Compounds or Counter balancing; Rails or Reducing Valves; Tires or Turn-tables, you'll find them in this little book. It's very complete. Flexible cloth cover. 250 pages. Price, \$1.00.

Send for a special circular describing these books in full. Any of these books sent prepaid on receipt of price.

### AGENTS WANTED

Write for particulars.

The Norman W. Henley Publishing Co.  
132 Nassau St., New York, U. S. A.



**RUBEROID ROOFING**

FOR  
**CARS SHOPS**  
**CABS ROUND HOUSES**

Contains no tar. Will not melt, rot, crack or corrode.  
 Not affected by extremes of temperature. Highly fire resisting.

Spark-Proof Cinder-Proof  
 Gas-Proof Weather-Proof

Write for samples and prices.

**THE STANDARD PAINT CO**  
 100 William St., New York.

Boston, Chicago, St. Louis, Kansas City, Philadelphia, Atlanta.

**Ball's Official R.R. Standard Watches**

16 AND 18 SIZE

17 and 21 Ruby Jewels, Sapphire Pallets

Ball's Improved Safety Double Roller



Are without question the finest watches that American talent and skilled labor can produce, and they are giving such universal satisfaction that we have no hesitancy in claiming that they are the best and safest railroad watch on the market.

Tests severe and numerous have proven this fact to the most critical users in all sections of the country, to which thousands of good Railroad and Brotherhood men are ready to certify.

We have an authorized agent in nearly every railroad center. Call on him for information and facts. Write us for descriptive matter.

**The Webb C. Ball Watch Co.**  
 Watch Manufacturers  
 Ball Building, Cleveland, Ohio, U. S. A.

**Patents.**  
**GEO. P. WHITTLESEY**  
 MCGILL BUILDING WASHINGTON, D. C.  
 Terms Reasonable Pamphlet Sent

of the various types of standard locomotives. The book is well and clearly illustrated and is thoroughly up to date in all particulars, fully indexed. Price, \$3.00.

"Locomotive Engine Running and Management," by Angus Sinclair, is an old and universal favorite. A well-known general manager remarked in a meeting of railroad men, "I attribute much of my success in life to the inspiration of that book. It was my pocket companion for years." Price, \$2.00.

"Practical Shop Talks." Colvin. This is a very helpful book, combining instruction with amusement. It is a particularly useful book to the young mechanic. It has a stimulating effect in inducing him to study his business. We sell it for 50 cents.

Spangenberg's Steam and Electrical Engineering has 672 pages, 648 illustrations. It may be called a complete library in one volume, and is in question and answer form; which is an easy way of obtaining useful information. Covers a wide field. Fully indexed for reference so that any subject may be readily turned to and answer found. Price, cloth, \$3.50.

The 1907 Air Brake Catechism, by C. B. Conger. Convenient size, 230 pages, well illustrated. New edition. Up-to-date information concerning the whole air brake problem, including the ET equipment in question and answer form. Instructs on the operation of the Westinghouse and the New York Air Brakes, and has a list of examination questions for enginemen and trainmen. Bound only in cloth. Price, \$1.00.

"Compound Locomotives." Colvin. This book instructs a man so that he will understand the construction and operation of a compound locomotive as well as he now understands a simple engine. Tells all about running, breakdowns and repairs. Convenient pocket-size, bound in leather, \$1.00.

"Catechism of the Steam Plant." Hemenway. Contains information that will enable a man to take out a license to run a stationary engine. Tells about boilers, heating surface, horse power, condensers, feed water heaters, air pumps, engines, strength of boilers, testing boiler performances, etc. Question and answer style, 128 pages. Pocket size, 50 cents.

"Care and Management of Locomotive Boilers." Raps. This is a book that ought to be in the hands of every person who is in any way interested in keeping boilers in safe working order. Written by a foreman boilermaker. Also contains several chapters on oil burning locomotives. Price, 50 cents.

**Boiler Scale Remover.**

Nothing in or about a steam plant cuts down the dividends, runs up the operating expense, and causes trouble without a single benefit more than boiler scale. The principal scale forming substances in

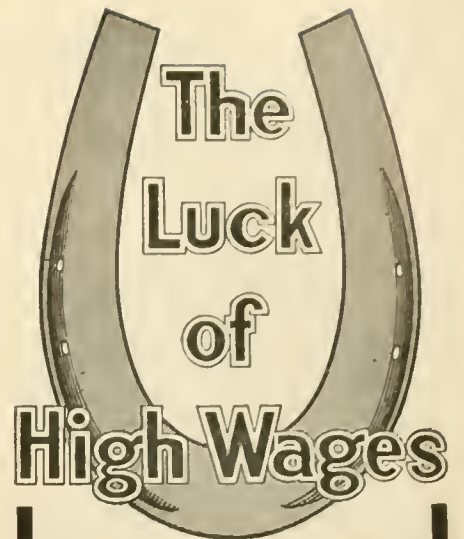

The luck of high wages is spelled with a capital P—it's P-I-U-C-K—the ability to find a practical, easy, and systematic way to secure a better position and increased earnings and the pluck to follow out that way persistently.

In this way John L. Walters, a fireman living at 822 Atchison St., Columbus, Ohio, followed the I. C. S. plan of securing a better position, and is now a locomotive engineer and has increased his earnings from \$65 to \$135 per month.

In this way Harvey Brake-man, a carpenter, of New Kensington, Pa., became an architect and increased his income from \$2.25 a day to \$5,000 a year.

In the same way YOU can increase your earnings, secure a better position and success in the easiest, most practical, quickest, and cheapest way in the world. All we ask is for you to write us and allow our experts to tell how we can adapt our system, which in 15 years has bettered the positions and earnings of hundreds of thousands of men, to your own personal needs, no matter how scant your time, money, or education may be. To secure this valuable advice free, it is only necessary to send us the coupon below. Isn't a higher position worth a postage stamp to you?

**INTERNATIONAL CORRESPONDENCE SCHOOLS**  
 Box 805, Scranton, Pa.

Please explain, without further obligation on my part, how I can qualify for a larger salary and advancement to the position before which I have marked X.

General Foreman	R. R. Con. Engineer
R. R. Shop Foreman	Civil Engineer
R. R. Trav. Engineer	Bridge Engineer
R. R. Trav. Fireman	Chemist
Locomotive Engineer	Mining Engineer
Air-Brake Instructor	Architect
Air-Brake Inspector	Bookkeeper
Air-Brake Repairman	Stenographer
Mechanical Engineer	Ad. Writer
Mechanical Draftsman	French } With Edison
Machine Designer	German } Phonograph
Electrical Engineer	Spanish }

Name \_\_\_\_\_

Employed by \_\_\_\_\_ R. R. \_\_\_\_\_

St. & No. \_\_\_\_\_

City \_\_\_\_\_ State \_\_\_\_\_

# Tate Flexible Staybolt



Strong  
Effective  
Economical

Flexibility  
Durability  
Simplicity

Holds firebox sheets securely together, and accommodates itself to the unequal expansion of the plates.

## FLANNERY BOLT COMPANY

PITTSBURG, PA., U. S. A.

Suite 308, Frick Bldg.

B. E. D. STAFFORD, - General Manager  
Write us for Reference Book

feed-water are carbonate of lime, sulphate of lime or gypsum and magnesia. These are soluble in cold water and in water of moderately high temperature, but become insoluble at a temperature of 303 degs., which corresponds to an absolute steam pressure of 70 lbs.

Scale forming substances are precipitated by heating and evaporating the water. Part of the precipitation is deposited as mud, and part settles on the tubes, crown sheets, side sheets, or any place in the boiler where these mineral substances may come in contact with iron, and form scale. Scale seriously detracts from the heat transmitting power of the tubes and sheets.

A compound that will remove scale which has already formed must go to the root of the evil. It must act in such a manner as to remove the scale, and once removed should act so as to keep the plates clean. This is the claim made for the Magic Boiler Compound now being offered for sale by the H. W. Johns-Manville Co., of New York, and we are told that "when introduced into the boiler it works its way between the scale and the iron, and causes the scale to loosen and fall off, and presents a surface to which no further sediment will adhere."

The H. W. Johns-Manville Co. have issued an interesting folder entitled "How to Clean a Boiler," which gives some valuable information on this subject. Write to the company for a copy of the folder.

### Heat Losses Due to Scale.

The Engineering Department of the University of Illinois has issued a bulletin on "The Effect of Scale on the Transmission of Heat Through Locomotive Boiler Tube." The bulletin has been prepared by Messrs. Edward C. Schmidt and John M. Snodgrass, and describes a series of experiments begun in 1900 by the railway engineering department of the university to determine the amount of heat loss due to scale thickness. Experiments were made on single tubes as well as on a locomotive boiler.

The result of all the tests show great divergence in the heat loss, due to differences in scale composition. The conclusions from the tests are summarized as follows:

That for scale of thicknesses up to 1/8 in. the heat loss may vary in individual cases from insignificant amounts to as much as 10 or 12 per cent. That heat losses increase with thickness in an undetermined ratio. That the mechanical structure of the scale is of as much or more importance than thickness in producing the loss, and that chemical composition, except in so far as it affects the structure of the scale, has no direct influence on heat transmission.

*Perfect*

Why pay more for a Car and Locomotive Cleaner, when the "PERFECT" will do the work and better at 48 cents per gallon, f. o. b. Philadelphia or Chicago?

THE MODOC SOAP CO.  
228 North Fourth Street  
PHILADELPHIA, PA.

**MICA**  
CABOOSE LAMP CHIMNEYS  
Save 50 per cent.

STORRS MICA CO.,  
R. R. Dept. Owego, N. Y.

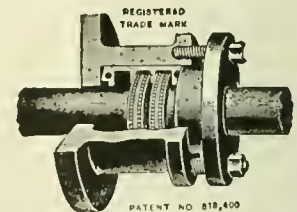

PAT. NO. 818,400  
PAT. NO. 628,177  
PAT. NO. 854,842  
PAT. NO. 854,842  
PAT. NO. 729,388  
PAT. NO. 775,186  
PAT. NO. 775,186  
PAT. NO. 775,186

### NO MORE BILLS for PACKING

No Cutting of Rods  
Less Oil. No friction

Guaranteed 3 years. 30 Days' Trial  
No Pay unless Satisfactory  
Beware of Imitations. Use the Best

Manufactured only by

**Holmes Metallic Packing Company**

Wilkes-Barre, Pa.

Send for Catalogue K

THE WASHBURN CO.

Minneapolis, Minn.

**Automatic Couplers**

For Freight, Engine and Passenger Service

## Locomotive Blow-Off Plug Valves

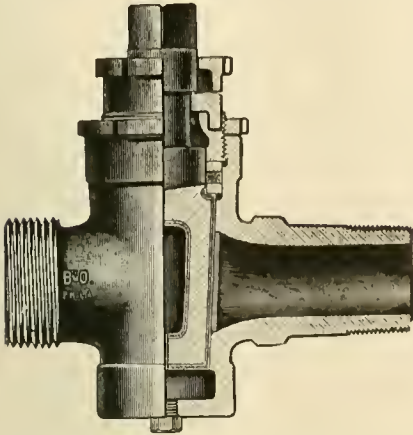

All Brass, extra heavy, with Cased Plug.  
For 250 lbs. pressure.  
Made with Draining Plug to prevent freezing.



## LOCOMOTIVE GAUGE COCKS

For High Pressure

Bordo Self-Closing Gauge Cocks, made with renewable Hard Bronze seat and disc. Opened and closed with a quarter turn. Guaranteed Steam tight under the most exacting conditions. Shanks Threaded to specifications for Locomotives.

Seats and discs replaced under pressure.

## Swing-Joints and Pipe Attachment



May be applied between Locomotive and Tender.  
These Swing-Joints are suitable for Steam, Gas, Air, Water or Oil.

Complete Booklet on Application

**L. J. BORDO CO.**  
PHILADELPHIA, PA.

### Gun Metal.

This alloy is so-called because it was at one time largely used for casting guns. It contains about 90 per cent. of copper and 10 per cent. of tin, and is one of the strongest of the copper-tin alloys. The term "gun metal" should be restricted to alloys containing about 10 per cent. of tin, but is now often used as a synonym for bronze and sometimes for triple alloys containing zinc as well as tin.—*The Foundry.*

### The Tiregraph.

The Commonwealth Steel Company, of St. Louis, Mo., have issued a neat booklet describing their clever device, the Tiregraph, which is a small portable machine used for measuring the contour of worn tires to indicate the causes of tire defects as related to improper counterbalancing, or other causes. The machine takes a record of the wear on tires, and is secured to the tool post of a driving wheel lathe in the same manner as an ordinary turning tool. The value of the record can be seen at a glance by looking at the Tiregraph, as the flat spots and high spots, their length and depth of wear, and their relation to the counterbalancing and steam admission, permit the definite determination of the causes of the variation in the wear of tires, and suggest the remedy. The Tiregraph has come to stay. Write to the Commonwealth people if you would like further information on the subject.

The Chicago Pneumatic Tool Company has recently got out two new catalogues, Nos. 23 and 24. The first of these, No. 23, is a book of more than 100 pages and is devoted exclusively to Franklin Air Compressors. It contains descriptive matter and information relating to air compressors, and is embellished with half-tone engravings of the machines and their parts. Catalogue No. 24 is also a book of more than 100 pages and fully covers the company's widely known line of pneumatic tools and appliances, including "Boyer" and "Keller" hammers, "Little Giant" drills, sand rammers and hoists. Both books are printed in colors, conveniently indexed and strongly bound, thus making them books of reference as well as catalogues. Copies will be forwarded upon request. Address Chicago Pneumatic Tool Company, Fisher Building, Chicago, or 95 Liberty Street, Chicago.

The Hicks Locomotive and Car Works, of Chicago, have made unprecedented progress in the repair of locomotives and the manufacture of coaches and cars, and to those who have not had the opportunity of visiting their establishments, we would urge upon them the desirability of procuring a copy of the new descriptive

## Homestead Valves

Straightway, Three-way and Four-way,  
and

## Homestead Locking Cocks

Are Famous the World Over

They cost more, but are worth very much more than other makes. You try them and see.



Brass, 1 1/2 in.

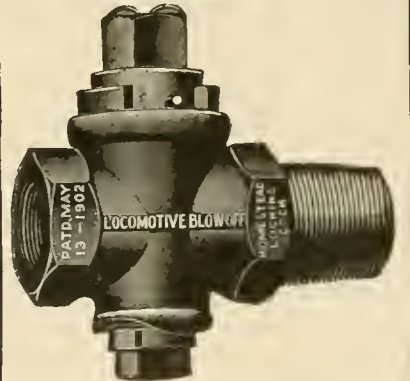

Iron Body, Brass Plug, 1 1/2 in.

**HOMESTEAD VALVE MFG. CO**

WORKS:  
HOMESTEAD, PA.      PITTSBURG, PA.

## American Locomotive Sander Company

13th & Willow Sts., Philadelphia, Pa.

Proprietors and Manufacturers

LEACH, SHESSBURGH, DEAN, SANDERS  
HOUSTON, "SHE" and CURTIS

**THE ROBERT W. HUNT & CO.**  
Bureau of Inspection, Tests and Consultation.  
1137 THE ROOKERY, CHICAGO.

66 Broadway, New York.  
Park Building, Pittsburg.  
31 Norfolk House, London, Eng.  
Inspection of Steel Rails, Splice Bars, Railroad Cars, Wheels, Axles, etc. CHEMICAL LABORATORY—Analysis of Ores, Iron, Steel, Oils, Water, etc. PHYSICAL LABORATORY—Test of Metals, Drop and Pulling Test of Couplers, Draw Bars, etc. Efficiency Tests of Boilers, Engines and Locomotives.

# One Year and Eleven Months' SERVICE

WITHOUT REPACKING, ON

## High-Pressure Locomotives

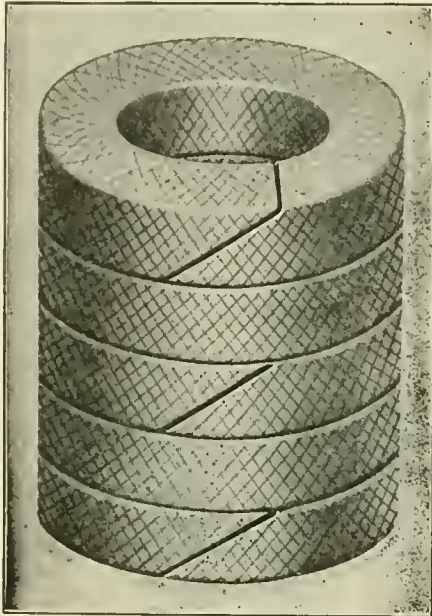

Style 300 TV.

A throttle failure is an absolute impossibility where Crandall's Throttle Valve packing is used.

IT WILL NOT BLOW OUT

### Crandall Packing Co.

FACTORY AND GENERAL OFFICE  
PALMYRA, - - NEW YORK

BRANCHES

New York  
136 Liberty St.

Cleveland  
9 So. Water St.

Chicago  
52 West Washington St.

## Directory of Railways of the World

The Universal Directory of Railway Officials, published in London, contains a list of the entire railroads of the world, with physical particulars and names of all officials.

Send Your Order Now

for the 1907 edition.

Price \$4.00 Prepaid

**A. FENTON WALKER**  
Sole Representative for U. S.  
148 Liberty St. New York

catalogue issued by the company last month, and which may be had on application by mail addressed to them, Fisher Building, Chicago. The story of the growth of the firm is particularly interesting, and is an evidence of the prosperity of the country. It was the sudden blossoming of a small repair shop into a gigantic factory employing thousands of skilled workmen. Ten years ago Mr. F. M. Hicks leased a small building at Chicago Heights and opened a shop for the repair of locomotives. His work was thorough and was immediately appreciated by the leading western roads. Locomotives literally rolled into his hands, and to these were added cars and coaches, to accommodate the manufacture and repair of which new shops were erected, covering 58 acres. The largest cars ever constructed have been built by the company, and the Gold Medal was awarded to them at St. Louis in 1904. The repair of locomotives has kept pace with car construction and a high class of medium weight new locomotives is also being constructed at the company's works. The mechanical equipment is of the best.

The Flannery Bolt Company have a neat and artistic method of calling attention to the growing popularity of the Tate Flexible Staybolt. In a finely printed folder the merits of the flexible bolts are set forth in a convincing way. We gather in a few words that the bolts are already in use on ninety railroads and over a million are now in service. In reading the folder the general opinion seems to be that in high pressure boilers the use of Tate bolts helps to reduce the number of fractures. A copy of the folder may be had on application by mail to the company's office, 308 Frick Building, Pittsburgh, Pa.

Owing to the rapid increase of their business the Armstrong Bros. Tool Co., of Chicago, "the tool holder people" have been compelled to make further additions to the large modern plant which they erected about two years ago. The additions consist of two buildings of steel and brick construction, one 50 ft.x105 ft., the other 40 ft.x105 ft., with brick smokestack 60 ins. in diameter and 115 ft. high. In these buildings the company is now installing a modern power plant of 300 h.p., consisting of two 150 h.p. water tube boilers equipped with automatic stokers, direct connected engine and generator, etc., and an up-to-date drop forge department of large capacity with steam drop hammers and other high grade equipment, including a complete die shop with machine tools especially adapted to that work. The machinery is now being set in position and it is expected that it will be in operation about October 1st.

### THE TANITE CO. seeks the support of Railroaders because:

The man who uses a TANITE wheel will find it safe. Because pay for a TANITE wheel secures the greatest productive capacity. Because TANITE MILLS EMERY is mined in America and appeals to all who earn wages in America. Because TANITE grinding machines are practical.

THE TANITE CO. sells Emery, Solid Emery Wheels, Buffing Lathes, Guide Bar Grinders, Car Brass Grinders, Bench and Column Grinders, Surfacing Machines, Open Side Emery Planers, Saw Gummers, Automatic Planer Knife Grinders, Diamond Tools, Polishing Paste for Brass and Nickel, Emery Wheel Cutters and Dressers.

The Tanite Co builds special machines for special wants

### THE TANITE CO. STROUDSBURG, PA.

## THE UNION SWITCH & SIGNAL COMPANY

CONSULTING AND MANUFACTURING SIGNAL ENGINEERS

Automatic Block Signals—Electric and Electro-Pneumatic

Interlocking — Electric, Electro-Pneumatic and Mechanical

Electric Train Staff Apparatus

General Offices and Works at SWISSVALE, PA.

DISTRICT OFFICES:

NEW YORK - - 143 Liberty Street  
CHICAGO - - - Monadnock Block  
ST. LOUIS - - - Frisco Building

## Oliver Lippincott Photographer

20 John Street, New York

Process and Mechanical Prints

Perfect reproduction from Tracings, Black Lines, White Paper, any size, for Specifications and Estimates.

# The Twentieth Century Master Mechanic

Won't use Solid Mandrels.  
Cost too much, take up too much room and don't give satisfaction.

## Nicholson Expanding Mandrels

Take everything from 1 to 7 inch holes. Take up little room—always ready and you can buy four sets for the cost of one of the solid kind.

## Are You Using Them?

Catalogue tells you more about them.

W. H. Nicholson & Co.  
Wilkesbarre, Pa.

# TOOL STEEL

Die Blocks  
Steel Forgings

First Prize awarded at the Louisiana Purchase Exposition, at St. Louis, for our TOOL STEEL when placed in competition with the best makes in England and Germany.

Write for Information and Prices.  
Specify McInnes Tool Steel when ordering.

McINNES  
STEEL CO.  
CORY, PA.

### Six-Wheel Switching Locomotives.

The American Locomotive Company have just issued the ninth of their series of pamphlets covering the standard types of locomotives. As the title indicates, this number of the series is devoted to 6-wheel switching locomotives and contains half-tone illustrations and the principal dimensions of 26 different designs of this type. The engines illustrated range in weights from 102,000 to 176,500 lbs., and are adapted to an extensive variety of service conditions. A copy of this pamphlet may be had by applying to the company.

### Oriental Machine Shops.

A Consular report from Smyrna, one of the oldest and most celebrated cities in Asia Minor, states that up to 1857 there was not a factory of any kind in Smyrna which manufactured steam engines or machine supplies. The completion of the Aidin Railway, and the introduction of cotton-growing, which created a demand for iron products, gave an impulse to this industry with the result that there are at present three large machine shops, and a number of smaller factories in Smyrna. The annual output is not known, but is greatly on the increase and the field for machines of every description is becoming a large one.

The Falls Hollow Staybolt Company, of Cuyahoga Falls, Ohio, are now erecting a new mill of three times the capacity of their existing plant. This increase has been found necessary by the steady growth of their business. The company manufactures not only the hollow staybolt iron, but solid staybolt iron of high grade as well as steel bars and supply an extensive trade in the United States, Canada, Mexico and foreign countries. One of the claims made by this company for the hollow form of staybolt is that air constantly passing through the bolts tends to keep them comparatively cool, at their inner ends, and the tell-tale hole through the bolt will at once reveal a fracture of the bolt anywhere along its length. The company will gladly furnish full information concerning their products to any one asking for it. The enlargement of their manufacturing facilities is a gratifying evidence of their prosperity.

The Bliss Electric Car Lighting Company, of Milwaukee, Wis., report having received an order from the Pullman Company for the Bliss Axle Light Equipment, to be applied to all Pullman Private Cars. They also announce having lately received an order from the Baltimore & Ohio to equip the Royal Blue Line Limited trains with the Bliss system of electric lights and fans.

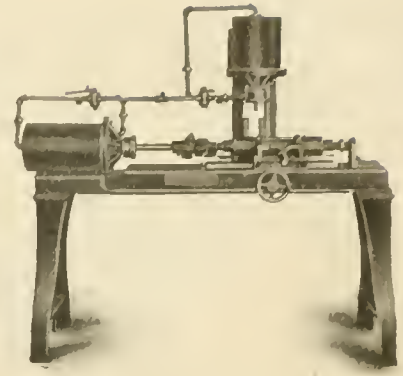

Above Cut Represents the TWENTIETH CENTURY OUTFIT

For mounting air signal and steam hose. It does it all, mounts new hose and applies the bands. Cuts the bolts on old hose and pulls them from their fixtures. An equipment for each set goes with every outfit. Its work is so rapid and perfect that other methods are archaic and expensive in comparison.

BUKER & CARR MFG. CO.  
Office, Fairview Heights, No. 19  
Rochester, N. Y., U. S. A.

There is a valve oil can for locomotive use which is designated by the letter "J" from the initial of the makers, the Johnson Manufacturing Co., of Urbana, O. The oil can has a shut-off valve close to the handle so as to save waste and the can is a neat looking and well made article. The company will gladly submit blue print of this oil can and give information concerning its use and manufacture, with price. They will be glad to answer inquiries concerning their complete line of heavy railroad tin and galvanized iron ware if you drop them a line.

## CONTENTS.

*Fast Trains in America (the N. Y. C.)	393
Early Locomotive Building	394
Creditable Performance	397
*Curiosities and Freaks	398
*Signals on the Pennsylvania	406
Transportation and Space	407
Book Notice—Development of the Locomotive, by Angus Sinclair	410
*Subaqueous Tunnel at Detroit	411
*150-Ton Car for Bethlehem Steel Co.	416
Machine Shop Reminiscences—Shaw's Closet	423
*Force Feed Lubricator for Locomotives	427
*Gravity Tank Hose Coupling	429
Departments:	
*Patent Office	396
*General Correspondence	401
Correspondence School	413
Questions Answered	415
*Air Brake	417
*Electrical	419
Personals	425
Locomotives:	
*Baldwin De Glehn for France	397
*Curiosities of Design	398
*2-S-o for the Tonopah & Goldfield	405
*Mallet Compound for the Erie	421
*Shay, Geared for the C. & O.	427
Editorials:	
Causes of Boiler Explosions	408
Instruction in Signaling	408
Walsehaerts Valve Gear	409
High Speed Gasoline Road Motors	409
Nickel Uncertain Material for Rails	409

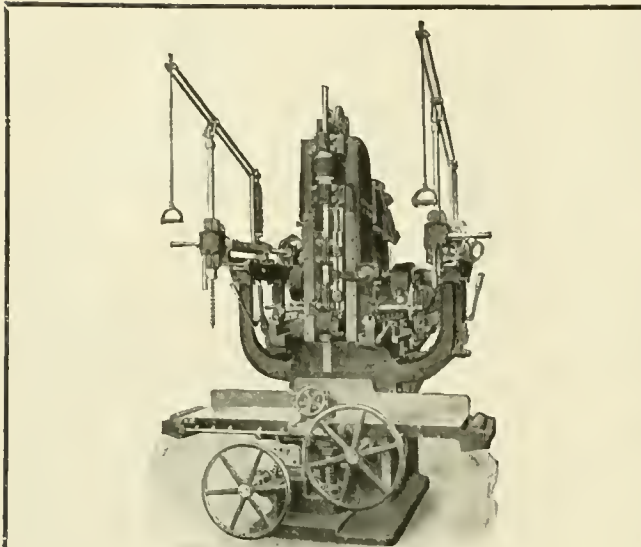

No. 214, Vertical Hollow Chisel Mortiser.

**OUR LATEST**

Our latest production in mortisers was designed especially for heavy car work and bridge construction, and is furnished with or without auxiliary boring attachments.

The housing is securely gibbed to the frame, moving transversely by hand-wheel to bring chisel into position.

The chisel ram is gibbed to the housing and has a vertical travel of 18 inches, and gets its reciprocating motion from a rack and pinion operated by friction pulleys, giving a constant and positive drive.

Detailed description given in circular. Write for it.

**J. A. FAY & EGAN COMPANY**  
445 West Front Street CINCINNATI, OHIO

**Two Oil Rooms**

Which do you prefer?

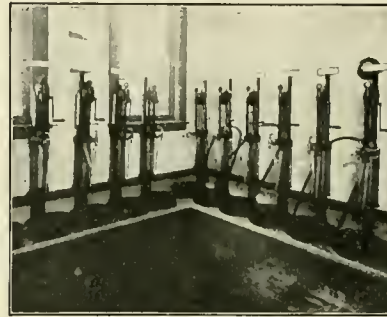

A Bowser Oil Room

The one, expensive, dirty, dangerous and inconvenient.

The other, the Bowser, paying for itself in actual saving—clean, perfectly safe and the most convenient possible to devise.

The contrast in appearance as shown here is no greater than the contrast the Bowser

System of Oil Storage effects in expense, protection and adaptability as compared with other arrangements.

Designed for railroad use and adopted as standard by over 20 railroad systems.

Explained in Bulletin D. Send for it.

**S. F. Bowser & Co., Inc.**  
Fort Wayne, Ind.



Not a Bowser

**INDEX TO ADVERTISEMENTS.**

	PAGE.
Acme Machinery Co.....	Front Cover
Ajax Metal Co.....	4th Cover
American Balance Valve Co.....	4th Cover
American Brake Shoe Co.....	17
American Locomotive Sander Co.....	433
American Locomotive Co.....	10
American Steam Packing Co.....	16
Armstrong Bros. Tool Co.....	2d Cover
Armstrong Mfg. Co.....	16
Associated Expanded Metal Companies.....	7
Audel, Theo., Co.....	—
Baker, Wm. C., Heating and Supply Co....	17
Baldwin Locomotive Works.....	11
Ball, Webb C., Co.....	431
Ball Chemical Co., The.....	24
Barnett, G. & H., Co.....	2d Cover
Bettendorf Axle Co.....	4
Bliss Elec. Car Lighting Co.....	4
<b>BOOKS.—</b>	
Air Brake Chart.....	13
Development of Locomotive Engine.....	8 and 9
Miscellaneous Books.....	21
Twentieth Century Locomotives.....	4
Railroad Men's Catechism.....	2
Bordo, L. J., Co.....	433
Boston & Maine R. R.....	15
Bowser, S. F., & Co., Inc.....	436
Buker & Carr.....	435
Carpenter, The J. M., Tap & Die Co.....	11
Central R. R. of New Jersey.....	28
Chalfonte Hotel.....	19
Chapman Jack Co.....	5
Chicago Pneumatic Tool Co.....	7
Cleanola Co., The.....	24
Cleveland City Forge & Iron Co.....	4th Cover
Cleveland Twist Drill Co.....	4th Cover
Columbus Pneumatic Tool Co.....	24
Commercial Acetylene Co.....	3
Consolidated Railway, Electric Lighting & Equipment Co.....	16

Commonwealth Steel Co.....	25
Crandall Packing Co.....	434
Dart, E. M., Mfg. Co.....	4th Cover
Davis, John, Co.....	23
Detroit Lubricator Co.....	17
Detroit Seamless Tubes Co.....	3
Dixon, Joseph, Crucible Co.....	428
Dressel Rly. Lamp Works.....	20
Falls Hollow Staybolt Co.....	4
Fay & Egan Co., J. A.....	436
Flanders, L. B., Machine Works.....	7
Flannery Bolt Co.....	432
Franklin Mfg. Co.....	12
Frost Railway Supply Co.....	2d Cover
Galena Signal Oil Co.....	26
Garlock Packing Co.....	4
General Electric Co.....	1
Gold Car Heating Co.....	429
Golden-Anderson Valve Co.....	12
Goodrich Rubber Co.....	23
Gould Coupler Co.....	11
Greene, Tweed & Co.....	2d Cover
Griffin & Winters.....	4
Hammett, H. G.....	4th Cover
Hancock Inspirator Co.....	16
Hendrick Mfg. Co.....	11
Henley & Co.....	430
Hicks, F. M., & Co.....	14
Hoffman, Geo. W.....	11
Holmes Metallic Packing Co.....	432
Homestead Valve Mfg. Co.....	433
Hotel Traymore.....	15
Hunt, Robert W., & Co.....	433
International Correspondence Schools.....	431
Independent Pneumatic Tool Co.....	22
Jenkins Bros.....	4th Cover
Johns-Manville, H. W., Co.....	14
Kinnear Mfg. Co.....	2d Cover
Lackawanna R. R.....	14
Latrobe Steel & Coupler Co.....	11
Lima Locomotive Works.....	26
Lehigh Valley R. R.....	13

**LOCOMOTIVE CHARTS:—**

Atlantic Type.....	28
Lippincott, Oliver.....	434
Locomotive Publishing Co., Ltd.....	7
Long & Allstater Co.....	5

McConway & Torley Co.....	17
McCord & Co.....	2d Cover
McInnes Steel Co.....	435
Modce Soap Co.....	432
Morse Twist Drill Co.....	—
Nathan Mfg. Co.....	14
National Acme Mfg. Co.....	15
National Malleable Castings Co.....	4th Cover
New York Central R. R.....	19
Nicholson, W. H., & Co.....	435
Niles-Bement-Pond Co.....	12
Norwalk Iron Works.....	14
Otto Gas Engine Works.....	4th Cover
Pennsylvania R. R.....	27
Pittsburgh Crushed Steel Co.....	4th Cover
Pittsburgh Spring & Steel Co.....	18
Porter, H. K., & Co.....	10
Pratt & Whitney.....	8
Pressed Steel Car Co.....	16
Prosser, Thos., & Son.....	20
Pyle Nat'l Elec. Headlight.....	18
Railway Materials Co.....	2d Cover
Ralston Car Co.....	22
Revere Rubber Co.....	3d Cover
Rogers Locomotive Works.....	10
Rue Mfg. Co.....	1
Safety Car Heating & Lighting Co.....	5
Saunders, D., Sons.....	20
Sellers, Wm., & Co., Inc.....	20
Sipe, Jas. P., & Co.....	18
Smooth-On Mfg. Co.....	14
Standard Car Truck Co.....	2d Cover
Standard Coupler Co.....	17
Standard Paint Co.....	431
Standard Steel Works.....	11
St. Louis Car Co.....	18
Star Brass Mfg. Co.....	5
Starrett Co., L. S.....	21
Storrs Mica Co.....	432
Symington, T. H., & Co.....	4
Tabor Mfg. Co.....	13
The Tanite Co.....	434
Underwood, H. B., & Co.....	7
Union Switch & Signal Co.....	434
Vanduzen Co.....	25
Vulcan Iron Works.....	10
Walker, A. Fenton.....	434
Walworth Mfg. Co.....	2d Cover
Washburn Co.....	432
Watson-Stillman Co.....	4th Cover
Westinghouse Air Brake Co.....	6
Westinghouse Electric & Mfg. Co.....	7
Whittlesey, Geo. P.....	431
Wiley, John, & Son.....	435
Wolfe Brush Co.....	1
Wood, R. D., & Co.....	5
Zeller, Geo. A.....	3



# Railway and Locomotive Engineering

Copyright by Angus Sinclair Co.—1907

A Practical Journal of Railway Motive Power and Rolling Stock

Vol. XX.

136 Liberty Street, New York, October, 1907

No. 10

## The Pennsylvania Special.

When one says that the famous Pennsylvania Special, No. 29, goes from New York to Chicago in a little over 1,000 minutes it sounds as if the cities must have been drawn closer together in some mysterious way. There

son river from Twenty-third street in New York, and getting ready to start. This bit of water trip is not, strictly speaking, train mileage.

Six powerful Atlantic type engines are required to haul this train over the road, and changes are made at Harris-

of the performance of the iron horse.

This taking out of the hour at Pittsburgh is an interesting fact. The idea of using standard time all over this continent is for the convenience of the public, and to do it North America has been divided into a series of belts or



EIGHTEEN HOUR TRAIN ON THE PENNSYLVANIA RAILROAD.

is, of course, no mystery about it, for the train covers the full 912½ statute miles which separate Gotham from the Windy City in exactly 18 hours. It travels, therefore, at an average speed of 51.6 miles an hour, and this is something over 75 feet a second. As a matter of fact the train takes 17 hours and 41 minutes to make the run from Jersey City to Chicago, the odd 19 minutes being consumed in crossing the Hud-

burg, Altoona, Pittsburgh, Crestline and Fort Wayne. The average run for each of the engines is over 150 miles, the shortest being 117 and the longest 195 miles. The train leaves New York on Eastern standard time and arrives in Chicago on Central standard time. The hands of the clock are put back one hour at Pittsburgh to make this change, and though the hour is dropped from the timetable at this point, it does not come out

strips running north and south, and measuring everywhere 15 degrees wide, or at the equator something over 1,035 miles. The earth turns from west to east at this rate each hour, and in order to make a good working system for the inhabitants of the various cities and towns in the country the clocks are set approximately one hour slower from east to west every 15 degrees. The difference in time between New York and

Chicago is about 54 minutes, but it has been arranged for convenience at exactly one hour. If you traveled by No. 29 on the Pennsylvania Railroad and did not alter your watch at Pittsburgh you would find that you had apparently

on time. This is an excellent performance, through rain and shine, snow and cold.

Our frontispiece this month shows the "Eighteen-hour train," as it is often called, running at full speed over the

are too apt to be impatient of reasoning; they say they want facts, while they forget that to use facts aright is the highest exercise of reason. But we are not now to press the blame on both sides.

An old French diplomatist is credited with having said that language was a means of concealing men's thoughts. We don't think the remark cost him much observation, for it was founded in too common an experience. Old Talleyrand might have added that language was often used for filling the place of thoughts, and, furthermore, that it not only needed the best motives, but some skill even to make it express men's thoughts.

To our mind, one of the worst perversions to which language is liable is the use of its abstruse or profound terms before men thirsty for information. The great motive for this perversion is the desire on the part of writers to show how much they know. They wish to establish conclusions upon their own authority and not upon reasoning which their readers can understand. It is clearly an insult to a man's understanding to attempt to force upon his belief a professed fact, the evidence of which he cannot see or comprehend. Everybody acknowledges, as we believe, that scientific subjects stand in

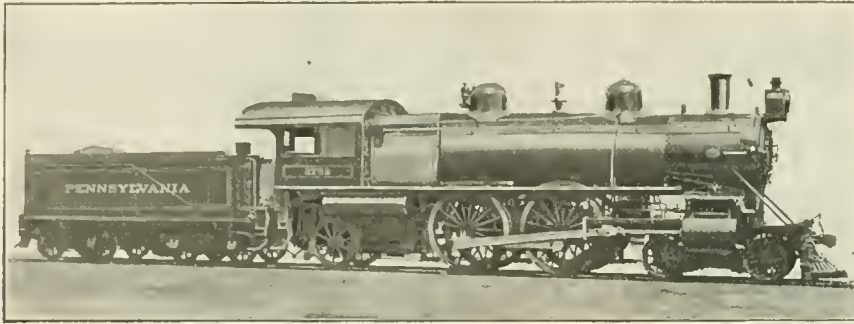

ATLANTIC TYPE PASSENGER ENGINE USED ON THE PENNSYLVANIA.

arrived at 9:45 A. M., while the Chicagoans you met would be behaving as if it were only 8:45 in the morning. On the Pennsylvania special running in the opposite direction, that is No. 28, you would start on Chicago time and find yourself an hour too slow in New York, hence the hour shown on the time table as having been put in at Pittsburgh is simply the necessary putting ahead of the hands of the clock, and does not alter the actual number of minutes required for the engines to pull the train.

One of the objects which the company had in view when this train was put on was to start from the terminal stations as late as possible in the business day and arrive in time for the next day's work at the usual hour for beginning. Speaking of the train, the passenger department of the road say in one of their illustrated folders:

"The equipment supplies all the comforts of the modern hotel and the conveniences of the club. There is a barber, bath and smoking room for the men; a maid and an observation parlor for the ladies. A stenographer executes without charge the wishes of correspondents. The dining car service, which is available at the generally accepted hours for meals, is maintained at the highest standard in every particular. Apart from the usual accommodations afforded by Pullman cars, the drawing rooms and state rooms of the special offer the exclusiveness of one's home or office. On account of the high grade of the service and the fast schedule, an extra fare over and above the price of the tickets and the usual Pullman rates is charged."

The published record of these trains shows that for the year ending June, 1906, the west bound, No. 29, ran for 365 days with 89.8 per cent. of the trains on time, and that the east bound, No. 28, had, in the same year, 85.2 per cent.

heavy railed, stone ballasted, well drained track of the Pennsylvania system, and, like Kipling's Purple Emperor, "laying the miles over his shoulder as a man peels a shaving from a soft board."

#### Highflown Writing.

The following extract from the works of Zera Colburn is interesting at the present day. One might almost think he had the sensational daily press of our own time in mind when he wrote:

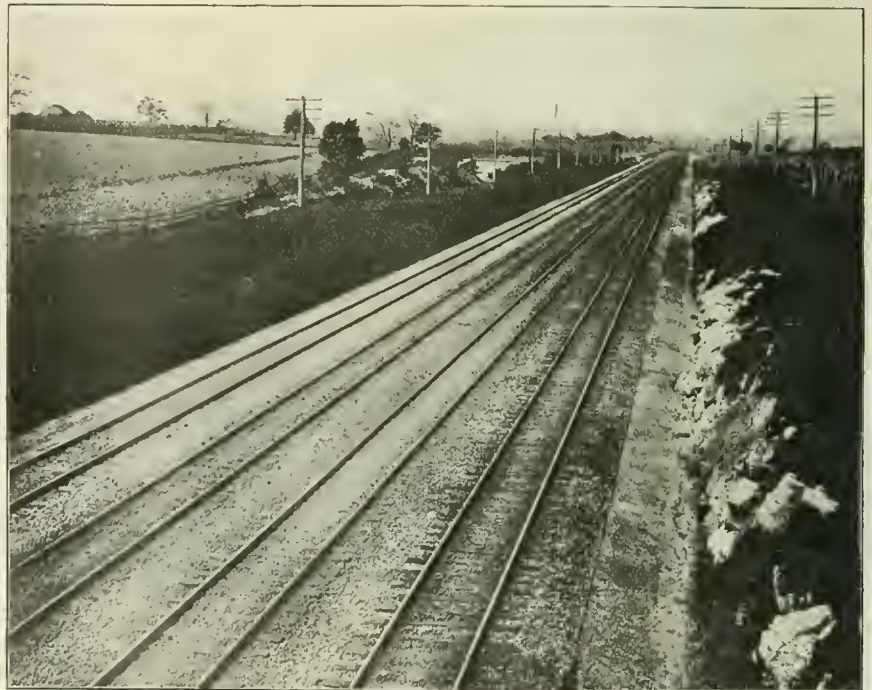

VIEW OF PENNSYLVANIA RAILROAD TRACK.

"The great reason why so much of the stilted scientific writing of the day is thrown away upon practical men is simply that it takes too much previous preparation to understand it. Yet we are not going to say that no share of blame attaches to practical men. They

the greatest need of popular explanation. There has been then a stumbling block in the way, else the need could not have been so great. It is in scientific subjects especially wherein writers have shown the greatest contempt for their readers' understandings.

The purpose of facts in practical science is practical use. Who, then, will go to the cost and toil of testing a professed fact until he understands it? Why, then, do not scientific writers as a class make their descriptions and illustrations rational and intelligible? Keep first principles and elements more in view? It is as unworthy an evasion of duty as a writer can commit to presume upon the qualifications of his readers and stuff off a parade of profound theories when he cannot even show an instance of their practical application. He thus takes to himself the largest possible opportunity for humbug, and in the absence of proof of his sincerity it is to be presumed that the occasion begets the act.

Unless we should single out and

pupil a present of the book which stands most ahead of your description."

#### The Quebec Bridge.

The collapse of the Quebec Bridge is the most appalling disaster in railroad construction that has occurred since the fall of the Tay Bridge at Dundee in Scotland in 1879. The new bridge which was being built across the St. Lawrence River six miles above Quebec was looked upon by engineers as a model of perfection in design and construction. A commission appointed by the Canadian government is at work determining the cause of the breakage in the work and doubtless much that is valuable to the engineering world will be learned from the ruin of the great work.

In December, 1905, we published in the

proach spans each 210 ft. long, then two anchor arms each 500 ft. long and two cantilever arms measuring 562½ ft. in length, and one suspended truss span 675 ft. long. The main posts were 400 ft. above the water level and the central connecting work between the two suspended extensions was 150 ft. above the river at high tide. This enormous work required a weight of steel amounting to 38,500 tons.

The work was completed as far as the southern side of the river was concerned, the complete structure extending 675 ft. from the southern pier towards the center of the river. On the northern side the structure had been completed as far as the main post or pier and abutments and arrangements were in progress to project the work on the northern side as rapidly



RUINS OF THE CANTILEVER BRIDGE OVER THE ST. LAWRENCE AT QUEBEC.

show up a specimen of such writing we might be thought to be too vague and general in our strictures. We think we can illustrate our point, however, in a manner quite to the purpose and without being unnecessarily offensive to individuals.

Single out a workingman engaged upon some part of a machine which he ought to understand. Ask him a single question involving a simple, natural principle. If he does not understand it, see by the watch in how many hours you will have him say that he does understand it fully. If you do not exhaust a greater stock of illustrations and reasoning than you ever saw expended on the same subject in a "scientific treatise," then make your

pages of RAILWAY AND LOCOMOTIVE ENGINEERING a general description of the plan of the proposed bridge. We reproduce the illustration of the completed design. The work had proceeded steadily with the exception of the months of December and January, when on account of the intense cold and also as the daylight does not exceed five or six hours little could be accomplished at that season of the year. As will be noted, the proposed bridge is of the cantilever design. The main span would have been 1,800 ft. in length, surpassing the main span of the Forth Bridge by 90 ft., and this would have made it the longest span, when completed, of any bridge in the world.

The total length of the bridge between abutments was 3,220 ft. and consisted of two deck truss ap-

as possible to meet the southern extension. The uncompleted space amounted to 1,125 ft., so it will thus be seen that although the loss is enormous it does not amount to much more than one-third of the entire proposed structure. About 15,000 tons of steel fell, and it need hardly be stated that this material when recovered is entirely useless in the reconstruction of the work.

It appears that at the time of the collapse a gale of wind was blowing at about 30 miles an hour. A locomotive with a heavily loaded train of cars was approaching the outer edge of the projected span. The main traveller was also run out to the extreme end of the work, so that the superincumbent weight of the structure was considerably augmented, but the evidence as far as has been gath-

ered does not show that any undue weight on the extended work was the cause of the breakage. Excessive weight at one end of the cantilever would cause an overturning of the structure, whereas the collapse was vertical. It may be noted that as early as May of the present year several rents were observed by workmen in the chord members, and it is remarkable that little or no attention was given to important fractures in the plates. Doubtless the commission will place the responsibility where it properly belongs, and it should be an easy matter pointing to the official who allowed added weight to be placed on structures where indications of weakness were apparent to ordinary workmen.

In this connection it is to be regretted that the officials have not acted with that degree of promptitude essential to safety of great enterprises. Several days before the disaster the resident engineer was

#### Anecdote About the Bell Cord.

One of the oldest railways in the country is the Philadelphia, Wilmington and Baltimore, now known as the Philadelphia, Baltimore & Washington, which opened in 1837. The first schedule contained one passenger train, which went to Baltimore one day and came back the next, which was considered a remarkable feat in fast travel. When a train a day each way was placed in service the people of the two cities served concluded that the acme of convenience in transportation had been reached. Next to the president of the railway the most important functionaries were the engineer and the conductor. It was a question whether or not the head of the line was considered a subsidiary official in popular estimation to the men who ran the train, but Robert Fogg, who pulled the throttle, and John Wolf,

Wolf hotly declared that he had signalled to stop, but Fogg retorted that he would stop when and where he pleased, and that, too, without any reference to orders from the conductor, whom he did not regard as his superior in the management of the train. The altercation grew very heated, and Wolf invited the engineer from the cab to settle the matter, and the challenge was quickly accepted.

Passengers and a group of men who had gathered at the station to see the train come in formed a ring about the combatants, but the fight did not last long, as Wolf proved by far the superior artist with his fists, and with a few blows made it almost impossible for the engineer to see sufficiently to complete his run; but Fogg admitted that he had been fairly beaten, and the supremacy of the conductor on a railway train was settled.

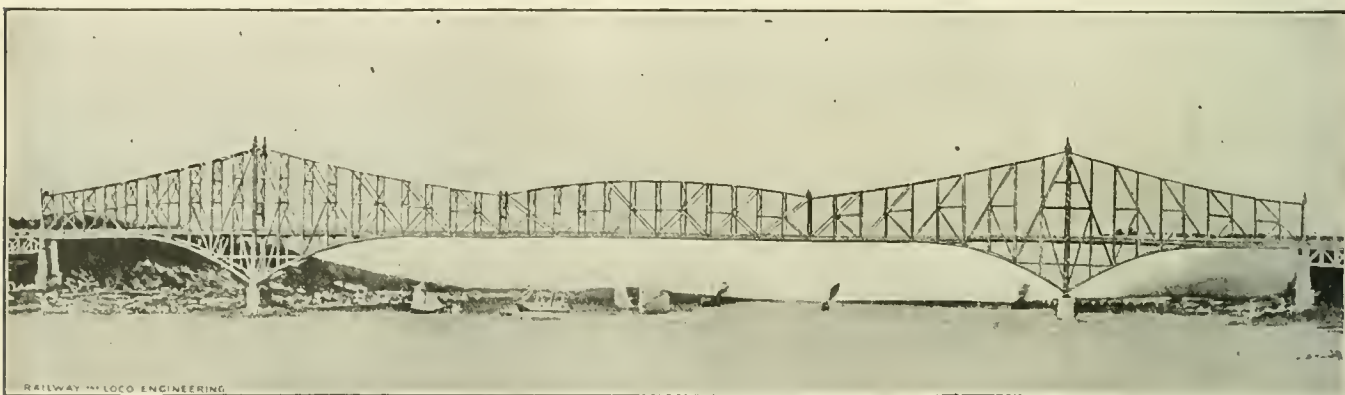

DESIGN OF QUEBEC BRIDGE OVER THE ST. LAWRENCE RIVER.

notified that a chord member in the third panel had buckled.

A visit to New York had to be made. A consultation had to be held. A telegram ordering the work to be stopped was delayed. The telegram lay on the desk of the chief engineer for several hours awaiting his action. Ninety men kept on with their work and of these eighty-four went down to their death in the awful ruin.

The river channel is not seriously obstructed by the wreckage, but operations will likely be suspended on the structural work till next year.

#### Savage Way of Making Vacancies.

A strange condition exists on the Transcaucasian Railways of Russia that greatly magnifies the hazards of railway life. A bulletin has been issued by Col. Neigebauer, director of the eastern lines, saying that in six months of this year 30 officers of the Transcaucasian Railways have been murdered. The belief is expressed that the officials were put out of the way to make room for others waiting for promotion and not by political assassins. As a remedy the director has arranged that all vacancies caused by murder shall be filled by men from distant divisions.

who collected fares, won the deference of the public because of their high and responsible duties.

Fogg, an Englishman, had all the tenacity of opinion of his race; Wolf, an American, had the ingenuity of the Yankee, and, seeing the need of some method by which he could communicate with the engineer, devised the scheme of running a cord through the cars to the locomotive. As the engine was a wood burner, Wolf fastened one end of the cord to a log, which was placed on the engineer's seat and was pulled to the floor when the conductor desired to signal for a stop.

Fogg resented what he considered on interference of his rights on the platform of the locomotive, and on the first run out with the new device paid no heed to the displacement of the log from the seat when the conductor desired to take on a passenger from a farm near Gray's Ferry, but sped on over the bridge and did not deign to bring his engine to a stop until Blue Bell station, on the south side of the Schuylkill, had been reached. Then he demanded to know of Wolf why he had been jerking that log all about the locomotive.

As the log signal was crude and ineffective, Wolf devised the use of a bell on the locomotive, and this method was soon adopted by all of the American railways. Then a code of signals was adopted, and these remain practically to this day. The only change in the bell-cord is that by use of the air from the brake system a whistle has superseded the bell in the locomotive cab.—*Philadelphia Public Ledger*.

#### Things Without Friends.

There are two or three things on which there is standing conflict between railroad companies and their employees, although there is no pronounced disagreement. There may be some engineers who favor the pooling system of using motive power, but we never met any of them; there may be machinists enamoured of the piece work system for repairing locomotives, but their voices never sounded within the hearing of our representative.

We may add that we never heard of an engineman who was an over admirer of compound locomotives. Such people may be roaming around, but their views are very little in evidence.

**Consolidation for the C. & O.**

Our illustration shows a Chesapeake & Ohio simple consolidation engine built at the Richmond shops of the American Locomotive Company. The engine was part of the company's exhibit at the Jamestown Exposition this year. The engine weighs in working order 202,800 lbs. The cylinders are 22x30 ins., and piston valves are used.

In 1904, at the time of the Louisiana Purchase Exposition at St. Louis, the Walschaerts valve gear was a new feature in American locomotive practice, and out of twelve locomotives exhibited by the builders at that exposition, only one, the Baltimore & Ohio Mallet Compound, was equipped with this type of gear. At the present time the Walschaerts valve gear is used on many of the great trunk lines in the country. The Chesapeake & Ohio engine is equipped with inside admission valves,

wide. It is 70¼ ins. deep at the front and 59½ ins. at the back. The roof and crown sheets slope toward the back about 2¼ ins.; the back sheet slopes forward 20 ins., and the mud ring slopes down to the front 12 ins. and the throat sheet slopes forward 13 ins. There is a steam and water space above the crown sheet of about 22 ins. The dome measures 31½ ins. inside diameter, and has a 24-in. opening into the boiler. It is 20 ins. high. The grate area is 53 sq. ft., and this gives a ratio of grate to heating surface of about as 1 is to 62. The tank is carried on a structural steel frame and has a water bottom. The capacity of the tank is 7,500 U. S. gallons, and 12½ tons of coal is carried. A few of the principal dimensions are appended for reference:

Wheel base—Driving 16 ft.; total engine, 24 ft. 3½ ins.; engine and tender, 56 ft. 5¾ ins. Axles—Driving journals, main, 10x12 ins.; others, 9x12 ins.; engine truck, 5½x10 ins.; tender, 5½x10 ins. Boiler—Thickness ring, first, 27-32 in. and ¾ in.; throat, 11-16 in.;

**Curiosities of Locomotive Design.\***

**THE FONTAINE FREAK.**

In 1881 the Grant Locomotive Works, of Paterson, N. J., built a locomotive, Fig. 11, designed by Eugene Fontaine, of Detroit, which excited great attention for a few years owing to the radical departure from established practice in designing locomotives. Fontaine built his engine with the driving wheels above the boiler, so arranged that their tread pressed upon and transmitted motion to the carrying wheels by frictional contact. The reasons given by the designer for building this form of an engine were: "The question of faster speed in railroad travel is one that is now attracting attention on the part of the public, who demand it, and of the railroads, who are anxious to meet the demand.

"It is well known that to increase speed in locomotives, as now used, be-



CHESAPEAKE & OHIO SIMPLE CONSOLIDATION ENGINE.

J. F. Walsh, Supt. of Motive Power.

American Locomotive Co., Builders.

the connection of the valve stem with the combination lever is below the radius bar. In this design the link is supported in a bracket bolted to the back of the guide yoke and the reversing shaft is placed between the second and third drivers, and its arm is directly connected with the radius bar by means of a slip joint.

All the wheels are flanged and they are almost equally spaced. The pony truck and the two leading pairs of drivers are equalized together and the main and the trailing drivers are equalized together. The driving wheels are 57 ins. in diameter. The calculated tractive effort of the engine is about 43,300 lbs., and with 180,600 lbs. on the drivers the ratio of adhesion is 4.1.

The boiler is a straight top one, made in two barrel courses, the smaller being 76 11-16 ins. in diameter. The heating surface is in all 3,281 sq. ft., of which the 401 tubes, each 14 ft. 6½ ins. long, contribute 3,038 sq. ft., and the firebox 143¾ sq. ft. The firebox of this engine is 106¼ ins. long and 71¾ ins.

dome, 5½ in.; front tube, ½ in.; roof, 9-16 in.; side, ½ in.; back head, ½ in. Firebox—Thickness crown, ¾ in.; tube, ½ in.; side, ¾ in.; back, ¾ in.; throat, 11-16 in. Water space, front, 4 ins.; side, 3½ ins.; back, 3½ ins. Crank pin—Size main, 7½x6½ ins.; main side, 8x5 ins.; inter, 6x4 ins.; front, 5½x3¼ ins.; back, 5½x3¼ ins. Cylinder—Steam ports, H. P., 13½x19 ins.; exhaust ports, H. P., 3x19 ins. Tender—Weight empty, 55,600 lbs. Tender wheel base, 19 ft. 3 ins.; tender frame, 12 in. channels; tender truck arch bar type. Main valves, Richardson, balanced outside admission; travel 5½ ins.; steam lap, 1 in. exhaust O. Lead in full gear, 5-32 in.

**Collateral Security.**

In the free and easy days of railroading when no objections were raised to the engineer or fireman taking his best girl for a ride upon the engine, a lady and gentleman were permitted to ride in the cab of an engine on the Lehigh Valley Railroad. As the road was very crooked at the place where the incident happened the gentleman put his arm around the lady to keep her steady and explained that it was necessary to prevent her from being thrown off the seat by the lateral motion of the engine.

"Oh, I understand," remarked the girl, "there is lateral danger and you give me collateral security."

yond a certain rate, can only be done by an increase of steam pressure, which can only be obtained by increased expenditure of fuel, and such an expense increases in a tenfold ratio to the increased rate of speed obtained, to say nothing about the additional strain upon the boiler."

To overcome these imaginary deficiencies the locomotive with two driving wheels set up in the air above two other driving wheels that rested on the rail was built and put in service. There was considerable discussion on the invention, but there were very few engineers who believed that any advantage of steam or economy could be secured by the wheel arrangement adopted. Their judgment was vindicated by the results of practical service. The engine was tried on all kinds of trains, but proved inferior in every respect to the ordinary engines of the same capacity. The engine was examined as a curiosity in a variety of

\*From "Development of the Locomotive Engine," by Angus Sinclair.

roundhouses for a few years. There was always something needed to make its work satisfactory. After many changes the proper one was made when

method in the madness of the parties who got out the absurd Holman locomotive.

"They are advertising in Philadelphia

French had sufficient money in United States bonds to produce her an income of \$570 a year. Some idiotic friend advised her to invest in the Holman Locomotive Company's Stock, assuring her that she would more than double her income without risk. Our washerwoman never loses a chance to ask me when the Holman Locomotive Company will begin paying dividends.

THE AUSTRIAN DUPLEX.

There is no question that destructive blows are imparted to the rail from the unbalanced weights of the driving wheels. Inventors were early in the field to eliminate this blow by an opposing force, and, incidentally, to make a smoother working engine. This idea brought forth in Europe the Haswell locomotive, shown in Fig. 13. That engine, which was built in 1861, at Vienna, for the Austrian State Railway, excited much attention at the International Exhibition of 1862, where it was exhibited. The engine had two cylinders on each side, the power from the pistons being transmitted to crank pins diametrically opposite to each other, the expectation being that the momentum of each set of reciprocating parts would balance the other set.

The "Duplex," as the engine was called, was very powerful for that day, the cylinders being 10 $\frac{7}{8}$  ins. in diameter, with stroke of 24 $\frac{7}{8}$  ins. The driving wheels were 81 ins. in diameter. There were 15 sq. ft. of grate area and

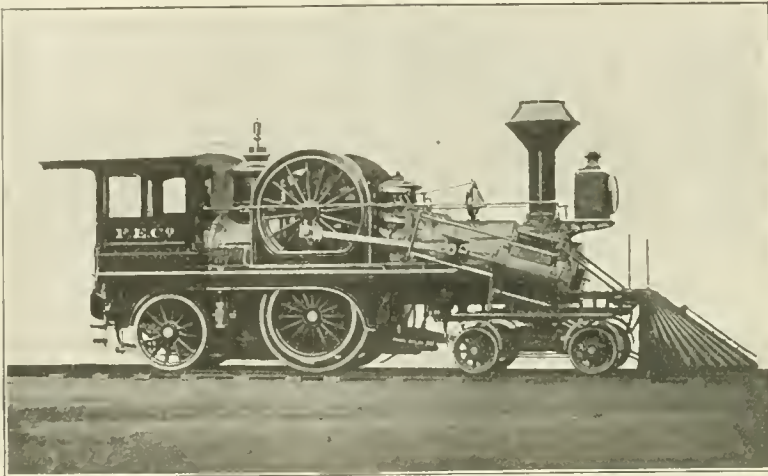

FIG. 11. FONTAINE LOCOMOTIVE.

it was converted into an ordinary eight wheel engine.

HOLMAN'S ABSURDITY.

It might have been supposed that the Fontaine experiment would have deterred others from trying such an expensive experiment again; but when an amateur gets seized with the malady for designing a locomotive of an entirely new pattern, he generally produces something startling.

In 1887 The Holman Locomotive Company had built in Philadelphia the locomotive illustrated in Fig. 12. I was immediately assailed by practical railroad men and others for my opinion of this, the latest monstrosity. I had not seen even a picture of the engine, but descriptions were freely written. My opinion, expressed in LOCOMOTIVE ENGINEERING, was: "It is a humbug. It is sound engineering to hold that every piece added to a machine, after it has reached the practical stage, is a source of weak-

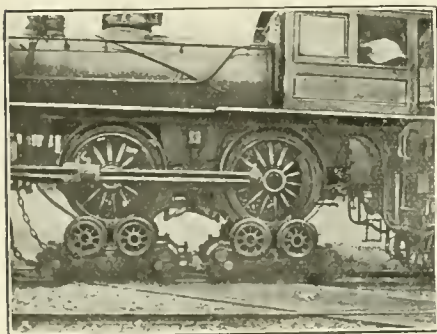

FIG. 12. HOLMAN LOCOMOTIVE.

ness. A triple set of wheels under a locomotive would be proposed only by one who is densely ignorant of mechanics."

Next notice in the same paper reads: "There appears to have been some

papers that a company has been formed to sell this kind of locomotive, the capital stock being \$10,000,000. They offer to sell the stock for \$25 a share, the par value being \$100. They make the claim that this sort of engine is destined to be the locomotive of the future."

Next notice, also in the same paper, reads: "The parties exploiting the Holman locomotive are advertising their stock in numerous newspapers, and claiming that the invention is certain to come rapidly into general use. The effect of that has been that numerous letters have come to us asking our opinion of the thing. We gave a general answer, the first paragraph of which reads:

"When we first heard of the Holman locomotive we supposed that it was the invention of some harmless crank who did not understand the elementary principles of mechanics, but we now believe that it has been, since its inception, an ostentatious machine designed to allure unwary capitalists into an investment which will be of the same real value as throwing gold coin over Niagara Falls."

The engine was run a few trips on a straight railroad in New Jersey, which was used merely as a stimulant to stock selling. Unfortunately many people with limited savings were allured, into investing their hard earned money in this swindle, and they might as well have given it to a highway robber.

One painful case that was pushed to my attention will illustrate the danger of taking stock in things recommended by friends. Mrs. Marion

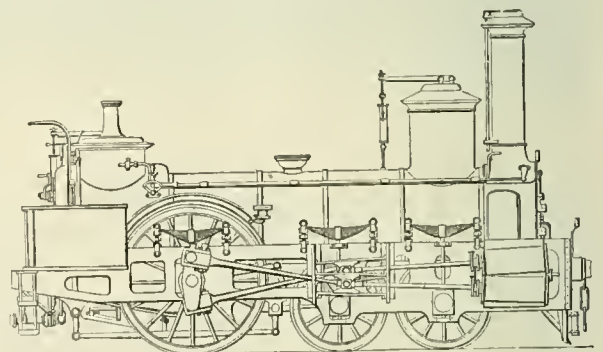

FIG. 13. "DUPLIX," AUSTRIA, 1861.

the heating surface was 1,344 sq. ft. The designer of this engine expected that it could be run with absolute steadiness, at excessively high speed, and the reports made of its performance in train service justified the belief concerning steadiness, but the advantage gained was not considered of sufficient importance to justify the repetition of the experiment.

The railway world had not begun talking about the so-called "hammer blow" in 1862, but the unsteadiness of many locomotives at high speed made itself manifest and various schemes were resorted to for the purpose of remedying the defect which was largely due to bad counterbalancing of

the driving wheels. The patent office records tell of many inventions being produced for making locomotives run steadier at high speed, but nothing of a permanent character has displaced counterbalance weights placed in the driving wheels.

During the iron rail period considerable ingenuity was devoted to inventions calculated to reduce the wear of

side, transmitting the power to crank pins diametrically opposite each other. One of the crank pins connected outside the driving wheel at the same position an ordinary crank pin would be located, and carried a double crank, the middle of which was supported in a bearing secured in an outside frame. That bearing was the driving fulcrum, a main rod working at each side of it.

tion in ordinary locomotives is entirely avoided." The soundness of that claim is open to dispute and the other claims advanced are even more open to argument.

The Shaw did not languish unknown through want of advertising. A gentleman named William E. Lockwood had the exploiting of the invention at heart, and few railroad officials of any

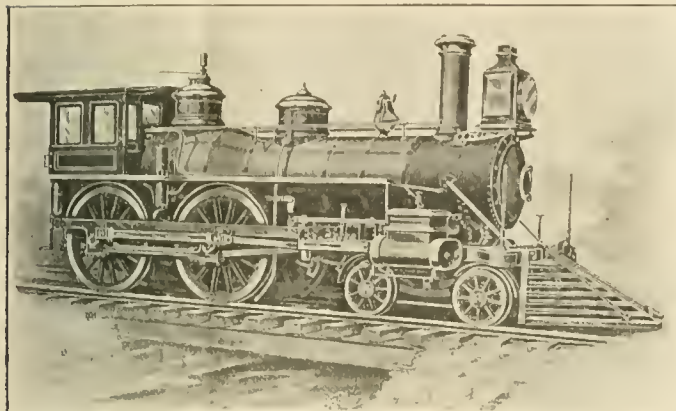

FIG. 14. SHAW FOUR-CYLINDER BALANCED LOCOMOTIVE.

rails, due to impact of the wheels. It was supposed for years that a low center of gravity saved the rails from destructive shocks. Years of experience demonstrated that a low center of gravity tends to lead the wheels into imparting destructive side shocks to the rails, but that was an article of knowledge that came to the railway engineering fraternity by very slow degrees.

THE SHAW FOUR-CYLINDER BALANCED ENGINE.

In 1881 there was built at the Hinkley Locomotive Works, Boston, a four-

The engine was equivalent to one with two cylinders 16 x 24 ins., and driving wheels 63 ins. in diameter. The weight in working order was 74,000 lbs., of which 25,600 lbs. was on the truck wheels. The boiler had 148 sq. ft. of grate area, and 981.75 sq. ft. of heating surface. The engine was well designed and built in first class manner. It was used to a considerable extent on train service in an experimental fashion, and worked quite satisfactorily.

The advantages claimed for the Shaw were: Perfect balancing, an increase in the area of wearing surfaces, and, by

consequence failed to learn how the "hammer blow" could be entirely prevented.

Some of the locomotives designed with special view to securing low center of gravity are curious. Zerah Colburn was a sensible railway man, with a good practical training as a mechanical engineer, yet in 1854 he fell into the blunder of designing the absurdity shown in Fig. 15. That engine had a double boiler, 43 ins. diameter, arranged so that the driving axle was located between them. It involved the use of two fire boxes, besides two sets of

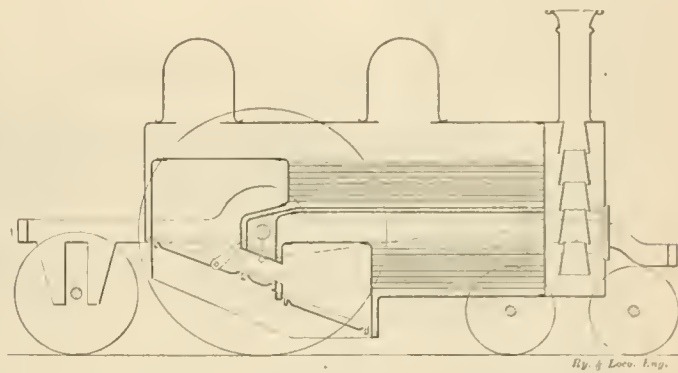

FIG. 15. COLBURN'S DESIGN OF LOCOMOTIVE DOUBLE BOILERS, WITH DRIVING AXLE BETWEEN.

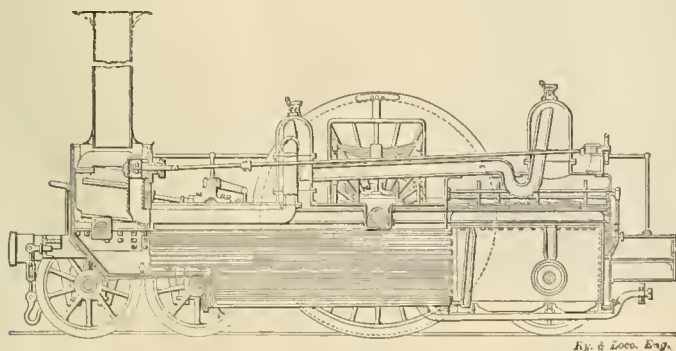

FIG. 16. TREVITHICK'S "CORNWALL," 1847.

cylinder balanced engine, called the H. F. Shaw, Fig. 14, which was industriously exploited as being entirely free from the pounding and oscillating action of two cylinder locomotives. The locomotive was substantially the same as Haswell's Duplex, except that the cylinders were arranged side by

dividing the work between four cylinders, reduction of wear and tear was accomplished, and, consequently, less risk of accident.

One claim read: "By utilizing all the force developed upon the piston directly upon the driving wheels to rotate them, the enormous loss through fric-

tubes. The best that can be said about it is that it was a very courageous design, but it came to nothing.

The attempt to make big boilers with low centers of gravity is illustrated in Fig. 16, which shows Trevithick's "Cornwall" built in 1847. It was a very awkward arrangement and required a

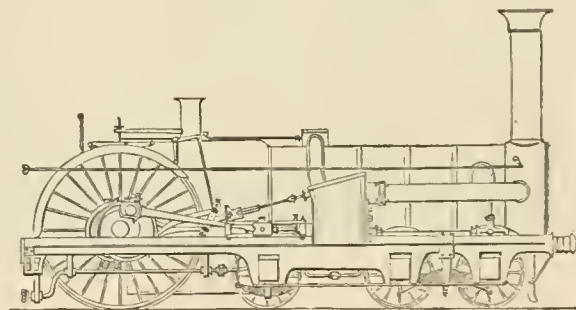

FIG. 17. CRAMPTON'S "LIVERPOOL."

recess being made at the top of the boiler for the driving axle to pass through. In service it was found that the engine did not run any steadier than those with a much higher center of gravity did. The very low center of gravity is a fallacy so far as steady running is concerned, because when the wheel in its revolutions receives

ins., and the outside,  $10\frac{1}{2}$  by 22 ins. The engine in service did not act as the patentees expected it would, and the type was never repeated.

#### Stop, Look, Listen.

The Long Island Railroad people have recently made some interesting experi-

ments with automobiles. The object of the tests was to determine whether or not the sound of the warning bells at level crossings could be heard by occupants of motor cars. The Long Island road is equipped with electric gongs at each grade crossing and these bells are automatically and continuously rung on the approach of a train. This is done by the short circuiting of a track current just as is the

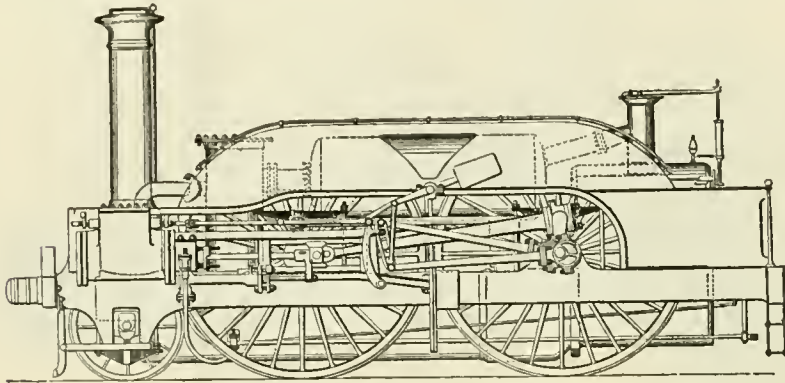

FIG. 18. MM. BLAVIER AND LARPENT'S ENGINE, "L'AIGLE," 1855.

sharp blows due to inequalities the shock is delivered to the side of the rail. When the center of gravity is high, like what it is in our Wootten engines, the blow strikes more on the top of the rail than on the side.

One of the principal oddities appears to be Crampton's "Liverpool," which was built in 1848, and is illustrated in Fig. 17. It has a huge single pair of driving wheels which was the Crampton peculiarity. The designer's idea of putting the driving wheels under the foot plate and the cylinders near the middle of the boiler was also the idea of getting a low center of gravity, and a comparatively big boiler. I had seen some experience with Crampton engines many years ago, and never saw anybody who had a good word to say about them, except those connected with the designing and building.

Fig. 18 shows interesting specimen illustrating the attempt to introduce enormously large driving wheels in Blavier & Larpent's engine "L'Aigle," built in France, in 1855. The engine was exhibited in the Paris Exposition of that year, and attracted a great deal of attention, but never did acceptable work in service. It had cylinders  $16\frac{1}{2}$  by 22 in. stroke, and driving wheels 2.85 metres, equivalent to 9 ft. 4 ins. diameter.

Another engine built and designed to obviate the disturbing force due to the action of reciprocating is illustrated in Fig. 19. This engine was patented by Stephenson and Howe, in 1846. The cross section looks like Webb's famous compound, but it was a small engine, and was intended to prevent the nosing action so well known with badly counterbalanced, outside connected engines. The middle cylinder was  $16\frac{3}{8}$  by 18

ins., and the outside,  $10\frac{1}{2}$  by 22 ins. The engine in service did not act as the patentees expected it would, and the type was never repeated.

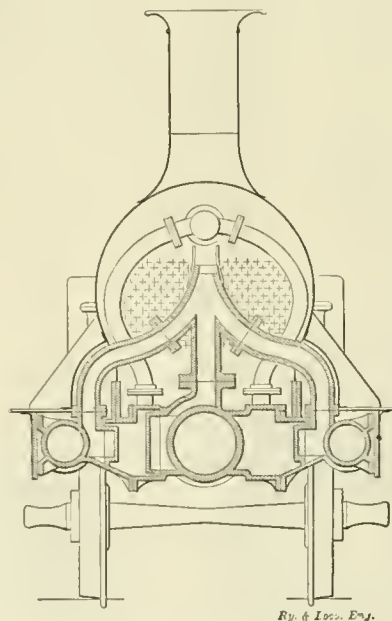

FIG. 19. STEPHENSON AND HOWE'S 3-CYLINDER ENGINE.

case with automatic block signals. The bells ring as long as the train is in the "block" or section of track before and up to the highway crossing. The tests were made at Oakdale, and it was found that those riding in the automobile could not hear the automatic, road-crossing bell, owing to the speed at which the machine was running and the consequent noise

#### Double Tracking on the U. P.

The undertaking known as the Lane cut-off between South Omaha and Lane, Neb., on the Union Pacific, although only 11 miles long, is the strong feature of the improvements now under way on that road. This line necessitates three million cubic yards of roadbed excavation, and calls for fills of from 300,000 to 1,400,000 cubic yards. The largest cut is a mile long with an extreme depth of 87 ft. The Lane cut-off saves nearly 9 miles over the old main line by way of South Omaha and Gilmore.

From Lane to Valley double tracking was completed last year. This fall will see the completion of another stretch of double track nearly 50 miles in length, from Valley to Benton. By the end of 1907 the Union Pacific will have a continuous double track in operation from Council Bluffs to Watson's Ranch near Kearney, a stretch of 194 miles. When all these improvements have been completed, together with others under way west of Ogden, it is believed that with their Omaha and Chicago connections the Union and Southern Pacific can further reduce the time from ocean to ocean.

#### Nature Works Quietly.

Silence marks the working of the greatest forces of life. None hears the sun draw up into the sky the countless tons of water that fall as rain. No man hears the groaning of the oak's fibres as it grows to its strength and height. Noise is usually an after-effect, and does not often accompany initial power. Sounding brass and tinkling cymbal are noisy, but not powerful. So the will reaches its decisions in silence, and it does not need much shouting to know when a man is in earnest. We need not become anxious when our sincerest work produces no great commotion nor has any startling effect; if we are really in earnest let us do what we can without unnecessary noise.

Had I a careful and pleasant companion that should show me my angry face in a glass, I should not at all take it ill; to behold man's self so unnaturally disguised and dishonored will conduce not a little to the impeachment of anger.—*Plutarch.*



# General Correspondence

## Tempering and Annealing Steel.

Editor:

There has been so much written on this subject by good, bad and indifferent mechanics that it would seem to be utterly exhausted, but I find questions and answers in most every mechanical journal I pick up on the best methods of tempering and annealing, especially the high speed steels used to a great extent these days. The writer don't claim to be an expert, but, being a practical steel worker for twenty years and reading and absorbing every scrap of information possible on the subject, and having the faculty of separating and making use of the good points gained by practice in that time, I think I can give some pointers that will be of value to any one who cares to profit by the advice of the undersigned.

The prevailing trouble with most steel workers is, they let their hands run away with their head to the extent that their work becomes mechanical, and in this age when different grades and classes of steel are used in most shops, the head should always be in the lead and be master of the situation. It stands to reason that it takes a different dip and different color for a high grade carbon steel than it does for a lower grade carbon. No shop that can avoid it will buy the higher priced steel when a lower priced steel will answer the same purpose. This is made the more possible by an intelligent heady tool dresser that knows the difference and gets results from both.

In the thorough annealing of carbon steels, lime, sifted ashes or charcoal dust give the best results, but any substance that is perfectly dry and will pack close will do nicely. The pieces should be heated evenly throughout to a bright red and buried deep. In water annealing I heat the piece to a low red and lay it aside until it will no longer scorch a pine stick, then cool it in ordinary water. Of course, the tempering of carbon steel is of a different character, and it takes good heating and an observance of the closest details and a thorough knowledge of the use and requirements of the tool, to get the best results. One source of failure with most smiths is, they will persist in dipping the tool too hot. A perfectly even heat and dipping at the right temperature for the required hardness comes along with practice and experience. I have seen quite a lot in different journals lately about the annealing of high speed steel, many

claiming they cannot get the steel soft enough to machine. Here's where the glutton for knowledge steps in and paves the way, for it is only the glutton that will experiment and persevere until he finds what suits the occasion best.

I have no trouble whatever in an-

the borings and put more borings on top until the steel is well covered; then fill the pot to the top with the burnt sand and leave it until cold. This anneals Novo and Blue Chip, perfectly so they can be machined as easily as carbon steel, and it does not affect the hardening qualities a particle. The



PIONEER RAILROAD WORK IN THE CONGO.  
(Stereograph Copyright 1907 by Underwood & Underwood, N. Y.)

nealing the high speed steels in the following manner, and I never heard a kick about pieces being too hard to machine, after I tried the following: I take an old ladle bucket or any iron receptacle large enough to hold the steel to be annealed. I fill this one-third full of well burnt, perfectly dry molding sand. I then put in half an inch of dry cast iron borings on the sand, heat the pieces of steel slowly to a bright red and lay them evenly on

borings should be fine as possible and free from oil. Charcoal dust and the burnt sand will both anneal to a certain extent, but not as thoroughly as with the fine borings added.

In hardening this class of steels I use both air and linseed oil. The heat should be as short as possible and white hot, and the cutting point dipped about one inch in the oil and when quenched sufficiently, transferred to the air blast to cool the body of the

tool. I have had high speed tools that lost their hardness and when this occurs, I harden them by dipping in boiling water, just so the cutting edge is immersed, and let the body of the tool cool off of itself.

Don't be in too much of a hurry on steel work, for it is only the man that pays the strictest attention to details and makes haste slowly that is thor-



MILLER'S DALE ON THE MIDLAND RAILWAY, ENGLAND.

oughly successful. If your work is pushing so it is necessary to have more than one piece in the fire, don't ram them all down next the blast, but put those you are not working with, on the side, so they will not overheat, and take them up in their turn.

Where several different grades and kinds of steel are used, mark them so you can tell at a glance what they are and what they require and put the marks down on a card and hang it up handy, so you can tell what they are, should you, perchance, get mixed up in your marks. Study your work and methods and ask questions of those you do work for. Work to please them, for a willingness to please sometimes covers a multitude of grouchiness and slovenliness in one's work. It is surprising how a little joke well told and a willingness to accommodate the man in a hurry will sometimes smooth the wrinkles of ill temper and make a tool do the work when otherwise he would throw it out the window and wish perhaps he had you there to follow the tool. T. Toot.

St. Louis, Mo.

Our life is not too easy, perhaps; taken altogether, it will bear any little smoothing we can give it.—*The Battle of Life.*

### In Mexico.

Editor:

The Vera Cruz and Pacific Railway after several years of poor management has been taken over by the Government and one of the most accomplished mechanical engineers in the South, Mr. Thomas Milan, was elected president. Soon after his installation in office the President of Mexico made a

tour of inspection over the road, running at a slow speed. The condition of the track was such that the president's train got derailed several times. The new president started reconstruction at once and conditions improved so rapidly that he soon earned the thanks of the Government. Now passenger trains make a speed of nearly 40 miles per hour. The engines are Baldwins, 8 wheel, 10 wheel, Mogul and Consolidation, and good ones. The machine and car shops are built of structural steel, all tools modern. There is no winter here. The shops are open all around ten feet above the ground to keep them cool, as this place is in the heart of the tropics. This is the rainy season and it pours nearly every night, with a hot sun during the day. Spanish is the language of the shop. The employes are all natives; some are very good mechanics. Coming here and being greeted in this foreign tongue made me feel like the tenderfoot coming West in the days when the cowboy reigned supreme. Just imagine walking up to the roundhouse register to see the work report on engine 101 and spell out the following: "Labor caldera arreglar purgadores ambos lado necesitar soprarlos pone bentanas enlado R. enlainer + ztas ambos lado," etc., etc. You would go back to your

school days. But we never thought then of studying the sweet and soft Castilian. It never occurred to us that we should learn the language of the country that was our next-door neighbor. I can now read an engineer's work report and get sense out of it (this does not include the American engineer, of whom we have several). I can ask the foreman if the "trabajo" work is completed on "Maquina" engine 100. His "Si, señor," sounds nice. North of here the road runs through a very picturesque country to Cordoba, skirting a range of mountains through sugar, rice and coffee plantations, pineapple and lemon farms and banana groves. To grow good coffee it is necessary to have good shade trees. Coffee is generally planted where trees have large spreading branches. Too much sun spoils the plant and the berry. A planter riding with me on the rear platform pointed out places exposed to the sun. The plants did not have that healthy color that they did where shaded. The Cordoba coffee has an international reputation and most of us have enjoyed its flavor. At Cordoba we connect with the Mexican railway, a splendid piece of property built with British capital and well equipped. Cordoba is an ancient and wealthy city of about 20,000 inhabitants, some wealthy Americans living there. A tribe of Indians are fruit farming close to the city. They are industrious and wealthy, retaining their custom of living apart from other people and never wearing shoes. Judging by the fantastic embroidery on their clothes the women are skilled with the needle, and wear costly jewelry. The market house is a wonder; nothing like it in the States. All kinds of tropical fruits and vegetables and all raised within



AN INGERSOLL BOY'S SNAPSHOT OF A CANADIAN FLYER.

sight of perpetual snow. Mount Orizaba never discards its mantle of white. Southward 150 miles we connect with the Tehuantepec railway. This road runs across the isthmus from ocean to ocean, similar to the Panama. The government is spending millions to make Salina Cruz a modern seaport.

The Tehuantepec Indians living along the isthmus are a thrifty, intelligent race. The women dress expensively and in their own fashion; they are very fond of American gold and many of them wear necklaces of \$20 gold pieces. They buy it when they can get it and will not have the other gold. They are a well-behaved race and all hard workers. This country is making rapid strides in its upward and onward march. The president is a wise and able ruler and has the confidence of the people. Like all southern countries, the rebel is abroad in the land, but he is handled with a grip of iron and his reign is of short duration. Railroading is yet in its infancy in this country. The wonders of its hidden treasures are not half explored. The unknown race wandering among its majestic cliffs are yet to bend their unbroken wills and obey the mandate of civilization. In the near future this line, forming a connection with the uncompleted Pan American Railway, will run solid trains through without change to Guatemala's capital city.

JAS. McDONOUGH,

Supt. M. P., Vera Cruz and Pacific Railway.

**Slide Valve Feed Valve.**

Editor:

I enclose to you cut of slide valve feed valve, showing quite an improvement in a small way. The feed valve that I am using is piped about four feet from the engineer's brake valve.

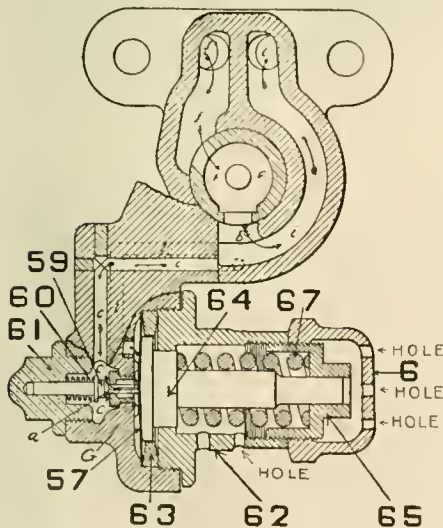

ALTERED SLIDE VALVE FEED VALVE.

When I first took charge of the engine I had quite a lot of trouble in keeping them in condition to do the required work. In taking the cap off of regulating nut No. 65 I invariably found it filled with water. I had three small holes about 1/8 in. bored in cap nut, also one in the bottom of the casing marked by check mark. After

drilling these holes I have had no further trouble in the eight months' time since these openings were made.

FRED NUNOOF.

*White Sulphur Springs, W. Va.*

**Old Mason Engine.**

Editor:

Seeing the Mallet Compound in the September issue of your interesting magazine, I enclose a photograph of one of the last bogies built by the

trip. This decision has to be made in a fraction of an instant; their responsibilities are very great, and the real or technical violation of some rule or special order is frequently involved. This article is written by one who served years on railroads, graduating from one position to another in the line of advancement, and now engaged in another occupation. The writer can perhaps review this subject in a way he could not were he a party interested



OLD MASON ENGINE FOR THE SOUTH ATLANTIC & OHIO.

Mason Machine Works. I do not happen to have all the particulars regarding her specifications, but she was an 18 x 24 ins. engine and her tank capacity was 3,000 gallons. She was standard gauge. She was built for the South Atlantic & Ohio Railroad, a road in Virginia and Tennessee. I imagine she may be in the scrap heap by this time.

HERBERT FISHER.

*Taunton, Mass.*

**Government of Railroad Employees.**

Editor:

There is hardly a phase of railroad service that receives more earnest thought and consumes more time of the operating and mechanical department officials than in investigating and passing on real or alleged disobedience of orders, or that endless chain of troubles ordinarily termed accidents, whereby the morale of the service has suffered, or damage to the company's property has followed. These remarks would apply only to those employees engaged in transportation service, as engineers, conductors, brakemen and firemen; other employees, by reason of their occupation, have but few rules to observe, competency in their duties being the measure of employment.

With the first named class their positions are peculiar. Working at all hours of the day and night, and often very long hours on duty, intrusted with property hundreds of thousands of dollars in value, and hundreds of lives depending on their vigilance, emergencies arising on an instant that call for prompt decision and action, be it right or wrong, many times every

in maintaining authority as an official or as an employee.

Few there are that covet the duty of being judge, jury and the executioner, as has been said of railroad officials who were perhaps a little severe in their rulings, and who must decide between man and company to reprove carelessness, shake out incompetency and rule justly; adjust the scales of justice that good service of the past may be recognized; or, in other words, that his decision will be salutary to the offender and convey instruction to the rest of the force. Disciplinary cases that call for investigation may be classed in a general way as social, as carelessness or forgetting, and as emergency. The first may include the drinking of liquors, the most common and severely dealt with. Second, the great annoying and distinctive class of cases caused by carelessness, forgetting, sleeping on duty, etc. Third, the emergency cases that constantly arise, the main issue being usually the question, Was proper care and judgment exercised?

The discipline, if any, administered if employee is found in fault may be either by reprimand, by the Brown system and its variations, suspension from duty for a period, or dismissal from the service.

There are complaints by some writers that there is a disposition on the part of railroad employees to resent investigation and imposition of one penalty for violation of orders or for accidents, and to bring into the case the protection of their brotherhoods. Be this as it may, there is seldom an effect without a cause, and

that the quality of the rank and file of train service men is not what it was formerly, I will speak briefly of the first and put it this way. As the railroads have grown large by building or consolidation, so have the officials by needed changes in staff and organization grown farther from the rank and file of employees, and where an official formerly had a hundred employees, he now has a thousand, yet his title and duties remain about the same; but he cannot be the same in personality to his men as formerly for obvious reasons, and the president of a railroad, to the same men, is a far-off, almost mythical personality, except when the order comes, "The president has ordered a reduction in forces." To the second charge I will say that it is my belief that in strong mentality and in physical requirements the men hired to-day are nowise inferior to the past, but there is a process of natural selection going on that has this effect, of a given number of men hired for the service, more will resign in a given period of the earlier part of their employment than formerly, a case of survival of the fittest. How shall employees, when amendable to discipline, be handled and feel that their treatment is fair; that is, whatever may be the ruling, it is the same as has been accorded others in like cases, though it may have occurred a thousand miles away? The writer has seen many decisions from the highest officers of railroads that stand like a ruling from the Supreme Court of the United States, but these related to pay or privilege. But now to the equally important, yes, more important, numerous and constantly arising class of investigations generally called accidents, and the ruling of, say, the superintendent may be very wide of what another would have done in a similar case, as each was a law to himself. Now, far be it from me that it should be inferred that the decisions are unfair or not humane. By no means, for there are no kinder hearts and sympathetic natures than those of our railway officials, most of whom came from the ranks. But there is a strong need, and there should be provided in a systematic form a list of rulings with proper notes that have been sustained by the highest authorities of the road that would provide a precedent and could be cited to employee or committee to show that no snap judgment was being taken and fairness only should rule, always taking into consideration previous good record, and not enlarging on previous errors, as it only tends to humiliate, and of all things this should be avoided.

What would be thought of a community or state that had no laws, yet

had courts and judges, and each judge decided according to his will, which might be mild from good nature or indifference, or severe by reason of a case of dyspepsia or family aggravations?

Would it not lift a burden of responsibility and care from all concerned, save no end of precious time to the busy official as he thinks over a mass of "statements" and wonders what he will do with the case? If he had a well digested file of rulings at hand for reference to aid him, for after all he wants to be fair and his opinions to conform to those of others, for he recognizes they are all of one big family. Therefore, written laws or rulings are very important, as employees now number thousands and a railroad is no longer a neighborhood or state affair, but almost national in scope, and its employees are quick to learn of all that occurs of interest to them, though it be very far away. If employees knew, as they would soon grow to know, what the consequences would be for dereliction of duty, would there not be a greater respect for standing rules and special orders?

Railroads have their several departments that control the complex functions of the corporations, but none that consider the great question of equity between corporation and employee (in this I do not refer to pay schedules), and to determine and arrange what is just and impartial, and I believe it is an important matter that has never been considered and, like Topsy "who never was born," this "has just drifted" on a tide of uncertainty.

There should be on all large roads a man holding the position of "referee," let us call him, who would compile from all sources available a code or book of rulings that would apply to the great majority of cases that ordinarily arise. This book made up on the loose-leaf system, with proper notes and references, and as the necessity for a change appeared old leaves can be removed and new ones substituted, and all properly indexed.

Thus out of a haphazard method, or lack of method, of handling one of the most important features of a railroad, there would be system and regularity. This would be applied to engineers, fuel and oil records and conductors' affairs, and reduce to a minimum the aggravated and pernicious practice of calling for an interminable lot of statements that are provoking to a point of rebellion. I state it explicitly, there is hardly a factor that has created a broader gulf between corporation and its men in transportation service than the reprehensible one—and it is only too common—of treating the written

statements of the men as more or less false, and that deception is intended. It is a base wrong and degrades all concerned, and has been fostered by a feeling that a big pile of papers concerning any matter had an appearance of thoroughness, when in reality it was to delay action from a feeling of "what shall I do about it?" and hence time and time again men are called upon to deny what they have already asserted and sometimes do to get rid of it, trusting the matter is now so old little or no action will be taken. This is an evil that cannot be too soon corrected. This is, or should be, a pertinent feature of reform of railway practice, as mentioned above. Expect the truth and you will receive it; look for falsehood and you will find it. By all means abolish the sweat-box statement system of reports. All statements should be brief as possible, and more than one should never be called for from each man, unless actually indispensable, and decision given as soon as possible and relieve suspense; but regularity and system should be the governing principle.

With the above thoughts may be rightly included those that bear on the loyalty of employees to-day as compared with the past, and what may be done that officers and men be of a closer sympathy than now. The officer is now a very busy man, works long hours and generally looks preoccupied, and the men know it, hence hesitate to approach, thus have grown apart. I suggest that once or twice a year on each division of a road there be called a union meeting of all employees in transportation service, not of one class, but all. These meetings to be arranged by the referee of the road. Let there be present the superintendent, master mechanic, train master and train despatcher. Then discuss no past grievances, but only future good, and carry them out by action. But the main thing is, get acquainted in a real way. The referee, who should be a well informed man, can give short talks on the service on other parts of the road, or on other roads dealing but little with the mechanical features of the air brake, coal or oil, or other train conditions, but having in mind the cultivation of friendship between man and man. The real handshake, open smile and cheerful greeting will put all on a level, and all will go from these meetings with lighter hearts and heads higher in the determination to do all possible for the good of the service and that theirs is not a "stake" road. The open meeting plan should be followed up consistently, and results will follow that will benefit public and corporation.

GEO. H. BROWN.

Dubuque, Iowa.

**Royal Bavarian 4-4-2.**

The engine shown in our illustration is one of the 4-4-2 type in use on the continent of Europe. It is one of what we sometimes call here a "wind-splitter," because the smoke box has a conical front and the front foot plate slopes upward toward the back and the front of the cab is shaped somewhat like the prow of a ship. Whether the engine goes along with less wind resistance or not we need not here argue, but one thing is certain, that the conical smoke box front causes the air to carry the smoke up and to prevent it from trailing down over the train when the engine is drifting. Several devices for doing this have been made use of on various railways; one of these was a false front to the smokestack, with louvers near the top,

and it is worked from a connection attached to the top of the Walschaerts expansion link. With this system oil is pumped when the engine is in motion; the lubrication supply ceases when the engine is not moving. The small horizontal cylinder, about half way up the smoke box and a little below the hand rail, is a device for actuating a variable exhaust nozzle. This is operated from the cab. At the back end of the side rod an upright rod is held, the upper end of which has a pin which works in the slot of a small arm projecting down from the box carried at the end of the V-shaped support hanging from the under side of the running board. There is a shaft running from this small box to another under the cab, and the whole arrangement makes a

has less "machinery" and fixings visible than we are accustomed to see on many of the continental engines.

**Blows, Not Pounds.**

One of the Kansas daily papers says that the engineer at the city waterworks has made a monster whistle for use at the pumping station. It is said to be the largest in the State of Kansas. The length is four feet and six inches and the diameter is eight and one-fourth inches. It weighs 125 pounds. Steam is used in sounding the blast, which is musical in tone, and can be heard on a calm day for a radius of twenty miles. This reminds us of a story told about Abraham Lincoln, who, when practising law, had a case where the counsel opposed to him was a windy orator and



FOUR-CYLINDER COMPOUND PASSENGER ENGINE FOR THE BAVARIAN ROYAL PALATINE RAILWAY.

A. Giesler, Chief Mechl. Engineer.

J. A. Maffei, Builder, Munich, Germany

which permitted air to rush into the outer casing, and so upward and over the stack in such a way that the smoke was carried along with the uprush of air. This was done on one railway in Scotland, as passengers had complained of smoke obscuring their view of the scenery. When the engine is working the smoke goes up as a matter of course.

This Bavarian wind-splitter, however, has cylinders 14 and 23 by 25 ins. (neglecting the small decimals), and is a compound engine with piston valves and Walschaerts motion. The driving wheels are 79 ins. in diameter and the steam pressure is equal to 15 atmospheres, or about 220 lbs. The calculated tractive power of this machine is about 11,684 lbs., as given by the builders.

The device, which looks like an air pump on the running board just in front of the reach rod, is an oil pump,

revolution counter, by which the speed of the engine is recorded on paper tape for inspection and retained for reference.

The boiler of this engine is a straight top one, about 63 ins. in diameter. The heating surface is in all 2,400 sq. ft., made up of 2,251.8, in the tubes of which there are 285, and 148.2 sq. ft. in the fire box. The grate area is 40.9 sq. ft. This gives a ratio of grate to heating surface of about 1 to 58. The weight of the engine in working order is about 163,700 lbs. The rigid wheel base is 7 ft. ½ in. The total wheel base of the engine 33 ft. 7 ins. The total wheel base, with the tender, is 55 ft. 2 ins. The tender has a water capacity of 4,400 gals., and about 6½ tons of coal. The weight of the tender in working order is about 104,000 lbs. The total weight of engine and tender is about 267,700 lbs. The engine is neatly finished throughout, and

Lincoln said that he was incapable of thinking when he opened his mouth. For the edification of the court Lincoln said his learned friend reminded him of a steamboat in the early days on the Mississippi which had a boiler four feet long and it was equipped with a proportionately large whistle seven and a half feet high, and it so happened that whenever the captain of the steamboat blew the whistle the engine stopped working.

Mr. E. R. Swan, heating and ventilating engineer, Cedar Rapids, Iowa, has put in operation an automatic car ventilator which requires no attention whatever from trainmen and can be readily applied to any car. The appliance has the quality of regulating the ventilation without fluctuation and, it is claimed, that a considerable saving in fuel will be effected by the use of the apparatus. The premature escape of hot air is prevented and the distribution of warm air is improved.

### A Floating Palace.

The prevailing tendency of railroad travel is to reduce the speed of trains, which is a result of the prevalent enmity to railroads displayed by so many legislatures. With ocean travel there has, however, been great advances in the speed of steamships, and there is no saying when the limit will be reached. The extraordinarily fast voyage from Liverpool to New York by the new steamship "Lusitania" of the Cunard Line has directed anew the world's attention to the power and speed capacity of marine engines, which have been greatly increased in the last ten years or more.

It seems to us that marine engineering has been making much more progress than locomotive engineering, although for years the locomotive was a

and both went through a protracted experimental stage. The locomotive emerged first as an established form, which was about 1830. Between that time and 1840 locomotives were running that did their work with from 3 to 4 pounds of fuel per horse power per hour. That degree of efficiency was not attained by ocean steamers until John Elder & Co., of Glasgow, Scotland, began about 1853 to introduce their line of improvements, which embraced high steam pressure, compound engines and better proportion of parts than had formerly prevailed.

But to return to the Lusitania. She arrived at New York from Queenstown on September 13, having made the run to Sandy Hook 5 days and 54 minutes, a steady speed of over 23 miles an hour.

250 sq. ft.; there are no less than a dozen steam ovens, half a dozen steam stockpots, half a dozen hot closets. Electricity has been largely employed, and works the large patent roasters, bread making, meat-slicing, potato peeling, triturating, cream-freezing, whisking and other like machines. Owing to the splendid system of ventilation there is a total absence of stuffiness. There are about twenty pantries and still-rooms, into which several novel features have been introduced. Those for the main saloon are in direct communication with the kitchen, thus ensuring everything being served hot and fresh. Such tiresome work as bread-cutting, sandwich making, dish-washing, etc., is done by electric machinery. Eggs are automatically boiled and timed. Coffee is made and milk heated



CUNARD S.S. "LUSITANIA," THE LARGEST PASSENGER SHIP AFLOAT.

more economical steam user than the marine engine. Most people familiar with engineering matters are aware that as late as 1838 a British authority on engineering questions made the prediction that a steamer could not carry sufficient coal to provide steam for the whole passage across the Atlantic. He figured on the engines using from 9 to 10 pounds of coal per horse power per hour. That power is now obtained for about 1.5 pound.

Steamers crossed the Atlantic under their own steam in 1838 and the service has never been interrupted, but has gone on steadily increasing and improving. At first the voyage from Bristol to New York lasted about 15 days. A few comparative figures will give a striking impression of the progress made since the first steamer crossed the Atlantic in 1838. The principal dimensions of that vessel—the Great Western, were: Length, 236 ft.; capacity, 1,340 tons, 250 horse power. Similar dimensions of the Lusitania, length 760 ft., capacity 38,000 tons, 68,000 horse power.

The building of locomotives and of steamboats began about the same time

The building of this great vessel is the result of rivalry between Germany and Britain, the Deutschland of the former country having held the best speed record for several years. This speed rivalry is likely to continue for several years, as several other British companies are having immensely large vessels built, speed being of course the desideratum, and Germany is not likely to accept defeat with Christian resignation.

This immense Cunarder, which is driven by turbine engines, has some extraordinary features. As already mentioned, her length is 760 feet, the longest vessel afloat. The width of beam is 88 ft., and her depth  $60\frac{1}{2}$  ft., 68,000 horse power, which will be maintained by boilers having 158,350 sq. ft. of heating surface and 4,048 sq. ft. of grate area.

The kitchens in the Lusitania quite eclipse anything afloat. The saloon kitchen and pantries extend right across the ship, and 126 ft. fore and aft. This department is equipped with every modern device for the preparation of food under the best conditions. The main range, probably the largest in the world, has a hot plate containing over

under the most cleanly conditions. Each pantry has a scullery in connection, where the dirty crockery is washed in electrically-driven machines. The third class passengers are well provided for, the kitchens being capable of providing food for 3,000 passengers or troops.

In order to test the effect of vanadium upon steel, a mild steel free from phosphorus, with a tensile strength of 30 tons per square inch and 17 per cent. of elongation, was melted in a graphite crucible. It thereupon became carbonized, and showed 61 tons tensile and 23 per cent. elongation. On adding 1 per cent. of vanadium the tensile was raised to 69 tons, with an elastic limit of 50 tons, and 7.3 per cent. elongation.

The comforts of mankind have been greatly improved under the era of the steam engine, but there are many still living under miserable conditions. Of the entire human race it is estimated that 500,000,000 live in houses, 700,000,000 in huts and caves, and 250,000,000 have virtually no shelter.

**Some Handy Appliances.**

Our little half-tone illustration shows some handy appliances in use in the Susquehanna, Pa., shops of the Erie Railroad, which is the headquarters of Mr. H. H. Harrington, the master mechanic of that division. Beginning at the left of the picture there is an eccentric blade bender. This is shown in detail in our engraving, Fig. 1. The

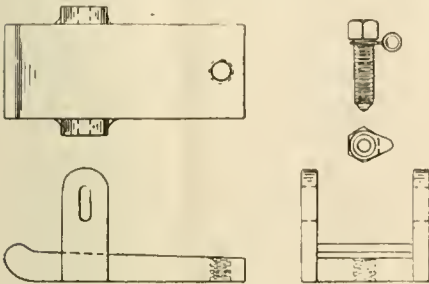

FIG. 1. ECCENTRIC ROD BENDER.

body of this tool is made of machine steel  $4\frac{1}{8}$  ins. wide and  $10\frac{1}{2}$  ins. long over all. It is 1 in. thick at the smaller end and tapers up to a bulb end like the front of a sleigh runner. There are two lugs, near the bulb end, which stand up on each side and are slotted for a flat key. The operation of bending an eccentric blade or rod consists in laying the rod down flat on the body of the device, slipping the key in place and inserting the set screw in the hole tapped out for it. As the set screw is screwed in, the blade or rod is forced to bear on one side on the bulb end and on the point of the set screw, and on the under side of the key on its other side. Forcing the set screw farther in, puts any amount of set or bend in the rod. The appliance is so made that it can be used when the rod is in place.

Turning again to our half-tone an eccentric rod twister may be seen. It is shown in detail in Fig. 2. This appliance is made in two pieces, and each one of them is simply a broad flat hook, united at the thin ends by a bolt with a beveled head and drawn together with a bevel nut. There is a little bracket on the under side of one of the twisters which holds the head of the bolt and prevents it dropping out while things are being adjusted. A small dowel close to the head prevents the bolt from turning, and the bevel head and nut allow the twisters to approach each other without distorting the bolt. The operation consists of putting the hook ends over the eccentric rod to be twisted; that is, the hook ends are slipped over the rod at the desired place and the nut tightened down. The twister hooks can be spread apart a short distance if desired, and the tightening of the nut makes each hook move in an opposite direction and so twist the rod. In this way the fork ends of the eccentric rods can be brought accurately in line

with the link, without taking the rod off the eccentric strap to do it.

On the table shown in our half-tone illustration, beginning at the right hand side is a solid die for making cylinder cocks. Next to it is an oil burner made from a globe valve or from a check valve. Next is the cylinder packing tool which was illustrated in our September issue, page 401, in a letter from Mr. Harrington. Farther to the left is a right angle drill, and beyond that is a drill press tool head.

**Railroad Superintendents.**

With reference to the word "Superintendent," in the early days of railways some companies had "collectors" and "intendents," not then known as station-masters. The officer in command of the various "intendents" on the line was the "superintendent." Each intendent was responsible for a district half-way to the next station on either side. About 1834 the intendent appears to have become

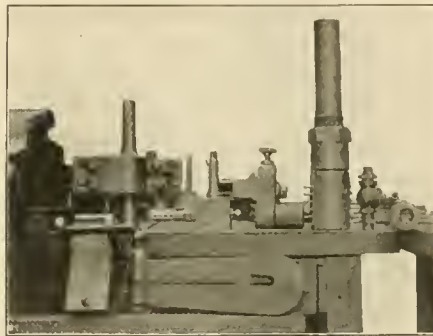

A BENCH FULL OF HANDY TOOLS.

known as "master of the station and collector," and his name was painted over the booking-office door. At the present time the Midland Company is following American practice, and has a running su-

perintendent, and also depot masters.—*Clement E. Stratton in English Mechanic and World of Science.*

**Double Tracking on the Pan Handle.**

The work of double tracking the Pittsburgh, Cincinnati, Chicago & St. Louis Railroad between Columbus and Bradford Junction is nearing completion, and when the entire stretch of eighty-three miles is ready, which will probably be this year, both freight and passenger service between Chicago, St. Louis and the East will be greatly improved. At

Woodstock the tracks were raised, streets carried beneath them and grade crossings eliminated. East of Urbana two important road crossings were eliminated, the streets being built under the tracks. Complete drainage systems and sewers were built through the cuts where the grade was lowered.

Incident to the double tracking was the building of entire new freight and passenger stations and yards at Covington. Active work on the double tracking from Urbana to St. Paris is still under way. The grade on Blue Hill, west of the Mad River, formerly a heavy pull, has been reduced from 1.1 to 0.7 per cent, and the total lift cut down fifty feet. A little more than one-third of the grading is now complete, and nearly three-quarters of the masonry. From St. Paris to Jordans, beside the second track work, an eastbound freight running track has been laid. This finishes the double tracking, except through Piqua, where the tracks are on a street.

**Rifled Pipe for Conveying Oil.**

A contract has been let by the Southern Pacific Company for the building of a rifled oil pipe line 256 miles long from the southern part of California to tidewater on San Francisco Bay. An interesting feature of the line is the rifled construction of the pipe. The rifling consists of indentations made in the interior of the pipe and following each other in a spiral line. A series of experiments in the conveyance of oil demonstrated the fact that after a small percentage of water had been added to the oil, and the necessary pressure applied, that the whole will develop a whirling motion, due to the spiral incline or screw thread form of the series of indentations, and that the water being the

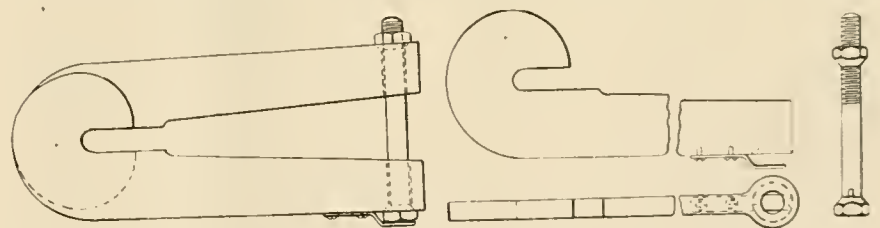

FIG. 2. ECCENTRIC ROD TWISTER.

heavier of the two, seeks the outside of the pipe, thereby enveloping the oil in a thin film or shell of water, which rotates as it passes along the pipe. This shell or film of water acts as a lubricant between oil and pipe, and reduces the friction and allows the core of oil to glide easily through the pipe.

Along the 256 miles of pipe there will be twenty-three pumping stations, the equipment of each station being in duplicate, so that in the event of a breakage of any part of pump, the other one may immediately be put into service.

# Railway and Locomotive Engineering

A Practical Journal of Railway Motive Power and Rolling Stock.

Published Monthly by

**ANGUS SINCLAIR CO.**

136 Liberty Street, New York.

Telephone, 984 Cortlandt.

Cable Address, "Loceng," N. Y.

Glasgow, "Locauto."

**Business Department:**

ANGUS SINCLAIR, President.

JAMES KENNEDY, Vice-President.

JAMES R. PATERSON, Sec'y and Treas.

**Editorial Department:**

ANGUS SINCLAIR, Editor.

GEO. S. HODGINS, } Associate Editors.

JAMES KENNEDY, }

**Advertising Department:**

Eastern Representative, S. I. CARPENTER, 170

Summer St., Boston, Mass.

**British Representative:**

THE LOCOMOTIVE PUBLISHING CO., Ltd.,

Amen Corner, Paternoster Row, London, E. C.

**Glasgow Representative:**

A. F. SINCLAIR, 15 Manor Road, Bellahouston,

Glasgow.

**SUBSCRIPTION PRICE.**

\$2.00 per year, \$1.00 for six months, postage paid in the United States, Canada and Mexico. For other parts of the world, \$2.50, or ten shillings. Single copies, 20 cents. Remit by Express Money Order, Draft, Post Office Order or Registered Letter.

Mailing address can be changed as often as necessary—always give old and new address, and if you subscribe in a club, state who got it up. Please give prompt notice when your paper fails to reach you properly.

Entered at the Post Office, New York, as Second-class mail matter.

Copyright by Angus Sinclair Co., 1907.

For Sale by Newsdealers Everywhere.

## Traveling Engineers' Convention.

The fifteenth annual convention of the Traveling Engineers' Association—which was held in Chicago in the beginning of September, lasting four days—was one of the best meetings in the history of the Association. It is hardly fair to make invidious comparisons, but we cannot help thinking that railroad companies derive more benefit from the work of the Traveling Engineers' Association than they do from any other. Probably the most expensive disorder in railroad operating is locomotive failures, which are legion and sometimes prostrate whole divisions for hours. Influences calculated to reduce the number of such failures ten per cent., have money value beyond calculation, besides promoting in a high degree the expedition and safety of train movements. We feel confident that the work of the Traveling Engineers' Association has done much more than this; and their exceptionally efficient methods of spreading information from road to road, from territory to territory, gives all the railroads of this continent the benefit of their mutual researches.

The writer has for years been an interested student of the causes that produce engine failures, but the papers and discussions at the last convention brought out a score of potential causes for engine failures that he had never thought of. The Traveling Engineers are to locomotives what doctors are to the human person. It has been the glory of medical associations to make public disorders that endanger life and how to detect or remedy such disorders. The saving of life and prevention of suffering due to the spread of knowledge by medical associations is beyond computation. The work of the Traveling Engineers' Association has an analogy to that done by medical associations, and deserves much more appreciation and recognition than it has hitherto received.

The Traveling Engineers' Association have always been noted for the close attention devoted to business during the conventions, also for the protracted sessions. This year's convention was no exception. Eight long reports or papers were read—not by abstract, but in extenso. Then each paper was discussed on the floor, when much additional information was given and not a few fallacies exploded. We know of no railroad organization where fallacies or creations of the imagination are so readily brought to their true value as among the Traveling Engineers.

An excellent paper which brought out a wonderful array of new facts in the discussion was one on "How to best locate the fault of an engine not steaming, without moving the draft appliances." Every motive power and train man is aware that when an engine is not steaming properly, the usual procedure is to experiment with the front end, causing much loss of time and often missing the real cause of trouble. Those of our readers interested in this important subject should not fail to study the paper and the discussion thereon published in another part of this paper.

Space does not permit us to go over the proceedings in detail, but we intend publishing all the papers and notes of the discussions, which give our readers the benefit of these most valuable papers and exchanges of views and beliefs. Unless the proceedings of this and similar organizations are published in such journals as RAILWAY AND LOCOMOTIVE ENGINEERING the real benefits of the work done are lost to those who ought to receive the benefit. The papers and discussions are published, it is true, in the annual report, but by the time it comes out nearly all interest has evaporated and very few of the reports are read in the finished form.

## Strength and Weakness of Rails.

The agitation on the steel rail question which was so active a few months ago appears to have died out and railroad companies are buying old forms and old weights. In connection with the rail question, a statement made by Mr. F. A. Delano, president of the Wabash Railroad, appears to have exerted a strong conservative interest. He took a stand in favor of comparatively light rails.

He held that "although the 100-pound rail is much stiffer than the 80-pound or the 60-pound rail, it is subjected to higher fibre stresses."

"The lighter rail," he said, "is more pliable than the heavier rail. Therefore it will conform more nearly to the inequalities of the track as a train passes. The heavier rail, being extremely stiff, refuses to conform to the inequalities; therefore, it frequently is required to become a bridge between two ties which are a long distance apart. The lighter rail, it may be seen readily, is called upon to perform bridge service only from tie to tie."

Mr. Delano does not inveigh against the steel rail manufacturers, but says the problem of steel rails is such a grave one that the manufacturers and the roads must get together and work out a solution. He has a suggestion. The segregation of impurities, he says, causes hard or brittle spots in the rail, and these impurities are concealed within the rail, where no inspector can discover them.

"A method of rolling which would divide the ingot," suggests Mr. Delano, "or possibly quarter it and bring this inside portion of the ingot to the surface, where it could receive the beneficial effects of forging, and where flaws or defects could be detected readily, it seems to me would be a step in the right direction. A rail must be hard enough and tough enough to withstand the rolling and abrading effect of the wheels and flanges. It must also act as a continuous girder to carry great loads moving at high speeds."

Mr. Delano has had an excellent engineering training and was for some time Superintendent of Motive Power of the Chicago, Burlington & Quincy. His views have always been held in the highest esteem by railroad mechanical men.

## Help Educate Enginemen.

At the last Traveling Engineers' Association meeting Mr. W. G. Wallace, one of the most sensible and farseeing members of the organization, said:

"I wish to call your attention to the address of the president of the Master Mechanics' Association and also to what they are doing on many of the



railroads to-day in regard to educating their apprentices. Is there a class of men employed on a railway whose work is more important than that of the engineman, and should we not, as Traveling Engineers, endeavor to use our energies in the line of education for those men to get good results? There is a shop problem, and you report to your Superintendent of Motive Power or whoever you report to, and are able to get the work done and the locomotive put in condition, and, as Mr. Deems said, then it is the man, and the opportunity awaits him.

"It is up to us, gentlemen, to educate these men, get them to think right, get them to fire right and pump right and run their engines right."

We heartily endorse these recommendations, but we go further. It is the duty of the Traveling Engineers to examine the engineers and firemen, but it does not rest with them to do much instructing, and their time is too much occupied by other duties. Railroad companies now nearly all require that firemen should pass an examination before being promoted, but no help whatever is given to prepare that man to acquire the knowledge he is supposed to possess. The railroad companies are moving to establish means of instruction for their apprentices, and from what we have learned nearly all important railroads will soon have apprentice schools in operation. That is a particularly wise move, but we think it ought not to be confined to the apprentices who work in shops. The apprentice on the locomotive—the fireman is destined to exercise as much influence on the earnings of a railroad as any unit of its working force, and it would be the part of wisdom to institute instruction facilities for firemen, for brakemen and for other individuals who have to pass an examination test of knowledge and efficiency.

#### Condition of Railroads.

An abstract of the Interstate Commerce Commission report ending June, 1906, makes interesting reading. It shows that in spite of adverse legislation railroads have continued to be prosperous.

There were 799,507,838 passengers carried, an increase of over 60,000,000, and 1,631,374,219 tons of freight carried, an increase of over 202,000,000. The average revenue the passenger a mile was 2.002 cents. The earnings a train mile increased, both for passenger and freight trains, and the average cost of running a train one mile increased. The ratio of operating expenses to earnings was over 66 per cent.

The report shows 10,616 persons killed and 97,706 injured. There were 1,521,355 persons on the payroll. One

passenger was killed for every 2,227,041 carried, while in 1905 one passenger was killed for every 1,375,856 carried. One person was injured for every 74,276 passengers carried, as against one injured in every 70,655 passengers carried in 1905. For each passenger killed, 70,126,686 passenger miles were accomplished, against only 44,320,576 passenger miles in 1905. One passenger was injured for every 2,338,859 passenger miles, against 2,276,002 miles in 1905.

The report shows an average of 684 employes to one hundred miles of line. There was an increase of 47 employes for each one hundred miles of line over 1905. Wages and salaries paid to employes aggregated \$900,801,653, but it is said that this amount is deficient by more than \$27,000,000 because of the loss of records in the San Francisco earthquake. There were 2,213 corporations for which mileage is included. In the year companies owning 4,054.46 miles of line were reorganized, merged or consolidated. The number of roads in the hands of receivers was thirty-four.

The number of locomotives and cars in service was 22,010,584, of which 1,827,780 were fitted with train brakes and 1,989,796 with automatic couplers. Only 1.54 per cent. of cars in the passenger service were without automatic couplers.

#### Adjusting the Exhaust Pipe.

The success that attended the efforts of George Stephenson in his early experiments in improving the locomotive was largely owing to the use of the exhaust steam as a means of creating an artificial draft on the fire and so making it possible to generate the volume of steam necessarily used in moving the pistons of a locomotive. Without this stimulation of combustion it would be impossible to maintain steam at a high pressure.

The relation of the exhaust pipe to the smokestack is very important and although their dimensions are necessarily the work of the constructor their proper adjustment is in the hands of the mechanics. Not only should the exhaust pipe point exactly to the centre of the smokestack, but it should be set perfectly plumb when the engine is leveled. In new work the exhaust pipe should first be placed in proper position and the smokestack adjusted so as to be exactly over the centre of the exhaust pipe. It will be noted that the volume of exhaust in locomotive running is not always alike and whether the draft on the fire is induced by a compact volume of steam filling the smokestack and producing a vacuum into which the air rushes like water following a pump plunger, or whether the steam is merely a jet occupying only a limited portion of the circle of the smokestack and so inducing draft largely by friction

of the particles of air, it is in either case of the utmost importance that the blast or jet should be in the exact centre. If the exhaust steam expands in its upward passage sufficient to fill the stack at its base a low pressure of exhaust steam will create a strong vacuum which will be equally felt in every part of the fire. On the other hand, if the exhaust steam strikes unevenly in the stack, leaving a portion of the stack untouched by the expanding jet of steam, the effect on the fire is of the most pernicious kind. The evil is increased if a portion of the exhaust jet strikes outside of the stack. This is often the case where low nozzles are used and also in the case of double nozzles.

Sometimes the form of the exhaust pipe is the cause of much trouble. Pipes that have a bend or set in them in order to bring the nozzles in line with the centre of the stack invariably injuriously affect the steaming qualities of the engine. It has been repeatedly demonstrated that a straight exhaust pipe will cause the jet to retain a straight direction, whereas pipes of a bending form, even if straight for some short distance at the nozzle, have the effect of causing the exhaust steam to flare or spread. These defects are sometimes so radical that the outer side of the smokestack will bear witness to the unevenness of the exhaust. The rapid condensation of the exhaust steam into water will show itself on one side of the stack, and when this is the case an uneven condition of the fire and consequent lack of good firing qualities may also be looked for.

Indeed, the proper adjustment of the exhaust pipe may be looked upon as of vital importance in locomotive construction, and in investigating the causes of defective steaming qualities it is well to begin by testing the alignment of the smokestack and exhaust pipe.

#### Acquiring Value by Reading.

The young fireman who wishes to learn his business and the ambitious apprentice boy in a machine shop who acquires a taste for reading the literature that deals with the work they are doing are to be envied by youths whose minds never stray beyond the literature of the ball game. The reading young man apprentice, foreman or brakeman, finds the literature of his business full of novelties that attract and amuse, while all the time he is imbibing instruction that may become valuable capital in after years. Writing on this subject of imperceptibly absorbing useful information by reading, Chordal says:

"The apprentice boy in a machine shop with a weakness for reading trade literature finds in the simplest everyday matter a subject of novelty to himself, and in the course of time his mind

becomes stocked with material gathered there item by item, each one as old as the hills to the world, but as fresh as the daisies to him.

"An apprentice boy sits on a block at noon reading a mechanical paper, and is thoroughly interested in an illustrated article on lining up engine guides. Some old gray-haired fellow looks over his shoulder, gets a general idea of the illustrations, and sneeringly remarks to the boy, 'Pshaw, that thing's a thousand years old. Is that what you fellows read about in those papers?' If the boy is smart he will reply: 'I am 14 years old, and this is the first I ever knew of this guide business. How old were you when you found it out?'

"When this same boy gets to be, say, fifty years old, he may possibly get disgusted with this kind of shop literature, and begin to think that the editor ought to be kicked for putting old things in the paper, thinking that they can be passed off for novelties. He may forget his own experience.

"Professional literature forms the annals of professional progress. The artisans' literature is not, and need not be consecutive in any of its arrangements. It presents a series of items which each individual arranges in his own mind for his own individual annals of progress.

"The real fact is that the literature of the artisan to be of any real value must contain repetitions on literary subjects, and there is a fine problem involved in finding out how often a repetition should occur."

We have among our readers the apprentice boy and the old workman, also the fireman and the old engineer. Behind them are the mass of other readers who will not suffer from having old stories told in new words. Men forget things so quickly that old memories will stand feeding with the knowledge that is new to the younger generation.

#### State Boiler Inspection.

The Public Service Commission of the State of New York are to be congratulated upon the prompt and effective steps they have taken to render the regulations for inspecting, testing and washing boilers of immediate application. In this work the Commission has been greatly aided by the State Inspector, Mr. G. P. Robinson, whose qualifications we have had an opportunity of knowing and whose fitness for the position is unquestioned either in education or experience.

The regulations provide that the chief mechanical officer of each railroad shall be held responsible for the strict enforcement of the rules in regard to the construction, inspection, repair and washing of boilers. The details cover

a pamphlet of sixteen pages and are divided into thirteen sections. Specification cards are furnished, wherein the results of each examination and test of boiler must be entered and legally attested to and placed on file in the office of the State Inspector. The bulk of the regulations are excellently adapted to a thorough boiler inspection, and while the burden of responsibility is placed upon the railway officials themselves, it is evident that there is an inclination to extend the work of the State Inspector's office so that it will eventually supervise every locomotive boiler in the same manner as is at present done in the care of the boilers of stationary engines.

The placing of the responsibility for the condition of boilers upon the chief officer of the mechanical department of railroads is but the legal expression of what has always been a moral obligation. The motive power officer and his subordinates on the great majority of our roads will hardly notice the change except as far as records are concerned. Careful, conscientious and systematic supervision is the object sought by the act and where this already exists the regulations of the Commission will not be found to be onerous.

A few of the regulations, however, seem to us to be somewhat arbitrary, and others are apparently unnecessary. Section IV, provides that "preceding the hydrostatic test the throttle pipe must be removed." We fail to see any sense in this, but much unnecessary labor of a difficult and delicate kind. In the event of breaking the joint of the throttle pipe and dry pipe, it is hardly to be expected that the joint could be made tight a second time without re-grinding. This would involve a removal of the dry pipe and T head, and in the event of a hydrostatic test being made with these appliances removed, it would be necessary to make another test after they had been replaced. To our thinking, as long as the throttle pipe remains tight nothing can happen to it. The throttle valve itself should be carefully refitted but the throttle pipe needs no removing any more than does a sectional sheet of the boiler.

The re-establishment of the glass water gauge is a step in the right direction. It should never have been removed from the locomotive boilers, and while it is not under all conditions to be absolutely depended upon, the glass gauge and three gauge cocks form a combination when properly located that leave little or nothing to be desired in the mechanism essential to showing the height of water in the boiler.

The provision rendering it imperative that all boilers be washed at least once

in thirty days is also a wise one, and the regulations cannot have other than a salutary effect on the running and management of locomotives with the result of increased safety and efficiency.

#### Book Notice.

Questions and Answers based upon the Standard Code of Train Rules for Single Track for use in the Examination of Trainmen. Sixth edition. Edited by G. E. Collingwood. Published by Train Dispatcher's Bulletin, Toledo, Ohio. 128 pages. Cloth. Price \$1.50. Prepaid.

The popular approval which has been accorded to Mr. Collingwood's work is well deserved. He has brought a lifetime of experience as well as a fine judgment in matters that are likely to remain controversial in the examination of trainmen. The book is intended more for the purpose of encouraging and aiding in a study of the rules in vogue generally than for the mere purpose of laying down personal opinions in certain conditions that may arise. The Standard Code is cheerfully held up as the guiding rule to all trainmen, but a perusal of Mr. Collingwood's able comments cannot fail to be of lasting value to all students who desire to attain to a thorough mastery of the many regulations affecting transportation on American railways. The book is finely printed and substantially bound, and in view of the important new additions to the work it should have an extensive circulation.

#### MASTER MECHANICS' ASSOCIATION PROCEEDINGS.

The report of the proceedings of the fortieth annual convention of the American Railway Master Mechanics' Association, which was held at Atlantic City in June last, has just been issued and forms a bulky volume of nearly 500 pages. The work more than maintains the high character of their annual publications. The reports of the various committees show that the work of the association is of no mere perfunctory kind. The debates on the reports bring out much that is of real value to railroad men, and the work altogether takes its proper place as the best annual reflex of the thought of our time on the questions that are uppermost in the minds of the leading mechanics interested in the mechanical appliances used on railways. The illustrations accompanying many of the reports enhance the value of the work, and the volume will undoubtedly aid in a marked manner the spirit that so intelligently guides the meetings of the Master Mechanics' Association in seeking a complete standardization of the multitudinous parts that go to make up the twentieth century locomotives. Copies can be had on application to this office. Price, \$1.50.

### Traveling Engineers' Convention.

The annual convention of the Traveling Engineers' Association was held at Chicago, September 3 to 6. President W. J. Hurley, of the New York Central, presided.

The practical business of the convention was opened by a report made by Mr. W. G. Wallace on the American Railway Master Mechanics' Association Convention, which he attended officially as representative of the Traveling Engineers' Association. He presented a brief summary of the proceedings.

#### HOW BEST TO LOCATE THE FAULT OF AN ENGINE NOT STEAMING WITHOUT MOVING THE DRAFT APPLIANCES.

In the absence of Mr. J. F. Emerson, chairman of the committee that pre-

pared this report, it was read by Mr. C. B. Conger.

that all engines when turned out of the shop be ridden by the traveling engineer, and he should pass on the draft on the fire, that is, as to whether the draft appliances are properly arranged so as to burn an even fire, and he should recommend any other changes that might be necessary in order to get the proper combustion and to insure the steaming of the engine. We think that under such conditions, if a traveling engineer would be furnished with the information relative to the amount of air passing to the fire through grates and ash-pan, he should be able to determine just how much draft would be necessary to be added from this source, or whether or not there would be too much. Also he should be furnished with the size of nozzle tip, in order that he might be better enabled to determine

the ordinary engineer will, of course, report to change draft sheet or pipe one way or the other, when this really could not be the trouble. On the other hand, the trouble would undoubtedly be due to the choked grates, flues, or improper distribution of draft from the ash-pan.

The following should also be noticed:

1. See that exhaust pipe is tight and not leaking.
2. See that steam pipes and T-head are not leaking.
3. See that front end door, frame, spark hopper and hand holes are tight and not drawing air.
4. See that exhaust jet strikes inside petticoat pipe or stack when engine is in action.
5. See that all nettings are clean and not clogged.



MEMBERS OF THE TRAVELING ENGINEERS' ASSOCIATION IN SESSION AT CHICAGO.

pared this report, it was read by Mr. C. B. Conger.

The report discussed draft appliances to some extent, although that was not intended. The salient parts of the report read:

Before interfering with the draft arrangements, after being applied according to blue-print or by standard, there should be a thorough examination made of the amount of air that passes to the fire through grates and ash-pan opening, and to be reasonably certain that not only the proper amount of air is obtained to properly ignite the gases, but also properly distributed. Next, be certain that the flues are clean, as when flues and grates are choked at different places in fire-box it has the appearance of an improper draft from front end, caused by the improperly arranged draft appliance.

We also suggest that the draft appliance when so arranged as to burn an even fire, should not be tampered with or allowed same to be, at the suggestion of the ordinary engineer. We recommend

the pull on the fire coming from that source. If it is not practicable for him to recommend changes, we think he should at least be required to give the shop or roundhouse forces such information as will enable them to determine just how much to change draft appliances or the necessity of making any other changes.

As a matter of fact, the way many engines are fired, even though they may be drafted right, they have the appearance of unevenly drafted engines, because the firemen bank the fire by firing at one place more than at others.

We also think it necessary for the road foreman to take into consideration the effect on the fire by different blows. With the different blows, the draft is not distributed alike on the fire. It is a practice with many men running engines to report engines not drafted right, when the fire has the appearance of burning more at one end than at the other; at times the middle of the fire-box seems to be the only place where the fire is burning, and

6. Observe action of exhaust on fire and see if fire is worked evenly over the entire grate surface.

7. See that the exhaust and stack are in line by plumbing, as an offset stack will very frequently spoil the draft and prevent steaming. At the same time the interior of the stack should be thoroughly examined to see that no fins, lumps, etc., are on the inside surface. Very frequently in cast iron stacks at the point where the pattern is parted there is an offset or groove left on the casting; this in all cases should be removed and the stack made perfectly smooth and free.

In arranging the draft rigging, we think it best to calculate mathematically what the distance of the draft sheet should be from the flues and from the bottom of the smoke-box. Also the exhaust pipe should be calculated mathematically as to the distance the tip of same should be from the base of stack or from the barrel of petticoat pipe or extended stack, as the case may be, so as to be reasonably certain that the exhaust strikes at the right

point to create a proper vacuum, which, in our opinion, should be of such a distance for the spread of the exhaust to not strike at all until it has passed the basis of the stack. We think this would insure a proper vacuum from this source.

We also suggest that the front end draft appliances be so arranged as to cause a natural draft, strong enough to draw the gases through the flues when engine is standing still. When this is accomplished, a larger opening through the exhaust can be had, which will produce a saving in coal and a better mileage by the engine in the way of running repairs.

In our opinion, the quickest method should be employed to make an engine steam in order to get it back to the shop without delay; but when the engine is in the shop, we think it is economy to locate the trouble, caused by improper drafting and too frequently by bad blows, and permanent repairs should be made here without bothering the nozzle tip. We also think that the opening should be calculated mathematically, and then every effort should be made to make the engine steam by properly regulating the draft, before reducing the size of nozzle tip.

J. F. EMERSON,

*Chairman.*

H. A. FLYNN,

W. A. BUCKBEE,

WM. DAZE,

J. W. FOGG,

*Committee.*

Mr. Fogg made a supplementary report in which he discussed three causes for engines steaming poorly, viz.:

1. The quality of fuel.
2. The amount of air or draft.
3. The kind of water.

He attributed bad steaming in many cases to the water being heavily charged with solid matter.

This report led to a very protracted discussion.

Mr. W. H. Corbett, Michigan Central, found other causes for engines not steaming. Among them were cylinder packing broken or blowing, valves leaking badly. The gasket at the base of the stack broken or loose, air passing between the arch and the base of the stack, a hole in the side of the petticoat pipe, netting too fine, he regarded as obstacles to free steaming. Other causes were engineer carrying the water too high and getting wet steam, which has a tendency to clog the netting; a blower pipe cut and leaking and interfering with the vacuum in the smoke box.

Mr. Frank P. Roesch, Southern Railway, thought the discussion should be confined to causes for poor steaming outside the draft appliances, but he favored discussing defects of fire box, grates and ash pan. He did not believe that too much air could be admitted through the ash pan except when burning lignite coal. Thought the openings of the ash pan

should be so distributed to give uniform draft over the grates. The question of grates enters largely into free steaming, but is governed by the quality of the coal. He combated the correctness of some statements made by Mr. Fogg on the heat retarding extent of scale.

Mr. J. A. Talty, D. L. & W., commended the report, and corroborated Mr. Corbett's statement relative to leaks between smoke stack and saddle. Favored stacks being bolted securely down, favored means to prevent steam failure from the cylinder casting getting a hole in it. Had known of fifteen such cases within the year. Another case they had found was single nozzle tip getting stopped up at one side.

Mr. D. V. Musgrove, C. of G., contended that an opening in the front end above the height of the exhaust stand or draft sheet would not prevent an engine from steaming. Opposed the idea of taking an engine back to the shop when she can be taken on. Believed designing the air openings to ash pan belonged to the mechanical engineer. He had known of trouble from the openings of the ash pan getting clogged up when the ash pan was blown out. Bad coal was a fruitful source of poor steaming engines.

Mr. Talty defended the position he took in regard to the injurious effect from the admission of air on any part of the smoke box.

Mr. Angus Sinclair remarked that there are a great many anomalies in connection with draft appliances. Several railroads in Europe use open holes in the bottom of their smoke boxes, and the practice had been followed by several railroads, notably the Fall Brook. Another thing we hold that the exhaust pipe should always be central with the stack, but the Mason bogies would have it so set that it would strike the side of the smoke box when the engine was rounding a curve, and the engines steamed well.

Disputed the correctness of the theory advanced that too much air could not be admitted through the ash pan. The rush of air was sometimes so intense that a heavy fire must be burned to prevent the air from depressing the temperature of the fire box.

Mr. J. D. Benjamin, C. & N. W., thought that where examination found draft appliances all right that the engineer and fire man ought then to receive attention. Has found engines come in reported not steaming, then when another crew was put on the complaint ceased. There is too great a tendency to reduce the nozzle if it is not checked. Knew of a case where an engine came in with a brake wheel in the stack and a three-eighth pipe in the nozzle. Held that 75 per cent. of the trouble from engines not steaming lay with the engineer and fireman.

Mr. Roesch corroborated what Mr. Sin-

clair said about the Mason bogie engines, and also about the openings on the front end of some engines. Enjoyed personal experience with Mason bogie engines. The boiler rested on a center casting, so in curving the boiler kept straight on while the cylinders curved. Sometimes the springs that supported a plate in bottom of smoke box would break and allow the plate to fall down, leaving a hole as large as a fire box door, but that did not affect the steaming.

Mr. Conger mentioned a case where one injector was so located that the engineer had to crawl round the reverse lever to start it. His habit was to keep it on as long as possible and not to start it again until he had to. Under that treatment the engine steamed badly, but when, on complaint, the injector was put in a convenient position there was no more lack of steam.

Mr. De Haven directed attention to two sets of engines, one set with leak in smoke box that would reduce the draft, but they steamed satisfactorily.

Mr. A. M. Bickel, L. S. & M. S., agreed with Mr. Benjamin about engineers and firemen causing engine failures. He mentioned a case of a badly steaming engine that baffled the traveling engineers and master mechanics. A bright traveling fireman located the trouble in loose rivets at the top front of the left side sheet.

Mr. Benjamin mentioned a case where his engine lost the cinder hopper valve on the road, and it did not affect the steaming of the engine to a great extent.

Mr. Musgrove told of two engines that became poor steamers and they had intense difficulty in locating the trouble. Finally the defect was located in leaks of the joint where the smoke box connects to the boiler. In reply to a question from Mr. Talty, Mr. Musgrove took the stand that air passing through the connection sheets prevented the engine from steaming.

Mr. Ferguson said that he thought front end leaks prevented engines from steaming freely. On the Norfolk & Western they had great trouble with leaky flues causing engine failures. They began using soda ash in the boilers, and provided blowing out cocks, which had to be used systematically, which cured the leaking of flues.

Mr. F. C. Thayer, Southern Railroad, had improved the steaming of engines by adjusting the exhaust pipe centrally. With the double exhaust pipes they locate the pipes so that the exhausts cross. Held that front end ought to be kept air tight.

Held that special attention should be given to keeping valves square. Valves out of square frequently protracts the cut off and thereby wastes fuel. Engineers ought to be urged to use the injector as evenly as possible, as it improves the steaming qualities of engines.

*(Continued on page 464.)*

# Correspondence School

## Electrical Induction.

As long ago as 1831 Michael Faraday made the discovery of electro-magnetic induction. In other words he found how to produce an electric current by the motion of a magnet or of a coil of wire, and this discovery is the basis of all the machines which are used at the present time to light our streets and our homes and to move the trolley cars along public highways.

Faraday's discovery, though it was probably one of the most important ever made, consisted in essence in the performing of what would seem to us now, a very simple experiment. It was something like this: Take an ordinary coil of wire in which the various "turns" do not touch one another and join the ends so as to make what electricians call a closed circuit. Now if an ordinary bar magnet be quickly inserted into the coil without touching the wire a momentary current of electricity will flow in the coil. If the magnet be rapidly withdrawn a momentary current will flow through the coil but in the reverse direction.

If the magnet be left standing in the centre surrounded by the coils no current will flow. It is at the moment of introduction and withdrawal of the magnet that the current flow takes place. Such a current is called an induced electrical current and the phenomena is called induction. This kind of current is sometimes called Faradaic electricity after the great discoverer. The same effect is produced if the coil is moved over the magnet and quickly withdrawn. The quicker the motion the stronger the currents. The flow first in one direction and then in another is what constitutes an alternating current.

The magnet does not become weaker by being frequently used, for the production of electrical energy is due to the mechanical motion of the magnet into and out of the coil. If the coil does not form a closed circuit no current will flow. No one knows with certainty what electricity is, the motion of a magnet or coil of wire within the sphere of influence of the other, produces current.

A current of electricity may be induced in a closed circuit if the magnet is moved near it, or if the closed circuit or a part of it be moved near the magnet or across the magnetic field in any way, and it is the energy of the motion of either magnet or wire

which is the real cause of the flow of the current.

A dynamo is nothing more than a machine in which two or more magnets are usually held stationary and a series of closed wire circuits are made to revolve between them so as to cut their magnetic fields. At each revolution currents are induced in the revolving coils, or the armature as the collection of coils is called. As the coil approaches the magnet a momentary current flows, and as it recedes a reverse current flows in the wire. These alternate reverse currents are collected and made to flow in the same direction in the line wire of the circuit by a contri-

from the steam engine at the power house, into electrical energy, is a transference of the energy which resided in the coal burnt under the boilers and in the electrical form it is easily handled and transported, and it can be made to re-appear in the form of light, as in an arc or an incandescent lamp, or it may turn the wheels of a trolley car or operate machinery. In these forms it is again mechanical motion. Each transformation is necessarily attended with a certain amount of loss. The total amount of energy derived from the coal, is, however, accurately accounted for in the forms of friction, work, heat, current, etc. Energy itself is



FORNEY ENGINES ON THE NEW YORK ELEVATED RAILROAD BEFORE THE ELECTRIC POWER WAS USED.

vance called a commutator, which revolves with the coil.

The magnets used in a dynamo may be either permanent steel magnets or they may be electro-magnets, that is, they may be soft iron cores rendered magnetic by the flow of a current of electricity in a wire coiled about them, and this coil may receive its current from a separate machine called an "exciter," or the magnetic state may be produced by various windings of the main circuit wire about the iron core, these machines are called self-exciting machines and are contrivances for converting mechanical motion or the moving energy of the armature into electrical energy. The name dynamo applied to these electric generators is derived from the Greek word *dynamis*, power, and this form of electricity is frequently spoken of as dynamic electricity. The word dynamite comes from the same Greek root.

The transformation of energy derived

indestructible. As far as nature is concerned the energy was originally derived from the sun and ultimately disappears as heat.

## Elements of Physical Science.

### VI.—MOTIVE POWER.

There are a number of powers which produce motion, the best known of which are gravity, the elastic force of springs, the muscular strength of man and of animals, the force of wind, water, steam and electricity.

The power of gravity is applied by attaching weights to machinery, the downward tendency of the weights keeping the machinery in motion, as in some kinds of clocks. When there is not room for weights, a coiled spring of elastic substance produces motion by a constant effort to unbend itself.

Man can produce a certain degree of motion with his own strength, but the result is not great. Much assistance

is derived from the strength of animals, one horse being reckoned equal to five men. Still more powerful forces are found in wind and water. The irregularity of wind power is a serious drawback to its use. Water power is also subject to variations, but there is less difficulty in water power than from the variations of the wind.

The greatest of all powers used by man is steam, the vapor generated by submitting water to a high degree of heat. There is no limit to steam power, its use being limited to the degree of resistance of the vessel in which it is enclosed. Its application to machinery marked an epoch in the world's history. Its properties and applications will be considered in the chapter on elastic fluids. Of the force of electricity we shall also treat in its proper place, but it may be stated that this great and mysterious force is developed by friction, by chemical action, by magnetism, and by heat.

#### RESISTANCE.

The most common form of resistance is that of a weight to be moved with reference to work of any kind. An established unit of work is raising one pound through the space of one foot. From this basis any degree of resistance can be readily calculated. A horsepower consists in the raising of 33,000 lbs. one ft. in a minute. Friction adds to the resistance of all bodies being moved, as when a weight is dragged over the ground. In machinery the rubbing of the different parts together is always an important factor, adding to the degree of resistance. In this latter connection it may be stated that the friction of a body is much greater when it commences moving than after it has been moving for a time. Friction is lessened by smoothing and polishing the surfaces, and by putting grease or other lubricants between the surfaces. Finely powdered plumbago and graphite are among the best articles used for this purpose.

It should be noted that friction has its advantages. Without friction the driving wheels of a locomotive would turn on the rails without moving it forward, and without friction man could not walk. When friction is lessened, as on ice, we walk with difficulty.

#### MACHINES.

All machines are instruments used to aid the power in overcoming resistance. Tools such as chisels, saws and hammers are simple machines, and, like engines and other machines of great power, they merely aid the power in its action. They do not create power. All machines remain at rest until acted on by some motive power, and whatever a machine gains in amount of work it loses in time, and

what it gains in time it loses in amount of work. This can be readily seen in the use of the crowbar, by which weights may be slowly moved, although much heavier than a man is able to lift.

Machinery not only enables us to use our power more conveniently, but it enables us to use other motive powers besides our own strength. The limit of the power of machinery is the strength of the materials of which it is made. Machines that will work well in small models sometimes fail when made full size, because when the resistance is increased and their own weight is added, the material will not stand the strain.

#### STRENGTH OF MATERIALS.

The determining of how great a strain certain materials will bear, and

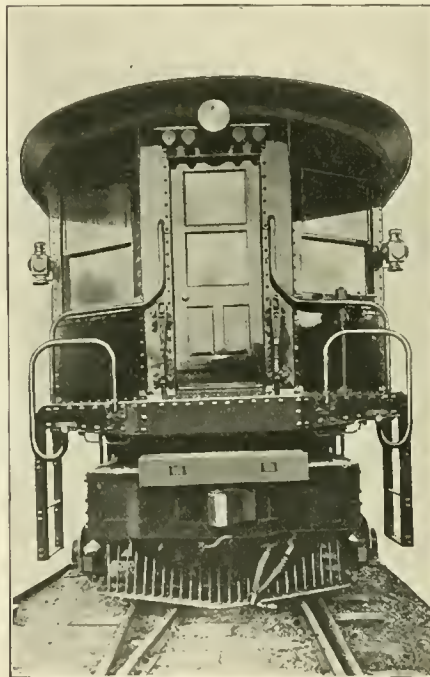

ELECTRIC LOCOMOTIVE ON THE PENNSYLVANIA RAILROAD.

how they may be joined together to the best advantage, is of the utmost importance in practical mechanics. The relative strength of materials has already been briefly treated of, and it may be added that rods and beams of the same materials and uniform size resist breakage in the direction of their length with degrees of strength that vary in a ratio to the areas of their ends. If two rods of equal length and thickness are used in sustaining a weight, it will be found that by increasing the area of the end of one rod it will sustain an increased weight. The strength of a horizontal beam supported at each end diminishes as the square of its length increases. It is most easily broken in the center, and if

a beam of uniform strength is required, it should taper from the middle towards the ends.

It should be noted that a given quantity of material has more strength when disposed in the form of a hollow cylinder than in any other form that can be given it. Nature teaches us fine lessons in the construction of bones and the tubes of feathers, where the elements of strength and lightness are combined in an eminent degree.

#### Eminent Engineers.

##### 1.—HERO OF ALEXANDRIA.

Hero of Alexandria was the son of a Greek nobleman who had settled in Egypt during the Greek occupancy of that country. Among the notable institutions in Alexandria was a school of philosophy which was resorted to by the learned and ingenious of many countries. Under the splendid dominion of the Grecian Kings, the arts and sciences reached a high degree of perfection. Philadelphus, one of the Ptolemies, and his successors encouraged the study of Mechanics, and opened the path to personal honor and emolument to those who excelled in scientific research or in the accumulation of exact knowledge.

In Mechanics, Hero was the most inventive engineer of ancient times. Even in our age of wonderful invention much of his work remains as he left it. The fountain for raising water by the compression of air was of his contriving, as also the method of creating a vacuum by sucking the air from a vessel. He constructed the first force pump for quenching fires and the fire engines of to-day throw jets of water exactly as the engines of Hero did. He invented three separate and distinct kinds of steam engines. The first raised water by the elasticity of steam. A second raised weights by movable pistons and platforms. The third produced a rotary motion by the reaction of steam striking the atmosphere.

It is common to consider the bulk of Hero's inventions as mere mechanical toys, taking their place in the amusements of the ancients, something in the same manner that firework devices do in our own day, but in his own time and among the rude devices of his predecessors his work stands out with surpassing merit. The steam engine, or some other colossal force, had not become a physical necessity. If it had, Hero and his engine would have risen to the occasion. As it was he used it in opening the doors of temples, in producing a hissing sound in the mouths of dragons, in bringing tears from the eyes of images, and other trifling performances which seem very idle to us, but were doubtless looked upon as wonderful in the centuries that preceded the Christian era.

His most popular engine seemed to have taken the form of a revolving globe into which steam was admitted at one of the bearings or trunnions upon which the globe rested. Short pipes were inserted in the globe at an angle so that the steam rushing out at the openings caused the globe to revolve. Another contrivance was a wheel furnished with blades or buckets into which a jet of steam was caused to rush which caused the wheel to revolve. The steam turbine, which is the boast of marine engineering of the present century, is a mere adaptation of Hero's masterly invention.

## Questions Answered

### RECHARGES ON GRADES.

(87) F. S. Basalt, Colo., writes: On a hill of 8 miles in length of steady or continuous 3 per cent. grade, 18 loads, consisting of cars from 25 tons to 50 tons capacity, with all kinds of brands on the cars such as we handle on these Western roads loaded with through business, all cars equipped with Westinghouse and New York brakes, speed of 20 miles per hour, how many recharges should be made on this train in this distance with 80 lbs. train line pressure, all retainers up and no hand brakes?—A. To handle a train safely while descending a 3 per cent. grade care should be taken not to let the speed get high, and the applications and releases should be made frequently so as to hold the speed down and to maintain the maximum brake pipe pressure. The number of applications, releases and recharges necessary to accomplish this will vary with the condition of the brakes, pressure retainers and the tonnage in the train. Under the average condition of brakes, pressure retainer and tonnage, from 6 to 8 recharges would be sufficient, if an average speed of 20 miles per hour is maintained during the descent.

### INDEPENDENT VALVE IN RELEASE POSITION.

(88) F. C. M., Little Falls, N. Y., writes: I wish to ask a question in regard to the independent brake valve. Air brake instruction pamphlet 5,025 states that in order to prevent leaving the handle in release position, and thereby interfere with satisfactory application of the locomotive brakes with the automatic brake valve, return spring 9 automatically returns handle 15 to running position as soon as the engineer lets go of it. Would it be possible to operate the independent brakes with the automatic brake valve if spring 9 of the independent brake valve failed to move the handle from release to running position after the engineer lets go of it?—A. If the handle of the independent brake valve is in release

position the locomotive brakes will not apply when the automatic brake valve is used. When using the independent brake valve to release locomotive brakes the engineer should not take his hand off the handle until it is in running position, regardless of whether spring 9 works or not.

### EFFICIENCY OF RODS AND GEAR.

(89) J. L. M., Oshkosh, Wis., asks: What is the efficiency of the side and connecting rods drive of the steam locomotive? (2) What is the efficiency of each, the side rod and the gear drive? I understand the electric is about 85 per cent. and I wish to know the comparative practical value of the side rod. I am particularly interested in the information with respect to the drive from one wheel to the other where the side rods are set at quarters.—A. This differs with the design of the engine, and can only be worked out by making a diagram of the strain produced in the rod and by the parallelogram of forces resolving the strain into two parts: (1st) useful turning effort; (2nd) radial pressure on the crank. If this is done for a number of points in the same revolution it can be estimated by taking the ordinates of part (1) and comparing them with the actual pressure in the cylinder at each position. The side rod has no theoretical value, it only transmits a portion of what would otherwise be applied to the main driver. The problem is rather complicated for the average man.

### DOUBLE HEADING WITH ET BRAKE.

(90) G. E. C., Cardenas, Mex., writes: We are handling ET equipment entirely on this division of the Mexican Central Railway. In one case we were double heading. I had my automatic brake valve lapped and cut-out cock underneath closed. I never had any trouble whatever with the air on this engine before, or with any of its appliances, but in this case of double heading it could not be released from the head engine, and at different times it would reapply after release. We had to cut it out entirely in order to get into division terminal. Have had no trouble with it since. Where would I look for the trouble?—A. If the brakes were held applied for quite a while, it is likely that main reservoir leakage into the pressure and application chambers, through the maintaining port in the seat of the equalizing slide valves, raised the pressure therein higher than brake pipe standard pressure, and hence the head man could not release your brakes due to inability to force the equalizing piston against the high pressure chamber pressure. Again it may be that when the head engineer released the brakes he overcharged the pressure chamber on your engine, and the brakes reapplied in consequence

just as they do when an auxiliary reservoir near the head end of the train is overcharged, or when it is charged up higher than those at the rear, and the brake valve handle is returned to running position too soon. Whether it was a case of main reservoir leakage into the pressure chamber or one of overcharging of the latter it could be determined by carefully watching the air gauges. We do not understand the necessity for cutting the brake out in order to reach the terminal, since if the handle of the independent brake valve is moved to release position the locomotive brakes will release regardless of method of manipulation by the head man, or of the amount of pressure in the pressure chamber and in the brake pipe.

2. Where can I get a good book on this ET equipment?—A. From our book department. Blackall's Up-to-Date Air Brake Catechism covers the subject thoroughly.

### DESIGNING LOCOMOTIVE RODS.

(91) H. O. M., at Lincoln, Neb., writes: Suppose we were designing a locomotive and know the type, pressure, size of cylinder, size of drivers, kind of service, etc., and wish to design a set of rods having a factor say 5, kindly give the method of calculating the strength of both side and main rods considering both are fluted.—A. This is a complicated formula based upon the cylinder pressure and the centrifugal force of an assumed rod. The formula is necessarily to some extent an empirical one, as the strain due to cylinder pressure is exerted on the rod as a long pillar while the centrifugal force is acting transversely. The allowed fibre strain is about 12,000 to 14,000 lbs.

### LIFE OF A POP VALVE.

(92) J. D., of New York, asks: What is the average life of a spring pop valve?—A. This is rather a general question and cannot be answered accurately, as the life of the spring depends on various conditions, such as the character of the water and the climate, and there are other conditions which may operate favorably or against the valve.

### MODEL OF WALSCHAERTS VALVE GEAR.

(93) A. S. M., Hornell, N. Y., writes: The model of link motion made by your company is an excellent help to people studying link motion. Why do you not do something of the kind for the Walschaerts valve gear?—A.—We had some intention of having a working model of the Walschaerts valve gear added to our list of educational appliances, but a little study of the subject brought forward the fact that the Walschaerts motion cannot be changed after it is applied. On that account a model of the motion would not be of much use, and would not be in demand.

# Air Brake Department

## High Speed Brake.

Opinions have always been more or less conflicting concerning the difference between the high speed and low speed brake. The fact that a higher brake pipe pressure is maintained with the high speed brake does not necessarily mean that a higher brake cylinder pressure results from a 5 or 10 lb. reduction than does from the same reduction in the low speed brake pipe pressure. Since the triple valve delivers from the auxiliary reservoirs to the brake cylinder a number of pounds pressure equal to the amount

pipe pressure the full volume and pressure of the auxiliary reservoir is equalized with the brake cylinder pressure, which would naturally result in a higher brake cylinder pressure when the auxiliary reservoir pressure is 110 lbs.

## Effect of Water in E. T. Equipment.

On an engine equipped with the Westinghouse E. T. brake, the brakes were slow in applying and when applied with a full service reduction there would only be about 35 lbs. pressure in the brake cylinders. Since the engineer's brake

water had upon the E. T. equipment. But there are more evils than this with any air brake equipment when water is allowed to travel through the system, especially in cold weather. When the volume of the main reservoir is decreased the warm air, which will always hold more moisture than cold air coming from the pump, has not sufficient time and space to cool and precipitate the moisture in the main reservoir, where it can be easily and frequently drained away.

The warm air then goes into the brake pipe and triple valves, precipitating its moisture there to be frozen in cold weather, causing air brake failures.

## To Clean Paint.

The fireman interested in keeping the bright work of an engine shining is becoming rare, but there are some still at work and to these we give the following recipe for a compound good for cleaning paint:

To one gallon of water add one quarter pound of borax and half a pint of lard oil. Rub this upon the paint to be cleaned, then wipe off with clean waste or soft cloth. The wiping off must be done before the mixture gets time to dry. The writer has used the mixture successfully.

## Broken Air Pipes.

Editor:

Not many years ago a man that could put up pipe and fit it, make bends without kinking, and prided himself upon his ability to select a good location for joints and connections, was considered a good pipe fitter, but at the present time it appears that the man who connects two pieces of pipe in the shortest space of time, regardless of how it is done or how long it will stay connected, is the best pipe fitter in the estimation of the average engine house foreman.

It is not an unusual sight to see a pipe man on a locomotive in an engine house using a heavy iron bar to pry a piece of pipe to a position where it can be connected; sometimes two men are required on the bar.

This method of connecting pipe often results in the pipe being broken off in the threads later on, and it throws a twisting strain into a bent piece of pipe, which causes it to burst or split

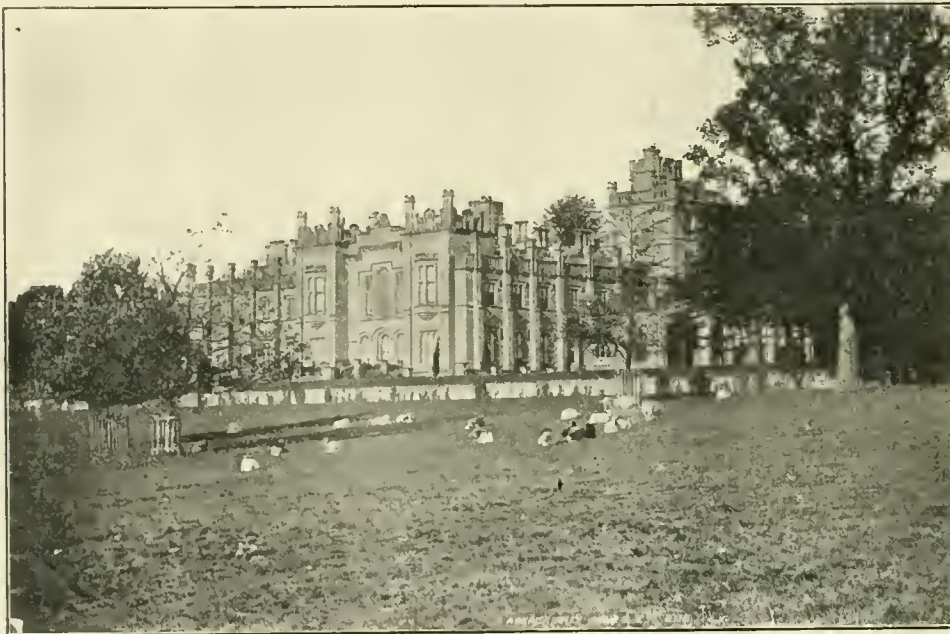

VIEW OF ABERCAIRNEY CASTLE, SCOTLAND.

of reduction in brake pipe pressure it is the amount of brake pipe pressure reduced that controls the brake cylinder pressure and not the number of pounds pressure maintained in the brake pipe when any reduction less than a full service or emergency reduction is made.

However, the stopping effect of a 10 lb. reduction in a 110 lb. brake pipe pressure may be greater than the same reduction in a 70 lb. brake pipe because there is 40 lbs. more pressure in the auxiliary reservoir to force the 10 lbs. into the brake cylinder, which will fill the brake cylinder faster, therefore bringing the brake shoes in contact with the wheels quicker and the full value of the brake cylinder pressure is realized sooner. The 10 lbs. is 10 lbs. just the same as though it came from a lower auxiliary reservoir pressure. But when a full service or an emergency reduction is made in the brake

valve reduced the air pressure in the brake pipe promptly it would be natural to look next to the distributing valve. The distributing valve was taken apart and found to be in good condition, working quite free. The plug was then removed from the pressure chamber, when considerable water ran out. The water in the pressure chamber decreased the volume of same, which would result in a lower equalization of pressure between the application and pressure chambers, therefore a lower brake cylinder pressure. As for the slowness in the application of the brakes it was due to long piston travel.

After the water was discovered in the pressure chamber the main reservoirs, which were as full of water as main reservoirs could be, were drained. From the foregoing it merely goes to show what effect not draining the main reservoirs of



in the seam, especially where an inferior grade of pipe is used.

In the air brake equipment, loose pipe clamps, loose brake cylinders and air reservoirs are the principal causes of broken air pipes.

Air pipes are liable to break off at any time while an engine is in service, and the engineer should know exactly what can be done under the circumstances to repair the break and again get the train in motion in the shortest possible space of time.

With the E. T. brake equipment there are very few cases of broken air pipes that will prevent the operation of the brakes on the train from the engine. A number of cases have occurred where the brake pipe connection to the distributing valve was broken off. It is not necessary to cut out the distributing valve and run the engine without a driver brake in this case. All that is necessary is to plug the brake pipe and proceed.

As the pipe breaks the equalizing valve of the distributing valve will be moved to the emergency position and will remain there with the piston forming a joint on the cylinder cap gasket, and the slide valve opens a communication between the main reservoir port and the pressure and application chambers of the distributing valve through ports m in the slide valve and n in the seat, allowing main reservoir pressure to flow from the distributing valve through the independent brake valve to the rotary seat of the automatic brake valve, and when the handle is placed in running position there will be a continual blow at the exhaust port.

When the valve handle is lapped or used in the service or emergency application positions the blow will stop and the pressure will build up in the application chamber to the adjustment of the safety valve.

This brake can be used in conjunction with the train brakes, and it will be noted that the driver brake releases very slowly, which can be hastened by the use of the independent brake valve.

Should the brake cylinder pipe break off at the distributing valve there would be no driver or tender brake, and it would be a waste of time to stop and examine it.

Should the application chamber pipe break off it could be plugged at the distributing valve and the double heading pipe disconnected to form an exhaust port for the application chamber, and the equalizing valve will perform the work of a triple valve during automatic applications, the holding feature and independent brake would be destroyed.

The double heading pipe is merely a blanked pipe which, if broken, can be

plugged or, if double heading, left disconnected on the second engine.

If the supply pipe is broken off it will only be necessary to close the cut-out cock which is located in this pipe, and the driver brake cannot be operated.

The cut-out cock for the distributing valve was formerly located in the brake pipe, but as the cock is now placed in the supply pipe it is only necessary to close the cock and start a leak in the brake cylinder pipes if the main piston should become stuck or broken in application position.

It is possible to handle the brakes on a train if any of the pipe connections to the H 5 brake valve are broken off from the brake valve; the most difficult proposition is the brake pipe.



WAITING FOR THE WRECKING CREW.

In a case of this kind it is first necessary to establish a communication between the main reservoir and brake pipe pressures. This can be done through the distributing valve, but we will have no driver brake.

As the connection breaks the brake valve will be placed in the emergency position to retain the pressure in the main reservoir. The stop cock under the brake valve can then be turned, or if the break is below the cock, plugged to stop the brake pipe leak.

The cut-out cock in the supply pipe to the distributing valve must then be closed and the pressure can be drawn from the application chamber by means of the independent brake valve, which will release the driver brake. The equalizing valve and piston can then be removed, care being taken to replace the cover with the gasket in its proper position.

The adjusting nut of the safety valve must be screwed down to create a

greater tension on the spring than the brake pipe pressure to be used, and the stop cock in the brake cylinder pipes closed.

Then by placing the handle of the independent brake valve in quick application position there will be a flow of air from the main reservoir through B 3 reducing valve, the independent brake valve and the application chamber of the distributing valve to the brake pipe, and the pressure can be set to any figure desired, 70 or 110 pounds, by means of the B 3 reducing valve.

The independent brake valve will then perform the functions of the ordinary three-way cock, separating the reservoir and brake pipe pressures while on lap or in running position, and making the brake pipe reduction

through its exhaust port when held in release position. When the hand is removed from the handle the return spring will move the handle to running position, stopping the flow of air from the brake pipe. When the handle is again placed in quick application position the brake pipe pressure will be restored and the brake released.

Care must be taken to close the stop cocks in all the brake cylinder pipes, or the driver and tender brake is likely to be applied by a flow of air through port n in the valve seat of the equalizing valve bushing, as the main piston will be in application position.

Should it be forgotten until after the brake pipe is charged it can be closed and a union disconnected in the brake cylinder pipe to bleed off the brake. Should there be no stop cock in the pipe the loss of air through the disconnected union would be inconsiderable, as the port n is very small.

If the reservoir pipe breaks off at

the H 5 brake valve it can be plugged and a blind gasket inserted at the union connection and running position used to release and recharge the brake pipe. If a slight leak exists at the joint or the rotary key gasket it will result in an occasional flash of air at the emergency exhaust port, due to the rotary valve being lifted from its seat, but the pressure will equalize instantly without affecting the operation of the brake.

If the feed valve pipe breaks the flow of air from the main reservoir can be stopped by unscrewing the adjusting nut of the B 4 feed valve, the union at the brake valve can be blanked and the pressure in the brake pipe maintained with the valve handle in release position. The lower connection to the S.F. 4, pump governor must also be blanked to prevent the governor from stopping the pump, as the air pressure that is combined with the spring pressure to hold the diaphragm valve of this governor to its seat is taken from the feed valve pipe.

If the equalizing reservoir pipe

application chamber by placing the S. F. brake valve handle in release position the main piston will automatically reduce the brake pipe pressure on the train through its exhaust port, and when the handle is again placed in the quick application the brake pipe pressure will be restored from the main reservoir and the brake released.

The reduction must be made almost continuous on account of the ports m and n, which build up the application chamber pressure. The black hand of the duplex gauge will show this pressure and the single pointer will show the brake pipe; the main piston will keep them equalized.

The special fitting in the tender brake cylinder pipe may retard the flow of air to some extent, but a service application and the release can be made through this choked passage on an ordinary passenger or freight train.

When air pipes connecting the air pump and main reservoirs are broken another engine is usually required to haul the train.

But it is well to remember that nip-



BALDWIN FRISCO 4-4-2.

breaks off, it and the train line exhaust can be plugged and the valve used same as the G 6 brake valve under similar conditions.

If the reducing valve pipe breaks off, the independent brake and signal whistle will be destroyed, but the adjusting nut of the reducing valve can be unscrewed, which will stop the flow of air from the main reservoir and the connection at the brake valve blanked. The handle of the independent brake valve should be allowed to remain in running position, so as not to interfere with the operation of the automatic brake.

The brake on a train of the ordinary length can be handled if the entire brake pipe is torn off the engine.

The H 5 brake valve must be placed in the emergency position, the safety valve screwed down to prevent a waste of air, and after the engine and tender brake is released the brake cylinder pipe on the engine can be connected to the train brake pipe on the tender by hammering the hose couplings together. The stop cock to the driver brake can then be closed and the S. F. brake valve placed in quick application position and the brake pipe pressure adjusted with the B 3 reducing valve.

As the pressure is reduced in the

plies in the air brake hose have a standard  $1\frac{1}{4}$ -in. pipe thread and will connect with any union, elbow or socket that is used in connecting the  $9\frac{1}{2}$ -in. air pump to the main reservoirs.

Washington, D. C. G. W. KIEHM.

#### Good Record by Engineers.

Results of so-called surprise tests for the observance of signals on two railroads in the West are of unusual interest owing to the fact that they have a long record of such tests and are making great extensions of the block signal system. With the 2,754 miles of automatic block signals authorized for installation this year, the Union Pacific and Southern Pacific will have 4,700 miles so equipped, and on the Southern Pacific there will be a 2,354-mile stretch of automatically blocked track.

Out of 1,196 tests, in only 16 cases was there failure to observe signals. Eighteen different kinds of tests were made besides some special tests, and the average for all is 98.7 per cent. All red flags, crossing, station and block danger signals were observed. A perfect record was shown in 12 out of the 18 classes of tests.

This is the fourth year of such tests

on the Southern Pacific and the third year on the Union Pacific lines. The tests are closely watched, the results of tests made by subordinate officers being reported to and examined by the division superintendent and then passed on to the general superintendent, the general manager, and finally to the director of maintenance and operation of these lines.

The tests are made under such conditions that the enginemen and trainmen cannot know what is being done. Two or more of each of 18 different kinds must be made on each division each month. These tests cover the use of torpedoes, fuses, slow and red flags, switch lights out and at danger, and all semaphore signals. It is not uncommon now, officials say, to receive reports from a number of divisions for an entire month, showing a perfect record under tests carried out to make sure that signals are being observed.

#### Put the Cow-Catcher Behind.

Many people are given credit for humorous remarks that originated with Artemus Ward. The slow speed of a Southern railroad is an instance.

A certain railroad in the South was in a wretched condition, and the trains were consequently run at a phenomenally low rate of speed. When the conductor was punching his ticket Artemus Ward, who was one of the passengers, remarked:

"Does this railroad company allow passengers to give it advice, if they do so in a respectful manner?"

The conductor replied in gruff tones that he guessed so.

"Well," Artemus went on, "it occurred to me that it would be well to detach the cow catcher from the front of the engine and hitch it to the rear of the train; for, you see, we are not liable to overtake a cow, and what's to prevent a cow from strolling into this car and biting a passenger?"

The Grand Trunk Railroad Company have lately applied the Mellin pneumatic reversing gear to several heavy locomotives they have recently built in their shops at Montreal. This reversing gear and that used by the Baldwin Locomotive Works are very simple arrangements of mechanism and perform their functions very smoothly. One or other of them ought to be applied to every heavy locomotive.

The Commonwealth Steel Company of St. Louis, Mo., have just moved into their new offices in the Pierce Building, opposite the Planters' Hotel in that city. The company has taken the entire southern wing on the sixteenth floor of the building.

# Patent Office Department

**TRACK SANDER.**

A pneumatic track sander has been patented by Mr. J. H. Walters, Augusta, Ga. No. 862,952. The device consists of a casing having a nipple at one end for attachment to a sand box and furnished at its opposite sides with lateral discharge openings. The body portion of the nozzle is bored out to form a recess, and an air jet passage

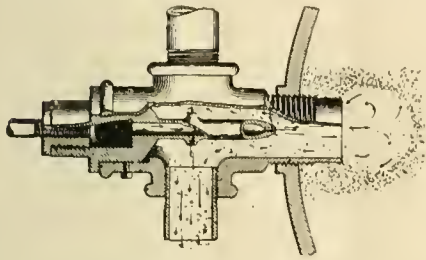

LOCOMOTIVE SANDER.

leads from the recess and opens at the end and sides of the nozzle. There is also a strainer disposed within the recess.

**SUPERHEATER.**

An improved locomotive boiler and superheater has been patented by Mr. H. H. Vaughan, assistant to vice-president of the Canadian Pacific Railroad Montreal, Can. No. 863,333. The device embraces a fire tube boiler, its fire box

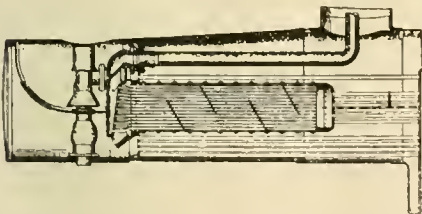

STEAM SUPERHEATER.

and smoke box, in combination with a shell of less diameter than the boiler, opening through the front flue sheet and extending a considerable distance towards the rear flue sheet. A plurality of flues connects the shell with the fire box. A group of loop tubes or pipes occupies the shell and extends part way to the rear end of the shell. There are suitable saturated and superheated headers to which the pipes are attached, and a plurality of deflector plates forms a tortuous passage for controlling the flow of fire box gases through the shell. There is also a movable closure beneath the superheater for closing the forward end of the shell.

**LOCOMOTIVE BOILER.**

Mr. H. J. Travis, New York, N. Y., has patented a locomotive boiler. No. 864,047. The boiler is furnished with a fire chamber and means for admitting pulverized fuel through the rear end of the fire chamber. A slanting baffle wall extends transversely across the interior of the fire chamber. There is a laterally extended chamber at the forward end of the fire chamber, with return fire tubes leading to the rear of the boiler and an up-take in communication with the rear ends of the fire tubes. There is also a chamber

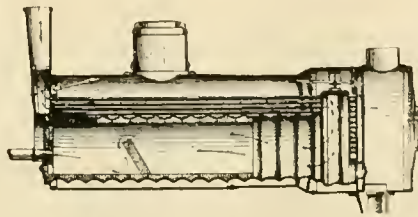

NEW LOCOMOTIVE BOILER.

at the front of the boiler cut off from the products of combustion for the reception of the exhaust steam.

**BOILER FLUE BLOWER.**

Mr. T. E. Hutchins, Beatrice, Neb., has patented an improved boiler flue blower. No. 863,538. It consists of a series of steam nozzles, a revoluble header carrying the nozzles, a stand pipe upon which the header is mounted

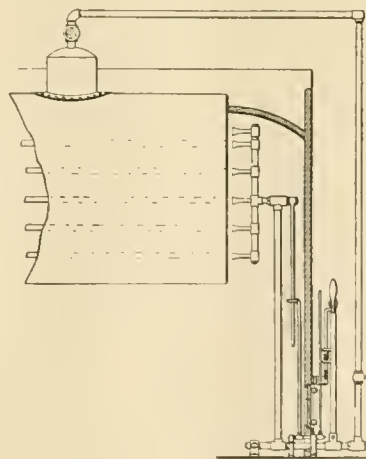

STEAM FLUE BLOWER.

and means for turning the stand pipe. A steam supply pipe is connected with the dome at one end and with admission pipes to the header at the other

end. A hand lever regulates the supply of steam through the hollow support of the stand pipe. The apparatus is readily adjustable to the flues.

**JOURNAL BOX.**

Mr. J. R. Schrader, Buffalo, N. Y., has patented an improved car journal box. No. 809,635. The device consists of a bearing block provided with oil pockets in its curved or under side, and openings leading through the block from the pockets to the top of the

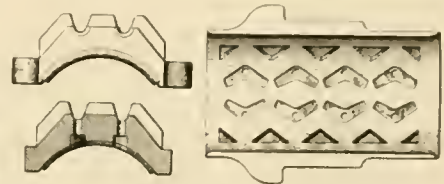

JOURNAL BEARING.

block, and grooves in the top of the block which communicate with the openings and terminate at the block ends over the axle. The rotation of the car axle fills the oil pockets and forces oil through the openings to the top, whence it flows through the channels and returns by gravity to lubricate the axle.

**Air Navigation.**

Certain people have been nervous lest in the near future electricity would do away with the steam locomotive. Now a new danger has arisen. Some French inventors have made a large balloon that can be steered. Years ago a favorite song in London music halls depicted the glory of being up in a balloon sailing round the moon. The sky sailor seems coming at last. But woe to the makers of steel rails when air navigation comes.

**Provision for High Speed.**

Concerning extraordinarily high vehicle speed, the *Railway Engineer* of London says: "The Brooklands track should act as a useful safety valve for the high-speed mania. It is some three to three and a quarter miles round, and wide enough for five cars to race abreast; the curves are banked up to 1 in 2½, and considerable skill and practice will be required to take the right height to suit the speed; but the track is in close proximity to a large cemetery and crematorium.

### Traveling Engineers' Association.

(Continued from page 456.)

Mr. Roesch did not want to be on record as holding that holes in smoke boxes did not affect the steaming of engines. He sustained all the recommendations of the report.

Mr. James S. Downing, Southern, favored road foremen of engines making thorough investigations when an engine was reported as not steaming. He would look for leaky flues and have flues thoroughly cleaned, valves squared, cylinder packing tight, the exhaust going out of the stack centrally, with the nozzles secure, and neither too large or too small. Wanted the road foreman or engineer given preference to any master mechanic or roundhouse foreman in looking for the cause of badly steaming engines. He was strongly in favor of every official attending to his own business.

Mr. Wallace was pleased with the idea of every man attending to his own business and leave other men alone. He favored keeping the front ends tight and all other parts in perfect order as the best means to prevent engine failures. Leaks in the smoke box connection can generally be detected by the discoloration of the paint. Thought the style of grate could be safely left to the builders of the locomotives. It is impossible to provide a set rule for grate, ash pan openings, stacks or any other part that would suit all conditions.

Mr. Conger spoke of the varying conditions of locomotive service and of the important duties the traveling engineers have to perform. With this class of men lies the duty to adjust locomotives to suit the varying conditions encountered.

Mr. Downing followed and spoke on similar lines to Messrs. Wallace and Conger.

The discussion was then closed with a vote of thanks to the committee.

#### WASTE OF ENERGY IN RAILROAD OPERATION.

This was an individual paper read by Mr. D. C. Buell, and read:

To the Officers and Members of the Traveling Engineers' Association:

Gentlemen: Energy is defined as the power by which anything acts effectively to move or change other things to accomplish any results, and energy is the prime factor in results accomplished on railroads, not only in the Motive Power Department, but in all branches. The energy stored in the coal must be used to make steam, the energy in the steam must be used to move the engines and pull the trains, and the energy stored in the men and officials must be used to properly regulate the whole. The law of the conservation of energy says that energy can neither be created nor destroyed; it may be changed from one form to another, however, and our problem is to convert the stored-up energy under our control

into useful work with as little waste as possible.

The word "waste," according to Webster, means to spend thoughtlessly, unnecessarily or without return, to cause to be lost through neglect or improvidence, to make prodigal or extravagant use of, to spend to no purpose.

The subject of this paper, "The Waste of Energy in Railroad Operation," shows that this association is keenly awake to the fact that large amounts of energy are being wasted day by day and that its members desire to know the channels through which this waste occurs and what practical remedies, if any, may be used to wholly or partially stop the leakage.

The energy wasted on railroads may for our purpose be divided into three classes:

First—Energy wasted by present well-established systems which, while known to be wasteful, nevertheless appear to be in some cases the only practical, or, in others, the most economical means to accomplish the desired results.

Second—Energy now wasted by improper systems of management or improper or uneconomical machines or devices of various kinds now in use, these being under the control of officials higher than the road foreman of engines.

Third—Energy now wasted either by improper systems of management or by improper methods of handling or working machines, or the improper condition of the machines themselves, over all of which jurisdiction of the Road Foreman of Engines extends.

The first and second of the above wastes may be touched upon but briefly. Of the actual energy known to exist in a pound of coal but a small per cent. is realized, the waste taking place in the slacking of the coal, the loss of heat due to improper combustion, the loss of heat in making steam, the additional loss from the steam itself, and the greatest loss in converting the energy in the steam into effective work in the locomotive.

Science has proven that the mechanical equivalent of one heat unit (B. T. U.) is 778 foot pounds of work, so that to produce one horsepower for an hour would require power equivalent to 2,545 heat units. One pound of coal when properly burned will give off about 14,100 heat units, or enough to produce five and one-half horsepower for one hour. In locomotive service it takes at the lowest estimate twenty-five pounds of water (steam) per indicated horsepower per hour. Neglecting the loss due to friction of the engine, this would mean that to produce five and one-half horsepower per hour in a locomotive would require 137½ pounds of water, and as one pound of coal evaporates only about five pounds of water in a locomotive boiler, 27½ pounds of coal would be required, that is, only 3.6 per cent. of the actual energy in the coal is

realized in this case, the other 96.4 per cent. being energy wasted, due to our method of converting the heat into work.

Practically all the improvements made in the past few years tending to better the economy of the locomotive have been along lines that at the most would save only a fractional per cent. of this great loss, but these fractional savings have amounted to hundreds of thousands of dollars in some cases. In view of this greater possibility of saving, efforts have been made for years to obtain power direct from coal without this wasteful method of making steam and converting the energy in the steam into power by means of the engine. So far no results have been accomplished, although in this age of scientific wonders it is safe to predict that some future Edison may revolutionize our present methods by obtaining electricity direct from coal by some chemical process which will allow practically all the energy in the coal to be converted into work with a very small percentage of loss.

With our present methods, however, the most economical results have been accomplished by having a large central power plant where boilers reach the highest efficiency in transforming the heat in the coal into steam and where highly efficient triple or quadruple expansion engines driving generators convert the power in the steam into electrical energy which can be transported long distances with small loss and used in motors for practical power purposes. Railroad managers, realizing the economy of this method, are now experimenting on and perfecting systems of this kind to supplant the individual power plants which each of our locomotives now represent and which in comparison to this new system they feel are wasteful.

Other experiments are being made with explosive engines, principally gasoline engines, where power is required in small units, in thinly settled territories. This method often shows a large saving on account of the economy of gas engines over steam. It is doubtful, however, if the gas engine will be used extensively in railroad work except for special service on account of the many seemingly impractical features connected with its use.

Aside from the method of generating power its use must be considered. The grade line of the road may be such that a very large amount of power is wasted. Possibly a small expenditure on grade reduction would more than pay for itself in power saved. The method of handling tonnage is also to be considered, as when the rating is too light energy is wasted by not using the machinery to its economical capacity, and, vice versa, if an engine is overloaded energy is wasted in slipping, stalling, in doubling hills and due to the much slower rate of speed

at which train is moved, which is a controlling factor in considering the amount of energy wasted. The type of steam engine used is a factor also, some roads using very large and powerful engines, others using small power, some with compound locomotives, Walschaerts valve gear, superheaters and other devices, all endeavoring to give greater economy and better service.

Each type of engine, valve gear or special device, if it has merit, shows its greatest economy under certain special conditions, and in order to save rather than waste, careful consideration should be given to the selection of not only the locomotive, but the special devices on it, to insure having a machine that will be economical under the conditions under which it will have to work. The track conditions in a great many cases are such that the friction or train resistance of the cars passing over it is greatly increased over what it would be were the track properly maintained. All increased resistance of this kind, of course, means a corresponding waste of power.

The foregoing cases are what might be called fundamental wastes on a road, that is, they are determined by the physical condition of the road, the class of power and equipment and the fixed policy of the management. There are numerous other wastes, however, that the road foreman of engines is directly interested in and which he can reduce to a minimum. There is a possibility of a large loss of energy due to improper lubrication of locomotives and cars. The subject has been so thoroughly worked up by the different oil companies that there is no question but what the amount of oil generally allowed for an engine or car is sufficient if properly used or applied. A waste of energy will occur, however, if the matter is not properly attended to. Dry valves on a locomotive will make a difference of 25 to 50 tons in the train load than can be hauled over the grades, and there is reason to believe that the waste would be greater in proportion on a comparatively level road. Hot pins, eccentrics, driving boxes, etc., cause waste through increased friction of the parts, although the loss of time caused is a much greater and more costly item than the loss through increased friction; the same is true of hot boxes on trains due to improper lubrication.

The problem of fuel consumption or better combustion of fuel is another serious matter. On most roads there is no one man who is held accountable for the amount of fuel used. It would seem that there is room on a railroad to-day for a man whose title might be Fuel Superintendent, who would have charge of and direct the work now done by the Fuel Agent, including inspection of coal and the assignment of certain grades of coal to various coaling stations. He would

be so closely in touch with the mechanical department that he would be able to advise what class of coal was to be furnished each division point, so that engines might be drafted for the class of fuel to be burned, and he would have on his staff a corps of traveling firemen to see that the men were properly instructed concerning the principles of combustion and were firing their engines according to correct principles, and that the engines were drafted so that they would burn the fuel in an economical manner when properly fired. Such a man should be able to effect a wonderfully large saving when it is considered that to-day the Fuel Agent in some cases is trying to make a record by buying cheap fuel and will not admit there is such a thing as poor coal. The Mechanical Department, to avoid steam failures, is drafting engines to handle the poorest fuel, and the men on account of poor coal, improperly drafted engines or lack of interest are burning from 10

Coal wasted on account of being not being properly done.

#### HEAT WASTED ON ACCOUNT OF:

Ash pans not properly made for admission of air to give proper combustion or not kept cleaned out.

Engines not drafted right to give proper combustion.

Boilers or flues being dirty.

Steam leaks in fire box or front end that interfere with the proper combustion of the fuel as well as wasting heat by the leakage.

Forcing the fire too hard, drawing the gases out of the stack at too high a temperature.

Engines not properly lagged.

Heat wasted which might be saved by hollow fire brick arches, combustion tubes, feed water heaters or special devices of this nature that have been proven economical.

#### STEAM WASTED DUE TO:

Valves or cylinder packing blowing



THE MODERN HIGHWAY OF COMMERCE.

to 20 per cent. more fuel than necessary.

Of other channels through which energy is wasted may be mentioned the following:

#### COAL WASTED.

Coal not properly inspected at the mines, allowing slack and dirt in considerable amounts to take up space in cars, tanks and fire boxes that the coal should occupy, to say nothing of the loss caused by dirty fires, clinkers, etc.

Coal spilled at coal chutes and not picked up.

Coal stolen all along the line.

Coal wasted on account of improper or wasteful methods of firing up engines at the roundhouse.

Coal spilled from engine tanks being filled too full.

Coal spilled from engine deck on account of its not being kept clean.

Coal wasted through grates on account of the fireman shaking grates improperly.

Cylinders not smoothed. That is, where the inside of the cylinder wall has not become glazed so as to reflect the heat and keep it in the cylinder, instead of absorbing it and radiating it out as a cylinder which is pitted or unglazed will do.

Leaks across steam passages.

Leaks in steam valves.

Pipes or fittings leaking, either on the engine or in the cab.

Improper location or piping or working of the injectors.

Air leaks on the engine or cars.

Steam heat leaks.

Hot water leaks at any point from boiler or fittings.

Steam wasted through the pops on account of the engine not being fired properly.

#### POWER WASTED ON ACCOUNT OF:

Valves set improperly.

Lack of lubrication.

Improper feeding and firing of the boiler.

Improper running and handling of the engine.

Drafting the engine so as to give excessive back pressure.

Improper handling of the air.

Brakes set up too close.

The waste of time on a railroad is almost always accompanied by a waste of energy because cars, engines and men are lying around when they might be doing useful work.

#### TIME WASTED AT ROUNDHOUSE DUE TO:

Engineers not making proper work reports. Some one has said that the word "examine," as used by engineers on work book reports, has cost the railroad companies hundreds of thousands of dollars. Get your men to make correct work reports.

Inefficient or insufficient force not getting work done promptly, thus delaying a \$15,000 machine for want of a machinist or helper.

Sand-house, coal-chute, water tank and cinder pits not properly arranged. If you study your terminal you may be able to suggest some improvement in the layout that can be made at reasonable cost and would save more than enough in the cost of handling engines to pay the expense.

Lack of proper supplies at storehouse, requiring engineers to hunt up foremen and then spend more time robbing other engines to get what they want.

Lack of tools on engines, so that engineers cannot do necessary work promptly. A good locker room where tools, oil cans and overalls can be locked up will save most of this trouble.

Employing a boy who cannot be depended upon to do calling, when a few dollars more a week would pay for a man who would have some judgment and discretion and would save five times that amount in terminal overtime.

Not having a proper record of where men live and can be called.

Not having extra men enough to keep power moving as fast as ready and wanted.

Not having men called in time so they can get ready to go out on their call.

#### TIME WASTED ON ROAD DUE TO:

Not having proper tools on engines in case anything happens.

Trying to spot an engine at water tank with a long train instead of stopping short and cutting the engine off.

Not having fire in condition to go after meeting a train or getting orders.

Not oiling around promptly.

Engineer and conductor not working together to make meeting points or figure on station work.

Careless handling of train and pulling out draw-bars and bad ordering cars.

Not watching for signals from train crew.

Not having a supply of sand at con-

venient points between terminals for bad weather or emergencies.

Engines not properly washed out, causing foaming and consequent loss of tonnage or time.

Allowing coal to get in tanks, stopping up injector supply pipes.

Not cleaning strainers in injector supply pipes at frequent intervals.

Water accumulating in main reservoir, thus requiring a longer time than necessary to release brakes.

Not keeping sanding devices in good working order, with result that engine slips badly in starting train or on hard pulls.

Engineer and fireman not working together so they will have steam and water where needed.

Fireman not awaking to the fact that ash pan needs cleaning until engineer and train crew are ready to go.

nothing wrong with his engine when he knows he could not make ten miles an hour with the train. Do not let your men get false ideas about not admitting there is anything wrong so the train can be reduced if necessary.

There is a great deal of energy wasted in the yard and on the road directly chargeable to the Transportation Department, part of the cost of which in many cases falls on the Mechanical Department. For example, time wasted in not having trains made up, crews ready or the yard open so the engine can get to the train and get out on call.

Indifference in matter of switching coal to chutes, cars of company material to the rip track or roundhouse, switching bad orders to the rip track and pulling and setting rip tracks properly, pulling cinder track, etc. Along this line may be mentioned the seeming delight

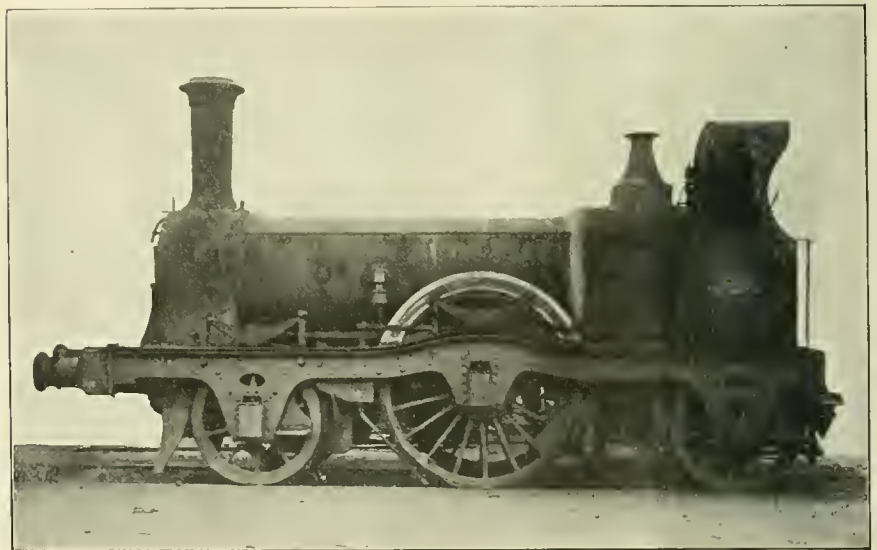

AN OLD-TIME SHARP "SINGLE."

Engineer laying down when something goes wrong with his engine when with a little thought and some energy he could have fixed things and brought his train in.

Crew stopping to eat just where it suits them without notifying the dispatcher or regarding the possible disarrangement of his plans.

Engineer or conductor not advising dispatcher if anything is going wrong so they cannot make the time expected of them. This hurts the other fellow at meeting points and maybe ties up the road.

Engineer not willing to admit there is anything wrong with his engine, resulting in long arguments between engineer, conductor and dispatcher with consequent waste of time. This is due in many cases to the fact that the engineer is "burned up" so badly if he admits an engine failure that he will deliberately say there is

some switchmen take in blocking the roundhouse leads, so engines cannot get in or out.

There is also time wasted getting the bills and orders, all of which is reflected in cost of coal charged against engines and wages of enginemen, etc.

On the road there may be waste due to poor distribution of time on schedules, poor dispatching, slow orders out which should have been cancelled, orders put out at points where it is hard to stop and start when some place where train would have to stop for water or a meeting point could have been used just as well.

Another waste is due to trains being made up improperly, loads behind instead of ahead, empty car doors open, short loads in what is supposed to be a through train, etc.

Slow orders put out by the Maintenance Department also add to the fuel

bill, because unfortunately they are usually necessarily placed on track just at the foot of a grade or on a curve on some hard pull.

Many water tanks are located so that it is up-hill both ways away from them. Of course, the streams are usually found at the bottom of hills, but it is cheaper to pump water to a tank at the top of the hill than to pull the train from a standstill to the same point; stations are located so the train has to be stopped on a curve, and sidetracks so that with a full train the brakeman has to jump off and sprint for the switch, because "if they stopped they would have to double in."

While many of the above conditions unfortunately exist on many lines, the Road Foreman has troubles enough of his own without the addition of anything outside his department, but it is always well to keep one's eyes open to such things in case a controversy should arise requiring explanation.

There still remains the large amount of human energy which is wasted that, though last, is not least. Some one has said that "the eye of the master is worth the hands of all the servants." What a waste it is to have the Master Mechanic walk back and forth from office to office four or five times a day when a telephone would save him that time, and think of the two or three months' old correspondence the Road Foreman must answer, many times in long-hand, when he might be out on the road with some new man or new engine, saving energy instead of wasting it. Work should be so arranged that it would not be necessary to keep a high-priced man doing cheap jobs. Following this same thought, some roads are noted for their prompt and courteous service and the fine discipline and loyalty of their men. Is it not due to good management, fair treatment and an example of loyalty, courtesy and fairness among their officials? The old saying, "Like master, like man," is true on railroads as elsewhere, and the waste of energy among a set of men who are not disciplined, are not loyal to the company or courteous to its patrons, is perhaps the greatest loss of all.

In view of the many ways in which energy may be wasted it may seem surprising that there really is any left. Most of the conditions that have been mentioned are self-explanatory and are not brought out in a spirit of criticism, but merely to call attention to the fact that while one or two of them alone would make a small item, nevertheless a man must be alert and watchful to keep them down to a minimum for waste is a prolific creature and unless watched and controlled increases and multiplies to such proportions as to ruin good men's careers and wreck good roads.

D. C. BUELL.

#### DISCUSSION.

MR. MARTIN WHELAN (Big Four): The waste of fuel was mentioned. Next to the item of wages fuel follows, the second largest expense that we have to contend with.

Now after the Road Foreman of Engines has followed these engines and found out that they are working as well as could be expected, when the monthly bulletin comes out there is sometimes a bad showing there on the bulletin. I got up against that some years ago. The Superintendent of Motive Power wrote a very bitter letter and wanted an explanation. The fact was that I was unable to explain it. I started in at the Chief Clerk's office to look over the records. I had charge of two divisions. I found out that a coal dock on one division there were 265 tons over, which showed that the engines had been charged up with less coal than they got. The car record showed that they had received 265 tons that was not shown in the coal dock report. At another coal dock on the other division they were 520 tons short. After spending two days and a good part of two nights going over the records, I found that in order to square the report to send in to the Superintendent of Motive Power's office, they had shifted the 265 tons over on the one division to the coal dock where they were 520 tons short, in order to try to square up the shortage. The engines had run on one division; never got over on the other. When you get up against something of that kind, you are up against a stiff proposition, and you can ride engines from the first of the month till the last of the month and you won't be able to explain, unless you go clear to the bottom, and you can't be riding engines while you are going through the reports. In addition to that, I found twenty-eight mistakes in the figures that changed, materially changed, the records of different engines. That is something that a Road Foreman of Engines has to contend against, and he cannot figure it out by riding engines.

(Report of proceedings to be continued.)

#### Effort Very Successful.

A Scots railroad man who was of slightly convivial habits went home late one night and wishing to make as little disturbance as possible searched about in the dark for something to eat. He found what tasted like cold cabbage and made a hasty meal. In the morning his wife asked, "What did you eat, Jim, when you came in so late last night?" "I found a dish of cold cabbage in the kitchen and ate some of it." "Cabbage, you donkey, why that was a dish of collars I put in water to soak." "That is too bad. I thought you had steeped very tough cabbage."

#### Oak Leaves and Other Leaves.

A pocket book of useful information, got up in most convenient style, can be had by mailing a postcard request for one. The little book measures  $4\frac{1}{4}$  by  $2\frac{1}{2}$  ins. and has a celluloid cover on which are oak leaves in autumn tints. The smooth cover permits the book to slip easily into the pocket, but the facts it contains will not so easily slip away. It has a calendar for this year and the two following. It gives the antidotes for poisons and some useful hints for rendering aid in case of accidents, such as the procedure in case of apparent drowning, and here it may be stated that serious cases of electric shock should be treated in the same way. There are bridge whist scores and simple rules for playing whist. Interest tables and legal holidays, population statistics and measures of length, square and cubic, and ordinary metric equivalents. Furthermore there are useful numbers and rules for finding the circumference and area of circles, the volume and surface of spheres, weight of water, capacity of pipes and many other facts "too numerous to mention."

There is a page for your name and address, which if not immediately useful to yourself, may be to others in case of accident. There is a list of your personal dimensions, if one may call them so, which when you write them down once, are there for keeps unless you keep on growing very fast. They are useful to know without having to measure yourself up in a hurry. They are the size of your hat, your gloves, your socks, your collars, cuffs and shoes. The other personal dimensions are useful whether you grow or not and are, maker and number of your bicycle or automobile, your watch number, your watch works number, bank book number and your height and weight at the date you may write down. We have not space to mention all the facts and figures given, but we may say they are constantly wanted by the ordinary "man in the street." There are a number of blank pages for notes and memoranda, and if you write to H. B. Underwood & Co. of Philadelphia, the makers of portable tools for railway repair shops, they will send you a copy of this pocket book with the autumn leaves on it and the other leaves with information on them.

#### Hill Climbers.

Mr. A. Borsig, the distinguished German engineer, has just issued an interesting catalogue, No. 1157. It illustrates his specialty in Raek-locomotives, and furnishes descriptive letter press and photographic views of the different kinds of hill-climbing engines. Many of these are

engaged in the service of the Prussian State railways, and a number of others are shown at work in the Andes Mountains in Chile. The locomotives are mostly of the medium weight, with tank encircling the engine. The Rack mechanism is fully described. The engine works are located at Tegel, Berlin, Prussia.

#### Oil Burning Mogul.

The Galveston, Houston & Henderson Railroad have some oil burning engines on their line, of the 2-6-0 type. These engines were built by the Baldwin Locomotive Works and weigh each 139,885 lbs. The cylinders of these engines are 19 x 26 ins. in diameter and the driving wheels are 62 ins. and carry a weight of 121,315 lbs., which leaves 18,570 lbs. on the pony truck in front. Taking 85 per cent. of the boiler pressure as the mean effective pressure in the cylinders, these

There are 280 tubes, each 11 ft. 6 ins. long. The grate area is 277 sq. ft., and this gives an approximate ratio of grate to heating surface as 1 is to 65. The steam pressure is 200 lbs. to the sq. in., and the fuel is crude oil.

The tender is of the ordinary type in appearance, and is carried on a structural steel frame, and has ordinary arch bar trucks. The water capacity of the tank is 5,000 gallons, and fuel oil to the amount of 2,100 gallons is carried. The service required of these engines is passenger and freight. Some of the principal dimensions are as follows:

Boiler—Material, steel; thickness of sheets,  $\frac{5}{8}$  and 11-16 in.; staying, radial.  
 Firebox—Material, steel; length, 96 3-16 ins.; width, 41 3/8 ins.; depth, front, 71 3-16 ins.; depth, back, 59 13-16 ins.  
 Thickness of Sheets—Sides, 5-16 in.; back, 5-16 in.; crown,  $\frac{3}{8}$  in.; tube,  $\frac{1}{2}$  in.  
 Water Space—Front, 4 ins.; sides,  $3\frac{1}{2}$  ins.; back,  $3\frac{1}{2}$  ins.

After business had been transacted the committees received an invitation from Mr. G. A. Morrison, representative of the Garlock Packing Co., of Palmyra, N. Y., which was accepted and all found Mr. Morrison a pleasing and delightful entertainer.

The following are the names of the Executive Committee: Mr. C. H. Voges, chairman, Bellefontaine, Ohio; Mr. L. H. Bryan, secretary, Two Harbors, Minn.; Mr. E. C. Hanse, Savannah, Ga.; Mr. Wm. Hall, Escanaba, Mich.; Mr. E. R. Berry, Galesburg, Ill.

#### Curious Train Protection Signal.

The Prussian railway authorities have been making experiments on the line between Berlin and Stettin to find a method for insuring the efficiency of signals, and thus preventing accidents. In the effort to obtain a preliminary

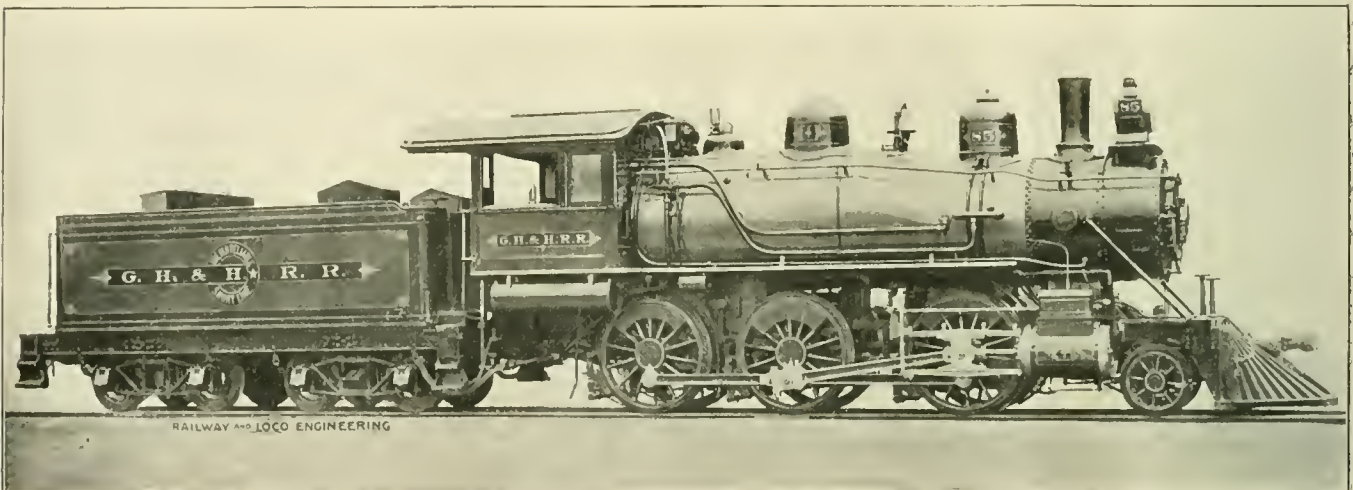

MOGUL ENGINE ON THE GALVESTON, HOUSTON & HENDERSON RAILROAD.

W. M. Paul, Master Mechanic.

Baldwin Locomotive Works, Builders.

engines have a calculated tractive effort of about 25,700 lbs., and with the weight on the drivers as stated the factor of adhesion becomes 4.7.

The valves of this engine are the ordinary D-slide, balanced, and they are driven by the shifting link motion. All the wheels are flanged, the pony and the leading drivers being equalized together, and the main and rear drivers together. All the rods are of I-section. The wheel base of the engine is 21 ft. 10 ins., and the rigid base is 14 ft. When the wheel base of the tender is added the total becomes 50 ft., and both together weigh about 240,000 lbs.

The boiler of this engine is of the wagon top type, the taper sheet being the second course. The diameter of the boiler at smoke box end is  $60\frac{1}{4}$  ins., and the liberal taper of the gusset sheet gives considerable water and steam space over the fire box. The total heating surface in the boiler is 1,815 sq. ft., made up of 1,672 sq. ft. in the tubes and 143 in the fire box.

Tubes—Material, iron; wire gauge, No. 12; diameter, 2 ins.

Driving Wheels—Journals, main, 8x9 ins.

Engine Truck Wheels—Front, diameter, 33 ins.; journals, 5x10 ins.

Tender—Wheels, diameter, 36 ins.; journals, 5x9 ins.

#### General Foremen's Association.

The Executive Committee of the International General Foremen's Association held a special meeting on August 25th and 26th at the Palace Hotel in Cincinnati, Ohio, by order of Chairman Mr. C. H. Voges. The purpose of this meeting was to discuss important business for the association which could not have been successfully accomplished by correspondence. It was decided that the next convention of this association will be held at Chicago, Ill., some time in May, 1908, definite dates will be given later. The intention is to make the next convention of the I. G. F. Association the most successful one ever held.

signal to give warning of a stop signal many devices were tested. These included flashlights by the side of the track when nearing a signal and other visible signs. Electric wave transmission to the locomotive also was tried. The method finally selected consisted of fastening two or three horns with a rubber bulb, similar to those used on automobiles, to the telegraph poles at intervals of about 100 yards. These are electrically operated, and have been found trustworthy in warning engineers. The railway authorities have already decided to introduce these preliminary signals on a number of roads.

In an editorial article published in the *Rail Road Advocate* in 1854 strong arguments were used against the growing practice of running trains at night. The writer considered that the use of trains running from twenty to thirty miles an hour in day time accelerated journeys so much that everybody could afford to rest during the hours of darkness.



# Items of Personal Interest

Mr. R. E. Fulmer has been appointed master mechanic of the Illinois Central, with office at Denver, Col.

Mr. Wm. H. Sloat has been appointed foreman of the general shops of the Wheeling & Lake Erie at Lima, Ohio.

Mr. Geo. J. Duffy has resigned as master mechanic of the Canada division of the Michigan Central at St. Thomas, Ont.

Mr. E. H. Harkins has been appointed master mechanic on the Denver & Rio Grande, with headquarters at Salida, Col.

Mr. John Harding has been appointed traveling engineer between Harve and Cut-Bank, Mont., on the Great Northern Railroad.

Mr. J. C. Wilkinson has resigned as general foreman of the Shawnee, Okla., machine shop of the Chicago, Rock Island & Pacific.

Mr. Wm. West has been appointed traveling engineer between Williston and Minot, N.D., on the Great Northern Railroad.

Mr. R. L. Doolittle has been appointed assistant master mechanic on the Central of Georgia Railroad, with office at Macon, Ga.

Mr. J. M. Fulton has been appointed master mechanic on the Mexican Central Railway at Aguas, Mex., vice Mr. W. E. Morton, resigned.

Mr. F. W. Peterson has been appointed master mechanic on the Chicago & North-Western with headquarters at Green Bay, Wis.

Mr. C. James has been appointed master mechanic on the Erie Railroad with office at Port Jervis, N. Y., vice Mr. G. A. Moriarity, resigned.

Mr. George G. Milne has been elected secretary of the Gould Coupler Company of New York, at a special meeting of the Board of Directors.

Mr. A. Stukey has been appointed assistant general foreman of the general shops on the Wheeling & Lake Erie, with office at Lima, Ohio.

Mr. Chas. Schumacker has been appointed traveling engineer between Glasgow, Mont., and Williston, N. D., on the Great Northern Railroad.

Mr. J. J. Curtis has been appointed general foreman of locomotives and cars on the Chicago Southern Railway with headquarters at Fathom, Ill.

Mr. J. A. Lewis has been appointed master mechanic of the Monterey division of the Mexican Central Railway, vice Mr. R. D. Gibbons, transferred.

Mr. S. H. Lewis, formerly foreman of machinists of the Seaboard Air Line at Norfolk, Va., has been appointed master mechanic of the Virginian.

Mr. W. A. Bedell has been appointed master mechanic on the Missouri Pacific Railway with office at Van Buren, Ark., vice Mr. B. Donahue, resigned.

Mr. A. S. Grant has been appointed master mechanic of the Texas Central, with headquarters at Walnut Springs, Tex., vice Mr. N. L. Smithman, resigned.

Mr. L. Crassweller, formerly assistant purchasing agent on the Northern Pacific, has been appointed purchasing agent on that road, with headquarters at Tacoma, Wash.

Mr. R. A. Johnson has been appointed master mechanic of the Chihuahua division of the Mexican Central Railway at Aguas, Mex., vice Mr. J. M. Fulton, transferred.

Mr. J. T. Johns has been appointed master mechanic of the Valley division of the Missouri Pacific with office at McGehee, Ark., vice Mr. W. L. Calvert, transferred.

Mr. F. P. Huntley has been elected vice president and general manager of the Gould Coupler Company of New York at a special meeting of the Board of Directors.

Mr. A. H. Gairns has been appointed master mechanic of the Denver & Rio Grande Railroad with headquarters at Salt Lake City, Utah, vice Mr. E. G. Haskins, transferred.

Mr. Thomas Yeager has been appointed master mechanic of the Illinois Southern Railway, with headquarters at Sparta, Ill., vice Mr. M. W. Fitzgerald, assigned to other duties.

Mr. A. H. Eager, formerly general foreman on the Canadian Pacific Railway at Calgary, Alta., has been appointed district master mechanic on the same road, with office at Kenora, Ont.

Mr. E. S. Fitzsimmons, formerly general foreman boiler-maker of the Erie, has been appointed master mechanic on that road with headquarters at Galion, O., vice Mr. C. James, transferred.

Mr. M. S. Monroe, formerly general foreman of locomotive repairs, has been appointed master mechanic on the Chicago, Lake Shore & Eastern, with headquarters at Joliet, Ill.

Mr. S. A. Walker, formerly assistant superintendent, has been appointed superintendent of the Great Northern Railroad, with headquarters at Glasgow, Mont., vice Mr. McNaught, resigned.

Mr. C. J. Longbotham has been appointed general agent for the freight department of the Chicago Great Western Railway, with headquarters in Duluth, Minn., vice Mr. C. D. Thompson, resigned.

Mr. B. H. Gray, formerly master mechanic of the New Orleans Terminal, has been appointed superintendent of motive power of the Mobile, Jackson & Kansas City Railway, with office at Mobile, Ala.

Mr. H. C. Ettinger has been appointed master mechanic of the Decatur and Springfield divisions of the Wabash Railroad Company, with headquarters at Springfield, vice Mr. E. F. Needham, promoted.

Mr. J. H. Sayle has been appointed general agent for Wisconsin and the Northern Peninsula of Michigan of the Chicago Great Western Railway, with headquarters at Milwaukee, Wis., vice Mr. W. H. Lord, resigned.

Mr. C. E. Croom, formerly general foreman on the Atlantic Coast Line Railway, has been appointed master mechanic for the South Georgia Railway and West Coast Railway, with headquarters at Quitman, Ga.

Mr. W. L. Calvert, formerly master mechanic of the Valley division of the Missouri Pacific, has been appointed master mechanic of the White River and Memphis divisions on that road, with office at Carter, Ark.

Mr. R. D. Gibbons, master mechanic of the Monterey division of the Mexican Central Railway, has been transferred, holding the same position on the Aguas Calientes division of the same road, vice Mr. Fulton, resigned.

Mr. W. F. Ackerman, formerly superintendent of shops of the Chicago, Burlington & Quincy at Havelock, Neb., has been appointed assistant superintendent of motive power on the same road with headquarters at Lincoln, Neb.

Mr. J. F. Bowden, formerly general foreman of the locomotive department of the Baltimore & Ohio Railroad at Trinidad, has been appointed master mechanic on the same road, with office at Parkersburg, W. Va., vice Mr. J. P. Dorsey, resigned.

The following officers were elected at the convention of the Master Car and Locomotive Painters' Association recently held at St. Paul, Minn.: Mr. B. E. Miller, president, Delaware, Lackawanna & Western, Kingsland, N. J.; Mr. Geo. W. Warlick, first vice-president, Chicago, Rock Island & Pacific Ry., Chicago, Ill.; Mr. John D. Wright, second vice-president, Baltimore & Ohio Ry., Baltimore.

Md.; Mr. Albert P. Dane, secretary and treasurer, Boston & Maine Ry., Boston, Mass.

The following officers were elected at the Traveling Engineers' Association at the meeting recently held in Chicago: Mr. A. M. Bickel, of the Lake Shore & Michigan Southern, president; Mr. J. A. Talty, of the Delaware, Lackawanna & Western, first vice president; Mr. C. F. Richardson, of the St. Louis & San Francisco, second vice president; Mr. F. C. Thayer, of the Southern Railway, third vice president; Mr. W. O. Thompson, of the New York Central, secretary, and Mr. C. B. Conger, treasurer.

Mr. E. F. Needham has been appointed superintendent of the locomotive and car department of the Wabash Railroad Company, with headquarters at Springfield, Ill., vice Mr. J. B. Barnes, retired. Mr. Needham commenced work with the Wabash Railroad as apprentice at Ft. Wayne shops in 1880; he was promoted to foreman at Ft. Wayne in May, 1884, then transferred to Springfield, Ill., as foreman in January, 1899. In December, 1901, he was transferred to Decatur, Ill., as assistant master mechanic and again was transferred as assistant master mechanic to Ashley, Ind. In October, 1902, he was appointed master mechanic of the Eastern divisions in Springfield, Ill., and in March, 1906, was appointed master mechanic of the Decatur and Springfield divisions.

After sixty years' continuous service on railroads our old friend Orlando Stewart retired on October 1st from the position of superintendent of motive power of the Bangor & Aroostock Railroad, to spend the remainder of his days enjoying a life of leisure, where he will have the satisfaction of watching others toil in wrestling with the harassments that seem never to be absent from the motive power departments. Mr. Stewart was an excellent mechanic and rose by the force of skill to be master mechanic of railroad shops of a minor road, now part of the Boston & Maine system. He was an active and industrious member of the Master Mechanics' Association of which he was treasurer for many years. His numerous friends will wish that he live many years to enjoy the leisure he has so well earned.

#### Obituary.

It is with regret that we record the death of Chas. E. Main, general foreman of the Grand Trunk Western shops at Battle Creek, Mich., which occurred on September 4th. Mr. Main was a thorough mechanic, having served his apprenticeship in the Grand Trunk shops at Fort Gratiot and working for a time in the drawing office at that place. He was unassuming and courteous and was held in high esteem by both the company's officers and those subordinate to him.

#### Opening of the Old Colony Railroad.\*

By W. A. HAZELBOOM.

Regular daily train service commenced November 10, 1845, on the Old Colony Railroad, but it was on Saturday, November 8, that the directors and stockholders of this corporation with a large number of invited guests made an excursion to Plymouth to celebrate the official opening of the road, it being the first time that a train of cars had run the whole distance. The train left the station at South Boston drawn by two locomotives bearing the expressive names Miles Standish and The Mayflower, a third engine owned by the company bearing the honored name of Governor Carver, was on this day assigned to the humble but useful work of hauling gravel to complete unfinished places in the roadbed. The train consisted of thirteen cars, which were built by Bradley & Rice, of Worcester, and were described in the newspaper reports of the day as neat, beautiful and remarkably comfortable and easy. At the different stations along the line, other guests joined the company, and by the time they arrived in Plymouth the party consisted of about 800 in all. Notable among the guests were John Quincy Adams, ex-President of the United States; Hon. Daniel Webster, the venerable Judge Davis of Boston, John Davis of Worcester, several of the clergy and the officers of other railroad corporations.

At all the towns and settlements along the road flags were hoisted and the people were assembled to witness the novel procession and salute it with the roar of cannon, cheers, waving of flags and handkerchiefs and other demonstrations of satisfaction, the whole line of the railroad presenting a gala day appearance. At Abington a large number of children were drawn up in a line to greet the party, and at this place a band of music joined it. On arriving at Plymouth the whole company marched under escort of the band to Pilgrim Hall, which, in the language of a scribe of those days, "was opened and warmed with good fires for the occasion." After the excursionists had vacated the cars a large party of ladies, gentlemen and children of Plymouth, by invitation of the railroad officials, were taken on board the train and treated to short excursions.

At Pilgrim Hall, Jacob H. Loud, Esq., of Plymouth, made a short address of welcome, alluding to the en-

terprise of the company which had in less than a year from the time of first breaking ground on the line of the road been able to complete it sufficiently to allow the commencement of regular service. He concluded his address by inviting the gentlemen present to partake of a light collation which had been prepared at almost a moment's notice and which was intended, without ostentation, as an expression of hearty welcome to that ancient town. The company then retired to the lower hall, where tables were spread and where they found cold meats and other refreshments, prominent among which was plenty of hot chowder made from cod fish and clams, famous Pilgrim dishes which proved most acceptable and popular with these modern Pilgrims, judging from the energy with which they were attacked, as stated by the scribe already quoted.

Toasts were responded to and addresses made by the Hon. John Quincy Adams, Hon. Daniel Webster, Josiah Quincy, Jr., Esq., E. Haskett Derby, Esq., P. P. F. Degrand, Esq., Judge Davis, and others. Several of the speakers alluded in impressive language to the contrast between the festive occasion of their arrival in Plymouth and that of the Pilgrim fathers who 225 years before had first set foot upon the bleak and lonely sands of New England. After spending the remainder of the time at their disposal in strolling through the quaint streets of this ancient and most interesting town, every part of which is redolent with historic flavor, the visitors resumed their seats in the waiting train for their journey homewards.

On the trip to Boston, which was started at about 3:10 P. M., the train stopped at all the stations, where, as on the trip down in the forenoon, there were assembled crowds of enthusiastic people, who repeated their demonstrations with the added accompaniments of lanterns, fireworks and bonfires. The train reached South Boston at about 6 P. M. without experiencing the least mishap to mar the pleasure of the first trip over the new Old Colony Railroad, which Mr. Nathan Hale, of the Boston *Advertiser*, one of the speakers of the day, fittingly termed "A Band of Union Between the Rock of Plymouth and the Cradle of Liberty."

In the early days of the "horseless carriage," its cousinship with the bicycle was well identified by the steel tubing used for the frame, the wheels with tangent spokes and pneumatic tires and the chain and sprocket drive. The evolution of the airship from the automobile seems to be established by the flying machine of Sergius Vuite as a combination with the aeroplane.

\*[This article, which is complete in itself, forms so interesting an account of the opening ceremonies of the Old Colony Railroad in 1845, that it is printed as received from Mr. W. A. Hazelboom, of Boston, Mass. It is one of the many interesting reminiscences of early railroad days which have been sent to Angus Sinclair for use in his book on the "Development of the Locomotive Engine."—Ed.]

### All Steel Coach for the Erie.

The Erie Railroad have lately received an all steel passenger coach, and it has attracted much attention at the terminal, where it stood for a few days. The car is practically non-wreckable and will not burn. There is less than 300 lbs. of wood or other inflammable material used in its construction, and all of that has been treated with a preparation which, it is claimed, renders it immune to any ordinary degree of heat.

The car looks like the standard pas-



ALL STEEL PASSENGER CAR FOR THE ERIE RAILROAD.

senger coach in general use, and the ordinary observer would not notice any difference. It is somewhat shorter in length than the usual Erie coach, being but 52 ft. in length, but its weight is much in excess of the wooden car, being nearly 100,000 lbs. A 75-foot modern Pullman with berths and other interior fittings averages 120,000 lbs., ready for service.

The body and truck construction of the Erie car is entirely of steel, as is the floor, which is made of  $\frac{1}{8}$ -in. steel plates covered by a non-combustible composition. The Pullman type of wide vestibule has been used, the window sashes are of metal and open automatically; there are continuous baggage racks and the lighting is from Pintsch gas mantle burners. The car is equipped with the Westinghouse high speed brake.

The doors in either end are of wood, and the seats are covered with plush, but the designers claim that, neither will burn. The car is so strongly built and so well riveted that it is said it will stand almost any shock that railroad service will give it. Its weight is the only bad point, from an operating view, but it is expected that the designers will profit by experience and produce a steel coach of equal strength but of lighter weight.

The Erie Railroad have been one of the pioneers in steel cars, having had in service for two years or more, several all steel baggage and postal cars, which are giving excellent satisfaction. The cost of steel coaches, at present, is

much above that of wooden cars, due largely to experimental construction, but builders feel that this can be greatly reduced when cars are built in large numbers. The Erie coach will be used in through passenger service for the present. It will hold sixty-one passengers.

### Westinghouse Activities.

Most of the Westinghouse Companies are now making considerable additions to their works in order to increase their manufacturing facilities so

roads are making, at present, greater demands for brake and draft gear equipment than ever. The Air Brake Company have now about 4,000 employes at work, a larger number than they ever had. The existing shops have already proved inadequate. The company have now in course of erection a core shop 85x140 ft., a pattern shop and store room 80x330 ft., and they are about to begin the erection of a new carpenter shop 45x120 ft. The works of this company have never been busier than at present, the output has never been larger and the outlook for future business has never been brighter.

The Union Switch & Signal Company of Swissvale, Pa., have several hundred men at work on the site recently acquired by them for the erection of additional shops, which the company require in order to meet the enormous growth of their business. At the present time every department at the factory is working to its fullest capacity and with the amount of orders already on hand, the management is looking eagerly forward to the completion of the new works. The grading of the site for this building has been completed, the foundations are now fairly under way, and it is expected that work on the steel structural part will be commenced within the near future. This company has an unusual amount of routine orders on hand apart from the special

as to meet the constantly increasing demands for their products.

The new eight-story steel structure which is being erected by the Westinghouse Electric Company is being pushed with the utmost vigor. This will give an



INTERIOR OF ERIE STEEL COACH.

addition of 250,000 sq. ft. of floor space, to be utilized for the construction of details and supplies.

Judging by the improvements and enlargements now under way at the works of The Westinghouse Air Brake Company at Wilmerding, Pa., the rail-

work for the contract from the Pennsylvania Railroad on the New York and Long Island terminal equipment.

Never be idle; if your hands cannot be usefully employed, attend to the cultivation of your mind.—*Golden Maxims.*

**Well Worth Asking For.**

Our illustration shows a very ingenious little device which can be most conveniently carried in the pocket. It is made of celluloid and can easily be kept clean, even though used in the busiest shop in the land. On the side of the disc showing the trade mark of the Cleveland Twist

every month, and also scan our advertising columns and they will see the titles and prices of our books devoted to railroad matters. They are all by leading authors and are revised up to the present year.

Development of the Locomotive Engine, by Angus Sinclair, is a history of the growth of the locomotive from its most elementary form, showing the gradual steps made toward the developed engine, with biographical sketches of the eminent engineers and inventors who nursed it on its way to the perfected form of to-day. Many particulars are also given concerning railroad development. Published by the Angus Sinclair Publishing Co., 136 Liberty street, New York. 680 pages, profusely illustrated, and bound in half morocco. Safety devices, especially the Air Brake and Safety Valve, are treated in a clear and comprehensive manner. Beginning with the earliest attempts at harnessing steam, the narrative unfolds itself with the interesting grace of a romance. The entrancing story is epic in the greatness of events. Price \$5.00.

"Standard Train Rules." This is the code of train rules prepared by the American Railway Association for the operating of all trains on single or double track. Used by nearly all railroads. Study of this book would prevent many collisions. Price 50 cents.

"Mechanical Engineers' Pocketbook," Kent. This book contains 1,100 pages, 5x3¼ ins., of closely printed minion type, containing mechanical engineering matter. It ought to be in the bookcase of every engineer who takes an interest in



DECIMAL EQUIVALENTS.

Drill Company, of Cleveland, Ohio, it is arranged so that the decimal equivalents of the inch, from one sixty-fourth up, can be found by an almost instantaneous adjustment of the little revolving disc. This is a most useful and valuable feature and is the quickest thing we have seen anywhere for the purpose. The other side, as medal experts would say, is arranged so that the slide disc when set opposite the size of any drill will at once give the number of revolutions per minute at which the drill can be revolved. There are two sets of figures, one for high-speed steel and one for carbon steel. The adjustment is as rapid as it can be, and the answer is definite and sure. If you want one of these "feed and speed" computers write to the Twist Drill Co. and you will get a good thing and a handy thing. In fact, to use the words of the proverbial traveling showman, the ease with which you can get the decimal equivalent of an inch by this computer "is alone worth the price of admission," but this computer is free for the asking and is well worth having.

**In the Woods.**

"An impulse from a vernal wood  
May teach us more of man,  
Of moral evil and of good  
Than all the sages can."

When the poet Wordsworth wrote these lines he had been in the woods a long time, and had learned a great deal. We are not all poets and it is not really necessary for all of us to take to the tall timber to learn something. Those who are desirous of learning all about the mechanical appliances used on railways should carefully peruse the pages of RAILWAY AND LOCOMOTIVE ENGINEERING



DRILL FEED AND SPEED COMPUTER.

engineering questions. We use it constantly as a reference for questions sent to us to be answered. Full of tables and illustrations. Morocco leather, \$5.00.

"Locomotive, Simple, Compound and Electric." Regan. An excellent book for people interested in any kind of locomotive. It will be found particularly useful to men handling or repairing compound locomotives. It is the real locomotive up to date. \$2.50.

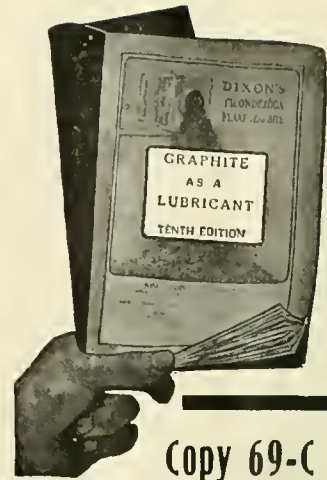

**Copy 69-C FREE**

Here is a complete and interesting story of graphite and its development as a lubricant. You can not get in any other book of equal size so much information of REAL value. The experience of practical men and the experiments of scientific authorities are both given in this TENTH EDITION of

**"Graphite as a Lubricant"**

making it valuable to men of practice and students of theory.

Lubrication in almost every kind of machinery is treated of. "Kinks" and "short-cut" methods discovered and used by resourceful engineers are included.

You should get this book now. Write for FREE copy 69-C.

**JOSEPH DIXON  
CRUCIBLE CO.  
Jersey City, N. J.**

# GOLD Car Heating and Lighting Co.

Manufacturers of

**ELECTRIC,  
STEAM AND  
HOT WATER  
APPARATUS  
FOR RAILWAY CARS**

**EDISON  
STORAGE  
BATTERY  
FOR RAILWAY CAR  
LIGHTING**

**Largest Manufacturers in the World  
of Car Heating Apparatus**

**Catalogues and Circulars  
cheerfully furnished**

**Main Office, Whitehall Building  
17 BATTERY PLACE  
NEW YORK**

"Simple Lessons in Drawing for the Shop," by O. H. Reynolds. This book was prepared for people trying to acquire the art of mechanical drawing without a teacher. The book takes the place of a teacher, and has helped many young men to move from the shop to the drawing office. 50 cents.

"Locomotive Running Repairs," by L. C. Hitchcock. The book contains directions given to machinists by the foreman of a railroad repair shop. It tells how to set valves, set up shoes and wedges, fit guides, care for piston packing, and, in fact, perform all kinds of work that need a thoughtful head and skilful hands. 50 cents.

"Care and Management of Locomotive Boilers," Raps. This is a book that ought to be in the hands of every person who is in any way interested in keeping boilers in safe working order. Written by a foreman boilermaker. Also contains several chapters on oil-burning locomotives. 50 cents.

"Machine Shop Arithmetic," Colvin

Railroad. Previous to reporting for duty at the roundhouse Engineer James Burd, who hauls the Buffalo flier leaving Harrisburg at 11 10 P. M., dreamed that his train had run into a landslide at a point between Dauphin and Halifax, fifteen miles from here. He told his dream to several roundhouse attaches, but they laughed at him. Engineer Burd, to ease his mind, determined to run slowly after passing Dauphin. At a point some distance north of Dauphin, identical with the place he had seen in his dream, the engine plowed into a landslide. Going slowly the engineer was able to bring his train to a stop with little or no damage."

### Camden & Amboy Monster.

The Development of the Locomotive Engine by Mr. Angus Sinclair is meeting with a most gratifying success. In our September paper we made a short extract from one of the chapters on Curiosities of Locomotive Design in

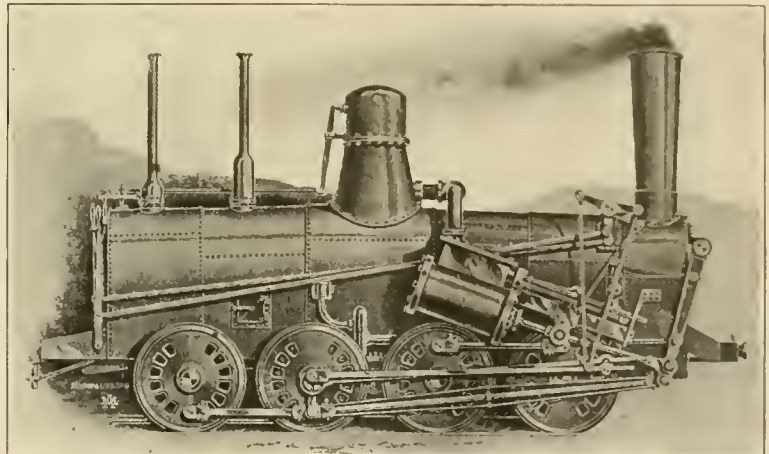

FIG. 8. CAMDEN & AMBOY MONSTER.

and Cheney. This is a book that no person engaged in mechanical occupations can afford to do without. Enables any workman to figure out all the shop and machine problems which are so puzzling for want of a little knowledge. We sell it for 50 cents.

"Firing Locomotives," Sinclair. Treats in an easy way the principles of combustion. While treating on the chemistry of heat and combustion, it is easily understood by every intelligent fireman. The price is 50 cents.

### Dream Averts a Train Wreck.

The columns of RAILWAY AND LOCOMOTIVE ENGINEERING have repeatedly contained accounts of dreams giving engineers warning that prevented accidents. Another case of that kind is reported in press dispatches from Harrisburg, Pa. The dispatch reads: "Confidence in a dream probably averted a big wreck on the Northern Central

which the author gives an array of what we would now call freaks. Some of these engines were freaks pure and simple, while others were honest endeavors to realize more or less satisfactory forms of construction which, however, the test of time did not permit to survive.

One of the engines referred to was the "Camden & Amboy Monster," Fig. 8. It so happened that a line engraving of the Mason double-truck locomotive appeared on page 400 of our September paper, bearing the reference number belonging to the "Monster." For the benefit of our readers we here reproduce a half-tone illustration of the real "Camden & Amboy Monster" as it appeared in all its native grace of outline.

Speaking of this engine Mr. Sinclair says:

"Locomotives driven through a supplementary driving axle were very common in the United States, but they were

used mostly in the process of evolution. All the Baltimore & Ohio grasshopper engines were driven in this way and they worked quite satisfactorily. The Camden & Amboy monster, shown in Fig. 8, had heavy spur gears on the axles of the middle pairs of wheels, which engaged with an intermediate gear performing part of the work done by coupling rods."

#### New Hollow Chisel Mortiser.

The machine which is shown in our engraving is a new Automatic Hollow Chisel Mortiser. It is a medium sized machine, designed for use in car shops, furniture, carriage, wagon, sash, door and blind factories. The capacity of the machine is 8 ins. wide by 8 ins. thick, and it will mortise from  $\frac{1}{2}$  in. to 1 in. square and to a depth of 7 ins.

The bits are fixed to a reciprocating frame moving in planed sides on the top of the column. The depth of the mortise is regulated either by the adjustment of the table or the adjustment of the stroke. The chisel is driven by elliptic gears, which give it a quick return at the completion of the mortise. The foot treadle at the base of the machine governs the chisel thrust. The stroke is made variable by changing the position of the crank pin on the crank arm.

The table is 40 x  $8\frac{1}{2}$  ins. It is counterbalanced and has a vertical adjust-

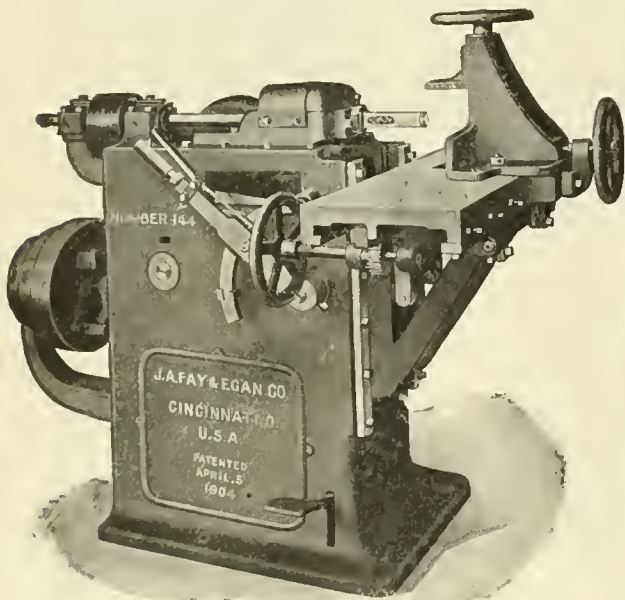

HOLLOW CHISEL MORTISING MACHINE.

ment of 6 ins., which is secured by the movement of a lever provided with steps, by which one or more mortises can be made as in double mortising. It has also endwise an adjustment for regulating the length of the mortise. This is done by a hand wheel, operating a rack and pinion.

The manufacturers of this machine are the J. A. Fay & Egan Co., of Cincinnati,

O. They will be happy to furnish full information about this or any other of their large assortment of wood-working machinery.

#### Triple Ring and Slide Valve Grinder.

A very useful railroad shop tool is in use in one of our leading railways with headquarters not far from New York. It is a triple valve ring and slide valve grinder. This machine shown in our illustration has been designed by the general foreman of the shop and can be run by belt, compressed air or electricity.

Mr. G. W. Curran, who worked out the details and has put the machine to the practical test of actual service, claims that triple valve bodies can be applied and the rings ground in from 3 to 5 minutes. The slide valve of the triple is ground on its own seat, special spindles being provided for the "Westinghouse" and the "New York" triple slide valves. In

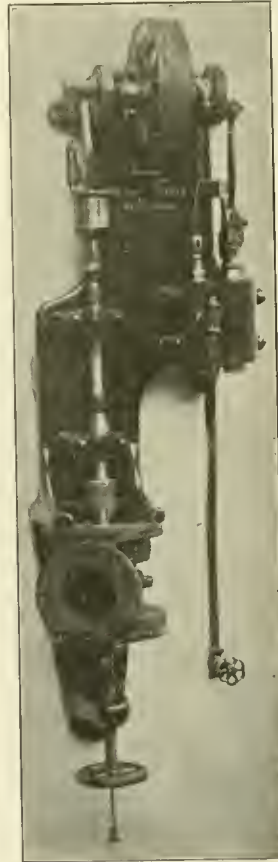

TRIPLE VALVE RING AND SLIDE VALVE GRINDING MACHINE.

grinding rings, which is a very important operation, the spindle revolves to insure perfect abrasion of the bushing and by pushing a button a perpendicular motion only remains, as used in grinding the slide valve. The length of the stroke is adjustable to meet all requirements. The motion is governed by using a heavy pulley acting as a fly wheel.

It has been found that from 400 to 500 revolutions per minute give the best results. The bearings are of bronze,

## The Best Railroad Books

### Air Brake Catechism

By Robert H. Blackall. The new revised, 1907 edition, is right up to date and covers fully and in detail the Schedule E. T. Locomotive Brake Equipment, 11-3 Brake Valve, SF Brake Valve (Independent), SF Governor Distributor Valve, B-4 Feed Valve, B-3 Reducing Valve, Safety Valve, K Triple Valve (Quick-Service) Compound Pump. It is the Standard Book on the Air Brake. Contains over 2,000 Questions and Answers on the Old Standard and Improved Equipment. Price, \$2.00.

### The Walschaert Locomotive Valve Gear

By W. W. Wood. If you would thoroughly understand the Walschaert Locomotive Valve Gear, you should possess a copy of this book, as the author explains and analyzes it in a most practical manner. Price, \$1.50.

### Locomotive Breakdowns

By Geo. L. Fowler. Tells how and what to do in case of an accident or breakdown on the road; includes special chapters on Compound Locomotives. Better procure a copy, as it contains 800 Questions with their Answers. Price, \$1.50.

### New York Air Brake Catechism

By Robert Blackall. The only complete treatise on the New York Air Brake and Air Signaling Apparatus. 250 pages. Price, \$1.00.

### Combustion of Coal and the Prevention of Smoke

By Wm. M. Barr. Contains over 800 Questions and their Answers on How to Make Steam. Price, \$1.50.

### Link Motions, Valves and Valve Setting

By Fred H. Colvin. Shows the different valve gears in use, how they work and why. Piston and slide valves of different types are illustrated and explained. A book that every railroad man in the motive power department ought to have. Price, 50c.

### Train Rules and Dispatching

By H. A. Dalby. Contains the standard code for both single and double track and explains how trains are handled under all conditions. Gives all signals in colors, is illustrated wherever necessary, and the most complete book in print on this important subject. Flexible leather binding. 221 pages. Price, \$1.50.

### The Railroad Pocketbook

By Fred H. Colvin. Gives clear and concise information on just the points you are interested in. It's really a pocket encyclopedia, fully illustrated, and so arranged that you can find just what you want in a second. 250 pages. Price, \$1.00.

## CHARTS

### Air Brake Charts

By Blackall. Shows passenger and freight equipment. Printed in ten colors. Price, 50c.

### Anatomy of a Freight Car Chart

(Box Car.) Has every part numbered and named. Price, 25c.

### Anatomy of a Freight Car Chart

(Gondola Car.) Has every part numbered and named. Price, 25c.

### Traction Power Chart

Shows the draw bar pull of any locomotive without a single calculation. Price, 50c.

### Anatomy of a Passenger Car Chart

Has every part numbered and named. Price, 25c.

Send for a special circular describing these books in full. Any of these books sent prepaid on receipt of price.

### AGENTS WANTED

Write for particulars.

The Norman W. Henley Publishing Co.  
132 Nassau St., New York, U. S. A.

# The Superiority OF RUBEROID ROOFING

Registered U. S. Pat. Off.

For railroad uses is no better demonstrated than by the following letter:

"We have gotten better results from Ruberoid Roofing than any other roofing of this style which we have tried. In fact, where we must contend with coal smoke, we have decided that we cannot afford to use any other kind of composition roofing. B. S. WATHEN, Chief Engineer, "The Texas Pacific Railway Co."

Send for Prices and Samples.

**THE STANDARD PAINT COMPANY**  
100 William St., New York  
CHICAGO, ST. LOUIS, PHILADELPHIA, ATLANTA, BOSTON, KANSAS CITY, NEW ORLEANS.

# Ball's Official R.R. Standard Watches

16 AND 18 SIZE

17 and 21 Ruby  
Jewels,  
Sapphire Pellets

Ball's Improved  
Safety  
Double Roller



Are without question the finest watches that American talent and skilled labor can produce, and they are giving such universal satisfaction that we have no hesitancy in claiming that they are the best and safest railroad watch on the market.

Tests severe and numerous have proven this fact to the most critical users in all sections of the country, to which thousands of good Railroad and Brotherhood men are ready to certify.

We have an authorized agent in nearly every railroad center. Call on him for information and facts. Write us for descriptive matter.

**The Webb C. Ball Watch Co.**  
Watch Manufacturers  
Ball Building, Cleveland, Ohio, U. S. A.

# Patents.

GEO. P. WHITTLESEY

MCGILL BUILDING WASHINGTON, D. C.  
Terms Reasonable Pamphlet sent

and are made long so as to ensure substantial service and they are easily adjusted in case of wear. The machine has a solid cast frame and can be attached to a wall or post so that no floor space is required. Altogether it is a handy shop tool.

### A New Refractory Material.

A new refractory material for use in pyrometer tubes, pipes, muffles, plates, crucibles, etc., is being introduced in this country. This material, which is known as Electroquartz, is composed of fused silica, a pure silica product of the electric furnace. It is stated to have all the properties of the quartz product made from rock crystal except transparency. The maker states the material possesses a low coefficient of expansion, thereby permitting it to undergo violent temperature changes without cracking. It will withstand a temperature up to 1,400 degrees centigrade (2,552 degrees Fahrenheit), at which temperature it softens. The melting point is 1,600 degrees centigrade.

It seems to us that this Electroquartz would make an improved material for making brick arches for locomotive fire boxes, if it could be made cheaply enough.

In accordance with the recent action of the American Railway Association and the Master Car Builders' Association, the Pennsylvania Railroad Company have notified their agents that the placing of advertisements on freight cars of railroad ownership will be prohibited. Agents have been instructed to advise shippers, and in case advertisements are applied to cars in the possession of shippers they must be removed before the cars are forwarded over the lines of the railroad. All advertisements found on cars must be removed by the railroad on whose lines the cars are. Advertisements found on cars received from connecting lines will be removed and the delivering line billed a stated charge for their removal.

The Baldwin Catalogue, Record No. 63, has a beautiful frontispiece illustration showing a view of the exhibit of the Baldwin Locomotive Works at the Jamestown Exposition. The setting of the exhibits in a cool and finely wooded grove is a novelty in itself and has been greatly appreciated during the warm summer months by the visitors. The catalogue fully maintains the usual high standard of excellence and shows several good examples of consolidation locomotives furnished with the Walschaerts valve gear for the Chicago and Eastern Illinois Railroad. These fine engines approach 190

tons in weight and are the heaviest in use in Eastern Illinois. They are built in three varieties, including six coupled, eight coupled, and ten wheeled engines. An elegant model of the Pacific type built for the Central of Georgia Railway is shown, and also several models of the consolidation type for the same company. The heaviest engine shown is that of a special order for the Rock Island, where the weight of the consolidation engine and tender exceeds 200 tons. They are also furnished with the Walschaerts valve gear, which seems to be rapidly growing in favor on the heavier class of engines. A copy of this catalogue can be had by direct application to the builders.

The Crandall Packing Company, of New York, have issued a trade circular, No. 4, describing and illustrating their various designs of packing for steam pressure, gas and ammonia service. The quality of the company's work is the best, and their special new designs of reinforced spiral packing meet the increasing need for packing that will suit any size of rod or packing box. The flat and tubular gaskets and sheet packing are also fully described with accompanying price lists. The pamphlet should be in the hands of all who are interested in high class packing at economical prices.

### The Wallace Smoke Stack.

The smoke stack illustrated in our line engravings represents one of those minor railroad inventions that embrace great possibilities of money saving when they are properly used. In the instructions issued to engineers and firemen most railroad companies emphasize the necessity for preventing waste of steam through the safety valves, especially at stations, but all the same the exhaust from the air pump being invariably passed through the smoke stack keeps fanning the fire until it is impracticable to prevent blowing off. The waste of steam through the fire being stimulated by the air pump exhaust must be very great, and it is surprising that so little has been done to stop the vicious practice. In Europe it is a regular thing to provide a separate pipe for the air pump exhaust. This practice has the objection that it adds an extra part.

In the smoke stack shown, a supplementary passage in the smoke stack casting is provided for carrying away the air pump exhaust in a manner that cannot interfere with the fire. The arrangement is neat and effective. It would handsomely pay every railroad in the country to scrap the smoke stacks they are using, that this Wallace stack might be substituted. The stack is the invention of William G. Wallace, S. M.

# What Will YOU Do at 50?

Have you ever thought what will become of you when your earning capacity is waning?

At 50, will you still be working for a low wage or enjoying a good income?

That all depends upon what you are doing **NOW** to secure the knowledge and training that will steadily advance you in position and earnings during the coming years. It is only by fitting yourself with the qualifications that will enable you to accept every opportunity for advancement that you can enjoy a good income when fifty years old and can secure a happy, self-dependent old age.

The most practical, easiest, cheapest, and surest way in the world to secure this necessary training is through the salary raising training of the **INTERNATIONAL CORRESPONDENCE SCHOOLS**—a six-million dollar institution whose sole business for 16 years has been to provide men and women with the training needed to qualify them for higher positions. No matter where you live, no matter what your circumstances are, no matter how old or how young you may be, the I. C. S. can adapt its plan to your personal needs and circumstances. You owe it to yourself and to those dependent on you to investigate this plan. **Do it now** by sending in this coupon. **Read it.**

**International Correspondence Schools**  
Box 805, Scranton, Pa.

Please explain, without further obligation on my part, how I can qualify for a larger salary and advancement to the position before which I have marked X

General Foreman	R. R. Const'n Eng.
R. R. Shop Foreman	Civil Engineer
R. R. Trav. Engineer	Bridge Engineer
R. R. Trav. Fireman	Chemist
Locomotive Engineer	Mining Engineer
Air-Brake Instructor	Architect
Air-Brake Inspector	Bookkeeper
Air-Brake Repairman	Stenographer
Mechanical Engineer	Ad. Writer
Mechanics Craftman	French } With
Machine Designer	German } Edison
Electrical Engineer	Spanish } Phonograph

Name \_\_\_\_\_

Employed by \_\_\_\_\_ R. R.

Street and No. \_\_\_\_\_

City \_\_\_\_\_ State \_\_\_\_\_

P., of the Detroit, Toledo & Ironton Railway, and is patented. Parties wishing to use the stack should apply to Mr. Wallace for terms. With a strong company to back it this stack would very soon begin the steam saving that its use would certainly affect.

Many railroad companies are going to

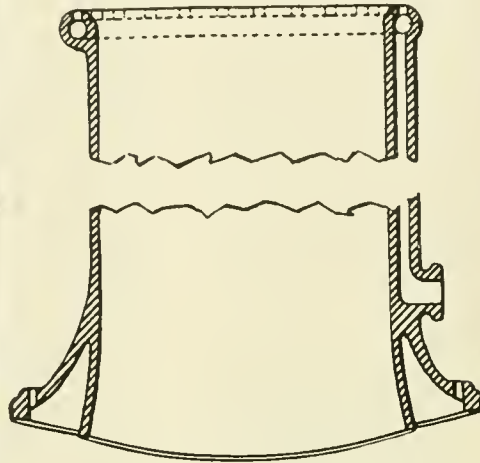

THE WALLACE SMOKE STACK.

great expense and incurring no end of trouble to introduce superheaters and other appliances calculated to save steam; and they keep wasting it through safety valves because the air brake exhaust steam is constantly stimulating

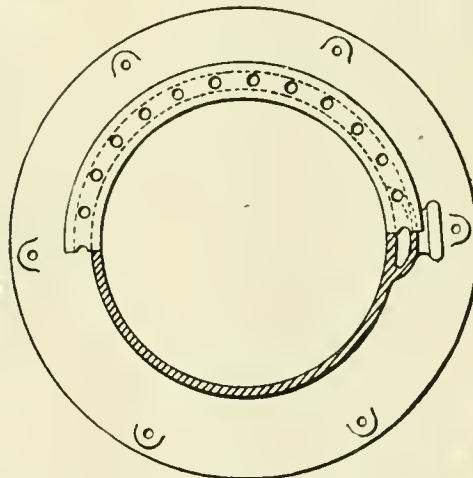

PLAN OF WALLACE STACK.

the generation of steam at times when no care should be spared to keep it down. We make a stand in favor of this small improvement that will produce important savings.

**Brake Shoe Tests.**

We have received a communication from Mr. F. W. Sargent, chief engineer of the American Brake Shoe & Foundry Co., of Mahwah, N. J., in which he says: "The very interesting table and diagrams presented in the report of the Standing Committee on Brake Shoe Tests of the M. C. B. Association at their recent meeting, while clear to many of those who have followed closely the work

# Tate Flexible Staybolt



Strong

Effective

Economical

Flexibility

Durability

Simplicity

Holds firebox sheets securely together, and accommodates itself to the unequal expansion of the plates.

## FLANNERY BOLT COMPANY

PITTSBURG, PA., U. S. A.

Sulte 308, Frick Bldg.

D. E. D. STAFFORD, - - General Manager  
Write us for Reference Book



*Perfect*

Why pay more for a Car and Locomotive Cleaner, when the "PERFECT" will do the work and better at 48 cents per gallon, f. o. b. Philadelphia or Chicago?

THE MODOC SOAP CO.  
228 North Fourth Street  
PHILADELPHIA, PA.

**MICA**  
CABOOSE LAMP CHIMNEYS  
Save 50 per cent.

STORRS MICA CO.,  
R. R. Dept. Owego, N. Y.

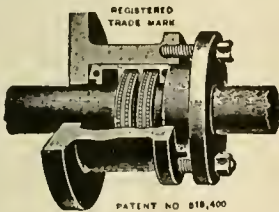

PAT. NO. 488,177	PAT. NO. 554,841
" " 800,848	" " 554,842
" " 834,104	" " 729,848
" " 602,828	" " 775,184
" " 775,148	" " 776,480

**NO MORE BILLS for PACKING**

No Cutting of Rods  
Less Oil. No friction

Guaranteed 3 years. 30 Days' Trial  
No Pay unless Satisfactory  
Beware of Imitations. Use the Best

Manufactured only by

**Holmes Metallic  
Packing Company**

Wilkes-Barre, Pa.  
Send for Catalogue K

**THE WASHBURN CO.**  
Minneapolis, Minn.  
**Automatic Couplers**  
For Freight, Engine and Passenger Service

and reports of the committee, do not, in the opinion of the writer, give sufficient information to enable comparisons to be made between the various shoes tested.

"The table which I submit herewith is part of my discussion on the subject, and is intended to supply some information in detail to supplement the committee's report. I realize the committee's report is in the nature of a preliminary one intended to show what the brake shoe testing machine can do in regard to defining the relative durability and wearing qualities of brake shoes.

"It is important in the study of the question, to take into account not only the surface of insert and hard metal on the face of the shoe, but also the volume of each, realizing that the durability of the brake shoe depends largely on the percentage of hard and tough material in the insert rather than to the surrounding body metal, which may be soft cast iron acting as a holder for the inserts, and that 90 per cent. of the life of the shoe may be comprised within the period necessary to wear out the insert.

"In the case of the records in question, some of the tests were made on shoes in which inserts had been worn through or had fallen out, and of course such records are not true indications of the performance of the original shoe; for that reason this new table has been prepared, which takes into consideration the actual conditions on the face of the shoe during the test. With this clearly understood, the column of comparative durability can be fairly considered."

The table referred to may be had, in blue print form, by those interested, on application to Mr. Sargent.

**Portable Oil Furnace.**

The Railway Materials Company, of Chicago and New York, have placed on the market a new style of portable oil furnace for heating rivets. There has been a great demand for a small oil furnace which was really portable, and the testimonials of those who have used this one confirm the manufacturers in the opinion that the portable features of this furnace alone make it an invaluable addition to any shop where portable furnaces are used. The furnace can readily be wheeled about by one man and instantly attached to the compressed air main, in even the most remote parts of the shop.

The furnace does not require the assistance of an overhead crane to handle it, and in case of necessity it can be run out of doors to the farthest portions of steel car repair yards, where compressed air is available, and it can instantly be made ready for rivet work. The furnace is designed to take up the smallest possible floor space, and can readily find a footing even on such crowded places as the top of a loco-

**Locomotive  
Blow-Off Plug Valves**

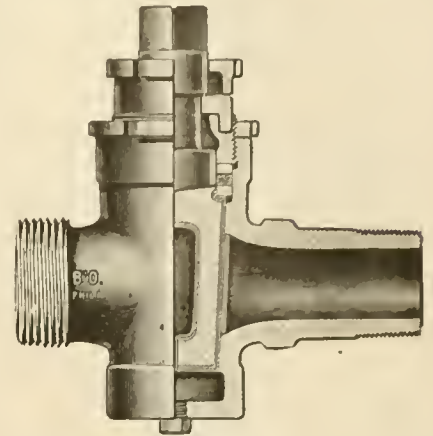

All Brass, extra heavy, with Cased Plug.  
For 250 lbs. pressure.  
Made with Draining Plug to prevent freezing.

**LOCOMOTIVE  
GAUGE  
COCKS**

**For High Pressure**



Bordo Self-Closing Gauge Cocks, made with renewable Hard Bronze seat and disc. Opened and closed with a quarter turn. Guaranteed Steam tight under the most exacting conditions. Shanks Threaded to specifications for Locomotives.

Seats and discs replaced under pressure.

**Swing-Joints and  
Pipe Attachment**



May be applied between Locomotive and Tender.  
These Swing-Joints are suitable for Steam, Gas, Air, Water or Oil.

Complete Booklet on Application  
**L. J. BORDO CO.**  
PHILADELPHIA, PA.

# Homestead Valves

Straightway, Three-way and Four-way.  
and

# Homestead Locking Cocks

Are Famous World Over

They cost more, but are worth very much more than other makes. You try them and see.



Brass, 1 1/2 in.



Iron Body, Brass Plug, 1 1/2 in.

**HOMESTEAD VALVE MFG. CO**

WORKS:  
HOMESTEAD, PA.      PITTSBURG, PA.

## American Locomotive Sander Company

13th & Willow Sts., Philadelphia, Pa.

Proprietors and Manufacturers

LEACH, SHERRURNE, DEAN, SANDERS  
HOUSTON, "SH" and CURTIS

### THE ROBERT W. HUNT & CO.

Bureau of Inspection, Tests and Consultation,  
1137 THE ROOKERY, CHICAGO.

66 Broadway, New York.  
Park Building, Pittsburg.

31 Norfolk House, London, Eng.

Inspection of Steel Rails, Splice Bars, Railroad Cars, Wheels, Axles, etc. CHEMICAL LABORATORY—Analysis of Ores, Iron, Steel, Oils, Water, etc. PHYSICAL LABORATORY—Test of Metals, Drop and Pulling Test of Couplers, Draw Bars, etc. Efficiency Tests of Boilers, Engines and Locomotives.

motive tender tank, where the rivet boy is accessible to the man inside.

The furnace is mounted on three wheels, one of which is swivelled, thus making it easy to roll about. For what railroad people would call the "long-haul," or for transporting it some distance two handles are provided, and one man can move the furnace about in similar fashion to an ordinary wheelbarrow. The weight of the whole is so distributed that, in the trucking position, no weight is carried by the operator—the device being then balanced on the axle.

The furnace is especially designed for facility in renewing the lining. Standard shapes of brick are used throughout and the width, height and length so arranged that any standard fire brick will fit into place without chipping, thus rendering it unnecessary to carry any special tiles in stock. This feature will appeal to those who have waited for

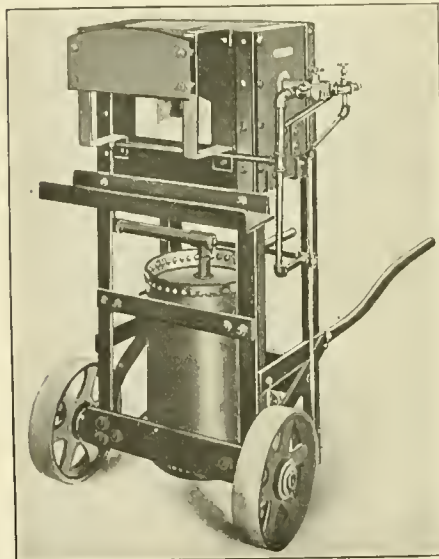

PORTABLE OIL FURNACE.

special shapes to arrive from some outside factory.

Provision is made to protect the operator from the heat, and deflector plates have been placed across the front of the furnace to provide for the comfort of the operator. The door height above the floor is arranged with a view of accessibility. The burner is especially designed for economy in both air and oil, and is so designed that practically no noise results from combustion. This feature of least possible noise has been given careful attention, and this difficulty, so annoyingly characteristic of high pressure burners, has been virtually overcome. With the tank full of oil, one day's supply, the furnace weighs approximately 400 lbs. The furnace is shipped already lined and equipped with all necessary valves and burners—ready for immediate use.

# One Year and Eleven Months' SERVICE

WITHOUT REPACKING, ON

## High-Pressure Locomotives

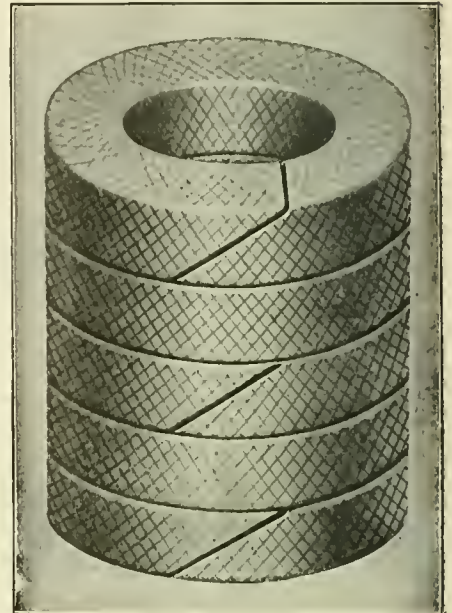

Style 300 TV.

A throttle failure is an absolute impossibility where Crandall's Throttle Valve packing is used.

IT WILL NOT BLOW OUT

## Crandall Packing Co.

FACTORY AND GENERAL OFFICE  
PALMYRA, - - NEW YORK

BRANCHES

New York  
136 Liberty St.

Cleveland  
9 So. Water St.

Chicago  
52 West Washington St.

## Directory of Railways of the World

The Universal Directory of Railway Officials, published in London, contains a list of the entire railroads of the world, with physical particulars and names of all officials.

Send Your Order Now

for the 1907 edition.

Price \$4.00 Prepaid

**A. FENTON WALKER**

Sole Representative for U. S.

148 Liberty St. New York

**THE TANITE CO.**  
**seeks the support of**  
**Railroaders because:**

The man who uses a TANITE wheel will find it safe. Because pay for a TANITE wheel secures the greatest productive capacity. Because TANITE MILLS EMERY is mined in America and appeals to all who earn wages in America. Because TANITE grinding machines are practical.

THE TANITE CO. sells Emery, Solid Emery Wheels, Buffing Lathes, Guide Bar Grinders, Car Brass Grinders, Bench and Column Grinders, Surfacing Machines, Open Side Emery Planers, Saw Gummers, Automatic Planer Knife Grinders, Diamond Tools, Polishing Paste for Brass and Nickel, Emery Wheel Cutters and Dressers.

*The Tanite Co. builds special machines for special wants*

**THE TANITE CO.**  
**STROUDSBURG, PA.**

**THE UNION**  
**SWITCH & SIGNAL**  
**COMPANY**

**CONSULTING**  
**AND MANUFACTURING**  
**SIGNAL ENGINEERS**

**Automatic Block Signals—Electric**  
**and Electro-Pneumatic**

**Interlocking — Electric, Electro-**  
**Pneumatic and Mechanical**

**Electric Train Staff Apparatus**

**General Offices and Works at**  
**SWISSVALE, PA.**

**DISTRICT OFFICES:**

**NEW YORK - - 143 Liberty Street**  
**CHICAGO - - - Monadnock Block**  
**ST. LOUIS - - - Frisco Building**

**Oliver Lippincott**  
**Photographer**

**20 John Street, New York**

**Process and Mechanical Prints**

Perfect reproduction from Tracings, Black Lines, White Paper, any size, for Specifications and Estimates.

The Falls Hollow Staybolt Company, of Cuyahoga Falls, Ohio, have written us as follows, for the benefit of our readers: "Notwithstanding the fire on the 13th inst., which destroyed the greater portion of the building of our rolling mill, the principal machinery was not damaged to any great extent, and we will be able to execute orders with the usual diligence, within a few days."

The energy always displayed by this company in surmounting obstacles will be again proved in dealing with this mishap and business will go on with hardly a perceptible break as far as their many customers are concerned.

Ajax Plastic Bronze is coming into much favor in view of the extensive experiments made by the Ajax Metal Company, of Philadelphia, with a view to ascertain the best alloy of bearing metal for general railway service. The company was the first to discover that the loss of metal by wear, under exactly the same conditions, diminishes with increase of lead, and further that the loss of metal by wear diminishes with diminution of tin. Their experiments were carried on under the auspices of some of the leading railways and it is now believed that the large admixture of lead used, gives an element of plasticity and durability to their bronze bearings which is highly appreciated. A decision has recently been rendered by the Circuit Court of the District of New Jersey protecting this company's plastic bronze patents.

Graphite is not only one of the best of lubricants, but the publication bearing that name and issued monthly by the Joseph Dixon Crucible Co., of Jersey City, N. J., and is one of the breeziest trade publications which we get. Flashes of wit illumine its pages, and it looks as if some of the famous graphite was mixed with the editorial ink, so smoothly do the melodious sentences flow on the polished pages. A finely written biographical sketch of Vice-President George T. Smith is a prominent feature in the September number. Copies may be had on application, addressed to the company's office.

The finely illustrated catalogues that follow each other in rapid succession from the office of the Watson-Stillman Company, New York, are perhaps the best illustration that could be given of the many methods to which their special hydraulic machinery has become adapted. The endless variety of pumps manufactured by the company from the smallest single plunger testing pump to the ponderous four plunger geared belt pump fill a handsomely illustrated cata-

**The Twentieth**  
**Century**  
**Master Mechanic**

Won't use Solid Mandrels.

Cost too much, take up too much room and don't give satisfaction.

**Nicholson**  
**Expanding Mandrels**

Take everything from 1 to 7 inch holes. Take up little room—always ready and you can buy four sets for the cost of one of the solid kind.

**Are You Using Them?**

Catalogue tells you more about them.

**W. H. Nicholson & Co.**  
**Wilkesbarre, Pa.**

**STANDARD MECHANICAL BOOKS**  
**FOR ROAD AND SHOP MEN**  
**BY CHAS. McSHANE.**

**The Locomotive Up to Date**

Price, \$2.50

**New York and**  
**Westinghouse Air Brakes**

Price, \$1.50

**One Thousand Pointers for**  
**Machinists and Engineers**

Price, \$1.50

All books bound in fine cloth.

AGENTS WANTED everywhere; write for terms and descriptive circulars. Will be sent prepaid to any address upon receipt of price.

**GRIFFIN & WINTERS**  
**171 La Salle Street, CHICAGO**

# TOOL STEEL

**Die Blocks  
Steel Forgings**

First Prize awarded at the Louisiana Purchase Exposition, at St. Louis, for our TOOL STEEL when placed in competition with the best makes in England and Germany.

Write for Information and Prices.  
Specify McInnes Tool Steel when ordering.

## McINNES STEEL CO.

CORRY, PA.

Agents  
SCHROCK & SQUIRES,  
291 Pearl St., New York.  
ROY MACHINERY CO.,  
Minneapolis, Minn.

logue of over one hundred and forty pages in themselves, while the array of hydraulic forcing presses keeps pace in number and variety with the hydraulic pumps. Catalogue No. 70 gives nearly one hundred illustrations of presses with full descriptions, while Catalogue No. 71 give: a still larger number of illustrations of hydraulic pumps and their accessories with an additional section devoted to gauges, expanders and other tools. These fine catalogues should be in the hands of all who are interested in hydraulic machinery, and may be had on application at the company's office, 25 Dey street, New York.

The Cutler-Hammer Manufacturing Co., of Milwaukee, Wis., have published a finely illustrated catalogue showing their electric controlling devices. The booklet is of pigeon hole size, and should be in the hands of all interested in electric machinery. Crane controllers are fully described, five different types being illustrated. There are connection and dimension diagrams, repair part charts, with full details of weight and prices. A new and improved form of contacts for handling heavy currents is also described. The Bulletin is No. 59 of the series and illustrates the rapid advance that is being made in the details of electric appliances.

A handsome catalogue of sixty-four pages, cream tinted and profusely illustrated, has been published by H. B. Underwood & Co., Philadelphia, Pa., descriptive of their portable tools for railway repair shops. The number and variety of these machines grow with the complex growth of the twentieth century locomotives, and it would be invidious to begin to particularize. It may be said briefly that there is hardly anything conceivable in the shape of repairs on locomotives that some one of these machines does not effectually meet. The variety of boring bars alone would make an extensive exhibition in themselves, and the anti-dust sleeve attachments are something that meets the situation admirably. The locomotive cylinder and dome facing machines are calculated to save much laborious work and are already very popular in the larger railway shops. The fine catalogue should be in the hands of all who are in charge of railway repair shops.

The American Locomotive Company have just issued the tenth of their series of catalogue pamphlets, which illustrates the Prairie or 2-6-2 type locomotive built for various roads. This pamphlet contains half-tone illustrations, and the principal dimensions in tabulated form of fifteen different designs of locomotives of this type, ranging in weights from 136,000 to 245,000 lbs. The usual style of pamphlet adopted by this company is followed, beginning with the description of this class of locomotives and presenting the advantages which it offers for fast freight and passenger service. A copy of the pamphlet can be had on application to the company.

Locomotive Injectors and Boiler Attachments is the title of a finely printed and superbly illustrated catalogue issued by William Sellers & Co., Philadelphia. The various forms of the injector are described, and many convincing proofs are advanced showing the high quality of the Sellers self-acting injector. Those who are familiar with the older class of injectors can recall the maddening experiments often necessary before the injector would take hold. With the Seller's self-acting injector all that is necessary in starting is to pull out the lever. The quantity of water can be regulated by the water valve. It will be noted that while the injector sprang into perfect operation at once, the manipulation of its parts and the variations in methods of attachment have undergone many changes and a perusal of this fine catalogue will well repay all who are interested in boiler attachments. A copy of this publication may be obtained on application to the company.



**TWENTIETH  
CENTURY  
OUTFIT**

BOLT CUTTER  
IN  
OPERATION.

It will cut hose clamp, bolts, or any like substance as fast as an operator can feed them to its jaws. With every outfit goes a special equipment for each operation, viz. mounting new, pulling off old hose, cutting clamp bolts, everything necessary to Air, Signal and Steam Hose.

This outfit will do the work of a dozen men, and costs less than the annual salary of one man.

**BUKER & CARR MFG. CO.** Office 19 Fairview Heights  
ROCHESTER, N. Y., U.S.A.

The H. W. Johns-Manville Co., New York, are having an increased demand for their pipe covering, which is a sure preventative of electrolysis. The corrosion and consequent destruction of underground pipes is more rapid since the use of electricity has become general. The destruction is caused by "ground return" current flowing through any pipes in its path, and its effects are shown in pitting and corroding the pipe, particularly at the point where the current leaves it. The Electroless pipe covering acts as an insulating medium, and being made of indestructible materials is permanently durable. A descriptive pamphlet has just been issued by the company, which may be had on application at the company's office, 100 William St., New York.

### CONTENTS

*Pennsylvania Railroad Special.....	437
Highflow Writing .....	438
*Quebec Bridge Disaster.....	439
*Curiosities of Locomotive Design.....	441
*Floating Palace (S. S. Lusitania).....	450
*Handy Shop Appliances.....	451
Book Notices .....	454
*Traveling Engineers' Convention (Reports, etc.) .....	455
Good Records by Engineers.....	462
*All Steel Coach for the Erie.....	471
*Triple Valve Machine.....	474
*The Wallace Smoke Stack.....	475
*Portable Oil Furnace.....	477
Editorials:	
Traveling Engineers' Convention.....	452
Condition of Railroads.....	453
Adjusting the Exhaust Pipe.....	453
Acquiring Value by Reading.....	453
State Boiler Inspection.....	454
Locomotives:	
*Simple Consolidation for the C. & O.....	441
*Royal Bavarian 4-4-2 Engine.....	449
*Oil Burning Mogul, G. H. & H. R'd.....	468
Departments:	
*General Correspondence .....	445
*Correspondence School .....	457
Questions Answered .....	459
Air Brake Department.....	460
*Patent Office Department.....	463
*Personals .....	469

# Railway and Locomotive Engineering

Copyright by Angus Sinclair Co.—1907

A Practical Journal of Railway Motive Power and Rolling Stock

Vol. XX.

136 Liberty Street, New York, November, 1907

No. 11

## Bombay-Poona Mail.

The reproduced photograph which forms our frontispiece picture, shows the new Bombay-Poona mail train of the Great Indian Peninsula Railway passing one of the picturesque bends in the vicinity of Bombay. At Mum-

and built after the latest Western ideas, has proved a remarkable success.

The cars are without "sunshades"; that is, the overhanging awning so long thought to be inseparable on Indian passenger coaches. Each car has a body 62 ft. long and 10 ft. wide. The

construction of the cars, notably the window and door fixtures.

The train is shown as being hauled by one of Mr. S. J. Sargent's handsome 6-coupled express locomotives built in Glasgow. This locomotive operates over the Bombay section to the foot of



FAST EXPRESS TRAIN IN INDIA, THE BOMBAY-POONA MAIL.

bra, about twenty miles out, the tracks round a very prominent headland which falls abruptly down to the Kalyan river. The cars forming this train are undoubtedly the handsomest running in the public service in India, and the innovation of a vestibuled express with such luxurious furnishings,

roof and sides are "packed" and "lined" with non-conducting material to protect the interiors from the sun's heat. The arrangements comprise open saloons for first, second and third class passengers, as well as private compartments for ladies, families, etc., in each class. There are many novelties in the

the Ghat inclines. Up these the train is taken by two 8-coupled tank engines to Lanorla, and then by a 4-coupled engine to Poona, 119 miles. The cars are marshalled as follows: Next the locomotive, a combination baggage, guard and third class, with private room for native females and a refresh-

ment bar for third class passengers; second, a full third class open saloon; third, a second class, with an open saloon, two private compartments and a cloak room; fourth, a composite

ductor, car attendant, refreshment manager and waiters.

The cars are painted in accordance with the standard style of the road, dark red-brown on the lower parts,

60 passengers, and rifle racks are provided under the benches. Lavatories are included. The doors of the baggage compartments are of the sliding pattern, but in this case the fastenings are outside.



TYPE OF CARRIAGE USED ON THE GREAT INDIAN PENINSULA.

second and first class open saloon, second class and private compartments, first class; fifth, a well-equipped restaurant car, with complete kitchen, pantry, etc.; sixth, a first class parlor car, with smoking room, and open parlor and a ladies' boudoir; seventh and last, a combination baggage post office, guard and third class for Europeans. All seats are of the "turn-over" type, so that all passengers can face the locomotive; those in the first and second classes are numbered and can be reserved.

Electric lighting is used, each car being provided with a dynamo, etc., the total light on the train being equal to over 2,000 c. p. All the first and second compartments and the mail room have electric punkah fans.

A distinct novelty is the provision of cloak rooms for hand baggage in each car. These are intended for storing the miscellaneous collection of small packages which passengers, both European and natives, persist in burdening themselves with on a railway journey in India. The rooms have expanding gates, so that the contents are constantly under the eyes of passengers and conductor.

The train is equipped with the quick acting vacuum brake, and has also the standard British alarm signal operating off the main train pipe. The train weighs, empty, 240 tons, and has seats for 50 first, 95 second and 320 third class passengers, with an additional 32 seats in the restaurant car. Besides this, there is accommodation for a train crew of eight, comprising guards, con-

with cream above, the mouldings being in dark umber, with fine white lines. The facias are lettered boldly in gold, "Great Indian Peninsula," and the end cars carry the inscription "Bombay-Poona Mail."

The train has been built at the Parel



LOCOMOTIVE TURNING STATION ON AN INDIAN RAILWAY.

shops of the company at Bombay from the designs of our friend, Mr. A. Morton Bell, the car superintendent of the road.

We also illustrate separately a combination baggage and third class car built for the same road. The body framing is a Moulmein teak, with panels of steel plate; the dimensions are generally similar to others of the standard build, being 62 ft. long. The seating is arranged longitudinally for

discovery should prove successful it will contribute greatly to the world's economy. In Ireland there are over 3,000,000 acres of bogland, which are at present useless, while in Scotland 2,500,000 acres will be at the inventor's disposal.

Cause and effect, means and ends, seed and fruit cannot be severed. For the effect already blooms in the cause, the end persists in the means, the fruit in the seed.

**Ten-Wheel Engine for the C. & S.**

The Baldwin Locomotive Works have recently built seventeen locomotives for the Colorado & Southern Railway. Two of these engines are of the ten-wheel type, for passenger service, while the others are of the consolidation type, for freight service. Of the freight engines, six have cylinders 22 by 28 ins., while nine are somewhat smaller with cylinders 20 ins. in diameter with same stroke. The details of the three classes are interchangeable as far as the designs will permit. Our illustration represents the ten-wheel passenger locomotive to which the other engines are generally similar.

These ten-wheel locomotives are examples of a type which is still doing excellent work in heavy passenger service. They have a tractive power of 30,340 lbs., and as the weight on the driving-wheels

lbs., and with the adhesive weight as stated above, the weight on the engine truck amounts to 42,200 lbs. The engine truck wheels are 30½ ins. in diameter and have journals 6x10 ins. The weight of engine and tender together is about 340,000 lbs.

The boiler is of the wagon top type, with a narrow firebox which is radially stayed. The mud ring is 5 ins. wide in front and 4½ ins. wide at the sides and back, thus giving wider water legs than are usually found in narrow firebox boilers. The firebox is supported by a substantial steel cross tie in front, also by expansion links at the sides and a buckle plate at the rear. The frames are dropped between the second and third pairs of driving-wheels, thus giving ample room for a deep throat. The firebox itself measures 120¼ ins. long by 39¼ ins.

leading pair of driving wheels. The boiler is straight topped, but the firebox with its fittings is similar to that used on the passenger locomotives which are here described.

The principal dimensions of the ten-wheel passenger engines are given in the tables below:

Boiler—Material, steel; thickness of sheets, 11-16 and ¼ ins.; working pressure, 200 lbs.; fuel, soft coal.  
 Fire Box—Material, steel; depth, front, 78 11-16 ins.; depth, back, 66 11-16 ins.; thickness of sheets, sides, ¾ in.; back, ¾ in.; crown, ¾ in.; tube, ½ in.  
 Tubes—Material, iron; wire gauge, No. 12.  
 Driving Wheels—Journals, main, 10x12 ins.; others, 9x12 ins.  
 Wheel Base—Driving, 15 0 ins.; total engine, 26 2 ins.; total engine and tender, 54 11 ins.  
 Tender—Journals, 5¼x10 ins.

**Very Bad Fix.**

A railway man in Clay Centre, speaking of those long, complicated coupon tickets sold to California tourists, said: "An old



SIMPLE TEN-WHEEL ENGINE FOR THE COLORADO &amp; SOUTHERN.

H. C. Van Buskirk, Supt. Motive Power and Car Dept.

is 145,250 lbs., the factor of adhesion becomes 4.77.

The frames are of cast steel with single wrought iron front rails. All the driving-springs are underhung, and the equalizing beams are provided with safety straps to keep the rigging from falling down in the event of possible breakage. The frame pedestals are of the usual construction with lugs at the bottom, and the pedestal caps are held in place by vertical bolts. These engines are equipped with piston valves, which are driven by the old-fashioned shifting link motion. The gear is direct acting with transmission bars which pass above the leading driving-axle. The rocker boxes are bolted to the guide yoke, and the rocker shafts have both arms pointing downward. The guide bearer is bolted to heavy knees which are cast in one piece with the rocker shaft boxes. The cylinders are 21x28 ins. and the driving wheels are 69 ins. in diameter, all of them are flanged. The weight of the engine in working order is 187,450

wide, which gives a grate area of 32.6 sq. ft., which is about one seventy-fifth of the total heating surface. This surface is in all 2,465 sq. ft. the tubes contributing 2270½ and the firebox 194½ sq. ft. There are 294 two-inch tubes in the boiler each 14 ft. 10 ins. long. The diameter of the first barrel course is 67¾ ins. The taper course is the second, while the dome rests upon the third course on a level with the roof sheet of the firebox.

The tender frame is built of 13-in. steel channels, and the tender trucks are of the arch bar type with cast steel bolsters. The wheels are 33½ ins. in diameter, the tank has a capacity of 8,000 U. S. gallons and the fuel carried is 10 tons of coal.

It may here be remarked that a distinction between the passenger and the C. & S. freight engines to which we have referred lies in the fact that the latter are equipped with balanced slide valves. With this arrangement, the valve motion is preferably made indirect acting, the rocker shafts being placed back of the

Baldwin Locomotive Works, Builders.

lady pulled one of them on a conductor recently transferred from a plug run. 'Am I goin' in the right direction?' she inquired. The conductor took hold of her ticket, uncoiled it, turned it over, upside down, examined the punch marks, read a part of the instructions, and remarked: 'Well, madam, if you don't know any more about it than I do, you're lost.'—*Kansas City Star*.

**Magnetic Hoists.**

It looks as if the air hoists long used so successfully in American machine shops will be rivalled by hoisting magnets which are coming into great favor in British iron works. Castings weighing two or three tons are lifted by electromagnets. Much time is saved in comparison with the use of hooks, slings, and other devices, as the mere throwing of a switch energizes the magnet, and the apparatus is able to hold on without any catching and securing devices.

### Traveling Engineers' Convention.

(Continued from page 467 ante.)

#### BEST METHODS OF ELIMINATING THE SMOKE NUISANCE ON SOFT COAL BURNING ENGINES.

To the Officers and Members of the Traveling Engineers' Association:

Gentlemen:—Your Committee on the "Best Methods of Eliminating the Smoke Nuisance on Soft Coal Burning Engines" respectfully submits the following report:

A circular letter was sent out to all members of the association requesting answers to eight leading questions, and any other information that would throw additional light upon the subject. The circular letter read as follows:

"1. Have you made any definite attempt to reduce the smoke nuisance? If so, what?"

"2. How do you prepare your coal before putting on tender?"

"3. How do you prepare your fire when starting train?"

"4. How are your firemen instructed to fire?"

"5. What grades of coal do you use?"

"6. Have you noticed any difference in the smoke with the different grades of coal?"

"7. Have you ever tried combustion chambers in boilers? If so, with what results?"

"8. Have you ever tried an auxiliary or variable exhaust appliance to mild exhaust when starting train? If so, with what results? In preventing the smoke nuisance what is the effect upon the fire-box, if any?"

"Kindly give me as much information as possible on these questions, or any other information you may have."

It was confidently hoped that a large percentage of those addressed would reply to this letter, as a report of this character gains in value in proportion to the number of intelligent individual statements upon which it is based, results shown and opinions formed under one set of circumstances either confirming or qualifying the opinions formed by demonstrations under different conditions.

Less than thirty replies were received from the circular letter, and this report is therefore necessarily based upon the experience and opinion of something over twenty members of the association, in place of many times that number as it should be.

Your committee wishes to thank those who replied to the circular for the valuable assistance they rendered in compiling this report.

To add to the clearness of this report the questions presented in the circular and the answers thereto will be taken up in order, after which the general conclusions arrived at by your committee will be stated.

Question 1. Have you made any definite

attempt to reduce the smoke nuisance? If so, what?

With very few exceptions, the replies to this question were in the affirmative and in almost every case the statement was made that the first step was to educate the firemen to fire properly, for no matter what the other conditions might be it was impossible to eradicate black smoke without intelligent and faithful work on the part of the firemen and engineers.

In one or two instances the problem was put up to the engine crews entirely, the road holding them responsible for any excess of black smoke, and suspending both fireman and engineer in all cases where black smoke was produced and no good excuse for same could be given.

Smoke inspectors are also employed on certain roads, whose duty it is to instruct firemen and to look into cases where too much black smoke was being thrown off, and, if possible, to find first the cause, and then the remedy.

Mechanical devices are also in use on several roads to assist the fireman in his attempts to fire properly, and almost without exception the devices used are showing good results, so much so that the further experimenting with practical devices for assisting the fireman in his exhausting work seems to be a feature that must receive more thoughtful attention on the part of railroad managements, the modern massive power having made the proper firing almost beyond the physical powers of the fireman, no matter how faithful he may be, unless aided by mechanical means.

The pneumatic fire-box door closer was strongly advocated in two instances, while automatic stokers received the endorsement of two correspondents who claimed they not only relieved the fireman, but spread the coal better and did away with the necessity of opening the door and drawing cold air in over the fire.

The use of the hollow brick arch was also advocated, the claim being made that better combustion resulted from its use, and therefore a diminishing of black smoke, although our correspondent maintained that the good results obtained from brick arches did not compensate the cost of maintaining them in wide fire-boxes.

Smoke consumers, consisting of a strong blower in the front end and steam jets into the fire through the side sheets, also received recommendation, as they were said to give good results if the engine was fired light.

Answers to question No. 2 showed that only a few roads prepare their coal. Those that do get good results, the general method being to break the large pieces into lumps from four to six inches in diameter.

One method which appears practical and inexpensive is to provide coal sheds with breakers made by placing  $\frac{3}{4}$ x3-in. iron bars set on edge about five inches

apart. On these breakers the coal is dumped and must be broken into pieces less than five inches in diameter before it will fall through. The value of such practice should not be overlooked by railway companies.

In answer to question No. 3 almost without exception the same plan is advocated for preparing the fire. The fire is built up gradually until a good level bed of coals is secured of sufficient thickness to hold without tearing under heavy exhaust, and thereafter the use of the single scoop system in replenishing the fire. When stops are made the fire should be in such prime condition that it will not be necessary to put on much green coal when starting train, and the engineer should use every effort to assist the fireman in holding his fire by pulling out carefully, and when the stop is to be a short one the fireman should endeavor to have his fire in such condition that no green coal need be added until the train has left the station.

The blower should be used to pull just enough air through the fire to combine with gases, and grates and ash-pan should be kept clean and in good condition. The condition of grates has much to do with the suppression of black smoke.

In answering question No. 4, all replies indicated that firemen were instructed to fire as lightly as possible, from one to four scoops at a time being advocated. The one-scoop system seems to be in universal favor, but in some instances it is deemed impractical on account of the modern heavy power, large fire-boxes, and the limit of human endurance.

However, "fire as light as possible" seems to be the general watchword, and any device that will make the one-scoop system practicable should be tried out by railroad companies, for in no other way can perfect firing be possible. The coal should be well and evenly scattered, first on one side of the fire-box and well into the corners, and then on the other, in order to retain a bright fire on one side of the fire-box to burn the gases discharged from the green coal applied to the other side. The door should be swung after each shovelful is applied, and for this purpose, in order to relieve the fireman, the pneumatic door closer has its advocates.

The replies to question No. 5 shows that probably the greatest stumbling block in the way of eliminating black smoke is the grade of coal used by the roads and the furnishing of a great many different grades on a single system. The poorest grades of coal seem to be received by most of the roads, and as many as seventeen or eighteen different grades on a single road. Since this is the case, the problem of reducing black smoke is even more troublesome than it should be. A fireman who gets one grade of coal trip after trip so that he can get accustomed



to using it to the best advantage, even if it is of the poorest quality, can get better results than the fireman of equal ability who gets a good grade of coal on one trip and a poor grade on the next.

Only one report indicated satisfactory coal conditions. In this instance 50 per cent. of bituminous and 50 per cent. of anthracite coal was used, and little trouble was experienced from smoke, as it could be regulated by increasing the percentage of anthracite at times when excessive smoke was objectionable.

Question No. 6 is supplementary to question No. 5 and the replies only help prove the disadvantage of having several grades of coal to contend with.

Fine coal is found to produce more smoke than lump, as it ignites more rapidly and the smoke and gases formed have less chance of being burned off. This is also true of the lighter grades as compared with the heavier.

Reports show that it is more difficult to prevent smoke with coking coal than with no coking, and still more difficult with slack coal.

On roads where several grades are in use there is no benefit derived from the use of the best grades except in that they produce steam more satisfactorily, and the better the grade of coal the more carbon it contains and the more smoke it will discharge. This is only true, of course, because the fireman does not get the good coal frequently enough to become accustomed to firing it properly. If the better grades were used exclusively and the firemen became acquainted with the right method of handling it, much less smoke would result and lighter firing would be possible.

Question No. 7 in regard to the use of combustion chambers brought only three replies in the affirmative. In one case combustion chambers were used, but discontinued on account of steam failures and the banking of cinders and fire against the lower flues, causing them to leak. In another case they were said to have given good results in generating steam, but were condemned on account of faulty construction. In another case combustion flues or tubes are being used with good results, but as a rule, little experience has evidently been had in this direction.

Question No. 8, in the matter of auxiliary exhaust devices, also brought out the fact that too little intelligent experimenting had been done with them, which seems strange in face of the fact that such splendid results are being secured by their use in other countries.

One report stated that no noticeable results had been shown, while the other reports from roads where they had been used were very favorable. In two instances the statement was made that considerable experience with auxiliary exhaust devices had demonstrated their

value, not only as smoke reducers, but as coal savers, on account of their equalizing the draft through the fire-box, and thereby making lighter and more systematic firing possible. Faulty construction was the only unfavorable comment in another instance, and this is undoubtedly the reason for the hesitancy most roads show in testing out the value of these devices.

In summarizing this report your committee would earnestly advocate the serious consideration of two things:

First, a campaign to bring about the standardizing of grades of coal furnished for locomotives. That, both in the line of economy and convenience, better grades of coal would be desirable is unquestionable, but if managements cannot be brought to realize the economy of good coal or if it is impossible to obtain it at all times, efforts should be made to insure the furnishing of one particular grade at all times in place of from half a dozen to twenty different varieties. No mechanic on earth could turn out satisfactory work if you changed the style and pattern of his tools daily, and it is just as impossible for the fireman to do himself justice or work for the best interests of his employers if a continual change is being made in the kind of fuel he must use.

Second, a realization of the fact that the present tendency toward still heavier power must necessitate a change in the old methods of handling a locomotive. Mechanical devices to assist the fireman in the duties that now overtax his strength must sooner or later be put in use, both in the interest of economy to the company and in fairness to the engineer. What devices will best accomplish the desired results is still a question, for the reason that the managements of railroads are backward in taking up anything that looks like an additional expense in maintaining power, while the mechanical departments dread the trouble and nuisance of experimenting with new devices. The enginemen themselves are probably as much to blame as any one for blocking changes that are bound to come at no distant date. Any old-timer knows the aversion of the engineman to any new appliance on his engine, and can remember the storm of disapproval that met the invasion of the injector, the lubricator, and the air pump, but these devices stuck because new conditions made them necessary, just as new conditions to-day are making necessary new devices, and the really progressive railroad man will meet the conditions and do all that he can to discover which are the best means of making it possible for the fireman to fire his engine as it should be fired to prevent black smoke, to hold his steam and to waste as little coal as possible.

While the answers received by your committee were not great in quantity they

were high in quality, and would indicate that this report could safely recommend several things.

The preparation of coal before it is put in the tender (the system mentioned in the early part of this report) is being recommended, because the expense of such preparation is light and coal so prepared can be fired more uniformly and will give better results, and the fireman is saved the additional labor of breaking up big lumps.

The single-scoop system of firing with the closing of door after each scoopful is recommended because in this manner all the gases are given a chance to become properly mixed with the air drawn through the grates and to burn off with the least emission of black smoke, and because more water can be evaporated with a given amount of coal and the fire kept in better condition.

The standardizing of the grades of coal used is approved of because the suppression of black smoke and economical firing is impossible when firemen must contend with a continual change in the quality of the coal they must use.

A more conclusive test of the brick arch is desirable because the tests so far made show that gases and smoke given off by the coal are more thoroughly burned in fire-boxes equipped with brick arches, and less black smoke given off.

A wider investigation of the pneumatic fire-box door closer and the mechanical stoker should be made, because the steady increase in the size of power will in all probability necessitate the adoption of some such device in the interests of economy and the firemen.

A conclusive test of the auxiliary exhaust is advisable because, with the modern large power with its high steam pressure and great volume of exhaust, light and economical firing is practically impossible without some method of equalizing the draft through the fire-box and softening the exhaust when working in full stroke and under heavy throttle.

Yours truly,

JNO. LYNCH,

Chairman.

W. H. BRADLEY,

C. L. BROWN,

MARTIN WHELAN,

W. J. TOY,

Committee.

#### DISCUSSION ON SMOKE PREVENTION.

The foregoing report was read by Mr. John Lynch, after which Mr. Martin Whalen read the following notes of discussion:

"There is no branch of railroading where good judgment and intelligence count for more than in the firing of locomotives. There was a time when the fireman fired almost entirely by the stack, and if, after putting in a fresh fire, the black smoke failed to roll out of the

stack, he would conclude there was something wrong with the fire. If the steam pressure began to lag, the old time engineer would gaze up at the stack and remark: 'There is something wrong with your fire, the smoke is not coming out the way it should.' There was no thought of reducing the smoke; in fact, it was considered a necessity.

"This is no longer true, and it is needless to say that light and frequent firing means a considerable saving in fuel, besides reducing the smoke nuisance to a minimum. Angus Sinclair, in his book on Locomotive Firing, tells of observations taken on the Burlington and the Queen & Crescent, where the system of one shoveling prevailed. He gives an illustration of a trip lasting one hour and fifty-five minutes, during which time with poor firing 8,000 lbs. of coal were used. The following day with careful firing over the same territory there were only 4,500 lbs. of coal used, but the fireman fired one or two scoops of coal at a time. A number of trips over the same stretch of track out of Cleveland, which were made with the object of smoke elimination, showed a variation of from 65 to 103 shovels of coal used, where the load hauled was practically the same on each trip, but the engine was fired by different men; and with the men using the smaller amount of coal, there was scarcely any smoke emitted from the stack, while the fellow using the greater amount showed dense black smoke most of the time.

"Various inventions have been brought out from time to time for abating smoke from locomotives. This was one of the advantages claimed for a mechanical stoker, which was given a very extensive test on the road with which I am connected. Another smoke consuming device which I saw tested, consisting of a brick arch and two or three openings on each side of the fire door, through which air is drawn by steam, proved very effective as a smoke consumer, but considerable trouble was encountered owing to a tendency of clinkers to form on the top of the arch being fitted up tight to the flue sheet, thereby destroying efficiency of the boiler to such an extent that the engine was practically dead, after three days and nights of continuous service. I suggested that there be an opening made between the arch and the flue sheet, but was informed that it would kill the smoke consuming feature. I saw the arch removed on this engine, and the clinker was so hard it remained intact, and had to be knocked out with a hammer.

"In the western cities, where soft coal is used exclusively, the complaint against smoke from locomotives is so bitter that railroad officials are doing everything in their power to prevent it. A few years ago, the city of Cleveland passed a prohibition smoke ordinance. Everything was done by the railroads in the way of fol-

lowing up the engine crews, but results were so unsatisfactory that the smoke inspector called a meeting of officials of the roads that ran into the city. This meeting took place in his office and was attended by about thirty officials, from general managers down to road foremen of engines. They were notified that they would have to take some action to abate smoke from locomotives, or the city authorities would take severe action. It was agreed to conduct some experiments, and a committee was appointed to watch the results of these experiments.

"As a result of this meeting several tests were made, the last one with a heavy train of coal up a six-mile grade through the city, with three engines attached. One engine on the head end had no device, two engines pushing with a caboose between them for an observation car. One of these engines used smokeless coal and the other bituminous coal with a smoke preventive device. In the joint test of the two engines working together, one with smokeless coal, and the other equipped with the device above referred



READY FOR THE WRECKING TRAIN.

to, the abatement of smoke was equal. Smoke was emitted at no time more than five seconds from the engine equipped with the device, and the steaming qualities were not affected. It was agreed between the city and the railroads that every switch engine and engines in hill service in the city of Cleveland would be equipped with this device, which consists of two or three openings on each side of the fire door, or on each side of the fire box, with steam jets to force the air in, and a damper in the fire door that is adjustable, also a deflector plate on the inside of the door. When the engine is not working the blower is used in addition to the jets.

"Although this is a simple contrivance, and was used by our company in 1884, there is no question but it is a success. The trouble is to get the engine crews to use it, as they object to it because it makes considerable noise. Although the city smoke inspector is around continuously, we never get a complaint, unless some engine crew has failed to use it or an engine happens to get into switching service that is not equipped. As a proof that the device does good work, the inspector's office shows that during the year

1905 a total of 3,000 observations showed an average of 10 per cent. of smoke, while a total of 3,500 observations in 1906 after the device had been installed showed an average of only 4 per cent. The railroads co-operate with the city inspector. There is no graft or politics connected with it. It is simply a case of eliminating smoke. Whenever the smoke inspector reports a bad case it receives immediate attention, and the engine crew are called on for an explanation. They are first warned, and if it happens again, and it is found that it is the result of carelessness, they are suspended.

"In addition to the city inspector, the roads have special men, who look after it also. All observations taken by the city inspector are sent to the superintendent of the road of which they are taken, and in addition to this there is a monthly bulletin sent out giving each average, and also the general average.

"I have copies of the observations taken, and also the monthly bulletins, and will be pleased to show them to any of the members who are interested."

Mr. G. J. Shreeve (Belt R. R. of Chicago): In regard to the steam jet, on the road that I am with we have been using what is termed the Weston smoke device similar to the jet of steam. Mr. Whelan claims the only objection is the noise. We find that the clinking of the fire is an objection. I would like to ask Mr. Whelan if he ever found trouble in that way.

Mr. Whelan: In answer to the gentleman, I will say yes. It apparently clinkers the fire more than it would if the steamer was not on, but against that is the proposition of getting smokeless combustion, and in spite of what little difference there is with reference to clinking the fire, if that is the only thing I think it is a success.

Mr. F. C. Thayer (Southern): Mr. President, speaking about using a steam jet over the fire in order to eliminate smoke, we find fires on switch engines in Washington become so that after being in service for six years we had three or four or five hours delay on account of using a steam jet, and we had to discontinue the use of it. This was brought out by a committee that was appointed at Washington for the purpose of eliminating smoke in that district about six months ago. I have been associated with that committee during that time and would say that we have tried no devices outside of this steam jet to eliminate smoke, but we eventually resorted to coke, and even with coke we find if we get a

(Continued on page 508.)

Not until you make men self-reliant, intelligent, and fond of struggle—fonder of struggle than of help—not till then have you relieved poverty.—*Phillips Brooks.*

### Curiosities of Locomotive Design.\*

#### JAMES TOLEMAN'S FOUR CYLINDER LOCOMOTIVE.

A most expensive sacrifice to good intentions was the "James Toleman," Fig. 20, another four cylinder locomotive, but decidedly different from the other two.

The James Toleman was exhibited in 1893, at the World's Fair, in Chicago, and it evidently was expected to create something of a sensation in this coun-



FIG. 20. THE "JAMES TOLEMAN," 1892.

try. The engine represented the ideas of an English engineer as to the best form of locomotive for handling heavy fast passenger trains. It was designed by a Mr. Winby, of London, and was built by Hawthorn, Lester & Co., Newcastle, England.

That the engine was radically different from the ordinary locomotive was apparent to the most casual observer; yet there were many novelties about the machine that could be found only after laborious examination. To obtain high speed and great power combined, two pairs of driving wheels, 90 ins. diameter, were employed, and each pair was driven by a pair of separate cylinders, the front drivers being driven by inside cylinders located under the smoke box, and the back drivers by outside cylinders set outside, back of the leading truck. The inside cylinders were 17 x 22 ins., and the outside cylinders 12½ x 24 ins. A striking point about the outside connections was the long piston rod necessary to reach the guides. The most commendable part of this engine was the arrangement that obviated the use of parallel rods. A shifting link motion was used for the inside cylinders and Joy's motion outside.

The boiler was one of the most curious features of this odd locomotive. To obtain as much heating surface as possible while maintaining a fairly low center of gravity, the boiler was made elliptical, narrowed in the middle of the horizontal diameter, so that it

\*From the "Development of the Locomotive Engine," by Angus Sinclair.

could be strengthened by cross braces.

A very serious objection occurred to me when I first examined the engine, which was the complication of parts and the difficulty that would be encountered in effecting repairs. I wrote: "The designer appears to have had no consideration whatever of the fact that repairs would have to be done frequently to a locomotive pulling fast heavy trains. The engine is very handsome and displays admirable workmanship. It has large bearings and strong connections; but we would not like to have the duty of keeping a number of them in working order."

After the exhibition was over the James Toleman was put upon the Chicago, Milwaukee & St. Paul Railroad, to haul ten parlor cars, 82 miles in two hours. It failed very decidedly on that service, both from lack of steam and through breakage of parts.

#### FATE OF THE JAMES TOLEMAN.

Replying to a letter of inquiry which I sent, Mr. A. E. Manchester, superintendent of motive power of the Chicago, Milwaukee & St. Paul Railway, wrote:

"The engine 'James Toleman' was some seven years ago turned over to the Purdue University, La Fayette, Ind., as a museum feature, and I believe is still there.

"As to the performance of the engine on our road will say that we never got any practical results from it at all.

the end of the flue sheet and the back end of the fire box.

"The engine, as you no doubt remember, had four cylinders. The inside cylinders connected with a crank shaft to the front driving axle and was operated by a shifting link motion. The back cylinders were connected by a wrist pin to the back driving wheels and axles and were operated by a Joy valve motion. All of the cylinders drew their steam from one niggerhead and dry pipe, and the result of this was that whichever pair of cylinders, either inside or outside, took steam first, there was not enough went into the other cylinders to blow into the cylinder cocks, and it was only with a light throttle and moving slowly that all cylinders could be made to take steam at once. When but two of the cylinders were getting all the steam, the tractive power on that pair of wheels was not enough to take care of the work that the cylinders would develop, consequently the engine would stand and one pair of wheels would spin like a circular saw and the others would be doing nothing.

"Mr. Winby, who was the designer and owner of the engine, stayed with it, and had his mechanical engineer and a special engineer whom he brought from England with him for something like two months, until he became thoroughly disgusted and went off and left it. We have not had a word from him for a number of years. I think he has forgotten that he ever designed or owned the 'James Toleman.'"

#### FRENCH FAVOR NOVELTIES.

France has given to the world a fair share of the freaks designed to send the ordinary forms of locomotives prematurely to the scrapheap, and, incidentally, to demonstrate what amateur designers could do in wandering away from well trodden paths of engineering rectitude.

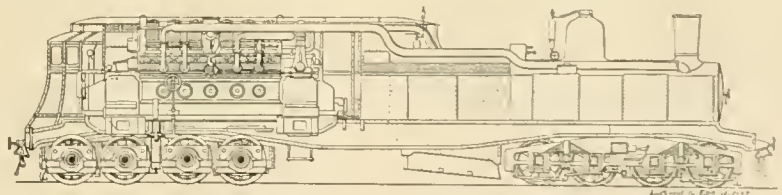

FIG. 21. HEILMANN ELECTRIC LOCOMOTIVE.

"In the first place the grate surface and the size of the fire box were not equal to the demands on the boiler, and no adjustment of the front end or exhaust appliances was equal to taking care of the demands on the boilers.

"You will remember that one of the features of this engine was that the flue sheet extended into the fire box. In other words, it was a combustion chamber reversed, and it was found in practice that all of the grate surface under this projecting portion of the cylinder part of the boiler would not burn the coal, consequently the grate surface was cut down to the limited amount that was between

Gallic sentiment leans kindly to things that look new.

"The earth was made so various that the mind

Of desultory man, studious of change,  
And pleased with novelty might be indulged."

#### HEILMANN ELECTRIC LOCOMOTIVE.

The Western Railway of France experimented persistently in 1897 with electric locomotives, Fig. 21, which generated the electricity in driving it. This form of engine was invented by J. J. Heilmann, a Swiss engineer, residing in Paris. The first locomotive of that type tried was considered to work so satisfactory that

two others, much more powerful than the first one, were made, one of them being the subject of illustration which was copied from the *Railway World*, of London. The body of the engine consisted of heavy steel girders which was carried by two eight wheel trucks. Above the rear part on the deck built upon the frames were placed the boiler and coal bunkers, while the principal steam engine, the two generation electric dynamos, the exciter with a special engine and the airbrake apparatus were carried above the leading truck.

The boiler was of the locomotive Bel-paire type, and provided 1,996.5 sq. ft. of heating surface. The grate area was 35.95 sq. ft. The boiler pressure carried was about 200 lbs. to the sq. in.

The engine was compound with six cranks set in a form that was reported to give perfect equilibrium. The engine drove two electric generators continuous current machines, independently excited. The current supplied by the generators was said to develop 125 horse power at 62 miles an hour. It was calculated that this locomotive would haul a train weighing 250 tons at the speed of 62 miles an hour, which seemed to me a small performance for the expense involved.

The Heilmann locomotive formed a spectacle to the people of Paris for only a few short months.

#### THUILE LOCOMOTIVE.

Another expensive French novelty was the Thuile high-speed locomotive, ex-

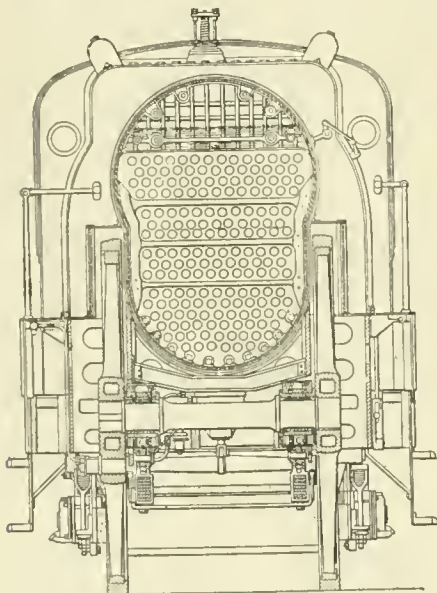

FIG. 23. SECTION OF BOILER OF THE THUILE LOCOMOTIVE.

hibited at Paris in 1900 by Schneider & Co., of Crenсот, France, and shown in Fig. 22. That engine was designed to haul trains from 180 to 200 tons, equal to about four Pullman cars, at 75 miles an hour on level roads, and was calculated to develop about 1,800 horse power.

There were four coupled wheels, a full truck at the front and a six-wheel truck

under the back end, although the necessity for this was not apparent, as there were only 59,000 lbs. on this truck. This makes less than 10,000 lbs. on a wheel for this truck, and under 15,000 for a four-wheel truck, which would seem preferable to the extra pair of wheels.

The driving wheels carried only 65,000 lbs., or about 16,000 on a wheel—but little more than was carried by the trailing

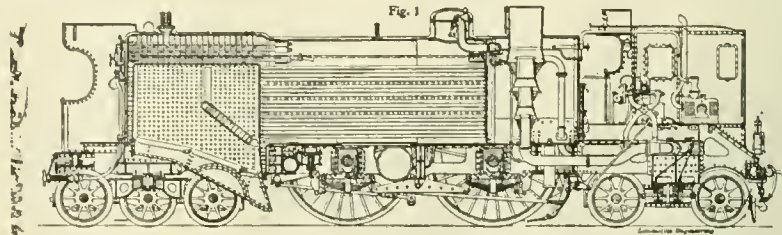

FIG. 22. THUILE LOCOMOTIVE.

truck. The total weight of the engine in working order was about 165,000 lbs., and the tractive power 15,652 lbs.

The boiler was of a flattened section, as shown in Fig. 23, similar to the "James Toleman" boiler, to get it between the wheels, which were 8 ft. 2½ ins. diameter, and the method of cross-staying is shown in the sectional cut. The diameter of upper portion was about 54 ins., while the lower is 48.5 ins. The height was 79 ins. There were 183 ribbed tubes, 2¾ ins. in diameter and 14 ft. 3 ins. long, giving a heating surface of 2,941 sq. ft., which with 263 ft. in firebox gave a total of 3,204 sq. ft. The boiler pressure was 213 lbs. The grate area was very large for European practice, being a trifle over 50 sq. ft.

Cylinders were 20 x 27½ ins., and a Walschaerts valve gear was used. The total wheel base was 40 ft. 2 ins., and entire length of engine, 46 ft. The cab, which had a wind-splitting attachment, was in front of the engine, while the fireman was at the rear—46 ft. away.

The tender was also of peculiar design, having ten 42-in. wheels under it. The wheel base was 25 ft. 7 ins., and the tender weighed about 49,000 lbs., empty, and 121,000 in working order. It carried about 6,000 gallons of water and 7 tons of coal. I was indebted to *Engineering*, of London, for the data given.

I examined that locomotive very carefully at the Paris Exposition and discussed its peculiarities with some of the most eminent engineers who were visitors at the show. The following conclude notes which I wrote to my paper about the Thuile locomotive:

"The engine shows traces of very careful designing and the construction work has been wonderfully well done. I listened to several well-known European engineers discussing the merits and shortcomings of the machine, and I certainly was surprised to find that the consensus of that opinion was favorable. The writer dislikes to be in the minority, but he has

enjoyed many opportunities of passing judgment on so-called original types of locomotives that were going to push the common types out of service. He never made a mistake of judgment in telling that the ordinary original type of locomotive was a fake. He has now no hesitation in saying that the Thuile will fall into rank with the Fontaine, the Raub Central Power, the James Toleman and

the Holman locomotives, which are all of amusing memory."

#### Railroad Enginemen as Chauffeurs.

Railroad men, especially those who have enjoyed the experience of running locomotives, are the most careful operators of horseless carriages to be found upon the public highways. This spirit of caution arises from several causes. A man accustomed to the running of a locomotive realizes the serious results that may come from breakage of even a minor part and the liability of even the strongest material to unexpected fracture. The railroad man also has the feeling that the absence of guiding rails lets an automobile roam too freely into ditches or into conflict with telegraph poles when anything goes wrong with the running gear.

Many wealthy people, owners of automobiles, pay very liberally for men competent to run and care for automobiles. We would urge upon such people to engage, as chauffeurs, men who have gone through the experience of running locomotives. Old firemen might do just as well, since engineers looking for jobs are not numerous. Accidents due to recklessness and incompetence of men driving automobiles are becoming so common that automobile owners desirous of preserving alive their family and friends would do well to engage railroad enginemen as chauffeurs.

The American Locomotive Company have recently received an order of 101 Four-Wheel Motor trucks for the Brooklyn Rapid Transit Company. These will be built entirely to designs prepared by the builders and will follow closely the M. C. B. standards, and embody as far as possible the practices of locomotive construction, thereby insuring strength combined with easy riding qualities, the two essential characteristics of the motor truck of the present day.

# General Correspondence

## C. & O. Consolidation.

Editor:

We received your postal card of September 30th and with interest have read over your description of our G-8 engine No. 631, shown on page No. 441 of your October issue. We have built two of those engines, and they were designed with the following objects in view:

To obtain a stronger frame than we are now using on our standard 22 in. X 28 in. engine. By substituting the Walschaerts for Stephenson valve motion, to permit of our more securely bracing the frames to each other. We increased the stroke 2 ins. over our standard engine, reduced the boiler pressure 15 lbs. per sq. in., haul the same tonnage as the other class of engine, and on account of the difference in the pressure and heat, have fewer boiler troubles.

Up to date the G-8 has been a very satisfactory engine, and has, thus far, borne out all we expected. We thank you for your note and very nice description of the engine.

J. F. WALSH,

Sup't Motive Power,

Chesapeake & Ohio Railway.

Richmond, Va.

## French Compounds.

Editor:

I have the honor to address to you a photograph of our Locomotive 2,990, which is in appearance the same as the Locomotive 2,975 which you asked for. These engines run on the Paris, Lyons and Mediterranean Railway.

The distribution of steam is made by the Walschaerts valve gear, and the apparatus for changing the stroke is the same as that described on pages 10 and 11 of the notice of our Locomo-

tives C-61 and 3,401 exhibited in Paris in 1900.

For completing the information I give you below the principal particulars relating to the valves of these locomotives.

The arc of a circle moved through

never been a believer in things wonderful; that is, I have held that there is always a good scientific reason, and everything can be so accounted for. But all this has changed. I am now almost ready to believe in airships, one

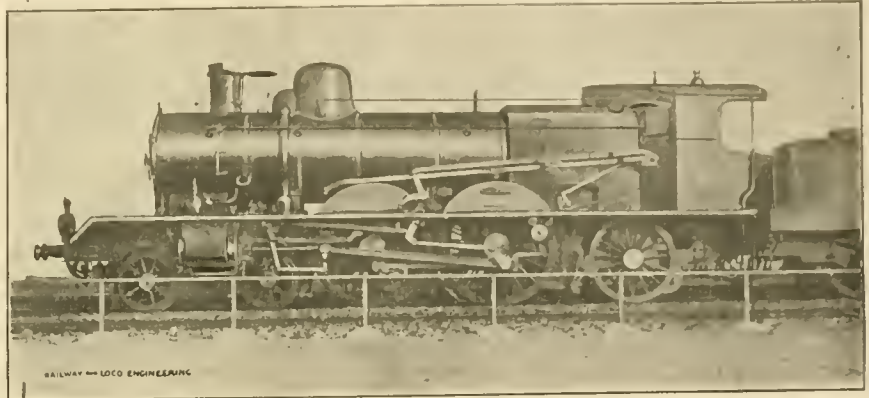

EXPRESS ENGINE, 4-4-2 TYPE, USED ON THE P. L. & M.

by the eccentric, for admission is 130 degs., and for the exhaust 70 degs. The maximum travel of the high pressure valves is 5.7 ins., and that of the low pressure valves is 4.92 ins. The steam opening for the high pressure valves is 1.33 ins. The inside lap is about 1-10 of an inch on the high pressure valve. The valve arrangement can permit 88 per cent. of the boiler pressure to enter the high pressure cylinders and 63 per cent to enter the low pressure.

L. MAIECHAL,

Engineer-in-Chief

Material and Power, P. L. M.

Paris, France.

## Slipping Shut-Off.

Editor:

I have quietly perused your excellent publication for many years. I have

track railways and even compound locomotives, and all this has been brought about by the simple fact we have here engines that are so imbued with the "old scratch" that they slip shut-off. I did not believe this, although attested to by half a dozen as good engineers as ever need be, and as truthful men as ever will be. I say I did not believe it until I saw it and experienced the same myself. That these engines will not only continue to slip when shut off, but will "cut loose" while drifting and slip enough to convert the most skeptical—and there are some—is certain. If you wish to attempt any explanation of this inexplicable phenomena, I vow attention. I wish to say there is no danger of my subscription lapsing. Others of the family, although not followers of the rail, are interested in the journal. There is always something for everybody.

J. C. McC.

Pittsburg, Pa.

[There was a lengthy and interesting discussion of this phenomenon in the pages of RAILWAY AND LOCOMOTIVE ENGINEERING some time ago. The letters from our numerous correspondents can be found by reference to the 1904 index, under the heading which appears over this letter. We refer the writer of the letter and any others interested in the question, to page 112 of our March, 1904, issue. The expression "slipping when shut off" is misleading. Many persons seem to think that under the

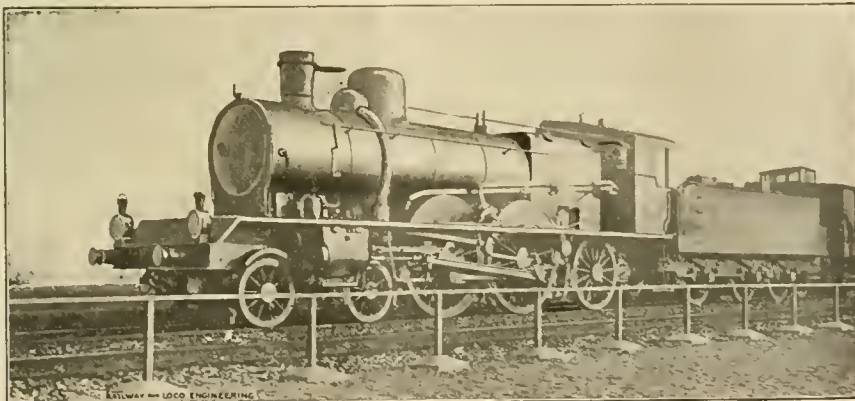

ATLANTIC TYPE ENGINE ON THE P. L. & M. IN FRANCE.

circumstances described, the wheels are revolving faster than the speed of the engine would warrant. As a matter of fact the wheels are not revolving as fast as they should for the speed of the engine, but the peculiar jarring effect produced very closely resembles the sensation caused by ordinary slipping under steam pressure, and has no doubt been mistaken for it. With throttle shut off, there is nothing to make the wheels spin round ahead of the speed, but there is every reason with bent pins, or sprung or slightly twisted axle, or engine out of quarter, to have the motion of wheels slightly retarded, and a slipping sensation produced.—Ed.]

### English Railway Cars.

Editor:

I have recently returned from an extended trip through England and send you the result of my observations on the types of passenger cars used in that country, and which I hope will be of interest to your readers.

The accompanying drawings indicate the three general types of British railway cars. The most primitive type, Fig. 1, is the shortest of all the passenger cars or "carriages," and has from three to four compartments. The wheel base is rigid with the exception of a very slight lateral motion which the bearings give. The car is from fifteen to twenty feet in length. These cars are very old. In fact, if some of them were not being continually rejuvenated by a fresh coat of paint their ancient mien would suggest Noah and the Ark. The second type of car, Fig. 2, is of about equal antiquity, but is a few feet longer and has from

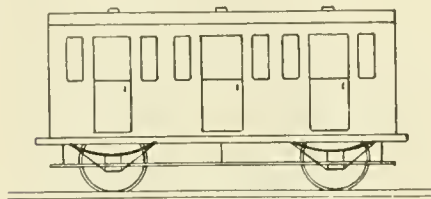

FIG. 1. OLD TIMER.

four to six compartments. This style of car is supported on three sets of wheels as shown in the diagram and has a rigid wheel base, with the exception of slight lateral play. These cars are some twenty-five feet and over. Needless to say that these two types of car are rough riding, especially in rounding curves and making cross overs, when they are attached to high speed trains, which is usually the case, for most of the English trains get up considerable speed over some sections of the route.

Such cars as the above mentioned are not choice by any means even though many of them are equipped with first class compartments. Consequently it de-

volves upon the traveler to hatch up a little mechanical instinct, run his eye down the length of the train, keeping it in the vicinity of the wheels, and look for a car with double, swivel trucks, such as is shown in Fig. 3, which belongs to the last and best variety. These cars have either four or six wheel trucks, the latter kind usually being placed under the sleepers and diners, and are by far the most comfortable cars to travel in.

All the cars are made up of compartments, except the diners and chair cars, and they are generally of two classes, namely, first and third. On all but a very few roads the second class compartments have been eliminated. Where to the third class on roads operating only second class accommodation is still ad-

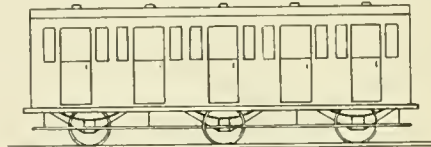

FIG. 2. SOMETHING BETTER.

hered to, the comfort of such corresponds first and third class cars. In many instances the first and third class compartments alternate in the same car, while in others there are separate cars for each class.

The compartments are isolated from one another and the doors, two for each compartment, open on the outside like the doors of the old-time stage coach. This arrangement is general, except in the more modern corridor cars, in which one of the doors of each compartment open to the outside and the other, into a corridor that runs from one end of the car to the other. A car of this type affords a means of communication between the different compartments and also with the other cars that make up the train, provided they too are of the corridor type. These cars are arranged in a variety of ways. Some types have a "luggage" compartment at one end, others at both ends, and still others are built for passenger accommodation only. This interior arrangement also applies to cars other than the corridor type.

In "hooking" for a railway journey, or, as we would say, getting a ticket, it is almost as important to examine the rolling stock as to buy a first class ticket. A first class ride in one of the short, rigid wheel base cars has no attractions other than a little more exclusiveness and a blue cushion to ride upon instead of a red one, which features are not of very great importance to the average sight-seer. A third class ride in a double-truck car is always to be preferred to a first class ride in a car of the rigid wheel base variety.

There are many peculiarities about the English railway cars that strike the American traveler very forcibly. The majority of passenger cars are low and

sawed-off looking at the ends, and in many instances they are coupled so closely together that at first sight the train appears to consist of only one extremely long car. The open spaces between the cars are so much restricted that it would seem almost impossible that such a train could round a curve.

The freight cars or "goods wagons" are exceedingly diminutive and the great majority of them are supported by only four wheels and have a capacity of from ten to fifteen tons. This type of car is equipped with a lever hand-brake and a simple link and hook coupling. The buffers, with which all cars, both passenger and freight, are equipped, serve as a cushion on a down grade and when the train is being brought to a standstill. Double-truck freight cars are exceedingly rare.

The couplings on passenger cars are not quite so crude. The passenger coupling consists also of a hook and link, but with the addition of a turn-buckle which serves to make the coupling taut and bring the spring buffers of each car to bear upon one another. The turn-buckle is manipulated by an iron bar attached thereto. On the end of this bar is a knob of the same material, whose weight keeps the bar in a perpendicular position and thus prevents the buckle from turning while the train is in motion. This method of coupling cars is necessarily somewhat slow, but as yet British conservatism has not reached a state of sufficient elasticity to accept the automatic coupler.

Another peculiar feature of some of the cars is the compartment for the conductor or "guard." These compartments are sometimes found in the regular passenger cars and sometimes in the baggage car or "luggage van." These are equipped with a kind of bay window which enables



FIG. 3. EASY RIDING COACH.

the conductor to see the signals ahead without being obliged to undergo the exertion of poking his head out of the window. These compartments are at the end of the car, and many of them have windows in the back end, when the car is at the rear of the train, which is usually the case, a good view of the track can be obtained.

The dining cars are very much like those in use on American railways with the exception that they are smaller. They afford excellent service and ride very smoothly. The sleeping cars are of the compartment type and are clean and comfortable and are not usually attached to day trains in America.

Nashville, Tenn.

E. C. LANDIS.

**Old Colony Equipment of Old.**

Editor:

Referring to the short sketch of the little engines called pups, illustrated on page 307 of the July number of RAILWAY AND LOCOMOTIVE ENGINEERING, I am much indebted to Mr. W. A. Hazelboom of Boston, Mass., for information in regard

the Bangor & Aroostook Railway, with its 500 miles of track and 5,000 cars of all kinds, furnish the public with finely equipped trains, both passenger and freight, reaching every point of commercial and scenic interest in northern Maine.

What to me was of more interest than the foregoing claims, were the changes

brought about by the company's storekeeper, Mr. Wm. Simmons. Through his courtesy I was shown over the works—the air brake department was an example of up-to-date appliances which were seen on every side, nothing from a monkey wrench to a twentieth century outfit was lacking. This latter machine

TABLE OF OLD COLONY MOTIVE POWER AS IT STOOD IN 1849.

Road No.	Names.	Wheels.	Weight.	Cylinders.	Builders.	Date.	Remarks.
—	Dorchester	12	53,300	16 x 20	Hinkley & Drury	184	Rebuilt as 8 wheeler. Sold to U. S. Govt.
9	Plymouth	12	56,400	16 x 20	Seth Wilmarth	1849	Rebuilt as 8 wheeler. (See page 317 RY. AND LOCO. ENG., July, 1907.)
4	Kingston	8	36,500	14 x 18	Hinkley & Drury	1846	Ran until 1878.
5	J. O. Adams	8	41,600	15 x 20	Do.	1847	" " 1889.
8	Mayflower	8	44,600	15 x 20	John Souther	1848	" " 1872. Replaced by the "Shawmut."
3	Patuxet	8	34,800	12½ x 20	Hinkley & Drury	1846	" " 1879.
18	Abington	8	38,500	14 x 18	Jabez Coney	1848	" " 1879, was first of the 8 wheelers.
6	Weymouth	8	39,000	14 x 18	Do.	1848	" " 1879.
7	Hingham	8	40,650	14 x 18	Springfield Mfg. Co.	1849	" " 1883.
—	Quincy	8	36,900	12½ x 20	Hinkley & Drury	1848	" " 1884, had been rebuilt and re-named Gridley Bryant.
—	John Eliot	8	36,950	14 x 18	Do.	1848	History unknown.
2	Gov. Bradford	6	26,500	11 x 20	Do.	1845	Sold to Bangor & Oldtown R. R. 1852
—	Gov. Carver	6	26,500	11 x 20	Do.	1845	Ran until 1878.
1	Miles Standish	6	26,500	11 x 20	Do.	1845	Sold 1851.
—	Comet						Ran until 1879. Was called "Standish" in later years. Sold with the Gov. Carver in 1851.

to these little engines which I was unable to give at that time. He sent me a list of the locomotive equipment of the Old Colony Railroad used in 1849, fifteen engines in all. The Gov. Bradford was one of three "pups," and was built by Hinkley & Drury in 1845, cylinders, 11x20 ins., weight 26,500 lbs., and some remained in service until 1878.

Dubuque, Ia.

GEO. H. BROWN.

that have come over the villages of Milo and Milo Junction, situated about one mile apart. To-day one would search long and carefully to find a landmark that would remind him of the quaint old restful conditions of years ago. The reason for all this was not far to seek, a never failing water power, that had wasted its usefulness on the desert air, caught the

was being operated for cutting band bolts on hose—the boy operator seemed to enjoy his work, and said he did.

This village consists of about 200 houses, built by the company for their employees, and rented at a nominal figure only to employees. Each house has bath and other modern appliances—cheap rent and some luxuries should make em-

**Old Rogers Engine.**

Editor:

I have had a copy of a very old Rogers engine made from the original, which was given to me by Mr. Thomas Rogers shortly before he died. He considered this engine the finest one ever turned out of his works up to 1855. It was built for the New York & Erie Railroad, and was used for fast passenger service between Jersey City and Delaware, now Port Jervis. Your readers may be interested in seeing this old time engine.

New York.

ANDREW J. FALLON.

**In Northern Maine.**

Editor:

A few weeks since, while on my vacation, I visited the picturesque section of Uncle Sam's northeast pleasure grounds—a land of mountain, hill and dale—hundreds of beautiful lakes and winding rivers, many with unpronounceable names—as a sample try one they call easy—Lake Chemquasabanticook.

I was interested in the improvements in means of transportation in the country north of Bangor—within the memory of the present generation there were no railroads north of Bangor and Oldtown, in the counties of Piscataquis, Penobscot and Aroostook—the toot of the horn of the driver of the stage coach often blended with the howl of the wolf, now the toot of the steam engine has succeeded both—

eye of a captain of industry and straightway was harnessed, to lighten the burden of man. It is here that the Bangor & Aroostook Railroad played the part of the magician, for it is here they have established their great car building and repair shops—it has been my good fortune to visit many such plants, but here every kind of material for building or repairing any style of car or engine used by the B. & A. were stored and systematized in such admirable shape that not a moment would be lost in finding any part or parts required. This fine arrangement was

ployees loyal, and from conversation with a number of them I believe it does—that this is a question well worth the attention of other railroad companies, is the opinion of

SUPERB.

Rochester, N. Y.

**Head Work in Little Things.**

Editor:

I remember distinctly in the shop where I learned my trade, the president of the company used to pay us a visit every day, and many's the time I have seen him going about with his hands full of wash-

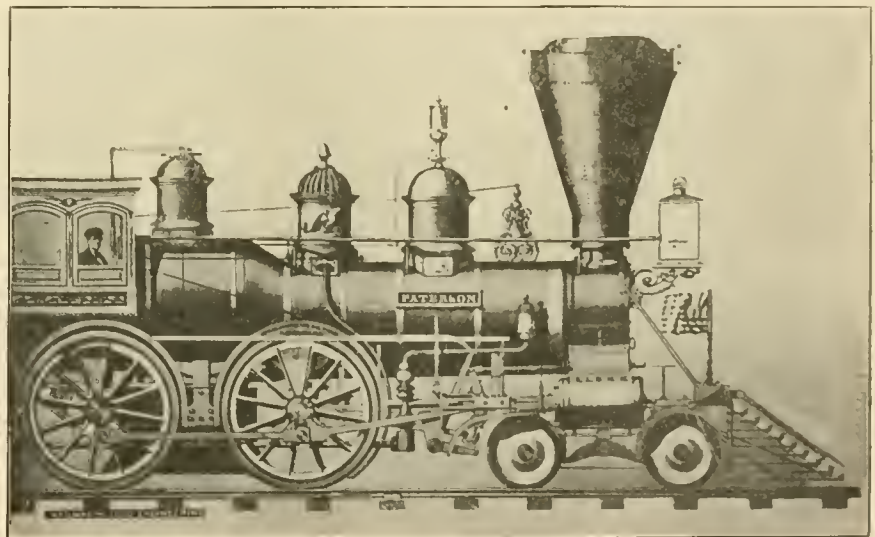

OLD ROGERS ENGINE, NEW YORK AND ERIE RAILROAD, 1855.

ers, nuts and nails that he had found lying around loose, in his rambles. He never failed to notice them and pick them up and score any man he found that was wasteful or slovenly in his workmanship.

The old man was wealthy then and is a great deal more so now. He was quite a genius on inventing things that were useful in his factory. The boys used to call him a skinflint because he was so saving of his materials, and a crank, because he was so particular about his work. I have known him to leave a job lie for a week or more because there was some small detail that did not seem to amount to a hill of beans to us, but it was an insurmountable difficulty until he could see his way clearly.

Some of his creations were original and most useful for the purpose intended. If he saw any tool or implement that was continually giving trouble or wearing out, his wits were at work instantly to remedy the defect and he generally got what he went after too. He reminded me in some respects of the old fellow in Kentucky that had run a distillery all his life, and this is the advice he gave his son who was going on a trip to see the country and what lay beyond the Kentucky hills: "My son, we have always been mighty

had this same ash hoe in the shop once a week for repairs and we always put the blade on with a nut behind, and one in front and one hole through the blade. The old man was a willing listener to the

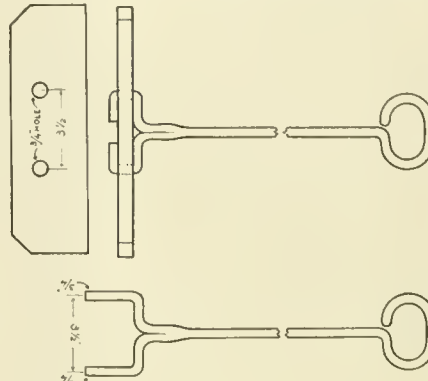

TOOT'S "STAY-TIGHT" FIRE HOE.

fireman's tale of woe, and his ready brain began to work on an improvement. What he evolved, I think, would be well for some railroads to adopt. I have made these same implements for many roads, but the old man's idea is the best ever. I give it in a sketch and can recommend it as strong, durable, can't turn on the handle, easily made and if it ever does

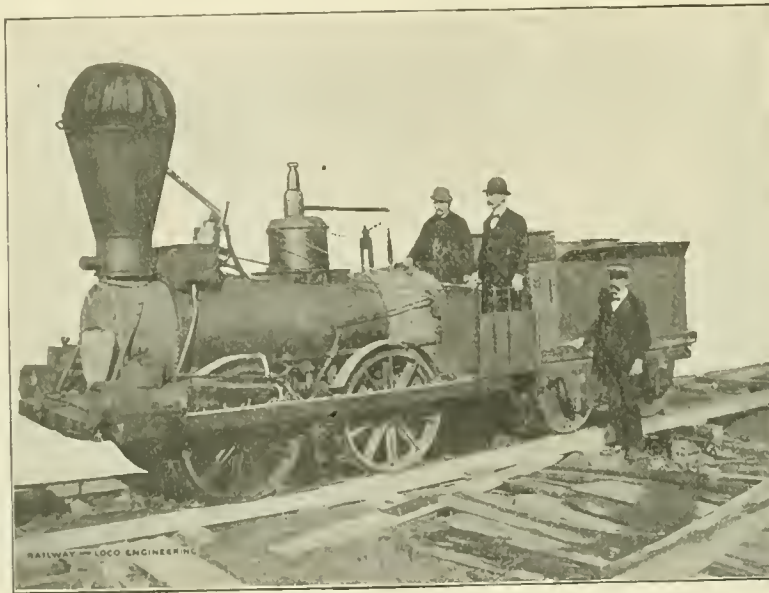

THE OLD "LION" ON THE WHITNEYVILLE & MACHIASPORT RAILROAD.

sparing about using water in this neck of the woods. You know how it will rust iron and steel, so be very careful how you drink it, for the Lord only knows what it will do to your stomach."

Our president and the old distiller had confidence in their own products and believed in what they knew was good, but did not care to take chances on something they were unfamiliar with.

In passing through the engine room one day, the old man came upon the fireman, cussing a blue streak on account of the ash hoe being loose on the bar and turning on the handle. The fireman usually

get loose, all one has to do is suspend it on a rail-plate, or any old thing that is solid and give it a blow with a hammer on each side and it is tight for some time to come.

T. Toot.  
St. Louis, Mo.

Old "Lion" of the W. & M. Railroad.  
Editor:

The recent dismantling of the Whitneyville and Machiasport Railroad, built in 1841, seems to call for something more than a passing notice.

This road was among the first construct-

ed in the United States, except possibly the Oldtown and Veasie road in Penobscot County, which was built about the same time. The first successful trial at railroading with locomotives in the United States took place in 1829 with one of three locomotives imported from England.

At the close of 1830 there were but forty miles of road completed in this country, and at the close of 1841, which was the year of the completion of the Whitneyville & Machiasport road, there were but 3,331 miles in all in the United States.

The "Phenix" was the first engine which ran over this road, was of English make, and was sent by Hinkley & Drury, of Boston, to perform the work, while the "Tiger," one of the engines recently shipped to Portland, was being built by them. This engine was completed and sent by schooner to Machiasport in 1842.

The "Lion," a companion engine, was also built by Hinkley & Drury. This locomotive was commenced in 1842 and completed in 1843. Only one of these engines was used at the time on this road, except for grading purposes or to make up trains.

When this road was new the return trip from Machiasport with a "light train" was frequently made in from 15 to 20 minutes. The road was  $7\frac{7}{8}$  miles in length, with wooden stringers covered with strap iron, and this speed may be considered remarkable under the conditions. There were ten single saws, six lath machines and a shingle and clapboard machine running day and night on the dam at Whitneyville at that time, and eight train loads of lumber were manufactured each twenty-four hours. This road was in active use for more than fifty years, lumber and freight being conveyed by rail until 1892, at which time it became so much out of repair that a train could not be run on the rails moving at a rate much faster than a walk.

The reason for the abandonment was that the falling off in the cut of lumber made the effort to provide for natural decay a losing game. From the start to finish the road was free to anybody who chose to ride upon it and take his own risk, and the accommodating engineer would always slow down or, for a lady or an old man he would come to a halt, that they might take passage or depart in safety at the "Old Country Road," near Machiasport.

Special trains have been run to convey parties to Machiasport to go on sailing excursions, and political lectures at Machias and Machiasport, and, unlike anything of the kind ever known in the whole history of railroading in the United States, they were always free; those who were thus favored not even deeming the services of the engineer and fireman worthy of a tip. During the fifty years of free riding few accidents occurred among those who availed themselves of the privilege, though



several were killed in various ways while connected with the service of the road. At various periods eight or ten different engineers were employed during the fifty years' service of the road. Dana Bullard was the first machinist employed on the engines and made occasional runs to the "Port."

A man by the name of Butler, however, was the first regular engineer. He was followed by Colonel Dorman who ran a short time; Michael Corbett ran several years, and Samuel Paul, machinist, ran occasionally. Corbett was succeeded by Cornelius Sullivan, the present owner of the "Agency" property, who ran twenty-three consecutive years. The others were Albion Dunning, Edwin K. Smith, John R. Sullivan, and finally Cornelius Sullivan, Jr., who had a more trying experience and participated in more railroad wrecks than all the others combined.

The Phenix was sent away years ago. The Lion and Tiger, which weigh with tender about nine tons each, were recently purchased together with the scrap iron and spikes of the road by Thomas Towle, Portland, Maine. Whether these engines will be broken up or preserved as keepsakes is not known; but the people in Machias felt that they were losing old and tried friends and before they were taken away photographs of them were secured by Albee Brothers, of Machias. These gentlemen were kept busily engaged several days making duplicates to supply those in this vicinity who were desirous of retaining memories of the past. Our illustration was made from one of these photographs. W. A. HAZELBOOM.

*Boston, Mass.*

#### Latest Cloudscratcher.

Our illustration shows a view from the office windows of RAILWAY AND LOCOMOTIVE ENGINEERING. The photograph was taken looking over Liberty street toward Broadway, where the latest and tallest cloudscratcher proudly stands. It rears its steel flagpole top 706 ft. above the sidewalk, and the building might be called the temple of domestic art, for in it is the shrine of the sewing machine. The factory for these machines is situated at Elizabethport, N. J., just opposite the repair shops of the Central Railroad of New Jersey. Both are busy hives of industry—one of them is a hummer and the other is the Singer.

The Falls Hollow Staybolt Company, of Cuyahoga Falls, Ohio, inform us that the fire on the 13th ult. which destroyed the building in which was housed the rolling mill plant, did very little damage to the machinery and the mill is now again running in better condition than before the fire. The officers of this company say they wish to thank their friends who, though urgently requiring staybolts, have waited until repairs were made.

#### Some Smooth-On History.

The history of Smooth-On, while not by any means ancient, is rather interesting. The manufacturers tell us that this compound was made in 1893 by Vreeland Tompkins, a student in chemistry and graduate of Rutgers College, the object being to make a chemical iron which could be easily applied to cracks and holes in iron, so as to make permanent repairs.

A compound capable of being used to make such repairs had to fulfill certain conditions. These were that it must metalize practically as hard as iron. It must expand while metalizing, so as to completely fill any opening into which it

centage of water, to the consistency of stiff putty and immediately applied to cold metal, as it metalized rapidly. In a few hours it became as hard as iron, having practically the same color and appearance and the same power of expansion and contraction. This cement, while useful where small amounts of cement were required, necessitated unduly hurrying the work when handling large quantities was required. By further experiments a solvent was found for this cement which would evaporate upon the application of heat; this enabled Smooth-On to be prepared and kept in the paste or fluid form until wanted for use.

There are now six Smooth-On preparations, each made for a special purpose. Smooth-On for foundrymen, the first Smooth-On Iron Cement made, is for removing blemishes from iron or steel castings.

Smooth-On compound for engineers, the second of the Smooth-On Iron Cements, is for making repairs on steam or hydraulic work, when the application can be made to cold metal.

The third Smooth-On Iron Cement placed upon the market is Smooth-On Joints. This cement is used for making joints on cast iron hub joint pipes.

Smooth-On Elastic Cement, the fourth Smooth-On product, was a step forward in the compounding of iron cements, as this cement is prepared in fluid or paste form and kept in that state until it is wanted for use, by packing in air tight cans. This fluid cement will run into very small cracks, holes or seams, filling them with iron, and by many it is called magic iron.

The fifth Smooth-On specialty, called Smooth-On Iron Cement Sheet Packing, is a combination of Smooth-On Iron Cement No. 1 and rubber. The Smooth-On in this packing has the same action as when in the powder form, namely that of expanding slightly when it comes in contact with steam, hot or cold water. It completely fills any uneven places in the flange faces, thus instantly making a tight joint.

The sixth Smooth-On specialty is the Smooth-On Coated Corrugated Steel Gasket. It is made from specially prepared mild, tough steel, stamped with concentric corrugations and then coated with Smooth-On Elastic Iron Cement. Flanged joints, where this is used, will withstand any pressure or temperature that the pipe will stand: the gaskets are not affected by steam, water, oil, air or ammonia.

Tommy—"What's an idgiot?"

Johnny—"An idgiot's a feller who don't know the difference between a smoke stack an' a sand box. A chump who don't know nothin'."

Tommy—"You're wrong there. It's the man who thinks he knows and doesn't."



VIEW FROM OFFICE WINDOWS OF RAILWAY AND LOCOMOTIVE ENGINEERING—LATEST AND TALLEST CLOUDSCRATCHER.

might be introduced and also force itself into the grain of the iron. When metalized, it must expand and contract to the same extent as iron. After two years' work this was accomplished, and the chemical compound made was named Smooth-On. It forms the base for the various Smooth-On Iron Cements. The chemist of the Smooth-On Manufacturing Company of Jersey City, N. J., has given careful study to the subject for twelve years, and has succeeded in compounding the iron cement known generally as Smooth-On.

Smooth-On Iron Cement was first prepared only in the form of powder and used by mixing it with a certain per-

### Seventy-five Ton Flat.

A very practical test of the carrying power of a steel flat car was recently made at the Collinwood shops of the Lake Shore & Michigan Southern Railway. One of our illustrations shows an 80-ton consolidation engine mounted on the car whose nominal capacity is 150,000 lbs. The car was not over-strained or damaged in any way, but held up the iron

Ivatt, locomotive engineer of that road. This test, like the one on the Lake Shore, was what automobile people might call an endurance test, as neither of these steel cars would be called upon to carry just this kind of load in everyday traffic.

The Lake Shore flat measures 35 ft. 6 ins. along the side sills and is 9 ft. 10 ins. wide over all. It is made of two outside sills, two double intermediate

I-beams weighing  $12\frac{1}{4}$  lbs. to the foot and placed side by side. These butt against the needle beam at one end and the body bolster at the other. The inner intermediate sill is a 10-in. I-beam between body bolster and needle beam. The stake pockets are placed on the inside of the outside sill and the stakes therefore pass through the floor of the car and have the full depth of the outside sill at least

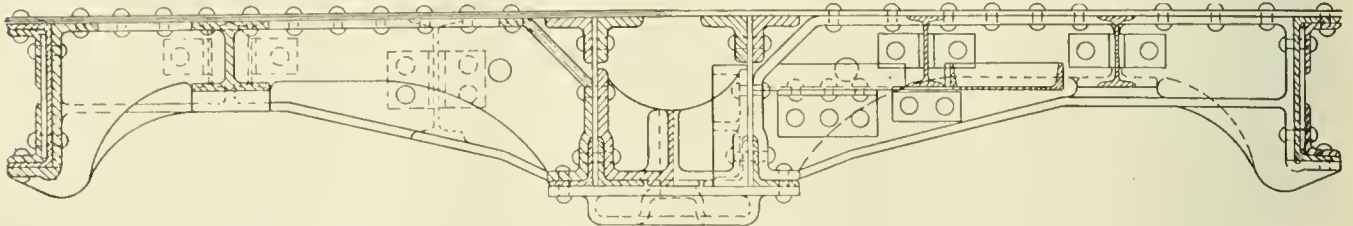

SECTION THROUGH BODY BOLSTER OF LAKE SHORE HEAVY STEEL FLAT CAR.

horse in good style. This means a theoretical overload of about 10 per cent. The car was not moved about, as the test was intended to be one of dead weight only, and it satisfied the designers that the car was all that it was intended to be. The car was built by the railway company and the photograph and blue prints from

sills and two centre sills. There are thus eight longitudinal sills in the car. The side sills are made of  $\frac{1}{2}$ -in. plate edged top and bottom on the outside and inside with angle irons turned so that the flanges are outward. The sills slope down back of the body bolster from  $12\frac{1}{4}$  ins. to  $21\frac{1}{4}$  ins. at the needle beams. The centre

on the one side where the sill is deepest.

The part of the car between the body bolster and the end sill is strongly braced, for in addition to the side, centre, and the extensions of the four intermediate sills, there are at each end, heavy plate and angle bracing in a diagonal direction from centre to outside sills. The end sills are made of 12-in. channels weighing 40 lbs. to the foot. The body bolster of this car is made up of three heavy steel castings, the outer ones being each 3 ft. 4 ins. wide and extending from outside to centre sill of the car. Each has three heavy transverse webs with broad flanges top and bottom. Each is deeply lipped below the outside sills and butts against the centre sills, to which they are riveted with wide flanges. The structure of the outside intermediate sill is carried through the body bolster in the form of cast web and flanges which are an integral part of the bolster. The centre casting which lies between the centre sills is a heavy and substantial webbed and flanged steel casting 3 ft. 4 ins. long, by 12 ins. wide. The car is covered by two layers of plank each  $1\frac{3}{4}$  ins. deep.

There is a cover plate over the whole of the body bolster area and with the deep centre sills and the double edged side sills and the substantial bracing of the whole, the car is of exceedingly stiff and strong construction, and altogether it is one calculated to successfully resist the exceedingly severe usage to which a flat car, heavily loaded, is subjected not only in long trains at the present day, but also in the gravity sorting yards used by many of our more important railways. The car is intended for regular service, but heavy and concentrated loads are its specialty.

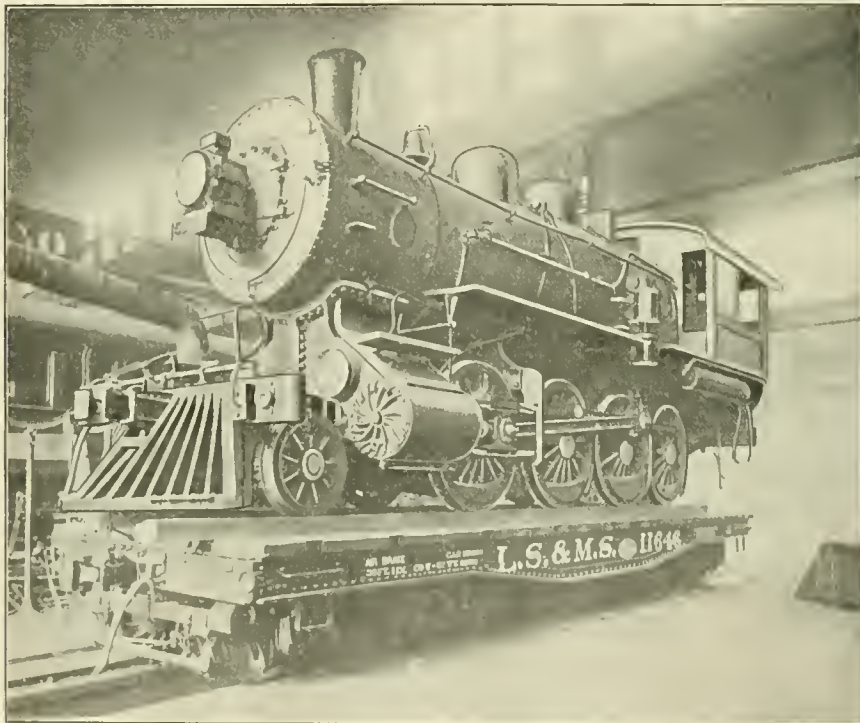

LAKE SHORE STEEL FLAT CAR TESTED WITH HEAVY LOAD.

which our illustrations have been made were received through the courtesy of Mr. Le Grand Parish, the S. M. P. of the road.

In our August issue, page 355, we showed a somewhat similar test made on the Great Northern Railway of England, where one of that company's eight-foot "singles" was mounted on a 40-ton well wagon, which was designed by Mr. H. A.

sills are  $14\frac{1}{2}$  ins. deep at the ends and slope down like the side sills, but have a depth of 24 ins. at the needle beams. The four intermediate sills are made of I-beams 10 ins. deep and weighing 25 lbs. to the foot. The needle beams are made of plates and angles similar to the outside and centre sills. Between the needle beams and the body bolster, the outer intermediate sill is made of two 6-in.

Think of your own faults the first part of the night when you are awake, and of the faults of others the latter part of the night when you are asleep.—*Chinese Proverb.*

### Floating a Railway Tunnel.

Our readers will remember the description of the Subaqueous tunnel at Detroit which we gave in the September issue of our paper, page 411. This tunnel is on the line of the Michigan Central Railroad

### Love of High Speed.

Word has gone forth that Pittsburgh, Pa., is suffering from an epidemic of reckless automobile speeding. Those who sent out the dispatch containing the above information might have just-

gets control of any speed making vehicle, be it a carriage pulled by a fast horse, an automobile or a locomotive.

It is human nature to seize a piece of the Flying Carpet of Eastern fable, and it is well known that the young engineer or the freight engineer temporarily called upon to pull a passenger train is likely to attain the most reckless speed. But he has his road all to himself and the likes of him; he has not got to reckon with the presence of pedestrians, ponies, pigs, poultry, or other lawful users of the highway. Likewise he has an elaborate system of signals to notify him of danger ahead. Yet those familiar with train operating know it is not every engineer that has aptitude for fast trains, and moral courage is required of him who would run at a mile a minute. "The engineer of a limited goes crashing into the night, knowing every foot of the track, reading every light, and putting his faith in others. Sometimes the lights are on the other side, and the fireman, stripped to his undershirt, even in zero weather, springs forward to the seat he never uses and calls the signals. The engineer repeats them back, looking straight ahead, and the fireman, sweating at every pore, goes back to his everlasting shovel. Curves are taken at full speed. Towns are passed with the throttle wide open. Yards dancing with clear red and green lights, each of which is a voice and a sign to the engineer, are here one minute and gone the next. There must be

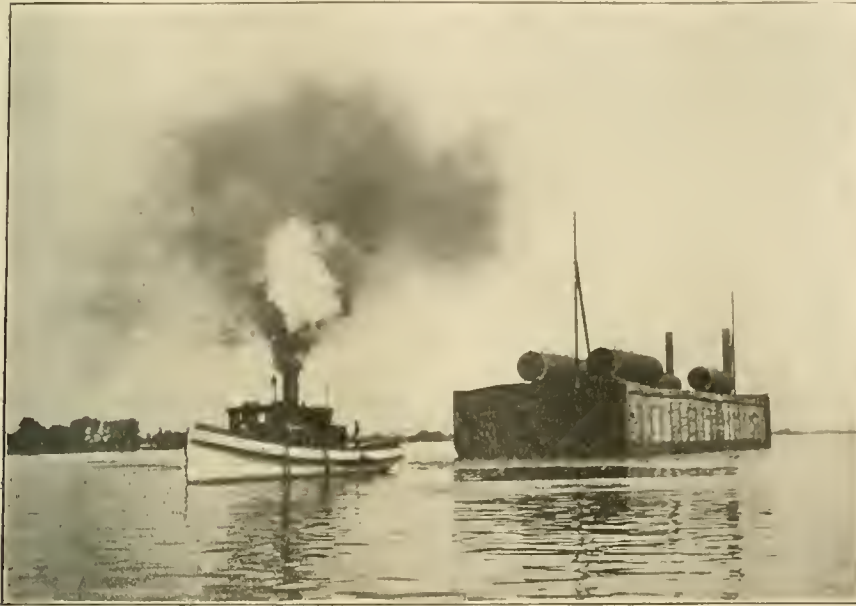

RIVER TUG TOWING FLOATING TUNNEL TUBES AT DETROIT.

and connects the American and Canadian sides of the river.

The first one of the tube sections was recently floated off from the builder's yard and towed to its place, as shown in the illustrations which we are able to present this month. The excellent photographs from which our half tones are made, were taken by Mr. L. Pesha, photographer, of Marine City, Mich.

The tubes are made in pairs and the diaphragms which project out from the sides, have, as we previously explained, been covered on the sides with 3 in. planking. This helps to keep the tubes afloat and when the tubes are in place the plank slides form a sort of receptacle into which the concrete is poured, so as to permanently bed the tubes in solid material.

The ends of the tubes are blocked up with temporary bulkheads, made of wood and the tubes contain air which adds to their buoyancy. On top of the tubes are two cylinders in which compressed air is carried. It thus will be seen that with the aid of wood and confined air, the tunnel tubes float on the surface of the water, and the sinking is done by gradually letting out air enough to cause them to slowly settle. They are towed by a river tug and are steered in between the rows of guide piles and then sunk to their permanent place in the river bed. The work is unique of its kind and when the tunnels are opened for traffic the Michigan Central car ferries will practically be things of the past.

ly parodied a remark made by a Scots divine who was preaching on the text, "David said in his haste, All men are liars," and remarked, "David, if you had lived in this parish you would have

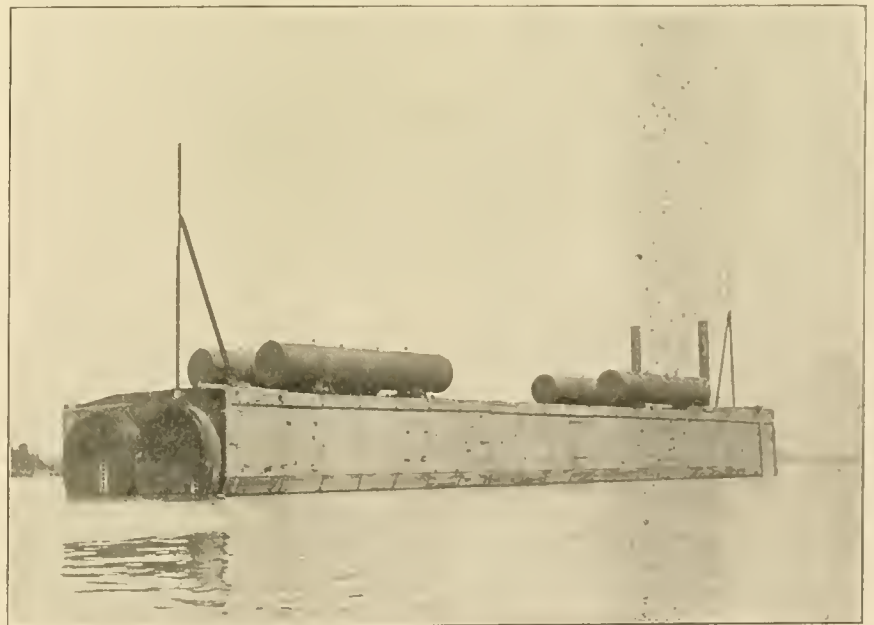

M. C. R. R. SUBAQUEOUS TUNNEL TUBES FLOATING ON THE WATER READY TO BE SUNK INTO PLACE IN THE DETROIT RIVER.

made the same remark in your leisure." The Pittsburgh man might have said that there is an epidemic of reckless automobile speeding all over the country. There is a tendency to reckless speeding by nearly every person who

physical courage in the teeth of all this, but greater and better still is the moral courage of the man in the cab—his confidence in others as well as in himself, and his readiness to assume responsibility on the spot."

# Railway and Locomotive Engineering

A Practical Journal of Railway Motive Power and Rolling Stock.

Published Monthly by

**ANGUS SINCLAIR CO.**

136 Liberty Street, New York.  
Telephone, 984 Cortlandt.  
Cable Address, "Loceng," N. Y.  
Glasgow, "Locauta."

**Business Department:**

ANGUS SINCLAIR, President.  
JAMES KENNEDY, Vice-President.  
JAMES R. PATERSON, Sec'y and Treas.

**Editorial Department:**

ANGUS SINCLAIR, Editor.  
GEO. S. HODGINS, } Associate Editors.  
JAMES KENNEDY, }

**Advertising Department:**

Eastern Representative, S. I. CARPENTER, 170  
Summer St., Boston, Mass.

**British Representative:**

THE LOCOMOTIVE PUBLISHING CO., Ltd.,  
Amen Corner, Paternoster Row, London, E. C.

**Glasgow Representative:**

A. F. SINCLAIR, 15 Manor Road, Bellahouston,  
Glasgow.

**SUBSCRIPTION PRICE.**

\$2.00 per year, \$1.00 for six months, postage paid in the United States, Canada and Mexico. For other parts of the world, \$2.50, or ten shillings. Single copies, 20 cents. Remit by Express Money Order, Draft, Post Office Order or Registered Letter.

Mailing address can be changed as often as necessary—always give old and new address, and if you subscribe in a club, state who got it up. Please give prompt notice when your paper fails to reach you properly.

Entered at the Post Office, New York, as Second-class mail matter.

Copyright by Angus Sinclair Co., 1907.

For Sale by Newsdealers Everywhere.

## The Why of Superheating.

Not long ago some very interesting experiments were made by Dr. Mellanby, in which the properties of superheated steam were the subject of investigation. The results obtained were communicated to the West of Scotland Iron and Steel Institute in a paper read by the distinguished scientist himself.

Some interesting facts concerning the condensation of superheated steam were brought to light. When superheated steam passed through uncovered pipes there was only a slight fall in temperature and comparatively little loss by radiation. On the opening of a drain cock at or near the bottom of the pipe system a considerable quantity of water was drawn off, though the steam temperature remained high. When dry steam alone came from the drain cock the experiment was repeated, time having been allowed for condensation to take place, and again a good deal of water came off, although the superheated steam was still exceedingly hot. The pipes were then covered with a non-conducting material and superheated

steam turned on. Practically no condensation was observed.

In the first two cases superheated steam actually condensed and gave up some of its superheat. In the third experiment the temperature of the covered pipe was above the condensing temperature of the steam. From these experiments it seems fair to assume that superheated steam when introduced into the cylinders of a locomotive or other engine is condensed, as the walls of the cylinder are necessarily below the temperature of the superheated steam and consequently condensation take place.

Dr. Mellanby's theory of why superheated steam is economical is not that it is able to resist initial condensation, but that there is a considerable reduction in that form of loss commonly called the "missing quantity." This loss, he believes, is almost entirely due to valve leakage. The check to this form of loss is the why of superheating and upon it, he thinks, the claim to economy in the use of superheated steam should be based.

In an article published in our editorial columns in the January, 1907, issue, and entitled "Leakage of Slide Valves," we gave the results of some instructive experiments made by Prof. L. V. Stanford, of the University of Pennsylvania, to determine the amount of this form of loss. If the exhaust steam from an engine be condensed and the water weighed, there is usually a considerable difference between this weight and the amount got by the analysis of the indicator card. This difference is the "missing quantity." Cylinder condensation and slide valve leakage are generally regarded as the cause of this loss. Prof. Stanford's experiments showed that valve leakage is much the larger factor in the production of this "missing quantity."

These experiments, made at the University of Pennsylvania, confirm the results of some earlier work by Dr. Mellanby, which he described in a paper on "Steam Jackets," read in 1905 at a meeting of Institution of Mechanical Engineers in England. He found that the greater part of the "missing quantity" was directly due to slide valve leakage, and that initial condensation was but a small fraction of this form of loss. The results of all these experiments show slide valve leakage to be a more serious loss than is generally supposed.

Two of the experiments made by Prof. Stanford were for the purpose of ascertaining the amount of slide valve leakage, and the method employed was most ingenious. He found that with a balance plate over the valve, 43.9 per cent. of the total steam consumption as determined by a previous test, leaked

away, and with the balance plate taken off and the hole in the top of the valve plugged up, there was still a valve leakage of 13.9 per cent.

Dr. Mellanby believes that the use of superheated steam reduces this form of loss, and that therein lies its superiority over ordinary saturated steam, and not on account of any prevention of initial condensation. That superheated steam can exist in the presence of water is shown by the fact that when passing through pipes containing water pockets it does not lose its superheat or evaporate the water.

It would be most instructive if some experiments such as were made by Prof. Stanford with saturated steam could be made with superheated steam as used in locomotives, and the actual economy of superheated steam as regards slide valve leakage be accurately determined. We commend this feature of the case to the engineering faculties of our several universities where experimental work of this kind has been so ably and so faithfully performed.

## Fitting Piston Rings.

The constant desire for cheapness in machine shop work is the cause of many of the troubles on twentieth century locomotives. In no part of the engine is this more manifest than in piston rings, the manufacture of which has come to be something of a boast in some shops where they are turned out at the rate of so many hundred a day. The first mechanic chucks a casting in the lathe, and a cut is taken off inside and a cut outside. Then each ring is sliced off. Following this the vise hand cuts them apart, squeezes them on the piston head and lets them go at that.

If time were taken to study the form which the split ring has assumed and compare it with the true circle of the cylinder which it is supposed to fit, it would be seen that the packing ring had become oblate in form with an abnormal extension towards the points of separation, or giving the ring a somewhat pear-like shape. The idea that the admission of a little steam inside the ring will stiffen it out to fit the circle of the cylinder is a hollow delusion. It never will fit, except after long wear and after the loosening ring has moved round until the split portion is on the top.

This recalls another persistent defect in piston ring construction. The necessity of holding the piston ring in position by a dowel pin is so obvious to all who have ever removed pistons from cylinders that the universal use of pins might be looked for as a certainty. The

general method in placing the piston in the cylinder is to break the joints, as it is called, that is to place one joint at one side of the cylinder and the other joint at the other side as far away from each other as possible. The piston is no sooner at work than the two openings begin moving towards each other; that part of the ring where the cut is, being lighter than any other part, naturally finds its way by easy stages to the top. A considerable blast of steam has a clear passage at all times, and thus the quick, cheap piston ring wastes the steam to a considerable extent, and does its day after day.

To go back to the construction of the piston ring, the best method is to make the rings at least one eighth of an inch larger than the diameter of the cylinder, and after splitting the ring, it should be re-chucked in the lathe and sprung close at the joint and cut down to the desired size. A dowel pin should be put in the bull ring, or in the piston, and a notch cut in the piston ring, fitting as carefully as possible. These operations take time, but every part of the locomotives should be constructed and fitted together in the best possible manner. It may be added that there are other reasons why the piston rings should be held in place. There is a danger in some instances of the piston rings passing over the steam ports, and the result is always disastrous. More or less cutting of the cylinder follows, and thus the life of the cylinder itself is shortened by cheap, ill-fitting piston rings, and the constant waste of steam completely destroys the so-called value of all cheap, and quick, and careless fitting.

#### Inductive Reasoning.

If any one was to see two men walking down the street, coughing violently, would he have any sort of reasonable ground for saying that the townsfolk were all suffering from acute sore throat? The answer is obviously no; he would not have sufficient reason for any such statement.

This is in concise form just the kind of error often made by those who desire to reason from single instances up to a general law. Such a form of reasoning is legitimate enough if you have a sufficient number of single instances, and this form of reasoning is called the inductive method. It is opposite to the deductive method which reasons from a general law down to particular cases.

As an example of deduction it may be said, if it be a general law that collie dogs can be made to take care of sheep it is fair enough to assume that the particular collie dog which you think of buying can be so taught, or has the faculty. That is a deduction from the observation of the generally exhibited trait of the dogs.

Now as to inductive reasoning, if you want to be sure that all bodies fall equally fast in a vacuum, it will not do to rest the induction on one or two isolated examples. A very large number of single instances all going one way must be before the experimenter, or he may fall short of the truth. It is here that the old proverb comes in, "The exception proves the rule." The one or two clearly defined exceptions show that the rule exists. A great majority of so-called exceptions would make the rule go the other way, and if the instances conform to the rule they are not exceptions.

A great deal of human knowledge is based on properly applied inductive reasoning, and a good many things we rightly believe to be true in railroad work are inductions. In the preparation of reports for our various mechanical societies such as the Master Mechanics', the General Foremen's or the Traveling Engineers' Associations, a committee often sends out a series of questions to responsible persons on a large number of railroads with the object of getting replies. The more replies they get the greater the number of single instances they have to work on in making an induction or in framing the statement of the general law or the usual practice.

Turn to the report of the committee on the smoke nuisance in the Traveling Engineers' Convention reports published in another column of this issue and note the tone of disappointment at the comparatively small number of replies received. This emphasizes the great importance of sending in replies to committees. They want to get at the general law, they want to make a correct induction, and a few replies are not sufficient, if the committee's work is to be of value. This is not peculiar to the Traveling Engineers' Association; committees of all our associations have before now found themselves short of sufficient data for the reason that replies are few.

It is not too much to say that it is the correct application of the inductive methods of reasoning which makes the work of any of our railroad or engineering societies of value. When replies are forwarded in sufficient numbers, it then becomes the work of a committee to sort and sift and tabulate the information given, and when that is done properly, a correct induction can be drawn and a satisfactory advance made in our effort to increase our stock of useful knowledge. The proper interpretation of the facts presented or the statements made is, of course, necessary to a correct induction, but the first and primary requirement is to get a sufficient number of facts before the committee.

#### Both Parties Benefited.

Many people seem to regard the educating of railroad apprentices by the companies employing them as in some sense a philanthropic act. The fact, however, seems to be otherwise. Mr. A. Devine, the drawing instructor of the apprentice shop classes on the New York Central at West Albany, N. Y., brings out the fact that the opportunities offered to the boys react beneficially for the company. He says:

"There is one point, however, which I believe has received very little attention, namely, the quantity and quality of boys who are now applying for positions as apprentices due, no doubt, to the four years' technical training which they receive during working hours and paid for, the increased rate of pay per hour and a thorough knowledge of whatever trade they may choose.

"Before the new system was inaugurated at West Albany it was almost impossible to secure the right type of boy to learn the trade and the officials were compelled to take whatever came along, which resulted in a large number of deficient boys. It was also very difficult to keep these boys, due to the low rate of six cents per hour and the lack of a system of shifting, which deprived the boys of gaining a thorough knowledge of their trade.

"Conditions are entirely changed since the new system went into effect. Where heretofore we had to wait for a boy to come along to apply for a vacancy, we now have an apprentice waiting list, having eleven on it at the present writing. This allows us to take our pick, which results, as a rule, in our securing boys above the average. Our present shifting system, where the boy is put through all branches of his trade, from the bottom up, during his four year course, cannot but help to appeal to the ambitious apprentice, and the additional two cents per hour increase, although small, is quite an inducement.

"During the past year the number of apprentices at this point has increased from 69 to 93. This number is divided into three classes of thirty-one to each class, who attend school twice a week from 7:00 A. M. to 9:00 A. M. With three or four exceptions, the boys are very enthusiastic over their class work, and seem to take to it like ducks to water. We have nine boys who have had no previous experience in drawing who are capable of sketching, drawing and tracing a consolidation type main rod, complete, without any help from the instructor. I think this very good work, considering that this was done after about 117 hours of schooling, and should show the advantages derived from the simple method

of training as mapped out by Mr. Russell and Mr. Cross.

"Last winter we had an evening class for shop employes other than apprentices with a membership of twenty-nine. On October 14th next we intend to start the class for the coming winter, and have no doubt but that we will have a membership of thirty-five, the limit of our class room.

"The tuition fee has been fixed at \$1.25 per month, or \$7 for the full course of six months; this fee to include drawing paper, blank problem paper, instruction prints, problem sheets and the loan of a drawing board. A set of drawing instruments, 'T' square, angles, etc., can be purchased through the instructor at greatly reduced rates. With slight modifications, the courses for the evening classes are the same as for the apprentices. These classes are held every Monday and directly after working hours, from 5 P. M. to 7 P. M., during the six months' course."

#### Smoke Prevention.

We have devoted an unusual amount of space this month to the proceedings of the Traveling Engineers' Convention. We are moved to do this because we believe that the report is particularly valuable to every railroad man who takes an interest in his business, and because we believe that the very useful papers and discussions would not be read at all if we had not placed them before our readers. Our experience convinces us that the proceedings of railroad associations and clubs receive very little attention unless they are published in some paper while the subjects are still fresh in the minds of those connected with the organizations or interested in what has been done.

The principal paper published this month, with a very full discussion thereon, relates to Smoke Prevention, a matter which has come very prominently to the front during the last five years, and one that will always be kept alive by health authorities and people interested in preventing the atmosphere of cities from being contaminated by smoke. Attempts to prevent smoke from being generated in the combustion of bituminous coal have been carried on almost since steam boilers first came into use, and there has always been antagonism between the furnace users and the health authorities. A great deal of silly twaddle has been spoken and written about the injurious effect of furnace smoke, but it is a subject on which cheap reputation can be secured, and the public, who are our masters, have come to regard the emission of smoke, as a

nuisance, so it remains with the boiler users to do all in their power to reduce as far as possible the cause of complaint. Until very recently railroad companies and their officials have done almost nothing to restrain the smoke generation of their locomotives. It used to be the regular practice to fire by the appearance of the gases passing out of the smokestack, and when they ceased to be densely black the fireman was blamed for neglecting his work. The idea had not gone forth that proper combustion of the coal approached smokeless conditions. The firemen and engineers were not to blame for causing the firebox to vomit smoke, for it was one easy way of generating steam, and the men had received no instructions as to how smoke might be diminished or prevented. Knowledge relating to the principles of combustion has spread rapidly lately, and the traveling engineers are now carrying the burden of enlightening the engine-men under their charge.

While smokeless firing is something to be desired there is now a tendency to expect too much from the engine-men in this regard. Some kinds of coal cannot be burned under any circumstance without the generation of smoke, and nearly all kinds of coal will cause smoke when the combustion is forced beyond the easy capacity of the firebox. That means that nearly all locomotives will emit smoke when working hard, which seems to be the regular condition of motive power operation these days. An engine pouring out volumes of black smoke when standing idle indicates carelessness that is likely to lead to the grief of the parties responsible. It is such manifestations of carelessness on the part of engine crews that excites health authorities to demand the elimination of smoke. When men work intelligently and carefully to reduce the smoke nuisance as low as possible they are not likely to suffer discipline from their officials or prosecution from municipal authorities.

#### Car Foremen Discuss the Code.

There is one or two facts evident to anyone who will take the trouble to peruse the proceedings of the Car Foremen's Association of Chicago at their September meeting. The subject for discussion was the M. C. B. rules of car interchange. One of these facts is that the M. C. B. code is not entirely free from a certain amount of ambiguity, and the other one is that the Car Foremen's Association ought to be in a position to offer some very practical suggestions when the question of revising the code comes up next year.

The discussion as carried on at this meeting was for the purpose of seeing how the new rules were to be interpreted, and each of the speakers gave his opinion as to how the alterations passed at the M. C. B. convention last June were going to work out in actual practice. The opinions expressed were not the result of a haphazard reading over of the code, but were from men who were accustomed to do the work required in handling the interchange of the cars. There is no part of railroad operation where the game has to be played more strictly in accordance with the rules than in the case of freight car interchange.

The Car Foremen's Association is working along right lines in discussing the meaning and scope of the rules as the revised code goes into effect. It is one of the fundamental principles of every day life that knowledge is increased by the interchange of ideas, and an expression of thoughtful opinions often helps to clear away much that appears to be obscure and has a tendency, if we may so say, to standardize the interpretation of the code.

#### Santa Fe to Educate Apprentices.

The movement among railroad companies to provide educational facilities for their apprentices is making very satisfactory progress and we are pleased to note that the Atchison, Topeka & Santa Fe Railway, one of the greatest transportation companies in the world, is about to introduce a system for instruction of apprentices in their immense shops at Topeka. Vice-President J. W. Kendrick is the moving spirit in this beneficent movement and the interest which he displays insures success. Keeping alive educational methods on Western railroads, where distractions are less numerous than they are in the crowded cities of the East, is comparatively easy and we anticipate that in a few years the Santa Fe system will be celebrated for the scientific attainments of its mechanics.

As a beginning of the work Mr. F. W. Thomas, who is at present engineer of tests, will be supervisor of apprentices in the local shops. Five instructors will be taken from among the experienced employees, whose duties will be to look after the apprentices and see that they are instructed in all kinds of work. One instructor will be in charge of twenty-five apprentices.

There will also be a drawing school where boys will be taught mechanical drawing, practical arithmetic and the rudiments of mechanics. The school hours will be from 7 to 9 A. M. and from 1 to 3 P. M., after which the students will report to the various foremen and proceed with their work in the shops. The school will instruct machinist, blacksmith, boiler-

maker, patternmaker, tinner, painter and all the metal-working apprentices. Schools will be established at other points on the Santa Fe system.

#### Book Notices.

**Laying Out for Boiler Makers and Sheet Metal Workers.** Published by The Boilermaker, New York, 1907. Price \$4.00.

This book has been compiled from a series of articles in "The Boilermaker," which were written for the purpose of giving a practical boilermaker the information necessary to enable him to lay out in detail different types of boilers, tanks, smoke-stacks and indeed all sorts of irregular sheet metal work. The book is printed on good paper. It has 190 pages, 10 x 13 ins., and there are a profusion of illustrations, all clear line cuts, and the size of the page enables them to be of such dimensions as to be easily read. The first chapter is on the subject of laying out and the second is on triangulation. These chapters explain the methods employed, and give rules, definitions and some simple problems. Chapter III. takes up the laying out of a tubular boiler, and Chapter IV. describes the laying out of a locomotive boiler. Chapter V. deals with the laying out of the class known as Scotch boilers. Chapter VI. deals with the subject of repairs to locomotive and other types of boilers. Chapter VII. is on the construction of steel stacks, and Chapter VIII. takes up a number of miscellaneous problems. The book is practical, and should be a valuable help to those who use it.

**The Blacksmith's Guide,** by J. F. Sallows. Published by the Technical Press, Brattleboro, Vt., 1907. Price, cloth, \$1.50; leather, with round corners, \$2.00.

The methods described in this book have been developed and tried by the author during many years at the forge. Attention may be called to the chapters on hardening, tempering, case-hardening, etc. The output of any machine shop depends very largely on the character of its small tools. The processes used by the author in hardening these tools are fully explained in the book which is well illustrated throughout with line cuts and half tones. The author knows what it is to have to get out work with the ordinary appliances at hand and he tells how to do it. He gives plain directions for making an oven or forge for tool steel; a furnace for high-speed steel; a case-hardening furnace, and a brazing furnace. There are two colored charts at the back of the book given as guides in hardening and tempering. One is a heat chart, showing the colors of steel when heated to different temperatures and by the aid of which an idea can be

formed of the degree to which tools should be heated before dipping. The second is a temper chart giving the colors to which tools should be drawn if it is desired to harden them in this way.

**Valve Gears and Indicators.** By Walter S. Leland and Carl S. Dow. 150 pages, 105 illustrations. Published by the American School of Correspondence, Chicago, 1907. Price \$1.00.

This is practically two books in one, giving a good, clear explanation of details too seldom understood even by engineers themselves, but necessary to the complete mastery of the various applications of steam distributing apparatus.

#### Narrow Gauge.

Binks was hurrying across the station yard wrapped in thought and a heavy overcoat when his contemplative mood was brought to a sudden termination by

#### Austrian Rail Motor Engine.

In 1903 the officers of the Austrian State Railways had before them the question of working the light traffic on many of the branch lines by means of steam, electric or petrol motor cars. So far, however, as the Southern system was concerned, Mr. L. A. Gölsdorf, the chief mechanical engineer, designed a series of light two-cylinder compound locomotives which adequately met the purpose. The success achieved with these engines has induced Mr. Gölsdorf to extend the principle to the working of "station-to-station" stopping trains serving points between the stations at which the express trains call. The locomotives he has provided for this purpose are single driver, two-cylinder engines of curious design compounded on his own well-known system; one of them is shown in our illustration. They are used to haul a train of four light passenger coaches, weighing about 50 tons, at a maximum speed of 50



AUSTRIAN RAIL MOTOR ENGINE.

a cab almost running over him. Cabby pulled his horse up with a jerk and gave his opinion in plain English about absent-minded people.

"Couldn't you see the bloomin' 'oss?" he asked, with a withering glance.

"See it!" gasped Binks, looking contemptuously at the specimen between the shafts. Then he stepped on to the curb. "I didn't see your horse when I stood in front of him," said Binks, "but I can see something when I look at him sideways."  
—*London Tit-Bits.*

#### Yes, Certainly.

A broad minded person is one whom we can convince that our way of thinking is right.—*Anon.*

miles per hour on the level. The fittings are of the usual Austrian type, with the addition of a receiver superheater similar to that used on the Saxon State Railways and a Rihosek spark arrester. The leading dimensions, etc., are as follows:

Boiler—Diameter, 3 ft. 11¼ ins.; height of centre above rails, 8 ft. 0½ in.; pressure, 200 lbs. per sq. in.  
Tubes—Number, 130; length, 8 ft. 2½ ins.; diameter, 1¾ ins.; heating surface, 508.5 sq. ft.  
Superheater—Number of tubes, 16; diameter of tubes, 1¼ ins.; heating surface, 35.4 sq. ft.  
Firebox—Grate area, 10.75 sq. ft.; heating surface, 55.9 sq. ft.  
Total heating surface—596.8 sq. ft.  
Cylinders—H. P., 10¼ ins. x 21½ ins.; L. P., 15¾ ins. x 21½ ins.  
Wheels (Diameter)—Leading and trailing, 2 ft. 10¼ ins.; driving, 4 ft. 8¼ ins.  
Wheelbase—Leading to driving, 11 ft. 5¼ ins.; driving to trailing, 5 ft. 1 in.; total, 16 ft. 6¾ ins.  
Weight—Total, 30½ tons; adhesion, 14 tons.

### Oldest Canadian Locomotive.

We are fortunate enough to be able to present an authentic picture of the oldest locomotive in the Dominion of Canada and probably the oldest on this continent. This locomotive is the "Samson" and is referred to in the chapter on Canada in Angus Sinclair's book, the "Development of the Locomotive Engine," to which the reader is referred for a detailed description of the engine.

We are indebted to Mr. Charles Sibley, the Railway Editor of the Daily Witness of Montreal, for the photograph of this engine from which our illustration has been made, and we clip the following from Mr. Sibley's article on the evolution of the railway train which appeared in that paper September 14, 1907. Speaking of early days in Canada, he says:

"It was in 1836 that the first attempt at working a railway was made in Canada, the St. Lawrence and Champlain, now a part of the Grand Trunk system, being opened in that year. The rails on this line

and had quite a career before it passed to the Intercolonial Railway, on which line it was the first locomotive to be used. This locomotive has been exhibited all over the continent, and has also been on exhibition in England and France, together with a tender shown in the accompanying photograph. The coach is upholstered in white satin and is in a splendid state of preservation. It is about the size of an old-fashioned stage coach, and like one in appearance.

"The engine is a queer piece of mechanism as compared with those in use today. It has perpendicular cylinders and connecting rods; with the old hook motion. One curiosity about it is the fact that the tender was pushed in front of the engine, because the fireman had to feed the monster from the front.

"The main difficulty in those days centered around the locomotive and very little attention was paid to what sort of cars the locomotive had to pull. It is a matter of record that Mr. H. C. Boulier,

various parts of the United States and exhibits them in a sort of locomotive museum. It is to be hoped that the faculties of McGill University at Montreal or the School of Science in Toronto will endeavor to take official charge of the "Samson," not only as a notable Canadian pioneer locomotive, but will preserve it as a relic which will always be of great interest to the railway world, not only on this continent and in the land from which it came.

This engine was at one time the property of the Acadia Coal Company of Stellarton, Nova Scotia.

### Where Tin Comes From.

The first mention of the British Isles in ancient history was that the Phœnician traders went there for tin, which was in demand for domestic purposes ever since the twilight of civilization. That business of carrying tin from Britain began not less than 1600 years before the Christian era. For all the long years that intervened between that period and the present time, the mines of Cornwall produced the principal supply of the tin used in all countries. The supply of tin by the Cornish mines appears to be nearly exhausted, for all the world is receiving much of the tin used to-day from the Straits Settlements part of the East India Islands.

The American consul at Singapore recently reported as follows: The export of tin from the Straits Settlements for the first seven months of 1906, as compared with the same period of 1905 showed that shipments to English ports had increased 33 1-3 per cent., and those direct to the United States had decreased 40 per cent. The total exports of tin for 1906, as compared with 1905, show an increase to English ports of a trifle over 9 per cent., and a decrease in direct shipments to the United States of 12½ per cent. This indicates that during the latter part of 1906 American buyers were gradually increasing their purchases of direct shipments and avoiding the so-called optional shipments via England. The output of tin for the Federated Malay States during 1906 was 48,616 metric tons, against 50,991 tons in 1905. The imports of tin into these States during 1906 was 8,078 tons, and in 1905, 7,628 tons, mostly from Siam and Netherlands India.

### General Foremen, Attention!

Mr. Luther H. Bryan, secretary of the Executive Committee of the International Railway General Foremen's Association, would like to have every member of the association send in present address and title in railroad service and also notify him of any change of address, in the future. Matters of importance are shortly to come before the association, and he desires to be in touch with every member before Nov. 15.



OLDEST CANADIAN LOCOMOTIVE, THE "SAMSON."

were of wood covered with flat bars of iron, and great secrecy was maintained over the first locomotive that was used on it. For some reason the engineer would let nobody see this locomotive, which is one that had been sent out from Europe.

"The trial trip was made in moonlight in the presence of a few interested parties and it was a failure, the 'Kitten,' for that was the name of the locomotive, proving refractory. Several attempts were subsequently made to get this pioneer locomotive to run to St. John, but in vain, and then to the great humiliation of the Canadians they had to call in an engineer from the United States, who promptly diagnosed the trouble. The engine, he declared, was in good order, and all that it wanted was simply plenty of wood and water. This opinion proved correct, for after a little practice, what was then described as 'the extraordinary speed of twenty miles an hour' was obtained.

"The 'Kitten' has long since disappeared in the scrap heap, but Canada is fortunate in possessing what is undoubtedly the oldest locomotive on this continent, namely, the 'Samson,' which was built at Durham, England, in 1837,

who took over the management of the Point Levis and St. Thomas Railway in 1855, used to boast that his line never refused traffic. 'Even when we had only one passenger car on,' he used to say, 'we took butter, eggs, fish, vegetables, sheep, calves and passengers. All went in the car together, a perfectly happy family and no one ever grumbled or threatened to write to the *Times*.' This line is now a part of the Intercolonial.

"The earlier types of railway cars, like the family coach, and those shown attached to the old 'Samson,' were soon to disappear, and the short curves on many lines soon compelled the abandonment also of the four-wheeled car with rigid axles. With the introduction of the bogie or truck, came the lengthening of the car body, with the aisle in the centre, at first with seats along the sides, and then with seats for two occupants in each, at right angles to the sides of the car."

This old historic locomotive, the "Samson," is too interesting and instructive a relic of the past to be let go to the scrap heap and it is to be hoped that it will be taken good care of and suitably preserved. Purdue University at La Fayette, Ind., has succeeded in securing a number of old locomotives from



# Correspondence School

## What Is a Commutator?

By GEO. S. HODGINS.

In the first place the word commutator signifies a device used on a dynamo to change an alternating current into a direct current, the word comes from the Latin *muta*, to change. The very simplest form of dynamo generally has a U-shaped magnet and in front of the two poles or ends of this magnet a coil of wire is made to revolve. Sometimes the coil is placed so as to revolve between the poles of the magnet, and this plan is probably more economical of space.

Suppose for sake of example that the two cylinders of a locomotive represent the poles of a large magnet, the body of which extends back under the boiler toward the firebox. We are, however, only concerned with the ends of the magnet, and we have compared them to the cylinders of a locomotive merely for convenience, as all our readers are familiar with the position of a pair of locomotive cylinders. There is, of course, between the cylinders an open space. In this space the coil of wire may be supposed to revolve.

The shaft or axis about which the coil revolves lies parallel to the axis of the cylinders, and this coil is wound so that it resembles an ordinary slide-valve yoke. The spindle and projecting end represent the shaft of the coil and the yoke represents the coil of wire itself, wound over and under the shaft. As the coil revolves, say from right to left, it is evident that the portion of the coil which is below the shaft moves toward the right hand cylinder and the portion above the shaft moves toward the left hand cylinder.

When the coil is lying flat, that is, as the valve yoke lies when in service, the two outer portions are each respectively as near to the cylinders as they can get, and when the coil stands straight up and down between them, they are as far away from the poles of the magnet as they can be. The illustration of the valve yoke is accurate enough to picture the various positions of the coil as it revolves, but it must be remembered that in a dynamo the coil of wire is insulated from the shaft, and is not all one piece like the valve yoke.

Last month we spoke of the discovery of electrical induction made by Faraday, and in the simple machine of which we are now speaking, with only a single armature coil, the principle holds

good. As the coil revolves, and when the upper and lower portions pass the poles of the magnet, a momentary current flows in one direction round the coil. Let us say, as the upper portion of the coil passes one pole of the magnet a current flows one way in the coil. As this same portion of the coil passes the other pole a current flows in the coil again, but in the reverse way. When the coil is midway between the poles no current flows. This reversal of current in the coil constitutes an alternating current, and electricians write it down as A.C. for short.

In order to get this current off the coil, or off the armature as the coil should be called, it is necessary to provide some means for tapping the coil so

actually parts of the armature. These are called collector rings and are used with the alternating current.

In order to take the currents from the rings it is only necessary to make contacts with each ring by means of a flat strip of copper pressed against the rings and held there at an angle, as a man holds a tool on a grind stone. To each copper strip or brush as they are called, the main circuit wire is attached, and although the collector rings revolve with the armature, the contact of the brushes is constant and the currents induced in the coil wires flow out into and traverse the full length of the main circuit wire as a series of electrical impulses first in one direction and then



ELECTRIC TRAIN ON THE ROCHESTER DIVISION OF THE ERIE.

that the current may be made to flow over a wire circuit, and do work, such as light an incandescent lamp or drive a motor. Suppose that on one end of the revolving shaft of the armature a couple of loose rings are slipped, like the brass neck rings for the metallic packing of a valve stem. The rings in the dynamo are insulated from the shaft but revolve with it, and to one ring an end of the armature coil wire is attached and to the other ring the other end of the wire is attached. We have now two rings, not touching each other, and insulated from the armature shaft, making the finished ends of the wire coil. The intermittent, induced currents reach the rings, as they are

in the other, which constitute an alternating current.

We now come to the commutator, which is nothing more than a modification of the collector rings. The commutator for the simple machine we are considering is in fact one ring cut into two semicircles, which revolve with the armature and the parts are insulated from the shaft, just as the solid collector rings were. The gaps in this commutator ring are filled up flush with the outer circumference of the ring so that the brushes will not snap in and out of the gaps, and so wear away rapidly. When the armature coil stands upright, the gaps in the ring are horizontal, and when the coils lie flat the

gaps are in a vertical line with magnet poles horizontal, as the cylinders of the engine. The contact brushes are so placed that at the moment when the induced current in one direction has died away and before the reverse current has begun, the brushes are upon the insulating substance in the gaps of the ring.

The method of commutating or changing the current from alternating to direct, by means of this ring with the two gaps in it is very ingenious. For sake of clearness let us call the upper part of the armature coil the A portion, and the lower part the B portion, supposing the coil to stand vertical for the moment. As the armature revolves, the A portion is on top at one time and below the next, and so is the B portion. The A and B parts of the commutator ring are also first above and then below, as the revolutions are made.

When the A and B portions of the coil stand opposite the poles of the magnet an induced current flows. Let us suppose that it flows out along the A part of the commutator ring and over the upper main line circuit wire and comes back along the lower main line wire and enters the machine over the B part of the commutator ring, and for sake of simplicity suppose this flow to be in the direction of the hands of a clock.

As the motion of the coil continues and when the A and B portions of the coil are opposite the pole pieces of the magnet, but having made half a revolution the part of the coil formerly at the right is now at the left, a current flows in the opposite direction. In the first case it entered over the B part of the commutator ring, but now, being reversed, it must go out that way. The revolving motion of the armature has by this time brought the B part of the commutator ring in contact with the brush belonging to the upper main line circuit wire and out goes the current over the B commutator ring and over the upper wire, and returns over the lower wire and enters the machine over the A part of the commutator ring, thus maintaining the same clockwise direction of flow as before.

The current has been reversed in direction, but the armature has made half a revolution and so keeps the direction constant on the outside or main line circuit wire. The flow of current is actually reversed in the armature each half revolution, but goes always out over one and the same brush and main circuit wire and back over the other. The piston of an engine pulls and pushes, but the change in the position of the crank pin from above to below the axle at the right time makes the revolution of the driving wheel constant in one direction.

The whole conception of the dynamo here described is that of the most ele-

mentary form of the machine. Such a dynamo would give only a weak current, and even that would not be steady but would fluctuate considerably in intensity. In modern machines the simple coil of the armature which we have considered is repeated very many times until it makes them all together look like a huge rolling pin, but each separate coil insulated from all others. Perhaps four or six electromagnets replace the weak permanent magnet we have described. The increase of parts, however, does not alter the fundamental principle of the machine. All dynamos generate an alternating current, and where a commutator is used the reversed currents are made to flow steadily in one direction, and so produce a direct current (D.C.) over the line wires.

### Elements of Physical Science.

#### VII.—THE MECHANICAL POWERS.

All mechanical contrivances are merely variations of six simple mechanical powers known as the lever, the wheel and axle, the pulley, the inclined plane, the wedge, and the screw.

A lever is an inflexible bar, capable of being moved about a fixed point, called the fulcrum. What is known as the law of the lever is the fact that intensity of force is gained, and time is lost, in proportion as the distance between the power and the fulcrum exceeds the distance between the weight and the fulcrum. It was said of Archimedes that when he saw the immense power that could be exerted with the lever, he declared that with a place to stand on he could move the earth itself.

The wheel and axle is a revolving lever. It will be noted that one application of the lever cannot move a body any great distance, but, by means of the wheel and axle, the action of the lever is continued uniformly and uninterruptedly. As in the simplest form of lever, the wheel and axle creates intensity of force and loses time in proportion as the circumference of the wheel exceeds that of the axle. It is used in a variety of forms, the most common being that of the windlass.

The pulley consists of a wheel with a grooved circumference, over which a rope passes, and an axis or pin, round which the wheel may be made to turn. Pulleys are of two kinds, fixed and moveable, the former has a fixed block. There is no gain of power in the case of a fixed pulley. It is used to change the direction of motion, as in the case of hoisting sails where the sailor, instead of climbing the mast to spread the canvas, stands on the deck and pulling a rope attached to a pulley raises the sails with much less difficulty. The pulley is so cheap and convenient that it is much used in its simplest forms. In complicated systems much of the power is lost by friction, and consequently such systems of pulleys are used

only when large weights are to be raised.

The inclined plane is the fourth of the simple mechanical powers. Any plane surface making an angle with the horizon is an inclined plane. In raising weights the work is facilitated by using the inclined plane, usually in the form of long planks or skids. This simple but useful device was known to the ancients. It is supposed that the Egyptians used it in raising the huge blocks of stone employed in the construction of the pyramids and other buildings. In the case of bodies rolling down an inclined plane, they have a uniformly accelerated motion, and attain the same velocity by the time they reach the bottom that they would have if dropped perpendicularly from the starting point.

The wedge is the fifth of the simple mechanical powers, and the power gained by its use under certain conditions is incalculable. When driven by blows the percussion gives such a shock to the particles of the body that is being penetrated by the wedge that it opens in advance of the wedge. A general law is that the longer the wedge the more easily it penetrates. All cutting instruments are wedges, the angles of inclination differing from each other to suit the material that it is intended to cut or penetrate.

The screw is the last of the simple mechanical powers. It is a continuous wedge and takes the form of a cylinder with a spiral ridge and groove winding alternately round it in parallel curves. The screw consists of two parts, the exterior, or convex screw, in which the ridge and groove are on the outside of the cylinder, and the interior, or concave screw, in which the ridge and groove are on what may be regarded as the inside of the cylinder. These are generally called the screw and the nut. The power of compression produced by a screw is as many times greater than itself, as the circumference of the bolt is greater than the distance between the threads. This increase of pressure can readily be added to by the use of a lever, such as a wrench, enclasp the head of the screw, or nut. The use of the screw is largely in cases where a great and continued pressure is required within a small space.

### Eminent Engineers.

#### II.—ARCHIMEDES.

Alexandria produced another great engineer twenty-two hundred years ago. His name was Archimedes, a Syracusan by birth. A follower of Euclid, he was a most accomplished mathematician, and on returning to his native city he established the science of engineering upon a solid mathematical basis. Under the patronage of the king of Syracuse he devised many engines of war which terrified the Ro-

mans. He was said to have constructed a mirror which set the Roman ships on fire. This feat has been much doubted, but his discoveries in hydrostatics and hydraulics have been much praised. One of his discoveries occurred when the king had set him to find out whether or not the gold which had been given to an artist to work into a crown had been mixed with baser metal. While Archimedes was thinking of the subject he stepped into a bath, and observing the water running over it occurred to him that the excess of bulk occasioned by the introduction of alloy could be measured by putting the crown and an equal weight of gold separately into a vessel filled with water and observing the amount of overflow.

Among his various inventions the water screw became the most popular, and is still known by his name, although it is not now much in use. It was invented for the purpose of removing water from the hold of a large ship that had been built by King Hiero of Syracuse. It consists of a water-tight cylinder, enclosing a chamber walled off by spiral divisions running from end to end and inclined to the horizon. The lower end is placed in the water that is desired to be raised, and the water is lifted in the spiral chamber by the turning of the machine.

Of his extensive treatises on mathematics nine of his books still survive. They treat of the relations of the sphere and cylinder, the measure of the circle, spirals, and the quadrature of the parabola. It may be added that the modern system of logarithms had its origin in the sand counter of Archimedes. It was an ingenious arithmetical numeration applied to reckoning grains of sand. A treatise in wheels and axles also appears among his numerous works, besides a formidable dissertation on the engines used against the Romans at the siege of Syracuse. In spite of the clever devices used by Archimedes in defending the city it was finally taken by Marcellus in 212 B. C. It was said that while the eminent engineer was engaged in some engineering problem and quite oblivious of the general massacre which followed the fall of the city, he never moved when a Roman soldier approached, and struck him with a gladius. Marcellus, in the midst of his triumph, mourned the death of the great man. His tomb was marked by the figure of a sphere inscribed in a cylinder, the discovering of the relation between the volumes of a sphere and its circumscribing cylinder being regarded by Archimedes as his most valuable achievement. The perpetuation of that facts forms an artistic and appropriate decoration on his tomb.

## Questions Answered

(93) J. D., New York, writes: What is the average lift of a safety valve?—A. A very good average may be taken as from 5 to 7 one-hundredths of an inch at 200 lbs. pressure.

### PRESSURE ON SAFETY VALVE.

(94) J. D., New York, asks: If there is 100 lbs. pressure on a boiler, what is the pressure on the under surface of a 2-in. safety valve? A.—The area of a 2-in. circle is of course 3.1416 ins. according to the table of areas of circles, which may be found in any engineering pocket book. The pressure exerted on the valve would be 314 lbs.

### LOW WATER EMERGENCY.

(95) J. D., New York, asks: If a boiler has 100 lbs. steam pressure, and the water is below the gauge cocks how can the steam be got safely out of the boiler?—A. The fire should be dumped out at once and steam can then be blown out of the whistle. This can be readily done by putting a piece of waste in the bell of the whistle, so as



SAINT MARY'S VIADUCT, CHAMOUNIX.

to prevent it making its ordinary sound. Both injectors can be put on and let work as long as they will, and the steam pressure will go down rapidly and safely.

### STRENGTH OF BOILER.

(96) J. D., New York, asks: (1) What is the safe working pressure of a boiler 60 ins. in diameter, and (2) of a 48-in. boiler, both with sheets  $\frac{3}{8}$  in. thick and having a tensile strength of 60,000 lbs. per sq. in.?—A. From the data supplied only an approximate answer can be given. Consider a strip of this boiler 1 in. wide all round. This forms a circle or hoop. The lower half of the hoop is, when under pressure, pulling down from the upper half, and the upper half is pulling up. The tendency to separate is resisted by the metal of the sheet which on each side measures  $\frac{3}{8}$  of an inch thick by 1 in. wide. Both together give a total section of  $\frac{3}{4} \times 1$  in., or  $\frac{3}{4}$  of a square inch. The tensile strength of 1 square inch is given as 60,000 lbs., therefore  $\frac{3}{4}$  of a square inch would have a tensile strength of 45,000 lbs. Supposing that

the joints of this boiler are only three-quarters as strong as the sheet, we take  $\frac{3}{4}$  of the 45,000 lbs. already found, as the ultimate strength of the sheets. This is 33,750 lbs. Now, taking a factor of safety of 5, we find that the available strength of the sheets becomes 6,750 lbs. The pressure on a boiler is calculated, as if acting upon the diameter, which in this case is 60 ins. long and 1 in. wide, the width of the hoop we are considering. The area, therefore, upon which the pressure is applied tending to separate the upper and lower half hoops of the boiler is 60 ins. by 1 in., or 60 sq. ins. The available pressure is as we found 6750 lbs., and the pressure on 1 sq. in. is the sixtieth part of this or 112 $\frac{1}{2}$  lbs. (2) The safe pressure on the 48-in. boiler is found in the same way and is just about 140 lbs.

### NEUTRAL AXIS OF A PLATE.

(97) J. L. S., Pueblo, Col., writes: In the *Boilermaker's Assistant* the author states that for the circumference of boiler or other plate cylinder you multiply the inside diameter, plus the thickness of the plate by 3.1416. Thus, for a cylinder 24 ins. inside diameter made of  $\frac{1}{4}$  in. plate the circumference from centre to centre of rivet holes equals 76.1838 ins. or  $24\frac{1}{4} \times 3.1416$ . Mr. C. E. Fourness in the April, 1895, issue of *LOCOMOTIVE ENGINEERING*, gives the circumference as 3 1-7 times the inside diameter, and to this he adds the thickness of the plate. Which is correct and what is the correct method to use on elliptical pipes or boilers?—A. The object of the method to be employed is to get at what is called the neutral axis of the sheet. When a sheet is curved the upper half of the plate is slightly extended and the lower half is slightly compressed. At exactly the centre line, or half way through the thickness of the plate, there is no extension or compression and this line remains of the same length whether the sheet be straight or curved. When the sheet is curved so as to form a circle the inside diameter plus twice the half thickness of the plate is the line of the neutral axis. In other words, it is the inside diameter plus the thickness of the plate which has to be multiplied by 3.1416. The rule you quote as given twelve years ago by Mr. Fourness was probably a printer's error, as his rule properly stated should be the inside diameter plus the thickness of the plate multiplied by 3 1-7. It so happens that 1-7 very nearly equals .1416, and for practical purposes they may be said to be equal.

When dealing with an ellipse the same principle should be followed; the neutral axis of the ellipse is the line of unchanging length. The rule is, take

half the longest diameter and add it to half the shortest diameter of the ellipse, add to these the thickness of the plate and multiply by 3.1416, as in the case of the circle. That is the way some engineering pocket books state it, but more concisely the rule is, take the long and the short diameter, add them together, divide by 2, then add thickness of plate and multiply by 3.1416.

#### POSITION OF GREATEST POWER.

(98) A. M. L., Sydney, Nova Scotia, asks: (1) In which position has a locomotive most power, with crank pin on the top, or on the bottom quarter?—A. For all practical purposes the engine has about the same power in each of these positions, but if you desire a greater degree of accuracy you can calculate the pressure on the piston exerted by the steam when the pin is on the lower quarter. The full area of the piston should be used, as the steam is between it and the front cylinder cover, that is, assuming the engine to be going forward. With the pin on the top quarter and steam is between back cylinder cover and piston, the area of the piston-rod must be deducted from the area of the piston upon which the steam acts. This will give a slightly smaller available piston area, and consequently a slightly lower total pressure on the piston.

(2) In running forward, on which shoe of the driving box, the front or back, is the most pressure exerted?—A. The most pressure will be on the back shoe, for the reason given above, besides, the fact that the force of the piston is exerted backwards while the engine is running forward it is pushing against the acquired momentum of the engine.

#### TROUBLE WITH HIGH SPEED GOVERNOR.

(99) J. W., Kenora, Ont., writes: What I want to know is about the high speed governor on one of our 600 class; she works like this with G 6 brake valve handle in running position. We get 90 lbs. in main reservoir and 70 in train pipe, and that is low pressure. Now we put brake valve handle on lap and pump starts again and pumps up to 110 lbs., couple up to train with handle in running position. Air feeds into train pipe till it shows 45 lbs., then the pump starts again slowly and then gets a little faster by placing the handle about 5-16 in. nearer to release position. I can get full speed out of the pump or on lap till I get 110 lbs. high pressure. Another engineer came to me with the same complaint. We changed brake valve lately on his engine, a leaky rotary, but first I changed pump governor and slide valve feed valve attachment and it is the same yet. Until lately we have had the duplex governor and now we have the one with a 20 lb. spring on top to regulate the 90 lbs. Why does

it act this way?—A. It seems from your remarks that the low pressure portion of the pump governor, which operates only with the brake valve in running position, has a leaky pin valve tending to throttle down the supply of steam to the pump with the brake valve in running position. By placing the brake valve handle 5-16 in. from running position towards full release position would close the brake pipe feed port in the brake valve, having the same effect upon the pump governor as placing the brake valve handle upon lap position. Then the pump would continue to work until shut off by the main reservoir control portion of the pump governor at 110 lbs. main reservoir pressure in this case.

#### New York Railroad Club.

The opening meeting of the New York Railroad Club for the season was held in the Club's new quarters in the Engineering building in West 39th street, New York, on Friday evening, September 20th, Vice-President Mr. W. G. Bessler presiding. The feature of the evening was the presentation of a paper by Mr. Max Toltz on "Steam Locomotion versus Electric Locomotion." The paper was largely a reply to a paper that had been presented before the American Institute of Electrical Engineers some months ago on "The Substitution of the Electric Motor for the Steam Locomotive," and Mr. Toltz presented an array of figures showing the many errors into which some electrical engineers willingly or unwillingly fall when discussing the respective merits of steam and electric locomotives. Mr. Toltz's estimates were based on the locomotive tests made during the World's Fair at St. Louis, which established the fact that the coal consumption per draw bar horse power per hour was less than two and half pounds. Other expenses of repair and maintenance raised the total cost of steam locomotive operation to nearly six cents per horse power per hour with coal at three dollars per ton. Mr. Toltz argued at considerable length that the consumption of fuel could be much lessened by the general adoption of superheated steam in locomotives. He illustrated several methods of superheating and paid a warm compliment to the Canadian Pacific, which road he said had demonstrated the fact that a saving of coal amounting to 15 per cent. had been accomplished by superheating.

Mr. Toltz presented a superheating device of his own invention which, he claimed, would effect a still further saving. The apparatus was of the smoke flue kind of superheating and had some novel features which deserve attention, the most notable being the introduction of flattened instead of circular pipes. It will be readily observed that the process of heating steam to a higher degree is more

easily accomplished when the steam is in thin flattened receptacles than in large circular pipes.

Water heaters and smoke consumers were also pointed out as methods of further economy in the steam locomotive and Mr. Toltz claimed that a saving of thirty per cent. could be effected in the expenses of locomotive running.

Turning to the use of the electric locomotive Mr. Toltz stated that he had carefully investigated some of the greatest water power sources in America, and under the best conditions none of them could be utilized into electric energy per draw bar horse-power per hour at less than five cents. The steam locomotive can easily do better than this, and while the electric locomotive, either in single or multiple units, has its place in big terminals and in tunnel operation, it cannot in its present development replace the steam locomotive for trunk-line service.

Mr. E. W. Storer and Mr. L. B. Stillwell defended the claims of the electric engineers and prophesied a reduction of expenses when all roads are electrically operated. Mr. C. A. Seeley spoke very ably in defense of the steam locomotive and assured the members that there would be no general electrification of railroads in our day. The electric motor had become a necessity in large cities and congested districts and for short distances it had many advantages, but the advantages were very costly and could not be entertained on long distance traffic.

Mr. J. E. Muhlfield, Superintendent of Motive Power of the Baltimore & Ohio Railroad, presented the strongest and most convincing argument in favor of the steam locomotive. His array of facts and figures in connection with the running of various kinds of steam and electric locomotives covering several years and under similar conditions showed that the cost of electric operation was more than twice that of similar service rendered by steam locomotives. The advantages of the use of electricity in lighting and in short distance running in thickly populated districts were apparent to everybody, but in transportation service on American roads over thousands of miles of variable hill and valley in every kind of climate the electric motor could not compete successfully with the steam locomotive. He admitted that electric locomotives could be operated at from 50 to 60 per cent. efficiency, and that degree of excellence could not be achieved in steam locomotive practice, but he showed that we can get from 50 to 55 per cent. efficiency with steam locomotives on level track and when a uniform rate of speed is maintained. Mr. Muhlfield contended that steam and electric locomotives were both capable of much further improvement, but there was no apparent likelihood of electric motors taking the place of steam locomotives to any considerable extent.

# Air Brake Department

## What the Engineer May Do.

He may in a few spare moments while oiling around and looking over his engine for the trip do a great many little things to save trouble on the road and maintain a general good condition of air brakes on his engine.

For instance, he may oil the pump and swab, which will prolong the life of the pump. In the event the pump is a Cross-compound pump the proper lubrication will save a possible case of its stalling on the road, and with either pump avoid overheating and the cutting of the air cylinder. Then drain the main reservoirs of water, which will avoid frozen triple valves, air hose, etc., in the cold weather; also the brake valve will be more likely to work easy and give less trouble generally when this is done. Nuts, bolts and pipe unions which he may notice are loose on his tour of inspection preparatory to his run, may be tightened, consuming only a minute or two.

While the foregoing may seem unreasonable and insignificant to some, it will be found from experience that it is the little trivial or insignificant things that gradually grow into large and difficult trouble when neglected in their beginning. Further, any engineer will agree that a good run without detention or failure is much to his credit and very much appreciated by his higher officials even though he is able to shift the cause or responsibility on to some one other than himself.

## Difference in Brake Pipe Pressure.

There has always been considerable discussion afloat concerning the difference between low and high brake pipe pressures, so many maintaining that if the brake pipe pressure be higher a correspondingly higher brake cylinder pressure would result from the same brake pipe reduction of less than a full service. We know that when a 10 lb. reduction in brake pipe pressure is made that the triple valve is so constructed as to allow 10 lbs. of air to flow from the auxiliary reservoir into the brake cylinder, resulting in a brake cylinder pressure dependent upon the piston travel, and then close the service port in the slide valve of the triple and not allow any more air to flow from the auxiliary reservoir into the brake cylinder until a further reduction in brake pipe pressure is made. Therefore, it makes no difference in brake cylinder pressure if a certain amount of air comes from an auxiliary reservoir pressure of 70 lbs. or

110 lbs. From the foregoing it seems that it is the amount of reduction in brake pipe pressure that controls the brake cylinder pressure and not the amount of brake pipe pressure maintained, when any reduction in brake pipe is made less than an amount necessary to equalize the pressures between the auxiliary reservoir and brake cylinder.

Although, the stopping effect of the brakes from a 10 lb. reduction in brake pipe pressure of 110 lbs. may be greater or

less, the application of the brakes on the cars impossible from the engineer's brake valve when the defective angle cock is the one at the rear of the tender, and there it is more probably found, on account of more vibration there than upon the cars. It ought not be necessary here to go into detail concerning the results from failure to obtain a needed emergency application of the brakes.

## The H6 Brake Valve.

Editor:

A new engine and tender brake equipment, manufactured by the Westinghouse Air Brake Co., has appeared on a number of locomotives built recently.

The appearance of the brake is similar to the E. T. brake equipment, but the ports through the various valves are arranged differently and the valves are not interchangeable with those of the original E. T. brake. The symbol H 6 is stamped on the automatic brake valve, on the independent brake valve S 6, and on the distributing valve No. 6. The operation of the brake is practically the same as the E. T. brake and has the same driver brake holding and independent application features.

Two duplex air gauges are employed—the red hand of the standard gauge registers main reservoir pressure, the black hand equalizing reservoir pressure; the red hand of the smaller gauge registers brake cylinder pressure and the black hand brake pipe pressure.

The safety valve screwed into the distributing valve is of an improved type, and the cut-out cock to the brake valve is placed in the reservoir pipe.

The distributing valve reservoir has the usual pipe connections; the independent brake valve has four—one to the automatic brake valve; one to the exhaust port of the application chamber of the distributing valve; one to the application chamber direct; through the other it receives its supply of air from the reducing valve, which is same as the B 3 reducing valve, except that air flows through the supply valve instead of past the end, which gives a better wearing surface on the valve seat, creates less friction and retains its lubrication better.

The H 6 brake valve pipe bracket has the same connections as the H 5, with the exception of the double heading pipe. An additional pipe branches off from the application chamber pipe and connects to the brake valve; in this pipe there is a non-return check valve.



AVOCA BRIDGE FROM ABUTMENT AFTER EXPLOSION OF DYNAMITE.

quicker to take effect than from the same reduction in a 70 lb. brake pipe pressure, since there is more pressure to force the 10 lbs. into the brake cylinder in one case than in the other, but the resulting brake cylinder pressure will be no greater.

## Defect of the Angle Cock.

The angle cock, as a rule, does not give much trouble; therefore, it is not likely to receive much attention, although the neglected angle cocks get in their bit of air brake trouble at times. The continual vibration that the angle cock is subject to, especially when the brake pipe is loose, will wear the handle and plug until sufficient lost motion between these parts will be created to make it impossible to entirely open the port in the plug when the handle of the angle cock will be turned to the open position as far as possible. This restriction of opening in the brake pipe, if sufficient, will render an emerg-

The cut-out cock for the H 6 valve is the Penna. R. R. standard cut-out cock; the brake pipe exhaust port of the brake valve is piped to the small end of this cock and a connection to the brake pipe is made from the large end.

The supply of air for the brake pipe feed valve is taken from a point between this cock and the brake valve, so that when this cock is closed it cuts off all pressure from the brake valve and opens a communication between the brake pipe, the feed valve pipe, and the valve body of the brake valve, and at the same time closes the brake pipe service exhaust port. When double-heading the cut-out cock under the H 6 brake valve should be closed on the second engine and both brake valve handles placed in their running positions. As the brake valve is still connected with the brake pipe, the gauges will show at all times the pressure in the brake pipe, and the brake on the engine and train can be applied by moving the valve handle to emergency position.

The independent brake can be applied or released at any time regardless of the position of the equalizing valve.

With the brake valve handles in their running positions the exhaust port of the application chamber of the distributing valve is open to the atmosphere by the way of the independent brake valve and the emergency exhaust port of the H 6 brake valve. When the S 6 brake valve handle is placed on lap position all ports are blanked, and when placed in application position, air from the reducing valve will flow into the application chamber of the distributing valve, and, if the equalizing valve is in release position, it will pass through its exhaust port and back as far as the S 6 rotary valve seat. When the handle is returned to running position, the pressure will escape through the exhaust port of the H 6 valve.

If the equalizing valve is in application position when the S 6 valve is used, it will remain applied when the handle is again placed in running position, until the brake pipe pressure forces the equalizing valve to release position or the independent valve handle is placed in release position, when the application chamber will be emptied through the independent brake valve exhaust port.

From this it will be seen that the brake will be applied with both brake valve handles in their running positions, if the brake pipe is overcharged and a few small leaks exist, consequently there will be some complaints of brakes "creeping on" from those who handle the brake without regard for the proper positions of the valve handles. The H 5 brake will not apply under these conditions, as the application chamber would be open directly to the atmosphere and the flow of air from the pressure chamber would be free to escape.

The pipe which connects the train line

exhaust to the cut-out cock under the H 6 valve should be tested for leaks occasionally by closing the cock and making a service reduction; the object of this arrangement is to prevent a loss of brake pipe pressure when double-heading.

The rapid increase of brake pipe pressure during train brake release is likely to force the brake valve equalizing piston of the second engine from its seat, and it would be a difficult matter to get the piston to seat without opening the cock and admitting main reservoir pressure to the brake valve. The pipe connected to the large end of the cock admits brake pipe pressure, which, assisted by spring pressure, holds the plug valve to its seat. Should this pipe on the leading engine break off, the brake pipe leak can be plugged and a blind washer inserted in the union connection at the cock; should main reservoir pressure force the valve from its seat, the pressure will equalize instantly and the spring again seat the valve.

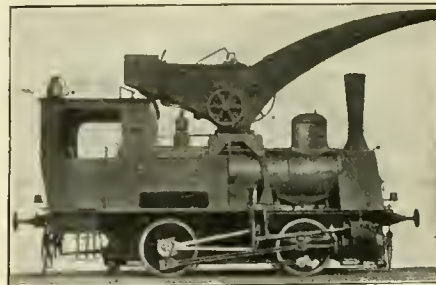

A KRUPP CRANE TANK ENGINE.

Should the pipe break off on the second engine, the brake pipe leak can be stopped and the handle on the cock turned to a position half way between open and closed, and a wedge driven between the handle and the body to hold valve to its seat. In this position all three ports in the cock will be blanked, and as the valve handle is in running position, air will flow through the ports in the brake valve to the feed valve pipe and feed valve, unseat the supply valve and flow through the reservoir pipe to the top of the rotary valve.

Under ordinary conditions when the H 6 brake valve is placed in release position air flows from the main reservoir, to the brake pipe and equalizing reservoir, from the main reservoir to the low pressure governor top and from the feed valve pipe through the warning port to the atmosphere. If an application has been made previously, air will flow from the distributing valve as far as the rotary valve seat. In running and holding positions, air flows from the feed valve pipe to the brake pipe from the main reservoir to the low pressure governor top and from the brake pipe to the equalizing reservoir.

When in running position, after the brake has been applied, air will flow from

the distributing valve to the atmosphere. On lap position all ports are blanked and when placed in service position, the equalizing discharge valve and reservoir control the flow of brake pipe pressure, same as all other Westinghouse brake valves.

In emergency position air flows from the brake pipe to the atmosphere, from the equalizing reservoir to the atmosphere, and from the feed valve pipe to the application chamber of the distributing valve through the non-return check valve.

The distributing valve has the same stop cock arrangement for cutting out tender driver brake and truck brake cylinders. The stop cock for cutting out the distributing valve is located in the supply pipe. The pipe connecting the brake valve with the distributing valve is used for the same purpose that the retaining valve pipe is used with the ordinary triple valve, therefore it should not be plugged if accidentally broken.

If the application chamber pipe is broken the application chamber can be plugged and the independent brake cannot be applied.

Washington, D. C. G. W. KIEHM.

#### Erosive Action of Steam.

Not long ago the Hon. Charles A. Parsons, at a meeting of the Royal Institution of Great Britain, showed an enlarged photograph of a hardened steel file of square section, which for 145 hours had been exposed to the action of a jet of steam at 100 pounds pressure discharged into a condenser with a pressure of one inch, absolute, of mercury. The cutting action of the jet upon this extremely hard material was very remarkable. The file was smoothed down where the steam had passed over it, while the teeth on the other parts of the file were as they had come from the manufacturer.

In speaking of the erosive action of steam Mr. Parsons said, "It has been shown by experiment that if drops of pure water arising from the condensation of expanding steam impinge on brass at a greater velocity than about 500 feet per second, there results a slow wearing away of the metal. It is very slow and would require about ten years to erode the surface to a depth of one thirty-second of an inch. In the compound turbine the striking velocity is much below this figure."

One of the pioneer railroads constructed in New Jersey was the Jersey City to Paterson now used by the Erie. When the chief engineer engaged in the survey of this railroad made his first report to the directors, he informed his employers that he had introduced several reverse curves in the location for the sake of their graceful and picturesque effect.

# Patent Office Department

**MACHINE FOR FACING VALVES.**

Mr. T. B. Williams, Orange, Mass., has patented a machine for facing valves, No. 865,739. As is shown in the illustration, the machine embodies clamping means for engaging a valve

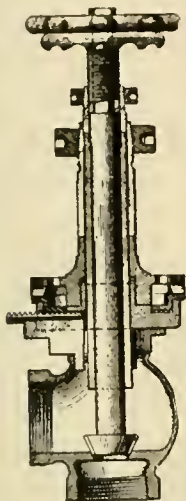

VALVE FACING DEVICE.

casing, a rotatable spindle having a cutter extending beyond the clamping means. There is a bearing surrounding and supporting the spindle near both ends and having a cylindrical external journal surface, and means for fastening the bearing in a stationary position during the advance of the spindles.

**INDICATOR.**

Mr. S. T. Park, Danville, Ill., has patented a draft or work indicating and recording mechanism for locomotives, No. 865,931. The device embraces a combination with a draw-bar and a locomotive, or other motor, of a fluid pressure cylinder connected to the locomotive, or motor, of a piston working in the cylinder and connected to

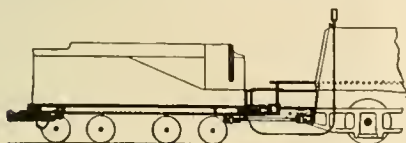

RECORDING MECHANISM.

the draw-bar. A pressure gauge communicating with the fluid cylinder is attached, furnished with a clock mechanism. A movable holder for a record sheet is actuated by the clock mechanism and a recording arm is connected with and actuated by the pressure gauge.

**STEAM BOILER.**

A steam boiler has been patented by Mr. K. H. Merk, Halensee, Germany, No. 866,291. The device embraces a steam boiler built in two sections with a superheating chamber located between the sections of the tubes and vertical superheating tubes in the

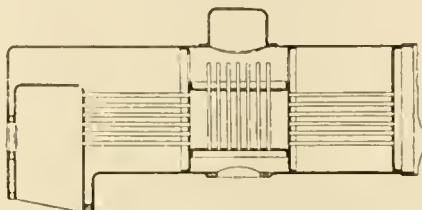

STEAM BOILER WITH SUPERHEATER.

superheating chamber whose entrances extend beyond the water level of the boiler, the exits being located in the bottom plate of the superheating chamber.

**CROSS-HEAD.**

An improved form of cross-head has been patented by Mr. E. T. James and Mr. G. W. Webb, Charlotte, N. C. No. 866,655. The cross-head is furnished with a pair of transversely extending seats at the top and bottom thereof and open at opposite sides of the cross-

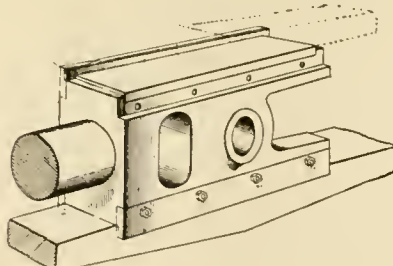

NEW FORM OF CROSS-HEAD.

head. There are shoulders arranged at the end of each seat, and a wear plate fitted into each seat and co-operating with the shoulders to prevent relative longitudinal movement between each wear plate and the cross-head. There are also independently removable locking strips that prevent relative transverse movement of their respective wear plates.

**FEED-WATER HEATER.**

Mr. S. A. Morgan, Indianapolis, Ind., has patented a feed-water heater, No. 861,667. The combination embraces a locomotive boiler having a front smoke arch or box, and a dividing wall separating the smoke arch into upper and lower compartments. There is draft chambers situated on each side of the

boiler, which is divided into upper and lower flue ways, the upper flue-way being connected to the upper compartment of the smoke arch, and the lower flue-way being connected with the lower compartment. There is an independent series of feed-water heating pipes situated within each of the flue-ways and a collecting drum situated

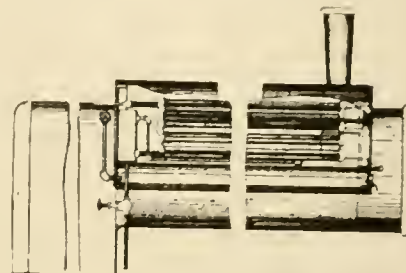

HEATER FOR FEED WATER.

between each of the series of heating pipes and the boiler, and means for supplying feed-water to each of the series of heater pipes.

**SCREW-SEAT VALVE.**

Mr. C. M. Hose, Indianapolis, Ind., has patented a screw-seat valve, No. 865,392. It comprises a valve body having a screw-threaded opening to form a valve-seat, and a stem having an annular flange adapted to be seated on the valve seat, the stem having a screw-threaded tapering end below the flange to screw into the threaded seat and form a closure, the extension be-

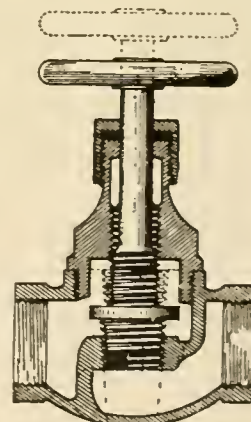

VALVE WITH SCREW SEAT.

ing recessed from its end to form walls of the same thickness as the walls of the valve seat. The valve body has a recess to form a seat for the flange when the valve is open to assist in preventing leakage around the stem.

### Traveling Engineers' Association.

#### DISCUSSION ON SMOKE PREVENTION.

(Continued from page 486.)

lump as large as your head you are going to be checked for black smoke. We have about ten inspectors in the district that just watch the conditions, distributed along the road in the District of Columbia, and if an engine makes three or four exhausts with colored smoke it is checked as smoke against that road, and we have been able to get down to about one-half of 1 per cent. of the engines handled in the district making colored smoke.

About two or three months ago I had an opportunity of viewing a test which was being conducted at Altoona with a view of eliminating smoke. They were running briquettes, and as near as I could find out, run of mine coal as compared with briquettes made from the same grade of fuel. The small briquettes showed a saving in smoke of about 50 per cent. The larger briquettes, made about the size of an ordinary briquette, eliminated the smoke about 75 per cent. I attributed that to the more air coming in through the briquettes, although it was found to be more extravagant on account of the outside of the briquettes sealing off and piling up in the front end. That was about 50 per cent. more with the large briquettes than with the small.

I notice Mr. Lynch speaks of the uniform size of coal as being very important in eliminating smoke. That is the reason I speak of the briquettes. They are all of one uniform size and consequently they can be fired level, and you get the same amount of air through the different parts in your fire box and you can keep the smoke down very successfully, where you can not with the same grade of coal, firing with the run of mine coal.

I do not think it is possible to eliminate black smoke with a soft coal burning engine altogether. You can get on an engine and instruct a fireman to fire with one shovelful of coal each time, close the door after each shovelful. He will do it while you are on the engine. You know yourself that you are telling him to do something that you would not do if you were firing that same locomotive, especially with the heavy power that we are using at the present time, where we are on the road from twelve to twenty-four or thirty-six hours. I think that it is very necessary that we should go into some method of opening and closing the door for him. Right on those lines is where we should experiment further. I think the automatic stoker and automatic fire door opener are both appliances that must come into use sooner or later.

Mr. Angus Sinclair: I probably have devoted more attention, more study, more experiment, to smoke preventatives than any one in this country, perhaps in any other country. I went into the railway service in the locomotive superintendent's

office just at the time that they were beginning to experiment with coal burning in Great Britain. This locomotive superintendent was impressed to apply a brick arch to locomotives, and his invention with the arch and means of supplying air above the fire became the really efficient method of smoke preventing in Europe, and it is so used to-day, and there is no other method of preventing smoke that has been so successful or has met with so much application. My experience has been that with light locomotives, comparatively small fire boxes, and coal that was not very rich in bituminous compounds, smoke could be entirely prevented if the fireman was careful in doing his work. There are three important elements in connection with successful smoke prevention. There is the method of throwing the flame back so that it mixes with the oxygen, which is usually done by the brick arch, also the method of admitting the air above the fire; the other is the careful fireman. Without the careful fireman it does not matter what kind of devices you have; it does not matter what smoke prevention appliances are put into the fire box; you will always have smoke unless he co-operates with the device he has in use.

About 1860, I think it was, when they began using soft coal, changing from wood to coal, in this country. There were a great many patented devices, patented fire boxes, patented boilers, all sorts of devices, gotten out to prevent smoke. I know I have a record of over 200 smoke preventing devices for locomotive boilers. In a book which I have recently published on the Development of the Locomotive Engine I have illustrations of something like twenty smoke preventing boilers, smoke preventing fire boxes and boilers combined—thoroughly satisfactory, as long as the fireman does his work properly.

So it comes to a great extent to be the work that the fireman does that gives you elimination of the smoke and gives you clean trains and a clean atmosphere.

I was unfortunate enough some years ago to be invited to Cedar Rapids to witness some tests of methods of smoke prevention that they were following with the engines on the Burlington, Cedar Rapids & Northern Railway. I went there in good faith and saw what was done and I described the process. I described what was done; took no side in it; except merely a descriptive part, and I published the results of that in *LOCOMOTIVE ENGINEERING*. I lost about 3,000 subscribers for that attempt to educate enginemen and others. That was the punishment for urging the enginemen of this country to do their work properly; and I am sorry to say that the sentiments against me and my publication on that account were in many instances supported by the traveling engineers, who sympathized with the men

in their opposition to the methods of doing the work properly. These are facts, and I am sorry to say that I have to tell such facts, but the remedy is coming. I had to suffer and my interests had to suffer, for my advocacy of sound principles in firing, but I notice now that the principles enunciated then have been influencing many of the railroads in the country, and now to-day, or since I came to Chicago, I have watched engines that are working here and there is not a tenth of the black smoke to be seen that there was before this campaign commenced; so that the principle is making progress, and if you gentlemen take it up earnestly and state what can be done and give it your thorough support and get the support of your officials, there will be very little black smoke to complain of.

When I talk of there being little black smoke, I am aware that with certain kinds of coal and with a plain fire box it is impossible for the most skillful fireman that ever wielded a scoop to prevent some, and with some coals a great deal of smoke; but with the ordinary coal that is not very rich in hydrocarbons, there will be sufficient prevention of smoke to prevent the public authorities and the people of the United States from complaining of the contamination of the air of the country and the cities from smoke coming from the furnaces of locomotives. (Applause.)

Mr. L. M. Carlton (C. & N. W.): I have charge of eighty-five switch and transfer engines in the city of Chicago. I am in the hotbed between the officials of the city, the officials of the North-Western Railroad and the men. I had a notice from our superintendent of motive power and machinery to-day stating that on such and such a day, at such and such an hour, engine number so-and-so emitted dense black smoke at 10:45 A. M. We get those frequently, and you all know what the penalty is in the city of Chicago for making unnecessarily black smoke. The city is making a campaign against the railroads and for the benefit of the public; and we are all the public, and we can not blame the public for making the complaint. The North-Western road has made several attempts to eliminate black smoke.

In the worst districts they furnish Pochontis smokeless coal. They mine their own coal, and they wish to use it, and they want it used successfully, if possible.

Now my idea of this smokeless question is this: to get rid of the smoke you have got to burn it up. The best way to do that is what we are after. First of all we must have the engines in good condition. That includes clean boilers—I refer to washing out—clean flues; we want to see the flues are bored out every time the engines come in the house and have been lying in for any length of time.



Then we want to look after the waste of steam that is getting away from us through the different kinds of leaks. We ought to have a good blower and some combustion tubes in the fire box. We ought to have our fires cleaned before they get clinkered up so that no air can get through them. I am a great believer in the arch, because it retains the gases in the fire box longer and gives a chance for the heat to burn up the gases more thoroughly. Out of those eighty-five engines we have about seventy of them equipped with arches. Fifty of these are of the hollow type—hollow arches. I have three engines equipped with an addition called the crown arch. This crown arch makes a contraction between the end of the hollow arch and the back sheet of the fire box and the gases pass up through this contracted opening about fifteen inches clear across the box, mixing the air that goes through the fire box with the gases and smoke flame, and the result is the smoke is burnt up. I was on two of the engines yesterday morning before I came over here to the convention, and kept track of them. Day before yesterday I rode one of them for eight or nine miles on a transfer, and I never saw as clean a stack in all my days of railroading as I saw on that engine. The engine burned considerably less coal. The engineman was pleased and so was the fireman, and the pointer stood right up to the popping off point, very close to blowing off.

Now, as Mr. Sinclair says, with all the devices that you want to place on an engine, you have got to have some assistance from the fireman, and I will include the engineman too. The fireman ought to fire somewhere near right and the method that we advocate is to fire one side of the fire at a time, having a bright side of the fire to burn the smoke as it rises off the other side. This method can be carried out with light or heavy service, firing from one to four scoops of coal at a firing. If the work is heavy, put on three or four on a side, leaving the other side of the fire bright all the time; alternating, so to speak.

I say you must have the assistance of the engineer in connection with this. I got on with one of our men not long ago and he did not hook the engine up inside of half stroke. He had the injector lazy cock wide open, and I wondered where the steam was going to. Black smoke was rolling out, because the fireman was trying to keep up with the injector. I very quickly found out where the trouble was, and they thought I was finding a little too much fault when I suggested that the engineman ought to work with the fireman.

We have twenty-two grades of coal delivered to us at one chute or one point, having to have the coal come from different places to meet our demands. They

have passenger coal and freight coal, and they put any old kind of coal on the switch engines, and we have got to do good work with it if we can. When it comes down to black smoke that occurs through carelessness, we hold the engineman and the fireman responsible. We expect the engineman to complain of the fireman if he does not do his work. As long as he does not complain and lets the fireman be careless we hold the engineman with the fireman for allowing him to be careless.

Mr. Buell: Along the lines Mr. Carlton was speaking, I thought it might be interesting to tell of some tests that I had the privilege of making on some engines that were equipped without an arch and then were equipped with these hollow brick arches that Mr. Carlton speaks of. In each test we kept a record of the number of minutes that the black smoke showed at the stack, and while I do not remember the exact figures, we found that the time during which the black smoke showed at the stack with the hollow arch applied to the engine was 50 or 60 per cent. in favor of the hollow arch. It certainly is a device on passenger or freight engines where you are troubled with the smoke nuisance it will pay you to look into.

The same fireman fired the engine in both cases. They took the engine first without any arch and then with; kept the same crew. There were eleven, twelve and thirteen cars where the tests were made, and we found that the fireman kept a little lighter fire with the arch for the simple reason that they increased the size of the nozzle with the arch because the engine steamed so much more freely. The smoke was just one of the features. I only mention one. It was a saving all around in steaming qualities and amount of fuel burned, which allowed a lighter draft on the fire.

Mr. James S. Downing (Southern): Mr. President and members, we will take it for granted that the engine is properly drafted to do this work. The size of the nozzle cuts a good deal of figure. You take chain gang engines, the best engine on the road must be reduced so that the poorest fireman and poorest engineer can make steam and get over the road.

Next to that is an overloaded engine. We can not expect an overloaded engine, either in passenger or freight service, to do the work that an engine with a moderate load would do. Next is the best kind of coal ordered for the fireman to handle. He will have less work. There is no use talking of making every man a fireman or an engineer any more than a doctor or a lawyer. He can be taken so far, just the same as the monkey; you can take him so far and then he quits. You can take a man in law and he is good at this or that or the other, and no more. The same way with the engine

crew. Then furnish the best grade of coal you can get. Prepare it for him. You should not have a roundhouse and a yard three or four miles apart when probably half a mile is what you need. Take the modern batt' ship. She is equipped with the best appliance that can be had. Next to that you must educate the fireman up to take care of the fire when the fire is cold. When he comes on he must see if he has fire enough to spread to cover his grates. If not, let him make it up gradually. If he has clinkers, let him shake his grates and remove them. Then build up the fire.

The trouble I have had with the fireman is to teach him that it is absolutely necessary to admit air above the fire. I have never had experience with any of the smoke consumers, but open the fire door damper and leave it open. That admits air above the fire. I had experience with a small engine, had to run to schedule thirty-five miles an hour, pulling two sleepers, a heavy day coach and a heavy baggage car, with nine stops in 154 miles, and by educating and working with the firemen I brought the coal consumption down from twenty-two miles to the ton to twenty-six and three-tenths miles to the ton, and did that in about sixty days' working with the firemen.

But you can not get the results all out of the firemen and the engines. The engineman must do his part of it.

I found also a man working his injector wide open; filled her full of water and went away, run her low and filled her up again. That would not work. As soon as I showed him there was a different way to pump an engine, taking advantage of the stops and getting a little water, and giving the fireman time in getting out of the station to apply his fire and regulate it before applying the injector again, there were good results brought about and the black smoke practically eliminated for the conditions we were laboring under.

Mr. Charles F. Richardson (Frisco Line): Mr. President, we will admit that a careful fireman, firing in cooperation with the engineer, will keep the black smoke down to a great extent.

Mr. Buell: During a period of about three years the company I work for sent me around from road to road just to demonstrate what saving could be made in fuel and the matter of smoke consumption, and in that time I think I went up against a good many of the problems that came up in that time. There were just two things that struck me more forcibly than anything else along this line, and in order to get the results I found that it resolved itself into almost two problems and no more. The first thing was to get the engine

drafted properly so that it would burn the fuel, and the second thing was to get the fireman to fire the engine properly. There is just one point I would like to bring out about instructing the firemen. You can talk until you are black in the face and it won't do a bit of good. The way is to get down and take the scoop yourself and show him that the results can be accomplished.

Mr. Wallace: Mr. President, I fully

tive that these results can be obtained on.

Mr. A. M. Bickel: I think that the railroads entering into Chicago are up against it as hard as any of the railroads in the way of black smoke nuisance. At least, I take notice that the road I am connected with gets hauled up occasionally in the city courts for violation of the smoke ordinance, and I believe that a ring blower at the bot-

### Busy Railway Station in London.

The accompanying illustration gives a good idea of the enormous amount of traffic, chiefly of a suburban character, that works in and out of Liverpool Street Station, London, during every period of twenty-four hours. The camera was, through the courtesy of the Great Eastern Railway officials, placed in the Bethnal Green signal box, which is situated in that mile or so of line just outside Liverpool Street Station, known as "the neck of the bottle." Here the eighteen platform tracks of the terminus converge into six, three up and three down, while farther out these meet four up and four down tracks, serving the network of suburban and main lines, all finding a terminus at Liverpool street. Through this bottle-neck, during the busiest periods of the day, 41 trains per hour work inward, and again outward; the average number of trains arriving or departing during each day of twenty-four hours is 990 in summer and 960 in winter. This apparently endless procession of trains conveys an average, inward and outward together, of over 176,000 passengers per day to and from the terminus, to say nothing of other passengers who may alight at or depart from intermediate stations in the metropolis. A large proportion of this vast total consists of business and work people, whose comings and goings are concentrated into two or three hours in the morning and the same in the evening, a fact which renders the uniformly smooth and punctual working of the Great Eastern traffic one of the wonders of the railway world.

Adding to the above figures about 62,000 passengers to and from Fenchurch street and 29,000 to and from Bishopsgate, the daily average of the Great Eastern Railway city stations is about 267,000 passengers. This enormous multitude, larger than a standing army, is daily handled quickly and safely.

### Aquatic.

A tramp has beaten all known records by swimming twenty-seven miles in thirty minutes. He did not mean to do it. He merely tried to steal a ride from St. Louis to Chicago on the rear of a locomotive tender. When the train started he fell over backward, through the open manhole, into the water tank. The noise of the train drowned his cries for help and he was obliged to swim until the first stop was reached, at Alton. When taken out he was nearly dead, but the engineer was so unfeeling as to call his attention to the fact that the water was only four feet deep and he might have stood up. The conductor, also unfeeling, asked for his ticket, but the tramp said he did not come by rail, but by water.—*Kansas City Star*.

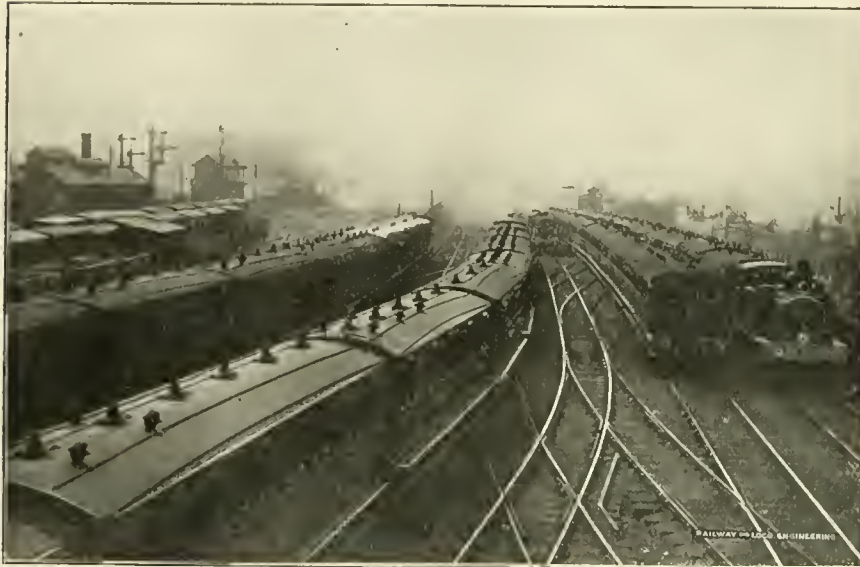

"NECK OF THE BOTTLE," FROM THE BETHNAL GREEN SIGNAL-BOX ON THE GREAT WESTERN RAILWAY OF ENGLAND.

agree with the remarks of the last speaker. We must show these gentlemen how to do the business.

In regard to the question that Mr. Richardson asked, the Traveling Engineer is up against a problem. Having filled that position and recommended suspensions for certain things before he had sufficient experience, perhaps, he found he did not get it. The master mechanic is not always able to suspend an engineer, who has possibly been in the service longer than he has and is drawing sometimes more money. If you do, it is the investigation before the suspension is given out or pay for the time lost. Another thing: Suspension will not give you service. Any man given authority can suspend a subordinate, but does it help? On the roads and divisions and railroads that I have been connected with the best service has always obtained where the least suspensions were, and I think we should not be timid in going about the performance of our duties, taking these matters up vigorously with the engineers, but do not suspend an engineer or a fireman until you know you are right. First be patient enough to educate the man, if possible, to perform the work as you direct. If he will not do it, that is time enough to give him the suspension; and before you do either you should give him a loco-

tom of the stack and two jets on either side in addition to a good brick arch will come the nearest to consuming black smoke of any device we have yet heard of. We are doing that now. We have some of our engines equipped with the brick arch and a ring blower in the stack, but nevertheless there are times when we get caught by the smoke inspectors, who are numerous, but it is on account of the engineer and fireman perhaps crowding their engine a little too much in order to do the trick, as it were, and then be given a signal to stop suddenly and all the smoke consuming devices in this country won't prevent some black smoke issuing from the stack. I believe that a good brick arch with a ring blower in the stack and two jets on either side immediately above the fire will come the nearest to preventing the violation of the smoke ordinance in the city of Chicago, where it is very strict, of anything that we have yet had.

(To be continued.)

"Originality," according to Josh Billings, is stealing with caution and kovering up with kare. When Josh wrote those words we believe that he had prophetic instincts of the inventors of motor vehicles who are now producing so much original mechanism. Josh's real name was Henry W. Shaw.

## Rogers 4-6-2, A. &amp; W. P.

A short time ago the Atlanta & West Point Railroad received some Pacific type or 4-6-2 engines from the American Locomotive Company. These machines were built at the Rogers works which are situated in Paterson, N. J. The engine is for passenger service, and is shown in our illustration.

The cylinders are 22×28 ins. and the drivers are 72 ins. in diameter. With a boiler pressure of 200 lbs. the tractive effort of this machine as calculated with the Master Mechanic's allowance for mean effective pressure of 85 per cent. of boiler pressure, is about 32,000 lbs. and the ratio of adhesion, with 130,000 lbs. on the driving wheels, is 4. The engine is, of course, a simple one with balanced slide valves driven by the ordinary shifting link motion with transmission bar which passes around the forward driving axle. The motion is indirect. The valve has a travel of 6 ins. in full gear and is set with 1-16 in. lead, and 1 in. lap.

All the wheels are flanged and the driving wheel base is 12 ft. 8 ins., the

enclosed between the rails of the track in front of the engine, would extend more than 750 feet ahead of the pilot. There are 278 tubes, each 20 ft. long, and these, if laid long the track with ends touching, would reach for more than a mile ahead. The roof sheet and the crown sheet are level and the back sheet is vertical. The throat sheet has a slope of 20 ins. and is 26¼ ins. deep. The fire box is of the wide type, that is, it extends out over the frames and has a grate area of 55 sq. ft. With the heating surface as given above this makes the ratio of grate to heat absorbing surface as 1 is to 64.2.

The tender is made with the regular U-shaped tank, which holds 7,000 gallons and carries 12 tons of soft coal. The tender frame is made of structural steel and the trucks are of the ordinary arch bar type with 36-in. spoke wheels. There is a Pullman vestibule on the back of the tender. The engine is equipped with Gold steam heat, Detroit seamless tubes, and Tate flexible staybolts. The engine is 70 ft. 1 in. long over all, 15 ft. 6 ins. to the top of

Fire Brick—Supported on Detroit steel tubes.  
Injectors—R. H. and L. H., size No. 10.  
Piston-rod diameter, 4 ins.  
Tender—Weight empty, 51,600 lbs.; wheel base, 16 ft. 9 ins.  
Driving Wheel Center—Material, cast steel; tires, held by retaining rings.

## Among the Railroad Men.

BY JAMES KENNEDY.

Niagara is singing the same old song—deep calling unto deep—that it has sung since the creation. The great central gorge on the Canadian side is deepening and the foaming rim of the wilderness of waters that fold over the awful cliff is changing in shape. The little island that separates the mighty torrent into two seething cataracts is slowly but surely falling to pieces. The glory of October is burning the surrounding foliage into scarlet and gold. The skies are of cobalt flecked with clouds of amethyst. The splendid railway bridges that span the river seem to have the abiding qualities of beauty and durability. Spreading cities are creeping nearer and nearer to the great cataract, for already half a hundred invisible wheels are being turned by the titanic force of the falling waters. Turbines, swifter and stronger than those of

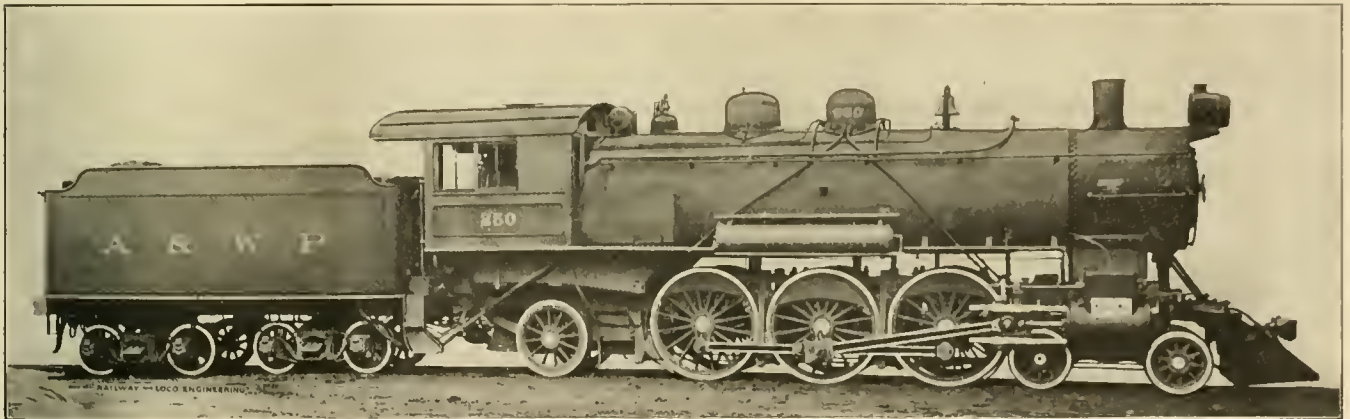

PACIFIC TYPE ENGINE FOR THE ATLANTA & WEST POINT.

F. O. Walsh, Master Mechanic.

American Loco. Co., Builders.

drivers being equally spaced 76 ins. apart. The adhesive weight as we have said is 130,000 lbs.; that carried on the engine truck is 46,000 lbs., while the trailing bears a weight of 36,000 lbs., making a total engine weight of 212,000 lbs. The total wheel base of the engine measures 32 ft. 5½ ins. and when the tender is added the whole becomes just 60 ft. The engine truck wheels are 36 ins. in diameter and the trailers are 50 ins. All the rods are of the fluted or I-section.

The boiler is a straight top one, with the front course measuring 72½ ins. outside diameter. The dome is on the third course well forward of the fire box. The boiler is liberally supplied with heating surface. There is 238 sq. ft. in the fire box, 3,261 in the tubes and 33 sq. ft. in the tubes supporting the brick arch. This makes a total of 3,532 sq. ft. This heating surface, if

the smokestack and 10 ft. 5 ins. wide, and is altogether a good example of a modern fast passenger engine. Some of the principal dimensions are here appended for reference.

Axles—Driving journals, main, 9½ ins. by 12 ins., others 9½ ins. by 12 ins.; engine truck journals, 6 ins. by 12 ins.; trailing journals, 8 ins. by 14 ins.; tender journals, 5½ ins. by 10 ins.

Boiler—Thickness ring, first ¾-in., second ¾-in., third ¾-in.; throat, 13/16-in.; dome, 9/16-in.; front tube, ¾-in.; roof, ¾-in.; side, 9/16-in.; back head, 9/16-in.

Fire Box—Depth, front, 76½ ins.; back, 68½ ins.; length at top, 127½ ins., and 107½ ins. at bottom; width, 73¼ ins.; thickness, crown 7/16-in., tube ¾-in., side ¾-in., back ¾-in.; water space, front, 4½ ins., side 4½ ins., back, 4½ ins.

Seams—Horizontal, sextuple riveted; circumferential, double riveted.

Stay Bolts—1 in. diameter.

Crown Stays—1½ ins. diameter.

Crank Pin—Size, main, 7¼ ins. by 7 ins.; main side, 7¾ ins. by 5 ins.; intermediate, front, 5¾ ins. by 4 ins.; back, 5¾ ins. by 4½ ins.

Cylinder—Steam ports, 1½ ins. by 21 ins.; exhaust ports, 3 ins. by 21 ins.; bridge, 1¼ ins.

Engine Truck—Type, 4 wheel swinging.

Trailing Truck—Type, Rogers, inside bearings.

Exhaust Pipe—Malleable iron.

the *Lusitania* are sending the harnessed currents of electricity in every direction. Electrically driven cars are impelled by the invisible current, and by steam railway in the lap of luxury as it were, we are away on our journey to Buffalo. On our way we halt for a few hours.

AT DEPEW, N. Y.

A few years ago this was a flat tract of unproductive land. Now it is an expanding city. The great central industry is the extensive shops of the New York Central Railroad, built on colossal proportions and adding wing to wing. The chief buildings cover ten or twelve acres and extensive additions are in contemplation. The repair shops have a roominess about them that has to be seen to be appreciated. The engines are not huddled together like hawker's barrows, but stand apart the way that all great things should do. There are no galleries in the great

shop and the light is clear as day. The only obstruction overhead is the great traveling cranes that lift the 150-ton engines like toys and carry them from place to place. The fine machines which fill several of the far extending wings are grouped in sections and many are electrically driven, the installation of the motors going on as rapidly as possible. The offices of the superintendent of motive power, Mr. C. H. Hogan, are the most capacious we have ever seen. He could move an engine around in his commodious office.

It was very pleasant to observe the friendly terms on which Mr. Hogan and his assistants associate with the workmen. There is no pride there, and the number of elderly men bear kindly testimony to the fact that there is no weeding out process going on among the men who have grown gray in the service. In fact, Mr. Hogan brought a number of men from East Buffalo who had served under him there. He did not desire to leave a heritage of veterans to his successors, so he took them with him, and their skill in handling the fine machines with which the shop is equipped bears ample testimony to their ability.

Another admirable feature about the works is the establishment of a drawing school under the able tutorship of Mr. George Kuch, who has fitted up a regular school with all the necessary apparatus used in mechanical drawing with models of almost every part of the modern locomotive. The classes meet twice a week in the forenoon. There are three classes in all, with twenty-six pupils in each class, so that Mr. Kuch is engaged every day in instructing the apprentices. It needs hardly be noted that the company furnishes everything except the smaller drawing tools, with which each apprentice is expected to equip himself. Under this method a regular apprenticeship of four years will include about six months' instruction in mechanical drawing, with special lessons in geometry and mensuration of surfaces and solids, embracing a complete course in applied mechanics.

#### AT BUFFALO, N. Y.

The Pennsylvania Railroad shops at Buffalo are not so extensive as the new works at Olean or the old establishment at Altoona, but what they lack in size they make up in perfection of detail. Mr. A. Vail, master mechanic, is one of the most accomplished railway men in the service of the company, and he is ably assisted by Mr. W. L. Davis. Mr. Vail was particularly interesting in his reminiscences of early railroading in Northern New York. He was in charge of the repair shops when the Pennsylvania Company took control of the Olean, Bradford & Warren Railroad in 1879. It was a narrow gauge road and they had a dozen of small locomotives built by Mason of Taunton, Mass., and furnished with the first examples of

the Walschaerts valve gear used in America. Mr. Vail was delighted with the new valve gear, and used every effort he could towards its general adoption on the larger locomotives. He had not the commanding position then that he has now and his voice was like the voice of one crying in the wilderness. Then the mantle of prophecy fell upon him and he predicted that the day would come when others would see the superiority of Walschaerts' masterly invention. His prophecy was long in being fulfilled, but it is coming true just the same, and the ingenious contrivance can be seen swinging past Mr. Vail's office window every hour in the day.

Mr. C. C. Leesh, the shop foreman, ably supplements the work of his accomplished superior officers. As a machine shop yard master his work is worthy of example. There is a place for everything and everything is in its place. His classification and storing of wheels and casting and general stores is the most methodical and orderly that we have seen, while his masterly quality of grouping machinery is worthy of more extended notice. His flue welding apparatus furnishes a fine example of compact orderly work where one man can easily cut and weld over 300 flues a day. Mr. Leesh has also perfected a fire brigade in the shop and by a system of signals water can be turned on in any part of the shop in less than a minute. He is a great believer in compressed air and his adaptation of this power is seen all over the works. We had the pleasure of seeing an air hammer knocking out a refractory rod bolt with a few blows, the blows being regulated in number and intensity by a simple contrivance; indeed the number of labor saving devices was remarkable.

It may be added that the piece work system, which is in general vogue in these works, seems under Mr. Leesh's supervision to work very harmoniously. The workmen are intelligently and actively interested in their work, but there was not the slightest appearance of hurry anywhere, but the contrary. In fact, machinery seemed to be doing everything, while the skilled mechanic merely looked and touched a handle here and a lever there and the thing was done.

#### AT YOUNGSTOWN, OHIO.

The Iron City is a fine example of a prosperous, expanding industrial town. There is quite a metropolitan air about the active, shrewd-faced men and elegantly dressed women. It is a great railroad centre, but the principal construction and repair works are elsewhere. The extensive yards of the Pennsylvania Railroad are ably managed by Mr. Joseph Perry, the veteran yard master. He is not one of these functionaries who sit ensconced in a cozy room busy with a bundle of meaningless documents, while a poorly paid

yard clerk is doing the work of getting the trains together. Mr. Perry is on the job. He has the energy of a trained athlete and the masterly methods of an adjutant. It is doubtful if a larger amount of freight traffic is handled anywhere as expeditiously as it is in this great yard. The men are busy without any bustle. A select body of experienced engineers are in this yard. Among others, it was a real pleasure to meet Mr. P. J. Mahar, a fine example of the self-taught engineer. He was loud in his praises of RAILWAY AND LOCOMOTIVE ENGINEERING, from which, he declared, he had learned nearly all he knew. A well thumbed copy of the "Railroad Men's Catechism" showed how carefully he had conned the latest authority on the mechanical appliances used on railways. It was gratifying to learn that in ten years' service Mr. Mahar already owns a fine house in Forest Avenue, with grounds that might bring tears to the eyes of a dweller in a Harlem flat, in which cramped abode a moderately sized dog cannot wag its tail horizontally, but must express its joy, on seeing its master, vertically. It may be added that Mr. Mahar's fine residence is all paid for, while his rapidly increasing library shows how wisely he spends his few hours of relaxation.

#### Plenty to Do.

The American Locomotive Company do not seem to be in any dread of the steam locomotive becoming unpopular in the near future, if one may judge from the orders recently booked. Among many others they are building 2 Mogul locomotives for the Savannah, Augusta & Northern; 4 metre gauge consolidation locomotives for Bolivia; 1 ten-wheel locomotive for Santa Fe, Raton & Des Moines; 1 six-wheel switching locomotive for Memphis Warehouse Co.; 8 six-wheel switching locomotives for Galveston Wharf Co.; 1 eight-wheel locomotive for Yosemite Valley Railroad; 1 six-wheel switching locomotive for Carnegie Steel Co.; 1 four-wheel switching locomotive for the Burden Iron Co.; 1 Mogul locomotive for Green Bay & Western Railroad; 1 four-wheeled tank engine for Hanyang Steel & Iron Works; 2 consolidation locomotives for Sierra Madre Land & Lumber Co.; 2 electric locomotives for Williamette Construction Co.; 2 electric locomotives for the Chicago & Milwaukee Electric Railway; 2 six-wheel switching locomotives for the Manufacturers' Railway; 3 consolidation locomotives for the Virginia & Southwestern Railway; 1 Mogul locomotive for the Norwood & St. Lawrence; 1 Prairie type saddle-tank locomotive for the Cia. Carbonif de Sabinas, Mexico.

# Items of Personal Interest

Mr. R. L. Doolittle, formerly on the Central of Georgia Railroad, has been appointed master mechanic on the Atlanta, Birmingham & Atlantic at Fitzgerald, Ga.

Mr. D. W. Cunningham has been appointed assistant superintendent of motive power on the Missouri Pacific, with headquarters at Little Rock, Ark.

Mr. E. J. Grimes has been appointed purchasing agent of the Missouri Southern, with office at Leeper, Mo.

Mr. Charles Branch, formerly general foreman of shops at Moberly, Mo., succeeds Mr. Green at Landers, Ill.

Mr. G. David has been appointed traveling fireman, district No. 2, Eastern Division of the Canadian Pacific Railway.

Mr. T. Richmond has been appointed traveling fireman, district No. 2, Eastern Division of the Canadian Pacific Railway.

Mr. G. J. Duffy, master mechanic Canadian Division of the Michigan Central Railroad, St. Thomas, Ont., has resigned.

Mr. S. H. Spangler has been appointed master mechanic of the St. Louis, Watkins & Gulf, with office at Lake Charles, La.

Mr. James F. Green, formerly general foreman of shops at Landers, Ill., has been transferred to Springfield, succeeding Mr. Smith.

Mr. J. J. Hanline has been appointed master mechanic of the Seaboard Air Line at Atlanta, Ga., vice Mr. A. J. Poole, promoted.

Mr. Arthur W. Baker has been appointed fuel agent of the Atchison, Topeka & Santa Fe Railroad, with office at Cleburne, Texas.

Mr. W. F. Canavan has been appointed general foreman of locomotive shops of the Missouri, Kansas & Texas Railroad at Parsons, Kan.

Mr. John W. Swales has been appointed round house foreman for the El Paso & Southwestern Railway, with headquarters at Douglas, Ariz.

Mr. E. M. Peden has been appointed superintendent of motive power and rolling stock on the Santa Fe Central, with office at Estancia, N. Mex.

Mr. J. H. Nash has been appointed master mechanic of the Illinois Central, with headquarters at Paducah, Ky., vice Mr. R. E. Fulmer, resigned.

Mr. E. E. Chrysler, formerly general foreman, has been appointed master mechanic of the Chicago, Rock Island & Pacific at Chickasha, Ind. Ter.

Mr. G. J. Mills has been appointed road foreman of engines of the First Division of the Atlantic Coast Line, with headquarters at Rocky Mount, N. C.

Mr. J. F. Farrell has been appointed purchasing agent of the Michigan Central Railroad, with headquarters at Chicago, vice Mr. S. B. Wright, resigned.

Mr. C. A. V. Axen, formerly foreman of shops at Green Bay, on the Chicago & North-Western, has been transferred to Antigo, vice Mr. Charlton, promoted.

Mr. E. F. Fay, formerly general foreman on the Union Pacific at Omaha, Neb., has been appointed master mechanic on the same road, with office at Denver, Colo.

Mr. L. K. Smith, formerly general foreman of the shops of the Wabash at Springfield, Ill., has been appointed assistant division master mechanic at Moberly, Mo.

Mr. E. I. Dodd, formerly mechanical engineer of the Pullman Company, has been appointed assistant mechanical superintendent of the Erie, with office at Meadville, Pa.

Mr. H. Paton, locomotive engineer, Stratford, Ont., has been appointed instructor and examiner of engineers for the Middle Division of the Grand Trunk Railway.

Mr. F. W. Dickerson, formerly general foreman of the car department, has been appointed master car builder of the Bessemer & Lake Erie, with office at Greenville, Pa.

Mr. C. H. Johnson has been appointed general foreman, Locomotive Department of the Chicago District on the Michigan Central Railroad, with headquarters at Chicago, Ill.

Mr. Alfred Lovell has tendered his resignation as superintendent of motive power of the Atchison, Topeka & Santa Fe, for the purpose of engaging in private business.

Mr. H. J. Osborne has been appointed master mechanic of Nebraska & California Division of the Chicago, Rock Island & Pacific Railway, with headquarters at Goodland, Kan.

Mr. S. B. Wright, purchasing agent of the Michigan Central, has been appointed purchasing agent of the New York Central & Hudson River Railroad, vice Mr. Dexter Fairchild, resigned.

Mr. John Charlton, formerly foreman of shops of the Chicago & North-Western at Antigo, Wis., has been appointed acting division master mechanic at Chicago, vice Mr. L. M. Carlton, resigned.

Mr. J. H. Nash, division master mechanic of the Illinois Central Railroad at East St. Louis, Ill., has been transferred to Paducah, Ky., as division master mechanic, vice Mr. R. E. Fuller, resigned.

Mr. A. J. Poole, formerly master me-

chanic at Atlanta, Ga., on the S. A. L., has been appointed to the new position of general master mechanic of the Seaboard Air Line, with office at Portsmouth, Va.

Mr. William Murdoch, the Scottish mechanical engineer who invented and first introduced gas illumination, belonged to the same family as the Hon. James Wilson, our very able Secretary of Agriculture.

Mr. A. Buchanan, Jr., has resigned his position of superintendent of motive power of the Central Vermont Railway, to take service with the Public Service Commission in the second district, New York State.

Mr. R. C. Evans has been appointed superintendent of motive power and car departments of the Western Maryland Railroad, with headquarters at Union Bridge, Md., vice Mr. Wm. Miller, resigned.

Mr. R. D. Smith, formerly mechanical expert of the Lake Shore & Michigan Southern, has been appointed assistant superintendent of motive power of the Boston & Albany, with headquarters at Albany, N. Y.

Mr. T. Rumney, mechanical superintendent of the Erie Railroad of Meadville, Pa., has been appointed general mechanical superintendent of all the company's lines. His headquarters will hereafter be in New York.

Mr. R. Tawse, formerly master mechanic of the Ann Arbor Railroad, has been appointed superintendent of motive power of that road and of the Detroit, Toledo & Iron Mountain Railroad, with headquarters at Jackson, Ohio, vice Mr. W. G. Wallace, resigned.

Mr. Robert McKibben, master carpenter of the Monongahela division of the motive power and car departments of the Pennsylvania, has been promoted to be master carpenter for the middle division with headquarters at Altoona, Pa., vice Mr. A. H. Kline, promoted.

Mr. Leslie G. Roblin has been appointed road foreman of engines on the Canadian Pacific Railway, between Toronto and Windsor, with headquarters at London, Ont. He is a painstaking and intelligent railroad man and is likely to be very successful in his new field of work.

Mr. H. Montgomery, who was lately appointed assistant superintendent of motive power and equipment of the Bangor & Aroostook Railroad, has been promoted to be superintendent of motive power and equipment of that road, with office at Milo Junction, Maine, vice Mr. O. Stewart, resigned.

Mr. G. H. Hutchinson was formerly road foreman of engines on the Central Railroad of New Jersey. He has gone to Salt Lake City in the service of N. B. Livermore & Co., who represent the American Locomotive Company and the Atlantic Equipment Company in the West.

Mr. E. J. Harris, formerly general foreman of the C., R. I. & P. shops at Valley Junction, has been appointed master mechanic of the Iowa and Des Moines Valley divisions of the Chicago, Rock Island & Pacific, with headquarters at Valley Junction, Ia., vice Mr. W. D. Cunningham, resigned.

Mr. William Schlafge, who has been heretofore assistant mechanical superintendent of the Erie Railroad, has been appointed mechanical superintendent of the Grand Division of the Erie and of the New York, Susquehanna & Western Railroad, vice Mr. T. Rumney, promoted. Mr. Schlafge's headquarters will hereafter be at Jersey City, N. J.

Mr. Robert Johnston, for many years foreman boiler maker at the shops of the New York Elevated Railroad, has been appointed special car inspector by the Interborough Company of New York. Mr. Johnston is at present at Berwick, Pa., inspecting the construction of a large number of new cars which are being built there for the Subway, New York.

Mr. Edward G. Moan has accepted a position as general foreman at Waycross, Ga., on the Atlantic Coast Line Railway. Extensive new machine shops have been built there and he is installing the new machinery. He was occupied for some time as special instructor on the Erie Railroad. Mr. Moan is a graduate of the Cooper Institute; a fine draughtsman and an experienced machinist.

Mr. R. H. Oakley, of Elizabeth, N. J., has entered the car department of the Erie Railroad at Kent, Ohio. Mr. Oakley has had an extended railroad experience, having served in the car department of the Canadian Pacific, at Winnipeg, Man., and on the Great Northern at St. Paul, Minn., and as general foreman of the car department of the Central Railroad of New Jersey at Elizabethport, N. J.

Mr. Charles Graham has accepted a special appointment in the employ of the American Locomotive Company, with headquarters at Scranton, Pa. Mr. Graham was engaged as master mechanic for some years on the Delaware, Lackawanna & Western Railroad at Kingston, Pa. For the last two years he was in the employ of the Baldwin Locomotive Works. Mr. Graham is a graduate of the Lehigh University and is a mechanical engineer of thorough training and ability.

Mr. W. G. Wallace, whose very ingenious smoke stack was mentioned in our October paper, page 477, has lately resigned his position of superintendent of

motive power of the Detroit, Toledo & Ironton Railway and of the Ann Arbor Railroad. His plans for the future are not quite settled at present, and any company or concern who may be looking for a man with Mr. Wallace's well-known abilities and experience should communicate with him as soon as possible. His address is 5217 Calumet avenue, Chicago, Ill.

Mr. Frank Lane, who for the past fifteen years has been identified with the editorial department of *The Railway Age*, has resigned his position with that paper for the purpose of devoting himself to independent literary work of a general and technical character. His long and varied experience and his ability as a clear thinker and writer will assure Mr. Lane of success wherever he goes. He is a graduate of Dartmouth College, and was at one time a special examiner of patents in the Department at Washington. He is a member of the American Society of Mechanical Engineers, the American Railway Master Mechanics' and the Master Car Builders' Associations. His address is 87 St. Nicholas Place, New York City. The staff of RAILWAY AND LOCOMOTIVE ENGINEERING joins Mr. Lane's many friends with best wishes for the fullest measure of success in his new field of work.

#### First Railway Porter.

England's first railway porter has just died at Darlington, in the person of Mr. John Cooper, one of the oldest veterans of railway service. Mr. Cooper, who was born in the year of the Battle of Waterloo, commenced as a porter on the first public railway—the Stockton and Darlington line. As a guard in the early railway days, his duty was to ride on a "dickie" on the roof of the rear carriage, so that he might be enabled to look along the whole length of the train. He eventually became personal attendant to George Stephenson, manager of the first public railway, a post he held for many years. Mr. Cooper retired from railway service only four years ago on a weekly pension of six shillings, but, having no other means or relatives, became an inmate of the Darlington workhouse.—*Montreal Witness*.

#### Ho for Atlantic City.

At a joint meeting of the executive committees of the American Railway Master Mechanics and Master Car Builders' associations it was decided to hold the next M. M. and M. C. B. conventions at Atlantic City, N. J. The Marlboro-Blenheim Hotel will be headquarters for the executive committees of both associations, but the meetings and the exhibits will be on Young's million dollar pier. The dates for the Master Car Builders' meeting is Wednesday, June 17, 1908, and the Master Mechanics' begins on Monday,

June 22. Each session lasts three days, and Saturday, June 20, as a holiday between the conventions.

#### Fast Work and Good.

In an article on Thomas Edison which recently appeared in the New York Tribune, a little anecdote of his ability as telegraph operator is thus set forth: "This story is told of him in those early days when he worked at the telegraph key: The Western Union Telegraph Company needed a good operator to take charge of the Boston end of the heaviest wire from New York. Successive applicants for the place had been tried and had failed. A friend of Edison's recommended him for the post. He was at that time working in Port Huron. A telegram brought him to Boston, and when he showed up in the office his appearance caused a general laugh among the operators.

"His attire was slovenly, and he wore trousers that reached little more than half way from the knee to the shoe top. His natural awkwardness of movement was accentuated by the clothes he wore and his generally unkempt appearance. At the New York end of the wire he was to handle, there was one of the fastest sending operators in the service of the company. It seemed ridiculous that this awkward country boy should be put up against him. Without a word young Edison took his seat at the key, and for four hours received messages as fast as the man at the other end of the wire could send, transcribing the dots and dashes in writing almost copper plate in its legibility. Not once in the four hours did he have to interrupt the sender to have parts of messages repeated. When the trick was done the New York operator thus expressed his amazement:

"'Who the devil are you?' he ticked over the wire.

"'I'm the new man. "Tom" Edison is my name,' came the answer, ticked off even faster than the question.

"'Well, you are a good one. Been looking for you for ten years. You are the only man that could ever take me without a break.'

#### Time Book Given Away.

In pushing his business that energetic hustler H. S. Peters has arranged a time book for train men which he is giving away free to any one who sends for it. The book contains valuable information for railroad men, besides the blank pages for entering time. It makes a nice diary, and has the merit of preventing mistakes in time and mileage keeping. Apply to H. S. Peters, Dover, N. J., and tell him that we commended the time book.

### The Boys at Jackson, Mich.

The instruction of apprentices at the Jackson, Mich., shops of the Michigan Central Railroad are under the immediate supervision of Mr. C. P. Wilkinson, the drawing teacher at that point. Our illustration presents the class in working dress taken outside the shops. It is a typical group of intelligent and healthy young manhood, good material all through. We give below some remarks made by Mr. Wilkinson in sending the photograph to us. Mr. Cross is the official head of the whole instruction department of the New York Central Lines

when they show ability in that line, is being carried out here and is a grand thing, and so far, we have had no difficulty in having enough in reserve to follow this practice and we expect to continue. Some of the benefits derived from this practice makes it possible for a great many schemes to be worked out in connection with shop ideas that otherwise could not be, and at the same time gives the boys valuable experience, and again boys who can make drawings and understand them are given an opportunity of laying out work instead of having it the old way where one person had all the practical

posure, and that a moving picture be made up by the rapid presentation of these photographs in the proper sequence. The plant might have taken three months to grow, but its whole development would thus be presented in the space of perhaps five minutes.

One of the best uses of the cinematograph, which we have seen, was placed before the New York Railroad Club at its last meeting. Monsieur E. Ronceray, of Paris, France, read a most interesting and highly instructive paper on machine moulding for railroad work, and at the close of his remarks, after some diagrams



GROUP OF MICHIGAN CENTRAL APPRENTICES AT THE JACKSON, MICH., SHOPS.

of which the M. C. R. R. is a part. Mr. Wilkinson says:

"From the standpoint of one who comes daily in contact with this work I cannot speak too highly of the present apprentice system on the New York Central Lines under which we are working. That great benefit to both the railroad company and the boys will be derived from this system there is no question and in many cases results for good begin to show almost from the moment a boy enters the shops as an apprentice. Of course this does not apply to all, and never will. The system required to meet needs, or what is to the liking of the average boy wishing to learn a trade, must certainly be broad, and one that can be made to suit each individual case, as this is what we find. It would not be just to judge a boy by his school work as to his value in the shop as in so many cases we find those not up to standard in one place make the very best in the other. We can say, however, that the boys who make a showing in class work as a rule make good in shop work.

The practice of giving the boys two months' experience in the drawing room,

work to do. There will be a large number in time that we can call on for this kind of work, and what applies in one case will apply in all others.

The one great point not to be lost sight of in this work is not to expect too much from the boys and to have a great deal of patience; this applies to all those who have anything to do with boys. In connection with the school work, the shop instructor devotes part of the class-hours to the advanced boys, taking up valve setting, quartering of wheels, laying out axles, etc., but in the room adjoining the school room so not to interfere with other work."

#### Machine Moulding.

Some years ago, when moving picture machines were new, their use for educational purposes was spoken of. A suggestion was made that a class in botany could be shown a moving picture which would practically make a plant grow, before the eyes of the class. The idea was to take some plant and photograph it once or twice every day, the camera being kept in exactly the same place for each ex-

had been exhibited on the screen, the moving picture machine reproduced several scenes in a French railroad shop where M. Ronceray, in the smock and overalls of a practical workman, made a number of green-sand moulds for railway castings with a rapidity and dexterity which delighted his audience.

In France it was the railroad demand for machine molding which mainly developed the remarkable and novel system of pattern making and machine molding in that country.

Patterns are made by the use of a non-shrinking white metal mounted on stripping plates and put in molding machines. The machines used have many time and cost saving features.

"Wooden patterns," he said, "will unquestionably mold work on machines, and, when the work is large and rough, as long as they hold together and do not become so ragged as to tear the sand, the molds they leave pass for molds, although they, as a rule, require much more mending than molds made from metallic patterns and stripping plates."

The "Pridmore" is the name of the

French machine, and it is a very remarkable and efficient foundry tool, being operated by hydraulic pressure, and it is so made that it can be turned upside down as required by the molder. It is mounted at its centre of gravity and all but the larger size of machine can be inverted by hand. On this machine two men mold 600 shoes for a day's work, and they help to pour them. The machine used in France for brake-shoe molding, in connection with the assembling machine for making molds *en motte*. In this case, as is usual over there, the head and shoe are combined in one casting.

#### Useful Souvenir.

A good many people think that the souvenir season is in June when the railway conventions are in full swing, but the souvenir season really exists all the time. One of the most useful desk accessories which we have seen comes from the Coes' Wrench Company, of Worcester, Mass., as a souvenir. It is a paper cutter or letter opener made of celluloid and is in outline like one of the Coes' wrenches. The handle of the wrench has been ingeniously made the blade of the paper cutter and the irregular outline of the adjusting screw and the jaws of the wrench gives one a good grip on the cutter, and when wielded by a good man and true, no sealed envelope can withstand its insinuating thrust. The company are distributing the wrench paper cutter among their friends, and a post card addressed to them at Worcester, Mass., might result in a paper cutter coming your way.

#### Removable Driving Brass.

Something that will be of interest to the motive power officers is a patent just issued to Mr. Charles Markel, of Clinton, Iowa, covering what is termed a "Removable Driving Box Brass." Mr. Markel has been for a number of years foreman of the machine shops of the Chicago & North-Western Railway at Clinton, Ia. Having to deal with a good many loose brasses in driving boxes, he conceived the idea, shown in our illustration, of holding the brass in the box with a wedge instead of pressing it in, as is the present practice. The illustration is an elevation of a driving box, showing the brass and wedge. Under one extremity of the brass is cut a slot in the box of suitable size and shape to receive a wedge, which is driven in  $1\frac{3}{4}$  ins., which so tightens the brass as to require 40 tons pressure under hydraulic press to start it. The wedge extends through under the entire width of brass. There is a tapped hole in end of brass to receive a bolt for removing the brass by hand, and also a tapped hole in the end of the wedge to receive the device for pulling out the

wedge. There is also a set screw which passes in through one flange of the axle box. The point of this screw bears upon the end of the wedge, and holds it firmly in place and prevents any possibility of it slacking back.

By Mr. Markel's method the brass is turned  $\frac{1}{32}$ nd smaller than box fit, and when the wedge is driven the brass is forced to make a tight, solid joint on the outside, every part of the brass being in solid contact with the box. The brass is put in the box, and is then forced up to place by the wedge.

If through heating, or any other cause, the brass becomes loose, all that is necessary is to drive the wedge a little more, and so tighten the brass. In case it is desirable to remove the brass to shim it, or put in a new brass, all that is necessary is to lift the weight of the one box from the axle, pull the wedge and the brass, slip in a new brass, drive the wedge back to place, and the engine is ready for service; no drop pit, no dismantling of the engine, and there is no delay to the engine.

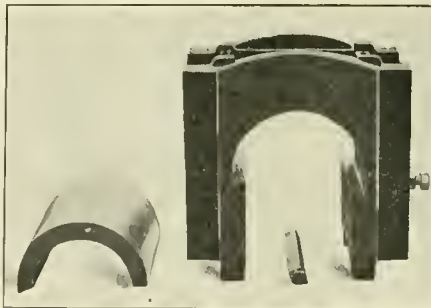

REMOVABLE DRIVING BRASS.

In the general use of this device, the openings in the boxes can all be made to a certain standard for certain classes of engines, and brasses and wedges kept in stock machined to fit the boxes, so that the only machine work immediately necessary for putting in a new brass would be the fitting of the brass to the journal.

The key is made from cold rolled machine steel, and planed on top and bottom sides only. The key is first placed in jig and  $\frac{1}{8}$  in. cut taken from the metal. It is then placed with planed face down in jig and planer tool brought down to hardened face on jig, and when cut is taken across the key, it is finished as to taper and angle.

The keys are drilled and tapped in jigs, also the same jig is used to drill the recess in side of key for end of set screw. The keys are tapped out at the large end  $\frac{7}{8}$  in., 12 thread, and hexagon head bolt screwed in loosely. This bolt is used to drive on, which prevents upsetting the end of key. This bolt and also the set screw has  $\frac{1}{8}$ -in. hole drilled in end, which hole is used

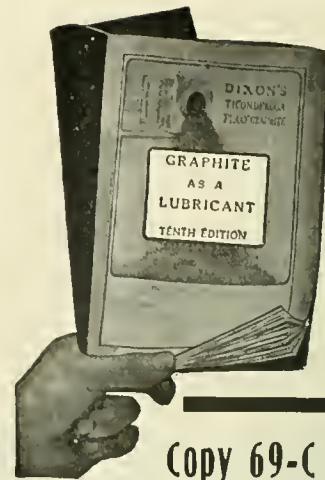

Copy 69-C FREE

Here is a complete and interesting story of graphite and its development as a lubricant. You can not get in any other book of equal size so much information of REAL value. The experience of practical men and the experiments of scientific authorities are both given in this TENTH EDITION of

## "Graphite as a Lubricant"

making it valuable to men of practice and students of theory.

Lubrication in almost every kind of machinery is treated of. "Kinks" and "short-cut" methods discovered and used by resourceful engineers are included.

You should get this book now. Write for FREE copy 69-C.

JOSEPH DIXON  
CRUCIBLE CO.  
Jersey City, N. J.



# GOLD Car Heating and Lighting Co.

Manufacturers of

**ELECTRIC,  
STEAM AND  
HOT WATER  
APPARATUS  
FOR RAILWAY CARS**

**EDISON  
STORAGE  
BATTERY  
FOR RAILWAY CAR  
LIGHTING**

**Largest Manufacturers in the World  
of Car Heating Apparatus**

**Catalogues and Circulars  
cheerfully furnished**

**Main Office, Whitehall Building  
17 BATTERY PLACE  
NEW YORK**

to back out the bolt or set screw in case they should become broken.

These boxes have been thoroughly tested in service on the C. & N. W. Railway, the first one being placed on an Atlantic type passenger engine, in fast passenger service on a 200 mile division, April 9th, 1906. It is in service now, never having given any trouble. July 4th, 1906, Engine 464, same type, same service, same division, was turned out of the shop with all of her boxes using this brass, and after one year and two months boxes are in good order, and have given no trouble. Engine 1314, same type, same service, 210 mile division, equipped with these boxes January 1st, 1907, has given perfect satisfaction. The Duluth, Missabe & Northern fitted up one box under an engine in extremely heavy service, simply from blue prints furnished, May 14th, 1906, and it has given every satisfaction after 16 months' service. There are now 36 of these boxes in service. The Locomotive Improvement Company, Clinton, Ia., handle this device for Mr. Markel, and will be happy to give any further information on the subject.

#### All-Steel Box Cars for the U. P.

The Union Pacific Railroad have ordered 25 all-steel cars. With a capacity of 50 cubic feet more than that of the standard Union Pacific wooden box car, the steel car weighs two tons less or 37,800 lbs. A 15-in. steel I-beam forms the center sill of the car below the double steel flooring. It is said that tests have shown that the ½-in. sheet steel forming the sides and ends of the car is stronger than the wood usually used. Tests have also developed the fact that the steel underframe of a wooden box car cannot stand up against the all-steel box car. In collision the end of a wooden car is usually badly damaged, while the steel car is comparatively uninjured. The doors of the steel car are formed by single sheets of steel reinforced.

#### American Locomotive Co.'s Report.

In the last fiscal year the American Locomotive Company did the largest amount of business since its organization six years ago. It built new shop buildings and power plants and installed machinery and equipment at its different works, particularly at Schenectady, Dunkirk, Richmond and Montreal; these improvements cost \$1,692,859, and were paid for out of the extraordinary additions and betterment fund of \$2,000,000 created last year. An equal amount has been set aside to carry on similar work next year. During the past year \$5,000,000 5 per cent. notes, maturing in five equal annual installments from October 1,

1907 to October 1, 1911, were issued to provide working capital. Last spring the structural steel department at Montreal was sold to the Structural Steel Company, Ltd., and the Locomotive & Machine Company of Montreal will hereafter build only locomotives, steam shovels and rotary snow plows. The report shows activity in all departments and shops of this enormous concern, with good prospects ahead.

#### Tamping Ties by Air.

Frank Gilroy, chief engineer of the New York Central's compressed air system in Buffalo, has invented a device for tamping up ties with pneumatic tools which assure a uniform stroke. Experts are of the opinion that such a method will solve the problem of broken rails. Mr. Gilroy's invention is to be tested on the West Shore at Utica.

The device for furnishing the air is carried on a skeleton rubble car and is said to be light enough for any ordinary gang to lift from the track. Rubber hose carries the compressed air to the tools, which are operated simultaneously on opposite sides of each tie and pound away at the rate of several hundred strokes each minute.—*N. Y. Commercial.*

#### Mexican International Shops.

The Mexican International Railway Company are taking advantage of the use of electricity in shop work and have just completed the installation of a large equipment of this apparatus. The apparatus for the Durango shops will consist of two engines of the non-condensing type, 18x36 ins., operating at 100 lbs. steam pressure and running at 120 r.p.m. These engines will be directly connected to two Westinghouse direct current generators, having a capacity of 200 K.W. each and wound for 250 and 125 volts, thus permitting lights and power to be supplied from the same generator with high economy and great flexibility. The generators are of the three wire type, giving the two voltages already mentioned.

The shops of Monclova will be equipped with a similar type of apparatus, with the exception that the engines will be of smaller capacity, the generators being two in number and of 100 K.W. capacity each, running at 120 r.p.m. There will also be supplied in connection with this plant the usual number of motors, arc and incandescent lights. All of the electrical equipment will be Westinghouse manufacture, this latter company being represented in the Republic by Messrs. G. & O. Braniff & Company, which firm secured the order. Both the electric and steam plant are of the most recent developments in the electrical and steam engineering line.

### Train Lighting by Electricity.

Many passenger trains to-day are lighted by glowing electric lamps and cooled by electric fans, some are also wired for electric heating devices. One of the earlier methods of producing electricity was by the installation of a small reciprocating engine, connected with the locomotive boiler, and driving a generator. The small engine and generator were in the baggage car. The new Curtis steam turbo-generating set, produced by the General Electric

cial form of metallic packing and screw glands are provided for taking up wear on the packing. The bearings are ball seated and babbitt lined. The main bearing is provided with thrust washers at each end to maintain the alignment of the buckets and to take up thrust due to shocks in coupling cars.

The governor is of centrifugal type and operates a valve through an oil lubricated ball-and-socket joint and a single lever of simple construction. This valve controls the whole supply

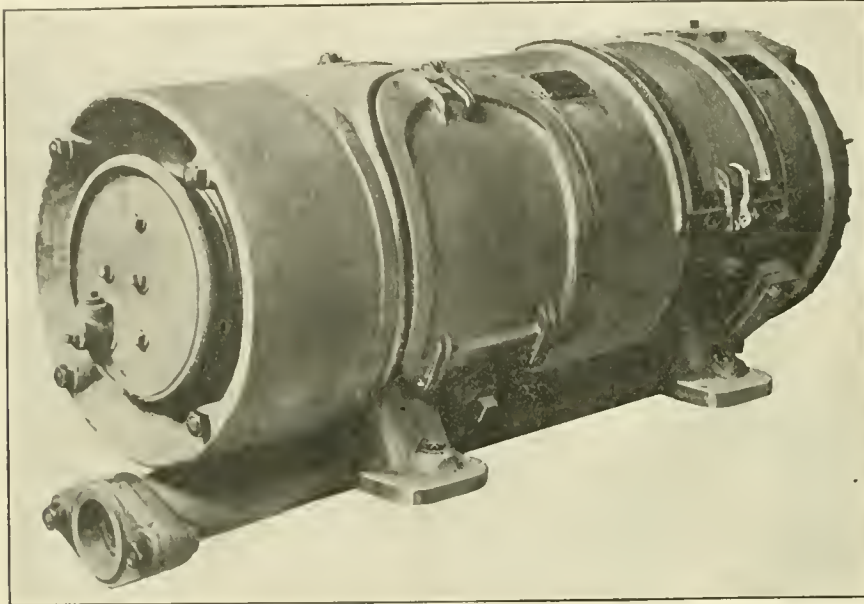

TURBINE GENERATOR FOR USE ON TOP OF LOCOMOTIVE BOILER.

Company, is now in successful operation on a number of roads, and where the engine is not detached this set can be used without a storage battery. The train lighting turbines used are of two types, the one for operating directly is placed on top of the locomotive boiler, and the other kind takes up only a small space in the baggage car.

When the turbine is mounted on the locomotive, flexible steam connections are eliminated. If the design of the locomotive is such that there is not room for this form of generator, the absence of vibration in the turbine makes it convenient to place it in the baggage car.

Three sizes of turbines are available for locomotive service, namely 15, 20 and 25-Kw. sets. These sets have each only two bearings. The bucket wheel is machined from a solid blank of forged steel and has three rows of buckets cut in its periphery. It has a taper fit and is forced on the shaft just outside of the main bearing. The governor screwed on the shaft beyond the wheel acts as a nut to hold the wheel in place.

The shaft where it passes through the wheel casing is packed with a spe-

cial form of metallic packing and screw glands are provided for taking up wear on the packing. The bearings are ball seated and babbitt lined. The main bearing is provided with thrust washers at each end to maintain the alignment of the buckets and to take up thrust due to shocks in coupling cars. This is tripped by a centrifugal device called the emergency spring, two of which are mounted on the governor frame. As this set is exposed to the weather, it is entirely enclosed, and has a fan for ventilation. Special precautions have been taken to exclude rain and snow. Large covers are provided over the governor, main bearing and brushes. These are similar to those used on railway motors, being packed with felt and fastened with special clamps requiring no tools to loosen.

For the baggage car, the sets are of the same general construction as the locomotive-type machines, except that no rain shields or special ventilating features are provided. The 25 and 35-Kw. sets have forced lubrication. Oil rings are also provided as an auxiliary.

"My belief is that there ain't any boys left—that there isn't such a thing as a boy—that there's nothing now between a male baby and a man."—*Barnaby Rudge.*

## The Best Railroad Books

### Air Brake Catechism

By Robert H. Blackall. The new revised, 1907 edition, is right up to date and covers fully and in detail the Schedule E, T, Locomotive Brake Equipment, H-5 Brake Valve, SF Brake Valve (Independent), SF Governor Distributing Valve, B-4 Feed Valve, B-3 Reducing Valve, Safety Valve, K Triple Valve (Quick-Service) Compound Pump. It is the Standard Book on the Air Brake. Contains over 2,000 Questions and Answers on the Old Standard and Improved Equipment. Price, \$2.00.

### The Walschaert Locomotive Valve Gear

By W. W. Wood. If you would thoroughly understand the Walschaert Locomotive Valve Gear, you should possess a copy of this book, as the author explains and analyzes it in a most practical manner. Price, \$1.50.

### Locomotive Breakdowns

By Geo. L. Fowler. Tells how and what to do in case of an accident or breakdown on the road; includes special chapters on Compound Locomotives. Better procure a copy, as it contains 800 Questions with their Answers. Price, \$1.50.

### New York Air Brake Catechism

By Robert Blackall. The only complete treatise on the New York Air Brake and Air Signaling Apparatus. 250 pages. Price, \$1.00.

### Combustion of Coal and the Prevention of Smoke

By Wm. M. Barr. Contains over 800 Questions and their Answers on How to Make Steam. Price, \$1.50.

### Link Motions, Valves and Valve Setting

By Fred H. Colvin. Shows the different valve gears in use, how they work and why. Piston and slide valves of different types are illustrated and explained. A book that every railroad man in the motive power department ought to have. Price, 50c.

### Train Rules and Dispatching

By H. A. Dalby. Contains the standard code for both single and double track and explains how trains are handled under all conditions. Gives all signals in colors, is illustrated wherever necessary, and the most complete book in print on this important subject. Flexible leather binding. 221 pages. Price, \$1.50.

### The Railroad Pocketbook

By Fred H. Colvin. Gives clear and concise information on just the points you are interested in. It's really a pocket encyclopedia, fully illustrated, and so arranged that you can find just what you want in a second. 250 pages. Price, \$1.00.

## CHARTS

### Air Brake Charts

By Blackall. Shows passenger and freight equipment. Printed in ten colors. Price, 50c.

### Anatomy of a Freight Car Chart

(Box Car.) Has every part numbered and named. Price, 25c.

### Anatomy of a Freight Car Chart

(Gondola Car.) Has every part numbered and named. Price, 25c.

### Traction Power Chart

Shows the draw bar pull of any locomotive without a single calculation. Price, 50c.

### Anatomy of a Passenger Car Chart

Has every part numbered and named. Price, 25c.

Send for a special circular describing these books in full. Any of these books sent prepaid on receipt of price.

### AGENTS WANTED

Write for particulars.

The Norman W. Hanley Publishing Co.  
132 Nassau St., New York, U. S. A.

# The Superiority OF RUBEROID ROOFING

Registered U. S. Pat. Off.

For railroad uses is no better demonstrated than by the following letter:

"We have gotten better results from Ruberoid Roofing than any other roofing of this style which we have tried. In fact, where we must contend with *coal smoke*, we have decided that we cannot afford to use any other kind of composition roofing. B. S. WATHEN, Chief Engineer, "The Texas Pacific Railway Co."

Send for Prices and Samples.

**THE STANDARD PAINT COMPANY**  
100 William St., New York  
CHICAGO, ST. LOUIS, PHILADELPHIA, ATLANTA, BOSTON, KANSAS CITY, NEW ORLEANS.

## Ball's Official R.R. Standard Watches

16 AND 18 SIZE



17 and 21 Ruby  
Jewels,  
Sapphire Pallels

Ball's Improved  
Safety  
Double Roller

Are without question the finest watches that American talent and skilled labor can produce, and they are giving such universal satisfaction that we have no hesitancy in claiming that they are the best and safest railroad watch on the market.

Tests severe and numerous have proven this fact to the most critical

users in all sections of the country, to which thousands of good Railroad and Brotherhood men are ready to certify.

We have an authorized agent in nearly every railroad center. Call on him for information and facts. Write us for descriptive matter.

**The Webb C. Ball Watch Co.**  
Watch Manufacturers  
Ball Building, Cleveland, Ohio, U. S. A.

# Patents.

GEO. P. WHITTLESEY

MCGILL BUILDING WASHINGTON, D. C.  
Terms Reasonable Pamphlet Sent

### It Doesn't Do a Thing to Hose.

We have lately received at the office a very businesslike folder. It tells its story in short form and does not take up much time to do it. The writer of the folder has studied the kind of people to whom he appeals, for he says he has boiled down the description and leaves the cuts and the good sense of the reader to do the rest. The folder explains and describes the Twentieth Century Outfit made by Buker & Carr Manufacturing Company, of Rochester, N. Y.

This outfit, as they call it, is a small machine which does a number of things to air-brake hose, and evidently the machine is no respecter of persons, for one illustration shows a mechanic in the prime of life working away at it, another cut shows an old man making it go with ease and smoothness, and we have often been told that a boy can operate it and feel happy and gay as he should.

In the first place it is an air machine, about the size of a small lathe, and as a bolt cutter it is said to remove bolts from old air hose as fast as a man can feed them into its jaws. As a hose stripper its capacity is rated at 1,000 a day. It will pull old rubber hose off metal couplings at that rate, and old

cause its specialty is hose. The folder gives a good idea of the whole outfit. Drop Buker & Carr a post card to 19 Fairview Heights, Rochester, and they will send you the folder. It's worth looking at, anyway.

### Pleased with Modern Appliances.

At a meeting of railroad men we heard an old engineer commenting about the latest fashions of locomotives. As he had gone through the period of twenty-five ton locomotives he was naturally opposed to the one hundred-tons and over locomotive, but he favored most of the newer appliances for promoting steam economy and for convenience in operating. Strangely enough he had praise for the Walschaert valve gear and talked about the difficulty of reaching the valve gear of a consolidation engine. "As to piston valves," he remarked, "I like them first rate. The engines having them are easy to handle, but the only difficulty I find with piston valves is that the boiler can seldom make steam enough to supply the current that passes between the rings and the cylinder."

The Cleveland Twist Drill Company have purchased the business and entire stock of the Three Rivers Tool Company, Three Rivers, Mich. The machinery is being moved to Cleveland

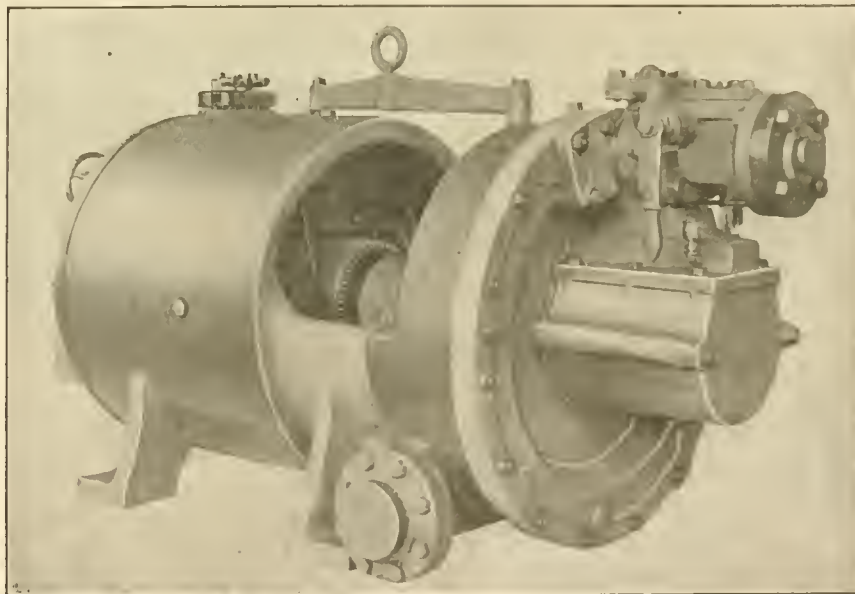

TYPE OF GENERATOR USED IN BAGGAGE CAR.

hose is a good hanger-on, every one knows. As a hose fitter, and here comes in the mechanic in the prime of manly vigor, it is reputed to fit up or mount 300 new hose per day, and new hose is stubborn, as anybody who has tried to work it can testify.

The machine is a hose cutter and a hose splicer into the bargain. The outfit weighs 1,000 lbs., occupies 2x6 ft. floor space, and stands 5 ft. 6 ins. high in its stocking feet. We say this be-

and with the new and fine equipment added to their already extensive manufacturing establishment the company hopes to meet promptly the rapidly increasing demands that are being made upon them. The latest important addition to the constant supply of novelties in tools is the Peerless Reamer, consisting of an elastic body to which blades of high speed steel are brazed, with the result that longer life and increased efficiency are given to the reamer. The

# Here's The Opportunity

## Are You the Man?

If an employer should say to you, "I want a man for an important position," would you be the right man? Opportunities like this are coming constantly to men trained by the INTERNATIONAL CORRESPONDENCE SCHOOLS, an institution that qualifies men to take advantage of every opening; to command high salaries; to succeed in the best positions.

Employers are daily applying to the Students' Aid Department of the I. C. S. for men to fill positions of responsibility, and during May of this year 447 students voluntarily reported advancement in positions and salaries, and this was but a small part of the whole number advanced.

Why don't YOU get in line for a good position? No matter who you are, what you do, or how little you earn, the I. C. S. can help you in your own home, in your spare time, for a better position and earnings. The first step is to mail this coupon. It costs nothing to do this and will bring you information and help that may eventually be worth thousands of dollars. MAIL IT NOW.

**International Correspondence Schools**  
BOX 805, SCRANTON, PA.

Please explain, without further obligation on my part, how I can qualify for a larger salary and advancement to the position before which is marked X.

General Foreman R. R.	R. R. Con. Engineer
R. R. Shop Foreman	Civil Engineer
R. R. Trav. Engineer	Bridge Engineer
R. R. Trav. Fireman	Chemist
Locomotive Engineer	Mining Engineer
Air-Brake Instructor	Architect
Air-Brake Inspector	Bookkeeper
Air-Brake Repairman	Stenographer
Mechanical Engineer	Ad. Writer
Mechanical Draftsman	French } With
Machine Designer	German } Edison
Electrical Engineer	Spanish } Phonograph

Name \_\_\_\_\_  
 St. & No. \_\_\_\_\_  
 Employed by \_\_\_\_\_ R. R. \_\_\_\_\_  
 City \_\_\_\_\_ State \_\_\_\_\_

reamer is made in all sizes and of two types, the one solid, the other expandible. The latter type is expanded by means of a plug threaded at the point with a taper seat near the top. The increase of diameter takes place at the point, and this admirable feature not only retains the cutting qualities of the reamer, but also makes it possible to retain the perfect taper after long service.

The Zephon Chemical Compound Company of Chicago have sent us a picture, which we here reproduce as a half-tone illustration. It practically tells the story. There is a huge cake of boiler scale. Roughly speaking it is 18 x 24 ins. by 3/4 in. thick and it was loosened up by the use of the Zephon boiler compound. This company does not treat all water alike. They are able to test samples of boiler feed water used in various lo-



BOILER SCALE 18x24 INS., 3/4 IN THICK.

calities, and after careful examination they make the particular form of Zephon boiler compound, which is suitable for the treatment of water corresponding to the sample. They say that they are willing at all times to make test, furnish the compound and guarantee results or take no compensation. They state that in some instances they have accomplished the feat of successfully caring for water at the low cost of 1 1/2 cents per thousand gallons and even less. They claim that they can clean and keep clean any scaly boiler, but do not attempt to treat foaming or priming water.

### Short of Paper.

"When the editor man of this paper," says a Western scribe, "was a 'bound boy' in Missouri forty years ago, his copy paper at school was so scarce that he had

# Tate Flexible Staybolt

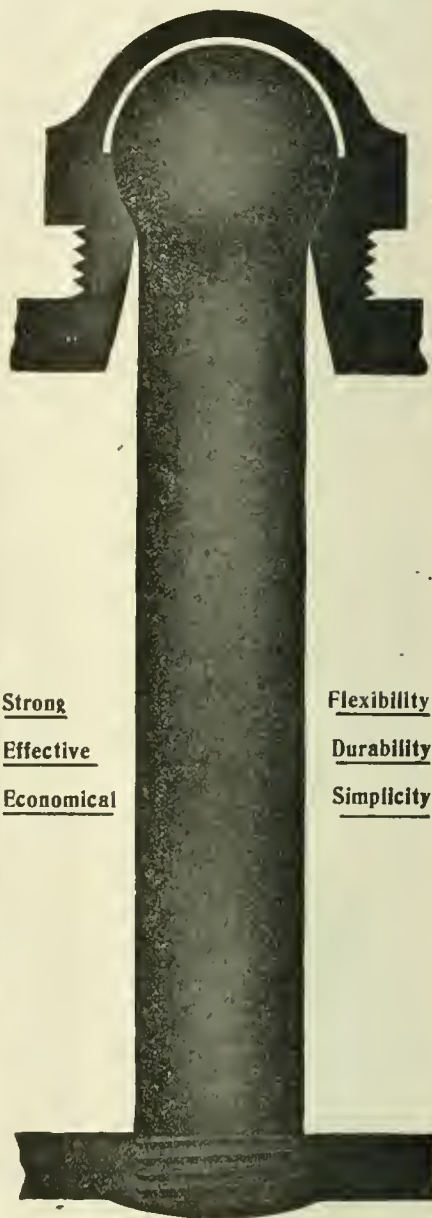

Strong  
Effective  
Economical

Flexibility  
Durability  
Simplicity

Holds firebox sheets securely together, and accommodates itself to the unequal expansion of the plates.

## FLANNERY BOLT COMPANY

PITTSBURG, PA., U. S. A.  
 Suite 308, Frick Bldg.

D. E. D. STAFFORD, - - General Manager  
 Write us for Reference Book

*Perfect*

Why pay more for a Car and Locomotive Cleaner, when the "PERFECT" will do the work and better at 48 cents per gallon, f. o. b. Philadelphia or Chicago?

THE MODOC SOAP CO.  
228 North Fourth Street  
PHILADELPHIA, PA.

**MICA**  
CABOOSE LAMP CHIMNEYS

Save 50 per cent.

STORRS MICA CO.,  
R. R. Dept. Owego, N. Y.

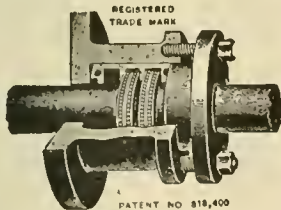

PAT. NO. 488,177	PAT. NO. 658,281
" " 800,890	" " 654,849
" " 834,104	" " 725,369
" " 803,920	" " 775,184
" " 775,168	" " 724,490

**NO MORE BILLS for PACKING**

No Cutting of Rods  
Less Oil. No friction

Guaranteed 3 years. 30 Days' Trial  
No Pay unless Satisfactory  
Beware of Imitations. Use the Best

Manufactured only by

**Holmes Metallic  
Packing Company**

Wilkes-Barre, Pa.

Send for Catalogue K

**THE WASHBURN CO.**  
Minneapolis, Minn.

**Automatic Couplers**

For Freight, Engine and Passenger Service

to write on both sides of the paper, and then crosswise of the first writing, to save paper. Although the paper we now use for copy costs only 3 cents a pound, our early experience will not permit any waste without annoyance."

The editor of RAILWAY AND LOCOMOTIVE ENGINEERING was even more embarrassed than his Missouri compeer when he was first moved to record his thoughts in writing. He lived on the Grampian Hills and was compelled to use the margins of newspapers. On such material he put down thoughts in verse at great length and his efforts might have rivalled those of Homer had an unappreciative servant not used the fugitive manuscripts for kindling the morning fires.

Rigid Turret Lathes is the subject of a catalogue recently got out by the Niles-Bement-Pond Company of New York. The lathes are called Pond rigid turret lathes in order to make the name distinctive. The catalogue is illustrated by a number of excellent half-tones and the descriptive letterpress is most complete. The tools are designed to do the work ordinarily produced by engine lathes. Two sizes are regularly made, 21 and 28 ins. respectively, though special sizes could be arranged for. The machines are well designed and solid and of course the turret is one of the principal features. The triangular shape in which the turrets is made afford three very wide faces, which allows of the heaviest facing, multiple turning and forming tools to be rigidly supported. Narrow faces are used for boring bars and reamers. The turret revolves on a circular V-way of large diameter, with means for taking up wear. The turret turns automatically and has rapid power traverse in either direction. Short rigid facing tools and short boring bars can be used, as the design of the cross carriage is such that it can be run under the chuck and is thus entirely out of the way of the turret. The machines and their parts are all illustrated and a perusal of the catalogue gives one an excellent idea of what the Pond rigid turret lathes are like. The company will be glad to supply this catalogue on application to their New York office.

Prosperous Erie.

The interesting and salient points of the Erie Railroad's operations for the fiscal year 1906-1907 are recorded in a report to the stockholders, which was submitted at the October meeting. The management shows increased gross and net earnings, both exceeding that of any previous year, a reduced cost of operation, a larger merchandise and coal tonnage, a greater rate per ton per mile, more passengers carried at a less

**Locomotive  
Blow-Off Plug Valves**

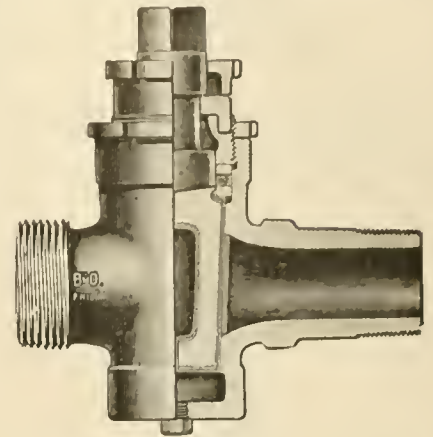

All Brass, extra heavy, with Cased Plug.  
For 250 lbs. pressure.  
Made with Draining Plug to prevent freezing.

**LOCOMOTIVE  
GAUGE  
COCKS**

For High Pressure



Bordo Self-Closing Gauge Cocks, made with renewable Hard Bronze seat and disc. Opened and closed with a quarter turn. Guaranteed Steam tight under the most exacting conditions. Shanks Threaded to specifications for Locomotives.

Seats and discs replaced under pressure.

**Swing-Joints and  
Pipe Attachment**



May be applied between Locomotive and Tender.  
These Swing-Joints are suitable for Steam, Gas, Air, Water or Oil.

Complete Booklet on Application

**L. J. BORDO CO.**  
PHILADELPHIA, PA.

# Homestead Valves

Straightway, Three-way and Four-way, and

# Homestead Locking Cocks

Are Famous the World Over

They cost more, but are worth very much more than other makes. You try them and see.



Brass, 1 1/2 in.



Iron Body, Brass Plug, 1 1/2 in.

**HOMESTEAD VALVE MFG. CO**

WORKS: **HOMESTEAD, PA. PITTSBURG, PA.**

## American Locomotive Sander Company

13th & Willow Sts., Philadelphia, Pa.

Proprietors and Manufacturers

LRACH, SHREVE, DEAN, SANDERS  
HOUSTON, "SHE" and CURTIS

**THE ROBERT W. HUNT & CO.**

Bureau of Inspection, Tests and Consultation,  
1137 THE ROOKERY, CHICAGO.

66 Broadway, New York.  
Park Building, Pittsburg.

31 Norfolk House, London, Eng.

Inspection of Steel Rails, Splice Bars, Railroad Cars, Wheels, Axles, etc. CHEMICAL LABORATORY—Analysis of Ores, Iron, Steel, Oils, Water, etc. PHYSICAL LABORATORY—Test of Metals, Drop and Pulling Test of Couplers, Draw Bars, etc.

Emergency Tests of Bollers, Engines and Locomotives.

rate per mile, an increased number of tons per train, more earnings per freight train mile, increased rates of wages, a greater amount spent for maintenance of way, a smaller amount for maintenance of equipment, a heavy increase in taxes, mostly in New Jersey, and no loss of life to one of the 24,199,723 passengers carried.

During the year 161 industrial establishments were located on the line of road, 89 of which have direct side track connections. In addition, 42 industries were located where they are reached by paying switching charges to other companies. Side tracks have been constructed to 14 industries not heretofore reached, and side tracks extended at 42 industries, previously located, to take care of increased business.

### Noisy Street Cars.

There is frequently cause for public complaint on account of the prevalence of extreme locomotive whistling. That is a noise that naturally suggests complaint, but there are other noises endured without a murmur that harass a much greater number of people than that of whistling. One of these is the noise of street car wheels. On some lines the rolling stock is so poorly maintained that a large percentage of the wheels are flat. They create a most irritating noise, but it is endured without complaint because most people believe it to be a necessary evil in connection with the operation of the cars. Nuisances connected with street car operating are endured without a word, while less irritating annoyances due to surface railroads raise howls of protest.

The Cutler-Hammer Manufacturing Company of Milwaukee announce the purchase of The Wirt Electric Co., and desire to state, for the information of customers and those of The Wirt Company, that the manufacture of Wirt apparatus will be continued by the purchasers. Pending the introduction in the Cutler-Hammer catalogue of apparatus of the Wirt type, the current Wirt catalogue should be used. Copies of this catalogue may be obtained from The Wirt Electric Company, Philadelphia, The Cutler-Hammer Manufacturing Company, Milwaukee, or on application to any of their district offices. Particular attention is called to the very complete line of battery charging rheostats developed by The Wirt Company, and to the Wirt field rheostats, which in 1902 were awarded the John Scott medal on recommendation of the Franklin Institute of Pennsylvania. Bulletins covering these and other lines of Wirt apparatus will be furnished on application. The Cutler-Hammer Company have an office at 136 Liberty street, New York.

# One Year and Eleven Months' SERVICE

WITHOUT REPACKING, ON

## High-Pressure Locomotives

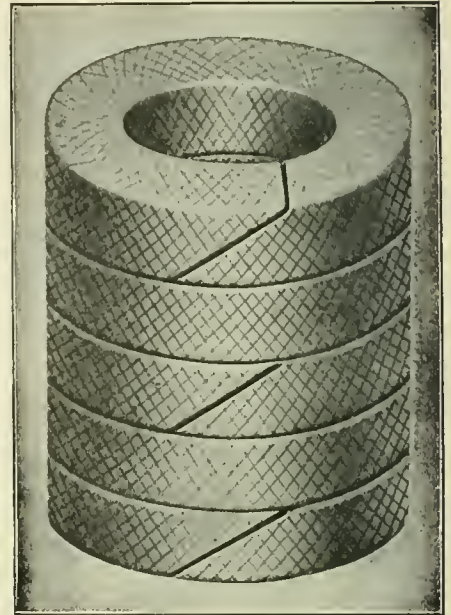

Style 300 TV.

A throttle failure is an absolute impossibility where Crandall's Throttle Valve packing is used.

IT WILL NOT BLOW OUT

## Crandall Packing Co.

FACTORY AND GENERAL OFFICE  
**PALMYRA, - - NEW YORK**

BRANCHES

New York  
136 Liberty St.

Cleveland  
9 So. Water St.

Chicago

52 West Washington St.

## Directory of Railways of the World

The Universal Directory of Railway Officials, published in London, contains a list of the entire railroads of the world, with physical particulars and names of all officials.

Send Your Order Now

for the 1907 edition.

Price \$4.00 Prepaid

**A. FENTON WALKER**

Sole Representative for U. S.

148 Liberty St. New York

**THE TANITE CO.**  
**seeks the support of**  
**Railroaders because:**

The man who uses a TANITE wheel will find it safe. Because pay for a TANITE wheel secures the greatest productive capacity. Because TANITE MILLS EMERY is mined in America and appeals to all who earn wages in America. Because TANITE grinding machines are practical.

THE TANITE CO. sells Emery, Solid Emery Wheels, Buffing Lathes, Guide Bar Grinders, Car Brass Grinders, Bench and Column Grinders, Surfacing Machines, Open Side Emery Planers, Saw Gummers, Automatic Planer Knife Grinders, Diamond Tools, Polishing Paste for Brass and Nickel, Emery Wheel Cutters and Dressers.

*The Tanite Co. builds special machines for special wants*

**THE TANITE CO.**  
**STROUDSBURG, PA.**

**THE UNION**  
**SWITCH & SIGNAL**  
**COMPANY**

**CONSULTING**  
**AND MANUFACTURING**  
**SIGNAL ENGINEERS**

**Automatic Block Signals—Electric**  
**and Electro-Pneumatic**

**Interlocking — Electric, Electro-**  
**Pneumatic and Mechanical**

**Electric Train Staff Apparatus**

**General Offices and Works at**  
**SWISSVALE, PA.**

**DISTRICT OFFICES:**

**NEW YORK - - 143 Liberty Street**  
**CHICAGO - - - Monadnock Block**  
**ST. LOUIS - - - Frisco Building**

**Oliver Lippincott**  
**Photographer**  
**20 John Street, New York**  
**Process and Mechanical Prints**  
*Perfect reproduction from Trackings, Black Lines, White Paper, any size, for Specifications and Estimates.*

**Pennsylvania Equipment.**

The Pennsylvania Railroad's lines east of Pittsburg have 952 locomotives more than they have passenger cars, according to the annual report of the general manager. There are in service upon these lines 4,099 locomotives and 3,147 passenger cars. In 1906 the number of locomotives was increased from 3,862 to 4,099. Of these 205 were added to the equipment of the Pennsylvania Railroad proper, 27 were placed on the P. B. & W. R. R., and 5 on the West Jersey and Seashore Railroad. Eighty-six old locomotives were sold during the year, and 43 were scrapped. It is also stated that in 1906 it required 207,606 new steel wheels for Pennsylvania Railroad cars and locomotives, 21,843 new steel axles and 6,638 new steel tires. The record of 1906 shows that at the shops of the Pennsylvania Railroad there were 235 locomotives built, 149 passenger cars, 2,124 freight cars and 76 maintenance of way equipment cars built. Repairs were made on 14,641 locomotives, 55,351 passenger cars and 2,689,679 freight cars.

Bulletin No. 4002 recently issued by the S. F. Bowser & Co., Inc., of Fort Wayne, Ind., is devoted to that company's system of oil storage, as especially adapted to the needs of railway storehouses, terminal signal towers, etc. It describes in detail the construction of the different styles of tanks, pumps and accessories manufactured by the Bowser Company, and is profusely illustrated with half-tones of some of the larger railroad installations which they have made, together with several suggestions for oil storage systems. The bulletin emphasizes the safety, economy, convenience and cleanliness of the Bowser system, and lays especial stress upon its flexibility, since it is adapted to both the largest and smallest requirements and can meet any local condition which might arise. Upon application to S. F. Bowser & Co., Inc., Fort Wayne, Ind., copies of this bulletin will be sent to any address.

**A Wash-Boiler Helped.**

A swarm of bees clustered on the handle of a major switch in the railroad yards here to-day, and for half-an-hour tied up traffic on four railroads and the Standard Oil Company, which had a train of tank cars stretched across the yards, was impotent. Half a hundred trainmen and trainmasters and yardmasters galore stormed and fretted, but the swarming bees buzzed merrily, and clung to the switch handle. A small boy in the gathering crowd took in the situation.

"My pop can get them bees off'n there," he volunteered.

**The Twentieth**  
**Century**  
**Master Mechanic**

Won't use Solid Mandrels.  
Cost too much, take up too much room and don't give satisfaction.

**Nicholson**  
**Expanding Mandrels**

Take everything from 1 to 7 inch holes. Take up little room—always ready and you can buy four sets for the cost of one of the solid kind.

**Are You Using Them?**

Catalogue tells you more about them.

**W. H. Nicholson & Co.**  
**Wilkesbarre, Pa.**

**STANDARD MECHANICAL BOOKS**  
**FOR ROAD AND SHOP MEN**  
**BY CHAS. McSHANE.**

**The Locomotive Up to Date**

Price, \$2.50

**New York and**  
**Westinghouse Air Brakes**

Price, \$1.50

**One Thousand Pointers for**  
**Machinists and Engineers**

Price, \$1.50

All books bound in flax cloth.

AGENTS WANTED everywhere; write for terms and descriptive circulars. Will be sent prepaid to any address upon receipt of price.

**GRIFFIN & WINTERS**  
**171 La Salle Street, CHICAGO**

"Go get him," chorused the division superintendent and the yardmaster. "Pop" came and deftly stuffed the bees into a wash boiler and carried them home. Traffic was resumed.—*Sioux City special in Philadelphia North American.*

The House of Lord's, by which we do not mean the famous upper chamber of the British Parliament, but the G. W. Lord Company of Philadelphia, Pa., have recently sent us a circular in which they make the proposition to intending customers that they will analyze boiler scale, and will forward a very useful little book called "Lord's Kinks and Receipts." This book has 387 pages and tells how to quickly make repairs to stationary engines, and how to do a host of things which have constantly to be done in the engine room or power plant of a railway repair shop or factory. The book is illustrated with numerous line cuts and has been edited and arranged by Mr. W. O. Rogers. There are a number of handy engine-house receipts to be found in the pages of the book and it is of handy pocket size. The way to get the book is to send a sample of the scale formed in the boiler or boilers you are concerned with, to the Lord Company, and the book is yours. The company's offices are at 2250 North Ninth street, Philadelphia, and a ready response will be given to those who communicate with them.

The Safety Car Heating and Lighting Company of New York have issued a very interesting catalogue of electrical appliances furnished by them. This catalogue treats principally on car lighting by axle driven dynamo. This system was exhibited at the Electrical Show recently held in New York. The car lamps and fixtures exhibited included the latest designs of combination fixtures with electricity and the new Pintsch single mantle lamps.

The Safety Co., realizing the demand for electricity on private cars and some of the "de luxe" trains, have spent over fifteen years in laboratory and service tests in developing the system of electric light illustrated and described in their catalogue. Everyone appreciates the necessity for a reliable driving mechanism, and the fact that the dynamo which they have placed on the market calls into use two belts to equalize the draw instead of one heretofore supplied is a point which this company emphasizes. The two belts in this system act in conjunction, but in case of derangement of either the remaining one is sufficient for the purpose.

The dynamo is constructed for large capacity and the regulator for maintaining a constant current for every increase of speed is simple and reliable. It is necessary to use storage batteries with all axle driven dynamo systems, and these batteries will discharge through the dynamo when the train is standing or running at a very low speed. To eliminate the possibility of difficulty from this source a main switch, very simple but of positive action, is used. The voltage of storage batteries varies about 10 per cent. for the range of their operation, and this 10 per cent. variation makes a perceptible change in the light and causes lamp renewals. In this system a simple lamp regulator is placed in the circuit between the batteries and the lamps. The Safety Company will be happy to supply information to those interested in this matter and will send a copy of the catalogue to anyone who favors them with a request. Their address is 2 Rector street, New York.

**Blow Pipe Contract.**

A large blow pipe contract has been awarded the Savannah Blow Pipe Company by the Central of Georgia Railway Company for a blow pipe and heating and ventilating system for their new shops being built at Macon, Ga. These shops will be as complete as it is possible to make them. The latest and most modern apparatus and machinery have been purchased, and when the ponderous turbines, which will be used for generating electricity, are put in motion, Macon and the State of

**Twentieth Century Outfit**

With stripping equipment in place, it will pull from their metal connections as many as a man can handle; like the bolt cutter, its capacity is limited only by the dexterity of the operator. For further information ask

**Buker & Carr Mfg. Co.**, 19 Fairview Heights, Rochester, N. Y., U.S.A.

**FROM HAND CARS TO EXPRESS LOCOMOTIVES.**  
 Drawings for all kinds of railroad machinery a specialty.  
**SIDNEY C. CARPENTER**, Draftsman and Designer  
 PLAINVILLE, CONN.

Georgia will have within their borders one of the most up-to-date railroad shops in this country. The Savannah Blow Pipe Company recently secured a contract for the new shop of the Atlantic Coast Line Railroad at Waycross, which are fast nearing completion.

**CONTENTS.**

*Bombay-Poona Mail.....	481
Rubber from Peat.....	482
Traveling Engineers' Convention.....	484
*Curiosities of Locomotive Design.....	487
*Seventy-Five Ton Flat Car.....	494
*Floating a Railway Tunnel.....	495
General Foremen Attention.....	512
Among Railroad Men, by J. Kennedy.....	512
Book Notices.....	499
What is a Commutator? by Geo. S. Hodgins.....	501
Convention for Atlantic City.....	514
*The Boys at Jackson (M. C. R. R.).....	515
Machine Moulding.....	515
*Removable Driving Brass.....	516
*Train Lighting by Electricity.....	518
Doesn't Do a Thing to Hose.....	519
Pennsylvania Equipment.....	523
Departments:	
*General Correspondence.....	489
*Patent Office.....	507
Air Brake.....	505
Correspondence School.....	501
Questions Answered.....	503
Personals.....	513
Editorials:	
The Why of Superheating.....	496
Fitting Piston Rings.....	496
Inductive Reasoning.....	497
Both Parties Benefited.....	497
Smoke Prevention.....	498
Car Foremen Discuss Code.....	498
Santa Fe to Educate Apprentices.....	498
Locomotives:	
*Ten-Wheeler for the C. & S.....	483
*Rogers 4-6-2 for the A. & W. P.....	511
*Austrian Rail Motor.....	499
*Oldest Canadian Locomotive.....	500

**TOOL STEEL**

**Die Blocks  
Steel Forgings**

First Prize awarded at the Louisiana Purchase Exposition, at St. Louis, for our **TOOL STEEL** when placed in competition with the best makes in England and Germany.

Write for information and prices. Specify McInnes Tool Steel when ordering.

**McINNES STEEL CO.**  
 CORRY, PA.

Agents  
 SCHROCK & SQUIRES,  
 291 Pearl St., New York.  
 ROY MACHINERY CO.,  
 Minneapolis, Minn.



# Railway and Locomotive Engineering

Copyright by Angus Sinclair Co.—1907

A Practical Journal of Railway Motive Power and Rolling Stock

Vol. XX.

136 Liberty Street, New York, December, 1907

No. 12

## The "Black Diamond" on the Lehigh.

Whenever you see the representation of a small red flag, something like a U. S. Commodore's pennant, with a black centre made in the shape of a lozenge bearing the letters "L. V.," the whole surrounded with a wreath, that is the emblem of the Lehigh Valley Railroad.

Number 9 and Number 10 are the black diamond expresses, the odd number is the westbound train between New York and Buffalo, and No. 10 is the eastbound train. The time table distance between Jersey City and Buffalo is 447.6 miles and No. 9 goes over this distance in 613 minutes, or at an average speed of 44 miles

a renewal of the name first applied when the Black Diamond Express was inaugurated in 1896, 'The Handsomest Train in the World.' The train operates on its present fast schedule between New York and Buffalo, having a through coach from and to Philadelphia."

The train itself is about 315 ft. long



FAMOUS BLACK DIAMOND EXPRESS ON THE LEHIGH VALLEY.

On the flag the black diamond is a conspicuous figure, and on the road itself the "Black Diamond Express" is the most important train. The railway was in former days often thought of only as a coal road, and from this probably came the idea of the black diamond, but although the well known emblem has been retained, the road has long ago become one of the best passenger highways in the land.

an hour. The train consists of one baggage and library car, two day coaches, a dining car and one Pullman parlor car with an observation end. The equipment, put on last month, is entirely new, and we are informed that "This new equipment has been constructed from plans especially designed to provide the acme of comfort and safety, and the builders have put upon it the very best skill, resulting in the production of a train which warrants

over all and with engine and tender attached will occupy about 388 ft. of Lehigh Valley track; but at the average speed made, this whole train would take just about 6 seconds to pass a person standing by the side of the track. The estimated weight of the train, without engine and tender, is 599,770 lbs., so that if a 230-lb. man stepped on board the train would turn the scale at 300 tons, supposing there was a scale large enough

for it to turn. The baggage and library car weighs 116,600 lbs.; the two day coaches each weigh 117,660 lbs.; the diner weighs 131,850 lbs. and the parlor car 116,000 lbs. The train, therefore, without engine and tender, weighs about 600,000

advertising department. The coaches are lighted by electricity, with Pintsch gas as a reserve, and are heated by direct steam from the engine, the Gold system being used.

The Black Diamond engines are fine

mountains; but from the traveler's standpoint it is the most enjoyable, as it is the most picturesque of any.

At the time that the photograph was taken, from which our frontispiece half-tone is made, the Black Diamond express was headed by an Atlantic type engine, and only four cars were hauled. At the present time these trains are made up of five cars and are hauled by engines of the Pacific, or 4-6-2 type, and one of these handsome machines is represented among our illustrations. For this engine and the information concerning it we are indebted to Mr. F. H. Hibbits, the superintendent of motive power of the road. The engines have cylinders 22 x 28 ins.; driving wheels, 76½ ins. diameter; the tractive effort is about 28,340 lbs. The engine in working order weighs 241,360 lbs. and with the tender weighs 384,510 lbs. The train, with the engine and tender to be exact, weighs in all 984,280 lbs., or about 492¼ tons. The total heating surface of the boiler is 3,858 sq. ft.

Suppose the train was on the average 9 ft. 11 ins. wide all along, counting engine and tender. As a matter of fact, it is not quite so wide, but for sake of example suppose it was. The shadow of it on the ground with the sun straight overhead would in area about equal the total heating surface which is tucked away in the tubes and fire box of this engine.

#### A "Holy Terror" Steamer in the Hands of Jim Skeevers.

BY JOHN A. HILL.

Skinny Skeevers, him of the object lessons, ran Mike Monnihan's engine for a long time, while Mike went to visit the "ould sod," and Skinny's engine got a new firebox and a coat of varnish.

The first time Skinny oiled around, he yelled up to Patsy Killigen, the fireman, to put on the injector, and cool her off,



TYPE OF COACH USED ON THE BLACK DIAMOND EXPRESS.

lbs., and at its average speed of 44 miles an hour it moves over 3,872 ft. in each minute.

The Lehigh Valley trains pass through a most beautiful part of the country, and the scenery along the road, especially where it passes through the mountains, has been called the Switzerland of America. The high lands in Virginia and Pennsylvania are called by the general name of the Allegheny mountains. At Easton the Lehigh river joins the Delaware river and this junction of water was called by the Indian word *lechawekink*, which means "where there are forks," and this curious word has been corrupted into Lehigh. The valley of this river is followed as far as White Haven, where the line strikes across to the Susquehanna valley at Wilkesbarre. At Lehigh Gap the road winds round the end of the Blue range, and at Pen Haven it passes through the Pohopoko mountains.

Our frontispiece illustration shows the Black Diamond Express bowling along beside the Susquehanna river, near Towanda, Pa. Some of the names of the towns along the line are interesting in their origin. Towanda, for instance, is an Indian word, pure and simple. Sayre, close to the State line between New York and Pennsylvania, was named after R. S. Sayre, at one time chief engineer of the road. Wilkesbarre was named in honor of two members of the British parliament who were noted American sympathizers. They were John Wilkes and Colonel Barre. Mauch Chunk is from two Indian words, *machk*, meaning bear, and *tschunk*, mountain. Scranton comes from the name of the late Mr. J. H. Scranton. Tunkhannock is from two words used by the Delaware Indians and means small stream.

Our illustrations of the train itself, the coach and the view of Mauch Chunk, were made from photographs kindly given by Mr. B. F. Hardesty, chief of the ad-

vertising department. Three engines are required for the run from Jersey City to Buffalo. The first section is from this terminus to Easton, a distance of 77 miles; the next run is from Easton to Sayre, a distance of 194 miles; and the



cleanest railroad." Three engines are required for the run from Jersey City to Buffalo. The first section is from this terminus to Easton, a distance of 77 miles; the next run is from Easton to Sayre, a distance of 194 miles; and the

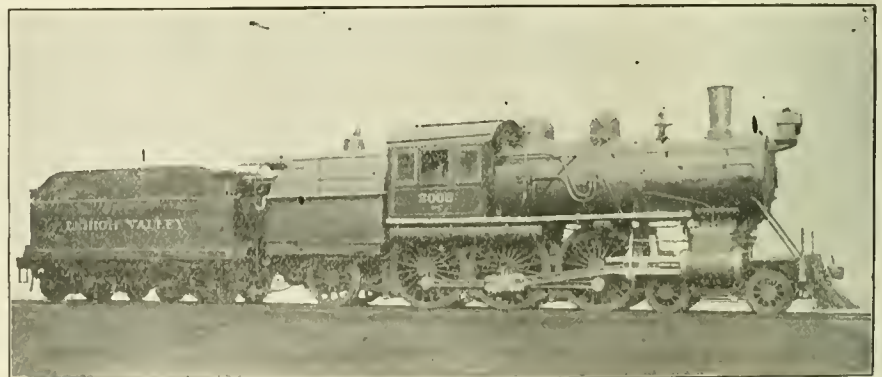

BLACK DIAMOND 4-6-2 ENGINE USED AT THE PRESENT TIME.

last is between Sayre and Buffalo, 176.6 miles. The time allotted to each engine is: for the first, 96 minutes; the second, 287 minutes; and the third, 230 minutes. The middle division is the longest and the hardest, as in it the road crosses the

so he could see the oil holes; she was howling so it gave him the blind staggers.

"How does she steam, Patsy?" asked Skeevers, as they started out.

"She's a 'holy terror' for wind," said

Pat, proudly. "She's always crazy wid it."

Skeevers was somewhat annoyed at the constant howl of the pop, but it did little good to speak to Pat—Pat fired by the pop, and a "holy terror" was his ideal.

Skeevers thought he'd try an object lesson.

"What size nozzle has she got?" asked Skeevers.

"Oh, Lord! you ain't agoin' to go monkeying with her nozzles, are ye, Skeevers? They are 2½ or 3-inch now."

"She burns too much coal, and howls too much."

"There hain't another steamer like her on the road," moaned Patsy. "Why, you can't shut off her throttle, but up goes her white tail—steam! Why, she's the darlin' of 'em all, Skeevers."

Skeevers got a smaller scoop, but Patsy plied it industriously, and the "96" still held the first prize as a "holy terror" for steam.

Skeevers bribed the coal shovelers to put on a tank load of lumps, none too weigh less than 200, but Pat paralyzed the lumps and reported the coal shovelers beside.

Skeevers thought of putting a flat car between the engine and tender, but gave the idea up as impracticable.

Patsy would put in a fire within two minutes of a regular stop, and be happy when the black smoke rolled, and the white feather stood proudly up 48 feet above the howling pops of the "Holy Terror." Skeevers was in despair.

"Pat, did you ever stop to think that you are shoveling a lot of coal through that pop for nothing?" he asked.

"I don't mind the work, Skeevers," said he. "Don't mind it a bit; it makes the other lads green wid envy to see how she do steam."

"But it wastes coal."

"Bless ye, me boy, the company own their own mines, and it's proud they ort to be to have such steamers."

Skeevers couldn't get Patsy mad, and could awaken no other feeling in his heart but worshipful admiration of the prolific steam production of the "Holy Terror."

The run was a light passenger one, and after some scheming Skeevers got Pat on the "Holy Terror" on heavy freight run for a week. Skeevers managed to use all the steam that was made on the road, but Pat insisted on a pop solo at every stop.

Skeevers hated to disturb the front end adjustment of another man's engine; he finally determined to enlarge the nozzles, but concluded that this might give them trouble on the road, and besides that, Skeevers didn't believe in patching an engine to repair a man, any more than he believed in feeding a fireman soda ash to keep scale out of a boiler.

But right here the road got a new master mechanic, and the very first month he

put up a bulletin of the amount of coal burned on each engine, and the "Holy Terror" was away down in the middle of the passenger engine list.

Pat was pretty mad about it, and said, if they would figure on who made the most miles or the most hours with the steam pressure at or above 140, he and the "Holy Terror" would take first money.

The next month he stole a few lumps of coal, gave the shovelers cigars for big measure, etc., but the bulletin appeared again with the "Holy Terror" advanced but one point.

Then came a bulletin notice that firemen would be promoted on merit, especial preference given for a coal record.

Pat had a nightmare that night when he thought of the "Holy Terror" and himself at eighth place, and Jim Bean.

"Holy Terror" was at the head, and the "94" was fifth. Pat was improving some.

Pat was glad to get back with Skeevers and the "Holy Terror"—said Old Man Martin on the "94" kept "picking at him" about opening the door and monkeying with the dampers.

Jimmy Bean was sent to running switch engine in a week or two, and Patsy's heart was broken.

"Skeevers," said he, "I'm disgraced. What the devil is the matter with the '96,' or—or—me?"

"The '96' is, without a doubt, the best engine on the road, Patsy," said Skeevers, "and honestly I think you are the best fireman, or rather would be the best, except that you haven't figured out plainly just what you are trying to do—you don't realize what you burn the coal for."

"To make steam, of course," said Patsy.



BIRD'S EYE VIEW OF MAUCH CHUNK ON THE LEHIGH VALLEY.

who was hired four months after he was, leading the list for coal—and promotion.

That evening after they got to going up the hill, and the pop sat down to rest a minute, Skeevers called Pat over, and, in a friendly way, told him that the Old Man had said he should have to promote three or four men in the fall, and that he was afraid that Pat would lose his chance and see a lot of younger fellows pass him, if he didn't mind. Skeevers suggested that the main trouble was with the "Holy Terror," and not Pat, and proposed that they prove it to the Old Man by having Pat transferred for one month to the "94," that was then leading the coal burners.

Pat agreed to this if Skeevers would arrange it—he didn't know that Skeevers had arranged it.

When the next bulletin came out, the

"What do you want of the steam?"

"To pull the cars av course."

"Where do you put it for that?"

"Into the cylinders, surely."

"Suppose you have more than you want?"

"Out of the pop she goes—can't hurt nothin'."

"But the coal pile?"

"Coal pile?"

"Yes, don't it take as much coal to make steam to blow through the pops as it does to make the same amount of steam to be used in the cylinders?"

"But there don't much go out of the pops."

"That's where your mistake has been, Patsy. Pop Martin told me this mornin' that if he had all the steam that the '94' made and wasted at the pops while you were on her, he could make

four round trips without coal or water."

Pat put in a fire and gave a big lump a few vigorous whacks with his coal pick, and then came back.

"I've a notion to quit, Skeevers," said he.

"You fire this engine the best you know for another month, take my advice, and if she don't head the list, I'll quit," said Skeevers.

"You want to remember that in making steam to throw away, you not only waste fuel to make it, but you waste water. Water is cheap, but it takes coal to haul it around, and the '06' takes more water than the other engines do, and hauls many tons of it a month for nothing; then we have to stop for water oftener, and that takes coal—takes coal to stop and coal to start."

"Coal to stop! How d'ye make that out?"

"There you are again, Pat; you see you haven't figured on your business or followed cause and effect up very much. Don't you know that it takes just as much

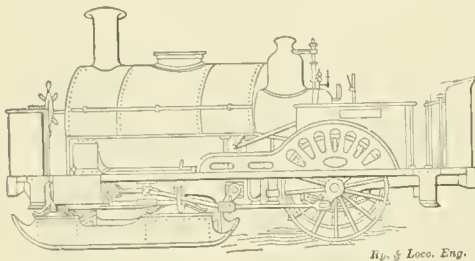

FIG. 31. GREW'S ICE LOCOMOTIVE FOR RUSSIA, 1861. (Described on page 539.)

power to stop a train, leaving out friction, as it does to start it?

"When you set the brake it commences to use up and lose 'stored energy' that has been put into the train by the coal, through the medium of the cylinders.

"Then your brake will use more steam to get its pressure back again, and the '06' will get rid of more coal to get the train back into motion, and use more to haul the extra water. It all counts, Pat, because we do this all day, every day in the month; if it was only once it wouldn't amount to much. Think about your work, and figure on how little you can do in the way of coal shoveling to get this train over the road, and I will bet on the result."

Last Thursday the new bulletin was put up. The "Holy Terror" stood at the head, and Patsy Killigen hummed "Comrades" as he was polishing the hand-rail in the roundhouse, when the Old Man came along, touched Pat's leg with his umbrella, and said:

"Come into the office after dinner—I want to talk with you."

Of all fruitless errands, sending a tear to look after a day that is gone is the most fruitless.—*Nicholas Nickleby.*

### Among the Railroad Men.

BY JAMES KENNEDY.

AT LIMA, OHIO.

The railroad repair shops of the Lake Erie & Western railroad, now a branch of the Lake Shore and Michigan Southern, are crowded to the doors with the repair work incident to the rapidly expanding traffic of that section. Mr. John Hill, master mechanic, and Mr. W. H. Sloat, general foreman, manage to keep 600 men busy in the limited space, and the splendid locomotives are in excellent condition. Extensive additions are already in contemplation, and meanwhile everything is done in the way of heating and ventilating the quarters with a view to add to the comfort of the workingmen. Mr. C. A. Keller, clerk in the master mechanic's office, spoke warmly of RAILWAY AND LOCOMOTIVE ENGINEERING and declared that it was the only engineering paper seen about the works.

The shops of the Ohio, Hamilton and Dayton Railroad at the other end of the city are a fine example of the last century type of repair shop kept up to date. Mr. Hinckley, master mechanic, has about 300 men at work, and the fine passenger engines are in excellent condition. They are mostly of the Brooks build, with a few Baldwins. Mr. Hinckley does not seem to have much faith in the piston valve type of engine. They were conspicuous by their absence. Mr. J. J. Kelker, assistant master mechanic, and Mr. J. L. Mumaugh, his chief clerk, ably supplement Mr. Hinckley's work.

AT HUNTINGTON, IND.

Mr. W. F. Yergens, division master mechanic on the Erie Railroad at Huntington, Ind., is a fine type of the frank, open-hearted master mechanic of the older school. He has been very busy changing sixteen of the Vaucrain compounds to simple engines. He is going back to first principles as rapidly as he can and the transformed locomotives certainly looked the perfection of mechanical construction. It was no easy job. The front ends of the frames had to be reconstructed and adjusted to the new cylinders and saddle. Mr. Yergens was loud in the praises of the device of the Talmage Manufacturing Company, who had fitted the locomotives with a water purifying or scale preventing device. The waters of the Little Wabash River are full of the hardest kind of limestone and in a few days the shell of a boiler is lined as with a wall of brass. A gallon of Talmage's specific is injected for every 125 miles run. Five blow-off cocks located in different parts of the boiler are opened at intervals and the boiler is so clean that it is only wasting time to go through the operation of washing the boilers once a month. Mr. Yergens has a blackboard in the round house that should be patented. It has nearly as

many squares in it as the multiplication table. Every square has a box and every box is adapted to hold the properly filled notice in regard to some particular repair that is expected to be made. When engineers come in with their garrulous grumbings, there is nobody will listen to them. Write it down and put it in the proper box and the skilled mechanic comes along and there is no loose talk. It was hard on the engineers at first. The idea of an engineer holding his tongue at the end of a trip was something terrible, but they are getting used to it, and silence has fallen upon them like a benediction.

AT CHICAGO.

The Queen City of the Lakes seemed resting under a dark cloud which became blue as you approached, and when the muffled sunshine broke through, the sombre mantle became darkly glorified, like copper dust. We are in the region of soft coal and the colossal buildings look dim and shadowy as Ossian's ghosts. The great railways converge here like the center of a spider's web. At the shops of the

CHICAGO AND NORTHWESTERN RAILROAD

where 1800 are employed there is an elegant vastness that gives one the impression of being in a national exhibition of railroad machinery. Not only are the largest and best machines at work here, but they are kept in fine condition, giving an air of newness to the whole that is not common in every railroad shop. This is especially the case with the turning lathes, many of which are electrically driven, the motors being very compactly located in the frame of the lathe, which has many advantages over the superimposed structures towering overhead and obstructing the ready transit of material on the travelling cranes. A large 8 ft. boring mill was turning out six tires an hour, one man readily manipulating the placing and boring and removing. The Walschaerts valve gear has already made a very favorable impression in the mechanical department. Five engines equipped with the gearing are on hand and ten more are expected in a few weeks.

We had the opportunity of observing the welding of a locomotive frame that was broken between the front pedestal jaws. Mr. H. D. Kelley, the company's accomplished demonstrator, was in charge of the operation, and with two assistants the work was speedily performed. The front driving wheels had been lowered in the drop pit, the front spring and saddle removed and about half an inch of the frame cut out by drilling and chipping. A conical shaped crucible surmounted the mold which surrounded the frame. A screw jack between the pedestals slightly enlarged the amount of opening in the frame. The operation of heat-

ing the frame was accomplished by an air blast burning gasoline. The ends of the frame were nearly cherry red when, after carefully closing the opening where the hot air blast had been admitted, the thermit, which consists of equal parts of finely divided aluminum and iron oxide, was ignited and in a few seconds the crucible was full of liquid fire of intense whiteness and brilliancy. It appears that the chemical reaction between the ingredients of the crucible when ignited has a marvelous affinity for oxygen, inducing a temperature said to be 5,400° F. and has the effect of separating liquid steel from aluminum oxide, the steel being about three times heavier than the oxide or slag, the molten steel naturally finds its way to the bottom of the crucible. The fusing and settling of the compound did not occupy more than a minute and a half, a tapping pin was removed, and the liquid steel ran into the mold surrounding the fractured frame. It can be readily understood that the superheated steel has the effect of heating the exposed ends of the frame to a fusing point and thus a solid weld is accomplished. While cooling, the screw jack was loosened and points on the frame carefully measured with a fixed tram, the loosening of the jack having the double effect of aiding the natural contraction of the heated mass and also maintaining the exact longitudinal dimensions of the frame. It may be added that the metal formed in this way and at such a degree of heat is a low carbon steel, and the metal is said to be improved by adding a mixture of iron rivets, which were heated by the gasoline blast, in a separate receptacle, before being mixed with the thermit.

The employees in the shops are a fine looking body of men. Mr. Seavert, the chief clerk in the office of the superintendent of motive power, paid a warm compliment to the intelligence and sobriety of the men, who, it appears, are largely resident in the suburban towns that are some distance from Chicago, many of them owning their own homes and all of them enjoying the 51-hour a week regulation schedule, which allows some time for relaxation. A large number of firemen had just been examined for promotion and Mr. Seavert claimed that the most successful were the readers of RAILWAY AND LOCOMOTIVE ENGINEERING.

CHICAGO, BURLINGTON AND QUINCY ROUND HOUSE.

Some of the famous flyers on the C. B. and Q. were in the Chicago roundhouse, and they certainly looked the perfection of locomotive construction. One can scarcely credit the records made by some of these engines—79 miles in 72 minutes being claimed as an every day occurrence among them, but the flat lands of Illinois give a fine opportunity for a straight, level road, something altogether unknown in the East or furthest West. It was a

real pleasure to meet the foreman, Mr. J. H. Lewis, who has perfected several important inventions, among which is a piston packing already in use on a number of roads. It consists of a series of metallic discs, so separated that they touch each other with projecting points or tongues. The steam acts on the outer edges of the discs and closes them upon the piston. The wear of the inner edge of the discs by the piston is coincident with the wear of the little tongues that separate the discs, and so a continuous and perfect joint is maintained. When the engine is drifting there is no pressure upon the packing, the discs being held in place by coiled springs of small wire. The dies for forming the various sizes of discs, as well as the making of the minute coiled springs, are all of Mr. Lewis' contriving and stamp him at once

### Hydraulic Ram.

Any ordinarily intelligent observer will no doubt have noticed that peculiar sound accompanied with a slight shock in the water pipe leading to a wash basin when the water has been flowing freely and is suddenly shut off. The shock or blow takes place because the water, like other substances in nature, has weight, and when moving at a certain velocity has a definite momentum, which, though slight, cannot be destroyed without exerting some pressure at the moment when the flow is stopped.

This shock, not very heavy at any one time, it is true, would nevertheless damage the joints of the pipes in time. This is why water valves are, as a rule, made so that they shut off gradually, and in large water valves or gates there is often a by-pass valve beside the large one which



FIG. 30. ENGINE WITH OSCILLATING CYLINDER AND NO VALVE GEAR.  
(Described on page 539.)

as a clever mechanic. His latest patented improvement is a device for retaining the plugs in grease cups. This ingenious device we have illustrated and described in detail in another column of this issue.

According to the *Railway Engineer*, London, the assistant locomotive superintendent and works manager of the Midland Railway has been appointed general superintendent of the railway. This appointment has been made with a view of concentrating under one officer the working of the trains, and thus abolishing the friction which occasionally arises between the locomotive and operating branches. This is one more proof, if proof were needed, that a well trained and efficient mechanical department officer is capable of holding any post of responsibility in railway service and it often pays well to give such a man a chance.

is closed after the main valve has been shut. Many water valves have fine threaded screw stems so as to compel the gradual closing off of the water. The fact that the sudden stoppage of flowing water in a pipe or vessel gives rise to a more or less pronounced shock is made use of in various ways in the arts.

There is a method of raising water which is sometimes employed by railroad engineers who have charge of the water supply service, and the machine they employ is called the hydraulic ram. The principle upon which the ram works is that the body of water moving at a certain rate, when suddenly stopped, acts very much like a solid body and is capable of doing work. It is in a sense like the stroke given by a light hammer.

The hydraulic ram is simply a closed vessel with a supply pipe leading to it and a delivery pipe leading from it. The ram is usually placed beside or near a small stream of water and a slight fall

is given to the supply pipe so that water will constantly flow into the vessel which constitutes the body of the ram. A check valve is placed where the delivery pipe comes off from the ram, so that water may enter the delivery pipe, but cannot flow back. There is what may be called an overflow valve at one end of the ram which, while it remains open, permits water to flow out of the ram.

The action of the hydraulic ram is briefly that water enters through the supply pipe, fills the body of the ram and when the ram is full, water flows out of the overflow. This causes the overflow valve to slowly rise, as it has a comparatively long lift, and when it seats, it shuts off the flow, with the slight shock of which we have spoken. This shock is sufficient to unseat the check valve at the base of the delivery pipe and a small portion of water is forced up into the delivery pipe.

Having forced, as one might say, a cupful of water into the delivery pipe and the force of the blow being thus expended, the check valve seats again and so prevents the return of the water thus forced up. The small escape of water from the overflow having been stopped, the whole becomes momentarily quiescent. The space formerly occupied by the water forced into delivery pipe has now to be filled and the check valve, no longer under pressure, sinks down and water flows past it again, with the result that it is again

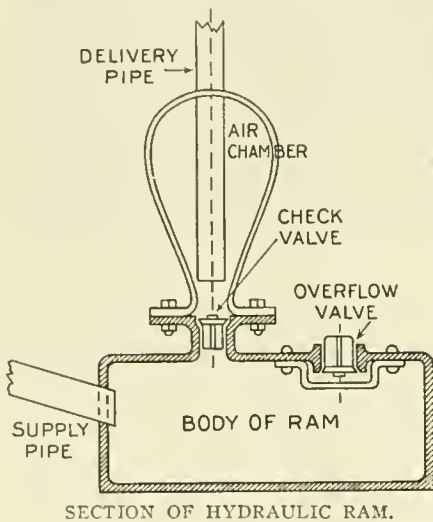

SECTION OF HYDRAULIC RAM.

carried up to its seat, when the vessel is full, a slight shock follows upon its seating, and a second cupful of water, we may say, is forced up into the delivery pipe. This succession of overflows, shocks and water delivery goes on indefinitely.

The delivery pipe has an air chamber at its base so that the slight compression of the confined air forms an elastic cushion for the water entering the chamber and it assists in the steady raising of the water. The action of the hydraulic ram is intermittent, that is, the delivery of the water is done by a series of impulses, but

the air cushion causes the flow into the tank above to be comparatively uniform and steady, like the jet of water from a pump equipped with an air chamber. A great deal of water is thrown away through the overflow and the amount delivered is comparatively small, but the machine is used only where there is a natural flow of water and where a small but constant delivery is required. The ram does not cease working when the tank is full, and it is usual to provide an overflow pipe from the tank which carries the surplus water back to the stream again.

#### Engineering Library.

On and after Wednesday, November 6, 1907, the reference libraries of The American Institute of Electrical Engineers, The American Society of Mechanical Engineers, and The American Institute of Mining Engineers, 29 West 39th street, New York, will be open every evening until nine o'clock on all week days except public holidays. These libraries constitute practically one library of engineering, and are situated near the New York city library. They are in the new headquarters of the Engineering Societies and are available to members of these societies, engineers and the public generally, subject to certain regulations. Strangers are requested to bring letters of introduction from members, or to secure cards from the secretaries of the respective societies.

#### Most Fortunate.

A man whose love of long words is superior to his method of pronouncing them took up the morning paper at breakfast the other day and began to read about a most peculiar railway accident. A train, having collided with a snag of some kind, had described a few parabolas in the air, turned turtle, dived into a river, and otherwise upset the plans of those who were running it. All the people at the breakfast table listened to the account with breathless interest. "What a terrible accident," said one. "There must have been a great many killed," remarked another. "No," said the newspaper reader, with the printed account still fresh in his mind, "there were no fatalities."

#### Cutter for Side Rod Holes

Our illustration shows the details of a very handy little device used at the Susquehanna shops of the Erie Railroad, and though Mr. H. H. Harrington, the master mechanic, does not claim to have invented it, yet the fact that this and other handy shop devices, several of which we have described, are used at the shops over which Mr. Harrington presides proves that expeditious methods of doing work is characteristic of his regime.

The tool is made with a No. 5 Morse standard taper shank, so that it will fit the socket used for any of the standard drills. A  $2\frac{1}{4}$ -in. hole is first drilled through the rod, and this hole serves as a guide for the cutter. After the guide hole has been cut, the drill is removed from the socket and this special device put in the machine. It will be seen from the construction of the tool that

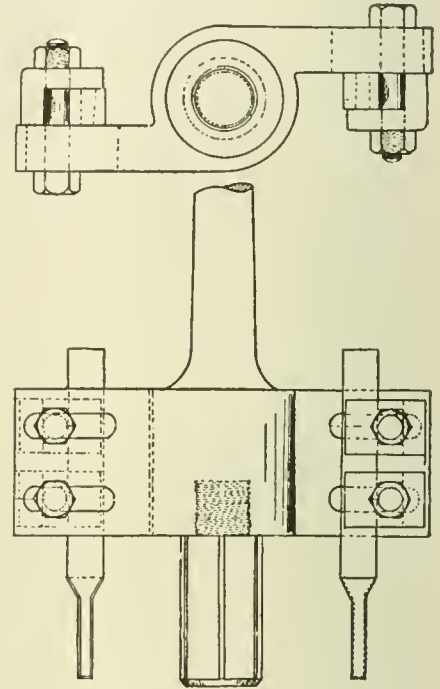

TOOL FOR CUTTING HOLES IN SIDE RODS.

a large circular block is cut from the rod, thus avoiding the necessity of drilling all the metal away. When the hole has been cut, the round block of metal can be taken out, and the hole in the rod-end is the right size for the bushing. The Erie people believe that the device is almost, if not quite, as good as a special tool built for the purpose and the first cost of this cutter is quite small.

The November number of the *Travelers Railway Guide* has now been in existence for the last half century. The Fiftieth Anniversary Number contains many reproductions of old railway maps showing the small beginnings of the great systems of to-day. These have been taken from the *Guide* of 1857 and are interestingly contrasted with maps of the present day. Some historical sketches of more than passing interest, a few illustrations of peculiar value and some comment on the great growth of the railways of this country in the last half a century, make this Anniversary Number worthy of preservation. Of special interest are the pages on old tavern days and stage coach times and early railways. The greatest hotel in the world is illustrated and described, and so also is the very old hotel at Rhinebeck, N. Y.

**Mallet Compound for Brazil.**

We recently illustrated and described a Mallet articulated compound locomotive of the Angus type, three of which were built by the American Locomotive Company for the Erie Railroad, which are accounted the largest and powerful locomotives in the world. The same company have just completed three more Mallet compound engines which are much lighter than those for the Erie, one of which is shown in our illustration. These engines, which are for the Central Railway of Brazil, have a total weight in working order of 206,000 lbs. (The Erie engine weighed 409,000 lbs.), all of which weight is carried on the driving-wheels.

The cylinders are 17½ and 28 ins. by

compound is distributed between the four cylinders and two sets of crank pins, and the weights of the reciprocating and revolving parts are somewhat less than those of the ordinary freight engine of the present day. To illustrate this point a comparison of the weights of the reciprocating parts between this engine and a heavy consolidation engine is given.

Central Railway of Brazil.		Consolidation.
Main rod .....	Total 417 lbs.	825 lbs.
Front rod .....	" 208 "	183 "
Intermediate .....	" "	406 "
Back rod .....	" 95 "	330 "
Cross head .....	" 228 "	" "
High pressure piston .....	" 182 "	415 "
Low pressure piston .....	" 344 "	" "
Piston rod .....	" 115 "	230 "

As far as the distinctive features of the design are concerned, these engines differ very little from the Mallet articu-

weight of the engine alone, given by the builders as 204,000 lbs. The weight of the engine and tender is 304,300 lbs.

The boiler of this Brazilian is 64½ ins. at the smoke box end. It is of the straight top type with radial staying and carries a working pressure of 200 lbs. The fuel is Cardiff coal. There are 234 tubes 2 ins. outside diameter and 18 ft. long. These tubes give a heating surface of 2195.2 sq. ft. and with the fire box 121½ make a total of 2316.7 sq. ft. The grate area is 41 sq. ft., giving a ratio to heating surface as 1 is to 56½.

The tender is made with the usual structural steel frame, the sills consisting of 10-in. channels. The tank has a water bottom and carries in all 4500 U. S. gallons of water and 8½ tons of

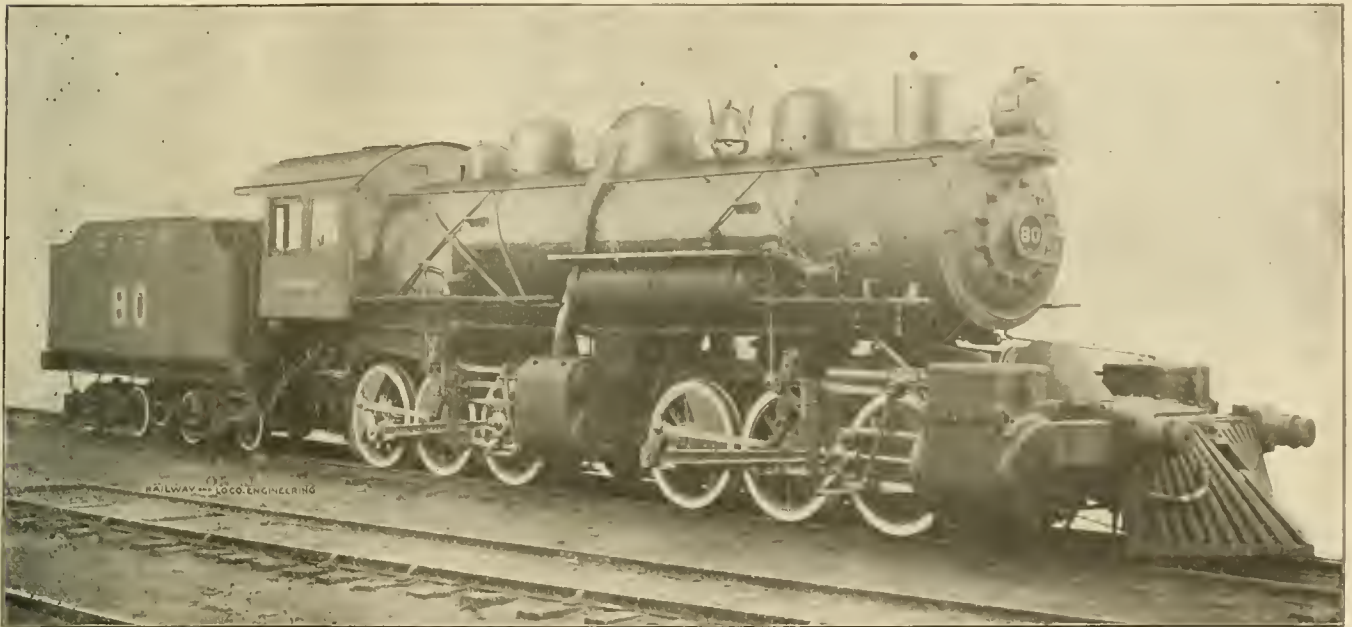

MALLET ARTICULATED COMPOUND FOR THE CENTRAL RAILWAY OF BRAZIL.

J. J. Da Silva Freier, Locomotive Supt.

American Loco. Company, Builders.

26 ins. stroke and they have a calculated tractive effort when working compound of 42,000 lbs. The driving wheels are 50 ins. in diameter and there are twelve of them, as the engine is built without engine truck wheels.

These engines are good examples of the advantages offered by this type for maximum power with minimum wheel load. The load is in this case 17,165 lbs. per wheel. It is an interesting fact that with 15 per cent. less weight than some consolidation engines built by the same company for the New York Central lines, with a total weight of 240,000 lbs., these Brazil engines have a greater maximum tractive power, when working simple, and when working compound their maximum tractive power is only 10 per cent. less than that of the consolidation engine to which we have referred.

The power developed by the Brazil

lated compound locomotive built by this same company for the Baltimore & Ohio Railroad. Owing to the lighter weight, however, a single articulated connection between the forward and rear frames has been employed instead of the upper and lower joint used on the B. & O. engine.

On account of the difficulty of placing the reversing shaft counter-balancing spring in the usual position for this design, two springs have been attached to the bottom of the reverse lever itself. With this arrangement each spring is lighter than that usually employed where a single counter-balance spring is used.

The wheel base of the engine is in all 27 ft. 8 ins., made up of what are practically two trucks each with a wheel base of 9 ft. The wheel base of the engine and tender together amounts to 55 ft. 2¼ ins. The light

coal. In writing us concerning this engine the American Locomotive Company say:

"It seems to us that a design such as is here illustrated, with a tractive power of 42,420 lbs., and a load per axle of only about 34,000 lbs., considering the light weight of the engine, and a rigid wheel base of only 9 ft. is an excellent one to meet conditions such as exist on South American roads, and in fact its adaptability is not confined alone to South America, but it would satisfactorily meet conditions existing on a great many of our own roads."

We append some of the principal dimensions of this engine for reference:

- Gauge of track, 5 ft. 3 ins.
- Driving Journals—Main, 7½ ins. by 9 ins.; tender journals, 5 ins. by 9 ins.
- Firebox—Type, wide; length, 90½ ins.; width, 65¼ ins.; thickness of crown, ¾ in.; tube, ½ in.; sides, ¾ in.; back, ¾ in.; water space, front, 5 ins.; sides, 4 ins.; back, 4 ins.

Brake—Pump, 9½ ins. L. H.; 2-reservoir, 18½ ins. by 102 ins.  
 Piston-rod diameter, 3 ins.; piston packing, C. I. rings.  
 Smoke Stack—Top above rail, 13.9½ ins.  
 Valves—Type, H. P. Piston, improved; L. P. Allen, Richardson; travel—H. P., 5 ins.; steam lap, ¾ ins.; travel, L. P., 5½ ins.; exhaust clearance, 3-16 ins.; valve gear, Walschaerts.  
 Setting—3-16 ins. constant lead.  
 Driving Wheels—Material, centres, cast steel; tender, 30 ins. diameter, rolled steel.

### Potent Pictorial Post Cards.

This little story, for the truth of which we can vouch, was related to us by a man who considered that a great service had been rendered to suffering humanity. It seems that there was an artist who had occasion to travel, not long ago, on one of our many trunk lines of railway. The artist was a pleasant fellow, but he believed in personal comfort with all his heart. When he got on the train he sought the smoking compartment of the parlor car, with the hope of enjoying himself.

He had an eye for color, and gazed out of the window on the russet foliage of the woods, the cobalt waters of the cool streams and at the fading glow of the amethyst sky, but he was not happy, for the seat he was in was not to his liking. There is no denying it, that although the seat had been designed with the idea of fitting the human anatomy with great exactness, it had failed of its purpose. The



DO YOU SEE THAT HUMP?

artist took a post card from his pocket and drew a sketch of himself, as he thought he looked, but certainly as he felt, while occupying that seat in the smoking compartment of the parlor car.

When the journey was over, he mailed the post card to a high official of the railway, whom he knew very well, and awaited developments. The high official was much amused at this novel form of protest and enclosed the card to an officer more immediately connected with the active management of the road. This officer was also amused at the card, and

realized the germ of truth which the representation of the cramped artist portrayed. He, however, at once detected the fact that the car with smoker seats as shown, belonged to another company, and with a good humored explanatory line, forwarded the card to the owning company.

The officer of the owning company who got the card, frankly acknowledged the home thrust and smiled at the artistic bit of railery upon the railway. He, however, gave orders that the seats which had thus been pictorially proved inimical to comfort should be taken out of the car when it next went to the shop for general repairs. The artist was in due time informed of this decision, but his attention was called to the fact that the railroad upon which he had traveled, was not responsible for the design of the furnishings in a car belonging to another company; though everybody deeply sympathized with him in his dire distress.

The artist thereupon gratefully acknowledged, by another post card, his reception of the welcome news. His attitude of mind being typified by the profound and respectful bow in which he showed regret for his mistake in having "post card-ily" reflected upon that railway for the shape of the seats which had not been designed by them. It is evident that at the same time a feeling of justifiable satisfaction extended to his very finger tips.

Thus it came to pass that a humorous post card in which a certain temper of mild irony had appeared, was destined to reach the deep seated cause of discomfort. The artist had clearly shown himself to be no stiff-necked objector, but one who had accommodated himself to circumstances, and had even bowed his shoulders temporarily to the yoke. He certainly felt constrained to hope that his attitude in the matter would be understood, and he has since had the satisfaction of knowing that it has been thoroughly appreciated. He confidently believes that he will be in good shape when he travels again.

### Engines as Fire Engines.

They fight fire with locomotives in the big yards of the Pennsylvania Railroad at Pittsburgh and Altoona. Fire pumps and hose are attached to switch engines used in "drilling" cars, and their crews are systematically trained as fire brigades to promptly put out any blaze that may occur among the hundreds of cars out of reach of city fire departments. The yards are divided into districts, numbered as are fire alarm boxes in cities. When a fire is discovered, the nearest switch tower is notified and alarm whistles are blown throughout the yard limits. By a code of signals, engineers of locomotives within the yard can tell from the whistles just

where the fire is, and signals are at once set indicating the routes by which to reach the fire, and by the time the engines arrive, the crews have pumps ready to work and hose ready to un-reel. In the fire organization the assistant yard master acts as chief, and gives general directions both in fire fighting and in drills. The conductor of each train crew acts as foreman of that crew;



BEG PARDON, I THOUGHT YOU HAD DESIGNED THAT SEAT.

the flagman looks after unreeling and connection of the hose; the two brakemen act as nozzle-men and direct the stream.

### Thin Gold.

We watched a painter spreading gold leaf on the lettering of a car and remarked that he was spreading out with lavish hand the elements of the world's favorite currency. He turned about and said:

A twenty-dollar gold piece covers much surface when it is used as gold leaf. Few people realize how thin gold can be spread. In the manufacture of gilt wire used for embroidery the amount of gold employed to cover a foot of wire does not exceed the 720,000th part of an ounce. Those fond of figuring know that if the 720,000th part of an ounce is used in covering 1 foot of wire that in an inch there is only the 8,640,000th part of an ounce. We may divide this into 100 parts and yet see the gold quite distinctly with the naked eye, and find that 864,000,000th part of an ounce of gold is visible, and the exceedingly minute particle possesses all the characteristics of a large piece.

A sound discretion is not so much indicated by never making a mistake as by never repeating it.—*Bovee*.



# General Correspondence

## Eight-Hour Procession in Australia. Editor:

The display as seen from the photo consists firstly, of one of three new and beautiful banners of the new South Wales Locomotive, Engine Drivers, Firemen, and Cleaners' Association, drawn on a lorry by two horses decorated. This banner is identical in design with the other two, one being allotted to each of the three districts, Northern, Western and Southern, respectively.

Secondly, of three small models drawn on a lorry by two horses decorated. These small models represent, 1st, the first successful locomotive, "the Rocket"; 2nd, the first locomotive run in New South Wales in 1855; 3rd, the present heavy goods engine in use in New South Wales, "the Consolidation T. Clase engine," over which there were placards or signs showing their respective weights and tractive power. These three models were built to the scale of 1 in. to the foot by a member of this association.

Thirdly, the large model of a suburban tank engine, drawn by six horses decorated. The length of this model over buffers is 24 ft. 4 ins.; height from base of wheel to top of chimney 10 ft. 4 ins.; width 6 ft. 6 ins.; diameter of boiler 3 ft. 9 ins.; diameter of leading bogie wheels and back radial wheels 28 ins.; and driving and trailing wheels 48 ins. Driving and trailing wheels are coupled,

the whistle throughout the journey, maintaining a steam pressure of about 75 lbs. A small injector was used to feed water into the boiler, kerosene tins being used to carry water in, and stove piping served

ner; one postillion representing the age 1855, when the first locomotive ran in New South Wales, rode with the pair of horses hauling the three small models; and three postillions representing the



THREE STAGES IN LOCOMOTIVE DEVELOPMENT. POSTILLION DRESSED IN THE COSTUME OF 1825.

to carry smoke, raised with tarred rope, from the grate, through the boiler barrel of model, and up the chimney. This model was painted mainly of green and was built solely by members of this association.

present age rode with the three pairs of horses hauling the large model, in the same order as you see them in the plate. Smoke was emitted from the chimney of the large model throughout the journey and the whistle was sounded continu-



VIEW OF THE EIGHT-HOUR CELEBRATION PARADE, SYDNEY, AUSTRALIA.

the length of rod being 7 ft. between centres. The bogie and radial wheels are of steel, the driving and trailing wheels of wood, and the estimated gross weight of model 25 cwt. A small grate was fixed in the fire box to burn coal and shale fuel, a small air reservoir was used as a boiler to generate steam to sound

All the horses used were black, a very fine team of ten blacks, dressed with blue and white dressings, and five postillions, dressed representing the three respective ages of locomotion, rode on the horses one for each pair thus: One postillion representing the age of the Rocket rode with the pair of horses hauling the ban-

ally. A large number of our members marched in the procession, led by the Professional Musicians No. 2 Band, and according to the opinion of spectators very freely expressed throughout, it was the best display in the procession, of which some fifty-five trades' unions took part. However, when the decision was

made known as to who were the prize winners, it was found that we were awarded only second prize, which no doubt was to some extent due to the fact that we received first prize the previous year; nevertheless, there were other very excellent exhibits.

J. A. HILAIRE,  
Sec. Sydney Branch.  
*Sydney, N. S. W., Australia.*

### Good Things on the St. Paul Road.

Editor:

While on a trip to Madison, Wisconsin, recently I paid a visit to the round house of the Chicago, Milwaukee & St. Paul Railroad in that city, and noticed

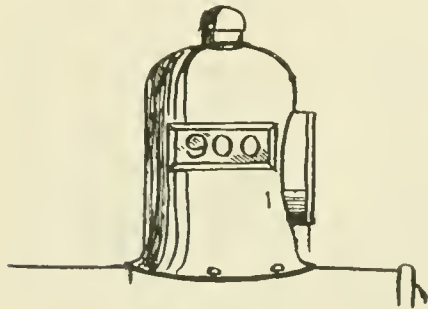

FIG. 1. DOME SHAPED HEADLIGHT.

several interesting things in and around the house and yards.

They have a twenty-three stall brick round house there, and the engines face towards the turn table, which isn't often seen now. The house had good doors across each track with large sized glass windows in them; which makes the house warm and light in cold weather, of which they have plenty.

The St. Paul seems to be the home of the Baldwin compound, the original Vaucrain type I mean, and fully one-half of all the engines I saw were equipped with this form of cylinders. On many engines they have taken the original jackets off the cylinders and substituted ones that are flat from the top of the high to the bottom of the low pressure cylinders. This gives the locomotives a somewhat peculiar look, as if they had some new form of piston valve.

The fast express trains between Chicago and Madison are hauled by a type of locomotive not often seen now, "Atlantic" types with narrow fire boxes between the trailing wheels, and Vaucrain compound cylinders. The engines are rather unusual looking, as they appear very short for this type of machine. They seem to do their work in fine style, and are well kept up.

Several of the St. Paul engines have a curious design of headlight, shown in Fig. 1. It is cylindrical in shape with a round top and is bolted by a flange to the top of the smoke box. It is a neat design, but strikes the average engineer as decidedly novel.

I noticed a handy little crane in the round house like the sketch, Fig. 2, for removing cylinder heads from compound engines. It fitted right into the flag socket on the end of the bumper timber and was attached to the cylinder head by means of an eye passing over the bolt in the middle of the head. The crane can easily be made without much outlay and saves lots of work.

Another neat scheme was an air cylinder for working cylinder-cocks. I saw it attached to a small 8 wheeler, but it could be applied to any locomotive. A small cylinder is bolted to the bottom of the engine cylinder and works the cocks by direct connection with the air piston. A pipe leads to the cab where a cock regulates the admission of air. When the air is exhausted a spring forces the cocks shut. This little attachment is shown in Fig. 3, and saves lots of levers and rigging that are always getting out of order. The St. Paul owns its parlor cars, and I never saw finer ones

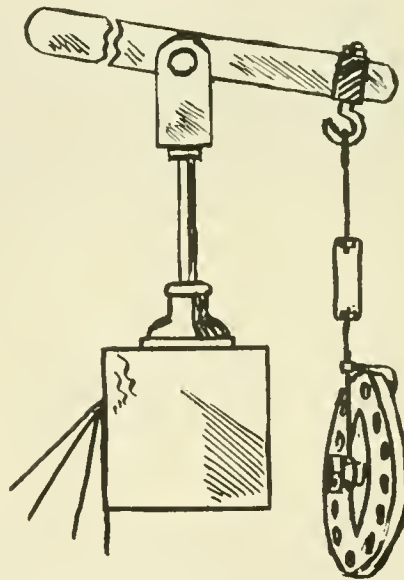

FIG. 2. FLAG SOCKET CRANE.

anywhere. They are painted the color of the road, a dark orange, and look very handsome.

Though Madison is not really on the main line a very good passenger service is maintained, and I got a very fair idea of the equipment of the road. I returned well pleased with my visit.

HUGH G. BOUTELL.

*Urbana, Ill.*

### Shaw Balanced Engine.

Editor:

I saw in your October number a cut and description of my old locomotive. You say the locomotive was substantially the same as Haswell's Duplex, except that the cylinders were arranged side by side, which is not so. First, the Haswell's cylinders are on a single axis relates to a

straight line, therefore they do not come on to the dead center at the same time and are not in balance as was the Shaw. Again, the Duplex has four valves, one for each cylinder, whereas the Shaw engine has but one valve for the two cylinders, avoiding two sets of valve gear, and making it much more simple. Also you say the driving wheels were 63 ins. in diameter, whereas they are 69 ins. in diameter. I call your attention to these points of difference so that you may give me credit for what I did invent, and not be classed with freaks or curiosities, as the old Shaw was practical, as is shown by the engines of to-day, working two cylinders in opposite directions, worked with one valve for two cylinders, I being the first to do it in this or any other country.

One word in relation to this problem of balancing that seems to have been overlooked by writers upon this subject, viz., the efficiency of the locomotive. It is a well known fact that the transmission of power is through frictional contact with the rail and the work done depends upon the amount of contact. The question is not so much the size of the boiler or cylinders as how much of this power can be transmitted through this frictional contact to the work done. Let us look at our present locomotive with its counter-weights in the driving-wheels, one moment striking a blow of 25 tons, the next lifting the engine from the rails and breaking the point of contact, the very thing we depend upon to do the work. On the other hand, take the balanced engine without counter-weights, no blow, no lift, but a constant adhesion to the rail, utilizing all the power it is possible with frictional contact. There is no doubt that an engine well balanced will do the same amount of work that an unbalanced one will that is 15 tons heavier. In other words, build a 100-ton engine to do the work of an 80-ton well balanced engine. Good engineering indeed!

HENRY F. SHAW.

*West Roxbury, Mass.*

[We print our correspondent's letter as a further contribution to the subject. The points he brings out are interesting. We

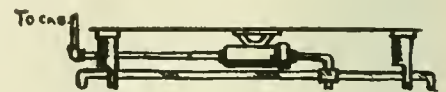

FIG. 3. AIR DEVICE FOR CYLINDER COCKS.

must, however, call his attention to the fact that his work is not classed by us as a freak. On page 473 of the October paper we spoke of the chapter on Curiosities of Locomotive Design in Mr. Angus Sinclair's book on the "Development of the Locomotive Engine." In that paragraph we said: "Some of these engines were freaks pure and simple, while others

were honest endeavors to realize more or less satisfactory forms of construction, which, however, the test of time did not permit to survive." Mr. Shaw's engine was certainly one of the latter class.—Ed.]

#### Permanent Way in England.

Editor:

In a recent trip through the British Isles I observed that nearly all English railways are double tracked and their excellent condition reflects great credit on the industry and care of the maintenance of way departments. All the roads are well ballasted with rock, and are free from grass and weeds. This "well-kept" state of af-

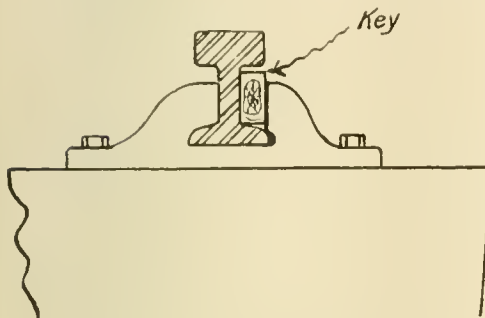

FIG. 1. SECTIONAL VIEW OF RAIL.

fairs applies to branch lines as well as to main lines. The London & North-Western Railway owns as beautiful a stretch of double and quadruple track line as any railroad in the world. The stone ballast on this line is crushed somewhat smaller than the ballast on the other lines and is about one half the size of the rock ordinarily used on American railways. The ties are buried in the bed of stone until only the top surface shows. The ballast extends out on each side of the track to a distance of some six or eight inches beyond the end of the tie and slopes off to the main road bed.

The standard rail is 90 lbs. to the yard and, contrary to the practice in America, it is not spiked to the tie, but rests in an iron chair which is bolted to the tie as shown in the accompanying diagram. The inner side of the rail, as shown in Fig. 1, rests against the metal back of the chair. The outer side of the rail rests against a wooden key which is driven between the rail and the chair as shown in the diagram. The rail is slipped down between the front and back of the chair and then the key is wedged in with a hammer and the rail is thus made secure. The bases of the rails are not as wide as American rail bases and are usually somewhat rounded at the edges.

The cuts and fills along English railways are sodded and in many places rows of small trees and

shrubs are set out for the purpose of holding the bank in place as well as to serve as ornaments. Unsodded cuts are few in number. All the telegraph poles are braced by at least two wires which are supplied with turn buckles in order to make the wires taut or slack as needed. At curves where there is some extra strain on the poles four braces are used instead of two. Nearly all of the poles are supplied with a roof shaped metallic covering on top as a protection against the elements.

The railroad tracks never cross the highways but either go over them by bridge or under them. No one is permitted to walk on the track except employees of the railway company. Elevated foot bridges or subways are provided at stations for the convenience of passengers who desire to cross from one side of the track to the other. All of the station platforms are elevated some three feet above the rails, which feature enables a passenger to walk directly into his compartment without the necessity of climbing a number of steps.

The locomotives are painted from wheels to boiler-top in a color selected as the standard of the particular road to which they belong. Thus the engines of the London and North-Western Railway are painted a very dark green, almost black, and are trimmed in red; those of the Caledonian are painted blue with red frames and buffer beam; the Glasgow and South-Western are of a grass green color; the North British are a light brown with slight red trimming; the Midland engines are a Pennsylvania Railroad red. Their express engines have been somewhat fancifully called the "Red Racers of the Midland," and the engines of the Great Northern; London and South-Western; London and South-Eastern are a light green. The tenders are painted to match the locomotives while the cars are mostly confined to white, orange, yellow and various shades of red. Some of the engines on the London, Brighton and South Coast have an extra frill, consisting of a brass covered dome and brass capped smoke stack.

English railway tickets usually have the price of same stamped upon the face. There are no yard-long tickets. If the journey requires a number of changes the ticket for such is in book form and a leaf is torn out at each stage along the route.

English railway trains make good time. Even local trains run at high speeds over some sections of their routes. The proportion of freight trains to passenger trains is small in

comparison to the same proportion in this country and consequently the average speed of the train is considerably higher. The English fast trains do not exceed the speed of American fast trains but the proportion of fast trains is greater.

Nashville, Tenn.

E. C. LANDIS.

#### Piston Versus Slide Valves.

Editor:

The history of piston valves would make a large book and the claims that have been made for them at different times by their over-zealous advocates would make a very much larger one. The piston valve can be readily divided in three classes, namely, the solid (or plug) valve, the semi-plug, and the valve with packing rings that is supposed to be held against the bushings by the aid of steam pressure. The plug was made so as to fit its bushing in such a manner as not to allow much steam to pass by the valve into the exhaust ports, and if it was not for the fact of the valve wearing smaller (by use) and the bushing larger, it would be the ideal piston valve, but up to date the above has not been accomplished. The semi-plug valve was so named because it was only one-half as good as the plug valve. It was made with rings that were supposed to have intelligence enough in themselves to go up against the bushing when steam was admitted and be held in that position by the pressure of steam against the side of the rings preventing them from exerting any undue pressure from the steam against the bushing, allow-

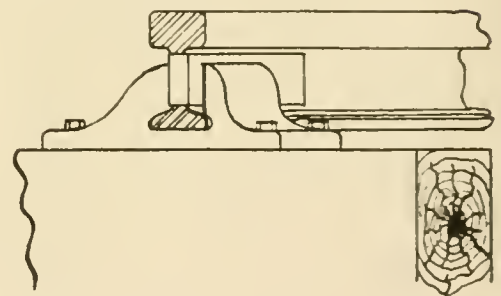

FIG. 2. PERSPECTIVE VIEW OF RAIL AND CHAIR.

ing it to act as a solid plug valve. The trouble has been in not finding any metal for the rings that has shown enough intelligence to carry out this idea. If there is any one that knows where such metal can be found it might be well for them to let those interested in the semi-plug valve know of it at an early date. The piston valve with the Ramsbottom packing rings held in place by the steam pressure, and moving over the port openings in the bushings, are so ridiculous a proposition that it would be hard for anyone of a mechanical turn of mind to ever expect them to remain tight for any length of time, and the reason is so obvious it

is not worth while to say anything of them. Another reason why the piston valve is wasteful is on account of the clearance between the piston in cylinder and the valve, and this is aggravated by the use of relief valves having long channel ways to fill before reaching these valves.

The flat slide valve has always shown better economy in repairs and fuel than the piston valve, and it is hard to understand why anyone will use the piston valve when the other is better. The very best valve known for locomotive use today is the flat slide, and all know that is poor enough.

A. SCHEUMACHER.

Scranton, Pa.

**Metal Marker Flags.**

Editor:

I herewith send you a sketch of a metallic marker to be used on locomotives, which if you find desirable I should be glad to have you publish in RAILWAY AND LOCOMOTIVE ENGINEERING.

This arrangement consists of a metallic box containing two standards or shafts pivoted at the edge of the box on which is fastened a moveable piece of sheet iron painted in accordance with the colors prescribed for

in place. This metallic "flag" is moveable on the shaft so when the engine is backing the flag is able to properly adjust itself.

W. W. UPDEGRAFF.

Fruitvale, Cal.

**Different Kinds of Education.**

Editor:

The question is often asked, what is the difference between a self-educated man and a college-trained man as a factor in the mechanical world. From the view-point of one who has had a good opportunity to see both sides of the question, it is plain that college training fits a man for reasoning from cause to effect, and the ability to thus reason is the one advantage the technically trained man has over one who has acquired an education by home study—that is, the self-trained man.

The college man recognizes the value to himself of a well grounded knowledge of shop practice and does obtain as much of it as is possible in his alma mater, but it is a fact that he strongly objects to use the time necessary to get a proper insight in actual shop practice, preferring to step at once into an office. This, it is plain, makes him a good office man, while it leaves him at the mercy of the man who has been

as well as from the side of design. Self-educated men are not as scarce a quantity as they were a few years ago, but are still so few as not to be recognized as the power they really are. The reason for this is that the old idea that there was only one way to acquire an education is still kept alive by those interested in holding the official places open for the college man.

In general it may be said that when everything is equal from both the practical and theoretical standpoints, the college-trained man is the most valuable factor in the mechanical field. When, however, the college man fails to fit himself for the problems of shop practice by an intimate study of their theories—not by manual skill with a hammer and file—he is not the equal of the self-educated mechanic who in addition to his shop knowledge has learned to think, and knows how to apply his theories to his practice. Much has been said about the superiority of the technically educated man as an executive officer, but those who have been brought up in shop work know that the manner in which a man has received his education has no connection whatever with that subtle personal characteristic of knowing how to handle men. To the mind of the writer, executive ability is acquired just the same as any other accomplishment.

DEVELOPMENT.

Scranton, Pa.

**Piston Rings Scientifically Turned.**

Editor:

Reading in the November issue of the RAILWAY AND LOCOMOTIVE ENGINEERING the story of the piston ring, sets us thinking of the good old days some thirty or more years ago when we were learning the machinist trade—in a sort of a way—in the shops of one of the great coal roads of Pennsylvania, where fuel was cheap as dirt, and where the management of the shop was of the free and easy sort. Thus when it came to putting the pistons into the finished engine in the shop or roundhouse we placed the ring on the rail and chopped out a section of about one inch and a quarter and tried the ring into place in the cylinder. If it went, all right. If not, we put it on the rail again, lopped off half an inch more, and without any filing or fancy work we shoved it into place against the bull ring and let it go at that. So far as we apprentices knew that was the end of the matter; but in the light of subsequent experience, however, we may conjecture what followed.

Everyone, of course, who knows anything about a piston knows that the piston rings at the outset bear hard at the points, and that for half a foot or so away from the points, around the circumference of the cylinder, the rings

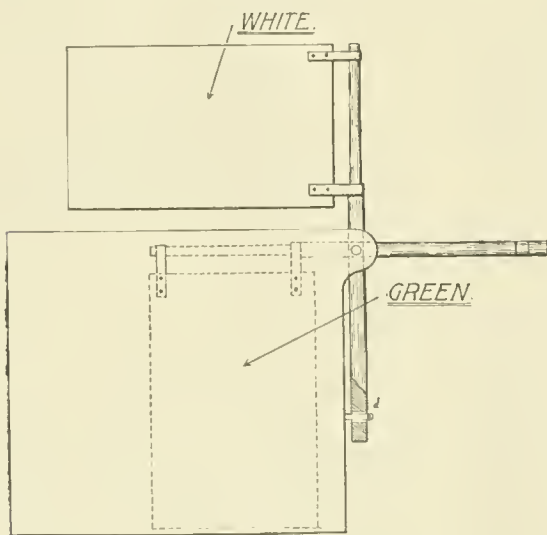
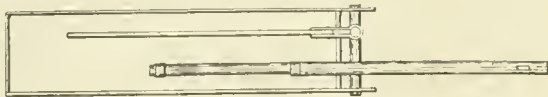

METAL MARKER FLAGS.

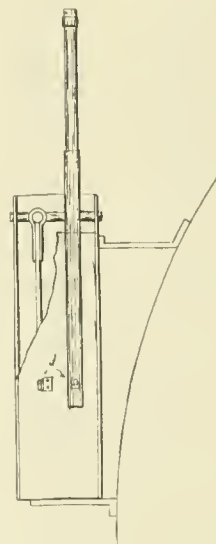

markers in the code. When the markers are not in use they are dropped down into the box c, over which a slide is placed from the rear. This keeps out cinders and helps to keep the paint clean. When a marker has to be displayed, the staff is brought to a vertical position, and a pin is placed in the hole of the tongue d, which holds it

able to have a good shop training and at the same time become familiar with the principles of engineering as laid down in text books on kinematics, physics, and mechanics of materials. Such a man is the better one for the manufacturer in any capacity since he is at home in all details of shop production from the practical side of it,

spring away from the cylinder bore in their act of assuming the ovoid form consequent upon a gap being at one point of the ring, and the compression caused by forcing the ring into a cylinder smaller in diameter than the ring itself.

When this defect is noted it is the usual practice to do one or all of three things, namely: To bend the points of the ring inward by pening upon the outside; by bending the ring by blows of a hammer upon the inside after placing the ring in a "V" block; or by filing down the projecting points of the ring. The objections to these remedies are: In the first instance the hammer marks deface the rings and there is danger of breaking the ring, and there are few mechanics who understand the art of pening; and even when this act succeeds the ring is likely to resume its former shape, as the "pened" portion wears away. In the second instance there is always the danger of breaking even the best of cast iron; and in the third case we are robbing the ring, which of itself is sufficient to condemn such a cure—even if there was always a man on the job who understood his business.

In view of these, the natural propensities of rings to go wrong when made in the usual way, we are led to the conclusion that the true and only way to insure a proper fit of a ring into a cylinder is to turn and bore the ring while the stress or strain under which it works in the cylinder are active upon it. To this end we must therefore in making the ring allow a trifle on the inner and outer di-

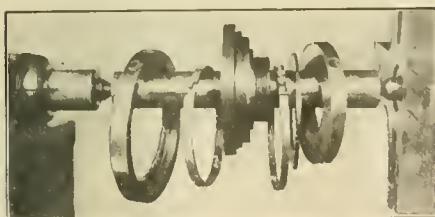

MANDREL, RINGS AND PARTS.

ameter to be dressed off in the final act of finishing.

The special tool requisite for this purpose is shown in the view that accompanies these remarks and is simply a mandrel on to which the ring—after being cut—may be compressed by the aid of a thin, flexible band; and so held until the large nut grips it latterly, when the band may be removed, after which the ring may be turned off to the exact size of the cylinder bore. The band being thin and pliable, the ring is free to assume such a shape as the laws of force would direct. The ring having now been turned to the size of cylinder, the next act is to spring the ring into the shallow cylinder at the other end of the mandrel, grip it laterally as before with a large nut or clamps, and bore it to the desired diameter.

The mandrel shown in the cut was designed to finish rings for a C. P. 14 air compressor. The cylinder bore being  $5 \frac{7}{16}$  ins., the rings are first turned to  $5 \frac{5}{8}$  ins. diameter, and bored to  $5 \frac{1}{4}$

ins. inside. They are then sawed through and lapped at the ends, this act being done in the shaper or milling machine with the aid of a jig. The rings are then closed on to the mandrel  $4 \frac{31}{32}$  ins. and turned off to  $5 \frac{7}{16}$  ins., then sprung

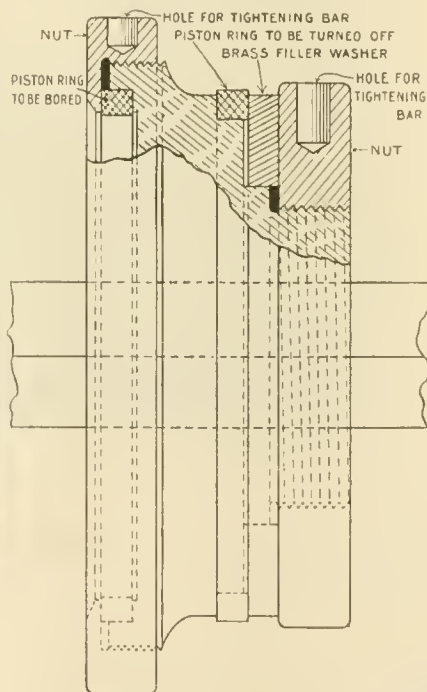

SECTION OF PISTON RING MANDREL.

into the shallow cylinder end of the same mandrel and bored to 5 ins., the diameter of the piston at the bottom of the groove.

W. L. CALVER.

New York.

**Do You Want to Be Happy?**

Don't worry; eat three square meals a day; say your prayers; be courteous to your creditors; exercise; go slow and go easy. Maybe there are other things you need to make you happy, but these, I reckon, will give you a good lift.—Abraham Lincoln.

**Curiosities of Locomotive Design.\***

AN EARLY DOUBLE ENDER.

The oddity shown in Fig. 24 was one of several locomotives built in 1862 by the Northern Railway of France. The

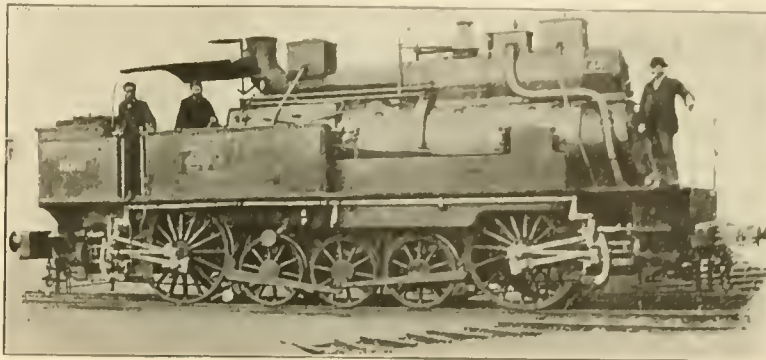

FIG. 24. A FRENCH EXPERIMENT IN 1862.

best that can be said of this locomotive was a remark made on a ridiculous freak designed in the office of *Locomotive Engineering*, and called the *Gilderfluke*, as a take-off on idiotic designs of locomotives getting forced into notice. This engineer remarked, "the thing would move." As may be noted, this was one of the early double end locomotives.

LA PARISIENNE.

A remarkable freak that was to be seen in Paris in 1900 bore the above name. It had three pairs of driving wheels, 7 ft. diameter, coupled, and two pairs of wheels of the same size carried the tender. Its curious appearance was the only thing that made the *Parisienne* worthy of passing notice.

JOHNSTONE'S DOUBLE-ENDED COMPOUND.

A famous engineer once remarked to an inventor, who had presented an extraordinary complicated arrangement of mechanism as an improved valve motion, "You are suffering from abnormal inventive fertility." An engineer gifted with the inventive faculty is in danger of pushing his inventive fertility to a rank crop that is expensive to harvest. I have always thought it was some such inventing force that pushed F. W. Johnstone, mechanical superintendent of the Mexican Central Railway, to design the locomotive shown in Fig. 25, which was one of three built in 1892.

The engine, as will be readily understood, was a most extraordinary form of a locomotive. It looks like two Mogul-2-6-0-locomotives fastened cab to cab; but it is structurally a good deal more than that. The reputed purpose of this odd type of engine was to provide an extraordinarily powerful flexible motor for climbing the steep mountain grades of the Mexican Central Railway, the flexibility being sufficient to go round very sharp curves with the least possible fric-

\*From "Development of the Locomotive Engine," by Angus Sinclair.

tional resistance. The flexibility was obtained by securing the driving wheels in a truck, which was free to move in a line

cular cylinders, the high pressure cylinder being in the center and the low pressure cylinder forming the outside concentric ring.

The high pressure cylinder was 13 ins. diameter, and the low pressure 28 ins. The stroke was 24 ins. It was calculated that each pair of cylinders would develop power equal to a 19x24 in. simple engine.

That cylinder arrangement violated the principles relating to the conservation of heat, for the comparatively cold, low pressure steam encircling the high pres-

company, for the contractor of a narrow gauge coal road near Pittsburgh named Bausman. The workmen called it "Bausman's Rhinoceros."

The curious thing about the engine was that it had no main or side rods, the piston rods extending out on both ends of the cylinders and connected to slotted cross heads, fitted with sliding blocks, in which the crank pins worked. The valve gear was of the Carmichael type, illustrated in the chapter on Valve Motion.

#### THE OLDEST CURIOSITY.

During the Diamond Jubilee of the late Queen Victoria, when all London was decorated with flags, streamers and emblems, the headquarters of one of the well known cricket clubs in that city had among their decorations the words, "Well played; 60, not out." The old engine which we illustrate in Fig. 27 is still at work, and the North Eastern Railway of England might

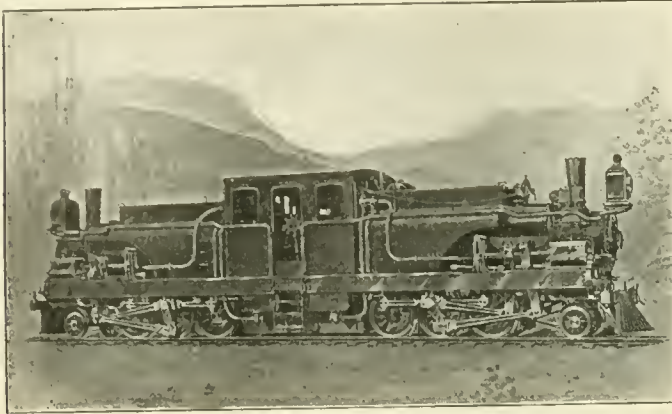

FIG. 25. JOHNSTONE'S DOUBLE-END COMPOUNDS.

different from that followed by the main frames. In the Mason bogie engines, the driving wheels were grouped in a flexible truck which carried the cylinders. In the Johnstone engine, the cylinders and boiler were carried on the main frames, separate from the driving wheel truck.

As the cylinders were not in line with the driving wheels in passing curves, it was necessary that a special method of transmitting the power from the cylinders should be employed. This was done in a very ingenious way through levers that transmitted the power and at the same time compensated for the varying distances between pistons and crank, due to the swivelling of the driving wheels. Without the compensating arrangement it would have been necessary to give the engine so much cylinder clearance that the loss of steam would have been very great. The power transmitting levers are seen in the back of the cylinders, connected at the top by a short link and the bottom ends pinned to the front end of the main rods. There were two of the latter, one connecting with a crank pin, the other with a return crank. The piston transmitted motion to the back one of the two levers, and that gave motion

sure cylinder would be certain to exert condensing effects upon the steam in the high pressure cylinder. Even in the hands of their friends it was difficult to keep



FIG. 27. OLDEST LOCOMOTIVE IN THE WORLD, DAILY UNDER STEAM.

the engines at work, and after a few years of unsatisfactory service they were changed to accepted forms.

well say of it, as the cricketers did of the Queen, "Well played; 84, not out."

We are indebted to Mr. Wilson Worsdell, chief mechanical engineer of the North Eastern of England, for the photograph, diagrams and information concerning this remarkable engine. Mr. Worsdell is of the opinion that it is the oldest locomotive in the world that is daily under steam, for it was built in 1822 and is now regularly used as part of the motive power equipment in the collieries of Sir Lindsay Wood, who is one of the directors of the North Eastern Railway. The collieries are situated in the county of Durham, at a place called Hetton-le-Hole, in England.

The engine has vertical cylinders 10¼ inches in diameter and 24 inch stroke, with cross arms instead of cross heads working in upright guides which are braced diagonally from the

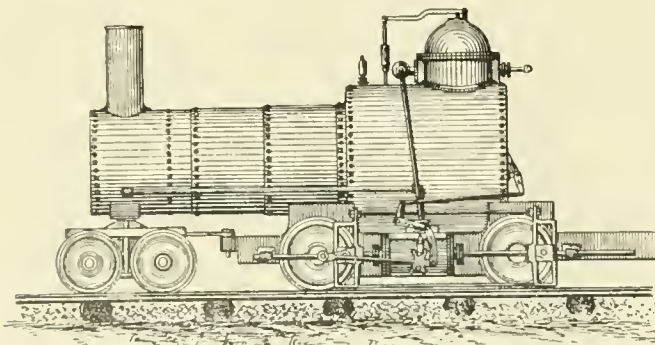

FIG. 26. PITTSBURGH SLOTTED CROSSHEAD LOCOMOTIVE.

to the front lever, which was fulcrumed securely to the frame near its center.

The engines were compound, with an-

first product of the Pittsburgh Locomotive Works, and was built by Thatcher Perkins, engineer and superintendent of the

#### AN ORIGINAL FORM OF CONTRACTOR'S LOCOMOTIVE.

Among the minor sacrifices that were called locomotives was that shown in Fig. 26. This was the

top of one to the bottom of the other. The cylinders rest directly on the shell of the boiler, which is not covered with any lagging. There is a small cab on one side, in which the "driver" is evidently allowed to sit down. The half-tone illustration shows him with his hand on the brake apparatus. This is

tion was conveyed through a link, as shown at B. This arrangement is more clearly shown in Fig. 29. The reversing lever was so fixed so as to shift the link block in the link. The half-tone illustration exhibits this arrangement also, but the adjacent ends of the links and the bottom of the re-

been done successfully and Dewey Bros., Goldsboro, N. C., are making such locomotives for logging railroads, one of them being shown in Fig. 30. As will be observed, the piston rods are coupled direct to the crank pin. The engine is reversed by means of a four-way cock which changes the steam pipe into an exhaust pipe and vice versa. The cylinders oscillate on a trunnion which passes through the middle casting. This trunnion passes through a coil spring which pulls the cylinder up against the saddle, allowing it to oscillate and yet make a tight joint. No valve gear is necessary. Fig. 31 is a line engraving of Grew's Ice Locomotive for Russia built in 1861.

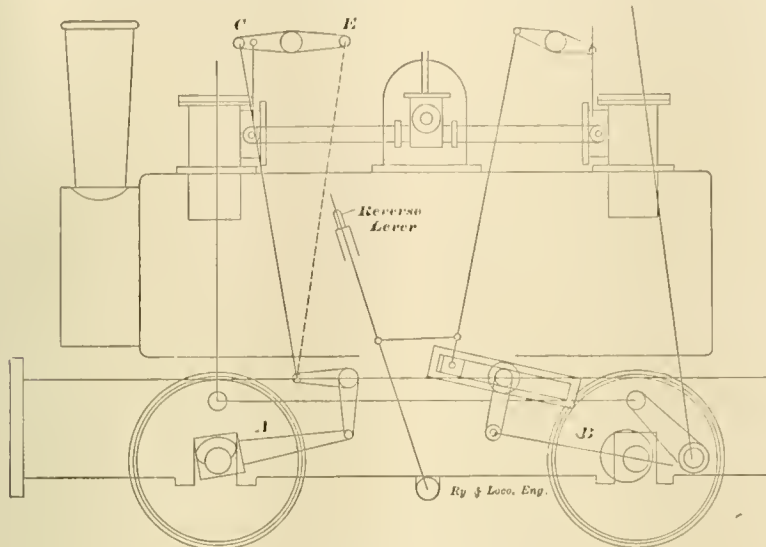

FIG. 28. ORIGINAL VALVE MOTION.

a form used a good deal in the British Isles, and is an upright shaft placed in a hollow stand. The shaft has a screw thread cut on the lower end, upon which a nut works. The nut has two trunnions on either side, which take the place of a pin in a lever. The nut can be run up or down the shaft, according to the way the handle is turned, and the nut, although moving the end of a lever, always remains parallel to itself.

The familiar "life guards" are to be seen in front of the leading wheels. These are the vertical metal bars which reach from the buffer beam to very nearly the rail level. They are used throughout the British Isles and on the continent at the present day. The sand box is seen comfortably nestling against the side of the smoke box on the running board level.

The line engraving, Fig. 28, shows the valve gear at A as it was originally built. The motion which actuated the valve was obtained from a cam working in a square box. This motion was conveyed through connecting links and rods to a lever fixed above the steam chest. The valve worked in a box on the side of the cylinder. The reverse motion was obtained by the driver withdrawing bolt C and moving the rod to the other end of lever and replacing the bolt at point marked E. This had to be done separately for each of the cylinders. About the year 1880 the old arrangement was altered. An eccentric sheave was fixed on the axle instead of the cam, and the mo-

verse lever and its fulcrum are hidden behind a metal plate.

According to our modern rule, the engine has a calculated tractive effort of about 4,700 pounds.

OSCILLATING CYLINDER LOCOMOTIVES.

Oscillating cylinders were in great repute for steam engines for a few years, especially for marine power, and

Installing Block Signals.

According to information compiled in the office of the chief engineer of the Union Pacific, that road has now in operation and equipped with electric automatic signals, 469 miles of single track and 244 miles of double track. An additional 176 miles of double track and 197 miles of single track installation is under construction and will soon be in service. More than 300 distant switch signals, protecting the movement of trains toward 158 stations and spurs on the main line of the Kansas and Colorado divisions, have also been put in place. When all the work now authorized and under construction is completed, the entire main line of the Union Pacific from Council Bluffs, Iowa, to Green River, Wyoming, will be pro-

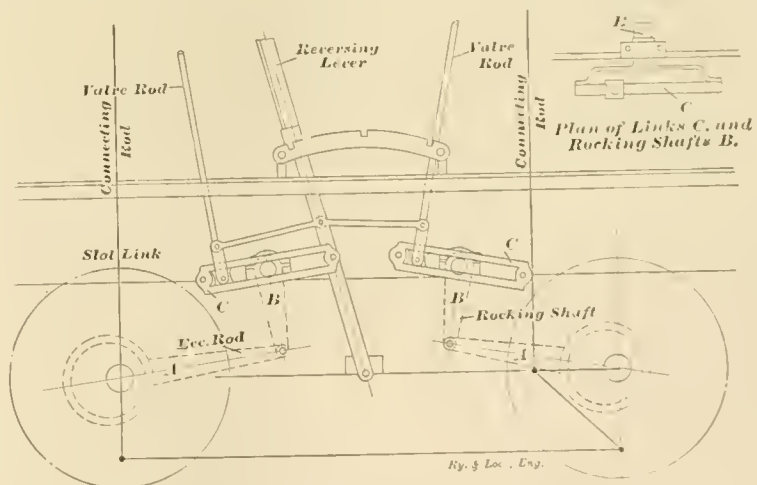

FIG. 29. MODERNIZED VALVE MOTION.

claims were persistently made that an oscillating engine would transmit more power to the crank pin than any other. Those favoring that kind of engine held that it had no dead center to speak of and that the leverage was correspondingly great.

A locomotive might not be regarded as a good subject for the application of oscillating cylinders, yet that has

tected by automatic signals. The main line of the Kansas Division, from Kansas City to Topeka, is already equipped with automatic block signals. Practically all this work has been done since the beginning of 1904.

Undertake not what you cannot perform, but be careful to keep your promise.—George Washington.

# Railway and Locomotive Engineering

A Practical Journal of Railway Motive Power and Rolling Stock.

Published Monthly by

**ANGUS SINCLAIR CO.**

136 Liberty Street, New York.

Telephone, 984 Cortlandt.

Cable Address, "Loceng," N. Y.  
Glasgow, "Locauto."

**Business Department:**

**ANGUS SINCLAIR, President.**  
**JAMES KENNEDY, Vice-President.**  
**JAMES R. PATERSON, Sec'y and Treas.**

**Editorial Department:**

**ANGUS SINCLAIR, Editor.**  
**GEO. S. HODGINS, } Associate Editors.**  
**JAMES KENNEDY, }**

**Advertising Department:**

Eastern Representative, **S. I. CARPENTER, 170**  
**Summer St., Boston, Mass.**

**British Representative:**

**THE LOCOMOTIVE PUBLISHING CO., Ltd.,**  
**Amen Corner, Pasternoster Row, London, E. C.**

**Glasgow Representative:**

**A. F. SINCLAIR, 15 Manor Road, Bellahouston,**  
**Glasgow.**

**SUBSCRIPTION PRICE.**

\$2.00 per year, \$1.00 for six months, postage paid in the United States, Canada and Mexico. For other parts of the world, \$2.50, or ten shillings. Single copies, 20 cents. Remit by Express Money Order, Draft, Post Office Order or Registered Letter.

Mailing address can be changed as often as necessary—always give old and new address, and if you subscribe in a club, state who got it up. Please give prompt notice when your paper fails to reach you properly.

Entered at the Post Office, New York, as Second-class mail matter.

Copyright by Angus Sinclair Co., 1907.

For Sale by Newsdealers Everywhere.

## Conciliation.

The railway dispute in England which threatened to produce one of the most serious strikes of modern times, has happily been settled by concessions on both sides and a recognition of the principle of arbitration. The disagreement arose out of the refusal of the railway companies to recognize the corporate union of the employees, and the very natural assertion by the men of their rights to be so recognized.

As the case stands now, a number of the leading companies and the representatives of the Amalgamated Society of Railway Servants have signed the agreement, proposed by Mr. David Lloyd-George, president of the Board of Trade, providing for the consideration of disputes by a board of conciliation, composed equally of directors of the companies and employees, with an appeal to arbitration if the trouble cannot be settled by the board. The agreement is terminable by a year's notice at the end of six years.

The settlement is regarded as establishing Mr. Lloyd-George's reputation for

tact and diplomacy. The companies claim that they have not yielded to the demands for recognition of the union, and perhaps technically they have not, but nevertheless they have bound themselves to compulsory outside intervention in disputes with their employees. Both sides profess satisfaction with the result.

The fight for the recognition of the union of employees has in times past been fought out very bitterly in this country, but the admission of the principle has eventually not been regretted even by those who at one time most vigorously opposed it. The Brotherhood of Locomotive Engineers and the Brotherhood of Locomotive Firemen and Enginemen are now regarded as allies of the railroad officers in the maintenance of discipline and for all that goes to make up good internal government in our railway systems.

Recognition of a union places responsibility upon that union which almost automatically does away with hasty and ill-considered action, and it eliminates special privileges. In the case of the brotherhoods, the records show that they have risen to the occasion and have assumed and lived up to the duties which the recognition of their orders necessarily involved, with marked benefit to themselves and to the railway companies.

The recognition of the corporate unity of the employees, which does not hamper the liberty of the individual, has a tendency, if one may so say, to standardize practice and methods of treatment in many ways. When the representatives of the company and the authorized representatives of the employees come together, each has an opportunity to carefully review the matter in question from their respective standpoints, and each side avails itself of the best and wisest opinions of men in their own order. Under such circumstances the meeting, held in good faith and good will, becomes practically an adjustment of differences in which wild clamor and peremptory denial are entirely absent, and the economy in point of time, money, together with the establishment of reciprocal feelings of confidence and loyalty, are above price.

## Wasteful Practices.

In a paper read by Mr. D. C. Buell at the Traveling Engineers' Convention on "Waste of Energy in Railroad Operation," a startling picture is drawn of the waste that results from ignorance, carelessness, indifference and recklessness on the part of those engaged doing railroad work. The indictment made by Mr. Buell applies most directly to people engaged in the mechanical departments of railroads, but those in other departments are just as blameworthy, although few of them have the opportunities for throwing away or abusing things representing property as the motive power men have. We pub-

lished Mr. Buell's paper entire in our October issue and we earnestly urge those who are in the position to save or waste material to give the paper a careful study.

The tendency to wasteful practices is the curse of this generation. Some statistician with an aptitude for figures and a taste for startling investigations has discovered that if all the waste of the world since the creation could now be collected it would support the present population for one hundred years. Coming closer home another economist is found who declares that the sewage wasted in the United States every year would pay over half the interest on the national debt. However, like John Gilpin's wife, the nation may soon be in a position to bear the accusation of having "a frugal mind," for there is a tendency to utilize products that were for many years accounted as only so much embarrassing and useless material. Gas tar, for instance, was one of the greatest nuisances with which the manufacturer had to contend two or three decades ago. It could not be turned into streams, for it choked the channel and poisoned the water; it could not be buried, for it sapped the life from vegetation. Some one then experimented with it with the result that from this one-time useless product there have come several powerful disinfectants, and a saccharine product that is three times sweeter than sugar.

Thousands of other practices of throwing away as useless, things that are really priceless treasures, will be stopped when knowledge vanquishes criminal ignorance.

## Adjusting the Deflector.

There is no exact rule or method of adjusting the deflector or diaphragm sheet in the smoke box. Once having the smoke stack and exhaust pipe exactly in line and of the proper size the rest is largely experimental. Fortunes have been spent in experiments in the smoke box, but a deflector sheet extending at least half way over the flues and an adjustable apron which may extend the covering still further is universally acknowledged as a primal necessity both in the matter of economy of fuel as well as aiding in the steaming qualities of the engine.

The condition of the fire is the real test of the proper fitness of the apparatus in the smoke box. If the fire burns particularly hard at the front of the fire box, it shows conclusively that the movable apron is too low, and that there is a sharp draft passing through the lower flues. On close examination it will be found that the upper flues will become choked more rapidly than in the lower section. In moving the adjustable apron it may be stated that it is better to make the change a very small one and carefully note the effect. The evenness of the condition of the fire



in burning is the end which must be attained by all smoke box adjustments.

It has been repeatedly noted that there is a tendency in the construction and repair departments of railroad shops to fix certain specific dimensions in the opening of deflector sheets, the space from the bottom of the smoke arch and distance from the flue sheets being set down as absolute, in certain kinds of engines. This is a gross error, and the fact has been repeatedly demonstrated that conditions of fuel and even climatic conditions materially affect the steaming qualities of locomotives. In addition to this it need hardly be noted that the style of road itself and the traffic conditions are of material consequence, the varying amount of the loads to be drawn by the locomotive also affect the draft upon the fire and render the adjustment of the deflector sheet a more or less constant and delicate cause of care to the accomplished engineer.

A recent patented contrivance was described in our columns showing a series of circular openings in the deflector sheet controlled by a lever in the cab. The adoption of such a change would require the placing of an extra sheet of netting or perforated metal covering the deflector sheet as the holes would allow cinders of considerable size to pass through. Such an extra sheet, so placed, would be burned away very rapidly, and it appears to us that there is an opportunity for a contrivance which could readily move the lower edge of the deflector sheet without necessitating the opening of the smoke box door. When the vacuum occurs after each succeeding blast from the exhaust pipe the gases from the fire box rush instantly through the flues to the point where the greatest vacuum exists. This, of course, is on the lower edge of the deflector sheet and the position of this edge or line is the influence that regulates the evenness of the draft from the fire box through the flues.

#### Small Proportion of Utilized Heat.

The standard of heat energy is the thermal unit, and it is the amount of heat necessary to raise one pound of water one degree in temperature. The mechanical equivalent of the thermal unit is 778.8 ft.-lbs. With this statement

A pound of best bituminous coal gives up in burning 14,500 thermal units. Of these 2,900 are lost in the flue gases, 1,400 are lost by radiation, and the remaining 10,150 are utilized in the boiler. If the engine or steam turbine is of large size with high pressure, it will transform about 2,000 to 2,500 of these heat units into mechanical energy or about 15 per cent. of the original energy of the coal. If with this percentage of efficiency in the steam engine we undertake to transform the

energy into light by means of the incandescent light, we find that between 2 and 5 per cent. of this energy can be put into an electric light, or about  $\frac{1}{2}$  of 1 per cent. of the original energy of the pound of coal.

To recapitulate: About 65 per cent. of the heat energy of a pound of coal can be put into a boiler, and about 15 per cent. of it can be turned into mechanical power, and of this 15 per cent. from 2 to 5 per cent., or  $\frac{1}{2}$  of 1 per cent. of the original energy in the coal is turned into light.

The theoretically perfect engine is limited in its efficiency by the range of temperatures possible in practice, that is, by the temperature of the steam as it enters and leaves the cylinder. The theory of such an ideal engine is useful in that it shows the highest efficiency obtainable by a perfect heat engine. Between the temperatures now available in practice, the theoretical efficiency may be given as near 30 per cent., that is, about 30 per cent. of the energy of the steam is converted into work at the piston, but in actual practice this theoretical efficiency is never obtained even in the best engines. It is possible that an efficiency of 20 per cent. in the transformations of the energy of the steam by an engine may be reached, but an efficiency of 18.5 per cent. is the best that we have seen. It is only of late years that the efficiency of the engine apart from the boiler has been given in such tests. This efficiency is based upon the work done at the piston as shown by the indicator diagram, and it must be further reduced on account of the mechanical inefficiency of the engine. From 90 per cent. to 95 per cent. of the work on the piston given by the indicator diagram, as above, may be obtained at the brake in the best engine practice.

In reference to boiler efficiency, it can be stated that in the majority of cases the efficiency of the boiler does not exceed 70 per cent., though an efficiency of 80 per cent. has been obtained, that is, at least one modern boiler has converted 80.12 per cent. of the heat energy of the coal into energy in the steam when delivered to the engine.

To recapitulate again one may say, that in the best modern engine practice the following results are obtainable: 80 per cent. of the energy of the coal is transferred to the steam by the grate and boiler, 18.5 per cent. of the energy of the steam is converted into work at the piston, and 95 per cent. of the work on the piston may be had at the brake. This gives 14 per cent. of the energy of coal in the form of useful work, or 80 per cent. times 18.5 per cent. times 95 per cent. equals 14 per cent. This 14 per cent. is a very high efficiency and in ordinary practice no such efficiency is reached. It would require the fortunate combination of the best engines with the best boilers. In actual practice

the efficiency ranges from about 2 per cent. to the maximum. Good compound stationary engine plants consume from  $1\frac{1}{2}$  to  $2\frac{1}{2}$  lbs. of coal per h.p. hour. Taking the energy of coal as 14,000 British Thermal Units, this means an efficiency of from 12 per cent. to 7 per cent.

11. M. S. *Amphirite* consumed for maximum power 1.57 lbs. of coal and for medium power 1.43 lbs. per h.p. hour, giving on an average 12 per cent. of the energy of the coal in work on the propellers.

A London and South-Western express locomotive developed one horse-power per hour on 2.31 lbs. of coal, an efficiency of 7.1 per cent. These were the figures in a report made by Mr. Stroudley, under whose supervision the tests were made. The writer, who has experimented considerably with locomotives, found that they used from 4 to 6 lbs. of coal for every horse-power developed.

#### Stealing From Railroads.

One of the railroad combinations which we hear no shouting against is one formed by about thirty railroads in the neighborhood of New York to defend themselves against car thieves whose operations have been costing the railroad companies hundreds of thousands of dollars annually. The police of cities that the railroad companies are taxed to support give very little aid in arresting thieves who prey upon railroads. They regard that kind of stealing as many reputable respectable people regard smuggling.

At Fifty-ninth street and Eleventh avenue the New York Central detective office, in charge of Inspector Humphreys, has a regular Rogues' Gallery, where pictures and Bertillon measurements of a large number of railroad robbers are kept. These men, while they are habitual criminals, operate for the most part without the jurisdiction of regular police departments, and the burden of detecting and arresting them falls almost entirely upon railroad police. They do not hesitate to fight, and because there has been a good deal of bloodshed and sudden death on both sides there is a short shrift for the freight car thief who is caught in his work by a railroad detective.

The New York Central officials have a story that illustrates this. Their police had for months been on the trail of two brothers who were looting freight cars with a lot of perseverance and success. Finally they were caught almost red handed, and the railroad men rejoiced. Their joy was short lived, however, for the brothers, who had plenty of money to retain counsel, were acquitted without delay. They were caught again, and again released. A third time they were caught, but they made the mistake of showing fight, and a pair of bullets ended their careers.

**American Railway Association Meeting.**

At the recent semi-annual meeting of the American Railway Association, some very important matters came up for consideration. The committee on train rules and the committee on interlocking and block signals have for the past six months been working together as a joint committee on interlocking and block signals. The reason for including the train rule committee in this work is that signal and interlocking rules must be satisfactory from an operating as well as from a signal standpoint. The American Railway and Maintenance of Way Association and the Railway Signal Association are also considering the same questions and the joint committee above referred to have been in communication with special committees of both these associations.

This committee advised the Association that as a result of co-operation with the Interstate Commission, Messrs. E. M. Cooley, Azel Ames, Jr., E. G. Ewald and B. B. Adams, with W. P. Boland as secretary, have been appointed a block signal and train control board of experts to make an investigation regarding the use and rapidity of installation for block signal systems and appliances for the automatic control of railway trains. This board is to make experiments and tests in accordance with the resolution adopted by Congress in 1906 and for which \$50,000 was appropriated.

The result of the work done up to the present is that the standard code, as far as it relates to interlocking and signaling, has practically been found satisfactory and no changes have as yet been suggested. The joint committee are to continue their work for the next six months, and will probably make a definite report at the next meeting.

The committee on safety appliances reported progress in the formulation of a standard code of air brake and train signal rules which is being revised by a sub-committee.

The committee on car efficiency presented bulletins giving a statement of car surpluses and shortages on 86 roads from Jan. 2 to Oct. 2, and a comparative statement of car balance and performance. The first bulletin practically showed that the surpluses amounted to more than one-half the shortages, indicating that if but half of the surpluses had been utilized a good deal of the shortages would have been relieved; which would have resulted in increased freight earnings as well as large savings in per diem to the roads having the surpluses.

The second statement indicated that the "average miles per car per day" had only slightly increased in the yearly performance. The "average earnings," however, seem to be steadily increasing, which fact, taken in connection with the almost

stationary figures for mileage per day, shows an improvement in car loading or a decrease in empty mileage, or both.

**Mechanical Stokers.**

Ten years ago there seemed to be prospects that a mechanical stoker for locomotives would soon be introduced which would reduce the harassing toil that the modern heavy freight locomotive exacts from the overworked fireman. As the charging coal per unit of time that must be supplied to the fire box of a locomotive increases in weight, power firing will become imperative, but the sentiment in favor of putting artificial power to relieve human muscle progresses very slowly. The American Railway Master Mechanics Association may be regarded as the exponent of progressive railroad engineering sentiment, and it seems to us that its members have waxed indifferent on a subject that was decidedly alive three or four years ago. At the last Master Mechanics' Convention no formal report on mechanical stokers was made, which seemed retrogression, as it had been an

In 1904 Mr. J. F. Walsh, superintendent of motive power of the Chesapeake & Ohio, made a report to the Master Mechanics' Convention in which he said:

"The automatic locomotive stoker is, I believe, about five years old, and was first arranged as a hand device, the coal being thrown into the hopper by hand by the fireman, and then forced from that into the fire-box by hand. Later on, it was built over into a steam machine, the varying strokes of the machine receiving their force from three different valves, controlled by cams. That proved unsatisfactory on account of the cams becoming loose on the shaft. Then this was proved further on by the introduction of a rotary valve, and so far as the mechanism of the stoker is concerned it is quite simple and can be very easily handled for repairs or examination. The stoker has been used to a very limited extent comparatively, and I believe the road with which I am connected has made very much more use of it than any other railroad. We have a few of them at present, and only a few of that few in service, on account of the numerous transfers that have been made in the last six or eight months in our power from one district to another. But our observation in the use of the stoker is, as we say in the committee's report, as to the matter of saving fuel. Over the work done by an expert fireman it will run from 5 to 8 per cent.; over the ordinary fireman, it will run very much more than that. So far as the emission of smoke is concerned from the engine with the stoker attached in working order, it will easily do away with from 50 to 75 per cent. of the smoke. It very materially reduces the work of the fireman, it removes him from exposure to the furnace heat; it does away

to a very great extent with his using the slash bar, and consequently makes it, even where the ordinary stoker is used, where the coal is thrown from the tender into the hopper—reduces the work of the fireman very materially. The firemen readily admit that, but at the same time quite a number of them look at the stoker with suspicion. They appear to think that the stoker was intended to pave the way for the introduction of a class of labor which could be hired very much more cheaply than that which we now have. That, of course, was an entirely fallacious idea, but it was one of those things that accompany the introduction of anything of this kind. In our experience with the stoker, we find that it reduces the necessity for repairs to flues very materially. We have run our G-6 engines with the stoker applied—that is, a 22 x 28 in. consolidation engine, for three weeks without ever having to make any repairs to the flues. That is quite unusual, where the stoker is not in service. In the use of the stoker, again, one of the advantages that we find is the regularity of steam pressure. We have had the stoker on some of our largest passenger engines, and find where any care at all is taken in the regulation of the stoker, that the engine will go from one end of a long division to the other with practically no variation at all in the steam pressure, thereby enabling us to get the maximum power from the engine the entire length of the long division. The service in which we find the stoker most valuable is on the long fire-box engine running over a long division, pulling anywhere from 2,500 to 3,500 tons of freight, where the fire-box door ordinarily would be opened two-thirds of the time, and the fireman exposed to that extent to the heat of the furnace door. We find this stoker most valuable on that kind of a district. It enables us to keep the fire clean longer than by hand firing, it reduces the exposure of the fireman to the furnace heat and gives us the benefit of the full tractive power of the engine over a long, continuous pull. The capacity of the stoker, as mentioned by your committee here, was represented in handling the stoker normally, and the capacity of the stoker over the representations made by your committee may be increased nearly, if not quite, 100 per cent. by the fireman, instead of placing the coal directly over the screws in the hopper, moving it toward the front end of the piston which drives it into the fire-box. But we did not want to appear as exaggerating the thing at all, and we have given you the capacity of the stoker as it would ordinarily be fired but it can be increased, as we find it, almost, if not quite, double this capacity by simply throwing the coal, instead of depending upon the screw working it forward to the piston, throwing the coal in front of the piston, or close to the piston."

The action of the Traveling Engineers

Association in their convention last September was in strong contrast with the action of the Master Mechanics Association. At the Traveling Engineers' meeting a very exhaustive paper was read by Mr. G. C. Grantier, a prominent member. It contained a very good history of what has been done with automatic stokers for locomotives up to the present time. Mention was made of seven automatic stokers having been used, some of them quite extensively. Particulars were given concerning how several of the stokers work and the paper concludes:

"I believe I am perfectly safe in saying that with a stoker properly installed and set in a tank, and coal prepared to a uniform size that can be handled by the stoker, the fireman can operate the engine with a saving of at least 33 to 50 per cent. labor, at the same time maintaining a uniform pressure of steam with a large reduction of leakage of flues and furnishing steam under all conditions better than can be done by hand firing and with a saving of fuel. A lower grade of coal can be used with the stoker than without. By this I do not mean that the grade of coal with 30 or 40 per cent. ash can be used successfully with a stoker against the fireman having the average run of mine coal.

"There has been a good deal of fault found by the fireman, not with the stoker, as many have expressed themselves as highly pleased with it, but with the additional labor of crushing the coal as finely as need be to go through the grating. I am of the opinion that the stoker has come to stay, as I know this one can do all that is claimed for it if the care is taken of it that it is entitled to. By this I do not mean that it will not fail if not taken care of. The method of distribution is solved, but it may be further simplified."

We commend to our readers a careful perusal of this paper which will be found entire on another page. It represents a line of progress which ought to be encouraged.

#### A Theory of Derailment on Curves.

The recent railway disasters on curves, notably at Salisbury, Grantham and Shrewsbury in England, have given rise to much discussion as to the effects of high speeds on curves. Among those who have discussed the subject is Mr. T. H. Brigg, an eminent engineer in Great Britain. This gentleman has put forward an interesting theory of why such accidents take place.

The centrifugal force of a train moving rapidly on a curve is compensated by the elevation of the outer rail of the curve, but there is, according to Mr. Brigg, another force acting, which is the real cause of the derailments. English railway coaches at the present time usually have long bodies and are mounted on trucks which gives flexibil-

ity in rounding curves. The bodies of the cars are, however, rigid and on a curve each car makes a considerable angle with the cars in front of and behind it.

The ends of the outside sills practically terminate in spring buffers, and on a curve those over the inside rail are strongly compressed while those on the other side are probably fully extended. Mr. Brigg's theory is that when the vacuum brake was applied to the train the engine and tender brake set first and these vehicles were the first to be retarded. The brakes applied throughout the train, but not before the rear part of the train had crowded forward, and each car touching, as it were, the corner of the next one ahead produced a side pressure on the ends of the cars sufficiently heavy to cause derailment. The train being composed of rigid units, like the links of a chain, buckled at the joints. Mr. Brigg thinks that if the brake had not been applied which checked the front of the train this buckling action would not have taken place and that probably the trains in question would have gone round the curves all right.

#### Reasons for Reductions.

In reply to many inquiries the following authoritative statement has been made by President Finley of the Southern Railway Company as to the reasons for recent stoppages of construction work and reductions in shop forces:

In some quarters it has been represented that work has been stopped and forces reduced as a measure of retaliation against adverse State legislation. In no case has this been true. Current railway income is insufficient to provide funds necessary for extensive improvements and betterments. These can only be provided for, now as in the past, by obtaining new capital. Present financial conditions and the present attitude of investors toward railway securities are such that it is impossible for the moment to sell railway securities on a basis that any business concern, managed in accordance with sound business principles, would be justified in accepting.

It has therefore been necessary to postpone many important projects for improvements. Only those will be pushed to completion at this time on which work has progressed so far that the public and the railway can receive the benefit of their completion at an early date. Other projects have not been abandoned, but will be carried out just as soon as conditions are such that the necessary capital can be secured.

An error is more dangerous in proportion to the degree of Truth it contains.—*Amiel.*

#### Life of Railroad Appliances.

With a view to arriving at a basis whereby they may act intelligently in making rates or correcting rates of which complaint is made by shippers, a power conferred upon it by the Hepburn Railroad Rate Act, the Interstate Commerce Commission have appointed a committee which has been charged with the duty of ascertaining the average life of a freight car, a railroad tie, a locomotive, a steel rail and the thousand and one other pieces of equipment that belong to a great railway system.

When the commission decided to make the investigation they secured expert assistance, and created a committee on depreciation, composed of Professor Henry C. Adams, an employee of the commission and one of the best known statisticians in the country; President Delano, of the Wabash Railroad; Vice President Knuttschmitt, of the Southern Pacific Company, and Theodore Hinchman, of Detroit, a well-known consulting engineer. The last named had charge of the work of making a valuation of the railroads of Michigan, which was one of the first States to embark on such an enterprise.

President Delano was selected because of his knowledge of the wear and tear on railroad equipment, and Vice President Knuttschmitt for the reason that he is directly in charge of the roadbed and equipment of the Southern Pacific.

#### Book Notices.

Practical Mechanical Engineering, a comprehensive treatise on steam machinery and apparatus, compressed air, refrigerating machinery, hydraulic elevators, gas and oil engines, turbines, etc. Edited by Carl S. Dow, S. B., assisted by expert mechanical engineers. Illustrated with over 2,500 drawings. 3 volumes, 720 pages each. 7 ins. X 10 ins. Published by the American Text Book Co., Philadelphia.

This new work is an important addition to engineering literature and takes its place at once as a standard work in a very important branch of engineering. The expansion of constructive work in the twentieth century is so great that it has necessitated specialization in engineering. Formerly there was but one kind of engineering. The engineer was supposed to know all that pertained to manufacturing, the generation and transmission of power, the construction of highways and water works and the development of mines. It is absurd to suppose that any man, however studious, could become expert in all these branches of engineering. The work is becoming classified and that which pertains to public works and the division of land is called civil engineering. The rapid development

and wider uses of electricity has called into being a new kind of experts known as electrical engineers. The designing, erecting and operation of power machinery and the superintendence of vast and varied industrial and commercial projects is the proper province of the mechanical engineer, and it is for those who are occupied in this important group that this book has been especially prepared.

It need hardly be said that the sudden expansion of many new industries requiring more or less engineering ability has called into action a large body of men whose early education has not been of the very highest, but whose natural ability and energy have enabled them to meet the requirements of the situation with a commendable measure of fitness. To such this book will be especially helpful and to the operating engineer, to those in charge of power producing plants, to stationary engineers and firemen and to railway men there is all the essential instruction and information to enable them to become acquainted not only with their own immediate branch of the engineering occupation, but to become familiar with new and wider fields and so become prepared for wider responsibilities.

The accomplished and scholarly editor has been peculiarly fortunate in gathering around him a cluster of men of marked ability, not only eminent in their profession as engineers, but all of them gifted with the grace of literary expression, telling in the clearest and simplest language the lessons they have learned. These embrace many professors of engineering colleges, editors of technical magazines and engineers in active employment, among whom we are pleased to see the names of Prof. F. L. Kennedy, Harvard University; Mr. W. H. Wakeman, Mr. S. H. Bunnell, besides many others, and also our own associate editor, Mr. George S. Hodgins. The contributors number twenty in all and each has handled his subject with a degree of completeness that leaves nothing to be desired. The paper, presswork and binding are of the best and the book is in every way deserving of great popular favor.

Balancing of Engines, Steam, Gas and Petrol. For the use of Students, Draughtsmen, Designers and Buyers of Engines. By Archibald Sharp. Published by Longmans, Green & Co., London and New York. 212 pages, cloth, \$1.75.

The correct balancing of engines has engaged the attention of many eminent engineers and excellent papers have been presented on the subject from time to time. With the exception of Professor Dalby's book there is no other extended

treatise on the subject. The work of Mr. Sharp is timely in the sense that it meets the requirements of that rapidly increasing class of engineers engaged in the development of the motor car engine, and the successful installation of steam turbines for land and marine use.

As is well known, the smooth running of an engine depends largely on two factors: an equable torque on the crankshaft, and good balance of the various forces of the engine. The analysis of the latter subject occupies almost the entire book. Much of the matter is entirely new and valuable from the fact that it is largely the result of extended experiments. The section devoted to the balancing of locomotives will be especially interesting to all engaged in locomotive construction and operating. The involved problem of the cyclic variation of the pull on the draw-bar and the hammer-blow on the rails at certain positions of the crankshaft is very clearly defined. The work is altogether an excellent one, and the publishers have presented the book in elegant and substantial form.

Machine Shop Work, by F. W. Turner.

Published by the American School of Correspondence. Price, \$1.50.

This book contains 200 pages of reading matter and has a large number of clear plain engravings. It abounds in interesting illustrations and valuable instruction in the use of all sorts of tools and machines used in the up-to-date machine shop, based on the study of the best approved types and methods.

#### Car Ferry on Lake Ontario.

Mr. W. T. Newman, general manager of the Buffalo, Rochester & Pittsburgh Railway, recently wrote to RAILWAY AND LOCOMOTIVE ENGINEERING, and as a matter of railroad news, enclosed a copy of a letter written to one of our contemporaries in New York. Writing to that paper under date of November 11th, 1907, and referring to the new car ferry to be used on Lake Ontario, he said:

"I have your favor of 9th instant enclosing clipping quoted below, and asking for official confirmation of same:

"The Buffalo, Rochester & Pittsburgh and the Grand Trunk have established a car ferry across Lake Ontario between Rochester, N. Y., and Cobourg, Ont. A steamer with capacity for 26 cars has been put in service and it is expected to be powerful enough to cut its way through the heaviest ice. Its ordinary speed is 15 knots an hour. The B., R. & P. has built a dock on the Genesee river, which is reached by its Charlotte branch. It is expected that the ferry will secure a good traffic in coal from the Pittsburgh district to points in Canada."

"This is practically correct. The boat was built by the Canadian Shipbuilding Company and is expected to be ready for sea to-day or to-morrow. The boat has been built in the interest of the Buffalo, Rochester & Pittsburgh Railway and the Grand Trunk Railway for the purpose of promoting interchange of business between Canada and our country and for effecting reduction in time.

"The boat is the largest ever operated on Lake Ontario, being 316 ft. in length, having 57 ft. 7 in. beam, and draft of 17 ft.

"While especially designed for the handling of freight both summer and winter, accommodations in keeping with the most modern sea-going vessels have been provided on upper decks for the convenience of passenger travel, comprising 32 staterooms, dining saloons, lounging rooms, etc.

"The boat will operate between Rochester and Cobourg, a distance of 60 miles, and we expect it will make two round trips each 24 hours."

#### Extending the Signal System.

The Southern Pacific has gradually developed and improved the operation of its signal system. The company's experience is that automatic signals increase the traffic capacity of the road. On its single track installation, of 4,035 miles, the standard arrangement is for signals in pairs at a sufficient distance to provide proper head-on protection. This is usually from 2,000 feet to half a mile. No distant signals are used for home signals between stations, for the reason that the system was designed to meet the requirements of comparatively light traffic and moderate speed. At stations and sidings there are distant signals for protecting trains standing on the main line.

This system is now being extended along with the enormous increase in the track under automatic block. Surprise tests of enginemen are made at frequent intervals with the result that there is very seldom any disregard of signals. No permissive movements are allowed.

When the signal installations already authorized are completed, the Southern Pacific will have 557 miles of double track, in addition to 4,035 miles of single track protected by automatic block. In addition to this there are 108 miles of track operated under the electric staff system, making a total of 4,700 miles.

Our minds are endowed with a vast number of gifts and totally different uses—limbs of mind, as it were which, if we don't exercise, we cripple.—*Ruskin.*

# Correspondence School

## The Electrical Controller.

By W. B. KOUWENHOVEN.

The purpose of any controller, whether it be employed in subway service or on a trolley or on an elevated electric railroad, is to govern the application of electric power to the motors. The controller handle governs the input of electricity to the motors in much the same manner as the throttle valve of the steam locomotive governs the flow of steam to the cylinders.

The engineer in starting the train does not open the throttle wide at first, he opens it slowly, only a few notches at a time, and the train is brought up to full speed without slip or jar, and at a gradual and uniform rate. The engineer has practically allowed steam to enter the cylinders, step by step. The controller on the Manhattan elevated trains for example must perform the same duty as the locomotive throttle valve, that is, it must apply the electrical power step by step to the motors.

The controller consists of a movable drum which is turned by the controller handle. This drum is divided into four metallic sections, which are insulated from each other. On each of these sections are mounted copper strips. As the drum is revolved by the controller handle, what may be called metallic fingers rub on these strips. These fingers are the contact fingers of the controller. When two of these fingers press on the same copper strip, the electric current can pass from one contact finger to the other, because the copper strip on the drum when touching each, completes the electrical circuit between the two. As the controller handle is moved to the various notches by the motorman it makes different combinations with the resistance coils and the motors. Thus the motorman is enabled to apply electric power step by step to the motors.

The object of this step by step application of electricity is similar to the gradual opening of the throttle valve on a locomotive. If the throttle be suddenly pulled wide open the driving wheels of the engine would slip, and the engine would make very slow progress along the track if indeed it would move at all. If the electric current was suddenly applied to the motors of a standing car the motors would revolve quickly for a moment, and cause the

wheels to slip and the main fuse would be melted, and the motors would be damaged, and as in the case of the locomotive, the car would not start. The gradual application of electricity to the motors is therefore essential, and the path of the current is through the resistance coils to the motor.

In large trains, such as we are now speaking of, the current from the third rail is not applied directly through the controller to the resistance coils and to the motors as is the custom on trolley cars. The current used by the elevated motor car is much greater than that used by the trolley car. If the controller itself handled this large current it would be larger than a big barrel and the copper strips which are mounted on the controller drum, and the contact fingers would have to

the contactor it attracts and raises a copper finger which closes the main line circuit and allows current to pass to the motors via the resistance coils. When there is no current passing through the contactor magnet, a spring pulls back the finger and breaks the circuit. The electro-magnets in the contactors are thus operated by what is known as the train line circuit. This circuit carries a small current which simply operates the contactors, which make or break the heavy current to the motors from the third rail. This is something like the pneumatic reversing gear applied to the Eric Mallet locomotive and other large engines. Such a gear does the heavy work for the engineer, and the contactors do the work of handling the heavy current for the motorman.



NEW YORK & MANHATTAN BEACH, OLD TIMER 2-4-6, MASON ENGINE.

be very heavy and strong. This would make it hard to operate and very clumsy. As arranged in type M, controller made by the General Electric Company, the copper strips and the contact fingers carry only enough current to operate a few small electro-magnets. These electro-magnets make the contacts or connections through which the large currents are fed to the motors, and these electro-magnets are what are known as contactors. There are thirteen of these contactors on each motor car. This type of electro-magnet was described in an illustrated article in our January, 1907, issue, and to this the reader is referred.

A contactor consists of an electro-magnet to which a small current is supplied through the action of the controller drum. When the current passes through this small electro-magnet of

As the controller handle is advanced notch by notch by the motorman, the different contact fingers rub on their corresponding copper strips and send small currents through the train line circuit to the successive contactors, which in turn make the different combinations of the resistances and the motors.

These resistances are placed beneath the car, and are called rheostats. There is an electrical law which states that when a current flows through a resistance part of the power is consumed in forcing the current through that resistance. In passing through a resistance coil, part of the current is transformed into heat. There are six of these rheostats mounted on the bottom of each elevated motor car. When the train is started all the current is sent through these rheo-

stats or resistance before it gets to the motors. Each resistance uses up some of the electrical power, and therefore only a small current reaches the motors, and the motor car starts gradually. As the speed increases the number of these rheostats through which the current flows before it reaches the motors is decreased one at a time. Thus the electrical power is applied step by step to the motors in a manner somewhat similar to that in which steam is applied to the cylinders of a steam locomotive.

On the left hand side of the top of the controller box is mounted the reversing handle. This reversing handle corresponds to the reverse lever of the steam locomotive. The reverse lever of the locomotive controls the position of the links and the slide valves, which in turn control the admission of steam to the cylinders. The motorman's reversing handle does not make the electrical connections for changing the direction of rotation of the motors itself, but by means of the train line, of which we have spoken, it controls a "reverser" which is operated by an electro-magnet like the contactors. This reversing device only furnishes a small amount of current to the electro-magnet of the reverser, which then makes the required movement and so effects the required connections, depending upon whether a forward or backward motion of the car is desired.

On starting the train the control switch in the motorman's cab is first closed, and the reversing handle is thrown to the forward position. The control switch energizes the train line which furnishes the electricity to operate the contactors and the reverser. The button on the top of the controller handle is pressed down and the handle thrown to the first notch. This button is a safety device which completes the train line circuit through the contactors. If the motorman should release his pressure on this button and allow it to rise, it would open the contactor circuits and they in turn would shut off the power from the motors, and the train would simply coast ahead, and eventually stop.

With the controller handle on the first notch, contactors numbered 1, 2, 3 and 11 are energized. They make the electrical connections that take the current from the shoe on the third rail and pass it through four resistances or rheostats before it is fed to the motors. This current passes through each rheostat in turn and passes then through each motor in turn, and the train starts slowly ahead. The motors are now said to be in series.

Two pieces of electrical apparatus are said to be in series when the same cur-

rent passes first through one and then through the other. In a compound locomotive, steam passes first to the high pressure cylinder where it is partly expanded, and from there it goes to the low pressure cylinder where the expansion is finished. The high and low pressure cylinder may be said to be in series because the same steam passes from one cylinder to the other. The two motors of the elevated train are now in series because the same current passes first through motor No. 1 and then through motor No. 2. This is called the first series position of the controller and corresponds to opening the throttle of the locomotive a few notches at the start.

When the train has reached a sufficient speed, the motorman moves the controller handle to the second notch. This cuts out one of the rheostats and the current now only passes through three of the resistances before it reaches the motors. This gives more current to the motors and they increase the speed of the train. This is the second step in the application of the power to the motors and is called the second series position.

As soon as the speed is high enough the motorman advances the controller handle to the third notch. Now the current only passes through two of the rheostats before it reaches the motors, and so there is more power for the motors and the speed of the train still further increases. This is known as the third series position. Next the controller handle is moved to the fourth notch. Now there is only one rheostat remaining in circuit with the motors and there is another increase in the amount of power supplied to the motors. This is called the fourth series position of the controller handle. The speed of the train continues to gradually increase.

The controller handle is now moved to the fifth notch. This cuts out the last resistance and the current now passes directly from the third rail to motor No. 1. After passing through motor No. 1 it passes through motor No. 2 and then to the running rails on which the wheels rest. This is the half speed position of the controller handle and is called the series running position. With the handle at this notch no current passes through the rheostats, so no electrical power is lost in them; all of the current going directly to the motors. It is easily seen that it does not pay to run the train on any of the first four series positions of the controller handle, because of the electrical power wasted in the rheostats with handle in those positions. If you had to start a water wheel with a stream of water from a fire engine nozzle,

you would have to waste some water by striking the buckets of the wheel on their edges until the wheels got going, then you could hit each bucket squarely with the full stream.

The controller handle is now advanced from the fifth to the sixth notch. This is called the first multiple position, and the current now goes through two rheostats before reaching the motors. If, when the compound locomotive reached half speed it was arranged that steam be fed to both the high and low pressure cylinders directly from the boiler at boiler pressure, the engine would be simple, and electricians would say that the cylinders were in multiple, each taking all the steam it could get.

At this sixth position of the controller, the electric power first passes through the rheostats and divides into two halves, one half going to motor No. 1 and the other half to motor No. 2. From both motors the power goes directly to the running rails and ground. The same current does not pass through each motor in turn as it did in series, but each motor now has its own separate electric current. The total current that goes through the rheostats at this position of the controller is about twice as great as at any of the first five series position. This increased power supply to each of the motors increases the speed of the train and is the sixth step in the application of the electrical power.

Passing on to the next three notches numbers seven, eight and nine, a resistance coil is cut out step by step and more power is thus fed to each motor at each successive position of the controller handle, until the ninth position is reached, when there is only one resistance coil remaining in the circuit. This cutting out of resistances step by step increases the power supplied to each motor step by step and so gradually increases the speed of the train.

When the motorman throws his controller handle to the tenth and last notch, the contactors cut out that last remaining resistance, and the electrical power is supplied directly from the shoe on the third rail to each motor. This is called the full multiple position or multiple running position of the controller. As the motors now receive their power directly from the third rail, no current is wasted as heat in the rheostats, and it is therefore economical to run the train on this position of the controller handle.

Thus we see that there are only two running positions on the type M controller of the General Electric Company. These are the series and the multiple. It does not pay to operate the train

at any of the other positions of the controller handle, because some power is wasted in the rheostats. Electrical power is applied to the motors in ten steps. Breaking the application of the power up, by steps in this manner produces an even start, and a fairly uniform acceleration of speed up to the full speed of the train. When the current enters with the controller handle on the first series position, it traverses about a mile of wire between the third rail and the motors. When the handle is in the last point in multiple, this distance is practically reduced to a few feet.

The train line through which the various contactors are energized is, as we have said, governed by the controller handle. This train line is extended throughout the length of the car and ends in what is called a jumper. Trailer cars are also equipped with a train line terminating in a jumper at each end of the car. When it is desired to operate several cars at a time, the jumpers are connected to each other by train line couplers, something as air hose are coupled together. This makes the train line continuous throughout the entire length of the train, and the contactors on the several motor cars which make up the train are operated simultaneously with the contactors on the motor car at the head of the train where the motorman is placed. By means of this train line, electricity is applied simultaneously to all the motors in the whole train and the train thus acts as a unit. The entire train may be operated from any controller box throughout its length, and if the controller in front car became inoperative, it would still be possible to operate the train from the second, third, or any of the following car controllers. In that case a lookout man would have to remain at the front to give signals to the motorman further back.

### Elements of Physical Science.

#### VIII.—WHEELWORK.

Whatever form machines may have they are merely combinations of the six simple mechanical powers already described. The main objects in combining them are to gain power or direction to the motion so that the machinery will do the work required.

It may be readily noted that the wheel enters more largely into the construction of machinery than any other of the mechanical powers, and a combination of a number of wheels is called a train. When there are only two wheels, the one that imparts the motion is known as the driver, while the one that receives the motion is called the follower. The methods of

transmitting motion from one wheel to another are of three kinds, either by the friction of their outer rims, or by a band, or by teeth. Wheels may be moved by friction on their smooth rims, but are generally roughened so that friction prevents the moving wheel from slipping over the one at rest, and motion is imparted to the one at rest. Wheels connected in this way work with little noise, but are almost useless where there is much resistance to be overcome, and hence they are not much used.

A band passing around the circumferences of two wheels is an excellent method, where convenient of transmitting motion. These wrapping connectors or endless bands or belts must be stretched so tight that the friction on the wheels must be greater than the amount of resistance to be overcome.

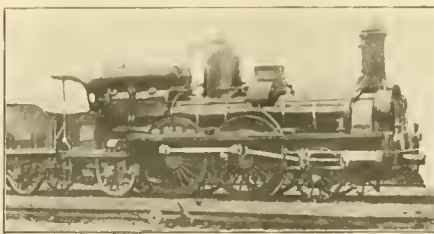

2-4-2 ENGINE ON THE P. L. M.

The flexible band has several advantages, among them being the pliability to move the two wheels in the same direction, or in opposite directions, as may be desired, the latter movement being accomplished by crossing the band between the two wheels. The motion imparted by a connector band has the advantage also of being almost free from inequalities, the stretching of the band readily adapting itself to any sudden variations in motion.

When wheels are moved by teeth on the circumference of each, the smaller toothed wheel is called a pinion, and the teeth are called leaves, and two or more wheels so connected are called a gearing, and are said to be in gear when they are arrayed so that the teeth work smoothly in each other. It may be noted that, as in all mechanical combinations, what is gained in speed by the use of wheels imparting motion is lost in power, and so power is increased by the reduction of speed. The element of friction consumes some of the power, ten per cent. generally being allowed as the loss incurred in large machines. The Shay geared locomotive is an excellent illustration of the gain in power by the use of toothed wheels, for while the speed is reduced the tractive effort is correspondingly increased.

Of toothed wheels there are three kinds in general use—spur wheels,

crowns wheels and bevel wheels. The teeth in spur wheels have their teeth perpendicular to their axes, and are either made in one piece with the rim or are fitted into the rim, and in the latter case are called cogs. Crown wheels, on the other hand, have their teeth parallel to their axes, and while running vertically communicate a horizontal motion to a wheel with which it is in gearing.

Bevel wheels are wheels whose teeth form any other angle with their axes than a right angle. Circular motion may readily be connected into rectilinear motion by the use of the rack and pinion, the revolving pinion moving the rack as the teeth engage each other.

Cranks are much used in machinery for converting rectilinear motion into circular or circular into rectilinear. The general form of the crank is by bending the axle. It will be readily noted that the point at which the reciprocating rod stands at right angles to the axle is a dead point where the crank loses its power for an instant, and it must be carried past this point by acquired momentum or other force.

Fly wheels are used for regulating the motion or momentum of machinery. It appears in various forms, but generally consists of a heavy iron hoop with bars meeting in the centre. It is set in motion by the machinery and its momentum prevents the motion of the machinery from varying to any great extent.

## Questions Answered

### TROUBLE WITH E. T. EQUIPMENT.

(100) S. A. D., Deer River, Minn., writes: I am running an engine equipped with the E. T. brake. When I make an application with the automatic brake valve a reduction of 20 lbs. in train pipe will only give a cylinder pressure of 20 lbs. on the engine and tank, and when the valve is put on lap, the brake will graduate off very soon, and in emergency full brake pressure will be obtained. Now, with the independent brake full pressure can be obtained, and it will hold fully with valve on lap. The distributing valve has been cleaned, but it did no good. There is a sound in the safety valve that sounds like the tolling of a bell, and I have tested all over for leaks in the distributing valve, but cannot find any. This seems to have us all guessing. What is the trouble?—A. It is likely that water has accumulated in the pressure chamber, consequently cutting down the volume of same to equalize with the application chamber, therefore, the low brake cylinder pressure with a service application. In

emergency the application chamber is supplied with air from the equalizing reservoir in addition to that from the pressure chamber, which would tend to build up a higher pressure in the application chamber. With the use of the independent brake valve air is supplied to the application chamber from the main reservoir to the adjustment of the reducing valve, and would give a brake cylinder pressure accordingly. The brake releasing with the automatic valve on lap is doubtless caused by a leak in the application chamber pipe, between the automatic and independent brake valves. By tightening the leak, adjusting the safety valve to proper pressure and draining any water from the pressure chamber, you will doubtless overcome the trouble you have had.

#### HORSE POWER FORMULA.

(101) J. L. L., Chambersburg, Pa., writes: Will you favor me with the horse power of a plain stationary engine of the following dimensions, also the formula for working out the horse power of an engine: Cylinders 14 x 20 ins., boiler pressure 110 lbs., revolutions per minute 140?—A. The formula for the indicated horse power of an engine is

$$H. P. = \frac{P L A N}{33,000}$$

where P is the mean effective pressure in the cylinders, say 85 per cent. of the boiler pressure in pounds, L is the length or twice the stroke in feet, that is the back and forward movement of the piston for one revolution of the wheel, A is the area of the piston in inches and N is the number of revolutions per minute. For your engine it works out to about 203 h.p.

#### WHAT IS THE LONG TON?

(102) W. H. P., Ibrox, Glasgow, writes: In reading through the numerous issues of your valuable paper I have noticed the term "long ton" on several occasions and not being clear as to how it is derived, I should feel obliged if you would kindly explain its meaning through your columns.—A. The term "long ton" is frequently used in this country to denote the British ton, which contains 2,240 lbs. The "long ton" is, however, used in the United States and is the shipping ton. The "long hundredweight" in the United States is 112 lbs., and is thus equal to the British avoirdupois hundredweight. The short ton of 2,000 lbs. is used for ordinary commercial purposes in the United States and Canada. The origin of the British weights, from which those in America are derived, is obscure. Writing in 1877, Piazzi Smyth, Astronomer Royal for Scotland, informs us that the 35th section of the Magna Charta, A. D. 1215, read: "There shall

be but one standard of weights, measures and manufactures: that for corn shall be the London quarter," and he adds, "the epoch of Magna Charta, instead of being primeval, is very middle-aged indeed, in the real history of British weights and measures." John Taylor, of London, in a work published in 1859 on the Great Pyramid of Egypt, points out the curious fact that "the quarter corn measures of the British farmer are fourth parts or quarters of the contents of the coffer in the king's chamber of the Great Pyramid; and the true value, in size, of its particular corn measure, has not sensibly deteriorated during all the varied revolutions of mankind in the last 4,040 years."

#### MALLET COMPOUND.

(103) L. H. E., Dryden, N. Y., writes: Please give me a good definition of a Mallet compound such as is described on pages 421-422 of your September issue—A. The name of the type of engine to which you refer is derived from a French engineer, Anatole Mallet, who first succeeded in having two small engines of this type tried on the Bayonne and Barritz Railway. These engines were popular in Europe on lines with sharp curves. The articulated or jointed feature is that with which Mallet's name is associated. This feature permits of the use of a maximum effective wheel base with a very much reduced rigid wheel base. The driving wheels are arranged in two sets or trucks. The front one is constructed so that while its cylinders take steam from the boiler and while it carries weight it is able to swing under the boiler so as to accommodate itself to curves.

#### SETTING WALSCHAERTS VALVE GEAR.

(104) F. S., Columbus, Ohio, writes: Being a subscriber of your monthly, I take liberty in asking you a question on the Walschaerts valve gear. What I want to know is how do they set these valves? Where do they make their changes in squaring up the valves? Where do they make their changes in giving it lead? A.—The valves do not require to be set as is the case with the Stephenson valve gear, where the valve is so far removed from the crosshead that changes in the position of the valve are constantly occurring. The proportions of the various parts of the Walschaerts gear must be exactly determined in advance, as they cannot be determined experimentally. No change should be made unless the effect is distinctly known beforehand. Generally speaking, there is no need of change. A large number of locomotives on the L. S. & M. S. Ry. have run over a year without any change of any kind of the valve gearing, other than a refitting of the brasses

on the return tank. The massive bearings and hardened bushings of the other parts render the accumulation of lost motion a very slow process, while the lead lever connected immediately near the valve, precludes the possibility of any organic change. In the event of any bending or breaking of the parts by collisions or otherwise, it would be necessary to refer to the drawings of the original design. The gearing should never be experimented with. If defects do exist they cannot be remedied except by changes in the length of the parts and this is the work of the constructor. It may be added that the lead is constant for any travel of the valve.

#### TEACHING OF STEAM ENGINE INDICATOR.

(105) Allen, Pittsburg, Pa., writes: In books on steam engineering the use of the steam engine indicator is highly commended, as a means of promoting heat economy. Locomotives are not economical users of steam, but indicators are very rarely used upon them to identify the causes of waste. Why is this thus? A.—Because an indicator diagram rarely indicates why a locomotive fails to save coal while using the steam economically. There are several reasons for this, principally through the action of the exhaust. What might be termed an ideal indicator card would show prompt admission, clean cut off, emphatic release, small back pressure and the line of compression following a little spout of steam chest pressure. We have taken and studied many such cards and with the best of them the fuel consumption was high, although the theoretical steam consumption shown on the card was low. We believe that the cause of this anomaly is the action of the exhaust steam. With an engine that makes a good card the steam shoots out like a rocket; with the mutton leg form of card the steam drags out slowly and has a minimum effect upon the fire. Another thing that the indicator card fails to identify is inefficiency of the boiler. When a card possessing features like one taken from a Corliss engine is taken from a locomotive found to be actually burning four or five lbs. of coal per horse-power developed and the source of waste cannot be ascertained, railroad engineers lost faith in the indicator and in engine tests.

A powerful steam fire engine for service on the South Indian Railway has recently been shipped from London. It is a Merryweather machine, of the double "Vertical Greenwich" pattern, capable of delivering 450 gallons of water per minute. Pole and sway bars for horse draught are fitted and the engine is equipped with all working accessories, including also 400 feet of extra double substance canvas hose.



# Air Brake Department

## N. Y. Automatic and Straight Air Valve.

The accompanying illustration of the general arrangement of the New York Air Brake Company's Combined Automatic and Straight Air Brake for locomotives will give an idea of the manner in which the different parts are connected. With this equipment it is possible to apply and release the engine brake independent of the train brakes, and to release the train brakes and hold the engine brakes applied by the manipulation of one brake valve handle. The pressure controller valve which controls the train pipe pressure is located

supplementary reservoir. Port T, by means of port J, is open to exhaust passage C to discharge pressure from the accelerator valve reservoir. Port E is also open, and pressure is free to pass to the driver brake cylinders and apply the driver brakes, until shut off by the reducing valve.

In automatic running and straight air release position air flows from chamber B into chamber A through ports M as in release position. Port E is blanked. Ports O, T and W remain the same as in release position. Ports R and V register with each other, thus connect-

train pipe pressure until cut off by the graduating valve, when the service reduction has been made.

In the remainder of the graduating positions, relation of ports remains the same with the exception of the restricted passage N in the slide valve, which in the fourth and fifth graduating positions is over the straight air port V, and should there be excessive piston travel or cylinder leakage the straight air equipment will hold the pressure in these cylinders to the adjustment of the reducing valve.

In emergency position ports J and K

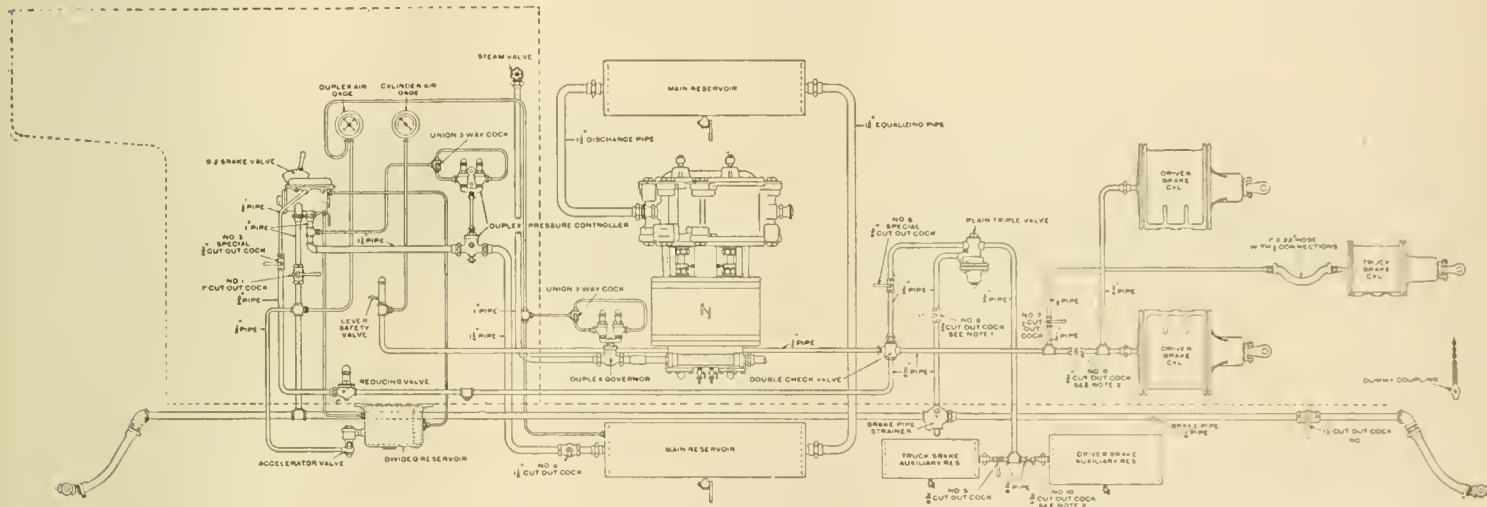

B2-HP., NEW YORK, LOCOMOTIVE BRAKE EQUIPMENT. FOR USE IN FREIGHT SERVICE.

between the main reservoir and engineer's brake valve, thereby confining the excess pressure to the main reservoir, making it impossible to overcharge the train pipe. The accelerator valve operates in connection with the engineer's brake valve and accelerates the reduction of train pipe pressure in service application, resulting in a more uniform application of the train brakes.

From our illustrations of the slide valve and its seat an idea can be had of the relation of ports in the different positions of the engineer's brake valve handle.

### RELEASE POSITION.

In full automatic release and straight air application position, shown above, air flows directly from chamber B (main reservoir) into chamber A (train pipe) past the end of the slide valve and through ports M. Port O is open to port J and exhaust C to return the equalizing piston, and port W is open to charge to

ing the straight air brake with the exhaust passage C, as shown, to exhaust the pressure from the driver brake cylinders.

In lap position all ports are blanked excepting port O. As in release and running position, this port is open to the exhaust passage C, and in this particular position cavity P is made use of to connect the port with passage C.

In the first graduating position ports M are blanked and communication from the main reservoir to train pipe is cut off. The straight air ports E and V are also blanked as well as ports O and W, which are cut off just before the handle reaches the first graduating notch. Ports F and G are open to the exhaust passage C to exhaust train pipe pressure, and port S is open through passage X to port T to receive pressure from the train pipe and pass it to the accelerator valve reservoir. The ports F and S will remain open to receive

are open to receive train pipe pressure from chamber A and discharge it through passage C to the atmosphere. Port V is open to maintain the pressure in the driver brake cylinders against leakage.

Ports E, F, G, O, R, S, T and W are lapped.

### Mysterious Brake Performance.

So much is said and written concerning mysterious and impossible air brake failures and happenings that one scarcely knows what to believe, whether the air brake is a magical device or not; when with a little diligent search and thought all this apparent mystery can be cleared.

One of the seemingly most mysterious performances is that of a train parting and the brakes failing to apply on the forward portion of the parted train and upon questioning any of the train crew they will always tell you that the angle

cock was wide open on the rear of the last car, but they never seem to know whether or not any air was coming from the train line hose.

Since we all know that it is a reduction in train pipe pressure that applies the brakes, what matters if the angle cock

**Testing Laboratory.**

One of the most complete railroad testing laboratories in the country has been completed at the new Omaha shops of the Union Pacific Railroad Company. The laboratories occupy part of the new shop office building, the

room for chemicals and supplies. The tables are covered with vitrified tile and the walls of the hoods are lined with white glazed tile. For this laboratory a complete equipment has been provided.

Besides the routine testing, inspection, and analysis of various materials

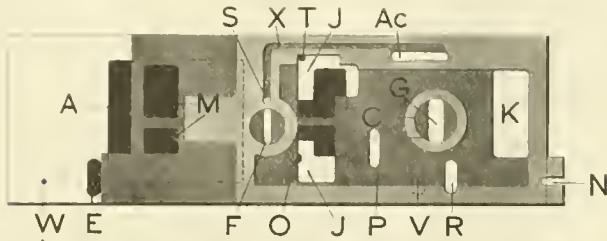

**RELEASE POSITION**

FIG. 1.

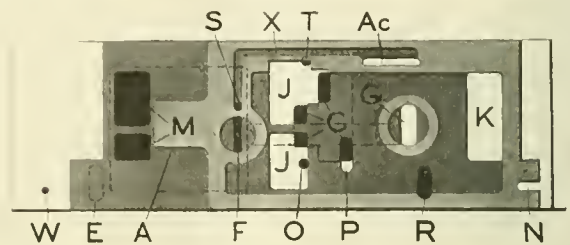

**RUNNING POSITION**

FIG. 2.

is wide if there is none or only a little air leaking from the train pipe.

It is certain if a leak is created in the train pipe as large as would be that of an open angle cock no 9½-in. pump would release the brakes with the brake valve handle in full release or running position until the leak is stopped. It would, there-

fore, seem reasonable that as the train parted the sudden freedom given the train pipe hose might cause same to fly and catch in some part of the draft gear, etc., kinking the hose in such a manner as to stop any flow of air through the hose or that the lining of the hose might fold over in such a manner as to plug the hose

offices of the chemist and engineer of tests and the test room on the ground floor being connected with the chemical laboratory on the second floor by an electric elevator. In the test room the machinery, all of which is electrically driven, includes a 250,000 lb. automatic machine for ten-

to ascertain if they conform to the company's specifications, its laboratory workers are constantly engaged in original investigations, both chemical and physical, into the properties of the various materials that come into railway engineering. One unique investigation carried out by this department

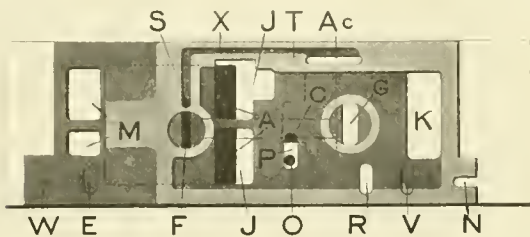

**LAP POSITION**

FIG. 3.

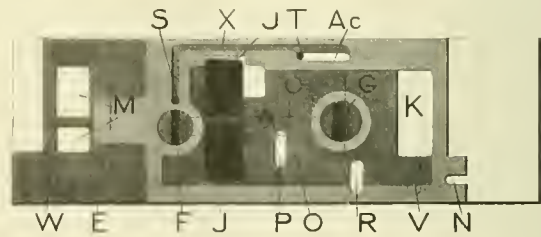

**FIRST GRADUATING POSITION**

FIG. 4.

fore, seem reasonable that as the train parted the sudden freedom given the train pipe hose might cause same to fly and catch in some part of the draft gear, etc., kinking the hose in such a manner as to stop any flow of air through the hose or that the lining of the hose might fold over in such a manner as to plug the hose

tests. The records of this machine are made autographically. A similar 50,000 lb. machine, milling machine, shaper, lathe, drill press, hack saw and bench grinder, are also part of the equipment of this room, which includes a complete set of apparatus for testing cement and soapstone storage tanks.

was a study of weed growth, the results of which partly determined the design of the company's gasoline weed burner, which we have illustrated and described in another column of this issue.

The inspection and test department of the Union Pacific has direct charge of details of various tests and inspections,



**LAST GRADUATING POSITION**

FIG. 5.

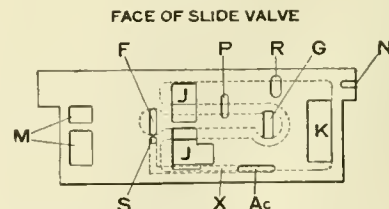

**EMERGENCY POSITION**

FIG. 6.

and stop the leakage. With either of the foregoing conditions, at the time the train parted, or very soon after, it is no more than a natural consequence that the brakes did not apply on the forward portion of the parted train. Failure to find the reason for these so-called mysteries does not necessarily mean there is no reason.

Every modern device for use in the work for which it is intended is included in the equipment of the chemical laboratory. In addition to the main room there are several special departments for photographic work, bacteriological investigations, electric experiments, a balance room, and a stock

not only on the Union Pacific, but also the associated Harriman lines. The inspection bureau has charge of the acceptance or condemnation of all materials purchased for the associated roads, including locomotives, rolling stock, and all maintenance of way materials, as well as for bridge structure.

# Patent Office Department

## FEED WATER HEATER.

Means for pre-heating the feed-water of locomotives has been devised and patented by Mr. F. M. Monahan, Middleport, Ohio. No. 860, 212. In the feed-water supply pipe there is a tubular housing

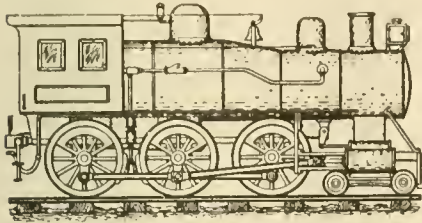

HEATER FOR FEED WATER.

open at opposite ends where it connects to the pipe, forming an inserted part of the same, the housing being provided with a lateral port open towards the side of the boiler and an upwardly extended part where it is also open. There is a screw cap fitted to this open part, with a check valve, and a short horizontal pipe connecting the housing with the side of the boiler.

## GRINDER FOR VALVES.

Mr. P. F. Pilander, Philadelphia, Pa., has patented a grinder for valves, No. 869,647. The device consists of a chuck

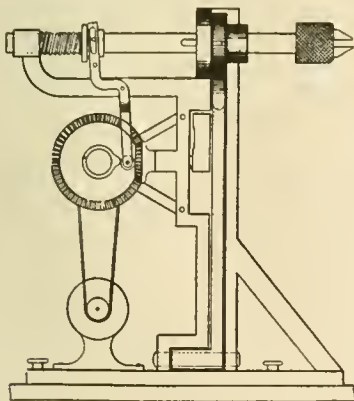

HANDY VALVE GRINDER.

spindle journaled in a frame, so as to slide vertically in its bearings and means for forcing the spindle downward. There is a lever adapted to lift the spindle and means for revolving the spindle first in one direction and then the other at pre-determined times relative to the raising and lowering of the spindle. A crank shaft is adapted to oscillate the lever.

## ELECTRIC CONTROLLER.

Mr. J. T. Thompson, Chicago, Ill., has patented a controlling apparatus for railway trains. No. 869,598. Means are provided for arresting a moving railway

train by a valve in the train pipe of the air brake system which is operated independently of the engineer's valve. There is an electric motor, the normally open circuit of which is designed to be closed through the medium of a circuit controlling device adjacent to the railway track and which is a part of the track service

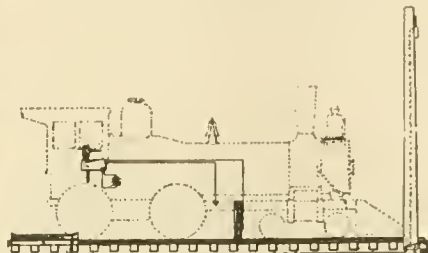

LOCOMOTIVE ELECTRIC CONTROLLER.

equipment and adapted to be brought into contact with the member carried by the locomotive as the locomotive passes.

## SUPERHEATER.

Mr. Max Toltz has secured a patent on an improved superheater No. 869,669. The device consists of two rows of enlarged flues in a locomotive boiler, in combination with horizontally disposed and divided saturate and superheated steam headers having their upper and lower parts relatively between the flues of the upper and lower rows of flues, respectively, suitable dry pipe and steam

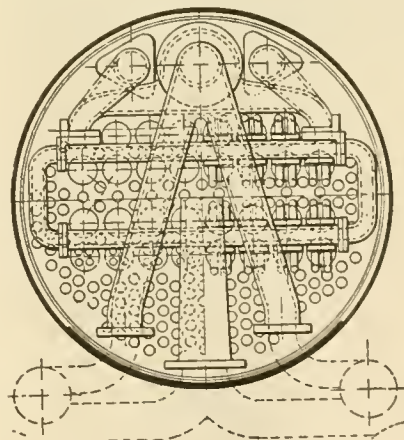

TOLTZ SUPERHEATER.

feed connections to the saturate and superheated steam leaders. Superheater elements are arranged in the flues and have their ends connected to adjacent portions of respective leaders.

## JOURNAL BOX LUBRICATOR.

An improved journal box lubricating device has been patented by Messrs. Harrison and Williams, Toledo, Ohio. No.

860, 131. The device embraces a combination with a cellar having end walls with curved top edges and movable side guards, a pan located within the cellar, and bowed springs for forcing the pan upwardly, the top edges of the pan be-

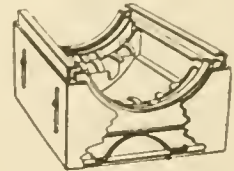

LUBRICATOR FOR JOURNAL BOX.

ing also curved. There are two waste retainers, one being located at each end of the pan, the retainers being provided with prongs for holding the waste in place.

## AUTOMATIC CONTROLLER.

Mr. A. E. Osborn, New York, N. Y., has patented an automatic controller for use on railways. No. 860,882. The mechanism consists of a cylinder located in the locomotive boiler and having each end open to the boiler pressure, the throttle rod extending through the cylinder, a piston attached to the throttle rod and located within the cylinder, and means for venting the pressure from one end of

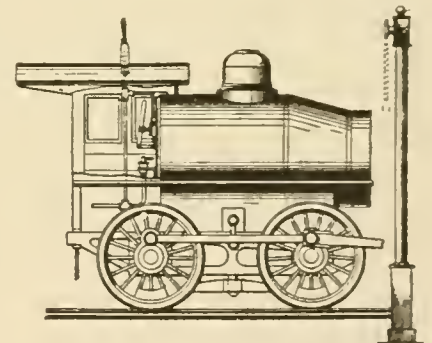

LOCOMOTIVE AUTOMATIC CONTROLLER.

the cylinder. There are means for operating the throttle rod located outside of the boiler and projecting beyond the locomotive for the purpose of venting the boiler pressure.

In an obituary notice of David Redfield Proctor, who died in poverty, the statement is circulated that he made a fortune from the sale of royalties on an invention which he patented to arrest and extinguish sparks passing through the flues of locomotives. We wonder who paid the royalties. The only device we know of was patented by a banker.

### Traveling Engineers' Convention.

(Continued from page 510 ante.)

#### REDUCTION IN COAL CONSUMED AND INCREASED EFFICIENCY OF MEN AND LOCOMOTIVES.

BY W. G. WALLACE.

The use of an indicator as an aid to the traveling engineer to determine the efficiency of a locomotive in service. This subject was taken up by a committee of which Mr. G. W. Wildin was chairman. It was before this organization, and reference to the proceedings, several pages of which are devoted to the subject, prove the thoroughness in which data was compiled and submitted in the report. On account of lack of instruments, the difficulty encountered in piping, and application of reducing motions to the different types of locomotives, and the numerous duties the traveling engineer is required to perform, the indicator has never come into general use in the manner outlined.

The most common methods employed and used as a leverage to increase the efficiency of men and locomotives is to arm the traveling engineer with a copy of the performance sheet for a previous month and a letter from the S. M. P. or M. M., calling attention to the poor showing or the unsatisfactory performance of the men and locomotives that have made a record below the average in miles run per ton or in pounds of coal used per hundred ton mile. As the performance sheet is made up after the completion of the month's service, the miles run received from the time keeper, and the ton or train miles from the car accountant, and then worked up by the office force, it is usually the 15th or 20th of the following month before the performance sheet is completed and the record in shape so that the men and locomotives making most expensive records can be located, after which time it will take the traveling engineer at least twenty or thirty days to investigate, make his recommendations, assist in making improvements, and report action taken on matters pertaining to the service sixty days ago. During this time he has heard all the complaints from the men in regard to cause, valves out of square, valves blowing, packing and cylinders in bad shape, flues stopped up, leaky steam pipes, flues and fire boxes, and the full list of excuses for a poor performance, many of which are justified. Then he receives a similar letter for the following month, and the same performance is repeated.

To say the least, such methods are discouraging to the traveling engineer. The enginemen begin to regard him as a fault-finder, shop-men as a kicker about getting work done on the locomotives, and his superiors do not see that he is of much benefit to the ser-

vice, but still retain him on the pay roll. The mechanical officers, on account of other important duties, often fail to give the support necessary in all cases and the company keeps on paying the bills for fuel, which, outside of labor, are the largest single items of expense in operation.

Therefore, it would appear that there is no more important duty after safety, time and service are cared for, than that of saving fuel. A poor showing is usually chargeable to the mechanical department and poor power conditions. The operating department is entitled to credit in proportion to reductions in overtime and delayed time, better train movement, train tonnage, handling of traffic, efficiency of train crews, etc., when the showing is favorable, and should also be considered when the performance is unfavorable.

The members of this association are steam locomotive men, and few, if any, have a desire to ride to the home of the friendless in an electric wagon. In nearly every electric power plant



ALPINE RAILWAY TRAIN CLIMBING THE SLOPES.

steam is used for generating current. Do they wait sixty days to learn the efficiency of the plant? Most assuredly not. You will find in many that engines are indicated frequently, coal and ashes are weighed, and the evaporation of water per pound of coal is recorded to determine the efficiency of boilers and engines, and any leakage of juice, as it is termed, is properly looked after and immediately remedied, and the cost of furnishing power is given out, showing the economy, which so far is in favor of the electric and against the steam locomotive. Without detracting from the very creditable achievements of our electric neighbors, if the same attention were given the consumption of coal and maintenance of steam locomotives and the losses looked after and remedied as promptly, would not reduction in coal bills and cost per hundred ton mile as well as improved power conditions necessarily follow?

It will require the united efforts of all departments to accomplish this result, and instead of beginning with the enginemen and traveling engineer and working up, the method should be reversed,

beginning with the general manager, who will entertain the proposition if it can be shown that it is profitable to the company, and working down the line with a system that would enable an inferior performance of either locomotive, engineman, train dispatcher or train man to be located very quickly, and authority from him to make expenditures for repairs and maintenance of the power in condition to obtain the desired reduction.

Your management will take but very little interest in an indicator card that will show a fine steam distribution unless it is followed by a reduced cost per mile or ton mile for fuel, and the indicator card from the perfectly adjusted valve gear would not indicate the efficiency of the boiler, adjustment of draft appliance, economical train movement, tonnage rating or the skill of the engine and trainmen in getting the train over the road.

Transportation officers are as much interested in the cost of conducting transportation on their respective divisions as mechanical men are in the locomotive performance. While the superintendents are asking for appropriations for improvements, such as reduction in grades, extension of double track, increased sidings and yard facilities, the motive power officers confine their energies to the maintenance of power, reduced shop expenses, cost of repairs, and often retaining a locomotive in service that a mileage made would warrant the expenditure for repairs on a mileage basis. Although in obtaining the necessary mileage the limit of economical operation is lost sight of and the result is engine failures, reductions of tonnage with increased cost of operation, each department suffers and the company stands the loss, while the distance increases between the officers of each department, at least, it seems greater. What can we do to close up the space or make it shorter? To bring out the best in the man and develop him is to become interested in him; give him responsibility that he will become interested in his duties to the extent that his best energies will be expended for his own individual benefit and that of his employer. When this point is reached, the man, regardless of his position, is entitled to his proportionate share of credit and it should be forthcoming.

Who is more competent to give information regarding men in train and engine service or condition of power than a good, bright train dispatcher? He can, by good train movement, make the performance a profitable one for the company and creditable to himself, or, on the other hand, cause fuel to be burned unnecessarily; the trainmaster in ordering trains from terminals at the most advantageous time made up in proper order to avoid unnecessary switching; the conductor who can get over the road that we all like to pull either in passenger or freight

service; the brakeman who looks after the leaks in train line and is alive; the station agent where freight is loaded as it should be and the switch list made out properly.

These men are the links in the chain that have not been considered in the performance sheet and an important part of the organization left out entirely in the question of pounds of coal used per one hundred (100) ton or car miles when it is used only as a comparison of engineers and sidetracked at a blind siding.

Why should not the Traveling Engineers' Association take this matter up and present it to our superiors in such a way that it will become attractive to them to such an extent that they will have it put into effect, making up a train and checking the speed, tonnage, work of the trainmasters, conductors, trainmen, station agents, overtime, delays and so forth, as well as the engineers and locomotives, on a basis of coal used per ton mile?

A few trips figured by the traveling engineer, showing why the same engine and engine crew used 12 lbs. of coal per 100-hundred ton mile one trip and 22 lbs. of coal the next, with his explanation proved by the time shown on the train sheet ought to convince the most skeptical that there is money or coal in it and that indicating men and locomotives by the coal account would develop a higher efficiency of both.

#### ADVANTAGES OF THE AUTOMATIC STOKER AS COMPARED WITH HAND FIRING.

BY G. C. GRANTIER.

In this paper on advantages of the automatic stoker as compared with hand firing I shall endeavor to give not only the advantages but the defects as well.

I have before me a large number of letters from members of the association and others interested in the subject, for which I wish to thank all concerned.

We have had a Victor, Kincaid, Lucky, Straus, Crosby, and Monarch stokers, mentioned as being able to fire an engine successfully. The Monarch stoker is operated either by steam or air and by a  $\frac{3}{8}$ -in. pipe connection. The coal is placed by the fireman with a scoop in the hopper and is forced by a series of pistons with varying strokes.

The information that I have been able to get on these stokers, outside of the one with which I am particularly familiar, is not given in detail, so I cannot describe each one, but I hope you will feel at liberty to do so here. The one on which I intend giving the most information is the one that we have been operating on our system.

All of the stokers are very similar in operation, either by a series of pistons or plungers which produce longer or shorter exhausts or strokes or steam jets, and tend to throw the coal closer to the flue-

sheets or the back end of the fire box and spread the coal very uniformly over the grate surface. Some of them use deflection plates to spread the coal.

The stoker we have on our division and in operation was installed last June and is known as the Hayden stoker. The method of operation is as follows: First the coal is taken from the tank by an elevator through a grating with 3-in. openings operated by a quadruplex engine, then passes into a conveyor and is elevated to the conveyor located over the fireman's head and is dropped into a hopper over the fire-box door by a worm screw and falls by gravity through a slide gate opening in the top of the fire-box door on a table located just inside the fire-box door, 24 ins. long and 7 ins. wide, and is blown by a blast of steam varying in length as desired by five separate



SALEVE ELECTRIC RAILWAY IN SWITZERLAND.

nozzles or jets in the fire-box door, which have a tendency to cool the table and prevent its burning out. The center jet blows the coal toward the flue-sheet. The next two jets on either side are located to place the coal in the front corners of the fire-box. The two outside jets are located so that the coal will be distributed along the sides and the back corners of the fire-box. They are governed by separate valves to regulate the blast of steam through each valve by common steam valves and can be adjusted at will at any time. On operating this machine we found it desirable to run the front jet closed all the time, as it is not needed on the engine on which we operated it, the next jets a turn open and the back ones full open.

The steam that furnishes the blast to place the coal is controlled by a quad-

ruplex engine located on the back end of the boiler butt, which has a crank movement actuated by a screw-wheel, operating a control valve, which admits steam through a 1-in. pipe passing to the nozzles which are regulated by means of a globe valve. The control valve, as a general proposition, is only run one turn open and varies with the weight and amount of coal to be handled. The length of blast is governed largely by the raising or lowering of the latch on the trip valve and the rapidity at which the engine is run. The faster the engine is run the less coal is thrown at one blast. If desired the valve can be tripped by hand and all of the coal in the hopper can be blown into the fire-box. In fact, the fire can be covered black inside of half a minute.

The steam connection to the engine operating the stoker conveyor is by 1-in. pipes. The steam connection operating the stoker engine is by  $\frac{3}{8}$ -in. pipe, which is only open probably a quarter of a turn.

The efficiency of the stoker in distribution of coal as compared with hand firing can be better illustrated by referring you to the coal test recently made on our division. In this test the stoker had to compete with some of the best firemen we had on the division. Ordinarily coal used in service is 50 per cent. Blossburg, which contains from 15 to 35 per cent. ash, and 50 per cent. Dagus coal; but to be sure of getting a uniform grade of coal it was decided that nothing but the best Dagus coal should be used, as we have made a test both with and without a stoker. The engine was drafted for the mixed coal and stronger than it would have been if Dagus coal was to be used. If the mixed coal had been used, I am inclined to think that the steam pressure would have been more favorable to the stoker than it is in the present performance, but taking it all in all the performance was very satisfactory for an engine that had been out of the shop for ten months since having received general repairs and was in good condition for an engine that had been out for this length of time, although the motion work was slightly worn.

I have known this stoker, on various occasions, to fire an engine thirty and forty miles, and even further, without having to touch a rake or open a door, and on opening the door the fire was found to be absolutely level.

With the Monarch stoker it is claimed that the labor is reduced about one-third, with the Hayden it depends largely upon the condition of the coal. If the coal is sufficiently fine so that it will not be necessary to crack it up so that it will pass through the grate the work is about as easy again, and if necessary to crack it up the work is about as hard again. With the Monarch stoker, it is claimed, it is no labor at all to open the fire-box door, as the stoker can be easily removed by the fireman, provided it is necessary to open the door, and when the stoker is properly

adjusted it is not necessary to open the door as long as the steam pressure is maintained, which will be indicated by the quality of smoke and pressure of steam furnished. The same will apply to the Hayden stoker. Occasionally coal will pile up in some place in the fire-box, making it necessary that it be leveled down, and may be caused by a clinker forming or a little deviation in front of engine and holes in grates. All that is necessary is to close the hopper, blow the coal off the table and the door can be easily opened, and the fire leveled with a rake if desired. There is nothing to be removed and it is a very easy operation, nearly as much so as though the engine was being fired by hand, but if the stoker is properly adjusted it is not necessary very often. If the nozzles are not properly adjusted the coal will be banked in one place or another and the labor is immensely increased over hand firing.

The knowledge of the mechanism of the Monarch, I am advised, can be acquired by a competent fireman so as to handle it successfully after one trip. The same would apply to the Hayden stoker. Of course, the greater knowledge of the mechanism of the stoker, as well as any other machine, the better we are prepared to operate to the best advantage. The natural width of the fire-box at which the Hayden machine can be operated successfully, as given by the builders, is any fire-box that can be operated successfully fired by hand. The same applies to the Monarch. The fire-box we are operating you will find given in the description of the engine. It is claimed that the stoker can be operated in a Wooten fire-box the same as a single-door fire-box, by using two stokers.

As far as plugging the flues is concerned, we have practically no trouble. So far as leaky flues are concerned, we have had no failure of flues that could be traced to the stoker in the length of time it has been in operation with us (only two, all told), which has been ten or eleven months. In fact, the boiler men advise me that they have noticed on various occasions that the flues were practically clean when the engine came into the terminal and required no flue work, which speaks well for the stoker. The reason I give for this is that the coal is fed in such small quantities and properly prepared, so that if any coal is carried into the flues it is sufficiently fine as not to stop in the flues and clog up, with draft equal through all flues.

The ability to maintain the maximum steam pressure is better than with the average fireman, and I find that the tendency of engineers who have been running engine with stoker is to work the engine harder than for hand firing and this would get the train over the road in less time.

The efficiency of the stoker depends

upon the elevator being properly set and adjusted in the tank, and with the experience and knowledge of the machine I have had I believe it would pay every railroad company to see that their engines are equipped with self-cleaning hopper tanks, and if the stoker is to be used, so that the last of the coal in the tank will be run to the elevator if possible. This will give ample time for the fireman to watch the operation of the machine and signals, and the labor will not be burdensome to him. Heat will also be eliminated almost entirely so far as the fire-box is concerned by use of the stoker. I have noticed that where the stoker is used it is not necessary to clean the fire as often as with hand firing. I believe, as a general proposition, that the stoker produces less clinkers and if the grate has sufficient opening for air the gases and carbon will be burned and a more uniform pressure of steam can be maintained with a material saving in coal, as a higher temperature can be maintained in the fire-box.

The Monarch people claim that a lump of coal as large as a man's head can be used, which means run of mine coal. From my observation of the stoker any size of coal that will go through a 3-in. opening will give the best results and I believe that all will agree that when firing engines of any class if we have as uniform size of coal as possible, instantaneous combustion will take place.

We have tried the wash fine coal such as used by blacksmiths, but with very poor success. The stoker did equally as well as could be done by hand-firing, but I do not think it possible to use that grade of coal to advantage, as it lays very close and is liable to pile up, causing the fire to burn full of holes. To get best results the coal should be prepared, either by crushing or screening, before it is put on the engine, and coarse coal put on passenger engines. I do not think it possible to get the best results with any stoker unless the coal is conveyed to the fire-box by means of a conveyor, as it requires practically the same labor as would be necessary if the man was to fire by hand, with the exception of eliminating the heat; I believe that the additional care of watching the stoker will more than compensate for any elimination of heat that may be made by increased labor when the conveyor is not used.

If elevators or conveyors are used and properly set with a self-cleaning hopper tank so that the coal will run down and is properly controlled so that it will be prevented from plugging elevator, the decrease in labor will be very noticeable and will materially aid the fireman and insure his giving closer attention to the operation of the stoker and signals, with a material saving in fuel.

For the length of time this stoker has been in service on our division the repairs have been very light. The greatest

expense has been caused by the table burning out. I cannot give the exact number, but I should say eight new tables have been applied. The cross-heads on the engines have had to be reduced from time to time and some light repairs have been made, mostly pipe work. The stoker has been out of service at different times on account of not having the proper material on hand to repair it at once. Of course, this would be expected, having but the one in service.

In the winter one of the hostlers allowed the conveyor engine to freeze up, bursting one of the cylinders. The pipes should be properly insulated to protect them from the severe weather, as the condensation taking place is considerable. The stoker is furnished with five-eighths of a quart of valve oil for each 140 miles and requires one-fourth of a quart of engine oil.

I believe I am perfectly safe in saying that with a stoker properly installed and set in a tank, and coal prepared to a uniform size that can be handled by the stoker, the fireman can operate the engine with a saving of at least 33 to 50 per cent. labor, at the same time maintaining a uniform pressure of steam with a large reduction of leakage of flues and furnishing steam under all conditions better than can be done by hand firing and with a saving of fuel. A lower grade of coal can be used with the stoker than without. By this I do not mean that the grade of coal with 30 or 40 per cent. ash can be used successfully with a stoker against the fireman having the average run of mine coal.

There has been a good deal of fault found by the fireman, not with the stoker, as many have expressed themselves as highly pleased with it, but with the additional labor of crushing the coal as finely as need be to go through the grating. I am of the opinion that the stoker has come to stay, as I know this one can do all that is claimed for it if the care is taken of it that it is entitled to. By this I do not mean that it will not fail if not taken care of. The method of distribution is solved, but it may be further simplified.

#### More Pay for Operators.

As the result of the recent conference between the Long Island Railroad officers and a committee of the telegraph operators employed by the company the operators are to receive an advance of about \$5 a month. This will apply to both towermen and station agents. Some of the men were already down for an increase of pay of \$5 a month, and they will now receive one of \$10. The advance will take effect this month.

The company will also employ three men at each tower, instead of two, as at present, and there will be three shifts of eight hours each.

**Missouri Pacific 2-8-0 Engine.**

The Baldwin Locomotive Works have recently built fifty heavy consolidation type locomotives for the Missouri Pacific Railway. Of these 26 are equipped with Stephenson valve gear, and 24 with Walschaerts valve gear. Apart from this the two classes are alike. The cylinders are 22 x 30 ins. This design illustrates the present tendency to use a large diameter of driving wheel for freight service. These engines have 63 ins. driving wheels, which is not unsuitable for fast freight service, even on lines where heavy grades are encountered. The tractive power is 39,180 lbs.

These locomotives are equipped with single expansion cylinders and balanced slide valves. The steam chests are

driving wheels, the first two pairs being equalized with the engine truck in the usual manner. All wheels are flanged.

The boiler is of the wagon top type, with radial stayed firebox and sloping throat and back head. The barrel is built of three rings, the smallest being 74 ins. in diameter; the middle one is tapered. In accordance with the present practice of the Baldwin Locomotive Works the longitudinal seams are welded at each end. The dome ring has a welded seam on the top center line, with a liner inside. The mud ring is of wrought iron, double riveted. It is sloped towards the front and is supported on buckle plates at each end. In the matter of heating surface there are in all 2,916.8 sq. ft. in the boiler, made up of 173 in the fire-box and the

**Momentum**

There is a difference between what is called momentum and what is called energy. Momentum as defined by scientific writers is another name for moving force. Strictly speaking it is the amount of motion a body possesses, and is found by multiplying the mass of the body by its velocity in feet per second. Energy is the capacity for doing work and is expressed by the formula, half the mass multiplied by the square of the velocity.

In the article on the Electric Controller, which we publish in another column of this issue, the fact is insisted upon that the gradual application of power to a standing train is absolutely necessary in order to insure the best results. Take, for example, the cars

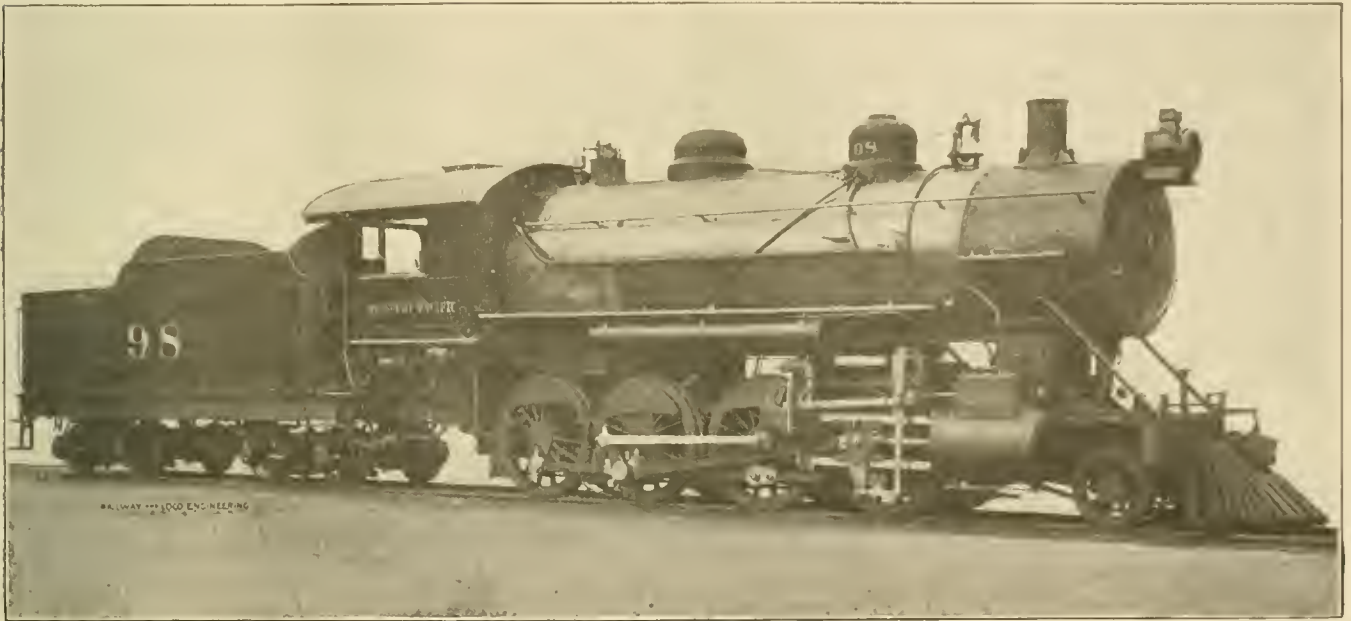

CONSOLIDATION TYPE ENGINE FOR THE MISSOURI PACIFIC.

G. W. Smith, Supt. of Machinery.

Baldwin Locomotive Works, Builders.

made of cast steel. The valve motion has been designed with due regard to simplicity and rigidity. The rocker shafts are secured to a bearer which is bolted to knees supported on the engine frames, and is also braced to the guide yoke. These braces serve as supports for the valve rod guides. The valve rods are actuated through cross heads which are secured to the inner arms of the rocker shafts. The guide yoke serves as a support for the link brackets and reverse shaft bearings. A single reverse shaft is used in this design. The eccentric cranks are split at the crank pin ends, and are clamped and bolted to the pins.

The main frames are of cast steel, 5 ins. wide, with double front rails of wrought iron. The brake hanger bosses are cast in one piece with the frames. The equalization system is broken between the second and third pairs of

rest in the tubes. The tubes are 15 ft. 6 ins. long and there are 340 of them. The grate area is 49½ sq. ft., which gives a ratio of grate to heat absorbing surface of very nearly 1 to 59.

The tender is made with a U-shaped tank, which holds 7,000 gallons and carries 14 tons of coal. The tank frame is composed of 13-in. channels and the trucks are of the usual arch bar style. Some of the principal dimensions are as follows:

Boiler—Type, wagon top; material, steel; thickness of sheets, 13-16 and 7½ ins.; working pressure, 200 lbs.; fuel, soft coal.  
 Fire Box—Material, steel; length, 108 ins.; width, 66 ins.; depth, front, 69½ ins.; depth, back, 60½ ins.; thickness of sheets, sides, 3½ in.; back, 3½ in.; crown, 3½ in.; tube, ½ in.  
 Water Space—Front, 4½ ins.; sides, 4½ ins.; back, 4 ins.  
 Driving Wheels—Journals, main, 10 x 12 ins.; others, 9 x 12 ins.  
 Wheel Base—Driving, 16 ft. 10 ins.; total engine, 25 ft. 6 ins.; total engine and tender, 60 ft. 5½ ins.  
 Weight—On driving wheels, 181,550 lbs.; on truck, front, 23,350 lbs.; total engine, 204,900 lbs.; total engine and tender, 349,000.

which make up the Lehigh Valley train, which forms the subject of our frontispiece illustration this month. The weight of the train, exclusive of the engine and tender, is 150 tons and at 44 miles per hour, it moves over 3,872 ft. in one minute. To get this heavy body up to the desired speed consumes a large amount of power, but that power must be applied gradually, or severe, if not destructive shocks might be the result.

If it were possible to devise and use brakes which would stop a fast train in a few feet, passengers would be injured and the cars damaged or destroyed. If it was possible to start a train from rest, and almost at once, attain a high velocity, very similar results would be produced. A bad start sometimes results in pulling out a drawbar, which would have stood the strain of a gradual application of power.

A curious application of this principle, which for want of a better name we may call the "gradual start," is found in nature. Mr. Harrold Bolce, writing in *Everybody's Magazine*, tells how the stormy petrel flies. The weight or mass of the bird is certainly very small, but the "gradual start" appears to be as necessary for it, as for an electric car or a modern express train. The story which follows is not only interesting but instructive. It incidentally shows the price paid for knowledge, which was the loss of three birds, to whom it was humanely desired to give freedom and the enjoyment of life. Mr. Bolce says:

"A naturalist visiting Algeria bought from a sailor four captive stormy petrels. They weighed about 1.65 pounds apiece, their wings were 5 ins. wide and had a spread of 4 ft. The ability of the petrel to breast the most furious storms has been universally admired. Its name is derived from its power of walking on the waves, like the Apostle Peter, and its courage and strength in planting its footsteps on the crests of the most tempestuous sea, have given a text to many writers. The naturalist, wishing to release his captive petrels, threw one of them into the air. It tried to fly but fell headlong, went crashing against a stone wall and battered out its brains. He took the second petrel to an upper story and launched it from a window, but, having no initial velocity, it, too, fell like a stone. The third bird he took to the top of an observatory, and pushed it out into space. It flapped its wings desperately, but nevertheless lunged downward and broke its wings against a post.

"The naturalist was now convinced that the stormy petrel's feats at sea are made possible because it first gets up momentum by running along the top of the water. Wishing to give the remaining bird a chance to demonstrate his theory, he took it out into a desert-like plain bare of grass, smooth as the surface of a calm sea. 'Here,' the naturalist reports, 'I set my fourth petrel down. It squatted at first and then turned with its beak to the wind and its wings outstretched, and started running, beating its wings, not hampered by any herbage. It ran a hundred yards, carrying its weight less and less on its feet, and finally on its wings, but all the time skimming the ground. At last with a single bound, catching the wind, the petrel rose 60 ft., careened around and flew past me overhead and glanced at me on its way, as if to say, 'Success in flight is all based upon momentum.'"

It's enough for a man to understand his own business, and not to interfere with other people's.—*Christmas Carol*.

### Snow Locomotive.

A snow locomotive has been patented by Mr. I. Q. A. Plavey, Bangor, Me. No. 864,106. The device comprises a locomotive body, furnished with a rotatable driving drum provided with a driving helix, a rotatable steering and

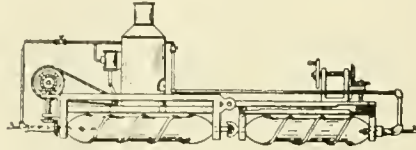

LOCOMOTIVE FOR USE IN SNOW.

driving drum provided with a driving helix, the steering drug being pivotally connected to the body for steering movement by free, effective lateral movement and means for laterally deflecting the leading end of the drum.

### Gasoline Weed Burner.

The Union Pacific Railway have recently built at their Omaha shops, under the supervision of Mr. W. R. McKeen, Jr., superintendent of motive power and machinery, a gasoline weed burner for the purpose of destroying the growth of weeds

low speed being geared from three to four miles per hour, which is the usual rate of travel when operating the burners, while the high speed gear, used in going from place to place along the line, enables the car to travel from 12 to 15 miles per hour without outside help.

Several tanks are situated on the car which carry a small supply of oil sufficient for a day's run on the road. Compressed air is used to force the gasoline to a series of burners situated at the rear of the car and near the ground, and while the frame mows down the weeds, it does not entirely destroy the growth, while the gasoline flame completes the work.

The frame-work supporting the burners is divided into three sections, the center one being about 5 ft. in width; the two remaining adjustable wings are attached to the center section and can be raised in order to clear cattle guards, etc. This machine burns the weeds for a distance of 3½ ft. on each side of the rails.

Twenty to twenty-five miles per day can be cleared by this weed burner, running about from three to four miles per hour. Three men are required for the operation of the car, it being run over

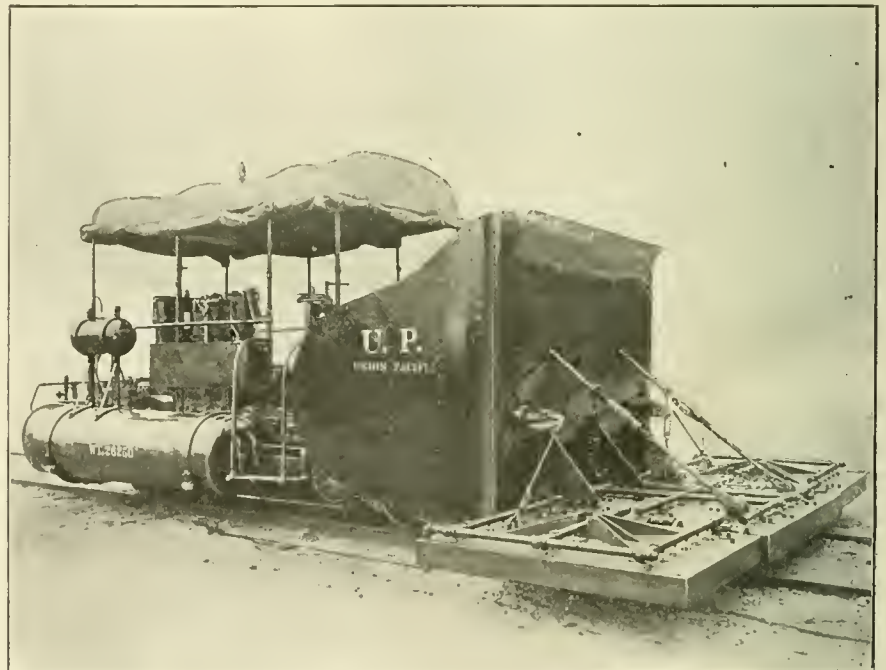

UNION PACIFIC GASOLINE WEED BURNER.

along the right-of-way. This machine is used very extensively on branch lines.

The car which we show in our illustration is made entirely of steel, mounted on a four-wheel truck, which is built in accordance with standard railroad practice. The car is propelled by means of a gasoline engine placed at one end, which also pumps air for distributing the gasoline in the burners, and raising the side wings of the burner frame. The engine is equipped with variable speed gears, the

the road under train orders the same as a work train.

Being forced to work, and forced to do your best, will breed in you temperance and self-control, diligence and strength of will, cheerfulness and content, and a hundred virtues which the idle never know.—*Charles Kingsley*.

Don't you know that the harder you are at work, the happier you are?—*Old Curiosity Shop*.



# Items of Personal Interest

Mr. S. W. Sudheimer has been appointed chief inspector of the Colorado-Utah car service associations.

Mr. E. E. Stone has been appointed to the new office of engineer of maintenance of way on the Boston & Albany Railroad.

Mr. James Carr has been appointed master mechanic of the Midland Valley Railroad, with headquarters at Muskogee, Ind. Ter.

Mr. J. B. Whitehead has been appointed purchasing agent of the Lehigh & New England, with headquarters at Philadelphia, Pa.

Mr. C. F. Ludington has been appointed chief fuel supervisor of the Atchison, Topeka & Santa Fe, with headquarters at Topeka, Kan.

Mr. J. J. Reid has been appointed master mechanic of the Missouri Pacific-Iron Mountain at Fort Scott, vice Mr. R. G. Long, resigned.

Mr. J. E. Cameron, superintendent of motive power on the Atlanta, Birmingham & Atlantic, has resigned and the office has been abolished.

Mr. K. M. McCarthy has been appointed purchasing agent of the Chicago, Rock Island & Pacific Railway, with headquarters at Chicago, Ill.

Mr. M. M. Dooley has been appointed master mechanic of the Alabama Great Southern at Birmingham, Ala., vice Mr. J. W. Evans, promoted.

Mr. W. A. Mitchell has resigned as assistant general foreman of machine shops of the Atchison, Topeka & Santa Fe Railroad at Topeka, Kan.

Mr. H. H. Woodman has been appointed purchasing agent of the Missouri Southern, with office at Leeper, Mo., vice Mr. E. J. Grimes, resigned.

Mr. William Elmer, master mechanic of the Pennsylvania Railroad of the Pittsburgh Division, is recovering from a severe attack of typhoid fever.

Mr. R. C. Evans, superintendent of motive power of the Western Maryland Railroad, has removed his headquarters from Union Bridge, Md., to Hagerstown, Md.

Mr. Wm. H. Lungren, superintendent of the Pennsylvania car shops at Todd's Cut, has been retired under the pension rules after 54 years' service with the company.

Mr. E. H. Smith has been appointed division master mechanic on the Boston & Albany Railway, with headquarters at

Allston, Mass., vice Mr. A. J. Fries, transferred.

Mr. A. J. Fries has been appointed master mechanic on the Boston & Albany Railway, with headquarters at Springfield, Mass., vice Mr. P. T. Lonergan, resigned.

Mr. J. N. Haines has been appointed inspector of transportation of the Lehigh Valley Railroad, with office at South Bethlehem, Pa., vice Mr. G. B. Minshull, promoted.

Mr. W. D. McDermott has been appointed master mechanic of the St. Louis South Western Railway, with headquarters at Texarkana, Tex., vice Mr. Frank Cain, promoted.

Mr. J. F. Graham, formerly superintendent of motive power of the Oregon Railroad & Navigation Company, has had his jurisdiction extended over the Cornallis & Eastern division.

Mr. Frank Cain, master mechanic for the Cotton Belt at Texarkana, Tex., has resigned to become assistant general master mechanic with the Houston & Texas Central Railroad at Houston, Tex.

Mr. J. Markey, master mechanic on the Grand Trunk Railway, has been appointed master mechanic of the Middle Division on the same road with office at Toronto, Ont., vice Mr. Wm. Kennedy, resigned.

Mr. H. R. Kight has been appointed master mechanic of the West Virginia Division of the Western Maryland Railroad Company, with headquarters at Elkins, W. Va., vice M. R. C. Evans, promoted.

Mr. F. L. Bleidinger has been appointed assistant to the first vice-president of the Lehigh Valley Railroad, with headquarters at 112 Liberty street, New York, in charge of the purchasing and fuel departments.

Mr. C. C. Barclay has resigned as district superintendent of the Pullman Company at St. Paul, Minn., to become connected with the mechanical department of the Northern Pacific Railroad at Livingston, Mont.

Mr. G. W. Sheasley, formerly foreman of carpenters of the Allegheny division, has been appointed master carpenter of the Monongahela division of the Buffalo & Allegheny Valley division of the Pennsylvania Railroad.

Mr. H. L. Roth has been appointed road foreman of engines, Cincinnati Division of the Cincinnati, New Orleans & Texas Pacific Railroad, with headquarters at

Ludlow, Ky., vice Mr. L. P. Lanahan, assigned to other duties.

Mr. S. B. Wight, formerly purchasing agent Michigan Central Railroad, has been appointed purchasing agent New York Central & Hudson River Railroad, with headquarters in New York, vice Mr. D. Fairchild, resigned.

Mr. W. H. Flynn has been appointed division master mechanic of the Michigan Central Railroad at St. Thomas, Ont., in charge of the mechanical department of the Canada Southern Division, vice Mr. G. J. Duffey, resigned.

Mr. Wm. Kennedy, formerly master mechanic of the Grand Trunk at Toronto, Ont., has been appointed superintendent of motive power of the Central Vermont, with headquarters at St. Albans, Vt., vice Mr. A. Buchanan, Jr., resigned.

Mr. I. N. Wilber, division master mechanic of the Chicago, Burlington & Quincy at Hannibal, Mo., we are informed, will retire on January 1st next, when he will have completed 50 years' service with the Burlington System.

Mr. W. I. Rowland, formerly general foreman, locomotive department, on the Baltimore & Ohio Railroad, with office at Grafton, W. Va., has been appointed master mechanic at that place on the same road, vice Mr. O. J. Kelly, resigned.

Mr. A. L. Moler has been appointed master mechanic of the Orange & North Western, the Colorado, Southern New Orleans & Pacific and the Beaumont, Sour Lake & Western, with headquarters at Beaumont, Tex., vice Mr. J. A. Baker, resigned.

Mr. L. D. Smith has been appointed assistant to the president of the Lehigh Valley Railroad, with headquarters at 143 Liberty street, New York, and 228 South Third street, Philadelphia, in charge of the financial and accounting affairs of the company.

Mr. E. A. Westcott, formerly assistant mechanical superintendent on the Erie Railroad, has been appointed to the new office of superintendent of the car department on the same road, and his former office has been abolished. His headquarters are at Meadville, Pa.

Mr. George A. Gallinger, heretofore traveling salesman for the Independent Tool Company, of Chicago, has been appointed manager of the Pittsburgh office of the same company, vice R. D. Hurley, deceased. The office is at 1210 Farmers' Bank Building, Pittsburgh, Pa.

Mr. S. T. Gallaway has been elected secretary of the American Locomotive Company, to succeed, in that capacity, Mr. Leigh Best, who has been secretary of the company since its organization. Mr. Best continues to hold the office of vice-president. The retiring officers were also elected to serve for the ensuing year.

Mr. H. B. Ayers has assumed his new duties as general manager of H. K. Porter Company, locomotive manufacturers, at Pittsburgh, Pa. Mr. Ayers comes well qualified to take up his new labors. For the last two years he has been in charge of the Canadian Locomotive Works at Montreal. He previously held the position of general manager of the Pittsburgh Locomotive Works.

Friends of Mr. George W. West, superintendent of motive power on the Ontario & Western at Middletown, N. Y., have learned with keen regret that his physical health had been impaired, but are expecting that he will have an early recovery. Mr. West was badly hurt in a wreck several months ago and had not fully rallied from the shock when he had a bad fall and was injured in going on board a ferry boat at New York.

Mr. W. G. Wilgus, formerly a vice-president of the New York Central, has been retained as consulting engineer for the work of the Detroit River Tunnel Company, which is engaged in tunneling under the Detroit River between Detroit and Windsor, Ont. Mr. Wilgus was actively identified with the inception of this undertaking and in the preparation of the plans, so that his services are of exceptional value. Having entered upon the business of a consulting engineer, this, in all probability, is not the only big enterprise with which he will be identified.

#### Plucky Act.

A plucky act was lately performed by Charles Rutledge, of Chester, Pa., a locomotive fireman in the employ of that part of the Pennsylvania Railroad, known as the Philadelphia, Baltimore & Washington. He saved the life of a little boy who was in imminent danger of being run over.

While firing the engine of a stone train near Port Deposit, Md., Rutledge saw a small child playing between the rails a short distance ahead. The brakes, though promptly applied would not have stopped the train in time, and the approaching engine had so frightened the little man, that instead of getting out of the way, he fell on the track. Seeing it all, Rutledge quickly made his way along the running board, and, with a flying leap from the front of the engine, reached the child, and pulled it clear just as the train swept by.

This plucky and timely act, in which Rutledge took great risk, has been brought to the notice of the high

officials of the road, and President McCrea and General Manager Atterbury have recognized the brave conduct of the fireman. He has also been warmly commended by Mr. E. F. Brooks, the general superintendent. It gives us pleasure to refer to this form of life saving, which is noteworthy enough to attract attention even in a field of duty where quick thought and action are always part of the day's work.

#### Obituary.

On Wednesday, Nov. 6th, there died at his home in Utica, N. Y., one of the best known and most popular railroad men in this section of the State, Michael James Prendergast. He was born in Utica on July 24, 1857, and at an early age entered the service of the Utica & Black River Railroad as a helper in the shops. He afterward became a fireman and an engineer in the service of the same company and, after its consolidation with the Rome, Watertown & Ogdensburg, and subsequently with the New York Central, he remained in the employ of those companies and always served them conscientiously and well. For 12 years past he has filled the position of General Foreman of the M. & M., and Mohawk divisions of the New York Central at Utica.

His loss, though widely mourned in railroad circles, is most keenly felt by those who were closely associated with him in business relations and these feel that their loss is one which can never be made up to them. He was a man of sterling worth, of genial and pleasing personality and a grand, big heart. It can not be said of him, more than of any other mortal, that he had no faults, nor that he made no mistakes, but the faults were so thoroughly balanced by admirable qualities and the mistakes always so frankly and freely acknowledged, that we can not remember that either ever existed.

His faithful and thorough discharge of his duties to the company he served won him golden opinions from those above him in the service and his justice, equity, thoughtful kindness and good nature in dealing with those under him made him respected and loved.

A man has gone out from among us who, though in a humble walk of life, Nature had made a nobleman, true, staunch and good.

FRANK S. CRESSON.

Utica, N. Y.

The death of George Richards, which occurred on October 23d last, removes one of the pioneer railroad men of this country. Mr. Richards died at the age of 80, and his life's record was one of resolute perseverance and of hard work

He was long known to railroad men as master mechanic of the Boston & Providence Railroad, but he had a peculiar career, even for a pioneer railroad mechanic. He went to the road in 1849 as a machinist, then he became a fireman for a short time and was soon advanced to be engineer, a position he held over five years. From that he was advanced to be foreman in the machine shop. While in that position the telegraph was introduced, and nobody at the station being able to operate the instrument, Mr. Richards learned telegraphy, and held the place of telegraph operator for several years. After that he returned to the shops as general foreman, and in 1870 was master mechanic. He remained in that position until after the railroad was absorbed by the Old Colony System.

It is with deep regret that we have to chronicle the death of Richard D. Hurley, manager of the Pittsburgh office of the Independent Pneumatic Tool Company. Mr. Hurley passed away at Chicago on Nov. 5th, and was buried on the 7th inst., at Galesburg, Ill., his old home. He was well known and had a large circle of friends in the New York, Pittsburgh and Chicago districts, particularly among those with whom his business connection had brought him in contact, and to them his death, after but a brief illness, will be a distinct shock. He was just thirty-nine years old, unmarried, and until a month of the time of his death he was entirely unaware of the heart trouble to which he succumbed. About a month ago he began to fail in health, and despite every effort to save his life the end came. He was a brother of Mr. Jno. D. Hurley, Vice-President and General Manager of the Independent Pneumatic Tool Company of Chicago, and of Mr. Edward N. Hurley, organizer and former President of the Standard Pneumatic Tool Co.

#### Trouble With Cam Brake.

On a switch engine equipped with the cam brake the brake would apply and release promptly on the left side of the engine, but the brake on the right side would not apply unless the piston was forced down by placing a bar between the crosshead and cylinder, then the brake would apply and release all right. After removing the pressure head of the brake cylinder it was found that the pipe nipple was screwed down into the cylinder far enough to bottom on the piston, thus blanking the opening of the pipe. By pulling down on the piston the nipple would be opened and air would enter the brake cylinder and apply the brakes. The nipple was taken out, a new one the right length was substituted and the brake worked all right after that.

### Pooling of Locomotives in General.\*

By D. R. MCBAIN.

That there is a relationship existing, either for good or evil, years of personal experience have left no doubt in the mind of the writer.

The pooling of locomotives, it must be admitted, has lost to the railroad companies an item of no small importance, the personal attention of some of its engineers and firemen, the commercial value of which may be measured to a certain extent by comparing the locomotive service under the pooling system as now existing and the service obtained when regularly assigned crews were the rule.

In making this comparison, however, we should not fail to take into consideration all of the conditions now existing as compared with conditions that existed in the days of regular crews. Without that being done, a fair opinion as to how much of the present day "grief" is chargeable to the pool can hardly be expressed.

To the writer the pool appears in all of its phases to be simply a step in advance of the old system. I say a step in advance, because of the apparent necessity and advancement, as I understand the word, is keeping pace with the times and providing a way when necessity demands a change. That the pooling of locomotives is a necessity, judging from the records of the 1906 convention, it would seem, is not very generally conceded or understood and a few reasons why it is necessary seems in order.

To begin with, we must not forget the contracts existing on nearly every trunk line between enginemen and railroad companies, many of which were made and were in existence before the pooling scheme became as general as it is now.

One of the items which did its share to force railroads to adopt the pooling was the "First in and first out" clause which with the advent of large power and the consequent frequent "hold in" for stay-bolt and other important work was an impossibility without the railroad being put to an unnecessary and heavy expense in the matter of paying for "all time lost," etc.

Another factor that should not be forgotten is that no matter how willing your men were to "follow their engines" it was an impossibility for them to do so and have enough rest to be safe men on the road. This made the maintenance of an extra list, which had to be varied in size to suit conditions and which, owing to fluctuations that could not then nor now be controlled—such as storms, congestions of traffic, the "summerman," etc., was a very difficult and unsatisfactory arrangement to both the company and the extra men alike; in short, the time had come when the practicability of one crew

operating an engine in through freight service to advantage had passed.

The last and perhaps the most important reason for the pooling of locomotives, is simply that no railroad corporation in competition with other lines can afford to invest several millions of dollars, in order to provide "regular" engines for all their men when such an investment can be avoided by pooling. In short, the writer takes the position that pooling of locomotives is not only necessary, but is a sound scheme financially and the degree of success attainable entirely up to the management, who may or may not provide adequate facilities and will get just what they pay for, assuming, of course, that the supervision of shops and roundhouses is good, in the absence of which money and facilities will not produce results.

What is needed most to make pooling a success, is a determination on the part of mechanical officers, from the superintendent of motive power down through the list in their order, to take care of the power regardless of whether the enginemen help any or not. Depending on such help and not getting it, is not a good excuse for not having power in good serviceable condition; the better plan is to do all the work reported and all that appears necessary, even though it is not reported. Every man in the official organization of a shop or roundhouse should be a "will-er," not a "can't-er." There is no room for the latter class of men in an up-to-date organization.

The amount of help you can expect to get from enginemen is usually controlled by the amount they are able to give. Very few men who profess to be engineers and expect to get along, will fail to report work in one form or another to the extent of their knowledge. What they do not know they cannot be expected to report, and from the fact that it is well known to all of us that firemen do not have the opportunity to learn to handle an engine that they had 10 or 15 years ago and from the additional, and perhaps more important fact, that the power of the present and the service expected as compared with the past period, is very different, we should be careful not to expect too much.

Right here is where the road foreman of engines ought to shine. Usually men are selected for these positions (R. F. of E. and T. E.), who are successful engineers, who are skillful men and who are thought by their superiors able to impart such information, as their success and skill would denote, to the rank and file of enginemen where needed. The tremendously skillful man is not necessarily the most successful, as he is likely to give his men the idea, once expressed in the hearing of the writer by a conductor, who was about to start on his first trip

and "what he said must go, right or wrong." A better man for the position of road foreman of engines or travelling engineer is the man who will do his best to impart to his men such useful information as he is sure of, and discuss with them any other point and not make a decision until he *knows*.

"Success and skill" are not all that is essential in a road foreman or travelling engineer—good judgment, a cool head, a temperate tongue and a "thick skin" are perhaps the best assets he can have, as without them he is not likely to possess the art of "approaching," in a satisfactory manner, the rank and file of enginemen with their various dispositions.

One thing to remember is, that if a man does not know, he cannot be "cussed" into knowing, especially if you have only a short time in which to give him the treatment. A better plan is to await an opportunity, and not let it pass when it comes, to talk with the man in a quiet and deliberate manner and do your best to give him such help by way of instruction and advice, as will enable him to do better in the future. These are the correct lines to work along and if results cannot be obtained in such a manner, better drop the man, as the "cussing" process sometimes results in embarrassment to the "cusser." One very successful man in the motive power world, on one occasion upon hearing from the writer a story of a hard "battle," remarked: "Mac, it is not a bad idea to keep your course directed along the lines of the least resistance so long as you make your point." The remark impressed me and "hard battles" have been on the decrease ever since. In "approaching" a man or men on any matter, either on or off the engine, it pays to forget for the moment the "dignity of your position," as to remind an ordinary man of that on short notice sometimes has the effect of stirring up the same feeling in the other fellow, and, besides, if the road foreman of engines or travelling engineer is a big enough man for the job he holds, the "dignity of the position" will cause him very little trouble whether in thought or otherwise. The tendency of late has been to convert the road foreman of engines or travelling engineer into an inspector of engines pure and simple, while the purpose of the position in the first place was, and should be yet, to provide a person who could help the locomotive men by instruction or otherwise. Most of the "grief" with very young engineers in the pool is due to the fact that such men do not know enough of the business to enable them to avoid making "grief," and a conscientiously directed campaign on the part of the road foreman among these men, if the road foreman is of the right caliber, will produce results. In order to carry out such a campaign, however, the road foreman must make up his mind to

\*Read at Traveling Engineers' Convention.

make some night trips, as it is not likely he can always catch the man he wishes to help, on a day run; he should take his list of men and go with them one or more trips as the case may require, until he cleaned up the list. During such trips he should, with other things, instruct them as to reporting work and how to report it and not for a moment let them think that he is going to report the work himself. This latter idea has done its part toward the falling off in work reported by enginemen and it should be avoided by road foreman or travelling engineer who is seeking to "improve the locomotive service on American railroads." The road foreman should make such reports on the condition of his engines, as in his judgment are necessary, to his superior officers, especially when there is reason to believe that his superior officer has no means of knowing for himself, but for a road foreman of engines or a travelling engineer to follow up the detail of work, that ought to be reported by enginemen, in his reports and by so doing gradually get the enginemen to thinking that there is no need of their reporting it, is very poor practice and does not tend to his advancement nor does it help him in the estimation of the men over whom he has charge.

Enginemen, like all other men, are just plain every-day human beings, and it has been the experience of the writer that whenever anyone "can show them" they are just as ready to acknowledge it and show their appreciation by endeavoring to follow the lines suggested. There are a few, we must admit, that are beyond the point at which they could have been shown, but that is a matter that cannot be controlled and time usually finds such individuals on the "left behind" list.

To succeed is to study, and when one quits studying his business he should at that time make up his mind that he attained his limit of success, and the next change for him is a start on the "toboggan," just as sure as day follows night. This applies to the engineman who cannot be "shown" and to all others in the organization from that individual up.

To be successful in pooling locomotives everybody from the top down in the organization ought to be a "will-er." "Will-ers" can organize and if forces are properly organized and intelligently and conscientiously supervised they will win.

Road foremen of engines and travelling engineers ought not to forget that they are instructors, not mere inspectors, and good instructors need never be without a good subject to discuss as the men will furnish the questions in abundant volume just as soon as they realize that the instructor is also an ordinary man who does not pretend to be beyond "showing." Hubbard says, "The only way you can enjoy what you have is by giving it away." The only way men in the locomotive ser-

vice may expect to succeed is by giving what they have in the way of information and being ready to accept from anyone who offers it anything that they have to offer—accept it anyhow, it won't do you any harm and it helps the other fellow.

Superintendents of motive power, master mechanics, road foremen and all others in the organization, be "will-ers" and act accordingly and you will find that the pooling of locomotives is not such a horror as it sometimes, and in some places, seems to be.

#### Medals Given at Jamestown.

The General Electric Company, of Schenectady, N. Y., have been awarded two gold medals and a bronze medal on account of their exhibit at the Jamestown Exposition. The classification by which the jury was governed in granting the awards limited them to one in each department, while previous expositions have allowed separate awards for each class of material exhibited. The General Electric Company's exhibits were grouped in three departments, viz: The machinery, the manufacturers and liberal arts and the mining departments.

A collection of motors applied to various machine tools and other devices has been awarded a gold medal. The arc and incandescent lamps and electric cooking applications exhibited in the departments of manufactures and liberal arts were also awarded a gold medal. The company exhibited a special motor designed particularly for use with an Ingersoll-Temple pneumatic rock drill, and this motor because of its peculiar adaptation to the special service was awarded a bronze medal. The company was also awarded a silver medal for installation of exhibit.

#### Lever Type Pipe Threading Machine.

This machine, which is made by the Stover Foundry & Manufacturing Company, of Myerstown, Pa., is designed to cut off and thread pipe from  $\frac{1}{4}$  to 2 ins. inclusive. The bed and headstock are cast together in one piece, insuring rigidity and stiffness for the bearings. This is very necessary in this type of machine, as the operation of the chuck causes a constant strain on the front bearing of the main spindle. The machine is equipped with an improved type of lever chuck, the gripping and releasing movement of the chuck being accomplished while the spindle is in rotation. The opening and closing mechanism is powerful, and the pipe can, therefore, be gripped with but little pressure applied to the hand lever, shown at the side of the machine. The chuck holding the ac-



## An Interesting Book on a Vital Subject

This is a brand new edition, just off the press: a little sixteen-page affair, illustrated, printed in two colors, with an attractive cover design, and, best of all, chuck full of valuable information.

In the first place it tells how Prof. Goss tested Dixon's Graphite on a standard air brake equipment.

It tells how to use Dixon's Graphite Air Brake and Triple Valve Grease and how it has been used by successful engineers. Winter is apt to increase troubles with the air system. Write for "Air Brake Lubrication."

Copy 69-1 Free

**JOSEPH DIXON  
CRUCIBLE CO.**  
Jersey City, N. J.

# GOLD Car Heating and Lighting Co.,

Manufacturers of

**ELECTRIC,  
STEAM AND  
HOT WATER  
APPARATUS  
FOR RAILWAY CARS**

**EDISON  
STORAGE  
BATTERY  
FOR RAILWAY CAR  
LIGHTING**

Largest Manufacturers in the World  
of Car Heating Apparatus

Catalogues and Circulars  
cheerfully furnished

Main Office, Whitehall Building  
17 BATTERY PLACE  
NEW YORK

tual gripping parts is entirely enclosed, thus avoiding the danger of catching the clothes of the operator.

The adjustment of the three gripping jaws is such that it can be made at any one of three points in the chuck, so that it is almost certain that no matter where the spindle tops, some one of these points will be in position to be used by the operator in setting the chuck. All parts inside of the chuck are made of steel. The machine has nine separate and distinct speeds, applicable for threading steel and iron pipe of the sizes within its capacity. It is driven by a single belt pulley and the change of speeds is obtained by a sliding gear and a clutch.

An improved type of nipple holder is used and consists of three pieces of hardened tool steel. They are placed in the same chuck in which the gripping jaws are, and open and close with the lever movement, to release or grip

sorted interchangeable steel cams for taking the thrust of the dies and adjusting them to their proper position. Hardened steel plates are also placed in the bottom of all the die slots; these plates resist the wear of the constant contracting and expanding of the dies and keep the lead of all the separate chasers correct. The front face of the head swings open, so that when changing chasers, they can be picked out of the head at any position on the cams, and others inserted in their place.

Two cutting off tools are used, both being operated by the same screw and handle. A universal adjustment is allowed for, so that both tools will always cut.

#### Made as Used.

A system of acetylene car lighting by the use of an individual generator for each car has been brought out by the Gold Car Heating & Lighting Com-

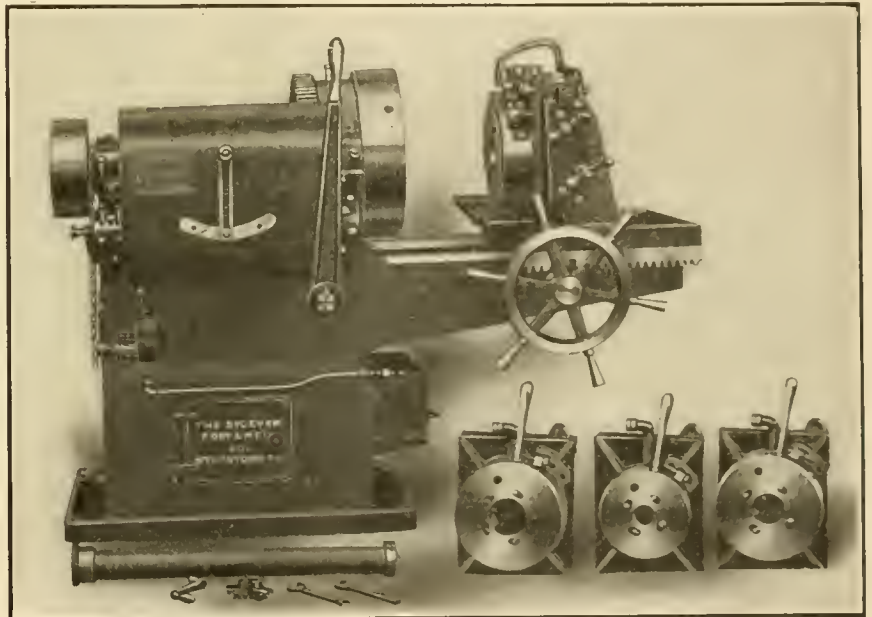

LEVER TYPE OF PIPE THREADING MACHINE.

the nipple while the spindle is rotating.

The die head slides on ways on the stand which supports it. Being free to slide, it will accommodate itself to any eccentricity in the pipe, relieving the dies of strain, and cutting an even depth of thread all the way round the pipe. It can be pushed to one side, so that it will completely pass the gripping chuck, and, in such position, the cutting off tools can be brought up very close to the gripping chuck, thus cutting off the shortest possible piece of pipe. By sliding the head out of the way, a pipe can be inserted in the machine equally well from either end, and when the head is pushed to one side, the pipe can be pushed through the stand without dragging it over the dies.

The die head is equipped with in-

pany of New York. This system does not require the use of a stationary plant; it requires only a supply of calcium carbide and water, which is provided at terminals and repair and cleaning yards.

The equipment consists of a generator which is a 12-in. cylinder extending from below the floor of the car, up through the car and just beyond the roof. There is a cylindrical water tank placed over the door of the car and inside, also a condenser in the corner of the upper deck and the necessary piping.

A charge of about 140 lbs. of "carbide" is put into the generator from the top. The carbide chamber in the generator extends downward a distance of about 3 ft. It terminates in a grating. The bottom of the generator is

filled with water and is connected with the supply tank over the door. By this means the water rises up to the level of the grating in the generator and here it comes in contact with carbide.

Acetylene gas is generated when water and carbide come together and a slight pressure of gas is thus produced. This pressure is sufficient to cause the water to recede from the carbide until gas has been used sufficiently to decrease the pressure, when the water again rises, generates gas and is forced down by the pressure. The rise and fall of water due to the fluctuation of pressure takes place regularly and constantly and thus the generation of the gas is dependent on the amount used. The gas is made as used, if one may so say, and in quantities which are directly proportional to the consumption in the car. When the carbide in contact with the water has been broken up in the process and given off all the gas it contains, it drops through the grate and falls to the bottom of the generator as ashes fall through a grate. This residue of consumed carbide thus automatically makes way for fresh carbide as the process goes on and it can be removed when the car is in the yard.

The condenser, receiver and regulator are used to insure pure, dry gas at all times and to produce a steady pressure throughout the piping system of the car. The generator is placed in the saloon of the coach and does not occupy valuable space and the rest of the apparatus is out of the way overhead. The train crews and porters turn on, light or turn off the gas just as might be done in a city residence. The supply of carbide and water is attended to by the car cleaners and the work of cleaning and changing is done when the car is out of service. Some very extensive service tests of this system have been made on the Great Northern and the Gold company will be happy to supply those interested with full details and data as to length of continuous operation, quality of light and cost.

The Pressed Steel Car Company and the Western Steel Car & Foundry Company of Commerce Building, Fifth and Olive streets, St. Louis, with Mr. W. P. Coleman and his assistant, Mr. C. D. Terrell, in charge. We are informed that business in the Southwest territory has increased so steadily of late that the management of these car companies have found it necessary to have representatives in the principal city of that section.

"Have you noticed, papa, how often mamma says 'And so on, and so on?'" "Yes, my boy; but it never applies to buttons."

**Hold-Fast Grease Cup Plug.**

A cleverly designed grease cup, got out by Mr. J. H. Lewis, locomotive foreman on the Chicago, Burlington & Quincy, at Chicago, has for its object the holding of the plugs in grease cups. In this cup the plug cannot work in and so prematurely use up the grease and it cannot slack back and thus fail to exert pressure upon the grease.

As is well known, the vibration of the rods shakes out a great number of these plugs, and Mr. Lewis has met this difficulty by inserting a thin strip of flexible metal in a recess in the jam nut, the strip being bent so as to adjust itself into one of four vertical grooves cut in the

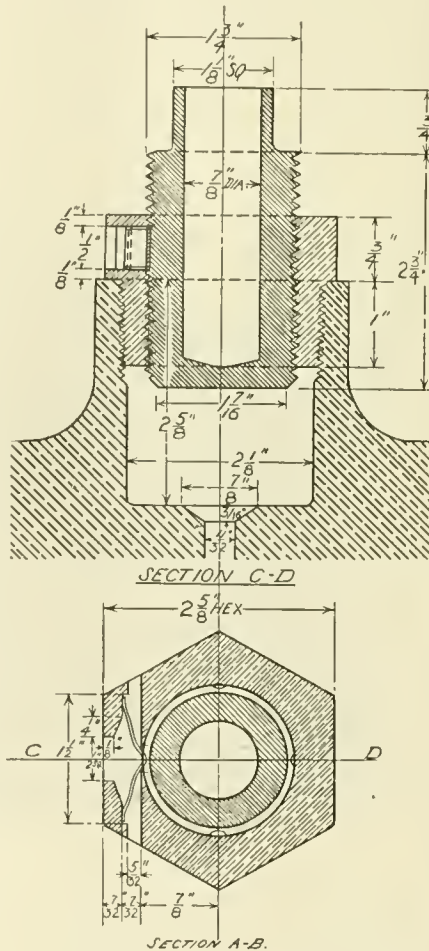

GREASE CUP WITH PLUG HOLDER.

thread of the plug. The flexible strip or spring is not stiff enough to prevent the screwing out or in of the plug, but is strong enough to retain the plug in position against the force of mere vibration. Not one plug has been lost since the adoption of this clever device. It is in fact what one might call a nut lock for the holding device on the plug.

An earnest citizen was making an impassioned attack on his city council. He said: "Let us go to the council not like a lamb, but like the wolf, and take the bull by the horns."

**The Best Railroad Books**

**Air Brake Catechism**

By Robert H. Blackall. The new revised, 1907 edition, is right up to date and covers fully and in detail the Schedule E. T. Locomotive Brake Equipment, H-5 Brake Valve, SF Brake Valve (Independent), SF Governor Distributing Valve, B-4 Feed Valve, B-3 Reducing Valve, Safety Valve, K Triple Valve (Quick-Service) Compound Pump. It is the Standard Book on the Air Brake. Contains over 2,000 Questions and Answers on the Old Standard and Improved Equipment. Price, \$2.00.

**The Walschaert Locomotive Valve Gear**

By W. W. Wood. If you would thoroughly understand the Walschaert Locomotive Valve Gear, you should possess a copy of this book, as the author explains and analyzes it in a most practical manner. Price, \$1.50.

**Locomotive Breakdowns**

By Geo. L. Fowler. Tells how and what to do in case of an accident or breakdown on the road; includes special chapters on Compound Locomotives. Better procure a copy, as it contains 800 Questions with their Answers. Price, \$1.50.

**New York Air Brake Catechism**

By Robert Blackall. The only complete treatise on the New York Air Brake and Air Signaling Apparatus. 250 pages. Price, \$1.00.

**Combustion of Coal and the Prevention of Smoke**

By Wm. M. Barr. Contains over 800 Questions and their Answers on How to Make Steam. Price, \$1.50.

**Link Motions, Valves and Valve Setting**

By Fred H. Colvin. Shows the different valve gears in use, how they work and why. Piston and slide valves of different types are illustrated and explained. A book that every railroad man in the motive power department ought to have. Price, 50c.

**Train Rules and Dispatching**

By H. A. Dalby. Contains the standard code for both single and double track and explains how trains are handled under all conditions. Gives all signals in colors, is illustrated wherever necessary, and the most complete book in print on this important subject. Flexible leather binding. 221 pages. Price, \$1.50.

**The Railroad Pocketbook**

By Fred H. Colvin. Gives clear and concise information on just the points you are interested in. It's really a pocket encyclopedia, fully illustrated, and so arranged that you can find just what you want in a second. 250 pages. Price, \$1.00.

**CHARTS**

**Air Brake Charts**

By Blackall. Shows passenger and freight equipment. Printed in ten colors. Price, 50c.

**Anatomy of a Freight Car Chart**

(Box Car.) Has every part numbered and named. Price, 25c.

**Anatomy of a Freight Car Chart**

(Goodola Car.) Has every part numbered and named. Price, 25c.

**Traction Power Chart**

Shows the draw bar pull of any locomotive without a single calculation. Price, 50c.

**Anatomy of a Passenger Car Chart**

Has every part numbered and named. Price, 25c.

Send for a special circular describing these books in full. Any of these books sent prepaid on receipt of price.

**AGENTS WANTED**

Write for particulars.

The Norman W. Kenley Publishing Co. 132 Nassau St., New York, U. S. A.

# The Superiority OF RUBEROID ROOFING

Registered U. S. Pat. Off.

For railroad uses is no better demonstrated than by the following letter:

"We have gotten better results from Ruberoid Roofing than any other roofing of this style which we have tried. In fact, where we must contend with coal smoke, we have decided that we cannot afford to use any other kind of composition roofing. B. S. WATHEN, Chief Engineer, "The Texas Pacific Railway Co."

Send for Prices and Samples.

**THE STANDARD PAINT COMPANY**  
100 William St., New York  
CHICAGO, ST. LOUIS, PHILADELPHIA, ATLANTA, BOSTON, KANSAS CITY, NEW ORLEANS.

# Ball's Official R.R. Standard Watches

16 AND 18 SIZE

17 and 21 Ruby  
Jewels,  
Sapphire Pallofs

Ball's Improved  
Safety  
Double Roller



Are without question the finest watches that American talent and skilled labor can produce, and they are giving such universal satisfaction that we have no hesitancy in claiming that they are the best and safest railroad watch on the market. Tests severe and numerous have proven this fact to the most critical

users in all sections of the country, to which thousands of good Railroad and Brotherhood men are ready to certify.

We have an authorized agent in nearly every railroad center. Call on him for information and facts. Write us for descriptive matter.

**The Webb C. Ball Watch Co.**  
Watch Manufacturers  
Ball Building, Cleveland, Ohio, U. S. A.

# Patents.

GEO. P. WHITTLESEY

MCGILL BUILDING WASHINGTON, D. C.  
Terms Reasonable Pamphlet Sent

## Combination Band Rip and Edging Saw.

Our illustration shows a new combination band rip and edging saw. For edging, the table is provided with a traveling chain under the out feeding roll, and is operated by a sprocket chain and gearing from the same shaft that runs the upper-feed rolls. This traveling chain has a vertical adjustment and can be quickly dropped below the surface of the table so as to be out of the way for ripping.

The column of this machine is very heavy and is free from vibration. The distance between the fence and the saw blade admits material up to 24 ins. wide. The rolls may be raised to receive timber 12 ins. thick. The table is of ample size, and has, at the front, a plainly stamped index. Idler rolls are fitted in the table to reduce friction. A cam lever releases, moves and clamps the fence.

The wheels are 42 ins. in diameter, made with spokes and are entirely of iron and steel, the lower one is heavy and has a solid web, which gives it considerable momentum, so that its speed governs that of the upper wheel, preventing it from over-running. The wheel shafts are of steel, especially heavy, running in extra long self-oiling bearings.

The straining device controlling the upper wheel, and the path of the saw blade on the face of the wheels, is a new and very sensitive device. It has a forward, backward and also a side adjustment. It is regulated by an adjustable weight and a compound lever which make it so sensitive that no matter what the vibrations may be, the strain takes up the slack in the blade instantly, adding wonderfully to the perfect working of the machine and the life of the saw blade. The saw guides are the latest improved pattern with sectional hardwood blocks arranged to permit of taking up the slightest wear and perfectly guiding the blade in the plane of the cut.

There are three speeds of feed, 30, 60 and 125 ft. per minute. Faster feeds can be furnished if desired. The feed is very powerful; the driven feeding-in and feeding-out rolls are close together, thus enabling short stock to

be worked. They are adjustable instantly up and down by means of the long lever above, placed conveniently to the operator, or they may be raised from the board, instantly stopping the feed, or lifted quickly out of the way for use as a hand feed rip-saw. All this may be accomplished by a single movement of the long lever. The feeding-out roll bearing is adjustable to take up the slack in the driving chain.

For further information regarding this tool, write direct the manufacturers, J. A. Fay & Egan Co., 445 West

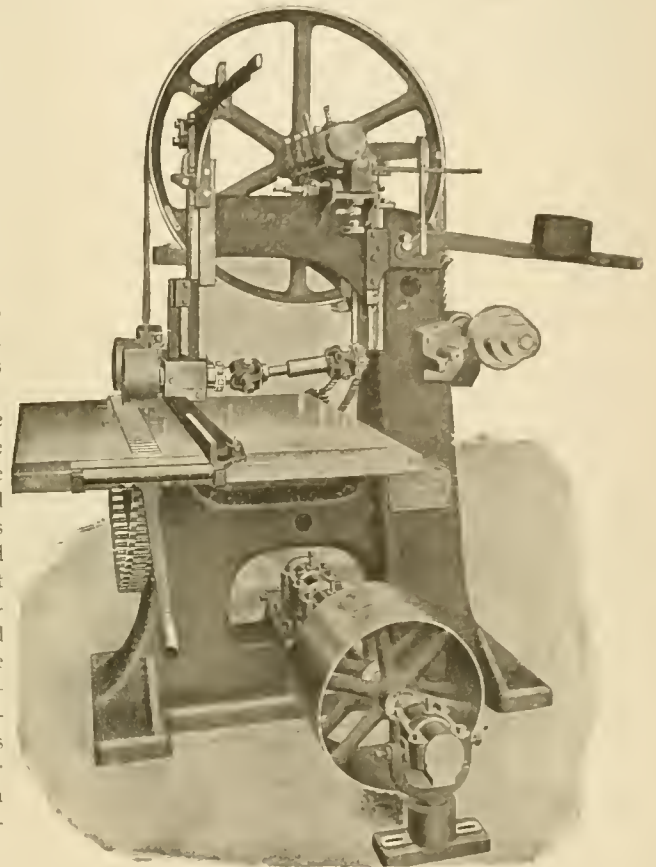

BAND RIP AND EDGING SAW.

Front street, Cincinnati, O., and they will be glad to reply to any enquiry.

Cleanola is the name given by the makers to a composition which is intended to clean, polish, renew and preserve varnished surfaces. It is used on many railroads as a car and locomotive cleaner and is used by palace car companies here and abroad. The cleaner is put up in cans from 6 oz. to gallon sizes and is supplied by the barrel and half barrel as required. The Cleanola Company have offices in the Fulton Building, Pittsburgh, Pa., and they will be happy to answer any inquiries which may be sent to them by those interested.

It seems natural that the people of countries that produce no petroleum should want to use alcohol in their automobiles. Alcohol can be made from anything containing carbon. In

# AN ACCEPTABLE CHRISTMAS PRESENT

ought to be something that will be preserved as a reminder of the giver. There is no article so well adapted for this purpose as a good book. Among books at the present day there is nothing more suitable than the History of the Locomotive Engine, by Angus Sinclair. If you have friends among railroad men upon whom you wish to confer a courtesy, send them this book as a Christmas present. It costs Five dollars, being less than a box of good cigars and does not go up in smoke.

**Angus Sinclair  
Company**  
136 Liberty Street,  
New York, N. Y.

Greece an agitation is going on to overcome the difficulty of expensive gasoline by substituting a cheap form of alcohol distilled from currants, which is a crop chronically suffering from overproduction.

### Hard Work Well Done.

If we may judge from several very outspoken expressions of opinion which have come to our knowledge we would say that the King-Lawson dump cars have been giving some excellent service of a very hard and exacting nature and have stood up to the work without costing much for maintenance. The Lackawanna have been using these cars for the past two years in all classes of gravel work and earth excavation and what is harder still, tunnel rock excavation material has been most successfully handled.

A contracting firm testifies to the fact that these cars stood on the track



KING-LAWSON DUMP CAR.

which had one rail elevated and dumped material to the high side far enough away from the rail to do away with the necessity of rehandling. Another firm of contractors in railway work refer to the fact that the King-Lawson cars dump material quickly and this is important as on a busy road they cannot hold the main line longer than about fifteen minutes and they are pleased with the fact that after the material has been dumped it does not have to be moved or leveled for other trains to pass. The air dumping mechanism worked without giving any trouble.

The kind of work done by these steel dump cars indicates that they were not engaged in any show parade or exhibition game. They were not mollycoddled in any way but were put into hard service where the rapid and expeditious removal of rough material was the only thing thought of by those engaged in the work. The cars did what was expected of them without being followed by an army of repairers and

### International Correspondence Schools Box 805, Scranton, Pa.

Please explain, without further obligation on my part, how I can qualify for a larger salary and advancement to the position before which is marked X.

General Foreman R. R.	R. R. Const'n Eng.
R. R. Shop Foreman	Civil Engineer
R. R. Trav. Engineer	Bridge Engineer
R. R. Trav. Fireman	Chemist
Locomotive Engineer	Mining Engineer
Air-Brake Instructor	Architect
Air-Brake Inspector	Bookkeeper
Air-Brake Repairman	Stenographer
Mechanical Engineer	Ad. Writer
Mechanical Draftsman	French } With
Machine Designer	German } Edison
Electrical Engineer	Spanish } Phonograph

Name \_\_\_\_\_  
Employed by \_\_\_\_\_ R. R.  
Street and No. \_\_\_\_\_  
City \_\_\_\_\_ State \_\_\_\_\_

# Does this Coupon Mean \$20,000 to YOU

According to statistics compiled from the United States Bureau of Labor and other sources the average wage earner—fireman, carpenter, machinist, mason—earns about \$720 a year. His average working life is 40 years and he therefore makes \$28,800 during his life.

The average foreman, superintendent, manager, and executive official—the man whose position has required him to secure a technical training—earns \$1,200 a year and acquires during his life \$48,000.

Then the difference in the life earnings of the untrained wage earner and the technically trained official is in round numbers \$20,000.

This is the value in actual dollars and cents that I. C. S. training has been to thousands of ambitious wage earners. A coupon like that above has been worth \$20,000 to hundreds of these men because by clipping, marking, and mailing this coupon they have made a start to secure, in their own homes, in their spare time, the training that has qualified them for better positions, increased earnings, and greater happiness.

If there is any possibility of such an action meaning \$20,000, \$10,000, or even a paltry \$1,000 to you, don't you think the experiment is at least worth trying? It puts you under no obligation to do this.

Simply mark  
and mail this  
coupon  
NOW



# Tate Flexible Staybolt



Strong  
Effective  
Economical

Flexibility  
Durability  
Simplicity

Holds firebox sheets securely together, and accommodates itself to the unequal expansion of the plates.

## FLANNERY BOLT COMPANY

PITTSBURG, PA., U. S. A.

Suite 308, Frick Bldg.

B. E. D. STAFFORD, - - General Manager  
Write us for Reference Book

took rough and smooth, bitter and sweet as it came and stood the racket in good style. Those interested in knowing more about the performance of the King-Lawson air-operated dump car should communicate with Captain Thomas Lawson, of 17 State street, New York, and give him a chance to hand out a few facts.

### Water Gauge.

Do you know what an Ashcroft Prismatic Water Gauge is? If not, there is an easy way to find out. Drop a post-card to the Ashcroft Manufacturing Co., of 85 Liberty street, New York, and ask for a copy of their folder on the subject. In the meantime we may say that this prismatic gauge is one which, when in use, makes the water look black and the steam space white. This has the effect of showing a very clearly defined line of demarcation between the two and the water level in a boiler is a thing about which there should be no uncertainty and about which no one can afford to take chances. The gauge is flat and broad and the metal part is made of a special bronze composition. The stems are of Tobin bronze and the valve seats are reinforced with special hard bronze and everything else is made of good material. The glass is the striking feature, however, and it is simply a flat piece with a series of parallel V-shaped grooves running up and down in it, and the property of this glass is to so reflect the light that water looks black and steam looks white when seen through it. The gauge is a good thing. You ought to look into it.

### Alundum.

A folder recently issued by the Norton Company of Worcester, Mass., gives a brief account of the invention and use of alundum. This material forms a most useful abrasive and alundum wheels are largely used for grinding in railway repair shops and in other industries. A few words from the folder telling what alundum really is may not be out of place here.

"The process of making alundum consists in taking the oxide of aluminum found in nature and known as the mineral bauxite, purifying and melting it in immense electric furnaces. Upon cooling, the mass solidifies as ingots of alundum. Beautiful crystals are found in the center of these masses, showing nearly all the variety of colors found in the ruby and sapphire, of which alundum is one variety.

"Bauxite, the raw material from which alundum is made, is the purest naturally occurring amorphous oxide of aluminum known. This mineral was originally found at Baux, France, from which it derives its name, but purer forms are now obtainable in the United States.

## Locomotive Blow-Off Plug Valves

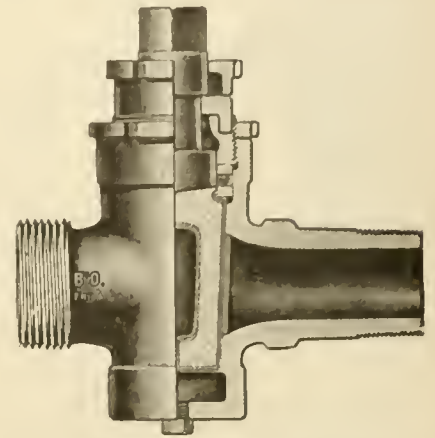

All Brass, extra heavy, with Cased Plug. For 250 lbs. pressure. Made with Draining Plug to prevent freezing.



## LOCOMOTIVE GAUGE COCKS

For High Pressure

Bordo Self-Closing Gauge Cocks, made with renewable Hard Bronze seat and disc. Opened and closed with a quarter turn. Guaranteed Steam tight under the most exacting conditions. Shanks Threaded to specifications for Locomotives.

Seats and discs replaced under pressure.

## Swing-Joints and Pipe Attachment

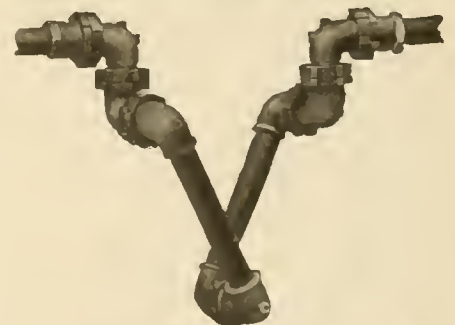

May be applied between Locomotive and Tender. These Swing-Joints are suitable for Steam, Gas, Air, Water or Oil.

Complete Booklet on Application

**L. J. BORDO CO.**  
PHILADELPHIA, PA.



**The  
Twentieth  
Century  
Outfit**

**WHAT DOES IT DO?** It does the work of a lot of men, is on its job all the time—men sometimes fail to reach the shop for days—it costs less than the annual pay of any one of this lot of men. For further information write

**Baker & Carr Mfg. Co.,** 19 Fairview Heights  
Rochester, N. Y.

**FROM HAND CARS TO EXPRESS LOCOMOTIVES.**  
Drawings for all kinds of railroad machinery a specialty.

**SIDNEY C. CARPENTER,** *Draftsman and Designer*  
PLAINVILLE, CONN.

**MICA**  
**CABOOSE LAMP CHIMNEYS**  
Save 50 per cent.

**STORRS MICA CO.,**  
R. R. Dept. Owego, N. Y.

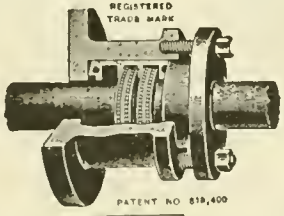
REGISTERED TRADE MARK  
PATENT NO. 819,400

PAT. NO. 482,177	PAT. NO. 654,861
" " 600,899	" " 656,642
" " 634,104	" " 729,888
" " 802,828	" " 775,194
" " 776,148	" " 774,480

**NO MORE BILLS for PACKING**  
No Cutting of Rods  
Less Oil. No friction  
Guaranteed 3 years. 30 Days' Trial  
No Pay unless Satisfactory  
Beware of Imitations. Use the Best  
Manufactured only by

**Holmes Metallic  
Packing Company**  
Wilkes-Barre, Pa.  
Send for Catalogue K

**THE WASHBURN CO.**  
Minneapolis, Minn.  
**Automatic Couplers**  
For Freight, Engine and Passenger Service

"In order to insure rapid and continued cutting so far as sharpness is concerned a peculiar quality is necessary. There must be a fracture which will give a number of sharp-cutting points. This is obtained in alundum.

"Different grades are required for different materials to be ground. Cast iron, steel, brass, glass, bone, leather, wood and other substances demand wheels of special grade to make the grinding operation continuously efficient."

The folder contains an interesting description of this useful abrasive and is worth reading. Write to the Norton Company for a copy.

A recent press dispatch from Jamestown, N. Y., says that a meeting of the employes of the Erie Railroad, representing every branch of the service, has been held in that city to consider the forming of an Erie Employes' Pension Association. The company presented a plan by which they would assist their employes, and this plan was formally accepted by the men. It will be more fully developed early in 1908. The officers representing the men at the meeting were Messrs. J. J. MacNeill, Cleveland, president, and F. J. Jones, Youngstown, secretary.

The New York, New Haven & Hartford Railroad are now running their thirty-five Westinghouse electric locomotives on local trains between the Grand Central Station, New York, and Stamford, Conn. The success of the operations involved has exceeded the expectations of the officials of the railway company and of the manufacturers, and it is understood that a considerable addition to the locomotive equipment is now under consideration. Each locomotive was intended to haul only five-car local trains, but it frequently happens that trains of as many as eight cars are handled with ease by a single locomotive, and on a recent occasion one of these locomotives pulled a broken down steam locomotive with its train into Stamford so that a new engine could be attached, and we have no doubt that a steam locomotive will be happy to return the complement if occasion for it should ever arise.

The fifty-fourth annual meeting of The American Society of Mechanical Engineers will be held in the Engineering Societies Building at 29 West 39th street, New York, December 3-6, 1907. Symposiums on foundry practice, giving the experiences of prominent men in that line of work, have been arranged for. The specific heat of superheated steam will be taken up, and a very im-

**Homestead  
Valves**  
Straightway, Three-way and Four-way,  
and  
**Homestead  
Locking Cocks**  
Are Famous the World Over  
They cost more, but are worth very much more than other makes. You try them and see.



Brass, 1 1/2 in.



Iron Body, Brass Plug, 1 1/2 in.

**HOMESTEAD VALVE MFG. CO**  
WORKS:  
HOMESTEAD, PA.      PITTSBURG, PA.

**American Locomotive  
Sander Company**  
13th & Willow Sts., Philadelphia, Pa.  
Proprietors and Manufacturers  
LEACH, SHERRBURNE, DEAN,      SANDERS  
HOUSTON, "SHE" and CURTIS

**THE ROBERT W. HUNT & CO.**  
Bureau of Inspection, Tests and Consultation,  
1137 THE ROOKERY, CHICAGO.  
66 Broadway, New York.  
Park Building, Pittsburg.  
31 Norfolk House, London, Eng.  
Inspection of Steel Rails, Splice Bars, Railroad Cars, Wheels, Axles, etc. CHEMICAL LABORATORY—Analysis of Ores, Iron, Steel, Oils, Water, etc. PHYSICAL LABORATORY—Test of Metals, Drop and Pulling Test of Couplers, Draw Bars, etc. Efficiency Tests of Boilers, Engines and Locomotives.

# One Year and Eleven Months' SERVICE

WITHOUT REPACKING. ON

## High-Pressure Locomotives

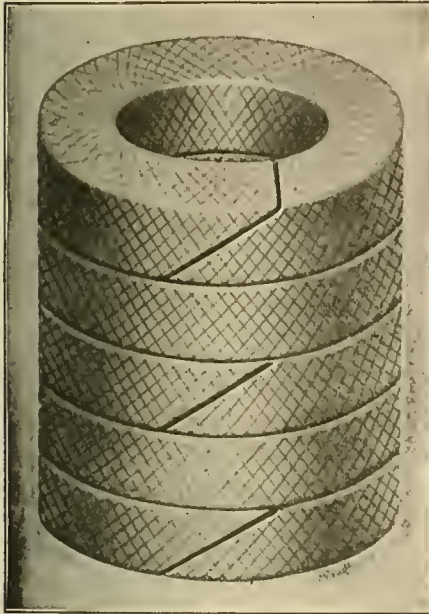

Style 300 TV.

A throttle failure is an absolute impossibility where Crandall's Throttle Valve packing is used.

IT WILL NOT BLOW OUT

## Crandall Packing Co.

FACTORY AND GENERAL OFFICE  
PALMYRA, - - NEW YORK

BRANCHES

New York  
136 Liberty St.

Cleveland  
9 So. Water St.

Chicago

52 West Washington St.

## Directory of Railways of the World

The Universal Directory of Railway Officials, published in London, contains a list of the entire railroads of the world, with physical particulars and names of all officials.

Send Your Order Now

for the 1907 edition.

Price \$4.00 Prepaid

A. FENTON WALKER

Sole Representative for U. S.

143 Liberty St. New York

portant and exhaustive work by a professor of engineering at Cornell University will be presented. The utilization of low grade fuels in gas producers, combustion control in gas engines, tests of producer gas engines, etc., will come before the society. Other topics, such as industrial education, power transmission by friction driving, cylinder port velocities, etc., will be discussed. These subjects have been treated by prominent engineers of Europe and America, professors of our universities, and men eminent in the particular work of which they write. The committee have on hand an interesting excursion and an address in the evening which is expected to be especially enjoyable.

### Testing Track, Not Engine Speed.

In some reports which have recently appeared in the daily press concerning certain tests the Pennsylvania Railroad have been making on the West Jersey and Sea Shore Railroad near Clayton, N. J., it has been stated that the company was racing steam and electric locomotives, with a view to determining the speed capacity of each. The types of electric and steam locomotives which have been used in these experiments were not designed primarily for speed, and any inference based on their performance in this regard would be incorrect. It was not a speed contest, it was a track test.

Experience has indicated that the operation of electric locomotives, owing to their lower centre of gravity, has an effect upon the track entirely different from that due to the action of steam locomotives. In order to ascertain the exact nature and extent of this pressure upon the rails the motive power department of the Pennsylvania have devised the apparatus which is being utilized at Clayton.

A stretch of track about 166 ft. in length has been equipped with rails and cast steel ties, designed and made especially for this purpose. Instead of attaching the rail to the ties by spikes, a special form of block has been substituted which allows a very slight movement of the rail as the engine goes over it; this movement registers the force with which the flanges of the wheels press against the rails. It is expected that a large number of experiments with this apparatus will show what the effect is of either steam or electric locomotives, moving at different speeds over either straight or curved track.

Necessarily to make these tests, the engines must move at different speeds, and at times each attains its maximum speed.

An electric apparatus has been devised to measure the precise amount of time elapsing while the different locomotives pass over this 166 feet of track, in order that in computing the effect upon the track the exact speed attained may be

## THE TANITE CO. seeks the support of Railroaders because:

The man who uses a TANITE wheel will find it safe. Because pay for a TANITE wheel secures the greatest productive capacity. Because TANITE MILLS EMERY is mined in America and appeals to all who earn wages in America. Because TANITE grinding machines are practical.

THE TANITE CO. sells Emery, Solid Emery Wheels, Buffing Lathes, Guide Bar Grinders, Car Brass Grinders, Bench and Column Grinders, Surfacing Machines, Open Side Emery Planers, Saw Gummers, Automatic Planer Knife Grinders, Diamond Tools, Polishing Paste for Brass and Nickel, Emery Wheel Cutters and Dressers.

The Tanite Co. builds special machines for special wants

## THE TANITE CO. STROUDSBURG, PA.

# THE UNION SWITCH & SIGNAL COMPANY

CONSULTING AND MANUFACTURING SIGNAL ENGINEERS

Automatic Block Signals—Electric and Electro-Pneumatic

Interlocking — Electric, Electro-Pneumatic and Mechanical

Electric Train Staff Apparatus

General Offices and Works at SWISSVALE, PA.

DISTRICT OFFICES:

NEW YORK - - 143 Liberty Street

CHICAGO - - - Monadnock Block

ST. LOUIS - - - Frisco Building

## Oliver Lippincott Photographer

20 John Street, New York

Process and Mechanical Prints

Perfect reproduction from Tracings, Black Lines, White Paper, any size, for Specifications and Estimates.

# The Twentieth Century Master Mechanic

Won't use Solid Mandrels.  
Cost too much, take up too much room and don't give satisfaction.

## Nicholson Expanding Mandrels

Take everything from 1 to 7 inch holes. Take up little room—always ready and you can buy four sets for the cost of one of the solid kind.

## Are You Using Them?

Catalogue tells you more about them.

**W. H. Nicholson & Co.**  
Wilkesbarre, Pa.

**STANDARD MECHANICAL BOOKS FOR ROAD AND SHOP MEN BY CHAS. McSHANE.**

## The Locomotive Up to Date

Price, \$2.50

## New York and Westinghouse Air Brakes

Price, \$1.50

## One Thousand Pointers for Machinists and Engineers

Price, \$1.50

All books bound in fine cloth.

AGENTS WANTED everywhere; write for terms and descriptive circulars. Will be sent prepaid to any address upon receipt of price.

**GRIFFIN & WINTERS**  
171 La Salle Street, CHICAGO

known. The steam and electric locomotives, however, go over the track at different times, and there is no element of contest as to speed between the two types. The matter of speed is purely incidental to the main purpose of the tests, which is to enable the company, in planning its electric installations in New York, to design a track so safe as to be absolutely secure against any deformation which might arise from the use of any type of locomotive that may be put in service.

The H. W. Johns-Manville Company, of New York, have recently issued several small folders setting forth the merits of some of their products. The folder called "Pipe Covering Pointers" says:

The insulating properties of any kind of pipe covering depend entirely upon the amount of dead air which it confines. Asbesto-sponge felted covering has high efficiency because it contains an immense number of minute air cells. This is due to two causes, which are the materials employed and the peculiar laminated form of construction. This asbesto-sponge felted covering is made up of laminations of fine paper composed of asbestos paper and particles of finely ground sponge. These materials are naturally of a cellular nature, and being made up like the leaves of a book and additional air spaces are provided between each layer.

Another product is the moulded mica waterproof lamp sockets. They are for use out of doors, for streets, parks, etc., also in mills, tunnels, mines, packing houses and other damp places. They do not break or crack like porcelain, are waterproof and possess the good insulating qualities.

Their folder concerning leak-no states that its peculiar chemical action lies in metallizing and its power of amalgamation. During its metallizing process it expands so that it fills a leak, and as it expands equally with iron and steel. Leak-no is a chemical metallic compound, prepared in powder form and used by mixing with water to a stiff putty. When in this state it is a thoroughly plastic material that will metallize in a few hours and become a part of the casting to which it is applied. When hard it has the same color as cast iron.

### Awards at Jamestown.

The Jury of Awards for the Jamestown Exposition have awarded the Baldwin Locomotive Works of Philadelphia a diploma of a gold medal for the most admirable, effective and artistic installation of their exhibit. The Exposition Company state that they will forward to this firm, in due season, the award diploma, together with a replica in bronze of the medal.

# TOOL STEEL

**Die Blocks  
Steel Forgings**

First Prize awarded at the Louisiana Purchase Exposition, at St. Louis, for our TOOL STEEL when placed in competition with the best makes in England and Germany.

Write for Information and Prices. Specify McInnes Tool Steel when ordering.

**McINNES  
STEEL CO.**  
CORRY, PA.

Agents  
**SOHROCK & SQUIRES,**  
291 Pearl St., New York.  
**ROY MACHINERY CO.,**  
Minneapolis, Minn.

### CONTENTS

*Black Diamond on the Lehigh.....	525
A Holy Terror in Jim Skeevers' Hands...	526
Among the Railroad Men, Jas. Kennedy...	528
*Hydraulic Ram .....	529
*Cutter for Side Rod Holes.....	531
*Potent Pictorial Post Cards.....	532
*General Correspondence .....	533
*Piston Rings Scientifically Turned.....	536
*Curiosities of Locomotive Design.....	537
Installing Block Signals on the U. P.....	539
Book Notices .....	543
Car Ferry on Lake Ontario .....	544
Traveling Engineers' Convention .....	552
Momentum .....	555
*Gasoline Weed Burner on the U. P.....	556
Pooling of Locomotives, D. R. McBain....	559
*Pipe Threading Machine .....	560
*Hold Fast Grease Cup Plug .....	562
*Band, Rip and Edging Saw .....	563
*Hard Work Well Done .....	564
Testing Track, not Engine Speed.....	567

### Locomotives:

*Mallet Compound for Brazil.....	531
*Missouri Pacific 2-8-0.....	555

### Editorials:

Conciliation .....	540
Wasteful Practices .....	540
Adjusting the Deflector .....	540
Small Proportion of Heat Used.....	541
Stealing from Railroads.....	541
American Railway Association.....	542
Mechanical Stokers .....	542
A Theory of Derailment on Curves.....	543
Reasons for Reductions .....	543
Life of Railroad Appliances.....	543

### Departments:

Correspondence School .....	545
Questions Answered .....	547
Air Brake Department .....	549
Patent Office .....	551
Personals .....	557





















CARNEGIE LIBRARY OF PITTSBURGH  
3 1812 04298 5524

