

Experimental facility for the production of reference atmosphere of radioactive gases (Rn, Xe, Kr, and H isotopes)



B. Sabot^{*}, M. Rodrigues, S. Pierre

CEA, LIST, Laboratoire National Henri Becquerel (LNE-LNHB), 91191, Gif-sur-Yvette Cedex, France

ARTICLE INFO

Keywords:

Radioactive gas
Metrology
Radon
Xenon
Tritium
Krypton

ABSTRACT

Radioactive gases are of great interest for environmental measurements and can be distinguished in two categories. The natural radionuclides such as the isotopes of radon (^{222}Rn and ^{220}Rn), and the anthropogenic radionuclides coming from fission products (isotopes of Xe and ^{85}Kr) and activation products (^3H and ^{37}Ar). Gas monitoring in the environment is an important issue for radioprotection and for the Comprehensive Nuclear-Test-Ban Treaty (CTBT), which both require metrological traceability of these gases. For this purpose, two gas chambers, of 42 L and 125 L, have been conceived and built at the LNE-LNHB to produce reference atmospheres of various gas mixtures. These chambers were created in order to provide any radioactive gas atmosphere with a wide range of activity concentrations ($\text{Bq}\cdot\text{m}^{-3}$ to $\text{MBq}\cdot\text{m}^{-3}$). The goal of this setup is to be representative of the different environmental conditions for detector qualification and to perform studies of radioactive gas absorption in materials of interest. As a result, the 2 chambers used in this experimental facility are designed to work from vacuum pressure to atmospheric pressure, with a constant activity concentration for any radioactive gas, and under dry to high humidity conditions. It can also be used in a static mode, in which the activity concentration will follow the radioactive decay of the gas. In this paper, the characterization of the chambers will be discussed. These two chambers are combined with different primary standards established by the LNE-LNHB. As the production of the reference atmosphere depends on the primary standard method, we present the details for each atmosphere production, which require a well-known volume, pressure or a direct activity concentration measurement.

1. Introduction

Many studies and developments have been performed in the last decade in the field of radioactive gases, which can be divided among three applications. The first is the monitoring of radioactive gas isotopes such as ^{133}Xe , ^{135}Xe , $^{131\text{m}}\text{Xe}$, $^{133\text{m}}\text{Xe}$, and also ^{37}Ar , in the environment for the Comprehensive Nuclear-Test-Ban Treaty with different measurement techniques developed by different countries and placed in several places over the world (Le Petit et al., 2015), (Ringbom et al., 2003) (Dubasov et al., 2005) and (Aalseth et al., 2011). The measurement techniques developed to measure activity concentrations of several $\text{mBq}\cdot\text{m}^{-3}$ of these isotopes have proven their efficiencies with recent nuclear test events (Ringbom et al., 2013).

The second application is the monitoring of ^{85}Kr and ^3H in air. These gases are monitored to check nuclear powerplant activity and nuclear waste treatment activity such as at La Hague in France (ORANO, 2019). These facilities are authorized to release certain quantities to the

environment and it is thus necessary to continuously measure them in air. Such monitoring can be also used to detect accidental releases (Igarashi et al., 2014). The typical activity concentrations of ^{85}Kr in air are several $\text{Bq}\cdot\text{m}^{-3}$ up to a $\text{kBq}\cdot\text{m}^{-3}$ in the area near nuclear waste treatment activities. The ^{85}Kr represents more than 99% of noble gases released from such facilities. In the case of ^3H , the monitoring of the concentration in air is more difficult due to the production of tritiated water (HTO) which represents 99% of the concentration in air. A portion of this tritium is produced naturally in the upper atmosphere ($5\cdot 10^{16}$ to $7\cdot 10^{16}$ Bq/year), another portion is produced by nuclear powerplants ($1.1\cdot 10^{13}$ Bq/year up to $6.8\cdot 10^{16}$ Bq/year per reactor), and the remaining comes from nuclear weapons testing (10^{20} Bq for the tests between 1945 and 1963) (Calmon et al., 2010). It is also important to note that interest in gaseous tritium has increased recently due to the development of fusion reactors such as the ITER project, which plans to use a lot of tritium gas.

The third application is related to the radon isotopes ^{222}Rn and

^{*} Corresponding author.

E-mail address: benoit.sabot@cea.fr (B. Sabot).

^{220}Rn . They are present all over the world and are a significant cause of lung cancer in non-smokers, thus a recommended limit for the general public has been set at $100 \text{ Bq}\cdot\text{m}^{-3}$ for ^{222}Rn (World Health Organisation, 2009). In addition, with the pervasiveness of this gas in the environment and at a level of $10 \text{ Bq}\cdot\text{m}^{-3}$ outside up to about $100 \text{ kBq}\cdot\text{m}^{-3}$ inside a room, it is well known to disturb other gas measurements. Many recent works have shown that ^{220}Rn must also be considered (McLaughlin, 2010; Hosoda et al., 2017), and recent developments have been performed to provide some traceability or to prove its impact on ^{222}Rn measurement (Sabot et al., 2016a,b; Röttger et al., 2014; Kobayashi et al., 2005; He et al., 2017; Michielsen and Bondiguel, 2015).

The LNE-LNHB started a project in 2018 to develop measurement techniques to assure measurement traceability for gasses of interest for the CTBT. During the same year, the LNE-LNHB was involved in the development of radon and thoron low-level activity concentration atmospheres in the framework of the MetroRADON Euramet EMPIR joint research project. With additional interest in ^3H and ^{85}Kr calibration techniques, it was decided to produce reference gas atmospheres at the LNE-LNHB for a pure isotope or for mixed gasses. The purpose of the chamber in the future will be for new detector qualification but also to test secondary and primary standards that will be developed at the LNE-LNHB. Also, these chambers will be used to test the behaviour of certain materials that absorb noble gases.

In this work we will describe the technical specifications of this new setup and how each radioactive gas atmosphere is produced. This will include the link between the chambers and each gas primary standard along with the appropriate uncertainty budgets. These uncertainty budgets are for the atmosphere production but are not for calibration uncertainties and the procedure.

2. Setup configuration and technical properties

The experimental setup is presented in Fig. 1, and the corresponding block diagram is represented in Fig. 2. Even if the entire setup is a complex instrument, it can be handled easily by a straightforward logical interface. It is entirely automated using microcontrollers and a computer. As a result, a huge amount of data and measurements can be stored during weeks of exposures and analysed automatically.

The setup is divided in several parts to perform a maximum

flexibility. Each part of the setup has a corresponding letter a, b, c and d on Fig. 2 and are subsequently described.

- The first part is for air and radioactive gas mixing: it uses dry compressed air provided by our research centre (CEA-Saclay) which is then filtered and dried again by an air dryer membrane. The lowest value of relative humidity measured is 0.9 (20) % RH (relative humidity), which is below the limit of the measurement device (Sensirion sensor SHT31). Oil and aerosols are removed using pressurised charcoal and HEPA filters. This air can be mixed with gas from different lines connected in parallel, with high precision mass flow regulator with a range from 0 to 20 L/min with a relative standard uncertainty of 0.18% between 0 and 4 L/min and 0.9% between 4 and 20 L/min; the reproducibility of the measurement is 0.2%. As a result, we can perform very stable flow over many days of measurements. One of the lines use a 1.2 m stainless steel tubing which has inside a fluorinated ion exchange resin tube (Nafion®). The resin tube is designed for the deionized water circulation and around the resin dry air can circulate in the stainless steel pipe. This ion exchange membrane allows the transfer of water under gas phase in the air. It produces a high and stable humidity atmosphere which was measured at 97 (2) % RH. Using a mixing ratio with the two flowmeters (one for dry air and one for high humidity), atmospheres from 0.9% up to 97% RH are possible. The other lines go into different ^{226}Ra or ^{228}Th sources to produce ^{222}Rn or ^{220}Rn atmosphere. The last one, with a mass flowmeter, is for controlling the flow from pressurised bottles with standard concentration activities of ^3H , ^{85}Kr (Makepeace et al., 1994), ^{133}Xe (Picolo et al., 1998), ^{127}Xe (Rodrigues et al., 2014), $^{131\text{m}}\text{Xe}$, and ^{37}Ar (Williams et al., 2016).
- Volume measurement: this part is used for the measurement of the free volume inside each chamber, which is described in section 3. It is composed of high precision pressure sensors (CPG 2500 and CPR2550, 0 to 200 000 hPa with a relative standard uncertainty of 0.01%) and thermometers (CTH7000 and CTR3000: 50 to 200 °C with a relative standard uncertainty of 0.02%); N_2 from pressurised bottle is used for gas filling during volume measurement.

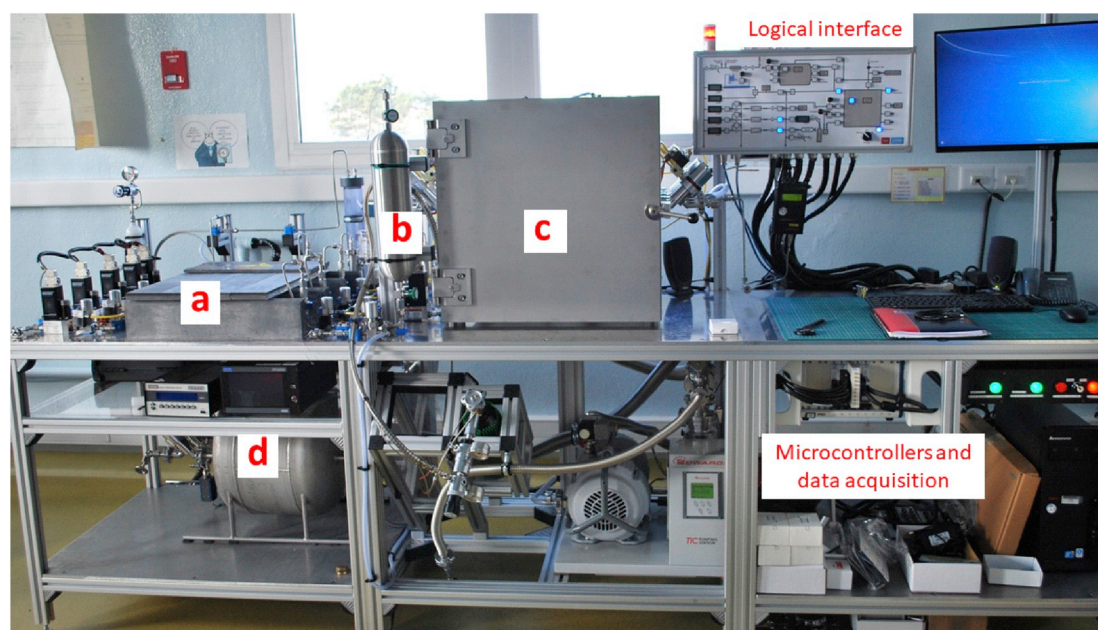

Fig. 1. Photograph of the entire setup showing the two chambers; (a) air and radioactive gases production, (b) certified reference volume (V_{ref}), (c) 125 L chamber equipped with a large door to place devices inside for non-contaminating gases, (d) 42 L chamber used for contaminating gases.

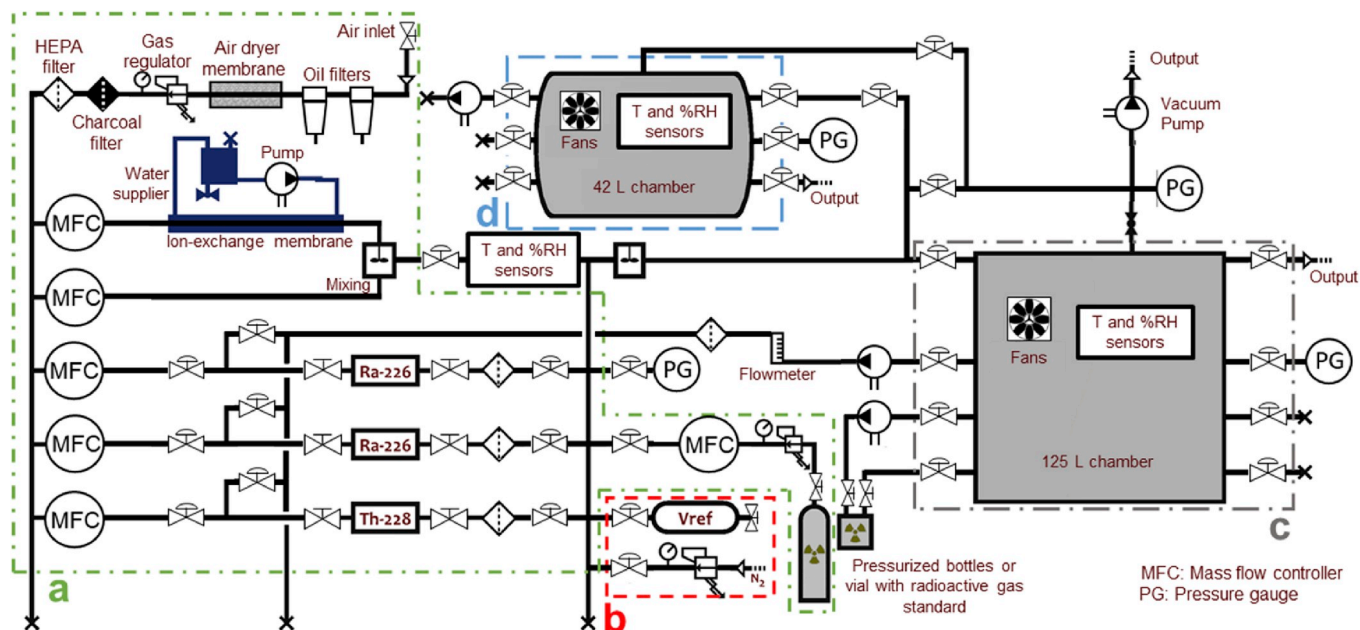

Fig. 2. Diagram of the setup; (a) Part is corresponding to the different pipes, filters, dryer, humidifier, radioactive gases production or standardized bottles connected together in order to produce clean and radioactive air. (b) Part corresponding to the N_2 injection and certified volume for free volume measurement. (c) Part corresponding to the 125 L chamber with fans, sensors and possible connections. (d) Part corresponding to the 42 L chamber with fans sensors and possible connections.

- (c) The “big chamber”: its free volume is 125 L defined by a cube of 50 cm length. This chamber possesses a door able to pass devices, materials or track detectors inside (cf. Fig. 3). Two fans can be moved and connected directly to the gas inlet inside the chamber to ensure a fast gas mixing and avoid heterogeneity. The fan’s holders are a 3D printed part of crystalline polyethylene terephthalate (PETG). Although plastics are generally known as gas absorbers, this one was tested using the techniques described by (Pressyanov et al., 2011) and does not absorb noble gas.
- (d) The “small chamber”: its free volume is about 42 L with 2 small fans inside; this volume does not possess a door as the first one. Its main purpose is to be used for to hold contaminant gas, for example, 3H with humidity in air. It is possible to connect a detector, with a pump circulating the gas in the chamber in order to

test them. This chamber has also a second purpose: it will be used to do higher dilutions using its connection with the big chamber.

On both chambers it is possible to connect devices or a small gas bottle that will be connected to a small and tight pump for a gas loop. In both chambers, the pressure range is from 10^{-5} hPa up to 2000 hPa. In this range of pressure, the two chambers volume do not change; the wall thickness of the 125 L chamber are 1 cm (walls) and 2 cm (door) of stainless steel, and the shape (pressurized bottle shape) of the 42 L chamber with 5 mm stainless steel guarantee the volume at this pressure range. The materials inside are some pieces of PVC from cables and oil free fans (also made of PVC). This material is used as radon barrier in buildings, for example. However, to be prudent, we use as little excess material as possible in the chamber. This volume of plastic represents 0.2% of the total free volume for the 125 L chamber and 0.1% of the free volume for the 42 L chamber. Sometimes some PTFE pipes are used inside the chamber, but this polymer has a very low permeability to the noble gases and humidity. All pipes used for the outside circuit connecting the two chambers or to the sensors are made of stainless steel. The valves and connections are sealed with metal seals made of aluminium or silver.

Two tests were performed on the full setup in order to check for leaks: one with helium and an ASM Graph D from Adixen® that does not show any sign of leakage, and another with over pressure (1200 hPa) in the circuit and the chambers with the measurement of the ratio of pressure to temperature (P/T) over 1 week. The result of this measurement has shown a standard deviation below 0.1%. This P/T measurement is the typical test performed before any noble gas exposure.

In these chambers is it also possible to connect a ^{226}Ra or a ^{228}Th source in a circulation loop on in order to reach the maximum activity concentration. The full setup can be used with the control panel, but it is also connected to microcontrollers in order to set automatic experiments and to save measurements of every parameter (temperature, humidity, pressure, flow rate, etc.).

The entire system is placed in an under-pressurised room of LNHB laboratory (minus 50 hPa compared to external pressure) on the second floor of the building with constant ventilation. As a result, there is a very low background of radon, which was measured in the laboratory to be

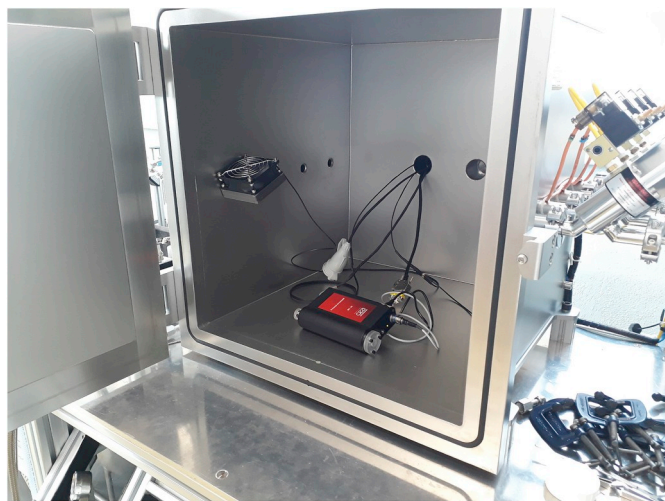

Fig. 3. Picture of the inside of the 125 L chamber with an experimental device placed inside for qualification and tests under radioactive atmosphere. One of the two movable fan is visible on the picture, power supply and data acquisition cables are available in the chamber.

an average of $5 \text{ Bq}\cdot\text{m}^{-3}$ with a standard deviation of $6 \text{ Bq}\cdot\text{m}^{-3}$ over 1 month of measurement with a pulsed ion chamber. Only two incidents of elevated levels ($40 \text{ Bq}\cdot\text{m}^{-3}$) were observed during that time.

The same average amount of $5 \text{ Bq}\cdot\text{m}^{-3}$ with a lower standard deviation of $4 \text{ Bq}\cdot\text{m}^{-3}$ was measured inside the closed chamber, at the same time as the previous measurement with the same kind of pulsed ion chamber and using a circulation of the compressed air coming also from CEA-Saclay (without the charcoal filter at the inlet of the setup). However, we have not observed the same elevated levels of $40 \text{ Bq}\cdot\text{m}^{-3}$, which is quite understandable due to the fact we were using air coming from a research centre supplier and not from the laboratory room. These results are near the detection limit of such devices. This can also explain the large standard deviation on the measurements of the activity concentration. The other isotopes of noble gases, ^{220}Rn , ^{85}Kr , ^3H and Xe isotopes, were not detected. If it is necessary to handle radio-pure air, without any contamination of ^{222}Rn during measurement, we would use pressurised bottle of compressed air stored during at least 1 month for the decay of ^{222}Rn . Thus, the activity concentration of radon in air becomes totally negligible compared to a standard atmosphere produced in our setup at more than several hundreds of $\text{Bq}\cdot\text{m}^{-3}$.

In the next part of this paper, we will present examples of measurements and calculations for the 125 L chamber; the same technique are used for the 42 L chamber but this chamber is dedicated for contaminating gases such as ^3H .

3. Primary standard of radioactive gases

3.1. ^{222}Rn (Radon)

The ^{222}Rn standard developed at the LNE-LNHB (Picolo, 1996) is based on an activity measurement, under vacuum, of a frozen radon source using the defined solid angle method. The radon is produced by a ^{226}Ra source under vacuum (10^{-6} hPa) and then frozen on a “cold finger” to produce a 6 mm diameter source. This source is then measured by the defined solid angle method using a silicon detector (PIPS®). Once measured, the radon is then stored into a stainless-steel vial made in LNHB and under vacuum using a nitrogen bath. In order to make sure everything is transferred in the metal vial, a second measurement is performed.

This measurement technique has been upgraded (Sabot et al., 2016) and we are now able to produce radon standards stored into the metal vial at a pressure of 10^{-6} hPa with a relative standard uncertainty of 0.3% from 100 Bq to 4 MBq. This standard can be transported into the vial and connected to any other system. This primary measurement system has been used in the international comparison CCRI(II)-K2. Rn-222 with consistent results.

3.2. Xe, Kr and H

For other gases, ^{127}Xe , ^{133}Xe , $^{131\text{m}}\text{Xe}$, ^3H and ^{85}Kr , the gas activities are measured at the LNE-LNHB by a primary standard technique using a compensated length triple counter. This primary standard was set in 1993 at the LNE-LNHB (Lansiart et al., 1993) and is still used at the laboratory; a recent publication describes the technique and associated uncertainties (Unterweger et al., 2015).

The measurement is based on the standardization of a pressurised bottle which is a mix of pure N_2 and the radioactive gas. A sample of this bottle is taken with a precise pressure, temperature and volume measurement. This sample is then mixed with the counting gas (propane) and measured by the triple counter. These three counters are cylinders having the same geometry, except their length. The technique consists of calculating the difference of counting rate between each counter in order to remove the effects in the edge of the cylinders, i.e., where the electric field is not perfect. Using these results and knowing precisely the volume of the set-up, we can measure precisely the activity concentration of the sample and provide the activity concentration of the sampled

pressurised bottle.

This primary standard allows the measurement of a pressurised bottle of radioactive gas with an activity concentration (A_V) from 2.5 up to $15\,000 \text{ Bq}\cdot\text{cm}^{-3}$ at standard conditions of temperature and pressure (STP) with a relative standard uncertainty of 0.6% for ^{133}Xe , ^3H and ^{85}Kr and 1% for ^{127}Xe , $^{131\text{m}}\text{Xe}$ and $^{133\text{m}}\text{Xe}$. This primary measurement system has been used in the international comparison BIPM.RI(II)-K1 for Xe-133 (Ratel and Michotte, 2004), CCRI(II)-K2 for ^{85}Kr and more recently in a comparison for ^3H -in-water.

3.3. ^{220}Rn (thoron)

In the case of ^{220}Rn , we are not able to use the method developed in § 3.a. due to its short half-life of 55.8 s (Bé et al., 2016). As a result, we decided to develop a reference measurement system in order to directly measure the activity concentration in the chamber (Sabot, 2015). This measurement system is based on a reference volume with an alpha detector which is able to directly measure thoron and its decay products at atmospheric pressure. In order to improve the spectrum quality of the thoron progenies, an electric field is applied to catch the decay products on the detector surface. The developed system is a portable device which can be used to measure reference thoron atmospheres from $100 \text{ Bq}\cdot\text{m}^{-3}$ with 2% relative standard deviation up to $1 \text{ MBq}\cdot\text{m}^{-3}$ with 1% relative standard deviation.

This device can also be used to measure ^{222}Rn activity concentration with the same kind of uncertainty. However, in the case of mixed ^{222}Rn and ^{220}Rn , the relative standard uncertainty is twice as high due to the complex analysis of the measured spectrum.

4. Production of radioactive gases atmosphere in static mode

4.1. Ideal gas

In a closed volume with stable pressure and temperature, the mole calculations of the gas follow the ideal gas equation (1)

$$PV = nRT. \quad (1)$$

with P the pressure, V the volume, R gas constant, T the temperature and n the number of moles of gas. This equation will govern all the following calculation to measure volume or activity concentration.

4.2. Volume measurement

Two important values must be known for gas measurement with this technique: one is the activity itself, as measured by primary standards (cf. § 3), and the second is the volume of the chamber. With a big volume and a lot of pipes and valves, it is difficult to measure properly a volume from the dimensions of the different parts; therefore, we use gas and pressure equilibrium for the measurement.

As shown in Fig. 4, a small volume (a stainless steel bottle) calibrated by the LNE (French national metrology institute) with a certified volume $V_{\text{ref}} = 2223.6 (1) \text{ cm}^3$ was used. This bottle is pressurised with N_2 to a measured pressure, P_{ref} (maximum on this bottle is 20 MPa) and a measured temperature, T_{ref} . The rest of the pipes and volumes are under vacuum. First, the valve, V_{ref} , is opened to allow the N_2 to move throughout the pipe volume, and P_1 , and T_1 are measured to deduce V_1 with equation (2):

$$\frac{P_{\text{ref}} V_{\text{ref}}}{T_{\text{ref}}} = \frac{P_1 V_1}{T_1}. \quad (2)$$

The step is reproduced to measure $V_2 = V_1 + V_{\text{ch}}$ by measuring T_2 and P_2 where V_{ch} is the volume of the internal free volume of the gas chamber, tubes and standard vial connected (Cf. Fig. 4). Using the same equation as previously, the working volume of the chamber can be deduced by equation (3):

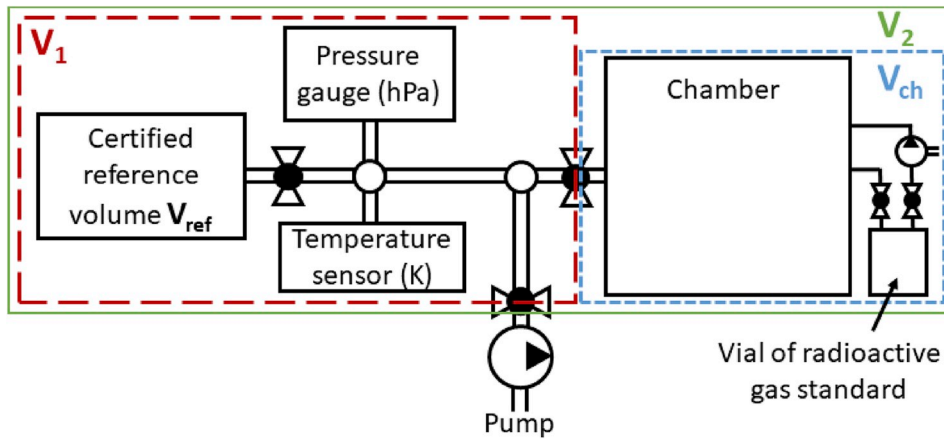

Fig. 4. Scheme details for volume measurements. The small dash (blue) box represents the free volume of the chamber with vial and pump connected on it (V_{ch}). The large dash (red) box represents the free volume of the certified bottle (V_{ref}), the pipes and measurement devices, which are used to measure free volume (V_1). The full box (green) represents the total free volume of the system. (For interpretation of the references to colour in this figure legend, the reader is referred to the Web version of this article.)

$$V_{ch} = \left(\frac{T_2}{P_2} - \frac{T_1}{P_1} \right) \frac{P_{ref} V_{ref}}{T_{ref}}, \quad (3)$$

with its corresponding uncertainty calculated using equation (4):

$$\begin{aligned} u^2(V_{ch}) = & \left(\frac{V_{ref}}{T_{ref}} \left(\frac{T_2}{P_2} - \frac{T_1}{P_1} \right) \right)^2 \cdot u^2(P_{ref}) + \left(-\frac{P_{ref} V_{ref}}{T_{ref}^2} \left(\frac{T_2}{P_2} - \frac{T_1}{P_1} \right) \right)^2 \\ & \cdot u^2(T_{ref}) + \left(\frac{P_{ref}}{T_{ref}} \left(\frac{T_2}{P_2} - \frac{T_1}{P_1} \right) \right)^2 \cdot u^2(V_{ref}) + \left(-\frac{P_{ref} V_{ref}}{T_{ref} P_1} \right)^2 \\ & \cdot u^2(T_1) + \left(\frac{P_{ref} V_{ref} T_1}{T_{ref} P_1^2} \right)^2 \cdot u^2(P_1) + \left(-\frac{P_{ref} V_{ref} T_2}{T_{ref} P_2^2} \right)^2 \cdot u^2(P_2) \\ & + \left(\frac{P_{ref} V_{ref}}{T_{ref} P_2} \right)^2 \cdot u^2(T_2), \end{aligned} \quad (4)$$

where $u(x)$ is the standard uncertainty of the quantity x . One example of volume measurements is presented in Table 1; this measurement was performed during the qualification of one small radon measurement system developed by the CEA and placed inside the big chamber (cf. Fig. 3). The free volume obtained was 124.93 (19) L, which represents a standard uncertainty of 0.16%; this free volume includes a small vial (used for gas standard transportation) connected to the chamber. By analysing the contribution of each measurement, the final pressure, P_2 , can be deduced as the most sensitive one. In order to have improved accuracy on the measurement of P_2 , the pressure inside V_{ref} should be the highest, i.e., 20 MPa. Nevertheless, more precautions must be taken due to temperature changes with gas expansion. With such pressures, we can estimate by calculation that the relative standard uncertainty on the volume could be as low as 0.05%.

This technique is very precise to measure free volume when vacuum can be maintained in the chamber with the device or the material placed inside the chamber. If the device or the material cannot be placed under vacuum, the procedure is modified so that the pressure is measured before opening the volume (i.e., near standard atmospheric pressure)

Table 1

Measurement of the free volume in the big chamber during the test of one detector developed by the CEA in order to test the detection efficiency of Rn-222 for the device.

Quantity	Measured value with its uncertainty	Relative contribution (%)
P_{ref}	1987.65 (5) hPa	0.02
V_{ref}	2223.6 (1) cm ³	0.09
T_{ref}	294.19 (10) K	4.78
P_1	1854.57 (5) hPa	0.01
T_1	294.32 (10) K	0.01
P_2	34.68 (5) hPa	90.07
T_2	293.9 (10) K	5.02
V_{ch}	124.93 (19) 10 ³ cm ³	

and then the valve of the reference volume is opened. As a result, an additional pressure measurement is made and the uncertainty is twice as high.

4.3. Production of ²²²Rn atmosphere

This atmosphere is prepared directly after the volume measurement with a primary standard presented in § 3.a. The vial, which is under vacuum with a primary standard of radon, is connected to the chamber and the radon gas is mixed with clean air using a pump (as indicated on Figs. 4 and 5). Once the vial is opened, the mixing with air is very fast due to a high flow fan at 33 m³ h⁻¹ which is placed directly at the entrance of the gas, and a pump with a flow rate of 11 L min⁻¹ inside the vial that contains the standard and which has a volume of 100 mL. As a result, we can calculate the produced activity concentration at the measured pressure and temperature and at time t using equation (5):

$$A_v(^{222}\text{Rn}) = \frac{A(^{222}\text{Rn}) e^{-\left(\lambda_{222\text{Rn}}(t-t_{ref})\right)}}{V_{ch}}, \quad (5)$$

where V_{ch} is the combined volume of the sample chamber and the vial previously measured, $A(^{222}\text{Rn})$ is the activity of the radon standard at the reference time (t_{ref}), $\lambda_{222\text{Rn}} = 2.09838 (44) 10^{-6} \text{ s}^{-1}$ (Bé et al., 2016) is the decay constant of radon. With this technique, we can produce radon atmospheres with a relative standard uncertainty of 0.34% on the activity concentration typical range is several kBq·m⁻³ that is allowed to decay to reach a value below 100 Bq·m⁻³. This well-characterised atmosphere can then be used to test the detectors that were placed inside the chamber before the free volume measurement. The uncertainty is of only the activity concentration; additional uncertainty components need to be considered if the device placed inside the chamber were to be calibrated. However, we can use this reference value to compare with the results of a device and to test reproducibility of the measurement by following the decay of the radioactive gas.

4.4. Production of Xe, Kr and H atmosphere

With this system there are two possible ways to introduce atmospheres with Xe, Kr, and H isotopes:

- One is to connect a pressurised bottle of standardized radioactive gas (cf. § 3.b) to the chamber and to measure pressure and temperature to deduce directly the activity of gas inserted in the chamber. If necessary, air (or any other gas) can be added to reach a specific pressure. This can be used for high activity concentrations up to several MBq·m⁻³, which done in this current work.
- Place a sample from a pressurised bottle of standardized radioactive gas into a small metal vial (the same vial as used for radon) and

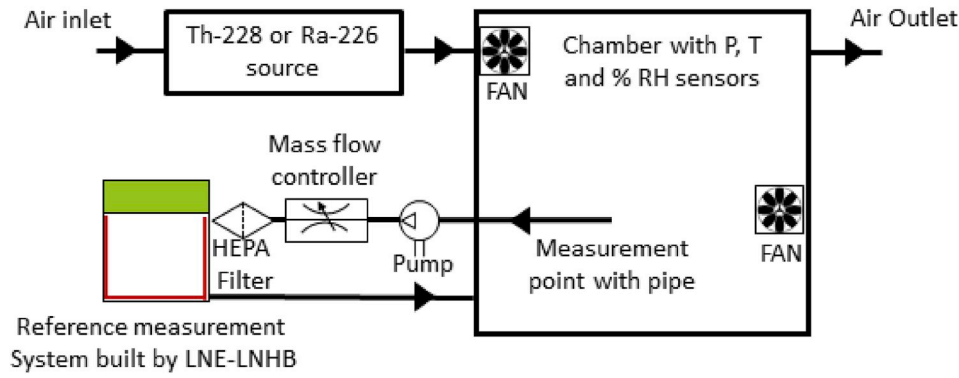

Fig. 5. Measurement of the activity concentration of ^{220}Rn and ^{222}Rn atmospheres produce in the chamber by ^{228}Th and ^{226}Ra using an external reference measurement device developed by the LNHB (Sabot et al., 2016) and connected to the chamber.

proceed the same way as presented in the previous § 3.a. This technique can be used for lower activity concentrations, as tested in the laboratory.

The volume of the stainless-steel vial used for sampling has been measured at the LNHB with the technique presented in § 3.b. ($V_{\text{vial}} = 105.84(31)\text{cm}^{-3}$) during a previous experiment for the international comparison CCRI(II)-K2.Rn-222. This vial is connected to the bottle and the pressure P_{vial} (hPa) and temperature T_{vial} (K) are measured; the activity inside the vial is calculated as:

$$A_{\text{vial}} = \frac{P_{\text{vial}} V_{\text{vial}} A_v}{1013.25} \frac{273.15}{T_{\text{vial}}} \quad (6)$$

The metal vial can then be connected to the chamber, air (or other gas) mixed in at a desired pressure and temperature, and the activity concentration inside the chamber calculated using equation (7)

$$A_v(\text{Chamber}) = \frac{A_{\text{vial}} e^{-(\lambda_{\text{gas}}(t-t_{\text{ref}}))}}{V_{\text{ch}}} \quad (7)$$

where λ_{gas} is the decay constant of the radioactive gas, t_{ref} is the reference date of the standard, and t is the measurement time. Table 2 presents examples of the calculation for the lowest activity concentration that is possible to produce with this setup: $209.1 \text{ Bq}\cdot\text{m}^{-3}$ with a relative standard uncertainty of 1.2%. At this concentration, the uncertainty is mainly due to the contribution from the measurement of P_{vial} . In the case of a higher activity concentration, for example $8.36 \text{ kBq}\cdot\text{m}^{-3}$ with 0.7% of standard uncertainty, the main uncertainty contribution is due to the primary standard.

If a lower concentration is of interest, a second dilution which will increase the uncertainty according to pressure and volume measurements but will allow measurement down to several $\text{mBq}\cdot\text{m}^{-3}$ with 1.6% of relative standard uncertainty from two successive dilutions can be applied.

Table 2

Calculation of activity concentration of ^{85}Kr inside the chamber for a primary standard measured with the triple proportional counter using equations (7) and (8) for decay correction of 1 day between reference date and measurement time.

Quantity	Low activity concentration		Typical activity concentration	
	Measured value with its uncertainty	Relative contribution (%)	Measured value with its uncertainty	Relative contribution (%)
P_{vial}	5.00 (5) hPa	68.07	50.00 (5) hPa	2.08
V_{vial}	105.84 (31) cm^3	5.84	105.84 (31) cm^3	17.90
A_v	50.0 (3) $\text{Bq}\cdot\text{cm}^{-3}$	24.47	200.0 (12) $\text{Bq}\cdot\text{cm}^{-3}$	75.05
T_{vial}	293.15 (10) K	$\ll 0.01$	293.15 (10) K	$\ll 0.01$
V_{ch}	124.93 (19) 10^3 cm^3	1.62	124.93 (19) 10^3 cm^3	4.97
$\lambda_{\text{Kr-85}}$	$2.0429 (44) 10^{-9} \text{ s}^{-1}$	$\ll 0.01$	$2.0429 (44) 10^{-9} \text{ s}^{-1}$	$\ll 0.01$
$t - t_{\text{ref}}$	86400 (1) s	$\ll 0.01$	86400 (1) s	$\ll 0.01$
$A_v(\text{Chamber})$	209.1 (25) $\text{Bq}\cdot\text{m}^{-3}$		8.36 (6) $\text{kBq}\cdot\text{m}^{-3}$	

4.5. Exposure

In the case of the measurement of radioactive gas absorption into a material (i.e., polymers) or the evaluation of detectors which perform integrated measurement (i.e., track detectors), we can calculate the exposure as the integrated activity $I_A(^A\text{X})$ concentration over an exposure time t_{exp} (Picolo et al., 2000):

$$I_A(^A\text{X}) = A(^A\text{X}) \frac{1 - e^{-(\lambda_{A_X} t_{\text{exp}})}}{V_{\text{ch}} \lambda_{A_X}} \quad (8)$$

where λ_{A_X} is the decay constant of the radioactive gas and $A(^A\text{X})$ is the activity of the standard injected into the volume. Typical times of exposure for such experiments is long: at least one week for a material and one month for track detectors.

The introduction speed of the radioactive gas and mixing is just a few minutes (pump mixing with standard vial is $11 \text{ L}\cdot\text{min}^{-1}$ and the speed of the 2 fans inside the chamber is $33 \text{ m}^3 \text{ h}^{-1}$). So, compared to the half-life of these radionuclides (from days to many years) and to the long-time of exposure, the time of introduction and mixing is negligible. In the case of ^{222}Rn , the background of $6 \text{ Bq}\cdot\text{m}^{-3}$ is also negligible with the standard activity introduced of approximately $10 \text{ kBq}\cdot\text{m}^{-3}$. However, for lower activity concentrations, a one-month old pressurised bottle is used to make sure that no contamination of radon comes from the air. Relative uncertainty on the integrated activity concentration for such exposures can be expected to be lower than 1.5% depending on the isotope.

5. Production of atmospheres with a stable activity concentration

One of the main uses of a stable activity concentration atmosphere is for the measurement of ^{220}Rn ; with its short half-life, the only way to produce this kind of atmosphere is to use emanation sources. This technique can also be used to produce a stable atmosphere of ^{222}Rn and

requires solid source of ^{228}Th to produce ^{220}Rn and solid source of ^{226}Ra to produce ^{222}Rn . These solid sources are enclosed in small volumes, with a flow rate inside. On this setup, one of the ^{226}Ra sources is a commercial source from Pylon® of about 3.6 MBq that can be used between 0 and 10 L min⁻¹ of flow rate with dry and clean air. Unfortunately with this source, the activity is not certified and the absolute emanation rate is unknown but is estimated at 80 (20) %. Nevertheless, a stable emanation has been measured over 3 days with a relative standard deviation of 1.4% on the concentration of radon at 998 (1) hPa, 25 (5) °C with a very stable flow rate of dry air inside the source at 1.000 (1) L min⁻¹. This source cannot be used with humid air (Pylon's limitation).

Two other sources used on the system are built by the LNE-LNHB in the framework of the MetroRADON EURAMET project. These two sources have certified activities of ^{226}Ra 1059 (8) Bq with 54 (2) % emanation rate and ^{228}Th , 840 (16) Bq with 98 (3) % emanation rate. These sources are used to produce low activity concentrations; a stable emanation measured over 3 days had a relative standard deviation of 0.7% for temperatures between 20 °C and 34 °C and relative humidity between 3% and 64%.

These 3 sources are used to produce relatively stable activity concentrations of radon isotopes that is then certified by a constant measurement method developed by the LNE-LNHB and connected to the chamber (Sabot, 2015) (cf. §3.c). The concentration of ^{222}Rn and ^{220}Rn can be measured directly with the device at a measurement point in the chamber as shown in Fig. 5. A Teflon pipe is placed inside the chamber in order to measure the activity concentration as near as possible to the device to be tested and that is inside the chamber. In this case the best estimate relative standard uncertainty for both radon isotopes atmospheres is 2% using a measurement device from LNE-LNHB for an activity concentration of 100 Bq·m⁻³ up to 10 MBq·m⁻³ (Sabot et al., 2016). However, for an activity concentration of 100 Bq·m⁻³, the measurement requires one week of continuous monitoring to obtain enough statistics and low uncertainties. Compared to § 3, this technique avoids any volume measurements and can be used to compare results from a commercial device to a reference measured value. Also, it is our recommended technique for measuring our reference atmosphere of ^{220}Rn rather than calculating the activity concentration in the chamber using emanation rate and ^{228}Th (Cf. § 6).

For any other radioactive gases such as ^3H , Xe and Kr isotopes, the pressurised bottle of standardized radioactive gas (cf §3.b) can be connected directly to a mass flow meter and regulator (see Fig. 2), and also mixed with dry or humid air. The flowmeter used here can regulate flow rates from 0 to 20 L/min with a relative standard deviation of 0.1%. A mixing ratio between each line can be calculated to estimate the stable activity concentration in the chamber. In contrast to radon isotopes, these kinds of atmospheres cannot yet be directly measured with a reference device at the LNE-LNHB. This is the main purpose of this newly developed setup: to produce reference radioactive gas atmospheres in order to provide the possibility for the LNE-LNHB to test the new devices developed for the measurement of ^3H , Xe, Kr and Ar isotopes in air (cf. § 7).

6. Homogeneity problems, the case of ^{220}Rn

While the noble gases have no special behaviour in air and do not interact chemically, some, such as ^{220}Rn at 55.8 s, have a very short half-life, creating homogeneity problems in a chamber. If many devices, such as track detectors, are placed in a chamber, it is then necessary to take into account this short half-life and define the inhomogeneity. As previously shown, ^{220}Rn is used to measure the activity concentration at a certain point in the volume. These results must be combined with a homogeneity map distribution, which can be either experimental - a new technique is presented in the ICRM 2019 conference by K. Mitev et al. using silica aerogel and liquid scintillation counting - or by Multiphysics simulations using the flow and diluted species calculations as described here (Sabot, 2015). The Navier Stokes equations are solved and

combined in the software with the mass equilibrium equation (9):

$$\frac{\delta C_{Rn}}{\delta t} + v_f \nabla C_{Rn} = \nabla \cdot (D_{Rn} \nabla C_{Rn}) + \tau_R, \quad (9)$$

C_{Rn} is the radon concentration (it depends on the radon concentration given at the volume inlet), D_{Rn} is the diffusion coefficient of radon in air ($1.1 \cdot 10^{-5} \text{ m}^2 \text{ s}^{-1}$ at 1013 hPa and 293.15 K), v_f is the speed vector calculated by the Navier Stokes equation, and τ_R is the "reaction" of radon in air. As radon is a noble gas, the only reaction that can be observed is due to its decay, which can be described with equation (10):

$$\tau_R = -\lambda_{220_{Rn}} C_{Rn}, \quad (10)$$

$\lambda_{220_{Rn}}$ is the ^{220}Rn decay constant: $12.42 (7) 10^{-3} \text{ s}^{-1}$ (Bé et al., 2016).

Using these equations, it is possible to perform Multiphysics simulations (Comsol Inc, 2014). An example of the result calculated in the big chamber at the LNE-LNHB is presented in Fig. 6. This simulation shows that the distribution equilibrium is obtained after 400 s of circulation of thoron in the chamber. The inlet flow rate is 10 L min⁻¹ and one fan is activated with a flow rate of 33 m³ h⁻¹ and a diameter of 80 mm. In this figure we can see that, after a few seconds, the thoron is not perfectly homogenous in the volume; in addition, the inlet result provides an inhomogeneity of at least 10%. This can be a good tool to reduce homogeneity problems and try to optimise fan or device positions; however it is time consuming to perform such a simulation (10 h of computer time for this one). Nevertheless, if the measurement is to be compared with another device, it would be better to measure the activity concentration directly at the position of the device measurement inlet, with the thoron reference measurement system as described in § 4, thereby avoiding any homogeneity problem. This technique must be adapted depending on the device to test and in this case, uncertainty can change a lot because it will depend on the environment and how the device is working (pump cycle, diffusion, track detector, material ...)

7. Conclusions and discussions

The LNHB has designed and fabricated a setup which possesses two chambers with free volumes of 42 L and 125 L, respectively, to produce reference atmospheres with parameters under a various range of conditions: air from 0 to 100% RH, pressure from vacuum to 2 bars, and temperature from 18 to 60 °C. A wide range of activity concentrations can be produced for any radioactive gas from several Bq·m⁻³ up to several MBq·m⁻³. Therefore, it will now be possible to compare results from detectors which measure any radioactive gases with a reference value. For the future detector calibrations, the procedure will be assessed especially considering the results of the MetroRADON

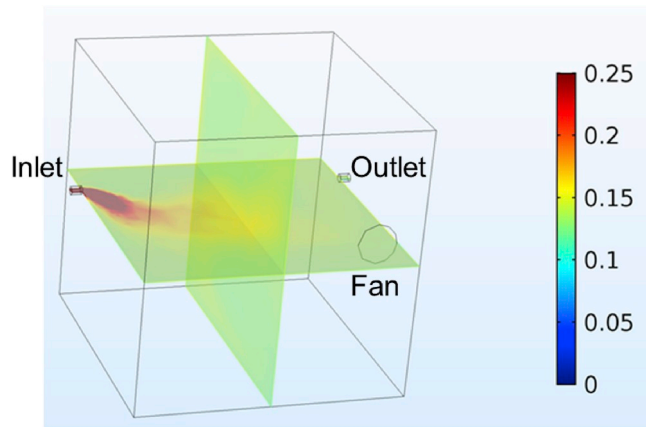

Fig. 6. Results of thoron distribution simulations with maximum concentration normalized to one in the 125 L chamber with one fan activated inlet flow rate of 1 L min⁻¹ and 400 s of circulation.

European project. In addition, this setup provides low activity concentrations of ^{222}Rn and ^{220}Rn (between $100\text{ Bq}\cdot\text{m}^{-3}$ up to $1\text{ kBq}\cdot\text{m}^{-3}$) and will be used to quantify the emanation rates of ^{226}Ra and ^{228}Th , objectives of the MetroRADON European project.

This setup will also be used as an instrument to characterise new materials, to develop new detectors for radioactive gas measurements such as porous scintillator materials that we already started to test at LNHB (Odzimek et al., 2018) or polycarbonate makrofol (Mitev et al., 2018). There is currently no reference measurement techniques in our laboratory for low activity concentrations of Xe, Kr and Ar isotopes, and these chambers will be used to test new measurement systems developed in the laboratory during the next years.

In the future, other functionalities will be added. One, to increase the temperature range of the setup to reach $-20\text{ }^\circ\text{C}$ using a cooling and insulation system, will allow the laboratory to study diffusion lengths and partitions coefficients of noble gas in plastics, which are temperature dependent (Mitev et al., 2018). The second addition envisaged is to use an aerosol generator to provide references measurement for radon decay daughters, which is of great interest for the Airborne Pollutants and Containment Department at the IRSN in France.

Declaration of competing interest

The authors declare that they have no known competing financial interests or personal relationships that could have appeared to influence the work reported in this paper.

Acknowledgements

This work was entirely funded by the French national metrology institute: Laboratoire National de Métrologie et d'Essais (LNE), the authors thank them for providing all the funds which were required to build the setup.

This work is supported by the European Metrology Programme for Innovation and Research (EMPIR), JRP-Contract 16ENV10 MetroRADON (www.euramet.org). The EMPIR initiative is co-funded by the European Union's Horizon 2020 research and innovation program and the EMPIR Participating States.

References

- Aalseth, C.E., Day, A.R., Haas, D.A., Hoppe, E.W., Hyronimus, B.J., Keillor, M.E., Mace, E.K., Orrell, J.L., Seifert, A., Woods, V.T., 2011. Measurement of ^{37}Ar to support technology for on-site inspection under the comprehensive nuclear-test-BanTreaty. Nucl. Instrum. Methods Phys. Res. A652, 58–61. <https://doi.org/10.1016/j.nima.2010.09.135>.
- Bé, M.-M., Chisté, V., Dulieu, C., Kellett, M.A., Mougeot, X., Arinc, A., Chechev, V.P., Kuzmenko, N.K., Kibédi, T., Luca, A., Nichols, A.L., 2016. Monographie BIPM-5 : Table of Radionuclides. Bureau International des Poids et Mesures. ISBN 978-92-822-2264-5. http://www.bipm.org/utis/common/pdf/monographieRI/Monographie_BIPM-5_Tables_Vol8.pdf.
- Calmon, P., Garmier-Laplace, J., Colle, C., Le Dizes-Maurel, S., Adam-Guillermin, C., Bailly du Bois, P., Cossonnet, C., Gurriaran, R., Loyer, J., Picolo, J.L., Renaud, P., Beaugelin-Seiller, K., Boust, D., Paquet, F., Stefano, L., 2010. Radionuclide fact sheet tritium and the environment. IRSN report. https://www.irsn.fr/EN/Research/publications-documentation/radionuclides-sheets/environment/Documents/Tritium_UK.pdf.
- Comsol Inc, 2014. Characterizing the Flow and Choosing the Right Interface, COMSOL Multiphysics, Modeling Guide Version 4.3b.
- Dubasov, Yu S., Popov, Yu S., Prelovskii, V., Donets, A.Yu, Kazarinov, N.M., Popov, V., Mishurinskii, V.V., Dubasov, V. Yu, Rykov, Yu M., Skirda, N.V., 2005. The ARIX automatic facility for measuring concentrations of radioactive xenon isotopes in the atmosphere. Instrum. Exp. Tech. 48, 373–379. <https://doi.org/10.1007/s10786-005-0065-3>.
- He, Z., Xiao, D., Lv, L., Zhou, Q., Wu, X., Shan, J., 2017. Stable control of thoron progeny concentration in a thoron chamber for calibration of active sampling monitors. Radiat. Meas. 102, 27–33. <https://doi.org/10.1016/j.radmeas.2017.02.013>.
- Hosoda, M., Kudo, H., Iwaoka, K., Yamada, R., Suzuki, T., Tamakuma, Y., Tokonami, S., 2017. Characteristic of thoron (^{220}Rn) in environment. Appl. Radiat. Isot. 120, 7–10. <https://doi.org/10.1016/j.apradiso.2016.11.014>.
- Igarashi, Y., Aoyama, M., Nemoto, K., Hirose, K., Miyao, T., Fushimi, K., Suzuki, M., Yasui, S., Asai, Y., Aoki, I., Fujii, K., Yamamoto, S., Sartorius, H., Weiss, W., 2001. ^{85}Kr measurement system for continuous monitoring at the Meteorological Research Institute, Japan. J. Environ. Monit. 3, 688–696. <https://doi.org/10.1039/B105067M>.
- Kobayashi, Y., Tokonami, S., Takahashi, H., Zhuo, W., Yonehara, H., 2005. Practicality of the thoron calibration chamber system at NIRS. Int. Congr. Ser. 1276, 281–282. <https://doi.org/10.1016/j.ics.2004.09.052>.
- Lansart, A., Dhilly, G., Picolo, J.L., 1993. Mesure absolue de l'activité volumique d'un gaz radioactif émetteur beta au moyen de compteurs proportionnels. Note Technique LPRI/93/010.
- Le Petit, G., Cagniant, A., Gross, P., Douysset, G., Topin, S., Fontaine, J.P., Taffary, T., Moulin, C., 2015. Spalax™ new generation: a sensitive and selective noble gas system for nuclear explosion monitoring. Appl. Radiat. Isot. 103, 102–114. <https://doi.org/10.1016/j.apradiso.2015.05.019>.
- Makepeace, J., Clark, F.E., Picolo, J.L., Coursol, N., Günther, E., Unterweger, M.P., 1994. Intercomparison of internal proportional gas counting. Nucl. Instrum. Methods A 339, 343. [https://doi.org/10.1016/0168-9002\(94\)91829-5](https://doi.org/10.1016/0168-9002(94)91829-5).
- McLaughlin, J., 2010. An overview of thoron and its progeny in the indoor environment. Radiat. Prot. Dosim. 141, 316–321. <https://doi.org/10.1093/rpd/ncq234>.
- Michielsen, N., Bondiguel, S., 2015. The influence of thoron on instruments measuring radon activity concentration. Radiat. Prot. Dosim. 167, 289–292. <https://doi.org/10.1093/rpd/ncv264>.
- Mitev, K., Cassette, P., Tartès, I., Georgiev, S., Dimitrova, I., Pressyanov, D., 2018. Diffusion lengths and partition coefficients of $^{131\text{m}}\text{Xe}$ and ^{85}Kr in Makrofol N and Makrofol DE polycarbonates. Appl. Radiat. Isot. 134, 269–274. <https://doi.org/10.1016/j.apradiso.2017.07.023>.
- Odzimek, M., Chaput, F., Dujardin, C., Lerouge, F., Cassette, P., Sitarz, M., Parola, S., 2018. Design and application of high optical quality YAG:Ce nanocrystal-loaded silica aerogels. ACS Appl. Mater. Interfaces 10, 32304–32312.
- ORANO, 2019. La Hague facilities for recycling used nuclear fuel. www.orano.group/en/.
- Picolo, J.L., 1996. Absolute measurement of radon 222 activity. Nuclear Instruments and Methods in Physics, Nucl. Instrum. Methods Phys. Res. A 369, 452–457. [https://doi.org/10.1016/S0168-9002\(96\)80029-5](https://doi.org/10.1016/S0168-9002(96)80029-5).
- Picolo, J.L., Pressyanov, D., Blanchis, P., Barbier, M., Michielsen, N., Grassin, D., Voisin, V., Turek, K., 2000. A radon 222 traceability chain from primary standard to field detectors. Appl. Radiat. Isot. 52, 427–434. [https://doi.org/10.1016/S0969-8043\(99\)00190-6](https://doi.org/10.1016/S0969-8043(99)00190-6).
- Picolo, J.L., Seralta, S., Dulieu, C., Day, F.E., Ratel, G., 1998. International comparison of activity measurements of ^{133}Xe . Appl. Radiat. Isot. 49, 1429–1435. [https://doi.org/10.1016/S0969-8043\(97\)10087-2](https://doi.org/10.1016/S0969-8043(97)10087-2).
- Pressyanov, D., Mitev, K., Dimitrova, I., Georgiev, S., 2011. Solubility of krypton, xenon and radon in polycarbonates. Application for measurement of their radioactive isotopes. Nucl. Instrum. Methods Phys. Res. 629, 323–328. <https://doi.org/10.1016/j.nima.2010.11.112>.
- Ratel, G., Michotte, K., 2004. BIPM comparison BIPM.RI(II)-KI.Xe-133 of activity measurements of the radionuclide ^{133}Xe . Metrologia 41 (Tech. Supplement).
- Ringbom, A., Axelsson, A., Aldener, M., Auer, M., Bowyer, T.W., Fritioff, T., Hoffman, I., Khrestalev, K., Nikkinen, M., Popov, V., Popov, Y., Ungar, K., Wotawa, G., 2013. Radioxenon detections in the CTBT international monitoring system likely related to the announced nuclear test in North Korea on February 12, 2013. J. Environ. Radioact. 128, 47–63. <https://doi.org/10.1016/j.jenvrad.2013.10.027>.
- Ringbom, A., Larson, T., Axelsson, A., Elmgren, K., Johansson, C., 2003. Sauna – a system for automatic sampling, processing, and analysis of radioactive xenon. Nucl. Instrum. Methods Phys. Res. A508, 542–553. [https://doi.org/10.1016/S0168-9002\(03\)01657-7](https://doi.org/10.1016/S0168-9002(03)01657-7).
- Rodrigues, M., Lépy, M.-C., Cassette, P., Mougeot, X., Bé, M.M., 2014. Standardization of xenon-127 and measurements of photon emission intensities. Appl. Radiat. Isot. 87, 342–347. <https://doi.org/10.1016/j.apradiso.2013.11.066>.
- Röttger, A., Honig, A., Linzmaier, D., 2014. Calibration of commercial radon and thoron monitors at stable activity concentrations. Appl. Radiat. Isot. 87, 44–47. <https://doi.org/10.1016/j.apradiso.2013.11.111>.
- Sabot, B., 2015. Calibration of Thoron (^{220}Rn) Activity Concentration Monitors. PhD thesis. NNT: 2015SACL122, pp. 97–100. <http://www.theses.fr/2015SACL122>.
- Sabot, B., Pierre, S., Cassette, P., 2016. An absolute radon 222 activity measurement system at LNE-LNHB. Appl. Radiat. Isot. 118, 167–174. <https://doi.org/10.1016/j.apradiso.2016.09.009>.
- Sabot, B., Pierre, S., Michielsen, N., Bondiguel, S., Cassette, P., 2016. A new thoron atmosphere reference measurement system. Appl. Radiat. Isot. 109, 205–209. <https://doi.org/10.1016/j.apradiso.2015.11.055>.
- Unterweger, M., Johansson, L., Karam, L., Rodrigues, M., Yunoki, A., 2015. Uncertainties in internal gas counting. Metrologia 52, S156–S164. <https://iopscience.iop.org/article/10.1088/0026-1394/52/3/S156/pdf>.
- Williams, R.M., Aalseth, C.E., Bowyer, T.W., Day, A.R., Fuller, E.S., Haas, D.A., Hayes, J.C., Hoppe, E.W., Humble, P.H., Keillor, M.E., LaFerriere, B.D., Mace, E.K., McIntyre, J.I., Miley, H.S., Myers, A.W., Orrell, J.L., Overman, C.T., Panisko, M.E., Seifert, A., 2016. Development of a low-level ^{37}Ar calibration standard. Appl. Radiat. Isot. 109, 430–434. <https://doi.org/10.1016/j.apradiso.2015.12.027>.
- World Health Organisation, 2009. WHO Handbook on Indoor Radon, a Public Health Perspective. ISBN 978 92 4 154767 3.