



A TREATISE  
ON  
MECHANICS,  
APPLIED TO  
THE ARTS;  
INCLUDING  
STATICS AND HYDROSTATICS.

BY THE  
REV. H. MOSELEY, M.A., F.R.S.,  
ONE OF HER MAJESTY'S INSPECTORS OF SCHOOLS;  
LATE PROFESSOR OF NATURAL PHILOSOPHY AND ASTRONOMY, KING'S COLLEGE, LONDON  
AUTHOR OF LECTURES ON ASTRONOMY, &c.

FO622  
PUBLISHED UNDER THE DIRECTION OF  
THE COMMITTEE OF GENERAL LITERATURE AND EDUCATION,  
APPOINTED BY THE SOCIETY FOR PROMOTING  
CHRISTIAN KNOWLEDGE.

THE THIRD EDITION.

LONDON:  
JOHN W. PARKER, WEST STRAND.

M.DCCC.XLVII.



# CONTENTS.

	PAGE
PREFACE . . . . .	9
INTRODUCTION . . . . .	11

## STATICS.

ART.		
1	Definition of Force . . . . .	27
2	Its Direction . . . . .	27
3	Its effect the same wherever applied in the Line of its Direction . . . . .	27
4	The Equilibrium of Forces . . . . .	27
5	The Equality of Forces . . . . .	27
8, 9	The Unit of Force . . . . .	28
10	The Measure of Force . . . . .	28
14	Representation of Forces, in quantity and direction, by Lines . . . . .	28
17	The Parallelogram of Forces . . . . .	30
19	Resultant and Component Forces . . . . .	32
20	The Resolution and Composition of Forces . . . . .	32
21, 22	The Equilibrium of Three Forces acting upon a Solid Mass . . . . .	33
23	Illustrations of the Parallelogram of Forces . . . . .	34
32	The Equilibrium of <i>any number</i> of Forces applied to a Point . . . . .	40
33	The Polygon of Forces . . . . .	41
34	Illustration of the Polygon of Forces . . . . .	41
35	On the Equilibrium of a number of Forces applied to different Points in a Body, but acting all in the same Plane . . . . .	42
36	The Equality of Moments . . . . .	44
44	The Equality of Areas . . . . .	46
47	The Equilibrium of Parallel Forces . . . . .	48
49	If these preserve always their <i>Parallelism</i> in all positions of the body to which they are applied, their Resultant passes always through the <i>same point</i> in it . . . . .	48
51	The Centre of Gravity . . . . .	48
54	Experimental Method of determining it . . . . .	50
55, 57	Illustrations of the Centre of Gravity . . . . .	51
70	Resistance of a Surface not exclusively in a Direction perpendi- cular to that Surface.—Friction.—Limiting Angle of Resist- ance.—Illustrations . . . . .	59
78	Table of Coefficients of Friction . . . . .	63

79	The Inclined Plane.—The Equilibrium of a Mass placed upon an Inclined Plane, and not supported otherwise than by the Resistance of the Plane . . . . .	64
80	Of a Mass partly supported by another Force acting in any direction upon it . . . . .	65
81	Best Direction of this Force so that it may be upon the point of giving Motion to the Mass upwards . . . . .	65
83	Equilibrium of a Cylinder on an Inclined Plane.—Independent of Friction.—The Carriage Wheel . . . . .	66
86	The Moveable Inclined Plane.—Circumstances under which it will be upon the point of sliding upon a Mass which is pressed against it by given forces . . . . .	67
87	The Wedge . . . . .	68
88	Its Angle must not exceed the Limiting Angle of Resistance . . . . .	69
89	Circumstances under which the Wedge cannot be started by any pressure of the Mass into which it is driven on its sides . . . . .	69
90	Examples of the use of the Wedge . . . . .	70
95	The Lever.—Conditions of its Equilibrium . . . . .	73
96	Reaction of its Fulcrum . . . . .	74
97	Applications of the Lever . . . . .	75
99	Effect of the Weight of the Lever . . . . .	77
100	The Roman Statera . . . . .	78
101	The Steelyard . . . . .	79
102	The Danish Balance . . . . .	79
103	The Common Balance . . . . .	80
104	The Balance used for determining the Standard Bushel . . . . .	82
105	Mr. Robinson's Balance . . . . .	85
106	The Bent Lever Balance . . . . .	87
107	On Compound Levers . . . . .	87
108	The Weighing Machine . . . . .	88
109	The Fulcra of Levers . . . . .	89
110	The Axis of a Lever . . . . .	89
111	The Carriage Wheel . . . . .	90
112	Irregularity in the action of a Force applied to the Extremity of a Lever whose direction passes always through the same point.—Method of remedying it . . . . .	91
113	The Wheel and Axle . . . . .	92
115	Modification of the Wheel and Axle, by which its power may be increased without limit . . . . .	94
117	The Windlass . . . . .	95
118	The Capstan . . . . .	95
119	Tread Wheels . . . . .	96
120	Tread Wheels worked by Horses . . . . .	96
122	The Fusee . . . . .	97

# CONTENTS.

ART.		PAGE
123	System of Cog Wheels a Modification of the Compound Lever . . . . .	98
125	Conditions of the Equilibrium of a System of Cog Wheels . . . . .	99
126	Friction got rid of by diminishing the Size of the Teeth . . . . .	101
128	The Crank . . . . .	102
130	The Eccentric . . . . .	104
131	The Stanhope-Press Lever . . . . .	104
132	The Camb . . . . .	105
133	The Theory of the Screw . . . . .	106
135	The Clamp.—The Winch.—The Micrometer Screw . . . . .	108
138	Hunter's Screw.—The Endless Screw . . . . .	108
140	The Conical Screw . . . . .	110
141	On Flexibility . . . . .	110
142	On Tension.—On the Friction of a Cord . . . . .	111
143	On the Pulley . . . . .	113
144	The Single Fixed Pulley . . . . .	113
148	The Single Moveable Pulley . . . . .	116
149	The Spanish Barton . . . . .	116
151	The First System of Pulleys . . . . .	117
152	The Second System of Pulleys . . . . .	118
153	Combinations of the Two Systems . . . . .	119
157	Smeaton's Pulley . . . . .	121
158	White's Pulley . . . . .	122
159	The Conditions of a Rigid System necessary to the Equilibrium of a System of Variable Form, but not sufficient . . . . .	123
163	The Suspended Polygon of Rods . . . . .	125
165	The Catenary . . . . .	126
170	The Upright Polygon of Rods . . . . .	129
174	On Framing of Rods, or Netting of Cords . . . . .	130
178	On Wooden Bridges . . . . .	132
180	On Wooden Arches . . . . .	133
182	Equilibrium of Solid Bodies in Contact . . . . .	134
185	The Arch . . . . .	136
186	The Line of Pressure . . . . .	137
190	The Points of Rupture . . . . .	139
192	The Fall of the Arch . . . . .	140
193	The Settlement of the Arch . . . . .	141
194	The Groin and Dome . . . . .	142
196	The History of the Arch . . . . .	143
198	Elasticity . . . . .	147
200	Method of ascertaining the law of Elasticity, by Torsion . . . . .	147
202	Experiment proving the existence and law of Elasticity in Lead . . . . .	149
204	Ductility . . . . .	150
205	Permanent Alteration of Internal Structure . . . . .	150
208	Extent to which the property of Ductility may be developed . . . . .	152

ART.	PAGE
209 On the Measure of Elasticity.—The Modulus of Elasticity . . . . .	153
210 On <i>direct</i> Compression or Extension ; the Disturbing Force must be applied through the Centre of Gravity of the Section . . . . .	154
211 On <i>oblique</i> Compression or Extension . . . . .	155
212 The Neutral Axis and Neutral Surface . . . . .	156
219 On the Stability of Masses whose Bases are Plane Surfaces . . . . .	162
220 On the Stability where the Bases are Curved Surfaces . . . . .	163
221 When the Surface on which the Base rests is a Curved Surface . . . . .	163
222 On Surfaces of Unrest . . . . .	164
227 On the Principle of Virtual Velocities . . . . .	167
234 Difficulty of Determining Mechanically the Amount of any Statical Resistance . . . . .	174
235 Theory of Resistances where there is only One Resisting Point . . . . .	175
236 Where there are Two Resisting Points . . . . .	176
237 Where there are Three Resisting Points . . . . .	176
239 Principle of Least Resistance . . . . .	178

## HYDROSTATICS.

242 Definition of a Fluid . . . . .	181
244 Equal Distribution of Fluid Pressure . . . . .	182
246 Hydrostatic Press . . . . .	184
248 The Pressure of a Fluid upon a Solid is Perpendicular to its Surface . . . . .	187
249 On the Equilibrium of a Heavy Fluid . . . . .	187
262 The Oblique Pressure of a Heavy Fluid . . . . .	197
265 The Forms of Embankments and Dams . . . . .	199
267 Centre of Pressure . . . . .	199
268 Whole Amount of Pressure on any given Surface . . . . .	200
271 Composition and Resolution of the Pressure of a Heavy Fluid . . . . .	204
272 The Horizontal Pressures upon a Body immersed in a Fluid, destroy one another . . . . .	205
273 Amount of Horizontal Pressure . . . . .	205
278 Effect produced by removing a Portion of the sides of a vessel containing Fluid . . . . .	208
280 Barker's Mill . . . . .	209
281 The Motion of Rockets . . . . .	210
282 The Weight of a Floating Body equals the Weight of the Fluid it displaces . . . . .	213
283 Its Centre of Gravity and that of the Part Immersed are in the same Vertical . . . . .	214
289 Equilibrium of a Triangular Prism . . . . .	217
290 Equilibrium of a Pyramid . . . . .	219

## CONTENTS.

vii

ART.	PAGE
291 Stability of Floating Bodies; Stable, Unstable, and Mixed Equilibrium . . . . .	219
295 Remarkable Analogy between the Conditions of the Equilibrium of a Floating Body, and those of a Body supported on a Smooth Plane . . . . .	223
296 Specific Gravity.—The unit of <i>Specific Gravity</i> . . . . .	225
300 General <i>Rule</i> for determining the Specific Gravities of Bodies . . . . .	228
301 Method of finding the Specific Gravities of Solid Bodies . . . . .	228
302 The Hydrostatic Balance <sup>1</sup> . . . . .	229
303 Methods of determining the Specific Gravities of Fluids . . . . .	232
304 The Hydrometer . . . . .	232
305 Sikes' Hydrometer . . . . .	232
306 The Areometer . . . . .	235
307 Fahrenheit's Hydrometer . . . . .	235
308 Nicholson's Hydrometer.—Table of Specific Gravities . . . . .	236

## PNEUMATICS.

310 Atmospheric Pressure . . . . .	243
311 Reasons why we are not conscious of the Pressure of the Atmosphere upon our Bodies . . . . .	245
313 The Ascent of Bodies in the Atmosphere . . . . .	250
315 Torricelli.—The Barometer . . . . .	253
318 Variations of the Barometer . . . . .	257
320 Amount of the Pressure of the Atmosphere upon the Human Body . . . . .	259
322 The Diagonal Barometer . . . . .	259
323 The Wheel Barometer . . . . .	260
324 The Siphon . . . . .	262
326 Remarks of the Elasticity of the Air . . . . .	264
327 Elasticity of the Air proved by Experiment . . . . .	264
329 Elasticity proportional to Density . . . . .	267
330 The Condenser . . . . .	267
331 The Gauge . . . . .	269
332 The Air Gun . . . . .	269
333 The Exhausting Syringe . . . . .	270
336 The Air Pump . . . . .	273
337 Experiments with the Air Pump . . . . .	276
341 Suction Pump . . . . .	277
342 Lifting Pump . . . . .	278
343 Forcing Pump . . . . .	279
345 Fire Engine . . . . .	281



## APPENDIX.

	PAGE
Propositions containing the Mathematical Demonstration of the Parallelogram of Forces—the Equality of Moments, and the Theory of Parallel Forces . . . . .	253
Propositions 1 to 10 . . . . .	284
On the Direction of the Resistance of a Surface (Note on Art. 72) .	295
The Inclined Plane (Note on Art. 80) . . . . .	296
Theory of the Wedge Demonstrated . . . . .	298
The Balance (Note on Art. 103) . . . . .	300
On the Friction of an Axle (Note on Art. 110) . . . . .	301
On the Conditions of the Equilibrium of Toothed Wheels, taking into account the Friction of the Teeth (Note on Art. 125) . . . .	303
Notes on Art. 182 and 270 . . . . .	305
Note on Art. 295 . . . . .	306

## P R E F A C E.

THE following work contains treatises on the sciences of Statics and Hydrostatics, comprising the whole theory of EQUILIBRIUM. It was intended as the first volume of a *course* of Natural Philosophy, for the use of those who have no knowledge of Mathematics, or who have made but little progress in their mathematical reading.

The *Theoretical* principles of Statics are comprised in the FIRST THREE CHAPTERS of the work; the remaining chapters contain little more than a practical application of these principles.

It is impossible to arrange the parts of a demonstrative science in the order of their difficulty; these first chapters will probably be found to present more difficulties to the student than any other portion of the work. A thorough knowledge of the elementary principles discussed in them, is, nevertheless, a *necessary* introduction to the more practical parts of the science of Mechanics.

Into every practical question of equilibrium, there enters the consideration of *weight*; the mass held in equilibrium, whatever other forces may be applied to it, being necessarily subject to the action of the force of Gravity.

A discussion of the influence of the weight acting in every portion of the mass of a body, upon the conditions of its equilibrium; and of the properties of its centre of gravity through which this weight may be supposed, in every position of the body, to act; constitutes, therefore, the subject of the next, or Fourth Chapter of the work.

There is scarcely any case of equilibrium, among the forces composing which, there do not enter two or more resistances of the *surfaces of bodies in contact*. The question of the resistances of the surfaces of bodies, constitutes, therefore, the subject of the Fifth Chapter. The method of treating it is altogether *new*.

It is shown, that force applied to the surface of one body by the intervention of the surface of another, is destroyed, however great it may be, provided its direction lie *within* a certain right cone; having its vertex at the point of contact, and its axis perpendicular to the touching surfaces: and that it is *not* destroyed, however small it may be, provided its direction lie *without* that cone.

It is by means of this property, that allowance is made for what is usually termed, friction—which is in reality, no other than the difference of the case of the resistance of a surface, as it actually obtains in nature, from the *hypothetical* case of resistance only in the direction of a normal: which hypothetical case, introduced in the infancy of the science, and intended to facilitate its first deductions, has been most unaccountably retained as a principle of equilibrium.

The nature and properties of the forces from whence the equilibrium of material bodies commonly results, having been thus ascer-

tained, the next EIGHT CHAPTERS present the application of these to the Inclined Plane, the Wedge, the Lever, the Wheel and Axle, the Screw, and the Pulley; usually termed the Mechanical Powers.

Chapters Fourteen and Fifteen contain the theory of the equilibrium of systems of variable form. It is shown, that the conditions of the equilibrium of a rigid system are *necessary* to the equilibrium of the same system, when made to admit of variation in its form, but *not sufficient*. And from this principle are deduced certain conditions of the equilibrium of polygons and frames of rods and cords, of the catenary, and finally, the conditions of the equilibrium of bodies in contact, including the Arch.

Chapter Sixteen contains a Discussion, of Dr. Young's theory of the strength of materials, and a table of moduli of elasticity and extension. In Chapter Eighteen, will be found Lagrange's celebrated Demonstration of the principle of Virtual Velocities, which it has been attempted to bring within the comprehension of ordinary readers; and Chapter Nineteen, which contains the theory of Resistances and a demonstration of the new principle of Least Resistance, completes the theory of Statics.

The theory of Hydrostatics or the Equilibrium of Fluid Bodies, presents the extreme case of the equilibrium of a system of variable form. Any portion of such a fluid mass in equilibrium, is therefore subject to the same conditions, as though it were a solid; together with such other conditions as result from its fluidity. It is on this principle, that the whole theory of Hydrostatics is built.

In the First Chapter is discussed the principle of the equal distribution of fluid pressure; in the Second, the conditions of the equilibrium of a heavy fluid; in the Third, the oblique pressure of a heavy fluid, the forms of embankments, the centre of pressure, &c.; the Fourth Chapter treats of the conditions of the equilibrium of floating bodies; the Fifth, of specific gravity, and the instruments used for determining it: and the last, treats of the Science of Pneumatics, or the Equilibrium of Elastic Fluids, and the Hydraulic Instruments dependent upon it.

Throughout the whole, an attempt has been made to bring the principles of exact science to bear upon questions of practical application in the arts, and to place the discussion of these within the reach of the more intelligent of that useful class of men who are connected with the manufactures of the country.

The Author has to acknowledge his obligations to the work of M. Dupin, entitled *Mécanique appliquée aux Arts*, for several of the illustrations of the Parallelogram of Forces, and the Centre of Gravity; and to the popular work of Dr. Lardner on Hydrostatics, for the rules stated to be those which govern the relation of the changes of the barometer, to the changes of the weather.

# INTRODUCTION TO THE STUDY

OF

## NATURAL PHILOSOPHY.

It is essential to the development of the energies of that intellectual principle which is within us, that an intercourse be established between it and the material existences without. The immaterial and undying soul is, in this, our present state, so wrought around and entrammelled by its material appendages, as to be incapable of any availing exercise of its powers until they have first been schooled and disciplined by that intercourse. Without it, reasoning there could be *none*, where there would be no *data*; memory none, where nothing had been perceived; imagination none, where there was no reality. The body might combine all the existing elements of its power and beauty; the blood of life might flow through it; the soul might hold in it her accustomed seat; and the senses, her ministers, might be disposed around, ready to do her bidding; but were there no external objects whereon to occupy those senses, or were the sentient principle careless or unable to avail herself of their ministry, the whole would present the emblem of a death-like repose, of a perpetual and dreamless sleep.

For the carrying on of this intercourse, man is provided, in the organs of sense, with means, of boundless application, and of most exquisite contrivance. The Hand, for instance, is capable of moving accurately to any point; of varying the quantity and direction of its motion and pressure in every conceivable way; and, by habit, it may be made to measure and to take notice of this power and direction with inconceivable minuteness. The manual skill acquired by painters, sculptors, and operative mechanics, is no other than the application of a knowledge of the effects of different, and of exceedingly minute, developements of force, accurately measured, both as to their quantity and direction, in the mechanism of the hand, and treasured, with these results, in the memory. It is beyond the power of imagination to conceive the variety and complexity of

tained, the next EIGHT CHAPTERS present the application of these to the Inclined Plane, the Wedge, the Lever, the Wheel and Axle, the Screw, and the Pulley; usually termed the Mechanical Powers.

Chapters Fourteen and Fifteen contain the theory of the equilibrium of systems of variable form. It is shown, that the conditions of the equilibrium of a rigid system are *necessary* to the equilibrium of the same system, when made to admit of variation in its form, but not *sufficient*. And from this principle are deduced certain conditions of the equilibrium of polygons and frames of rods and cords, of the catenary, and finally, the conditions of the equilibrium of bodies in contact, including the Arch.

Chapter Sixteen contains a Discussion, of Dr. Young's theory of the strength of materials, and a table of moduli of elasticity and extension. In Chapter Eighteen, will be found Lagrange's celebrated Demonstration of the principle of Virtual Velocities, which it has been attempted to bring within the comprehension of ordinary readers; and Chapter Nineteen, which contains the theory of Resistances and a demonstration of the new principle of Least Resistance, completes the theory of Statics.

The theory of Hydrostatics or the Equilibrium of Fluid Bodies, presents the extreme case of the equilibrium of a system of variable form. Any portion of such a fluid mass in equilibrium, is therefore subject to the same conditions, as though it were a solid; together with such other conditions as result from its fluidity. It is on this principle, that the whole theory of Hydrostatics is built.

In the First Chapter is discussed the principle of the equal distribution of fluid pressure; in the Second, the conditions of the equilibrium of a heavy fluid; in the Third, the oblique pressure of a heavy fluid, the forms of embankments, the centre of pressure, &c.; the Fourth Chapter treats of the conditions of the equilibrium of floating bodies; the Fifth, of specific gravity, and the instruments used for determining it: and the last, treats of the Science of Pneumatics, or the Equilibrium of Elastic Fluids, and the Hydraulic Instruments dependent upon it.

Throughout the whole, an attempt has been made to bring the principles of exact science to bear upon questions of practical application in the arts, and to place the discussion of these within the reach of the more intelligent of that useful class of men who are connected with the manufactures of the country.

The Author has to acknowledge his obligations to the work of M. Dupin, entitled *Mécanique appliquée aux Arts*, for several of the illustrations of the Parallelogram of Forces, and the Centre of Gravity; and to the popular work of Dr. Lardner on Hydrostatics, for the rules stated to be those which govern the relation of the changes of the barometer, to the changes of the weather.

# INTRODUCTION TO THE STUDY

OF

## NATURAL PHILOSOPHY.

It is essential to the developement of the energies of that intellectual principle which is within us, that an intercourse be established between it and the material existences without. The immaterial and undying soul is, in this, our present state, so wrought around and entrammelled by its material appendages, as to be incapable of any availing exercise of its powers until they have first been schooled and disciplined by that intercourse. Without it, reasoning there could be *none*, where there would be no *data*; memory none, where nothing had been perceived; imagination none, where there was no reality. The body might combine all the existing elements of its power and beauty; the blood of life might flow through it; the soul might hold in it her accustomed seat; and the senses, her ministers, might be disposed around, ready to do her bidding; but were there no external objects whereon to occupy those senses, or were the sentient principle careless or unable to avail herself of their ministry, the whole would present the emblem of a death-like repose, of a perpetual and dreamless sleep.

For the carrying on of this intercourse, man is provided, in the organs of sense, with means, of boundless application, and of most exquisite contrivance. The Hand, for instance, is capable of moving accurately to any point; of varying the quantity and direction of its motion and pressure in every conceivable way; and, by habit, it may be made to measure and to take notice of this power and direction with inconceivable minuteness. The manual skill acquired by painters, sculptors, and operative mechanics, is no other than the application of a knowledge of the effects of different, and of exceedingly minute, developements of force, accurately measured, both as to their quantity and direction, in the mechanism of the hand, and treasured, with these results, in the memory. It is beyond the power of imagination to conceive the variety and complexity of

its operations. Writing is one of the simplest of them, and yet, in the formation of every written character, there takes place a certain minute development of force, varying in quantity, and direction; which is accurately poised in the hand as to its quantity, measured as to its direction, and *remembered*, and may be re-produced, the same, even without the assistance of the sight.

The Hand serves further as a probe, to measure the degrees of the hardness or softness of bodies, and the smoothness of their surfaces; as a balance, to compare their weights; as a thermometer, to estimate their temperature.

The Ear estimates for us the motions of the minute atoms of that form of matter (the air,) which is among the most subtle; regular vibrations of the atmosphere, when made with different velocities, producing distinct sounds. And, similarly, the Eye notes the motions of the still more minute particles of light, indicating their different relations in the varieties of colour. How exquisite must be the mechanism which enables us thus to measure the force of impulses of whose existence the lightest body we can conceive, however delicately suspended, will, when opposed to them, give no perceptible evidence; impulses of atoms so minute, as to be incomparably less than the smallest portion of matter whose distinct existence we have ever been able to recognise!

Exquisitely wrought as are the senses of hearing and sight, who will assert that any superfluous contrivance has been bestowed on their construction? Were it not for the perfect sympathy thus established between our organs of sensation, and those subtle fluids of air and light which pervade the space in which we exist, all that we see, having distinctness and form, and all that we hear of modulated sound, would have been lost to us. There might, with less of contrivance in the eye, have been the perception of light, but there could have been none of those exquisite varieties of shade and colour which enable us to appreciate the objects we look upon; and so, with a less delicate mechanism of the *ear*, there might have been hearing, but all distinction of the rapid and evanescent varieties in articulate sound would have been impossible, and there could have been no perception of measured harmony.

Not only has man the means of carrying on the intercourse thus essential to all that constitutes his active existence, but he is irresistibly impelled to the use of those means, and to the establishment of that intercourse; for, the circumstances in which man is placed, impel him, of necessity, to acquire the

knowledge which he has thus the means of acquiring. He is so constituted as never to be capable of deriving entire satisfaction from anything which he may obtain. Not only is he gifted with senses enabling him to distinguish the minutest differences of external things, but each of the perceptions which he thus obtains is coupled with an emotion equally delicate and varied, of pleasure or pain. Thus exquisitely *sensitive*, he finds himself urged perpetually by wants which nothing in the world he inhabits offers *itself* to gratify, liable to calamities which nothing, of itself, intervenes to screen him from; and he is never without the hope of some enjoyment, or the terror of some suffering.

This *apparent* destitution of man is the great element of his intellectual and physical superiority; inasmuch as it forces him to the acquisition of that KNOWLEDGE in which he finds the secret of supplying his wants. Nature has so ministered to the comforts of inferior animals as to limit the wants they are themselves called upon to supply to a definite and an exceedingly small number; and limited as these wants, are their means of perceiving the qualities of the external things which are necessary for their gratification.

Man is a creature of *boundless* desires and wants, and he is thus intellectually and physically great, because his desires and his wants are thus boundless. Urged on in a perpetual round of new sensations, every one of which is more or less permanently registered by the memory, and rendered an element of knowledge; he may be called emphatically, as distinguished from all others, a *learning animal*. Had he possessed no other distinctive qualification than that of organs infinitely better suited than those of any other class of animals, to convey to his mind distinct perceptions of the material world in all its modifications, coupled with equally acute emotions of pleasure and pain, together with unlimited desires for the enjoyment of the one, and for exemption from the other; and, thus constituted, had he been placed as we find him in a world where nothing was supplied to his hand, for the gratification of these desires; where every desire and every suffering pointed to the KNOWLEDGE of some class of material existences, through which that desire might be satisfied, or that pain avoided: were there no higher attributes of humanity than these, it is scarcely possible to affix a limit to the superiority which might, even with these aids, be acquired by it in the scale of existence.

Here, then, is evidence of wisdom and goodness even in the *wants* and the *sufferings* which have been allotted to man, emi-



nently calculated to reconcile him to the discomforts which it has pleased Heaven to place around him—the restlessness of those desires which are implanted in his bosom, and his *apparent* destitution in creation—elements, as these are, of that which constitutes his pre-eminence. With power almost creative over the material existences around him—with knowledge, the secret of applying that power—with senses, admirably adapted for acquiring that knowledge—and with necessities, impelling him to its acquisition—let us combine the godlike faculty of REASON, a principle of life to the whole, and we behold in man a being created for dominion in this lower world. “Thou, O God, hast made him a little lower than the angels, and hast crowned him with glory and honour. Thou madest him to have dominion over the works of thy hands.”

Thus furnished for combating with the physical evils around him, how complete is his triumph over them! He piles up for himself a dwelling in which, surrounded by an artificial heat, he endures the storm, and may, if he chooses, scarcely be sensible of the variety of the seasons. One animal he strips of its coat for his covering, the life of another is sacrificed for his food, and a third bears his limbs in luxurious ease. The earth no longer produces the variety of her own spontaneous fruits, but yields her increase under the exercise of his skill. Her natural boundaries impose no restraint upon him, the inequalities of her surface vanish from his path, and he harnesses the winds to his chariot and traverses her seas. No distance removes her stores beyond his reach. Within the boundaries of civilization it is to be doubted whether there be any individual so destitute or so wretched that the four quarters of the globe do not daily minister to his necessities or his comfort.

When, in obtaining for himself the objects of his desires, his own strength fails him, he seizes upon the forces inherent in matter, and brings them, in all their stupendous energy, to cooperate with his feebleness. He can accumulate the weight or attraction of inanimate matter to any extent, and direct its combined operation to any point; that power, as existing in fluid matter, he can cause to transfer itself any where, disseminate itself through any space, and exert itself in producing effects, however minute, or however powerful; in sweeping away the smallest particle of dust, or causing to revolve a vast complication of machinery. He holds in equal mastery that force of repulsion which also pervades matter as universally as attraction, and which we call heat. He can unloose it from the mineral substances amidst whose atoms it lies bound. He

can infuse it into others whose parts are held together by forces inconceivably greater than any we can appreciate; he can overcome those forces, and separate those parts. He can cause it to insinuate itself, for instance, within the pores of the diamond, scatter the cohesive power which constitutes it the hardest of material bodies, and dissolve it in air. In its combination with fluids, in the form of steam, he can accumulate and concentrate this repulsion to any extent, and cause it to transfer itself to any point where it may suit him to avail himself of its energies.

No less complete is his control in the application of these powers when acquired. By the intervention of machinery he can vary their quantity and direction in any way; concentrate them so as to cause forces, acting through ever so large a space, to exert themselves through ever so small a one, with energies greater as that space is less. He can again dilute these in any degree, so as to cause them to exert a feebler influence over a larger space. The same quantity of power which, with infinite lightness, but inconceivable rapidity, fines the point of a needle, may thus, under another form, be made slowly to lift the hammer of a forge. To carry on the analogy of a fluid, he can pour this *force* from one body to another, accumulate successive influxes, and then throw their united energy wherever he chooses to avail himself of it. How wonderfully is it seen acting in the different parts of a manufactory, moving as it were through huge channels along its centre, thence diffused in smaller veins to its extremities, and yielding there to each workman a fountain of power proportioned to his wants!

It is not, however, in respect to his physical nature alone that he is thus elevated in creation. In respect to his moral and religious nature also, man enjoys a high privilege in the converse which it is permitted him to hold with the Most High in his works. However a knowledge of the truths of Natural Science may offer to him the means of augmenting his temporal welfare, did the study of them produce an influence pernicious to him in regard to that welfare which is eternal, who would not wish that they should for ever be to him as a sealed book? But it is not so. The principles of physical science, if rightly viewed, point directly to *some* of the great and most important truths of REVELATION; above all they lead directly to an assured knowledge of the existence and attributes of God. "For the *invisible* things of him from the creation of the world are clearly seen, being understood by those things which are made, even his eternal power and GODHEAD\*."

\* Romans i. 20.

The following are some among those numerous processes of inductive reasoning by which this great truth of revelation may be arrived at.

It is an early operation of the mind, when it turns to the consideration of its own perceptions, to make a distinction between such as it derives perpetually the *same*, when the senses are directed to the same objects, and those which are in their nature momentary, or at least transitory. The former, it classes as *properties* or *qualities*; the latter, as *facts* or *actions*. Of these facts or actions, it is among the first perceptions of every one, that some are subject to his own volition, that it depends upon himself to produce their existence or not. Himself thus acting he designates a *cause*; and the fact or thing done, an *effect*. Further, among the facts or actions themselves, to which he thus stands in the relation of cause, he traces a similar dependency, so that each fact is connected with some other or others, by a relationship, essential to its existence. This necessary relationship, like the other, he calls by the name of *cause* and *effect*. The difference of the cases lies only in this, that the one is voluntary and the other necessary. To the class of facts which are dependent, is given the name of *effects*; and of *causes*, to those on which they depend. When the actions of which he is himself the immediate cause, become in their turn the causes of others; to these last, they are said to stand in the relation of *secondary* causes, and himself of *primary* cause. These secondary causes may in their turn become causes of others, and these of others, and so on through an infinite sequence, to the whole of which he stands in the relation of primary cause.

Now, turning from the facts which are thus linked with his own volition, to those which are independent of himself, he traces a similar sequence. There is a perpetual chain of cause and effect visible through all Nature. Wherever he directs his investigation, he finds causes which are but the effects of others, and these of others in a perpetual chain. Is it wonderful, that here too (to complete the analogy) he should look for a *first cause*? A first cause, to which this infinity of sequences stands in the same relation that he does to such as are the creatures of his own volition. Although his search for that first cause among the beings whose existence is made known to him through the medium of sensation, be in vain, yet, ascending through the chain of causes, he has a distinct consciousness that he is approximating to the *first cause*. The number of facts which he perceives to stand in the relation of causes to the rest, continually diminishes as he proceeds, until at length, he arrives at certain

of them, beyond which his senses refuse to carry him; and these seem to him to stand next in order to the first cause. They may be classed under the heads of **TIME, SPACE, MATTER, and FORCE.** The consideration of these in all their relations, and through the whole chain of effects which grow out of their combination, constitutes the science of **NATURAL PHILOSOPHY, or PHYSICS.**

The science of **MECHANICS**, which, perhaps, properly includes the whole, has been limited to those general principles which govern the operations of force, in combination with matter, whatever may be the nature of that force. Natural Philosophy includes with this the investigation and discussion of the forces themselves, as to their nature and distinctive properties.

Time and Space are, in their nature, *one*, and indivisible. We can conceive no separation of their parts, such as that, in their interval, there should be *no* time or *no* space. These the mind readily admits to be primary effects and secondary causes. Of Matter and Force, there are numerous varieties already known, and many may remain to be discovered. It is impossible, with any confidence, to rank all these varieties in the list of primary effects. The number of existences, believed to stand in immediate relation to the first cause, has hitherto continually diminished, as science has advanced; philosophers having, in each succeeding age, contrived to establish a dependence between causes, which those of some preceding age had deemed secondary and independent.

Every thing then leads to the conclusion, that the real number of secondary existences is exceedingly small. Does not this look like the mode of the operation of a *single* agent? Why this apparent economy in creative energy? Why these traces of singleness of effort? Is it not precisely the manner in which we seek to exert our own energies as far as we are able, within the little sphere of operation which is allotted to us? Supposing our *finite* wisdom, knowledge and power, to become *infinite*, our nature remaining in other respects the same, should we not thus seek to economize our efforts, in obedience to a law of that nature, by which we are now perpetually impelled to a like economy?

Are we not then led to the conclusion, that these few primary existences, thus endued with a power of infinite reproduction, spring from the hands of a Being, to whose nature our own bears some infinitely remote, but still distinct resemblance? The truth thus indicated by reason, is confirmed by Revelation. "God created man in his own image, in the image of God created he him."

In considering the relations of Time, Space, Matter, and Force, one of the first things that strike us, is the uniformity of those relations. Such that the same cause shall, under the same circumstances, always produce the same effect. This uniformity constitutes a Law; and each particular relation of cause and effect, thus uniform, is a LAW OF NATURE. It is evident that the science of Natural Philosophy mainly consists in the study of these laws. It may be defined as the science whose province it is, *to trace the chain of causes and effects in natural things, and to determine the laws of their relations.*

Of Natural Laws, there are different orders, as there are of causes. Primary laws, or principles, are placed with primary causes *beyond* the sphere of sensation. The term principle is, however, used *relatively*; any cause being designated a principle in reference to causes lower in the chain of sequence.

With regard to the actions which are the immediate subjects of his own volition, every one perceives that he has the power of modifying and varying them, together with the sequence of cause and effect growing out of each, in every conceivable degree, and that he has also the power of adjusting his effort as first cause, so as to produce a certain remote effect, and neither more nor less than that effect. This adaption of the primary cause (and with it of all the intermediate causes,) to the remote effect, he calls DESIGN.

It is this power of *design*, or *contrivance*, which distinguishes the relation of cause and effect, in living and intelligent beings, from that which exists in the operation of inanimate agents and unintelligent beings. Wherever we trace this relation of cause and effect, coupled with design, there we therefore conclude the existence and operation of an intelligent being. Now this design is MANIFEST throughout Nature. Every blade of grass, every bud, every leaf, every blossom that the wind strews around us, every one of those organized and living beings which crowd the interstices of matter, each of these, in its order, proclaims design in the operation of that first cause to which it owes its being; and thus it proclaims the existence of a living and intelligent Creator.

This argument from design has been rendered familiar to every one by the admirable work of Paley.

Turning again from the contemplation of the works of God in the universe, to the consideration of his *own* powers, man perceives that not only can he render those powers available for the production of certain remote effects, but further, that he can render those other *external* powers, over whose action he has no

control, available to the same end. Not in any way modifying those powers, for that is impossible,—the mode or law of their action being by the will of the great First Cause, but *applying* them. Thus, he can avail himself of the gravitating force, or weight, of a stone, to produce either pressure or impact; the action of the *stone* is the same, but in the one case the impulses of gravitation which it continually receives are as *continually* destroyed, whilst in the other, their accumulated energy is destroyed altogether. Nay, further, he has power to bring about the action of these natural causes upon one another. He can bring, for instance, matter under the action of force; he can subject these in every variety to the influence of time and space. He can, further, induce the operation of these combinations in every possible degree upon one another.

Now looking into the natural world, he perceives that there must have taken place in it some such operation as that of which he thus finds himself capable. All that now exists, might then have existed as it does now; there might have been every atom of matter, every particle of force, and the same space occupied through the same time, and these subject to the same laws; and yet had not these been brought under the operation or influence of one another, there would have remained a state of things, the disorder of which it is beyond the power, or even the province, of imagination to conceive. The whole would have remained without form and void, replete with the elements of disorder, and the subject of perpetual change. Here, then, we trace again, evidence of the operation of a First Cause, bringing together what we have termed second causes, and thus applying their combined action according to the laws which he has himself first imposed upon them, according to a method of operation to which man finds something similar, but inconceivably inferior in degree, in his own power.

THERE is yet another proof of the existence of the Deity, drawn from strictly scientific considerations, and founded indeed in the very principles of science, so striking, and yet so little generally known, that it cannot be *here* misplaced, although in calling the attention of the reader to it, it will be necessary, as the argument is of some difficulty, to bespeak his *attention*.

Force, considered as a *principle*, or *cause*, of motion, resides *permanently* in every particle of matter, whether it be animated matter or not, the subject of an invariable law, and CONSTANTLY in action. In *animated* beings a further portion of it is lodged under the implicit direction of the will; at one time *active*, at

another *inert*. Now the effects of this principle of force, in communicating motion to bodies capable of moving freely in space, *differ*, according as the cause is thus *constant* in its action, or *intermittent*. In both cases the velocity communicated by each impulse is *retained*; but in the one case the impulses are continually repeated, and the velocity resulting from each is accumulated in the moving body; whilst, in the other, there is not necessarily any repetition of the impulse, and the resultant velocity, if there be no such repetition, is uniform. If, therefore, we can trace, in nature, the existence of free motion *unaccelerated*, we are assured that it cannot have resulted from the operation of any of the *permanent* forces now acting in matter, and that it must have sprung from a principle no longer apparent in it, similar to that we find residing only in animated beings. Now *there is that motion*. Looking into the system of the universe, we behold motions, which the *existing* force of *gravity* is not sufficient, alone, to account for; we find effects, which cannot have resulted except from the operation of a principle whose action has ceased; an impulsive force, similar to that which we find placed under the direction of our own volition. Were there no other cause in action, the planets would each direct its course towards the sun, and all matter would, long ago, have collapsed in his substance.

There is no force acting *now* to draw them obliquely in space, for, if it act *now*, it must have acted from all eternity, and be a permanent force. The orbit and the quantity of motion of each planet would then, demonstrably, be other than it is. Here, then, is proof that at some previous period, there acted a Power impulsively upon each, by which it was projected into space in a direction other than that which it would, by its own inherent attraction, have taken. "We understand, then, that the worlds were framed by the word of God, so that, the things which are seen were not made of the things which do appear\*." We *know* that when the universe assumed its position in space, there was there a Being endued with power similar to that which we find residing in animated beings, and which we call life. We know that "there was a hand by which the heavens were stretched forth, and a spirit by whom their hosts were commanded."

Not only, however, do the planets revolve round the sun, but about certain axes within themselves, producing thereby the alternations of day and night; and these axes are inclined at certain angles to the planes of their revolution, thereby bringing

\* Heb. ii. 3.

about the variety of the seasons. Now to effect all this, as we find it effected, the one original impulse must have been made with a certain force, in a certain direction, and at a certain point, on the surface of each planet. Here, then, is design. And when we consider that the whole of Animated Nature is contrived with a view to the alternations of light and heat,—the green leaf, the bud, the blossom, and the fruit, in vegetables; the clothing, much of the internal organization, and the energy and duration of the principle of life, in animals—do we hesitate to admit that design to be the emanation of infinite wisdom?

It may be asserted, that these are evidences indeed of the operation of a creative power, but of that power acting in submission to pre-established laws of force, and that it remains to ascertain the existence of a Being in whom those laws have their origin. To this argument, again, science furnishes us with a direct answer. Although this principle of force is shrouded from our view with a mystery, which Nature throws about no other of her operations, yet here too, are we enabled to see far enough to distinguish infinite contrivance in the laws by which it is governed; and contrivance is indubitable evidence of creative wisdom.

There is observable throughout nature, a wonderful economy of this principle of force. Animal beings, in whom it is placed in subjection to the will, are impelled to that economy, (under the direction of instinct, or reason,) by the sense of weariness and exhaustion. In every particle of inanimate matter, it is implanted, directed to the same object, by infinite wisdom. Accordingly, we find in the former class of beings, perpetual efforts at the economy of force, which are necessarily feeble and erring; and in the latter, *that* economy perfect. Throughout inanimate nature, all is done with the least possible action; no developement of force, however minute, is thrown away.

The nature of the principle to which reference has been made will, perhaps, be better understood from the following illustration. If I wished to ascend or descend a hill, or pass from one portion of it to another, with the least possible muscular exertion, or expense of force, a slight consideration would show me that the precise path to be pursued, would be dependent on the form and inclination of the different parts of the hill; upon the nature of my own muscular energies; and upon other data, of which I could scarcely by any possibility acquire a knowledge, and on which when known, my intellectual powers would be quite insufficient to enable me to found a conclusion. Under these circumstances, the chances are infinitely greater,



that I should select the wrong than the right path. Now, if I were to project a stone up the hill, or obliquely across it, or suffer it to roll down it, whatever obstacles opposed its motion, whether they arose from friction, resistance, or any other cause, constant or casual, still would the stone, when left to itself, ever pursue that path in which there was the least possible expenditure of its efforts; and if its path were fixed, then would its efforts be the least possible in that path. This extraordinary principle is called that of least action; its existence, and universal prevalence, admit of complete mathematical demonstration. Every particle of dust blown about in the air, every particles of that air itself, has its motions subjected to it. Every ray of light that passes from one medium into another, deflects from its rectilinear course, that it may choose for itself the path of least possible action; and for a similar reason, in passing through the atmosphere, it bends itself in a particular curve down to the eye. The mighty planets, too, that make their circuits *ever* within those realms of space, which we call our system; the comets whose path is beyond it; *all* these are alike made to move so as best to *economize* the forces developed in their progress.

Now, those forces which are *not* developed by living beings, are planted in the substances in which they reside, by the hand of God, and subjected to the laws which he from the beginning imposed upon them. It has pleased the Almighty, then, that the works of *his* hands should ever be wrought in accordance with that principle of least effort which he has also implanted as a principle of our nature in *us*, and which, thus impelled, we ever develop more or less, in our own feeble efforts. The difference lies only in this, that in him this principle acts controlled by infinite wisdom, and therefore, its operation is *perfect*: with us it manifests itself under the guidance of a limited knowledge and most erring judgment, and its development partakes in their imperfection. In the adjustment of his efforts, so as to produce the required effect with the least possible expense of force—it has been shown, then, again, that (according to a great truth of revelation) man is created in the image of God, and that he retains the resemblance. The principle of force lodged in each particle of matter, has been believed to be but a direct emanation of the Deity, *there* acting continually, and at every moment. The scrupulous economy of force, the wonderful store (if the expression may be used) which Nature sets by it, strongly points to that conclusion.

Man was created in the image of God. And it has been

shown, that, in the possession of a power, almost absolute, over the material existences around him; and, in the exercise of an intellect whose resources no effort would seem to exhaust—and, in the manner in which he exercises that power and that intellect—he may yet be said to retain traces of that original from which he first sprung, and that image wherein he was first created.

Do not these reflections at once suggest the *contrast* of his moral condition? What does this description of his majestic bearing in creation, the extent of his physical powers, the resources of his intellect, and his resemblance, in respect to his physical nature, to the God who made him, so forcibly present to the mind as the degradation of his moral nature, and its fall from that perfect image in which we may reasonably conclude that it too, as well as his physical nature, was first created?

Here, then, is another great truth of revelation suggested by the reasonings of Natural Science.

It has been deemed expedient to be thus full in endeavouring to show the direct and necessary tendency of the study of Natural Philosophy, to strengthen our belief in some of the first and fundamental truths of revelation, because an opposite tendency has been attributed to it.—Were it not an impiety to discuss the manifestations of infinite wisdom and goodness in created things, otherwise than with sentiments of gratitude to the Creator, and of deep humility before him, it could at best be considered but as an affectation or a folly. It is impossible to consider a course of instruction complete, which, having for its object to develop the relation of cause and effect in those portions of the sequence of natural things which lie within the scope of sensation, does not point out their dependence upon that First Cause which is beyond it. To be taught correctly, the truths of Natural Science must be taught with a frequent and direct reference to the wisdom, the goodness, and the power of the Author of Nature. The study of Natural Philosophy and Natural Theology, if rightly pursued, are one; and true science but a perpetual worship of God in the “firmament of His power.”

It may be asserted that we are sufficiently assured of the existence and attributes of the Deity, by that revelation which He has been pleased to make of Himself in his word; and that, even were this not the case, yet that the proofs of it are *manifest and every where*; that they require no study, and constitute no science. But, alas! although it be true that the earth is

“full of the goodness of God,” and that His existence, power, and wisdom, *are every where* to be traced, yet, (erring and feeble as we are,) the very abundance and repetition of that proof have a tendency to render us insensible to it. Now science opens to us, on these points, *new* views infinitely more striking than any that can be seen by the untutored intellect; views calculated to impose gratitude on the most insensible, and to bend in worship the minds of the most stubborn.

It has been attempted to point out the physical advantages which man derives from a knowledge of the laws which govern the relation of cause and effect, in inanimate nature. This attempt will probably be met by the assertion that the knowledge necessary to secure to us these advantages demands no study, and constitutes no science; that it is necessarily attained or readily attainable by all of us. That all the knowledge of natural things which is really practical and useful is given by every man's experience.

It is true that there is a vast fund of knowledge which is acquired by us all in common, and in which Nature herself is our instructress; a fund of knowledge, in comparison with which all the extraordinary and artificial acquirements of any of us above our fellow-men is probably as dust in the balance. The whole sum of knowledge which a savage, for instance, must have acquired, before he could frame together the materials of his hut, or hollow out his canoe, is perhaps greater than the *additional* knowledge requisite to convert that hut into a mansion, or replace that canoe by a ship of the line. But it is equally true that this *common* knowledge has long ago exhausted itself in our *common* comforts. If we would *add* to the well-being of society we must *know more*. It is a great but a prevalent mistake to suppose that the inventions which have of late so greatly augmented our physical happiness, have resulted either from chance, or from the speculations of men untaught in science. The very reverse has been the case. There is scarcely a valuable mechanical discovery of modern date, which is not in its nature essentially scientific, and dependent upon principles either not generally known, or not to be acquired without considerable research.

If it be urged that men eminent for their inventions have at any rate advanced but little beyond mere principle, it may be answered that it was because those applications of science to the arts which constitute their inventions were to be found even in its principles, and on its threshold, not because there were not other and even more valuable applications beyond it.

Science, in all its departments, is rich in knowledge applicable to the wants of society. It is when practical men add to their experience sound views in theory, that it is made to contribute its resources to the public welfare. This is, however, an exceedingly rare union. The arts are, consequently, vastly behind philosophy. The practical man imagines unreal difficulties in the attainment of scientific knowledge, and consoles himself by underrating the advantages which science has to offer him. The man of science, wrapt up in the pride of abstract reasoning, will not trouble himself to encounter practical difficulties. His vocation is to discover; to smooth the paths and to extend the domains of knowledge; it belongs to the other to follow in his steps, and to apply it. The considerations which have been here stated have suggested the plan of the following work.

The object of the work, then, is to make known to practical men, and others whom it may concern, those great principles, which abstract science has shown to determine the conditions of the equilibrium and the motion of material bodies, subjected to the operation of force in all its modifications. And to do this, as far as it may be possible, by direct experiment, or by elementary reasoning directly founded upon experiment.

The author is convinced that much sound and useful mechanical information may thus be communicated to those who have acquired no previous mathematical knowledge. And most valuable of all scientific knowledge as he holds that to be, yet does he think it in the highest degree desirable that all such scientific truths as admit of application to the wants of life, and of being *soundly* (that is, demonstratively,) communicated, without reference to abstract principles, should *so* be communicated. At the same time he begs to state, that he can offer a knowledge of the subject of which he is about to treat, to no one who is not gifted with a certain share of intellectual aptness, and who does not possess an inquiring spirit,—a disposition to attend to that which is taught him, and an ability to think for himself.

There is no method of acquiring sound scientific information, without thought and persevering attention on the part of the student; and there is no other than *sound* information which can be useful, either as a discipline and high accomplishment of the mind, or as practically applicable in the arts. The business of philosophy is with the *understanding*. That knowledge is falsely and meretriciously called *scientific* knowledge, which is *intended* for the memory, and takes its standing *there* exclusively, and which, consisting in no real acquirements in

*any* science, is commonly accompanied by great presumption in *all*. This is a knowledge which can have no other earthly use than to enable men, by adroit management, to take a certain position in society as men of science to which they have no legitimate claim, and to make them egregiously vain of their success.

The influence of the study of Physical Science, considered as a branch of general education, directed to the ultimate formation of character, is this, that it inspires in the student an abstract love of truth, whenever and wherever it is to be met with; an intense pleasure in the pursuit of it; and an insuperable contempt for sophistical reasoning, and unfounded pretension. By dint of continually applying himself to the search, he at length comes to be possessed with an ardent love for the thing sought. And his efforts in the search of it go not unrewarded; he finds it with certain evidence, he is penetrated with its beauty, he stores it as a gem of inestimable price, and soon acquires correct ideas of his own power to develop it, together with an intuitive perception where it may certainly be found, and where not.

When the ingenuous mind of youth has thus once been imbued with a true estimate of its own resources, and the humility which is ever the result of that knowledge, with that unmeasured dislike for presumption and error, that indomitable love of truth, that passion for its investigation, and that unwearied patience in separating it from falsehood, which science never fails in a greater or less degree to give; how does it go forth into the business of life? It may be deficient in that promptitude and readiness of wit which, although it have no sort of alliance with, and in fact seldom accompanies, sound intellectual endowments, may yet have its use, as passing current for them in society. This science may not give, but there are none of the high and honourable avocations of life, for which such a discipline of the mind will not have abundantly prepared it.

# STATICS.

## CHAPTER I.

- |  |  |
|--|--|
| 1 Definition of Force.   | quantity and direction, by Lines.                                |
| 2 Its Direction.   | 17 The Parallelogram of Forces.                                  |
| 3 Its Effect the same wherever applied in the Line of its Direction. | 19 Resultant and Component Forces.                               |
| 4 The Equilibrium of Forces.   | 20 The Resolution and Composition of Forces.                     |
| 5 The Equality of Forces.  | 21, 22 The Equilibrium of Three Forces acting upon a solid Mass. |
| 8, 9 The unit of Force.  | 23 Illustrations of the Parallelogram of Forces.                 |
| 10 The Measure of Forces.  |  |
| 14 Representation of Forces, in                                      |  |

1. FORCE is that which tends to cause, or to destroy motion.
2. The direction of a force is, that in which it tends to cause or destroy motion in the point to which it is applied.
3. It is found by experiment, that the effect of a force acting in a given direction on a solid mass, is the same at *what-ever point* it is applied to it, provided only that point lie in the direction of the force.

Thus, if forces act in the directions  $P_1p_1$ ,  $P_2p_2$ ,  $P_3p_3$ , upon the solid mass  $ABC$ , these all produce the same effect as though they were applied to it any where in the lines  $P_1p_1$ ,  $P_2p_2$ ,  $P_3p_3$ , or in these produced.

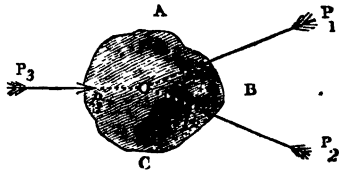

Thus, for instance, they produce the same effect as though they were applied to it in  $o$ ; provided that, as in the figure, they intersect in  $o$ .

4. Any number of forces, which being applied to a body, destroy one another's tendency to communicate motion to it, and thus hold it at rest, are said to be in equilibrium.

5. When a body is held at rest by two forces, these are said to be equal to one another\*.

6. It is found by experiment, that *two forces* cannot hold a body at rest, unless they act in opposite directions, and in the same straight line.

\* The body is supposed here to be acted upon by no other forces whatever, besides these two.

7. If, instead of applying the two forces which are thus equal in opposite directions, we apply them both in the *same* direction, the force which must be applied in an opposite direction to sustain the *two* is said to be double of either of them. If we take a third force, equal to either of the two first, and apply the three in the same direction, the force which must be applied in the opposite direction to sustain the three, is said to be triple of either, and so for any number.

8. Thus, fixing upon any one force, and ascertaining how many forces equal to this are necessary, when applied in an opposite direction, to sustain any other force, we shall arrive at a true conception of the amount of that other force, in terms of the first, and may compare it with any third force whose amount has been ascertained by reference to the same standard.

9. The single force, in terms of which the amount of any other force is thus ascertained, is called an *unit* of force.

10. Forces, whose amount is ascertained in terms of some *known* unit of force, are said to be *measured*.

11. The units of force which it is found most convenient to use, are the weights of certain portions of matter, or the forces with which they tend towards the centre of the earth. The quantities of matter whose weights are used as units of force are different in different countries.

12. With us the unit of force, from which all the rest are derived, is the weight of 22·815\* cubic inches of distilled water, called one *pound* troy. This being divided into 5760 equal parts, the weight of each is a grain troy, and 7000 such grains constitute the pound avoirdupois.

13. When we wish to represent the value of a force, we usually write down the number of the units contained in it; and annex to the figures expressing that number, the designation of each unit. Thus, 15 pounds avoirdupois, represents a force equivalent to fifteen units; each unit being one pound avoirdupois; that is, each being the weight of a quantity of distilled water, found by dividing 2235 cubic inches of it into 5760 equal parts, and taking one of these parts 7000 times.

14. *Another* method, however, of representing the value of a force may be conceived.

 If we take a line AB, composed of any number of equal parts, and suppose each part to represent an unit; then

\* This standard is fixed by an Act of Parliament, bearing date June 25, 1824. The temperature is supposed to be 62° Fahrenheit, and the barometer to stand at 30 inches.

will the whole line convey to the mind an accurate idea of a force of as many units as there are such parts in it. Now it is evident that on this hypothesis, the *actual* length of the line is immaterial. Two lines AB and CD of different lengths may, in fact, represent the same force; the lengths of the parts P and P', representing units, being different\*. For instance, P and P' each representing one pound, either line will represent seven pounds.

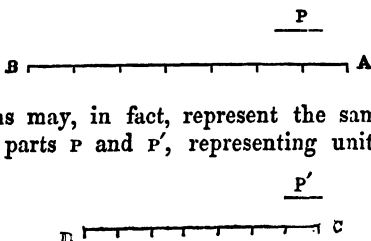

15. Lines taken as above, to represent forces in *magnitude*, have this further advantage, that they may be made to represent them also in *direction*. Thus, if two forces act upon a point in directions inclined to one another at a certain angle, and two lines AO and BO be drawn inclined to one another at that angle, then taking any line D, to represent an unit of either force, and measuring OP so as to contain D as many times as there are units in the one force, and OQ so as to contain it as many times as there are units in the other; these lines PO and QO will represent accurately not only the relative magnitudes of the forces; but their relative directions. And the conception we shall obtain of them from the diagram will be complete, if when they act *towards* o, they be supposed to be represented by PO and QO; and by OP and OQ, when they act *from* it. PO and QO taken as above, are said to represent the two forces concerned in *magnitude* and *direction*.

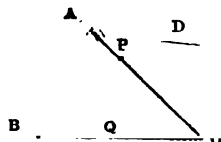

16. It is quite clear that these two forces will not hold the point to which they are applied at rest, not being equal to one another, or acting in the same straight line, and in opposite directions. (See Art. 6.) A *third* force is necessary to the equilibrium. The magnitude and direction of that third force may be determined as follows.

\* The lines or parts, taken as above, to represent *units* of force, are in the following treatise, called units of length. It is evident that if we fix upon the length of the line to represent a force, we shall find the unit of length by dividing the line into as many equal parts as there are units in the force; and conversely, if we fix upon the unit of length, we shall find the length of the line representing the force, by repeating that unit of length as many times as there are units in the force.



17. Through the extremities  $P$  and  $Q$  of the lines  $QO$  and  $PO$ , draw two other lines,  $QR$  and  $PR$ , one of them  $QR$  parallel

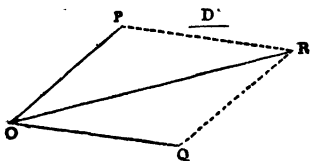

to  $OP$ , and the other  $PR$  parallel to  $OQ$ . The four will then form a parallelogram  $POQR$ . Join its two opposite angles  $O$  and  $R$  by the straight line  $OR$ . Then this line  $OR$ , called the diagonal of the parallelogram, represents the force which will hold the

other two at rest, in magnitude and direction. Or, in other words, if we take a force containing a number of units equal to the number of times the line  $D$  is contained in  $OR$ , and apply this force at  $O$  in the direction  $OR$ , it will just be in equilibrium with the other two.

This remarkable law of the *Parallelogram of Forces*, which governs the equilibrium of any three forces of whatever kind, may be stated as follows. *If three forces acting upon a point are in equilibrium, and lines be measured from this point in the directions of the forces, so as to contain, each, a given unit of length, as many times as there are units in each force; then these lines will form the adjacent sides and diagonal of a parallelogram.* It may be shown to be a necessary consequence of a few exceedingly simple and self-evident principles. Unfortunately, the deduction requires, however, considerable mathematical knowledge, and lies beyond the scope of a work like the present\*.

18. It is, nevertheless, easy to assure ourselves of the truth of this law by experiment. The accompanying figure represents a circular frame or ring of wood, supported firmly in an upright position, upon a stand. Moveable pulleys  $P_1, P_2, P_3$ , are so contrived as to admit of being fastened at any points of the circumference of this ring, having their wheels† parallel to its surface. Weights  $w_1, w_2, w_3$ , are then attached to fine siken cords passing over these pulleys, and knotted together in a point  $O$ . The system being left to itself, will, after a time, assume a position in which it will rest. The three forces acting at  $O$ , having in that position the directions necessary to their equilibrium. Now, if the hollow portion of the ring be filled up by a board, slightly receding from its anterior surface, so as to allow the system of strings to move perfectly free of it,

\* See Appendix A.

† These wheels must be made with every precaution against friction; the axle should be fixed in the wheel.

and upon this board (which may be covered with paper, or blackened, so as to admit of having lines drawn upon it with pencil or chalk), we draw lines in the directions of the strings  $OP_1$ ,  $OP_2$ , and  $OP_3$ ; then, taking any line  $D$  for an unit of length, and setting off this line  $D$  (with a pair of compasses) as many times along the line  $OP$  (beginning from  $o$ ) as there are units of weight (ounces for instance) in the weight  $w_1$ , and along  $OP_2$  as there are of these units in  $w_2$ ; and completing the parallelogram  $OPRQ$ , by drawing lines upon the board, from  $R$  and  $Q$ , parallel to  $oq$  and  $oP$  respectively; we shall find that  $D$  will be contained as many times in the diagonal  $OR$  as there are units of weight in  $w_3$ , and that this diagonal will be in the same straight line with  $OP_3$ . Now, the lines  $OP$  and  $oQ$  represent

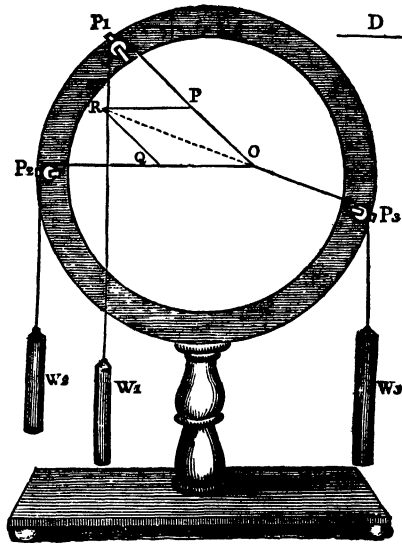

two of the forces acting at  $o$  in magnitude and direction; and these are held at rest by  $w_3$ , acting in the direction  $OP_3$ , which last is shown to be represented by  $OR$  in magnitude and direction: and this is true, whatever be the magnitudes of the weights  $w_1$ ,  $w_2$ ,  $w_3$ , or the positions of the pulleys  $P_1$ ,  $P_2$ ,  $P_3$ : whence the truth of the proposition is apparent\*.

\* Among the apparatus of the class of Natural and Experimental Philosophy in King's College, is a parallelogram  $OPRQ$ , made of thin slips of box-wood, divided into inches and tenths. These are connected together at the angles by moveable joints, and each of the points  $P$  and  $Q$  so contrived that it may be made to slide along either of the sides which it connects together. A slip of wood,  $OR'$ , of sufficient length to form a diagonal to the parallelogram, moves freely with  $OP$  and  $oQ$ , on the joint  $o$ . —From the extreme lightness of the materials, the weight of the whole is exceedingly small.

This instrument is thus applied to prove the proposition stated in the text: An inch, half, quarter, or eighth of an inch, being fixed upon as the most convenient unit of length, the joint  $P$  is made to slide along  $OP$ , until that line contains as many of these units as there are units of weight in  $w_1$ ;

19. If, instead of the forces  $OP$  and  $OQ$ , we apply at  $O$  a force represented in magnitude by the line  $OR$ , and acting in that line from  $O$  towards  $R$ , it is clear that the point  $O$  will remain at rest, the forces applied to it being equal and opposite. The same effect resulting from the action of the single force,  $OR$ , as from that of the two  $OP$  and  $OQ$ , (viz. the support of the force in the direction  $OP_3$ , and the equilibrium of the point  $O$ ,) it is said to be their *resultant*,  $OP$  and  $OQ$  being called its *components*.

20. Conversely, if a force, represented in magnitude and direction by the line  $OR$ , sustain a force acting in the direction of the line  $OP_3$ ; and we take forces acting in any two other directions,  $OP_1$  and  $OP_2$ , and represented in magnitude by lines  $OP$  and  $OQ$ , determined by drawing from the point  $R$  lines  $RP$  and  $RQ$ , parallel to the directions  $OP_2$  and  $OP_1$ ; then, if these forces be made to replace the single force  $OR$ , the equilibrium will remain under the same circumstances as before. The force  $OR$  is then said to be *resolved* into the two  $OP$  and  $OQ$ , and these are said to be *equivalent* to it. The directions  $OP_1$  and  $OP_2$  are any whatever. A given force may, therefore, be resolved into two others, in any given directions whatever.

and, in the same way,  $OQ$  is made to contain as many units of length as there are units of weight in  $w_2$ .  $PR$  and  $QR$  are then made, by means of

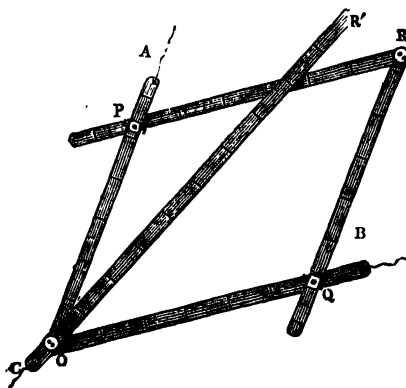

other sliding joints at  $P$  and  $Q$ , to be of the same lengths with  $OQ$  and  $OP$ . Strings are then fastened to the extremities  $A$ ,  $B$ , and  $C$ , of the slips  $OA$ ,  $OB$ , and  $OR'$ ; and these are passed over the pulleys  $P_1$ ,  $P_2$ , and  $P_3$ , (see p. 31), and attached to the weights  $w_1$ ,  $w_2$ ,  $w_3$ . The system being now left to itself, the equilibrium will take place under the same circumstances as before; and the slip  $OR'$  will be found to have assumed the position of the diagonal  $OR$ , and to contain as many of the assumed units of length as there are of the units of weight in  $w_3$ .

We may vary the experiment by altering the weight  $w_3$ ;  $w_2$  and  $w_1$  remaining the same. The system will then take up a new position; but still  $OR'$  will be found to coincide with the diagonal  $OR$ , and the length of this diagonal to have been increased or diminished by the same number of units as the weight  $w_3$ .

This instrument was made by Messrs. Watkins and Hill, of Charing Cross.

It is clear, that, whatever be the number of forces acting upon the point  $o$ , we may replace any one of them,  $oR$ , by two,  $oP$  and  $oQ$ , into which it is resolved; and conversely, we may replace any two,  $oP$  and  $oQ$ , by their resultant,  $oR$ .

21. *Knowing the directions of the three forces which hold a point at rest, and the magnitude of one of them, we can determine the magnitudes of the other two forces.* For we know that lines representing the three in magnitude and direction, will form two adjacent sides and the diagonal of a parallelogram; taking, therefore, a line representing the known force for any one of these parts of the parallelogram, we have only to complete it so that the two other parts may be in the *directions* of the two remaining forces. These parts will then represent those forces in magnitude, and they will consequently be known to us.

Thus, if three forces act upon the point  $o$ , in the directions  $oP$ ,  $oQ$ ,  $oR$ , (fig. page 30,) and the magnitude of that which acts in  $oP$  be known; then, representing this force by  $oP$ , in order to determine the magnitudes of the other two, we have only to form a parallelogram, of which  $oP$  is one of the sides, and which has its other side and diagonal in the directions of  $oQ$  and  $oR$ . Such a parallelogram will evidently be formed by drawing through  $P$  a line parallel to  $oQ$ , until it intersects the direction of  $oR$ , in  $R$ , and through  $R$ , a line parallel to  $oP$ , intersecting  $oQ$  in  $q$ .

22. If a body be acted upon by three forces, and these hold it at rest, the lines in which they act will, when produced, meet in the same point. Let  $F_1 p_1$ ,  $F_2 p_2$ ,  $F_3 p_3$  (see fig. page 27), be the directions in which three forces act upon the body\*  $ABC$ , being applied to it at the points  $p_1$ ,  $p_2$ ,  $p_3$ . Produce  $F_1 p_1$ , and  $F_2 p_2$ , to meet in  $o$ . Now, the force  $F_1 p_1$  will produce the same effect, at whatever point we suppose it to be applied to the body, provided that point be in the line  $F_1 o$ , in which the force acts (Art. 3); and the same is true of the force  $F_2 p_2$ . The forces  $F_1 p_1$ ,  $F_2 p_2$ , produce, therefore, the same effect upon the body as though they were applied to it in  $o$ . They have, therefore, for their resultant, a force acting through that point. Now, supposing them to be replaced by their resultant, it is clear that the body will be acted upon only by two forces, namely, this resultant and the third force,  $F_3 p_3$ ; and, since it is at rest, these must act in the same straight line, but in opposite directions (Art. 6); that is, the resultant of the forces  $F_1 p_1$  and  $F_2 p_2$ , which passes through  $o$ , must be in the same

\* The body is to be supposed without weight.

straight line with  $P_1 p_1$ ,  $P_2 p_2$ , when produced, must, therefore, pass through  $o$ .

The above demonstration applies, strictly, only to that case in which the directions of the forces, when produced, meet at some point *within* the body; it may, however, be applied to the equally common case, in which they meet at some point

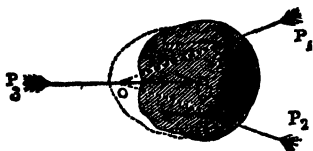

without it. For let us suppose  $P_1$  and  $P_2$ , when produced, to meet in a point  $o$ , without the body. Then, although we cannot at present suppose the forces to be applied to the body in  $o$ , the body, in fact, not existing there, yet we may suppose it to be extended, so as to include that point, without altering the conditions of the equilibrium; provided, that by so extending it we do not in any way add to or diminish the forces which already act upon it. The forces and their points of application remaining the same, it is clear, that if they were in equilibrium before, they will be so now. Now conceiving the body to be thus extended, so as to include the point  $o$ , the case will resolve itself into that which we have before considered.

existing there, yet we may suppose it to be extended, so as to include that point, without altering the conditions of the equilibrium; provided, that by so extending it we do not in any way add to or diminish the forces which already act upon it. The forces and their points of application remaining the same, it is clear, that if they were in equilibrium before, they will be so now. Now conceiving the body to be thus extended, so as to include the point  $o$ , the case will resolve itself into that which we have before considered.

#### APPLICATIONS OF THE PRINCIPLE OF THE PARALLELOGRAM OF FORCES.

THERE is scarcely any case of equilibrium, in which the principle of the composition of forces acting upon a point does not find its application. Out of the variety of illustrations which present themselves, we shall select the following:—

23. Let us suppose a given weight,  $w$ , to be supported, as

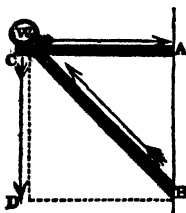

in the accompanying figure, by means of a horizontal beam,  $AC$ , abutting in a vertical wall at  $A$ , and sustained at its opposite extremity by an oblique stay,  $BC$ ; and let it be required to determine the thrust\* and strain upon the timbers  $AC$  and  $BC$ , and upon the wall at  $A$  and  $B$ . Draw  $BD$  parallel to  $AC$ , and  $CD$  to  $AB$ ; divide  $CD$  into as many equal parts as there are units of weight in  $w$ , and find how many such parts there are in  $CA$  and  $CB$ . The numbers thus obtained will equal

\* A thrust is that force which, acting in the direction of the length of a timber, tends to compress it. A strain, that which tends to lengthen it.

those of the units of weight in the pressures in  $AC$  and  $BC$ . For the point  $c$  is held at rest by forces in the directions  $CD$ ,  $CA$ , and  $BC$ . These, therefore, are represented in magnitude and direction by the sides and diagonal of a parallelogram. (Art. 17.) Now, (Art. 14,)  $CD$  represents one of these in magnitude and direction, and  $CA$  and  $BC$  are in the directions of the other two. If, therefore, we construct a parallelogram, having  $CD$  for one of its sides, and having another in the direction  $CA$ , and its diagonal in the direction  $CB$ , this will be the parallelogram of forces acting at  $c$ . (Art. 21.) The only such parallelogram which can be formed, is manifestly  $ABCD$ .

If,  $c$  remaining the same, we cause the point  $B$  to move towards  $A$ , giving to  $CB$  a more inclined position and shortening it,  $CD$  will be diminished; and, dividing it as before into as many parts as there are units in  $w$ , each of these parts must be less than before; the number of parts equal to them in  $AC$  must, therefore, be greater than before, and, therefore, the number of units of weight in the pressure on  $AC$  must be greater; and similarly it may be shown, that the pressure on  $CB$  is increased. In the above investigation we have neglected the weight of the timbers themselves.

*The Russel Press.*— $AC$  and  $BC$  represent two bars jointed together at the point  $c$ ; these being placed between two surfaces,  $A$  and  $B$ , on one or both of which pressure is to be produced, a force is made to act upon the joint  $c$ , in the direction of  $PQ$ . The tendency of this force to increase the angle  $ACB$  is resisted by the surfaces at  $A$  and  $B$ ; this resistance is propagated along the rods  $AC$  and  $BC$ , and when there is an equilibrium, the point  $c$  is held at rest by forces acting in the directions  $AC$ ,  $BC$  and  $PQ$ . To determine the first two forces, knowing the last, we have, therefore, only to complete a parallelogram,  $ACBD$ , and to divide its diagonal,  $CD$ , into as many parts as there are units in  $PQ$ ; the numbers of these parts contained in  $AC$  and  $BC$  will ascertain for us the pressures required. (Art. 21.) It is clear that as  $CD$  is less, or the angle  $ACB$  greater,  $CD$  will be less, and therefore the magnitude of each of the parts into which  $CD$  is divided, will be less, and the numbers of these in  $AC$  and  $BC$  greater; the pressures in these directions will, therefore, be greater. Also when  $CD$  is exceedingly small, or  $AC$  and  $CB$  nearly in the same straight line, these parts being exceedingly small, the number of times they are contained in  $AC$  and  $BC$  will be exceedingly great. Thus the

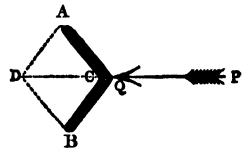

pressures on A and B may be increased without limit by bringing A C and B C more nearly into the same right line.

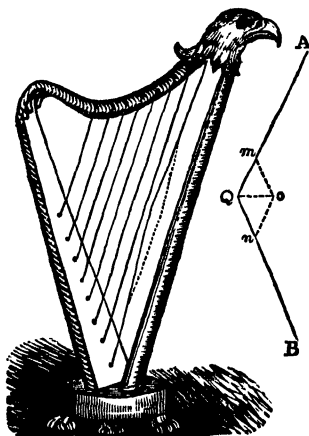

25. The mechanical contrivance to which the strings of harps are attached, enables the tuner to distend them with a force equal to four or five times that of his wrist\*; yet a child has in its fingers sufficient power to sustain their tension when but slightly deflected. This is readily explained:—If A Q B represent the deflected string, and we complete the parallelogram  $Qmno$ , of which the equal sides  $Qm$  and  $Qn$  represent, each, the tension of the cord, the diagonal  $oQ$  will represent the disturbing force, when it just sustains these tensions (Art. 17); and this is,

manifestly, exceedingly small, compared with the former, provided the deflexion be small.

26. A very simple illustration of the principle may be drawn from the method usually adopted in tightening the cord

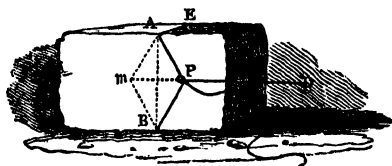

of a package. A portion of the cord having been passed transversely round it, in the direction A B E, and pulled tight by means of a slipping-knot on the opposite side to

that shown in the figure, the remainder is made to traverse it longitudinally, and, being passed under the cord A B, is pulled backwards; and it is found, that, however tight A B E may before have been drawn, a very slight force thus applied in the direction P D is sufficient to produce a considerable deflexion of the cord between A and B, and thus increase the tension upon that cord, and tighten it throughout its whole length. The amount of this tension may readily be determined. Completing the parallelogram  $APBm$ , we have only to divide the diagonal  $Pm$  into as many equal parts as there are units in the force we

\* It has been calculated by M. Prony, that the strings of a piano are stretched by a force equivalent to that of four horses.

exert in the direction  $P D$ . The number of these parts contained in  $P A$  or  $P B$  will give us the number of units of force in the tension (Art. 17).

27. Suppose an arrow to be drawn back into the position  $E F G$ , immediately before it is released from the bow; the force which is exerted by the hand of the archer at  $G$ , to resist the expansion of the bow, is that with which the arrow is discharged. Now, the point  $G$  is held at rest by this force, and the tensions of the string in the directions  $G C$  and  $G D$ .—These tensions are equal, if the string be drawn by the right hand, and the bow bent by the left, each *precisely in its middle point*.

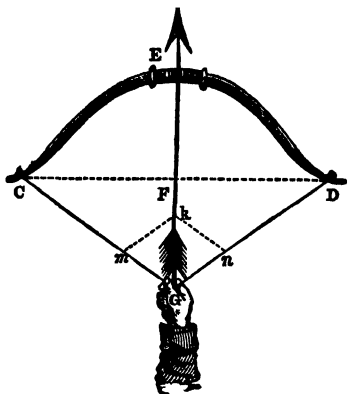

Taking, then, two equal lines,  $G m$  and  $G n$ , to represent these tensions, and completing the parallelogram  $m k n G$ , the resultant (Art. 19) of these, being that force with which the arrow is discharged, will be represented by the diagonal  $G k$  (Art. 17). It is clear that  $G k$  is greater as the bow is more bent.

28. *The direction in which a body acted upon by any number of forces first moves, is manifestly that in which a single force of sufficient magnitude might be applied, so as to hold it at rest. Such a force is equal, and opposite to the resultant of the forces which act upon the body. Hence, therefore, conversely, the direction in which a body moves is that of the resultant of the forces which act upon it.*

29. The resistance of the air to the motion of each of the wings of a bird is perpendicular to the surface of the wings. And the force with which the bird urges itself forward with each wing, is in a direction

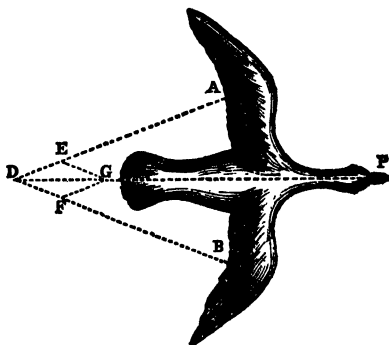



opposite to this resistance. Draw  $DA$  and  $DB$ , perpendicular to the surfaces of the two wings; then  $DA$  and  $DB$  are the directions of the forces by which the bird impels itself forward with each wing. Take the lines  $DE$  and  $DF$  to represent these forces in magnitude, and complete the parallelogram  $EGF$ ; their resultant  $DG$  (Art. 19), thus determined, is in the direction in which the bird is made to move. If the wings be similarly extended, and the force which the bird exerts with each the same; the lines  $AD$  and  $BD$ , will make equal angles with the line  $PD$  passing through the centre of the bird's body, and  $ED$  and  $FD$  being equal,  $DG$  will coincide with that line. So that the motion of the bird will be directly forward.

29. The forces by which a swimmer impels himself, are in directions perpendicular to the soles of his feet, and the palms

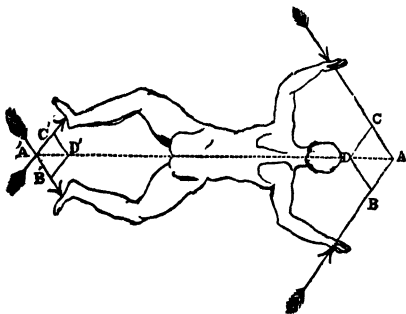

of his hands. If these be equal on either side of his body, his motion is in the direction of its length, the resultants of both forces lying in a line passing through the centre of his body. If the force with which he moves one foot be greater than that with which he moves the other, one of the adjacent

sides of the parallelogram,  $A'B'C'D'$ , being greater than the other, the diagonal will tend towards the greater side, and the motion of the lower part of the body will be in that direction. If he use greater force with that hand which is on the same side the body, the resultant of the forces on the hands will, on the contrary, be from that side; and the head will move towards that side, and thus his body will be turned round.

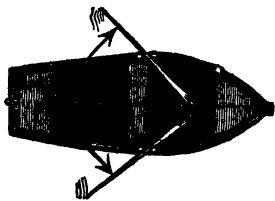

30. The rowing of a boat presents another case of a body impelled by forces applied obliquely on either side; but having their resultant in the direction of its length.

31. The sails of a ship may be so placed, as to cause it to move in a direction greatly

different from that in which the wind blows; and in fact, if required, to hold a course directly in opposition to it. Suppose the wind to come in the direction  $PQ$ , and one of the sails of the vessel to be placed obliquely to it in the direction of  $CD$ . Take  $PQ$  to represent the force of the wind, and complete the parallelogram  $PRTQ$ ; having the side  $TQ$  parallel to the sail, and  $QR$  perpendicular to it. The force  $PQ$  is then equivalent to the two (Art. 29),  $TQ$  and  $RQ$ , of which  $TQ$  being applied in a direction parallel to the surface of the sail, takes no effect upon it. The only effective force is, therefore,  $RQ$ . Draw  $QM$  parallel, and  $QS$  perpendicular to a line passing through the centre of the vessel, and complete the parallelogram  $QMRs$ . Then the force  $RQ$  is again equivalent to the two  $MQ$  and  $sQ$ , of which the former tends to give the vessel a motion in the direction of its length, and the latter sideways. The latter force is opposed by the action of the fluid on the broadside of the vessel; the former, by its resistance on the sharpened prow. Hence, the motion sideways, called its lee-way, is exceedingly small, compared with that in the direction of its length.

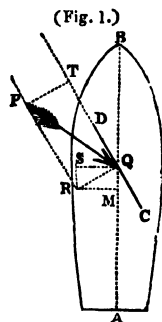

(Fig. 1.)

It is clear, that if the wind blew in the direction  $BA$  (fig. 1), it could not be made to fall upon that surface of the sail  $CD$  which is towards the stern of the vessel, on which surface it must evidently fall, so as to impel the vessel, in any degree *forwards*. To cause the wind to fall on this surface of the sail, we must incline the position of the vessel to its direction.

Suppose it to be required to sail from  $B$  to  $A$  (fig. 2); the wind blowing directly from  $B$  to  $A$ , and let the vessel be brought round with its head in some direction  $BP$  inclined to  $BA$ . The sails may then be so placed, as that the wind may fall obliquely upon them, and it will move in the direction  $BP$ . Having sailed for a time on this tack, its course may be altered to  $PQ$ ; and a third tack will bring it to  $A$ .

(Fig. 2.)

Q



CHAPTER II.

- 32 The Equilibrium of any number of Forces applied to a point.    34 Illustration of the Polygon of Forces.  
 33 The Polygon of Forces.

32. To determine the conditions of the equilibrium of any number of forces acting upon a point. Let the lines  $o P_1, o P_2,$

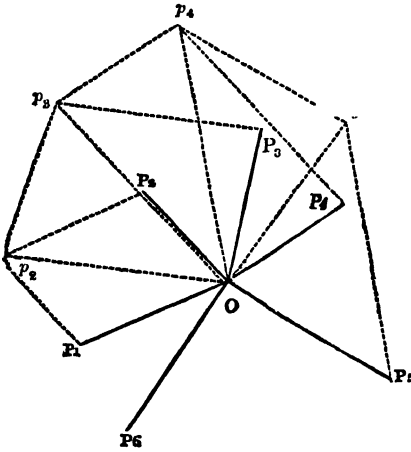

&c., represent in magnitude and direction any number of forces\* acting upon the point  $o$ . Through the points  $P_1$  and  $P_2$ , draw  $P_1 P_2$  and  $P_2 P_3$  parallel to  $o P_2$  and  $o P_1$ , respectively, and join  $o P_3$ . Then the two forces  $o P_1$  and  $o P_2$  are equivalent to a single force represented in quantity and direction by  $o P_3$ . (Art. 19.) Through  $P_3$  and  $P_2$  draw lines  $P_3 P_2$  and

$P_2 P_3$ , parallel to  $o P_2$  and  $o P_3$  respectively, and join  $o P_4$ . Then  $o P_3$  represents in magnitude and direction a force equivalent to  $o P_2$  and  $o P_3$ ; and, therefore, to  $o P_1, o P_2,$  and  $o P_3$ ; since  $o P_2$  is equivalent to the two first of these. Similarly, if we draw through the points  $P_4$  and  $P_3$  lines parallel to  $o P_3$  and  $o P_4$  respectively, and join  $o P_5$ , that line will represent a force equivalent to the two  $o P_3$  and  $o P_4$ ; that is, to  $o P_1, o P_2, o P_3,$  and  $o P_4$ ; that is, to  $o P_1, o P_2, o P_3,$  and  $o P_4$ . In like manner, it may be shown, that if  $P_5 P_4$  and  $P_4 P_5$  be drawn parallel to  $o P_4$  and  $o P_5$  be joined, this last line will represent a force equivalent to  $o P_1, o P_2, o P_3, o P_4, o P_5$ .

Since, then, the force  $o P_5$  is equivalent to all those which act upon the point, excepting only the force  $o P_6$ ; if the point be kept at rest by these, the forces  $o P_5$  and  $o P_6$  must be such as would hold it at rest; that is, they must be equal and opposite.

\* It is immaterial whether the forces be in the same plane or not.

Thus, knowing the directions and magnitudes of any number of forces,  $OP_1, OP_2, \&c.$ , and finding a force  $Op_s$ , equivalent to them, as explained above, we know the magnitude and direction of another force,  $Op_s$ , sufficient to complete the equilibrium, and keep the point  $o$  at rest. The force  $Op_s$  is the *resultant* of the five,  $OP_1, OP_2, OP_3, OP_4, OP_5$ .

It will be observed that the line  $OP_1$ , represents the first force, and that  $P_1 p_2$ , which is equal to  $OP_2$ , (being opposite sides of a parallelogram,) represents the second in magnitude, and is parallel to its direction; and, similarly, that the lines  $p_2 p_3, p_3 p_4, p_4 p_5$ , represent the other forces in magnitude, and are parallel to their directions. Now, these lines form the sides of a polygon,  $OP_1 p_2 p_3 p_4 p_5$ , which the resultant,  $Op_s$ , completes.

33. Hence, therefore, *if any number of forces act upon a point and we take a polygon, one of whose sides is formed by the line representing one of the forces, and the other sides in succession by lines representing the other forces, in magnitude, and parallel to their directions, then the line which completes the polygon will represent the resultant of the whole.* This proposition is called that of the polygon of forces. Its discovery is attributed to Leibnitz.

34. The following is an instance, among many others, of the action of more than three forces. Great bells, which it is beyond the power of one man to move, are rung by the joint effort of several men. These pull each a rope, attached to the main rope of the bell, the force upon which is the *resultant* of their individual efforts. The amount and direction of this resultant may, in all cases, be readily found.—Let  $OP_1, OP_2, OP_3, \&c.$ , represent the directions in which the forces of the different ringers are exerted. Draw, parallel to these, the lines  $p_1 p_2, p_2 p_3, \&c.$ , representing in magnitude the force exerted by each, and forming sides of a polygon. The line  $p_1 p_5$ , completing the polygon, will represent the magnitude and direction of the *resultant* force,

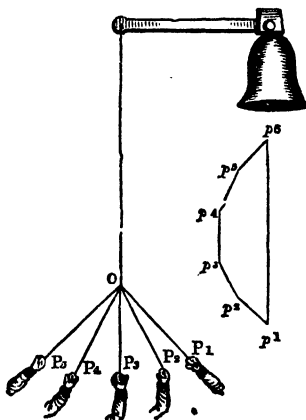

The ringers at each bell are commonly placed at equal dis-

tances round the circumference of a circle, having a point immediately beneath the main rope for its centre. Supposing the forces they respectively exert to be equal, their resultant will be in the vertical direction of the main rope itself, and will have no tendency to communicate a lateral or oblique motion to it.

### CHAPTER III.

On the Equilibrium of a number of | in a Body, but acting all in the  
Forces applied to different Points | same Plane.

35. ON a smooth horizontal table, let a flat board  $ABC$  be laid\*, and let there be fixed any where round the edge of the table a series of pulleys,  $P_1, P_2, P_3$ , &c., (in planes at right angles to its plane), each having the highest portion of its circumference on a level with the surface of the board. Attach strings to the points  $p_1, p_2, p_3, p_4, p_5$ , any where taken on the surface of the board, and having passed them over the pulleys  $P_1, P_2, P_3$ , &c., fasten to their other extremities weights,

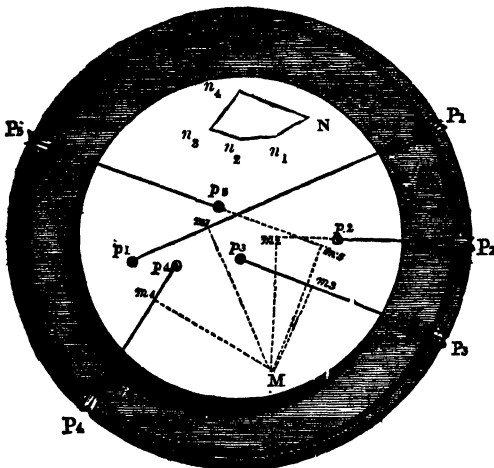

which we will suppose to be represented also by the letters  $P_1, P_2, P_3, P_4, P_5$ †. Let the system now be left to itself; when it has attained a state of equilibrium, there will be found to exist the following remarkable relation between the quantities and

\* To prevent friction, the board should be made to rest on three small ivory balls, so placed as not to be brought into contact. It is a yet better expedient to float the board in a vessel of water, so that its surface may rise slightly above the edges of the vessel, on which the pulleys are to be fixed.

† The weights are not shown in the figure. Experiments of this class are the more accurate, as the weights, and the diameters of the pulleys, are greater, and the rigidity of the cords, and the friction opposed to the motion of the board, less.

directions of the forces applied to it. If from *any* point  $M$ , in the plane of the surface of the board, we draw perpendiculars  $M m_1, M m_2, M m_3, \&c.$ , upon the directions  $P_1 p_1, P_2 p_2, P_3 p_3, \&c.$ , of the different forces acting upon it, and multiply the number of units in the length of each perpendicular by the number of units in the force on whose direction it is drawn; then the sum of these products, taken in reference to those forces which tend to turn the system about that point, in one direction, will be found to be equal to the sum of those taken in reference to the forces tending to turn it in the opposite direction\*. Thus, in the figure, if the force  $P_1$  be multiplied by  $M m_1$ †,  $P_2$  by  $M m_2$ , and  $P_3$  by  $M m_3$ , and the sum of these products taken, it will be found that this sum will equal that of the products,  $P_4$  by  $M m_4$ , and  $P_5$  by  $M m_5$ . The product of the force, by the perpendicular upon its direction upon any given point, is called the moment of that force about that point. Hence, therefore, the law may be stated thus.

\* Experience proves to us the following important law of statics; that if any system of forces be applied to a body, so as to be in equilibrium, and a second system of forces be applied to the same body also in equilibrium, then the conditions of this last equilibrium shall be precisely the same as though the first system of forces did not exist; the two sets of forces not interfering in any way with one another. Thus, if there be two sets of forces, and either of them will keep the body at rest, when applied to it separately, then the two will keep it at rest when applied together; and conversely, if two sets of forces applied to a body, hold it at rest, and it is known that the forces composing one of these are in equilibrium with one another, then it is also known that the forces of the other set must be in equilibrium amongst themselves. In the investigation of the laws of statics by experiment, it is of great importance to bear this fact in mind. The great obstacle to the experimental method of investigation consists in the impossibility of our obtaining any portion of matter, whereon to apply the forces, the conditions of whose equilibrium we wish to investigate, which is not already acted upon by the force of gravity; the nature and amount of whose action upon it we must be supposed not to know. The difficulty is got over at once, by causing the body on which we are about to experiment, to be acted upon by forces which will just neutralize its gravity or weight. The conditions of the equilibrium of the forces we then apply, will be precisely the same as though no others acted upon it. The experiment in the text presents an example of this. The board is, in point of fact, acted upon by two sets of forces: its weight and the resistances of the balls in directions *perpendicular* to the plane of its surface; and the tensions of the strings *in* that plane. Now we know, that the forces of the first set are in equilibrium with one another, for if we take away the cords, so that its weight and the resistances of the balls may be the only forces which act upon the board, it will remain at rest. Hence, therefore, we conclude, that the forces of the second set, which are those acting in the plane of the board, are also in equilibrium. The principle stated above is called that of *the superposition of forces*.

† In this and in other parts of this treatise, where force is spoken of as *multiplied by a line*, the number of units in the force is to be understood as multiplied by the number of units in the line.

36. *Any number of forces, acting any where in the same plane, and any point being taken in that plane, the sum of the moments of the forces tending to turn the system in one direction about that point, is equal to the sum of the moments of those tending to turn it in the opposite direction.*

37. This is not, however, all; it will further be found, *that, if the forces acting upon the different points of the system be transferred to a single point, and applied to that point parallel to their present directions, they will hold it at rest.* There must, therefore, further exist between them, that relation which is necessary to the equilibrium of forces acting upon a point.

38. On the whole, then, forces acting as above, upon any number of different points in the same plane, *are subject, first, to the same conditions which govern the equilibrium of forces acting upon a point: and, secondly, to this further condition, that the sums of their opposite moments about a point any where taken, are equal to one another.*

39. These conditions do not only obtain wherever there is an equilibrium, but wherever they do obtain, we are sure that there *must be* an equilibrium. They are not only *necessary*, but *sufficient*. Hence, therefore, if we have a system of forces not in equilibrium, and we would wish to equilibrate, or place it in equilibrium, we have only to add such other force or forces, as will cause the above conditions to obtain in the system.

Let us suppose the system represented in the figure to be acted upon by the forces  $P_1, P_2, P_3, P_4$ , and let it be required to determine the amount of the force  $P_5$ , and the direction in which it must be applied, so as to produce an equilibrium. Take any point  $N$  in the plane of the surface of the board, and through it draw a line  $Nn_1$ , parallel to  $P_1 p_1$ , representing the force  $P_1$  in magnitude (Art. 14); and through  $n_1$  a line,  $n_1 n_2$ , parallel to  $P_2 p_2$ , and representing  $P_2$  in magnitude. Draw  $n_2 n_3$  and  $n_3 n_4$ , similarly representing the forces  $P_3$  and  $P_4$  in magnitude, and parallel to their directions; then joining  $N n_4$ , this line must represent the remaining force,  $P_5$  in magnitude, and be parallel to its direction. (Art. 33.)

We have now determined  $P_5$  to be of such a magnitude, and parallel to such a direction, that it may cause the system to satisfy the first condition of the equilibrium; namely, that the forces should be such as, if applied to a *point*, would hold it at rest. It remains to apply this force to such a point of the system, as to cause that *equality of the moments* which constitutes the second condition. With this view, let us take any point  $M$ , and ascertain the sums of the opposite moments of the forces

$P_1, P_2, P_3, P_4$  about that point. Comparing these sums with one another, we shall know how much is wanting to their equality. We have only then to apply  $P_5$  parallel to its proper direction,  $n n_5$ , at such a distance from  $m$ , as that its momentum shall just make up the equality.

We shall at once find this distance, if we divide the difference of the sums of the moments about  $m$ , by the force  $P_5$ , determined as above.

The easiest method of determining the line in which  $P_5$  is to be applied, will be to draw through  $m$ , a line  $m m_5$ , equal in length to the distance found above, and perpendicular to the direction of  $n n_5$ . A line  $P_5 p_5$ , perpendicular to this through its extremity, is that in which the force must be applied.

40. If any number of forces be in equilibrium, a force equal and opposite to any one of them is the resultant of all the rest. For if all the rest were taken away, and this one put in their place, the equilibrium would manifestly remain; since it would exactly sustain that single force to which it would, under these circumstances, be opposed. There would result, therefore, from the action of this single force, the same effect as resulted from the action of those which have been taken away, or it is their *resultant*. Hence, then, in finding the force necessary to produce an equilibrium among the forces in the last article, we have, in fact, found their resultant; for we know that that resultant will be a force equal and opposite to this which we have found.

41. One of the conditions of equilibrium may obtain among a number of forces without the other. Thus the equality of moments may obtain among the forces, and yet these may not be such as, applied to a point, would hold that point at rest (See Art. 38.) In this case we may find the amount of the force  $P_5$  necessary to produce equilibrium in the system as before, also the line  $n n_5$  parallel to its direction. Now, in order to produce the equilibrium, this force must be placed in the system, so as not to destroy the equality of moments which at present exists; it must, therefore, have no moment about  $m$ ; for if it had any, it would increase the sum of the moments, tending to turn the system one way, or the other. The perpendicular from  $m$  upon the direction of this force must therefore equal nothing, or its direction must pass through  $m$ . And the direction of the resultant is opposite to that of this force.

42. *The resultant of any number of forces, the sums of whose moments about a given point are equal, passes, therefore, through that point.*



43. Let us suppose any one of the forces of a system in equilibrium to be represented in magnitude, as well as in direction, by a line,  $Pp$ , containing as many units of length as there are units in that force, and draw lines from  $P$  and  $p$  to  $M$ , forming, with  $Pp$ , the triangle  $MPp$ . Now, by a well-known proposition in geometry, twice the area of this triangle is equal to the product of the number of units in the base  $Pp$ , by the number in the perpendicular  $Mm$ . But this product is the moment of the force. That moment is, therefore, equal to twice the area of the triangle. Hence, therefore,

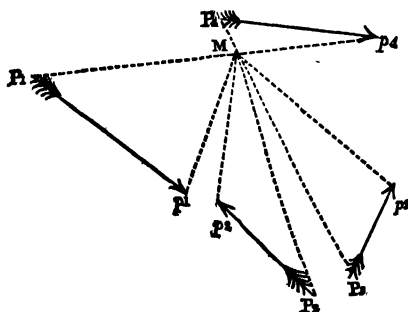
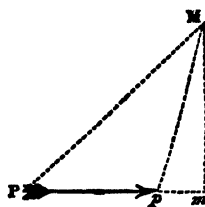

if we take as above a series of lines,  $P_1p_1$ ,  $P_2p_2$ ,  $P_3p_3$ , &c., to represent the forces of the system, and join their extremities with the point  $M$ ; the areas of the triangles thus formed being doubled, will respectively equal the moments of those forces; and, since the sums of the moments, in respect to forces acting in opposite directions, are equal, the sums of the areas of the triangles, being doubled, are equal; and, therefore, the halves of these, or the sums of the areas of the triangles themselves, are equal\*.

44. Thus, then, we have the following important law. *If we represent any number of forces acting in the same plane, and being in equilibrium, by lines, and join the extremities of all these lines with any point in the plane, then the sum of the areas of the triangles thus formed, which have for their bases forces tending to turn the system in one direction, shall be equal to the sum of those having for their bases forces tending to turn it in the other direction.*

45. If all the forces acting upon the system be parallel to

\* Thus if the forces in the figure be in equilibrium, (their directions being represented by the directions of the arrows,) then the areas of the triangles  $P_2M p_2$  and  $P_4M p_4$  must equal, when added together, those of the triangles  $P_1M p_1$  and  $P_3M p_3$ .

one another, the same line which is perpendicular to one of them, will, when produced, be perpendicular to all the rest. The moment of each force is, therefore, its distance from the point  $M$ , measured along this line, multiplied by the number of units in the force. In order that there may be an equilibrium, the sum of these moments, in reference to the forces tending to turn the system in one direction about  $M$ , must be equal to their sum, in reference to those tending to turn it in the other direction.

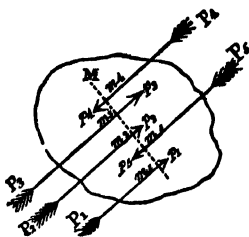

46. Further, the forces themselves must be such as, being applied parallel to their present directions to a single point, they would hold that point at rest. (Art. 37.) But being so applied, they will manifestly all act in the *same straight line*. But forces acting in the same straight line cannot be in equilibrium, unless the sum of those acting in one direction be equal to the sum of those acting in the other. Hence, therefore, in the case of *parallel forces*, the condition that the forces should be such as would hold a point at rest, resolves itself into the following:—*that the sum of those tending to turn the system one way, shall equal the sum of those tending to turn it the other\**.—Thus, if the forces  $P_1, P_2, P_3, P_4$ , be respectively 1lb., 2lb., 3lb., 4lb., and the perpendiculars  $Mm_1, Mm_2, Mm_3, Mm_4$ , respectively 6, 5, 2, 1 inches; then the force,  $P_5$ , necessary to hold these in equilibrium must equal the sum of 1lb., 2lb., 3lb., diminished by 4lb.; that is, it must equal 6lb. diminished by 4lb., or 2lb.; and this must be applied parallel to the direction of the rest at a distance from  $M$ , such as, being multiplied by 2, will give a product equal to the difference.

$$(6 \times 1 + 5 \times 2 + 2 + 3) - (1 \times 4); \text{ or } 18.$$

Now, since the product of 2 multiplied by the distance  $Mm_4$  is 18, it is clear that that distance is 9.

\* Thus, in the figure, the forces and directions must be such, that

$$\text{and } P_1 \times Mm_1 + P_2 \times Mm_2 + P_3 \times Mm_3 = P_4$$

These conditions are necessary and sufficient.

## CHAPTER IV.

- 47 Equilibrium of Parallel Forces.      51 The Centre of Gravity.  
 49 If these preserve always their      54 Experimental method of deter-  
*parallelism* in all positions of the      mining it.  
 body to which they are applied,      55—57 Illustrations of the Centre of  
 their Resultant passes always      Gravity.  
 through the *same point* in it.

47. LET us now endeavour to find the *quantity and direction of the resultant of any number of forces acting in directions parallel to one another, but not in the same plane.*—In the first place, let it be observed, that any two parallel lines, being necessarily in the same plane, the directions of any two forces which we may take in a system of parallel forces are essentially so.

48. Let us then, in the first place, find the resultant of two such forces. Then considering this resultant as a new force replacing the first two, let us find its resultant with a third force. This last resultant will be that of the three first forces of the system, and may similarly be combined with a fourth. And thus we may find the direction and the amount of the resultant of all the forces of the system.

49. It is clear that the amount of the resultant force is the sum of the component forces, if they all act to move the body in the same direction. (Art. 46.) For the resultant of the first two is their sum, and that of this resultant and the third force, is *their* sum; that is, the sum of {the three first forces. This again, combined with the fourth force, gives a resultant equal to the sum of the first four, and so on; the resultant of the whole being the sum of all the components.

50. If some of these components, however, act to move the body in a direction *opposite* to the rest, these must be subtracted from the sum of the rest, to obtain the resultant force; as may be shown in the same manner.

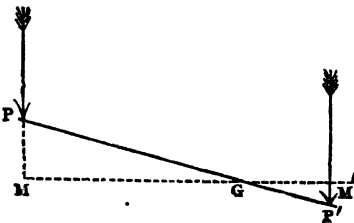

51. *If a body be acted upon by any number of parallel forces, which are such that its position being altered in any way, these forces shall continue to act upon the same points in it, always in directions parallel to their first directions; there is a point in*

*through which the resultant of these forces always passes in every possible position of the body.*

For, let  $P$  and  $P'$  be the points of application of two such forces; join  $PP'$ , and divide it in  $G$ ; so that the products of the forces  $P$  and  $P'$ , by the lines  $GP$  and  $GP'$  respectively, may be equal; then will the products of these forces, by the lines  $GM$  and  $G'M'$ , draw perpendicular on their directions, be also equal. For it is an elementary principle of geometry, that since the triangles  $GMP$  and  $G'M'P'$  are similar, whatever part,  $GM$  is of  $GP$ , the same part is  $G'M'$  of  $GP'$ . Whatever part, therefore, the product of  $GM$  and  $P$  is of the product of  $GP$  and  $P$ , the same part is the product  $G'M'$  and  $P'$  of  $GP'$  and  $P'$ . But the products  $GP$  and  $P$ , and  $GP'$  and  $P'$ , are equal. Therefore, also, the products of  $GM$  and  $P$ , and  $G'M'$  and  $P'$ , are equal; that is, their moments about  $G$  are equal. The resultant of  $P$  and  $P'$  passes, therefore, through  $G$ . (Art 42.) And this is true, whatever be the position of the line  $PP'$ , in reference to the directions of the forces  $P$  and  $P'$ . Whatever position, therefore, this line may, in the motion of the body, be made to assume with respect to those forces, their resultant will *always* pass through the same point,  $G$ , in it.

Now, a point through which the resultant of the first two forces *always* passes being thus found, let this point and the point of application of the third force be joined. And the resultant of the first two forces being supposed to replace those forces, let a point, through which the resultant of this resultant and the third force of the system *always* passes, be found as before. The point so found will be one through which the resultant of the first three forces *always* passes. And, by continuing this operation, a point through which the resultant of all the forces of the system *always* passes, may be ascertained.

52. Now, the forces with which the parts of all bodies at the earth's surface tend to descend, may be considered *parallel* to one another; since they converge towards a point, the earth's centre, whose distance is infinite, as compared with the distances of the parts of these bodies themselves. Hence every such body may be considered as acted upon by a system of parallel forces whose resultant may be found; and these forces, in all positions of the body, act upon the same points in it, in directions parallel to their first direction; there is, therefore, in each such body a point through which the resultant always passes, in whatever position it is placed. That point is called *the centre of gravity of the body.*

The centre of gravity, therefore, of a body is a point through

which the resultant of the weights of its elements always passes, in every position of the body. If the whole of these weights could be extracted from them and concentrated in this point, the parts of the mass still retaining their volume and solidity, the same effects would, under all circumstances, be produced.

53. Although the process explained in Art. 51, is sufficient to assure us of the existence of a point in all bodies possessing the properties of the centre of gravity, yet it does not enable us to determine the *actual position* of that point. And manifestly for this reason: that the points of application of the gravity of a mass being infinite in number, and infinitely near to one another, that process must be infinitely repeated to bring us to any result; and the divisions, which it supposes, must be made in lines which have no appreciable lengths. The position of the centre of gravity may, however, always be fixed upon by the methods of the integral calculus. In a great number of cases its position may, also, be determined by a much easier process, as will be shown hereafter, and the following *experimental* method is applicable to all.

54. Let the body be suspended by a string  $AP$ , from any point in it,  $P$ ; and let  $PM$  be the direction which a plumb-line would take hanging freely from this point. Now the only forces by which it is acted upon, are the weights of its different parts and the tension of the string in the direction  $PA$ . Also the former may be replaced by their resultant. The body will then be acted upon by *two* forces only, viz., the resultant of the weights of the different parts of the mass, and the tension of the string. And, since it is in equilibrium, these are in opposite directions, and in the same straight line. The resultant of the weights of the parts of the body acts, therefore, in the direction of the line  $PM$ . But this resultant passes always through the centre of gravity. The centre of gravity is, therefore, in the line  $PM$ . Having marked the direction of  $Pp$ , suspend the body from any other point,  $Q$ . It may be shown, as before, that when it rests, the centre of gravity is in the line  $QM$ . It is, therefore, in both the lines  $QM$  and  $Pp$ . These lines, therefore, intersect; and the centre of gravity is in their intersection,  $G$ .

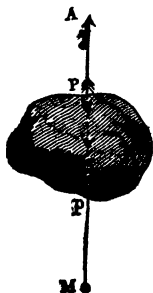

55. A body, when placed upon a horizontal plane, will fall over, unless its centre of gravity be above its base. For the forces which impel the body downward being equivalent to a single vertical force, acting through that point, cannot be sustained unless the plane supply a resistance in a direction opposite to that force; which it manifestly cannot, unless this direction pass through the base of the body.

(Fig. 1.)

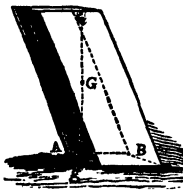

(Fig. 2.)

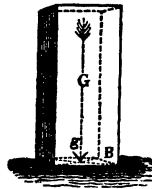

Thus if  $g$  be the centre of gravity of either of the masses represented in the accompanying figures; the forces acting upon that mass are equivalent to a single force acting in the direction of the vertical  $g g$ , and cannot be sustained by the resistance of the plane  $A B$ , unless that single force can be so sustained; that is, unless the plane can supply a resistance in a direction opposite to  $g g$ ; but this it manifestly cannot, unless  $g g$  pass through  $A B$ . In fig. 1, therefore, the solid will stand; in fig. 2, it will fall over. If attention be paid to this fact, buildings may be constructed so as to stand safely, although they lean considerably from the vertical. Thus there is to be seen at Pisa, a tower called the Hanging Tower\*, which so far inclines from the

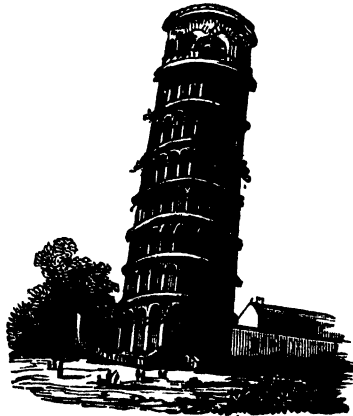

\* The dimensions of this tower contract as you ascend it, and the thickness of its walls is greatly less at the top than at the bottom. Both these causes have a tendency to bring its centre of gravity below the middle point in the height of the tower; and thus, the vertical through that point, further within the boundary of the base.

vertical as to fill strangers with a terror lest it should fall. The vertical line through its centre of gravity does not, nevertheless, fall without the boundary of its base, and it stands firmly.

56. It is not necessary to the equilibrium of a solid body, resting upon a horizontal plane, that the vertical through its centre of gravity should intersect that plane at some point where it is actually in contact with the body. All that is requisite is, that the direction of this vertical should be such that the pressures on the various points of the surfaces in contact *may* have for their resultant a force in a direction opposite to that line. Now this is manifestly possible if several distinct portions of the body be in contact with the plane, and the vertical from the centre of gravity lie *between* them. Thus in the accompanying figure, there will be an equilibrium if  $Gg$  lie between the surfaces of contact  $A$  and  $B$ . And, in the tripod, if it lie between the three points  $A B C$ .



And, generally, if we draw lines joining the extreme points where a body is in contact with the plane on which it rests, the area included within these lines is virtually the base of the body, and there will be an equilibrium, if the vertical through the centre of gravity intersect the horizontal plane any where within this area.

57. The human body is virtually supported upon a base whose boundaries are the outside edges of the feet, and lines joining the heels and toes: and every change in its position is governed by the law, that its centre of gravity shall lie immediately above some point in this narrow base. The motion of any one portion of the body is thus always accompanied by the motion of some other portion in the opposite direction, and thus each action of every part requires an appropriate attitude of the whole. In that wonderful selection of attitudes by which we bring about this nice adjustment of the weight of the body over its base, we cannot, nevertheless, be



said to exercise any skill, each position being, for the most part, taken up instinctively and unconsciously. The adaptation of each attitude with the *least* possible displacement of the body, constitutes what is called *grace* of movement and position; and in the knowledge of the attitudes appropriate to different kinds of action, consists much of the skill of the painter and statuary. Thus, in the beautiful statue of the *Flying Mercury*, of which the accompanying figure is a sketch; the god being in the act of bounding from the earth, his body and left arm are thrown forward; and, with them, the centre of gravity is carried beyond the vertical, passing through the extremity of the right foot, on which the figure rests. To bring it into that vertical again, the sculptor has thrown the left leg and right arm back; and thus the statue assumes a position of stability, into which the human figure would involuntarily throw itself, under the same circumstances.

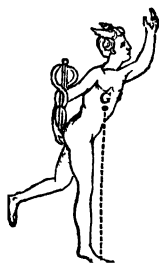

58. A man who supports a load, so adjusts its position and the attitude of his body, as that, the resultant of the weights of these, shall fall within the area spoken of before, as that on which he supports himself. Thus a porter, (fig. 1,) bearing a load upon his back, so inclines himself forward as to bring the common centre of gravity,  $g$ , of his body and the load, within the area bounded by his feet. This point  $g$  lies in the line joining the centres of gravity,  $G$  and  $H$ , of his body and the load; and its position is such that  $gG$  multiplied by the weight of the former equals  $gH$  multiplied by that of the latter. (Art. 45.) If he stood upright, as in fig. 2, it is clear that (although the weight of his load bore only a small proportion to that of his body,) the vertical through  $g$  would intersect the ground beyond his heels, and he would fall backwards. All this every porter knows well enough by experience; and thus in taking his load on his shoulders he inclines himself forwards, that he may bring the resultant, of its weight and that of his body, within the prescribed limits. If he can in any way distribute the parts of his load so as to vary its external form, the shape he selects is the flattest possible, that he may bring

(Fig. 1.)



of his body,)

(Fig. 2.)





its centre of gravity as near as he can to the vertical, passing through the centre of gravity of his body, and produce an equilibrium with the least possible inclination.

(Fig. 1.)



A weight carried before the body, produces the contrary effect, causing it to be thrown back. Thus, if the tray which the woman carries before her, in the accompanying figure, contain any considerable weight, the point  $g$  will be brought so far forward as to lie beyond her toes, and she will then inevitably fall. She avoids this, by throwing the upper part of her person back, as in fig. 1, and she inclines

her arms backwards, resting them upon her sides. Again, in stooping to place a weight upon the ground, her position necessarily throws the head and shoulders forwards. To compensate this, the rest of the body is bent backwards, beyond the line of the heels: and this, the more, as the weight to be deposited is greater, and the position more curved. Still, in stooping, the line of gravitation is necessarily thrown much more forward, than in any of the upright positions of the body; and accordingly, it is in this position

(Fig. 2.)



that the body is most likely to be overthrown.

For reasons analogous to the above, stout persons incline the upper part of the body as far back as possible. A woman



carrying a child on one arm, inclines her body in the opposite direction; and thus brings the common centre of gravity of herself and the child above her feet. A person carrying a package on one shoulder, or carrying a water-bucket in one hand, leans the other way. But a nurse carrying children on

each arm, or a water-carrier buckets in each hand, stands upright.

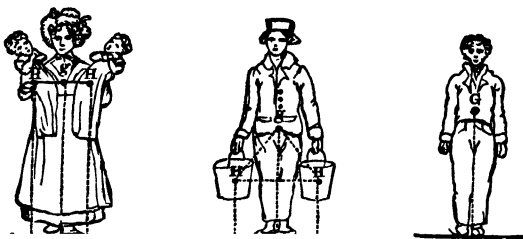

59. When a man stands upright, the vertical through his centre of gravity falls in the middle, between his feet. If, therefore, he lift one of them, this line will lie wholly without the area covered by the other foot, and he must fall. To avoid this, at the same time that he lifts his foot, he inclines his body towards the opposite side, and thus keeps his centre of gravity above the narrow base on which he has to support himself, when standing on one leg. In walking, a man thus supports himself alternately upon his feet; he is, therefore, seen perpetually to move the upper part of his body from one side to the other.

60. *The centre of gravity of a straight line of uniform thickness, a metal rod, for instance, is in its middle point.* For,



—  
A

suppose the rod  $A B$  to be divided into two equal parts in the point  $G$ , and let  $g$  and  $g'$  be the centres of gravity of these parts respectively. Now since the parts  $G A$  and  $G B$  are equal and similar in every respect, it is clear that their centres of gravity  $g$  and  $g'$  are similarly situated; so that if the part  $G B$  were turned over, and made to coincide with  $G A$ , the points  $g$  and  $g'$  would coincide.  $G g$  is therefore equal to  $G g'$ . Now the resultants of the forces acting on  $G A$  and  $G B$ , passing always through  $g$  and  $g'$  (Art. 52), also these resultants being always equal to one another; their resultant must always pass through the middle point  $G$  between  $g$  and  $g'$  (Art. 42). And this resultant is that of the forces acting on the whole line  $A B$ . Since then the resultant of the weights of the different parts of a straight line passes always through its middle point; such a line will balance in every position, if suspended by its middle point.

V 17226

61. *Any geometrical figure which is symmetrical with regard to a certain line, has its centre of gravity in that line.*

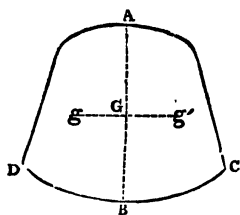

For, first, suppose the figure to lie all in the same plane. Let it be represented by  $A D B C$ , and let it be symmetrical about  $A B$ , so that the parts  $A D B$  and  $A C B$  may be equal and similar in every respect. Take  $g$  and  $g'$  the centres of gravity of these parts. Then, as before, if the part  $A D B$  be turned over and laid upon  $A C B$ ; the figures themselves coinciding, their centres of

gravity  $g$  and  $g'$  will coincide. Therefore, joining  $g g'$  which intersects  $A B$  in  $G$ ,  $G g$  and  $G g'$  are equal. Also the forces acting at  $g$  and  $g'$ , being the weights of the equal figures  $A D B$  and  $A C B$ , are equal. Their resultant passes, therefore, always through  $G$ , (Art. 42,) which point is in  $A B$ . That is, their centre of gravity is in  $A B$ .



62. If a figure, as above, have two lines of symmetry; its centre of gravity is in both of them, and lies, therefore, in their point of intersection, that being the only point which is common to both lines. Thus, a parallelogram being symmetrical about its diagonals, its centre of gravity lies in their intersection.

63. A figure is said to be symmetrical about a point, when it is symmetrical about all lines drawn through that point. Such a point is, therefore, manifestly the centre of gravity of the figure. Thus a circle and an ellipse, being symmetrical about their centres, have their centres of gravity in those points. And for this reason, a wheel being supported upon an axis passing through its centre, rests into whatever position it is turned round upon it.

64. If we suspend a body freely by one extremity of its line of symmetry, it will not rest until that line is in the vertical. For the centre of gravity is in that line, and it has been shown, that a body suspended freely cannot rest, until its centre of gravity is in the vertical passing through the point of suspension.



The frames of pictures are commonly of an oblong form. Now an oblong is a symmetrical about a line joining the middle points of two of its opposite sides. If, therefore, it be suspended from the middle point of one of its sides, it will hang with that line vertical, and, therefore, its

two ends which are parallel to that line will also be vertical.

65. A curved surface, or a solid, is said to be symmetrical about a certain line, called an axis; when being intersected by a plane perpendicular to that axis, the section is symmetrical, and its centre of symmetry lies in that axis. Hence, therefore, the solid or surface, being intersected by a series of such planes exceedingly near to one another; the centres of gravity of the thin slices, or rings, between each two adjacent planes, are in the axis of symmetry: and the whole solid or surface being made up of these, the centre of gravity of the whole is in that axis. If, therefore, a solid have two axes of symmetry, since its centre of gravity lies in each of these, they must intersect, and that point lie in their intersection. Thus the figure, called a parallelo-pipedon, represented in the accompanying diagram, which is contained by six planes, of which each two that are opposite are parallel, and which is symmetrical about a line joining any two of its opposite angles; has its centre of gravity in the intersection  $G$  of two such lines, and however it be suspended, that point will lie when it rests immediately beneath its point of suspension.

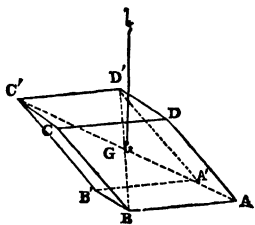

A sphere is symmetrical about its centre; that point is therefore its centre of gravity. A cylinder is symmetrical about its axis, and about a line bisecting its axis perpendicularly. The bisection of its axis is therefore its centre of gravity.

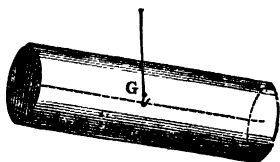

66. We shall now proceed to consider the positions of the centres of gravity of certain bodies which are not symmetrical about a point. *To find the common centre of gravity of any two lines  $AB$  and  $A'B'$ .* Bisect  $AB$  and  $A'B'$  in  $G'$  and  $G''$ . These points are then their centres of gravity, and the resultants of the forces which act upon them, pass always through those points. These resultants are the weights of the lines  $AB$  and  $A'B'$ . Join therefore,  $G'G''$ , and take a point  $G$ , so that  $G'G \times$  (weight of  $AB$ ) may equal  $GG'' \times$  (weight of  $A'B'$ ). Then will the resultant of the forces acting at  $G'$  and  $G''$ , that is, the resultant of all the forces on

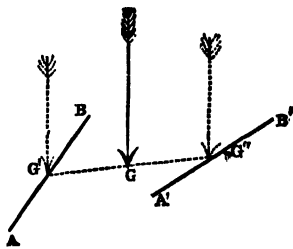

the system; act, in every position in which it can be placed, through  $g$ . (Arts. 42 and 51.) And  $g$  is the centre of gravity.

67. To find the centre of gravity of three lines forming a triangle.—Take half the sum of the weights of  $AC$  and  $BC$ , and half the sum of those of  $AB$  and  $BC$ , and find a point  $g'$  in  $BC$ , so

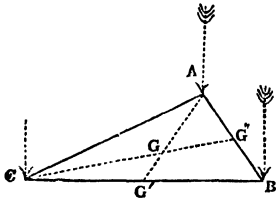

that the first sum multiplied by  $g'c$  shall equal the second multiplied by  $g'B$ . And find a second point  $g''$  by a similar process in  $AB$ . Join  $Ag'$  and  $Cg''$ , and the point  $g$  is the centre of gravity to the whole.

For the lines have the same centres of gravity as though their weights were divided, each into two equal parts, and collected in their extreme points. Suppose them to be so collected in  $A$ ,  $B$ , and  $C$ . The centre of gravity of the weights collected in  $B$  and  $C$  will then be at  $g'$ . Therefore, the centre of gravity of all the weights collected in  $A$ ,  $B$ , and  $C$ , will be in the line joining  $A$  and  $g'$ . Similarly, the centre of gravity of all the weights may be shown to be in the line  $Cg''$ . Since, therefore, it is in both these lines, it must be in their intersection  $g$ .

68. To find the centre of gravity of a thin plate or lamina, in the form of a triangle.—Let  $ABC$  be the triangle. Bisect its side  $BC$  in  $M$ , and join  $AM$ . Suppose the triangle to be divided by lines parallel to  $BC$ , and exceedingly near to one another. Let  $pQ$  be the portion included between any two such lines. The centre of gravity of  $pQ$  is in its middle point  $q$ . Now the bisection  $q$  of  $pQ$ , and of every other similar

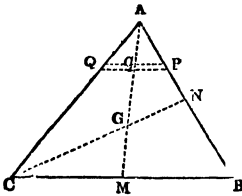

element, is in the line  $AM$ . Each element has, therefore, its centre of gravity in the line  $AM$ ; and the centre of gravity of the whole triangle is, therefore, in that line.

In the same manner, if  $AB$  be bisected, and  $CN$  joined; it may be shown, that the centre of gravity of the triangle is in that line. It is, therefore, in  $G$ , the intersection of  $AM$  and  $CN$ .  $AG$  is equal to two-thirds of  $AM$ .

69. To find the centre of gravity of a pyramid  $ABCD$ ; intersect it by planes,  $pQR$ , exceedingly near to one another, and parallel to either face  $BCD$ . Take  $g'$ , the centre of gravity of this face, and join  $Ag'$ . This line intersects all the sections of the pyramid in points similarly situated in each, and it passes

through the centre of gravity of the section adjacent to  $BCD$ , therefore, it passes through the centre of gravity of each other section; and the centre of gravity of the lamina lying between any two sections, is in it. Now the whole pyramid is made up of such laminae. The centre of gravity of the whole pyramid lies, therefore, in  $AG'$ . Similarly, if we take  $G''$ , the centre of gravity of the face  $ABC$ , and join  $DG''$ , the centre of gravity of the whole pyramid will lie in this line. It is, therefore, in the intersection  $G$  of the lines  $DG''$  and  $AG'$ .  $AG$  equals three-fourths of  $AG'$ .

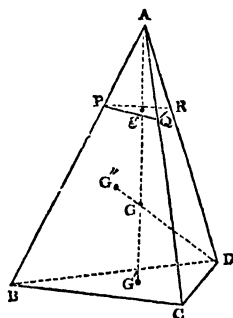

CHAPTER V.

The Resistance of a Surface not exclusively in a Direction perpendicular to that Surface.—Fric-

tion.—The Limiting Angle of Resistance.—Illustrations.

70. WE shall, for the present, suppose, that the parts of a solid body cohere, so firmly, as to be incapable of separation, by the action of any force which may be impressed upon them. The limits within which this supposition is true, will be discussed hereafter. The question we are about to enter upon has reference to the *direction* in which the surface of one body can be pressed upon that of another so as not to slip along it.

71. Let us suppose a mass  $A$  to be pressed upon another  $B$ , by means of a force  $P$ , acting in a direction *perpendicular* to the common surface of the two bodies. And let a second force  $Q$  act also upon it, in a direction *parallel* to this surface. Then, since the forces  $P$  and  $Q$  act in directions perpendicular to one another, they manifestly cannot counteract one another, and one would expect, that the body should move in the direction of the second force. This, however, is not found to be the case. So long as the force  $Q$  does not exceed a certain limit, no motion ensues. Some new force  $R$ , therefore, has been produced in the system counteracting the force  $Q$ . That force is called friction. It acts, always, in a direction parallel to the surfaces in contact, and



is always for surfaces of the same nature, the same fraction, or part, of the force  $P$  by which these are pressed together, whatever be the amount of that force, or whatever the extent of the surfaces in contact. This fraction is called the co-efficient of friction. Whilst it is thus the same for the same surfaces, whatever be the extent of the surfaces or the force with which they are pressed together, it is different for different surfaces. Thus when the surfaces are both of brass, the co-efficient of friction is represented by the fraction  $\frac{1}{5.7}$ ; whilst, if one be of brass, and the other of steel, it is  $\frac{1}{7.5}$ .

72. Let us now suppose the force  $P$  instead of having its direction perpendicular to the surfaces in contact, to have been

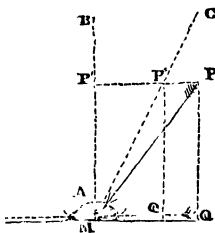

impressed obliquely. Draw  $MP'$  perpendicular to these surfaces from the point  $M$  where the direction of  $P$  meets them. Draw  $PP'$  perpendicular to  $MP'$ , and complete the parallelogram  $PQMP'$ . The force  $P$  being then represented by the line  $PM$  is equivalent to two others represented by  $P'M$  and  $QM$ . The former is that by which the surfaces are pressed together. Their actual friction upon one another is, therefore, a certain given fraction of this force  $P'M$ . Take  $MQ'$  equal to this given fraction of  $P'M$ , complete the parallelogram  $P'Q'M$  and draw its diagonal  $P''M$ . Since then  $MQ'$  represents the friction of the body upon the plane, or the force called into action by  $PM$ , which opposes the motion of the body. Since, moreover,  $QM$  represents the force tending to produce motion in it upon the plane; it follows that the body will move or not according as  $QM$  is greater or less than  $Q'M$ , or as  $PP'$  is greater or less than  $P''P'$ , or as the angle  $PMB$  is greater or less than  $CMB$ .

This angle  $CMB$  may be called the limiting angle of resistance. It depends upon the co-efficient of friction, having for its tangent the fraction  $\frac{P'P''}{P'M'}$  or  $\frac{MQ'}{P'M}$ , which is equal to that co-efficient\*. It is, therefore, the same for surfaces of the same nature, whatever be the actual amount of the impressed force  $P$ ; but different for different surfaces.

73. From the above, then, it appears that force impressed

\* The properties of the limiting angle of resistance were first given by the author of this work in a paper published in the fifth volume of the Cambridge Philosophical Transactions.

upon the surface of a solid body, at rest, by the intervention of another solid body, will be destroyed, whatever be its direction, provided only the angle which that direction makes with the perpendicular to the surface do not exceed a certain angle, called the limiting angle of the resistance at that surface. And that this is true, however *great* the force may be. Also, that if the direction of the force lie without this angle it cannot be sustained by the resistance of the surfaces in contact, and that this is true, however *small* the force may be.

In works upon mechanics, the direction in which the resistance of a surface is exerted, is usually stated to be that of the perpendicular at the point of contact. This is altogether a philosophical abstraction, introduced originally to simplify the conditions of equilibrium, and diminish the difficulties which attend the theory of statics. It is much to be doubted, whether, in the present state of science, any of the reasons for introducing an hypothesis, directly opposed to the facts of the case, remain. The data being false, the results are, of course, opposed to experience; and all propositions, thus established, are subject to *corrections* for friction.

On the whole it appears, that whereas surfaces perfectly polished and free from friction, (if such existed,) could destroy by their resistance, only such forces as were impressed in directions perpendicular to their surfaces; bodies, such as are actually found in nature subject to friction, destroy all forces incident at any angle with the perpendicular less than the limiting angle of their resistance. In the following treatise, the resistance of a surface will, therefore, be considered as exerted equally in any direction within that angle.

74. In walking, the weight of the body is thrown at each step upon the fork of the legs, and their tendency to separate is resisted by the friction of the feet against the ground. As long as the inclination of the legs does not exceed the limiting angle of resistance, the feet will not slip, whatever be the weight of the mass they support, or the muscular force with which they are brought to the ground. Most of those substances which form the surface of the earth are, in their nature, hard and rough, having a large limiting angle of resistance. So long as the ground on which we tread is a horizontal plane, we may incline our legs at a very considerable angle from their natural position, without danger of slipping, as may be sufficiently observed in running or leaping. But if the ground be inclined, so that the direction in which the weight of the body is sustained by the legs is already inclined to its surface, a very slight fur-



ther inclination of them, is sufficient to bring the direction of the pressure without the limiting angle, and cause the body to slip. In cases where the limiting angle of resistance is small, a slight inclination is sufficient to cause a fall. Thus, a man's legs readily slip from under him when he walks upon ice; the limiting angle of resistance between ice and the leather of his shoes being small; he is, therefore, careful to take short steps, so as to incline his legs at the least possible angle. On the same principle he would fall still more readily, if shod with iron.

75. If his feet be supported upon the edge of a thin piece of iron, like the iron of a skate, the portion of the surface of the ice which ultimately sustains the pressure being exceedingly small, yields, and the iron sinks into it. Its motion sideways is then opposed by a ridge of the abraded ice, extending throughout its whole length; and lengthways by a similar ridge, whose length is, however, only equal to the thickness of the skate-iron. His feet, therefore, readily slip in the direction of their length; but there is little danger of their yielding laterally.

76. The muscular force which a man exerts in walking is the same at every step, being wholly destroyed by the resistance of the earth when one foot comes to the ground, and reproduced when the other foot is raised: a portion may be considered to be exerted in a vertical direction, and another horizontally; the latter is wholly resisted by the friction of the earth.

77. There is scarcely any thing which would produce greater inconvenience to us than the loss of that friction, which we complain so much of when we find it robbing us of the force which we apply to artificial uses. Yet, were it not for the existence of some principle, acting everywhere and at every instant to destroy the forces which we are ourselves perpetually producing in excess, and which are generated around us, when they have produced their effect, this world of ours would scarcely be habitable. Were there, for instance, no friction, it would be impossible for a man to move from any position in which he might be placed, without the aid of some fixed obstacle by means of which he might push or pull himself forward. And were there no horizontal power of resistance in the ground on which he treads to destroy the forward motion which he gives himself at every step, he would retain that motion until some obstacle interposed to destroy it; so that the principal part of his time would be spent in oscillating about between the obstacles, natural or artificial, which the earth's surface presented to his motion; an oscillation which would be common to all the objects, animate or inanimate, about him. The slightest

wind would sweep him before it; the slightest inclination of his body would bring him to the ground: every thing he put out of his hand would start away from him, with the lateral force which he could not fail to communicate to it, in releasing his hold. If he attempted to sit down, his chair would slip from under him; and when he sought to lie down, his couch would glide away from him. He would, in all probability, be driven to forsake the land, and dwell upon the waters as the more stable element.

78. The following table contains a list of the principal substances whose friction upon one another has been determined; annexed to each is the constant fraction which the friction is of the insistant pressure; and beyond it the limiting angle of resistance, corresponding to this fraction.

Nature of Surfaces in Contact.	Co efficient of Friction.	Limiting Angle of Resistance.
Steel and Ice ....	$\frac{1}{69.81}$	0 49
Ice and Ice ....	$\frac{1}{7.73}$	1 35
Hard Wood and Hard Wood ....	$\frac{1}{7.38}$	7 43
Brass and Cast Iron....	$\frac{1}{7.11}$	8 0
Brass and Steel....	$\frac{1}{7.20}$	7 54
Soft Steel and Soft Steel ....	$\frac{1}{6.85}$	8 18
Cast Iron and Steel ....	$\frac{1}{6.62}$	8 36
Wrought Iron and Wrought Iron ....	$\frac{1}{6.26}$	9 5
Cast Iron and Cast Iron ....	$\frac{1}{6.12}$	9 17
Hard Brass and Cast Iron ....	$\frac{1}{6.00}$	9 27
Cast Iron and Wrought Iron ....	$\frac{1}{5.87}$	9 40
Brass and Brass ....	$\frac{1}{5.70}$	9 57
Tin and Cast Iron ....	$\frac{1}{5.59}$	10 8
Tin and Wrought Iron ....	$\frac{1}{5.53}$	10 15
Soft Steel and Wrought Iron ....	$\frac{1}{5.28}$	10 43
Leather and Iron ....	$\frac{1}{4.00}$	14 2

Nature of Surfaces in Contact.	Co-efficient of Friction.	Limiting Angle of Resistance.
Tin and Tin ....	$\frac{1}{3 \cdot 78}$	14 49
Granite and Granite ....	$\frac{1}{3 \cdot 30}$	16 52
Yellow Deal and Yellow Deal ....	$\frac{1}{2 \cdot 88}$	19 9
Sand Stone and Sand Stone ....	$\frac{1}{2 \cdot 75}$	19 59
Woollen Cloth and Woollen Cloth ....	$\frac{1}{2 \cdot 30}$	23 30

*Note.*—The above Table is calculated from experiments made by Mr. Rennie, under pressures of thirty-six pounds to the square inch. The co-efficients of friction would be somewhat less for greater, and greater for less, pressures. The constant ratio of the pressure to the friction, although exceedingly near to the true law of resistance, does not, therefore, it would seem, *accurately* enunciate that law.

## CHAPTER VI.

### The Inclined Plane.

- 79 The Equilibrium of a Mass placed upon an Inclined Plane, and not supported otherwise than by the Resistance of the Plane.
- 80 Of a Mass partly supported by another Force acting in any direction upon it.
- 81 The best Direction of this Force so that it may be upon the point of giving Motion to the Mass upwards.
- 83 The Equilibrium of a Cylinder on an Inclined Plane.
- Independent of Friction.  
The Carriage Wheel.

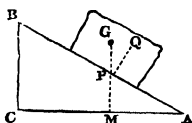

79. LET us suppose a heavy mass, whose centre of gravity is  $G$ , to be placed on an inclined plane  $AB$ ; and let it be required to determine under what circumstances this mass will just be upon the point of slipping down the plane.

Draw the vertical line  $GM$ : the whole pressure of the mass may be supposed to act in the direction of this line; and this pressure will just be destroyed by the resistance of the surface of the plane, when the angle  $GPQ$ , which  $GP$  makes with the perpendicular  $PQ$ , is equal to the limiting angle of resistance. (Art. 73.) Now, it is easily seen that the angle  $GPQ$ , is equal to the angle  $BAC$ . A mass of any substance will, therefore, just be sustained on an inclined plane, without slipping, when the inclination of the plane is equal to the limiting angle of the resistance of the surfaces in contact.

80. If the mass, besides the resistance of the surface of the plane, be sustained by a force, equal to the weight  $n$ , acting in the direction  $QP$ ; we may determine under what circumstances it will remain at rest, by producing  $PQ$  to meet the vertical  $G\Pi$ , through the centre of gravity, in  $a$ , and taking  $ad$  and  $ab$ , to represent the weights of  $M$  and  $N$ . For, completing the parallelogram  $abcd$ , so as to have  $ad$  for its diagonal;  $ac$  will represent the quantity and direction of the force requisite to sustain the two others in equilibrium. (Art. 21.) If this direction be not inclined to  $Ac$ , beyond the limits of resistance, the requisite force will be supplied by the resistance of the plane, and the body will rest. If it lie beyond that limit, the resistance of the plane is inadequate to supply the force required to sustain the other two; and the mass will descend.

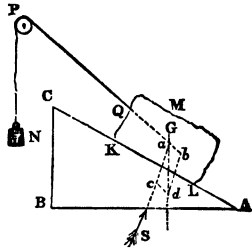

If the direction of the force  $ac$  be upwards, the tendency of the mass will be to slide up the plane, instead of down it: and provided  $ac$  be inclined in this direction, just within the limit of resistance, motion will be upon the point of taking place.

81. Now let us consider in what direction the force  $N$  must be made to act, so that it shall preserve the equilibrium under these circumstances, and be the least possible force that will do so. Take  $ad$  as before, to represent the weight of the mass, and draw  $ac$  in the limiting direction of the resistance upwards. (Art. 73.) Through  $d$  draw  $db$  parallel to  $ac$ . Then any line  $ab$ , drawn from  $a$  meeting  $db$ , will represent, in quantity and direction, a force, such as would just maintain the equilibrium (Art. 21); for drawing  $dc$  parallel to  $ab$ , any such force, together with the force  $ad$ , will have for their resultant  $ac$ , which is in the direction in which it will just be destroyed by the resistance. Now of all these lines

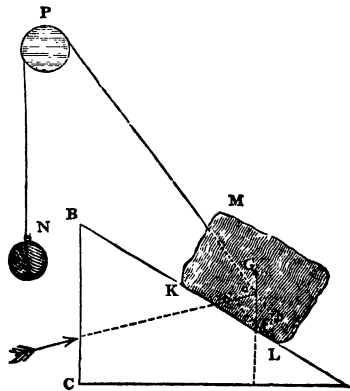

which can be drawn from  $a$  to  $b d$ , that which is perpendicular to it is the least. That line is, therefore, in the direction of the least force, and represents it in magnitude. It is in this direction that a given force, the force of a horse for instance, would be exerted with the greatest advantage to drag the mass upwards.

82. There is a further condition necessary to the equilibrium, namely, that the resultant of the forces acting upon the mass should pass through that portion of its surface  $\kappa L$ , by which it touches the plane. (Art. 55.) It will manifestly be upon the point of turning over, if  $a c$ , being produced, pass through either of the points  $\kappa$  or  $L$ .

83. If the body rest upon the plane, only by a single point, the resultant must pass through that point. Suppose it a cylinder,

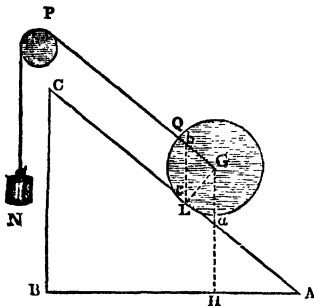

whose centre is  $g$ , and let the force  $N$ , applied to the point  $G$ , be that which will just hold it in equilibrium. Then since two of the forces holding the mass at rest, (namely, the force  $N$ , and the weight of the mass itself,) act through the point  $G$ , therefore, the resistance which is equal to their resultant, acts through the same point. (Art. 22.) But this resultant acts

also through  $L$ . Joining, therefore,  $g L$ , it acts in the direction  $L G$ . If the force  $N$  be ever so little increased, the resultant will be brought within the angle  $L G P$ ; and if the mass be moveable about  $G$ , it will thus be made to roll up the plane.  $L G$ , being a radius of the cylinder, is essentially perpendicular to the plane, which it touches in the point  $L$ . In this particular case, therefore, its resistance is exerted only in a direction perpendicular to its surface, so that the conditions of the equilibrium are not affected by the friction of the surfaces. Thus a carriage-wheel might, if there were no obstacle in its path, and no friction at its axle, be made to move up an inclined plane, by means of any force however small, provided it were greater than that which would be necessary to support it upon the plane.

84. Take  $G a$  to represent the weight of the mass, and draw  $a c$  parallel to  $G P$ , and  $c b$  parallel to  $a G$ . Then  $G b$  will represent the magnitude of the force  $N$ , necessary to produce equilibrium, on the same scale on which  $G a$  represents the weight, and  $G c$  the resistance.

85. If  $G P$  be parallel to  $A C$ , (see fig. above,)  $a c$  will coincide

with  $aL$ ; and\* if, in this case, we take  $AC$  to represent the weight of the mass supported,  $BC$  will, on the same scale (or to the same unit,) represent the weight  $N$ , necessary to support it, and  $AB$  the resistance. If  $GP$  be parallel to the base,  $AB$ , of the inclined plane;  $BC$  being taken to represent the weight of the mass  $G$ ,  $AB$  will represent that of the weight  $N$ †. In the first case, dividing  $AC$  into as many units of length, as there are units of weight in  $G$ , so many of these units as there are in  $BC$ , will there be units in the weight  $N$ ; and in the other case, dividing  $BC$  into as many units as there are in the weight  $G$ , the value of  $N$  will be determined by the number of these units in  $AB$ .

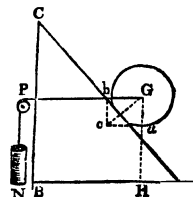

CHAPTER VII.

The moveable Inclined Plane.

86 The circumstances under which it will be upon the point of sliding upon a mass which is pressed against it by given forces.

87 The Wedge.

88 Its angle must not exceed the

limiting angle of resistance.

89 Circumstances under which the Wedge cannot be started by any pressure of the mass into which it is driven on its sides.

90 Examples of the use of the Wedge.

WE have supposed the plane  $CAB$  to be fixed in its position; let us now suppose it to be moveable. The force requisite to hold it at rest, is equal and opposite to the resistance it sustains. That is, it is equal to the force  $ac$ , (fig. page 65,) and in the direction  $sa$ .

86. Let us suppose all the forces which act upon a mass  $M$ , to have for their resultant a force acting in the direction  $pq$ . Produce  $pq$  to  $m$ , and take  $qm$  to represent the resultant force. A force represented in quantity and direction by  $m q$ , will then just hold the plane at rest. Draw  $qn$  perpendicular to  $bc$ . The forces represented by  $mn$  and  $nq$  are then equivalent to that represented by  $m q$ . These would, therefore, hold the plane at rest. But if it be placed with its base  $AB$  upon a horizontal plane, the vertical force,  $mn$ , will be supplied by the resistance of that plane.

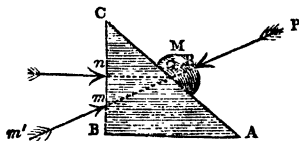

\* By reason of the similarity of the triangles  $g a L$  and  $\Delta C B$ .

† By reason of the similarity of the triangles  $g a c$  and  $\Delta B C$ .

To keep the plane at rest, all that is requisite is\*, therefore, to apply to the back of it  $n$ , a force  $n'n$ , represented in magnitude and direction by  $nq$ .

The angle which  $pq$  makes with the perpendicular  $qr$ , to the surface of the plane, will always equal the limiting angle of resistance, whatever be the force  $n'n$ , applied to the back of the plane, provided the force  $pq$  be supplied by the resistance of some fixed mass, of which  $m$  forms a part, or against which it abuts; and provided the direction of  $nq$  be *without* the limiting angle of friction at  $q$ . For it is manifest that, if the direction of  $nq$  had been *within* the limiting angle of resistance, that force would have been wholly counteracted by the resistance of the mass  $m$ , so that  $pq$  and  $nq$  would have been in the same straight line, and no reaction of the plane  $ab$  on which the body rests would have been necessary to the equilibrium; also, that if the force  $nq$  be *without* the limiting angle of resistance at  $q$ , so that the resistance of  $m$  is insufficient alone to sustain it, *only* so much reaction will be supplied by the plane  $ab$  as is necessary to render it sufficient, or to produce together with  $nq$ , a resultant force  $mq$ , just within the required limits.

If the force  $n'n$  be so far increased as to cause the force  $mq$  to be *greater* than any resistance which the mass  $m$ , or that of which it forms a part, is capable of supplying; the equilibrium will be destroyed, the plane will move in the direction  $mq$ , the reaction of the plane  $ab$  will cease, and by the action of the force  $nq$ , whose direction is supposed to be without the limiting angle of resistance, and which is the only one now acting upon it, the plane will be made to slide along the surface of  $m$ , until its base is again brought in contact with the plane  $ab$ . When thus employed, the action of the plane is precisely similar to that of a wedge.

#### THE WEDGE.

87. LET  $m$  and  $m'$  be portions of a solid, pressed upon the sides of a wedge  $ca c'$ , by equal forces acting in the direction  $pq$  and  $p'q'$ . Take  $qm$  and  $q'm'$  to represent these forces, and resolve them into  $nm$ , and  $qn$ ,  $n'm'$   $q'n$ . Of these,  $nm$  and  $n'm'$  are equal, and act upon the wedge in opposite directions. They therefore destroy one another. The forces  $qn$

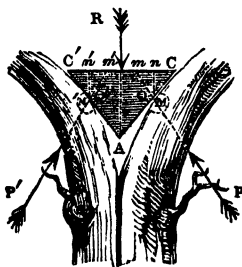

The horizontal plane  $ab$  is supposed to be without friction.

and  $q' n'$  are sustained by a force  $R$ , applied perpendicularly to the middle of the back of the wedge, and equal to their sum. By the last article, it appears that the directions of  $PQ$  and  $P'Q'$  will, under these circumstances, make, with the perpendiculars to the surfaces  $AC$  and  $A'C'$ , angles equal to the limiting angle of resistance. Also that when the forces  $mQ$  and  $m'Q'$  are made to exceed the resistance of  $M$  and  $M'$  the wedge will slip forwards, and thus produce a still further separation of the solid, against which it acts.

88. Returning to the case of a mass held in contact with the surface of an inclined plane, by the resistance of an immoveable obstacle. Let  $RQS$  equal the angle of friction. And draw  $QP$  parallel to the base of the plane. Then, if the angle  $RQS$  be greater than  $RQP$ , the direction of  $mQ$  is within the angle of resistance, and no force, however great, applied to the back of the plane, can cause it to move on the mass  $M$ .

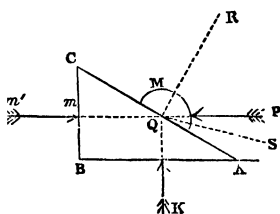

Now the angle  $RQP$  is equal to the angle  $ACB$ . The plane cannot, therefore, be moved, if the limiting angle of resistance exceed that which it makes with its back.

89. Let us now suppose the wedge to be driven, and let us consider the pressure which the substance into which it is driven must exert upon its sides, in order to force it out. Let  $PQ$  be the direction of the resultant of the forces acting upon the face  $AC$ , which being propagated through the mass of the wedge, tends to cause the face  $AC$  to slide upon the surface with which it is in contact. Draw  $QR$  perpendicular to the surface in this point. Then if  $PQR$  be not greater than the limiting angle of resistance, no force with which the mass into which the wedge is driven tends to collapse, can expel it.

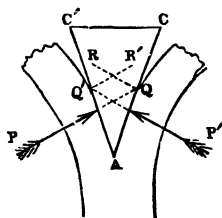

Although we can very well understand how a substance, into which a wedge is driven, may oppose a *resistance*, in any direction, to its motion forwards, yet it is difficult to conceive, how this substance should exert an effort to *collapse*, and to throw it out, otherwise than in a direction perpendicular to the sides of the wedge, especially if it be of a fibrous nature.  $PQ$  being thus supposed perpendicular to  $AC$ , the angle  $CA C'$  will equal  $PQR$ . On this hypothesis, therefore, if the angle of the



wedge be not greater than the limiting angle of resistance, it will remain firmly fixed in the substance into which it is driven.

90. This property of the wedge renders it eminently useful in carpentry. The following may be taken as one out of a vast variety of applications. Suppose it were required to fix two pieces of timber  $AB$  and  $A'B'$  together; and that, either by reason of the greater economy of wooden fastenings, or the liability of the timber to occasional damp, and consequently to

Fig. 1.

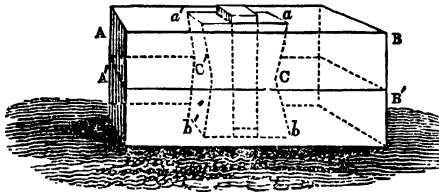

corrosion, by contact with iron, it is desirable to avoid the use of iron bolts. Let two wedge-shaped mortises be made in the timbers, represented by  $acc'a'$  and  $bcc'b'$ ; being of equal size at their smaller extremities. Let the timbers be laid together, these extremities of the mortises coinciding. Let two pieces of hard wood be formed into the shape represented, fig. 2; the

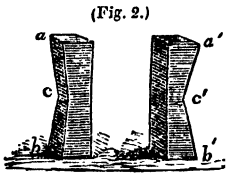

face  $acb$  corresponding with the side  $acb$  of the mortise, fig. 1; but the upper extremity  $a$  being somewhat narrower than  $b$ . Let these two pieces of timber be placed in the mortises, the corresponding faces coinciding. The space between them will then have the form of a wedge, by reason of their being narrower at the top than the bottom. Let a wedge of the proper dimensions be driven in between them. If the angle of the wedge be sufficiently small, no possible force exerted on its sides can start it; no possible force, therefore, can separate the timbers. {This method is used in fixing together the timbers of the immense wooden bridges which have been erected in America.

91. There is scarcely any instrument whose applications are more numerous than those of the wedge. Nails, awls, needles, axes, sabres, &c., all act on the principle of the wedge. As illustrative of the great power of the wedge, it may be stated that ships, when in dock, are easily lifted up by means of

wedges driven under their keels. An engineer, who had built a lofty and heavy chimney for a furnace, found that, after a time, owing to the dampness of the foundation, it was beginning to incline. He succeeded in restoring it to its uprightness by driving wedges under one side\*.

92. The resistance to the motion of a wedge depends, not only upon the angle at its vertex, but on the depth to which it is driven, and, consequently, the extent of surface which sustains its pressure; and further, it depends upon the quantity by which the particles of the mass are displaced: for being elastic, these particles will tend to come together with a force proportional to their displacement. These are all reasons why a wedge is driven with difficulty, when it is driven deep.

The wedge  $\triangle ACC'$  having been driven, by the action of a force  $P$ , a certain distance into a mass whose surface is  $MN$ ; let us suppose a second force  $Q$ , to be made to act upon it, its upright position being otherwise preserved. This force  $Q$  will press the surface  $AC$  against the mass lying between  $M$  and  $M'$ , and being sufficient, it will remove that mass, so that the vertex of the wedge will encounter a new surface  $M'N'$ , parallel to  $MN$ , and may be made

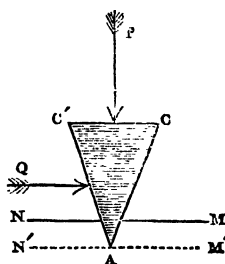

to enter it as before by the action of the force  $P$ . If, instead of acting separately, the forces  $P$  and  $Q$  be made to act together, the effect will be precisely the same, their directions being at right angles to one another. Such is the theory of the common saw. It is formed of a series of such wedges cut in the edge of a thin lamina of steel, and tends, by its weight, perpetually to drive the points of these wedges into the substance on which it acts, and by its longitudinal motion to present a fresh surface continually to their action. When the teeth are small, the portions of matter, lying between each two, are small, and the force requisite to remove each is proportionately small. Thus saws with large teeth are used for soft, and saws with small teeth, for hard substances. The majority of cutting instruments

\* The enormous power of the wedge is principally owing to its being driven by *impact*. The resistance on its sides is of the nature of pressure; and it is a fundamental principle of dynamics, that a pressure, however great, necessarily yields *at the moment of impact* to an impinging force, however small. The momentary separation of the mass thus produced is rendered permanent, by the forward motion of the wedge.

act as saws; the asperities produced in their edges, by sharpening, acting as so many wedges. To this class belong scythes, table-knives, sabres, &c.

93. In sawing stones, nothing but a simple blade of soft metal is used; the small angular particles of the substance to be sawn, or the powder of some harder substance mingled with them, are, by the action of this blade, moved backwards and forwards on the stone, and act as so many wedges in cutting it. The hardest stones may, by this means, be sawn asunder. For cutting granite, emery is used. In cutting glass, emery is mingled with water, and made to drop upon a sharp-edged wheel, put rapidly in motion; and in engraving gems, diamond-powder, mingled with water, is made to drop on the point of a slender piece of soft iron, revolving with great velocity, upon its axis. The glass or gem to be engraved, being held, under these circumstances, against the instrument, is cut with wonderful facility, by the action of the minute wedges into which the crystallized substances used, form themselves, when powdered. Files are commonly rods of steel, having their surfaces studded with small wedges, and acting on a principle precisely analogous to that of the saw.

The carpenter's plane is no other than a wedge, which, instead of being formed like the teeth of a saw, in a slender lamina of metal, is of considerable width, and has its axis slightly inclined, that the longitudinal motion which is given to it may drive it into the substance to be planed. Its action is otherwise precisely analogous to that of a tooth of the saw.

## CHAPTER VIII.

The Lever.	104 The Balance used for determining the Standard Bushel.
95 Conditions of its Equilibrium.	105 The Bent Lever Balance.
96 Reaction of its Fulcrum.	106 On Compound Levers.
97 Applications of the Lever.	107 The Weighing Machine.
99 Effect of the weight of the Lever.	108 The Fulcrum of a Lever.
100 The Roman Statera.	109 The Axis of a Lever.
101 The Steelyard.	110 The Carriage Wheel.
102 The Danish Balance.	
103 The Common Balance.	

THE lever is an inflexible rod, which rests by one point against an immoveable obstacle, and sustains a force called the *resistance* at one of its extremities, by the action of another force called the *power* applied at the other.

94. Levers are of three kinds. In the first kind, fig. 1, the power  $P$  and resistance  $R$  are applied on opposite sides of

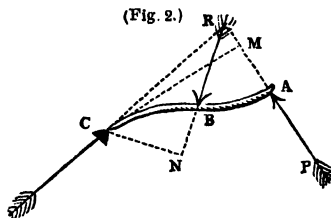
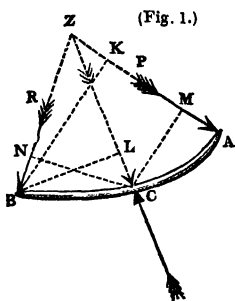

the fulcrum  $C$ . In the second, fig. 2, the resistance  $R$  is between the power  $P$  and the fulcrum. In the third, fig. 3, the power  $P$  is between the resistance  $R$  and the fulcrum.

95. In all these the equilibrium of the power and resistance, if we conceive the lever to be without weight, is governed by the following simple law. That the power multiplied by the perpendicular from the fulcrum upon its direction, shall equal the resistance multiplied by the perpendicular upon its direction. This law is easily deduced from a general principle which we have established. (Art. 35.) It is this:—"When any number of forces, acting in the same plane, are in equilibrium, if any point be taken, and the moments of the different forces of the system about that point ascertained, then the sum of the moments of those forces which tend to turn it one way, shall equal the sum of those which tend to turn it the other way." In each of the above cases, let the fulcrum be fixed upon, as the point from which the moments are measured. In each case, drop the perpendiculars  $CM$  and  $CN$ , from the fulcrum  $C^*$ , upon the directions of the force and resistance,

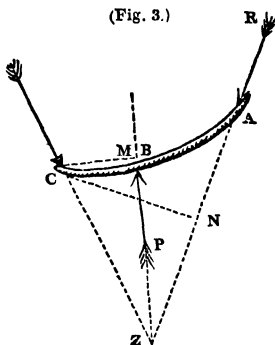

\* The lever is held at rest by *three* forces; but, if we select the point of application of one of them for the point about which we measure the moments, we shall get rid of the moment of that force; since the perpendicular upon its direction will be nothing, and therefore its product by that

respectively. Then by the principle of the equality of moments it will follow that in all the three cases  $P \times CM = R \times CN$ .

Hence it is apparent that if  $CN$  be less than  $CM$ ,  $R$  is greater than  $P$ , or the resistance greater than the power, and this inequality may be carried to any extent by diminishing the perpendicular  $CN$ . Thus we may increase the resistance which a given power will produce to any extent, by diminishing that arm of the lever to which it is applied, or causing its direction more nearly to approach the fulcrum. In levers belonging to the first and second classes, the resistance commonly exceeds the power; in the third class it is less than it. There is a popular error arising out of this fact, which it is worth while to notice. It is believed that, by the intervention of the lever, the greater resistance is made to be sustained by the lesser power. This is not the case. A greater force can, under no circumstances, be supported by a less. The fact is, that by the contrivance of the lever, a portion of the resistance is made to be borne by the fulcrum, the whole of it being divided between that point and the point of application of the power. And the same remark applies to all the various cases in which, by the aid of a machine, a less force is made to hold a greater in equilibrium.

96. Since the lever is, in each case, held at rest by three forces, *viz.*, the power, the resistance, and the reaction of the fulcrum, it follows, that the directions of these three forces must meet in a point. (Art. 22.) In all three cases produce the directions of  $P$  and  $R$ , to meet in  $Z$ . Then the direction of the third force, that is, the reaction of the fulcrum, is through that point. Also in each of the cases it acts through  $C$ . Join, therefore,  $ZC$ , and this line will be in the direction of the reaction. To determine its amount; from either of the extremities  $A$  or  $B$ , drop perpendiculars, one upon the direction of the force at the opposite extremity, and the other upon  $ZC$ . Then, as before, by the principle of the equality of moments, the product of the first perpendicular, by the force; shall equal that of the other, by the reaction of the fulcrum; thus, if the perpendiculars  $BK$  and  $BL$  be drawn from  $B$  (fig. 1),

$$P \times BK = (\text{reaction at } c) \times BL.$$

From the two conditions stated above, we can readily solve

perpendicular, nothing. Thus, selecting the point  $c$ , the principle of the equality of moments gives us a relation between  $P$  and  $R$ , *independent* of the reaction of the fulcrum. If we had taken any other point, this relation would have been *dependant* upon that reaction, which we are supposed not to know.

the following problems. First: Knowing the quantity and direction of the force applied to one extremity of a lever, to determine that which must be applied in a given direction to the opposite extremity, so as just to sustain it. Second: Knowing the forces applied to the arms of a lever, to find the pressure upon its fulcrum.

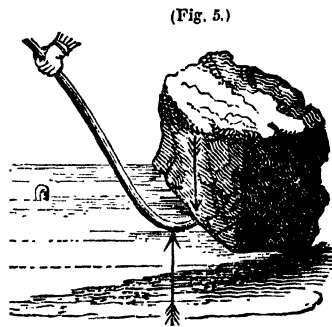
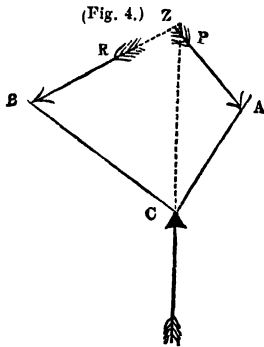

97. The conditions we have established obtain, whatever be the form of the lever; the proportion of the equality of moments being true, for systems of every form. Its shape may be angular as in the lever used for altering the direction of a bell-wire, fig. 4. Curved as in the crow-bar, fig. 5, and the pump-handle, or it may combine these forms as in the common hammer. In the crow-bar, fig. 5, the power is applied by the hand; the fulcrum is some hard substance against which the bent portion of the lever rests, and the resistance is the weight to be raised. The crooked

lever is applied with success to the sawing of wood by machinery. A lever  $PBA C$ , is fixed by means of a joint to the rod  $CD$ , and this again is jointed

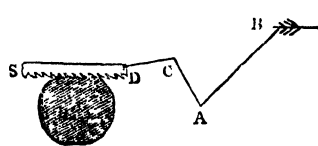

to the saw in  $D$ ; and the power is applied at  $P$ , in the direction  $BP$ . The fulcrum is placed at  $A$ , and as  $C$  is made to describe a circle, on or about this point, the saw is moved alternately, backwards and forwards. A pair of pincers, when used in drawing a nail, combines a double action of the lever. The two arms being acted upon at their extremities by forces, each represented by  $P$ , grasp the nail at  $R$ , with a force as much

greater as  $AR$  is less than  $AM$  or such that  $P \times AM = R \times RA$ . Again, the pincer acting to draw

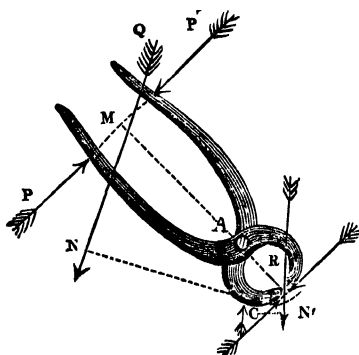

the nail upon the principle of a lever, whose fulcrum is  $c$ ; if we draw upon the direction of the resistance of the nail, and upon the direction in which the pressure of the hand tends to force it downwards, perpendiculars  $CN$  and  $CN'$ ; the latter force will be less than the former, in the proportion in which  $CN'$  is less than  $CN$ . Scissors, shears, and nippers, a common poker, a scale-beam, and a steelyard, &c., are

all levers of the first class, having the power and the resistance on opposite sides of the fulcrum.

The following belong to the second class of levers, having the power and resistance both upon the same side of the fulcrum, but the former being at the greater distance from it. The wheel-barrow—in which the axis of the wheel is the fulcrum; the weight of the barrow and load, the resistance; and the force of the labourer, the power. The oar of a boat—where the obstacle of the water to the motion of the blade of the oar, forms the fulcrum; the resistance is supplied by the rower of the boat; and the power, by the hands of the rower. Thus, the force with which the boat is impelled, is to that exerted by the rower, as the distance from the middle of the blade to the point where he grasps the oar, is to the distance from the same point, to the side of the boat. Common nut-crackers are examples of levers of the same kind, the fulcrum being in the hinge, the resistance in the shell of the nut, and the power in the fingers. To the third class of levers, in which the power is applied between the fulcrum and the resistance, belong the limbs of animals. Their fulcra are in the joints, the power is supplied by muscles, which apply it by the intervention of tendons, whose attachments are exceedingly near the fulcra, and the direction of their tensions very oblique to the direction of the limb. An arrangement which is necessary to preserve its compactness and symmetry. Hence, it is apparent, that the perpendicular from the joint, upon the direction of the tendon,

is necessarily exceedingly small, and, therefore, that the power of the muscle to sustain even the *weight* of the limb, must be enormously great.

The muscular powers of animals are probably among the greatest forces that exist. The great albatross has at his command a power, which, acting in a direction whose perpendicular distance from the joint of his wings cannot exceed half an inch, enables him to extend them through fourteen feet, and thus extended, to strike them fiercely against the air. To this class belong all those levers in which a small motion of the power produces a greater in the resistance, and in all of these, the power is less than the resistance. The treddle of a turning-lathe, a pair of tongs, or a pair of shears, such as are used in the shearing of sheep, are instances.

98. If the power and resistance act both perpendicular to

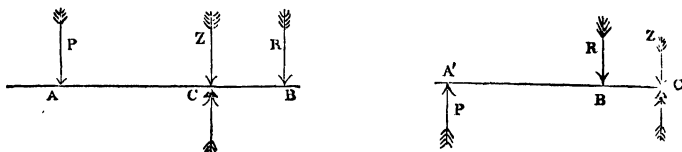

the arm of the lever; the perpendiculars upon their directions from the fulcrum, are their distances from that point measured along the arm: and the conditions of equilibrium resolve themselves into the following. That the force and the resistance, being each multiplied by the distance of its point of application from the fulcrum, the products shall be equal, or

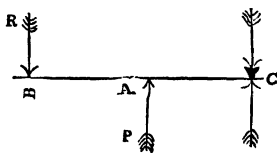

$$P \times CA = R \times CB.$$

The pressure upon the fulcrum is manifestly equal to the sum of the power and resistance, when these act upon the opposite sides of it, as in levers of the first class: when they act upon the same side, as in levers of the second and third classes, it is equal to their difference.

99. We have hitherto considered the only forces acting upon the lever, to be three; namely, the power, the resistance, and the reaction of the fulcrum. Every lever is, however, in fact, acted upon by an infinite number of other forces, in the weight of its parts. It has been shown, that these influence the equilibrium of the system, precisely as they would, if they were



collected in its centre of gravity. Let then the weight  $w$  of the lever  $AB$  be supposed to be collected in its centre of gravity  $G$ . The lever, in addition to the forces  $P$  and  $R$  at  $A$  and  $B$ , will now be acted upon by a third force  $w$ , in a vertical direction at  $G$ . Let  $CK$  be a perpendicular upon the vertical through  $G$ . Then it is necessary to the equilibrium, that the moments of  $P$  and  $w$ , should together equal that of  $R$  (Art. 35), or

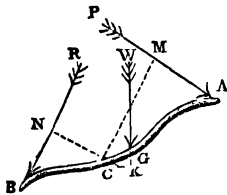

$$P \times CM + w \times CK = R \times CN.$$

It is clear, that the weight of the lever increases or diminishes the resistance, according as the centre of gravity lies on the opposite side of the fulcrum to it, or on the same side. It is also clear, that if the lever be so constructed as to bring its centre of gravity immediately over the point of support, or cause it to balance freely on that point, its weight will have no influence whatever upon the equilibrium, and may be supposed not to exist.

#### THE ROMAN STATERA.

100. *This* was the case in the Roman statera, or steelyard. A scale-pan having been suspended from the shorter arm, that arm was rendered so heavy, as to cause the whole system to balance upon its fulcrum  $F$ . The effect of the weight of the balance was thus

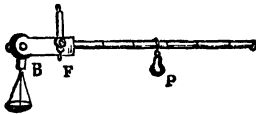

neutralized. The longer arm was then divided into parts each equal to the length of the shorter arm, and then again equally subdivided. And a weight  $P$ , was suspended to a ring, movcable along it. According as this weight was placed upon the first, second, third, &c., divisions of the arm, its moment would manifestly equal that of the same weight in the scale-pan, or be double of it, treble of it, &c. And, therefore, it would just balance an equal weight, or twice, or treble the weight, &c., in the scale-pan. Suppose the subdivision to be into tenths. Now each of these subdivisions over which  $P$  is moved further from  $F$ , being equal to one-tenth of  $FB$ , will increase its moment by one-tenth of  $P + FB$ . To preserve the equilibrium, the moment of the weight in the scale-pan, must be increased by the same quantity; but the distance  $FB$  remains the same, therefore, the weight itself must be increased by one-tenth  $P$ ;

in which case, the moment will be increased by one-tenth  $P \times FB$ , as was required. Hence it is apparent that if  $P$  be made to move over any fractional part of one of the greater divisions, the weight in the scale-pan must be increased by the same fractional part of  $F$ , in order that the equilibrium may be preserved. And hence, that to whatever fractional parts of the greater divisions the subdivision is carried, to the same fractional part of the weight  $P$ , may any article placed in the scale-pan be weighed.

#### THE STEELYARD.

101. THE steelyard now in use, is somewhat different from this. There are two fulcra, from either of which it may be suspended, and two scales of division corresponding to these, and marked on opposite edges of the longer arm. The instrument is seldom made so as to balance itself on either of its fulcra; the error which would result from the unequal action of its weight, being corrected, by commencing the divisions from that point, where the weight  $P$  would just balance the instrument, by itself. The division is then made as before, into parts equal to the distance of the fulcrum from the point where the object to be weighed is to be suspended; and these parts are equally subdivided. It is apparent, that since, when  $P$  is at the commencement of the division, the moments on either side of the fulcrum are equal; if it be moved onward through any fraction or multiple of the less arm, the same fraction or multiple of the weight itself must be suspended from the less arm to preserve this equality. Each division or subdivision of the greater arm, corresponds, therefore, to a weight equal to the same multiple or fraction of the moveable weight, which that division or subdivision is of the less arm.

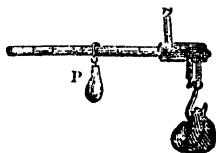

#### THE DANISH BALANCE.

102. THE Danish balance differs from the steelyard, in having a moveable fulcrum instead of a moveable weight. It surpasses all others in the simplicity of its construction, being, in fact, nothing more than a straight rod with a weight fixed at one end, a hook at the other, and a ring moveable along it, which serves as a fulcrum, from which the whole is suspended. The object to be weighed is suspended from the hook, and the fulcrum moved about,

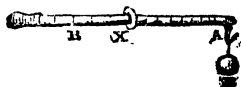

until there is an equilibrium. The weight is then read off on a division marked along the arm for that purpose\*.

THE COMMON BALANCE.

103. THE common balance consists of a rigid mass called the beam, in which are fixed transversely, at its extremities, and through its middle point, three axes,  $s, s',$  and  $F$ ; that,  $F$ , in the centre, serving to support the beam, and the two others,  $s$  and  $s'$ , carrying the scale-pans. The beam is commonly symmetrical, as to two lines, one traversing it longitudinally, and the other transversely.

The forces acting upon the beam are:—First, Its own weight.—Secondly, The weights of the scale-pans, and the weights they contain.—Thirdly, The reaction of the fulcrum.

The first may be supposed to be collected in the centre of

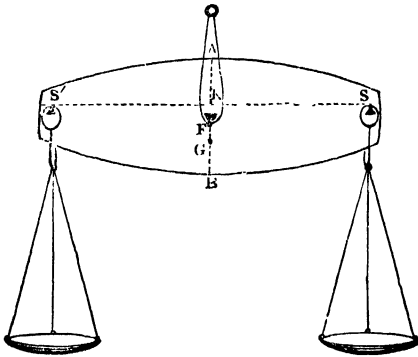

gravity  $G$ , which manifestly lies in that line of symmetry  $AB$  which cuts the beam transversely. — The second, act upon the beam in the points  $s$  and  $s'$ , and when they are equal may be supposed to be collected in  $K$ , the point of intersection of the line  $ss'$ , which joins them, with the vertical line of sym-

metry. When they are unequal, their resultant lies nearer to the point of suspension of the greater weight.

The resistance of the fulcrum is in the point of its contact, with the surface which supports the balance. Let  $K, F,$  and  $G,$  be the points in which it has been shown that the forces acting upon the beam may be supposed to be collected. The resultant

\* If  $B$  and  $F$  represent respectively the weight of the balance and the weight suspended from it, then, when the point of support  $x$  is in the position of equilibrium, we shall have, by the condition of the equality of moments,  $F \times AX = B \times BX$ ; or,  $F \times AX = B \times AB - AX$ ; and,  $\therefore F + B \times AX = B \times AB$ ; and,  $AX = \frac{B \times AB}{F + B}$ ; whence it appears that for equal increments of  $F$  the distances of the divisions on the arm from  $A$  must increase in harmonical progression.



unequal weights in the scale-pans, and although it poise itself accurately when no weights are placed in the scale-pans, yet is it a false balance. We may, however, weigh as accurately with it as with any other, if, after having placed such weights in either of the scales as shall accurately balance the article to be weighed in the other, we then remove the latter and observe what weights, placed in the pan from which it is removed, will restore the equilibrium. These precisely equal its weight. And this method is, perhaps, the most accurate that can be employed to ascertain the exact weight of any portion of matter.

104. There are few things in practical mechanics more difficult than the construction of an accurate balance; especially

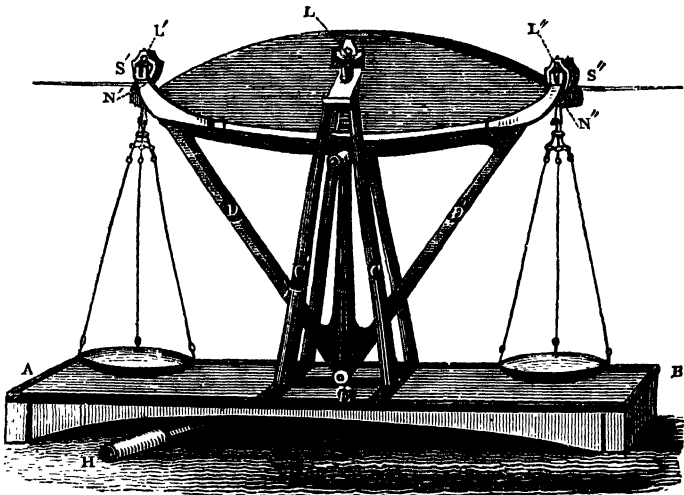

if it be required for ascertaining the weights of heavy masses. The combination of strength in its parts, and delicacy in its adjustment, is only to be brought about by great skill and perseverance, on the part of the artist.

The accompanying wood-cut represents a balance made by Mr. Bate for determining the weight of the standard bushel, combining these qualities in a remarkable degree.—Lightness being essential to the sensibility of the balance, the beam of this is made of dry wood; and that form is given to it, which supplies the greatest strength with the least quantity of material.—The beam is pierced through, near its centre of gravity, and through the aperture thus made, there is placed, transversely,

a solid mass of brass *L*, in which is fixed a wedge-shaped piece of polished steel, called a knife-edge\*, the section of which is represented at *F* in the smaller figure, and which extends completely across the beam. This knife-edge is adjusted so as to be accurately at right angles to the surface of the beam, by means of screws which are represented in the figure, and so as to be slightly above the centre of gravity of its mass by means of other screws, which are not shown.

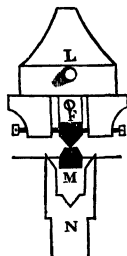

Passing through the same aperture, but wholly detached from the beam, and resting upon columns *c c'* on either side of it, is another mass of brass, on which is fixed a plane of steel *M*, traversing the beam, and sustaining the knife-edge, throughout its whole length.—When the balance is in action this plane sustains the whole of its weight, and that of the masses weighed in it, and the knife-edge is the fulcrum upon which the whole turns.

In the cross-piece which is supported by the columns *c c'* and which carries the steel plane *M*, is an aperture through which passes a fork-shaped piece of brass *N*, forming part of the frame-work *DEB'*, which is wholly detached from the beam when the balance is acting, but admits of being raised by the motion of the handle *H*, so as to cause the fork *N* to catch a projecting piece *L* in the mass which carries the knife-edge and is fixed in the beam. By continuing the motion of the handle, the beam, and with it the knife-edge, may be lifted from the plane on which it rests, and thus the injury which could not fail to arise from a *continual* pressure of the plane upon it, is prevented.

On pieces projecting from the extremities of the beam, and precisely at equal distances from its fulcrum, two other knife-edges *F'* are fixed across its upper edge, and like the former, at right angles to the plane of its surface. These are adjusted like the former, but they have their edges turned *upwards*. The scale-pans are attached, each, by a hook, to a piece represented at *s'*, and composed of two parts, each somewhat in

\* It was at first imagined that sharpness in the edge of the fulcrum was essential to the sensibility of the balance, and for this reason the edges of knives were not unfrequently used as fulcra. It has since been ascertained that a very considerable angle may be given to the edge of the fulcrum, without at all impeding the rotation; whilst the chance of injury to it, is thereby greatly diminished.

the form of a stirrup, receiving the projection of the extremity of the beam between them, and connected above by a steel plane

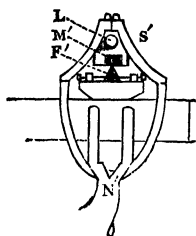

$m'$ , which rests on the knife-edge; and at bottom by a cross-piece on which the scale-pan is hooked. Thus is obtained that perfectly delicate suspension of the scale-pan upon the beam, than which nothing is more essential to the sensibility of the balance; for it is manifest that if with the inclination of the beam there be not a *simultaneous* revolution of both scale-pans about their points of support; the effect of that, carried by the ascending extremity,

will be the same as though it were suspended from some point more distant from its fulcrum than its actual point of suspension; whilst the effect of that carried by the descending extremity, will be the same as though it were suspended from some nearer point. Both these causes existing in ever so slight a degree, will have a tendency to impede the motion of the beam, and may seriously affect its sensibility.

The frame  $D E D'$  carries at its extremities two fork-shaped pieces of brass  $N'$ , similar to those at  $L$ , one on each side of the beam. These, when the frame is sunk to its lowest point, stand some inches clear of the extremities of the beam, allowing it to vibrate freely; but when the frame is raised by the motion of the handle  $H$ , they catch projecting pieces  $L'$  and  $L''$  in the stirrups, and lift the planes which these carry, from the knife-edges on which they rest. Thus the knife-edges are protected from injury when the balance is not in use, and the scale-pans may be loaded before their weight is thrown upon the beam; an arrangement affording great facilities in the use of the instrument\*. The adjustment of the knife-edges to their proper positions, is made by means of small screws by which they may be moved horizontally or vertically. That of the knife-edge in the middle to a point immediately above the centre of gravity of the beam, which is the most difficult, is facilitated by means of small weights which screw upon wires represented in the figures as projecting horizontally from the extremities of the beam. These

\* An improvement has recently been made by Mr. Bate in this part of the arrangement. By a very ingenious contrivance, the beam and scale-pans are first of all made to be suspended upon cylindrical axes, and then, by a further motion of the handle  $H$ , to rest upon the knife-edges. Thus an opportunity is afforded of bringing the weight in the scale-pans very nearly to an equality, before that extreme sensibility is given to the balance which renders the adjustment difficult.

being screwed nearer to, or further from, the fulcrum, give a corresponding but very slight motion to the centre of gravity of the beam, thus causing it to take up the required position in respect to its fulcrum. The balance used by Capt. Kater for determining the standard pound weight was on this construction. With a weight of 250lbs. in each scale, the addition of a single grain caused an immediate deflexion of  $\frac{1}{20}$ th of an inch; so that the balance was sensible to the addition of the  $\frac{1}{175000}$ th of the weight it contained, and would weigh accurately to that fraction. This was, perhaps, the most perfect balance ever made for weighing considerable weights. Mr. Robinson adjusts his small balances so that, with 1000 grains in each scale, the index varies perceptibly by the addition of the  $\frac{1}{1000}$ th of a grain. So that his balances are sensible to the millionth of the weight.

MR. ROBINSON'S BALANCE.

105. THE most important peculiarities of this balance consist in the circumstance, that plane surfaces and knife-edges alone are brought in contact, and in the contrivances by which they are detached from each other, and again restored to contact at the same point of bearing. Fig. 1, represents the balance. The axis is a continuous knife-edge, firmly attached to the beam. Beneath this axis passes an agate surface, which is fastened to the fixed upright, *a*.

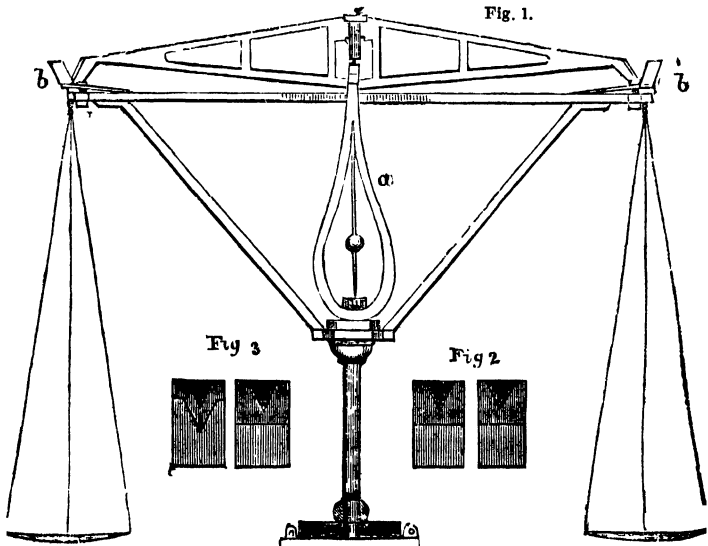



Fig. 4, represents one end of the beam, and the suspending piece for the pan. The knife-edge is fastened to the beam by the screw *a*, and is pressed by two screws, one of which is shown in the drawing. The object of these screws is to adjust the knife-edge parallel to the axis, which is done by relaxing one of these screws and tightening the other. The termination of the beam, to which the knife-edge is attached, is connected with the beam itself at the upper part. Through it passes a screw *b*, the point of which presses against the contiguous part of the beam. By screwing in the screw, the knife-edge would be removed farther from the axis, and also be raised, and the contrary by unscrewing it. By means, then, of these adjustments, the end knife-edges are placed parallel to, equidistant from, and in a right line with the central knife-edge. Each end of the end knife-edge, is terminated by a short cylinder. The suspending pieces of the pans have also similar cylinders, but longer, which, when the pans are suspended, are parallel to, and immediately over, the knife-edges. By means of these cylinders, and the frames *b, b*, fig. 1, at each end of the support, the beam is raised from the central surface, and the pans are raised from the knife edges.

Fig. 4.

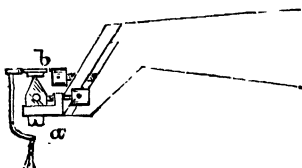

Fig. 5.



The sides of these frames are inclined outward, and their inner sides are formed as shown in figs. 2, 3. Fig. 2 has a Y on each side, to receive the cylinders of the suspending piece, and

Fig. 7.

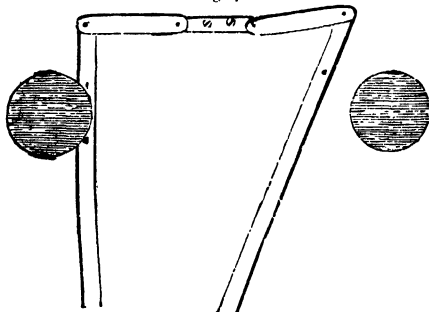
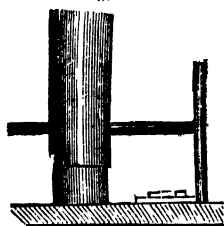

Fig. 6.



beneath are shoulders on which rest the cylinders of the knife-edge. Fig. 3 has similar Ys, and on one side a similar shoulder, but on the other side is a Y to receive one of the cylinders of the knife-edge. These frames are fastened to the support, which terminates in a tube fitting on a pillar. This tube is pressed upwards by an interior spring, and is drawn down to bring the balance into action, by a lever which passes through the tube and pillar as shown at figs. 5, 6.

On the index of the beam screws a ball, by which the centre of gravity of the beam is adjusted. Fig. 7, shows the arrangement for steadying the pans. Each arm is furnished with two upright pins; these are to be pressed against the pans previous to the support being drawn down, and are to be withdrawn after the edges and surfaces are brought in contact.

THE BENT-LEVER BALANCE.

106. THE instrument represented in the accompanying diagram is called the bent-lever balance. A bent lever,  $ABC$ , to whose extremity  $c$ , a weight is fixed, and to its extremity  $A$ , a hook, carrying a scale-pan, is moveable about an axis  $B$ . It is clear that the moment of the arm  $BC$ , varies with the perpendicular  $BD$  on the direction of the weight  $c$ , and, therefore, with the inclination of  $BC$ . Every different weight placed in the scale-pan will, therefore, produce an equilibrium in some new position of  $BC$ . The positions corresponding to different weights may be determined by experiment or calculation, and these being marked upon the quadrant  $FG$ ,  $c$  will always point to the weight in the scale-pan.

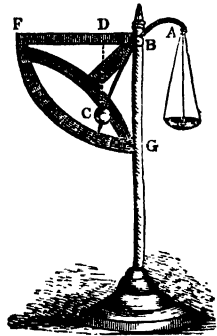

ON COMPOUND LEVERS.

107. LEVERS may be made to act upon *one another*, and the power of a system thus combined may be increased to any extent.

Let  $AP'$  and  $BP''$  be two levers, acting round fulcra  $F$  and  $F''$ ; and over their extremities let a third  $r'P''$  be laid, the resistance of whose fulcrum  $F'$  is in a direction opposite to that of the others. A power  $P$  applied at  $A$  will produce at  $P'$  a resistance as much

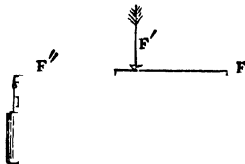

greater, as  $\Delta F$  is greater than  $P'F$ ; and this resistance acting as a power upon the lever  $P'F''$ , will produce a resistance at  $F''$ , or a power upon the lever  $F''R$ , as much greater than that at  $F'$ , as  $P'F$  is greater than  $F''F'$ , and thus, by continuing the levers, the resistance which a given power will produce, may be increased without limit.

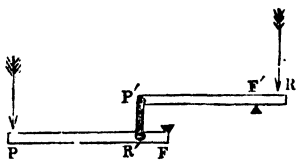

Two levers of the first and second classes are sometimes connected by a rod  $P'R'$ , jointed to both, as in the accompanying figure. The resistance  $r'$ , produced at  $F'$ , by the action of the force  $P$ , is such that

$$P \times PF = R' \times R'F.$$

And the resistance produced at  $R$ , by the action of  $R'$  at  $F'$ , is such that  $R' \times P'F' = R F' \times R$ .

Whence, multiplying these equations together, and striking out the factor  $R'$ , which occurs on both sides, we have

$$P \times PF \times P'F' = R \times R'F \times RF'.$$

Whence the power necessary to produce a given resistance may be known, or conversely. The levers used for raising carriages, to take off their wheels, are of this class.

### THE WEIGHING MACHINE.

108. A VERY ingenious combination of levers is used for determining the weights of carriages. An oblong platform of sufficient dimensions to receive upon its surface the carriage to be weighed, is supported at its angles upon a system of four levers whose fulcra are fixed in solid masonry, a short distance beyond the angular points, and which converge, in the directions of the diagonals of the oblong, towards a point in its centre. They there rest upon another lever, whose fulcrum is at a short distance from the point of convergence, and which passes under the road, and has its opposite extremity in the weighing-house.

Let us suppose the distance of the point, where each of the angles of the platform rests upon a converging lever, from the fulcrum of that lever, to be one-tenth of the length of the lever, and let the distance from the fulcrum of the great lever to the point where it supports the extremities of the smaller levers, be one-tenth of the distance from the fulcrum to the extremity of the lever in the weighing-house. Also let us suppose a weight of 4000 pounds to be placed upon the platform; this being divided equally between the points of support, each will bear

one-fourth of it, or 1000. Also a pressure of 1000 pounds applied at that point of each converging lever, where it sustains the platform, will be held in equilibrium by a pressure of 100 pounds applied at that extremity of it which is under the centre of the platform. The whole would, therefore, just be borne by 400 pounds at the centre of the platform; and this pressure again being thrown on one extremity of the great lever, will be borne by 40 pounds at the other extremity of that lever, in the weighing-house. Thus 4000 pounds may be weighed by means of a weight of 40 pounds.

## THE FULCRA OF LEVERS.

109. THE fulcrum of a lever is usually made in the form of a triangular prism, and sustains the pressure upon one of its angles, thereby opposing no appreciable resistance to the motion of the lever about its line of support. It either forms part of the lever, and rests upon horizontal planes fixed in an upright pillar on each side of it, or (as in the balance described, Article 104,) piercing it, or it is itself so fixed, sustaining the surface of the lever on a plane placed across it. We have hitherto supposed the fulcrum to supply a reaction, equal and opposite to the resultant of the forces upon the lever, in every position which it is made to assume. This is, however, only possible within certain limits. If the resultant make with the perpendicular to the surface on which the fulcrum acts, an angle, greater than the limiting angle of resistance, it will clearly slip upon that surface, and the equilibrium will be destroyed. This condition brings the possible cases of equilibrium under the circumstances described in the preceding propositions, within comparatively narrow limits.



110. If we would extend these limits, we must, by some mechanical contrivance, counteract the tendency of the lever to slip, under certain circumstances, upon its point of support. To effect this, the fulcrum may be converted from a triangular prism into a cylinder, and instead of resting on a plane, may be made to rest upon the interior surface of a cylindrical aperture in the mass which is to sustain its reaction. Thus formed, it becomes an axis of rotation. This axis, like the fulcrum, may either be fixed in the lever, and moveably inserted at each extremity in uprights projecting from a supporting column; or it may be fixed itself, in these supports, and moveably inserted in the lever. It will be apparent, hereafter, that the first arrangement possesses many advantages over the other. Whilst by this con-

trivance, we manifestly gain the advantage of a constant position of the point of support, whatever be the position of the lever, or whatever the forces which act upon it; we lose that perfect freedom of rotation which the other arrangement gave us. This will be readily understood. Where the surfaces of the lever and its support are in contact, in a single point, as in the case of the triangular fulcrum, it is manifestly necessary to the equilibrium, that the resultant of the forces acting upon it, should pass accurately through that point; otherwise the reaction of the support which takes place only there, could not sustain that resultant; and the lever having been thus placed in equilibrium, the slightest alteration made in the forces which act upon it, changing the direction of their resultant, would be sufficient to communicate motion to the whole. Whereas, in the other case, the lever and its support are in contact throughout the whole surface of the cylindrical aperture or socket, and if the resultant of the forces acting upon the lever pass through this surface, they will be sustained, whatever be the direction of that resultant, provided only that direction do not make with the perpendicular to the surface an angle greater than the limiting angle of resistance. Thus, if  $PE$  be the direction of the resultant, and we join  $CE$  ( $C$  being the centre of the axis, and  $CE$  being, therefore, perpendicular to its surface), this resultant will be sustained by the

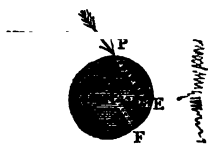

reaction of the support, whatever be its direction, provided only the angle  $PEC$  be less than the limiting angle of resistance. Hence, therefore, the forces acting upon the lever may be varied infinitely within certain limits, both as to quantity and

direction, without causing it to revolve. The greater the length of the lever, the greater is the distance through which a given variation of the forces acting upon it will move their resultant, the narrower, therefore, are the limits within which this variation is practicable—the dimensions of the axis being supposed to continue the same. It is manifest that by diminishing these dimensions, we can contract the possible limits, within which a variation of the force does not produce a corresponding motion of the lever, to any extent. That is, we may thus diminish, as far as we like, the effects of the friction of the axis.

#### THE CARRIAGE-WHEEL.

111. FROM the above considerations, we shall be enabled to explain the theory of the axis of the carriage-wheel. Let us suppose that, instead of being moveable round a small axis in its

centre, it were moveable round an axis having a diameter nearly equal to its own, so that the wheel constituted, in fact, a thin ring, just encompassing the axis. It is clear that the friction would then be the same as though the wheel were locked, and it were dragged along a road of the same material as the ring. Now we have pointed out the difference between the friction of an axis of these dimensions and a smaller axis, such as that of a carriage-wheel, the same difference is there, therefore, between the friction of a carriage drawn without wheels or with its wheels locked, and a carriage rolling freely on its wheels\*.

In overcoming obstacles, the action of a carriage-wheel is that of a lever of the first class. Let  $A$  represent the obstacle,  $CP$  the line of traction,  $CR$  a vertical through  $C$ . Then the forces acting upon the wheel are the reaction of the obstacle at  $A$ , the weight of the carriage sustained by the axle, and acting on the wheel in the direction  $CR$ , and the traction of the horses in the direction  $CP$ . From  $A$  let fall the perpendiculars  $AM$  and  $AN$  upon  $CP$  and  $CR$ ; then there is an equilibrium when the force of the horses is such, that its product when multiplied by  $AM$ , is equal to that of the weight multiplied by  $AN$ . A force slightly greater than this will be sufficient to draw the carriage over the obstacle.

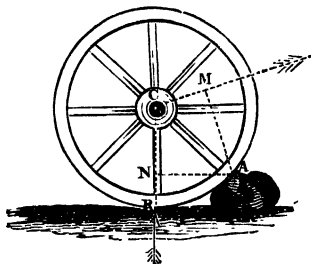

## CHAPTER IX.

- |  |  |
|--|--|
| 112 Irregularity in the action of a Force applied to the extremity of a Lever, whose direction passes always through the same point. | Axle, by which its power may be increased without limit. |
| Method of remedying it.  | 117 The Windlass.  |
| 113 The Wheel and Axle.  | 118 The Capstan.   |
| 115 Modification of the Wheel and  | 119 Tread Wheels.  |
|  | 121 Tread Wheels worked by horses.                       |
|  | 122 The Fusee.   |

112. THE *effect* of a force applied to the extremity of a lever being dependant upon the length of the perpendicular from the

\* If there were no friction upon the axle, the theory of the carriage-wheel would be the same with that of the rolling cylinder. (Art. 83.)

fulcrum upon the direction of that force, necessarily varies continually with the motion of the lever, provided the force be not in every position made to act at the same perpendicular distance from its fulcrum. Thus, a man who, standing in the same position, applies his strength, by means of a rope, to one extremity of a lever, and thus raises a weight attached to the other extremity\*, cannot produce the *same effect* in different positions of the arm of the lever by the *same expense* of muscular energy. He will find continually that his efforts must be *greater*, as the perpendicular from the fulcrum upon the direction of the cord which he pulls, is *less*.

A very simple contrivance will, however, enable him to give uniformity to the effect of his strength thus applied. Let  $PFQ$

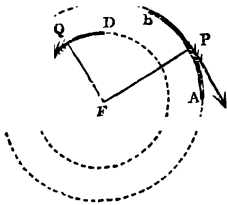

represent a lever, which may be of any form; and let there be fixed at its extremities,  $P$  and  $Q$ , two arcs of circles  $AB$  and  $CD$ , which have, both, their centres at the fulcrum or axis  $F$ . Let these form part of the mass of the lever, and let the cords to which the forces  $P$  and  $Q$  are to be applied, be attached to the upper extremities of these arcs.

As either extremity of the lever is pulled down, the cord will then unroll from this arc, so that its direction will always be that of a tangent to it, and the perpendicular upon that direction from the fulcrum will be a radius of the arc, and, therefore, always the same, whatever be the position of the lever. The perpendicular upon the direction of the force being thus always the same, the *effect* of the force will be the same.

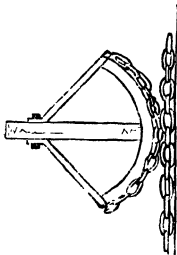

This principle has been used to convert the vibrating motion of the beam of a steam engine to the longitudinal motion requisite for working pumps, as represented in the accompanying diagram.

#### THE WHEEL AND AXLE.

113. IN communicating motion, the action of the lever is necessarily limited and intermittent. Thus, if a weight be attached by means of a cord to the extremity of a lever, we

\* As in the case of a drawbridge, or in the contrivance used for raising water in gardens near London.

can raise that weight by the action of the lever only to a given height, equal, at the utmost, to twice the length of the arm to which it is attached. The wheel and axle is a contrivance for extending the action of the lever to any distance, and rendering it continuous; these advantages being combined with the uniformity of effect spoken of in the last article.

Conceive the circular arcs  $AB$  and  $CD$  (see the first fig. in the preceding article) to be continued round, so as to form complete circles; and instead of the end of the cord being attached to the circumference in  $B$ , let it be any number of times coiled round it. The cord at the extremity of which  $q$  is made to act, being then of the requisite length, the action of  $P$  in giving motion to  $q$  may be continued through any distance. The value of  $P$  necessary to effect this must be greater than that which, being multiplied by  $FP$ , gives a product equal to the product of  $q$  multiplied by  $qP$ . It is manifestly immaterial, so far as these conditions of equilibrium are concerned, what are the widths of the edges of the two circles, round which the ropes are coiled. The smaller is commonly widened into a cylinder, called the axle. The other is made narrower, and is called the wheel.

114. The wheel and axle is principally used in the elevation of weights. It enables us, by means of a small force or weight, to raise a much larger. Since, in order that the power and weight may sustain one another, the power multiplied by the radius of the wheel must equal the weight multiplied by the radius of the axle, and that the radius of the wheel is greater than that of the axle; it is clear that the power must be less than the weight, or this equality could not exist. Thus, if the wheel be 18 inches in radius, the axle 3 inches, and the weight to be raised 36lbs.; since 3 inches, multiplied by 36lbs. (which product is 108) must equal 18 inches, multiplied by the power; it is clear that the power must equal 6lbs., since that number, multiplied by 18, will make 108. It is manifest, that theoretically we may increase the power of the wheel and axle to any extent, by increasing the radius of the wheel, and diminishing that of the axle. Practically, however, this is impossible. For if the radius of the wheel be greatly increased, it will be found difficult, and at

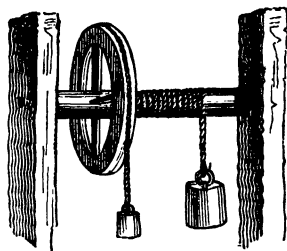



length impossible, to apply the power to it; and if the radius of the axle be greatly diminished, it will become so slender, as to be incapable of supporting the weight.

115. The following contrivance appears, however, to meet this difficulty, and enable us to increase the power of the wheel and axle without limit. Let us suppose three circles, turned upon the same block of wood, to have their common centre in  $c$ ; and let a rope attached to the circumference of the second circle in  $A$  pass round the pulley  $q$ , and be coiled in an opposite direction round the least of the three circles.

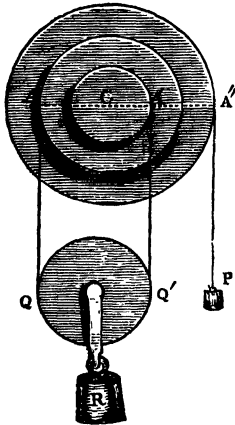

The weight is attached to the centre of the pulley  $q$ , and the power applied to a rope coiled round the largest circle. Now it is clear that the forces at  $A'$  and  $A''$ , acting on the same side the centre, both tend to support the force acting at  $A$ . Also, since the pressure of  $R$  is equally sustained by the two strings  $qA$  and  $q'A'$ , each bearing one-half of it; it is clear that the force acting at  $A'$  is equal to that at  $A$ , and would sustain it without the assistance of  $P$ , if the distance  $cA'$ , at which it acts, were equal to  $cA$ ; also that it will more nearly sustain it, as these distances are more nearly equal; so that we may make

the additional force to be supplied by  $P$ , as little as we like, by diminishing the difference of the radii  $cA$  and  $cA'$ \*. Thus the force  $P$  necessary to produce the equilibrium may be diminished, and the power of the machine increased to any conceivable extent.

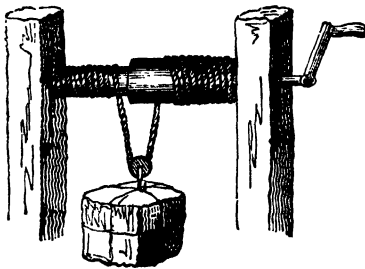

116. All the conditions of the equilibrium will manifestly be the same, if the circles be not in the same plane. The two interior circles are commonly cylinders on the same axis, and the force  $P$  is applied as in the windlass.

Sometimes the cords

\* Mr. Saxton has applied the principle explained above to the construction of a very ingenious pulley.

are coiled on different cylinders, and the same motion communicated to both by the intervention of a cog wheel. As more rope is coiled on the axle, the point from which it is suspended moves along it, and has a tendency to collect at its extremity, and encumber its revolution upon its axis. This tendency is sometimes counteracted by giving a curved form to the surface of the axle. This curvature rapidly increases towards the extremities of the axis; and as the coil approaches those points causes it to slip towards the centre.

## THE WINDLASS.

117. THE power, instead of being applied to the axle, by the intervention of the wheel, is sometimes applied by means of a lever fixed in its extremity, and terminating in a handle parallel to its axis. It is then called the windlass. If the power be applied by the hand of the labourer in a direction perpendicular to the arm of this lever, the conditions are the same as where the wheel is used.

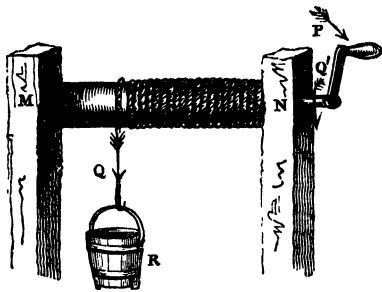

## THE CAPSTAN.

118. IF the cylinder, instead of having its axis horizontal, is placed vertically, it becomes a capstan. The power is applied to the capstan by means of a series of levers, placed at equal distances round it, in the direction of radii. To each of these the force of one or more individuals is applied at the same time.

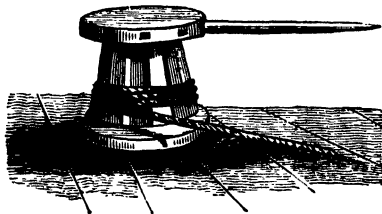

The capstan is principally used for raising the anchors of ships. A few turns of the cable are coiled upon the cylinder; these are sufficient to prevent it slipping; and as one extremity coils itself, the other rolls off, and is stowed away. It is evident that in this operation the

coil will have a tendency to move continually from one end of the cylinder to the other. To prevent this, a conical form is given to it, as represented in the figure; and towards the lower extremity its thickness increases very rapidly, and by this means the coil, when it approaches that extremity, is made continually to slip back again up the inclined plane of the sides of the cone.

#### TREAD WHEELS.

119. THE muscular strength of the legs being much greater than that of the arms, various methods have been contrived for

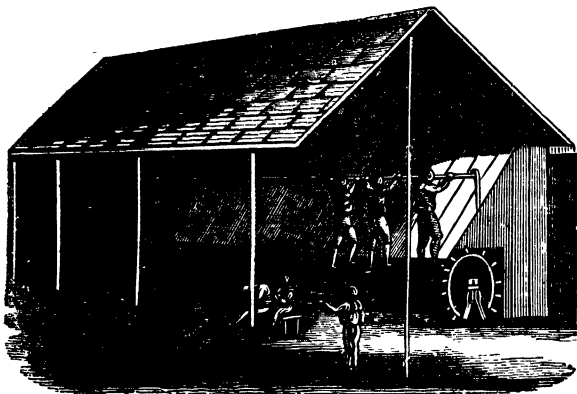

applying *tread* wheels to give motion to the axle. The accompanying diagrams represent two of these. In the last the weight of the body, and the muscular force developed by the individual in raising himself (the reaction of which is borne by the machine), *combine* to give the motion. In the first, which is that commonly used in our prisons, the reaction of this muscular force is principally borne by the bar which the prisoner grasps. The last contrivance appears to possess great advantages over the other in the economy of force, space, and materials.

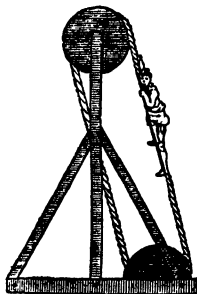

120. Numerous methods have been contrived, for combining the action of the weight and muscular force of horses, in giving motion to machines. The annexed figure represents one of these. The fore-feet of a horse rest upon a fixed platform,

and his hind-feet upon the circumference of a cylinder, which a portion of his weight, and the muscular energy of his hind legs, combine to put in motion.

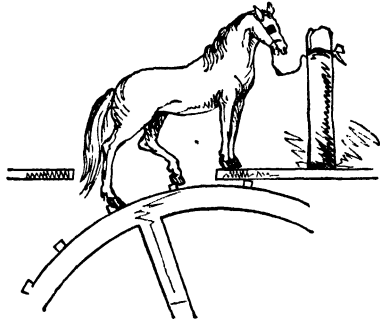

121. If the weight or force to be overcome be constantly the same, and it be required to overcome it by the action of a variable power; it is clear that this power must be applied at different distances from the axis. To effect this, the wheel, instead of being a cylinder, may be a cone of such a form that—imagining it to be cut at equal distances transversely—the radii of its different sections may increase or diminish exactly in the proportion in which the power to be used diminishes or increases; so that the small power, when thus placed, by the coiling of the string along the cone, at the greater distance, may produce the same effect as the greater power at the less distance.

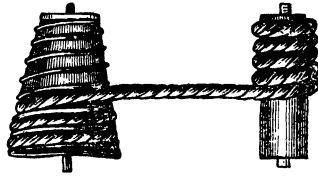

122. The conical wheel of a watch, called the fusee, is constructed upon this principle. The force of the spiral spring, which in uncoiling itself gives motion to the watch, is greatest immediately after it is wound up, and diminishes perpetually as the coil expands; the difference of force, corresponding to different degrees of expansion, being exceedingly great. Hence, therefore, if there were no check upon the variable action of the spring the watch would continually move slower, from the period when it was first wound up. And unless the dial-plate were unequally divided, we could not tell the time by it. The fusee obtains from this

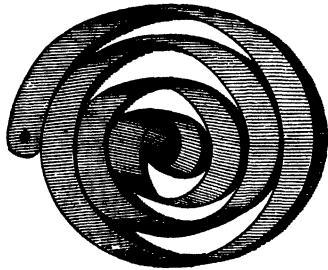

variable power a more equable one, which becomes the immediate moving power. The spring, in uncoiling, carries round with it the hollow cylinder in which it is enclosed, and which is called the barrel. To the outer surface of this cylinder a chain is attached, the remainder of which is coiled along a spiral groove cut on the surface of the fusee, and fastened at the larger extremity. When the watch is wound up, the chain occupies the whole of the groove on the fusee, and passes from its smaller extremity to the circumference of the barrel. The spring is then acting with its greatest force; but the chain, communicating its motion to the fusee, is acting upon its least extremity, and, therefore, with its least leverage, and with its least effect. As the spring further uncoils, and its force diminishes, the chain perpetually acts on portions of the surface of the fusee more distant from its axis, and, therefore, with a greater leverage, or effect. As the power of the spring, therefore, diminishes, its action on the watch is increased; and by a proper adjustment of the form of the fusee to its strength, it is manifest that this action may be thus rendered uniform.

The conical form of the fusee is sometimes given to the barrel of a windlass. The rope being fastened to the smaller extremity, the power acts at the greatest mechanical advantage when the whole is unwound, and the weight of the rope added to that of the mass to be raised. As, however, the weight of rope to be raised diminishes, it continually winds itself on a portion of the barrel of greater diameter.

## CHAPTER X.

- |   |   |
|---|---|
| 123 System of Cog Wheels, a Modification of the Compound Lever. | 125 Conditions of the Equilibrium of a System of Cog Wheels.  |
|   | 126 Friction got rid of by diminishing the size of the teeth. |

123. WE have explained the advantages arising from the combined action of two or more levers upon one another. The

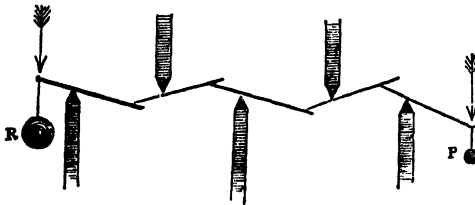

difficulty of communicating motion by means of a combination of levers, is, however, such as to render its practical application to any useful purpose scarcely possible. A very slight motion of either lever is sufficient to disengage its extremity from that of the next to it in the series, and the chain thus once broken, the system is destroyed, a catastrophe which it is scarcely possible to avoid, since little or no perceptible motion of the weight can be produced without a considerable motion among the first levers of the series.

124. Let us suppose two levers  $AB$  and  $ab$ , of which  $AB$  gives motion to  $ab$ , to be upon the point of disengaging their extremities from one another, after which their action upon one another would, of course, wholly cease. To continue the motion, let us suppose two other levers  $A'B'$  and  $a'b'$ , to be fixed at such angles to the first, that when they are upon the point of disengaging, these may just be coming into contact.

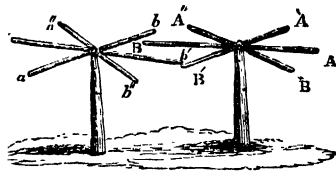

The action of the two systems upon one another will then be continued by this second pair of levers until they are disengaged; it may then be taken up by a third  $A''B''$  and  $a''b''$ , and afterwards by a fourth pair, and so continued throughout a complete revolution; and similarly through any number of revolutions, of both systems. And in the same way, instead of two, any number of similar systems may be combined, and their combined action continued through any number of revolutions. The portions of the levers which act upon one another lie near their extremities. All the remaining portion of each system may, therefore, form a continuous solid. It then becomes a cog wheel.

COG WHEELS.

125. Let us suppose two such wheels to be fixed on two axes, having the same centres  $c$  and  $c'$  with them. And round these axes let ropes be coiled in the same direction, carrying weights  $P$  and  $w$ . Let  $r$  and  $r'$  be two cogs at any instant in contact in the point  $q$ ; and let  $qmm'$  be the direction in which they press upon one another. From  $c$  and  $c'$  draw the perpendiculars  $cm$  and  $c'm'$  on this line.

Then, in order that the wheel, whose centre is  $c$ , may just

be held at rest; the moment of the pressure at  $q$ , must equal

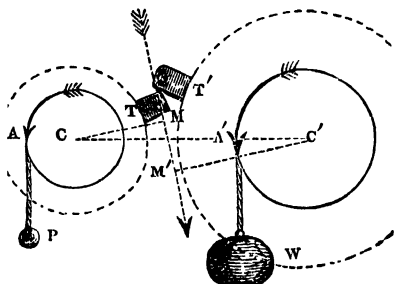

that of the weight  $P$ ; or being multiplied by  $cM$ , the pressure at  $q$  must equal  $P$  multiplied by  $cA$ . (Art. 36.) Hence it follows, that the pressure at  $q$  must equal the product of  $P$  and  $cA$ , divided by  $cM$ . And, similarly we shall find it to be

necessary to the equilibrium of the other wheel, that the force at  $q$  should equal the product of  $w$  and  $c'A'$ , divided by  $c'M'$ . So that the pressure at  $q$  equals both the quantities.

$\frac{cA \times P}{cM}$  and  $\frac{c'A' \times w}{c'M'}$  Wherefore these quantities equal one

another, or  $\frac{cA \times P}{cM} = \frac{c'A' \times w}{c'M'}$  and hence,  $P = \frac{c'A' \times cM}{cA \times c'M'} \times w$ .

Now it is evident that the cog  $T$  cannot give motion to  $T'$ , without at the same time slipping along its surface at  $q$ . And it cannot so move along its surface, unless the direction of  $MT$ , in which it presses upon it, be without the limiting angle of resistance (Art. 72), and, therefore, considerably inclined to the face of the tooth; but the more  $Mq$  is inclined towards  $qT'$ , the less is the perpendicular  $c'M'$ , and the greater is  $cM$ ; the greater, therefore, is the fraction

$\frac{c'A' \times cM}{cA \times c'M'}$ ; and the greater is the

power  $P$ , necessary to give motion to a given weight  $w$ .—Hence, therefore, there arises a great loss of power in the machine, from the sliding of the cogs on the surfaces of one another. This loss of power would be avoided if they could be so contrived as that in the motion of the machine they should roll, and not slide upon one another. With this view various curved forms have been given to them. Any geometrical discussion of the nature of these is beyond the scope of an elementary work. It may, however, be stated generally, that they are asserted to belong to that class, which are generated by the motion of a point in the circumference of one circle, rolling upon that of another, and

called epicycloidal or hypocycloidal, according as the moveable circle rolls on the outside or inside of the fixed one.

There is still another object, with a view to the attainment of which, it is most important to modify the forms of the teeth of wheels.—It is easily seen, by an inspection of the figure in the preceding page, that an uniform motion of the wheel *c* round its axis, does not by any means necessarily produce an uniform motion in the wheel *c'*. The angular velocity communicated to *c'* diminishes, in fact, from that position in which the edges of the teeth arc in the same right line until they finally leave one another. After all, however, it is scarcely possible to construct wheels such as will satisfy all these conditions; and were they so constructed, the unequal wear of the machine would soon alter their forms.

126. Friction is best got rid of, and uniformity of motion most completely produced, by making the teeth exceedingly small, and proportionately numerous. And when the strain is not considerable, this may be so far done as to render any irregularity in the motion almost imperceptible.

When the teeth are thus small, it is evident that any two which are in contact leave one another almost immediately after they pass out of the line which joins the centres of the wheels, and may be considered to touch only while they are in that line. Now whilst the surfaces of the teeth are in this line, the motion of the point of contact is perpendicular to both; they have, therefore, no tendency to slide upon one another, and there is no friction. Here, therefore, the pressure of one on the other is perpendicular to their common surface. And the perpendiculars *cm* and *c' m'* coincide with *cq* and *c'q'*. So that the conditions of the equilibrium become

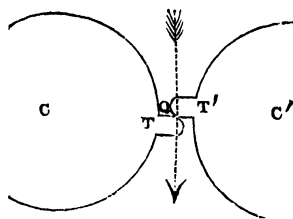

$$P = \frac{c' A' \cdot c q}{c A \cdot c' q'} \cdot W$$

Where *cq* and *c'q'* may be considered, since the teeth are very small, as equal to the radii of the wheels. Hence the following rule to find the power of a combination of two cog wheels. Multiply the distance at which the power is applied, from the centre of the first wheel, by the radius of the second wheel, and



multiply the distance at which weight acts from the centre of the second by the radius of the first. The quotient of these products will give the ratio of power to the weight, or the power of the machine.

127. And generally, if any number of cog wheels act upon one another, and we suppose the distances at which the power

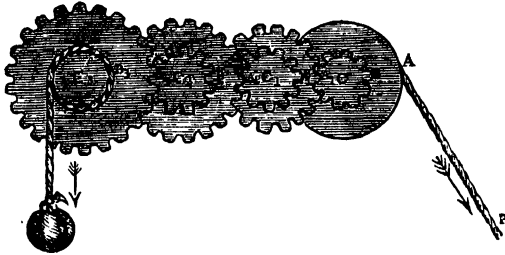

and weight act, from the centres of their respective wheels, to form the extreme terms of a series, of which the intermediate terms are the radii of the wheels in succession; then taking the product of the odd terms of this series, and dividing them by the product of the even ones, the quotient will represent the power of the system.—Thus, in the figure, the forces  $P$  and  $w$  act at distances,  $CA$  and  $C_3B_3$ , from the centres of the wheels to which they are respectively applied; writing these, therefore, as the extremities of a series, of which the intermediate terms are the radii of the other wheels taken in order, we have the series

$$CA, CB, C_1A_1, C_1B_1, C_2A_2, C_2B_2, C_3A_3, C_3B_3.$$

Hence, dividing the product of the odd terms of this series by the product of the even terms; we obtain, for the *power* of the machine the fraction

$$\frac{CA \times C_1A_1 \times C_2A_2 \times C_3A_3}{CB \times C_1B_1 \times C_2B_2 \times C_3B_3}.$$

## CHAPTER XI.

128 The Crank.  
130 The Eccentric.

131 The Stanhope Press Lever.  
132 The Camb.

### THE CRANK.

128. To the end,  $M$ , of a lever,  $CM$ , moveable about the centre  $C$ , conceive a rod,  $MN$ , to be attached by a joint, allowing

it to revolve freely about that point. This arrangement is that of the crank. The two forces applied to it, act one in the direction of the rod  $NM$ , and the other  $P$  (by means of a wheel or otherwise) on an axle, in which  $CM$  is fixed by its extremity  $c$ , and which axle,  $CM$  carries round

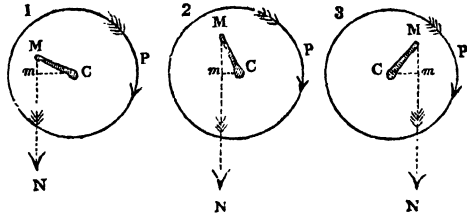

with it. The conditions of the equilibrium are, (Art. 36,) that the moment of the force  $P$  should equal the product of the force in  $NM$  multiplied by the perpendicular  $cm$ .

Now as the positions of  $CM$  and  $NM$  alter, so as to come more nearly into the same right line, the perpendicular  $cm$  continually diminishes; and when they attain that position, it vanishes. The force in  $MN$  must, therefore, continually increase, in order that the equality of moments may remain; and eventually no force, however great, will be sufficient to preserve this equality. For the moment of the force  $P$  applied to the axle, has a finite value; but no force multiplied by  $cm$  can have a finite value, when that line is evanescent. The equilibrium becomes, therefore, under these circumstances impossible; and



The equilibrium impossible; and

there is a certain position of the crank in which it will sustain the action of no force  $P$ , however small. When the muscular force of the arms is applied, in giving rotatory motion to a wheel, as in the accompanying figure, or as in the windlass, the action is precisely analogous to that of the crank.

129. By means of the crank, longitudinal may be converted into circular motion. Suppose the rod  $RM$  to admit of motion only in the direction of its length. At its extremity  $M$ , let a second rod  $MN$  be attached by means of a joint, and let this again be jointed to a third rod  $CN$ ; which carries, at right angles to its extremity, an axle moveable at  $c$  in a socket or bush. The rod  $cn$

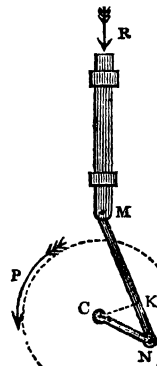

being made to revolve by means of the force  $P$  acting round this axle will carry the extremity  $N$  of the rod  $MN$  round with it, and thus communicate an alternate longitudinal motion to  $MK$ . Or, conversely, such a motion being by any means given to  $MK$ , the rod  $KN$  will be made to revolve about  $c$ , and the axle carried round with it.

#### THE ECCENTRIC.

130. Is another contrivance for converting continued circular into alternate rectilinear motion. A circle is fixed to the axis of the wheel or crank which carries the power, in a point  $c$  which is not its centre:  $LN$  is a frame in which is a circular aperture precisely of the size of the former circle, and which is placed upon it, or made to contain it. The extremity  $N$  of this frame may be jointed on a rod moveable only in a longitudinal direction, and intended to apply the force of the machine.

The tension upon the frame is manifestly in the direction of the line  $MN$ , passing through the centre  $M$  of the circle, about which line it is symmetrical. Taking, therefore,  $c$ , the centre

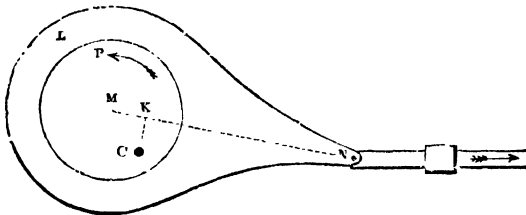

of the motion, and drawing the perpendicular  $CK$  upon  $MN$ , if the force  $P$ , applied to turn the circle about its axis  $c$ , remain the same, the strain, multiplied by  $CK$ , must remain the same. As, therefore,  $CK$  diminishes, the strain will increase, and conversely. The force  $R$ , necessary to the equilibrium, may be considered to vary nearly as the strain upon the frame.

The power of the eccentric is greater as the axis about which the circle is made to revolve, is less distant from its centre.

#### THE STANHOPE PRESS LEVER.

131. THERE are some facts with regard to the combination of two cranks, which are worthy of attention. Let us conceive two cranks, connected by the common rod  $MN$ , to have their centres of motion in  $c$  and  $c'$ . And let a given force act to give motion to the system by causing the revolution of  $cM$ . Now it has been shown that the strain produced by this force, in the

rod  $MN$ , will be greatest when  $CM$  and  $MN$  are nearly in the same right line. (Art. 127.) This strain is transferred to  $N$ , and tends to give motion to  $c'N$ . If, therefore, the system be so contrived that when  $CM$  and  $MN$  are nearly in a line,  $MN$  may be perpendicular to  $c'N$  so as to act upon that lever at the greatest advantage, it is evident that we may produce an enormous force tending to cause revolution in the axle to which that lever is attached. This arrangement of levers is that used in the Stanhope printing press. The axle  $c'$  there drives a screw, pressing the paper to be printed, with enormous force upon the type.

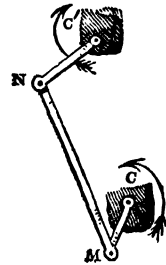

## THE CAMB.

132. THE camb is an instrument which under various forms, enters largely into the construction of machinery. Its office may be defined to be that of converting an uniform rotatory motion, into a varied rectilinear motion.  $CE$  is a rod admitting of motion in the direction of its length, and held in contact with the edge of the irregular mass  $AD$ , either by its own weight or by the pressure of a spring. This rod carries with it that portion of the machinery by which the irregular motion required is to be applied, and the irregularities upon the edge of the mass  $AD$  are such, as it is ascertained by trial, will communicate this motion, when the mass is made to revolve uniformly upon an axis  $B$ , round which it is moveable.

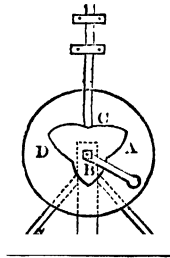

Some of the most ingenious of the combinations of this instrument are to be found in the machinery for making lace. The extreme variety and intricacy of the motions there derived from the regular motion of the piston of a steam-engine, or the continued revolution of a water-wheel, together with their extreme rapidity, precision, and accuracy, rank among the greatest wonders of the science of practical mechanics.

The relation between the power applied to give a rotatory motion to the camb, and that by which the slide is, in any of its positions, driven forwards, may be estimated as follows Through the point where the slide is in contact with the edge of the camb, draw a line inclined to the perpendicular to its surface, at an angle, equal to the limiting angle of resistance, and

from the axis of the camb let fall a perpendicular upon this line. The resistance between the camb and slide will be found (Art. 36) by dividing the moment of the force applied to turn the camb (*i. e.*, in the figure its product by the length of the handle,) by this perpendicular. But the whole resistance of the camb and slide on one another is not effective in giving motion to the latter; part of it being borne by the surfaces between which it moves, and which serve to guide it. To obtain the portion of the whole force *effective* in moving the slide, we must multiply the resistance by the cosine of the angle which the line of resistance makes with the direction of the slide.

From what has been said above, it is apparent that such a form may be given to the edge of the camb, that it shall be impossible to turn it, however *slight* the pressure of the slide may be upon it.

## CHAPTER XII.

The Theory of the Screw.  
 The Clamp.  
 The Winch.  
 The Micrometer Screw.

The Endless Screw.  
 The Conical Screw.  
 Hunter's Screw.

### THE SCREW.

133. THE screw presents a combination of the moveable inclined plane and the lever. It is clear that the equilibrium of the mass *M* (fig. page 67), depends upon the forces which act upon it, and the inclination of that portion of the inclined plane with which it is in contact; and has nothing whatever to do with the form or inclination of the other portions of the inclined plane. Now let us suppose the portion of the plane with which *M* is in contact to be exceeding small, and that portion of the plane remaining unaltered, let us suppose the rest of it to be

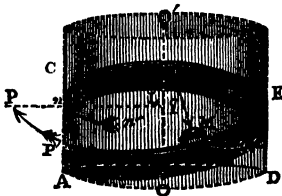

bent round a vertical cylinder, the line *AB* just reaching round its base, and the two extremities *A* and *B* being brought to meet. The plane will then assume the form represented in the accompanying figure. The points *A* and *B* coinciding in *A*; *AEC* being the surface, and *AC* the back of the plane.

Suppose the whole to be made moveable about a fixed axis *oo'*, coinciding with the axis of the cylinder. And let the

force  $n'n$  be applied to the back of the plane in a direction round this axis. This force will be propagated to  $q$ , and act upon that point parallel to the base of the plane, precisely as it did before the plane was curved; the equilibrium will, therefore, remain under the same circumstances.

We may suppose the force  $n'n$  to be generated by means of a lever, having its fulcrum at  $L$  in the axis of the cylinder, and acted upon by a force  $P$  in the direction  $P'P$  at its extremity. The requisite pressure at  $n$  would be generated by a much smaller force at  $P$ . It has been shown (Art. 86) that the effect of a force  $n'n$  applied to the back of a moveable inclined plane, upon an obstacle  $M$ , opposing itself to the motion of the plane, and acting on its surface, is always in the limiting direction of the resistance of the plane, that is, inclined to a perpendicular to its surface, at an angle, equal to the limiting angle of resistance. Knowing, therefore, the amount of the force  $n'n$  or  $q$ , which acts parallel to the base of the plane, and also the *direction* of the resistance  $q$ , we can find the amount of the latter. (Art. 80.) When the forces which hold the mass  $M$  in its place, (commonly its cohesion to the other parts of the mass of which it forms a part,) are not sufficient to produce this resistance, the mass  $M$  will yield, and move up the surface of the plane.

Let us now suppose a second inclined plane to be wound round the cylinder, beginning from the point  $c$ , and having its base parallel to the base of the cylinder. The equilibrium of a mass similarly pressed upon this, will be precisely similar to that upon the other. Suppose a series of such masses all pressed upon the plane by equal and similar forces, to occupy the whole length of the plane, and be in contact with every portion of it. The conditions of the equilibrium of each will be the same, and may be brought about by the action of a lever similar to  $PL$ ; or a single lever placed at the top or bottom of the cylinder, may be made to do the work of all these separate levers. Thus constructed the instrument will form a screw;  $AD$  is its base,  $AE$  is one of its threads, and  $AC$  the distance between its threads. The force impressed upon the lever will be upon the point of giving motion to the whole, when it is such as to cause the direction of the pressure upon the different points of the thread of the screw, to make angles with the perpendicular to it, equal to the limiting angle of resistance.

134. The screw which we have described is called a male screw. If, instead of being wound round the outside of a solid cylinder, the inclined plane had been wound round the inside of

a hollow one, its surface would have formed the thread of a female screw. If the diameters of the two cylinders and the dimensions of the planes be, in both cases, the same, these two screws will exactly fit; and their threads may be made to coincide. If either be then fixed, and the other be turned round upon its axis, it will be made, besides its rotatory motion, to move also in the direction of its axis.

135. The clamp and the winch, represented in the two first of the accompanying engravings, present instances of these applications of the screw. In the first the female screw is fixed and the male moveable: in the second, the female screw is moveable and the male fixed. If one be so fixed that it cannot move in the direction of its length, but may revolve round its axis, and the other admit only of motion in the direction of its length; then a rotatory motion being given to one, a longitudinal motion will be communicated to the other. Of motions of this class, the instrument represented in fig. 3 presents an instance; it is called the *Micrometer Screw*.

Fig. 1.



Fig. 2.



Fig. 3.



136. The substances to which great pressures are required to be applied, are, for the most part, in their nature, more or less yielding and compressible; under every variation to which their form is thus subjected,

it is, nevertheless, required to act on them with the same force and without intermission. Of all the mechanical powers, the screw is the best calculated to generate this kind of pressure. The action of the lever alters continually, as its position alters by reason of the yielding of the surface on which it is made to act, and the pressure is necessarily intermittent. The screw acts continually, with the same pressure, in the same direction, and never releases its hold.

137. The power in the screw is greater as the inclination of the plane which forms its thread, and the limiting angle of resistance on its surface are less, and as its radius is less, in comparison to the length of the lever at whose extremity the power is applied to it. Hence, therefore, if the friction be the same, and we use the same lever, the power of the screw will be greater as its diameter is less, and the distance between its threads less, or the thread finer.

138. As, however, we diminish the diameter, and increase the fineness of the thread, we diminish its strength; there would,

otherwise, be no limit to its powers. An arrangement of the screw has been contrived by Mr. Hunter, by which these difficulties are in a great measure obviated. It consists in the combination of two screws, one of which works within the other. The power of this compound screw does not depend upon the actual distances between the threads of the simple screws of which it is composed, but upon the difference of those distances. Hence, therefore, the threads themselves may be of any thickness and strength, provided only they do not greatly differ in thickness from one another.

Simple screws, however, are readily made of prodigious power. The first motion which the huge hulk of a ship receives when she is launched, is from the action of a small screw. A screw first sends the cradle, in which she rests, forward on the slips, and these being inclined, she then glides down by her own weight into the water. Under the action of the screw a huge bale of cotton, of which a few would fill up the hold of a vessel, shrinks into a small package, and from being the lightest and most buoyant of substances, becomes heavy enough to sink in water. Its uses are innumerable. It compels vegetable substances to yield up their juices. It is the great agent in packing, in coining, in printing, and in stamping. There is no timber so hard that a screw will not penetrate it, and when once fixed, there is no power acting in the direction of its length that can tear it out. It may thus be made to bind two pieces of wood together as firmly as though they were one. Great piles of building have been raised from an inclined to a vertical position, by means of a small screw, acted upon by a comparatively small force.

138. The screw is sometimes combined with the cog wheel, and it then constitutes what is called the *Endless Screw*. This combination may be produced by placing the axis of the screw in the plane of the wheel, as in the figure, or at right angles to that plane, as in the American endless screw. In either case the cogs must have a conformation suited to the inclination of the thread. The distance between any two threads of the screw must exactly equal the width of one of the teeth of the wheel; so that a *complete* revolution of the screw is necessary to move the circumference of the wheel, through a distance equal to one only of its cogs.

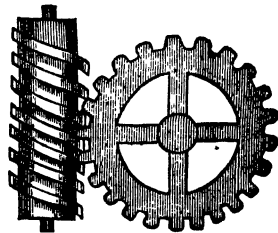



139. Sometimes the screw, instead of acting on cogs raised upon the edge of the wheel, is made to act upon the thread of a female screw sunk in its edge, as in the accompanying figure; an arrangement which presents the advantage of a more convenient form, and a steadier action of the screw on the circumference of the wheel. It has been shown that a cog wheel constitutes, in fact, a series of levers, and that the screw is no other than a winding inclined plane. The

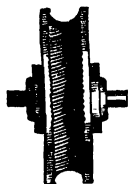

endless screw is, therefore, a combination of the inclined plane and lever.

140. Instead of being generated by the winding of a plane about a *cylinder*, the thread of a screw may be formed by winding an inclined plane about a *cone*. A screw thus formed, combines, with the pressure of a cylindrical screw, the action of a wedge, and its power to make its way into any solid substance is materially increased by reason of its terminating in a point. The gimlet and auger are instances of the application of this form of the screw. A screw of this form will readily be extracted.



## CHAPTER XIII.

- |                                 |                                      |
|---------------------------------|--------------------------------------|
| 141 On Flexibility.             | 150 The First System of Pulleys.     |
| 142 On Tension.                 | 151 The Second System of Pulleys.    |
| 143 On the Friction of a Cord.  | 152 Combinations of the Two Systems. |
| 144 On the Pulley.              | 156 Smeaton's Pulley.                |
| 145 The Single Fixed Pulley.    | 157 White's Pulley.                  |
| 147 The Single Moveable Pulley. |                                      |
| 148 The Spanish Barton          |                                      |

141. A FLEXIBLE body differs from a solid in this, *that it resists the action of a force tending to alter its form or separate its parts in certain directions only, whereas a solid exerts that power in every direction.* A cord is a flexible body, in the form of a slender cylinder. It is commonly formed of the fibres of certain vegetable substances twisted together. It is said to be perfectly flexible when it resists the action of such forces as are applied to it only in the direction of its length. This power of resistance is called its tension. The tension on

every part of a rope, acted upon by forces at its extremities, is the same. For, suppose the rope  $AA'$  to be at rest, the forces acting upon its extremities are then equal.

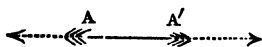

(Art. 5.) Now the tension at  $A'$ , being the resistance which the rope opposes to the action of the force at that point, is equal to that force; and, therefore, to the force at  $A$ . And this is true wherever in the rope,  $A'$  be taken; the tension, therefore, is everywhere equal to that at  $A$ .

A cord when stretched in a right line thus furnishes us with an easy method of transmitting force from one point to another. It is not, however, only, when stretched in the same *right line*, that a cord has the property of transmitting force from one point to another; it retains this property when *curved*. A line when *curved* may, in fact, be conceived to be made up of an infinite number of short *straight* lines, whose inclination to one another is so exceedingly small, that each may be considered to be in the same straight line with the two which adjoin it. This being the case, it is very clear that whatever is the tension on the first of these lines, will be transmitted to the second, and so on, all through the curve.

Hence, therefore, *the cord*, also supplies us with the means of transmitting force in a curved line, and producing it at *one extremity* of that line, whatever be its form or length, with the same energy with which it is impressed at the *other*. The difficulty, however, lies in curving it. It is clear that, by reason of its *flexibility*, it cannot retain any *curved* form which is given it, except by the action of *certain forces*. The most convenient method of supplying these, is to cause it to be stretched over some solid body, by the reaction of whose surface it may be made to retain the curvature required. If this *reaction* were exerted, everywhere, only in a direction *perpendicular* to the surface, it would not destroy that equality of the tension, of which we have spoken. In fact, acting everywhere *perpendicular* to the tension, it could not affect it. But, unfortunately, there is no surface, whose reaction is thus exerted. (Art. 73.)

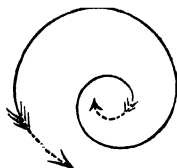

142. The resistance of a surface may always be resolved into two, one in the direction of the perpendicular and the other in the direction of the surface itself. *This last* resistance opposes, and diminishes, continually, the tension of the cord, with such rapidity, that there are few tensions sufficiently powerful not to be wholly destroyed by two or three coils.

This being the case, it becomes impossible to transmit force by the means we have stated, except at a great loss\*.

\* The following facts with regard to the friction of ropes are of sufficient importance to claim a place here, although the principles on which they are established cannot be explained.

If a cord be wound round any portion of a cylinder, the friction will be the same whatever be the radius of the cylinder, provided only the angle subtended at the centre by the arc, about which it is wound, is the same. Thus, if the cord be wound half round the cylinder, so as to subtend  $180^\circ$  at the centre, or entirely round, so as to subtend  $360^\circ$ , it matters not what the radius of the cylinder may be, the friction will always be the same. If we coil a rope half round a cylinder; once and a half round it; twice and a half round it, and so on, the corresponding frictions will be represented by a series of numbers, any one of which is equal to the preceding, multiplied by the square of the first term of the series.

In general the index of friction upon a rope wound half round a cylinder, may be considered equal to 3; the indices for one coil and a half, two coils and a half, &c., will therefore be,  $3 \times 9$  or 27;  $27 \times 9$  or 243;  $213 \times 9$  or 2187, &c.

So that if  $R$  represent the resistance acting at one end of the rope, and  $P$  be the power necessary to overcome it at the other. Then, coiling the rope as above, we shall have in the several cases: for  $\frac{1}{2}$  a coil  $P=3R$ ; for  $1\frac{1}{2}$  coils  $P=27R$ ; for  $2\frac{1}{2}$  coils  $P=243R$ ; for  $3\frac{1}{2}$  coils  $P=2187R$ , &c.

We may, from what has been stated above, readily explain the reason why a knot connecting the two extremities of a cord, effectually resists the action of any force tending to separate them. If a cord be wound round a cylinder as in fig. 1, and its extremities be acted upon by two forces  $P$  and  $R$ , from what has been said above, it appears that  $P$  will not overcome  $R$ , unless it equal somewhere about nine times that

force. Now if the string to which  $R$  is attached, be brought underneath the other string so as to be pressed by it, against the surface of the cylinder, as at  $m$ , fig. 2; then, provide the friction produced by this pressure, be not less than one-ninth of  $P$ , the string will not move even although the force  $R$  cease to act. And if both extremities of the string be thus made to pass between the coil and the cylinder, as in fig. 3, a still less pressure upon each will be requisite. Now by diminishing the radius of the cylinder, this

(Fig. 1.)



(Fig. 2.)



(Fig. 3.)



(Fig. 4.)

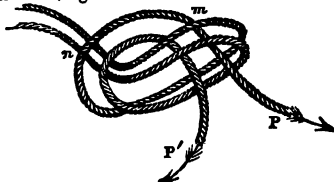

pressure can be increased to any extent, since, by a known property of funicular curves, it varies inversely as the radius. We may, therefore, so far diminish the radius of a cylinder, as that no force however great shall be able to pull away a rope coiled upon it, as represented in fig. 3, even although one extremity were loose, and acted upon by no force.

Let us suppose the rope to be doubled as in fig. 4, and coiled as before. Then it is apparent, from what has been said before, that the cylinder may

143. The pulley is a contrivance to obviate this difficulty, and serves to transmit the tension of a rope without sensibly diminishing it, when bent or curved in any direction we may require. It is a narrow cylinder, having a groove cut in its edge, and being made moveable about its centre, by means of an axis, which is supported in a frame represented in the accompanying figure, and called its sheaf or block. The axle is

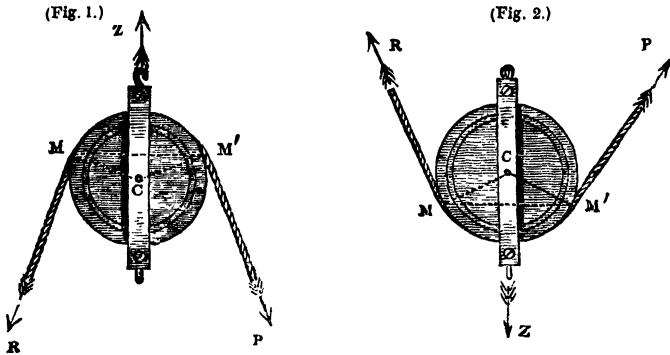

sometimes *fixed* by both its extremities in the block, and made to pass through a hole in the pulley, and sometimes, it is fixed in the pulley, and turns with it in holes which pierce the sides of the block.

#### THE FIXED PULLEY.

144. LET us suppose two forces  $P$  and  $R$ , to act in any directions at the extremities of a cord passing over a pulley having its sheaf *fixed*, and thence called a *Fixed Pulley*. The friction between the cord and the surface will, as we have explained, prevent its slipping over that surface. The forces  $P$  and  $R$  will therefore tend, each, to communicate motion to the pulley about its axis, and since they act at equal perpendicular distances,  $CM$  and  $CM'$ , from that axis, this tendency can only be so small, that no forces  $P$  and  $P'$  applied to the extremities of either of the double cords, will be sufficient to pull them from it, in whatever directions these are applied.

Now let the cylinder be removed. The rope then being drawn tight, instead of being coiled round the cylinder, will be coiled round portions of itself, at the points  $m$  and  $n$ , and the cord, instead of being pressed at those points upon the cylinder by a force acting on one portion of its circumference, will be pressed by a greater force acting all round it. All that has been proved before, with regard to the impossibility of pulling either of the cords away from the coil, will now obtain in a greater degree. In short, no forces  $P$  and  $P'$  acting to pull the cords  $P$  and  $P'$  asunder, can separate the knot.

be destroyed when they are equal to one another\*. We have thus, then, a means of transmitting a force without injury or diminution from one direction to another inclined at any angle to the first, and acting at any distance from it. From a force acting upwards, we can change it into one acting downwards, as in fig. 2, on the preceding page; and conversely, as in fig. 1. By combining two or more pulleys, there is no path, however long or tortuous, through which we may not thus transmit pressure unimpaired. When the forces acting upon a pulley are in parallel directions, it is evident that the pressure upon its axis is equal to their sum, (or, to twice the amount of either of them,) added to the weight of the pulley.

§ 146. When their directions are not parallel, the pressure upon the axis is equal to their resultant. This resultant may be determined as follows. Let  $m$  and  $m'$  (see figures, p. 113) be the points where the cord leaves the pulley. Join  $cm$  and  $cm'$ , these lines are perpendiculars to  $pm$  and  $rm'$ , the latter being tangents to the points  $m$  and  $m'$ . Join  $mm'$ , this line is also perpendicular to  $cz$ . Hence, therefore, it appears that the three lines  $cm$ ,  $cm'$ , and  $mm'$ , forming the triangle  $cm'm'$ , are perpendicular to the directions of the three forces which hold the pulley at rest, and are therefore proportional to those forces†, so that if one be taken to represent one of the forces, the other two will represent the other forces. Thus if  $cm$  be taken to represent the power  $P$ ,  $mm'$  will represent the resistance  $R$ , and this resistance may be determined by the proportion,

$$cm : mm' :: P : R.$$

\* No account is here taken of the friction of the pulley upon its axis, or against the sides of its sheaf.

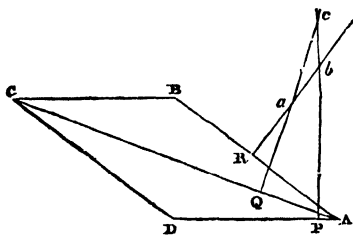

† This property may be proved as follows: Let  $AB$ ,  $AC$ ,  $AD$ , represent, in magnitude and direction, three forces holding a mass at rest; and forming, therefore, (Art. 16,) the sides and diagonal of a parallelogram.

From any points  $p$ ,  $q$ ,  $r$ , in the directions of these lines, draw perpendiculars,  $pc$ ,  $qa$ ,  $rb$ ; and continue them until each intersects the other two, and they form, together, the triangle,  $abc$ .

Employing the same power, but causing different portions of the string to be wound upon the pulley, it is clear that we shall increase or diminish the pressure upon the axis in the same proportion in which we increase or diminish the chord  $MM'$  of the arc in which it touches the pulley. And that the greatest value of the resistance is that for which  $P$  and  $R$  becoming parallel,  $MM'$  becomes a diameter of the circle (see fig. page 114), and equal to twice  $CM$ ; so that the greatest resistance is equal to twice the power.

147. In considering the conditions of the equilibrium of the fixed pulley we have neglected the weight of the cord. In practice, however, this weight constitutes an important element in the calculation. In the first place, the whole of this weight is clearly to be added to the pressure upon the axis. In the next place, if the length of string on either side this axis exceed that on the other, the weight of the excess must be added to *that* of the two forces on the side on which it acts. In almost all cases there exists this excess. Thus if a single fixed pulley be applied, as it frequently is, to raise the materials used in building to the top of a house, one end of the cord being held by a person at the level from which the weight is raised; it is clear that as it is drawn up, the excess of the weight of the string is on the side of the power, and tends to assist it; so that, when the weight approaches its greatest height, the effort necessary to raise it is considerably diminished. The weight of the string may, indeed, be such as to draw it up, after it has attained a certain height, with inconvenient rapidity. To prevent this, the end of a rope is sometimes attached to the weight, which uncoils itself as it ascends, and always balances the weight of the rope acting with the power.

Now it is a known principle of geometry, that if two lines be inclined to one another, at any angle; then any two lines drawn perpendicular to these, are inclined to one another at the *same angle*.

Hence, therefore,  $Pc$  and  $ac$  are inclined to one another at the same angle that  $AD$  and  $AC$  are; or, the angle  $Pca$  is equal to the angle  $DAC$ . For the same reason, the angle  $cab$  is equal to the angle  $cAB$ . Now the angle  $cAD$  is equal to the alternate angle  $ACB$ . (Euclid. Prop. 22, B. 1.) Therefore the two angles  $cAB$  and  $ACB$ , are equal to the two  $cab$  and  $acb$  respectively; and therefore, the triangles are equiangular and similar. (Euclid. Prop. 4. B. 6.) Wherefore, if we divide  $AC$  into any number of equal parts, and  $ac$  into as many; there will be as many parts, of the same length with the first, in  $AB$  and  $BC$  respectively, as there are of the same length with the second, in  $ab$  and  $bc$ . Now  $BC$  is equal to  $AD$ , being opposite sides of a parallelogram. Hence, therefore, it appears, that if any side  $ac$ , of the triangle  $acb$ , be taken to represent the force  $AC$ , to which it is drawn perpendicular, in *magnitude*; then, the other two sides  $ab$  and  $bc$  will represent, also in *magnitude*, the other two forces  $AB$  and  $AD$  to which they are respectively drawn perpendicular.

## THE SINGLE MOVEABLE PULLEY.

148. In the single *moveable pulley* (see fig. 1, page 113), instead of the power and resistance being applied to the extremities of the rope, one of these extremities is made fast to an immovable obstacle; the power  $P$  acts on the other, and the resistant  $R$  is the resultant of these, being applied to the sheaf. In the same way as before it may be shown that if the radius of the pulley be taken to represent the power, the chord  $MM'$  (see fig. page 113) of the arc of contact, will represent the resistance. Thus the greatest possible resistance, being that where the strings are parallel and the chord double the radius, is twice the power. Hence, by this pulley, a force of one hundred weight will raise a weight of two.

In practice the fixed and moveable pulley are commonly combined: the same cord passing over both, as in the accompanying figure (1).

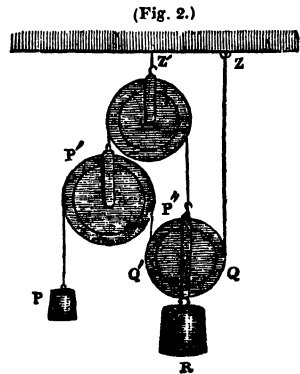
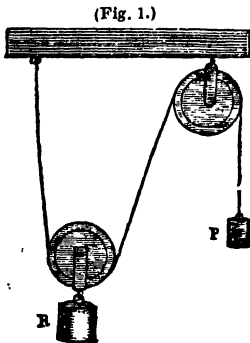

## THE SPANISH BARTON.

149. THE figure (2) represents a system of three pulleys, one of which is fixed and the other two moveable, called the Spanish Barton. The two moveable pulleys have their sheafs attached by the same cord  $P'Z'R''$ , passing over the fixed pulley  $Z'$ . The power  $P$  is made to act upon a second string passing over the first pulley, under the third, and fixed immovably in  $Z$ . The tension upon the cord  $PP'QQ'Z$  is everywhere the same (Art. 141), and equal to the power  $P$ ; whilst the tension upon the cord  $P'Z'$ , and, therefore upon  $P''Z'$ , is equal to twice the power. Hence, therefore, the third pulley is supported by three forces, the tensions of  $P'Q'$ ,  $ZQ$ , and  $Z'R''$ ; two of which

are equal to the power  $P$ , and the third to *twice* the power. On the whole, therefore, the force which sustains the resistance equals four times the power, or  $R = 4 P$ . The two moveable pulleys being here suspended at the extremities of the same string, manifestly balance one another.

150. Another system, consisting of two fixed and one moveable pulley, is represented in the accompanying diagram (1). The same string here passes round all three, carrying the power at one of its extremities; passing over the first fixed pulley  $A$ , round the moveable pulley  $P_1$ , and the fixed pulley  $P_2$ , then returning to be attached to the sheaf of the moveable pulley in  $P_3$ . The resistance  $R$  being here sustained by the *equal* tensions of the three strings,  $A P_1$ ,  $P_2 C$ , and  $P_2 P_3$ , equals three times the tension of any one of them: that is, it equals three times  $P$ , or  $R = 3 P$ .

(Fig. 1.)

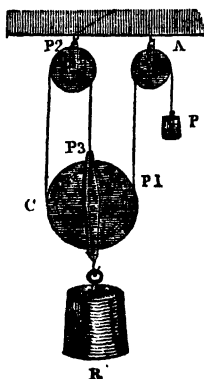

(Fig. 2.)

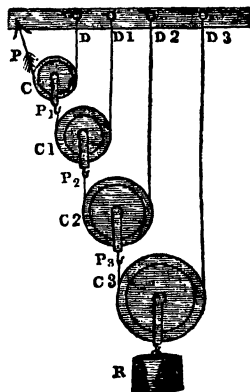

THE FIRST SYSTEM OF PULLEYS.

151. A number of moveable pulleys may be combined so as to increase the power of the system to any extent. Let the first pulley  $C$ , fig. 2, round which is passed a cord  $P C D$ , having one extremity acted upon by the power  $P$  and the other fastened to the immovable obstacle  $D$ , be attached, by its sheaf, to a second cord  $P_1 C_1$ , passing round a second moveable pulley, and attached to a second fixed point  $D_1$ ; also let a third pulley be, similarly connected with this, and so on. Suppose the fourth pulley to carry a weight  $R$ . Since the strings  $C, P_2$  and  $C, D_3$  sustain the weight  $R$  equally between them; therefore each bears half of it, and the tension upon the string  $P_3, C_3$  is half the



weight  $R$ . Now the strings  $c_1 d_1$  and  $c_2 p_2$  sustain this tension equally; each, therefore, bears one-half of it, or  $\frac{1}{2}$ th of  $R$ . And, similarly,  $p_1 c_1$  and  $c_1 d_1$  equally divide the tension upon  $p_2 c_2$ , each bearing  $\frac{1}{2}$ th of  $R$ , and  $c p$  and  $c d$  each one-half of this, or  $\frac{1}{4}$ th of  $R$ , which is, therefore, the amount of the force  $P$  necessary to the equilibrium, or  $R = 16 P$ . And so we might find the power necessary to sustain the weight, whatever was the number of the intermediate pulleys, by dividing the weight by the number resulting from the multiplication of 2 as many times by itself as there are such pulleys.

We have here neglected the weights of the pulleys themselves; the *additional* power, however, necessary to support each of these, is easily calculated by considering the weight of each as a separate force applied to *that pulley*. Thus, to support the first pulley, half its weight must be added to the power. To support the second  $\frac{1}{2}$ th its weight is requisite, for the third  $\frac{1}{4}$ th, and for the fourth  $\frac{1}{8}$ th. These being added to the power give the whole necessary to the equilibrium.

The pulleys are made, in the figure, to increase in diameter from the first. The reason of this is, that, the pressures upon the axes continually increasing, if we make the axis of the first, only of the requisite strength, that of the second must be of greater diameter that its strength may be sufficient; and that of the third of still greater, and so on. The axes thus increasing in diameter, the frictions upon them must also increase. The diameters of the pulleys should, therefore, increase, that each may act with the same power to overcome this friction.

#### THE SECOND SYSTEM OF PULLEYS.

152. In the system of pulleys we have just been describing, the resistance upon the cord of the last pulley, and the weights of the different pulleys, act against the power, or tend to increase it. We are about to describe a system, in which the tensions of the cords of all the pulleys act immediately on the resistance, and in which the weights of the pulleys *favour*, or act with the power.

$P_1, P_2, P_3$  are moveable pulleys, and  $P_4$  a fixed pulley. A string passing over the pulley  $P_4$  is attached by one of its extremities to a bar bearing the weight  $R$ , and by the other to the sheaf of a moveable pulley  $P_3$ , over which passes a second string acting similarly upon  $R$ , and carrying a third pulley  $P_2$ ; and the number may thus be increased to any extent. The string which passes over the last pulley sustains the action of the power  $P$ .

Now, the power  $P$ , by means of the cord  $p_1 p_1$ , sustains a portion of the weight  $R$  equal to  $P$ ; and further, it produces upon the cord  $p_2 p_2$ , by which the pulley  $P_1$  is suspended, a tension equal to  $2P$ , and, therefore, it thus sustains at  $p_2$  a further portion of the weight, equal to  $2P$ . This tension of  $2P$  upon  $P_2 p_2$  produces, again, upon  $P_3 p_3$  a tension equal to  $4P$  and sustains, therefore, at  $p_3$  a portion of the weight equal to  $4P$ . And similarly it may be shown that the portion of the weight sustained at  $p_4$  is equal to  $8P$ . Thus the weight  $P$  is made to sustain at the points  $p_1, p_2, p_3, p_4$ , portions of the weight  $R$  equal to  $P, 2P, 4P, 8P$ , respectively; and the whole weight sustained equals  $15P$ , or  $R = 15P$ . And in the same manner the relation of the power and weight may be calculated, whatever the number of pulleys of which the system is composed. We have here neglected the weights of the pulleys; it is evident that they all act to *support* the weight  $R$ . Their effect in doing so may be calculated precisely as before. The pulleys should increase in size from that which carries the power, for reasons assigned in the last article. Unless the weight  $R$  be suspended from that particular point in the bar though which the *resultant* of the tensions at  $p_1, p_2, p_3$ , &c., passes, the bar will be deflected from its horizontal position, and the system will become useless. This point is easily found by trial.

153. The two systems we have last described, are some-

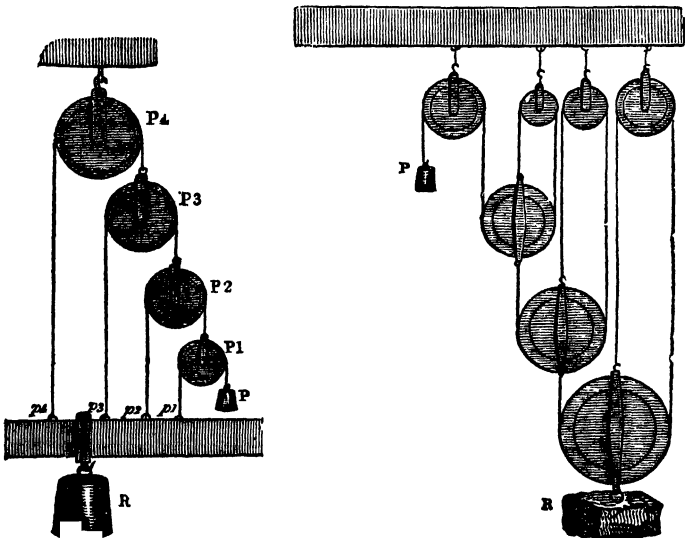

times modified by combining with each moveable pulley, a fixed pulley, of half its diameter. Its string is made to pass over this, and returns to be attached to its sheaf. Each moveable pulley then, instead of being sustained by the equal tensions of two strings, is sustained by the equal tensions of three; and the tensions upon the successive strings, instead of being, in order *double*; are *triple* of one another.

The relation of the power and resistance may, regard being had to this difference, be calculated precisely as before.

154. In practice the systems of pulleys we have been describing are of little or no use. Pulleys are commonly applied, not only to overcome great resistances, but to produce a greater or less degree of *continued motion*. Now turning back to fig. 1, page 119, it is apparent that by shortening any string which passes over a pulley by a certain quantity, we shall move the pulley itself and shorten the next string to which that pulley is attached only by half that quantity, and thus by giving a certain motion to the power, we shall cause the different pulleys, beginning from the first, to move over spaces each equal to half that moved over by the preceding pulley. Thus the pulleys will quickly be separated from one another. The one which carries the power will rapidly be brought down, and encumbered, and the tackle will become useless, almost before the resistance has been perceptibly overcome. For these reasons another class of pulleys has been invented, and is commonly used, not possessing, with the same number of pulleys, the same power, or the same freedom from friction; but admitting of a far easier application in practice.

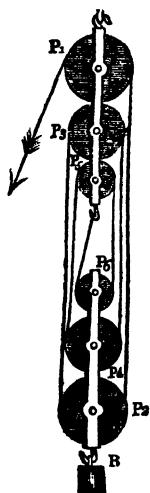

155. A and B are two blocks, in each of which are inserted a series of pulleys arranged beneath one another, and each moveable upon a separate axis. The upper block is fixed and the lower moveable, and connected with the weight R. A cord carrying the power, passes round the highest pulley in the upper block, and the lowest in the lower, and then round the two next of these in order, and so on continually; until at length its extremity is fixed in the extremity of the highest block. The tension of this cord is the same throughout; and, therefore, throughout, equal to the power. Now the effect of these tensions upon the lower block is, if they be parallel to one another,



considerably less than it has been determined in the preceding calculation.

WHITE'S PULLEY.

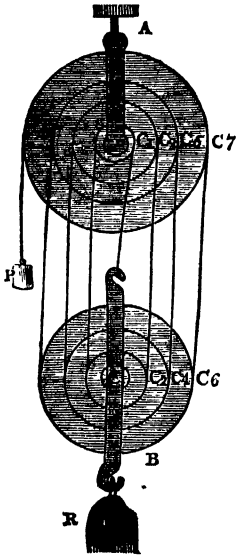

158. WHITE'S pulley is a contrivance for causing all the pulleys on each block to turn upon the *same* axis. A and B are blocks in which the pulleys, instead of being arranged beneath one another, or side by side, are placed upon one another, so as to have a common axis. The same string is passed, in succession, round all, beginning with the largest pulley of the higher block; and it is eventually fastened in the centre of the lowest block.

Let the two blocks be supposed to be made to approach one another through any space. Then none of the strings being supposed to become loose, the string \$c c\_1\$ will then be shortened by a length equal to that space, and this length of string will pass over the pulley \$c\_1\$, and also over the pulley \$c\_2\$;

but there will further pass over the pulley \$c\_2\$, the length of string by which \$c\_1 c\_2\$ is shortened, which is equal to that by which \$c c\_1\$ is shortened. On the whole, then, there will pass over \$c\_2\$ twice the length that passes over \$c\_1\$. Again, there will pass over \$c\_3\$ a length of string equal to that which passes over \$c\_2\$, together with the length by which \$c\_2 c\_3\$ is shortened. That is, there will pass over it three times the length which passes over \$c\_1\$; and so of the rest. The lengths of string which pass over the pulleys respectively will, therefore, be as the numbers 1, 2, 3, 4, 5, &c. Those which pass

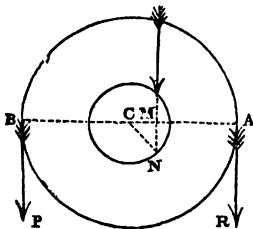

of the power and resistance passes through a point \$N\$, such that \$CNZ\$ equals the limiting angle of resistance. Hence, therefore, \$CN\$ being drawn inclined to the direction of \$BP\$ and \$AR\$, at an angle equal to the limiting angle of resistance; and \$NM\$ drawn through \$N\$ parallel to \$BP\$ or \$AR\$; \$R\$ is such that

$$P \times MB = R \times MA,$$

whence \$R\$ is known. The difference between \$R\$ and \$P\$ is the loss by friction.—(See Appendix.)

over the pulleys in the upper block, being as the odd numbers in the series, and those which pass over the others as the even numbers\*. It is manifest that certain dimensions must be given to the pulleys, that each in succession may thus take up all the string thrown off by that which preceded it in the series. It is easily shown that, to effect this, their radii must be in the upper block as the numbers 1, 3, 5, and in the lower as 2, 4, 6, &c.

There is considerable difficulty in making the pulleys precisely of these dimensions, especially as the radius of the string must, in each case, be added to that of the pulley. So great, indeed, is the difficulty, as to render any general use of this very ingenious pulley nearly impossible. The slightest deviation from the rule, such even as that produced by a trifling difference in the thickness of different parts of the string, is sufficient to render the tension on certain strings greatly less than that on others—some being looser and some tighter than others; and to destroy all the advantages which the arrangement offers.

#### CHAPTER XIV.

- |   |  |
|---|--|
| 159 The Conditions of a Rigid System necessary to the Equilibrium of a System of Variable Form, but not sufficient. | 170 The Upright Polygon of Rods.             |
| 163 The Suspended Polygon of Rods.  | 174 On Framing of Rods, or Netting of Cords. |
| 165 The Catenary.   | 177 On the Rigidity of Frames of Timber.     |
|   | 180 On Wooden Arches.                        |

#### ON THE EQUILIBRIUM OF A SYSTEM OF VARIABLE FORM.

159. THE conditions of the equilibrium of a *rigid system* are *necessary* to the equilibrium of a system of *variable form*, but they are *not sufficient*. For, let us imagine a system which admits of variation in the distribution of its parts, to be in equilibrium, by reason of certain forces which act upon it, and certain resistances among its parts. And let us then suppose those parts to be connected together, so that the whole may become solid, leaving the forces which act upon it, the same as before. Then, the additional power of resistance thus given to

\* Now whilst the two blocks are thus approached, all the pulleys on each (being fixed together,) revolve through the same angle. These different lengths of cord are, therefore, thrown off arcs subtending the same angles in the pulleys, and the lengths thrown off are equal to these arcs. Arcs subtending the same angle in the different pulleys of each block, are, therefore, to one another, in the upper block, as the numbers 1, 3, 5, and in the lower, as 2, 4, 6, &c. But the arcs subtending equal angles are as the radii. The radii of the different pulleys are, therefore, in the same proportion.

the parts of the system not taking away from the power of resistance which they before possessed, and which was sufficient to maintain an equilibrium among the forces applied to them, also those forces remaining the same, it is clear that the equilibrium which existed before will remain. But the system is now rigid. The forces which acted upon it and held it at rest, when its form was variable, are, therefore, such as would produce an equilibrium in it when rigid. They are, therefore, subject to the conditions of the equilibrium of a rigid system.

160. The *converse* of this proposition, however, manifestly *does not hold*. It *does not follow*, that if a certain number of forces be in equilibrium on a rigid system, they will remain in equilibrium when the form of the system is made to admit of variation. Thus the forces  $P$  and  $Q$  may be sufficient to hold in equilibrium the force  $R$ , so long as the rod  $PRQ$  is inflexible; but if we introduce a joint at  $R$ , the equilibrium will manifestly cease.



161. Again, if a solid mass\*  $AB$  be acted upon by two

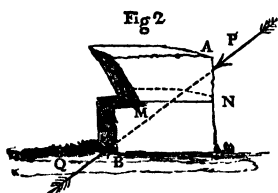
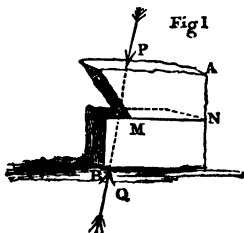

equal and opposite forces  $P$  and  $Q$ , it will remain at rest. But if it be intersected in the direction  $MN$  the equilibrium may be destroyed, either by reason of the upper portion turning upon its angle  $M$ , as in fig 1, the direction of the forces  $P$  and  $Q$  being *without* the common surface  $MN$ , by which the masses act upon one another (see Art. 55), or by reason of the upper portion sliding upon the surface of the lower, the direction of the line  $PQ$  being *without* the limiting angle of resistance, as in fig. 2.

162. The above are examples taken from two important classes of bodies of variable form; viz. 1. Systems formed of rods or cords, the parts of which are *connected together*, at their angles, but *moveable about* them. 2. Systems of solid bodies in contact, whose common surfaces are *not otherwise held together*, than by their mutual pressures. To the first class belong polygons of cords or rods, nettings, frame-work, and hanging curves, such

\* Supposed without weight.

as those used in suspension bridges. To the latter belong structures of all kinds. With regard to all these, the principle holds, that the forces which keep them at rest when their form admits of variation, would also keep them at rest if they were rigid.

ON THE EQUILIBRIUM OF THE POLYGON OF RODS OR CORDS.

163. LET  $P, P_1, P_2 \dots P_5$ , represent a polygon of rods or cords, supposed without weight, and acted upon at its angular points by the forces  $P_1, P_2, P_3$ , &c. Now the forces  $P, P_2, P_3$ , &c., would hold the system at rest, if it were rigid. Hence, therefore, if these

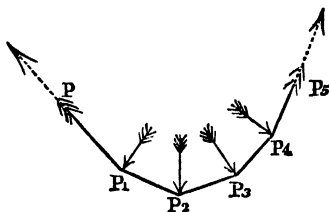

forces were removed to a single point, and applied to that point parallel to their present directions, they would be in equilibrium with one another. (Art. 37.) All the forces  $P, P_2, P_3$ , being applied, parallel to their present directions, to any angular point of the polygon, would, therefore, hold that point at rest. But further, it is clear, that if we suppose to be applied to any side of the polygon, in the direction of its length, a force equal to the tension on that side, and remove all that portion of the polygon which lies towards the direction of this tension, the remainder of the polygon will remain in equilibrium. Thus if we apply in the direction of the side  $P_2, P_3$ , a force equal to the tension on that side, we may remove the portion  $P_3, P_4, P_5$ , of the polygon, without disturbing the equilibrium of the remainder of it. Hence, therefore, the forces applied to  $P, P_1, P_2, P_3$  would hold it at rest if it were rigid. And if they were collected in  $P_2$ , they would hold that point at rest. Hence, therefore, the forces acting on any portion  $P, P_1, P_2$  of the polygon, are such as if applied to its extreme point  $P_2$  would be in equilibrium with the tension on the side  $P_2, P_3$ , terminating at that point.

164. This most important proposition, directs us to several conclusions of great practical importance. Let us suppose the forces  $P_1, P_2$ , &c., to be supplied by weights suspended at the angles of the polygon. It follows from the above, that if the weights  $P_1, P_2, P_3$ , were all suspended from the point  $P_3$ , as represented in the

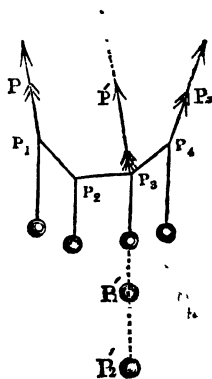
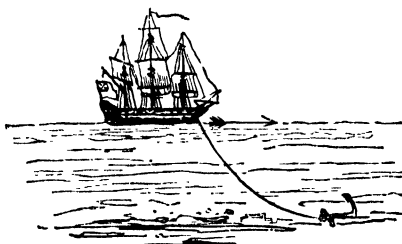



figure by  $P'_1$ ,  $P'_2$  and  $P_3$ , and the force  $P$  also applied at that point, in a direction  $P'$ , parallel to its present direction; then these would produce precisely the same tension in the string  $P_3$ ,  $P_4$ , as already exists there; and would indeed have that tension for their resultant. Hence, therefore, the greater and the more numerous are the weights on the branch  $PP_1$ ,  $P_2$ ,  $P_3$  of the polygon, the greater the tension upon the side  $P_3$ ,  $P_4$ . The tension on such a polygon, is, therefore, greatest about its points of suspension, and least towards the middle point between them.

#### THE CATENARY.

165. All this is true, whatever be the number of the sides of the polygon, and therefore if their number be infinite. In this case, the polygon will become a curve, and if the weights be equal to one another, and suspended at equal distances, it will be that formed by a rope or chain of uniform thickness, suspended by its extremities. Such a curved line is, therefore, more liable to break near its points of suspension than about its lowest point; and to be of equal strength, it should be made thicker there. It is called the catenary or chain curve. It is that formed by the cable of a ship at anchor.



upon the ship or the tension upon that part of the chain attached to it is, on the principles explained above, the same as though the horizontal resistance, supplied by the anchor, were immediately

applied to that point, and also the whole weight of the cable\* suspended freely from it. The curve of a line used for towing a barge, is a catenary. The force effective on the barge, is the same, as though the force exerted by the horse, were immediately applied to it in a direction parallel to that in which he draws, and, in addition to this, the weight of the cord suspended

\* The buoyancy of the water is not here taken into the account. Strictly, it is the weight of the cable, diminished by the weight of water which the cable displaces. In *hempen* cables this weight of water is nearly equal to that of the cable. In chain cables it is greatly *less*. The *hempen* cable scarcely, then, hangs in a curve at all, and can only yield to the motion of the ship as she rides at anchor by its *elongation*, whilst the chain cable hangs in a deep curve, and yields to the motion of the ship by tightening this curve. In this fact is a great advantage of the chain cable.

from it; the effective force is, in fact, the resultant of these two forces.

166. We have stated one condition of the equilibrium of a polygon of rods or cords, resulting from its identity with the equilibrium of a rigid system. There is this further condition, that if we take all the forces, excepting those which act upon the extremities of the polygon, and find the direction of their resultant, then the two extreme sides of the polygon, being produced, shall meet this direction in the same point. The reason of this is evident, for the system becoming rigid, we may substitute for the forces spoken of, their resultant, and the equilibrium will remain. The forces will then be reduced to three, two of which act in the directions of the extreme sides, and the third in that of the resultant; these must, therefore, meet in the same point (Art. 22.). Thus in the polygon, represented in the figure (1) loaded with the weights  $P_1, P_2, P_3$ , if we find the vertical  $RT$  passing through the centre of gravity of these weights, and produce  $PA$  and  $P_3B$ , these will meet  $RT$  in the same point  $T$ .

167. Similarly, in the funicular curve or catenary (fig. 2), if we draw tangents at the points of suspension  $A$  and  $B$ , these being in the directions of the forces sustaining the curve at those points, will meet when produced in the vertical line  $GT$  passing through the centre of gravity  $G$  of the curve.

Let us take  $GT$  to represent the weight of the curve  $AB$ , and draw  $GN$  and  $GM$  parallel to the sides  $BT$  and  $AT$ . The lines  $NT$  and  $MT$  will then represent the tensions. (Art. 21.) Thus  $GT$  being divided into as many equal parts as there are units of weight in the cord or chain  $BA$ , so many of those parts as there are in  $MT$  and  $NT$  will there be units of weight in the tensions at  $A$  and  $B$ . Now, as the cord is drawn tighter, the point  $G$  continually approaches it more nearly, and the line  $GT$  continually diminishes. And  $GT$  being divided always into the same number of equal parts (*viz.*, as many as there are units of weight in  $AB$ ), it is clear that these parts will continually diminish in magnitude. If, therefore,  $MT$  and  $NT$  remained the same, the numbers of

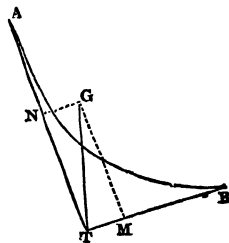
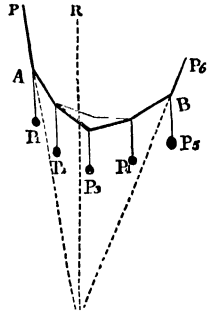



bridge is not so distributed on the chains. The suspending rods are, indeed, placed along it, at equal distances from one another, but the lengths of the portions of the curve included

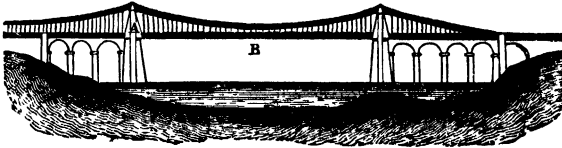

between these, are different; those about the lowest points of the chain only being equal to the included parts of the road-way, whilst those near the extremities are greater. Hence, therefore, the chains used in supporting the road-way of a bridge do not assume strictly the form of the catenary. Were the chain without weight, the pressure of the road-way upon it would, indeed, cause it to assume the form of the parabola. In reality it is a curve intermediate between the catenary and parabola, partaking of the properties of both.

• THE UPRIGHT POLYGON OF RODS.

170. WE have hitherto, in our discussions of the polygon of rods loaded with weights, supposed it to be *suspended*. All that has been stated obtains, however, equally with regard to a polygon in an upright position. All the difference in the cases consisting in this, that the strain upon the rods in the suspended polygon tends to lengthen them, whilst in the other it tends to compress them. Now, the *rod* is supposed to have the power of resisting one kind of strain, as firmly as the other.

In the one case the forces all act *from* the angles of the polygon, whilst in the other, they all act *towards* them. The case of the upright polygon is, therefore, precisely the same as though all the forces at each of its angles had their directions reversed. If they were in equilibrium before, that equilibrium will, therefore, *remain*.

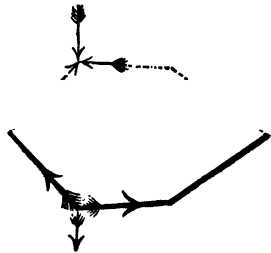

171. Hence, then, we deduce this important conclusion, that the position in which an *upright* polygon, loaded with weights, will stand, is that which it will assume for itself when loaded with the same weights and *suspended*.

172. We have supposed the rods of which the polygon is composed to be without weight. This can never be the case. Our supposition will not, however, introduce any inaccuracy in the calculation, if we add to the weight acting at each angle of the polygon, half the weights of the two rods which terminate there. For the weight of each rod (supposing it to be of uniform thickness,) has for its resultant a force acting in the vertical, passing through its centre of gravity, and this may be resolved into two other equal forces passing through its extremities.

173. We have thus a very easy way pointed out to us of determining, practically, the positions in which any number of beams should be arranged in a polygon so as to support one another. Let a cord be taken, and distances being measured along it, equal, respectively, in length to the sides of the polygon; let weights be attached to these, equal, each, to one-half the sum of the weights of the two adjacent sides. Then, the two ends of the string being held at a distance equal to the length of the base of the polygon, the form which the string will assume, when hanging freely, will be that in which the beams should be arranged.

#### ON THE EQUILIBRIUM OF A JOINTED FRAME OF RODS, OR A NETTING OF CORDS.

174. PRECISELY in the same manner as before, it may be shown that since all the conditions of the equilibrium of a rigid system must obtain in one of variable form; the forces acting upon the frame or netting ought to be in equilibrium if applied to a single point of it. (Art. 37.) And hence that those portions of such a netting or frame-work, loaded with weights, as are nearest the points of suspension are most liable to yield. Also that whatever form a jointed frame of rods takes when *suspended*, is that in which it will rest when placed in an *upright* position.

175. When a jointed frame or polygon of rods, loaded with weights, is suspended, its centre of gravity is at its *lowest* point, and its equilibrium is said to be *stable*; so that being moved out of its position it will return to it. It is not, therefore, necessary to the permanence of such a structure that its parts should be made rigid, or its angles stiffened. But if this figure be inverted, its centre of gravity will be at its *highest* point, and its equilibrium will become *unstable*, so that, being moved out of its position, it will not return to it, the whole figure collapsing, and falling to the ground.

To the continual equilibrium of an upright frame-work, it is therefore essential that its joints should be stiffened. Now this cannot be brought about by any peculiarity in the joint itself, for the different parts of such a joint, being situated exceedingly near to the centre about which each rod tends to move, are, on the principle of the lever, readily crushed by the action of a force, however slight, acting at the extremity of the rod. It is, therefore, requisite that each joint should be stiffened by subsidiary framing. And out of the necessity for this strengthening arises the greater economy of the suspended, than the upright polygon or framing. In the *suspended* polygon, or curve, the only precaution necessary, is that the parts should not *tear* asunder. In its *upright* position, their *flexibility*, as well as the chance of their *compression*, must be guarded against. Thus chain-bridges of iron contain less materials, and are far cheaper than iron arches. On the other hand, a serious difficulty arises in the use of the suspension-bridge, from its liability to motion. This will be explained when we come to treat of the science of Dynamics.

176. Besides its economy, arising from the small quantity of materials necessary for its construction, it is a prominent quality of the suspension-bridge, that it is independent of the bed of the river which it crosses. Hence it can be thrown over an opening where it is impracticable, either from the rapidity of the current, or from the altitude of the banks, to erect that frame-work called the *centering* which is necessary for supporting the parts of a *stone* or upright *iron* bridge, whilst the whole is being put together.

177. The methods of giving rigidity to a system of rods are various. They all of them, however, resolve themselves directly or indirectly into the arrangement of the component rods in *triangles*. Of all simple geometrical figures, the triangle is the only one which cannot alter its form without, at the same time, altering the dimensions of its sides\*; and which cannot therefore, yield, except by separating at its angles, or tearing its sides asunder. Hence, therefore, a triangle, whose joints cannot separate, and whose sides are of sufficient strength, is perfectly rigid. And this can be asserted of no other plane figure whatever. Thus a parallelogram may have sides of infinite strength, and no force may be sufficient to tear its joints asunder,

\* This at once follows from the proposition of Euclid, "that upon the same base, and upon the same side of it, there cannot be two triangles having their two sides terminated at one extremity of the base equal to one another, likewise their sides terminated at the other extremity."

and yet may it be made to alter its form by the action of the slightest force impressed upon it. And this is true in a greater or less degree of all other four-sided figures and polygons. It is for these reasons that in all framing care is taken to combine all the parts, as far as possible, in triangles. Which being once done we know that the rigidity of the system may be ensured by giving the requisite strength to the timbers and joints.

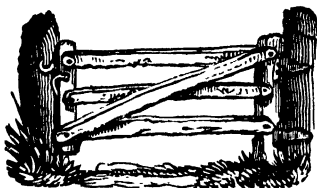
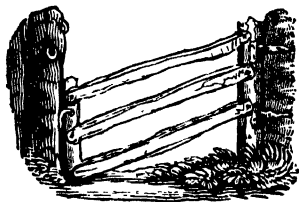

The framing of a gate presents a very simple illustration of this principle. The outline of the form of the gate is that of a rectangular parallelogram. If, as in the accompanying figure, the parts which compose it had been arranged in directions parallel to its sides only, so that the whole frame should have been composed of elementary parallelograms; each component parallelogram, and, therefore, the whole frame of the gate, would readily have altered its form.

A bar placed *diagonally* across the gate remedies the evil, converting the elementary parts of the gate from parallelograms into *triangles*, and thus giving perfect rigidity to the frame.

178. In the large frames called centres, used for supporting the stones which compose an arch, as they are separately put in their places, and *before*, by the introduction of the key-stone, they are rendered capable of sustaining one another, in the positions in which they have respectively been placed, by

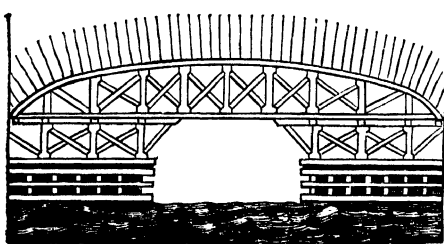

their mutual pressure; it is of the utmost importance that the most perfect rigidity should be ensured, under the enormous and unequal pressures to which the system is subjected.

All this is effected by giving great strength to the timbers of the centre, and ar-

ranging them in triangles well jointed together at their angles. The accompanying cut represents one of these employed in supporting the voussoirs of the great arch of London Bridge, whilst it was in the course of construction.

179. A triangular form is sometimes given to the parts of a framework supporting the parts of a wooden bridge, or a roof of wide span, by combining two or more

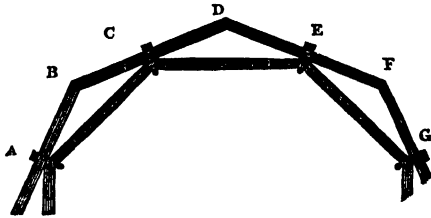

polygons of beams, as in the preceding cut, which represents a *principal*, or supporting frame of the roof of a shed in the dock-yard at Cherbourg. It is of very large span.

180. If we conceive the number of such polygons to be infinitely great, and the dimensions of the sides of each, infinitely small, our frame will become a continuous wooden arch, formed of short timbers bolted together, whose joints cross. This arch has of late years been largely introduced in the construction of roofs and bridges of large span.

In the roof of the military riding-house at Moscow there is one, which is 235 feet in span; and a bridge has been built over the Regnitz, at Bamberg, by Weibeking,\* which is 235 feet in span: this bridge is represented in the engraving. The largest wooden bridge ever erected appears to have been that over the Limmat, near the Abbey of Wittingen; it was *three hundred and ninety feet* in span.

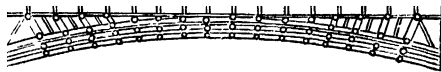

It was built in 1778, by two carpenters, brothers, of the name of Grubenmann, and was destroyed in the campaign of 1799. This extraordinary bridge was constructed upon the principle of the wooden arch.

Bridges of this kind may be built exceedingly flat. The bridge called the Oête, in Picardy, built by Coffenette, is 126 feet in span, and its crown is only 6 feet 3 inches above its springing. The bridge over the Schuylkill, in Philadelphia,

\* Some of the bridges of Weibeking are said to have fallen.



called the Colossus, is of the extraordinary span of 340 feet.



Its elevation above the springing is only 20 feet, and the width of the wooden framing of the arch at the crown 7 feet.

A bridge was built over the Piscatagua, near Portsmouth, in the United States, in 1796, which is supported by a single wooden arch 250 feet in span, and 27 in height.

CHAPTER XV.

- |   |                                 |
|---|---------------------------------|
| 182 Equilibrium of Solid Bodies in Contact. | 192 The Fall of the Arch.       |
| 185 The Arch.                               | 193 The Settlement of the Arch. |
| 187 The Line of Pressure.                   | 194 The Groin and Dome.         |
| 190 The Points of Rupture.                  | 195 The History of the Arch.    |

LET a solid body be acted upon by any number of forces,  $P_1 P_2 P_3 P_4$ , &c., and let these be such as would hold it in equilibrium.

The resultant  $R$  of any number of them,  $P_1, P_2$ , &c., being equal and opposite to that  $r_1$  of the remainder  $P_3, P_4$ , &c.

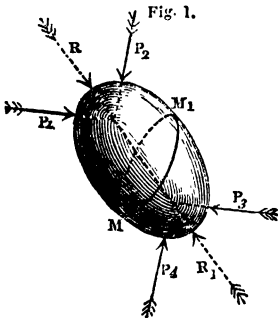

181. Suppose the body now to be intersected by a plane  $MM_1$ ; a question then arises as to the *further* conditions necessary, that the forces which held the parts of the body at rest when forming the same continuous solid, should continue to do so, now that it is divided into two separate solid bodies.

This question is of vast importance in the theory of construction, and we shall proceed to discuss it at some length.

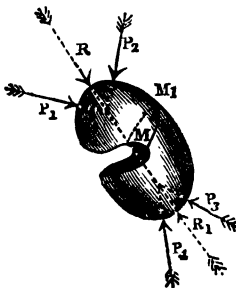

182. Let the forces, which act upon the two parts of the body, be supposed to be replaced by their resultants  $R$  and  $r_1$ , which are, by supposition, equal and opposite. Now the first condition requisite, is that the line in which  $R$  and  $r_1$  act should, when produced, pass through the plane of

intersection  $MM_1$ . For if it fall without that plane, as in the second diagram, it is quite evident that both portions of the body will revolve about the point  $M$ . The forces  $R$  and  $R_1$  are, in fact, to be sustained by the pressures on the different points of the surfaces in contact. These surfaces must, therefore, be such as that the resultants of the pressures upon their different points may be in a direction opposite to the forces  $R$  and  $R_1$ . Now these resultants manifestly lie *within* the boundary which includes the pressures themselves. If, therefore, the directions of  $R$  and  $R_1$  lie *without* this boundary, they cannot be sustained.

That the resultant of the pressures upon the surfaces which are in contact in  $MM_1$  should be opposite to the direction of  $R$  and  $R_1$ , it is not necessary that these surfaces should be *continuous*; they may, in fact, be applied to one another at any number of isolated points, the resultant of the pressures upon them having its direction, as stated above, through the space enclosed by a series of *straight* lines joining the extreme points of application; all that is requisite is that the direction of the forces  $R$  and  $R_1$  should be through this space. (Art. 56.) Thus the mass may be hollow, the surfaces of contact forming a continuous ring; or the one surface may rest upon projections from the other.

183. The above condition is not, however, the only one necessary to the equilibrium of the two bodies. It is further evidently necessary, that the direction of the resultants  $R$  and  $R_1$  should not make, with the perpendicular to the plane  $MM_1$ , an angle greater than the limiting angle of resistance; otherwise no resistance of the one surface can sustain the force impressed upon it by the other, and the two surfaces will slip along one another. (Art. 72.) These two conditions being satisfied (and the forces being further subject, according to our supposition, to the conditions required for the equilibrium of a continuous solid), the equilibrium will be complete. The applications of the principle we have stated are exceedingly numerous. Let us take one of the simplest.

184. Let it be required to determine in what directions the cylindrical shaft  $AB$  may be intersected through a given point  $P$ , so that the parts may retain their positions. In the first place, it is plain that the resultant of the forces acting upon the higher portion *intersects* the plane  $MM_1$ ;

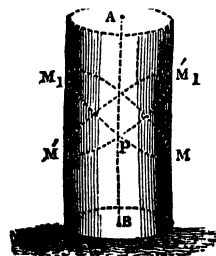

those forces being no other than the weights of its parts, and their resultant acting through its centre of gravity. There is, therefore, no possibility of this upper portion *turning over* on the edge of the lower.

To prevent the upper portion *slipping* on the other, no more is requisite than that the resultant, whose direction is thus vertical, should not make with the perpendicular to  $MM_1$ , an angle greater than the angle of resistance. We have before shown (Art. 79), that this will not be the case, so long as this plane is not inclined to the *horizon* at an angle greater than that angle. Draw then through the given point the planes  $MM_1$  and  $M'M'_1$ , inclined to the horizon in opposite directions, at angles equal to the limiting angle of resistance. Then the cylinder, being intersected in any direction intermediate between these, its upper portion will rest steadily upon the lower.

185. Next let us suppose the mass  $A_3 A B B_3$  (see the figure below), whose centre of gravity is in  $G$ , immediately above its base, and which, therefore, stands firmly when forming one continuous solid, to be intersected in the directions  $A_1 B_1$ ,  $A_2 B_2$ , and let it be required to determine under what circumstances the system of stones, thus formed, will rest. Take  $G_1$ ,

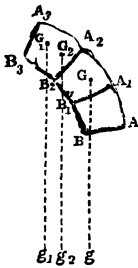

the centre of gravity of the highest stone, and  $G_2$ , the common centre of gravity of this stone and the one beneath it. Then it is necessary to the equilibrium; First, That the vertical  $G_1 g_1$  through  $G_1$  intersect the joint  $A_2 B_2$ , and that its direction lie within the limiting angle of resistance; or in other words, that  $G_1 g_1$  do not lie beyond the point  $B_2$ , or  $A_2 B_2$  be inclined to the horizon, at an angle greater than the limiting angle of resistance (Art. 79); for if this be not the case, the stone  $A_3 B_3 B_2 A_2$  will turn upon  $B_2$ , or slip down  $A_2 B_2$ . Secondly, This being satisfied, so that the first

stone may rest firmly upon the second, it is further necessary, that the vertical  $G_2 g_2$ , through the common centre of gravity  $G_2$  of the first two stones, should intersect the plane  $A_1 B_1$ , and that this latter plane should also be inclined to the horizon at an angle less than the limiting angle of resistance, otherwise the two upper stones will turn over on the point  $B_1$  or slip down the surface  $A_1 B_1$ . And, similarly, it may be shown, if the division be made into any number of parts, that taking the centre of gravity of the highest stone, the common centre of the two highest, that of the three highest, &c., and drawing vertical lines through these, such vertical lines must, in the First place, inter-



the forces acting upon the second voussoir in magnitude, and are perpendicular to their directions; therefore, if  $a b_2$  be joined it will represent the third force, *viz.*, the pressure upon  $A_2 B_2$  in magnitude, and be perpendicular to its direction.

If, then,  $m_1 m_2$  be produced to meet the vertical through  $a_2$  in  $m_2$ , and  $m_2 m_3$  be drawn perpendicular to  $a b_2$ , then will this line be in the direction of the resultant of the pressures upon  $A_2 B_2$ . And thus lines  $m_1 m_2, m_2 m_3, m_3 m_4$ , &c. may be drawn in the directions of the resultants of the pressures on the different joints. These form, together, a polygonal line, called the *line of pressure*. If the points  $n, n_1, n_2, n_3$ , &c. where the directions of the resultants  $m_1 m_2, m_2 m_3, m_3 m_4$ , &c. intersect the consecutive joints of the arch, be joined, the lines joining them will form the polygonal figure  $n n_1 n_2 n_3 n_4$ , called the **LINE OF RESISTANCE**\*.

187. It is necessary to the equilibrium of the structure, First, That the *line of resistance* lie wholly *within* the mass of the arch. For if at any point, as  $n_4$ , it cut the plane of any joint  $A B$  without the mass of the arch, the whole pressure of the superincumbent structure acts in the direction  $m_4 n_4$ , to turn it over on the joint  $A B$ , about which it will, therefore, necessarily revolve.

It is further necessary to the equilibrium, that the directions of the lines  $m_1 m_2, m_2 m_3$ , &c., in which the pressures at the different surfaces act, and which form together the line of pressure, should lie within the limiting angles of resistance at those surfaces. Now the lines  $a b_1, a b_2$ , &c., and the lines  $A_3 B_3, A_2 B_2$ , &c., would, if produced, make respectively with one another, the same angles which the lines  $m_1 m_2, m_2 m_3$ , &c. make with the perpendiculars to the surfaces of the joints, the former lines being respectively perpendicular to the latter. The above condition resolves itself, therefore, into this, that the lines  $a b_1, a b_2$ , &c., and  $A_3 B_3, A_2 B_2$ , &c., being produced, shall make respectively with one another, angles not greater than the limiting angle of resistance. If they are parallel to one another, or make no angles with one another, then the directions of the pressures  $m_1 m_2, m_2 m_3$ , &c., are perpendicular to the respective surfaces. And the stones would not slip even if there were no friction between them. That proportion in the dimensions of

\* The properties of the *line of resistance* were first given by the author of this work, in a paper read before the Cambridge Philosophical Society, in June, 1837. The analytical determination of it, and of the line of pressure, are contained in that paper, and in a paper published in the fifth volume of the *Transactions* of that Society, Part III.

the stones by which this direction of the pressure is brought about, is best calculated to ensure the stability of the structure.

188. To determine these dimensions, having taken the line  $ab$ , as before, to represent the horizontal force  $P$ ; dividing it into as many units of lengths as there are of weight in that force, we have only to draw through  $a$  lines  $ab_1$ ,  $ab_2$ , &c., parallel to the joints in succession, and ascertain the numbers of the above units of length in  $bb_1$ ,  $b_1b_2$ ,  $b_2b_3$ , &c. respectively. These numbers will give the units of weight which the voussoirs respectively must contain.

189. If the lines  $ab_1$ ,  $ab_2$ , &c., be drawn, making, with the joints, angles equal to the limiting angle of resistance, and the voussoirs be taken, as before, containing as many units of weight respectively as there are of length in the lines  $bb_1$ ,  $b_1b_2$ , &c.; then the directions of the pressures  $m_1m_2$ ,  $m_2m_3$ , &c. will make, with the perpendiculars to the surfaces of the joints, angles each equal to the limiting angle of resistance, and the stones will be upon the point of slipping *upwards*, if  $ab_1$ ,  $ab_2$ , make their angles with the joints, nearer to the vertical; and *downwards*, if further from it. The stones being taken of these dimensions, the structure is said to be in one of its states bordering upon motion. It will stand, so far as the friction is concerned, with any system of stones intermediate between these.

190. If we *imagine* the arch to be intersected by an infinite number of joints, the lines of resistance and pressure from polygons will become curves. The intersection of the line of resistance with each joint, will mark the *point* where the *resultant of the forces which act upon* that joint, intersects it; and a line drawn from this intersection so as to be a tangent to the line of pressure, will show the *direction* in which that resultant intersects it. It is evident that the situation of the line of resistance is dependent upon the magnitude of the force  $P$ . If that force be too great it will cut its exterior, and if too small, its interior, surface; and in either case, destroy the equilibrium. The *greatest* value of  $P$ , consistent with the equilibrium, is that which causes the line of resistance just to touch the exterior surface; and its *least* value that which causes it just to touch the interior surface. This last is the force which will just counteract the tendency of the structure to fall over towards  $P$ . Suppose this force  $P$  to be supplied by the equal tendency of another similar structure to fall in the opposite direction; the two will then constitute an arch.

191. The conditions of the equilibrium of the arch are then precisely those stated above, with this additional condition, that

the line of resistance *touches* its interior surface called the intrados, in certain points  $R$  and  $R'$  called the points of rupture, and that the pressure upon the key is the *least possible* which would support either semi-arch\*. The line of resistance cannot *cut* the intrados of the arch; for, if it were, the whole of that part of the semi-arch which is above the point of intersection would turn upon the joint next below that point. But this is impossible, for with whatever force this portion tends to revolve, it is resisted by an equal tendency to revolution in the other semi-arch.

Although the line of resistance cannot cut the intrados, yet it may be made to cut the extrados, or exterior surface of the arch.

192. Suppose it to cut the extrados in the points  $s$  and  $s'$ .

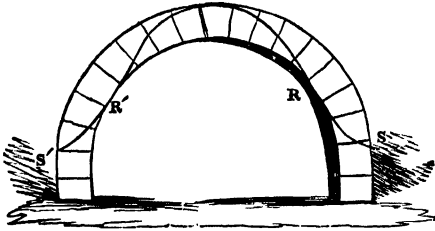

The *whole* force upon the arch, (including its weight,) acting as though it were concentrated in the resultants which pass through these points, it is manifest that the two portions of the arch above  $s$  and  $s'$ ,

yielding at the crown, will revolve outwards about the joints immediately below those points. But the arch thus yielding at the crown, its upper stones or voussoirs will have a tendency

to descend, turning about their inferior angles, and this tendency will be greatest at those points  $R$  and  $R'$  where the pressure is least effective to prevent that revolution. Thus, then, the arch will separate at

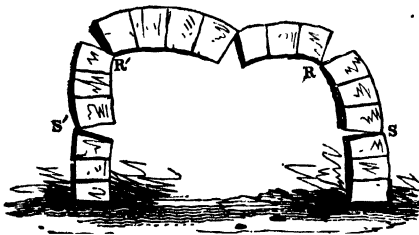

the crown, and at the joints immediately beneath  $R$  and  $R'$  and  $s$  and  $s'$ .

This is precisely what has been observed to be the process

\* This theory of the *points of rupture* and of the *minimum pressure*, was first given by the author of this work, in a paper published in the *Transactions of the Cambridge Philosophical Society*, Vol. V.

of the fall of the arch, in experiments made for the purpose of ascertaining it, by Monsieur Gauthey and Professor Robinson. The former gentleman caused the piers of old arches to be, on several occasions, cut through. Their fall was invariably observed to be attended with the phenomena described above. Professor Robinson caused models of arches to be made in chalk, and loaded them at the crown until the line of pressure cut the extrados, and they fell. These experiments were attended with precisely the same results.

It is evident that the material of the arch is most likely to yield at those points where the line of resistance most nearly approaches the intrados. Accordingly in Professor Robinson's experiments, the material was observed to chip and fall off there, before the final rupture. Having loaded his arches at the crown until they fell, he observed, however, that the points where the material began to yield, were not precisely those where the rupture finally took place. This fact presents a remarkable confirmation of the theory which has been stated in this chapter. It is manifest that, according to that theory, with any variation in the least force  $P$  (see fig. page 137), which would support the semi-arch if applied at its crown, there would be a corresponding change in the position of the point  $R$  and  $R'$ . Now, as the load on the crown is increased, this force  $P$  is manifestly increased. The result is, a variation in the form of the line of pressure tending to carry its point of contact with the intrados lower down upon the arch. This is precisely what Professor Robinson observed. The arch *began* to chip at a point about half-way between the crown and the point where the rupture finally took place.

The existence of points  $R$  and  $R'$  about which the two upper portions of the arch have a tendency to turn, and about which the material is first observed to yield, has long been known to practical men. The French engineers have named these, points of rupture of the arch, and the determination of their position by a tentative method, forms an important feature in the very suspicious theory which they have applied to this branch of statics.

193. It is apparent, by reference to the fig. page 140, that above the points  $R$  and  $R'$ , the direction of the line of resistance is such, as to indicate a direction of the pressure which would produce in the arch-stones a tendency to slide *downwards* upon one another, whilst below that point the tendency is to slide *upwards*. Hence, therefore, it might be expected that when the centre of an arch was removed, the motion of the arch-stones (since they would then admit of some degree of motion



among one another, by reason of the yielding of the cement, or, if no cement be interposed, by reason of the closer degree of contact into which the additional pressure would not fail to bring them,) would be slightly downwards in reference to those voussoirs which are above the points  $r$  and  $r'$ , and upwards in reference to those which are *below* those points. This motion of the voussoirs amongst themselves, on the removal of the centre, produces what is called the *settlement* of the arch, and this settlement is observed to take place precisely under the circumstances above described.

The celebrated French engineer, Perronet, has left us a detailed account\* of the circumstances which attended the striking of the centres of a number of large arches constructed under his directions. At the bridge of Nogent, before removing the centre of the arch, he caused three lines to be cut upon the *face* of it; one *horizontally*, immediately above the crown, and the other two lying *obliquely* from the extremities of this, on either side, towards the springing of the arch. After the striking of the centre, these lines were observed greatly to have altered their forms, and even their relative positions on the face of the arch. All of them had, from straight lines, become curves. The horizontal line had *sunk* throughout its whole length; its greatest deflexion being immediately above the key, thus indicating a downward motion in all the voussoirs on which this line was traced. The oblique lines, too, had, on either side, deflected from their first position *towards* the intrados of the arch, or *downwards*, up to *certain points* corresponding to  $r$  and  $r'$ ; beneath these points the deflexion was *from* the intrados of the arch, or *upwards*.

Thus, among the voussoirs on which the oblique lines were cut, there was shown to be a *downward* motion in respect to those above the points corresponding to  $r$  and  $r'$ , and an *upward* motion in respect to those beneath those points. Precisely the same phenomena were observed to attend the settlement of the other great arches constructed by Perronet, especially those of the Pont de Neuilly.

#### THE GROIN AND DOME.

194. THE theory of the equilibrium of the groin and that of the dome are precisely analogous to the theory of the arch. In the groin a mass springs from a small abutment, spreading itself out symmetrically with regard to a vertical plane passing through the centre of its abutment, until at length it meets an

\* *Mémoire sur le Cintrement et Decintrement des Ponts.*

equal and similar mass springing from an opposite abutment. It is, in fact, nothing more than an arch whose *voussoirs* vary as well in *breadth* as in *depth*. The centre of gravity of the different elementary *voussoirs* of this mass lie all in its plane of symmetry. The line of pressure is, therefore, in that plane, and its theory is embraced in that which we have already laid down.

Four groins commonly spring from one abutment, each *opposite* pair being *adjoined*, and each *adjacent* pair uniting their margins. They thus lend one another mutual support, and form a continued covering. The groined arch is of all arches the most stable, and, could materials be found of sufficient strength for its abutments, and the parts about its springing, it might safely be built of any required degree of flatness, and spaces of enormous dimensions might readily be covered by it.

It is remarkable that modern builders, whilst they have erected the common arch on a scale of magnitude nearly perhaps approaching the limits to which it can be safely carried, have been extremely timid in the use of the groin.

195. If, instead of the mass springing from a small abutment, and gradually spreading out its surface, so as to cover a wider space, we suppose it to spring from an extended base, and to contract its lateral dimensions as it ascends, until, as in the groin, it meets and rests against the crown of a similar and equal mass springing from an opposite abutment; and if we suppose a number of such masses to spring from different abutments placed side by side, and to unite their margins, the whole will form a dome. The theory of the dome is thus clearly analogous to that of the arch and groin.

#### THE HISTORY OF THE ARCH.

196. THE first bridge was probably a tree which had fallen from one bank to the other of some mountain-torrent. The method of communication thus supplied by accident, men would soon learn to obtain for themselves, by the rude resources of art; and ere long the opposite banks of rivers would come to be connected by means of timbers, or flag-stones, supported upon piers. The application of this notion of a bridge seems to have constituted the whole art of bridge-making up to a comparatively recent period in the history of mankind. Yet it is altogether inadequate to the passage of deep or rapid currents, and fatal to navigation. Accordingly, we find that the Egyptians, although they swarmed along both banks of the Nile, never built for themselves a permanent bridge across it. The Tigris, too, and

the Euphrates, on whose banks dwelt that other enterprising and highly-polished nation of remote antiquity, the Chaldees, were bridgeless\*. And even in the age of Pericles, there was no stone bridge over the river Cephissus, at Athens.

Necessity is said to be the mother of invention : there are certain matters in which she has been exceedingly slow in coming to the birth. The discovery of the arch is a memorable example. The Egyptians, Chaldees, and Greeks, were all admirable masons ; yet they never learned how to make an arch†. Of Europeans, the first who appear to have made the discovery were the Etruscans ; and the earliest existing specimen of the arch is said to be found among the ruins of the Etruscan town of Volaterra‡.

To the Chinese, the secret of the arch appears to have been known from time immemorial. In fact, it is difficult to fix upon any useful contrivance which is not at present, in some degree, known to that singular people ; or any period in history when they did not know it. They certainly used the arch long before it was thought of in Europe. It covers the gateways in their great wall ; they availed themselves of it in the construction of monuments§ to their illustrious dead, and in the formation of their bridges. Kircher, in his *China Illustrata*, tells us of stone bridges in China three and four miles long, and an arch of the incredible span of six hundred feet.

From the Etruscans, the secret of the arch passed to the Romans ; and was soon employed in the construction of bridges over the Tiber. Of these several remain ; they are, however, but awkward specimens of the art of bridge-making. Their narrow arches are supported upon huge unsightly piers, which form a serious obstruction to the current ; and they thus involve a principle of weakness in their very strength. The Romans have, nevertheless, left us, in other parts of their dominions,

\* They had bridges of boats.

† It is necessary to qualify this assertion. Brick arches are said to have been found buried in the tombs of Thebes. Mr. Hoskins describes one eight feet six inches in span, and regularly formed. Among the ruins of Meroë, the ancient capital of Ethiopia, he found a semicircular arch of stone covering a portico, and at Gibel el Berkel a pointed arch, forming the entrance to a pyramid. It is most remarkable that the secret of the arch should not have passed from Ethiopia, or from the tombs of Thebes, into the architecture of Egypt.

‡ Micali, *Antichi Monumenti*.

§ Monumental and triumphal arches are said to be scattered in such numbers over the face of the country as to give a character to the scenery. It is remarkable that the arch should have been erected in honour of illustrious men both by the Chinese and the Romans.

bridges of extraordinary strength and great beauty. Of these, that of Alcantara is perhaps the most remarkable: its road-way is 140 feet above the level of the stream which it crosses, and its arches 100 feet in span. It was built by Trajan; under whose reign was also erected a bridge over the Danube, of which many incredible things are told by Dion Cassius; and of which nothing is to be seen, but now and then the foundation of a pier. He built it that he might conquer the Dacians; his successor destroyed it, that he might restrain their incursions into the empire.

In those troublesome times which succeeded the fall of the Roman empire, no bridges were built. Rivers were, for the most part, passed by fords or ferries; these frequently became subjects of contention between neighbouring barons, or were taken possession of by outlaws; and travellers, in availing themselves of an insecure method of transfer, were subjected to the certainty of being heavily taxed, and the chance of being plundered.

It was about the commencement of the twelfth century, that one Benezet, a cow-herd, appeared in the Cathedral of Avignon, and announced to the multitude a special mission from heaven for the erection of a bridge over the Rhone at that city. By efforts little less than miraculous, this singular enthusiast contrived, in the course of a few years, to erect a bridge which, whether we consider it in reference to its enormous dimensions, or the local difficulties to be overcome in its construction, claims to be ranked among the most remarkable monuments that have ever been raised by the skill and ingenuity of man. Unfortunately, a flood of the Rhone carried it away. The labours of Benezet did not, however, altogether disappear with his bridge; he obtained a place among the saints of the Roman Calendar, and became the founder of a religious order, called the Brethren of the Bridge, by whom some of the finest bridges in Europe have been erected.] Of these, that of Saint Esprit on the Rhine, is not far short of a mile in length, and that called La Vieille Brioude\*, over the Allier, is a single semicircular arch of 180 feet in span, and until the erection of the Chester Bridge, which is 200 feet in span, the largest arch. Of the same date was the old London Bridge, the work of Peter of Colechurch: it would, however, greatly suffer by comparison with the labours of the Brethren of the Bridge. From this period up to the present,

\* This bridge, inconvenient by reason of its narrowness and its great elevation, has of late years been replaced by a more commodious, but not a bolder or more remarkable structure.

the art of bridge-making has continually progressed, and most of the rivers of the Continent are now spanned by arches, with which the labours of former ages will bear no comparison, either as it respects the boldness and grandeur of their design, or the perfection of their detail.

The art appears to have attained its perfection in the magnificent structures which have of late been erected across the Thames, and in the great arch of Chester. These have no parallel.

## CHAPTER XVI.

- |   |  |
|---|--|
| 98 Elasticity.'   | 209 On the Measure of Elasticity—the Modulus of Elasticity.  |
| 200 Method of ascertaining the law of Elasticity, by Torsion.       | 210 On <i>direct</i> Compression or Extension—the disturbing force must be applied through the Centre of Gravity of the Section. |
| 202 Experiment proving the existence and law of Elasticity in Lead. | 211 On <i>oblique</i> Compression or Extension.  |
| 204 Ductility.  | 212 The Neutral Axis and Neutral Surface.  |
| 205 Permanent alteration of Internal Structure.                     |  |
| 208 Extent to which the property of Ductility may be developed.     |  |

### ON THE STRENGTH OF MATERIALS.

197. IN the preceding part of this work we have supposed the various solid bodies, the conditions of whose equilibrium we have discussed, to be composed of parts incapable of separation or displacement. A solid body thus defined, has, however, no existence in nature, and is altogether a philosophical abstraction. The bodies around us are all, in their nature, more or less *yielding* and *compressible*\*; and the parts of all of them appear to admit of a certain degree of *displacement* and *separation*.

From numerous experiments which have been made upon the strength of materials, it appears that the displacement of the particles of solid bodies is subject to the following laws:—

\* The *incompressibility* of certain substances has been asserted, and among the rest, of water. It is told of certain academicians of Florence, that having enclosed water in a hollow sphere of gold, and closely soldered up the opening by which it was introduced; they hammered the sphere, and found, that rather than diminish its bulk, the water forced its way through the minute pores of the metal. It has since been completely ascertained, that water admits of compression. Ørsted has, by a most ingenious contrivance, succeeded in measuring the amount of this compressibility; and there is every reason to believe, that it possesses this property of compressibility in *common* with all other material substances.

198. First, That when this displacement does not extend beyond a certain distance, each particle tends to return to the place which it before occupied in the mass of which it forms a part, with a force exactly proportional to the distance through which it has been displaced. Secondly, That if this displacement be carried beyond a certain distance, there is no tendency in the particle to regain its former position, and it remains passively in the new position which it is made to take up, or takes up some other position different from that from which it was originally moved.

The effect of the first of these laws, when exhibited in the *joint* tendency of the particles which compose any finite portion of a mass, to return to any position in respect to the rest of the mass, or in respect to one another, from which they have been displaced, is called *elasticity*. There is every reason to believe that it exists in all bodies, within the limits, more or less extensive, which are imposed by the second law stated above.

199. It is impossible, by any *direct* process, so to displace any one of the particles of a body, through a portion of that very minute space within which the law of perfect elasticity obtains, as to measure the force with which it endeavours to return to its first position, and ascertain, *directly*, whether that force be, or be not, proportional to the displacement. There are, however, several *indirect* methods by which we may produce the requisite displacement, and measure the force produced by it. Of these, the following is, probably, the simplest and the best.

200. Let a thin cylinder, or wire, of the substance to be examined, be taken, and let it be conceived to be divided into any number of exceedingly narrow elementary cylinders, or laminae, formed by imaginary transverse sections of the wire made exceedingly near to one another. Let the wire then be twisted once round; it is evident that each of the laminae will be made, by the twisting of the whole wire, to move through the *same distance* on the lamina immediately above it. For there is no reason why one should thus be moved further than the other. Also, it is evident that, if we take the displacement of each lamina upon that above it, beginning from the top, and add all these displacements together, their sum should be exactly the one revolution which the lowest lamina of the wire is made to describe. Thus the angle through which each lamina is made to revolve upon the surface of that above it may be found by dividing one revolution, or four right angles, by the

number of laminae\*, Or the *actual distance* through which each particle on the *surface* of the wire is made to move, may be found by dividing its circumference or girth by its length; and supposing the thickness of the wire to be made up of similar cylindrical surfaces concentric with its *external* surface, the actual displacement of a particle contained in any of these will be found by dividing *its* circumference similarly by the length. Thus it is apparent, that when the wire is twisted, *each of its particles* sustains a certain displacement dependent for its magnitude upon the depth of that particle beneath the surface of the wire.

Now if the whole of a mass so twisted when left to itself, *return to its first position*, it follows that each particle, whatever the distance through which it may have been moved, must have returned also precisely to its first position in respect to the particles immediately adjacent to it. Also if the whole mass tend to return to the position out of which it has been distorted with a force proportional to the angle of torsion; it follows, that each particle in it tends to return to the position out of which it has been displaced, with a force proportional to the distance through which it has been displaced. For suppose the whole to be made up of *hollow* concentric cylinders or tubes, and consider any of these separately; it is evident that the actual displacement of each of its particles is the *same*; therefore, the *whole* displacement is proportional to the displacement of any one particle of the cylinder. It is also evident that the *force* producing the displacement of each particle of the cylinder is the *same*; therefore, the *whole force* displacing the cylinder, is proportional to that producing the displacement of each particle. It follows, that if the *whole* force be proportional to the *whole* displacement which it produces, then each component force is also proportional to that portion of the whole displacement which *it* produces.

Now the whole displacement of the parts of the hollow cylinder or tube, is proportional to the angle through which the tube is twisted. If, therefore, the twisting force is proportional to this angle, it follows, from what has been said, that the force producing the displacement of each particle, is proportional to that displacement. Let us suppose tubes, similar to the above, to be placed within one another, so as to fill up a cylinder, and let forces be applied to each of these, twisting it through the

\* From this it is evident, that by increasing or diminishing the length of the wire, we may vary the amount of the displacement of each particle to any extent we may choose.

*same* angle. Then if the *sum* of these forces be proportional to that angle, it follows that *each* of them is proportional to it; and if this be the case, it follows, from what we have just said, that each particle is displaced with a force proportional to its displacement. But the sum of the forces producing the displacement of the elementary tubes is the same as the force displacing the *solid* cylinder. Hence, therefore, it follows, that if this force be proportional to the angle of torsion, the law of perfect elasticity obtains with regard to the particles which compose the cylinder, each endeavouring to return to its first position with a force proportional to the distance through which it has been moved.

201. The conditions supposed above, and shown to imply that condition of perfect elasticity within certain limits, which we have stated at the commencement of this chapter; are precisely those which have been proved to obtain with regard to all those solid bodies which have hitherto been submitted to experiment. There are certain bodies in which they are at once recognized, as for instance in steel, and in various kinds of wood; there are, however, others, in which elastic properties are by no means so apparent. We will take an example from this latter class.

202. Let a *lead*\* wire be taken, one-fifteenth of an inch in diameter, and ten feet long; fix one end firmly to the ceiling, and let the wire hang perpendicularly; affix to the lower end an index like the hand of a watch; on some *stand* immediately below, let there be a circle divided into degrees, with its centre corresponding to the lowest point of the wire. Now let the wire be twisted twice round, and then let go. The index which was twisted with the wire twice round the circumference of the circle will be at once observed to return and make almost four revolutions, that is, two revolutions backwards, or beyond its first position; it will then again return in the direction in which it was distorted, and after oscillating backwards and forwards a considerable time, each oscillation diminishing in amplitude, it will finally rest precisely in its first position. Further, if the forces with which the needle, when twisted through different angles, tends to return to its first position, be accurately

\* Experiments have been made of a similar kind to that described above, with a great variety of different substances, and these tend to show the existence of elastic properties, where it would be least expected. A thin cylinder or wire of pipe-clay, for instance, will, when subjected to torsion, as described above, exhibit properties showing the existence of as perfect an elasticity among its particles as can be found among those of the hardest steel. The limits of elasticity being, of course, different in the two cases.



measured, these will be found to be accurately proportional to the angles of distortion\*.

203. Now let the wire be twisted round four times instead of twice. If then left to itself, it will oscillate, as before, and finally rest; but it will be found not now to have rested in the position out of which it was first displaced, but to be short of that position by nearly two revolutions. The particles of the wire have, therefore, now, some of them been displaced so far, that they will not return to their original positions, and a new arrangement has taken place among them: those about the centre, having been only slightly displaced, have probably *wholly* returned; those more remote from it have continually suffered more and more permanent displacement, until, at the circumference, the displacement is equal to twice the circumference of the wire divided by its length. The wire is, under these circumstances, technically said to have taken a *set*.

204. It is remarkable, that after this alteration of the relative positions of the particles, they seem to have retained the same relation to one another as before. Each particle is affected by the particles among which it has now taken up its position, precisely as it was by those which it has left, for if, after it has taken a *set*, we twist it again, and thus try its elasticity, we shall find that elasticity as perfect as at first. This property by which the particles of a mass may be moved among one another, passing in each new position into the same relation with respect to the particles which surround them in that position, as they had in reference to the particles which were adjacent to them in any previous position, is called *Ductility*. The preceding experiment thus exhibits to us two of the most important properties of solid bodies.

First, their elasticity, resulting from the tendency of each particle to return to any position out of which it has been displaced, with a force proportional to the displacement. Secondly, their ductility, being that property by which this displacement when it is made to take place within certain limits, and under certain circumstances, becomes in a measure *permanent*, the displaced particles taking up new positions in the mass, and entering into the same relation in reference to the particles which now surround them, as obtained in regard to those which surrounded them before.

205. We have stated, that the displacement, which calls

\* So accurately is this the case, that balances intended to measure forces far too minute to be measured by the common balance, have been constructed on this principle. These are called Torsion Balances.

into existence this property of ductility, must take place within certain limits, and under certain circumstances. If the displacement be less than is necessary to bring it within those limits, the particle will, in virtue of its property of elasticity, return accurately to its first position, and rest there. If the displacement of the particle be too great to lie within the limits of ductility, it will *not* again enter into the same kind of relation with the particles lying in the direction from which it has moved as it had before its displacement; a partial separation of the mass will, in fact, take place, so far as this particle is concerned, and a permanent alteration in its internal structure. This alteration of internal structure occurring in reference to any considerable number of the particles which compose the mass, will materially affect its strength. It may, nevertheless, take place without there being presented on the surface of the mass, any indications of the change which have taken place within it. Thus, if a cannon be fired with a charge of powder, producing a strain above\* the elastic force of certain portions of the material of which it is composed, a permanent alteration of its structure will be the result, and a second discharge will burst it. It has been stated, that a cannon of large dimensions, so overstrained by an excessive charge, may be broken in pieces by a single blow from a sledge-hammer. On the same principle, a wire may be broken by frequently bending it backwards and forwards. At each flexure, a permanent alteration of structure takes place with regard to certain of the particles which compose the section about which it is bent. Certain of these separate from one another; and by repeated flexure, this separation may be extended completely across the whole wire. An alteration of internal structure, appears to be brought about in some bodies by the influence of time alone. Thus *stone* is exceedingly uncertain in strength; an alteration of this kind proceeding *continually* in it, the effects of which are not apparent until after a great number of years.

206. The properties of elasticity and ductility, in virtue of which the particles of bodies may be made to suffer displacement without any permanent alteration of the internal structure, are *practically*, among the most valuable properties they possess. We have before remarked, that the destruction of *force* of that kind which is contained in a *moving body*, and which is exerted in *impact*, cannot take place, except with a certain degree of

\* The strain which produces permanent alteration of internal structure varies from one-fourth to two-fifths of that necessary to produce absolute rupture.

yielding in the parts of the mass on which it is made to impinge. Since, therefore, the parts of bodies necessarily *yield* to every force in the nature of impact which is impressed upon them, it follows that were any such *yielding* or *displacement* of their particles, necessarily attended with a permanent alteration of structure, few of the masses around us could for any considerable time retain their form; since there are few, if any, which are not occasionally subjected to the action of certain impinging forces. A shower of hail, or even of rain, would be sufficient to reduce every thing on the earth's surface to powder; nothing we put out of our hands would be able to sustain the slight impact which it could not fail to receive when we released our grasp, and the substance on which we placed it, would be dashed to atoms; substances might be found sufficient to sustain the pressure of a man's weight when *standing* on them at rest; he could not, however, move about upon them with safety.

207. The best method of bringing into operation the property of ductility, is probably that of impact. By varying the amount of the impinging force we may readily produce that amount of displacement in the particles of a body, which is just necessary to give them what is technically called *a set*; and the body having, under these circumstances, precisely the same properties as before, the blow being repeated, a further displacement within the limits of ductility may be produced, and thus it may be moulded into any required form, and spread over almost any required surface. The property of ductility, when thus developed by impact, is called malleability. It may be exhibited in certain of the metals, as for instance, gold, to a wonderful extent.

208. Another method of calling into action this property of bodies, and especially of metals, is that adopted in the making of wires. The following is an example, taken from the works of Réaumur. The gilt threads used in his time in embroidery, and in gold lace, were thus made. A cylinder of silver, of the weight of 360 ounces, was covered with a plate of gold, weighing, at most, six ounces. The whole mass, thus weighing 366 ounces, was then drawn through a series of holes made in broad steel plates, and gradually diminishing in diameter; until passing through the last, it was converted into a wire of such a length, that 202 feet\* of it weighed only 1-16th of an ounce, so that its whole length was 1,182,912 feet, or 98,576 French leagues. This wire was then passed between rollers, which

\* All the above are French measures.

flattened, and, at the same time, lengthened it 1-7th. Thus its length became 1,351,900 feet, 112-66 French leagues; being more than the distance from Paris to Lyons. The thread was then 1-96th of a line in *width*; and, admitting with Réaumur, that a cubical foot of gold weighs 21,220 ounces, and a cubical foot of silver 11,523 ounces, we find that its *thickness* could not be more than 1-3108th part of an inch. What, then, must be the thickness of the stratum of gold which covers its sides and its edges? By calculations analogous to the above, we find that the thickness of this layer of gold cannot be more than the 1-713,136th part of an inch. Nevertheless, gilt wire is made, in which only one-third of the quantity of gold which we have supposed is used. It is impossible to carry our notions of the ductility of matter further than this. It is probable that all bodies possess more or less of the properties of elasticity and ductility: the proportions, however, in which these properties exist in them, are exceedingly various\*. Those which are the most elastic, are by no means the most ductile; the contrary seems, in fact, to be the case; those bodies which are the most ductile being commonly the least elastic.

209. It has been shown that the particles of solid bodies tend to return to any position out of which they have been moved, with a force proportional to their displacement; if, therefore, we represent by the letter  $M$ , the force requisite to displace the particles composing an unit of the bulk of any given solid body through a distance equal to unity†, then the force requisite to produce a displacement of the same unit through a distance of  $D$  units or parts of unity, will equal  $D$  times  $M$ ; call this force  $f$ .  $f = MD$ . As will be shown hereafter, there are a great variety of ways of determining the amount of the force  $M$ . The following, when it can be effected, may very well answer the purpose. Let a rod be made of the substance whose modulus  $M$  is to be determined, having a section equal to  $\kappa$  square units, and being  $L$  units in length. And, any

\* It is a curious fact, that by *forging* a metal, or drawing it frequently like a wire, its *cohesion* (that is, the force with which it resists *absolute rupture*) is greatly increased. Thus lead, although it is made *less dense* by drawing, may have its cohesion *tripled*.

† That is, the force sufficient to cause one solid unit to occupy a space equal to two solid units. Or, which would equal that force, provided the material could be displaced through that distance, subject to the same law which at present governs its tendency to recover its position. With this condition the force  $M$  may be understood to apply to the case of *compression* as well as extension.

given force  $F$  being applied to lengthen or compress this mass, let the corresponding alteration of length be observed; call this  $l$ . Now the tension *throughout* the mass is the same. Every transverse section of it is, therefore, acted upon by a force equal to that force  $F$ , which is applied to its extreme section. And every *unit* of such a section is acted upon by a force equal to  $\frac{F}{K}$ . Also the extension or compression of the whole  $L$  units of length being  $l$ , *each* unit of length is extended or compressed through a space equal to  $\frac{l}{L}$ . Now  $M$  is the force producing each unit of extension or compression on an unit of area, and an unit of length. Hence, therefore, the force necessary to produce the whole of it on such an unit is,  $\frac{M l}{L}$ .

But the force really acting on an unit of the area of each section and producing this extension or compression, has been shown to be  $\frac{F}{K}$

$$\therefore \frac{F}{K} = \frac{M l}{L} \quad \text{and} \quad \therefore M = \frac{F L}{K l}.$$

If  $E$  be the height in feet of a prism, or bar of any substance, the weight of which prism equals the value of the force  $M$  corresponding to the elasticity of that substance, and which has transverse section of one unit in area, then calling  $w$  the *weight* of one foot of this bar, we have,  $w E = M \quad \therefore E = \frac{F L}{K L W}$ .

$E$ , being thus taken, is called the **MODULUS OF ELASTICITY**.

The table at the end of this chapter contains the values of the *Moduli of Elasticity* and of the force  $M$ , as determined by experiment from a variety of different substances. It is found that for compression, these are generally less than for extension.

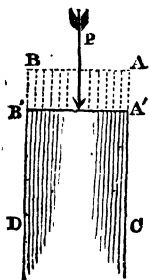

210. Let us suppose an elastic mass  $AB CD$ , terminated by a rigid plane  $AB$ , to be acted upon by a force  $P$ , causing this plane to move parallel to itself into the position  $A'B'$ . Each unit of the mass being then equally displaced, the whole force  $P$  necessary to produce this displacement, will equal the force  $M$ , multiplied by the units in the space between  $AB$  and  $A'B'$ , or if  $K$  be the area of the plane  $M \times K \times \overline{AA'} = P$ ;

whence it follows that,  $\Delta A' = \frac{P}{M K}$ .

Since the force acting upon every point of the plane  $A'B'$  is proportional to the *compression* of the material immediately beneath it, and that this compression is every where equal to  $\Delta A'$ ; it follows that the pressure upon every point of that plane is the same. Hence, therefore, an *uniform* plate of any heavy substance might be taken of such a thickness, that having precisely the same form and dimensions with the plane  $A'B'$ ; the weights of its parts should be precisely analogous and equal to the pressures sustained by the different points of that plane. Now the resultant of the weights of the parts of the plate would pass through the centre of gravity of the plane  $A'B'$ ; the resultant of the pressures upon that plane passes, therefore, through the same point; hence, therefore, the force  $P$  must act through that point. To produce, therefore, that motion of the plane  $AB$ , parallel to itself, which we have supposed, it is necessary that the force  $P$  be made to act through the centre of gravity of that plane. If the force  $P$  do not act through the centre of gravity of the section  $AB$ , the latter will be made to take up an oblique position  $A'B'$ .

211. This oblique position *may* intersect its previous horizontal position. Throughout the line of intersection the mass will sustain neither extension nor compression, and it is thence called the *neutral axis* of the section. Its projection is represented in the accompanying figure at  $N$ . In altering its position, the plane  $AB$  has compressed the material lying between  $NB$  and  $NB'$ , and extended that between  $NA$  and  $NA'$ . If the mass be bent throughout its whole length, *every* transverse section of it will thus be made to intersect, in the new position which it is thus made to take up, with the position which it occupied before\*; every such section has thus a neutral axis, and the surface in which all these lie, is the *neutral surface* of the mass. The strength of the material would not,

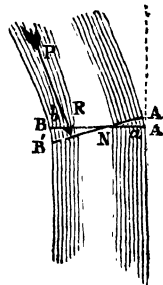

\* It does not follow that the points which lie in any plane transverse section of the mass before it is bent should be also in a *plane* after it is bent; the general case appears to be that they will not.  $AB$  in the figure must then be supposed to represent, not a plane, but a curved surface. This consideration is *opposed* to the theory of deflexion, usually given in mathematical works, and it would seem, fatal to it.

evidently be essentially impaired, by removing that portion of it which lies immediately contiguous to this surface.

212. Let us now consider the circumstances which may enable us to determine the *position* of the neutral axis. It will be observed that the forces which hold the plane  $A'B'$  at rest, are the force  $P$ , and the elastic forces called into action by the compression of the mass between  $NB$  and  $NB'$ , and the extension of that between  $AN$  and  $A'N$ . Now these elastic forces are, at the several points of  $A'B'$ , proportional to the distances through which the extension or compression has at those points taken place; that is, drawing lines from these points perpendicular to the plane  $AB$ , the corresponding forces are severally proportionate to those lines. Now a *heavy mass*, precisely of the dimensions of the space included between the planes  $NB$  and  $NB'$ , would press upon the different points of the latter plane, by reason of its weight, with forces exactly proportional to the lines of which we have above spoken. Such a heavy mass might, therefore, be taken, as would, by its weight, exactly replace the elastic forces upon  $NB'$ . And, similarly, a heavy mass exactly of the dimensions of the space included between  $NA$  and  $NA'$ , might be so taken as to replace the forces acting on  $NA'$ ; only its gravity must be supposed to act *upwards* instead of downwards. Each of these masses will be of uniform density throughout, but the two will be of somewhat different densities, by reason of the inequality of the moduli of extension and compression.

Since, then, the forces acting upon the different points of  $A'B'$  are identical with the weights of the parts of certain uniform masses, of the dimensions of the spaces included between that plane and  $AB$ ; it follows that the resultants of these forces pass through the centres of gravity of those masses. Thus, the resultant of the forces upon the plane  $NB'$ , passes through the centre of gravity of the mass  $NBB'$ , and the resultant of the forces upon  $NA'$  passes through the centre of gravity of the mass  $AN A'$ . Let  $a$  and  $b$  be the points where the resultants of the forces upon  $NA'$  and  $NB'$ , respectively, intersect the plane  $AB$ ; also let the direction of  $P$  intersect this plane in  $p$ , (see the figure on the next page,) and let  $M$  be the centre of gravity of the plane. Then calling  $m$  and  $m'$  respectively, the weights of units of the masses which may be taken to replace the forces upon  $NA'$  and  $NB'$ , respectively, we have, by the general conditions of the equilibrium of a system of parallel forces, (Art. 46.)  $P + m \times (\text{mass } N A A') = m' \times (\text{mass } N B B')$ ; also (Art. 45.)

$P \times M p = m \times (\text{mass } N A A') \times M a + m' \times (\text{mass } N B B') \times M b$ .  
Which two conditions are sufficient for the mathematical determination of the position of the neutral axis.

213. If the mass be rectangular, or the section  $AB$  a rectangle, and if  $A'B'$  be considered a *plane* (an hypothesis generally made),  $M$  will coincide with the intersection of its diagonals and lie in the axis of the mass, and it will be found that  $MN$ , or the distance of the neutral axis from the axis of the mass, equals the square of the *line*  $AA$  divided by twelve times the distance  $M p$ , or

$$MN = \frac{A B^2}{12 M p}.$$

Hence if  $M p = \frac{1}{3} M B$ , or  $= \frac{1}{3} A B$ ; then  $MN = \frac{1}{2} A B = M A$ .

In this case, therefore, the neutral axis is in the surface of the beam at  $A$ . Since here the mass  $N A A'$  vanishes, it follows that,

$$P = m' \times (\text{mass } N B B'); \therefore P = \frac{1}{2} m' A B \times B B',$$

where  $B B'$  is the greatest compression. Now in the case of direct compression, (Art. 210.)

$$P = m' \times A B \times (\text{direct compression,})$$

therefore the *oblique* compression, when the direction of the disturbing force  $P$  is such that the neutral axis is in the *surface* of the mass, equals twice the *direct* compression; that is, the compression produced by the same force  $P$  acting through the centre of gravity, (see Art. 210.) If  $M p$  be less than  $\frac{1}{3} M B$ , the neutral axis is *without* the surface. In either of these cases the material is evidently *compressed* throughout the entire width of the beam.

It appears, then, that in order that the beam may sustain compression in one portion of its transverse section, and extension in another, by the action of a force in the direction of its length; that force must not be applied at a depth beneath its surface, greater than one-third its whole depth.

214. If the force  $P$ , instead of being applied in the direction of the *length* of the mass, be applied, as in the accompanying figure, in the direction of its *width*, then, supposing the mass to be held at rest by forces applied at its extremities, *also* in the direction of its width, since the forces acting upon it may be resolved into two sets, of which one set, composed of those in the direction of the *width*, is *perpendicular* to the forces of the other,

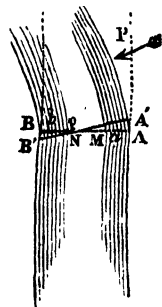



which result from the extension and compression of the material about the plane  $AB$ , and act in the direction of the *length* of the beam, it follows that the resultant of the forces of the first set must equal zero, and also the resultant of the forces of the other set. For taking these resultants, they will manifestly be in directions at right angles to one another, and must, if *both* resultants do not vanish, have a *common* resultant, which will be the resultant of all the forces of the system. That is, *all* the forces of the system will have a resultant of finite magnitude: which they *cannot*, since they are in equilibrium.

215. The parallel forces of compression and extension, acting upon the section  $A'B'$ , have, therefore, a resultant equal to zero. Hence, therefore, it follows that the sum of the forces produced by compression, is equal to the *sum* of the forces produced by extension. (Art. 46.) And thus, by what has been said before,

$$m \times (\text{mass } NAA') = m' \times (\text{mass } NBB')$$

If the modulus of elasticity were the same for compression as for extension; and the mass were symmetrical about a certain plane to which the direction of the force  $P$  was perpendicular, then this plane would be the neutral plane of the mass. Thus, the neutral plane of a rectangular beam would divide it equally, and the neutral plane of a cylinder would be any plane passing through its axis.

216. Since the parts of the material in the neighbourhood of the neutral plane, sustain but an exceeding small portion of the whole pressure, and supply but an exceeding small portion of the forces which produce the equilibrium, their form and dimensions being but little altered; it follows that the strength of the cylinder would not be materially impaired by cutting these parts away. Also, if the mass be required to sustain pressure equally, not in *one direction* only, but in any direction round its surface, then those parts may be cut away which lie about the neutral plane, in every position which that plane is made to take up, as the direction of the pressure changes. Now the parts of the cylinder which thus lie about *every possible* position of its neutral plane are the parts about its axis, through which the neutral plane has been shown always to pass, or *from* which it can, at any rate, only be made to deviate by a small quantity resulting from the inequality of the moduli of compression and extension.

Thus, then, the strength of a solid cylinder to resist a transverse strain is not greatly diminished by cutting away the parts about its axis, or *hollowing* it. And its strength will be greatly

*increased* if the material taken from the interior be accumulated on its exterior surface. Now having to construct a mass capable of sustaining transverse strain *equally* in all directions, it is evident that we must form it into a *cylinder*; and having to construct it (with a given quantity of materials) *of the greatest possible strength*; it follows, from what has been said above, that we must form it into a *hollow* cylinder.

It is *thus* that nature works, when, with the least possible quantity of material she would give the greatest possible strength. The bones of animals are hollow cylinders. In the structure of birds, where it is especially important that very little material should be used, that the weight may be the *least* possible, and where great *strength* is required; the thinness of the substance of the bone is remarkable. The stems of plants are commonly hollow cylinders, varying in thickness from one-sixth to one-tenth of their diameters. Similarly, the feathers of birds are *hollow* cylinders in that part where, acting as the smaller arm of a lever, the feather sustains the effort of those powerful muscles which put the wing in motion. And the lightness of these feathers, as compared with their strength, has passed into a proverb.

The arts have availed themselves of this principle of strength, copying it from nature. Iron columns, destined to support great weights, are cast hollow. And on the same principle, iron beams are made *deep*, in the direction in which they sustain the pressure, and *narrow* in the direction at right angles to this; and they are not unfrequently *pierced* about their neutral surface.

217. In the case of a rectangular section, the masses  $NA A'$  and  $NBB'$  are to one another in the ratio of the squares of  $NA$  and  $NB$ . Now the extent of the compressed and extended surfaces may be readily ascertained by experiment. We have only to support the beam horizontally, by means of props or otherwise, and load it with weights; as it yields to the load, those portions of the section which compress, and those which extend, may readily be distinguished on its surface. Also the masses  $NA A'$  and  $NBB'$  are to one another as the quantities  $m$  and  $m'$ , by the preceding equation. We have thus, therefore, a practical method of ascertaining the ratio of  $m$  to  $m'$ . This ratio is the same with that of the forces of extension and compression at equal distances from the neutral point.

When a piece of timber is broken asunder, the compressed and extended portions of the section are easily distinguished by the appearance of the fibre. Where extension has taken place,

it presents a series of broken and projecting points; where the rupture has been by compression, the section is comparatively smooth. In the immediate neighbourhood of the neutral point there is no apparent change in the structure of the material.

218. The following ingenious method of exhibiting the effects of the compression and extension of the fibres of timber by the action of a transverse strain, was contrived by Duhamel. In the middle of a beam he made an incision with a saw, to three quarters of its depth; and inserted in the cut an exceedingly slender wedge of hard wood. The timber being then supported at its extremities with that face in which the incision had been made *upwards*, it was loaded with weights, and it was found that although thus sawn three quarters through, it was as strong as before.

The following Table contains the values of the quantities  $M$  and  $E$  (see Art. 209), for a variety of different substances arranged alphabetically. Also the pressure which each will bear on a square inch of surface without permanent alteration of structure; and the fraction of its length through which it may be extended.

Substance.	M. the unit is here taken to be one inch.	E.	Weight which each square inch will bear without permanent alteration of struc- ture.	Parts of its whole length through which any portion of the mass will bear to be extended.	Name of the Experimenters.
Ash .....	lbs. 1,640,000	feet. 4,970,000	lbs. 3640	46½	Barlow.
Beech .....	1,345,000	4,600,000	2360	570	Barlow.
Brass, cast .....	8,930,000	2,460,000	6700	1333	Tredgold.
Cast Iron.....	18,400,000	5,750,000	16300	1204	Tredgold.
Elm .....	1,340,000	5,680,000	3240	414	Barlow.
Fir, red or yellow .....	2,016,000	8,330,000	4290	470	Tredgold.
Fir, white.....	1,830,000	8,970,000	3680	504	Tredgold.
Gun metal, cast (copper 8 } parts, tin 1) .....	9,573,000	2,790,000	10000	960	Tredgold.
Iron, malleable .....	24,930,000	7,550,000	17800	1400	Tredgold.
Larch .....	10,074,000	4,415,000	2065	520	Barlow.
Lead, cast .....	720,000	146,000	1500	480	Tredgold.
Mahogany, Honduras .....	1,596,000	6,570,000	3800	420	Tredgold.
Marble, white .....	2,520,000	2,150,000	—	1394	Tredgold.
Mercury .....	4,417,000	750,000	—	—	Cantou.
Oak, good English .....	1,700,000	4,730,000	3960	430	Tredgold.
Pine, American yellow }.....	1,600,000	8,700,000	3900	414	Tredgold.
Slate, Welsh .....	15,800,000	13,240,000	—	1370	Tredgold.
Steel .....	29,000,000	8,530,000	45000	—	Dr. Young.
Slate, Portland .....	1,633,000	1,672,000	—	1789	Tredgold.
Tin, cast .....	4,608,000	1,463,000	2880	1600	Tredgold.
Water .....	326,000	750,000	—	—	{ Calculated by Young from Cantou's Expts.
Whalebone .....	820,000	1,458,000	5600	146	Tredgold.
Zinc.....	13,680,000	4,480,000	5700	2400	Tredgold.

## CHAPTER XVII.

- |  |  |
|--|--|
| <p>219 On the Stability of Masses whose Bases are Plane Surfaces.</p> <p>220 On the Stability where the Bases are Curved Surfaces.</p> | <p>221 When the Surface on which the Base rests is a Curved Surface.</p> <p>222 On Surfaces of Unrest.</p> |
|--|--|

## ON THE STABILITY OF HEAVY BODIES.

219. IF a body be held at rest in any position by the action of certain forces impressed upon it, and by the action of some other force, it be moved out of that position; then it becomes a question whether, when this last force is removed, it will, by the action of the forces before impressed upon it, tend to return towards its first position, or to recede further from it. In the first case its equilibrium is said to be *stable*, in the second *unstable*. The mass  $ABCD$  is in equilibrium in both

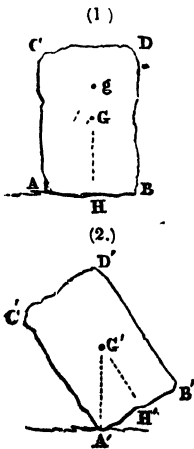

its positions represented in the accompanying diagrams. The vertical from the centre of gravity  $G$ , passing, in the first, through a point  $H$  in the base of the body, and in the other through its angle  $A'$ , and the resultant of the weights of its parts being thus in both cases sustained by the opposite resistance of the surface on which it rests. There is this important difference, however, between the two positions. The first is a position of stable equilibrium; since, if the body be inclined into any position between that and the second position of equilibrium, it will, by the action of its weight, *tend to return*, and if left to itself *will return to it*. But in the second position, if moved either way, it will manifestly *tend to recede* from that position, and, if left to itself, *will recede*

from it, until by this revolution it is brought at length into some stable position.

It is *practically*, perhaps, impossible to *place* a body accurately into the position represented in the second figure. Also when left to itself, not being in that position, it will not *return*; but *recede* continually from it. Since, then, the body *cannot* be artificially *placed* in a position of unstable equilibrium, when placed out of that position will not, of its own accord, *return* to it, it is impossible that it should ever be in such a position so

as to *rest* in it. Thus if there were not certain of its positions in which its equilibrium is stable, it would be perpetually in a state of *unrest*.

220. If  $\Delta C$  be drawn perpendicular to the plane on which the body rests, the angle  $G \Delta C$  will be that through which it is made to revolve between its first and second positions; or it will be its *inclination* in its second position. Now the angle  $G \Delta C$  is equal to the angle  $\Delta G H$ . To be brought from its first into its second position of equilibrium, the body must, therefore, be inclined through an angle equal to that made by the line joining its centre of gravity with the angle about which it is made to turn, and the *vertical* through its centre of gravity. Now, the *higher* the centre of gravity of the body is, the *less* is this angle. Thus, if the centre of gravity had been at  $g$  instead of  $G$ , the angle would have been  $\Delta g H$  instead of  $\Delta G H$ , and the first of these is evidently *less* than the other. Hence, therefore, the higher the centre of gravity of a body is above its base, the less is the angle through which it will bear to be inclined without passing into a position of unstable equilibrium.

body will remain at rest in its second position; if it do not, it will revolve [from that position in the direction *towards* which the centre of gravity lies. That is, it will revolve *towards* its first position, or *from* it, as the centre of gravity lies in respect to the point of support *towards* or *from* that position. In the first case the equilibrium is stable, in the other unstable.

Now it is evident that  $G$  lies, in respect to  $A'$ , *towards* the first position of the body, or *from* it, according as  $AG$  is less or greater than  $AO$ ; this condition determines, therefore, the character of the equilibrium. If  $AG$  be less than  $AO$  it is stable; if greater, it is unstable. If the mass rest, as in the figure, upon a horizontal plane, the vertical through the point of support is perpendicular to the surface of the body at that point.

222. Suppose that portion of the surface of the body which rests upon the plane, to be part of a sphere. Then since the lines  $AO$  and  $A'O$  are perpendicular to the surface of the sphere in the points  $A$  and  $A'$ ; the point  $O$ , where they meet, is its centre. Hence, therefore, it follows, that the equilibrium of such a mass is stable or unstable, according as its centre of gravity is *below* or *above* the centre of the sphere, of which its base is a segment. If the centre of gravity of the mass, *coincide* with the centre of this sphere, the equilibrium will be neither stable nor unstable, and is said to be *indifferent*. Into whatever position it is moved, the vertical through its centre of gravity will in this case pass through its point of support; it will, therefore, rest in that position, and will have no tendency either to approach again to, or recede further from, the position which it previously occupied. If the body have not only a spherical base, but be a *complete* sphere; its centre of gravity will manifestly coincide with its geometrical centre; and, therefore, in whatever position it is placed, it will rest *indifferently* in that position. But if the upper portion be a cylinder, and the lower a sphere, then, provided the former be of such a height, as to raise the centre of gravity of the whole above the centre of the sphere, of which the lower portion is a part, the equilibrium will be unstable, and the body will not be found to rest every where upon its spherical base. The cylinder might be taken of such a height, as to make the centre of gravity of the whole figure *coincide* with the centre of the sphere; the equilibrium would then be *indifferent*: or it might be taken of such a height, as to make the centre of gravity fall *below* the centre of the sphere; it would then be *stable*. If the

base of the body be a *hemisphere*, and the upper portion a right cone, whose height is *equal* to a radius of the hemisphere, multiplied by the square root of three, it will rest on any point of its hemispherical base on which it is placed.

223. In order to determine the character of the equilibrium at any point in its surface, on which a body will rest, we have only to displace it the least conceivable distance from that position, for when thus displaced, however slightly, if its equilibrium be unstable, it will revolve continually further from its first position; if it be stable, it will revolve towards it. Thus, then, all that we have said above, with regard to the character of the equilibrium at  $A$  is true, however near  $A'$  be taken to it. Now, whatever the form of that part of its surface on which the body rests may be; a sphere may be taken of such dimensions, and in such a position, as accurately to coincide with that surface, immediately *about* any given point in it. Thus a sphere may be taken accurately to coincide with the surface immediately about the point  $A$ . This sphere is called the sphere of curvature, and its radius, the radius of curvature; the length of the radius of curvature may, in all cases, be expressed by certain algebraical formulæ. Now, if  $A'$  be immediately adjacent to  $A$ , it lies on the surface of the sphere of curvature, at that point; and  $Ao$  and  $A'o$  are perpendicular to the surface of this sphere, therefore  $o$  is its centre. The general proposition may then be enunciated as follows: "The equilibrium at any point on which the body will rest, is stable or unstable, according as the centre of gravity is *below* or *above* the centre of the sphere of curvature at that point."

224. If the body, instead of resting upon a horizontal plane, rest upon a surface in any way inclined, or on another curved surface, as in the accompanying figure, the vertical  $A'o$  through the point of support in its second position, will no longer be perpendicular to its surface at that point, and  $o$  will cease to be the centre of the sphere of curvature at  $A$ . As before, however, if  $G$  lie nearer

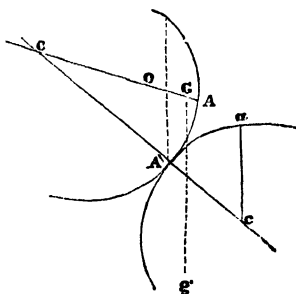

to  $A$  than  $o$ , the body, when left to itself, will roll *back into* its first position; if it lie further off, it will roll still further *out of* its first position. Thus, if the surface on which it rests be



convex, as in the figure, it may be made to roll of its own weight *upwards*, or contrary to the direction in which its weight acts. Since the equilibrium is stable or unstable, according as  $\Lambda G$  is less or greater than  $\Lambda O$ , it becomes of importance to determine the magnitude of  $\Lambda O$ . Suppose  $\Lambda'$  to be exceedingly near to  $\Lambda$ , and draw  $c \Lambda' c$  perpendicular to the surface of either body in  $\Lambda' : c$  and  $c$  will be the centres of the spheres of curvature of the two surfaces at  $\Lambda$  and  $a$ . Now since the body is exceedingly little deflected from its position of equilibrium,  $\Lambda$  and  $a$  very nearly coincide, and the figure formed by the lines  $\Lambda c$ ,  $a c$ , and  $c c$ , may be considered a *complete* triangle. This being the case, we have, by the known property of similar triangles,  $c c : c \Lambda' : : c \Lambda : \Lambda O$ .

Now  $c c$  is equal to the sum of the radii of curvature at  $\Lambda$  and  $a$ ; for since  $c$  and  $c'$  are the centres of the spheres of curvature at  $\Lambda$  and  $a$ , and  $\Lambda'$  being very near  $\Lambda$  and  $a$  is in both these spheres, it follows, that  $c \Lambda'$  and  $c' \Lambda'$  are *radii* of the spheres. Also  $c \Lambda'$  is the radius of curvature at  $a$ , and  $c \Lambda$  that at  $\Lambda$ . Thus all the terms in the above proportion are known, except the last; this may, therefore, be found by that simple arithmetical operation called the Rule of Three. If the proportion be thrown into an equation and reduced; the following simple relation will be found to exist between  $\Lambda O$  and the radii of curvature at  $\Lambda$  and  $a$ . The latter being represented by  $R$  and  $r$ ,

$$\Lambda O \quad R \quad r$$

225. A portion of the surface of a body may be so contrived, that the vertical through its centre of gravity, shall not, in any position in which it can be placed on a horizontal plane, pass through its point of support. If a surface could be thus formed, which would return *into itself*, so as completely to envelop or contain a solid mass, or any portion of it; then such a mass, when placed on a horizontal plane, would be in a state of *perpetual unrest*: it would roll on for ever, and the problem of perpetual motion would be solved. There exists, however, no such surface. A surface possessing the properties of which we have spoken, is essentially a *spiral* surface; it does not return into itself, and cannot be made *completely* to contain any solid mass, or any portion of it. Nevertheless, such a surface may be made to form *part* of the surface of a solid; and as long as it is supported upon that part of its surface, the solid  
... continue to revolve.

226. A surface may be generated, answering these conditions by unwinding a sheet from a cylinder. Keeping the part unwound continually *stretched*, its edge will describe in space a spiral surface, called an *involute*. The accompanying figure represents such an involute,  $\Delta B A$  being the cylinder called the generating cylinder, from which the surface  $B p P$  has been unwound. The characteristic property of the surface  $B p P$  is this, that any line  $p a$  drawn perpendicular to any point  $p$  in it, if produced far enough, necessarily *touches* the surface of the cylinder. The vertical through the point of support  $P$ , therefore, *touches* the surface of the cylinder, since it is perpendicular to the surface of the spiral at that point, being perpendicular to the horizontal plane which is a tangent to it *there*.

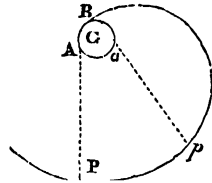

Now, since the vertical  $PA$  *touches* the surface of the cylinder, it cannot, when produced, pass through any point *within* it. If, therefore, the mass be so loaded, that its centre of gravity,  $G$ , may lie *within* the generating cylinder, then the vertical through the point of support, can never pass through its centre of gravity; and conversely, the vertical through its centre of gravity, can never pass through its point of support; the mass, therefore, can never rest upon its spiral surface. It will, in fact, roll on, until one end of the spiral, coming in contact with the plane, supplies a *second* point of support, and stops its further revolution.

## CHAPTER XVIII.

### ON THE PRINCIPLE OF VIRTUAL VELOCITIES.

227. IF any number of forces applied to the different points of a system be in equilibrium; and these points admit of *displacement*, the circumstances of their mutual relation and dependance remaining unaltered; and further, if the nature of the system, and the forces applied to it, be such, that the points of application, being thus altered according to certain conditions, the equilibrium *remains*; then there will exist the following remarkable relation between the forces and the distances through which their points of application have been made to move. If from either extremity  $P'$  of the line  $PP'$ , representing

the *exceeding small* displacement of any point of application  $P$ , a perpendicular  $P'm$  be drawn upon the direction  $P$  of the force before its displacement; and the line  $Pm$  intercepted between the foot of the perpendicular  $m$  and the point  $P$ , be called the *virtual velocity* of the force  $P$ ; then each force of the system being multiplied by its *virtual velocity*, similarly taken; the sum of these products in respect to the points of application which are made by the displacement of the system, to move *towards* the direction of the forces impressed upon them, shall be equal to the sum of those taken in respect to those points which are made to move *from* that direction. This very important principle is called that of virtual velocities.

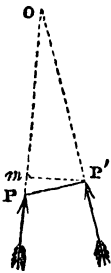

228. It may be proved as follows. Each point of application of a force may be supposed to be held at rest by the action of two equal and opposite forces, one being the force  $P$  actually applied to that point, and the other  $p$ , the resultant of the resistances or tensions upon it arising out of its connexion with the other parts of the system. Now, let us suppose these resistances and tensions to be all removed, and their place supplied by the intervention of a system of pulleys in which the same string is made to pass over all the pulleys. The most convenient, probably, that can be conceived, is a system similar to White's pulley (Art. 158); the separate pulleys must not, however, be all fixed in the same block, but each separately moveable about a common axle. Let each system have as many strings as there are units in the force which it is intended to replace, then the tension on each string will equal one unit. Let the *same* string pass over all the different systems; then if one end of the string be fixed to the centre of the first moveable block, and the other hang freely over the extreme pulley of the last fixed block; a weight equal to one unit of force, attached to this last extremity of the string, will keep the whole at rest under the circumstances supposed. Each system of pulleys supplying a force equal to the resistance or tension which it is made to replace.

The arrangement of pulleys which has been described, is represented in the accompanying figure:  $P_1, P_2, P_3, P_4$ , are the points of application of the forces of the system, and the resistances or tensions upon those points are supposed to be replaced by the systems of pulleys  $A_1 B_1, A_2 B_2, A_3 B_3, A_4 B_4$ , of which  $A_1, A_2, A_3, A_4$ , are the *fixed*, and  $B_1, B_2, B_3, B_4$ , the *moveable* blocks. All

these are of course supposed to be without weight; and each contains as many *separate* pulleys as there are units in the corresponding force. A string is attached to the centre of the first block  $B_1$ , and passed as many times round the pulleys of that

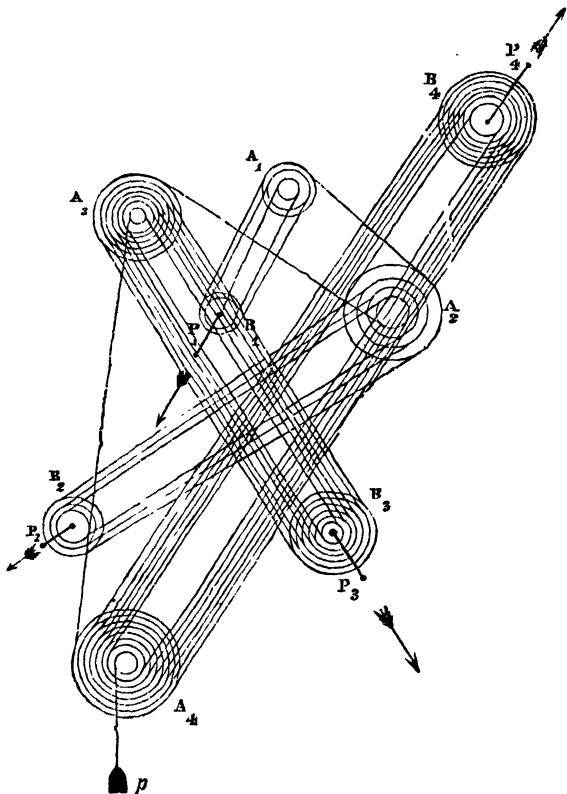

block, and the block  $A_1$ , as there are units in the force  $P_1$ . It then passes to the block  $A_2$ , and as many times round the pulleys of that block and the block  $B_2$ , as there are units in the force  $P_2$ : and from thence, to the system  $A_3 B_3$ , supplying there again as many strings as there are units in the force  $P_3$ . To the extremity of the string which hangs over the last pulley of the block  $A_4$  a weight  $p$  is attached equal to one unit. Now since we suppose no rigidity in the cord, and no friction on the axes of the pulleys, it is evident (Art. 142) that the tension upon the cord is every where *the same*, and, therefore, every where equal

to one unit. Also the tension upon the first point  $P_1$  is equal to the tension upon any string of the system  $A_1 B_1$  multiplied by the number of strings. And the tension upon each string has been shown to be one unit, therefore the whole tension upon the point  $P_1$  is equal to as many units as there are strings; but there are (by hypothesis) as many strings as units in the force acting at  $P_1$ ; there are, therefore, as many units in the *tension* at  $P_1$  as in the force applied there; and the tension is in a direction *opposite* to the force: the point  $P_1$  is, therefore, in equilibrium; and the action of the system of pulleys  $A_1 B_1$  *correctly* replaces the resistances and tensions which were supplied by the connexion and reaction of the different parts of the system at the point to which the force  $P_1$  is applied. The same may be proved of the other points of application  $P_2 P_3 P_4$ . The system of pulleys we have supposed, supplies, therefore, at all the points of application, forces exactly equivalent to the resistances and tensions before sustained at those points.

Now let us suppose the points  $P_1 P_2 P_3 P_4$ , &c., to move through any small distance, and in any direction, subject only to this condition, that in the new position which they take up, and in every intervening position, they may be in equilibrium, and the resistances or tensions upon their several points of application remain the same. Since the tensions upon the points  $P_1 P_2$ , &c., remain the same throughout this motion, the tensions upon the strings of the systems applied to these points remain the same, and the tension upon every part of the length of the string which goes round them all remains the same. Since, then, the tensions upon that part of the string which sustains  $p$  does not alter, it follows that  $p$  is always balanced by it, and does not *move*. It follows, also, that the string *thrown off* by those of the systems  $A_1 B_1$ ,  $A_2 B_2$ , &c., in which the blocks are made, by the motion of the points  $P_1 P_2$ , &c., to *approach* one another, is *taken up* by those systems in which the blocks recede from one another; for otherwise some portion of the string would be thrown off the last system, and  $p$  would move. Thus the sum of the portions of string *thrown off* by certain of the systems is equal to the sum of those *taken up* by the remainder.

Now the *approach* or recession of the blocks of any system, by reason of the motion of the corresponding point of application, is in fact the *virtual velocity* of that point. Referring to the figure (page 168), we shall perceive that the distance of the point  $P$  from  $o$ , which may represent the centre of the *fixed* block  $A_1$ , is diminished, when the distance  $PP_1$  through which it moves is small, by a quantity equal to  $Pm$ , since the angle

$m o p'$  being small,  $o m$  may be considered equal to  $o p'$ . Also this equality will obtain accurately for any distance through which the points of application may be moved, provided we suppose the forces applied to them always remain *parallel* to their first direction. In which case the fixed blocks  $A_1, A_2, A_3$  must be situated at *infinite* distances from the moveable blocks; an hypothesis which will not, in the least, affect the demonstration, the length of the string being entirely arbitrary. *Under these circumstances* the *virtual velocities* may, therefore, be supposed to have reference to *any* motions of the points of application however *great* those motions may be.

Since, then, the quantities by which the blocks approach or recede from one another, are the *virtual velocities* of the forces which the strings passing round those blocks sustain; and since the string thrown off by these blocks is equal to as many times this change in the distance of the blocks as there are strings passing from block to block; also, since this number of strings equals the number of units in the corresponding force; it follows, that, representing this number in units of the force applied at  $P_1$  by  $P_1$ , and the virtual velocity of that force by  $n_1$ , the quantity of string thrown off by the first system is  $P_1 n_1$ . Similarly, that thrown off by the second is  $P_2 n_2$ ;  $P_2$  representing the number of units in the force applied at  $P_2$ , and  $n_2$  its virtual velocity; and so of the rest. Also, the sum of the quantities of string thrown off by the blocks which approach one another, equals the sum of those thrown off by the blocks which recede from one another; therefore, the former being understood to be taken with a negative sign, we have  $P_1 n_1 + P_2 n_2 + P_3 n_3 + \dots = 0$ . This perhaps may be better understood when it has been applied to a few examples.

229. Let us take the case of the wheel and axle (see Art. 114). It is apparent that if the power and weight be in equilibrium in one position of either, that equilibrium will also exist in any other position. Also, that their directions preserve always their parallelism. The system, therefore, belongs to that class in respect to which the principle of virtual velocities has been proved to obtain, whatever be the extent of the motion communicated to it. Also, the virtual velocity of either is, in this case, the space actually described by it, since either, in its second position, occupies a point in the line in which the force impressed upon it acted, in its first position\*. Hence, there-

\* This will readily be seen by reference to the fig. page 168, where  $P$  must be supposed to move in the line  $P o$ , the point  $p'$  being in the line, and  $P p'$  coinciding with  $P m$ .

fore, supposing the power  $P_1$  to give motion to the weight  $P_2$ , calling  $n_1$  and  $n_2$  the spaces described by these respectively, and writing the latter *negatively*, since it is described in a direction opposite to that in which the force to which it corresponds acts, we have  $P_1 n_1 - P_2 n_2 = 0 \therefore P_1 n_1 = P_2 n_2$ . Hence it appears that the power multiplied by the space which it describes is equal to the weight multiplied by the space which *it* describes. And as many times as the power is *less* than the weight, so many times is the space through which it moves *greater*\*.

The spaces  $n_1$ ,  $n_2$  are manifestly equal to those portions of the circumferences of the two circles *off* and *on* which the string is wound; now these being opposite to equal angles at the centre (each equal to the angle through which the axle has been turned), they are to one another as their radii. Thus  $n_1$  and  $n_2$  are to one another as the radii of the wheel and axle respectively, and we have as before (Art. 114),

$$P_1 \times (\text{radius of wheel}) = P_2 \times (\text{radius of axle}).$$

230. Let us take the inclined plane for our second example, and suppose the force  $N$  (see fig. Art. 80) to act *parallel* to the plane, and also the consideration of friction to be omitted. Suppose the mass  $M$  to be made to descend the *whole length* of the plane. Being in equilibrium in one position, it would manifestly be in equilibrium if allowed to rest in any other position; the forces preserving always their parallelism. The case comes, therefore, under that for which the principle of virtual velocities has been demonstrated, whatever be the extent of motion. Also, the *virtual velocity* of the weight  $M$  is, in this case, the *height* of the plane; and the *virtual velocity* of  $N$  is the length of the plane,

$$\therefore N \times (\text{length of plane}) = M \times (\text{height of plane}),$$

which agrees with what has been before proved (Art. 85).

231. As a third example, let us take the case of the single moveable pulley (see fig. page 116). It is evident that the system is of that class for which the principle of virtual velocities has been proved, and that the virtual velocities of  $P$  and  $R$  are the spaces they actually describe; calling these, therefore,  $n_1$  and  $n_2$ , we have

Also  $n_1 = 2 n_2$ , for each of the two parts of the string which sustain  $R$ , are shortened by a distance  $n_2$ ; therefore the whole of the string sustaining the moveable pulley is shortened by *twice*

\* This principle is well known to workmen; they enunciate it, however, thus: "What is gained in power, is lost in velocity."

that distance. The power moves, therefore, through twice that distance; or,

$$n_1 = 2 n_2 \quad \therefore P 2 n_2 - R n_1 = 0 \quad \therefore 2 P = R.$$

232. Similarly it may be shown, in the first system of pulleys, (Art. 151), that each moveable pulley in succession, counting from the last, moves through twice the distance of the preceding pulley, and that the power  $P$  moves through twice the distance of the *first* moveable pulley, so that calling  $n_2$  the space described by the last moveable pulley, and, therefore, by the force  $R$ , the spaces described by the others in order, are  $2 n_2$ ,  $4 n_2$ ,  $8 n_2$ , &c., and if there be four such moveable pulleys, the space described by the power equals  $16 n_2$ , or  $n_1 = 16 n_2$ . Now, as before, by the principle of virtual velocities,

$$P n_1 - R n_2 = 0 \quad \therefore P 16 n_2 - R n_2 = 0 \quad \therefore 16 P = R;$$

a result which is the same as that we have before obtained. A similar method of reasoning may be applied to all the systems of pulleys.

The principle of virtual velocities readily applies itself to the solution of every question in statics, into the consideration of which the resistance arising from friction does not enter. In fact, the principle of the *equality of moments*, and that of the *parallelogram of forces*, on which the whole science depends, may be readily deduced from it.

233. We have proved this principle of virtual velocities on the supposition that the forces impressed upon the system remain in equilibrium, whatever be the position which their points of application are made to take up. And on this hypothesis we have shown it to obtain, whatever may be the distances through which these points are made to move, provided only the forces impressed upon these, retain always their parallelism. The same principle, however, obtains *generally*, whatever be the circumstances of the equilibrium, and the directions of the forces, or the motions of the points of their application; provided, only, those motions be exceedingly small, so that the resistances and tensions of the parts of the system may not be thereby sensibly changed. This last hypothesis being made, the proof is precisely the same with that we have already given. In fact, the absence of all change in the tensions or resistances of the parts of the system is that supposition on which the whole demonstration rests, and it matters not under what circumstances it is made.

When virtual velocities are spoken of, they are usually understood to have reference to these indefinitely *small* motions of the



parts of a system. The principle of virtual velocities may, therefore, be stated under its most general form as follows. "If any number of forces be, under any circumstances, in equilibrium, and to any or all of their several points of application, there be communicated indefinitely small motions in any direction; then the several virtual velocities of these points, multiplied by their corresponding forces, and added together, shall give a result zero; those which are moved *towards* the directions of their forces being taken with a *negative*, and the remainder with a *positive*, sign." It is of the highest importance that the practical man should obtain a *clear* notion of the application of this principle, in its most *general* form. The ideas which workmen *usually* have of it are erroneous.

## CHAPTER XIX.

- |   |   |
|---|---|
| 234 Difficulty of determining mechanically the amount of any Statical Resistance. | 236. Where there are Two Resisting Points.  |
| 235 Theory of Resistances where there is only One Resisting Point.                | 237 Where there are three Resisting Points. |
|   | 239 Principle of Least Resistance.          |

## ON THE THEORY OF RESISTANCES IN STATICS.

234. A CERTAIN number of the forces which hold a body at rest *may be*, and in the great majority of cases *actually are*, supplied by the *resistances* of certain fixed points, or surfaces. It appears to be nearly impossible to contrive any method, generally applicable to a measurement of the amounts or magnitudes of these resistances. The mechanical contrivances commonly used to estimate the amount of pressure, are applicable only to the state immediately bordering upon motion. Now, when any of the forces which hold a body at rest are resistances, these, any or all of them, admit of being infinitely varied, without communicating motion to it.

Thus, to take a familiar example, we may vary the weights placed upon a table sustained by four legs, infinitely, without producing motion; we may even remove the portion of the floor on which one of the legs is supported, and place that leg in one of the scale-pans of a balance, and although the weight upon the table remain the same, we shall find that we may vary the weight placed in the opposite scale of the balance infinitely (within certain limits), without communicating motion to the beam. Now, there was clearly a certain resistance, and no other, sus-

tained by the leg of the table, before the portion of the floor on which it rested was removed ; but which of the pressures shown by the balance, was *that* pressure, it is altogether impossible to determine. A similar difficulty presents itself in the use of weighing-machines made with springs ; these estimate pressures by the greater or less degree of yielding in the points at which they are applied ; thus, one of the feet of the table being attached to such an instrument, would sink until the pressure sustained by it was equipoised by the elasticity of the spring. But this liability to yield would take the pressure completely out of the class of the pressures supposed, which are those supplied by *fixed* points and *fixed* surfaces.

235. Not only is there, however, this difficulty in measuring the amounts of statical resistances *mechanically*. The *theory* of statical resistances presents almost equal difficulties. If there be any number of forces in equilibrium, amongst which there enters *one* resistance only ; we could determine the amount of that one ; for, knowing all the other forces of the system, we can find the magnitude and direction of their resultant ; and we know that this resultant must pass through the resisting point : that it must be *opposite* to the resistance in direction, and equal to it in magnitude. The amount and direction of the single resistance thus becomes known to us.

If there be two resistances in the system, and we know their points of application, and the direction of one of them ; we can also find the *direction* of the other, and the magnitudes of both. For let us take the resultant of those forces of the system which are *not* resistances, and suppose these forces to be *replaced* by it. The whole will then be held at rest by three forces, the resultant and two resistances ; the directions of these are, therefore, in the same plane, and meet, when produced, in the same point. Now the direction of one of the resistances is known, let it be produced to meet the resultant ; then a line drawn from their point of intersection, to the point of application of the other resistance, will be in the direction of that resistance. And the *directions* of both resistances being known, also the magnitude and direction of their resultant being known, the *magnitude* of each resistance may be ascertained by the principle of the parallelogram of forces.

If the points of resistance be *fixed* points, capable of supplying resistance in every possible direction, it will be shown hereafter that the direction of the resistances is necessarily parallel to that of the resultant force. If the points of resistance be points capable of motion upon a given surface, which surface

will supply resistance only in certain directions ; then the directions of the resistances are those which approach the nearest possible to parallelism.

236. Let us suppose the points of resistance  $P_1$  and  $P_2$  to be fixed, and let  $R$  be the resultant of any system of forces in equilibrium, of which the resistances of these points form a part ; then are the resistances at  $P_1$  and  $P_2$  parallel to  $R$ . Draw from either of the points  $P_1$  a line  $P_1 M N$ , perpendicular to the direction of that force and intersecting the direction of that force and  $P_2$  in  $M$  and  $N$ . Then, since the moments of the forces of the system about any point, as  $P_1$ , are equal, we have

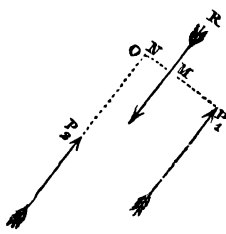

$$P_2 \times P_1 N = R \times P_1 M.$$

Now, since the directions of  $P_2$  and  $R$  are known, the lines  $P_1 N$  and  $P_1 M$  are known, also  $R$  is known, therefore  $P_2$  is known from the above equation ; also  $P_1 + P_2 = R$ . Therefore,  $P$  may be found.

As a practical application of what has been stated above, let us suppose a weight  $w$  to be supported upon two fixed points  $P_1$  and  $P_2$  by the intervention of a rod  $P_1 P_2$ , supposed without weight.

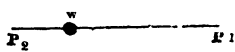

By the principle of the equality of moments,

$$P_1 \times P_1 P_2 = w \times P_2 w.$$

Thus  $P_1$  and  $P_2$  are known.

237. If instead of two there be three points of resistance, there is one and only one case, in which the amounts of the resistances on these points can be ascertained by any of the rules of statics which have hitherto been laid down. The case is that in which the resistances are those of points which are fixed in both surfaces, and whose directions are, therefore, parallel to that of the resultant of the other forces impressed upon the system.

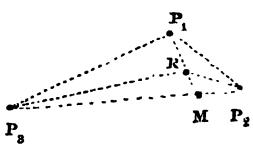

Let us suppose a plane to be drawn perpendicular to the direction of the resultant  $R$ , and intersecting the directions of the three resistances of the system in the points  $P_1$ ,  $P_2$ ,  $P_3$ , which

points we will, for the present, suppose not to be in the same right line. Let the points  $P_1$ ,  $P_2$ ,  $P_3$  be joined by lines forming

the triangle  $P_1 P_2 P_3$ . Also let lines be drawn from the same points to  $R$ , dividing the whole triangle  $P_1 P_2 P_3$  into three elementary triangles  $R P_1 P_2$ ,  $R P_2 P_3$ , and  $R P_1 P_3$ .

Then the magnitude of each resistance will be to the resultant of the whole, as the elementary triangle on the side opposite to that resistance is to the whole triangle\*. Thus the resistance at  $P_1$  is to  $R$  as the triangle  $R P_2 P_3$  is to the triangle  $P_1 P_2 P_3$ .

This may be easily proved. Let the forces  $P_1$  and  $R$  be supposed to be replaced by their resultant, and also the forces  $P_2$  and  $P_3$  by their resultant. These resultants are necessarily equal and opposite. (Art. 6.) Now, the direction of the former resultant is through some point in the line  $P_1 R$  produced, and the direction of the latter, through some point in the line  $P_2 P_3$ . Both resultants pass, therefore, through the point of intersection  $M$  of these lines.

Since, then, the resultant of  $P_1$  and  $R$  passes through  $M$ .

$$\begin{aligned} P_1 \times M P_1 &= R \times M R \\ \therefore \frac{P_1}{R} &= \frac{M R}{M P_1}; \\ \therefore P_1 &= \frac{\text{triangle } P_2 R P_3}{\text{triangle } P_2 P_1 P_3}. \end{aligned}$$

A similar demonstration applies to the other resistances.

If  $R$  be the centre of gravity of the triangle  $P_1 P_2 P_3$ ,  $M R$  will be equal to one-third of  $M P_1$ ,  $\therefore P_1 = \frac{1}{3}R$ . Similarly each of the other resistances will equal one-third of  $R$ ; these resistances are, therefore, all equal to one another. Thus a triangular table of uniform thickness, supported by legs at its corners, will press with equal force on all of these, whatever be the shape of the triangle; since the resultant of the weights of the parts of the triangle, which are the only forces impressed on it, passes through its centre of gravity. Also, if a weight be placed upon the table over its centre of gravity, the pressure of that weight will be equally divided between the legs.

238. A given weight  $R$  being thus always placed upon the centre of gravity of the triangle, let us suppose the side  $P_1 P_2$  to revolve about the point  $P_2$ , until it is made to coincide with  $P_2 P_3$ . The centre of gravity  $R$  will throughout this variation be

\* This very elegant property of the resistances of three points, was first discovered by Euler, and given by him in the commencement of a paper entitled *De pressione ponderis in planum cui incumbit*, in the *Memoirs of the Academy of Sciences at St. Petersburgh, Novi Commentarii*, tom. 18, in which the question of resistance is discussed at great length.

found by joining the point  $P_1$ , with the bisection  $M$  of the side  $P_2 P_3$ , and taking  $MR$  equal to one-third of  $MP_1$ , also the pressure of  $R$  will, throughout, be *equally* divided between the points  $P_1$ ,  $P_2$ , and  $P_3$ ; this *equal division* will, therefore, continue when  $P_2 P_1$  takes up its *final* position coincident with  $P_2 P_3$ . In this

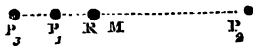

*ultimate* position, therefore of  $P_2 P_1$ , if  $MR$  equal one-third of  $MP_1$ ,  $M$  being the bisection of  $P_2 P_3$ , the pressure of any force applied at  $R$  will divide itself *equally* between the points  $P_1 P_2 P_3$ . It is easily shown, that when the point  $R$  is taken according to the above conditions,  $P_2 R = \frac{1}{3} (P_1 P_2 + P_2 P_3)$ .

239. When the number of points of resistance exceeds three, the problem does not admit of solution by any of the principles hitherto laid down, and recourse must be had to another principle, called the principle of least resistance\*. That principle may be stated as follows. If there be a system of forces in equilibrium, among which are a given number of resistances, then is each of these a minimum, subject to the conditions imposed by the equilibrium of the whole.

This principle is easily proved; although the *application of it* presents considerable analytical difficulties. Let us suppose the forces of the system which *are not* resistances, to be represented by the letter  $A$ , and the resistances by  $B$ ; also let *any other* system of forces which may be made to replace the forces  $B$ , and sustain  $A$ , be represented by  $C$ . Suppose the system  $B$  to be replaced by  $C$ ; then it is apparent, that each force of the system  $C$  is equal to the pressure propagated to its point of application, by the forces of the system  $A$ ; or, it is equal to that pressure, *together with* the pressure so propagated to it by the *other forces* of the system  $C$ . In the former case, it is *identical* with one of the resistances of the system  $B$ ; in the latter case, it is *greater* than it. Hence, therefore, it appears, that each force of the system  $B$  is a *minimum*, subject to the conditions imposed by the equilibrium of the whole.

All the resistances of any system of forces being subject to this condition, the magnitude and direction of each may be determined in terms of the other forces which compose it, by the method of the maxima and minima of any number of variables.

240. From this determination it results that when the

\* The principle of least resistance was first published by the author of this work, in the *Phil. Mag.* for October, 1833.

resistances are parallel, there is a *certain axis*, about which their moments are *all equal*. When they are all in a straight line, this axis resolves itself into a *point*. The condition that any number of parallel resistances in the same right line have their moments about a certain point equal, leads at once to a determination of the position of that point, and to a comparison of the amounts of the several resistances of the system. If these resistances be equal, the point about which their moments are equal, will be found to pass to an infinite distance\*.

241. It manifestly follows, that since these resistances are the *least* possible so as to sustain the resultant of the other forces impressed upon the system, they are as nearly as possible in directions parallel to the direction of that resultant. And, therefore, that if each resisting point be capable of supplying resistance in any direction, they are all accurately parallel to that direction. And if not, that they are inclined at the least possible angles to it. Thus in the wedge (Art. 87), since the force impressed upon the back is sustained by the resistances on the sides, these last have their directions inclined at the least possible angles to the former, and are, therefore, in the limiting directions of the resistances of the surfaces; as is there shown on other principles. (See the Appendix.)

\* This is found to be the case where a given force is sustained by *three* equal resistances in the same straight line, under the circumstances stated in a preceding article.



# HYDROSTATICS ;

OR,

## THE SCIENCE

OF

## THE EQUILIBRIUM OF FLUID BODIES.

### CHAPTER I.

242 Definition of a Fluid.

244 Equal Distribution of Fluid Pressure.

246 Hydrostatic Press.

248 The Pressure of a Fluid upon a Solid is perpendicular to its Surface.

242. OF all substances, a fluid is that with whose properties, as distinguished from a solid, we are probably most familiar, yet it is exceedingly difficult to define those properties. Fluids are usually said to be those bodies whose parts may be made to move among one another, or be separated from one another, by any assignable force, however small. Nature, however, presents us with no fluid answering to this description. Were there no *resistance* opposed to the motion of the particles of fluids among one another, having been once put in motion, they would never return to a state of rest; and the state of a body whose particles might be separated without any effort, would approach more nearly to the state of an impalpable powder, than to that of a fluid.

243. The distinctive character of a fluid appears to be its power of propagating pressure applied to it, not in that direction only in which it is *applied*, as is the case with solids; or in directions limited within a certain angle, as in the case with bodies composed of detached particles, sand for instance; but in every possible direction. To *this* may be traced all those other properties which enter into our notion of a fluid body, as distinguished from a solid.



## DEFINITION OF A FLUID.

Let there be taken a vessel  $AB$ , whose sides are perfectly rigid, and let it accurately enclose a fluid body of any conceiv-

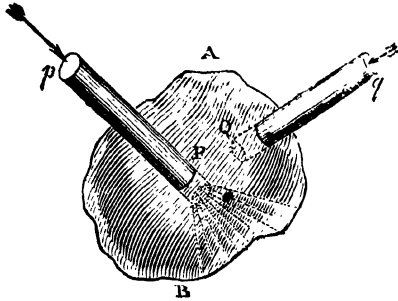

able form. Suppose two solid prismatic masses, called pistons,  $p$   $p$  and  $q$   $q$ , to be inserted to any depth in it through apertures in its sides, to which they are accurately fitted, and in which they move with perfect freedom; also let such forces be applied to these as will *just* keep

them in their places. An equilibrium being thus established, let any other force  $F$  be applied to either piston; it will be found that *wherever the other piston is situated*, an additional force will instantly become necessary to keep that piston at rest. The pressure from the first piston is, therefore, instantaneously propagated to the second; and this being the case, *wherever the second piston is situated*, it follows, that pressure applied to one part of a fluid, is propagated in every possible direction, and to every other part in it.

If, instead of a fluid, the vessel had contained a mass of sand or earth, the piston  $q$  would be found to be affected by a force applied to  $p$ , only so long as it was situated within a space enclosed by lines drawn at a certain angle from  $p$ , and represented in the figure by the dotted radiating lines. Bodies of this kind, of which there is a vast variety, are sometimes called imperfect fluids.

244. From the property that pressure applied to a fluid is propagated *in every direction*, may be deduced this other, "*that it is propagated EQUALLY in every direction.*" This is usually cited as the *principle of the equal distribution of fluid pressure.*

What is meant by it is this,—that a pressure applied to any surface or area, situated in one portion of a fluid, generates a precisely similar and equal pressure upon any equal and similar surface or area, situated in any other portion of it; thus distributing itself equally and similarly throughout the whole fluid mass. Thus, if there be two portions of the sides of the vessel spoken of above, which are of precisely the same form and dimensions, and any pressure be applied to one of them, precisely the same pressure will be produced upon the other. Or

if a solid piston, whose extremity is of any given form, be thrust to any depth into the fluid, so as to produce a given pressure upon a surface any where within it, of the same form and dimensions with the extremity of the piston; then a similar and equal pressure will thus be produced upon an equal and similar surface, situated any where in the sides of the vessel\*. It is clear that the principle stated above, will follow, provided we can show that pressure applied to a *plane* surface any where situated in the fluid, is propagated to any equal and similar *plane* situated elsewhere; for every surface may be considered to be made up of indefinitely *small planes*, and force applied to this surface, as distributed over these planes; now, if the force thus applied to each plane in one surface, be accurately propagated to each equal and corresponding plane in the other, it follows, that the whole pressure of the one *surface* is accurately propagated to the other.

Let us suppose, then, in the preceding figure, the pistons  $p$  and  $q$  to be terminated by *plane* surfaces, and let any forces  $p_1$  and  $p_2$  be applied to these pistons, such as will be in equilibrium with one another. This being the case, let a slight *additional* pressure be for an instant communicated to one of them,  $p$ , so as just to disturb the equilibrium; that additional pressure will be propagated to the other piston; and since both were accurately in equilibrium before, both will now *move*. Let their motions be represented by  $n_1$  and  $n_2$ ; then, by the principle of virtual velocities†,  $p_1 n_1 = p_2 n_2$ . Now since pressure on a fluid is propagated in every direction, it is clear, that throughout the motion of the pistons, the fluid will be kept accurately in contact with their surfaces; for if there be, any where, no contact between the fluid and the surface of either piston, there will, there, be a free surface of the fluid, and nothing to sustain the pressure which has been propagated through it, to that surface; which is impossible.

The fluid being thus accurately in contact with the surfaces of the pistons throughout the motion, and being considered incompressible, it follows, that the motion of one of the pistons

\* This last case, in point of fact, resolves itself into the first, since the sides of the solid piston may be supposed to form a portion of the sides of a second vessel differently shaped from the first.

† It will be seen by reference to Art. 227, that the principle of virtual velocities, as proved there, applies accurately to the case of a machine constituted as that described in the text. The demonstration given there is, in fact, *perfectly general*. If we conceive the fluid to be without weight, the above reasoning holds for any extent of motion that may be communicated to the pistons.

must be such as just to make room for the fluid displaced by the other. Now, if we call  $\kappa_1$  and  $\kappa_2$  the transverse sections of the pistons, the quantity of fluid which that,  $P$ , which moves forward, will displace, will manifestly be that contained in a prism whose base is  $\kappa_1$  and length  $n_1$ ; and the space deserted by the other piston, by a prism having  $\kappa_2$  for its base, and  $n_2$  for its length. Now the volumes of these prisms are respectively,  $\kappa_1 \times n_1$  and  $\kappa_2 \times n_2$ .  $\therefore \kappa_1 \times n_1 = \kappa_2 \times n_2$ . And dividing the preceding equation by this, we obtain,

$$\frac{P_1}{\kappa_1} = \frac{P_2}{\kappa_2} \text{ and } \therefore \frac{P_1}{P_2} = \frac{\kappa_1}{\kappa_2} \dots \dots \dots (1).$$

If  $\kappa_1$  be equal to  $\kappa_2$ ,  $P_1$  is equal to  $P_2$ ; that is, if the plane areas to which the pressures are applied are equal, the pressures themselves are equal. Hence, from what we have said in the preceding article, the principle of the *equal* distribution of pressures is proved, whatever be the form of the surface to which it is applied.

245. From the above equation (1), it appears, that pressure applied to a plane surface in any one portion of a fluid, is to the pressure produced by it on a plane in any other portion of that fluid, as the area of the first plane is to that of the second. Thus, if the first area be very small as compared with the second, the force applied will be very small as compared with the force produced; and this increase of the *produced pressure*, in comparison with the *producing pressure*, may be carried to any extent, by increasing the disproportion between the two areas.

246. It is on this principle that Bramah's Hydrostatic Press is constructed. It is represented in the accompanying diagram.  $AB$  and  $CD$  are hollow cylinders, whose sides are of great thickness and strength. The diameter of  $CD$  is much less than that of  $AB$ , and they communicate through a pipe  $BD$ .  $AM$  is a strong solid piston, working in the hollow cylinder  $AB$ , by means of a water-tight collar, through which it passes at  $A$ , and terminating in a platform or extended surface,

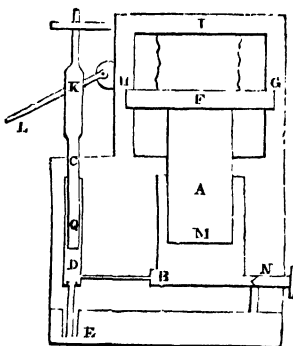

$GFH$ , which carries the substance to be pressed.  $KCQ$  is another piston similarly applied to the other cylinder  $CD$ , and

moveable in it by means of a lever  $\Pi K L$ , whose fulcrum is at  $\kappa$ . Immediately below the point  $D$  is a valve *closing downwards*, and beyond it, the cylinder  $C D$  is made to communicate by means of a pipe, with a reservoir containing water at  $E$ . The channel  $B D$  contains a valve *opening into the cylinder*  $A B$ . The lever  $\Pi K L$  being *raised*, the valve below  $D$  opens, and the water is made to ascend as in the common pump, from the reservoir  $E$  into the cylinder  $C D$ . The lever being then *pressed down*, the valve below  $D$  closes, that at  $B$  opens, and the water is forced through the channel  $D B$  beneath the piston  $M$ . When the whole of the fluid has been expelled from  $D$ , the operation is repeated; and thus the piston  $A M$  is made continually to ascend. The substance to be compressed is placed between the platform  $G F H$  and a cross-piece  $I$  which is fixed in the uprights  $G$  and  $H$ .

By what has been stated before (Equation 1, page 184), it appears, that the pressure upon the base of the piston  $M$ , is to that upon  $Q$  as the area of the former is to that of the latter. Now the pistons being solid cylinders, the areas of their transverse sections are to one another as the squares of their diameters. Hence, therefore, calling these diameters  $D_1$  and  $D_2$ , and the pressures upon them  $P_1$  and  $P_2$ , we have,

$$\frac{P_2}{P_1} = \frac{D_2^2}{D_1^2}.$$

Suppose, as an example, that the cylinder  $Q$  is one quarter of an inch in diameter, and  $M$  twelve inches,

$$\begin{aligned} \therefore \frac{P_2}{P_1} &= \frac{(12)^2}{\left(\frac{1}{4}\right)^2} = \frac{144}{\frac{1}{16}} \\ &= 144 \times 16 \\ &= 2304 \\ \therefore P_2 &= 2304 \cdot P_1. \end{aligned}$$

Now let us suppose the force  $P_1$  to be produced on the piston  $Q$ , by the action of a force  $P$  applied at the end of the lever  $\Pi K L$ , and let the length of that lever be 48 inches; and the distance of the point  $\kappa$  from its fulcrum  $\Pi$ , 4 inches: then (Art. 95),

$$\begin{aligned} 4 \cdot P_1 &= 48 P \\ \therefore P_1 &= 12 P \\ \therefore P_2 &= 2304 \times 12 \cdot P \\ &= 27648 P. \end{aligned}$$

If the force  $P$  applied to the extremity of the lever be one hundred-weight; the pressure  $P_2$  thus generated on the base of the piston  $M$  will be 27648 cwt., or more than 1382 tons. By

the mere weight of a man's body, when leaning on the extremity of the lever, a pressure may be produced by such an instrument as we have described, of upwards of 2000 tons. It is the simplest and the most easily applicable of all contrivances for increasing human power; and the only limit to the force which may be called into action by it, is the want of materials of sufficient strength to enable us to apply the enormous pressures which it generates. Had Archimedes been acquainted with it, he certainly would have preferred it to the lever, for raising the world with.

There is a beautiful contrivance of the late Mr. Bramah, for rendering the collars of the two pistons water-tight, under the enormous pressures to which the contained fluid is subjected. A portion of the leather with which the metal collar is lined, is made to extend beyond its edge into the fluid; one surface of this leather being thus presented to the action of the fluid, and the other to the surface of the piston, the pressure of the fluid causes it to clasp the piston more tightly than it otherwise would; and by this very simple contrivance, as the tendency of the fluid to escape is increased, by reason of the increase of the pressure upon it, the collar is continually tightened, and its escape more effectually prevented. The principle of the press had long been known\*; it was, however, the invention of this collar by Mr. Bramah, that first rendered it applicable to any useful purpose. It is used for the extraction of oils, for pressing paper, and for packing. Hay intended as provender for cattle on ship-board is reduced under this press to the state almost of a solid, and enormous quantities are thus brought into an inconceivably small compass. Besides the facility of stowing the hay thus compressed, there is this further advantage, that it may be kept without injury almost for any required time. There would seem to be no force known to us which may not be made to yield under this press; it requires but one of its least efforts to tear a tree up by its roots, or to break asunder a beam. It is sometimes used for extracting piles, and for trying iron cables. In this case it acts not by compression, but by traction; a somewhat different arrangement is therefore required to apply the pressure it generates. The *frame* of the machine is here fixed, and a rod, by which the force of traction is to be applied, is made to pass through a water-tight collar in the base of the cylinder MB, and attached to the extremity of

\* The discovery of it is usually attributed to Pascal; it belongs, however, to the celebrated Stevin, mathematician to the Prince of Nassau, the inventor of decimals.

the piston  $m$ , which in its motion carries this rod with it. The action of the machine is immediately relieved by turning a screw at  $n$ , by which the water is allowed to occupy a larger space, or to escape.

247. We have shown that pressure being propagated by the intervention of a fluid from one plane surface to another plane surface, these pressures are to one another as the areas of the planes. Now let us suppose the second surface not to be a plane, but a *curved* surface. Conceive it to be divided into an exceedingly great number of equal parts. Each of these may then be considered a plane. Let  $n$  represent their number. The pressure upon the first-mentioned surface which is a plane will be to the area of that plane, as the pressure upon either of the elementary planes to its area; and therefore as  $n$  times the pressure upon either of the elementary planes, is to  $n$  times the area of either of them, or as the whole pressure upon the curved surface to the whole area of that surface.

248. The pressure of a fluid upon the surface of a solid, is necessarily IN A DIRECTION PERPENDICULAR TO THAT SURFACE; for if it were not, then it might be resolved into two other pressures, one of which was *perpendicular* to the surface, and the other *parallel* to it; and this last would take effect upon the adjacent particles of the fluid, and cause motion among them. It follows, therefore, that the pressure of a fluid at rest upon the surface of a solid, is in a direction perpendicular to that surface.

## CHAPTER II.

### ON THE EQUILIBRIUM OF A HEAVY FLUID.

WE have laid down, in a preceding part of this work (Art. 159), as the *fundamental* principle of the equilibrium of a system of variable form; first, That the same conditions must obtain, with regard to such a system, as though its form were *invariable*. Secondly, That these must obtain *together with* such other conditions as arise out of *the nature of the variation* to which the system is subject.

249. Thus, a *fluid*, or any portion of a *fluid*, being a *system of variable form* held at rest by certain forces; the same conditions must obtain, with regard to these forces, as though its form were *invariable*—or in other words, as though it were

a solid; together with such other conditions as result from its

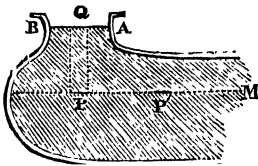

fluidity. Let  $AB$  represent a portion of the surface of a heavy fluid. Take a portion  $QP$  constituting a vertical column of this fluid having for its base a horizontal plane  $P$ , and let us consider the conditions of the equilibrium of that portion of the fluid. By the first condition of the equilibrium of a system of variable form, it follows that the same conditions must obtain, with regard to the forces acting upon this column of fluid, as though it were a solid. The sum of the forces impressed upon it in *opposite directions vertically*, must, therefore, equal one another; and also the sum of those impressed *horizontally*.

Now, supposing the surface  $AB$  of the fluid to be free of all pressure, the only *vertical* pressure upon the column  $QP$  *downwards* is its weight; and the pressure upwards upon it is the upward pressure of the fluid upon its base  $P$ . These are, therefore, equal to one another. That is, the pressure upon the base  $P$  of the column of fluid  $QP$  is equal to its weight; and this is true for every other column of the fluid similarly taken. Thus, then, it appears that the pressure upon a horizontal plane, any where taken in the fluid, is equal to the weight of the column reaching from that plane to the surface of the fluid.

250. Now, by the principle of the equal distribution of fluid pressure, the pressure upon such a plane would, if the fluid *were without weight*, be propagated *accurately*, without increase or diminution, to every other surface of equal area in the fluid.

The fluid is, however, *not* without weight; every particle of it is acted upon by the force of gravity, which force of gravity varies continually the amount of the pressure in its propagation from one portion of the fluid to another, provided the direction of that propagation be in any degree upwards or downwards, that is, in the vertical; but does not affect it, if its direction be horizontal, that is, perpendicular to the direction of gravity. Since, it is a *principle* of Statics, that forces, acting at right angles to one another, do not mutually *counteract* or *augment*, or, indeed, in any way affect, each other. This being the case, it follows that the pressure upon the plane  $P$  is accurately propagated, without increase or diminution, to any other surface  $P'$  of the same area, in the same horizontal plane with it. And, similarly, that the pressure upon  $P'$  is propagated to  $P$ . Hence,

therefore, we conclude that the whole pressure upon  $P'$  is precisely equal to that upon  $P$ .

For if it be not equal it must either be greater than it, or less. Let the pressure upon  $P'$  be *greater* than that on  $P$ . Then, since the pressure upon  $P'$  is transmitted to  $P$ , acting upwards on that plane, and exceeds its own pressure upon  $P$  downwards, it must give motion to it; but *it does not*, since the fluid is at rest.

Again, let the pressure upon  $P'$  be *less* than that on  $P$ ; then is the pressure upon  $P$  *greater* than that on  $P'$ , and for the same reason as in the first case, the plane  $P'$  must move; which it *does not*, since the fluid is at rest. The pressure upon  $P'$  is, therefore, neither greater nor less than that on  $P$ ; that is, it is *equal to it*.

251. From the above, then, it appears that THE PRESSURES UPON ANY TWO EQUAL AREAS, ANY WHERE TAKEN IN A HEAVY FLUID, ARE EQUAL TO ONE ANOTHER, PROVIDED THEY BE IN THE SAME HORIZONTAL PLANE\*. This is a fundamental proposition of Hydrostatics, and serves to explain the most important of the phenomena observable in the equilibrium of fluids on the earth's surface.

252. The pressure upon the surface  $P'$  being equal to that upon the surface  $P$ , also the latter pressure having been shown to be equal to the weight of the superincumbent column  $QP$ , it follows that the pressure upon  $P'$  is equal to the weight of that column, AND THAT THE PRESSURE UPON ANY HORIZONTAL AREA IS EQUAL TO THE WEIGHT OF A COLUMN OF THE FLUID WHICH WOULD REACH FROM THAT AREA TO THE FREE SURFACE OF THE FLUID. From this consideration we shall readily perceive that the pressure of a fluid upon the sides and base of the

\* There is another method of proving this important proposition, which although by no means so *elementary* as the above, will perhaps, be considered more intelligible.

Let  $P$  and  $P'$  represent equal and similar areas in the same horizontal plane, any where situated in a fluid; and let  $PQP'$  be an imaginary tube of any *symmetrical* form, and terminated by the planes  $P$  and  $P'$  which form its extreme sections. Suppose the whole mass of fluid, excepting only that contained in this tube, to become solid. The conditions of the equilibrium of the fluid contained in the tube will not be altered by this change, since it neither adds to the forces acting upon that fluid nor takes away from them, but merely supplies a power of *resisting further pressure*. Now, since the tube is *symmetrical*, it is apparent that the fluid in it cannot rest until the pressures upon its two extremities  $P$  and  $P'$ , be equal. Now  $P$  and  $P'$  are *any where* taken in *any horizontal plane*. The truth of the proposition is, therefore, apparent.





vessel which contains it may be increased enormously beyond the actual weight of the fluid.

253. Thus let  $AB$  represent a shallow vessel closed on every

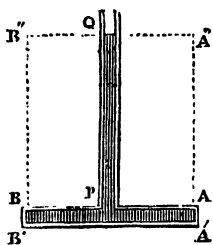

side except at the insertion  $P$  of a slender vertical tube  $QP$ . Let this vessel be filled with fluid, by pouring it into the tube until it stands in it at  $Q$ . The pressure upon the lowest section  $P$  of the tube is then the weight of the column  $QP$ . The pressure upon any surface equal to this section, and in the same horizontal plane,  $AB$ , with it, is, therefore, equal to the weight of this

weight of an imaginary column of the same height as  $PQ$ , and having the surface spoken of for its base; also the sum of the pressures upon all the similar surfaces, composing the plane  $AB$ , is equal to the sum of the weights of such imaginary columns. That is, it is equal to the weight of an *imaginary* mass [of the fluid occupying the whole space between  $AB$  and  $A''B''$ ].

The pressure thus produced upon the upper surface  $AB$  of the vessel is as much greater than the actual weight of the water in the tube  $PQ$  producing it, as that surface is greater than the section of the tube. Thus, if the tube were an inch square, and the surface  $AB$  contained one thousand square inches, or somewhere about seven square feet, then water poured into the tube weighing only a single pound, would produce upon  $AB$  a pressure upwards of one thousand pounds. A *cask* of almost any conceivable strength might thus readily be burst, by inserting in it a pipe, and filling the pipe with water to a considerable height. To whatever height we filled the pipe, we should in fact get a pressure, upon the head and base of the cask, equal to the weight of the column of water which it would contain if its height were continued to the level of the fluid in the pipe, retaining, in other respects, the same dimensions as at present.

The pressure which might be produced by this means is evidently without limit. It has been imagined possible that some of the great geological changes which have taken place on the earth's surface may *thus* have been brought about. Thus, if we conceive a huge cavern to occupy the heart of a mountain communicating, by means of a narrow fissure, with its surface at some point near its summit, or at any rate at

some point considerably above the level of the water in the cavern ; and this cavern in the course of time becoming filled with water, if we conceive some mountain torrent accidentally to take a direction over the mouth of the fissure so as to fill it also—or, as is possible, if we suppose the fissure to become filled by the continual oozing of the waters of the mountain into the cavern—the upward pressure thus produced upon the roof of the cavern may exceed the whole weight of the mountain, and, further, be sufficient to overcome its adhesion to its base. It will then be overthrown.

THE FREE SURFACE OF A FLUID IS EVERY WHERE ON THE  
SAME LEVEL.

254. The pressures upon equal areas in the same horizontal plane in a fluid being *equal* (Art. 162) ; also the pressure upon each of these areas being equal to the weight of *any* column, having a base equal to that area, and reaching to the free surface of the fluid ; it follows that all such columns must be of the same *weight*, and therefore of the same *height*. Thus then, it appears that all vertical lines drawn, from the same horizontal plane, to points in any portion of the free surface of the fluid, (that is, to any portion of the surface not retained in its position by the resistance of the sides of the vessel,) are *equal* to one another ; that is, all such points are at the same height above the horizontal plane spoken of. They are, therefore, themselves in the *same horizontal plane*, or, according to a technical expression, they are on the *same level*. Thus, in the figure page 188, the different points in the surface  $AB$  which is supposed to be free, are on the same level, or in the same horizontal plane ; and the fluid being supposed to be continued towards  $M$ , if there be any other portion of it whose surface is also free, that surface will be in the same horizontal plane, or on the same level, with  $AB$ .

255. The *common surface* of two fluids of different densities is a horizontal plane ; for the free surface of the upper fluid is a horizontal plane ; also, if a horizontal plane be taken in the lower fluid, the pressure upon every equal area of *this* plane is the same, and is equal to the weight of a vertical column extending from it to the surface of the fluid ; hence the weights of all such columns are the same. Now they are of equal length, since they extend to the free surface of the upper fluid, which is shown to be a horizontal plane. Since, then, they are of equal length and of equal weight, each must contain the same quantity of each fluid ; and the heights of the lower columns,

that is, the distances of different points in the *common surface* of the two fluids from a given horizontal plane, must be the same; and, therefore, that *common surface* must itself be a horizontal plane. Thus the *common surface* of liquids on the earth's surface, and the atmosphere which surrounds it, is a horizontal plane.

256. There is no conceivable variety in the *form* of the containing vessel to which the reasoning on which these conclusions are founded is not applicable.

Thus, the whole may form a *system of pipes*, connecting different reservoirs with one another; and it follows, from what has been said, that whenever the water has attained a state of equilibrium in these reservoirs, its surface, in all, will be in the same horizontal plane, or it will stand at the same level, in all. The fluid will be in motion until this is the case. Whilst thus in motion, it is said to be *seeking its level*.

257. This property of a fluid, by reason of which it seeks its own level, is that property by which it is made to diffuse itself with such wonderful facility through the streets of our crowded cities, overcoming every obstacle which the varying elevation of the ground presents to its motion; ascending frequently into the higher apartments of the houses, and feeding, at stated intervals, a reservoir which supplies to each house a fountain abundantly sufficient for all the purposes of cleanliness and health. To effect this, all that is necessary is to cause the whole system of pipes to communicate with a reservoir of the fluid, whose surface is above the highest level to which it is required to be raised. If a sufficient supply of water cannot be made to flow of its own accord into such a reservoir, it must be *raised* into it by action of pumps or otherwise; this is done, in the water-works which supply the metropolis, by the aid of steam-engines.

It is remarkable that this important property of fluids, on which the health and comfort of a crowded population so much, nay, so essentially depends, should have been so long a secret in the world. It would seem not to have become known until within a few centuries. That the Romans never suspected its existence, or, at any rate, that they never thought of applying it to those great purposes by which, in our day, it is made to contribute so largely to the well-being of society, is evident from the great number of stone aqueducts erected by them, at immense labour and expense, in the neighbourhood of all their great cities, of which the ruins are among the most striking monuments at once of their power, their wealth, and their

ignorance, that remain to us. The aqueducts which supplied Rome alone were, together, several hundred miles in length, and the aqueduct built by them in the neighbourhood of Nismes, called the Pont du Gard, is one of the most lofty and massive existing specimens of masonry. All these aqueducts were artificial channels made, upon the same level, from the top of one eminence to that of another, and supported upon pillars over the intervening valley. It is inconceivable that they should not have spared themselves the erection of these gigantic structures, had they been aware that a closed channel, however tortuous or irregular its direction, and however varied its level, would carry a stream as certainly from one point to another, at the same elevation, as though its whole course were made to be a horizontal straight line.

258. The property of fluids by which they seek their own level may be strikingly illustrated by means of the instrument represented in the accompanying engraving. A variety of vessels of different forms are made to communicate with a common reservoir which is closed on every side.

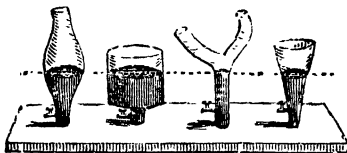

However varied and irregular the forms of these vessels may be, it will be found that water poured into the reservoir through one of them, and more than filling it, so as to occupy a certain space in each vessel, will not rest until it stands at the same height, or on the same level, in all. This experiment may be varied by placing stop-cocks in the necks of the different vessels, as shown in the figure. The reservoir being filled, and these stop-cocks closed, the fluid should be poured into each vessel so as to stand in each at a different level; the stop-cocks being then opened, the surface of the fluid in each vessel will be observed to be instantly in a state of motion; and after some time oscillating about their positions of equilibrium, *all* the surfaces will be observed, finally, to rest in the same horizontal plane.

259. The locks used on canals present another illustration of this principle. Since a fluid will rest only when its surface has attained, every where, the same level, it is evident that the waters of a canal will remain stagnant only so long as its channel is such as to admit of this equality of level in its surface; or in other words, only so long as its channel is such that a horizontal plane, made to pass through a point

at which the surface of the fluid in the canal is intended to stand, in one place, and being produced in the direction of its course, shall every where else cut its *banks*, or the *sides* of its channel, in some point or other; no where lying above or beneath them. For the surface of the fluid being at one point in this horizontal plane, will not rest unless it be every where else in the same plane; if, therefore, the plane be any where above the banks of the canal, the surface of the fluid will there ascend above the banks, or the canal will *overflow*; and if the plane lie any where *beneath* the sides of the channel, so as to intersect the bottom of the canal, the *surface* of the fluid will *there* also intersect the bottom, or the canal will there be dry.

Now it is sometimes impossible to construct the channel of a canal so as to be subject to this condition, by reason of inequalities in the surface of the country through which it passes. Two distinct portions of the channel are then made on different levels; one, for instance, is on the level of the top of a hill, while the level of the other is that of the surface of the valley beneath it. The two branches of the canal being thus wholly distinct and separate from one another, the difficulty lies in transferring the barges which ply upon it, from one branch to the other. This is sometimes effected by making a railroad down the side of the intervening hill, floating the barge upon a sort of cradle, which may be made to move upon wheels, or otherwise, upon the railroad, then lifting the whole out of the water by means of a steam-engine; and by the aid of the same power, allowing it to slide down the inclined plane into the channel in which it is to continue its course, or raising it up the plane into the channel which is upon the higher level, if its course be in the opposite direction. One loaded barge is thus, sometimes, made to draw up another.

The more common, and by far the most convenient contrivance for transferring the barges from one branch of a canal to the other, is, however, that of the canal lock. Let

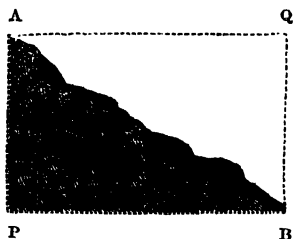

AB represent the surface of the hill lying between the two branches of the canal. If the difference of levels be not considerable, an excavation is made from the summit A perpendicularly downwards in the direction AP to the level PB of the bottom of the hill, and at the same time a mound is raised on either side of this excavation,

the top of which  $q a$  is on the same level with  $a$ . And this being done on both sides of the excavation, a great trough or reservoir is formed whose bottom is on the same level with the bottom of the lower branch of the canal, and its top on the same level with the top of the upper branch. The extremities of this reservoir are closed by gates  $κ c$  and  $i d$ , hung upon hinges at the side. A barge is brought from the higher level  $a b$  to the lower  $e f$ , thus; the gates are closed, and a subterranean channel between the upper branch of the canal and the

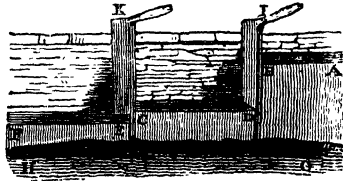

lock, is at the same time opened; through this channel the water flows into the lock until its surface  $c d$  rises to the level of the surface  $b a$  of the water in the higher canal; the gate  $i d$  is then opened, which may be readily done, since the water standing on the same level on either side the gate, presses equally on both sides; and, therefore, does not, by reason of its pressure, oppose any obstacle to the motion of the gate, or in any way accelerate it. The gate being thus opened, the barge is drawn into the lock, and the gate closed again behind it. The lock thus becomes a closed vessel of fluid supporting the barge on its surface. A communication is now opened between it and the lower level of the canal, and its surface is thus made gradually to descend, carrying with it the barge, until its level is the same with that of the water in the lower canal; the gate  $κ c$  is then opened and the boat floats out of the lock into that canal.

260. The process of raising a barge from the lower to the upper level is just the converse of this. The lock being, as it is termed, empty, the level  $c d$  of the water in it is the same with that  $e f$  of the lower canal; the gate  $κ c$  being, therefore, opened, a barge may be floated from that canal into the lock. This having been done, the gate is closed again, and the channel communicating between the lock and the upper canal is opened; the lock is thus gradually filled, and as the surface of the water in it rises, it carries with it the barge until it has at length lifted it to the level  $a b$  of the surface of the water in the upper canal; the gate  $i d$  being then opened, it is at once floated into that canal.

¶ If the difference of levels be considerable, it is found impracticable to excavate and embank a single lock of sufficient depth to effect the transfer of the boat at once. A series of

locks are, in this case, constructed, and the boat is made to pass immediately from one into the other, until it has been moved, as though by so many distinct steps, up or down the side of the intervening hill. A barge might thus be made to ascend on one side of a hill, and descend on the other, or in other words, to float over it, were there a sufficient supply of water at the top of the hill to supply the loss which takes place at every transfer.

It is evident that whenever the lock is emptied, a lock full of water is transferred from the higher canal to the lower, and since, every time a boat descends, this emptying must necessarily take place, and no two successive ascents can take place without it, it follows that unless there be a continual supply of water to the upper canal, so as to replace the water which is thus continually taken from it, that canal must soon be emptied and rendered useless. This is the great obstacle to the use of locks; it is of course difficult, in many cases, to obtain the requisite supply of water at the higher level of a canal, and sometimes it is impracticable.

261. The water level presents a very useful application of the property of fluids, by which they seek their own level. It is necessary in certain operations of drainage and levelling to ascertain the exact point of an object, a bank or wall for instance, which is in the same horizontal plane with another point at some distance from it. This is sometimes done as

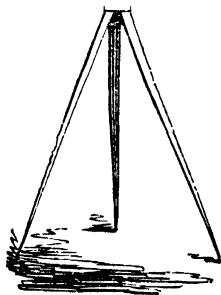

follows; a tube  $AB$  of the curved  $Q$  form represented in the figure, and having the extremities  $A$  and  $B$  of glass, is fixed on a stand, and placed so that a small quantity of fluid being poured into the tube the point  $P$  by which the level of the other is to be fixed, shall appear to an eye looking over the two surfaces  $A$  and  $B$  of that fluid, in the same right line with them. If the observer now look in the opposite direction from  $B$ , over the surface  $A$ , the point  $Q$  of the object which

he sees in the same right line with  $B$  and  $A$ , is in the same horizontal line with  $P$ . This is the instrument commonly used by labourers in drainage. It is easily made and applied, and no instrument can exceed it in theoretical accuracy.

## CHAPTER III.

262. The Oblique Pressure of a Heavy Fluid.  
 263. The Forms of Vessels containing Fluid.  
 265. The Forms of Embankments and Dams.  
 267. Centre of Pressure.  
 269. Whole Amount of Pressure on any given Surface.  
 271. Composition and Resolution of the pressure of a Heavy Fluid.
272. The Horizontal Pressures upon a Body immersed in a Fluid, destroy one another.  
 273. Amount of Horizontal Pressure.  
 278. Effect produced by removing a Portion of the Sides of a Vessel containing Fluid.  
 280. Barker's Mill.  
 281. The Motion of Rockets.

## ON THE OBLIQUE PRESSURE OF A HEAVY FLUID.

262. LET  $PQ$  be a plane surface situated *obliquely* in a fluid; and let  $PQ'$  be another plane taken in the fluid precisely of the same dimensions as  $PQ$  but situated *horizontally*. The pressure upon  $PQ'$  will then, by what has been said before (Art. 248), be equal to the weight of a column of the fluid having that plane for its base, and reaching to the surface  $M$ . Now all this pressure will, by the principle of the equal distribution of fluid pressure, be transmitted to the surface  $PQ$ , augmented by the pressure arising from the weight of the fluid  $PQ'Q$  between the two planes. If, therefore,  $PQ$  be infinitely small, since this last-mentioned portion of the fluid will be infinitely small, it follows that its weight may be neglected, and the pressure upon the plane  $PQ$  considered accurately equal to the weight of a column of fluid having that plane for its base, and a height equal to the depth  $PM$  of the plane.



Now the pressure of a fluid upon a surface is in a direction *perpendicular* to that surface. (Art. 248.) Taking, then, a column  $PM'$  perpendicular to  $PQ$ , having that plane for its base, and being of a height  $PM'$  equal to  $PM$ ; the pressure upon  $PQ$  will act in the direction of that column, and be equal to its weight. The surface  $PQ$  being supposed exceedingly small, the column  $PM$  may be represented by the *line*  $PM$ .

263. Let us suppose  $PP_1P_2$  to be points in the interior



surface of a vessel containing fluid. Draw  $PM'$ ,  $P_1M'_1$ ,  $P_2M'_2$ ,

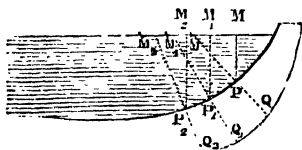

perpendicular to the surface in these points, and equal severally to their depths  $PM$ ,  $P_1M_1$ ,  $P_2M_2$ . These perpendiculars will then represent the pressures upon exceedingly small portions of the surface about

those points. (Art. 262.) It is manifest that these lines increase as the points are deeper beneath the surface; if, therefore, the vessel is to be constructed so that it shall have no more tendency to yield to the pressure of the fluid at one portion of its surface than at another, its *thickness* must be greater towards its lower portions than its upper. Also, if we suppose the strength of the vessel to be *proportional* to its thickness, it is clear that we must take the thicknesses  $PQ$ ,  $P_1Q_1$ ,  $P_2Q_2$ , at the points  $P$ ,  $P_1$ ,  $P_2$ , proportional to the lines  $PM'$ ,  $P_1M'_1$ ,  $P_2M'_2$ , that is, to the lines  $PM$ ,  $P_1M_1$ ,  $P_2M_2$ . If we would have the thickness every where *just that* which will sustain the pressure of the fluid and no more, we must ascertain, by experiment, what thickness of the material will just sustain the pressure at any one point, as for instance  $P$ , and then take the thicknesses at all the other points to their depths in the same ratio that this thickness is to its depth

264. If the side of the vessel, or any portion of it be a *plane* instead of a curved surface, the law of the variation of the pressure is very easily determined. Suppose  $APD$  to be a ves-

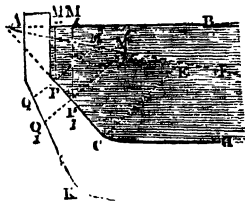

sel of whose interior surface, the proportion  $PC$  is a plane. Let  $AB$  be the surface of the fluid, and let it be imagined to be produced, so as to meet the plane  $PC$  produced, in  $N$ . Through any point  $P$ , in  $PC$ , draw the vertical  $PM$  to the surface of the fluid, and draw  $PM'$  perpendicular to  $PC$ , and equal to  $PM$ . Then, if from  $N$  there be drawn a line  $NL$  passing

through the point  $M'$ , a perpendicular  $P_1M'_1$ , drawn from any point  $P_1$  in  $PC$  to this line, will represent the pressure upon that point; being equal to the height of a column  $P_1M_1$  whose weight equals that pressure. If we fix upon  $PQ$  for the thickness of the vessel at  $P$ , and draw from  $N$  a right line  $NK$  through  $Q$ ; then, if the outside surface of the vessel be made to coincide

with this line, its power to sustain the pressure upon it will be the same at every other point of  $PC$ , as at  $P$ : that is, the vessel will be equally strong throughout; for  $P_1 Q_1$  has to  $P_1 M_1'$  the same ratio which  $PQ$  has to  $PM'$ .

265. It is on this principle that embankments and dams, —which are mounds of earth or other material intended to support the pressure of a fluid,—are not built up perpendicularly, and all of the same thickness, but made to have their *outer* surface uniformly sloped. A perpendicular  $PM$  being drawn from any point  $P$  of the interior surface  $AB$  of the dam, and made equal to the depth  $PA$  of that point, also a line  $AL$  being drawn from  $A$  through  $M^*$ ; perpendiculars drawn from all the other points in  $AB$  terminated by this line, will equal the respective depths of those points; as that from  $P$  equals its depth. Also, if *any* line  $AN$  be drawn from  $A$ , the distances between this line and the different points of  $AB$  will be all proportional to the depths of those points; an embankment, then, terminated by any such line  $AN$  would be every where of the same strength to resist the tendency of the fluid to burst through it†. Embankments are, of course, usually made as represented in the figure, wider than is requisite to give them an uniform strength, in order that allowance may be made for any variation in the resistance of the material of which they are composed.

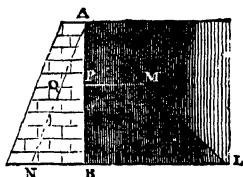

266. From the above it will be apparent that surfaces of all kinds sustaining the pressures of heavy fluids should be made stronger towards their lower than their upper parts, the strength necessary for the latter being thrown away upon the former. Thus, flood-gates and lock-gates should have heavier beams and fastenings, and barrels and vats should be more strongly hooped, at the bottom than at the top.

### THE CENTRE OF PRESSURE.

267. LET us now return to the case of the pressure upon a plane surface forming part of the sides of a vessel, as represented in the figure preceding the last; a question arises as to

\* This line will evidently be inclined to the surface of the fluid at an angle of  $45^\circ$ .

† The tendency of the pressure of the fluid to *overturn* the embankment is not here taken into account. It materially influences the form which should be given to it.

what is the amount of pressure sustained by the *whole* of that plane; and *where* a single force should be applied so as to sustain that pressure, and hold the plane at rest; even although it were entirely detached from the rest of the vessel. The point which possesses this property is called the centre of pressure; it may be defined generally to be *that point in a surface sustaining the pressure of a fluid where a single force might be applied so as to sustain the whole of that pressure and keep the surface at rest*. Its position may, where the surface is a plane, be very readily determined. It has been shown that the pressures upon the several points of the plane  $PC$  (see the figure page 198,) will be represented by lines drawn perpendicular to that plane and terminated by  $NL$ , and will, in fact, be equivalent to the weights of columns of the fluid of the same lengths with those lines; the whole pressure is, therefore, equal to the weight of the whole figure  $PCEM'$ , which may be supposed to be made up of such lines, and its effect upon  $PC$  is precisely the same as would be produced by the weight of such a figure if it were placed upon it in a horizontal position. Now the resultant of the weights of the parts of this figure would pass through its centre of gravity; the resultant of the pressures of the fluid upon  $PC$  passes, therefore, through this centre of gravity. We have only then to find the centre of gravity of the figure  $PCEM'$  (called a trapezium), and draw a perpendicular from this point upon  $PC$ ; the point where this perpendicular meets it, will be its centre of pressure.

268. If the plane  $PC$  extend to the surface of the fluid at  $N$ , the determination of the position of the centre of pressure will be very easy, for then the point  $P$  will coincide with  $N$ , and

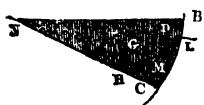

the trapezium  $PCEM'$  will become the triangle  $NC D$  (see the accompanying figure). The centre of gravity of this triangle we know how to find, by the method explained in Art. 68. Now the position of the point  $G$  in the figure of that article is

distant from the vertex  $A$  of the triangle by two-thirds of the whole length of the line  $AM$ , which is drawn from  $A$  bisecting the opposite side  $BC$ . Hence, therefore, if in the *above* figure we draw  $NM$  bisecting  $CD$  in  $M$ , and take  $NG$  equal to two-thirds of  $NM$ ,  $G$  will be the centre of gravity of the triangle, and drawing  $GH$  a perpendicular upon  $NC$ ,  $H$  will be the centre of pressure of that plane. Now, since  $NG$  equals two-thirds of  $NM$ , it is evident that  $NH$  must equal two-thirds of  $NC$ . Hence, therefore, it follows that the centre of pressure of a plane, reaching to the

very surface of the fluid whose pressure it sustains, is at a distance from its upper extremity equal to two-thirds of its whole length. Of course the plane is supposed to be composed of lines throughout its whole breadth of the same length with  $nc$  and parallel to it; or in other words, it is supposed to be a rectangle; and this being the case, whatever be its inclination, its centre of pressure will be distant from its higher edge by two-thirds of its whole length, and a single force, as, for instance, the pressure of a rod, applied at that distance, and in the middle of its breadth, would hold the plane at rest. And the same would manifestly be the case if the rod, instead of being applied to it longitudinally at a single point, were placed across it over that point. All that is required to the equilibrium being that the centre of pressure should have a sufficient force applied to it.

269. We have stated the centre of pressure of a rectangular plane to be at two-thirds the length of the plane from the surface of the fluid, whatever may be its inclination: this is true, therefore, if the plane be *vertical*. Thus, a sluice or flood-gate, might be held in its place by the pressure of a single force against it (the end of a rod for instance), at two-thirds of the depth of the fluid, and in the middle of the breadth of the gate. Also, if the gate turned upon a horizontal axis passing across it at that point, it would keep itself closed notwithstanding the freedom of motion which it admits of about that axis. And if the reservoir contained too much water, having allowed that water to escape down to the proper level, it would, by its own pressure, close itself.

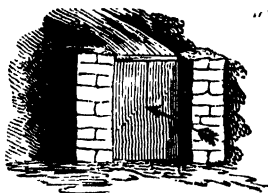

The beams and hinges of a lock-gate should manifestly be placed, not at equal distances from the top and bottom of the gate, but at equal distances above and below its centre of pressure, which is at two-thirds its depth. This arrangement is of great practical importance, nevertheless it does not seem to be attended to. On the same principle it appears that the staves of a barrel or vat would be held together by a single hoop, if that hoop were situated at two-thirds the depth of the contained fluid. If, as is commonly the case, the lower extremities of the staves be prevented from revolving *inwards* by the resistance of the bottom of the cask, the hoop *may* be placed anywhere *beneath* the centre of pressure; it will, however, be best placed when nearest it, and must not be *above* it. Where, as in the

case of a vat, the vessel is always to remain supported on one extremity; the hoops should be placed symmetrically with regard to the centre of pressure. In the case of a barrel, which is supported sometimes on one extremity and sometimes on the other, we may divide its whole height into three parts, and place the hoops at the divisions. If more hoops be required, they should be placed half-way between the others. The strongest hoops are of course required at the extremities. In the above we have supposed the staves to be straight. If this be not the case, the results stated above will require to be *slightly* modified.

THE WHOLE AMOUNT OF PRESSURE SUSTAINED BY THE  
SIDES OF VESSELS.

270. WE have shown that the pressure of a heavy fluid upon an exceedingly small plane, however situated, is equal to the weight of a column having for its base the area of that plane, and for its height, the depth to which the plane is immersed. (Art. 262.) Now the volume of such a column is equal to the product of its base by its height. Hence, therefore, it follows that the pressure upon any small plane  $P$ , whose depth is  $D$ , is equal to the weight of a quantity of fluid whose volume is represented by the product  $P \times D$ . Also, if we suppose a surface sustaining the pressure of a fluid, whatever may be its form, to be made up of any number of such planes; then the whole pressure upon that surface is equal to the *sum* of all such products; that is, to the sum of the products obtained by multiplying each elementary plane by its depth, or rather to the weight of a volume of fluid equal to this sum. Now *the sum of these products* is equal to the product of the *whole surface multiplied by the depth of its centre of gravity*. Hence, if we suppose the whole surface to be spread out, and a column taken having this surface for its base, and for its height what was before the depth of the centre of gravity of the surface, then the whole pressure will equal the weight of this column filled with fluid.

We have thus a very easy method of determining the whole pressure of a fluid upon a surface, if we know the position of its centre of gravity. For instance, if a sphere be immersed in a fluid; since we know that the depth of the centre of gravity of its surface is that of its centre, we know also that the pressure upon it is equal to the weight of a quantity of fluid which would be contained in an upright vessel having a base equal to the surface of the sphere, and having for its height the depth of the centre of the sphere.

Suppose the sphere only to be just immersed, or just covered

with the fluid, the depth of its centre of gravity will then equal its *radius*; hence, therefore, by what has been said above, the pressure upon it will equal the weight of an upright column of the fluid having a base equal to the *surface* of the sphere, and a height equal to its *radius*. Now the volume of the fluid which the sphere will contain is known, by the principles of geometry, to equal a similar column having the same base, but having a height equal to two-thirds the radius. Hence, therefore, it appears that the pressure upon the sphere is greater than the weight of the fluid it would contain; being to that weight in the ratio of 1 to the fraction  $\frac{2}{3}$ , or in the ratio of three to two.

It is evident that all the above reasoning, and all the conclusions made to depend upon it, apply to the case of a *hollow* sphere filled with fluid; the pressure being here from *within*, *outwards*, instead of from *without*, *inwards*. The pressure upon such a spherical vessel is, therefore, greater than the weight of the fluid it contains, in the ratio of three to two.

Let us now suppose a vessel, in the shape of a pyramid, to be placed upon its base, and filled with fluid to its vertex. We have seen before (Art. 268,) that the distance of the centre of gravity of one of the triangular faces of such a pyramid, from its vertex, is equal to two-thirds of the length of a line drawn from the vertex to the bisection of the base. Hence it is easily seen that the vertical depth of the centre of gravity of the face, beneath the vertex of the pyramid, is equal to two-thirds the whole height of the pyramid. The pressure upon each face is, therefore, equal the weight of an upright column of the fluid, whose base is that face, and its height two-thirds the height of the pyramid. The base of the pyramid has its centre of gravity at a depth beneath the surface of the fluid equal to the whole height of the pyramid; the pressure upon it is, therefore, equal to the weight of an upright column of the same base and height with the pyramid.

If the faces of the pyramid be all equal, the sum of the pressures on the sides will equal the weight of three columns, each having a base equal to either face, and a height equal to two-thirds the height of the pyramid, or it will equal a single column having that base, and being in height, twice the height of the pyramid. Now the pressure upon the base has been shown to equal the weight of a column of the same base, and having the *same* height as the pyramid. Hence, then, the pressure altogether upon the sides and base is equal to the weight of a vertical column having a base equal to either face of the pyramid, and being three times its height. The pyramid



upon  $PQ$  in the direction  $PF''$ ; that is, in a direction perpendicular to a given plane, is equal to the pressure upon the projection  $P''Q''$  of  $PQ$  upon that plane.

272. Now all that has been said above is true, whatever be the magnitude of the portion of the surface  $PQ$ . Let, then,  $PpQ$  and  $PqQ$  be those two portions of the surface of the mass which have the same projection  $P''Q''$ . The pressure of the fluid upon  $PpQ$ , resolved in a direction perpendicular to the given plane, is then, by what has been said before, equal to, and identical with, the pressure upon  $P''Q''$ ; and it manifestly acts in a direction *towards*  $P''Q''$ . Again the resolved pressure upon  $PqQ$  is equal to, and identical with, the pressure upon  $P''Q''$ , but acts in the opposite direction, or *from*  $P''Q''$ . The mass is, therefore, pressed in directions perpendicular to the given plane, by forces which are in every respect equal, and identical, and *opposite* to one another. It does not, therefore, move by reason of these pressures either *towards* or *from* that plane; and that plane is *any* vertical plane. The pressure of a heavy fluid upon a mass immersed in it, or upon the sides of the vessel which contains it, has, therefore, no tendency to give motion to it, *towards* or *from* any vertical plane which can be taken in the fluid; that is, to cause motion in it in any *horizontal* direction whatever. And such we find, by experience, to be the case; if we plunge a body, however light, or however irregularly formed, into a fluid, we experience no tendency of the body to move either to the right hand or the left; provided the fluid be at rest, and it sustain no other pressure than that which is supplied by the fluid itself.

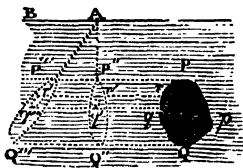

273. The actual amount of the horizontal pressure upon any portion of the surface of a body, and in every direction, we can readily ascertain. From the intersection  $A$  of the plane of projection with the surface of the fluid, let a plane  $AQ'''$  be drawn, inclined at an angle of forty-five degrees to the surface. It has been shown (Art 267) that the pressure upon any portion of the plane  $P''Q''$  will equal the weight of the fluid lying horizontally between that portion of the plane and  $AQ'''$ . Thus the whole pressure upon  $P''Q''$ , that is, the whole horizontal pressure upon either side of the mass  $PQ$ , is equal to the weight of the column  $P'''P''Q''Q'''$ . And, similarly, the pressure upon any portion of the surface, as  $qr$ , whatever be its



magnitude, is equal to the weight of the column  $q' q'' r'' r'$ . Since the pressures upon the several portions of the mass are equal, each to the weight of a corresponding column of the mass  $p'' p''' q''' q''$ , it follows that the resultant of the pressures is equal and opposite to the resultant of the weights. The resultant of the pressures upon the different parts of the mass, resolved in directions perpendicular to  $p'' q''$ , passes, therefore, through the centre of gravity of  $p'' p''' q''' q''$ .

274. There are some cases in which this consideration will enable us, very readily, to fix upon the direction of the horizontal resultant. Thus, if the surface  $p q$  had been that of a cone, the projection  $p'' q''$  and also the section  $p''' q'''$  would have been triangles; and if the vertex  $p$  of the cone, had coincided with the surface of the fluid, then the figure  $p'' p''' q''' q''$  would have resolved itself into a pyramid; whose centre of gravity

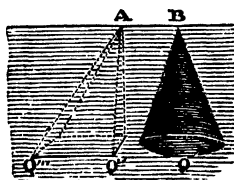

would have been at a distance from its vertex, equal to three-fourths the height of the pyramid. In the same manner if the surface  $p q$  had been a sphere, the mass  $p'' p''' q''' q''$  would have been the frustum of a cylinder, the position of whose centre of gravity is easily ascertained by the known rules. In both these cases we may, therefore, determine the direction of the resultant of the horizontal pressures upon the surface. Thus, if a hollow cone, or a hollow sphere, were to be sunk in a fluid, and we would wish to know where pieces should be placed across in its interior surface, so as best to strengthen it, we might determine, as above, the directions of the resultants of the horizontal pressures all round it, and it would manifestly be in these directions, or symmetrically with regard to them, that the cross pieces should be placed.

275. All that has been proved above applies, whether we suppose the pressure of the fluid to be from *within* the surface  $p q$  *outwards*, or from *without*, *inwards*. The former is the case of a *vessel* containing fluid; the latter of a body immersed in it. Thus, then, if a cone-shaped vessel were filled with fluid, we know that the resultant of the horizontal pressures upon its sides passes through a point distant from its vertex by three-fourths of its height; and if we applied two forces, of sufficient magnitude, horizontally, on opposite sides of it, at this distance from its vertex, and a sufficient force downwards at its vertex, then cutting the vessel asunder from the vertex downwards, we

should find that the parts would not be forced asunder. Similarly, we might cut a sphere, filled with fluid, vertically, through the middle, and hold the parts together by means of two horizontal forces.

276. These principles have manifestly a great variety of useful practical applications. They will guide us in fixing the beams of ships, in strengthening the parts of large vessels intended to contain fluid—the vats, for instance, used by brewers and distillers—in the building of dykes, locks, &c. In fact, there is no branch of Hydraulic Architecture which can be attempted, on a large scale, with common safety, by a person not thoroughly versed in the principles of Hydrostatics.

277. We have hitherto supposed the fluid to press upon every portion of the solid immersed in it, or upon every portion of the vessel which contains it. And on this hypothesis we have shown that the horizontal pressures of the fluid will mutually destroy one another. The hypothesis which forms the basis of this conclusion does not necessarily obtain in all cases; for let us suppose the body to be hollow, and a portion of its surface as  $PQ$  to be removed, and let  $P'Q'$  be that other portion of the surface which has the same vertical projection as  $PQ$ . The surface  $PQ$  being removed the pressure upon it will be removed, and the horizontal pressure upon  $P'Q'$  will no longer be sustained by any equal and opposite pressure; it will, therefore, communicate to the body a tendency to move in the direction  $r'r$ ; and this tendency will continue, in a greater or less degree, until, by the influx of the fluid at the aperture  $PQ$ , the vessel is *filled*, or at any rate until the level of the fluid *within* is the same with that *without* it\*. So that a vessel, with an aperture in it, being plunged in a fluid, will tend to move towards the direction in which that aperture lies; a ship, for instance, which has sprung a leak, will be found to have a motion sideways *towards* the direction of the leak; and this will be the more observable if she be continually emptied by the pumps. If the leak be of large dimensions, the motion

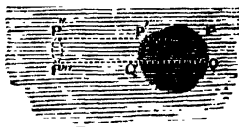

\* The fluid during the whole of its influx exercises a certain pressure upon the edges of the aperture, and when it has attained, internally, the level of the aperture, there is a further pressure of the *influx* upon the *contained* fluid, both of which *tend* to sustain the pressure upon  $P'Q'$ ; so that we cannot consider that, by removing the portion  $PQ$  of the surface, we entirely remove from the body the pressure which it before sustained on that portion of its surface.

arising from this cause will be found to constitute an important item in the ship's reckoning. Indeed, a vessel might be impelled onwards through the water, with no other impelling force than that arising from an unequal pressure of the water upon her head and stern, produced by breaking a hole under her bows, and continually pumping out the water which flowed into her hold.

278. All the above reasoning is applicable to a vessel containing fluid; the only difference lies in this, that in the case of such a vessel the pressure is from within *outwards*, whereas in the other case it was from without *inwards*. Thus, if  $PQ$  and

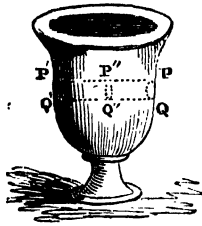

$P'Q'$  represent portions of the sides of such a vessel having the same projection  $P''Q''$  upon any given vertical plane; then, from what has been said above, it appears that the horizontal pressures upon these planes perpendicular to the given plane are equal, each, to the pressure of the fluid upon the projection  $P''Q''$ , and that they are in opposite directions. Since, then, the opposite portions  $PQ$  and  $P'Q'$  of the sides of the vessel are acted upon

by equal and opposite horizontal forces, these have no tendency to communicate motion to it; but if either of these portions of the vessel be removed, the horizontal pressure upon its opposite and corresponding portion will be unsustainable, and will tend to overthrow it; and this will continue to be the case, in a greater or less degree, as long as the surface of the fluid remains above the level of the aperture. The vessel may thus be upset.

279. We may experimentally put this fact of the horizontal

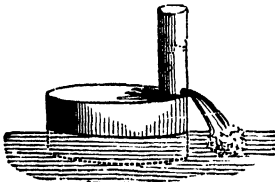

pressure produced by opening an aperture in the side of a vessel of fluid to the test, by causing such a vessel to float on the surface of a fluid by means of another empty vessel, as in the accompanying cut. The floating vessel and its contents, will be found to move in a direction opposite to that of the efflux.

The celebrated Bernouilli conceived the idea of propelling ships in this manner. Water was to be raised in them by pumps, or otherwise, and then allowed to flow from a reservoir in a direction opposite to that of the intended course of the ship. If allowed to enter under the bows, and (after having

been raised) allowed to escape by the stern, the vessel would be propelled both by the *influx* and the *efflux*, for the reasons explained, as well in this as the preceding article.

280. There is an exceedingly valuable instrument called Barker's mill, which acts upon a principle analogous to the

above.  $AB$  is a hollow cylinder moveable about a vertical axis  $MN$ ;  $PP'$  is another cylinder placed at right angles to the former, and communicating internally with it. Near its extremities, which are closed, two apertures are made in the *sides* of this horizontal cylinder, opening in opposite directions. That at  $P$  is supposed to front the reader; that at  $P'$  is supposed to lie

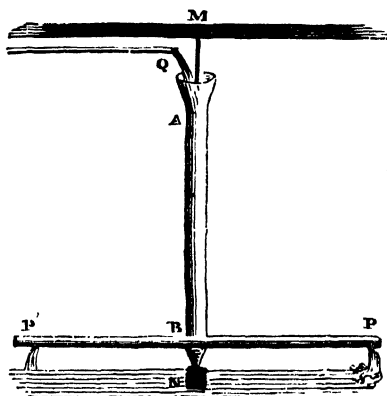

on the opposite side of the tube from that on which he looks. Let us now suppose the whole to become filled with fluid up to a certain height in the vertical tube, the apertures  $P$  and  $P'$  being both closed. The horizontal pressure upon every portion of the horizontal cylinder  $PP'$  will then, by the last article, be sustained by an equal and corresponding pressure on an opposite portion of it; and the cylinder will, therefore, have no tendency to motion arising from the pressure of the fluid upon its sides. But if one of the apertures, as  $P$ , be opened, the pressure upon that portion of the surface which is removed to form the aperture, will be removed, the pressure upon the opposite portion of the surface will be *unsustained*, and the cylinder will tend to move in the direction of that pressure—that is, round its axis  $MN$ ; also, being *free* to move about that axis, it will continue to revolve round it in a direction opposite to the *efflux* as long as any fluid remains in the cylinders. If the other aperture be opened at the same time, it is evident that on the same principle, that aperture will tend to give motion to its branch of the horizontal cylinder in an opposite direction, or to the whole cylinder, in the same direction as the former. Thus a rapid and powerful motion will be given to the machine, and being made to communicate with a system of machinery, it may be applied, as the

moving principle, in mechanical operations of any required extent and variety.

This machine is said to be the most effective known for applying the power of a given *quantity* and a given *fall* of water to the working of machinery. Not only does it *apply* the *pressure* of the water arising from its height, but it applies it to the greatest possible advantage; for by lengthening the horizontal branch  $PP'$ , this pressure may be made to act at any required distance from the axis of motion; that is, the *leverage* of the pressure may be increased to any required extent. There is a still further advantage in this application of the force of a fall of water arising out of the centrifugal force produced in the fluid of the horizontal cylinder, by its revolution, which tends very greatly, and, indeed, almost without limit, to increase its pressure upon the sides of that cylinder, and, therefore, to increase the rotating power. So that by the lengthening of the horizontal arm not only is the *leverage* of the unsustained, or moving pressure increased, but that pressure itself is also increased. The only drawback upon these advantages consists in the expenditure of force required to give a rotatory motion to the continually *changing* mass of fluid in  $PP'$ .

It is a very remarkable fact, and one by no means creditable to those interested in works of Hydraulic Architecture, that this admirable machine, which is by no means a modern invention, should never, it would seem, yet have received a fair trial. Such a trial can, however, only be made on a scale of considerable magnitude, and under the direction of a person profoundly acquainted with the theoretical principles of Hydraulics. There can be little doubt that a trial thus conducted would establish the fact, which has been so continually asserted by those competent to judge of the theory of this instrument, that it is superior to any other for applying the force of a fall of water to the turning of machinery.

281. It matters not whether the pressure of a fluid upon the interior of a vessel which contains it be produced by its weight or by any other cause; so long as the *whole* surface of the vessel sustains that pressure, it will have no tendency to give motion to it; but if the pressure upon any portion of the surface be removed, by removing that portion of the surface of the vessel itself, the pressure on some corresponding opposite portion of the vessel becoming unsustained, a tendency to motion will be the result. Thus, if we were to take a vessel containing

a fluid which tends to expand itself\*, and, therefore, presses every where upon the sides of the vessel; so long as this vessel remained on all sides *closed*, this pressure of the fluid would have no tendency to communicate motion to it, being every where counteracted by some equal and opposite tendency. But if we make, any where, an aperture in the vessel, there will immediately be some opposite portion of it, the pressure upon which is unsustained; and there will ensue a tendency to motion in the direction of that pressure. Thus, if an aperture be made in the *under* part of the vessel, it will tend to ascend; and if the elasticity of the contained fluid be sufficiently great to produce the requisite pressure, the *weight*, of the vessel and of contained fluid, will be overcome, and the whole will ascend. as long as the pressure on the interior of the vessel continues. It is on this principle that rockets are made to ascend.

The combustible materials of a rocket are contained in a hollow cylindrical case usually made of paper, which when wet is partially closed at its extremity *A*, so as to leave there a narrow neck. This neck is bound tightly round with string, so as to preserve the contraction. When dry, this case is forced into a mould, in the bottom of which is fixed *vertically* a rod of metal *P Q*, which is of dimensions suited to the size of the rocket, and which enters at the narrow neck of which we have spoken, moulds that neck to the requisite form and dimensions, and then occupies a portion of the middle of the cylindrical case. The combustible materials of the rocket are then driven into the case from the top, with such force as to form them into a hard and almost solid mass. At the top of the case are placed the materials which are to be discharged when the rocket has completed its flight; the whole being then closed by the conical cap *B*, the rocket is drawn out of its mould, and there remains in its centre a hollow space *P Q*, of the dimensions of the rod which was forced through its neck.— A stick is then attached to the rocket, the object of which is to keep it in an upright position, and which is of great length, that its centre of gravity may be as low as possible, and thus the greatest possible *stability* given (Art. 294) to the upright position of the rocket. A light being then applied to the aperture



\* Fluids possessing this property are called elastic fluids. There is a great variety of them; the air we breathe is one.

P, the whole internal surface of the hollow cylinder P Q becomes ignited, a very great quantity of highly elastic and rarefied gas is produced, and a powerful pressure on the whole unoccupied space in the interior of the rocket, is the result. Were the aperture at P closed, this pressure would produce no tendency whatever to motion in the rocket, the pressure upon every portion of the internal surface being counteracted by some equal and opposite pressure; but this aperture being open, the pressure upwards on q is wholly unopposed, except by the weight of the rocket and stick; and if the proper dimensions be given to the parts of the rocket, and the charge be of sufficient strength, this pressure will be sufficient to overcome that weight, and cause the whole to ascend. The weights thus raised by the Congreve rockets are enormous. It is a distinctive characteristic of the rocket as compared with other projectiles, that it carries its impelling force with it. A bullet receives its impulse from the sudden expansion of the gases generated in the inflammation of the powder which constitutes the charge of the musket from which it was fired. The impulsive force, or force of motion thus communicated, may be wholly destroyed by the intervention of any sufficient obstacle; and this borrowed force once destroyed, the bullet will fall harmless to the ground, all power of motion being utterly extinct in it. Not so with the rocket. If it meet an obstacle sufficient to destroy its forward momentum, yet the principle of its motion still remains in it; and acquiring almost certainly an oblique direction by reason of the opposition presented to its forward motion, it will glance off in that oblique direction, and become again as formidable in that direction as before. Thus, too, a ball losing, in passing through any resisting body, a portion of its impelling force, will afterwards be comparatively ineffective; whereas a rocket quickly renews again any momentum which it may have lost. Rockets have thus been known to pass through whole files of men.

It is precisely upon the same principle that fire-works of another class are made to revolve on their axes.

## CHAPTER IV.

- 282 The Weight of a Floating Body equals the Weight of the Fluid it Displaces.
- 283 Its Centre of Gravity and that of the Part Immersed are in the same Vertical.
- 289 Equilibrium of a Triangular Prism.
- 290 Of a Pyramid.
- 291 Stability of Floating Bodies; Stable, Unstable, and Mixed Equilibrium.
- 295 Remarkable Analogy between Conditions of Equilibrium of a Floating Body and those of a Body supported on a Smooth Plane.

## ON THE CONDITIONS OF THE EQUILIBRIUM AND STABILITY OF FLOATING BODIES.

WE have shown, in the preceding chapter, that the horizontal pressure of a fluid, when at rest, does not produce any tendency whatever to motion in a body which is immersed in it, or in a vessel which contains it. We shall now show,

282. First, That the vertical pressure of the fluid upon a body partly or wholly immersed in it tends to raise the body with a force equal to the weight of a quantity of the fluid whose volume is equal to that of the portion of the mass immersed; or, in other words, with a force equal to the weight of the fluid which is *displaced*. Secondly, that the resultant of this excess of the upward over the downward pressure of the fluid upon the body *passes through the centre of gravity of the part immersed*.

To establish the first of these propositions, we have only to refer the reader to Art. 271. It is there shown that the *vertical* pressure upon any portion of the surface of a body immersed in a fluid, is equal to the weight of a column of the fluid immediately *superincumbent* to that portion of surface, and reaching to the surface of the fluid; also, that this is true wherever the surface may be situated; so that the pressure upon the surface  $PQ$ , in the accompanying figure, is the weight of the column  $PP''Q''Q$ ; and the pressure upon  $P'Q'$ , which has the same projection  $P''Q''$  with the other, the weight of the column  $P'P''Q''Q'$ . Now this is also true, whatever be the magnitudes of the surfaces  $PQ$  and  $P'Q'$ ; hence, therefore, increasing these so as to coincide with  $MPQN$  and  $MP'Q'N$ , it follows that the pressure upon the former equals the weight of the column  $MPQN''M''$ , and that upon the latter surface, the weight of the column  $MP'Q'N''M''$ . Now the difference of the weights of these two columns is, manifestly,

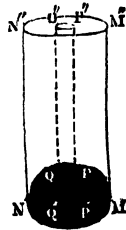



the weight of a mass of fluid equal to the whole solid immersed ; and the difference of these two weights is also the difference of the pressures of the fluid upon the surfaces  $MPQN$  and  $MP'Q'N$ , of which the former is downwards, and the latter upwards. Hence, therefore, it follows, that the upward pressure of a fluid upon the surface of a body immersed in it, exceeds the downward pressure by the weight of a quantity of the fluid of the same dimensions with the body. This surplus upward pressure tends to support its weight, and it is technically said to lose a portion of its weight equal to the weight of the quantity of fluid it displaces.

Not only, however, is this true when the body is *totally*, but also where it is only *partially* immersed. For it is evident, that if the surface of the fluid  $M'N'$ , instead of being wholly above the body, had intersected it, so that only a portion of the body had lain beneath it, then the weights of the columns  $M'MPQN$  and  $M'MP'Q'N$  would still have equalled the pressures upon it upwards and downwards, and their difference would also still have equalled the weight of that quantity of fluid which the body displaced ; so that *in all cases the excess of the upward over the downward pressure of the fluid upon a body wholly or partly immersed in it, equals THE WEIGHT OF THE FLUID DISPLACED.*

283. The second proposition stated above, at once follows from the consideration that the excess of the pressure upon  $PQ$  over that upon  $P'Q'$  is the weight of the column  $PP'Q'Q$ , and the same is true of all other corresponding elements of the surface ; hence, therefore, the resultant of all these excesses of pressure, that is of the *whole* excess of pressure, must equal the resultant of the weights of all the columns similar to  $PP'Q'Q$  ; which resultant manifestly passes through the centre of gravity of the whole mass, if it be *totally* immersed, or of the part of it immersed, if it be only partially immersed.

Hence, therefore, the resultant of the *effective* upward pressure of the fluid, or of the excess of its upward over its downward pressure, acts always through the centre of gravity of the part of the body immersed. Now the weight of the immersed body whose resultant acts also through its centre of gravity tends to counteract this upward pressure of the fluid ; and may be such as to be accurately in equilibrium with it. To this equilibrium the two following conditions are manifestly necessary.

First, that the weight of the body should equal the upward pressure of the fluid ; or, in other words, that it should equal the weight of the fluid which it displaces. Secondly, that the

resultant of the upward pressure of the fluid should have its direction in a direction opposite to the resultant of the weight of the body; or, in other words, that the vertical through the centre of gravity of the part of the body immersed should also pass through the centre of gravity of the body itself. When both these conditions are satisfied, the immersed body will be in equilibrium, and is said to *float*.

284. The last condition is *necessarily* satisfied whatever the form of the body may be, provided only it be *totally* immersed; for in this case the centre of gravity of the part immersed is the centre of gravity of the whole body; the resultant of the upward pressure necessarily acts, therefore, in a direction opposite to that of the weight, since one acts upwards, and the other downwards, and they both act through the same point, *viz.*, the centre of gravity of the mass. If, therefore, a body be *totally* immersed, the pressure of the fluid cannot produce in it any tendency to rotation; it may sink, or it may rise in the fluid, but it will not be made to turn round upon itself. If, however, it be allowed to rise to the surface, and a part of it emerge from the fluid, since the centre of gravity of the body and that of the part of it immersed no longer necessarily coincide, it *may*, and in all probability *will*, occur that the vertical through the latter does not pass through the former; thus the second condition of the equilibrium will cease to be satisfied; a fact which will at once become apparent in the rotation of the body. Hence, then, it appears, that whilst the body is *totally* immersed, *any* position is a position of equilibrium, provided only the *first* condition of equilibrium be satisfied; but that when the body is only *partially* immersed, there are certain positions in which alone the equilibrium is possible.

The principles stated above, explain a vast number of phenomena of common occurrence and of great practical importance.

285. If a body be totally immersed, and its weight be such as just to equal the weight of an equal bulk of the fluid, it will float in any position in which it is placed. If its weight be greater than that of an equal bulk of the fluid, it will sink to the bottom; and if it be less, it will ascend to the top of the fluid, and a portion of it will continue to *emerge* until that which remains immersed displaces just so much of the fluid as is equal to the weight of the body; turning, at the same time, round upon itself so as to adjust its position to the second condition stated above; *viz.*, that the vertical through the centre of gravity of the body should pass through that of the part of it immersed. Thus, it appears, that any body whose weight is

less than that of an equal bulk of the fluid, if immersed and left to itself, will at length find out for itself, on the surface of the fluid, a position in which it will rest, called its *position of equilibrium*.

286. If the material of which a mass is composed admit of being extended, so as to be formed into a vessel, whose external surface is of any given dimensions, however great, then it is apparent that any such mass may be made to *float*, however heavy it may be; for we may form it into a vessel whose surface is of such dimensions that it shall necessarily, before it can admit the fluid into its interior, displace a volume of that fluid, whose weight is greater than its own weight; its tendency to sink will then be counteracted, and it will float. Thus barges are not unfrequently made of iron, and a ship might be built of stone.

287. Of all possible geometrical forms, a sphere is that whose solidity being *given*, its *surface* is the *least*; or, in other words, wishing to form a body of a certain known volume, if we would form it so as to have the least possible surface which it can have, having that volume, we must make it a sphere. Now if we would form a floating body, which shall be just capable of supporting a *given* weight, we know that we must form it so as to displace a quantity of fluid, whose weight shall equal that given weight; also this quantity of fluid is equal to the solid *content* of the body. The solid content of the floating body is, therefore, in this case given; and it follows, that if we would form such a body with the least possible surface exposed to the action of the fluid, we must form it into a *sphere*.

288. The second condition of the equilibrium of a floating body; *viz.*, "that its centre of gravity, and that of the part of it immersed, should be in the same vertical line," is necessarily satisfied, however much of the body be immersed, provided it be symmetrical about a certain line, and be immersed with that line in a vertical direction. For being thus immersed, the *part* of it immersed will be symmetrical about the axis of which we have spoken, as well as the whole body. Now (Art. 61), the centre of gravity of a body, symmetrical about a given line or axis, is necessarily in that line or axis. Hence, therefore, it follows that the centre of gravity of the body, and of the part of it immersed, are both in the axis of which we have spoken, and therefore both in the same *vertical*. Thus, a cylinder immersed with its axis vertical, will have the second condition satisfied to however great a depth it be sunk, since the centre of gravity of the part of it immersed (being that of a portion of the cylinder

formed by cutting it across transversely, or perpendicular to its axis) is also itself in the axis of the cylinder. Thus, too, a sphere being immersed in a fluid, the second condition of equilibrium will be satisfied to whatever depth, and in whatever position, it is immersed, since a sphere is symmetrical about *any* diameter, and in whatever position it is immersed, one of these diameters must be vertical. If a body be prismatic, that is, if its sides be straight, and it be such that all sections made across it, perpendicular to its sides, are similar and equal; then it is clear that there is a certain line parallel to these sides, in which are the centres of gravity of all the parts which can be cut off from it by such sections as we have spoken of. Provided, then, the body be immersed with this line or axis vertical, the centre of gravity of the part immersed will always be in it, and also the centre of gravity of the body itself, to whatever depth it be sunk. The body represented in the following figure is one of this class. Its centre of gravity, and that of *any* portion cut off from it *across*, or in a direction perpendicular to its sides, will manifestly be in the line  $OX$ , which is parallel to its sides. If, therefore, the body be immersed with this line, or with its sides, vertical, the second condition of equilibrium will be satisfied. If, however, instead of immersing the body vertically, we immerse it with its sides in an oblique position, this will be no longer the case, and we must have recourse to the

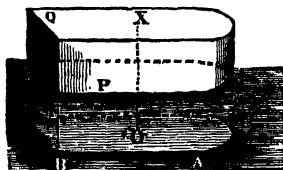

#### GENERAL CONDITIONS OF THE EQUILIBRIUM AND STABILITY OF FLOATING BODIES.

BEFORE, however, we proceed to discuss these, let us take two particular cases, which will serve, perhaps, to put in a clearer light the principles we have stated above.

289. Let us first of all imagine a solid body in the form of a triangular wedge, to be immersed in a fluid, with one of its angles downwards. It is evident that the conditions of the equilibrium of this body will be precisely the same, whatever be its length; and therefore they will be the same as those of a very narrow section or lamina of it.

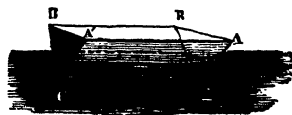

Let  $ABC$ , (fig. 1,) represent one of these sections. Take  $G$

its centre of gravity. This point is evidently (Art. 68) in the line  $cD$ , joining the point  $c$  with a bisection  $D$  of the base ;

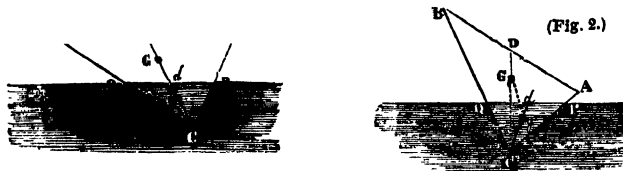

the distance  $cG$  being equal to two-thirds of  $cD$ . Suppose the triangle to be so immersed that  $AB$  may be horizontal, and let  $PCQ$  be the part of it immersed ; the plane  $PQ$  is then called the *plane of flotation*. Since  $PQ$  is parallel to  $AB$ , therefore  $CD$  bisects  $PQ$  in  $d$ , as well as  $AB$  in  $D$ . Hence therefore, the centre of gravity of the triangle  $PCQ$  is in  $cd$ , at a point  $g$  distant from  $c$  by two-thirds of  $cd$ . Since, then, the points  $G$  and  $g$  are both in the line  $CD$ , and that these are the centres of gravity of the body, and the part of it immersed ; it is necessary to the equilibrium by the second condition, that the line  $CD$  be itself *vertical*. But  $AB$  is horizontal by supposition,  $CD$  must, therefore, be perpendicular to  $AB$ . But since  $CD$  bisects  $AB$ , it cannot be perpendicular, also, to that line, unless the triangle be isosceles, or have its two sides,  $CA$  and  $CB$ , equal. Hence, therefore, it appears that the triangle cannot, under any other circumstances, rest with its base in a horizontal position.

Suppose  $ABC$ , (fig. 2,) to represent a triangle partially immersed in any given position ;  $PCQ$  being the *part immersed*. Bisect  $AB$  in  $D$  and  $PQ$  in  $d$  ; join  $CD$  and  $cd$ , and take  $cG$  equal to two-thirds of  $CD$ , and  $cg$  equal to two-thirds of  $cd$  ; then  $G$  and  $g$  are the centres of gravity of the triangle, and the part of it immersed. Join  $Gg$ , then, in order that there may be an equilibrium, this line  $Gg$  must be vertical ; that is, it must be perpendicular to  $PQ$ , which being a continuation of the *surface* of the fluid, is necessarily horizontal. This is the *second* condition of the equilibrium. The first is, that the weight of the fluid displaced by the part immersed,  $PCQ$ , should equal the weight of the whole triangle. These two conditions are sufficient to determine geometrically what must be the position of the triangle\*.

\* For a theoretical discussion of the conditions of the equilibrium of a floating body, the section of the immersed portion of which is a triangle or a rectangular parallelogram ; the reader is referred to a treatise on Hydrostatics and Hydrodynamics, by the author of this work, pp. 67, 78.

290. Again, let us take the case of a pyramid immersed in a fluid with its vertex downwards. Take  $E$  the centre of gravity of its base, and join  $AE$ ; and take  $AG$  equal to three-fourths of  $AE$ ; then will  $G$  be the centre of gravity of the pyramid. Let  $APQR$  be the part of the pyramid immersed, and  $e$  the centre of gravity of its base. Join  $Ae$ , and take  $Ag$  equal to three-fourths of  $Ae$ ; then will  $g$  be the centre of gravity of the part immersed. It is necessary to the equilibrium that  $G$  and  $g$  be in the same vertical line. If, therefore  $G$  and  $g$  be joined by the straight line  $Gg$ ; when the body is in a position of equilibrium, this line must be vertical. But  $PRQ$  is horizontal, being the plane of flotation,  $Gg$  must, therefore, be perpendicular to  $PRQ$ . This condition, coupled with the *first* condition of equilibrium, namely, that the weight of the fluid displaced by  $APQR$  should equal the whole weight of the pyramid, is sufficient to determine, by known rules of geometry, the exact position of the pyramid.

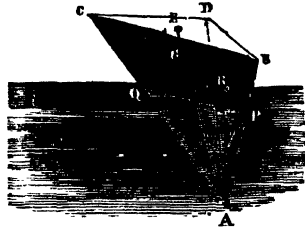

## ON THE STABILITY OF FLOATING BODIES.

291. Let either of the figures beneath, represent a body partially immersed in a fluid. Let  $G$  be its centre of gravity, and  $g$  that of the part of it immersed;  $PQ$  the section of it, which would be made by the surface of the fluid is there continued through it, and called the plane of flotation. Suppose the body to be turned about its centre of gravity  $G$ , continually in the direction indicated by the curved arrows; and let it at the

(Fig. 1.)

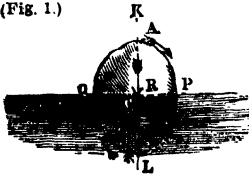

(Fig. 2.)



same time be moved upwards and downwards in the vertical  $KL$ , which passes through  $G$ , so as to satisfy, in all its positions, the first condition of equilibrium, namely, that its weight shall be equalled by that of the fluid it displaces. Suppose further this revolution to have been commenced when the body was in a position of equilibrium, and when the point  $g$  was, therefore,

*in* the vertical  $\kappa L$ . When the body begins to revolve out of this position, the point  $g$  will, of course, move out of the vertical. Now if, as in fig. 1, its motion be *towards* the direction in which the body is revolving, it is clear that there will be a tendency in the body to *continue* its revolution in the direction in which it has already been made to revolve, that is, *from* its position of equilibrium; for the whole of the weight of the body may be supposed to act *downwards* at  $g$ , and the whole pressure of the fluid *upwards* at  $g$ : and these are the only forces which act upon the body; now, subjected to the action of these two forces, the body would clearly be made to revolve in the direction towards which it has already begun to revolve; that is, *from* its position of equilibrium; that position is, therefore, one of *unstable* equilibrium.

Now let us suppose the revolution of the body to be continued in the same direction as before. The point  $g$  will continue for a certain time to move from the vertical, in the direction of the revolution, the *greater* portion of the part immersed lying on that side of the vertical; but, by degrees, this will begin to be exchanged for the lesser portion, from the other side the vertical; the parts  $LRQ$  and  $LRP^*$  will begin to approach more nearly to an equality, and the point  $g$  will then *approach* the vertical again, describing a curve indicated by the dark line. At length  $g$  will be found again *in* the vertical, and the centre of gravity of the body being in the same vertical, the second condition of equilibrium will again be satisfied. Also the first condition is supposed to be satisfied in every position of the body. We have, therefore, a second position of equilibrium. Let the revolution of the body now be still further continued in the same direction as before. The point  $g$  will now either *cross* the vertical, continuing to move in the direction in which it was *last* moving, or it will *return*, receding again from the vertical as at *first*. If it *cross* the vertical, it will lie on the opposite side of it to that towards which the body is moving, as shown in fig. 2, and this being the case, if we consider that the weight of the body, and the upward pressure of the fluid act as though they were collected in  $g$  and  $g$ , we shall perceive that their tendency is *now* to cause a motion in the body towards the opposite direction to that in which it is moving,

\* This will, perhaps, be better understood by a reference to the next figure, where the body is shown in one of its *oblique* positions. The position of  $g$ , with respect to the vertical, manifestly depends upon the relative magnitudes and positions of the parts  $LRP$  and  $LRQ$ ; it necessarily lies towards the greater, and the more distant of these parts.

or *towards* its last position of equilibrium. Here, therefore, the equilibrium is *stable*. If, according to our other supposition, the point  $g$  does not *cross* the vertical, the curve described by that point not *cutting*, but *touching* it, then the tendency of the body is still to revolve towards the direction in which it has hitherto been revolving. If we move it, however, from this position slightly *backwards*, it will still tend to move in the same direction as before, that is, *opposite* to its *last* motion. Under these circumstances, therefore, the position of equilibrium possesses these remarkable properties, that move it out of that position in one direction, and it tends to recede from it; move it in the other, and it tends to return to it. The position is, in this case, said to be one of mixed equilibrium. From the above, then, it appears, that turning the body continually round in any given direction, and causing it in every position to satisfy the first condition of equilibrium, we shall find that if no position of *mixed* equilibrium intervene, its positions will be alternately *stable* and *unstable*. Also, that this law of the alternation of the positions obtains, leaving out the positions of mixed equilibrium, if any such occur.

292. It is clear, from what has been said above, and from an inspection of the figures, that the character of the stability of any position of equilibrium, is determined by the direction of the motion of the centre of gravity  $g$  of the part immersed, when the body is made to revolve out of that position. If the point  $g$  move *towards* the direction of the revolution, the equilibrium is *unstable*, if it move *from* it, it is *stable*; the gravity of the body, and the upward pressure of the fluid tending, in the first case, to *continue* the revolution, and in the other to *counteract*, and ultimately to destroy it.

293. Let the accompanying figure represent any oblique position, into which the body has been moved out of a position of equilibrium, and let  $AB$  represent what *was* the direction of the vertical through the centre of gravity  $G$  of the body, when it was in that position, and  $KL$  the present direction of that vertical; these lines intersect, therefore, in  $g$ , the centre of gravity of the body; and from what has been said before, it follows that the equilibrium is *stable* or *unstable* according as the motion of the centre of gravity  $g$  of the part immersed has been *from* the direction of the revolution of the body or *towards* it; that is as  $g$  lies on the side of  $r$ , from the





vertical  $\kappa L$ , or on the side of  $q$ . Draw through  $g$  the vertical  $g c$  intersecting  $AB$  in  $c$ . It is clear that  $g$  lies from  $\kappa L$  towards  $P$ , or towards  $q$ , according as  $c$  is above or below  $g$ . If, therefore,  $c$  be above  $g$  (Art. 292,) the equilibrium is *stable*. If it be below  $g$  it is *unstable*. And this is true however small the angle  $g c B$  through which the body has been made to revolve may be. If this angle be the least possible, so that  $c$  may be the *first* intersection of the vertical through  $g$ , when the body is moved out of its position of equilibrium, with  $AB$ , then  $c$  is called the *metacentre*. The position of this *metacentre*, in reference to any position of equilibrium, may be determined by known rules of geometry. And it is thus ascertained, curiously enough, to be wholly independent of the *form* of the part of the body immersed; and to depend wholly upon the form and dimensions of its *plane of flotation*  $PQ$  and the *volume* of the part immersed. This connexion between the position of the *metacentre* and the form and magnitude of the plane of flotation will be explained in Article 295. The determination of the position of the metacentre is absolutely necessary to a knowledge of the conditions and character of the stability of a floating body.

294. Not only, however, does it inform us whether the character of the equilibrium be stable or unstable, but further we learn from it the *degree* of the body's stability; whether it resist any force, tending to deflect it from its vertical position, with a greater or less degree of force. To show this let  $p$  be the force necessary to deflect the body into the position represented in the figure, and let it act at  $A$ , in the direction represented by the arrow. Take  $g$  for the point about which the moments are measured, draw  $g m$  perpendicular to  $g c$ , and let  $GA$  be supposed perpendicular to  $p$ . Then, since the system is supposed in equilibrium, we have, by the principle of the equality of moments, (Art. 36.)

$$p \times GA = (\text{upward pressure of fluid at } g) \times gm.$$

Now the upward pressure of the fluid at  $g$  equals the weight of the fluid displaced, that is, it equals the weight of the body (Art. 283.) Hence, therefore, if we can conceive a number of different floating bodies to be all of them inclined, as represented in the figure, the weights of all being the same, and also the distances at which the disturbing forces  $p$  are applied; it follows, that, since an equality of moments, similar to the above, must obtain in all the cases, where  $gm$  is *greatest* there  $p$  must be the *greatest*. The magnitude of the force necessary to produce the disturbance depends, therefore, upon the magnitude of  $gm$ .

Now, if all the bodies be inclined at the same angle, the magnitude of  $gm$  is manifestly greater as  $gc$  is greater. The greater, therefore, is the distance  $gc$ , of its *metacentre* above its centre of gravity, the greater force is there required to move a floating body of a given weight through a given angle. The greater, therefore, is the stability of the body. There can be no question that very many vessels have been lost through a neglect of this most important principle in the theory of their construction. To be safe, it is clear that every vessel should be so constructed that when carrying a certain known quantity of lading and ballast, and for this reason sinking to a given and observed depth in the water, her metacentre should be so high above her centre of gravity that the force of the winds, when acting upon her mast and rigging with their greatest known velocity, should not be sufficient to incline her beyond a certain given angle. It is also quite apparent that a vessel might be constructed according to these conditions.

Before the principles stated above were known to naval architects, vessels were not unfrequently found after their construction to be of unstable equilibrium; except, perhaps, when heavily laden, so as to bring the point  $g$  to its greatest possible depth. Others again, although their equilibrium appeared stable under the slight derangement to which their position was subjected in port; yet when they came to be deflected by the wind, were found to have their true position of stable equilibrium on one side. Others again wholly upset\*. Science has now taught men to protect themselves against these evils. The secret of the metacentre no experience or observation could *ever* have developed; it was a discovery reserved for the systematic investigations of the mathematician.

295. There is another view of this important question of the stability of floating bodies which as it is not generally known, is in some respects new, and leads directly to results of great practical value; we now proceed to lay it before our readers. Let us imagine an infinite number of planes to be taken, cutting off, all of them, an equal volume from the mass  $A B$ ; also let this volume equal that of a quantity of water whose weight is the same with that of the mass  $A B$ . Let the centres

\* Vessels laden with sugar, and taking in water in rough weather, have been lost by the solution of the sugar, then pumped away with the water. The weight of the lading, and the position of the plane of flotation, the centre of gravity and the metacentre, have been so altered, as to make the equilibrium *unstable*. It is to *govern* the relative positions of the centre of gravity and the metacentre, that the vessel takes in ballast.



of gravity of all the parts cut off by these planes be taken. These centres of gravity (infinite in number,) will all lie in a certain surface, which suppose to be represented by  $GG'$ . Let  $PQ$  be any one of the planes spoken of above; then if the portion  $PBQ$  of the body be immersed the first condition of equilibrium will be satisfied.

Let  $g$  be the centre of gravity of  $PBQ$ ,  $g$  is then in the surface  $GG'$ . Also it may be shown\* that the tangent plane to that surface at  $g$  is parallel to the plane  $PQ$ . Now  $PQ$  is the plane of flotation, when the portion  $PBQ$  of the body is immersed;  $PQ$  is, therefore, horizontal, and the tangent to the surface  $GG'$  at  $g$  is horizontal. Now the pressure of the fluid acting at that point upwards is *vertical*. It is, therefore, *perpendicular* to the surface  $GG'$  at  $g$ . Its effect is, therefore, precisely the same as though the surface  $GG'$  rested upon a perfectly smooth horizontal plane at  $g$ . And the same is true of every other of the body's positions, and of every other point in the surface  $GG'$ . In each of its positions the effect of the forces acting upon the body is, therefore, the same as though its weight were collected in its centre of gravity and it were supported upon a horizontal plane by the intervention of the surface  $GG'$ . The conditions of the equilibrium and stability of a floating body reduce themselves, then, to those of a solid body supported on a horizontal plane by means of the surface  $GG'$ ; and it follows that there are as many positions of equilibrium as can be drawn perpendiculars from the centre of gravity of the body upon that surface. Also that these (Art. 223) are *stable* or *unstable*, according as the centre of gravity of the body is in those positions below or above the centre of curvature of the surface  $GG'$ , at the point of that surface in which the centre of gravity of the part immersed is then found. This centre of curvature of  $GG'$  is the metacentre.

Since the plane of flotation  $PQ$  is parallel to the tangent to the surface  $GG'$  in  $g$ ; and this is true for every other plane of flotation and corresponding position of  $g$ ; it is apparent that the surface which is *touched* by all the planes of flotation, is similar to the surface  $GG'$  and only differs from it in magnitude. Hence we can readily understand how the position of the centre of curvature at any point  $g$  of  $GG'$  should be dependent upon the form and dimensions of the plane of flotation.

\* The proof of this property is given in the Appendix.

## CHAPTER V.

- |  |  |
|--|--|
| 296 Specific Gravity.—the Unit of                                  | 303 Method of finding the Specific Gravity of Fluids.    |
| 300 General Rule for determining the Specific Gravities of Bodies. | 304 The Hydrometer.                                      |
| 301 Method of finding the Specific Gravities of Solid Bodies.      | 305 Sikes' Hydrometer.                                   |
| 302 The Hydrostatic Balance.                                       | 306 The Areometer.                                       |
|  | 307 Fahrenheit's Hydrometer.                             |
|  | 308 Nicholson's Hydrometer.—Table of Specific Gravities. |

## SPECIFIC GRAVITY.

296. THAT force which exists in all matter fixed there *eternally* and *inseparably*, under the name of gravity or weight, is not distributed so through it, as that each portion of equal dimensions or volume should contain the *same amount* or *quantity of it*. Nature presents us, in this respect, with an infinite variety, there being an infinity of substances of which equal bulks or volumes being taken, these are found to have different weights. Thus a cubical inch of iron and a cubical inch of gold, would be found to weigh differently. So of a cubical inch of water and the same volume of alcohol. This difference of weight under the same volume constitutes one of those sensible properties by which substances are principally distinguished from one another, as of different kinds or of the same kind; and it forms a most important element in the conditions of their equilibrium. The term weight, as used in common conversation, has two very different meanings; we speak sometimes of the weight of a body or portion of matter, meaning merely the whole force with which that body or portion of matter tends to the centre of the earth. We speak at other times of its weight, meaning thereby the quantity of such force in each equal portion of it. In the former sense, we speak of the weight of a certain known mass of any substance, as a piece of iron, for instance. In the latter sense, we use no term describing the magnitude, or fixing the identity of the substance spoken of, we say, *the weight of iron*. In the first case, we mean the precise number of units of weight in the whole body of which we speak. In the other case, we mean the number of units of weight in a *certain known volume* of the mass, a cubical inch for instance, or a cubical foot. It is in this sense, that in speaking of a mass of lead and a mass of iron placed in opposite scale-pans of a balance, and in equilibrium with one another, we should say, that this lead is of equal weight with that iron, nevertheless, lead is heavier than iron: the whole mass of the lead contains as many units of weight as the whole mass of the iron; nevertheless, a cubical

inch, or cubical foot of lead contains *more* units of weight than a cubical inch or cubical foot of iron. In the common intercourse of life these different ideas are made to attach themselves to the same word without any great practical inconvenience. The language of science requires, however, greater precision. We therefore confine the term weight or gravity, to its first sense; and speaking scientifically of the weight or gravity of any body or substance, we mean the number of units of weight contained in the whole of that body or substance.

297. In its *second* sense, namely, that in which it implies the weight or gravity of a given volume or portion of the substance, we apply to it the term *specific gravity*. The specific gravity of a substance is, therefore, the number of units of weight contained in a certain known *volume* or *bulk* of it; which known *volume* or *bulk* is usually taken to be one unit of the whole volume or bulk. The units of weight used in measuring the *specific gravity* of a body, are not the same with those used in determining its ordinary weight. Thus we do not say, that the specific gravity of a body is so many pounds in the cubical foot or inch, meaning by the term, one pound, the weight of a certain quantity of water determined as explained (Art. 12.) But to measure the *specific gravity* of a body we always take for our unit of weight, the weight of a quantity of water of the same volume with one unit of the volume of the body, whatever that unit may be. Thus, if the volume is measured in cubic inches, the unit of weight used in fixing its specific gravity, is the weight of one cubical inch of water. And the specific gravity of the body is in point of fact, no other than the number of cubical inches of water equal in weight to one of *its* cubical inches. So if the body be measured in cubical feet, its specific gravity is the number of cubical feet of water whose weight shall equal one of *its* cubical feet. Thus in the table of Specific Gravities which will be found at the end of this chapter, the number 8·900, stated as the specific gravity of Copper, *means* that each cubical inch or cubical foot of copper weighs the same with 8·900 cubical inches or cubical feet of water. Thus knowing the number of cubical feet in a body, and knowing its specific gravity, we can tell how much water it is equal in weight to, by multiplying this specific gravity by the number of cubical feet—this specific gravity being in fact, the number of cubical feet of water equal in weight to each cubical foot.

298. The unit of weight used in determining the specific gravities of bodies being the weight of an unit of volume of water, that unit of volume of water is of course supposed to

have always the same weight. It is, therefore, supposed to be free from all impurities, which would subject its weight to variation. Thus the specific gravity of a body determined by means of water taken out of the *Thames* would differ from the specific gravity of the *same* body taken by means of water from the *Severn*. And both waters being impure, neither would give the true specific gravity—the impurities increasing the weight of one unit of the volume of the water in both cases. Again, the bulk of the water varies with its temperature, so that there is not so much water, or so great a weight of water in an unit of volume at one temperature as at another, and thus the variation of temperature may produce a variation in the standard unit. To remove these causes of error, the water is supposed to be cleared of all its impurities by distillation. And to be brought at all times to the same temperature, namely, 62° Fahrenheit. At this temperature one cubic inch of it weighs, according to Captain Kater, 252,458 grains. Knowing then the volume and *specific* gravity of a body, we can tell its *actual* weight or gravity. Multiplying its volume in cubical inches by its specific gravity, we shall get the number of cubic inches of water of equal weight with it; and multiplying this again by 252,458, we shall get its actual weight in grains. At the end of this chapter will be found a table of the specific gravities of a great variety of different substances, determined by methods which we are now about to explain.

#### METHODS OF DETERMINING THE SPECIFIC GRAVITIES OF SOLID BODIES.

299. WE know that if a solid body be immersed in a fluid, the *upward* pressure of the fluid will just equal the weight of the fluid which is displaced by the solid, and which is therefore precisely of the same volume with it. Hence, therefore, the *downward* pressure or weight of a body immersed in a fluid, will be diminished by the weight of a volume of water precisely equal to its own volume. If, then, we ascertain how much the downward pressure or weight of the body is diminished by its immersion, we shall know what is the weight of the same volume of water. Now, dividing the *actual weight* of the body out of the water by *this* weight, the result will be the specific gravity required. For the specific gravity is the number of times one unit of volume of the water must be repeated, to equal in weight an unit of the body; and therefore it is equal to the number of times any given number of units of the water must be taken to equal the same number

of units of the body ; and therefore, to the number of times any given bulk of water must be taken to equal in weight the same bulk of the body.

300. Now, if we divide the whole weight of the body by the weight of an equal bulk of water, we manifestly get the number of times that the latter is contained in the former ; that is, we get the specific gravity.

301. For determining the weight lost by the body in its immersion, the following is a simple method\*. In one scale of

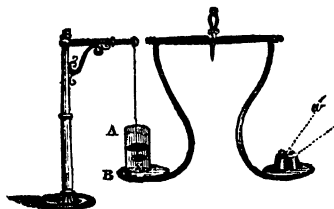

a balance let there be placed a vessel of distilled water *AB*, and let such a weight *w* be placed in the other scale-pan as will just produce an equilibrium. Let the solid whose specific gravity is to be determined be suspended by a fine wire or thread, or a hair from a stand represented in the figure, so as

to admit of being made to descend into the vessel of water ; and it will be better if there be introduced some mechanical contrivance for giving it a gradual descent. Immediately that the immersion has commenced, the equilibrium of the balance will be perceived to be destroyed. The scale-pan containing the vessel of fluid will preponderate. Let such a weight *w'* be placed in the other scale-pan as will just restore the equilibrium when the body is totally immersed.

The weight *w'* is that lost by the body in its immersion, and is equal to the weight of the fluid it displaces ; for by the immersion of the body, the tension upon the string—which is just that necessary to support the body—is diminished by the weight of the fluid it displaces. Now, the downward pressure of the body is equal to its whole weight : of which the string supports a quantity less than this by the weight of the fluid displaced ; the fluid itself supports, therefore, the remainder, and its pressure downwards is increased by the weight

\* This method, although readily applied, is not an accurate one. The sensibility of a balance is always less as it is more heavily loaded. In this case, the balance is laden with the weight of the vessel and its contained liquid, in addition to that of the body. In the methods afterwards to be described, it is the body *only* which is placed in it. It is, moreover, a customary, and a very necessary precaution, to boil the body whose specific gravity is to be determined in the water to be used, to drive off the obstinately adhering bubbles of air. This precaution could not, in this case, be taken, by reason of the loss by evaporation.

of the fluid displaced. Thus the equilibrium cannot be preserved, except by putting into the opposite scale-pan a weight equal to that of the fluid displaced. We may verify this fact very readily, by placing in the opposite scale-pan, instead of  $w$ , another vessel, precisely of the same dimension with  $A B$ , and pouring fluid into it until there is an equilibrium. Marking the height at which the fluid stands in both vessels, then immersing the body in  $A B$  as before, and pouring fluid into the other vessel, so as to preserve the equilibrium—we shall find that the fluid so poured in, will cause the surface of the fluid to rise in the one vessel by precisely the same quantity that the immersion has caused it to rise in the other. The quantity of the fluid displaced is, therefore, precisely equal to the quantity of fluid whose weight equals the weight lost by immersion.

## THE HYDROSTATIC BALANCE.

302. IF a body, having been weighed in the scale of a balance, be then suspended by a fine thread beneath it ; and, thus suspended, if it be allowed to descend into a vessel of water placed beneath it, when completely immersed it will be buoyed up with a force equal to the weight of a mass of water of the same bulk with itself. A less weight in the opposite scale-pan will now, then, be required to balance it—less by precisely the weight of this bulk of water. Thus, then, by observing what is the difference of the weights necessary to balance it, now that it is immersed, and before ; or what weight it has lost by immersion—we know what is the weight of a quantity of water exactly of the same bulk with it. Dividing the weight of the body by *this* weight, we have the specific gravity. The balance used for thus determining the specific gravities of bodies, is called the Hydrostatic Balance. It is simply a balance of great delicacy, one of whose scales may be removed when it is thus to be used, and replaced by a scale-pan suspended from shorter strings, and to the bottom of which

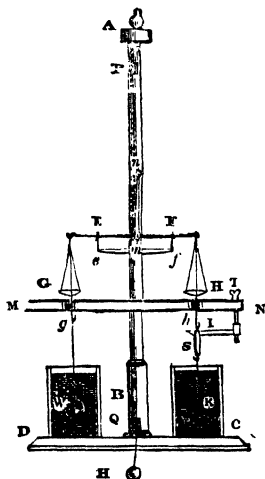



is fixed a hook, from which is suspended by a hair the body whose specific gravity is to be determined.

It is evidently necessary that we suspend the body  $w$  by means of some very slender substance ; otherwise allowance must be made for the quantity of that substance immersed. When, however,  $g w$  is exceedingly slender (a human hair, for instance), it becomes incapable of sustaining a mass of any but very small dimensions. To remedy this inconvenience, we may suspend *with* it a glass bubble, the weight and quantity of water displaced by which, has been before accurately ascertained. This glass bubble will help to support the body, and thus diminish the tension upon the hair. Proceeding precisely as before, we may ascertain the weight of the compound body, made up of the substance under examination and the bubble, and the weight which it loses by immersion, if we then deduct from the first of these the weight of the bubble, and from the second the weight of the fluid it displaces, we shall obtain the weight of the body and the weight of the fluid *it* displaces, and dividing one of these results by the other, we shall have, as before, the specific gravity. (Art. 300.) The bubble must not of course be so large as to prevent the body from sinking. If the body be specifically lighter than water, so that it will not sink in it ; then instead of attaching it to a bubble, so as to support it, we must attach it to a *weight*, which will sink it, having first ascertained the number of grains in the weight, and the weight of the water it displaces ; proceeding then precisely as in the last case we shall determine accurately the specific gravity of the body.

If the substance whose specific gravity is to be determined, be composed of small detached pieces, we may suspend a metal dish from the scale  $G$ , and having first ascertained, as before, the weight of the dish, and the weight of water displaced by it ; we may then place in it any number of pieces of the substance under examination, ascertain the weight of the whole, and the weight *lost* by its immersion, and then proceed as before. If the substance be in its nature soluble in water, we may determine its specific gravity, by ascertaining the weight which it loses when immersed in alcohol, oil, or some other liquid in which it is *not* soluble. Knowing the specific gravity of *this liquid*, we can then tell what is the weight of an equal bulk of water to that portion of the liquid which it displaces. This weight of an *equal* bulk of water, divided by the weight of the body, is the specific gravity required.

Substances of the same kind are found to have the same

specific gravity, whatever portions of them we submit to examination\*. Thus every portion of pure cast gold placed in the Hydrostatic Balance, will be found to have the specific gravity 19·25, and every portion of copper, 8·900. But if the substance be compounded with any other, then the specific gravity of the compound will differ from that of either of the component parts; the quantity of water it displaces being not the same with the quantity which would be displaced by the same weight of either of those parts. Hence, it follows, that we may tell by the Hydrostatic Balance, whether any substance be alloyed or not, provided we know what ought to be its specific gravity. This is a most useful method of determining whether metals be alloyed or pure; we may even thus ascertain pretty nearly what is the proportion of the alloy!

It is told of Hiero, king of Syracuse, that having a crown made for him, into the gold of which he suspected the maker to have put some alloy, he referred the question to Archimedes. The philosopher, as he one day lay in his bath, and considered the nature of the support which the fluid gave to his body, taking away from it apparently a considerable portion of its weight, was struck with the idea that this supporting force must just equal the weight of the water which would have run over the edges of the bath, if it had been full when he got into it; that is, that it must equal the weight of the water displaced by his body. This idea constitutes the first and great secret of the theory of floating bodies. The powerful mind of the philosopher carried him at once through the train of reasoning which we have been labouring to develop through this chapter of our work, its connexion with the question of the crown occurred to him; and he rushed naked from the bath, exclaiming, *Εύρηκα! Εύρηκα!* *I have found it! I have found it!* Archimedes is the discoverer and founder of the theory of floating bodies; the fundamental and, practically, the most important branch, of the theory of Hydrostatics. He has expounded that theory with wonderful accuracy and power in his treatise, entitled "*De humido insidentibus.*" The theory of the Lever owes also its origin to Archimedes, and this theory stands in the same relation to Statics, that the theory of floating bodies does to Hydrostatics. We thus owe to that admirable philosopher the most important and valuable of our knowledge in the two fundamental branches of Physics.

\* This is the general rule; it holds accurately under the same circumstances of temperature with regard to by far the greater number of bodies.

### ON THE METHODS OF DETERMINING THE SPECIFIC GRAVITIES OF FLUIDS.

303. LET a vessel be weighed and then filled with distilled water, and weighed a second time. The weight of the *water* it will contain, will then be known. Let it now be filled with the fluid whose specific gravity is to be determined, and weighed again. The weight of the quantity of the fluid it will contain, will then be known. We shall know thus, the weight of the water the vessel will contain, and the weight of the fluid it will contain; that is, we shall know the weights of *equal volumes* of the fluid and water; dividing these weights, therefore, by one another, we shall know its specific gravity. (Art. 300.)

There is a very ingenious instrument, whose application to the determination of the specific gravities of liquids is even easier and simpler than the method described above; it is called

#### THE HYDROMETER.

304. THE principle of this instrument may be explained as follows. A body when it floats at rest in a fluid, has been shown to displace such a quantity of that fluid, as shall have the same *weight* with itself. If, therefore, the *same* body be made to float in different fluids, the quantities of these fluids which it displaces when it floats at rest, will depend on their specific weights or gravities. It must displace more of the *lighter* fluid to float upon it, than of the *heavier*. It must, therefore, sink deeper in the lighter fluid than the heavier.

Thus to every fluid of a different specific gravity, there corresponds a different depth to which the same body will sink, before it float in it. Now the specific gravities corresponding to all these different depths of immersion may readily enough be calculated by formulæ which it does not consist with the elementary character of this work to explain.

Any number of different depths of immersion being therefore marked as divisions upon the side of the body, and the specific gravity corresponding to each, being ascertained by the proper formulæ, and annexed to its division or registered in an accompanying table, we may, by placing the body in any fluid and observing to what division it sinks before it finally rests, and then referring to the table, accurately determine the specific gravity of the fluid.

305. Sikes' Hydrometer—which is that ordered, by Act of Parliament, to be used in collecting the revenue upon ardent

spirits, is an instrument of this class. It is represented in the accompanying figure. A is a hollow sphere of brass, F B and C D are two stems fixed in it in the direction of one of its diameters produced both ways. B F is of a conical form, being thicker towards its lower than its upper extremity. It is about one inch and an eighth long. B is a bulb which is loaded so as to be much heavier than an equal volume of any other portion of the instrument. The object of this loading is to bring the centre of gravity of the instrument as low as possible, so that it may be as far as possible beneath the *metacentre* (see Art. 294), and thus the instrument may have the greatest possible stability. The use of the ball A is to cause the body to displace such a quantity of fluid, that in the lightest fluid in which it is to be used, the weight of that quantity of fluid may, when it is totally immersed, at least equal its own weight; the fluid in that case just reaching the top c of the stem c d. This stem is of brass; it is flat, of uniform thickness and width, and is three inches and four-tenths in length. It is divided on both sides into eleven equal parts, each of which is subdivided into two.

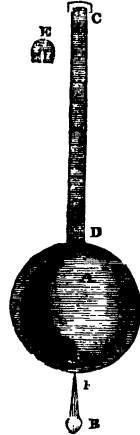

The instrument is plunged into the fluid whose specific gravity is to be determined by it, until it is wetted to the highest degree of the scale; it is then left to itself, until at length it rests in its position of equilibrium. The division of the scale which is intersected by the surface of the fluid is then observed, and by reference to the table, the specific gravity corresponding to that division at once becomes known. A correction is required for the temperature, for the application of which, rules are given accompanying the tables. Eight circular weights, of which one is represented at E, accompany the instrument. In each of these is a slit terminated by a circular aperture. Through this slit they may be made to slide upon the stem c d at its thinner extremity, they then fall down to the thicker end, and become fixed there, that extremity being too wide to slide through the slit.

The use of these weights is to adapt the instrument for use in fluids whose specific gravity is so great, that it would not sink in them, to the level of the *lowest* division on the stem c d without

being thus loaded. Of course a different table of specific gravities is required for each different loading of the instrument.

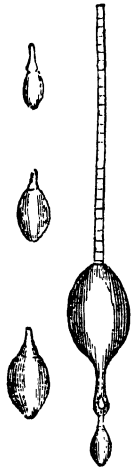

The accompanying cut represents an improved form of Sikes' Hydrometer, as constructed by Mr. Bate, and recommended in a report of the Excise Committee in 1836. The stem is four inches in length, and contains 900 divisions, *which are so made as to correspond successively to equally-increasing specific gravities.* There are eight poises, or detached weights, of which some are shown in the figure, and which fix in a stirrup at the bottom of the instrument. These poises are so adjusted as to sink the instrument to its last division successively, when immersed in fluids whose specific gravities are  $\cdot 820$ ,  $\cdot 840$ ,  $\cdot 860$ ,  $\cdot 880$ ,  $\cdot 920$ ,  $\cdot 940$ ,  $\cdot 960$ ,  $\cdot 980$ , which have a common difference of  $\cdot 02$ . This adjustment being made, it results, from a mathematical investigation of this instrument made by Mr. Lubbock, that the same division of its stem suits itself to every poise. When, for instance, the

poise corresponding to  $\cdot 920$  is attached, the specific gravities corresponding to successive divisions, ascend by the same increments from that specific gravity to  $\cdot 940$ , as when the poise for  $\cdot 820$  was attached, they ascended from that specific gravity to  $\cdot 840$ . This property obtains at least *practically*, the error in no case exceeding  $\cdot 0001$  when the instrument is accurately divided for the poise  $0\cdot 900$ . The instrument as thus made for the purposes of the excise, possesses this beautiful and characteristic property, with this accuracy, only for specific gravities less than that of water, and within the range here assigned to it. It may, however, no doubt, be adapted to a more general use.

The *sensibility* of an Hydrometer is the variation in the depth of its immersion which any given difference in the specific gravity of the fluid, in which it is immersed, will produce. It is greater, as the weight of the portion beneath the stem is *greater*, and as the specific gravity of the fluid and the section of the stem are *less*. It is also greater as the length of the stem beneath the zero of the scale is greater. An Hydrometer should, therefore, be made as heavy, and with as long and slender a stem, as possible. So that when placed in water, it may sink to the greatest convenient depth upon the stem.

## THE AREOMETER.

306. AN instrument constructed by M. de Parcieux, and called by him the Areometer, is said to have possessed extraordinary sensibility. It is, in fact, an Hydrometer, whose sensibility is produced by giving extreme slenderness to its stem.

It is represented in the accompanying figure; *CB* is a vial partially loaded with shot, to keep it *steadily* in an upright position, bringing its centre of gravity beneath its *metacentre*. (Art. 294.) In the cork of this vial is inserted a straight wire *AB*, about one-twelfth of an inch in diameter, and thirty inches long, at the top of which is a cup *A*. The loading is so adjusted, that when the instrument is placed in water of a medium temperature, it will sink to a point on the wire about an inch above *B*. Being placed in any lighter fluid it will continue to sink, until the additional immersion of the stem causes such an additional displacement of fluid, as shall again make the whole weight of the fluid displaced equal to the weight of the instrument. It is clear that the more slender the stem, the greater the additional depth to which the whole must be sunk to bring about this displacement. A scale is placed by the side, and the division on this scale, corresponding with the edge of the cup or the top of the wire being observed, and referred to an accompanying table, determines the specific gravity of the fluid.



This instrument was invented for the purpose of comparing the specific gravities of different kinds of water. Such is its extreme sensibility, that the variation of density produced by the falling of the sun's rays on water of the common temperature, will instantly cause it to sink some inches; and the throwing of the smallest conceivable quantity of a soluble substance into the water, will produce a visible effect upon it. An objection to its use is found in the elevation of the liquid by capillary attraction round its slender stem, which is different in different liquids. By means of the cup, the Areometer may be loaded so as to sink always to the same depth, and thus act on the principle of *Fahrenheit's Hydrometer*, now about to be described.

## FAHRENHEIT'S HYDROMETER.

307. THE principal obstacle to the use of the simple Hydrometer, is the inconvenience and difficulty of calculating and marking against the different divisions of the stem of each in-

strument, or registering, in a table attached to each, a different scale of specific gravities; and constructing the stem of that perfectly uniform thickness, which is necessary to the accuracy of the observations\*. To obviate these difficulties, *Fahrenheit* conceived the idea of sinking the *Hydrometer* always to the same depth, by means of weights to be placed in a cup at the end of the stem.

Let the weight necessary to sink such an instrument to the given depth in water, be observed. This weight, added to the weight of the instrument itself, will equal the weight of the water it displaces when *floating* at that depth. Let it now be placed in the fluid whose specific gravity is to be determined; and let weights be placed in the cup until it is sunk again to the same depth as before. The weights placed in the cup together with the weight of the instrument, will then equal the weight of the fluid which it displaces. But, having been sunk to the same depth in the water as in the fluid, it displaced as much of the water before, as it does now of the fluid. We know, therefore, the weights of equal volumes of the fluid to be examined, and water. Dividing, therefore, (Art. 300,) one of these by the other, we obtain at once the specific gravity of the fluid. The accompanying figure represents one of these instruments,

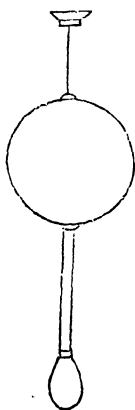

made by Mr. Bate, for the Excise Committee, and called by him the Gravimeter.

#### NICHOLSON'S HYDROMETER.

308. THIS instrument is so contrived as to determine the specific gravities of *solid* as well as *fluid* bodies. Its application to the determination of the specific gravities of fluid bodies, is precisely that of the instrument last described. A is a hollow ball, in continuation of one of the diameters of which, is fixed an exceedingly slender steel wire BC, about one-fortieth of an inch in diameter. To the opposite extremity of this diameter of the ball, is fixed a stirrup DF carrying a heavy brass dish F. The wire CB supports also at its extremity a light dish B. The weight of the dish F is such, as to preserve the stability of the instrument, and is further so adjusted as to cause it to sink to

\* This difficulty would evidently be got rid of, if after having fixed a scale of specific gravities for *one* instrument, we could construct others precisely of the same form, dimensions, and weight.

a point  $\kappa$ ; marked about the middle of the stem, when the instrument is placed in distilled water at the temperature of  $60^{\circ}$ , and loaded with a weight of 1000 grains in the dish B. To determine the specific gravity of a solid by means of Nicholson's Hydrometer, let it be allowed to float in distilled water at temperature  $60^{\circ}$ . Let the solid be placed in the upper dish, and as many grain weights thrown in with it, as will cause the instrument to sink accurately to the given division  $\kappa$ . These grain weights, together with the weight of the solid, are then equal to 1000 grains. For 1000 grains, together with the weight of the instrument, sink it to  $\kappa$ ; also, the weight of the solid, together with the grains thrown in, and the weight of the instrument, sink it to  $\kappa$ ; the first-mentioned weights are, therefore, equal to the others; and taking the weight of the instrument from both, it follows, that the weight of the solid and the grains added to it equal together 1000 grains.

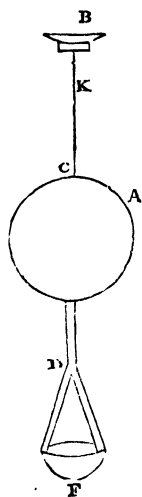

Hence, therefore, it also follows, that the weight of the solid is 1000 grains, diminished by the grains thrown in with it. We therefore get accurately the weight of the solid by subtracting from 1000 grains, the number of grains which must be added to the solid in the cup B, to sink the instrument to  $\kappa$ . Let the solid be now placed in the lower dish; and again sink the instrument to  $\kappa$ , by means of grain weights placed in the upper dish. These weights then, together with the weight or downward pressure of the solid in the water, will for the same reasons as before, equal 1000 grains. Diminishing, therefore, 1000 grains by the number of grains thrown into the upper dish, we have the weight of the solid in water. The difference between this and its actual weight, will be the weight of the water it displaces; and the quotient of its actual weight by the weight of water it displaces, is its specific gravity. (Art. 300.)

The accuracy of the results given by this instrument, depends upon the accuracy of the observed coincidence of the division  $\kappa$ , with the surface of the fluid. Now the wire BC is made so thin, that an inch of it displaces only one-tenth of a grain of water. Hence, therefore, the 100th part of a grain too much or too little in the upper cup, will cause the mark to sink below or rise above the surface of the fluid one-tenth of an



of the limits within which an error is possible, further than this. On the same principle, that by measuring their specific gravities, we may determine whether metals be alloyed or pure, we may also find whether fluids be adulterated or not, and in some cases, fix the amount of the adulteration. It is for this purpose, that the Hydrometer is principally used. All the varieties of ardent spirits are mixtures of pure alcohol with other ingredients, of which the principal is water. On the proportion in which the alcohol enters into their composition depends, in most cases, their value. It becomes, therefore, a matter of the highest importance, to commerce, and to the revenue, that some easy method should be devised for ascertaining this proportion. Sikes' Hydrometer is expressly constructed with this view.

309. The following remarkable example of the commercial advantages which have resulted from the use of the Hydrometer, is mentioned by M. Dupin in his work entitled, *Mécanique appliquée aux Arts*. Brandies have, according to their greater or less degree of concentration, a greater or less specific gravity. The French, who first measured these degrees of concentration by means of Hydrometers, first gained by this means the advantage of being able to make their brandies always, and with certainty, of those precise degrees of strength which were required by the different markets to which they carried them. The Spaniards, whose strong full-bodied wines are eminently suited to distillation, endeavoured to enter into competition with the French, in the sale of brandies. But as they were not acquainted with the method of measuring their degrees of concentration by means of Hydrometers, they were obliged to content themselves with the following clumsy and awkward substitute. A drop of oil was allowed to fall from a given height on the surface of the brandy to be examined, and as it was seen to sink in it, to a greater or a less depth, the brandy was concluded to be of a greater or less strength. This *measure* failed them perpetually, and the result was, that their foreign market was supplied with brandies on the strength of which no reliance could be placed.

Spanish brandies having thus acquired a bad reputation in the market, they were purchased by the French merchants, concentrated to the requisite degree, as shown by the Hydrometer, and eventually resold as French. By the sale of this description of brandy in the northern market alone, the French, before the revolution, realized an annual profit of four millions of francs. The Spaniards now at length understand the use of the Hydrometer, and carry their brandies to market themselves.

## TABLE OF SPECIFIC GRAVITIES.

Acid, Acetic.....	1.062	Blood, crassamentum of .....	1.245
Arsenic .....	3.391	Do. human, serum of.....	1.030
Arsenious .....	3.728	Borax .....	1.714
Benzoic .....	0.667	Butter .....	0.942
Boracic, crystallized ...	1.479	Camphor .....	0.988
Do. fused .....	1.803	Caoutchouc, or India rubber	0.933
Citric .....	1.034	Carnelian, speckled.....	2.613
Formic .....	1.116	Chalcedony, common, from	
Fluoric .....	1.060	2.600 to	2.650
Molybdic .....	3.460	Chalk .....	from 2.252 to 2.657
Muriatic.....	1.200	Chrysolite .....	3.400
Nitric .....	1.271	Cider .....	1.018
Do. highly concentrated	1.583	Cinnabar, from Almaden ....	6.902
Phosphoric, liquid.....	1.558	Coals.....	from 1.020 to 1.300
Do. solid .....	2.800	Copal .....	1.045
Sulphuric .....	1.850	Coral, red .....	from 2.630 to 2.857
Agate .....	2.590	white.....	from 2.540 to 2.570
Alcohol, Absolute .....	0.797	Corundum .....	3.710
Do. highly rectified.....	0.809	Crystalline Lens of the Eye	1.100
Do. of commerce .....	0.835	Diamond, oriental, colourless	3.521
Alum .....	1.714	Do. coloured varieties,	
Amber .....	from 1.065 to 1.100	from 3.523 to	3.550
Ambergris .....	from 0.780 to 0.926	Do. Brazilian .....	3.444
Amethyst, common.....	2.750	Do. coloured varieties,	
oriental .....	3.391	from 3.518 to	3.550
Amianthus .....	from 1.000 to 2.313	Dolomite .....	from 2.540 to 2.830
Ammonia, aqueous .....	0.875	Dragon's Blood (a resin) ....	1.204
Arragonite .....	2.900	Ether, Acetic .....	0.866
Azure-stone .....	2.850	Muriatic .....	0.729
Barytes, Sulphate of, from		Nitric .....	0.908
4.000 to	4.865	Sulphuric from 0.632 to	0.775
Do. Carbonate of, from		Emerald .....	from 2.600 to 2.770
4.100 to	4.600	Euclase.....	from 2.900 to 3.300
Basaltes .....	from 2.421 to 3.000	Fat of Beef .....	0.923
Beryl, oriental.....	3.549	Hogs .....	0.936
Do. occidental.....	2.723	Mutton .....	0.923
Blood, human .....	1.053	Veal .....	0.934

Felspar .....	from 2·438 to 2·700	Hornstone .....	from 2·533 to 2·810
Flint, black .....	2·582	Hyacinth .....	from 4·000 to 4·780
Gamboge .....	1·222	Jasper .....	from 2·358 to 2·816
Garnet, precious, from 4·000 to 2·230		Jet .....	1·300
Do. common, from 3·576 to 3·700		Indigo .....	1·009
Gases,—Atmospheric Air ....	1·000	Ironstone from Carron .....	3·281
Ammoniacal .....	0·590	Do. Lancashire....	3·573
Carbonic Acid .....	1·527	Isinglass .....	1·111
Carbonic Oxide .....	0·972	Ivory .....	1·825
Carburetted Hydrogen .....	0·972	Lapis Nephriticus .....	2·894
Chlorine.....	2·500	Lard.....	0·947
Chlorocarbonous Acid 3·472		Lead, Glance or Galena, from Derbyshire ....	from 6·565 to 7·786
Chloropruessic Acid ..	2·152	Limestone, compact, from .....	2·386 to 3·000
Cyanogen .....	1·805	Magnesia, native, Hydrate of .....	2·330
Euchlorine .....	2·440	Do. Carbonate of, from 2·220 to 2·612	
Fluoboric Acid .....	2·371	Malachite, compact, from .....	3·572 to 3·994
Fluosilicic Acid .....	3·632	Marble, Carrara .....	2·716
Hydriodic Acid .....	4·340	white Italian.....	2·707
Hydrogen .....	0·069	black-veined.....	2·704
Muriatic Acid .....	1·284	Parian .....	2·560
Nitric Oxide .....	1·041	Mastic (a resin) .....	1·074
Nitrogen .....	0·972	Melanite, or black Garnet, from 3·691 to 3·800	
Nitrous Acid.....	2·638	Metals, Antimony .....	6·702
Nitrous Oxide .....	1·527	Arsenic .....	5·763
Oxygen .....	1·111	Bismuth .....	9·880
Phosphuretted Hydrogen .....	0·902	Brass ...from 7·824 to 8·396	
Prussic Acid .....	0·937	Cadmium .....	8·600
Sub-carburetted Hydrogen .....	0·555	Chromium .....	5·900
Sub-phosphuretted do. 0·972		Cobalt.....	8·600
Sulphuretted do. 1·180		Columbium.....	5·600
Sulphurous Acid ....	2·222	Copper .....	8·900
Glass, crown.....	2·520	Gold, cast .....	19·25
green .....	2·642	Do. hammered.....	19·35
flint .....from 2·760 to 3·000		Iridium, hammered ..	23·00
plate .....	2·942	Iron, cast at Carron .	7·248
Granite.....from 2·613 to 2·956		Do. bar hardened or not	7·788
Gum arabic .....	1·452	Lead .....	11·35
cherry-tree .....	1·481	Manganese .....	8·000
Gunpowder, loose .....	0·836	Mercury, solid, 3° below 0 of Fahr. ....	15·61
shaken.....	0·932	Do. at 32° of Fahr....	13·61
solid .....	1·745	Do. at 60° of Fahr....	13·58
Gypsum, compact, from 1·872 to 2·288		Do. at 212° of Fahr.	13·37
crystallized, from 2·311 to 3·000		Molybdenum .....	8·600
Heliotrope, or Bloodstone, from 2·629 to 2·700		Nickel, cast.....	8·279
Honey .....	1·450	forged.....	3·666
Honeystone, or Mellite, from 1·560 to 1·666		Osmium and Rhodium, alloy of.....	19·50
Hornblende, common, from 3·250 to 3·830		Palladium .....	11·80
basaltic, from 3·160 to 3·333		Platinum .....	21·47
		Potassium at 59° Fahr.	0·865
		Rhodium.....	10·65

Metals, Selenium.....	4·300	Pitchstone .....	from 1·970 to 2·720
Silver .....	10·47	Plumbago, or Graphite, from	
hammered ...	10·51	.....	1·987 to 2·400
Sodium at 59° Fahr.	0·972	Porcelain from China .....	2·384
Steel, soft .....	7·833	Sèvres .....	2·145
tempered .....	7·816	Porphyry .....	from 2·452 to 2·972
hardened .....	7·840	Do. Seltzer .....	1·003
tempered and		Proof-spirit .....	0·923
hardened ...	7·818	Pumice-stone ...from 0·752 to 0·914	
Tellurium, from		Quartz .....	from 2·624 to 3·750
5·700 to 6·115		Realgar .....	from 3·225 to 3·338
Tin, Cornish .....	7·291	Rock-crystal ...from 2·581 to 2·888	
Do. hardened.....	7·299	Ruby, Oriental .....	4·283
Tungsten.....	17·40	Sal Gem .....	2·143
Uranium.....	9·000	Sapphire, Oriental, from	
Zinc.....from 6·900 to 7·191		4·000 to 4·200	
Mica.....from 2·650 to 2·934		Sardonyx .....	from 2·602 to 2·628
Milk.....	1·032	Scammony of Smyrna.....	1·274
Mineral Pitch, or Asphaltum,		Aleppo .....	1·235
from 0·905 to 1·650		Schorl .....	from 2·922 to 3·452
Mineral Tallow .....	0·770	Serpentine .....	from 2·264 to 2·999
Myrrh (a resin) .....	1·360	Shale .....	2·600
Naphtha .....	from 0·700 to 0·847	Silver Glance ...from 5·300 to 7·208	
Nitre .....	1·900	Slate (drawing) .....	2·110
Obsidian .....	from 2·348 to 2·370	Smalt .....	2·440
Oils, Essential—Amber .....	0·868	Spar, Fluor .....	from 3·094 to 3·791
Anise-seed ...	0·986	Do. calcareous ...from 2·620 to 2·837	
Caraway-seed .	0·904	Do. double refracting from	
Cinnamon ...	1·043	Castleton .....	2·724
Cloves .....	1·036	Spermaceti .....	0·943
Fennel .....	0·929	Spodumene or Triphane, from	
Lavender .....	0·894	3·000 to 3·218	
Mint, common	0·898	Stalactite .....	from 2·323 to 2·546
Turpentine ...	0·870	Steatite .....	from 2·400 to 2·665
Wormwood ...	0·907	Steam of water .....	0·481
Expressed—Sweet Al-		Stilbite.....from 2·140 to 2·500	
monds....	0·932	Strontian, Sulphate of, from	
Codfish.....	0·923	3·583 to 3·958	
Filberts .....	0·916	Do. Carbonate of, from	
Hempseed ...	0·926	3·658 to 3·675	
Linseed .....	0·940	Stone, Bristol ...from 2·510 to 2·640	
Olives .....	0·915	cutlers' .....	2·111
Poppyseed ...	0·939	grinding .....	2·142
Rapeseed ...	0·913	hard .....	2·460
Walnuts, from		paving ...from 2·415 to 2·708	
0·923 to 0·947		Portland .....	2·496
Whale .....	0·923	rotten .....	1·981
Opal, precious.....	2·114	Sugar .....	1·606
common...from 1·958 to 2·114		Sulphur, native .....	2·033
Opium .....	1·336	fused.....	1·990
Orpiment.....from 3·048 to 3·500		Talc .....	from 2·080 to 3·000
Oyster-shell.....	2·092	Tallow .....	0·941
Pearl, Oriental...from 2·510 to 2·750		Topaz .....	from 4·010 to 4·061
Pearlstone .....	2·340	Tourmaline .....	from 3·086 to 3·362
Peat .....	from 0·600 to 1·329	Turquoise.....from 2·500 to 3·000	
Peruvian Bark.....	0·784	Ultramarine.....	2·360
Phosphorus .....	1·770	Uranite .....	2·190

Vesuvian .....	from 3·300 to 3·575	Wood, Elder-tree .....	0·695
Vinegar .....	from 1·013 to 1·080	Elm-tree .....	0·671
Water, distilled .....	1·000	Filbert-tree .....	0·600
sea .....	1·028	Fir, Male.....	0·550
of Dead Sea .....	1·240	Do. Female.....	0·498
Wax, bees' .....	0·964	Hazel .....	0·600
white .....	0·968	Jasmin, Spanish .....	0·770
shoemakers' .....	0·897	Juniper-tree .....	0·556
Whey, cows' .....	1·019	Lemon-tree .....	0·703
Wine, Bourdeaux .....	0·993	Lignum Vitæ .....	1·333
Burgundy.....	0·991	Linden-tree .....	0·604
Constance.....	1·081	Mastick-tree .....	0·849
Malaga .....	1·022	Mahogany .....	1·063
Port .....	0·997	Maple-tree .....	0·750
White Champagne .....	0·997	Medlar.....	0·944
Wood, Alder .....	0·800	Mulberry, Spanish .....	0·897
Apple-tree .....	0·793	Oak-heart, 60 years old .....	1·170
Ash .....	0·845	Olive-tree .....	0·927
Bay-tree .....	0·822	Orange-tree.....	0·705
Beech .....	0·852	Pear-tree .....	0·166
Box, French .....	0·912	Plum-tree .....	0·785
Dutch .....	1·328	Pomegranate-tree .....	1·351
Brazilian, Red.....	1·031	Poplar-tree .....	0·383
Campeachy .....	0·913	Do. White Spanish .....	0·529
Cedar, Wild.....	0·596	Quince-tree .....	0·705
Palest .....	0·613	Sassafras .....	0·482
Indian .....	1·315	Vine .....	1·327
American .....	0·561	Walnut.....	0·681
Cherry-tree .....	0·715	Willow .....	0·585
Citron .....	0·726	Yew, Dutch .....	0·788
Cocoa-wood.....	1·040	Spanish .....	0·807
Crab-tree .....	0·765	Knot of 16 years old .....	1·760
Cork .....	0·240	Woodstone .....	from 2·045 to 2·675
Cypress, Spanish .....	0·644	Zeolite .....	from 2·073 to 2·718
Ebony, American .....	1·331	Zircon .....	from 4·385 to 4·700
Do. Indian.....	1·209		

## PNEUMATICS.

310. ALL the fluids of which we have hitherto treated, belong to the class called liquids. These fluids we at once recognise to be such; indeed they are those material substances from which the very notion or idea, which we attach to a fluid, is drawn.

There is, however, another class of fluids, whose fluid properties are by no means so easily recognised, and from which indeed we derive so few of the sensations that come to us from other material substances, that we scarcely admit them to be matter. These are called AIRS or AERIFORM FLUIDS, and the science which treats of them, is called PNEUMATICS. With the properties of one fluid of this class we are far more intimately concerned than with those of any other material substance; we are, in fact, perpetually immersed in that fluid, it enters most intimately into the composition of our bodies, we swallow a huge volume of it at every *inspiration*, and the very principle of life within us appears to feed upon it. One of its constituent elements is indeed so necessary to the sustenance of the power of living, that to cease to breathe, and to cease to live, have come to be used as synonymous expressions. This fluid is the atmosphere. It surrounds the globe of our earth on every side, forming a continuous spherical shell of vapour, which encloses the earth itself, as its solid portion, or nucleus.

Were it not that we are endued by nature with a tendency to *speculate* on the phenomena around us, and to *reason* upon the sensations to which we are subjected, we might pass on from infancy to the grave without, perhaps, even recognising the existence of this fluid, certainly without distinguishing any of its properties.

But few of those sensations by which we are accustomed to recognise the existence of external things, appear to come to us from the air. We do not see it as we do other material substances, we cannot touch it as we do them, we are not conscious that it has weight as they have; it does not appear to require any force to move it as it does to move them; in short, there does not *seem* to be a single sense affected by it; although it unquestionably enters largely into the constitution of every single sensation.

One great cause of the deception under which we thus labour, is that we are *born* into the air. Our senses are subjected *continually* to those affections which, if the mind took notice of them, would constitute perceptions of its existence from that period when it takes notice of nothing\*. There are, however, other causes arising out of the conditions of the equilibrium of fluids as explained in the preceding chapters, which enter largely into the explanation of this mystery.

The first of these is that, by the nature of that equilibrium, when a solid body, of whatever form, is immersed in a heavy fluid, the pressure of that fluid when at rest, produces in it no tendency whatever to move *horizontally*; there being, for each horizontal pressure on one side of it, an equal and opposite horizontal pressure on the opposite side, which two pressures neutralize one another. Also the *vertical* pressure of the fluid produces in the body, a tendency to move upwards, equal only to the weight of the fluid it displaces.

From the above it follows that the air in which we are immersed does not, by reason of its pressure when at rest, tend to move us *horizontally*, in one direction more than another; it presses us equally in *all* directions, and this is the case in every position into which we can throw our bodies; also that the force by which it presses us *upwards*, or buoys us up towards the higher regions of the atmosphere, is so small, being only the weight of the air we displace, that it is entirely neutralized and greatly surpassed by our weight; whilst, moreover, we are at any time altering our position, the fluid pressure adjusts itself so rapidly into a state of equilibrium that we are unconscious of that state being for an instant destroyed.

But it will be said that although this equality of the pressure of the air all round us, be sufficient to account for our not being called upon to oppose any effort to it in any *particular direction*, and for its opposing no obstacle to a change of our position; yet it is not sufficient, to account for our not being conscious of its tendency to *press* the different parts of our

\* It seems to be a law of our nature, that the mind should not take notice of those affections of the organs of sense which are constantly repeated, and, therefore, *à fortiori*, of those which are *continual*. Examples of this are exceedingly numerous, and must present themselves to the mind of every one. Were it not for this *habit* of the mind how many secrets of nature would be laid open to us! May it not, for instance, be possible that all the internal operations of the human body, each affecting some nerve or organ of sense, would, if the mind did but take notice of the affection, present itself to *its* eye, as completely as the parts of a piece of mechanism to the external organ.

bodies together, and *crush* them; since the opposite and equal forces which have been spoken of above, whilst they neutralize and destroy one another, tend, at the same time, to destroy the organization of the parts between them by compressing those parts; thus, the pressure on the opposite sides of one of the fingers should, it may be asserted, tend to destroy that delicate ramification of arteries, veins, nerves, and muscles which cover the bones of the finger; and the perception of that pressure ought to be transmitted by the nerves. Similarly, the pressure on opposite sides of the upper portion of the body, must tend to impede the motions of the lungs, and to break in the cavity of the thorax. This objection is of great importance, and deserves particular attention, especially as it leads to a striking view of the economy of the human frame.

311. The parts of the body are either hollow, as the chest; they are composed of solid parts or bones; of fleshy or muscular parts; of nerves and tendons; or of vessels *filled* with liquids, as veins and arteries. The parts called hollow are not in reality so, but are filled with the same fluid, the air, in which the whole of the external portion of the body is immersed; and this air contained internally, has a direct communication, through the passages of the wind-pipe and the œsophagus, with the external air; so that, in fact, the air contained internally and the external air, form different portions of one continuous fluid. Hence, therefore, by what has been said before, the pressure of this fluid horizontally, upon any given portion of the cavity of the chest from *within*, must be precisely equal to that upon a corresponding portion of the convex surface of the ribs from *without*; these two corresponding portions forming, in fact, *opposite sides* of a body immersed in a fluid. Thus the pressure of the air externally upon the ribs, is borne always, by a corresponding opposite pressure of the *air* within; and neither pressure is felt to have a tendency to alter the form of the cavity of the chest.

If, however, we exhale any portion of air from the chest, we become immediately conscious of a *diminution* of the internal pressure outwards, and an *excess* of the external pressure; the chest becomes oppressed, and by a peculiar mechanism supplied by nature for that purpose, its dimensions contract, until the included air is again sufficient in quantity to supply the requisite pressure from within.

It is for reasons similar to those assigned above that divers, when at a great depth, experience a severe pressure upon the ribs; the external pressure upon the chest being increased by



the great weight of the superincumbent fluid, and thus made to exceed the opposite internal pressure of the contained air.

Those portions of the body which do not communicate with the external air and thus become filled with it, are all, whatever be their nature, completely saturated and permeated by fluids. Thus the bones are porous, and their pores are, every where, occupied by certain fluid secretions; the muscular portion of the body, or the flesh, is every where saturated by the blood; the nerves and sinews are fascicles of tubes, each being apparently a canal serving as the conduit of a fluid.

From the above then it appears that the mass of the human body may be considered as an accumulation of solid atoms, each separately immersed in a fluid. This being the case, it follows that the pressure upon any portion of the external surface of the body is propagated equally throughout its *substance*. (Art. 244.) by the intervention of the fluids which permeate it, and that each solid particle thus sustains pressures equal in every possible direction; so that, by reason of these pressures, it can have no tendency to move either in one direction or another. The pressures upon each particle thus separately neutralizing one another, it follows that the particles do not press *upon one another*\*. Thus then we see a reason why the external pressure of the atmosphere, which is exceedingly great, being altogether little short of 30,000 pounds on each individual, does not, nevertheless, tend to press any of the component parts of the body upon, or against, one another, and producing, therefore, no excitement of the nerves, is not felt.

We may also see a reason why, when the body is immersed to a great depth in the water, (by means of a diving-bell or otherwise,) and the external pressure upon it, is thus rendered very far greater than the atmospheric pressure; yet, by reason of the equal distribution of that pressure over the surface of the body, through the medium of the fluid in which it is immersed, and also by reason of the equal *transmission* of the pressure through the system, by the intervention of the fluids which are contained in, and which pervade it; there results no perceptible pressure upon those delicate nerves which are every where interwoven in our frame, and which the slightest *unequal* pressure is sufficient to irritate.

Were the enormous pressure of the atmosphere any otherwise applied to our bodies, than by the intervention of the fluid in which we breathe, it would be utterly impossible that the

\* Of course it is here supposed that the external pressures spoken of do not alter the external form of the body.

motions of the parts of the body, constituting life, should proceed; the slender and fragile mechanism, indeed, of its organs could not fail to be destroyed. By that admirable property, however, of the equal distribution of fluid pressure, not only are we enabled to sustain the 30,000 pounds' weight of atmospheric pressure without feeling it, but that pressure may be *doubled* by immersing the body thirty-six feet under water in a diving-bell, and yet no single nerve, not even the most delicate of the millions which overspread the body will, by reason of that pressure, experience the least perceptible excitement; although these nerves are of such sensibility as to enable us not only to perceive, but to appreciate, to measure and compare, the slightest pressures which (being unequal) tend to alter the form of the surface of the body. Even the chest will, under these circumstances, suffer no oppression; for the pressure of the water being transmitted through the medium of the air in the diving-bell, equally to the external and internal surface of the chest, these external and internal pressures will neutralize one another, however great the weight of the superincumbent water may be.

Such are the effects which result from the body's being immersed in a fluid, and from its parts being (according to an expression of Paley,) *packed* in fluids. We now see plainly how the air *may* be (as it really is) a *fluid* possessing weight, and, therefore, pressing heavily upon us, and yet we be altogether unconscious of the pressure.

We may, however, very readily put the matter to the test of experiment. Let us destroy the equality of atmospheric pressure, spoken of above, let us remove the air from any one portion of the body; we shall then at once be conscious of the existence of pressures upon the other portions, and on the great advantages we derive from an absolute and entire immersion in it. This removal of the air may be effected by various means; there is, however, a machine called the air-pump, which is commonly used and expressly intended for that purpose, and of which the principles and action will, in the course of this work, be fully explained. By means of this machine, the air may be removed from any given portion of the body; its pressure upon the rest of it will then at once be perceived. If, for instance, the hand be applied so as to cover the open top of a vessel, of which the lower portion communicates with the air-pump; and if the pump be then put in action so as to remove the air from the vessel, and, therefore, from the under surface of the hand, the pressure of the air upon the

upper surface will at once become apparent; the hand will be firmly pressed down upon the edges of the vessel, and, at length, it will be found impossible to move it; the blood-vessels will become distended, the back of the hand will be bent inwards, and the operation may be carried on until a pressure is produced equal to the weight of a column of thirty inches of mercury, a weight probably sufficient to rupture the mechanism of the hand.

The process of cupping is an example of this *partial* removal of pressure from the surface of the body. A small portion of alcohol is put into the cupping-glasses and lighted; by the heat thus produced the air which before occupied the glass is in a great measure expelled, and its place supplied by a highly-attenuated vapour of alcohol. In this state the open extremity of the glass is applied to the surface of the skin; the flame is extinguished, the vapour becomes condensed again into a liquid, the air loses its heat, and with its heat its tendency to expand; thus its pressure upon the surface of the body (underneath the glass) becomes less than before, and less than the pressure upon other portions of the body; and the result of this unequal pressure is an immediate disorganization of the surface beneath the glass; the flesh and muscular parts swell out in a surprising manner, the vessels become distended, and blood is at length seen to gush from the pores of the skin. The escape of the blood is however commonly assisted by first puncturing the surface of the skin.

Suction presents another striking example of the partial removal of pressure. There is a certain operation of the muscles by which the air may be removed from the cavity of the mouth; if this exhaustion takes place when the lips are applied to any portion of the skin, the result will be a removal of the pressure from that portion of the surface of the body, and a consequent displacement of the skin beneath: moreover, the exterior surface of the lips sustaining the atmospheric pressure, whilst the interior portion in contact with the skin is free from it, the two are brought closely in contact and pressed together.

It is thus that snails attach themselves firmly to walls or to the trunks or boughs of trees, and may be seen even to crawl with their bodies suspended beneath them. The under portion of their bodies is furnished with powerful muscles, which enable them to form a hollow space or cavity in any portion of its length. Their method of fixing themselves to any surface is to raise their bodies into a hollow or cavity, producing a vacuum underneath this cavity, the edges of which are closely pressed

upon the surface, and the whole body suspended to it by the external atmospheric pressure. Attaching in this manner, different portions of their bodies successively to different parts of the surface on which they wish to move, they may be seen walking suspended not only as to their bodies, but the shell which serves them as a habitation, not only up perpendicular walls, but along the smooth surface of the ceiling of a room.

There is a plaything of children called a sucker, which acts precisely upon the principle we have been explaining. It consists of a circular piece of leather, which is exceedingly soft and pliable, and suspended by its centre from a string. If this be wetted and applied to the surface of a stone or any smooth heavy mass, and then an attempt be made to remove it by pulling the string, it will be found to oppose a powerful resistance to separation from the surface on which it has fixed itself; and rather than yield, it will, if the weight of the mass be not considerable, carry it away with it.

The reason of this is obvious. The string being pulled, the leather is slightly raised in its centre, and the cavity beneath it is a vacuum, no air having been allowed to enter by reason of the close contact of the edges of the wet leather with the stone. This being the case, the pressure of the air is removed from that portion of the stone which is beneath the surface of the leather; its pressure upon the opposite side of the stone is, therefore, unsustained; the stone is, therefore, by that unsustained force, pressed towards the leather; again, by the pressure of the atmosphere on the *external* surface of the leather it is pressed against the stone. Thus then, the leather and stone are attached to one another.

It is precisely upon the principle explained above, that flies are enabled to fix themselves upon a perpendicular pane of glass or upon the ceiling of a room. They have a contrivance in their feet by which they are enabled to raise the central portions of these, as the centre of the sucker is raised by the string; a vacuum being thus formed underneath the foot, it becomes fixed upon the surface on which it is planted.

312. It has been proved that any substance immersed in a heavy fluid, besides those *horizontal* pressures, which acting equally in opposite directions produce no tendency to horizontal motion, sustains further certain *vertical* pressures whose effects are not thus neutralized, and which produce in it a tendency to upward motion, equal to the weight of fluid it displaces.

Our bodies then being immersed in the air, sustain, each, an upward pressure equal to the weight of air which they displace.

Why, then, it may be said, are we not conscious of that upward pressure? The answer is obvious; it is because the weight of the body *exceeds* the weight of the air it displaces. The downward pressure, therefore, exceeds the upward pressure; and we are, therefore, only conscious of weight.

This, however, is not only true of the aggregate of the upward pressures upon different parts of the body, but of each in particular. If, for instance, we imagine the body to be divided into any number of slender vertical columns, then the *upward* pressure upon that portion of its surface which forms the base of any one of these will equal the weight of a column of air precisely of the same dimensions with that column; and the downward pressure of the column will equal its *weight*, and, therefore, will exceed the upward pressure; we shall thus be unconscious of any upward pressure upon the surface spoken of; and the same is true of every other portion of the surface of the body.

Also, it has been shown, that when a body is *totally* immersed, the resultant of the pressures of the fluid upon it necessarily passes through its *centre of gravity*, and acts in a vertical direction; and the resultant of the weights of the parts acting also *there*, *exceeds* this *upward* resultant; we are, therefore, unconscious of the existence of the latter pressure. This we certainly should not be, if its direction were not thus always through the centre of gravity of our body; there would be certain, and only certain positions of equilibrium, as in the case of floating bodies; and our bodies could assume no positions, other than these, without a certain expense of muscular energy. When we inclined the body, for instance, the upward pressure of the air would tend to bring it back into its previous position, or to cause it to recede still further from that position, and would thus be a perpetual source of annoyance to us.

313. If we could by any means lighten the substance of our bodies so as to render them lighter than the air they displace, we should immediately ascend and float in the air. We have seen that fishes have the power to expand certain portions of their bodies so as to cause the quantity of water they displace, to exceed the weights of the quantities of fluid they displace, or be less than them, according as they wish to rise to the surface of the water, or to sink to any required depth beneath. Some of them would seem to have the power of carrying this expansion still further, so as to pass from the water into the air, and displace of the latter, a quantity weighing nearly the same with themselves; these are called Flying-fish. And

in the same manner there are certain birds which would seem to be able so to contract their dimensions, as to sink in water to any depth they may wish. We may easily construct bodies lighter than the air they displace; its upward pressure upon such bodies will then exceed their weight, and they will ascend in it.

It is thus that balloons are made. Certain fluids may be produced artificially which are greatly lighter than the air they displace. These fluids are of the kind called gases or elastic fluids. If a light vessel, capable of containing one of these fluids—as, for instance, a bag of glazed paper, or of thin silk—be filled with that fluid, and then left to itself, it will immediately begin to ascend, provided the weight of the vessel be not such, as together with that of the contained fluid to equal or exceed the weight of the air displaced.

Fluids lighter than the air may be obtained from a variety of different substances, and in a variety of different ways. The gas commonly burnt in our streets is a fluid of this kind; and large silken bags filled with this gas displace a quantity of air whose weight is greater than their own weight; and are for that reason made to ascend by the upward pressure of the air. They will carry with them a weight nearly equal to the difference between their own weight and that of the air which they thus displace.

Not only, however, can we make artificially other liquids lighter than the air, but we can make any one portion of the air lighter than the rest. This we may do by heating it. All bodies expand or increase their dimensions by the application of heat, and of all bodies the air is probably that which expands most readily, or is most sensitive to the variations of heat. If, therefore, we take any portion of the air around us, which is precisely of the same nature as the rest, and therefore, displaces a portion of it exactly *equal* in weight to itself; and expand that air, by the application of heat, then will it displace a portion of the surrounding air, *greater* than itself in bulk, and the result will be, that on the principles we have explained, it will be made to *ascend*. This expansion of certain portions of the air and their consequent ascent through the surrounding air is a process which we observe to be continually going on around us. The smoke which ascends through our chimneys, is air rarefied by the heat of the fire, and carrying with it small portions of unconsumed coal. The operation takes place, however, on a much more magnificent scale under the influence of the sun. Within the tropics, where its power is greatest, the air is conti-

nally undergoing rarefaction, and is thus rendered lighter than that on either side of them; it is, therefore, weighed up, and made continually to ascend by the pressure of that air, which as continually occupies the space which it leaves. As the heated air ascends, it loses its heat, and therefore contracts its dimensions, and moving off towards the poles eventually descends to the earth's surface, to return again to the equator in its turn. Thus, there is a continual circulation of air kept up between the polar and equatorial regions of the earth; combining with the rotation of the earth to constitute that prevailing direction of the wind towards the tropics, so well known to sailors under the name of the Trade Wind.

Similar effects to these, produced on the surface of the earth by local variations of temperature, constitute winds. Thus a sudden fall of rain or snow, at any particular spot, may *there* so increase the weight of the air, as to make it weigh up all the surrounding air: high winds will be the result, having on the earth's *surface* a direction *from* the spot where condensation has thus taken place.

314. We have shown it to be possible that the air which surrounds us may be a heavy fluid exercising great pressure upon the surfaces of our bodies, attended by all the phenomena observable in other cases of fluid pressure, and yet we ourselves be altogether unconscious of that pressure. We may be living in a fluid at the bottom of an ocean, as we see fish to be living in the sea, receiving large quantities of it at every instant into our bodies, and exhaling it, as we observe a current of water to pass through the gills of fishes, and yet perceive but few of its properties, scarcely even be made aware of its existence. And accordingly, philosophers reasoned and speculated for two thousand years on the subject of the atmosphere before they discovered that it was *material, a fluid, and had weight*. This is easily explained, there are no *direct* observations which lead us to the conclusion that air has weight. There is, indeed, little or nothing in the phenomena which establish that conclusion, to guide us to the connexion between those phenomena and the question of atmospheric pressure. A link is wanting. The theory of hydrostatic pressure establishes that link. Thus, a man ignorant of the principles of hydrostatics can perceive no relation between the ascent of water in a tube by suction and the weight of the external air. But let him acquire a knowledge of the principle *that a heavy fluid cannot rest until the pressure upon every point in the same horizontal plane is the same*, and this connexion will at once establish itself in his mind.

Thus it was that philosophers endeavoured in vain, for some 2000 years, to account for the ascent of fluids by suction, until, hopeless of a solution, they pronounced it to be an *anomaly*—a freak of Nature—an unaccountable antipathy, which she had taken to an empty space. They asserted, for instance, that when the air was removed from a tube, one end of which was immersed in water, Nature, *abhorrent* of a vacuum, thrust the water immediately into it, to fill up the vacant space; and that she did this, notwithstanding the opposite tendency of the water to descend by reason of its weight.

It having, however, happened to some engineers at Florence to discover that water could not be raised in a pump, suck out the air as much as you would, above the height of thirty-two feet, this principle of the *utter* abhorrence of Nature for a vacuum was found to require some qualification; and its limits were accordingly fixed by Galileo, at a height of thirty-two feet.

315. One Torricelli, a pupil of Galileo, doubting the explanation of his master, reasoned upon the question somewhat in this way. Since by the absolute removal of the air above it, a column of water can be supported at the height of thirty-two feet, and no higher, it would seem that the force whatever it may be which supports it, should be precisely equal to the weight of such a column; and that, therefore, that force would not probably have supported so high a column, had the liquid been some other, heavier than water, so that the abhorrence of Nature would not in the case of a heavier liquid extend so high as thirty-two feet. He tried mercury; and he found that, however perfect the vacuum made above its surface, it would not stand at above twenty-eight or thirty inches. This column of mercury, he then ascertained to be precisely of the same weight, with a column of thirty-two feet of water, of the same diameter.

Hence, therefore, it became apparent to him, that the cause, whatever it was, was subject to this law, that it should always develope a force equal to the weight of the liquid supported, whatever that liquid might be. This abhorrence of Nature for a vacuum was therefore no freak, but like every other development of her energies in unorganized matter, the subject of a fixed and invariable law. Reasoning further upon his experiment, and applying to it certain principles of hydrostatics, which had by that time become known, he at length perceived its connexion with the external pressure and weight of the atmosphere, arrived at its true explanation, and constructed



## THE BAROMETER,

by which we are enabled to *measure* at any time the exact pressure of the atmosphere upon a given surface at the place where we make our observations; and which, whether we consider it in reference to the importance and accuracy of its indications, or the remarkable simplicity of its construction, deserves to be ranked among the most valuable of our instruments.

316. The Barometer is thus constructed: a glass tube  $BH$ , somewhat more than thirty inches in length, of which one end is closed, is filled with mercury; and the finger being then applied to the open end, so as to prevent the escape of any portion of the mercury, the tube is inverted in a cup of mercury  $CD$ , the open end being plunged beneath its surface; the finger is then withdrawn, and a free communication left between the mercury in the tube and that in the cup. The former is immediately perceived to descend, until it finally takes up a position of equilibrium; somewhere between twenty-eight and thirty inches above the level of the mercury in the cup.

Now let us consider the circumstances under which this equilibrium takes place. It has been shown (Art. 251), to be a necessary condition of the equilibrium of a continuous fluid, that the pressure upon every equal area in the *same horizontal plane*, any where taken in it, shall be the *same*. Thus then, taking that horizontal plane  $EF$  which passes through the lower extremity  $B$  of the tube, it follows that the pressure upon every equal portion of that plane is the same. Hence, therefore, the pressure upon that area or portion of the plane which lies immediately under the bore of the tube, is the same with the pressure upon an equal area elsewhere. The pressures upon these areas are respectively equal to the weights of columns of the



fluids in which they are contained, continued vertically upwards from those areas, respectively, to the free surfaces of these fluids. (Art. 252.) Now the space  $GH$  being a vacuum, the free surface of the fluid in the tube is at  $G$ . But *without* the tube, in order to arrive at the free surface of the fluid, we must continue our column, *through* the mercury, to the extreme limits of the atmosphere.

Hence, therefore, it follows, that the column  $BG$ , within the tube, is equal in weight to any other column without it, having an equal base in the same horizontal plane  $FE$ , and reaching, through the mercury, to the top of the atmosphere. This last column is composed partly of the column of atmosphere spoken of, and partly of a column of mercury of the same dimensions with  $AB$ , and having, therefore, the same weight with it. Taking, therefore, from each of the above-mentioned equals, the weight of the column,  $AB$  it follows, that the weight of the column  $AG$  in the tube, above the surface of the mercury in the cup, is equal to the weight of a column of the atmosphere of equal base, continued to the very surface of the atmosphere. Thus then, by means of this simple little instrument, the Barometer, not more than thirty-one inches in length, we measure the precise weight of a column of the atmosphere reaching to its very surface, a distance certainly not less than fifty or sixty miles.

It was thus that Torricelli explained the suspension of the mercury in his tube; and he confirmed the conclusion which he had arrived at, by causing his barometer to be carried to a great elevation above the earth's surface, the top of the Puy de Dôme, near Auvergne; it was found that the mercury sunk there considerably beneath the level at which it had stood in the plain below. This was a necessary consequence of the theory: for by carrying the instrument to the top of the mountain, the height of the superincumbent column had been considerably diminished; and since the suspended column of mercury could not rest until it had the same weight with such a column of atmosphere, it must necessarily descend, as the column of atmosphere was thus diminished\*.

Thus, at the top of Mount St. Bernard, the barometer stands at only fourteen inches, whilst at the level of the sea its usual height is twenty-eight inches.

\* If every equal portion of the atmospheric column were of the same weight, by whatever fraction, in his ascent, the observer diminished the height of that portion of this column which was above him; by the same fraction only would he find the whole height of the column of mercury in his barometer to be *diminished*; and thus, supposing the height of the atmosphere to be fifty miles, a barometer carried to the height of five miles (which is probably greater than any height to which it could be carried,) would sink only by one-tenth of its whole height, or about three inches.

The atmospheric column is not, however, throughout of the same weight; its lower portions are greatly heavier than the higher; and thus it happens that ascending through only a small fraction of its whole height, as for instance at the top of Mount St. Bernard, we nevertheless get through the heaviest portion of it; so as to diminish the weight of the superincumbent column, and consequently the height of the barometer, more than one-half.

317. The barometer has since been applied on this principle to the determination of the heights of mountains. By methods which it does not consist with the elementary character of this work to explain, the precise elevation above the earth's surface, corresponding to each height of the column of mercury in the tube, may be calculated. Thus, then, carrying a barometer with us to the top of a mountain, and observing the height at which the mercury stands in it, we may know, the requisite calculations having been made, exactly what is the height of the mountain. Formulæ are given, and tables have been constructed, which very greatly facilitate this calculation.

The determination of heights by the barometer is certainly the most simple and easy method known, and it is probably the most accurate. In order, however, to obtain this accuracy, numerous precautions must be taken. In the first place, the precise height of the column above the surface of the mercury in the cup must be ascertained. This is no easy matter. It is clear that a scale of inches and parts, fixed as it usually is, by the side of the tube, and numbered from the surface of the fluid in the cup *upwards*, will not serve us to effect this measurement with accuracy. For the surface of the mercury in the cup necessarily varies its position continually, as more or less of it is contained in the tube; if, therefore, at one height of the column, the zero, or first division of the scale, coincided with the surface of the mercury in the cup, it could not possibly do so at any other.

Various methods have been contrived to remedy this inconvenience. Among the best, probably, is the following. The cup of mercury is constructed accurately in the form of a cylinder, as shown in the figure. Its bottom, which is turned accurately to fit the internal surface of this cylinder, admits of having a slow motion communicated to it by means of a screw, so as to raise or depress the whole mass of mercury above it in the cup. There is an ivory index with a fine point turned downwards, which is fixed precisely on the level of the first division of the scale. When the instrument is to be used, the screw\* spoken of is to be turned until the surface of the mer-

\* The contrivance of a moveable bottom to the cup seems to be in a great measure unnecessary; any thing by which a portion of the fluid might be displaced, would serve equally well to elevate its surface. We might, for instance, simply insert a screw into the side of the cup near its bottom; as this screw was moved further *into* the cup, or *out of it*, the surface of the mercury would be raised or depressed.

cury in the cup is brought just to touch the ivory point. This being accomplished, the height shown by the scale is accurately that of the top of the column above the surface of the mercury in the cup.

318. Not only does a variation take place in the height of the mercury in the barometer when it is *moved* to different elevations above the earth's surface, but also when it is kept in the same position, there are scarcely any two periods of time when its height is accurately the same; and this is not only the case when the air is in motion, but also at periods when it is apparently at rest. The heights of the barometer are perceived under these circumstances to be different at different times of the day, and at different periods of the year. From the careful comparison of a great number of observations made in the Royal Observatory at Paris, the following general conclusions have been drawn by M. Bouvard.

Dividing the day into two periods, the first extending from nine in the morning to three in the afternoon, and the second from three in the afternoon to nine at night; it will be found that during both these periods the barometer *falls*; but that the quantity by which it falls during the *first* period is much greater than that by which it falls during the *second*. In respect to the *first* period, a considerable regularity is apparent in the variations of the barometer, as well from year to year, as from one month to another. From an average of eleven years, it appears that the mean annual descent of the barometer between nine in the morning and three in the afternoon, is  $\cdot 02976$  inches.

By a comparison of the variations of the *first* period from month to month, the following remarkable fact was established: that during the three months of November, December, and January, these variations were greatly less than during the other months of the year; and that they were greatest during the months of February, March, and April. The variations during the remaining six months of the year were intermediate between these, but apparently subject to no law. In respect to the variations of the *second* period, no law could be traced; they were usually less than one-half those of the preceding period.

By a comparison of the diurnal variation of the barometer at different places on the earth's surface it appears, that it is at all places between the tropics nearly the same, and that it is there the greatest; that it rapidly diminishes as the latitude increases, and is not perceptible in latitude  $74^{\circ}$  north.

It has been observed, that the diurnal variations of the baro-

meter are subject to the influence of the wind; that they are scarcely perceptible during the prevalence of winds from the south, and attain their maximum when the wind is from the north.

319. The weight of the suspended mercurial column always equalling that of a column of the atmosphere, it follows that a variation of the former can only take place when there is a corresponding variation in the latter. These variations in the weight of the superincumbent column of atmosphere at any place are supposed to indicate changes in the weather; an opinion which has, it is said, of late received a remarkable confirmation from the discovery made by Professor Dove, of Berlin, of a direct relation between the height of the barometer and the hygrometrical state of the atmosphere. The difference between the greatest and the least heights of the barometer does not exceed three inches.

It is customary to observe it, as indicating changes in the weather with considerable accuracy. In order to preserve the tube from injury the whole of it, excepting the three inches within which the variation takes place, is inclosed in a tube of brass, to which is fixed a scale whose divisions extend only along the three inches of which we have spoken. Annexed to certain of these divisions may be seen the words Fair, Rain, &c., specifying the description of weather which is supposed to be indicated by the corresponding heights of the mercury.

The only indications of the barometer which can be relied upon as connected with the state of the weather, are its *changes*. The following rules are said to be founded in observation.

1. A *rising* of the barometer indicates the approach of fine weather; a *falling*, shows the approach of foul weather.

2. In sultry weather, the fall of the barometer indicates thunder. In winter, the rise of the mercury shows frost. In frost, its fall indicates thaw; and its rise indicates snow.

3. Whatever change in the weather *suddenly* follows a change in the barometer may be expected to last but a short time. Thus, if fair weather follow immediately the rise of the mercury, there will be very little of it; and, in the same way, if foul weather follow a sudden fall of the barometer, it will last but a short time.

4. If fair weather continue for several days, during which the mercury continually falls, a long succession of foul weather will probably ensue: and again, if foul weather continue for several days, while the mercury continually rises, a long succession of fine weather will probably succeed.

5. A fluctuating and unsettled state in the mercurial column indicates changeable weather.

6. There is another rule which is founded upon the principles of Hydrodynamics, and which may, therefore, be taken as nearly, if not absolutely true; it is this: That a low state of the barometer indicates the prevalence of high winds, somewhere not very remote from the place of observation.

320. A column of mercury having a base of one square inch, and a height of thirty inches, weighs about fifteen pounds. Now, supposing the barometer to stand at thirty inches, the pressure of the atmosphere will just be sufficient to support such a column, and will, therefore, just equal its weight. Under such circumstances, then, the atmospheric pressure is just fifteen pounds on each square inch of surface. Thus taking the surface of a man's body to contain somewhere about 2000 square inches, it follows that the whole pressure of the surrounding air upon it is of the enormous amount of 30,000 pounds.

321. In the use of the barometer, considerable difficulty arises from the extreme smallness of the variations in the height of the mercury corresponding to each change in the atmospheric pressures. The whole space through which this variation takes place, corresponding to the extreme cases of the density and rarefaction of the air at the earth's surface has been stated to be three inches. It is, therefore, manifest that the intermediate states, of which there is an infinite variety, sensibly different from one another, can be indicated only by minute fractions of an inch in the variation of the height of the column. To obviate this difficulty, various forms of the barometer have been contrived.

322. Of these, one of the simplest and most ingenious is called the

#### DIAGONAL BAROMETER.

It is simply a barometer of which the tube is bent, as represented in the accompanying figure, somewhat below the lowest point to which the mercury can sink. This tube being filled, like the common barometer, with mercury, whose surface rests at some point *q* in the bent portion of the tube *ABC*, every variation in the density of the atmosphere will be found to be indicated by a much more considerable motion of the mercury along the tube than though the tube were straight.

This is very easily explained. The pressure upon the base

## WHEEL BAROMETER.

c of the column, is not equal to the weight of the whole bent column  $qbc$ , but to what would be the weight of the column  $bc$  if it were continued in the same vertical direction to the level  $pq$  of the surface  $q$ . Thus it is equal to the weight of the column of mercury which would fill the tube  $pc$ . If, therefore, the column of atmosphere alter its weight by any quantity, say by a quantity equal in weight to a column of mercury reaching from  $p$  to  $p'$ , so that its weight now becomes equal to that of the column  $cp'$ , then is the surface of the mercury in  $ab$  on the same level with  $p'$ , or at  $q'$ ; it has, therefore, moved through the space  $qq'$ , which is greater than  $pp'$ , and may be made as much greater than it, as we choose, by increasing the inclination of  $ab$ . Thus the

motion of the surface of the mercury along the tube  $ab$  for any given variation in the weight of the atmosphere, is much greater than it would have been in the straight barometer.

323. Another contrivance for effecting the same object is the

## WHEEL BAROMETER.

$ABF$  represents a barometer-tube bent at  $B$ , so that both the branches  $AB$  and  $FB$  are vertical. This tube is filled with mercury, and inverted in the position shown in the figure. It is manifest that the mercury will rest when the pressure of the atmosphere upon the surface  $E$  is equal to the weight of the column of mercury  $FK$ , which stands in the other branch of the tube above the level of  $E$ . Now any descent of the surface  $E$  will produce an equal ascent of surface  $F$ ; and the surface  $E$  being depressed, and  $F$  elevated by the same quantity, the distance of these two surfaces, or the difference of their levels, will be increased by double that quantity. Hence, therefore, the variation of the column  $FK$  is double that of the position of the surface  $E$ . But  $FK$  is the height of the barometer, that column being equal in weight to the corresponding column of atmosphere. The variation in the position of  $E$  is, therefore, half the variation in the height of the barometer.

To measure the variation in the position of  $E$ , the following method is adopted. A small iron ball is made to

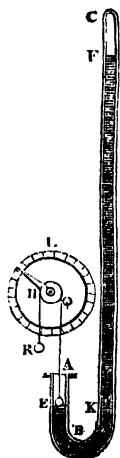
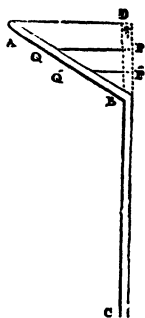

float\* on the surface of the mercury. To this ball is attached a string which passes over the circumference of a wheel or pulley at  $q$ , and carries at its other extremity a weight  $r$ , which is less than the weight of the iron ball. The wheel  $q$  carries an index  $n$  pointing to the equal divisions of a larger circle  $l$ .

It is clear that, by the descent of the surface  $e$ , the iron ball becoming immersed to a *less* depth in the fluid, will be less supported by it (Art. 282) than before, and since when so supported it was just balanced by the weight  $r$ , the equilibrium will now be destroyed, the iron ball will descend, and the string carry with it the circumference of the circle and the index. By the distance moved over by this index the actual descent of the surface of the mercury may easily be ascertained.

Suppose, for instance, the circumference of the wheel  $q$  to be one inch and a half; a descent of the surface  $e$ , through one inch and a half, causing the string to move through that distance, will produce a *complete* revolution of the circle and its index. If, therefore, we divide the circumference of the outer circle into 300 equal parts, a motion of the index over any one of these parts will indicate a motion of the surface  $e$  through the 300th part of an inch and a half, or through the 200th part of an inch. But this motion of the surface  $e$  corresponds to double that variation of the barometer—that is, it corresponds to a barometric variation of the 100th part of an inch. So light a variation as this may be therefore readily perceived by means of a wheel barometer. There are, however, numerous causes of error introduced by the mechanical part of the arrangement; and the instrument has no pretensions to the accuracy of the simple barometer.

The *actual* height of the column  $kr$  is somewhat influenced by the weight of the iron ball at  $e$ . The *variations* in its height, for observing which this instrument is principally used, are, however, unaffected by it.

The wheel barometer is the instrument commonly known under the name of the weather-glass. Particular positions of the index are supposed to be connected with particular states of the weather, and the names of these are annexed to the corresponding divisions of the circle. These indications of the weather, rank in authority with the predictions of the almanacks. It is not in any known positions of the index, but in the changes of its positions, that it really sympathizes with the state of the weather.

\* A mass of iron plunged in mercury displaces a volume of it whose weight exceeds its own weight. Iron, therefore, *floats* in mercury.



## THE SIPHON.

324. THE Siphon is another instrument of exceeding simplicity; its application is not, however, like that of the barometer, to the purposes of science, but to the commonest uses and occasions of life. By means of this instrument a fluid may

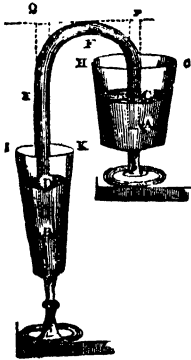

be made to ascend, apparently of its own accord, out of the vessel which contains it, to pass over the edge of that vessel, and then to descend and empty itself into another adjacent vessel; all that is required is that the level of the fluid in the second vessel shall be beneath that in the first.

The bent tube  $\Delta F B$  represented in the accompanying figure constitutes a siphon. It is, in the first place, filled with fluid, the open ends being stopped; one of them  $A$  is then plunged in the fluid of the vessel  $C II$  which is to be emptied, and the other passes into that  $I K$  which is to be filled. The two extremities of the tube

being then opened, the fluid is immediately found to flow from one into the other.

The reason of this will easily be understood. The pressure of the fluid within the branch of the tube  $F A$  upon its lowest section  $A$ , tending to cause it to flow *out* of the tube, is equal to the weight of a column  $A P$  reaching from  $A$  to the level of the *highest* portion of the tube; also the pressure of the external fluid at  $A$  tending to cause it to flow *into* the tube, is equal to the weight of a column of the height  $A C$ , together with that of a superincumbent column of air; hence, therefore, on the whole, the fluid is pressed at  $A$ , inwards, by the weight of a superincumbent column of atmosphere, diminished by the weight of the column of fluid  $C P$ . Similarly it may be shown that at  $B$  the fluid is pressed into the tube, by the weight of a superincumbent column of the atmosphere diminished by the weight of the column of fluid  $D Q$ . So long, then, as the column  $D Q$  is greater than the column  $C P$ , the fluid is pressed into the extremity  $A$  of the tube with greater force than it is pressed into the extremity  $B$ . It is, therefore, made, by these unequal pressures, to move through the tube in the direction  $A F B$ , until the surface  $C$  comes on the same level with  $D$ .

The pressures at  $A$  and  $B$ , tending, both of them, to force the

fluid *into* the tube, keep its parts together, causing them to form one continuous column. That continuity will, however, be broken, when the column  $CP$  is more than thirty inches in height, if the fluid be mercury, and when it is more than thirty-four feet in height, if the fluid be water. For if  $CP$  exceed those limits, under the circumstances supposed, its weight will *exceed* that of a superincumbent column of air; and, therefore, by what has been said above, it appears that the aggregate pressure upon the section at  $A$ , will not be *into* but *out* of the siphon. Much more, then, will its tendency at  $B$  be *out* of the siphon, since  $QB$  is greater than  $PA$ . Since, then, the fluid tends to flow out of the siphon at both ends, the column will separate, and the siphon will cease to act. Thus a siphon cannot be made to raise water more than thirty-four feet, or mercury more than thirty inches; or to raise it at all in a vacuum.

After filling the siphon, we have supposed *both* of its extremities to be stopped before they are plunged beneath the surfaces of the fluid in the two vessels. It is manifestly only necessary to stop one of them; the atmospheric pressure being sufficient, under those circumstances, to support the column in the other branch, even when it is inverted.

In the siphons commonly used in drawing off spirits, there is a cock supplied for thus stopping one extremity of the siphon; and it may thus be kept continually full.

325. The Wurtemberg Siphon is another, and still more simple contrivance, for thus keeping the tube full and ready for use. It is composed of two branches which are precisely alike, and which are *turned up* at their extremities; the pressures upon the surfaces of the fluid in the small portions of the tube, thus turned up at the extremities of its two branches, are, when the branches are held in a vertical position, precisely the same. The fluid, therefore, remains at rest in the tube. When, however, one of the extremities is immersed in a fluid, the surface of which is above the level of the fluid in the other branch of the tube, the inequality spoken of before is immediately reproduced, and the fluid flows through the siphon. The theory of this is precisely the same with that of the simple form of the siphon.

## CHAPTER II.

327 Elasticity of the Air proved by experiment.	333 The Exhausting Syringe.
329 Elasticity proportional to Density.	336 The Air Pump.
330 The Condenser.	337 Experiment with Air Pump.
331 The Gauge.	341 Suction Pump.
332 The Air Gun.	342 Lifting Pump.
	343 Forcing Pump.
	346 Fire Engine.

## ON THE ELASTICITY OF AIR.

326. THOSE properties of fluids which we have hitherto discussed, result exclusively from their fluidity, and are, therefore, common to all of them. Fluids are, however, of two kinds; these are, *inelastic* fluids or liquids, and *elastic* fluids or gases. To the latter class belongs the atmosphere, and although it partakes, as we have stated before, in all those properties which have been shown to belong to other fluids, and all the resulting phenomena are common to it and them, yet there is another class of phenomena resulting from its fluidity which are peculiar to it, and of equal, if not superior importance, to the former.

All those atmospheric phenomena which we have hitherto discussed would, in point of fact, occur precisely as they do, if the air which surrounds us had been a liquid like water, instead of a highly elastic and expansive fluid, as we know it to be. It is our present object to treat of those further properties which result from its elasticity.

327. We may thus, by a very conclusive experiment, convince ourselves of the elasticity of the air. The accompanying figure represents a bent glass tube  $ABC$ , at one extremity  $c$  of which is fixed a stop-cock. The stop-cock being opened, and a small quantity of mercury  $EBE'$  poured into the tube, it will be found to stand at the same level  $EE'$  in both of the branches; the atmospheric pressure at  $E$  and  $E'$  being the same; and those portions of a fluid of which equal surfaces sustain equal pressures, being necessarily in the same horizontal plane (Art. 251.)

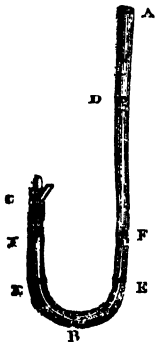

Now let the stop-cock  $c$  be closed. It will be found that by the stopping of the cock, although the pressure of the *superincumbent* column of atmosphere, on that contained in

the portion of the tube  $EC$ , is taken off, yet will the resistance of this air to the upward tendency of the surface  $E$  (arising out of the atmospheric pressure upon  $E'$ ,) remain unaltered; for  $E$  will not move. Now this would occur, exactly in the same way, if the fluid contained in  $EC$  were a liquid like water, or even a solid; but let us pour more mercury into the branch  $AB$  of the tube, and we shall at once perceive a difference between the two cases. Suppose that when additional mercury has been poured into the tube  $AB$ , its surface is at  $D$ ; the pressure upon  $E$  will now be increased by the weight of the column  $DE'$ . Now if  $EC$  had contained a liquid, this additional pressure, however great it might have been, would have produced no motion of the surface  $E$ : the liquid supplying, always, an increased resistance, precisely equal to the increased pressure. But  $CE$  containing air, it will be found incapable of supplying this increased resistance in its present state; it will immediately yield to the increased pressure, the surface  $E$  will ascend, and the fluid in  $EC$  will not be found to have acquired a power of resistance adequate to this new demand upon it, until the space it occupies has been considerably diminished. Now there is a remarkable relation between this increased power of resistance and the diminution of volume under which it is attained. It is this; the proportion in which the volume of the fluid is diminished is precisely that in which its power of resistance is increased. Thus, if the volume be diminished one-half, the resisting power is doubled; if the fluid be contracted into one-third its bulk, its power of resistance is tripled; and so on.

Thus, as in the experiment above described, more mercury is poured into the tube  $AB$ , thereby increasing the pressure upon the surface  $E$ , it will be found that that surface will continually *ascend*, compressing the air above it; and when this compression has thus been continued until the space  $EC$  is diminished one-half, or to  $FC$ , it will be found that the mercury rests at such a height in the other arm  $AB$  as to *double* the pressure upon the surface  $E$ . Also the surface  $E$  *rests* at  $F$ . The fluid in  $FC$  supplies, therefore, a resistance double of its former resistance; or its *power of resistance is doubled*. Now the pressure upon  $E$  we know to be doubled when the height of the column  $DE'$  between the levels of the two surfaces, equals the height at which the barometer stands at the time of the experiment. For before the *additional* mercury was poured into the tube, the pressure upon  $E$  was that of the atmosphere, and, therefore, equalled the weight of the barometric column; and

now it is increased by the weight of  $DF'$ ; if, therefore, the weight of  $DF'$  equal that of the barometric column, it is *doubled*.

Similarly, by making the column  $F'D$  three times the barometric column, we may *triple* the pressure upon  $E$ , the space  $ED$  will then be found to be diminished to one-third of its former dimensions, and so on.

Hence, therefore, it follows, on the whole, that the volume of any given portion of air is diminished as the pressure upon it is increased; and that this relation of the pressure and volume is governed by the remarkable law that the increase of the pressure is exactly proportional to the diminution of the volume.

328. Now the converse of all this is also true; that is to say, the volume of any given portion of air is *increased*, as the pressure upon it is diminished; and the diminution of pressure is precisely equal to the increase of volume. To prove this, let the stop-cock be opened, and a portion of the mercury used in the last experiment having been poured out of the tube, let it be inverted, the cock having been first closed. The pressure upon  $E$  will now no longer be increased, but diminished by the weight of the column  $E'D$ ; and the pressure upon  $E$  being thus diminished, that surface will be found to move in an opposite direction to its former motion along the tube, the air in  $EC$  now expanding itself so as to occupy a greater space in the tube;



also, if the quantity of mercury in the tube be so adjusted as to cause the air in  $EC$ , thus to *double* the space which it occupied before, it will be found that the length of the column is now such as to cause the pressure upon  $E$  to be just half what it was before. That is, the surface  $E$  will have moved to a point  $F$ , such that the length of the column  $F'D$  will be just half the height of the barometric column. Similarly, if the quantity of mercury contained in the tube be such as to cause the space  $CF$  to be tripled, the distance  $F'D$  between the levels of its two surfaces, will be found to be two-thirds of the barometric column, showing the pressure upon  $F$  to have been diminished to one-third, and so on. Hence, therefore, it follows that as we diminish the pressure upon any mass of air,

it expands its bulk, and that the diminution of pressure is exactly proportional to the increase of bulk.

That force by which air thus expands itself, and resists pressure applied to it under these conditions, is called its **ELASTICITY**.

Generally, then, the elasticity of any portion of air is increased as its volume is diminished; and the contrary.

329. The density of air is the quantity of it contained in a given space. Now, as the *volume* of any given quantity of air is *diminished*, the *quantity* of it contained in a given space, say one cubical inch, is *increased*. And this diminution and increase are in *exact* proportion. Hence, therefore, it follows that the elasticity of air increases exactly in the same proportion as its density increases, and *vice versâ*.

These properties of the air by which it may be compressed into a smaller space or expanded over a *greater*, enter largely into the explanation of that infinite variety of atmospherical phenomena which are daily occurring around us; they have, further, suggested the construction of some of the most valuable and useful instruments which science has supplied to the arts. We shall proceed to describe some of these.

#### THE CONDENSER,

330. Is an instrument for forcing into a certain space a greater bulk of air than would, under the ordinary pressure of the atmosphere, be contained in that space. A section of an instrument of this kind is represented in the accompanying figure. EF is a hollow cylinder, A is a solid circular mass of metal which accurately fits the interior surface of the cylinder, and may be moved freely along it.

The bottom of the cylinder communicates with the vessel D, called the receiver, into which the air is required to be compressed. Over the small aperture by which this tube communicates with the receiver, is fixed, loosely, a piece of oiled silk extending a considerable distance beyond the edges of that aperture. This piece of silk is called a silk valve, and its operation will shortly be explained. The piston A is pierced by a small channel whose under surface is also covered by a silk valve, similar to that at c.

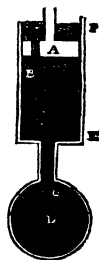

Now suppose the piston A to be driven down; the air underneath it will then be compressed, the force necessary to retain it under compression will, therefore, be increased (Art. 329), and will now exceed the elasticity of the air in D; the silk valve loosely covering the aperture c will, therefore, be pressed unequally above and below, and will be driven away; the

compressed air in the cylinder thus finding its way into the receiver.

Whilst the air is thus allowed to pass freely from the cylinder through the aperture *c* it will be observed that its escape through *B* is rendered impossible. The elastic force of the air compressed beneath the piston instead of removing the obstacle opposed by the valve which covers *B* will only tend, by pressing its edges against the under surface of the piston, to fix it more across that aperture. Hence, therefore, it appears that when the piston has *completed* its descent, the whole of the air before contained in the cylinder will have been forced into the receiver. When the piston is drawn back, if the valve *c* *remained* open and *B* closed, the pressure being again diminished, as it was before increased, this air would, by the properties we have stated in a preceding article (Art. 328), again expand itself over the space it before occupied, returning from the receiver into the cylinder; and things would thus resume the state in which they were before the piston was first put in motion. Such is, however, not the case; when the pressure upon the piston is in the slightest degree diminished, it becomes insufficient to retain the expansive power of the condensed air in the receiver; the pressure upon the valve *c* again becomes unequal, but that from *beneath*, instead of that from *above*, has now the preponderance. The result is that the edges of the silk are pressed tightly against the inner surface of the receiver, and it becomes an airtight covering firmly fixed across the aperture. Thus the return of the air from the receiver into the cylinder is rendered impossible. Again, after the piston has been drawn up a very short distance, that small portion of compressed air which was contained in the upper portion of the tube which joins the piston and receiver, and in the small space which may have intervened between the piston and bottom of the cylinder, becomes expanded over so large a space that its elasticity is less than that of the atmosphere without the condenser. The valve *B'* will, therefore, be now pressed *downwards* with a greater force than it is pressed *upwards*. It will, therefore, be thrust *from* the aperture, and the air from *without* will find its way into the cylinder, and will thus *ease* the ascent of the piston.

When the piston has been drawn to its highest point, and the cylinder beneath become filled with air, the operation may be repeated; and thus successive volumes of air, each equal to the content of the cylinder, may be compressed into the receiver; thereby continually increasing its density, and in the same proportion, its ELASTICITY (Art. 329.)

It is desirable to have some instrument by means of which the degree of elasticity thus communicated to it may be measured. Such an instrument may readily be supplied. It is called

#### A GAUGE.

331.  $ABD$  is a bent glass tube, having a stop-cock at  $A$ , and being made to communicate through the branch  $A$  with the interior of the receiver. A small quantity of mercury is contained in the portion  $BCF$  of the tube  $BCD$ . The stop-cock  $A$  being open before the condensation, the surfaces  $B$  and  $F$  will stand at the same level, and will retain this level after the cock is closed again, so long as the density, and, therefore, the elasticity of the air in the receiver is the same with that of the external air, or that in the branch  $CD$  which is the same with it. So soon, however, as the air in the receiver becomes denser, and, therefore, more elastic (Art. 329) than that in  $FD$ , the equality of the pressures upon the two surfaces  $B$  and  $F$  will be destroyed; the surface  $F$  will be made to ascend, until the *increased* elasticity of the air thus *compressed* in the space  $FD$ , together with the weight of that portion of the column  $CF$  which is above the level of  $B$ , equals the elastic force of the air in  $AB$ , or in the receiver.

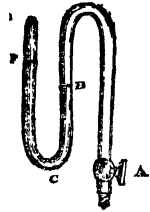

Observing the height at which the surface  $F$  is thus made to stand, we may readily calculate what is the elasticity of the condensed air. Thus if  $F$  stand at such a height as to have compressed the air above into half its original space, we know that its elasticity must have been doubled, and, therefore, that it must have become equal to the weight of a mercurial column twice the height of the barometer, and deducting from this height the difference between the levels of  $B$  and  $F$ , (which is twice the elevation of the latter surface, or the depression of the former,) we know that the remainder is the height of a column of mercury whose weight equals the pressure at  $B$ , or the elasticity of the air in the receiver.

The gauge might be so graduated that these results should at once be given by inspection.

#### THE AIR GUN,

332. Is, as its name indicates, a gun from which bullets may be projected by means of condensed air. A strong spherical receiver is constructed, which admits of being screwed upon



the breech of the gun, and also upon the extremity of a condensing syringe. By the action of this syringe a large quantity of air is condensed into it, and it is then unscrewed and fixed upon the gun. Connected with the receiver, when thus applied to the gun, is a contrivance for opening a valve by means of a trigger, and thereby producing a communication between the interior of the receiver and that of the barrel of the gun. Through this channel, when opened, the air rushes with great force, carrying with it whatever missiles may have been placed there. There is a very simple mechanism by which, after each discharge, a new bullet may be instantaneously slipped into the barrel of the gun, and the discharge repeated.

The force with which missiles may thus be propelled has manifestly no other limit than the degree of condensation which can be produced, and the *strength* of the receiver. The strongest form for the receiver is that of a sphere, that being the form under which a given volume is contained with the least possible surface.

#### THE EXHAUSTING SYRINGE.

333. IF instead of the valves *e* and *c*, described in the condensing syringe, *opening* downwards and *closing* upwards, they had *closed* downwards and *opened* upwards, as shown in the annexed figure; the instrument, instead of a *condensing* would have become an *exhausting* syringe.

Its action will readily be understood. Suppose the piston to be at the bottom of the cylinder; and let it be raised; the air beneath it will then be *expanded*; its elasticity will thus be diminished, and rendered less than that of the external air. The pressure upon the valve *e* from *without* will thus be rendered greater than that from *within*; it will, therefore, be tightly closed, and prevent the entrance of the air through the aperture which it covers. Again, the air in the cylinder being rendered rarer than that in the receiver *A*, the pressure upon the valve *c* from below will be made to exceed that from above, and it will be opened, the air in the receiver passing through it into the cylinder, and thus *expanding* itself. When the piston has thus completed its ascent, the air in *A* will have been expanded over the

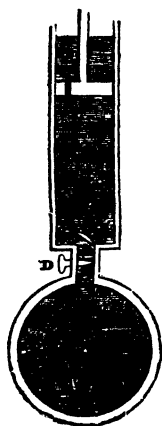

whole of the interior both of the receiver and the cylinder. Thus, if the cylinder equal the receiver, the elasticity and density will each have been diminished one-half.

Let now the piston be made again to descend. Immediately that the space beneath it in the cylinder is diminished, the elasticity of the contained air will be increased, and will be made to exceed that in the receiver; the valve *c* will, therefore, now be pressed downwards with a greater force than it is pressed upwards, and consequently it will be tightly closed, and the air in it will remain in that expanded or rarefied state to which it was brought at the instant when the piston was at its greatest height. As the descent of the piston is continued, the air beneath it will gradually become more and more condensed, until at length it attains again the same density, and, therefore, elasticity, with the external air. When this is the case, the valve *e* will be pressed equally from without and within; as, however, the condensation is continued, by the still further descent of the piston, this equality will cease, the pressure from beneath will exceed that from above; the valve will open, and the air will escape, and thus the piston will be allowed to descend freely to the very bottom of the cylinder; when the operation of exhaustion may be repeated by causing it to ascend a second time, and thus we may *theoretically* continue the rarefaction of the air in the receiver without any limit. *Practically*, however, there is a limit opposed to this continual exhaustion, by the weights of the valves.

334. It is clear that in order to lift either valve, the pressure from beneath must exceed that from above by a quantity greater than the weight of the valve. Now, when the exhaustion has been carried on to a very great degree, it *may* become, and practically *does* become, impossible to bring the piston so closely in contact with the bottom of the cylinder as to render the elasticity of the air beneath it by this means greater than, or even equal to, that of the *external* air.

There is a similar source of error arising from the weight of the valve *c*. Thus, if there be *any weight* at all in the valves, a limit is affixed to the possible exhaustion, and that limit is more remote as this weight is less. The great points to be attended to in the construction of an exhausting syringe are, therefore, as will appear from what has been stated above, that the weights of the valves should be the least possible, and that when the piston is at its *lowest* point, the space which can be occupied by the air beneath it may also be the least possible.

335. There are numerous contrivances for getting rid of

these difficulties, and extending the limits to which exhaustion may be carried. Of these, one of the best is, probably, that by which we are enabled to do without one of the valves *c, e*.

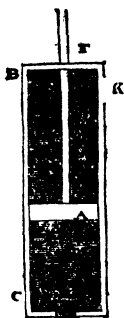

The contrivance by which this is effected, will be understood by an inspection of the accompanying diagram. The piston *A* is here *solid*. The top *F* of the cylinder is closed, and the piston-rod moves in it through an air-tight collar. An aperture *K* supplies a communication between the upper part of the cylinder and the receiver, and in the bottom of the cylinder is a valve *opening downwards*.

Suppose the piston to be at the *bottom* of the cylinder and to be forced up, a vacuum will thus be produced beneath it, or between the under surface of the piston and the bottom of the cylinder, the valve *E* being closed by the pressure of the external air; the ascent of the piston having been continued until it has passed the aperture *K*, a communication will be formed through the aperture between this vacuum and the air contained in the receiver, and thus the latter will be expanded over the space which it occupied before together with that portion of the cylinder through which the piston has passed, which when it has descended to the bottom, will be the *whole* cylinder. The piston being then made again to descend, the communication between the air now contained beneath it in the cylinder and the receiver, will, when it has passed the aperture *K*, be cut off, and the density of the air in the space *AC* will continually increase, until at length it surpasses that of the external air; the valve *E* in the bottom of the cylinder will then open, and the air beneath the piston will escape. This operation may be repeated, an additional degree of exhaustion being produced at every stroke of the piston *E*, until as before, the rarefaction is so great that the air contained in the cylinder after the piston has ascended, being compressed by its descent into that small space which cannot fail to exist between its under surface and the bottom of the cylinder, is yet not of sufficient elasticity to force down the valve. This difficulty is sometimes in a measure removed by placing *upon* this valve a receiver connected with *another* exhausting syringe, by which a portion of the atmospheric pressure upon the under surface of the valve may be removed. The solid piston is certainly, in every point of view, a great improvement on that commonly used.

In the first place, the exhaustion may be rendered more rapid by the use of two cylinders instead of one. In the next place we may communicate motion to the piston so as to cause the force we apply to act at a mechanical advantage, and lastly, we may produce the exhaustion in a receiver capable of being moved, so that the apparatus of any experiment which we may wish to make *in vacuo*, may readily be introduced beneath it.

The following figure represents the section of a machine containing all these properties, and called an

AIR PUMP.

336. B and B' are two cylinders, the tops of which are closed, except that they admit the piston-rods FE and F'E' through air-tight collars.

P and P' are solid pistons moveable in these cylinders, to which they are fitted with great accuracy, so as in every portion to be air-tight. The rods of these pistons terminate in racks EF and E'F' which are applied on either side of the circumference of a cog-wheel w, moveable by means of a hand-winch H' w. At the bottoms of the cylinders are small apertures closed by valves v and v', which open downwards. Near their upper extremities they communicate, by means of orifices o and o' in their sides, with a system of tubes TTT' forming a communication with the receiver R. This receiver is commonly of glass, its shape is that of a cylinder with a curved top terminating by a ball of glass, which answers the purpose of a handle. Its lower portion is open, so as to form a sort of

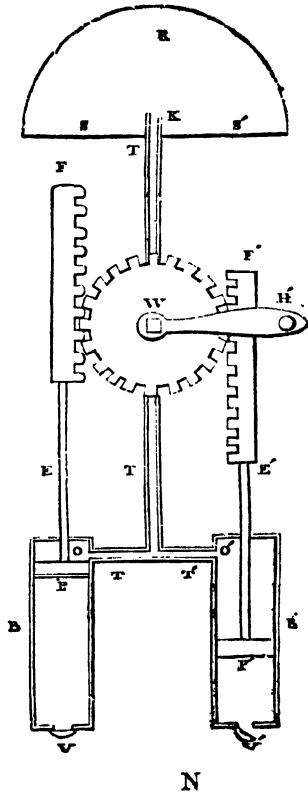

mouth, of which the edges are ground so as to be perfectly smooth, and in the same plane. This receiver rests upon a horizontal plate,  $ss'$ , of brass, whose surface is also ground with great care so as to be accurately a plane. If the edges of the receiver and the surface of the plate be thus ground so as to be very accurately in the same plane, their contact will be airtight. The accuracy of the contact may be increased by smearing tallow on the ground edge of the receiver.

These precautions being taken; let us suppose the wheel to be turned, one of the pistons  $p$  will then be made to ascend, and the other to descend. By the ascent of  $p$  a vacuum will be produced in the cylinder beneath it; the valve  $v$  being closed by the pressure of the external air. When  $p$  has passed the aperture  $o$ , the air in the receiver will be made to communicate with this vacuum; and thus to expand itself over the cylinder  $B$ , in addition to the space which it before occupied. The piston  $p'$  will, in the mean time, have been forced to the bottom of the cylinder  $B'$  in which it moves. Let the wheel then be turned in a direction opposite to its former motion. The operation of exhaustion will now be performed by the piston  $p'$  as it was before by  $p$ , and, by turning the wheel thus continually backwards and forwards, it may be carried on, until the whole of the rarefied air contained in either cylinder, being, when the piston is forced to the bottom of it, condensed into the small space between the bottom of the piston, the bottom of the cylinder, and the surface of the valve, has not sufficient elasticity to open the valve or overcome the pressure of the external air, although the tendency of the elasticity to overcome that pressure is *here* increased by the weight of the valve. It is by this circumstance, that a limit is placed to the exhausting power of the air pump. There is an ingenious modification of it by Cuthbertson, in which the opening and shutting of the valves is effected not by the condensation and rarefaction of the included air, but mechanically by the motion of the piston; by this contrivance the limit of exhaustion is somewhat further removed.

The figure on the next page represents an Air Pump constructed on the principles we have described *in perspective*. All the parts of the instrument are represented in this drawing.

$HL$  is the gauge; it is merely a glass tube, of which the upper extremity communicates with the receiver, and the lower is plunged in a cup of mercury. When the air in the receiver is rarefied, its elastic force being diminished, that portion of the surface of the mercury in the cup which is *within* the tube

sustains less pressure than that *without* it. The equilibrium is, therefore, destroyed (Art. 251), and the mercury ascends in the tube until the requisite equality of pressure is restored; the weight of the suspended column of mercury and the elastic

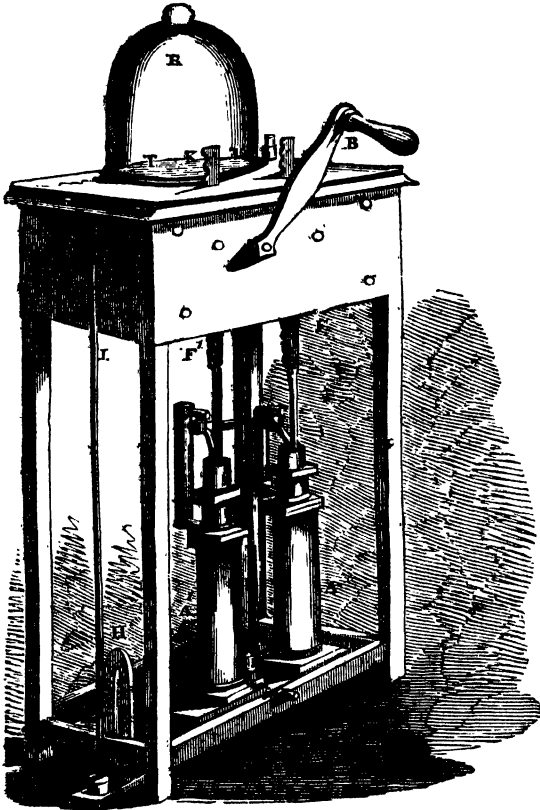

pressure of the air above it now equalling the pressure of the air without; that is, equalling the weight of the barometric column. Hence, therefore, it follows, that if we diminish the height of the barometric column by the height of the column of mercury suspended in the tube, the remainder will be the height of a mercurial column which would be sustained by the elasticity of the air in the receiver.

## EXPERIMENTS WITH THE AIR PUMP.

337. THE state in which every thing around us exists, and the manner in which every action is carried on, are more or less influenced by the fact of our constant immersion in the atmosphere. To become perfectly conscious of this, we have only to remove the air by means of the machine which we have just been describing, and observe the state in which the same bodies exist, and the same things occur, *in vacuo*.

338. Thus a vessel which appears to us empty, is in reality filled with a heavy fluid; and when we weigh it, supposing ourselves only to weigh the empty vessel, we weigh also the fluid which it contains.

To convince ourselves of this, we have only to extract the air from it, which, if it be in the form of a bottle the neck of which is provided with a stop-cock, we may readily do, by screwing this neck to the orifice  $\kappa$  of the air pump, and extracting the air as from the receiver. If after this exhaustion, the bottle be again weighed, it will be found to be considerably lighter than before. Again, the air presses upon every portion of the sides of a vessel, and yet does not crush it, however fragile the material out of which it is constructed may be, simply because it occupies the inside of the vessel as well as the outside, and presses it outwards from within, with the same force that it presses it inwards from without.

339. To render this evident, let two hollow hemispheres, such as those represented in the figure, have their edges accurately ground, and fitted to one another so as when pressed together to render them air-tight. Let a tube communicate with one of these, and admit of being screwed upon the orifice  $\kappa$  of the air pump. Let the air then be taken from within the space enclosed by the hemispheres, and it will be found that although before the air was thus extracted, they admitted of being separated by the slightest force applied to them, yet now the pressure of the external air being counterbalanced by no *internal* pressure, it will hold the two together so firmly, that supposing the diameter of the sphere be six inches, a weight of four hundred pounds will not be found sufficient to separate them. This is the celebrated experiment of the Madgeburg Hemispheres, and is one of the earliest made with the air pump. Otto Guericke, the inventor of that instrument,



constructed a pair of hemispheres one foot in diameter, requiring a force of 1700 pounds to separate them. If the hemispheres when exhausted, be removed from the orifice *x* of the pump, a stop-cock in the tube having been first closed, so as to prevent the return of the air into the space which they enclose, and if they be then laid on the plate *TT'* of the pump and the glass receiver placed over them; then by working the pump, and thus removing the air from the outside as well as the inside of the hemispheres, we shall very soon cause them again of their own accord to fall asunder.

340. Not only, however, is the air a heavy fluid, but it is an elastic fluid, and tends perpetually to expand itself, and thus to burst asunder any vessel in which it may be confined. We are altogether unconscious of such a tendency, and perceive none of its effects, because the outward pressure of the air upon the vessel is just equal to this elastic tendency of the contained air, and neutralizes it. To assure ourselves, however, of the fact, we have only to take a phial containing nothing but air, and cork it firmly, fixing down the cork by wire, or otherwise, and rendering it air-tight, and place this phial of air underneath the receiver of the air pump; as long as it is surrounded by the air in the receiver, its tendency to burst the sides of the phial will not be apparent, but as soon as this is removed, it will take effect, and the phial will be broken to atoms.

#### THE SUCTION PUMP.

341. A SECTION of the Common Suction Pump is represented in the accompanying figure.

*ABD* is a cylinder called the barrel, in which a piston *A* is moveable by means of a piston-rod *AL*, connected, above, with the extremity of a lever called the brake or pump-handle. In the piston is a valve opening upwards as in the exhausting syringe; to which, indeed, the whole apparatus bears a close resemblance both in form and principle. *E* is a second valve closing the bottom of the barrel, and opening upwards. From the bottom of the barrel a tube *ED*, called the suction-tube, passes into the well or other reservoir from which water is to be raised.

Suppose the barrel and tube to contain nothing but air, and let the piston *A* be put in motion. It is evident, that on the prin-

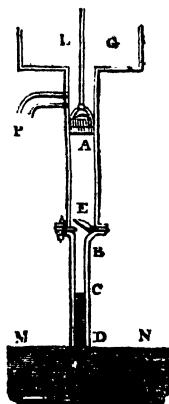



ciple of the syringe, a portion of the air will at each stroke be exhausted from the tube  $BD$ . The elasticity of the air over the surface of that portion of the water of the well which is *within* the tube, will then become less than that *without* it. The equilibrium, which requires the pressure on the same horizontal plane to be the *same*, will therefore be destroyed, and the water will ascend in the tube, until by its weight, and the increased elasticity of the air above it, now reduced into a less space, the equality of pressure in the same plane is restored, and it finally rests at some point  $P$  of the suction-tube. Another stroke of the piston will produce a still further exhaustion, and again destroy the equality of the pressure upon equal portions of the plane  $MDN$ , within and without the tube; the result will be a still further elevation of the water, until at length it is brought to the *top* of the tube, and passes into the barrel.

Here a new operation of the pump takes place; on the descent of the piston, the valve  $E$  closes, and the fluid is retained in the barrel beneath it, occupying a portion of the space  $AE$ , until, the piston continuing to descend, it is at length plunged into the fluid, and the latter is made to pass through the valve in it. It now occupies a portion of the barrel *above* the piston. And by the next ascent of the piston, it is raised with it to the level of the spout  $P$ , by which it is discharged; the space beneath the piston filling continually with water as it ascends, and this water passing to its upper surface at its next descent, to be then discharged as before.

If a perfect vacuum were formed by the action of the piston above the surface of the water in the suction-tube; it could not be raised to the top of it, and so into the barrel, provided that the tube were more than thirty-four feet in length. For it is raised by the pressure of the air on the surface of the water in the well, and that pressure would, in our country, support a column of mercury of only from twenty-eight to thirty inches in length; now such a column is equal in weight to one of somewhere about thirty-four feet of water. In reality, however, however perfectly the piston and barrel may be constructed, they will not produce a vacuum; and no pump is so constructed as to raise water so much as thirty feet. When it is raised from a greater depth, as in mines, a series of pumps are used. These each discharge the water into a reservoir, from which it is taken by the next above it in the series.

#### THE LIFTING PUMP.

342.  $AB$  represents an open cylinder immersed vertically

in the reservoir from which water is to be raised. *c b* is a pipe communicating with this cylinder through which the water is to be raised; at *B*, where these unite, is a valve, opening upwards. In the cylinder a water-tight piston *A* is made to move by the intervention of a frame *D E F G* to which the piston-rod *A H* is fixed. In the piston is a valve *A*, opening upwards.

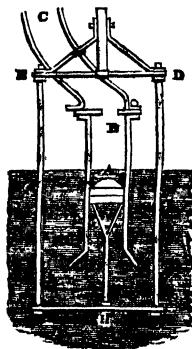

The way in which this pump works is easily seen; by the ascent of the piston the fluid above it in the cylinder is forced from it through the valve at *B*, into the pipe *c*. As the piston descends the water upon its inferior surface, pressed by the external air, from which pressure the water upon its superior surface is free, raises its valve, and the water rushes above it into the superior part of the cylinder, whilst the return of the water from the forcing-tube *c b* is prevented, by the closing of the valve at *B*. The next ascent of the piston will thus take place under the same circumstances as the first.

The force necessary to move the piston is manifestly (Art. 252) equal to the weight of a vertical column of water of the same area with itself, reaching from it to the height to which it is raised.

### THE FORCING PUMP.

343. THIS pump presents a combination of the suction and lifting pumps; it raises water from a reservoir *below* its own level, on the principle of the suction pump, and then raises it to any height above that level, on the principle of the lifting pump.

*B F* is a suction tube passing into the reservoir from which water is to be raised. *A B* is a vertical cylinder in which there works a solid piston *A*. Between this cylinder and the suction tube is a valve *B*, opening upwards; and from the side of the cylinder there passes a branch tube *c d*, through which the water is to be forced to the higher level, and which contains the valve *c*.

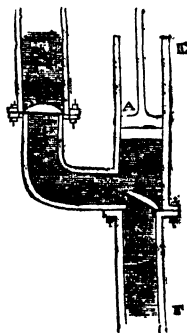

To understand the action of this pump let the suction tube *B F* at first be supposed to contain only air, and let the piston be made to ascend; the air underneath it in the space *B*, and in the branch tube *d c* beneath *c*, will then be *expanded*; and, its

elasticity becoming less than that of the external air, the valve *c* will be tightly closed, and the fluid will ascend in the suction tube.

As the piston descends again, the valve *B* will close, and when the air in *c D B* has acquired, by the contraction of the space in which it is contained, a density, and, therefore, an elasticity, greater than that of the external air, the valve *c* will be raised, a portion of air will be expelled, and the next ascent will, therefore, produce a still further rarefaction and ascent of the water in the suction tube, until at length it will find its way through the valve *B* and into the space *c D B*. When this is once the case, the *descent* of the piston will force the water from the cylinder *A B* into the tube *c D*, and each future ascent will bring more water into the cylinder, to be, like the last, forced into the tube *c D*, through its valve *c*, and to the level at which the forcing-tube terminates. It is only at the *descent* of the piston that water is made to ascend through the forcing-tube. The flow of the water through that tube is, therefore, *intermittent*.

344. There is a very ingenious contrivance by which it may be made to flow *continually*, although not always with the same force. The arrangement of the suction tube, cylinder, piston, &c., are precisely as before, but the branch forcing-tube *c K* is made to communicate immediately with an air-tight reservoir, in the top of which is inserted the pipe through which the water is ultimately to be raised, and which passes nearly to the bottom of the reservoir. The water being *forced*, by the action of the pump, into this reservoir, compresses the air in the space above its surface, and thus renders it more elastic than the external air. Hence the pressure upon that portion of the surface of the fluid which is *within* the pipe becomes less than that on an equal portion *without* it. The equilibrium is, therefore, destroyed (Art. 251), and the water made to ascend in the tube. And by continually forcing more water into the reservoir the compression of the air in it may be carried to any extent, and, consequently, its elasticity and the elevation of the water in the tube.

Now the compressed air in the reservoir will tend to expand itself *incessantly*, and not only at the moment when it is undergoing compression by influx of the water from the cylinder of the pump; thus water will be made *continually* to flow through the forcing tube. On this principle is constructed

#### THE FIRE ENGINE.

345. A SECTION of this engine is shown in the figure. It

consists of two forcing pumps A D, B E, whose pistons A, B, are worked alternately by the same lever, to whose extremities their rods are attached. These forcing pumps communicate with the same air vessel H, from which there passes a metal tube I K, terminated by a flexible tube of leather, or hose, as it is termed. By the intervention of this tube the water forced into the air vessel by the pumps, and continually pressed from thence into the tube, by the elasticity of the air compressed

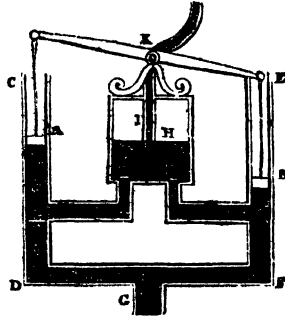

above it, is applied in spots remote from the engine itself, and at considerable distance above the level at which it acts. The great objection to the use of a reservoir of the kind described above, called an air vessel, is this, that by reason of the great force by which the air is pressed upon the water, it is made to be *absorbed* by it, so that the air, by degrees, passes away from the reservoir with the water, and the latter is *filled* with water.

346. There is a very ingenious pump which gives a continued stream without the aid of the air vessel, and is, therefore, free from the objection we have just stated.

The solid piston A works in a cylinder which communicates with a system of tubes such as is represented in the figure. D is the suction tube, and c the tube through which water is to be forced. There are valves at P, Q, R, S, opening as shown by the figure. Suppose the whole filled with water, and let the piston be in the act of ascending; *underneath* it the pressure will be diminished, and above it increased; the valves at s and q will, therefore, close, and the valves P and R open. The atmospheric pressure will cause water to *ascend* through the suction tube, and by the valve P into the cylinder beneath the piston; whilst the water above the piston will, at the same time, be *forced* through the valve R up the tube c.

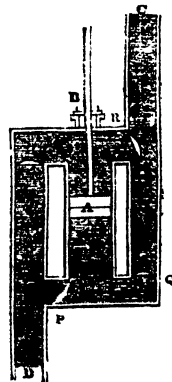

On the descent of the piston again, the valves R and P will close, and s and q will open. The tendency of the piston to produce a vacuum *above* it will now, as before, cause the water to ascend through the

suction tube, but its direction will not now be through the valve *s*, but up the tube *D s*, along *s B*, and into the cylinder *above* the piston. Again, the water beneath the piston will be driven downwards and along the channel *P Q*, through the valve *q*, up the channel *Q R*, and so into the forcing tube. Thus the pump will, at one and the same instant, and at every instant, act as a forcing and a lifting pump, and the water will flow from it *continually*, and always with the same force. This is a very beautiful contrivance.

## APPENDIX.

THE first ten propositions of this Appendix contain the Mathematical Demonstration of the following Statical Principles.—1. The Parallelogram of Forces.—2. The Equality of Moments.—3. The Theory of Parallel Forces.

The principle of the parallelogram of forces is that on which the whole science of Statics has in the preceding pages been made to depend. It is clearly its legitimate basis, inasmuch as it establishes that relation of *unequal* forces which is necessary to their equilibrium in the simplest case under which the equilibrium of unequal forces is possible, *viz.*, that of three forces acting upon a point.

The principle of the parallelogram of forces is easily demonstrated *experimentally*. We have, therefore, found no difficulty in laying it down as a *first principle* in an inquiry into the general conditions of equilibrium professing to be founded *upon experiment*. In respect, however, to a theoretical investigation of the theory of Statics, the case is very different.

The direct investigation of the principle of the parallelogram of forces on mathematical principles offers difficulties which would probably at the very outset discourage a large portion of those readers for whose instruction this work is especially intended, and to whom some knowledge of the *mathematical principles* of Statics will be found of the greatest practical value.

Under these circumstances it is judged expedient not to commence the following mathematical investigation of the theory of Statics, with a demonstration of the parallelogram of forces, but to arrive at the demonstration of that principle through the medium of the subordinate demonstration of the equilibrium of three parallel forces acting upon a rigid body, anywhere in the same plane; which case of equilibrium would in the proper order of investigation, be made to depend upon the preceding case.

## PROPOSITION I.

THE resultant of two parallel forces acting upon a rigid body, passes through a point between them, about which their moments (Art. 35) are equal.

Let  $P$  and  $P'$  represent any two parallel forces acting upon the points  $P$  and  $P'$  of a rigid body. Now the position of the

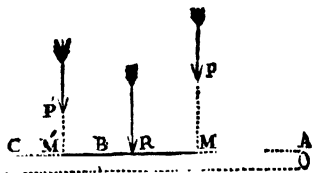

resultant of the forces  $P$  and  $P'$  in reference to either of them, manifestly is the same in whatever direction those forces may be applied, provided they remain at the same distance, and be always parallel to one another. Suppose them, then, to

be turned round, so as to be in a *vertical* direction; draw any line  $MM'$  perpendicular to the directions of both forces, and meeting them in  $M$  and  $M'$ .

Now the forces  $P$  and  $P'$  produce the same effect as though they were applied at  $M$  and  $M'$  (Art. 3). Suppose them to be applied at those points.

Again, whatever the forces  $P$  and  $P'$  may be, two *weights* may be taken *equivalent* to them. Let two such weights be taken, and let them be formed into two *uniform* rods  $AB$  and  $BC$  precisely of the same thickness throughout, and of such lengths that being suspended at  $M$  and  $M'$  from their middle points, their adjacent extremities shall *meet* in  $B$ .

The rods  $AB$  and  $BC$  being suspended from their *middle points*, will clearly hang in a *horizontal* position, for there is no reason why either should incline more to one side than the other. The line  $ABC$  is, therefore, a horizontal *straight* line.

Now it has been shown (Art. 159) that whatever conditions of equilibrium obtain in a rigid and continuous system, the same must obtain in the equilibrium of the same system when its form is made to admit of variation; together with such other conditions as arise out of the nature of the variation to which it is subjected, and *conversely*.

Hence, therefore, whatever conditions would exist if the two rods  $AB$  and  $BC$  were joined at  $B$ , so as to form one continuous rod, exist also now that they are separate.

Now if  $AB$  and  $BC$  formed one continuous rod, the resultant of their weights would manifestly pass through the middle

point  $R$  of that rod, since the rod would balance on its middle point. Hence, therefore, it follows, that also in the present *separate* state of the two rods, the resultant of their weights passes through the point  $R$ , which is the bisection of the line  $AC$ .

Now if we divide the weight of  $AB$  by the number of units in its length, we shall get the weight of each unit. But the weight of  $AB$  equals the force  $P$ ,

$$\therefore \frac{P}{AB} = \text{weight of each unit of } AB;$$

$$\text{similarly } \frac{P'}{BC} = \text{weight of each unit of } BC.$$

But the rods are both of the same thickness; therefore, each unit of the one is of the same weight with each unit of the other.

$$\therefore \frac{P}{AB} = \frac{P'}{BC}$$

$$\therefore P \times BC = P' \times AB.$$

$$\text{Now } RC = \frac{1}{2} AC.$$

$$\text{Also } MM' = \frac{1}{2} AC.$$

$$\therefore RC = MM';$$

$\therefore$  taking away  $RM'$  from both,

$$MR = M'C = \frac{1}{2} BC;$$

and similarly,

$$RA = MM';$$

and taking away  $RM$  from both

$$M'R = AM = \frac{1}{2} AB;$$

$$\therefore 2MR = BC,$$

$$\text{and } 2M'R = AB;$$

$$\therefore P \times 2MR = P' \times 2M'R;$$

$$\therefore P \times MR = P' \times M'R.$$

That is, the point  $R$ , through which the resultant of the two forces  $P$  and  $P'$  passes, is such that the moments of these forces about that point are equal (see Art. 45).

The above proof applies to every possible case of parallel forces.

### PROPOSITION 2.

THE resultant of two forces, whose directions are oblique to one another, passes through a point between them about which their moments are equal.

Let  $P$  and  $Q$  be any two forces, acting obliquely in the same plane. Their resultant  $R$  passes through a point  $S$  about which their moments are equal. From  $S$  draw the perpendiculars  $SN$



and  $SM$  upon the directions of  $P$  and  $Q$ ; and take  $SN'$  in the same straight line with  $SM$ , and equal to  $SN$ . At  $N'$  apply the forces  $Q'$  and  $Q''$  in opposite directions, perpendicular to  $SN'$  and equal to one another. These equal and opposite forces will not in any way alter the conditions of the equilibrium of the forces  $P$  and  $Q$ , and the direction of their resultant will remain as before (see note, page 43).

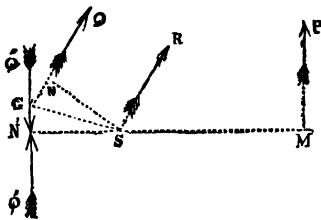

Now the forces  $P, Q, R, Q', Q''$  being in equilibrium, it is evident that the resultant of  $Q, Q''$  and  $R$  passes through the same point with the resultant of  $P$  and  $Q'$ . But the resultant of  $Q, Q''$  and  $R$  manifestly passes through  $S$ . For the two first  $Q$  and  $Q''$  are equal; their resultant bisects, therefore, the angle at which they intersect; but a line bisecting this angle passes through  $S$ ; the resultant of  $Q$  and  $Q''$  passes, therefore, through  $S$ ; and  $R$  passes through  $S$ ; therefore the resultant of  $Q, Q''$  and  $R$  passes through  $S$ .

From the above, then, it follows that the resultant of the parallel forces  $Q'$  and  $P$  passes through  $S$ . By the last proposition, therefore,

$$P \times SM = Q' \times SN';$$

but  $Q' = Q$  and  $SN' = SN$ ,

$$\therefore P \times SM = Q \times SN.$$

Therefore the moments of the forces  $P$  and  $Q$  about  $S$  are equal.

PROPOSITION 3.

If in the direction of the resultant of any two forces  $P$  and  $Q$ , acting upon a point  $R$ , we take any point  $S$ , and complete a parallelogram  $PEQS$ , of which  $SR$  is the diagonal, then  $PR$  and  $QR$  are, to one another, in the same ratio as the forces  $P$  and  $Q$ . For

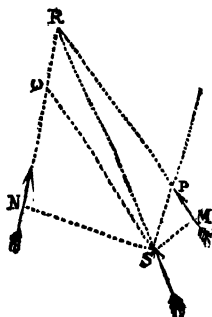

$$\therefore \frac{\Delta SPR}{\Delta SQR};$$

$$\therefore PR \times SM = QR \times SN;$$

but by last prop.  $P \times SM = Q \times SN$ ,

$$\therefore \text{dividing the equations } \frac{PR}{P} = \frac{QR}{Q}$$

$$\therefore \frac{P}{Q} = \frac{PR}{QR}.$$

That is,  $PR$  and  $QR$  are in the ratio of the forces  $P$  and  $Q$ .

#### PROPOSITION 4.

THE *converse* of the last proposition is manifestly true. That is, if  $PR$  and  $QR$  be taken in the ratio of the forces  $P$  and  $Q$ , and a parallelogram  $PSQR$  completed, then its diagonal  $SR$  will be in the direction of the resultant of the forces  $P$  and  $Q$ .

#### PROPOSITION 5.

Not only is the resultant of  $P$  and  $Q$  represented in *direction* by  $SR$ , but also in *magnitude*.

For complete the parallelogram  $SRP'Q$ , of which  $RQ$  is the diagonal and  $SR$  one of the sides. Substitute for the force  $P'$  supposed to act in the direction  $RP$ , another equal force  $P'$  acting in  $P'R$ . The equilibrium will then manifestly remain under the same circumstances as before.

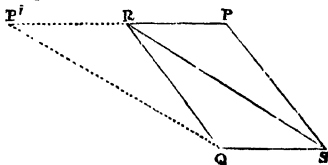

Thus, then, the forces  $P'$  and  $Q$ , together with the resultant  $R$ , which acts in the direction  $RS$ , are in equilibrium.  $Q$  is, therefore, the resultant of  $P'$  and  $R$ . And  $RQ$  is the diagonal of the parallelogram  $SRP'Q$ ; therefore, by Prop. 3,  $P'R$  and  $SR$  are proportional to  $P'$  and  $R$ ; or, in other words, on whatever scale  $P'$  is represented in magnitude by  $PR$ , on the same scale  $R$  will be represented by  $RS$ . But  $P'R$  is equal to  $SQ$ —that is, to  $PR$ ; it represents, therefore,  $P'$  in magnitude on the same scale on which  $RP$  represents  $P$ . On the same scale, therefore, on which  $P$  and  $Q$  are represented in magnitude by  $RP$  and  $RQ$ ,  $R$  is represented by  $SR$ .

#### LEMMA.

If from any point, lines be drawn to the extremities of adjacent sides, and to the extremities of the diagonal of a parallelogram, so as to form three triangles having the adjacent sides and the diagonal respectively for their bases\*; then the triangle, having the diagonal for its base, shall equal the sum

\* This lemma is true for triangles having for their bases lines anywhere situated in  $PR$ ,  $QR$  and  $SR$  produced, and respectively *equal* to those lines.

or difference of the other two, according as the point lies *within* the vertical angles formed by the adjacent sides of the parallelogram when produced either way, or *without* these angles.

Let  $PRQS$  be a parallelogram and  $o$  any point, which we will first suppose to be without the angles contained by  $PR$  and  $QR$ , or these lines produced either way.

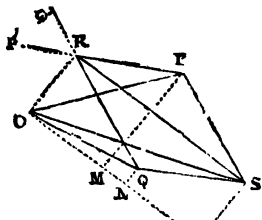

Join the point  $o$  with these points  $P$ ,  $Q$  and  $s$ . Then

$\triangle OSR = \triangle OPR + \triangle OQR$ . Join  $OR$  and draw  $OL$  perpendicular to  $OR$ , and  $PM$ ,  $QN$ ,  $SL$  each parallel to  $OR$ . Then

$$\therefore PR = QS;$$

$$\therefore OM = NL;$$

$$\therefore OL = OM + ON;$$

$$\therefore \frac{1}{2} OL \times OR = \frac{1}{2} OM \times OR + \frac{1}{2} ON \times OR;$$

$$\therefore \triangle OSR = \triangle OPR + \triangle OQR.$$

Next let the point  $o$  lie *within* one of the angles formed by  $RP$  and  $RQ$  produced. The same construction being made as before, it appears that

$$\therefore PS = RQ;$$

$$\therefore ML = ON;$$

$$\therefore LO = MO - ON;$$

$$\therefore \frac{1}{2} LO \cdot OR = \frac{1}{2} MO \cdot OR - \frac{1}{2} NO \cdot OR;$$

$$\therefore \triangle OSR = \triangle OPR - \triangle OQR^*.$$

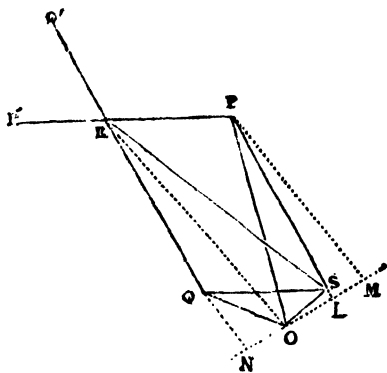

Therefore, generally, the triangle upon the diagonal equals the sum or difference of the triangles upon the sides according as the point is without or within the vertical angles formed by the sides produced either way.

If  $PR$  and  $QR$  be in the directions of two forces both acting towards or from  $R$ , it is

\* The same demonstration would have applied to the case in which  $o$  lay within the angle contained by  $PR$  and  $QR$  produced towards  $P'$  and  $Q'$ .

evident that according as  $o$  lies without or within the angles  $P R Q$  and  $P' R Q'$ , the two forces will tend to turn the system of which they form a part, in the same direction or in opposite directions about  $Q$ .

Applied, then, to the case of the parallelogram of forces, this lemma gives us the following important property.

**PROPOSITION 6.**

ANY two component forces and their resultant, being represented in magnitude and direction by lines, and any point being taken and made the common vertex of three triangles, having those lines for their bases; then the triangle, having for its base the resultant force, will equal the sum or difference of the triangles, having for their bases the component forces, according as these last act to turn the system in the same, or in opposite directions, about the point.

**PROPOSITION 7.**

THE area of each of the triangles described in the last proposition is equal to one-half the moment of the force which forms its base. It follows, then, that in the case of three forces in equilibrium, the moment of the resultant about any point is equal to the sum, or difference, of the moments of the components.

**PROPOSITION 8.**

THE moment of the resultant of any number of forces, acting in the same plane, is equal to the sum of the moments of the components; the point about which the moments are measured being any whatever, and the moments of those forces being taken negatively, which tend to turn the system in an opposite direction from the rest.

Let  $P, P_1, P_2, P_3, \&c.$  be the forces of the system, and  $o$  any point about which the moments are measured. Let  $R_1$  be the resultant of  $P$  and  $P_1$ .

- $R_2$  that of  $R_1$  and  $P_2$
- $R_3$  "  $R_2$  "  $P_3$
- $R_4$  "  $R_3$  "  $P_4$ .

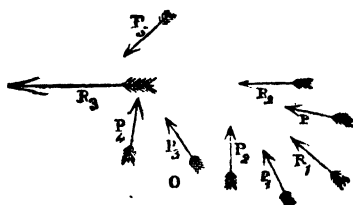

Then by the last proposition,

$$\text{moment of } R_1 = mt. P + mt. P_1^*$$

$$,, \quad R = mt. R_1 + mt. P_2$$

$$,, \quad R_3 = mt. R_2 + mt. P_3$$

$$,, \quad R_4 = mt. R_3 + mt. P_4$$

$$+ CO. = + CO.$$

$$,, \quad R_n = mt. R_{n-1} + P_n$$

Therefore adding these equations together and striking out similar terms on the two sides we get

$$\text{moment } R_n = mt. P + mt. P_1 + mt. P_2 + \dots + mt. P_n.$$

$R_n$  is manifestly the resultant of all the forces of the system. Hence, therefore, it follows that the moment of the resultant force is equal to the sum of the moments of the components, in all cases.

If the forces be in equilibrium their resultant equals nothing; the sum of their moments about any point, therefore, equals nothing.

The demonstration of this proposition applies to every possible case of forces in the same plane, and, therefore, to the case of parallel forces. But in this case the same line drawn from the point about which the moments are measured, is perpendicular to *all* the forces of the system.

Thus, in the fig. Art. 45, the line  $Mm_1$  is perpendicular to the directions of all the forces  $P_1, P_2, P_3, P_4$ . So that, in the case of parallel forces, we have only to draw a line from the point about which the moments are measured, perpendicular to any one of the forces of the system; we shall then obtain the moment of each force by multiplying it by its distance from the point measured on this line.

Also, if  $R$  be the resultant of all the forces, and it intersect the line  $Mm_1$  produced in a point which we call  $r$ , we have, by the proposition.

$$\therefore Mr = \frac{P_1 \times Mm_1 + P_2 \times Mm_2 + P_3 \times Mm_3 - P_4 \times Mm_4 - P_5 \times Mm_5}{R}$$

In which expression the moments of  $P_4$  and  $P_5$  are taken negatively, because they tend to turn the system in a contrary way from the rest.

Also, in the case of parallel forces, the resultant  $R$  is equal to the sum of the components (Art. 46); it being here also observed that those must be taken negatively, whose tendency

\* The moments of all the forces which tend to turn the system in an opposite direction are here supposed to be taken negatively.

would, when all were applied at  $x$ , be opposite to that of the rest. Thus,

$$R = P_1 + P_2 + P_3 - P_4 + \&c.$$

$$\therefore Mr = \frac{P_1 \times M m_1 + P_2 \times M m_2 + P_3 \times M m_3 - P_4 \times M m_4 - P_5 \times M m_5}{P_1 + P_2 + P_3 - P_4 - P_5.}$$

Thus, the precise direction of the resultant  $R$  of any number of parallel forces, in the same plane, may be ascertained.

We may by this means readily find the CENTRE OF GRAVITY of any number of bodies situated in the *same plane*.

For the centre of gravity is a point through which the resultant of the weights of the parts of the body passes, in whatever position it is placed.

Now, as we alter the position of the body, we alter the *directions* of the weights of its parts with respect to it, or *through* it, without altering the amount of those weights.

The case is, therefore, that of a system of parallel forces acting upon a body which alter their directions (still, however, remaining parallel,) without altering their amounts or points of application.

In this case it has been shown (Art. 51) that the resultant passes always through the *same* point. To find the position of that point we have, therefore, only to find *two* directions of the resultant; it will lie in their intersection.

### PROPOSITION 9.

THE positions of the centre of gravity of any number of heavy bodies, situated in the same plane, may be found by supposing their weights to act in any two different directions in respect to the parts of the body, and finding their resultants in the two cases. It will lie in the intersection of the resultants.

Suppose the parallel forces  $P_1, P_2, \&c.$ , to be applied at the points  $M_1, M_2, \&c.$ , in the same plane, and from any point  $o$  draw  $ox$  perpendicular to their directions. Then the direction of their resultant  $R$  may be found by the formula.

$$R = P_1 \cdot O m_1 + P_2 \cdot O m_2 + \&c.$$

Now let the directions of all the forces be turned, so as to be at right angles to their former directions. And draw  $oy$

perpendicular to  $ox$ , it will, therefore, be perpendicular to the forces in their new directions  $P_1' M_1$ ,  $P_2' M_2$ , &c.

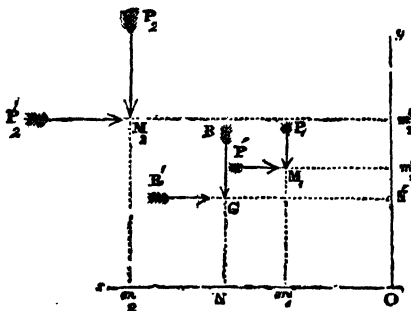

Hence the position of the resultant  $R'$ , in this direction of the forces, is determined by the formula

$$ON' = \frac{P_1 \overline{om_1'} + P_2 \overline{om_2'} + \&c.}{P_1 + P_2 + \&c.}$$

Now having thus found the values of  $ON$  and  $ON'$  we know the position of the point  $G$  where the resultants  $R$  and  $R'$  intersect. This point is the centre of gravity.

$$om_1' = M_1 m_1 \quad om_2' = M_2 m_2 \quad \&c. \quad ON' = NG,$$

$$\therefore NG = \frac{P_1 M_1 m_1 + P_2 M_2 m_2 + P_3 M_3 m_3 + \dots}{P_1 + P_2 + P_3 + \dots}$$

$$\text{similarly } N'G = \frac{P_1 M_1 m_1' + P_2 M_2 m_2' + P_3 M_3 m_3' + \dots}{P_1 + P_2 + P_3 + \dots}$$

Hence the distance  $NG$  of the centre of gravity, or any number of bodies in the same plane, from any line  $ox$  in that plane, is obtained by taking the sum of the products of all the different bodies composing the system, each multiplied by its distance from the line, and dividing that sum by the sum of the bodies themselves.

Now there is a property precisely analogous to this in respect to the centre of gravity of any number of bodies *not* in the same plane.

#### PROPOSITION 10.

**IF** there be any number of bodies, anywhere situated in space, the distance of their centre of gravity from *any*

plane is equal to the sum of the *products* obtained by multiplying each body by its distance from that plane, divided by the sum of the bodies.

Let  $P_1 P_2 P_3$  &c., be bodies anywhere situated in space, and  $y o x$  any plane. Draw through any two of the bodies  $P_1$  and  $P_2$ , and their centre of gravity  $G_1$ , perpendiculars  $P_1 p_1 P_2 p_2$ , and  $G_1 g_1$  upon the plane

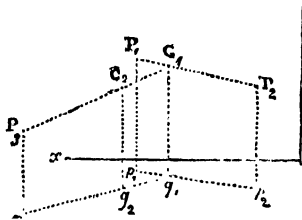

Then since  $P_1 P_2$ , and the line  $p_1, p_2$ , are in the same plane  $P_1 p_1 P_2 p_2$  it follows, by the last proposition, that

$$\overline{G_1 g_1 P_1 + P_2} = \overline{P_1 P_1 p_1 + P_2 P_2 p_2}.$$

Suppose the bodies  $P_1$  and  $P_2$  to be *collected* in their centre of gravity  $G_1$ , and find  $G_2$  the common centre of gravity of these bodies, thus collected, and  $P_3$ .

Therefore precisely as in the last case, it appears that since  $G_1$  and  $P_3$ , and the line  $g_1 p_3$ , are in the same plane,

$$\therefore \overline{G_2 g_2 \cdot P_1 + P_2 + P_3} = \overline{P_1 + P_2 \cdot G_1 g_1} = \overline{P_3 P_3 p_3}.$$

Therefore substituting from the preceding equation,

$$\overline{G_2 g_2 + P_1 + P_3} = \overline{P_1 P_1 p_1 + P_2 P_2 p_2 + P_3 P_3 p_3}.$$

And the same process of reasoning may be continued to any number of bodies; so that if  $G g$  represent the distance of the centre of the whole system from the plane  $y o x$ , then

$$G g = \frac{\overline{P_1 P_1 p_1 + P_2 P_2 p_2 + P_3 P_3 p_3 + \dots}}{P_1 + P_2 + P_3 + \dots}.$$

The plane  $y o x$  is any plane whatever. We may, therefore, by the means stated above, find the distance of the centre of gravity from each of the three planes  $y o x, z o x, x o y$ . These three distances will determine its exact position.



IF, instead of a system composed of detached bodies in the same plane, we wish to determine the centre of gravity of one continuous heavy body, all the parts of which are in the same plane, we may apply the following method.

Take any two lines  $ox$  and  $oy$  at right angles to one another, and divide one of them  $ox$  into parts  $m_1, m_2, m_3, m_4, m_5, m_6$ , equal to one another. Draw lines  $m_1 p_1, m_2 p_2, \&c.$ , dividing the figure into as many distinct parts or elements  $m_1 p_1, m_2 p_2, \&c.$  Then if the lines  $m_1 m_2, \&c.$ , be very small,  $m_1 p_1, m_2 p_2, \&c.$  may be considered as not differing, each by any appreciable quantity, from a rectangle. Each may, therefore, be considered to have its centre of gravity in the centre of its height. Bisect, therefore,  $m_1 p_1, m_2 p_2, \&c.$ , in  $g_1, g_2, \&c.$ , and these points may be considered as the respective centres of gravity of the elements. In these points, therefore, the weights of the respective elements may be supposed to be collected.

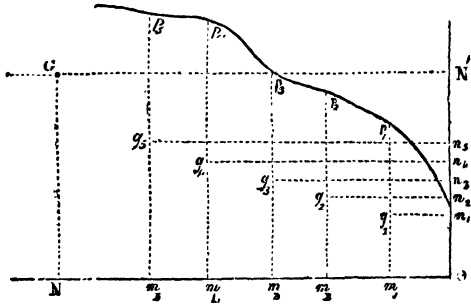

Now the masses, and, therefore, the weights of the elements, are represented by the products

$$m_1 m_2 \times p_1 m_1, m_2 m_3 \times p_2 m_2, \&c.$$

If, therefore, these weights be supposed to act perpendicular to  $ox$ , and  $G$  be the centre of gravity, we have

$$ON = \frac{m_1 m_2 p_1 m_1 \cdot OG_1 + m_2 m_3 p_2 m_2 \cdot OG_2 + \dots}{m_1 m_2 p_1 m_1 + m_2 m_3 p_2 m_2 + \dots}$$

or since  $m_1 m_2 = m_2 m_3 = m_3 m_4 = \&c.$

$$\therefore ON = \frac{p_1 m_1 \cdot OG_1 + p_2 m_2 \cdot OG_2 + \dots}{p_1 m_1 + p_2 m_2 + \dots}$$

Again, supposing the weights of the elements to act perpendicular to  $oy$ .

$$O N' = \frac{\overline{m_1 m_2 \cdot p_1 m_1} \cdot O n_1 + \overline{m_2 m_3 \cdot p_2 m_2} \cdot O n_2 + \dots}{m_1 m_2 \cdot p_1 m_1 + m_2 m_3 \cdot p_2 m_2 + \dots}$$

Whence observing that

$$\begin{aligned} O n_1 &= m_1 g_1 = \frac{1}{2} m_1 p_1 \\ O n_2 &= m_2 g_2 = \frac{1}{2} m_2 p_2, \text{ \&c.} \\ \text{also } m_1 m_2 &= m_2 m_3 = \text{\&c.} \end{aligned}$$

we obtain

$$O N' = \frac{\frac{1}{2} p_1 m_1^2 + p_2 m_2^2 + p_3 m_3^2 + \dots}{p_1 m_1 + p_2 m_2 + p_3 m_3 + \dots}$$

This last furnishes an easy practical rule for finding the centre of gravity of an *area* of any form, however irregular; and one easily recollected.

Divide it as above, into elements, by equidistant lines, called ordinates, perpendicular to a given axis. Take the sum of the squares of those ordinates, and divide it by their sum. Half the quotient will be the distance of the centre of gravity from the axis

If the forces be now supposed to act perpendicularly to any other axis at right angles to the former, the distance of the centre of gravity from *this* axis may also be found. And thus its actual position will be *ascertained*.

#### ON THE DIRECTION OF THE RESISTANCE OF A SURFACE.

(Note on Art. 72.)

LET the coefficient of friction be represented by  $f$ .

Let  $\angle P M P' = \theta$  (see fig. page 43. Art. 72.)

The force  $P M$  or  $P$  is equivalent to  $Q M$  and  $P' M$ .

$$\text{Now } Q M = P M \sin. \theta$$

$$P' M = P M \cos. \theta$$

Therefore resolved in the directions of  $Q M$  and  $P' M$ , the values of  $P$  are  $P \sin. \theta$ , and  $P \cos. \theta$ .

Now the power of resistance produced by friction is equal to the product of the coefficient of friction  $f$ , by the perpendicular force in  $P' M$ . It, therefore, equals  $f P \cos. \theta$ .

Also the force tending to move the body is the force in the direction of  $Q M$ , and equals

$$P \sin. \theta.$$

Therefore the body will move, or not, according as

$$P \sin. \theta \begin{cases} \text{is or} \\ \text{is not} \end{cases} >^{\text{er}} f P \cos. \theta,$$

or according as

$$\tan. \theta \begin{cases} \text{is or} \\ \text{is not} \end{cases} >^{\text{er}} f.$$

Let  $F$  be the angle whose tangent is  $f$ . Therefore the body will move, or not, according as

$$\tan. \theta \left\{ \begin{array}{l} \text{is or} \\ \text{is not} \end{array} \right\} > \text{er } \tan. F ;$$

or according as

$$\theta \left\{ \begin{array}{l} \text{is or} \\ \text{is not} \end{array} \right\} > \text{er } F.$$

$F$  is called the limiting angle of resistance, the body will, therefore, rest so long as the direction of  $P$  is not inclined to the vertical, at an angle greater than  $F$ .

The experimental fact that the friction is always (for the same bodies,) the same fraction of the perpendicular pressure, although a very near approximation to the true law of friction, cannot be asserted accurately to enunciate that law.

It appears, from the experiments of Mr. Rennie, that the ratio of the friction to the perpendicular pressure is somewhat greater for high, than for low, pressures. This variation from the law of friction does not, however, appear to be so considerable as to claim for itself a place in the discussion of the question until the pressure has exceeded a certain limit. Coulomb found that under pressures, varying from 400 to 1300 kilograms, the coefficient of friction for oak upon oak, varied only from  $\frac{1}{20}$  to  $\frac{1}{40}$ .

The true law of friction will, perhaps, best be expressed by considering the coefficient of friction, a function of the perpendicular pressure, which being expanded has for the coefficients of its terms after the first, exceeding small quantities.

#### THE INCLINED PLANE, (*Note on Art. 80.*)

LET the inclination of  $PQ$  to the vertical be represented by  $\theta$

LET  $\iota$  = the elevation  $CAB$  of the plane ;

$F$  = the limiting angle of resistance.

Then, when the mass  $M$  is upon the point of slipping *downwards*, since the angle which  $Gc$  makes with the perpendicular to  $Ac$  (Art. 80) equals the angle  $F$ , and that the angle which  $Gh$  makes with the perpendicular to  $Ac$ , equals  $\iota$ ; therefore the angle  $cad$ , which is, in this case, the *difference* of these angles, equals  $\iota - F$ .

Similarly, when the mass  $M$  is upon the point of slipping *upwards*, as in fig. page 49, the angle  $cad$  equals  $\iota + F$ .

Therefore, generally,

$$\angle cad = (\iota \pm F),$$

the sign  $\pm$  being taken according as the mass is supposed to be upon the point of slipping *upwards* or *downwards*.

Now in  $\triangle a b d$

$$\frac{a b}{a d} = \frac{\sin. a d b}{\sin. a b d}$$

$$\text{also } a d b = c a d = (\iota \pm F)$$

$$a b d = \pi - c a b = \pi - (\iota \pm F + \theta);$$

and also Art. 80,  $a b$  and  $a d$  represent the weights of  $M$  and  $N$ .

$$\therefore \frac{N}{M} = \frac{\sin. (\iota \pm F)}{\sin. (\iota \pm F + \theta)}.$$

$$\therefore N = M \frac{\sin. (\iota \pm F)}{\sin. (\iota \pm F + \theta)}.$$

$$\text{Also } \frac{d b}{a d} = \frac{\sin. \theta}{\sin. (\iota \pm F + \theta)}$$

And  $d b$  and  $a d$  represent the resistance  $s$  and the weight  $M$ .

$$\therefore s = \frac{M \sin. \theta}{\sin. (\iota \pm F + \theta)}.$$

If we would cause the force  $N$  to act in such a direction that it may be the least possible force which will give motion to the body; it is clear that we must take  $\theta$  so that  $\sin. (\iota \pm F + \theta)$  may be the *greatest* possible; or in other words  $\theta$  must be such that

$$\iota \pm F + \theta = \frac{\pi}{2}$$

$$\text{or } \theta = \frac{\pi}{2} - \iota \mp F.$$

The two states in which  $M$  is upon the point of slipping upwards and downwards, are said to be its two states bordering upon motion.

If we suppose the direction of the resistance to be *perpendicular* to the surface of the plane, as in the case of the carriage wheel (Art. 83), then we must, in the expressions for  $N$  and  $s$  make  $F = 0$  and we shall have

$$N = \frac{M \sin. \iota}{\sin. (\theta + \iota)}$$

$$s = \frac{M \sin. \theta}{\sin. (\theta + \iota)}$$

If the force  $N$  act in a direction parallel to the plane

$$\theta = \frac{\pi}{2} - \iota \text{ and } \theta + \iota = \frac{\pi}{2}$$

$$\therefore N = M \sin. \iota$$

$$s = M \sin. \theta.$$

## THE WEDGE.

THE following demonstration of the theory of the wedge will probably be better understood than that given in the text. (page 67.) It will further serve, at once, as an useful illustration and a verification of the principle of *least pressure*.

Let  $P$  be the force acting upon the back of the wedge,  $Q$  and  $Q'$  the *resistances* upon its sides. Now, by the principle of least pressure,  $Q$  and  $Q'$  should be the least possible subject to the condition that their resultant shall be  $P$ . It is manifest that to satisfy this condition these forces must have a direction *parallel* to the direction of  $P$ , or one inclined *as little as possible* to that direction.

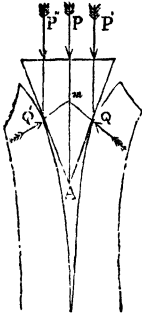

If, therefore, the surfaces in contact at  $Q$  and  $Q'$  are such as are capable of supplying resistances at those points *parallel* to  $P$ , then the system will be one of *parallel* forces, and the points  $Q$  and  $Q'$  being similarly situated with respect to  $PA$ , each will sustain one-half of the force  $P$ . But if, by reason of the *nature* of the surfaces in contact at  $Q$  and  $Q'$ , these be incapable of supplying resistance in directions parallel to  $PA$ , then will the directions of  $Q$  and  $Q'$  be those which the surfaces will supply *nearest* to the direction of  $PA$ .

Now, as is shown (Art. 72), there is a certain direction between which and the perpendicular to the surface at either point, if any force be applied, the surfaces will supply a resistance opposite to that force, but if the force be applied further from the perpendicular than this direction, then *no* equal resistance will be afforded by the surfaces in an *opposite* direction. The angle which this direction makes with the perpendicular is called the *limiting angle of resistance*. The resistances  $Q$  and  $Q'$  will manifestly have their directions inclined to  $PA$  at the *least possible* angles, when they are actually in the directions spoken of above, and make each, with the perpendicular at its point of application, an angle equal to the limiting angle of resistance. Such, then, by the principle of least pressure, are the actual directions of the pressure at  $Q$  and  $Q'$ .

Now let us consider what are the conditions of the equilibrium resulting from this conclusion.

Let  $\epsilon$  = the limiting angle of resistance,

$2\iota$  = the angle  $A$  of the wedge.

The angle which  $Q$  makes with the side of the wedge is

$$\frac{\pi}{2} - F.$$

Hence, therefore, the angle  $q m A$ , which makes it with  $P A$ , is

$$\frac{\pi}{2} - F - \iota.$$

Hence, therefore, the resolved part of  $q$  in the direction  $P A$  is

$$q \cdot \sin. (F + \iota),$$

and the wedge being symmetrical about  $P A$ , the resolved part of  $q$  is the same. Hence

$$2 q \sin. (F + \iota) = P;$$

$$\therefore q = \frac{P}{2 \sin. (F + \iota)}.$$

If  $F + \iota = \frac{\pi}{2},$

$$q = \frac{1}{2} P.$$

This is the case spoken of before, in which the directions of  $q$  and  $q'$  are parallel.

Now the above results may be arrived at by another and an entirely independent process of reasoning.

Let  $P'$  and  $P''$  each equal one-half of  $P$ , and let them be applied immediately above the points  $q$  and  $q'$ ; they may then be made to replace  $P$  without in the least altering the circumstances of the equilibrium. Now if the direction of  $P' q$  be *within* the limits of the resistance of the surfaces at  $q$ , the pressure  $P'$  will be *wholly* sustained by that resistance, and the direction of the force  $q$  will be in the same straight line with  $P' q$ ; the wedge sustaining no pressure whatever laterally or in a direction perpendicular to  $P A$ . But if the direction of  $P' q$  be *without* the limits of the resistance at  $q$ , then some other force must be supplied at  $q$ , in order to maintain the equilibrium. That force can only result from the action of the force  $P''$  at  $q'$ . It acts, therefore, in the line  $q' q$ , and, therefore, in a direction perpendicular to  $P A$ . Also, this force, resulting from the tendency of the wedge to motion on the point  $q'$ , is only just equal to that tendency, or in other words, it is equal to the least force which would keep that point at rest. Since, then, it is equal to the least force which would keep the point  $q'$  at rest, it is also equal to the least force which would keep the point  $q$  at rest: now the least force which would keep  $q$  at rest is manifestly that which will bring the direction of the resistance at  $q$  just within the limiting angle of resistance at that point. Thus, then, it appears that the directions of  $q$  and  $q'$

are inclined to the perpendiculars at those points at angles each of them equal to the limiting angle of resistance. This is precisely the result which is given us at once, by the principle of least pressure.

THE BALANCE. (*Note on Art. 103.*)

To determine the mathematical conditions of the equilibrium of the balance,

Let the weights in the scale-pans of the balance differ by the small quantity  $m$ , one being represented by  $M$  and the other by  $M + m$ .

Since, then, the resultant of these forces passes through  $\kappa$ , we have (*Art. 50,*)

$$\begin{aligned} M \cdot \overline{s\kappa} &= \overline{M+m} \cdot \overline{s'\kappa}, \\ \text{or } M \cdot \overline{s\kappa' + \kappa\kappa'} &= \overline{M+m} \cdot \overline{s'\kappa' - \kappa\kappa'}. \\ \text{Let } s\kappa' = s'\kappa' &= a; \\ \therefore M \cdot \overline{a + \kappa\kappa'} &= \overline{M+m} \cdot \overline{a - \kappa\kappa'}; \\ \therefore \overline{\kappa\kappa'} \cdot 2\overline{M+m} &= ma; \\ \therefore \overline{\kappa\kappa'} &= \frac{ma}{2\overline{M+m}}. \end{aligned}$$

Now if the inclination of  $ss'$  to the horizon equal  $\iota$  it is easily seen that,

$$Fm = \overline{\kappa\kappa'} \cos. \iota \pm F\kappa' \sin. \iota$$

The sign  $+$  or  $-$  being taken according as  $\kappa'$  is above or below  $F$ .

$$\begin{aligned} \text{Let } F\kappa' &= k, \\ \text{and } FG &= h; \end{aligned}$$

$$\therefore Fm = \frac{ma \cos. \iota}{2\overline{M+m}} \pm k \sin. \iota$$

$$\text{also } Fn = h \sin. \iota.$$

Let the weight of the beam =  $B$ ;

$$\therefore \overline{Fm} \times \overline{2M+m} = \overline{Fn} \times B;$$

$$\therefore ma \cos. \iota \pm 2\overline{M+m} k \sin. \iota = Bh \sin. \iota;$$

$$\therefore \tan. \iota = \frac{ma}{Bh \mp 2\overline{M+m} \cdot k}.$$

From this expression it appears that the deflexion  $\iota$  of the beam, produced by a given difference  $m$  in the weights contained in the scale-pans, is *greater* as the quantity

$$B h \mp \overline{2 M + m k}$$

is *less*.

Now this deflexion is a measure of the *sensibility* of the balance.

If, therefore, as in the figure, the line  $s s'$  joining the points of suspension be *above* the fulcrum, this sensibility is, the greatest where the two terms of the above expression approach most nearly to an equality. This approach to an equality may be brought about by diminishing both terms of the expression continually; for if the two quantities themselves be exceeding small, their difference must evidently be exceeding small.

For weighing, then, the same weight  $M$ , the sensibility of the balance is greater as  $k$  is *less*, and as  $B$  and  $h$ , one or both of them, are *less*. That is, we may increase the sensibility of the balance by bringing the line  $s s'$  which joins the points of suspension continually nearer to the fulcrum  $F$ , provided that at the same time we diminish continually either the weight  $B$  of the beam, or the distance  $F G$  of its centre of gravity  $G$ , from the fulcrum  $F$ .

Or whatever may be the form and magnitude of the beam, and the position of the fulcrum, we may increase the sensibility to any extent by so taking the position of the points of suspension that the difference of

$$B h \text{ and } \overline{2 M + m k}$$

may be the least possible, or  $k$  most nearly equal to

$$2 M + m.$$

The line joining the points of suspension is commonly made to pass accurately *through* the fulcrum, or only so little above it, as to allow for the deflexion of the beam. There evidently are cases where it would be advantageous to place it considerably above it.

The great practical difficulty encountered in giving extreme sensibility to the balance is this, that as we increase the sensibility of the instrument we diminish the *rapidity* of its vibrations.

#### ON THE FRICTION OF AN AXLE. (*Note on Art. 110.*)

SUPPOSE the force  $P$  to be the resultant of two other parallel forces  $Q$  and  $Q'$  acting at the extremities of a lever, or at the circumferences of two wheels having the common axis  $F E F$  shown in the figure.



Let  $CE = r$ , and let the arms of the lever be represented by  $a$  and  $a'$ . Also let

$$\angle FCE = \angle PEC = \theta.$$

Now in the case supposed  $P = q + q'$ , and the perpendicular distance from  $C$ , at which it acts, is

$$r \sin. \theta;$$

$$\therefore q \pm (q + q') r \sin. \theta = q' a';$$

$$\therefore q = q' \frac{a' \mp r \sin. \theta}{a \pm r \sin. \theta}.$$

The upper or lower sign being taken, according as  $q' a'$  or  $q a$  is the greater.

When the lever is in the state immediately bordering upon motion,  $\theta$  equals the limiting angle of friction (Art. 110.)

$$\therefore q = q' \frac{a' \mp r \sin. F}{a \pm r \sin. F}.$$

The upper or lower sign being taken according as  $q'$  or  $q$  is about to preponderate.

Let  $q_1$  be the value of  $q$ , on the hypothesis that there is no friction, or that  $F = 0$ ,

$$\therefore q_1 = \frac{q' a'}{a}$$

$$\begin{aligned} q - q_1 &= q' \frac{a' \mp r \sin. F}{a \pm r \sin. F} - q' \frac{a'}{a} \\ &= \frac{\mp q' r (a + a') \sin. F}{a (a \pm r \sin. F)}, \end{aligned}$$

which expression represents (taking the upper sign) the quantity by which  $q_1$  may be diminished without giving motion to the system; and taking the lower sign it represents the quantity by which it must be increased to give motion to it. On the whole, then, the above expression represents the *effect* of the friction of an axis.

If we suppose both the forces  $q$  and  $q'$  to act at equal distances from the axis as in the pulley,

$$q - q_1 = \frac{\mp 2 q' r \sin. F}{(a \pm r \sin. F)}.$$

In the above we have supposed the two forces tending to turn the system about its axis to be always *parallel* to one another, and at perpendicular distances  $a$  and  $a'$  from the axis. Where the forces do not remain parallel, as in the case of the *windlass*, *capstan*, &c., the formula given above, for the effect of friction, is *not applicable*.

In the case of the windlass and capstan the effect of the forces  $P$  and  $Q$  (see fig. Art. 117,) is the same as though they acted in the circumferences of two concentric circles  $A P$  and  $B Q$ , whose common centre is that of the axis  $C$ . If we suppose no friction to exist, the resultant of the forces  $P$  and  $Q$  will pass through  $C$ . Also,  $C P$  and  $C Q$  being inversely as the forces  $P$  and  $Q$ ,  $C Q$  will represent  $P$  on the same scale on which  $C P$  represents  $Q$ ; and these lines are inclined to one another precisely as they would be if they were perpendicular to the directions of the forces which they respectively represent—that is, as if  $C Q$  were perpendicular to  $P$ , and  $C P$  to  $Q$ . Hence (see note, page 109), the resultant of  $P$  and  $Q$  is represented in magnitude by  $P Q$ . To determine the direction of the resultant of  $P$  and  $Q$ , we have only to produce their directions to meet in  $R$ , and join  $C R$ . The resultant acts through both the points  $C$  and  $R$ , and, therefore, in the right line  $C R$ .

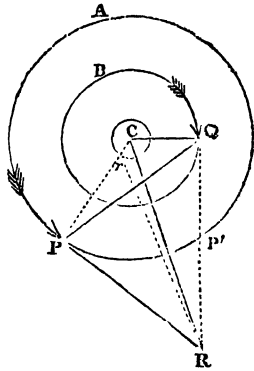

It is evident that the direction and magnitude of this resultant vary with the relative positions of  $P$  and  $Q$ . It is *greatest* when  $P C$  and  $Q C$  are in the same right line, being then equal to their sum and parallel to both of them. It is *least* when  $P$  is in the line  $Q R$  and coincides with  $P'$ . In this case it is represented in magnitude by  $P' Q$ , and equals

$$\sqrt{Q^2 - P^2}.$$

If we take into account the friction of the axis, it is evident that motion cannot ensue until the resultant  $R r$  of  $P$  and  $Q$  cuts the circumference of the axis at such a point  $r$  that the angle it makes with  $C r$  may exceed the limiting angle of resistance.

ON THE CONDITIONS OF THE EQUILIBRIUM OF TOOTHED WHEELS, TAKING INTO ACCOUNT THE FRICTION OF THE TEETH: (Note on Art. 125.)

Let  $t$  be the length of the teeth on either wheel,  $a$  and  $a'$  the radii of the wheels.

Join the points  $C$  and  $C'$  with  $Q$ . Then, when motion is about to ensue—the wheel whose centre is at  $C$  moving the other—the angle which  $Q M'$  makes, with the perpendicular

to  $c'q$ , equals the limiting angle of resistance  $F$ . But this angle also equals the angle  $q c' m'$ . Therefore, when motion is about to ensue under these circumstances,

$$c' m' = (a' + t) \cos. F.$$

If the cogs be supposed in contact at their extremities, the lengths of the lines  $cq$  and  $c'q$  are respectively  $a + t$  and  $a' + t$ ;

$$\text{also } c c' = a + a' + t.$$

Knowing the three sides  $c q$ ,  $c' q$ , and  $c c'$  of the triangle  $c c' q$ , we can find its angle  $c c' q$ . Let this be found, and let it equal  $G$ .

$$\begin{aligned} \therefore \angle c c' m' &= F - G; \\ \therefore c m + c' m' &= c c' \cos. c c' m' \\ &= (a + a' + t) \cos. (F - G); \\ \therefore c m &= (a + a' + t) \cos. (F - G) - (a' + t) \cos. F; \\ \therefore, \text{ by Art. 125, if } c' A' &= b' c A = b \\ P &= b' \frac{(a + a' + t) \cos. (F - G) - (a' + t) \cos. F}{b (a' + t) \cos. F} \cdot W \end{aligned}$$

The above expression gives the true relation between  $P$  and  $w$  in cog wheels, the friction of the wheels being taken into account, and that on the axes neglected. The expression may be put under the form

$$\begin{aligned} P &= \frac{b'}{b} \left\{ \left( 1 + \frac{a}{a' + t} \right) \frac{\cos. (F - G)}{\cos. F} - 1 \right\} W \\ &= \frac{b'}{b} \left\{ \left( 1 + \frac{a}{a' + t} \right) (\cos. G + \tan. F \sin. G.) - 1 \right\} W \end{aligned}$$

Now if the teeth be small compared with the radii of the wheels,  $G$  is exceeding small, and  $\cos. G$  may be taken  $= 1$ . Whence by reduction we get

$$P = \frac{b}{b (a' + t)} \left\{ a + (a + a' + t) \sin. G \tan. F \right\} W.$$

#### THE SCREW. (Note on Art. 133.)

It has been shown in a preceding portion of this Appendix that the conditions of the equilibrium in the wedge, or moveable inclined plane,

$$q = \frac{Q}{\sin. (F + t)}$$

where  $t$  is the inclination of the plane,  $q$  the resistance, and  $Q$  the force applied to the back of the plane parallel to its base.

Now, in the screw,  $q$  is supplied (see fig. page 106) by the action of the force  $P$  at the extremity of a lever  $PL$ .

$$\text{Let } PL = a \qquad Ln = b :$$

$$\therefore P \cdot a = q \cdot b ;$$

$$\therefore q = \frac{P a}{b \sin.(F + \iota)}$$

NOTE ON ART. 182.

THE conditions of the equilibrium of a system of bodies in contact have been *fully* discussed by the author of this work in a paper read before the *Camb. Phil. Soc.* in October, 1833, on the principles laid down in Chap. XV.; these, together with the theory of the ARCH dependent upon them, are here *published* for the first time.

The theory of the arch presents another illustration of the principle of least pressure. The pressures upon the surfaces of the abutment and key-stone should, by that principle, be each a minimum, subject to the condition that they should be sufficient to sustain the semi-arch if it formed one continuous solid, and that the pressure on the key should be *horizontal*. Now the weight of the semi-arch being given, as the pressure upon the key diminishes, that upon the abutment also diminishes. Also the pressure upon the key tending to support either semi-arch results from the tendency of the opposite semi-arch to motion, and just equals that tendency. It is, therefore, equal to the least force which would support the semi-arch; or it is a minimum, subject to the conditions, and, therefore, the pressure upon the abutment is also a minimum.

NOTE ON ART. 270.

SUPPOSING the whole surface to be divided into small parts, represented by  $P_1, P_2, P_3$  &c., and their depths by

$$P_1 p_1, P_2 p_2, \dots$$

then the sum of the products of these forces by their depths will be

$$P_1 p_1 \cdot P_1 + P_2 p_2 \cdot P_2 + \dots$$

and calling  $Gg$  the depth of the centre of gravity, the product of that depth by the whole surface will be

$$Gg \cdot P_1 + P_2 + P_3 + \dots$$

But by Proposition 10 of this Appendix,

$\overline{gg} \cdot P_1 + P_2 + P_3 + \dots = \overline{P_1 p_1} \cdot P_1 + \overline{P_2 p_2} \cdot P_2 \dots$   
 which is the principle stated in the text.

## NOTE ON ART. 295.

LET  $PQ$  and  $P'Q'$  be positions of the plane of flotation;  $PLQ$  and  $P'LQ'$  being the parts immersed, corresponding to these positions.

Let  $g$  be the centre of gravity of  $PLQ$ , and  $g'$  that of  $P'LQ'$ . Also let  $m$  be the centre of gravity of  $PaP'$ , and  $m'$  that of  $QaQ'$ . Join  $m m'$ , and through  $g$  draw  $gh$  parallel to  $m m'$ .

moment of  $P'LQ'$  about  $gh = mt. QaQ' + mt. QL P - mt. PaP'$ .

Now, moment of  $QLP$  about  $gh = 0$ , since  $g$  is in that line,

$$\therefore mt. P'LQ' = mt. QaQ' - mt. PaP'.$$

Also the centres of gravity  $m$  and  $m'$ , of  $PaP'$  and  $QaQ'$  are equidistant from  $gh$ , and the volumes  $PaP'$  and  $QaQ'$  are also equal to one another, since  $PLQ$  is equal to  $P'LQ'$ ; hence, therefore, it follows that the moments of these volumes are equal, and, therefore, that the moment of  $P'LQ'$  about  $gh$  equals 0. The centre of gravity  $g'$  of  $P'LQ'$  is, therefore, in  $gh$ .

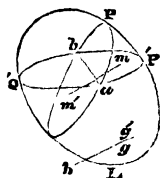

Now let the angle made by  $PQ$  and  $P'Q'$  be indefinitely diminished. The points  $g$  and  $g'$  will then approximate indefinitely to one another, and the plane in which they lie being parallel to  $m m'$  will ultimately be parallel to the plane  $PQ$  or  $P'Q'$ . But these planes are horizontal; the plane in which  $g$  and  $g'$  are found is, therefore, in its ultimate position, a horizontal plane. This plane is manifestly a tangent plane to the surface spoken of in the text.

# INDEX.

ART.	PAGE	ART.	PAGE
326	264	132	105
327	264	118	95
329	267	83, 111	66, 90
339	269	165	126
337	310	51	48
185	136	54	50
186	137	55	51
190	139	135	108
193	141	123	98
192	140	125	99
196	143	153	119
178	132	20	32
306	235	271	204
310	243	107	87
311	245	210	154
313	256	211	155
320	259	330	267
110	89	140	110
212	156	182	134
113	92	141	110
115	94	142	111
103	80	143	112
104	82	147	130
106	87	128	102
102	79	220	163
302	229	265	199
105	85	102	79
	300	1	27
280	209	242	181
315	253	330	303
318	257	322	259
322	259	2	27
323	260	81	65
149	116		
178	132		
185	236		

ART.	PAGE	ART.	PAGE
194	Dome, the.....	142	14 Force, represented in magni- tude and direction by lines
204	Ductility .....	150	17 — parallelogram of .....
208	— extent to which, may be developed .....	152	47 — of parallel.....
130	Eccentric, the .....	104	33 — polygon of .....
198	Elasticity .....	147	20 — resolution and compo- sition of.....
200	— its law ascertained by torsion .....	147	49 — preserving their paral- lelism in all positions of the body to which they are applied, their resultant passes always through the same point .....
209	— its measure; its modulus	153	174 Framing of timbers .....
326	— of the air .....	264	70 Friction .....
327	— proved by experiment .	264	125 — of cog wheels .....
329	— proportional to den- sity.....	267	142 — of a cord .....
265	Embankments .....	199	109 Fulcrum of levers .....
138	Endless screw .....	108	26 — reaction of .....
5	Equality of pressures .....	27	122 Fusee, the .....
4	Equilibrium of pressures ...	27	331 Gauge, the.....
21, 22	— of three pressures acting on a solid mass ...	33	51 Gravity, centre of .....
32	— of any number of pres- sures applied to a point ..	40	54 — method of finding.....
35	— — any where in the same plane .....	42	55 — illustrations of .....
47	— of parallel forces .....	48	283 — of a floating body, and that of the part immersed, in the same vertical .....
213	— heavy bodies resting on plane or curved bases, sta- bility of the .....	157	296 — specific, its unit .....
159	— of a system of variable form .....	123	300 — rule for finding .....
249	— of a heavy fluid.....	187	301 — applied to solid bodies
282	— of floating bodies .....	213	303 — applied to fluids .....
291	— — stability of the.....	219	Gravities, table of specific... 239
295	— — analogy between the conditions of, and those of a body resting on a smooth plane.....	223	194 Groin, the .....
307	Fahrenheit's hydrometer ...	235	272 Horizontal pressures of a fluid upon a heavy body immersed in it, counteract one another .....
346	Fire engine .....	281	205
141	Flexibility .....	110	273 — — their amount .....
242	Fluid, definition of a.....	181	138 Hunter's screw .....
244	Fluid pressure; its equal dis- tribution .....	182	303 Hydrostatic balance, the ... 229
303	Fluids, methods of finding the specific gravities of....	228	246 — press, the.....
1	Force; definition of .....	27	304 Hydrometer, the .....
2	— its direction .....	27	307 — Fahrenheit's.....
3	— its effect the same wherever applied in the line of its direction .....	27	308 — Nicholson's .....
4	— its equilibrium .....	22	305 — Sikes' .....
5	— its equality .....	27	55, 57 Illustrations of the centre of gravity .....
8, 9	— the unit of .....	28	51
10	— the measure of.....	28	23 — of the parallelogram of forces .....
			34 — of the polygon of forces
			41
			79 Inclined plane, the .....
			64
			86 — moveable, the .....
			67

ART.	PAGE	ART.	PAGE
112	Irregularity in the action of a force applied to the extremity of a lever, when its direction passes always through the same point— and method of remedying	144	Pulley, single fixed
	91	147	— single moveable
202	Lead, elasticity of	157	— Smeaton's
239	Least resistance, the principle of	158	— White's
95	Lever, the	151	Pulleys, first system of
96, 109	— re-action of its fulcrum	152	— second system of
	74, 89	336	Pump, the air
97	— applications of	337	— experiments with
110	— axis of a	343	— the forcing
106	— bent, balance	342	— the lifting
107	— compound	341	— the suction
99	— effects of the weight of	290	Pyramid, equilibrium of a floating
131	— Stanhope-press		219
342	Lifting pump	96	Re-action of a fulcrum
186	Line of pressure	84	Representation of forces by lines
	137		28
10	Measure of force	70	Resistance of a surface
209	— of elasticity	70	— limiting angle of
135	Micrometer screw	235	— theory of statical
209	Modulus of elasticity	20	Resolution of forces
281	Motion of rockets	271	— of the pressure of a heavy fluid
86	Moveable inclined plane		204
148	— pulley	281	Rocket, the motion of
	116	163	Rods, the suspended polygon of
308	Nicholson's Hydrometer		125
	236	170	— the upright polygon of
47	Parallel forces, equilibrium of	100	Roman statera, the
	48	190	Rupture of an arch, the points of
17	Parallelogram of forces		139
23	— illustrations of	133	Screw, the, its theory
79	Plane, inclined, the	140	— the conical
86	— moveable, the	138	— the endless
310	Pneumatics, definition of	138	— Hunter's
190	Points of rupture of an arch	135	— the micrometer
33	Polygon of forces, the	193	Settlement of the arch
34	— illustration of	305	Sikes' hydrometer
163	— of rods, the suspended	324	Siphon, the
170	— — the upright	157	Smeaton's pulley
246	Press, the hydrostatic	182	Solid bodies in contact, conditions of equilibrium of
267	Pressure, centre of	296	Specific gravity
186	— line of	301	— of solid bodies, method of finding
268	Pressure, whole amount of the, of a fluid upon a surface		228
	200	303	— of fluids
340	— atmospheric	308	— table of
239	Principle of least resistance	291	Stability of floating bodies
227	— virtual velocities	219	— of solid bodies whose bases are plane surfaces
289	Prism, equilibrium of a floating		162
	217	220	— — — curved surfaces
143	Pulley, the		163
	113	131	Stanhope-press lever, the
		100	Statera, the, or Roman steel-yard
			78



ART.	PAGE	ART.	PAGE
234	Statical resistance; difficulty of determining <i>experimentally</i> amount of .....	87	Wedge, the .....
	174	88	— angle of, must not exceed the limiting angle of resistance.....
101	Steelyard, the common.....		69
205	Structure, permanent alteration of internal .....	89	— circumstances under which, cannot be started....
	150	90	— examples of the use of
341	Suction pump, the .....	108	Weighing machine.....
	277		88
212	Surface, the neutral .....	282	Weight of a <i>floating</i> body equal to that of the fluid it displaces .....
222	Surfaces of unrest.....		213
	164	113	Wheel and axle.....
333	Syringe, the .....		90
	270	111	Wheel, the carriage .....
159	System, equilibrium of a rigid and of a variable.....		90
	123	123	Wheels, cog .....
123	— of cog-wheels .....		98
	94	119	— tread .....
315	Torricelli's discovery of the barometer .....		96
	253	120	— — worked by horses....
8, 9	Unit of force, the .....	323	Wheel barometer, the .....
	28		260
222	Unrest, surfaces of .....	158	White's pulley .....
	164		122
291	Unstable equilibrium .....	135	Winch, the .....
	219		108
318	Variations of the barometer .....	117	Windlass, the.....
	257		95
227	Virtual velocities .....	178	Wooden bridges .....
	167		132
		180	— arches .....
			133

THE END.

Books on the Second Supplemental Catalogue  
of the  
Society for Promoting Christian Knowledge.

Lectures on Astronomy, delivered at King's College, London. By the Rev. H. Moseley, M.A., F.R.S.; one of Her Majesty's Inspectors of Schools. With numerous Wood-cuts. 5s. 6d.

Recreations in Astronomy. By Rev. Lewis Tomlinson, M.A. Many Wood-cuts. 4s. 6d.

Recreations in Physical Geography, or, The Earth as it is. By Miss R. M. Zornlin. With numerous Wood-cuts. 6s.

Readings in Science; being familiar Explanations of Appearances and Principles in Natural Philosophy. With many Wood-cuts. 5s.

Popular Physiology; familiar Explanations of Interesting Facts connected with the Structure and Functions of Animals, and particularly of Man. By P. B. Lord, M.B. Many Engravings. 7s. 6d.

Easy Lessons in Mechanics; with Familiar Illustrations of the Practical Application of Mechanical Principles. 3s.

Natural Philosophy for Beginners. With upwards of One Hundred Wood-cuts. 3s. 6d.

The Useful Arts employed in the Production of Food. With numerous Wood-cuts. 2s. 6d.

The Useful Arts employed in the Production of Clothing. With numerous Wood-cuts. 2s. 6d.

The Useful Arts employed in the Construction of Dwelling-Houses. With numerous Wood-cuts. 2s. 6d.

The House I Live in; or, Popular Illustrations of the Structure and Functions of the Human Body. With Wood-cuts. 2s. 6d.

Minerals and Metals; their Natural History and Uses in the Arts; with Incidental Accounts of Mines and Mining. With Many Cuts. 2s. 6d.

Domesticated Animals considered with reference to Civilization and the Arts. With Wood-cuts. By Mary Roberts. 3s. 6d.

Wild Animals; their Nature, Habits, and Instincts: and the Regins they inhabit. With Wood-cuts. By the same. 3s. 6d.

**A Familiar History of Birds; their Nature, Habits, and Instincts.** By the Right Rev. Edward Stanley, D.D., Lord Bishop of Norwich. Two Volumes, with many Wood-cuts. 7s.

**The Animal and Vegetable Productions of America.** With Woods-cuts. By Mary Roberts. 3s. 6d.

**The Theory and Practice of Arithmetic,** comprising all the usual Rules with their Proofs; Scales of Notation; Logarithms; Mensuration; Formula for calculating the Horse-power of Steam-Engines, Water-Wheels, &c. By W. H. Crank, late Mathematical Master, St. Mark's College, Chelsea. Strongly bound. 4s.

**Elements of Algebra.** By the Rev. T. G. Hall, Professor of Mathematics in King's College, London. 6s. 6d.

**Easy Lessons on Reasoning.** By the Author of Easy Lessons on Money Matters. 1s. 6d.

Readings in English Prose Literature. 4s. 6d.

Readings in Poetry. 4s. 6d.

Readings in Biography. 4s. 6d.

**The Student's Manual of Ancient History.** By Dr. Taylor. 10s. 6d.

**The Student's Manual of Modern History.** By the same. 10s. 6d.

**History of the Christian Church, from the Ascension of Jesus Christ to the Conversion of Constantine.** By the late Dr. Burton. 6s. 6d.

**The Civil History of the Jews, from Joshua to Hadrian.** By the Rev. O. Cockayne, M.A., of King's College, London. With Maps. 4s. 6d.

**The Early Christians; their Manners and Customs, Trials and Sufferings.** By the Rev. W. Pridden, M.A. 4s.

**Bible Maps; an Historical and Descriptive Atlas of Scripture Geography,** wherein the Ancient Authorities are verified and corrected, from the information of Travellers and Writers up to the present time. By William Hughes, F.R.G.S. Bound in cloth, and the Maps coloured. 7s. 6d.

**LONDON: JOHN W. PARKER, WEST STRAND.**

