

TM 1-1680-361-10

**TECHNICAL MANUAL
OPERATOR'S MANUAL
FOR
AIRCREW INTEGRATED RECOVERY
SURVIVAL ARMOR VEST AND
EQUIPMENT (AIRSAVE)**

**NSN 8415-01-442-1991
NSN 8470-01-441-2993(S)
NSN 8470-01-441-2986(S)
NSN 8470-01-442-2062(S)**

DISTRIBUTION STATEMENT A: Approved for
public release: distribution is unlimited.

**HEADQUARTERS,
DEPARTMENT OF THE ARMY**

1 AUG 99

1

1

WARNING SUMMARY

FLIGHT OPERATIONS WITH AIRSAVE

Prior to flight operations in any aircraft, aircrew members must ensure that the AIRSAVE vest and ballistic insert do not interfere with flight controls, weapons systems operation, or restrict performance of in-flight duties. The AIRSAVE vest may be used in lieu of the current restraint harness, commonly referred to as the "monkey harness."

ARMOR INSERT

Ensure carrier's closure flap is securely fastened. The armor insert is heavy and could injure legs and feet if inadvertently dropped.

LIFT PREPARATION

When wearing the .30 caliber plate in an over-water mission/operations the vest shall be zipped closed only 2-3 inches from the bottom of the vest and snapped closed with the strap. When wearing the .50 caliber plate in an over-water mission/operation the slide fastener shall be closed to the top of the vest and the bottom slide fastener shall be open approximately 3 inches from the bottom. These procedures will allow easier removal of the plate. During all other operations the vest slide fastener shall be closed.

TRIOXANE COMPRESSED FUEL

Fuel contains metaformaldehyde, which is highly toxic. Don't put hands near mouth or eyes after handling opened or leaking packages. Wash hands immediately.

For first aid procedures, refer to FM 21-11.

WARNING SUMMARY - Continued

LPFC INFLATION TUBES

When using the manual inflation tubes, do not activate CO2 cartridge. Do not inhale air from inside of inflated bladder. Severe lung damage may occur.

HEED REGULATOR

When regulator ON/OFF valve is on and HEED is under pressure, ensure pressure indicator pin is directed away from face and exposed body parts. Should internal structural failure of pressure indicator pin occur, ejected fragments of pin could cause serious personal injury.

SURVIVAL ITEMS STOWAGE

- Additional items may be stowed in the general and inside pockets of the survival vest at the discretion of the aircrew member. Additional pockets may be added with the approval of the Unit Commander. However, the total weight of the additional items shall not exceed 5 pounds. Each item must be secured to the pocket with a minimum 30-inch length of nylon cord and must be stowed in a manner which will maintain equal weight balance of the vest. Additional items must also be stowed in such a manner so as not to adversely affect the ability of aircrew member to utilize flight controls and perform flight operational duties.
- Over-water items, i.e. life preservers, HEED/HABD, etc., must be properly attached and adjusted to preclude interference with aircraft flight controls.

WARNING SUMMARY - Continued

SOFT BALLISTIC INSERTS CLEANING

Do not soak soft ballistic inserts or use bleach or starch.

SOFT BALLISTIC INSERT CASINGS

- Do not leave ballistic aramid cloth exposed to direct sunlight. Continuous exposure to ultraviolet rays for an extensive period of time will seriously deteriorate the soft armor.
- Remove all soft ballistic insert assemblies prior to washing the casing assembly. Ensure that casing is dry before assembly.
- JP-5 fuel, grease or other combustibles embedded in casing assembly fabric will burn at their normal flash points even though the aramid cloth will not burn until a higher temperature is reached. Be sure the casing assembly is thoroughly clean and free of combustibles prior to further use. Machine wash as necessary.

LPFC

Ensure that the beaded inflation handles are readily accessible. Beaded inflation handles shall be secured with six snap fasteners.

[

]

L

]

LIST OF EFFECTIVE PAGES

INSERT LATEST UPDATED PAGES/WORK PACKAGES.
DESTROY SUPERSEDED DATA.

LIST OF EFFECTIVE PAGES/WORK PACKAGES

NOTE: The portion of text affected by the updates is indicated by a vertical line in the outer margins of the page. Updates to illustrations are indicated by miniature pointing hands. Updates to wiring diagrams are indicated by shaded areas.

Dates of issue for original and updated pages/work packages are:

Original 0 1 Aug 99

TOTAL NUMBER OF PAGES FOR FRONT AND REAR
MATTER IS 22 AND TOTAL NUMBER OF WORK PACKAGES
IS 13 CONSISTING OF THE FOLLOWING:

Page/WP No.	*Revision No.	
Title	0	
a-b	0	
A-B	0	
i-iv	0	
WP 0001 00 thru 0013 00	0	
Index	0	

*Zero in this column indicates an original page or work package.

[

]

L

]

TECHNICAL MANUAL

OPERATOR'S MANUAL
FOR
AIRCREW INTEGRATED RECOVERY
SURVIVAL
ARMOR VEST AND EQUIPMENT (AIRSAVE)

**REPORTING ERRORS AND RECOMMENDING
IMPROVEMENTS**

You can help improve this manual. If you find any mistakes, or if you know of a way to improve the procedures, please let us know. Mail your letter or DA Form 2028 (Recommended Changes to Publications and Blank Forms) direct to: Commander, U.S. Army Aviation and Missile Command (AMCOM), ATTN: AMSMI-MMC-LS-LP, Redstone Arsenal, AL 35898-5238. A reply will be furnished to you.

DISTRIBUTION STATEMENT A: Approved for public release; distribution is unlimited.

HEADQUARTERS, DEPARTMENT OF THE ARMY

[

]

L

]

TABLE OF CONTENTS

WP Sequence No.

WARNING SUMMARY

CHAPTER 1. INTRODUCTORY INFORMATION WITH THEORY OF OPERATION

General Information.....	0001 00
Equipment Description and Data	0002 00
Theory of Operation.....	0003 00

CHAPTER 2. OPERATOR INSTRUCTIONS

Description and Use of Operator Controls and Indicators.....	0004 00
Operation Under Usual Conditions.....	0005 00
Operating Auxiliary Equipment Under Usual Conditions	0006 00

CHAPTER 3. OPERATOR MAINTENANCE INSTRUCTIONS

PMCS, Including Lubrication Instructions.....	0007 00
Operator Maintenance.....	0008 00

TABLE OF CONTENTS - Continued

WP Sequence No.

CHAPTER 4. SUPPORTING INFORMATION

References	0009 00
Components of End Item (COEI) and Basic Issue Items (BII) Lists	0010 00
Additional Authorization List (AAL)	0011 00
Expendable and Durable Items List	0012 00
Emergency Evacuation Procedures: Using the Safety Restraint Tether.....	0013 00

ALPHABETICAL INDEX

TM 1-1680-361-10

CHAPTER 1

INTRODUCTORY INFORMATION WITH THEORY OF OPERATION

GENERAL INFORMATION WORK PACKAGE

0001 00

SCOPE

This manual, issued expressly for the Army aircrew member, is an official document for the A/P22P-18(V) Aircrew Integrated Recovery Survival Armor Vest and Equipment (AIRSAVE) used with Army, Navy and Marine Corps aircraft. The purpose of this manual is to provide information on the AIRSAVE configuration and its intended use and operation. This manual also provides instruction for the use of survival items that will be stowed in the modular pockets attached to the AIRSAVE survival vest.

MAINTENANCE FORMS, RECORDS, AND REPORTS

Department of the Army forms and procedures used for equipment maintenance will be those prescribed by DA PAM 738-750, *Functional Users Manual for the Army Maintenance Management System (TAMMS)* and DA PAM 738-751, *Functional Users Manual for the Army Maintenance Management System – Aviation (TAMMS-A)*.

0001 00-1

**GENERAL INFORMATION WORK PACKAGE –
Continued**

0001 00

**REPORTING EQUIPMENT IMPROVEMENT
RECOMMENDATIONS (EIR)**

If your AIRSAVE needs improvement, let us know. Send us an EIR. You, the user, are the only one who can tell us what you don't like about your equipment. Let us know why you don't like the design or performance. Put it on an SF 368 (*Product Quality Deficiency Report*). Mail it to the address specified in DA PAM 738-750, *Functional Users Manual for the Army Maintenance Management System (TAMMS)* or DA PAM 738-751, *Functional Users Manual for the Army Maintenance Management System – Aviation (TAMMS-A)*. We will send you a reply.

CORROSION PREVENTION AND CONTROL (CPC)

Corrosion Prevention and Control (CPC) of Army material is a continuing concern. It is important that any corrosion problems with this item be reported so that the problem can be corrected and improvements can be made to prevent the problem in future items.

While corrosion is typically associated with rusting of metals, it can also include deterioration of other materials, such as rubber and plastic. Unusual cracking, softening, swelling, or breaking of these materials may be a corrosion problem.

**GENERAL INFORMATION WORK PACKAGE –
Continued**

0001 00

**CORROSION PREVENTION AND CONTROL (CPC) -
Continued**

If a corrosion problem is identified, it can be reported using SF 368, *Product Quality Deficiency Report*. Use of key words such as "corrosion," "rust," "deterioration," or "cracking" will ensure that the information is identified as a CPC problem. The form should be submitted to the address specified in DA PAM 738-750, *Functional Users Manual for the Army Maintenance Management System (TAMMS)* or DA PAM 738-751, *Functional Users Manual for the Army Maintenance Management System – Aviation (TAMMS-A)*.

**DESTRUCTION OF ARMY MATERIEL TO PREVENT ENEMY
USE**

Perform in accordance with TM 750-244-1-2, *Procedures for Destruction of Life Support Equipment to Prevent Enemy Use*.

PREPARATION FOR STORAGE OR SHIPMENT

Refer to Work Package 0009 00.

**GENERAL INFORMATION WORK PACKAGE –
Continued**

0001 00

LIST OF ABBREVIATIONS AND ACRONYMS

AAL	Additional Authorization List
ABDU	Aircrew Battle Dress Uniform
AIRSAVE	Aircrew Integrated Recovery Survival Armor Vest and Equipment
ALSE	Aviation Life Support Equipment
ALSS	Aviation Life Support System
BII	Basic Issue Items
COEI	Components of End Item
CPC	Corrosion Prevention and Control
EIR	Equipment Improvement Recommendations
HABD	Helicopter Aircrew Breathing Device (SRU-40/P)
HEED	Helicopter Emergency Egress Device (SRU-36/P)
LPFC	Low Profile Flotation Collar
MCW	Modulated Continuous Wave
PMCS	Preventive Maintenance Checks and Services
POL	Petroleum, Oils, Lubricants
SAR	Search and Rescue
SOP	Standard Operating Procedure
SRT	Soldier Safety Restraint Tether
TAMMS	The Army Maintenance Management System
WP	Work Package

**EQUIPMENT DESCRIPTION AND DATA
WORK PACKAGE**

0002 00

**EQUIPMENT CHARACTERISTICS, CAPABILITIES, AND
FEATURES**

The A/P22P-18(V) provides the aircrew member with integrated survival item stowage, small arms threat protection, flotation device integration, and a Search and Rescue (SAR) lift hoist attachment capability. Components required to assemble AIRSAVE are the Type I Survival Vest Assembly, Soft Body Armor Assembly, Hard Body Armor Assembly, and individual external storage pockets.

Survival Vest Assembly

The survival vest assembly is an adjustable, one-size-fits-all garment, and contains an assortment of modular pockets to accommodate stowage of survival items. The Type I survival vest is used by aircrew members of both helicopter and fixed-wing, non-ejection seat aircraft. Unique features of the Type I vest include a hoisting harness attached to the inside of the vest to accommodate SAR lift hoist attachment, and a two-way plastic slide fastener to accommodate hard armor operation and doffing.

EQUIPMENT DESCRIPTION AND DATA
WORK PACKAGE - Continued

0002 00

EQUIPMENT CHARACTERISTICS, CAPABILITIES, AND FEATURES - Continued

Soft Body Armor Assembly

The soft body armor is available in two sizes, medium and large, and consists of a front and back casing, each with ballistic inserts. The front and back casings are fitted to the aircrew member with hook and pile fasteners on each shoulder and adjustable side straps. The ballistic inserts are constructed of a multi-layered, ballistic, high-strength aramid cloth, sealed in a water-repellant nylon cover, and are contained inside the front and back casing. The front plate is inserted into the pouch on the lower front of the casing. This provides stability for the front hard armor plate. The soft body armor is designed to stop shrapnel from 37 MM HEI rounds.

Hard Body Armor Assembly

The hard body armor is available in two sizes, medium and large, and consists of front and back armor plates, each of which are stowed inside a front and back hard armor encasement. The hard armor plates are constructed of a ceramic, ballistic, composite which provides torso protection against small arms fire up to .30 caliber. Hard body armor is designed to stop 762 X 63 AP rounds.

.50 Caliber Hard Body Armor

The Army has a hard armor plate that provides standoff protection against .50 caliber rounds. It may be used with the AIRSAVE vest but it is not meant to be worn with the soft armor. It comes in four sizes: S, M, L, and XL (refer to TM 1-1680-359-10 and TM 55-1680-317-23&P).

EQUIPMENT DESCRIPTION AND DATA
WORK PACKAGE - Continued

0002 00

EQUIPMENT CHARACTERISTICS, CAPABILITIES, AND
FEATURES - Continued

Life Preserver Assembly

The AIRSAVE ensemble is authorized to be worn with a flotation device. AIRSAVE is designed to be compatible with the following life preservers:

<u>Nomenclature</u>	<u>Service</u>
LPU-34/P	Army/Navy/Marine Corps
LPU-21/P	Army/Navy/Marine Corps
LPU-18/P	Army/Navy/Marine Corps
LPU-10	Army

LPU-34/P Low Profile Flotation Collar (LPFC)

NOTE

For Army users, LPU 34/P is compatible only with AIRSAVE vest. It has NOT been tested or authorized for use with SARVIP or other vests.

The LPU-34/P LPFC is designated for use by aircrew personnel operating aircraft which are not equipped with ejection seat systems. It is designed for constant wear when wearing compatible flight clothing and equipment.

EQUIPMENT DESCRIPTION AND DATA
WORK PACKAGE - Continued

0002 00

EQUIPMENT CHARACTERISTICS, CAPABILITIES, AND FEATURES - Continued

SRU-36/P Helicopter Emergency Egress Device (HEED)

The SRU-36/P HEED is a compact, lightweight breathing assembly intended for emergency use of helicopter and E-2/C-2 aircrew personnel in the event of crash landing in water (ditching). The SRU-36/P provides emergency breathing air, upon demand, to aid in safe egress from submerged aircraft. The device provides seven to ten breaths of breathing air at a water depth of 20 feet and temperature of 55° F.

Safety Restraint Tether (SRT)

The Safety Restraint Tether (SRT) provides the aircrew member with a “positive” attachment point to the outside of a rescue aircraft. The SRT is to be used (during emergency situations) when a downed aircrew member has to be evacuated by a rotary-wing aircraft with limited interior space and no other aircraft is available to perform the pickup. See SRT operating procedures in WP 0013 00.

EQUIPMENT DESCRIPTION AND DATA
WORK PACKAGE - Continued

0002 00

LOCATION AND DESCRIPTION OF MAJOR COMPONENTS
AIRSAVE Vest and Modular Pocket Attachment

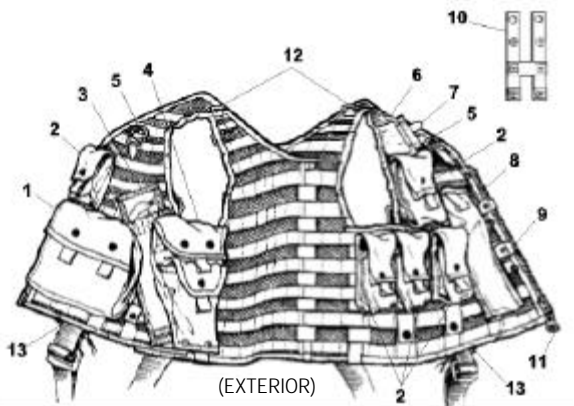

- | | |
|---|--|
| 1. Radio Pocket | 8. Knife Pocket |
| 2. General Pocket (5) | 9. Flashlight Keeper |
| 3. HEED (SRU-36P) Pocket | 10. Oxygen/CBR Attachment (Navy) |
| 4. Pistol Holster Pocket with
Ammo Keeper (Optional) | 11. Slide Fastener |
| 5. Collar Lobe Attachment (2) | 12. Loop Locs (2) (for rear plate
attachment) |
| 6. Gated D-Ring | 13. Harness Retainer (2) |
| 7. Gated D-Ring Cover | |

EQUIPMENT DESCRIPTION AND DATA
 WORK PACKAGE - Continued

0002 00

LOCATION AND DESCRIPTION OF MAJOR COMPONENTS
 - Continued

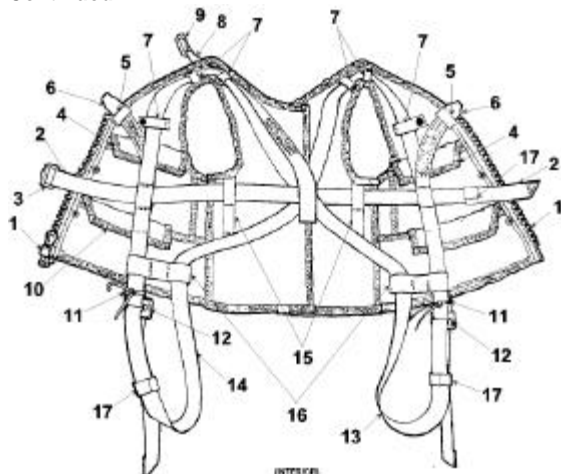

- | | |
|----------------------------------|------------------------------|
| 1. SLIDE FASTENER | 10. INSIDE POCKETS |
| 2. CHEST HARNESS | 11. HARNESS RETAINER CORD |
| 3. FRICTION ADAPTER (CHEST) | 12. FRICTION ADAPTERS (LEGS) |
| 4. INSIDE POCKETS | 13. LEFT LEG STRAP |
| 5. FRONT LIFT ATTACHMENT CHANNEL | 14. RIGHT LEG STRAP |
| 6. FRONT LIFT ATTACHMENT LOOP | 15. CHEST STRAP CHANNELS |
| 7. HARNESS RETAINER STRAPS | 16. LEG STRAP RETAINERS |
| 8. LIFT STRAP | 17. HARNESS KEEPERS |
| 9. GATED D-RING | |

EQUIPMENT DESCRIPTION AND DATA
WORK PACKAGE - Continued

0002 00

LOCATION AND DESCRIPTION OF MAJOR COMPONENTS
- Continued

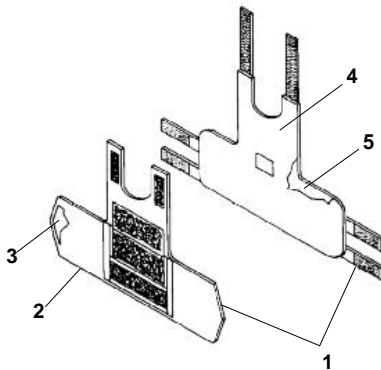

1. Small Arms Protective Soft Body Armor
2. Front Casing Assy
3. Front Soft Ballistic Insert Assy
4. Back Casing Assy
5. Back Soft Ballistic Insert Assy

EQUIPMENT DESCRIPTION AND DATA
WORK PACKAGE - Continued

0002 00

LOCATION AND DESCRIPTION OF MAJOR COMPONENTS
- Continued

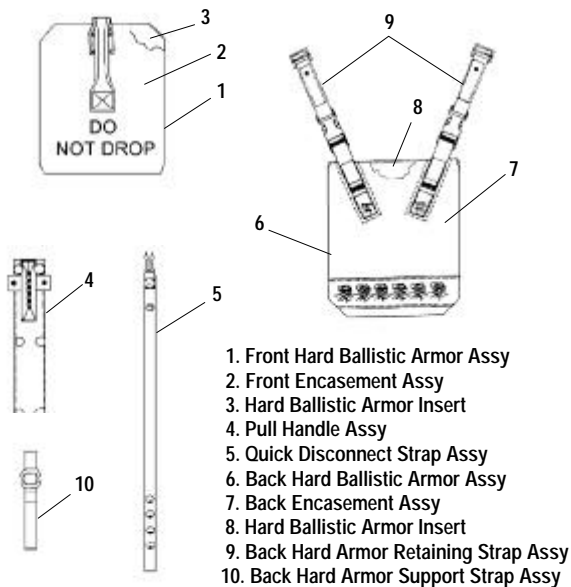

EQUIPMENT DESCRIPTION AND DATA
WORK PACKAGE - Continued

0002 00

LOCATION AND DESCRIPTION OF MAJOR COMPONENTS
- Continued

LPU-34/P LPFC

The LPU-34/P LPFC consists of an exterior cover assembly, inflation shell assembly, and a flotation assembly. The flotation assembly consists of two independent inflatable bladders, each of which is equipped with a manual inflation device and an oral inflation valve. Four straps on the inflation shell assembly attach the LPU-34/P to the survival vest. A beaded handle on each side of the exterior cover initiate inflation of the life preserver. Two additional straps adjust a plastic buckle which snaps across the wearer's chest to keep the LPU-34/P in position when worn.



FRONT VIEW



BACK VIEW

EQUIPMENT DESCRIPTION AND DATA
WORK PACKAGE - Continued

0002 00

LOCATION AND DESCRIPTION OF MAJOR COMPONENTS
- Continued

SRU-36/P HEED

NOTE

SRU 36/P requires initial training and annual refresher training before use by aviators and aircrew members.

The SRU-36/P HEED is composed of two major components: a high pressure aluminum air cylinder and a demand type regulator with attached mouthpiece.

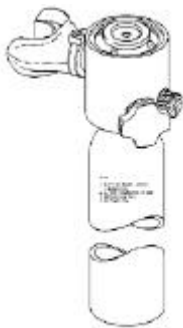

SRT

The SRT consists of a nylon strap sewn into a 4-foot loop, with a maximum load limit of 3000 pounds.

EQUIPMENT DESCRIPTION AND DATA
WORK PACKAGE - Continued

0002 00

EQUIPMENT DATA

Vest, Survival, Aircrewman's
(AIRSAVE), Type I, Basic
Configuration w/Harness

Weight: 5.2 pounds

Body Armor, Soft, Small Arms
Protective PRU-60A/P22P

Size Medium w/Carrier

Weight: 9.25 pounds

Size Large w/Carrier

Weight: 10.75 pounds

Body Armor, Hard, Small Arms
Protective PRU-61A/P22P

Size Medium w/Carrier

Weight: 6.4 pounds

Size Large w/Carrier

Weight: 7.3 pounds

LPU-34/P LPFC

Weight: 3 pounds 14 ounces

Buoyancy: 65 pounds

SRU-36/P HEED Air Cylinder

Capacity: 1.8 cubic feet of air

Pressure: 1800 psi

SRT

Loop Length: 4 feet

Stitching: Six bar tacks

Maximum Load Limit:

3000 pounds

[

]

[

]

SURVIVAL VEST ASSEMBLY

The A/P22P-18(V) AIRSAVE survival vest is designed to replace all current Army survival vests. The AIRSAVE was designed to be usable in all rotary wing and non-ejection seat fixed wing aircraft communities. The type I vest includes a removable hoisting harness and detachable stowage pockets which permit various configurations of survival items and equipment.

The type I vest is designed for use by all aircrews in conjunction with the aircrew armor assemblies. The vest may be worn with the soft and hard body armor systems. The .30 caliber plates must be worn with soft armor. The .50 caliber hard armor must be worn without soft armor. The survival vest may be worn without any armor. The two-way plastic slide fastener on the front allows the vest to be opened from either the top or bottom for easier access for armor disconnect.

The Army Helo CBR Nuclear Biological Chemical (NBC) unit is attached to the crewmember's upper left shoulder on the vest. The Army Apache configuration has the NBC unit attachment strapped to either the left or right arm.

For over-water missions, the LPU-34/P Low Profile Flotation Collar (LPFC) is attached to the survival vest. The SRU-36/P Helicopter Emergency Egress Device (HEED) is carried in the HABD pocket of the vest to provide on-demand breathing air supply in case of egress under water.

**THEORY OF OPERATION WORK PACKAGE –
Continued**

0003 00

LPU-34/P LPFC

WARNING

When using the manual inflation tubes, do not inhale CO₂ that may be present (under pressure) in the flotation cells. Severe lung damage may occur.

The inflation shell assembly contains two inflatable bladders. The LPU-34/P LPFC is inflated by pulling the beaded handles on each side of the exterior cover. Each beaded handle is connected by a lanyard to the actuating lever of an inflation device. Pulling the handles initiates zipper separation on the exterior cover and causes the CO₂ cylinder to be punctured, inflating the bladders. The zipper on the exterior cover continues to separate as the bladders inflate to provide head-out-of-water buoyancy.

In an emergency situation, the oral inflation tubes may be used to top off the inflated bladders, maintain inflation in a leaky bladder, or inflate a bladder if an inflation device malfunctions. The oral inflation tube may also be used to inflate the bladders during an inspection test or to evacuate air to perform packing.

**THEORY OF OPERATION WORK PACKAGE –
Continued**

0003 00

SRU-36/P HEED

Inhaling creates a negative pressure within the demand chamber which pulls the diaphragm down. The diaphragm depresses the poppet lever, forcing the poppet valve into the open position. This permits cylinder air to flow through the regulator assembly to the mouthpiece. When inhalation ceases, the diaphragm returns to its static position. The poppet lever also returns to its static position, the poppet valve closes, and air flow from the cylinder ceases. Exhaled air flows through the mouthpiece into the demand chamber and out the main body exhaust ports in the bottom of the regulator. When exhaled air pressure ceases, the flexible exhaust disc seats to prevent water entry. The SRU-36/P will continue to function until air pressure in the cylinder is depleted.

SRT

The tether is intended to provide the aircrew member with a safety “backup” attachment while being extracted externally on the following aircraft with limited internal space: AH-64A, AH-1F, and OH-58D(I).

1

1

CHAPTER 2

OPERATOR INSTRUCTIONS

DESCRIPTION AND USE OF OPERATOR CONTROLS AND INDICATORS WORK PACKAGE **0004 00**

SURVIVAL VEST

Two-Way Front Slide Fastener

The front slide fastener can be opened from either the top or the bottom.

- a. Survival vest worn without body armor: The vest shall be worn with harness and specified survival gear, and the vest shall be zipped closed.
- b. Survival vest worn with soft body armor: The vest shall be worn with harness and specified survival gear, and the vest shall be zipped closed.
- c. Survival vest worn with .30 caliber plates and soft body armor: The vest shall be worn with harness and specified survival gear. The plate shall be inserted into the pocket flap at the base of the soft body armor, then fastened into place with hook-and-pile tape. Then the vest shall be zipped closed approximately 3 inches from the bottom of the vest. Survival vest shall then be completely closed with the armor quick-disconnect handle snapped into place.

DESCRIPTION AND USE OF OPERATOR CONTROLS AND INDICATORS WORK PACKAGE - Continued **0004 00**

SURVIVAL VEST - Continued

Two-Way Front Slide Fastener - Continued

d. Survival vest worn with .50 caliber plate: The vest shall be worn with harness and specified survival gear, without soft body armor. The vest shall be zipped closed to the top and zipped open approximately 3 inches from the bottom. This will allow for easier emergency doffing of the armor plate through the base of the vest.

Hoisting Harness

Prepare for rescue/emergency lift by ensuring that:

- a. Vest slide fastener is fully engaged.
- b. Snap-link carabiner is properly installed through both front rescue lift loops or on right shoulder lift loop. For over-water operations, carabiner is installed to right shoulder lift loop.
- c. Adjustment straps at chest, waist, and legs provide snug fit.
- d. Upon arrival of rescue aircraft, attach rescue/lift cable fastener through your vest's snap-release carabiner for lift.

For over-land missions, the hoisting harness can be used as a gunner's belt. Pull the snap link out of its placement flap on the right shoulder, so strap comes out of the center of the back, and attach to the aircraft.

DESCRIPTION AND USE OF OPERATOR CONTROLS AND INDICATORS WORK PACKAGE - Continued 0004 00

SURVIVAL VEST - Continued

Detachable Stowage Pockets

Pockets for the stowage of survival items attach to the horizontal webbing sewn to the vest. Each pocket has a strap on the back which is interwoven through the horizontal webbing loops of the vest, then secured to the pocket by omni-directional snap fasteners. Since it is generally difficult to reach the inside stowage pockets of the vest after suiting up for flight, they should be used for items that are not needed for emergency egress or signaling.

LPU-34/P LPFC

Inflation Handles

A beaded handle which connects by lanyard to an inflation device is mounted on each side of the exterior cover. To inflate the LPFC, pull the beaded handles in a natural downward motion.

TM 1-1680-361-10

DESCRIPTION AND USE OF OPERATOR CONTROLS AND INDICATORS WORK PACKAGE - Continued **0004 00**

LPU-34/P LPFC - Continued

Inflation Handles – Continued

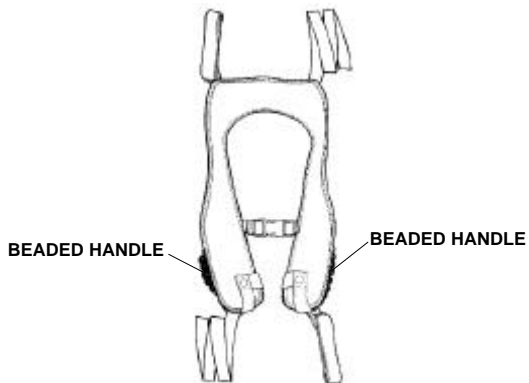

0004 00-4

DESCRIPTION AND USE OF OPERATOR CONTROLS AND INDICATORS WORK PACKAGE - Continued 0004 00

LPU-34/P LPFC - Continued

Manual Inflation Tubes

WARNING

When using the manual inflation tubes, do not inhale CO₂ that may be present (under pressure) in the flotation cells. Severe lung damage may occur.

The oral inflation tube of each bladder extends through the inflation shell assembly and is retained by inserting the top of each tube in retainer loops attached to the inflation shell assembly.

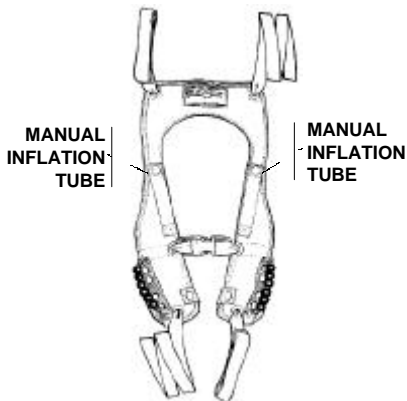

DESCRIPTION AND USE OF OPERATOR CONTROLS AND INDICATORS WORK PACKAGE - Continued **0004 00**

SRU-36/P HEED

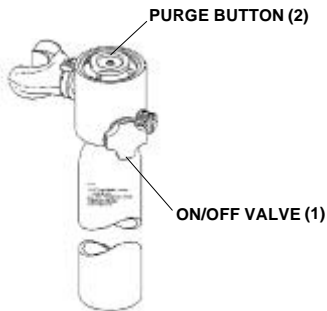

ON/OFF Valve

WARNING

When regulator ON/OFF valve is on and HEED is under pressure, ensure pressure indicator pin is directed away from face and exposed body parts. Should internal structural failure of pressure indicator pin occur, ejected fragments of pin could cause serious personal injury.

The HEED is activated by turning the ON/OFF valve (1) fully counterclockwise to the ON position. For flight operations, the ON/OFF valve shall be turned on when preflight inspection is performed and shall remain on until postflight inspection is performed.

**DESCRIPTION AND USE OF OPERATOR CONTROLS AND
INDICATORS WORK PACKAGE - Continued** **0004 00**

SRU-36/P HEED - Continued

Mouthpiece

Inhaling through the mouthpiece starts the flow of air.

Purge Button

Water will collect in the mouthpiece and demand chamber if the mouthpiece is not in place in aircrew member's mouth prior to submerging. Small amounts of water may collect in the same area during underwater use. Purge water from the mouthpiece and regulator by depressing the purge button (2). While underwater, with the mouthpiece in the mouth, exhale into mouthpiece before inhaling.

SRT

Currently the only aircraft that have been identified for use with the SRT are the AH-1F, AH-64A, and OH-58D(I). Attaching points for each aircraft are described in WP 0013 00.

[

]

L

]

**OPERATION UNDER USUAL CONDITIONS WORK
PACKAGE**

0005 00

ASSEMBLY AND PREPARATION FOR USE

WARNING

FLIGHT OPERATIONS WITH AIRSAVE

Prior to flight operations in any aircraft, aircrew members must ensure that the AIRSAVE vest and ballistic insert do not interfere with flight controls, weapons systems operation, or restrict performance of in-flight duties. The AIRSAVE vest may be used in lieu of the current restraint harness, commonly referred to as the "monkey harness."

Aviation Life Support System (ALSS) personnel will fit, pack and adjust the AIRSAVE vest and body armor in accordance with TM 1-1680-360-12. Unit Commanders should develop specific instructions in the Unit SOP for packing and wear of the AIRSAVE vest and body armor, that meet the specified missions of the organization. All AIRSAVE vest SOP packing lists should be reviewed and approved by Unit Commander, Flight Surgeon, and Safety Officer.

**OPERATION UNDER USUAL CONDITIONS WORK
PACKAGE - Continued**

0005 00

ASSEMBLY AND PREPARATION FOR USE - Continued

**Packing, Donning, and Doffing of AIRSAVE Vest and Body
Armor**

As a minimum, the pockets will be packed with the items from Table 1, Mandatory Survival Items List (Generic), in this work package. Recommended locations for modular pockets are illustrated in WP 0006 00, but when approved may vary depending on mission requirements. Since it is generally difficult to reach the inside pockets while the vest is donned, the inside pockets should be used to stow items that are not needed for emergency egress or signaling.

AIRSAVE Donning Procedures (Type I)

NOTE

The CMU-33A/P22P-18(V) survival vest may either be worn as a stand-alone item, or with the PRU-60A/P22P-15 soft armor, or with the soft armor and the PRU-61A/P22P-15 hard armor or with .50 caliber armor.

NOTE

The donning procedure for the Type I AIRSAVE system begins with the aircrew member in a flight suit/ABDU and boots.

**OPERATION UNDER USUAL CONDITIONS WORK
PACKAGE - Continued**

0005 00

ASSEMBLY AND PREPARATION FOR USE - Continued

AIRSAVE Donning Procedures (Type I) - Continued

1. Don the soft armor over head with the front panel attached to the rear panel at the shoulder area with the hook and pile straps. The pile tape on the front panel should face away from the body.
2. Secure the front and rear panels on the side by attaching the hook straps from the rear panel to the pile on the front panel.



0005 00-3

**OPERATION UNDER USUAL CONDITIONS WORK
PACKAGE - Continued**

0005 00

ASSEMBLY AND PREPARATION FOR USE - Continued

AIRSAVE Donning Procedures (Type I) - Continued

3. Place the front hard plate into the flap at the bottom of the front soft armor panel, making sure the handle is facing outward and located near the top of the plate. Press the hard armor against the soft armor panel to engage the hook and pile tape between the two.
4. Don the vest over the soft armor and front hard plate. Adjust the chest strap to the left side to prevent the buckle from interfering with the hard plate, and to obtain a more comfortable fit.
5. Close the slide fastener to the first snap on the vest. If the hard armor is not worn, close the slide fastener to the top.
6. For attachment of LPU-21/P, LPU-23/P, and LPU-34/P see NAVAIR 13-1-6.7.4/TM 1-1680-360-12.
7. LPU-10/P is a totally separate item. Don the LPU-10/P over the soft body armor. Adjust the chest strap to the left or right side to prevent the buckle from being under the hard plate. Next fit the hard plate to the hook and pile tape on the soft body armor chest area. Don the AIRSAVE vest ensuring that LPU-10/P lobes are pulled through each arm opening, such that they rest under each arm.

**OPERATION UNDER USUAL CONDITIONS WORK
PACKAGE - Continued**

0005 00

ASSEMBLY AND PREPARATION FOR USE - Continued
AIRSAVE Donning Procedures (Type I) - Continued

CAUTION

It is important that the AIRSAVE leg and rear tether straps are properly tightened and that the loose ends are stowed to eliminate the hazard of snagging the straps during emergency egress.

8. Thread the leg straps through the friction adapters and adjust for a snug fit.
9. Attach the beaded handle to the front of the vest with six snap fasteners.
10. If wearing the back armor plate, secure one of four snap fasteners on the quick disconnect straps to the beaded pull
11. Attach the back armor retaining straps to the front disconnect straps on the vest by placing the buckle of the rear straps over the loop lock of the vest. Then push the quick disconnect strap clip through the loop lock of the vest and fold strap over clip to secure snap.

**OPERATION UNDER USUAL CONDITIONS WORK
PACKAGE - Continued**

0005 00

ASSEMBLY AND PREPARATION FOR USE - Continued

AIRSAVE Donning Procedures (Type I) - Continued

NOTE

Donning the back armor plate requires assistance.

12. Attach the back armor retaining straps to the rear armor plate with side release buckles. The straps are adjustable by means of hook and pile tape.
13. Loop two straps to lower part of the vest and attach pile to hook of plate carrier.

Doffing of Hard Armor

1. In emergency situations, doff the hard body armor by gripping the beaded pull handle with either hand and giving a sharp outward and downward pull. This action simultaneously releases both the quick release strap clip and the loop slide from the loop lock, allowing the rear armor to separate and drop off of the wearer.
2. Discard the beaded handle and reach into the front of the vest. Grasp the handle attached to the front hard armor, pull away from chest, and discard it.

**OPERATION UNDER USUAL CONDITIONS WORK
PACKAGE - Continued**

0005 00

ASSEMBLY AND PREPARATION FOR USE - Continued

Doffing of Hard Armor - Continued

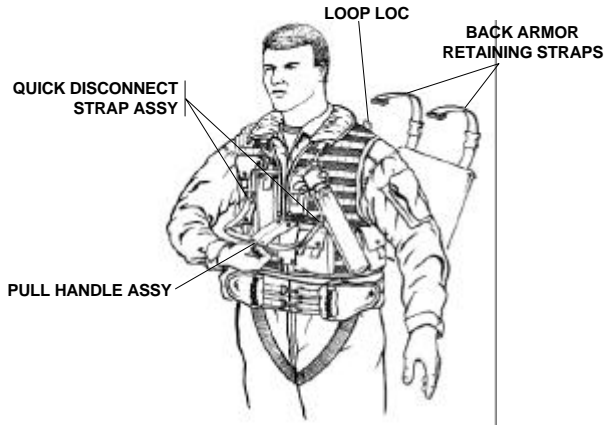

[

]

L

]

**OPERATING AUXILIARY EQUIPMENT UNDER USUAL
CONDITIONS WORK PACKAGE** **0006 00**

INSPECTIONS

Refer to WP 0007 00, Preventive Maintenance Checks and Services, for required pre-flight and post-flight inspections of AIRSAVE components.

AIRSAVE MODULAR POCKETS

The AIRSAVE vest will be fielded to Army Aviators with five General Pockets, one Radio Pocket and one Knife Pocket (Pistol and HEED/HABD Pockets are optional items that must be requisitioned by the unit). Suggested placement of items in specific pockets (in the Legend) are for illustrative purposes only. The packing and locations of pockets are to be developed and documented in the unit Standard Operating Procedures (SOP), taking into consideration the individual's body configuration and position in the aircraft (pilot, gunner, crewchief, etc.), the aircraft type, and any other valid mission consideration. ALL pocket packing and positioning considerations MUST be adjusted so they do not cause interference with aircraft flight controls and flight operations.

**OPERATING AUXILIARY EQUIPMENT UNDER USUAL
CONDITIONS WORK PACKAGE - Continued** 0006 00

AIRSAVE MODULAR POCKETS – Continued

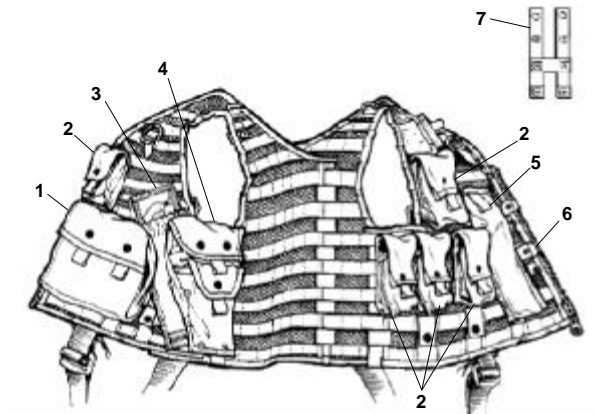

(EXTERIOR)

1. RADIO POCKET
2. GENERAL POCKET (5)
3. HEED/HABD POCKET (OPTIONAL)
4. PISTOL HOLSTER POCKET WITH AMMO KEEPER (OPTIONAL)
5. KNIFE POCKET
6. FLASHLIGHT KEEPER
7. OXYGEN/CBR ATTACHMENT

**OPERATING AUXILIARY EQUIPMENT UNDER USUAL
CONDITIONS WORK PACKAGE - Continued** 0006 00

AIRSAVE MODULAR POCKETS – Continued

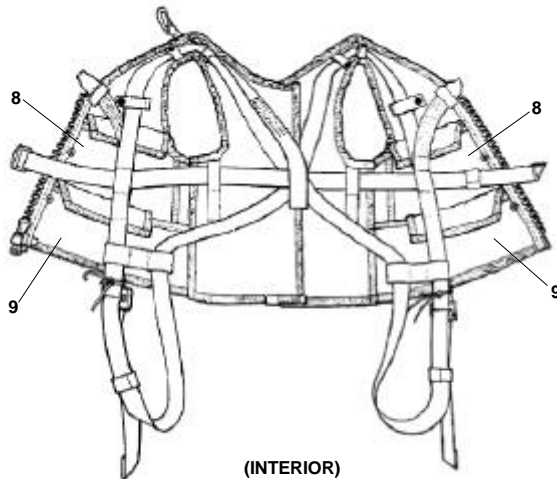

- 8. INSIDE POCKETS (WATER BAGS)
- 9. INSIDE POCKETS (GENERAL KIT, MEDICAL KIT)

**OPERATING AUXILIARY EQUIPMENT UNDER USUAL
CONDITIONS WORK PACKAGE - Continued** **0006 00**

AIRSAVE MODULAR POCKETS – Continued

WARNING

Additional items may be stowed in the general and inside pockets of the survival vest at the discretion of the aircrew member. Additional pockets may be added with the approval of the Unit Commander. However, the total weight of the additional items shall not exceed 5 pounds. Each item must be secured to the pocket with a minimum 30-inch length of nylon cord and must be stowed in a manner which will maintain equal weight balance of the vest. Additional items must also be stowed in such a manner so as not to adversely affect the ability of aircrew member to utilize flight controls.

The items listed in Table 1 are considered to be mandatory ALSE for packing in the AIRSAVE vest pockets or attachment to the vest. The items may vary from unit to unit based on availability and date acquired.

Mandatory and optional items may be selected from the Army Survival Item List in Appendix A of TM 1-1680-360-12, NAVAIR 13-1-6.7-4. Items not on the list but deemed mission essential must be approved by the 1st O5 level officer in the chain of command.

**OPERATING AUXILIARY EQUIPMENT UNDER USUAL
CONDITIONS WORK PACKAGE - Continued** **0006 00**

AIRSAVE MODULAR POCKETS – Continued

WARNING

Over-water items, i.e. life preservers, HEED/HABD, etc., must be properly attached and adjusted to preclude interference with aircraft flight controls.

Table 1. Mandatory Survival Item List (Generic)

- 1 Radio Set w/Battery
- 2 Light, Marker Distress, w/ Battery & Flashguard
- 3 Mirror, Emergency Signaling
- 4 Whistle, Ball Plastic OD (w/lanyard)
- 5 Kit, Signaling
- 6 Fire Starter (Note 1)
- 7 Pocket Knife
- 8 Compass
- 9 Bag, Storage, Drinking Water 3 Pint
- 10 Tourniquet, Non-Pneumatic
- 11 Insect Repellent & Sunscreen Prep.
- 12 Blanket, Thermal

**OPERATING AUXILIARY EQUIPMENT UNDER USUAL
CONDITIONS WORK PACKAGE - Continued** **0006 00**

AIRSAVE MODULAR POCKETS – Continued

**Table 1. Mandatory Survival Item List (Generic) -
Continued**

- 13 Aircrew Survival/First Aid Kit
- 14 Operator's Manual
- 15 Mission Essential Equipment (Note 2)
- 16 Optional Items (Note 2)

Note 1: Two fire starters required. DO NOT DUPLICATE.

Note 2: Optional items & other approved mission essential items not listed may be attached to the vest or carried in the general pockets or approved special pockets, must be properly attached/adjusted to preclude interference w/aircraft flight controls and flight operations.

CHAPTER 3

OPERATOR MAINTENANCE INSTRUCTIONS

PMCS, INCLUDING LUBRICATION INSTRUCTIONS WORK PACKAGE **0007 00**

THIS WORK PACKAGE COVERS:

Introduction, PMCS (Operator Pre-flight and Post-flight Inspection) Procedures

INITIAL SETUP:

Maintenance Level:

Operator

INTRODUCTION

General

This work package contains the procedures and instructions necessary to perform operator PMCS. The columns in the PMCS table are explained below.

Item Number Column

Checks and services are numbered in chronological order regardless of interval. Use this column as the source of item number when recording PMCS results in the "TM Number" column on DA Form 2404, *Equipment Inspection and Maintenance Worksheet*.

**PMCS, INCLUDING LUBRICATION INSTRUCTIONS WORK
PACKAGE - Continued** **0007 00**

INTRODUCTION - Continued

Interval Column

The interval column tells you when to do a certain check or service.

Before - Perform required tasks before donning AIRSAVE.

During - Perform required tasks while wearing AIRSAVE.

After - Perform required tasks after doffing AIRSAVE.

Weekly - Perform required maintenance once a week.

Location/Item to Check/Service Column

The items listed in this column are identified by their common names.

Procedures Column

This column briefly describes the procedure to be checked. It contains all information required to accomplish the checks and services, including appropriate tolerances, adjustments and gauge readings.

Prior to Storage or Shipment

A complete PMCS will be performed prior to storage or shipment.

OPERATOR PREVENTIVE MAINTENANCE CHECKS AND
SERVICES (PMCS)

Table 1. PMCS for AIRSAVE.

ITEM NO.	INTER-VAL	MAN-HOUR	ITEM TO CHECK OR SERVICE	PROCEDURE	EQUIPMENT NOT READY/ AVAILABLE IF:
1	Before		LPFC	<p>WARNING</p> <p>Ensure that the beaded inflation handles are readily accessible. Beaded inflation handles shall be secured with six snap fasteners.</p> <p>CAUTION</p> <p>Do not open any sealed or safety-tied portion of the life preserver for Pre-Flight Inspection.</p>	

OPERATOR PREVENTIVE MAINTENANCE CHECKS AND SERVICES (PMCS) – Continued

Table 1. PMCS for AIRSAVE. - Continued

ITEM NO.	INTERVAL	MAN-HOUR	ITEM TO CHECK OR SERVICE	PROCEDURE	EQUIPMENT NOT READY/ AVAILABLE IF:
1	Before (Cont)		LPFC (Cont)	<p>a. Inspect exterior cover for cuts, tears, deterioration, abrasions, stains, cleanliness, security of stitching, and other signs of damage.</p> <p>b. Inspect snaps for secure attachment, corrosion, and ease of operation.</p> <p>c. Inspect safety-ties on beaded handles. Safety-ties may be replaced without removing LPFC from service.</p>	<p>Exterior cover is dirty or shows any sign of damage.</p> <p>Snaps are loose or damaged.</p>

OPERATOR PREVENTIVE MAINTENANCE CHECKS AND
 SERVICES (PMCS) – Continued

Table 1. PMCS for AIRSAVE. - Continued

ITEM NO.	INTER-VAL	MAN-HOUR	ITEM TO CHECK OR SERVICE	PROCEDURE	EQUIPMENT NOT READY/ AVAILABLE IF:
1	Before (Cont)		LPFC (Cont)	d. Inspect zipper closing for security throughout its length. e. Inspect plastic buckles and buckle straps for proper operation and security. Buckles may be replaced without removing LPFC from service. f. Inspect identification and warning labels for secure attachment.	Zipper does not fasten securely. Identification or warning label is loose.

TM 1-1680-361-10

PMCS, INCLUDING LUBRICATION INSTRUCTIONS WORK
PACKAGE - Continued 0007 00

**OPERATOR PREVENTIVE MAINTENANCE CHECKS AND
SERVICES (PMCS) – Continued**

Table 1. PMCS for AIRSAVE. - Continued

ITEM NO.	INTERVAL	MAN-HOUR	ITEM TO CHECK OR SERVICE	PROCEDURE	EQUIPMENT NOT READY/ AVAILABLE IF:
2	Before		HEED	a. Visually inspect for evidence of malfunctions or external damage. b. Inspect mouthpiece assembly for security and cleanliness.	HEED malfunctions or is damaged. Mouthpiece assembly is loose or dirty.

0007 00-6

TM 1-1680-361-10

PMCS, INCLUDING LUBRICATION INSTRUCTIONS WORK
PACKAGE - Continued 0007 00

OPERATOR PREVENTIVE MAINTENANCE CHECKS AND
SERVICES (PMCS) – Continued

Table 1. PMCS for AIRSAVE. - Continued

ITEM NO.	INTER-VAL	MAN-HOUR	ITEM TO CHECK OR SERVICE	PROCEDURE	EQUIPMENT NOT READY/ AVAILABLE IF:
2	Before (Cont)		HEED (Cont)	<p>WARNING</p> <p>When regulator ON/OFF valve is on and HEED is under pressure, ensure pressure indicator pin is directed away from face and exposed body parts. Should internal structural failure of pressure indicator pin occur, ejected fragments of pin could cause serious personal injury.</p>	

0007 00-7

OPERATOR PREVENTIVE MAINTENANCE CHECKS AND SERVICES (PMCS) – Continued

Table 1. PMCS for AIRSAVE. - Continued

ITEM NO.	INTER-VAL	MAN-HOUR	ITEM TO CHECK OR SERVICE	PROCEDURE	EQUIPMENT NOT READY/ AVAILABLE IF:
2	Before (Cont)		HEED (Cont)	<p>c. Turn ON/OFF valve on and check to ensure cylinder has adequate air pressure. Pressure indicator pin should be flush with or above the notch indicating a charge of at least 1500 psi (minimum limit permitted for flight).</p> <p>NOTE The ON/OFF valve shall remain on until termination of the flight.</p>	Air pressure in cylinder is less than 1500 psi.

TM 1-1680-361-10

**PMCS, INCLUDING LUBRICATION INSTRUCTIONS WORK
PACKAGE - Continued**

0007 00

**OPERATOR PREVENTIVE MAINTENANCE CHECKS AND
SERVICES (PMCS) – Continued**

Table 1. PMCS for AIRSAVE. - Continued

ITEM NO.	INTERVAL	MAN-HOUR	ITEM TO CHECK OR SERVICE	PROCEDURE	EQUIPMENT NOT READY/ AVAILABLE IF:
2	Before (Cont)		HEED (Cont)	d. Manually purge regulator by momentarily depressing purge button. Listen for an audible hiss as air vents through the mouthpiece. The sound should cease immediately when purge button is released. If vented air does not stop immediately, depress purge button 3 or 4 more times. If vented air stops, proceed with inspection.	Vented air does not stop or no audible hiss is heard when purge button is depressed. Forward HEED to ALSE shop for repair.

0007 00-9

OPERATOR PREVENTIVE MAINTENANCE CHECKS AND
SERVICES (PMCS) – Continued

Table 1. PMCS for AIRSAVE. - Continued

ITEM NO.	INTER-VAL	MAN-HOUR	ITEM TO CHECK OR SERVICE	PROCEDURE	EQUIPMENT NOT READY/ AVAILABLE IF:
2	Before (Cont)		HEED (Cont)	e. Check HEED-to-survival vest or HEED-to-holster retaining lanyard for security of attachment. Ensure quick disconnect capability has been incorporated.	Lanyard is not securely attached or quick disconnect capability has not been incorporated.
3	Before		SRT	a. Visually inspect SRT for areas of webbing that are worn, melted, frayed, cut, or soaked with POL. Replace SRT if any of these conditions exists.	Webbing is worn, melted, frayed, cut, or soaked with POL.

TM 1-1680-361-10

**PMCS, INCLUDING LUBRICATION INSTRUCTIONS WORK
PACKAGE - Continued**
0007 00

**OPERATOR PREVENTIVE MAINTENANCE CHECKS AND
SERVICES (PMCS) – Continued**

Table 1. PMCS for AIRSAVE. - Continued

ITEM NO.	INTER-VAL	MAN-HOUR	ITEM TO CHECK OR SERVICE	PROCEDURE	EQUIPMENT NOT READY/ AVAILABLE IF:
3	Before (Cont)		SRT (Cont)	b. Check the bar tack stitching where the webbing has been sewn together to form the loop. There should be 6 bar tacks. If any of the bar tack stitches have loosened or are missing, replace the SRT.	Any bar tack is missing or stitching is loose.

0007 00-11

OPERATOR PREVENTIVE MAINTENANCE CHECKS AND SERVICES (PMCS) – Continued

ITEM NO.	INTER-VAL	MAN-HOUR	ITEM TO CHECK OR SERVICE	PROCEDURE	EQUIPMENT NOT READY/ AVAILABLE IF:
4	After		HEED	<p>WARNING</p> <p>When regulator ON/OFF valve is on and HEED is under pressure, ensure pressure indicator pin is directed away from face and exposed body parts. Should internal structural failure of pressure indicator pin occur, ejected fragments of pin could cause serious personal injury.</p> <p>a. Check pressure indicator pin to ensure pin is above notch (indicating at least 1500 psi).</p>	Pressure is less than 1500 psi.

TM 1-1680-361-10

PMCS, INCLUDING LUBRICATION INSTRUCTIONS WORK
PACKAGE - Continued 0007 00

OPERATOR PREVENTIVE MAINTENANCE CHECKS AND
SERVICES (PMCS) – Continued

Table 1. PMCS for AIRSAVE. - Continued

ITEM NO.	INTER-VAL	MAN-HOUR	ITEM TO CHECK OR SERVICE	PROCEDURE	EQUIPMENT NOT READY/ AVAILABLE IF:
4	After (Cont)		HEED (Cont)	<p>CAUTION</p> <p>Do not use force when closing ON/OFF valve. Excess force may cause damage to soft seating surface. Close finger-tight only.</p> <p>b. Turn ON/OFF valve off, finger-tight.</p> <p>c. Bleed air from regulator by depressing purge button until air flow stops.</p>	

0007 00-13

TM 1-1680-361-10

PMCS, INCLUDING LUBRICATION INSTRUCTIONS WORK
PACKAGE - Continued
0007 00

OPERATOR PREVENTIVE MAINTENANCE CHECKS AND
SERVICES (PMCS) – Continued

Table 1. PMCS for AIRSAVE. - Continued

ITEM NO.	INTER-VAL	MAN-HOUR	ITEM TO CHECK OR SERVICE	PROCEDURE	EQUIPMENT NOT READY/ AVAILABLE IF:
4	After (Cont)		HEED (Cont)	d. Inspect HEED for external damage. e. Inspect mouthpiece for cleanliness and security. f. Inspect regulator for cleanliness and signs of salt air/water contamination.	HEED shows external damage. Mouthpiece is dirty or loose. Regulator is dirty or contaminated.
5	After		SRT	a. Visually inspect SRT for areas of webbing that are worn, melted, frayed, cut, or soaked with POL. Replace SRT if any of these conditions exists.	Webbing is worn, melted, frayed, cut, or soaked with POL.

0007 00-14

TM 1-1680-361-10

PMCS, INCLUDING LUBRICATION INSTRUCTIONS WORK PACKAGE - Continued
0007 00

OPERATOR PREVENTIVE MAINTENANCE CHECKS AND SERVICES (PMCS) – Continued

Table 1. PMCS for AIRSAVE. - Continued

ITEM NO.	INTERVAL	MAN-HOUR	ITEM TO CHECK OR SERVICE	PROCEDURE	EQUIPMENT NOT READY/ AVAILABLE IF:
5	After (Cont)		SRT (Cont)	<p>b. Check the bar tack stitching where webbing has been sewn together to form the loop. There should be 6 bar tacks. If any of the bar tack stitches have loosened or are missing, replace the SRT.</p> <p>c. Inspect SRT for cleanliness. If SRT has become soiled, clean as indicated in WP 0009 00.</p>	Any bar tack is missing or stitching is loose.

0007 00-15

 OPERATOR PREVENTIVE MAINTENANCE CHECKS AND
 SERVICES (PMCS) – Continued

Table 1. PMCS for AIRSAVE. - Continued

ITEM NO.	INTER-VAL	MAN-HOUR	ITEM TO CHECK OR SERVICE	PROCEDURE	EQUIPMENT NOT READY/ AVAILABLE IF:
6	Every 90 Days		Vest	a. Inspect all survival items. b. Ensure all pockets are securely fastened to vest. c. Inspect fabric for cuts, tears, and abrasions. d. Inspect stitching for security. e. Inspect pocket and snap fasteners for secure attachment and closure.	Missing items. Loose pockets. Cut, torn, or abraded fabric. Loose stitching. Loose or insecure pocket or snap fasteners.

TM 1-1680-361-10

PMCS, INCLUDING LUBRICATION INSTRUCTIONS WORK PACKAGE - Continued
0007 00

OPERATOR PREVENTIVE MAINTENANCE CHECKS AND SERVICES (PMCS) – Continued

Table 1. PMCS for AIRSAVE. - Continued

ITEM NO.	INTERVAL	MAN-HOUR	ITEM TO CHECK OR SERVICE	PROCEDURE	EQUIPMENT NOT READY/ AVAILABLE IF:
6	Every 90 Days (Cont)		Vest (Cont)	<p>f. Ensure required survival items are present and securely attached.</p> <p>g. Inspect slide fastener for damage, security, and ease of operation.</p> <p>h. Verify overall condition of survival vest.</p>	<p>Required survival items are missing or insecurely attached.</p> <p>Slide fastener damaged, loose, or hard to operate.</p> <p>Vest shows wear or damage.</p>

0007 00-17

TM 1-1680-361-10

PMCS, INCLUDING LUBRICATION INSTRUCTIONS WORK
PACKAGE - Continued 0007 00

OPERATOR PREVENTIVE MAINTENANCE CHECKS AND
SERVICES (PMCS) – Continued

Table 1. PMCS for AIRSAVE. - Continued

ITEM NO.	INTER-VAL	MAN-HOUR	ITEM TO CHECK OR SERVICE	PROCEDURE	EQUIPMENT NOT READY/ AVAILABLE IF:
6	Every 90 Days (Cont)		Vest (Cont)	i. Ensure inspection is completed and corrective action has been taken on any discrepancies found. j. If cleaning is required, clean in accordance with WP 0008 00.	

0007 00-18

OPERATOR MAINTENANCE WORK PACKAGE 0008 00

THIS WORK PACKAGE COVERS:

Cleaning and Preparation for Storage or Shipment procedures.

INITIAL SETUP:

Maintenance Level:

Operator

Materials/Parts:

Detergent, General Purpose MIL-D-16791

SURVIVAL VEST CLEANING

1. Ensure all survival items are removed from vest.
2. Immerse vest in detergent solution and allow to soak for 5 minutes. Agitate gently with hands for 2 minutes, then remove from solution and allow to drain; do not wring.
3. Rinse vest in cool, fresh water until all traces of detergent are gone.

CAUTION

Do not use dryer. Do not hang in direct sunlight.

4. Hang vest on wooden hanger in a well-ventilated area until dry. Do not iron or press.

**OPERATOR MAINTENANCE WORK PACKAGE –
Continued**

0008 00

SOFT BALLISTIC INSERTS CLEANING

1. Remove soft ballistic insert assemblies from the casing assembly.

WARNING

Do not soak soft ballistic inserts or use bleach or starch. Do not use hot water, high heat, or fabric softener. High heat will cause shrinkage.

2. Use only a damp cloth to wipe the soft ballistic insert cover until clean.

WARNING

Do not leave ballistic aramid cloth exposed to direct sunlight. Continuous exposure to ultraviolet rays for an extensive period of time will seriously deteriorate the soft armor.

3. Allow to dry in open, well-ventilated area.

**OPERATOR MAINTENANCE WORK PACKAGE –
Continued**

0008 00

**HARD BALLISTIC INSERTS/ARMY .50 CALIBER PLATE
CLEANING**

1. Remove the hard ballistic armor inserts from their encasements/carrier.
2. Wipe clean with a damp cloth.
3. Dry with a cloth/paper towel or set to air dry.

**CASING AND ENCASEMENT ASSEMBLIES AND .50
CALIBER CARRIER CLEANING**

In the following procedures use of the term “casing assembly” will include the soft armor casing assembly, the hard armor encasement, and the .50 caliber carrier.

WARNING

Remove all soft ballistic insert assemblies prior to washing the casing assembly. Ballistic inserts can be cleaned with soft brush and water. Hang dry away from sunlight and direct heat.

**OPERATOR MAINTENANCE WORK PACKAGE –
Continued**

0008 00

**CASING AND ENCASEMENT ASSEMBLIES AND .50
CALIBER CARRIER CLEANING - Continued**

1. Ensure all soft ballistic insert assemblies have been removed.
2. Remove loose dirt from hook and pile fastener and outer cover surface using a cloth or soft brush. Do not use a stiff bristle brush.
3. Fasten the hook and pile to prevent entangling with other articles.

WARNING

JP-5 fuel, grease or other combustibles embedded in casing assembly fabric will burn at their normal flash points even though the aramid cloth will not burn until a higher temperature is reached. Be sure the casing assembly is thoroughly clean and free of combustibles prior to further use. Machine wash or hand wash as necessary with mild detergent and warm water.

CAUTION

Do not use hot water, high heat, or fabric softener. High heat will cause shrinkage.

**OPERATOR MAINTENANCE WORK PACKAGE –
Continued**

0008 00

**CASING AND ENCASEMENT ASSEMBLIES AND .50
CALIBER CARRIER CLEANING - Continued**

4. Immerse casing assembly in a proper mixture of a commercial laundry detergent and lukewarm water. Allow casing assembly to soak for 5 minutes and drain water.
5. Rinse casing assembly in cool, fresh water and drain the water. Repeat rinsing until all traces of detergent have disappeared from the rinse water.

CAUTION

Do not dry casing assembly in direct sunlight.

6. Hang casing assembly on a wooden hanger to dry in a dry, well-ventilated area away from heat and any open flame.

SRT CLEANING

1. Clean with mild soap or detergent and warm or cold water.
2. Air-dry for maximum strength retention.

TM 1-1680-361-10

**OPERATOR MAINTENANCE WORK PACKAGE –
Continued**

0008 00

PREPARATION FOR STORAGE OR SHIPMENT

Refer to TM 38-230-1, *Packaging of Materiel: Preservation (Volume 1)*, and TM 38-230-2, *Packaging of Materiel: Packing (Volume 2)*. The SRT will be stowed in one of the general pockets of the AIRSAVE vest in accordance with the aviation unit's Standard Operating Procedures.

END OF TASK

0008 00-6

CHAPTER 4

SUPPORTING INFORMATION

REFERENCES WORK PACKAGE

0009 00

This work package lists other documents referenced in this manual.

FORMS

Equipment Inspection and Maintenance Worksheet	DA Form 2404
Product Quality Deficiency Report	SF 368
Recommended Changes to Publications and Blank Forms	DA Form 2028

TECHNICAL MANUALS

Aircrew Personal Protective Equipment (Protective Assembly, Aircrew Survival – Armor A/P22P-18(V)).....	TM 1-1680-360-12, NAVAIR 13-1-6.7-4
Aviation Unit and Aviation Intermediate Maintenance Manual with Repair Parts and Special Tools List for Army Aircraft Survival Kits.....	TM 55-1680-317-23&P
Operators Manual for Aircrew Survival Armor Recovery Vest, Insert, and Packets (SARVIP)	TM 1-1680-359-10
Packaging of Materiel: Packing (Volume 2)	TM 38-230-2

REFERENCES WORK PACKAGE - Continued 0009 00

TECHNICAL MANUALS - Continued

Packaging of Materiel: Preservation
 (Volume 1)..... TM 38-230-1
Procedures for Destruction of Life Support
 Equipment to Prevent Enemy Use TM 750-244-1-2

OTHER

Army Medical Department
 Expendable/Durable Items..... CTA 8-100
Clothing and Individual Equipment..... CTA 50-900
Expendable/Durable Items
 (Except Medical, Class V, Repair Parts,
 and Heraldic Items CTA 50-970
First Aid For Soldiers FM 21-11
Functional Users Manual for
 the Army Maintenance
 Management System (TAMMS)..... DA PAM 738-750
Functional Users Manual for the Army
 Maintenance Management
 System – Aviation TAMMS-A) DA PAM 738-751

**COMPONENTS OF END ITEM (COEI) AND BASIC ISSUE
ITEMS (BII) LISTS WORK PACKAGE** **0010 00**

INTRODUCTION

Scope

This work package lists COEI and BII for the AIRSAVE to help you inventory items for safe and efficient operation of the equipment.

General

The COEI and BII information is divided into the following lists:

The Components of End Item (COEI) list is for information purposes only and is not authority to requisition replacements. These items are part of the AIRSAVE. As part of the end item, these items must be with the end item whenever it is issued or transferred between property accounts. Items of COEI are removed and separately packaged for transportation or shipment only when necessary. Illustrations are furnished to help you find and identify the items.

The Basic Issue Items (BII) list shows essential items required to place the AIRSAVE in operation, to operate it, and to do emergency repairs. Although shipped separately packaged, BII must be with the AIRSAVE during operation and when it is transferred between property accounts. Listing these items is your authority to request/requisition them for replacement based on authorization of the end item by the CTA. Illustrations are furnished to help you find and identify the items.

**COMPONENTS OF END ITEM (COEI) AND BASIC ISSUE
ITEMS (BII) LISTS WORK PACKAGE - Continued 0010 00**

INTRODUCTION - Continued

Explanation of Columns in the COEI List and BII List

Column (1) - Illus Number gives you the number of the item illustrated.

Column (2) - National Stock Number (NSN) identifies the stock number of the item to be used for requisitioning purposes.

Column (3) - Description, CAGEC, and Part Number identifies the Federal item name (in all capital letters) followed by a minimum description when needed. The stowage location of COEI and BII is also included in this column. The last line below the description is the CAGEC (commercial and Government entity code) (in parentheses) and the part number.

Column (4) - Usable On Code, when applicable, gives you a code if the item you need is not the same for different models of equipment.

Column (5) - Unit of Measure (U/M) indicates the physical measurement or count of the item as issued per the National Stock Number shown in column (2).

Column (6) - Qty Rqr indicates the quantity required.

**COMPONENTS OF END ITEM (COEI) AND BASIC ISSUE
ITEMS (BII) LISTS WORK PACKAGE - Continued 0010 00**

COMPONENTS OF END ITEM LIST

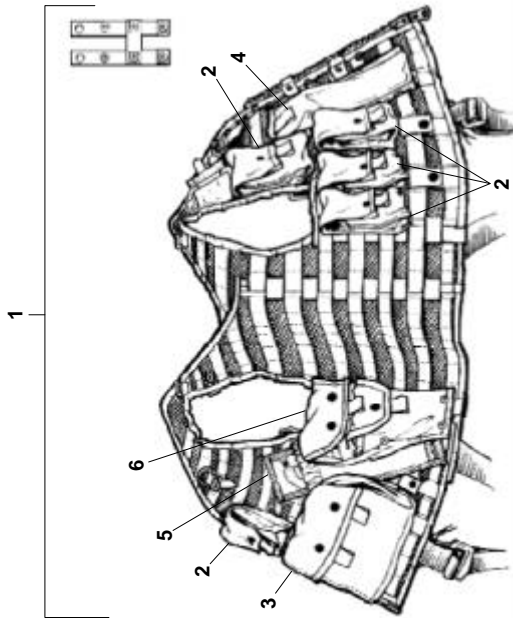

TM 1-1680-361-10

**COMPONENTS OF END ITEM (COEI) AND BASIC ISSUE
ITEMS (BIU) LISTS WORK PACKAGE - Continued 0010 00**

COMPONENTS OF END ITEM LIST - Continued

Table 1. Components of End Item List.

(1) ILLUST NO.	(2) NATIONAL STOCK NUMBER	(3) DESCRIPTION, CAGEC, AND PART NUMBER	(4) USABLE ON CODE	(5) U/M	(6) QTY RQR
1	8415-01-442-1991	Vest, Survival, Aircrewman's (AIRSAVE), Type I, w/harness (81349) MIL-DTL-29611		EA	1
2	8415-01-442-1988	Vest, Survival, Aircrewman's (AIRSAVE), General Pocket (81349) MIL-DTL-29611		EA	5
3	8415-01-441-1693	Vest, Survival, Aircrewman's (AIRSAVE), Radio Pocket (81349) MIL-DTL-29611		EA	1

0010 00-4

TM 1-1680-361-10

COMPONENTS OF END ITEM (COEI) AND BASIC ISSUE
ITEMS (BI) LISTS WORK PACKAGE - Continued 0010 00

COMPONENTS OF END ITEM LIST - Continued

Table 1. Components of End Item List - Continued

(1) ILLUST NO.	(2) NATIONAL STOCK NUMBER	(3) DESCRIPTION, CAGEC, AND PART NUMBER	(4) USABLE ON CODE	(5) U/M	(6) QTY RQR
4	8415-01-441-3298	Vest, Survival, Aircrewman's (AIRSAVE), Knife Pocket (81349) MIL-DTL-29611		EA	1
5	8415-01-441-3294	Vest, Survival, Aircrewman's (AIRSAVE), HEED Pocket for SRU-36/P (Optional) (81349) MIL-DTL-29611		EA	Opt
5	8415-01-441-3293	Vest, Survival, Aircrewman's (AIRSAVE), HABD Pocket for SRU-40/P (Optional) (81349) MIL-DTL-29611		EA	Opt
6	8415-01-441-3299	Vest, Survival, Aircrewman's (AIRSAVE), Pistol Pocket (81349) MIL-DTL-29611		EA	Opt

0010 00-5

TM 1-1680-361-10

**COMPONENTS OF END ITEM (COEI) AND BASIC ISSUE
ITEMS (BII) LISTS WORK PACKAGE - Continued 0010 00**

COMPONENTS OF END ITEM LIST – Continued

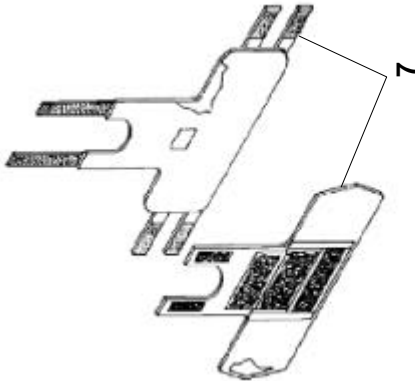

0010 00-6

TM 1-1680-361-10

COMPONENTS OF END ITEM (COEI) AND BASIC ISSUE
ITEMS (BI) LISTS WORK PACKAGE - Continued 0010 00

COMPONENTS OF END ITEM LIST - Continued

Table 1. Components of End Item List - Continued

(1) ILLUST NO.	(2) NATIONAL STOCK NUMBER	(3) DESCRIPTION, CAGEC, AND PART NUMBER	(4) USABLE ON CODE	(5) U/M	(6) QTY RQR
7	8470-01-441- 2993(S)	Body Armor, Soft, Small Arms Protective, PRU-60A/ P22P (Set) (size: Medium) (81349) MIL-B-29605		EA	1
7	8470-01-441- 2996(S)	Body Armor, Soft, Small Arms Protective, PRU-60A/ P22P (Set) (size: Large) (81349) MIL-B-29605		EA	1

0010 00-7

TM 1-1680-361-10

**COMPONENTS OF END ITEM (COEI) AND BASIC ISSUE
ITEMS (BII) LISTS WORK PACKAGE - Continued 0010 00**

COMPONENTS OF END ITEM LIST – Continued

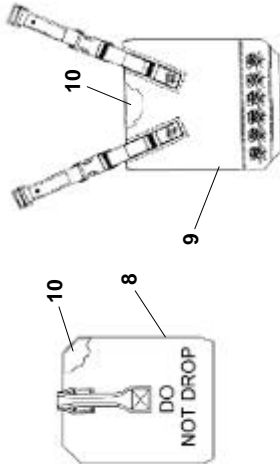

0010 00-8

TM 1-1680-361-10

COMPONENTS OF END ITEM (COEI) AND BASIC ISSUE
ITEMS (BI) LISTS WORK PACKAGE - Continued 0010 00

COMPONENTS OF END ITEM LIST - Continued

Table 1. Components of End Item List - Continued

(1) ILLUST NO.	(2) NATIONAL STOCK NUMBER	(3) DESCRIPTION, CAGEC, AND PART NUMBER	(4) USABLE ON CODE	(5) U/M	(6) QTY RQR
8	8470-01-441- 2986(S)	Body Armor, Hard, Small Arms Protective, PRU-61A/ P22P (Front Assy) (size: Medium) (81349) MIL-B-29604		EA	1
8	8470-01-442- 2062(S)	Body Armor, Hard, Small Arms Protective, PRU-61A/ P22P (Front Assy) (size: Large) (81349) MIL-B-29604		EA	1

0010 00-9

TM 1-1680-361-10

COMPONENTS OF END ITEM (COEI) AND BASIC ISSUE
ITEMS (BIJ) LISTS WORK PACKAGE - Continued 0010 00

COMPONENTS OF END ITEM LIST - Continued

Table 1. Components of End Item List - Continued

(1) ILLUST NO.	(2) NATIONAL STOCK NUMBER	(3) DESCRIPTION, CAGEC, AND PART NUMBER	(4) USABLE ON CODE	(5) U/M	(6) QTY RQR
9	8470-01-441- 2991(S)	Body Armor, Hard, Small Arms Protective, PRU-61A/ P22P (Back Assy) (size: Medium) (81349) MIL-B-29604		EA	1
9	8470-01-442- 1990(S)	Body Armor, Hard, Small Arms Protective, PRU-61A/ P22P (Back Assy) (size: Large) (81349) MIL-B-29604		EA	1

0010 00-10

TM 1-1680-361-10

**COMPONENTS OF END ITEM (COEI) AND BASIC ISSUE
ITEMS (BIU) LISTS WORK PACKAGE - Continued 0010 00**

COMPONENTS OF END ITEM LIST - Continued

Table 1. Components of End Item List - Continued

(1) ILLUST NO.	(2) NATIONAL STOCK NUMBER	(3) DESCRIPTION, CAGEC, AND PART NUMBER	(4) USABLE ON CODE	(5) U/M	(6) QTY RQR
10	8470-01-441-2995	Insert, Body Armor, Hard, Small Arms Protective, PRU-61A/P22P (For Front or Back Assy) (size: Medium) (81349) MIL-B-29604		EA	1
10	8470-01-441-2997	Insert, Body Armor, Hard, Small Arms Protective, PRU-61A/P22P (For Front or Back Assy) (size: Large) (81349) MIL-B-29604		EA	1

0010 00-11

TM 1-1680-361-10

COMPONENTS OF END ITEM (COEI) AND BASIC ISSUE ITEMS (BI) LISTS WORK PACKAGE - Continued 0010 00

BASIC ISSUE ITEMS LIST

<input type="radio"/>	TM 1-1680-361-10
<input type="radio"/>	TECHNICAL MANUAL
<input type="radio"/>	OPERATOR'S MANUAL
<input type="radio"/>	FOR
<input type="radio"/>	AIRCREW INTEGRATED RECOVERY
<input type="radio"/>	SURVIVAL ARMOR VEST AND
<input type="radio"/>	EQUIPMENT (AIRSAVE)
<input type="radio"/>	NSN 8415-01-442-1991
<input type="radio"/>	NSN 8470-01-441-2993(S)
<input type="radio"/>	MSM 8470-01-441-2980(S)
<input type="radio"/>	NSN 8470-01-442-2062(S)
<input type="radio"/>	DISTRIBUTION STATEMENT A: Approved for public release; distribution is unlimited.
<input type="radio"/>	HEADQUARTERS,
<input type="radio"/>	DEPARTMENT OF THE ARMY
<input type="radio"/>	DATE

Table 2. Basic Issue Items List.

(1) ILLUST NO.	(2) NATIONAL STOCK NUMBER	(3) DESCRIPTION, CAGEC, AND PART NUMBER	(4) USABLE ON CODE	(5) U/M	(6) QTY RQR
1		TM 1-1680-361-10 Operator's Manual for Aircrew Integrated Recovery Survival Armor Vest and Equipment (AIRSAVE)		1	1

0010 00-12

**ADDITIONAL AUTHORIZATION LIST (AAL) WORK
PACKAGE**

0011 00

INTRODUCTION

Scope

This work package lists additional items you are authorized for the support of the AIRSAVE.

General

This list identifies items that do not have to accompany the AIRSAVE and that do not have to be turned in with it. These items are all authorized to you by CTA, MTOE, TDA, or JTA.

Explanation of Columns in the AAL

Column (1) - National Stock Number (NSN). Identifies the stock number of the item to be used for requisitioning purposes.

Column (2) - Description, Commercial and Government Entity Code (CAGEC), and Part Number (P/N). Identifies the Federal item name (in all capital letters) followed by a minimum description when needed. The last line below the description is the CAGEC (in parentheses) and the part number.

Column (3) - Usable On Code. When applicable, gives you a code if the item you need is not the same for different models of equipment.

These codes are identified below:

Code
XXX

Used on
Model XXX

Column (4) - Unit of Measure (U/M). Indicates the physical measurement or count of the item as issued per the National Stock Number shown in column (1).

Column (5) - Qty Recm. Indicates the quantity recommended.

TM 1-1680-361-10

ADDITIONAL AUTHORIZATION LIST (AAL) WORK PACKAGE - Continued

0011 00

Table 1. Additional Authorization List for AIRSAVE.

(1) NATIONAL STOCK NUMBER	(2) DESCRIPTION, CAGEC, AND PART NUMBER	(3) USABLE ON CODE	(4) U/M	(5) QTY RECM
TBD	Low-Profile Flotation Collar (LPFC) LPU-34/P (05DK2) 830AS250-1		EA	1
8470-01-359-0426 8470-01-359-0427 8470-01-359-0428 8470-01-359-0429	Carrier, Small Arms Protective Body Armor (.50 Caliber Hard Armor) (81349) MIL-C-44417 Short Regular Long X-Long		EA	1
TBD	Safety Restraint Tether (SRT) (66165) SS1DR		EA	1
1660-01-240-8316	Egress Device, Vest (HEED), SRU-36/P (30003) 1586AS101-11		EA	1

0011 00-2

TM 1-1680-361-10

**ADDITIONAL AUTHORIZATION LIST (AAL) WORK
PACKAGE - Continued**

0011 00

**Table 1. Additional Authorization List for AIRSAVE. -
Continued**

(1) NATIONAL STOCK NUMBER	(2) DESCRIPTION, CAGEC, AND PART NUMBER	(3) USABLE ON CODE	(4) U/M	(5) QTY RECM
4220-01-120-4894	Life Preserver, Yoke LPU-21/P (30003) 68A73H1-101		EA	1
4220-00-850-8655	Life Preserver, Underarm, LPU-10/P (80049) LPU-10/P			
4220-01-272-8004	Life Raft, Inflatable, LRU-18/U (30003) 1521AS102-1		EA	1
	Selected Survival Items (TM 1-1680-360-12, NAVAIR 13-1-6.7-4, Appendix A)			

0011 00-3/4 blank

[

]

L

]

**EXPENDABLE AND DURABLE ITEMS LIST WORK
PACKAGE**

0012 00

INTRODUCTION

Scope

This work package lists expendable and durable items that you will need to operate and maintain the AIRSAVE. This list is for information only and is not authority to requisition the listed items. These items are authorized to you by CTA 50-970, Expendable/Durable Items (Except Medical, Class V, Repair Parts, and Heraldic Items) or CTA 8-100, Army Medical Department Expendable/Durable Items.

Explanation of Columns in the Expendable/Durable Items List

Column (1) — Item Number. This number is assigned to the entry in the list and is referenced in the narrative instructions to identify the item (e.g., Use brake fluid (item 5, WP 0098 00)).

Column (2) — Level. This column identifies the lowest level of maintenance that requires the listed item:

C - Operator/Crew

Column (3) — National Stock Number (NSN). This is the NSN assigned to the item which you can use to requisition it.

Column (4) — Item Name, Description, Commercial and Government Entity Code (CAGEC), and Part Number (P/N). This column provides the other information you need to identify the item.

**EXPENDABLE AND DURABLE ITEMS LIST WORK
PACKAGE - Continued**

0012 00

INTRODUCTION - Continued

**Explanation of Columns in the Expendable/Durable Items
List - Continued**

Column (5)— Unit of Measure (U/M). This code shows the physical measurement or count of an item, such as gallon, dozen, gross, etc.

EXPENDABLE AND DURABLE ITEMS LIST

Table 1. Expendable and Durable Items List.

(1) ITEM NO.	(2) LEVEL	(3) NATIONAL STOCK NUMBER	(4) ITEM NAME, DESCRIPTION, CAGEC AND PART NUMBER	(5) U/M
1	C		Detergent, General Purpose MIL-D-16791	

EMERGENCY EVACUATION PROCEDURES: USING THE SAFETY RESTRAINT TETHER **0013 00**

The Safety Restraint Tether (SRT) is to be used (during emergency situations) when a downed aircrew member has to be evacuated by a rotary-wing aircraft with limited interior space and no other aircraft is available to perform the pickup. The aircrew member will attach him/her self to the aircraft by attaching one end of the SRT to the approved hard point located on the aircraft and the other end to his/her survival vest extraction harness (snaplink) attachment point. Currently, the only aircraft that have been identified for use with the SRT are the AH-1F, AH-64A and OH-58D(I).

WARNING

- Never approach an operating rotary-wing aircraft from the rear! Death or severe injury could occur if the pilot does not see you and rotates the aircraft. Always approach an operating aircraft from the front or side and only when signaled to do so by the pilot or crewmember. Minimize exposure to the front of any weapons systems.
- Pilots must take into consideration lateral center of gravity (CG) when attempting any externally carried rescue. Pilot must retain enough cyclic force to counter the weight of the rescuee. Externally carried rescues will be flown the shortest practical distance to remove the rescuee from immediate extreme danger.

**EMERGENCY EVACUATION PROCEDURES: USING THE
SAFETY RESTRAINT TETHER – Continued** **0013 00**

WARNING

- Pilots should limit forward airspeed to 60 knots and only exceed this speed if required by the tactical situation. Pilots/crew should monitor the status of the rescuee. If the rescuee falls from his/her seating he/she will be retained by the SRT, however the rescuee's lower body/legs may be lower than the landing gear. Ensure he/she is clear of the landing gear before landing.
- The Safety Restraint Tether is **ONLY FOR USE IN EMERGENCY SITUATIONS** and must be kept in serviceable condition. Aircrew practice of SRT attachment to the aircraft will be limited to non-operating aircraft, fully parked in an approved landing or tiedown area. The SRT is intended to be used with the extraction harness of the AIRSAVE (or the SARVIP and the SRU-21/P when modified with extraction harness). Use with other systems may result in injury.
- The Safety Restraint Tether has a rated strength of 3000 pounds and a one-time pull test strength of 5000 pounds. Do not use the tether if any of the bar tacks is loose, frayed, or missing. Do not use the tether if the nylon webbing is worn, frayed, cut, or has been soaked by POL products. Turn it in and get a new tether.

**EMERGENCY EVACUATION PROCEDURES: USING THE
SAFETY RESTRAINT TETHER – Continued** 0013 00

AH-1F, Cobra



1. On the AH-1F, the right-side or left-side ammunition bay doors can be lowered. Ensure the ammo canisters are securely locked in place.
2. Attach the SRT to the forward handle of the 20mm ammunition container by looping the SRT through the handle and pulling the loop snug.
3. Sit on the open door, facing outward, bracing feet on the aircraft skid.

**EMERGENCY EVACUATION PROCEDURES: USING THE
SAFETY RESTRAINT TETHER – Continued** **0013 00**

AH-1F, Cobra - Continued

4. Attach the other end of the SRT to the Snaplink on the AIRSAVE vest extraction harness.
5. Depending on seating position and your size, use any safe method (such as doubling-over the SRT) to obtain as stable an attachment to the aircraft as possible. Use available uninjured hands for additional bracing and once you have obtained the most stable position possible, signal the pilot your readiness for liftoff. Optional: If two SRTs are available, you may attach yourself to both the front and rear handles of the 20mm ammunition canister.



**EMERGENCY EVACUATION PROCEDURES: USING THE
SAFETY RESTRAINT TETHER – Continued** 0013 00

AH-64A, Apache

Attaching points on the AH-64A are: right-side handhold located just aft of the pilot's door; and left-side center step just aft of the pilot's left window.

1. For attachment to the right side, sit on the right forward avionics bay (FAB) with your back against the leading edge of the wing support.
2. Double-over the SRT, loop it through the handhold, and attach the SRT to the snaplink on the AIRSAVE vest extraction harness.



**EMERGENCY EVACUATION PROCEDURES: USING THE
SAFETY RESTRAINT TETHER – Continued** **0013 00**

AH-64A, Apache - Continued

3. Use the handhold, taut SRT, and wing support for hand/arm/back bracing points and the lower step and the top of the FAB for foot/leg bracing points.
4. For attachment to the left side, sit on the left (FAB) with your back against the leading edge of the wing support.
5. Double-over the SRT, loop it through the center step and attach the SRT to the snaplink on the AIRSAVE vest extraction harness.



**EMERGENCY EVACUATION PROCEDURES: USING THE
SAFETY RESTRAINT TETHER – Continued 0013 00**

AH-64A, Apache - Continued

6. Use the top step, taut SRT, and wing support for hand/arm/back bracing points and the lower step and the top of the FAB for foot/leg bracing points.
7. Once you have obtained the most stable position possible, then signal the pilot your readiness for liftoff.

OH-58D(I), Kiowa

WARNING

OH-58D(I) pilots must take into consideration lateral center of gravity (CG) when attempting any externally carried rescue. Pilot must retain enough cyclic force to counter the weight of the rescuee.

On the OH-58D(I), the attaching points are the hard-points on the left-wing and right-wing “stores attachment racks.”

1. Sit straddling the weapon launcher, facing the rear of the aircraft.
2. Loop the SRT around the hard-point and attach the ends to the snaplink on the AIRSAVE vest extraction harness.

**EMERGENCY EVACUATION PROCEDURES: USING THE
SAFETY RESTRAINT TETHER – Continued** **0013 00**

OH-58D(I), Kiowa

3. For additional security lean forward over the weapon launcher and grasp the hard-point and the launcher to stabilize your position.
4. Once you have obtained the most stable position possible, then signal the pilot your readiness for liftoff.



ALPHABETICAL INDEX

WP Sequence Number-Page No.

A

Abbreviations and Acronyms, List of	0001 00-4
Additional Authorization List (AAL) Work Package	0011 00-1
Additional Authorization List for AIRSAVE	0011 00-2
AIRSAVE Donning Procedures (Type I).....	0005 00-2
AIRSAVE Modular Pockets, Operation	0006 00-1
AIRSAVE Vest and Modular Pocket Attachment.....	0002 00-5
Assembly and Preparation for Use	0005 00-1
Auxiliary Equipment, Operating Under Usual Conditions.....	0006 00-1

B

Ballistic Inserts, Hard, Cleaning	0008 00-3
Ballistic Inserts, Soft, Cleaning	0008 00-2
Basic Issue Items List.....	0010 00-12
Body Armor Assembly, .50 Caliber (See .50 Caliber Hard Body Armor Assembly)	
Body Armor Assembly, Hard (See Hard Body Armor Assembly)	
Body Armor Assembly, Soft (See Soft Body Armor Assembly)	

C

Capabilities, Equipment	0002 00-1
Carrier, .50 Caliber, Cleaning	0008 00-3
Casing and Encasement Assemblies Cleaning	0008 00-3
Characteristics, Equipment	0002 00-1

ALPHABETICAL INDEX - Continued

WP Sequence Number-Page No.

C - Continued

Cleaning:	
Casing and Encasement Assemblies	0008 00-3
.50 Caliber Carrier.....	0008 00-3
.50 Caliber Plate	0008 00-3
Hard Ballistic Inserts.....	0008 00-3
Soft Ballistic Inserts	0008 00-2
SRT	0008 00-5
Survival Vest	0008 00-1
Components, Location and Description of Major.....	0002 00-5
Components of End Item(COEI) and Basic Issue	
Items (BII) Lists Work Package.....	0010 00-1
Components of End Item List	0010 00-3
Conditions, Operation Under Usual.....	0005 00-1
Contents, Table of.....	iii
Controls and Indicators, Operator.....	0004 00-1
Corrosion Prevention and Control (CPC).....	0001 00-2

D

Data, Equipment.....	0002 00-11
Description and Use of Operator Controls and	
Indicators Work Package.....	0004 00-1
Description, Equipment	0002 00-1
Destruction of Army Materiel to Prevent Enemy Use.....	0001 00-3
Doffing of Hard Armor.....	0005 00-6
Donning Procedures, AIRSAVE (Type I).....	0005 00-2

ALPHABETICAL INDEX - Continued

WP Sequence Number-Page No.

E

Effective Pages, List of	A
Emergency Evacuation Procedures: Using the Safety Restraint Tether	0013 00-1
Encasement Assemblies Cleaning	0008 00-3
Equipment, Auxiliary, Operating Under Usual Conditions.....	0006 00-1
Equipment Characteristics, Capabilities, and Features.....	0002 00-1
Equipment Data	0002 00-11
Equipment Description and Data Work Package	0002 00-1
Equipment Improvement Recommendations (EIR), Reporting	0001 00-2
Errors, Reporting	i
Evacuation Procedures, Emergency	0013 00-1
Expendable and Durable Items List.....	0012 00-2
Expendable and Durable Items List Work Package	0012 00-1

F

Features, Equipment	0002 00-1
.50 Caliber Carrier Cleaning	0008 00-3
.50 Caliber Hard Body Armor Assembly: Equipment Characteristics, Capabilities, and Features ..	0002 00-2
.50 Caliber Plate Cleaning.....	0008 00-3
Forms, Maintenance	0001 00-1

ALPHABETICAL INDEX - Continued

WP Sequence Number-Page No.

G

General Information Work Package 0001 00-1

H

Hard Ballistic Inserts Cleaning 0008 00-3

Hard Body Armor Assembly:

 Doffing 0005 00-6

 Equipment Characteristics, Capabilities, and Features... 0002 00-2

 Equipment Data 0002 00-11

 Location and Description of Major Components 0002 00-8

Helicopter Emergency Egress Device (HEED):

 (See SRU-34/P)

I

Improvements, Recommending i

Inserts, Hard Ballistic, Cleaning 0008 00-3

Inserts, Soft Ballistic, Cleaning 0008 00-2

Inspections (Auxiliary Equipment) 0006 00-1

L

Life Preserver Assembly: Equipment Characteristics,

 Capabilities, and Features 0002 00-3

List of Abbreviations and Acronyms 0001 00-4

List of Effective Pages A

Location and Description of Major Components 0002 00-5

ALPHABETICAL INDEX - Continued

WP Sequence Number-Page No.

L - Continued

LPU-34/P Low-Profile Flotation Collar (LPFC):

Description and Use of Operator Controls and Indicators	0004 00-3
Equipment Characteristics, Capabilities, and Features ..	0002 00-3
Equipment Data.....	0002 00-11
Location and Description of Major Components.....	0002 00-9
Theory of Operation.....	0003 00-2

M

Maintenance:

Operator	0008 00-1
Preventive	0007 00-1
Maintenance Forms, Records, and Reports.....	0001 00-1
Major Components, Location and Description.....	0002 00-5

Modular Pockets:

Attachment	0002 00-5
Operation	0006 00-1

O

Operating Auxiliary Equipment Under Usual

Conditions Work Package	0006 00-1
Operation, Theory of	0003 00-1
Operation Under Usual Conditions Work Package.....	0005 00-1
Operator Controls and Indicators.....	0004 00-1
Operator Maintenance Work Package.....	0008 00-1
Operator Preventive Maintenance Checks and Services (PMCS).....	0007 00-3

ALPHABETICAL INDEX - Continued

WP Sequence Number-Page No.

P

Packing, Donning, and Doffing of AIRSAVE Vest and Body Armor.....	0005 00-2
Plate, .50 Caliber Hard, Cleaning	0008 00-3
PMCS, Including Lubrication Instructions Work Package.....	0007 00-1
Pockets, Modular:	
Attachment.....	0002 00-5
Operation	0006 00-1
Preparation for Storage or Shipment	0001 00-3, 0008 00-6
Preparation for Use	0005 00-1
Preventive Maintenance Checks and Services (PMCS), Operator	0007 00-3

R

Records, Maintenance.....	0001 00-1
References Work Package.....	0009 00-1
Reporting Equipment Improvement Recommendations (EIR).....	0001 00-2
Reporting Errors and Recommending Improvements.....	i
Reports, Maintenance	0001 00-1

ALPHABETICAL INDEX - Continued

WP Sequence Number-Page No.

S

Safety Restraint Tether (SRT):	
Cleaning.....	0008 00-5
Description and Use of Operator Controls and Indicators	0004 00-7
Emergency Evacuation Procedures.....	0013 00-1
Equipment Characteristics, Capabilities, and Features ..	0002 00-4
Equipment Data.....	0002 00-11
Location and Description of Major Components.....	0002 00-10
Theory of Operation.....	0003 00-3
Scope (of manual).....	0001 00-1
Soft Ballistic Inserts Cleaning	0008 00-2
Soft Body Armor Assembly:	
Equipment Characteristics, Capabilities, and Features ..	0002 00-2
Equipment Data.....	0002 00-11
Location and Description of Major Components.....	0002 00-7
SRU-36/P Helicopter Emergency Egress Device (HEED):	
Description and Use of Operator Controls and Indicators	0004 00-6
Equipment Characteristics, Capabilities, and Features ..	0002 00-4
Equipment Data.....	0002 00-11
Location and Description of Major Components.....	0002 00-10
Theory of Operation.....	0003 00-3
Storage or Shipment, Preparation for	0001 00-3
	0008 00-6

ALPHABETICAL INDEX - Continued

WP Sequence Number-Page No.

S - Continued

Survival Vest Assembly:

AIRSAVE Vest and Modular Pocket Attachment	0002 00-5
Cleaning	0008 00-1
Description and Use of Operator Controls and Indicators	0004 00-1
Equipment Characteristics, Capabilities, and Features...	0002 00-1
Equipment Data	0002 00-11
Theory of Operation	0003 00-1

T

Table of Contents	iii
Theory of Operation Work Package	0003 00-1

U

Use, Assembly and Preparation for	0005 00-1
Usual Conditions, Operation Under	0005 00-1

V

Vest, Survival (See Survival Vest Assembly)

W

Warning Summary	a
-----------------------	---

By Order of the Secretary of the Army:

ERIC K. SHINSEKI
General, United States Army
Chief of Staff

Official:



JOEL B. HUDSON
Administrative Assistant to the
Secretary of the Army
05540

Distribution:

To be distributed in accordance with Initial Distribution Number (IDN) 313810, requirements for TM 1-1680-361-10.

[

]

077677-000

L

]

This fine document...

Was brought to you by me:



[Liberated Manuals -- free army and government manuals](#)

Why do I do it? I am tired of sleazy CD-ROM sellers, who take publicly available information, slap “watermarks” and other junk on it, and sell it. Those masters of search engine manipulation make sure that their sites that sell free information, come up first in search engines. They did not create it... They did not even scan it... Why should they get your money? Why are not letting you give those free manuals to your friends?

I am setting this document FREE. This document was made by the US Government and is NOT protected by Copyright. Feel free to share, republish, sell and so on.

I am not asking you for donations, fees or handouts. If you can, please provide a link to liberatedmanuals.com, so that free manuals come up first in search engines:

<A HREF=<http://www.liberatedmanuals.com/>>Free Military and Government Manuals

– Sincerely
Igor Chudov
<http://igor.chudov.com/>