





Mr. C. H. White

Mrs. F. S. Munson

Sidora Martiney King.

Mrs L. E. Key.

Mrs. W. J. Scholl.

Miss J. Austin

Mrs B. H. Heinemann.

Mrs. Alice E. Bradwell

Mr. C. H. Waterman.

Amelia Grosser.

Mrs Fanny B. Welch.

Mrs. E. Shoualter

Miss Burgess.

Mrs E M Crippen,

Mrs F. A. Lee,

Mrs. P. D. Robinson

Blanche A. Kottmeier

Mrs J. R. Sarskup.



Digitized by the Internet Archive
in 2014

THE
STONES OF VENICE

VOLUME I—THE FOUNDATIONS

VOLUME II—THE SEA-STORIES

BY

JOHN RUSKIN, M.A.

AUTHOR OF "THE SEVEN LAMPS OF ARCHITECTURE," "THE CROWN OF WILD OLIVE,"
"SESAME AND LILIES," ETC.

BOSTON
ALDINE BOOK PUBLISHING CO.
PUBLISHERS

PREFACE.

IN the course of arranging the following essay, I put many things aside in my thoughts to be said in the Preface, things which I shall now put aside altogether, and pass by ; for when a book has been advertised a year and a half, it seems best to present it with as little preface as possible.

Thus much, however, it is necessary for the reader to know, that, when I planned the work, I had materials by me, collected at different times of sojourn in Venice during the last seventeen years, which it seemed to me might be arranged with little difficulty, and which I believe to be of value as illustrating the history of Southern Gothic. Requiring, however, some clearer assurance respecting certain points of chronology, I went to Venice finally in the autumn of 1849, not doubting but that the dates of the principal edifices of the ancient city were either ascertained, or ascertainable without extraordinary research. To my consternation, I found that the Venetian antiquaries were not agreed within a century as to the date of the building of the façades of the Ducal Palace, and that nothing was known of any other civil edifice of the early city, except that at some time or other it had been fitted up for somebody's reception, and been thereupon fresh painted. Every date in question was determinable only by internal evidence, and it became necessary for me to examine not only every one of the older palaces, stone by stone, but every fragment throughout the city which afforded any clue to the formation of its styles. This I did as well as I could, and I believe there will be found, in the following pages, the only existing account of the details of early Venetian architect-

ure on which dependence can be placed, as far as it goes. I do not care to point out the deficiencies of other works on this subject ; the reader will find, if he examines them, either that the buildings to which I shall specially direct his attention have been hitherto undescribed, or else that there are great discrepancies between previous descriptions and mine : for which discrepancies I may be permitted to give this single and sufficient reason, that my account of every building is based on personal examination and measurement of it, and that my taking the pains so to examine what I had to describe, was a subject of grave surprise to my Italian friends. The work of the Marchese Selvatico is, however, to be distinguished with respect ; it is clear in arrangement, and full of useful, though vague, information ; and I have found cause to adopt, in great measure, its views of the chronological succession of the edifices of Venice. I shall have cause hereafter to quarrel with it on other grounds, but not without expression of gratitude for the assistance it has given me. Fontana's "Fabbriche di Venezia" is also historically valuable, but does not attempt to give architectural detail. Cicognara, as is now generally known, is so inaccurate as hardly to deserve mention.

Indeed, it is not easy to be accurate in an account of anything, however simple. Zoologists often disagree in their descriptions of the curve of a shell, or the plumage of a bird, though they may lay their specimen on the table, and examine it at their leisure ; how much greater becomes the likelihood of error in the description of things which must be in many parts observed from a distance, or under unfavorable circumstances of light and shade ; and of which many of the distinctive features have been worn away by time. I believe few people have any idea of the cost of truth in these things ; of the expenditure of time necessary to make sure of the simplest facts, and of the strange way in which separate observations will sometimes falsify each other, incapable of reconciliation, owing to some imperceptible inadvertency. I am ashamed of the number of times in which I have had to say, in the following pages, "I am not sure," and I claim for them no authority, as if they were thoroughly sifted from error,

even in what they more confidently state. Only, as far as my time, and strength, and mind served me, I have endeavored, down to the smallest matters, to ascertain and speak the truth.

Nor was the subject without many and most discouraging difficulties, peculiar to itself. As far as my inquiries have extended, there is not a building in Venice, raised prior to the sixteenth century, which has not sustained essential change in one or more of its most important features. By far the greater number present examples of three or four different styles, it may be successive, it may be accidentally associated; and, in many instances, the restorations or additions have gradually replaced the entire structure of the ancient fabric, of which nothing but the name remains, together with a kind of identity, exhibited in the anomalous association of the modernized portions: the Will of the old building asserted through them all, stubbornly, though vainly, expressive; superseded by codicils, and falsified by misinterpretation; yet animating what would otherwise be a mere group of fantastic masque, as embarrassing to the antiquary, as to the mineralogist, the epigene crystal, formed by materials of one substance modelled on the perished crystals of another. The church of St. Mark's itself, harmonious as its structure may at first sight appear, is an epitome of the changes of Venetian architecture from the tenth to the nineteenth century. Its crypt, and the line of low arches which support the screen, are apparently the earliest portions; the lower stories of the main fabric are of the eleventh and twelfth centuries, with later Gothic interpolations; the pinnacles are of the earliest fully developed Venetian Gothic (fourteenth century); but one of them, that on the projection of the eastern extremity of the Piazzetta de Leoni, is of far finer, and probably earlier workmanship than all the rest. The southern range of pinnacles is again inferior to the northern and western, and visibly of later date. Then the screen, which most writers have described as part of the original fabric, bears its date inscribed on its architrave, 1394, and with it are associated a multitude of small screens, balustrades, decorations of the interior building, and probably the rose window of the south

transept. Then come the interpolated traceries of the front and sides ; then the crocketings of the upper arches, extravagances of the incipient Renaissance : and, finally, the figures which carry the water-spouts on the north side—utterly barbarous seventeenth or eighteenth century work—connect the whole with the plastered restorations of the year 1844 and 1845. Most of the palaces in Venice have sustained interpolations hardly less numerous ; and those of the Ducal Palace are so intricate, that a year's labor would probably be insufficient altogether to disentangle and define them. I therefore gave up all thoughts of obtaining a perfectly clear chronological view of the early architecture ; but the dates necessary to the main purposes of the book the reader will find well established ; and of the evidence brought forward for those of less importance, he is himself to judge. Doubtful estimates are never made grounds of argument ; and the accuracy of the account of the buildings themselves, for which alone I pledge myself, is of course entirely independent of them.

In like manner, as the statements briefly made in the chapters on construction involve questions so difficult and so general, that I cannot hope that every expression referring to them will be found free from error : and as the conclusions to which I have endeavored to lead the reader are thrown into a form the validity of which depends on that of each successive step, it might be argued, if fallacy or weakness could be detected in one of them, that all the subsequent reasonings were valueless. The reader may be assured, however, that it is not so ; the method of proof used in the following essay being only one out of many which were in my choice, adopted because it seemed to me the shortest and simplest, not as being the strongest. In many cases, the conclusions are those which men of quick feeling would arrive at instinctively ; and I then sought to discover the reasons of what so strongly recommended itself as truth. Though these reasons could every one of them, from the beginning to the end of the book, be proved insufficient, the truth of its conclusions would remain the same. I should only regret that I had dishonored

them by an ill-grounded defence ; and endeavor to repair my error by a better one.

I have not, however, written carelessly ; nor should I in any wise have expressed doubt of the security of the following argument, but that it is physically impossible for me, being engaged quite as much with mountains, and clouds, and trees, and criticism of painting, as with architecture, to verify, as I should desire, the expression of every sentence bearing upon empirical and technical matters. Life is not long enough ; nor does a day pass by without causing me to feel more bitterly the impossibility of carrying out to the extent which I should desire, the separate studies which general criticism continually forces me to undertake. I can only assure the reader, that he will find the certainty of every statement I permit myself to make, increase with its importance ; and that, for the security of the final conclusions of the following essay, as well as for the resolute veracity of its account of whatever facts have come under my own immediate cognizance, I will pledge myself to the uttermost.

It was necessary, to the accomplishment of the purpose of the work (of which account is given in the First Chapter), that I should establish some canons of judgment, which the general reader should thoroughly understand, and, if it pleased him, accept, before we took cognizance, together, of any architecture whatsoever. It has taken me more time and trouble to do this than I expected ; but, if I have succeeded, the thing done will be of use for many other purposes than that to which it is now put. The establishment of these canons, which I have called "the Foundations," and some account of the connection of Venetian architecture with that of the rest of Europe, have filled the present volume. The second will, I hope, contain all I have to say about Venice itself.

It was of course inexpedient to reduce drawings of crowded details to the size of an octavo volume,—I do not say impossible, but inexpedient ; requiring infinite pains on the part of the engraver, with no result except farther pains to the beholder. And as, on the other hand, folio books are not easy

reading, I determined to separate the text and the unreducible plates. I have given, with the principal text, all the illustrations absolutely necessary to the understanding of it, and, in the detached work, such additional text as has special reference to the larger illustrations.

A considerable number of these larger plates were at first intended to be executed in tinted lithography; but, finding the result unsatisfactory, I have determined to prepare the principal subjects for mezzotinting,—a change of method requiring two new drawings to be made of every subject; one a carefully penned outline for the etcher, and then a finished drawing upon the etching. This work does not proceed fast, while I am also occupied with the completion of the text; but the numbers of it will appear as fast as I can prepare them.

For the illustrations of the body of the work itself, I have used any kind of engraving which seemed suited to the subjects—line and mezzotint, on steel, with mixed lithographs and woodcuts, at considerable loss of uniformity in the appearance of the volume, but, I hope, with advantage, in rendering the character of the architecture it describes. And both in the plates and the text I have aimed chiefly at clear intelligibility; that any one, however little versed in the subject, might be able to take up the book, and understand what it meant forthwith. I have utterly failed of my purpose, if I have not made all the essential parts of the essay intelligible to the least learned, and easy to the most desultory readers, who are likely to take interest in the matter at all. There are few passages which even require so much as an acquaintance with the elements of Euclid, and these may be missed, without harm to the sense of the rest, by every reader to whom they may appear mysterious; and the architectural terms necessarily employed (which are very few) are explained as they occur, or in a note; so that, though I may often be found trite or tedious, I trust that I shall not be obscure. I am especially anxious to rid this essay of ambiguity, because I want to gain the ear of all kinds of persons. Every man has, at some time of his life, personal interest in archi-

ecture. He has influence on the design of some public building ; or he has to buy, or build, or alter his own house. It signifies less whether the knowledge of other arts be general or not ; men may live without buying pictures or statues : but, in architecture, all must in some way commit themselves ; they *must* do mischief, and waste their money, if they do not know how to turn it to account. Churches, and shops, and warehouses, and cottages, and small row, and place, and terrace houses, must be built, and lived in, however joyless or inconvenient. And it is assuredly intended that all of us should have knowledge, and act upon our knowledge, in matters with which we are daily concerned, and not to be left to the caprice of architects or mercy of contractors. There is not, indeed, anything in the following essay bearing on the special forms and needs of modern buildings ; but the principles it inculcates are universal ; and they are illustrated from the remains of a city which should surely be interesting to the men of London, as affording the richest existing examples of architecture raised by a mercantile community, for civil uses, and domestic magnificence.

DENMARK HILL, *February*, 1851.

CONTENTS.

	PAGE
PREFACE,	3
CHAPTER I.	
The Quarry,	15
CHAPTER II.	
The Virtues of Architecture,	48
CHAPTER III.	
The Six Divisions of Architecture,	59
CHAPTER IV.	
The Wall Base,	63
CHAPTER V.	
The Wall Veil,	68
CHAPTER VI.	
The Wall Cornice,	72
CHAPTER VII.	
The Pier Base,	80
CHAPTER VIII.	
The Shaft,	92
CHAPTER IX.	
The Capital,	112
CHAPTER X.	
The Arch Line,	128

CHAPTER XI.

The Arch Masonry, 137

CHAPTER XII.

The Arch Load, 149

CHAPTER XIII.

The Roof, 152

CHAPTER XIV.

The Roof Cornice, 158

CHAPTER XV.

The Buttress, 169

CHAPTER XVI.

Form of Aperture, 176

CHAPTER XVII.

Filling of Aperture, 185

CHAPTER XVIII.

Protection of Aperture, 196

CHAPTER XIX.

Superimposition, 200

CHAPTER XX.

The Material of Ornament, 211

CHAPTER XXI.

Treatment of Ornament, 235

CHAPTER XXII.

The Angle, 257

CHAPTER XXIII.

The Edge and Fillet, 264

CHAPTER XXIV.

The Roll and Recess, 273

CONTENTS.

13

PAGE

CHAPTER XXV.

The Base, 277

CHAPTER XXVI.

The Wall Veil and Shaft, 289

CHAPTER XXVII.

The Cornice and Capital, 299

CHAPTER XXVIII.

The Archivolt and Aperture, 326

CHAPTER XXIX.

The Roof, 335

CHAPTER XXX.

The Vestibule, 341

APPENDIX.

1. Foundation of Venice,	351
2. Power of the Doges,	352
3. Serrar del Consiglio,	352
4. S. Pietro di Castello,	353
5. Papal Power in Venice,	354
6. Renaissance Ornaments,	362
7. Varieties of the Orders,	363
8. The Northern Energy,	364
9. Wooden Churches of the North,	374
10. Church of Alexandria,	375
11. Renaissance Landscape,	375
12. Romanist Modern Art,	377
13. Mr. Fergusson's System,	382
14. Divisions of Humanity,	389

	PAGE
15. Instinctive Judgments,	394
16. Strength of Shafts,	397
17. Answer to Mr. Garbett,	398
18. Early English Capitals,	407
19. Tombs near St. Anastasia,	408
20. Shafts of Ducal Palace,	409
21. Ancient Representations of Water,	412
22. Arabian Ornamentation,	425
23. Varieties of Chamfer,	425
24. Renaissance Bases,	427
25. Romanist Decoration of Bases,	428

LIST OF ILLUSTRATIONS.

STONES OF VENICE, VOLUME ONE.

PLATE	FACING PAGE
1. Wall-veil Decoration. Ca' Trevisan, Ca' Dario,	27
2. Plans of Piers,	108
3. Arch Masonry,	139
4. Arch Masonry,	141
5. Arch Masonry. Broletto of Como,	147
6. Types of Towers,	207
7. Abstract Lines,	222
8. Decorations by Disks. Palazzo Dei Badoari Partecipazzi,	240
9. Edge Decoration,	265
10. Profile of Bases,	280
11. Plans of Bases,	283
12. Decoration of Bases,	288
13. Wall-veil Decoration,	291
14. Spandril Decoration,	294
15. Cornice Profiles,	300
16. Cornice Decoration,	305
17. Capitals. Concave Group,	317
18. Capitals. Convex,	321
19. Archivolt Decoration at Verona,	326
20. Wall-veil Decoration. Ca' Trevisan,	362
21. Wall-veil Decoration,	369

LIST OF ILLUSTRATIONS.

FIGURE	PAGE
1. Roofs,	61
2. Wall,	67
3. Lines on Walls,	72
4. Wall Cornices,	73
5. Wall Cornices,	75
6. Wall Cornices,	78
7. Wall Cornices,	78
8. Wall Cornices,	79
9. Wall Plan,	81
10. Pillars,	84
11. Pillars,	84
12. Pillars and Bases,	87
13. Shaft in Rough,	94
14. Shaft Plans,	100
15. Shaft Plans,	101
16. Shaft Plans,	102
17. Shaft Plans,	109
18. Shaft Plans,	109
19. Capitals,	113
20. Abacus,	115
21. Capitals,	116
22. Capitals Truncated,	117
23. Capitals,	118
24. Capitals,	120
25. Capitals,	121
26. Capitals,	121
27. Venetian Windows,	124
28. Part of Church Santa Fosca,	125
29. Arch Lines,	129
30. Arch Lines,	133

LIST OF ILLUSTRATIONS.

FIGURE	PAGE
31. Arch Lines,	134
32. Horseshoe Arch,	135
33. Arch Lines,	136
34. Side Arch,	148
35. Arch Loads,	149
36. Arch Front,	150
37. Gabled Roof,	154
38. Bracket,	163
39. Stone or Timber Bracket,	164
40. Brick Bracket,	165
41. Renaissance Bracket,	165
42. Southern Apse,	174
43. Aperture Plan,	178
44. Window Ovals,	183
45. Window Bars,	187
46. Window Bars,	193
47. Window Bars,	194
48. Door Protections,	197
49. Door Protections, Fiesole,	197
50. Door Protections, Plans,	198
51. Angle Plan,	258
52. Angle Mouldings, Ornamental,	260
53. Angle Mouldings, Ornamental,	261
54. Angle Mouldings, Ornamental,	262
55. Angle Mouldings, Ornamental,	263
56. Dog Tooth Edge,	268
57. Byzantine Stilted Arches,	269
58. Curved Arch Armor,	270
59. Lower Roll,	282
60. Base Roll,	283

LIST OF ILLUSTRATIONS.

FIGURE	PAGE
61. Spandril Space,	293
62. Shaft from St. Zeno,	298
63. Cornice Plans,	312
64. Cornice Plans,	314
65. Plan of Capitals,	317
66. Plan of Capitals,	322
67. Plan of Capitals,	322
68. Plan of Capitals,	323
69. Archivolt,	326
70. Archivolt Decoration. Southern and Byzantine,	329
Sea, by Greek Architect,	344
71. River, by Egyptian Artist,	415
72. Varieties of Chamfer,	426

THE STONES OF VENICE.

CHAPTER I.

THE QUARRY.

§ I. SINCE the first dominion of men was asserted over the ocean, three thrones, of mark beyond all others, have been set upon its sands: the thrones of Tyre, Venice, and England. Of the First of these great powers only the memory remains; of the Second, the ruin; the Third, which inherits their greatness, if it forget their example, may be led through prouder eminence to less pitied destruction.

The exaltation, the sin, and the punishment of Tyre have been recorded for us, in perhaps the most touching words ever uttered by the Prophets of Israel against the cities of the stranger. But we read them as a lovely song; and close our ears to the sternness of their warning: for the very depth of the Fall of Tyre has blinded us to its reality, and we forget, as we watch the bleaching of the rocks between the sunshine and the sea, that they were once "as in Eden, the garden of God."

Her successor, like her in perfection of beauty, though less in endurance of dominion, is still left for our beholding in the final period of her decline: a ghost upon the sands of the sea, so weak—so quiet,—so bereft of all but her loveliness, that we might well doubt, as we watched her faint reflection in the mirage of the lagoon, which was the City, and which the Shadow.

I would endeavor to trace the lines of this image before it be for ever lost, and to record, as far as I may, the warning which seems to me to be uttered by every one of the fast-

gaining waves, that beat, like passing bells, against the STONES OF VENICE.

§ II. It would be difficult to overrate the value of the lessons which might be derived from a faithful study of the history of this strange and mighty city : a history which, in spite of the labor of countless chroniclers, remains in vague and disputable outline,—barred with brightness and shade, like the far away edge of her own ocean, where the surf and the sand-bank are mingled with the sky. The inquiries in which we have to engage will hardly render this outline clearer, but their results will, in some degree, alter its aspect ; and, so far as they bear upon it at all, they possess an interest of a far higher kind than that usually belonging to architectural investigations. I may, perhaps, in the outset, and in few words, enable the general reader to form a clearer idea of the importance of every existing expression of Venetian character through Venetian art, and of the breadth of interest which the true history of Venice embraces, than he is likely to have gleaned from the current fables of her mystery or magnificence.

§ III. Venice is usually conceived as an oligarchy : She was so during a period less than the half of her existence, and that including the days of her decline ; and it is one of the first questions needing severe examination, whether that decline was owing in any wise to the change in the form of her government, or altogether, as assuredly in great part, to changes, in the character of the persons of whom it was composed.

The state of Venice existed Thirteen Hundred and Seventy-six years, from the first establishment of a consular government, on the island of the Rialto,* to the moment when the General-in-chief of the French army of Italy pronounced the Venetian republic a thing of the past. Of this period, Two Hundred and Seventy-six † years were passed in a nominal subjection to the cities of old Venetia, especially to Padua, and in an agitated form of democracy, of which the executive appears to have been entrusted to tribunes, ‡ chosen, one by the inlab-

* Appendix 1, "Foundation of Venice."

† Appendix 2, "Power of the Doges."

‡ Sismondi, *Hist. des Rép. Ital.*, vol. i. ch. v.

itants of each of the principal islands. For six hundred years,* during which the power of Venice was continually on the increase, her government was an elective monarchy, her King or doge possessing, in early times at least, as much independent authority as any other European sovereign, but an authority gradually subjected to limitation, and shortened almost daily of its prerogatives, while it increased in a spectral and incalculable magnificence. The final government of the nobles, under the image of a king, lasted for five hundred years, during which Venice reaped the fruits of her former energies, consumed them,—and expired.

§ iv. Let the reader therefore conceive the existence of the Venetian state as broadly divided into two periods: the first of nine hundred, the second of five hundred years, the separation being marked by what was called the “Serrar del Consiglio;” that is to say, the final and absolute distinction of the nobles from the commonalty, and the establishment of the government in their hands to the exclusion alike of the influence of the people on the one side, and the authority of the doge on the other.

Then the first period, of nine hundred years, presents us with the most interesting spectacle of a people struggling out of anarchy into order and power; and then governed, for the most part, by the worthiest and noblest man whom they could find among them,† called their Doge or Leader, with an aristocracy gradually and resolutely forming itself around him, out of which, and at last by which, he was chosen; an aristocracy owing its origin to the accidental numbers, influence, and wealth of some among the families of the fugitives from the older Venetia, and gradually organizing itself, by its unity and heroism, into a separate body.

This first period includes the rise of Venice, her noblest achievements, and the circumstances which determined her character and position among European powers; and within

* Appendix 3, “Serrar del Consiglio.”

† “Ha saputo trovar modo che non uno, non pochi, non molti, signoreggiano, ma molti buoni, pochi migliori, e insieme, *un ottimo solo.*” (*Sansovino.*) Ah, well done, Venice! Wisdom this, indeed.

its range, as might have been anticipated, we find the names of all her hero princes,—of Pietro Urseolo, Ordalafò Falier, Domenico Michieli, Sebastiano Ziani, and Enrico Dandolo.

§ v. The second period opens with a hundred and twenty years, the most eventful in the career of Venice—the central struggle of her life—stained with her darkest crime, the murder of Carrara—disturbed by her most dangerous internal sedition, the conspiracy of Falier—oppressed by her most fatal war, the war of Chiozza—and distinguished by the glory of her two noblest citizens (for in this period the heroism of her citizens replaces that of her monarchs), Vittor Pisani and Carlo Zeno.

I date the commencement of the fall of Venice from the death of Carlo Zeno, 8th May, 1418 ; * the *visible* commencement from that of another of her noblest and wisest children, the Doge Tomaso Mocenigo, who expired five years later. The reign of Foscari followed, gloomy with pestilence and war ; a war in which large acquisitions of territory were made by subtle or fortunate policy in Lombardy, and disgrace, significant as irreparable, sustained in the battles on the Po at Cremona, and in the marshes of Caravaggio. In 1454, Venice, the first of the states of Christendom, humiliated herself to the Turk : in the same year was established the Inquisition of State, † and from this period her government takes the perfidious and mysterious form under which it is usually conceived. In 1477, the great Turkish invasion spread terror to the shores of the lagoons ; and in 1508 the league of Cambrai marks the period usually assigned as the commencement of the decline of the Venetian power ; ‡ the commercial prosperity of Venice in the close of the fifteenth century blinding her historians to the previous evidence of the diminution of her internal strength.

* Daru, liv. xii. ch. xii.

† Daru, liv. xvi. cap. xx. We owe to this historian the discovery of the statutes of the tribunal and date of its establishment.

‡ Ominously signified by their humiliation to the Papal power (as before to the Turkish) in 1509, and their abandonment of their right of appointing the clergy of their territories.

§ VI. Now there is apparently a significative coincidence between the establishment of the aristocratic and oligarchical powers, and the diminution of the prosperity of the state. But this is the very question at issue; and it appears to me quite undetermined by any historian, or determined by each in accordance with his own prejudices. It is a triple question: first, whether the oligarchy established by the efforts of individual ambition was the cause, in its subsequent operation, of the Fall of Venice; or (secondly) whether the establishment of the oligarchy itself be not the sign and evidence, rather than the cause, of national enervation; or (lastly) whether, as I rather think, the history of Venice might not be written almost without reference to the construction of her senate or the prerogatives of her Doge. It is the history of a people eminently at unity in itself, descendants of Roman race, long disciplined by adversity, and compelled by its position either to live nobly or to perish:—for a thousand years they fought for life; for three hundred they invited death: their battle was rewarded, and their call was heard.

§ VII. Throughout her career, the victories of Venice, and, at many periods of it, her safety, were purchased by individual heroism; and the man who exalted or saved her was sometimes (oftenest) her king, sometimes a noble, sometimes a citizen. To him no matter, nor to her: the real question is, not so much what names they bore, or with what powers they were entrusted, as how they were trained; how they were made masters of themselves, servants of their country, patient of distress, impatient of dishonor; and what was the true reason of the change from the time when she could find saviours among those whom she had cast into prison, to that when the voices of her own children commanded her to sign covenant with Death.*

§ VIII. On this collateral question I wish the reader's mind to be fixed throughout all our subsequent inquiries. It will give double interest to every detail: nor will the interest be profitless; for the evidence which I shall be able to deduce

* The senate voted the abdication of their authority by a majority of 512 to 14. (Alison, ch. xxiii.)

from the arts of Venice will be both frequent and irrefragable, that the decline of her political prosperity was exactly coincident with that of domestic and individual religion.

I say domestic and individual ; for—and this is the second point which I wish the reader to keep in mind—the most curious phenomenon in all Venetian history is the vitality of religion in private life, and its deadness in public policy. Amidst the enthusiasm, chivalry, or fanaticism of the other states of Europe, Venice stands, from first to last, like a masked statue ; her coldness impenetrable, her exertion only aroused by the touch of a secret spring. That spring was her commercial interest,—this the one motive of all her important political acts, or enduring national animosities. She could forgive insults to her honor, but never rivalry in her commerce ; she calculated the glory of her conquests by their value, and estimated their justice by their facility. The fame of success remains, when the motives of attempt are forgotten ; and the casual reader of her history may perhaps be surprised to be reminded, that the expedition which was commanded by the noblest of her princes, and whose results added most to her military glory, was one in which while all Europe around her was wasted by the fire of its devotion, she first calculated the highest price she could exact from its piety for the armament she furnished, and then, for the advancement of her own private interests, at once broke her faith * and betrayed her religion.

§ ix. And yet, in the midst of this national criminality, we shall be struck again and again by the evidences of the most noble individual feeling. The tears of Dandolo were not shed in hypocrisy, though they could not blind him to the importance of the conquest of Zara. The habit of assigning to religion a direct influence over all *his own* actions, and all the affairs of *his own* daily life, is remarkable in every great Venetian during the times of the prosperity of the state ; nor are instances wanting in which the private feeling of the citizens

* By directing the arms of the Crusaders against a Christian prince. (Daru, liv. iv. ch. iv. viii.)

reaches the sphere of their policy, and even becomes the guide of its course where the scales of expediency are doubtfully balanced. I sincerely trust that the inquirer would be disappointed who should endeavor to trace any more immediate reasons for their adoption of the cause of Alexander III. against Barbarossa, than the piety which was excited by the character of their suppliant, and the noble pride which was provoked by the insolence of the emperor. But the heart of Venice is shown only in her hastiest councils; her worldly spirit recovers the ascendancy whenever she has time to calculate the probabilities of advantage, or when they are sufficiently distinct to need no calculation; and the entire subjection of private piety to national policy is not only remarkable throughout the almost endless series of treacheries and tyrannies by which her empire was enlarged and maintained, but symbolised by a very singular circumstance in the building of the city itself. I am aware of no other city of Europe in which its cathedral was not the principal feature. But the principal church in Venice was the chapel attached to the palace of her prince, and called the "Chiesa Ducale." The patriarchal church,* inconsiderable in size and mean in decoration, stands on the outermost islet of the Venetian group, and its name, as well as its site, is probably unknown to the greater number of travellers passing hastily through the city. Nor is it less worthy of remark, that the two most important temples of Venice, next to the ducal chapel, owe their size and magnificence, not to national effort, but to the energy of the Franciscan and Dominican monks, supported by the vast organization of those great societies on the mainland of Italy, and countenanced by the most pious, and perhaps also, in his generation, the most wise, of all the princes of Venice,† who now rests beneath the roof of one of those very temples, and whose life is not satirized by the images of the Virtues which a Tuscan sculptor has placed around his tomb.

§ x. There are, therefore, two strange and sole lights

* Appendix 4, "San Pietro di Castello."

† Tomasc Mocenigo, above named, § v.

in which we have to regard almost every scene in the fitful history of the Rivo Alto. We find, on the one hand, a deep and constant tone of individual religion characterising the lives of the citizens of Venice in her greatness; we find this spirit influencing them in all the familiar and immediate concerns of life, giving a peculiar dignity to the conduct even of their commercial transactions, and confessed by them with a simplicity of faith that may well put to shame the hesitation with which a man of the world at present admits (even if it be so in reality) that religious feeling has any influence over the minor branches of his conduct. And we find as the natural consequence of all this, a healthy serenity of mind and energy of will expressed in all their actions, and a habit of heroism which never fails them, even when the immediate motive of action ceases to be praiseworthy. With the fulness of this spirit the prosperity of the state is exactly correspondent, and with its failure her decline, and that with a closeness and precision which it will be one of the collateral objects of the following essay to demonstrate from such accidental evidence as the field of its inquiry presents. And, thus far, all is natural and simple. But the stopping short of this religious faith when it appears likely to influence national action, correspondent as it is, and that most strikingly, with several characteristics of the temper of our present English legislature, is a subject, morally and politically, of the most curious interest and complicated difficulty; one, however, which the range of my present inquiry will not permit me to approach, and for the treatment of which I must be content to furnish materials in the light I may be able to throw upon the private tendencies of the Venetian character.

§ XI. There is, however, another most interesting feature in the policy of Venice which will be often brought before us; and which a Romanist would gladly assign as the reason of its irreligion; namely, the magnificent and successful struggle which she maintained against the temporal authority of the Church of Rome. It is true that, in a rapid survey of her career, the eye is at first arrested by the strange drama to which I have already alluded, closed by that ever memorable

scene in the portico of St Mark's,* the central expression in most men's thoughts of the unendurable elevation of the pontifical power ; it is true that the proudest thoughts of Venice, as well as the insignia of her prince, and the form of her chief festival, recorded the service thus rendered to the Roman Church. But the enduring sentiment of years more than balanced the enthusiasm of a moment ; and the bull of Clement V., which excommunicated the Venetians and their doge, likening them to Dathan, Abiram, Absalom, and Lucifer, is a stronger evidence of the great tendencies of the Venetian government than the umbrella of the doge or the ring of the Adriatic. The humiliation of Francesco Dandolo blotted out the shame of Barbarossa, and the total exclusion of ecclesiastics from all share in the councils of Venice became an enduring mark of her knowledge of the spirit of the Church of Rome, and of her defiance of it.

To this exclusion of Papal influence from her councils, the Romanist will attribute their irreligion, and the Protestant their success.† The first may be silenced by a reference to the character of the policy of the Vatican itself ; and the second by his own shame, when he reflects that the English legislature sacrificed their principles to expose themselves to the very danger which the Venetian senate sacrificed theirs to avoid.

§ XII. One more circumstance remains to be noted respecting the Venetian government, the singular unity of the families composing it,—unity far from sincere or perfect, but still

* “ In that temple porch,

(The brass is gone, the porphyry remains,)

Did BARBAROSSA fling his mantle off,

And kneeling, on his neck receive the foot

Of the proud Pontiff—thus at last consoled

For flight, disguise, and many an aguish shake

On his stone pillow.”

I need hardly say whence the lines are taken : Rogers' “ Italy ” has, I believe, now a place in the best beloved compartment of all libraries, and will never be removed from it. There is more true expression of the spirit of Venice in the passages devoted to her in that poem, than in all else that has been written of her.

† At least, such success as they had. Vide Appendix 5, “ The Papal Power in Venice.”

admirable when contrasted with the fiery feuds, the almost daily revolutions, the restless successions of families and parties in power, which fill the annals of the other states of Italy. That rivalry should sometimes be ended by the dagger, or enmity conducted to its ends under the mask of law, could not but be anticipated where the fierce Italian spirit was subjected to so severe a restraint: it is much that jealousy appears usually unmingled with illegitimate ambition, and that, for every instance in which private passion sought its gratification through public danger, there are a thousand in which it was sacrificed to the public advantage. Venice may well call upon us to note with reverence, that of all the towers which are still seen rising like a branchless forest from her islands, there is but one whose office was other than that of summoning to prayer, and that one was a watch-tower only: from first to last, while the palaces of the other cities of Italy were lifted into sullen fortitudes of rampart, and fringed with forked battlements for the javelin and the bow, the sands of Venice never sank under the weight of a war tower, and her roof terraces were wreathed with Arabian imagery, of golden globes suspended on the leaves of lilies.*

§ XIII. These, then, appear to me to be the points of chief general interest in the character and fate of the Venetian people. I would next endeavor to give the reader some idea of the manner in which the testimony of Art bears upon these questions, and of the aspect which the arts themselves assume when they are regarded in their true connexion with the history of the state.

1st. Receive the witness of Painting.

It will be remembered that I put the commencement of the Fall of Venice as far back as 1418.

Now, John Bellini was born in 1423, and Titian in 1480. John Bellini, and his brother Gentile, two years older than he, close the line of the sacred painters of Venice. But the most solemn spirit of religious faith animates their works to the

* The inconsiderable fortifications of the arsenal are no exception to this statement, as far as it regards the city itself. They are little more than a semblance of precaution against the attack of a foreign enemy.

last. There is no religion in any work of Titian's : there is not even the smallest evidence of religious temper or sympathies either in himself, or in those for whom he painted. His larger sacred subjects are merely themes for the exhibition of pictorial rhetoric,—composition and color. His minor works are generally made subordinate to purposes of portraiture. The Madonna in the church of the Frari is a mere lay figure, introduced to form a link of connexion between the portraits of various members of the Pesaro family who surround her.

Now this is not merely because John Bellini was a religious man and Titian was not. Titian and Bellini are each true representatives of the school of painters contemporary with them ; and the difference in their artistic feeling is a consequence not so much of difference in their own natural characters as in their early education : Bellini was brought up in faith ; Titian in formalism. Between the years of their births the vital religion of Venice had expired.

§ xiv. The *vital* religion, observe, not the formal. Outward observance was as strict as ever ; and doge and senator still were painted, in almost every important instance, kneeling before the Madonna or St. Mark ; a confession of faith made universal by the pure gold of the Venetian sequin. But observe the great picture of Titian's in the ducal palace, of the Doge Antonio Grimani kneeling before Faith : there is a curious lesson in it. The figure of Faith is a coarse portrait of one of Titian's least graceful female models : Faith had become carnal. The eye is first caught by the flash of the Doge's armor. The heart of Venice was in her wars, not in her worship.

The mind of Tintoret, incomparably more deep and serious than that of Titian, casts the solemnity of its own tone over the sacred subjects which it approaches, and sometimes forgets itself into devotion ; but the principle of treatment is altogether the same as Titian's : absolute subordination of the religious subject to purposes of decoration or portraiture.

The evidence might be accumulated a thousandfold from the works of Veronese, and of every succeeding painter,—that

the fifteenth century had taken away the religious heart of Venice.

§ xv. Such is the evidence of Painting. To collect that of Architecture will be our task through many a page to come ; but I must here give a general idea of its heads.

Philippe de Comynes, writing of his entry into Venice in 1495, says,—

“ Chascun me fait seoir au meillieu de ces deux ambassadeurs qui est l'honneur d'Italie que d'estre au meillieu ; et me menerent au long de la grant rue, qu'ilz appellent le Canal Grant, et est bien large. Les gallees y passent à travers et y ay veu navire de quatre cens tonneaux ou plus pres des maisons : et est la plus belle rue que je croy qui soit en tout le monde, et la mieulx maisonnee, et va le long de la ville. Les maisons sont fort grandes et haultes, et de bonne pierre, et les anciennes toutes painctes ; les aultres faictes depuis cent ans : toutes ont le devant de marbre blanc, qui leur vient d'Istrie, à cent mils de là, et encores maincte grant piece de porphire et de sarpentine sur le devant. . . . C'est la plus triumpante cité que j'aye jamais veue et qui plus faict d'honneur à ambassadeurs et estrangiers, et qui plus saigement se gouverne, et où le service de Dieu est le plus sollempnellement faict : et encores qu'il y peust bien avoir d'aultres faultes, si je croy que Dieu les a en ayde pour la reverence qu'ilz portent au service de l'Eglise.” *

§ xvi. This passage is of peculiar interest, for two reasons. Observe, first, the impression of Comynes respecting the religion of Venice : of which, as I have above said, the forms still remained with some glimmering of life in them, and were the evidence of what the real life had been in former times. But observe, secondly, the impression instantly made on Comynes' mind by the distinction between the elder palaces and those built “ within this last hundred years ; which all have their fronts of white marble brought from Istria, a hundred miles away, and besides, many a large piece of porphyry and serpentine upon their fronts.”

On the opposite page I have given two of the ornaments of

* Mémoires de Comynes, liv. vii. ch. xviii.



I. Ruskin.

T.S. Boys.

Wall-Veil - Decoration.

CA'TREVISAN CA'DARIO.

the palaces which so struck the French ambassador.* He was right in his notice of the distinction. There had indeed come a change over Venetian architecture in the fifteenth century; and a change of some importance to us moderns: we English owe to it our St. Paul's Cathedral, and Europe in general owes to it the utter degradation or destruction of her schools of architecture, never since revived. But that the reader may understand this, it is necessary that he should have some general idea of the connexion of the architecture of Venice with that of the rest of Europe, from its origin forwards.

§ XVII. All European architecture, bad and good, old and new, is derived from Greece through Rome, and colored and perfected from the East. The history of architecture is nothing but the tracing of the various modes and directions of this derivation. Understand this, once for all: if you hold fast this great connecting clue, you may string all the types of successive architectural invention upon it like so many beads. The Doric and the Corinthian orders are the roots, the one of all Romanesque, massy-capitaled buildings—Norman, Lombard, Byzantine, and what else you can name of the kind; and the Corinthian of all Gothic, Early English, French, German, and Tuscan. Now observe: those old Greeks gave the shaft; Rome gave the arch; the Arabs pointed and foliated the arch. The shaft and arch, the frame-work and strength of architecture, are from the race of Japheth; the spirituality and sanctity of it from Ismael, Abraham, and Shem.

§ XVIII. There is high probability that the Greek received his shaft system from Egypt; but I do not care to keep this earlier derivation in the mind of the reader. It is only necessary that he should be able to refer to a fixed point of origin, when the form of the shaft was first perfected. But it may be incidentally observed, that if the Greeks did indeed receive their Doric from Egypt, then the three families of the earth have each contributed their part to its noblest architecture: and Ham, the servant of the others, furnishes the sustaining

* Appendix 6, "Renaissance Ornaments."

or bearing member, the shaft ; Japheth the arch ; Shem the spiritualisation of both.

§ xix. I have said that the two orders, Doric and Corinthian, are the roots of all European architecture. You have, perhaps, heard of five orders ; but there are only two real orders, and there never can be any more until doomsday. On one of these orders the ornament is convex : those are Doric, Norman, and what else you recollect of the kind. On the other the ornament is concave : those are Corinthian, Early English, Decorated, and what else you recollect of that kind. The transitional form, in which the ornamental line is straight, is the centre or root of both. All other orders are varieties of those, or phantasms and grotesques altogether indefinite in number and species.*

§ xx. This Greek architecture, then, with its two orders, was clumsily copied and varied by the Romans with no particular result, until they begun to bring the arch into extensive practical service ; except only that the Doric capital was spoiled in endeavors to mend it, and the Corinthian much varied and enriched with fanciful, and often very beautiful imagery. And in this state of things came Christianity : seized upon the arch as her own ; decorated it, and delighted in it ; invented a new Doric capital to replace the spoiled Roman one : and all over the Roman empire set to work, with such materials as were nearest at hand, to express and adorn herself as best she could. This Roman Christian architecture is the exact expression of the Christianity of the time, very fervid and beautiful—but very imperfect ; in many respects ignorant, and yet radiant with a strong, childlike light of imagination, which flames up under Constantine, illumines all the shores of the Bosphorus and the Ægean and the Adriatic Sea, and then gradually, as the people give themselves up to idolatry, becomes Corpse-light. The architecture sinks into a settled form—a strange, gilded, and embalmed repose : it, with the religion it expressed ; and so would have remained for ever,—so *does* remain, where its

* Appendix 7, "Varieties of the Orders."

languor has been undisturbed.* But rough wakening was ordained for it.

§ XXI. This Christian art of the declining empire is divided into two great branches, western and eastern ; one centred at Rome, the other at Byzantium, of which the one is the early Christian Romanesque, properly so called, and the other, carried to higher imaginative perfection by Greek workmen, is distinguished from it as Byzantine. But I wish the reader, for the present, to class these two branches of art together in his mind, they being, in points of main importance, the same ; that is to say, both of them a true continuance and sequence of the art of old Rome itself, flowing uninterruptedly down from the fountain-head, and entrusted always to the best workmen who could be found—Latins in Italy and Greeks in Greece ; and thus both branches may be ranged under the general term of Christian Romanesque, an architecture which had lost the refinement of Pagan art in the degradation of the empire, but which was elevated by Christianity to higher aims, and by the fancy of the Greek workmen endowed with brighter forms. And this art the reader may conceive as extending in its various branches over all the central provinces of the empire, taking aspects more or less refined, according to its proximity to the seats of government ; dependent for all its power on the vigor and freshness of the religion which animated it ; and as that vigor and purity departed, losing its own vitality, and sinking into nerveless rest, not deprived of its beauty, but benumbed and incapable of advance or change.

§ XXII. Meantime there had been preparation for its renewal. While in Rome and Constantinople, and in the districts under their immediate influence, this Roman art of pure descent was practised in all its refinement, an impure form of it—a patois of Romanesque—was carried by inferior workmen into distant provinces ; and still ruder imitations of this patois were executed by the barbarous nations on the

* The reader will find the *weak* points of Byzantine architecture shrewdly seized, and exquisitely sketched, in the opening chapter of the most delightful book of travels I ever opened,—Curzon's "Monasteries of the Levant."

skirts of the empire. But these barbarous nations were in the strength of their youth; and while, in the centre of Europe, a refined and purely descended art was sinking into graceful formalism, on its confines a barbarous and borrowed art was organising itself into strength and consistency. The reader must therefore consider the history of the work of the period as broadly divided into two great heads: the one embracing the elaborately languid succession of the Christian art of Rome; and the other, the imitations of it executed by nations in every conceivable phase of early organisation, on the edges of the empire, or included in its now merely nominal extent.

§ xxiii. Some of the barbaric nations were, of course, not susceptible of this influence; and when they burst over the Alps, appear, like the Huns, as scourges only, or mix, as the Ostrogoths, with the enervated Italians, and give physical strength to the mass with which they mingle, without materially affecting its intellectual character. But others, both south and north of the empire, had felt its influence, back to the beach of the Indian Ocean on the one hand, and to the ice creeks of the North Sea on the other. On the north and west the influence was of the Latins; on the south and east, of the Greeks. Two nations, pre-eminent above all the rest, represent to us the force of derived mind on either side. As the central power is eclipsed, the orbs of reflected light gather into their fulness; and when sensuality and idolatry had done their work, and the religion of the empire was laid asleep in a glittering sepulchre, the living light rose upon both horizons, and the fierce swords of the Lombard and Arab were shaken over its golden paralysis.

§ xxiv. The work of the Lombard was to give hardihood and system to the enervated body and enfeebled mind of Christendom; that of the Arab was to punish idolatry, and to proclaim the spirituality of worship. The Lombard covered every church which he built with the sculptured representations of bodily exercises—hunting and war.* The Arab banished all imagination of creature form from his temples, and

* Appendix 8, "The Northern Energy."

proclaimed from their minarets, "There is no god but God." Opposite in their character and mission, alike in their magnificence of energy, they came from the North and from the South, the glacier torrent and the lava stream : they met and contended over the wreck of the Roman empire ; and the very centre of the struggle, the point of pause of both, the dead water of the opposite eddies, charged with embayed fragments of the Roman wreck, is VENICE.

The Ducal palace of Venice contains the three elements in exactly equal proportions—the Roman, Lombard, and Arab. It is the central building of the world.

§ xxv. The reader will now begin to understand something of the importance of the study of the edifices of a city which includes, within the circuit of some seven or eight miles, the field of contest between the three pre-eminent architectures of the world :—each architecture expressing a condition of religion ; each an erroneous condition, yet necessary to the correction of the others, and corrected by them.

§ xxvi. It will be part of my endeavor, in the following work, to mark the various modes in which the northern and southern architectures were developed from the Roman : here I must pause only to name the distinguishing characteristics of the great families. The Christian Roman and Byzantine work is round-arched, with single and well-proportioned shafts ; capitals imitated from classical Roman ; mouldings more or less so ; and large surfaces of walls entirely covered with imagery, mosaic, and paintings, whether of scripture history or of sacred symbols.

The Arab school is at first the same in its principal features, the Byzantine workmen being employed by the caliphs ; but the Arab rapidly introduces characters half Persepolitan, half Egyptian, into the shafts and capitals : in his intense love of excitement he points the arch and writhes it into extravagant foliations ; he banishes the animal imagery, and invents an ornamentation of his own (called Arabesque) to replace it : this not being adapted for covering large surfaces, he concentrates it on features of interest, and bars his surfaces with horizontal lines of color, the expression of the level of the

Desert. He retains the dome, and adds the minaret. All is done with exquisite refinement.

§ XXVII. The changes effected by the Lombard are more curious still, for they are in the anatomy of the building, more than its decoration. The Lombard architecture represents, as I said, the whole of that of the northern barbaric nations. And this I believe was, at first, an imitation in wood of the Christian Roman churches or basilicas. Without staying to examine the whole structure of a basilica, the reader will easily understand thus much of it: that it had a nave and two aisles, the nave much higher than the aisles; that the nave was separated from the aisles by rows of shafts, which supported, above, large spaces of flat or dead wall, rising above the aisles, and forming the upper part of the nave, now called the clerestory, which had a gabled wooden roof.

These high dead walls were, in Roman work, built of stone; but in the wooden work of the North, they must necessarily have been made of horizontal boards or timbers attached to uprights on the top of the nave pillars, which were themselves also of wood.* Now, these uprights were necessarily thicker than the rest of the timbers, and formed vertical square pilasters above the nave piers. As Christianity extended and civilisation increased, these wooden structures were changed into stone; but they were literally petrified, retaining the form which had been made necessary by their being of wood. The upright pilaster above the nave pier remains in the stone edifice, and is the first form of the great distinctive feature of Northern architecture—the vaulting shaft. In that form the Lombards brought it into Italy, in the seventh century, and it remains to this day in St. Ambrogio of Milan, and St. Michele of Pavia.

§ XXVIII. When the vaulting shaft was introduced in the clerestory walls, additional members were added for its support to the nave piers. Perhaps two or three pine trunks, used for a single pillar, gave the first idea of the grouped shaft. Be that as it may, the arrangement of the nave pier in the form of a cross accompanies the superimposition of

* Appendix 9, "Wooden Churches of the North."

the vaulting shaft ; together with corresponding grouping of minor shafts in doorways and apertures of windows. Thus, the whole body of the Northern architecture, represented by that of the Lombards, may be described as rough but majestic work, round-arched, with grouped shafts, added vaulting shafts, and endless imagery of active life and fantastic superstitions.

§ xxix. The glacier stream of the Lombards, and the following one of the Normans, left their erratic blocks, wherever they had flowed ; but without influencing, I think, the Southern nations beyond the sphere of their own presence. But the lava stream of the Arab, even after it ceased to flow, warmed the whole of the Northern air ; and the history of Gothic architecture is the history of the refinement and spiritualisation of Northern work under its influence. The noblest buildings of the world, the Pisan-Romanesque, Tuscan (Giottesque) Gothic, and Veronese Gothic, are those of the Lombard schools themselves, under its close and direct influence ; the various Gothics of the North are the original forms of the architecture which the Lombards brought into Italy, changing under the less direct influence of the Arab.

§ xxx. Understanding thus much of the formation of the great European styles, we shall have no difficulty in tracing the succession of architectures in Venice herself. From what I said of the central character of Venetian art, the reader is not, of course, to conclude that the Roman, Northern, and Arabian elements met together and contended for the mastery at the same period. The earliest element was the pure Christian Roman ; but few, if any, remains of this art exist at Venice ; for the present city was in the earliest times only one of many settlements formed on the chain of marshy islands which extend from the mouths of the Isonzo to those of the Adige, and it was not until the beginning of the ninth century that it became the seat of government ; while the cathedral of Torcello, though Christian Roman in general form, was rebuilt in the eleventh century, and shows evidence of Byzantine workmanship in many of its details. This cathedral, however, with the church of Santa Fosca at Torcello,

San Giacomo di Rialto at Venice, and the crypt of St. Mark's, forms a distinct group of buildings, in which the Byzantine influence is exceedingly slight; and which is probably very sufficiently representative of the earliest architecture on the islands.

§ xxxi. The Ducal residence was removed to Venice in 809, and the body of St. Mark was brought from Alexandria twenty years later. The first church of St. Mark's was, doubtless, built in imitation of that destroyed at Alexandria, and from which the relics of the saint had been obtained. During the ninth, tenth, and eleventh centuries, the architecture of Venice seems to have been formed on the same model, and is almost identical with that of Cairo under the caliphs,* it being quite immaterial whether the reader chooses to call both Byzantine or both Arabic; the workmen being certainly Byzantine, but forced to the invention of new forms by their Arabian masters, and bringing these forms into use in whatever other parts of the world they were employed.

To this first manner of Venetian architecture, together with such vestiges as remain of the Christian Roman, I shall devote the first division of the following inquiry. The examples remaining of it consist of three noble churches (those of Torcello, Murano, and the greater part of St. Mark's), and about ten or twelve fragments of palaces.

§ xxxii. To this stylè succeeds a transitional one, of a character much more distinctly Arabian: the shafts become more slender, and the arches consistently pointed, instead of round; certain other changes, not to be enumerated in a sentence, taking place in the capitals and mouldings. This style is almost exclusively secular. It was natural for the Venetians to imitate the beautiful details of the Arabian dwelling-house, while they would with reluctance adopt those of the mosque for Christian churches.

I have not succeeded in fixing limiting dates for this style. It appears in part contemporary with the Byzantine manner, but outlives it. Its position is, however, fixed by the central date, 1180, that of the elevation of the granite shafts of the

* Appendix 10, "Church of Alexandria."

Piazzetta, whose capitals are the two most important pieces of detail in this transitional style in Venice. Examples of its application to domestic buildings exist in almost every street of the city, and will form the subject of the second division of the following essay.

§ xxxiii. The Venetians were always ready to receive lessons in art from their enemies (else had there been no Arab work in Venice). But their especial dread and hatred of the Lombards appears to have long prevented them from receiving the influence of the art which that people had introduced on the mainland of Italy. Nevertheless, during the practice of the two styles above distinguished, a peculiar and very primitive condition of pointed Gothic had arisen in ecclesiastical architecture. It appears to be a feeble reflection of the Lombard-Arab forms, which were attaining perfection upon the continent, and would probably, if left to itself, have been soon merged in the Venetian-Arab school, with which it had from the first so close a fellowship, that it will be found difficult to distinguish the Arabian ogives from those which seem to have been built under this early Gothic influence. The churches of San Giacopo dell' Orio, San Giovanni in Bragora, the Carmine, and one or two more, furnish the only important examples of it. But, in the thirteenth century, the Franciscans and Dominicans introduced from the continent their morality and their architecture, already a distinct Gothic, curiously developed from Lombardic and Northern (German?) forms; and the influence of the principles exhibited in the vast churches of St. Paul and the Frari began rapidly to affect the Venetian-Arab school. Still the two systems never became united; the Venetian policy repressed the power of the church, and the Venetian artists resisted its example; and thenceforward the architecture of the city becomes divided into ecclesiastical and civil: the one an ungraceful yet powerful form of the Western Gothic, common to the whole peninsula, and only showing Venetian sympathies in the adoption of certain characteristic mouldings; the other a rich, luxuriant, and entirely original Gothic, formed from the Venetian-Arab by the influence of the Dominican and Franciscan architect-

ure, and especially by the engrafting upon the Arab forms of the most novel feature of the Franciscan work, its traceries. These various forms of Gothic, the *distinctive* architecture of Venice, chiefly represented by the churches of St. John and Paul, the Frari, and San Stefano, on the ecclesiastical side, and by the Ducal palace, and the other principal Gothic palaces, on the secular side, will be the subject of the third division of the essay.

§ xxxiv. Now observe. The transitional (or especially Arabic) style of the Venetian work is centralised by the date 1180, and is transformed gradually into the Gothic, which extends in its purity from the middle of the thirteenth to the beginning of the fifteenth century ; that is to say, over the precise period which I have described as the central epoch of the life of Venice. I dated her decline from the year 1418 ; Foscari became doge five years later, and in his reign the first marked signs appear in architecture of that mighty change which Philippe de Commynes notices as above, the change to which London owes St. Paul's, Rome St. Peter's, Venice and Vicenza the edifices commonly supposed to be their noblest, and Europe in general the degradation of every art she has since practised.

§ xxxv. This change appears first in a loss of truth and vitality in existing architecture all over the world. (Compare "Seven Lamps," chap. ii.). All the Gothics in existence, southern or northern, were corrupted at once : the German and French lost themselves in every species of extravagance ; the English Gothic was confined, in its insanity, by a strait-waistcoat of perpendicular lines ; the Italian effloresced on the mainland into the meaningless ornamentation of the Certosa of Pavia and the Cathedral of Como (a style sometimes ignorantly called Italian Gothic), and at Venice into the insipid confusion of the Porta della Carta and wild crockets of St. Mark's. This corruption of all architecture, especially ecclesiastical, corresponded with, and marked the state of religion over all Europe,—the peculiar degradation of the Romanist superstition, and of public morality in consequence, which brought about the Reformation.

§ XXXVI. Against the corrupted papacy arose two great divisions of adversaries, Protestants in Germany and England, Rationalists in France and Italy; the one requiring the purification of religion, the other its destruction. The Protestant kept the religion, but cast aside the heresies of Rome, and with them her arts, by which last rejection he injured his own character, cramped his intellect in refusing to it one of its noblest exercises, and materially diminished his influence. It may be a serious question how far the Pausing of the Reformation has been a consequence of this error.

The Rationalist kept the arts and cast aside the religion. This rationalistic art is the art commonly called Renaissance, marked by a return to pagan systems, not to adopt them and hallow them for Christianity, but to rank itself under them as an imitator and pupil. In Painting it is headed by Giulio Romano and Nicolo Poussin; in Architecture by Sansovino and Palladio.

§ XXXVII. Instant degradation followed in every direction,—a flood of folly and hypocrisy. Mythologies ill understood at first, then perverted into feeble sensualities, take the place of the representations of Christian subjects, which had become blasphemous under the treatment of men like the Caracci. Gods without power, satyrs without rusticity, nymphs without innocence, men without humanity, gather into idiot groups upon the polluted canvas, and scenic affectations encumber the streets with preposterous marble. Lower and lower declines the level of abused intellect; the base school of landscape* gradually usurps the place of the historical painting, which had sunk into prurient pedantry,—the Alsatian sublimities of Salvator, the confectionery idealities of Claude, the dull manufacture of Gaspar and Canaletto, south of the Alps, and on the north the patient devotion of besotted lives to delineation of bricks and fogs, fat cattle and ditch-water. And thus Christianity and morality, courage, and intellect, and art all crumbling together into one wreck, we are hurried on to the fall of Italy, the revolution in France,

* Appendix 11, "Renaissance Landscape."

and the condition of art in England (saved by her Protestantism from severer penalty) in the time of George II.

§ XXXVIII. I have not written in vain if I have heretofore done anything towards diminishing the reputation of the Renaissance landscape painting. But the harm which has been done by Claude and the Poussins is as nothing when compared to the mischief effected by Palladio, Scamozzi, and Sansovino. Claude and the Poussins were weak men, and have had no serious influence on the general mind. There is little harm in their works being purchased at high prices: their real influence is very slight, and they may be left without grave indignation to their poor mission of furnishing drawing-rooms and assisting stranded conversation. Not so the Renaissance architecture. Raised at once into all the magnificence of which it was capable by Michael Angelo, then taken up by men of real intellect and imagination, such as Scamozzi, Sansovino, Inigo Jones, and Wren, it is impossible to estimate the extent of its influence on the European mind; and that the more, because few persons are concerned with painting, and, of those few, the larger number regard it with slight attention; but all men are concerned with architecture, and have at some time of their lives serious business with it. It does not much matter that an individual loses two or three hundred pounds in buying a bad picture, but it is to be regretted that a nation should lose two or three hundred thousand in raising a ridiculous building. Nor is it merely wasted wealth or distempered conception which we have to regret in this Renaissance architecture: but we shall find in it partly the root, partly the expression, of certain dominant evils of modern times—over-sophistication and ignorant classicalism; the one destroying the healthfulness of general society, the other rendering our schools and universities useless to a large number of the men who pass through them.

Now Venice, as she was once the most religious, was in her fall the most corrupt, of European states; and as she was in her strength the centre of the pure currents of Christian architecture, so she is in her decline the source of the Renaissance. It was the originality and splendor of the Palaces of Vicenza

and Venice which gave this school its eminence in the eyes of Europe ; and the dying city, magnificent in her dissipation, and graceful in her follies, obtained wider worship in her decrepitude than in her youth, and sank from the midst of her admirers into the grave.

§ xxxix. It is in Venice, therefore, and in Venice only that effectual blows can be struck at this pestilent art of the Renaissance. Destroy its claims to admiration there, and it can assert them nowhere else. This, therefore, will be the final purpose of the following essay. I shall not devote a fourth section to Palladio, nor weary the reader with successive chapters of virtuperation ; but I shall, in my account of the earlier architecture, compare the forms of all its leading features with those into which they were corrupted by the Classicalists ; and pause, in the close, on the edge of the precipice of decline, so soon as I have made its depths discernible. In doing this I shall depend upon two distinct kinds of evidence :—the first, the testimony borne by particular incidents and facts to a want of thought or of feeling in the builders ; from which we may conclude that their architecture must be bad :—the second, the sense, which I doubt not I shall be able to excite in the reader, of a systematic ugliness in the architecture itself. Of the first kind of testimony I shall here give two instances, which may be immediately useful in fixing in the reader's mind the epoch above indicated for the commencement of decline.

§ xl. I must again refer to the importance which I have above attached to the death of Carlo Zeno and the doge Tomaso Mocenigo. The tomb of that doge is, as I said, wrought by a Florentine ; but it is of the same general type and feeling as all the Venetian tombs of the period, and it is one of the last which retains it. The classical element enters largely into its details, but the feeling of the whole is as yet unaffected. Like all the lovely tombs of Venice and Verona, it is a sarcophagus with a recumbent figure above, and this figure is a faithful but tender portrait, wrought as far as it can be without painfulness, of the doge as he lay in death. He wears his ducal robe and bonnet—his head is laid slightly aside upon his pillow—his hands are simply crossed as they fall. The

face is emaciated, the features large, but so pure and lordly in their natural chiselling, that they must have looked like marble even in their animation. They are deeply worn away by thought and death; the veins on the temples branched and starting; the skin gathered in sharp folds; the brow high-arched and shaggy; the eye-ball magnificently large; the curve of the lips just veiled by the light mustache at the side; the beard short, double, and sharp-pointed: all noble and quiet; the white sepulchral dust marking like light the stern angles of the cheek and brow.

This tomb was sculptured in 1424, and is thus described by one of the most intelligent of the recent writers who represent the popular feeling respecting Venetian art.

“Of the Italian school is also the rich but ugly (*ricco ma non bel*) sarcophagus in which repose the ashes of Tomaso Mocenigo. It may be called one of the last links which connect the declining art of the Middle Ages with that of the Renaissance, which was in its rise. We will not stay to particularise the defects of each of the seven figures of the front and sides, which represent the cardinal and theological virtues; nor will we make any remarks upon those which stand in the niches above the pavilion, because we consider them unworthy both of the age and reputation of the Florentine school, which was then with reason considered the most notable in Italy.”*

It is well, indeed, not to pause over these defects; but it might have been better to have paused a moment beside that noble image of a king's mortality.

§ XLI. In the choir of the same church, St. Giov. and Paolo, is another tomb, that of the Doge Andrea Vendramin. This doge died in 1478, after a short reign of two years, the most disastrous in the annals of Venice. He died of a pestilence which followed the ravage of the Turks, carried to the shores of the lagoons. He died, leaving Venice disgraced by sea and land, with the smoke of hostile devastation rising in the blue distances of Friuli; and there was raised to him the most costly tomb ever bestowed on her monarchs.

§ XLII. If the writer above quoted was cold beside the

* Selvatico, “Architettura di Venezia,” p. 147.

statue of one of the fathers of his country, he atones for it by his eloquence beside the tomb of the Vendramin. I must not spoil the force of Italian superlative by translation.

“Quando si guarda a quella corretta eleganza di profili e di proporzioni, a quella squisitezza d'ornamenti, a quel certo sapore antico che senza ombra d'imitazione traspare da tutta l'opera”—&c. “Sopra ornatissimo zoccolo fornito di squisiti intagli s' alza uno stylobate”—&c. “Sotto le colonne, il predetto stilobate si muta leggiadramente in piedistallo, poi con bella novità di pensiero e di effetto va coronato da un fregio il più gentile che veder si possa”—&c. “Non puossi lasciar senza un cenno l' *arca dove* sta chiuso il doge ; capo lavoro di pensiero e di esecuzione,” &c.

There are two pages and a half of closely printed praise, of which the above specimens may suffice ; but there is not a word of the statue of the dead from beginning to end. I am myself in the habit of considering this rather an important part of a tomb, and I was especially interested in it here, because Selvatico only echoes the praise of thousands. It is unanimously declared the chef d'œuvre of Renaissance sepulchral work, and pronounced by Cicognara (also quoted by Selvatico)

“Il vertice a cui l' arti Veneziane si spinsero col ministero del scalpello,”—“The very culminating point to which the Venetian arts attained by ministry of the chisel.”

To this culminating point, therefore, covered with dust and cobwebs, I attained, as I did to every tomb of importance in Venice, by the ministry of such ancient ladders as were to be found in the sacristan's keeping. I was struck at first by the excessive awkwardness and want of feeling in the fall of the hand towards the spectator, for it is thrown off the middle of the body in order to show its fine cutting. Now the Mocenigo hand, severe and even stiff in its articulations, has its veins finely drawn, its sculptor having justly felt that the delicacy of the veining expresses alike dignity and age and birth. The Vendramin hand is far more laboriously cut, but its blunt

and clumsy contour at once makes us feel that all the care has been thrown away, and well it may be, for it has been entirely bestowed in cutting gouty wrinkles about the joints. Such as the hand is, I looked for its fellow. At first I thought it had been broken off, but, on clearing away the dust, I saw the wretched effigy had only *one* hand, and was a mere block on the inner side. The face, heavy and disagreeable in its features, is made monstrous by its semi-sculpture. One side of the forehead is wrinkled elaborately, the other left smooth; one side only of the doge's cap is chased; one cheek only is finished, and the other blocked out and distorted besides; finally, the ermine robe, which is elaborately imitated to its utmost lock of hair and of ground hair on the one side, is blocked out only on the other: it having been supposed throughout the work that 'he effigy was only to be seen from below, and from one side.

§ XLIII. It was indeed to be so seen by nearly every one; and I do not blame—I should, on the contrary, have praised—the sculptor for regulating his treatment of it by its position; if that treatment had not involved, first, dishonesty, in giving only half a face, a monstrous mask, when we demanded true portraiture of the dead; and, secondly, such utter coldness of feeling, as could only consist with an extreme of intellectual and moral degradation: Who, with a heart in his breast, could have stayed his hand as he drew the dim lines of the old man's countenance—unmajestic once, indeed, but at least sanctified by the solemnities of death—could have stayed his hand, as he reached the bend of the grey forehead, and measured out the last veins of it at so much the zecchin?

I do not think the reader, if he has feeling, will expect that much talent should be shown in the rest of his work, by the sculptor of this base and senseless lie. The whole monument is one wearisome aggregation of that species of ornamental flourish, which, when it is done with a pen, is called penmanship, and when done with a chisel, should be called chisel-manship; the subject of it being chiefly fat-limbed boys sprawling on dolphins, dolphins incapable of swimming, and dragged along the sea by expanded pocket-handkerchiefs.

But now, reader, comes the very gist and point of the whole matter. This lying monument to a dishonored doge, this culminating pride of the Renaissance art of Venice, is at least veracious, if in nothing else, in its testimony to the character of its sculptor. *He was banished from Venice for forgery in 1487.**

§ XLIV. I have more to say about this convict's work hereafter ; but I pass at present, to the second, slighter, but yet more interesting piece of evidence, which I promised.

The ducal palace has two principal façades ; one towards the sea, the other towards the Piazzetta. The seaward side, and, as far as the seventh main arch inclusive, the Piazzetta side, is work of the early part of the fourteenth century, some of it perhaps even earlier ; while the rest of the Piazzetta side is of the fifteenth. The difference in age has been gravely disputed by the Venetian antiquaries, who have examined many documents on the subject, and quoted some which they never examined. I have myself collated most of the written documents, and one document more, to which the Venetian antiquaries never thought of referring,—the masonry of the palace itself.

§ XLV. That masonry changes at the centre of the eighth arch from the sea angle on the Piazzetta side. It has been of comparatively small stones up to that point ; the fifteenth century work instantly begins with larger stones, “brought from Istria, a hundred miles away.” † The ninth shaft from the sea in the lower arcade, and the seventeenth, which is above it, in the upper arcade, commence the series of fifteenth century shafts. These two are somewhat thicker than the others, and carry the party-wall of the Sala del Scrutinio. Now observe, reader. The face of the palace, from this point to the Porta della Carta, was built at the instance of that noble Doge Mocenigo beside whose tomb you have been standing ; at his instance, and in the beginning of the reign of his successor, Foscari ; that is to say, circa 1424. This is not disputed ; it is only disputed that the sea façade is earlier ;

* Selvatico, p. 221.

† The older work is of Istrian stone also, but of different quality.

of which, however, the proofs are as simple as they are incontrovertible : for not only the masonry, but the sculpture, changes at the ninth lower shaft, and that in the capitals of the shafts both of the upper and lower arcade : the costumes of the figures introduced in the sea façade being purely Giottesque, correspondent with Giotto's work in the Arena Chapel at Padua, while the costume on the other capitals is Renaissance-Classic : and the lions' heads between the arches change at the same point. And there are a multitude of other evidences in the statues of the angels, with which I shall not at present trouble the reader.

§ XLVI. Now, the architect who built under Foscari, in 1424 (remember my date for the decline of Venice, 1418), was obliged to follow the principal forms of the older palace. But he had not the wit to invent new capitals in the same style ; he therefore clumsily copied the old ones. The palace has seventeen main arches on the sea façade, eighteen on the Piazzetta side, which in all are of course carried by thirty-six pillars ; and these pillars I shall always number from right to left, from the angle of the palace at the Ponte della Paglia to that next the Porta della Carta. I number them in this succession, because I thus have the earliest shafts first numbered. So counted, the 1st, the 18th, and the 36th, are the great supports of the angles of the palace ; and the first of the fifteenth century series, being, as above stated, the 9th from the sea on the Piazzetta side, is the 26th of the entire series, and will always in future be so numbered, so that all numbers above twenty-six indicate fifteenth century work, and all below it, fourteenth century, with some exceptional cases of restoration.

Then the copied capitals are : the 28th, copied from the 7th ; the 29th, from the 9th ; the 30th, from the 10th ; the 31st, from the 8th ; the 33d, from the 12th ; and the 34th, from the 11th ; the others being dull inventions of the 15th century, except the 36th, which is very nobly designed.

§ XLVII. The capitals thus selected from the earlier portion of the palace for imitation, together with the rest, will be accurately described hereafter ; the point I have here to notice

is in the copy of the ninth capital, which was decorated (being, like the rest, octagonal) with figures of the eight Virtues:—Faith, Hope, Charity, Justice, Temperance, Prudence, Humility (the Venetian antiquaries call it Humanity!), and Fortitude. The Virtues of the fourteenth century are somewhat hard-featured; with vivid and living expression, and plain every-day clothes of the time. Charity has her lap full of apples (perhaps loaves), and is giving one to a little child, who stretches his arm for it across a gap in the leafage of the capital. Fortitude tears open a lion's jaws; Faith lays her hand on her breast, as she beholds the Cross; and Hope is praying, while above her a hand is seen emerging from sunbeams—the hand of God (according to that of Revelations, “The Lord God giveth them light”); and the inscription above is, “Spes optima in Deo.”

§ XLVIII. This design, then, is, rudely and with imperfect chiselling, imitated by the fifteenth century workmen: the Virtues have lost their hard features and living expression; they have now all got Roman noses, and have had their hair curled. Their actions and emblems are, however, preserved until we come to Hope: she is still praying, but she is praying to the sun only: *The hand of God is gone.*

Is not this a curious and striking type of the spirit which had then become dominant in the world, forgetting to see God's hand in the light He gave; so that in the issue, when that light opened into the Reformation on the one side, and into full knowledge of ancient literature on the other, the one was arrested and the other perverted?

§ XLIX. Such is the nature of the accidental evidence on which I shall depend for the proof of the inferiority of character in the Renaissance workmen. But the proof of the inferiority of the work itself is not so easy, for in this I have to appeal to judgments which the Renaissance work has itself distorted. I felt this difficulty very forcibly as I read a slight review of my former work, “The Seven Lamps,” in “The Architect:” the writer noticed my constant praise of St. Mark's: “Mr. Ruskin thinks it a very beautiful building! We,” said the Architect, “think it a very ugly building.” I

was not surprised at the difference of opinion, but at the thing being considered so completely a subject of opinion. My opponents in matters of painting always assume that there is such a thing as a law of right, and that I do not understand it: but my architectural adversaries appeal to no law, they simply set their opinion against mine; and indeed there is no law at present to which either they or I can appeal. No man can speak with rational decision of the merits or demerits of buildings: he may with obstinacy; he may with resolved adherence to previous prejudices; but never as if the matter could be otherwise decided than by a majority of votes, or pertinacity of partizanship. I had always, however, a clear conviction that there *was* a law in this matter: that good architecture might be indisputably discerned and divided from the bad; that the opposition in their very nature and essence was clearly visible; and that we were all of us just as unwise in disputing about the matter without reference to principle, as we should be for debating about the genuineness of a coin, without ringing it. I felt also assured that this law must be universal if it were conclusive; that it must enable us to reject all foolish and base work, and to accept all noble and wise work, without reference to style or national feeling; that it must sanction the design of all truly great nations and times, Gothic or Greek or Arab; that it must cast off and reprobate the design of all foolish nations and times, Chinese or Mexican, or modern European: and that it must be easily applicable to all possible architectural inventions of human mind. I set myself, therefore, to establish such a law, in full belief that men are intended, without excessive difficulty, and by use of their general common sense, to know good things from bad; and that it is only because they will not be at the pains required for the discernment, that the world is so widely encumbered with forgeries and basenesses. I found the work simpler than I had hoped; the reasonable things ranged themselves in the order I required, and the foolish things fell aside, and took themselves away so soon as they were looked in the face. I had then, with respect to Venetian architecture, the choice, either to establish each division of law in a separate form, as I came to the

features with which it was concerned, or else to ask the reader's patience, while I followed out the general inquiry first, and determined with him a code of right and wrong, to which we might together make retrospective appeal. I thought this the best, though perhaps the dullest way; and in these first following pages I have therefore endeavored to arrange those foundations of criticism, on which I shall rest in my account of Venetian architecture, in a form clear and simple enough to be intelligible even to those who never thought of architecture before. To those who have, much of what is stated in them will be well known or self-evident; but they must not be indignant at a simplicity on which the whole argument depends for its usefulness. From that which appears a mere truism when first stated, they will find very singular consequences sometimes following,—consequences altogether unexpected, and of considerable importance; I will not pause here to dwell on their importance, nor on that of the thing itself to be done; for I believe most readers will at once admit the value of a criterion of right and wrong in so practical and costly an art as architecture, and will be apt rather to doubt the possibility of its attainment than dispute its usefulness if attained. I invite them, therefore, to a fair trial, being certain that even if I should fail in my main purpose, and be unable to induce in my reader the confidence of judgment I desire, I shall at least receive his thanks for the suggestion of consistent reasons, which may determine hesitating choice, or justify involuntary preference. And if I should succeed, as I hope, in making the Stones of Venice touchstones, and detecting, by the mouldering of her marble, poison more subtle than ever was betrayed by the rending of her crystal; and if thus I am enabled to show the baseness of the schools of architecture and nearly every other art, which have for three centuries been predominant in Europe, I believe the result of the inquiry may be serviceable for proof of a more vital truth than any at which I have hitherto hinted. For observe: I said the Protestant had despised the arts, and the Rationalist corrupted them. But what has the Romanist done meanwhile? He boasts that it was the papacy which raised the arts; why could it not sup-

port them when it was left to its own strength? How came it to yield to Classicalism which was based on infidelity, and to oppose no barrier to innovations, which have reduced the once faithfully conceived imagery of its worship to stage decoration? Shall we not rather find that Romanism, instead of being a promoter of the arts, has never shown itself capable of a single great conception since the separation of Protestantism from its side? * So long as, corrupt though it might be, no clear witness had been borne against it, so that it still included in its ranks a vast number of faithful Christians, so long its arts were noble. But the witness was borne—the error made apparent; and Rome refusing to hear the testimony or forsake the falsehood, has been struck from that instant with an intellectual palsy, which has not only incapacitated her from any further use of the arts which once were her ministers, but has made her worship the shame of its own shrines, and her worshippers their destroyers. Come, then, if truths such as these are worth our thoughts; come, and let us know, before we enter the streets of the Sea city, whether we are indeed to submit ourselves to their undistinguished enchantment, and to look upon the last changes which were wrought on the lifted forms of her palaces, as we should on the capricious towering of summer clouds in the sunset, ere they sank into the deep of night; or whether, rather, we shall not behold in the brightness of their accumulated marble, pages on which the sentence of her luxury was to be written until the waves should efface it, as they fulfilled—“God has numbered thy kingdom, and finished it.”

CHAPTER II.

THE VIRTUES OF ARCHITECTURE.

§ I. We address ourselves, then, first to the task of determining some law of right which we may apply to the architecture of all the world and of all time; and by help of which, and judgment according to which, we may easily pronounce

* Appendix 12, “Romanist Modern Art.”

whether a building is good or noble, as, by applying a plumb-line, whether it be perpendicular.

The first question will of course be, What are the possible Virtues of architecture ?

In the main, we require from buildings, as from men, two kinds of goodness: first, the doing their practical duty well: then that they be graceful and pleasing in doing it; which last is itself another form of duty.

Then the practical duty divides itself into two branches,—acting and talking:—acting, as to defend us from weather or violence; talking, as the duty of monuments or tombs, to record facts and express feelings; or of churches, temples, public edifices, treated as books of history, to tell such history clearly and forcibly.

We have thus, altogether, three great branches of architectural virtue, and we require of any building,—

1. That it act well, and do the things it was intended to do in the best way.
2. That it speak well, and say the things it was intended to say in the best words.
3. That it look well, and please us by its presence, whatever it has to do or say.*

§ II. Now, as regards the second of these virtues, it is evident that we can establish no general laws. First, because it is not a virtue required in all buildings; there are some which are only for covert or defence, and from which we ask no conversation. Secondly, because there are countless methods of expression, some conventional, some natural: each conventional mode has its own alphabet, which evidently can be no subject of general laws. Every natural mode is instinctively employed and instinctively understood, wherever there is true feeling; and this instinct is above law. The choice of conventional methods depends on circumstances out of calculation, and that of natural methods on sensations out of control; so that we can only say that the choice is right, when we feel that the means are effective; and we cannot always say that it is wrong when they are not so.

* Appendix 13. "Mr. Fergusson's System."

A building which recorded the Bible history by means of a series of sculptural pictures, would be perfectly useless to a person unacquainted with the Bible beforehand ; on the other hand, the text of the Old and New Testaments might be written on its walls, and yet the building be a very inconvenient kind of book, not so useful as if it had been adorned with intelligible and vivid sculpture. So, again, the power of exciting emotion must vary or vanish, as the spectator becomes thoughtless or cold ; and the building may be often blamed for what is the fault of its critic, or endowed with a charm which is of its spectator's creation. It is not, therefore, possible to make expressional character any fair criterion of excellence in buildings, until we can fully place ourselves in the position of those to whom their expression was originally addressed, and until we are certain that we understand every symbol, and are capable of being touched by every association which its builders employed as letters of their language. I shall continually endeavor to put the reader into such sympathetic temper, when I ask for his judgment of a building ; and in every work I may bring before him I shall point out, as far as I am able, whatever is peculiar in its expression ; nay, I must even depend on such peculiarities for much of my best evidence respecting the character of the builders. But I cannot legalize the judgment for which I plead, nor insist upon it if it be refused. I can neither force the reader to feel this architectural rhetoric, nor compel him to confess that the rhetoric is powerful, if it have produced no impression on his own mind.

§ III. I leave, therefore, the expression of buildings for incidental notice only. But their other two virtues are proper subjects of law,—their performance of their common and necessary work, and their conformity with universal and divine canons of loveliness : respecting these there can be no doubt, no ambiguity. I would have the reader discern them, so quickly that, as he passes along a street, he may, by a glance of the eye distinguish the noble from the ignoble work. He can do this, if he permit free play to his natural instincts ; and all that I have to do for him is to remove from those in-

instincts the artificial restraints which prevent their action, and to encourage them to an unaffected and unbiassed choice between right and wrong.

§ iv. We have, then, two qualities of buildings for subjects of separate inquiry : their action, and aspect, and the sources of virtue in both ; that is to say, Strength and Beauty, both of these being less admired in themselves, than as testifying the intelligence or imagination of the builder.

For we have a worthier way of looking at human than at divine architecture : much of the value both of construction and decoration, in the edifices of men, depends upon our being led by the thing produced or adorned, to some contemplation of the powers of mind concerned in its creation or adornment. We are not so led by divine work, but are content to rest in the contemplation of the thing created. I wish the reader to note this especially : we take pleasure, or *should* take pleasure, in architectural construction altogether as the manifestation of an admirable human intelligence ; it is not the strength, not the size, not the finish of the work which we are to venerate : rocks are always stronger, mountains always larger, all natural objects more finished ; but it is the intelligence and resolution of man in overcoming physical difficulty which are to be the source of our pleasure and subject of our praise. And again, in decoration or beauty, it is less the actual loveliness of the thing produced, than the choice and invention concerned in the production, which are to delight us ; the love and the thoughts of the workman more than his work : his work must always be imperfect, but his thoughts and affections may be true and deep.

§ v. This origin of our pleasure in architecture I must insist upon at somewhat greater length, for I would fain do away with some of the ungrateful coldness which we show towards the good builders of old time. In no art is there closer connection between our delight in the work, and our admiration of the workman's mind, than in architecture, and yet we rarely ask for a builder's name. The patron at whose cost, the monk through whose dreaming, the foundation was laid, we remember occasionally ; never the man who verily did the

work. Did the reader ever hear of William of Sens as having had anything to do with Canterbury Cathedral? or of Pietro Basegio as in anywise connected with the Ducal Palace of Venice? There is much ingratitude and injustice in this; and therefore I desire my reader to observe carefully how much of his pleasure in building is derived, or should be derived, from admiration of the intellect of men whose names he knows not.

§ VI. The two virtues of architecture which we can justly weigh, are, we said, its strength or good construction, and its beauty or good decoration. Consider first, therefore, what you mean when you say a building is well constructed or well built; you do not merely mean that it answers its purpose,—this is much, and many modern buildings fail of this much; but if it be verily well built, it must answer this purpose in the simplest way, and with no over-expenditure of means. We require of a light-house, for instance, that it shall stand firm and carry a light; if it do not this, assuredly it has been ill built; but it may do it to the end of time, and yet not be well built. It may have hundreds of tons of stone in it more than were needed, and have cost thousands of pounds more than it ought. To pronounce it well or ill built, we must know the utmost forces it can have to resist, and the best arrangements of stone for encountering them, and the quickest ways of effecting such arrangements: then only, so far as such arrangements have been chosen, and such methods used, is it well built. Then the knowledge of all difficulties to be met, and of all means of meeting them, and the quick and true fancy or invention of the modes of applying the means to the end, are what we have to admire in the builder, even as he is seen through this first or inferior part of his work. Mental power, observe: not muscular nor mechanical, nor technical, nor empirical,—pure, precious, majestic, massy intellect; not to be had at vulgar price, nor received without thanks, and without asking from whom.

§ VII. Suppose, for instance, we are present at the building of a bridge: the bricklayers or masons have had their centring erected for them, and that centring was put together

by a carpenter, who had the line of its curve traced for him by the architect: the masons are dexterously handling and fitting their bricks, or, by the help of machinery, carefully adjusting stones which are numbered for their places. There is probably in their quickness of eye and readiness of hand something admirable; but this is not what I ask the reader to admire: not the carpentering, nor the bricklaying, nor anything that he can presently see and understand, but the choice of the curve, and the shaping of the numbered stones, and the appointment of that number; there were many things to be known and thought upon before these were decided. The man who chose the curve and numbered the stones, had to know the times and tides of the river, and the strength of its floods, and the height and flow of them, and the soil of the banks, and the endurance of it, and the weight of the stones he had to build with, and the kind of traffic that day by day would be carried on over his bridge,—all this specially, and all the great general laws of force and weight, and their working; and in the choice of the curve and numbering of stones are expressed not only his knowledge of these, but such ingenuity and firmness as he had, in applying special means to overcome the special difficulties about his bridge. There is no saying how much wit, how much depth of thought, how much fancy, presence of mind, courage, and fixed resolution there may have gone to the placing of a single stone of it. This is what we have to admire,—this grand power and heart of man in the thing; not his technical or empirical way of holding the trowel and laying mortar.

§ VIII. Now there is in everything properly called art this concernment of the intellect, even in the province of the art which seems merely practical. For observe: in this bridge-building I suppose no reference to architectural principles; all that I suppose we want is to get safely over the river; the man who has taken us over is still a mere bridge-builder,—a *builder*, not an architect: he may be a rough, artless, feelingless man, incapable of doing any one truly fine thing all his days. I shall call upon you to despise him presently in a sort, but not as if he were a mere smother of mortar; perhaps a

great man, infinite in memory, indefatigable in labor, exhaustless in expedient, unsurpassable in quickness of thought. Take good heed you understand him before you despise him.

§ ix. But why is he to be in anywise despised? By no means despise him, unless he happen to be without a soul,* or at least to show no signs of it; which possibly he may not in merely carrying you across the river. He may be merely what Mr. Carlyle rightly calls a human beaver after all; and there may be nothing in all that ingenuity of his greater than a complication of animal faculties, an intricate bestiality,—nest or hive building in its highest development. You need something more than this, or the man is despicable; you need that virtue of building through which he may show his affections and delights; you need its beauty or decoration.

§ x. Not that, in reality, one division of the man is more human than another. Theologians fall into this error very fatally and continually; and a man from whom I have learned much, Lord Lindsay, has hurt his noble book by it, speaking as if the spirit of the man only were immortal, and were opposed to his intellect, and the latter to the senses; whereas all the divisions of humanity are noble or brutal, immortal or mortal, according to the degree of their sanctification: and there is no part of the man which is not immortal and divine when it is once given to God, and no part of him which is not mortal by the second death, and brutal before the first, when it is withdrawn from God. For to what shall we trust for our distinction from the beasts that perish? To our higher intellect?—yet are we not bidden to be wise as the serpent, and to consider the ways of the ant?—or to our affections? nay; these are more shared by the lower animals than our intelligence. Hamlet leaps into the grave of his beloved, and leaves it,—a dog had stayed. Humanity and immortality consist neither in reason, nor in love; not in the body, nor in the animation of the heart of it, nor in the thoughts and stirrings of the brain of it,—but in the dedication of them all to Him who will raise them up at the last day.

* Appendix 14, "Divisions of Humanity."

§ XI. It is not, therefore, that the signs of his affections, which man leaves upon his work, are indeed more ennobling than the signs of his intelligence; but it is the balance of both whose expression we need, and the signs of the government of them all by Conscience; and Discretion, the daughter of Conscience. So, then, the intelligent part of man being eminently, if not chiefly, displayed in the structure of his work, his affectionate part is to be shown in its decoration; and, that decoration may be indeed lovely, two things are needed: first, that the affections be vivid, and honestly shown; secondly, that they be fixed on the right things.

§ XII. You think, perhaps, I have put the requirements in wrong order. Logically I have; practically I have not: for it is necessary first to teach men to speak out, and say what they like, truly; and, in the second place, to teach them which of their likings are ill set, and which justly. If a man is cold in his likings and dislikings, or if he will not tell you what he likes, you can make nothing of him. Only get him to feel quickly and to speak plainly, and you may set him right. And the fact is, that the great evil of all recent architectural effort has not been that men liked wrong things: but that they either cared nothing about any, or pretended to like what they did not. Do you suppose that any modern architect likes what he builds, or enjoys it? Not in the least. He builds it because he has been told that such and such things are fine, and that he *should* like them. He pretends to like them, and gives them a false relish of vanity. Do you seriously imagine, reader, that any living soul in London likes triglyphs? *—or gets any hearty enjoyment out of pediments? † You are much mistaken. Greeks did: English people never did,—never will. Do you fancy that the architect of old Burlington Mews, in Regent Street, had any particular satisfaction in putting the blank triangle over the

* Triglyph. Literally, "Three Cut." The awkward upright ornament with two notches in it, and a cut at each side, to be seen everywhere at the tops of Doric colonnades, ancient and modern.

† Pediment. The triangular space above Greek porticos, as on the Mansion House or Royal Exchange.

archway, instead of a useful garret window? By no manner of means. He had been told it was right to do so, and thought he should be admired for doing it. Very few faults of architecture are mistakes of honest choice: they are almost always hypocrisies.

§ XIII. So, then, the first thing we have to ask of the decoration is that it should indicate strong liking, and that honestly. It matters not so much what the thing is, as that the builder should really love it and enjoy it, and say so plainly. The architect of Bourges Cathedral liked hawthorns; so he has covered his porch with hawthorn,—it is a perfect Niobe of May. Never was such hawthorn; you would try to gather it forthwith, but for fear of being pricked. The old Lombard architects liked hunting; so they covered their work with horses and hounds, and men blowing trumpets two yards long. The base Renaissance architects of Venice liked masquing and fiddling; so they covered their work with comic masks and musical instruments. Even that was better than our English way of liking nothing; and professing to like tri-glyphs.

§ XIV. But the second requirement in decoration, is a sign of our liking the right thing. And the right thing to be liked is God's work, which He made for our delight and contentment in this world. And all noble ornamentation is the expression of man's delight in God's work.

§ XV. So, then, these are the two virtues of building: first, the signs of man's own good work; secondly, the expression of man's delight in better work than his own. And these are the two virtues of which I desire my reader to be able quickly to judge, at least in some measure; to have a definite opinion up to a certain point. Beyond a certain point he cannot form one. When the science of the building is great, great science is of course required to comprehend it: and, therefore, of difficult bridges, and light-houses, and harbor walls, and river dykes, and railway tunnels, no judgment may be rapidly formed. But of common buildings, built in common circumstances, it is very possible for every man, or woman, or child, to form judgment both rational and rapid. Their necessary,

or even possible, features are but few ; the laws of their construction are as simple as they are interesting. The labor of a few hours is enough to render the reader master of their main points ; and from that moment he will find in himself a power of judgment which can neither be escaped nor deceived, and discover subjects of interest where everything before had appeared barren. For though the laws are few and simple, the modes of obedience to them are not so. Every building presents its own requirements and difficulties ; and every good building has peculiar appliances or contrivances to meet them. Understand the laws of structure, and you will feel the special difficulty in every new building which you approach ; and you will know also, or feel instinctively,* whether it has been wisely met or otherwise. And an enormous number of buildings, and of styles of buildings, you will be able to cast aside at once, as at variance with these constant laws of structure, and therefore unnatural and monstrous.

§ XVI. Then, as regards decoration, I want you only to consult your own natural choice and liking. There is a right and wrong in it ; but you will assuredly like the right if you suffer your natural instinct to lead you. (Half the evil in this world comes from people not knowing what they do like, not deliberately setting themselves to find out what they really enjoy.) All people enjoy giving away money, for instance : they don't know *that*,—they rather think they like keeping it ; and they *do* keep it under this false impression, often to their great discomfort. Every body likes to do good ; but not one in a hundred finds *this* out. (Multitudes think they like to do evil ; yet no man ever really enjoyed doing evil since God made the world.)

So in this lesser matter of ornament. It needs some little care to try experiments upon yourself : it needs deliberate question and upright answer. But there is no difficulty to be overcome, no abstruse reasoning to be gone into ; only a little watchfulness needed, and thoughtfulness, and so much honesty as will enable you to confess to yourself and to all men, that you enjoy things, though great authorities say you should not.

* Appendix 15 : " Instinctive Judgments."

§ XVII. This looks somewhat like pride ; but it is true humility, a trust that you have been so created as to enjoy what is fitting for you, and a willingness to be pleased, as it was intended you should be. It is the child's spirit, which we are then most happy when we most recover ; only wiser than children in that we are ready to think it subject of thankfulness that we can still be pleased with a fair color or a dancing light. And, above all, do not try to make all these pleasures reasonable, nor to connect the delight which you take in ornament with that which you take in construction or usefulness. They have no connection ; and every effort that you make to reason from one to the other will blunt your sense of beauty, or confuse it with sensations altogether inferior to it. You were made for enjoyment, and the world was filled with things which you will enjoy, unless you are too proud to be pleased by them, or too grasping to care for what you cannot turn to other account than mere delight. Remember that the most beautiful things in the world are the most useless ; peacocks and lilies for instance ; at least I suppose this quill I hold in my hand writes better than a peacock's would, and the peasants of Vevay, whose fields in spring time are as white with lilies as the Dent du Midi is with its snow, told me the hay was none the better for them.

§ XVIII. Our task therefore divides itself into two branches, and these I shall follow in succession. I shall first consider the construction of buildings, dividing them into their really necessary members or features ; and I shall endeavor so to lead the reader forward from the foundation upwards, as that he may find out for himself the best way of doing everything, and having so discovered it, never forget it. I shall give him stones, and bricks, and straw, chisels, and trowels, and the ground, and then ask him to build ; only helping him, as I can, if I find him puzzled. And when he has built his house or church, I shall ask him to ornament it, and leave it to him to choose the ornaments as I did to find out the construction : I shall use no influence with him whatever, except to counteract previous prejudices, and leave him, as far as may be, free. And when he has thus found out how to build, and chosen

his forms of decoration, I shall do what I can to confirm his confidence in what he has done. I shall assure him that no one in the world could, so far, have done better, and require him to condemn, as futile or fallacious, whatever has no resemblance to his own performances.

CHAPTER III.

THE SIX DIVISIONS OF ARCHITECTURE.

§ I. The practical duties of buildings are twofold.

They have either (1), to hold and protect something ; or (2), to place or carry something.

1. Architecture of Protection. This is architecture intended to protect men or their possessions from violence of any kind, whether of men or of the elements. It will include all churches, houses, and treasuries ; fortresses, fences, and ramparts ; the architecture of the hut and sheepfold ; of the palace and the citadel : of the dyke, breakwater, and sea-wall. And the protection, when of living creatures, is to be understood as including commodiousness and comfort of habitation, wherever these are possible under the given circumstances.

2. Architecture of Position. This is architecture intended to carry men or things to some certain places, or to hold them there. This will include all bridges, aqueducts, and road architecture ; light-houses, which have to hold light in appointed places ; chimneys to carry smoke or direct currents of air ; staircases ; towers, which are to be watched from or cried from, as in mosques, or to hold bells, or to place men in positions of offence, as ancient moveable attacking towers, and most fortress towers.

§ II. Protective architecture has to do one or all of three things : to wall a space, to roof it, and to give access to it, of

persons, light, and air ; and it is therefore to be considered under the three divisions of walls, roofs, and apertures.

We will take, first, a short, general view of the connection of these members, and then examine them in detail : endeavoring always to keep the simplicity of our first arrangement in view ; for protective architecture has indeed no other members than these, unless flooring and paving be considered architecture, which it is only when the flooring is also a roof ; the laying of the stones or timbers for footing being pavior's or carpenter's work, rather than architect's ; and, at all events, work respecting the well or ill doing of which we shall hardly find much difference of opinion, except in points of æsthetics. We shall therefore concern ourselves only with the construction of walls, roofs, and apertures.

§ III. 1. *Walls*.—A wall is an even and united fence, whether of wood, earth, stone, or metal. When meant for purposes of mere partition or enclosure, it remains a wall proper : but it has generally also to sustain a certain vertical or lateral pressure, for which its strength is at first increased by some general addition to its thickness ; but if the pressure becomes very great, it is gathered up into *piers* to resist vertical pressure, and supported by *buttresses* to resist lateral pressure.

If its functions of partition or enclosure are continued, together with that of resisting vertical pressure, it remains as a wall veil between the piers into which it has been partly gathered ; but if it is required only to resist the vertical or roof pressure, it is gathered up into piers altogether, loses its wall character, and becomes a group or line of piers.

On the other hand, if the lateral pressure be slight, it may retain its character of a wall, being supported against the pressure by buttresses at intervals ; but if the lateral pressure be very great, it is supported against such pressure by a continuous buttress, loses its wall character, and becomes a dyke or rampart.

§ IV. We shall have therefore (A) first to get a general idea of a wall, and of right construction of walls ; then (B) to see how this wall is gathered into piers ; and to get a general idea

of piers and the right construction of piers ; then (C) to see how a wall is supported by buttresses, and to get a general idea of buttresses and the right construction of buttresses. This is surely very simple, and it is all we shall have to do with walls and their divisions.

§ v. 2. *Roofs*.—A roof is the covering of a space, narrow or wide. It will be most conveniently studied by first considering the forms in which it may be carried over a narrow space, and then expanding these on a wide plan ; only there is some

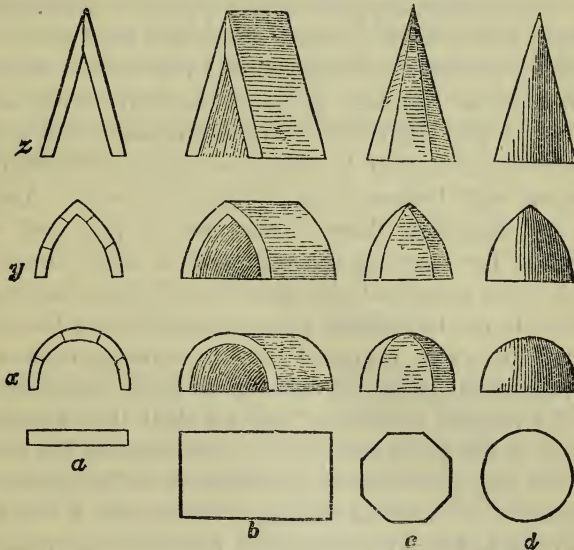

FIG. 1.

difficulty here in the nomenclature, for an arched roof over a narrow space has (I believe) no name, except that which belongs properly to the piece of stone or wood composing such a roof, namely, lintel. But the reader will have no difficulty in understanding that he is first to consider roofs on the section only, thinking how best to construct a narrow bar or slice of them, of whatever form ; as, for instance, *x*, *y*, or *z*, over the plan or area *a*, Fig. I. Having done this, let him imagine these several divisions, first moved along (or set side by side)

over a rectangle, *b*, Fig. I., and then revolved round a point (or crossed at it) over a polygon, *c*, or circle, *d*, and he will have every form of simple roof : the arched section giving successively the vaulted roof and dome, and the gabled section giving the gabled roof and spire.

As we go farther into the subject, we shall only have to add one or two forms to the sections here given, in order to embrace all the *uncombined* roofs in existence ; and we shall not trouble the reader with many questions respecting cross-vaulting, and other modes of their combination.

§ VI. Now, it also happens, from its place in buildings, that the sectional roof over a narrow space will need to be considered before we come to the expanded roof over a broad one. For when a wall has been gathered, as above explained, into piers, that it may better bear vertical pressure, it is generally necessary that it should be expanded again at the top into a continuous wall before it carries the true roof. Arches or lintels are, therefore, thrown from pier to pier, and a level preparation for carrying the real roof is made above them. After we have examined the structure of piers, therefore, we shall have to see how lintels or arches are thrown from pier to pier, and the whole prepared for the superincumbent roof ; this arrangement being universal in all good architecture prepared for vertical pressures ; and we shall then examine the condition of the great roof itself. And because the structure of the roof very often introduces certain lateral pressures which have much to do with the placing of buttresses, it will be well to do all this before we examine the nature of buttresses, and, therefore, between parts (B) and (C) of the above plan, § IV. So now we shall have to study : (A) the construction of walls ; (B) that of piers ; (C) that of lintels or arches prepared for roofing ; (D) that of roofs proper ; and (E) that of buttresses.

§ VII. 3. *Apertures*.—There must either be intervals between the piers, of which intervals the character will be determined by that of the piers themselves, or else doors or windows in the walls proper. And, respecting doors or windows, we have to determine three things : first, the proper shape of the entire aperture ; secondly, the way in which it is to be filled with

valves or glass ; and thirdly, the modes of protecting it on the outside, and fitting appliances of convenience to it, as porches or balconies. And this will be our division F ; and if the reader will have the patience to go through these six heads, which include every possible feature of protective architecture, and to consider the simple necessities and fitnesses of each, I will answer for it, he shall never confound good architecture with bad any more. For, as to architecture of position, a great part of it involves necessities of construction with which the spectator cannot become generally acquainted, and of the compliance with which he is therefore never expected to judge,—as in chimneys, light-houses, &c. : and the other forms of it are so closely connected with those of protective architecture, that a few words in Chap. XIX. respecting staircases and towers, will contain all with which the reader need be troubled on the subject.

CHAPTER IV.

THE WALL BASE.

§ I. OUR first business, then, is with Wall, and to find out wherein lies the true excellence of the “Wittiest Partition.” For it is rather strange that, often as we speak of a “dead” wall, and that with considerable disgust, we have not often, since Snout’s time, heard of a living one. But the common epithet of opprobrium is justly bestowed, and marks a right feeling. A wall has no business to be dead. It ought to have members in its make, and purposes in its existence, like an organized creature, and to answer its ends in a living and energetic way ; and it is only when we do not choose to put any strength nor organization into it, that it offends us by its deadness. Every wall ought to be a “sweet and lovely wall.” I do not care about its having ears ; but, for instruction and exhortation, I would often have it to “hold up its fingers.” What its necessary members and excellences are, it is our present business to discover.

§ II. A wall has been defined to be an even and united fence of wood, earth, stone, or metal. Metal fences, however, seldom, if ever, take the form of walls, but of railings; and, like all other metal constructions, must be left out of our present investigation; as may be also walls composed merely of light planks or laths for purposes of partition or inclosure. Substantial walls, whether of wood or earth (I use the word earth as including clay, baked or unbaked, and stone), have, in their perfect form, three distinct members:—the Foundation, Body or Veil, and Cornice.

§ III. The foundation is to the wall what the paw is to an animal. It is a long foot, wider than the wall, on which the wall is to stand, and which keeps it from settling into the ground. It is most necessary that this great element of security should be visible to the eye, and therefore made a part of the structure above ground. Sometimes, indeed, it becomes incorporated with the entire foundation of the building, a vast table on which walls or piers are alike set: but even then, the eye, taught by the reason, requires some additional preparation or foot for the wall, and the building is felt to be imperfect without it. This foundation we shall call the Base of the wall.

§ IV. The body of the wall is of course the principal mass of it, formed of mud or clay, of bricks or stones, of logs or hewn timber; the condition of structure being, that it is of equal thickness everywhere, below and above. It may be half a foot thick, or six feet thick, or fifty feet thick; but if of equal thickness everywhere, it is still a wall proper: if to its fifty feet of proper thickness there be added so much as an inch of thickness in particular parts, that added thickness is to be considered as some form of buttress or pier, or other appliance.*

In perfect architecture, however, the walls are generally

* Many walls are slightly sloped or curved towards their tops, and have buttresses added to them (that of the Queen's Bench Prison is a curious instance of the vertical buttress and inclined wall); but in all such instances the slope of the wall is properly to be considered a condition of incorporated buttress.

kept of moderate thickness, and strengthened by piers or buttresses; and the part of the wall between these, being generally intended only to secure privacy, or keep out the slighter forces of weather, may be properly called a Wall Veil. I shall always use this word "Veil" to signify the even portion of a wall, it being more expressive than the term Body.

§ v. When the materials with which this veil is built are very loose, or of shapes which do not fit well together, it sometimes becomes necessary, or at least adds to security, to introduce courses of more solid material. Thus, bricks alternate with rolled pebbles in the old walls of Verona, and hewn stones with brick in its Lombard churches. A banded structure, almost a stratification of the wall, is thus produced; and the courses of more solid material are sometimes decorated with carving. Even when the wall is not thus banded through its whole height, it frequently becomes expedient to lay a course of stone, or at least of more carefully chosen materials, at regular heights; and such belts or bands we may call String courses. These are a kind of epochs in the wall's existence; something like periods of rest and reflection in human life, before entering on a new career. Or else, in the building, they correspond to the divisions of its stories within, express its internal structure, and mark off some portion of the ends of its existence already attained.

§ vi. Finally, on the top of the wall some protection from the weather is necessary, or some preparation for the reception of superincumbent weight, called a coping, or Cornice. I shall use the word Cornice for both; for, in fact, a coping is a roof to the wall itself, and is carried by a small cornice as the roof of the building by a large one. In either case, the cornice, small or large, is the termination of the wall's existence, the accomplishment of its work. When it is meant to carry some superincumbent weight, the cornice may be considered as its hand, opened to carry something above its head; as the base was considered its foot: and the three parts should grow out of each other and form one whole, like the root, stalk, and bell of a flower.

These three parts we shall examine in succession; and, first, the Base.

§ VII. It may be sometimes in our power, and it is always expedient, to prepare for the whole building some settled foundation, level and firm, out of sight. But this has not been done in some of the noblest buildings in existence. It cannot always be done perfectly, except at enormous expense; and, in reasoning upon the superstructure, we shall never suppose it to be done. The mind of the spectator does not conceive it; and he estimates the merits of the edifice on the supposition of its being built upon the ground. Even if there be a vast table land of foundation elevated for the whole of it, accessible by steps all around, as at Pisa, the surface of this table is always conceived as capable of yielding somewhat to superincumbent weight, and generally is so; and we shall base all our arguments on the widest possible supposition, that is to say, that the building stands on a surface either of earth, or, at all events, capable of yielding in some degree to its weight.

§ VIII. Now, let the reader simply ask himself how, on such a surface, he would set about building a substantial wall,

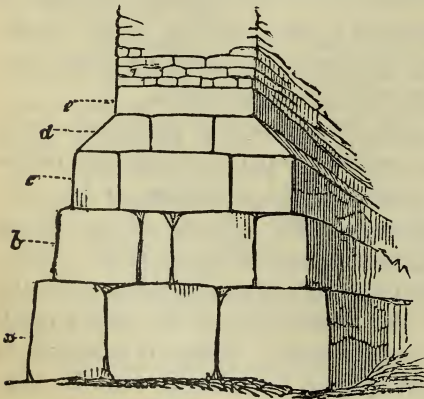

FIG. II.

that should be able to bear weight and to stand for ages. He would assuredly look about for the largest stones he had at his disposal, and, rudely levelling the ground, he would lay these well together over a considerably larger width than he required the wall to be (suppose as at *a*, Fig. II.), in order to equalise the pressure

of the wall over a large surface, and form its foot. On the top of these he would perhaps lay a second tier of large stones, *b*, or even the third, *c*, making the breadth somewhat

less each time, so as to prepare for the pressure of the wall on the centre, and, naturally or necessarily, using somewhat smaller stones above than below (since we supposed him to look about for the largest first), and cutting them more neatly. His third tier, if not his second, will probably appear a sufficiently secure foundation for finer work; for if the earth yield at all, it will probably yield pretty equally under the great mass of masonry now knit together over it. So he will prepare for the wall itself at once by sloping off the next tier of stones to the right diameter, as at *d*. If there be any joints in this tier within the wall, he may perhaps, for further security, lay a binding stone across them, *e*, and then begin the work of the wall veil itself, whether in bricks or stones.

§ ix. I have supposed the preparation here to be for a large wall, because such a preparation will give us the best general type. But it is evident that the essential features of the arrangement are only two, that is to say, one tier of massy work for foundation, suppose *c*, missing the first two; and the receding tier or real foot of the wall, *d*. The reader will find these members, though only of brick, in most of the considerable and independent walls in the suburbs of London.

§ x. It is evident, however, that the general type, Fig. 2, will be subject to many different modifications in different circumstances. Sometimes the ledges of the tiers *a* and *b* may be of greater width; and when the building is in a secure place, and of finished masonry, these may be sloped off also like the main foot *d*. In Venetian buildings these lower ledges are exposed to the sea, and therefore left rough hewn; but in fine work and in important positions the lower ledges may be bevelled and decorated like the upper, or another added above *d*; and all these parts may be in different proportions, according to the disposition of the building above them. But we have nothing to do with any of these variations at present, they being all more or less dependent upon decorative considerations, except only one of very great importance, that is to say, the widening of the lower ledge into a stone seat, which may be often done in buildings of great

size with most beautiful effect : it looks kind and hospitable, and preserves the work above from violence. In St. Mark's at Venice, which is a small and low church, and needing no great foundation for the wall veils of it, we find only the three members, *b*, *c*, and *d*. Of these the first rises about a foot above the pavement of St. Mark's Place, and forms an elevated dais in some of the recesses of the porches, chequered red and white ; *c* forms a seat which follows the line of the walls, while its basic character is marked by its also carrying certain shafts with which we have here no concern ; *d* is of white marble ; and all are enriched and decorated in the simplest and most perfect manner possible, as we shall see in Chap. XXV. And thus much may serve to fix the type of wall bases, a type oftener followed in real practice than any other we shall hereafter be enabled to determine : for wall bases of necessity must be solidly built, and the architect is therefore driven into the adoption of the right form ; or if he deviate from it, it is generally in meeting some necessity of peculiar circumstances, as in obtaining cellars and underground room, or in preparing for some grand features or particular parts of the wall, or in some mistaken idea of decoration,—into which errors we had better not pursue him until we understand something more of the rest of the building : let us therefore proceed to consider the wall veil.

CHAPTER V.

THE WALL VEIL.

§ I. THE summer of the year 1849 was spent by the writer in researches little bearing upon his present subject, and connected chiefly with proposed illustrations of the mountain forms in the works of J. M. W. Turner. But there are sometimes more valuable lessons to be learned in the school of nature than in that of Vitruvius, and a fragment of building among the Alps is singularly illustrative of the chief feature which I have at present to develop as necessary to the perfection of the wall veil.

It is a fragment of some size ; a group of broken walls, one of them overhanging ; crowned with a cornice, nodding some hundred and fifty feet over its massy flank, three thousand above its glacier base, and fourteen thousand above the sea, —a wall truly of some majesty, at once the most precipitous and the strongest mass in the whole chain of the Alps, the Mont Cervin.

§ II. It has been falsely represented as a peak or tower. It is a vast ridged promontory, connected at its western root with the Dent d'Erin, and lifting itself like a rearing horse with its face to the east. All the way along the flank of it, for half a day's journey on the Zmutt glacier, the grim black terraces of its foundations range almost without a break ; and the clouds, when their day's work is done, and they are weary, lay themselves down on those foundation steps, and rest till dawn, each with his leagues of gray mantle stretched along the grisly ledge, and the cornice of the mighty wall gleaming in the moonlight, three thousand feet above.

§ III. The eastern face of the promontory is hewn down, as if by the single sweep of a sword, from the crest of it to the base ; hewn concave and smooth, like the hollow of a wave : on each flank of it there is set a buttress, both of about equal height, their heads sloped out from the main wall about seven hundred feet below its summit. That on the north is the most important ; it is as sharp as the frontal angle of a bastion, and sloped sheer away to the north-east, throwing out spur beyond spur, until it terminates in a long low curve of russet precipice, at whose foot a great bay of the glacier of the Col de Cervin lies as level as a lake. This spur is one of the few points from which the mass of the Mont Cervin is in anywise approachable. It is a continuation of the masonry of the mountain itself, and affords us the means of examining the character of its materials.

§ IV. Few architects would like to build with them. The slope of the rocks to the north-west is covered two feet deep with their ruins, a mass of loose and slaty shale, of a dull brick-red color, which yields beneath the foot like ashes, so that, in running down, you step one yard, and slide three.

The rock is indeed hard beneath, but still disposed in thin courses of these cloven shales, so finely laid that they look in places more like a heap of crushed autumn leaves than a rock ; and the first sensation is one of unmitigated surprise, as if the mountain were upheld by miracle ; but surprise becomes more intelligent reverence for the great builder, when we find, in the middle of the mass of these dead leaves, a course of living rock, of quartz as white as the snow that encircles it, and harder than a bed of steel.

§ v. It is one only of a thousand iron bands that knit the strength of the mighty mountain. Through the buttress and the wall alike, the courses of its varied masonry are seen in their successive order, smooth and true as if laid by line and plummet,* but of thickness and strength continually varying, and with silver cornices glittering along the edge of each, laid by the snowy winds and carved by the sunshine,—stainless ornaments of the eternal temple, by which “neither the hammer nor the axe, nor any tool, was heard while it was in building.”

§ vi. I do not, however, bring this forward as an instance of any universal law of natural building ; there are solid as well as coursed masses of precipice, but it is somewhat curious that the most noble cliff in Europe, which this eastern front of the Cervin is, I believe, without dispute, should be to us an example of the utmost possible stability of precipitousness attained with materials of imperfect and variable character ; and, what is more, there are very few cliffs which do not display alternations between compact and friable conditions of their material, marked in their contours by bevelled slopes when the bricks are soft, and vertical steps when they are harder. And, although we are not hence to conclude that it is well to introduce courses of bad materials when we can get perfect material, I believe we may conclude with great certainty that it is better and easier to strengthen a wall necessarily of imperfect substance, as of brick, by introducing carefully laid courses of stone, than by adding to its thickness ;

* On the eastern side: violently contorted on the northern and western.

and the first impression we receive from the unbroken aspect of a wall veil, unless it be of hewn stone throughout, is that it must be both thicker and weaker than it would have been, had it been properly coursed. The decorative reasons for adopting the coursed arrangement, which we shall notice hereafter, are so weighty, that they would alone be almost sufficient to enforce it; and the constructive ones will apply universally, except in the rare cases in which the choice of perfect or imperfect material is entirely open to us, or where the general system of the decoration of the building requires absolute unity in its surface.

§ VII. As regards the arrangement of the intermediate parts themselves, it is regulated by certain conditions of bonding and fitting the stones or bricks, which the reader need hardly be troubled to consider, and which I wish that bricklayers themselves were always honest enough to observe. But I hardly know whether to note under the head of æsthetic or constructive law, this important principle, that masonry is always bad which appears to have arrested the attention of the architect more than absolute conditions of strength require. Nothing is more contemptible in any work than an appearance of the slightest desire on the part of the builder to *direct attention* to the way its stones are put together, or of any trouble taken either to show or to conceal it more than was rigidly necessary: it may sometimes, on the one hand, be necessary to conceal it as far as may be, by delicate and close fitting, when the joints would interfere with lines of sculpture or of mouldings; and it may often, on the other hand, be delightful to show it, as it is delightful in places to show the anatomy even of the most delicate human frame: but *studiously* to conceal it is the error of vulgar painters, who are afraid to show that their figures have bones; and studiously to display it is the error of the base pupils of Michael Angelo, who turned heroes' limbs into surgeons' diagrams,—but with less excuse than theirs, for there is less interest in the anatomy displayed. Exhibited masonry is in most cases the expedient of architects who do not know how to fill up blank spaces, and many a building, which would have been decent

enough if let alone, has been scrawled over with straight lines, as in Fig. III., on exactly the same principles, and with just the same amount of intelligence as a boy's in scrawling his copy-book when he cannot write. The device was thought ingenious at one period of architectural history ; St. Paul's and Whitehall are covered with it, and it is in this I imagine

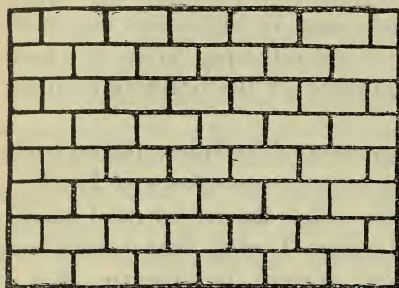

FIG. III.

that some of our modern architects suppose the great merit of those buildings to consist. There is, however, no excuse for errors in disposition of masonry, for there is but one law upon the subject, and that easily complied with, to avoid all affectation and all unnecessary

expense, either in showing or concealing. Every one knows a building is built of separate stones ; nobody will ever object to seeing that it is so, but nobody wants to count them. The divisions of a church are much like the divisions of a sermon ; they are always right so long as they are necessary to edification, and always wrong when they are thrust upon the attention as divisions only. There may be neatness in carving when there is richness in feasting ; but I have heard many a discourse, and seen many a church wall, in which it was all carving and no meat.

CHAPTER VI.

THE WALL CORNICE.

§ I. WE have lastly to consider the close of the wall's existence, or its cornice. It was above stated, that a cornice has one of two offices : if the wall have nothing to carry, the cornice is its roof, and defends it from the weather ; if there is weight to be carried above the wall, the cornice is its hand, and is expanded to carry the said weight.

There are several ways of roofing or protecting independent walls, according to the means nearest at hand : sometimes the wall has a true roof all to itself ; sometimes it terminates in a small gabled ridge, made of bricks set slanting, as constantly in the suburbs of London ; or of hewn stone, in stronger work ; or in a single sloping face, inclined to the outside. We need not trouble ourselves at present about these small roofings, which are merely the diminutions of large ones ; but we must examine the important and constant member of the wall structure, which prepares it either for these small roofs or for weights above, and is its true cornice.

§ II. The reader will, perhaps, as heretofore, be kind enough to think for himself, how, having carried up his wall veil as high as it may be needed, he will set about protecting it from weather, or preparing it for weight. Let him imagine the top of the unfinished wall, as it would be seen from above with all the joints, perhaps uncemented, or imperfectly filled up with cement, open to the sky ; and small broken materials filling gaps between large ones, and leaving cavities ready for the rain to soak into, and loosen and dissolve the cement, and split, as it froze, the whole to pieces. I am much mistaken if his first impulse would not be to take a great flat stone and lay it on the top ; or rather a series of such, side by side, projecting well over the edge of the wall veil. If, also, he proposed to lay a weight (as, for instance, the end of a beam) on the wall, he would feel at once that the pressure of this beam on, or rather among, the small stones of the wall veil, might very possibly dislodge or disarrange some of them ; and the first impulse would be, in this case, also to lay a large flat stone on the top of all to receive the beam, or any other weight, and distribute it equally among the small stones below, as at *a*, Fig. IV.

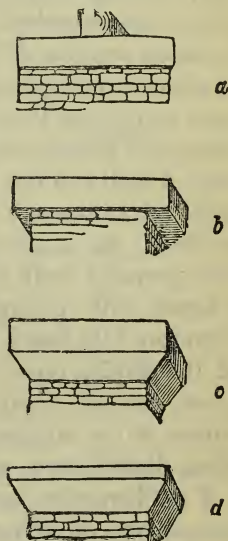

FIG. IV.

§ III. We must therefore have our flat stone in either case; and let *b*, Fig. IV., be the section or side of it, as it is set across the wall. Now, evidently, if by any chance this weight happen to be thrown more on the edges of this stone than the centre, there will be a chance of these edges breaking off. Had we not better, therefore, put another stone, sloped off to the wall, beneath the projecting one, as at *c*. But now our cornice looks somewhat too heavy for the wall; and as the upper stone is evidently of needless thickness, we will thin it somewhat, and we have the form *d*. Now observe: the lower or bevelled stone here at *d* corresponds to *d* in the base (Fig. II., page 66). That was the foot of the wall; this is its hand. And the top stone here, which is a constant member of cornices, corresponds to the under stone *c*, in Fig. II., which is a constant member of bases. The reader has no idea at present of the enormous importance of these members; but as we shall have to refer to them perpetually, I must ask him to compare them, and fix their relations well in his mind: and, for convenience, I shall call the bevelled or sloping stone, X, and the upright edged stone, Y. The reader may remember easily which is which; for X is an intersection of two slopes, and may therefore properly mean either of the two sloping stones; and Y is a figure with a perpendicular line and two slopes, and may therefore fitly stand for the upright stone in relation to each of the sloping ones; and as we shall have to say much more about cornices than about bases, let X and Y stand for the stones of the cornice, and Xb and Yb for those of the base, when distinction is needed.

§ IV. Now the form at *d*, Fig. IV., is the great root and primal type of all cornices whatsoever. In order to see what forms may be developed from it, let us take its profile a little larger—*a*, Fig. V., with X and Y duly marked. Now this form, being the root of all cornices, may either have to finish the wall and so keep off rain; or, as so often stated, to carry weight. If the former, it is evident that, in its present profile, the rain will run back down the slope of X; and if the latter, that the sharp angle or edge of X, at *k*, may be a little too weak for its work, and run a chance of giving way. To avoid

the evil in the first case, suppose we hollow the slope of X inwards, as at *b*; and to avoid it in the second case, suppose we strengthen X by letting it bulge outwards, as at *c*.

§ v. These (*b* and *c*) are the profiles of two vast families of cornices, springing from the same root, which, with a third arising from their combination (owing its origin to æsthetic considerations, and inclining sometimes to the one, sometimes to the other), have been employed, each on its third part of the architecture of the whole world throughout all ages, and must continue to be so employed through such time as is yet to come. We do not at present speak of the third or com-

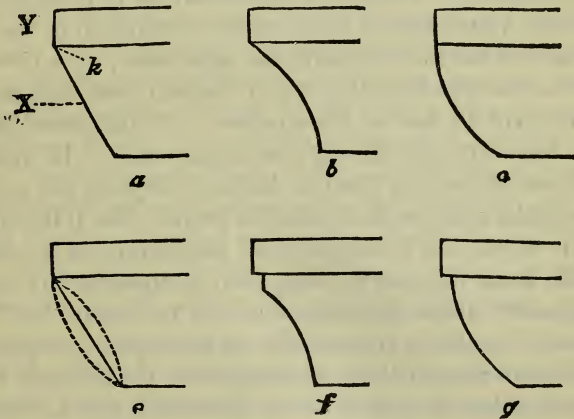

FIG. V.

bined group; but the relation of the two main branches to each other, and to the line of origin, is given at *e*, Fig. V.; where the dotted lines are the representatives of the two families, and the straight line of the root. The slope of this right line, as well as the nature of the curves, here drawn as segments of circles, we leave undetermined: the slope, as well as the proportion of the depths of X and Y to each other, vary according to the weight to be carried, the strength of the stone, the size of the cornice, and a thousand other accidents; and the nature of the curves according to æsthetic laws. It is in these infinite fields that the invention of the architect is

permitted to expatiate, but not in the alteration of primitive forms.

§ VI. But to proceed. It will doubtless appear to the reader, that, even allowing for some of these permissible variations in the curve or slope or X, neither the form at *b*, nor any approximation to that form, would be sufficiently undercut to keep the rain from running back upon it. This is true; but we have to consider that the cornice, as the close of the wall's life, is of all its features that which is best fitted for honor and ornament. It has been esteemed so by almost all builders, and has been lavishly decorated in modes hereafter to be considered. But it is evident that, as it is high above the eye, the fittest place to receive the decoration is the slope of X, which is inclined towards the spectator; and if we cut away or hollow out this slope more than we have done at *b*, all decoration will be hid in the shadow. If, therefore, the climate be fine, and rain of long continuance not to be dreaded, we shall not hollow the stone X further, adopting the curve at *b* merely as the most protective in our power. But if the climate be one in which rain is frequent and dangerous, as in alternations with frost, we may be compelled to consider the cornice in a character distinctly protective, and to hollow out X farther, so as to enable it thoroughly to accomplish its purpose. A cornice thus treated loses its character as the crown or honor of the wall, takes the office of its protector, and is called a DRIPSTONE. The dripstone is naturally the attribute of Northern buildings, and therefore especially of Gothic architecture; the true cornice is the attribute of Southern buildings, and therefore of Greek and Italian architecture; and it is one of their peculiar beauties, and eminent features of superiority.

§ VII. Before passing to the dripstone, however, let us examine a little farther into the nature of the true cornice. We cannot, indeed, render either of the forms *b* or *c*, Fig. V., perfectly protective from rain, but we can help them a little in their duty by a slight advance of their upper ledge. This, with the form *b*, we can best manage by cutting off the sharp upper point of its curve, which is evidently weak and useless;

and we shall have the form *f*. By a slight advance of the upper stone *c*, we shall have the parallel form *g*.

These two cornices, *f* and *g*, are characteristic of early Byzantine work, and are found on all the most lovely examples of it in Venice. The type *a* is rarer, but occurs pure in the most exquisite piece of composition in Venice—the northern portico of St. Mark's; and will be given in due time.

§ VIII. Now the reader has doubtless noticed that these forms of cornice result, from considerations of fitness and necessity, far more neatly and decisively than the forms of the base, which we left only very generally determined. The reason is, that there are many ways of building foundations, and many *good* ways, dependent upon the peculiar accidents of the ground and nature of accessible materials. There is also room to spare in width, and a chance of a part of the arrangement being concealed by the ground, so as to modify height. But we have no room to spare in width on the top of a wall, and all that we do must be thoroughly visible; and we can but have to deal with bricks, or stones of a certain degree of fineness, and not with mere gravel, or sand, or clay,—so that as the conditions are limited, the forms become determined; and our steps will be more clear and certain the farther we advance. The sources of a river are usually half lost among moss and pebbles, and its first movements doubtful in direction; but, as the current gathers force, its banks are determined, and its branches are numbered.

§ IX. So far of the true cornice: we have still to determine the form of the dripstone.

We go back to our primal type or root of cornice, *a* of Fig. V. We take this at *a* in Fig. VI., and we are to consider it entirely as a protection against rain. Now the only way in which the rain can be kept from running back on the slope of *X* is by a bold hollowing out of it upwards, *b*. But clearly, by thus doing, we shall so weaken the projecting part of it that the least shock would break it at the neck, *c*; we must therefore cut the whole out of one stone, which will give us the form *d*. That the water may not lodge on the upper

ledge of this, we had better round it off; and it will better protect the joint at the bottom of the slope if we let the stone project over it in a roll, cutting the recess deeper above. These two changes are made in *e*: *e* is the type of dripstones; the projecting part being, however, more or less rounded into an approximation to the shape of a falcon's beak, and often

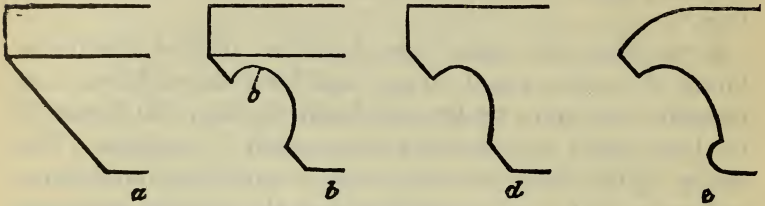

FIG. VI.

reaching it completely. But the essential part of the arrangement is the up and under cutting of the curve. Wherever we find this, we are sure that the climate is wet, or that the builders have been bred in a wet country, and that the rest of the building will be prepared for rough weather. The up cutting of the curve is sometimes all the distinction between the mouldings of far-distant countries and utterly strange nations.

Fig. VII. representing a moulding with an outer and inner curve, the latter under-cut. Take the outer line, and this moulding is one constant in Venice, in architecture traceable to Arabian types, and chiefly to the early mosques of Cairo. But take the inner line; it is a dripstone at Salisbury. In that narrow interval between the curves there is, when we read it rightly, an expression of another and mightier curve,—the orbed sweep of the earth and sea, between the desert of the Pyramids, and

the green and level fields through which the clear streams of Sarum wind so slowly.

And so delicate is the test, that though pure cornices are

often found in the north,—borrowed from classical models,—so surely as we find a true dripstone moulding in the South, the influence of Northern builders has been at work ; and this will be one of the principal evidences which I shall use in detecting Lombard influence on Arab work ; for the true Byzantine and Arab mouldings are all open to the sky and light, but the Lombards brought with them from the North the fear

of rain, and in all the Lombardic Gothic we instantly recognize the shadowy dripstone : *a*, Fig. VIII., is from a noble fragment at Milan, in the Piazza dei Mercanti ; *b*, from the Broletto of Como. Compare them with *c* and *d*, both from Salisbury ; *e* and *f*

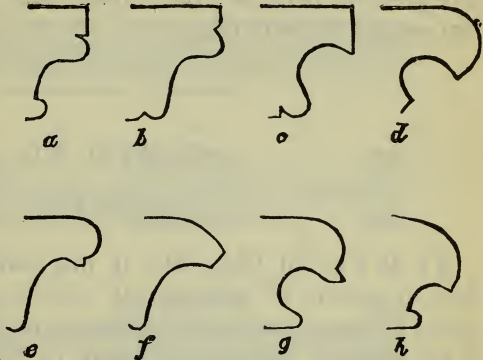

FIG. VIII.

from Lisieux, Normandy ; *g* and *h* from Wenlock Abbey, Shropshire.

§ x. The reader is now master of all that he need know about the construction of the general wall cornice, fitted either to become a crown of the wall, or to carry weight above. If, however, the weight above become considerable, it may be necessary to support the cornice at intervals with brackets ; especially if it be required to project far, as well as to carry weight ; as, for instance, if there be a gallery on top of the wall. This kind of bracket-cornice, deep or shallow, forms a separate family, essentially connected with roofs and galleries ; for if there be no superincumbent weight, it is evidently absurd to put brackets to a plain cornice or dripstone (though this is sometimes done in carrying out a style) ; so that, as soon as we see a bracket put to a cornice, it implies, or should imply, that there is a roof or gallery above it. Hence this family of cornices I shall consider in connection with roofing, calling them “roof cornices,” while what we

have hitherto examined are proper "wall cornices." The roof cornice and wall cornice are therefore treated in division D.

We are not, however, as yet nearly ready for our roof. We have only obtained that which was to be the object of our first division (A); we have got, that is to say, a general idea of a wall and of the three essential parts of a wall; and we have next, it will be remembered, to get an idea of a pier and the essential parts of a pier, which were to be the subjects of our second division (B).

CHAPTER VII.

THE PIER BASE.

§ I. IN § III. of Chap. III., it was stated that when a wall had to sustain an addition of vertical pressure, it was first fitted to sustain it by some addition to its own thickness; but if the pressure became very great, by being gathered up into PIERS.

I must first make the reader understand what I mean by a wall's being gathered up. Take a piece of tolerably thick drawing-paper, or thin Bristol board, five or six inches square. Set it on its edge on the table, and put a small octavo book on the edge or top of it, and it will bend instantly. Tear it into four strips all across, and roll up each strip tightly. Set these rolls on end on the table, and they will carry the small octavo perfectly well. Now the thickness or substance of the paper employed to carry the weight is exactly the same as it was before, only it is differently arranged, that is to say, "gathered up."* If therefore a wall be gathered up like the Bristol board, it will bear greater weight than it would if it

* The experiment is not quite fair in this rude fashion; for the small rolls owe their increase of strength much more to their tubular form than their aggregation of material; but if the paper be cut up into small strips, and tied together firmly in three or four compact bundles, it will exhibit increase of strength enough to show the principle. Vide, however, Appendix 16, "Strength of Shafts."

remained a wall veil. The sticks into which you gather it are called *Piers*. A pier is a coagulated wall.

§ II. Now you cannot quite treat the wall as you did the Bristol board, and twist it up at once ; but let us see how you can treat it. Let A, Fig. IX., be the plan of a wall which you have made inconveniently and expensively thick, and which still appears to be slightly too weak for what it must carry :

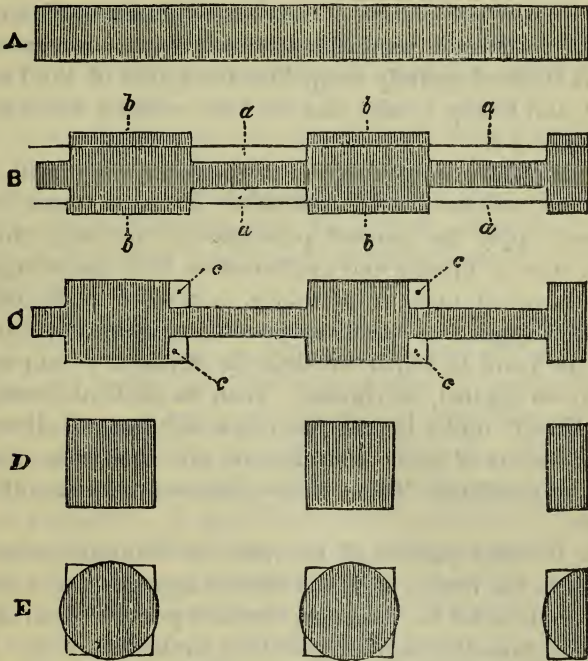

FIG. IX.

divide it, as at B, into equal spaces, *a*, *b*, *a*, *b*, &c. Cut out a thin slice of it at every *a* on each side, and put the slices you cut out on at every *b* on each side, and you will have the plan at B, with exactly the same quantity of bricks. But your wall is now so much concentrated, that, if it was only slightly too weak before, it will be stronger now than it need be ; so you may spare some of your space as well as your bricks by cut-

ting off the corners of the thicker parts, as suppose c, c, c, c at c : and you have now a series of square piers connected by a wall veil, which, on less space and with less materials, will do the work of the wall at A perfectly well.

§ III. I do not say *how much* may be cut away in the corners c, c ,—that is a mathematical question with which we need not trouble ourselves: all that we need know is, that out of every slice we take from the “ b 's” and put on at the “ a 's,” we may keep a certain percentage of room and bricks, until, supposing that we do not want the wall veil for its own sake, this latter is thinned entirely away, like the girdle of the Lady of Avenel, and finally breaks, and we have nothing but a row of square piers, D .

§ IV. But have we yet arrived at the form which will spare most room, and use fewest materials? No; and to get farther we must apply the general principle to our wall, which is equally true in morals and mathematics, that the strength of materials, or of men, or of minds, is always most available when it is applied as closely as possible to a single point.

Let the point to which we wish the strength of our square piers to be applied, be chosen. Then we shall of course put them directly under it, and the point will be in their centre. But now some of their materials are not so near or close to this point as others. Those at the corners are farther off than the rest.

Now, if every particle of the pier be brought as near as possible to the centre of it, the form it assumes is the circle.

The circle must be, therefore, the best possible form of plan for a pier, from the beginning of time to the end of it. A circular pier is called a pillar or column, and all good architecture adapted to vertical support is made up of pillars, has always been so, and must ever be so, as long as the laws of the universe hold.

The final condition is represented at E , in its relation to that at D . It will be observed that though each circle projects a little beyond the side of the square out of which it is formed, the space cut off at the angles is greater than that added at the sides; for, having our materials in a more concentrated

arrangement, we can afford to part with some of them in this last transformation, as in all the rest.

§ v. And now, what have the base and the cornice of the wall been doing while we have been cutting the veil to pieces and gathering it together?

The base is also cut to pieces, gathered together, and becomes the base of the column.

The cornice is cut to pieces, gathered together, and becomes the capital of the column. Do not be alarmed at the new word, it does not mean a new thing; a capital is only the cornice of a column, and you may, if you like, call a cornice the capital of a wall.

We have now, therefore, to examine these three concentrated forms of the base, veil, and cornice: first, the concentrated base, still called the *BASE* of the column; then the concentrated veil, called the *SHAFT* of the column; then the concentrated cornice, called the *CAPITAL* of the column.

And first the *Base*:—

§ vi. Look back to the main type, Fig. II., page 66, and apply its profiles in due proportion to the feet of the pillars at *E* in Fig. IX., p. 81: If each step in Fig. II. were gathered accurately, the projection of the entire circular base would be less in proportion to its height than it is in Fig. II.; but the approximation to the result in Fig. X. is quite accurate enough for our purposes. (I pray the reader to observe that I have not made the smallest change, except this necessary expression of a reduction in diameter, in Fig. II. as it is applied in Fig. X., only I have not drawn the joints of the stones because these would confuse the outlines of the bases; and I have not represented the rounding of the shafts, because it does not bear at present on the argument.) Now it would hardly be convenient, if we had to pass between the pillars, to have to squeeze ourselves through one of those angular gaps or brèches de Roland in Fig. X. Our first impulse would be to cut them open; but we cannot do this, or our piers are unsafe. We have but one other resource, to fill them up until we have a floor wide enough to let us pass easily: this we may perhaps obtain at the first ledge, we are nearly sure to get it at the

second, and we may then obtain access to the raised interval, either by raising the earth over the lower courses of foundation, or by steps round the entire building.

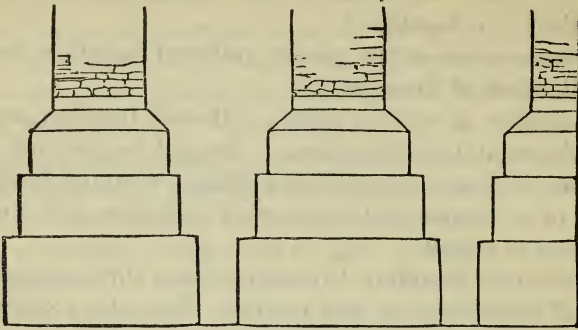

FIG. X.

Fig. XI. is the arrangement of Fig. X. so treated.

§ VII. But suppose the pillars are so vast that the lowest chink in Fig. X. would be quite wide enough to let us pass through it. Is there then any reason for filling it up? Yes. It will be remembered that in Chap. IV. § VIII. the chief reason

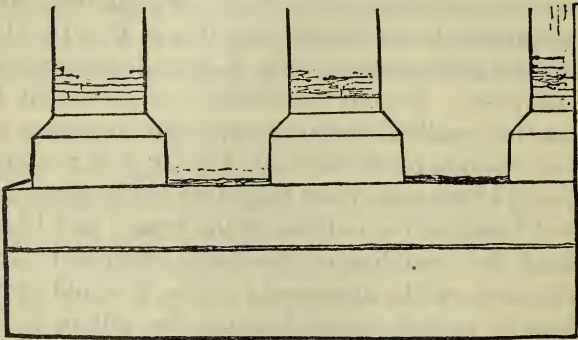

FIG. XI.

for the wide foundation of the wall was stated to be "that it might equalise its pressure over a large surface;" but when the foundation is cut to pieces as in Fig. X., the pressure is thrown on a succession of narrowed and detached spaces of

that surface. If the ground is in some places more disposed to yield than in others, the piers in those places will sink more than the rest, and this distortion of the system will be probably of more importance in pillars than in a wall, because the adjustment of the weight above is more delicate ; we thus actually want the *weight* of the stones between the pillars, in order that the whole foundation may be bonded into one, and sink together if it sink at all : and the more massy the pillars, the more we shall need to fill the intervals of their foundations. In the best form of Greek architecture, the intervals are filled up to the root of the shaft, and the columns have no independent base ; they stand on the even floor of their foundation.

§ viii. Such a structure is not only admissible, but, when the column is of great thickness in proportion to its height, and the sufficient firmness, either of the ground or prepared floor, is evident, it is the best of all, having a strange dignity in its excessive simplicity. It is, or ought to be, connected in our minds with the deep meaning of primeval memorial. "And Jacob took the stone that he had put for his pillow, and set it up for a pillar." I do not fancy that he put a base for it first. If you try to put a base to the rock-piers of Stonehenge, you will hardly find them improved ; and two of the most perfect buildings in the world, the Parthenon and Ducal palace of Venice, have no bases to their pillars : the latter has them, indeed, to its upper arcade shafts ; and had once, it is said, a continuous raised base for its lower ones : but successive elevations of St. Mark's Place have covered this base, and parts of the shafts themselves, with an inundation of paving stones ; and yet the building is, I doubt not, as grand as ever. Finally, the two most noble pillars in Venice, those brought from Acre, stand on the smooth marble surface of the Piazzetta, with no independent bases whatever. They are rather broken away beneath, so that you may look under parts of them, and stand (not quite erect, but leaning somewhat) safe by their own massy weight. Nor could any basis possibly be devised that would not spoil them.

§ ix. But it is otherwise if the pillar be so slender as to

look doubtfully balanced. It would indeed stand quite as safely without an independent base as it would with one (at least, unless the base be in the form of a socket). But it will not appear so safe to the eye. And here for the first time, I have to express and apply a principle, which I believe the reader will at once grant,—that features necessary to express security to the imagination, are often as essential parts of good architecture as those required for security itself. It was said that the wall base was the foot or paw of the wall. Exactly in the same way, and with clearer analogy, the pier base is the foot or paw of the pier. Let us, then, take a hint from nature. A foot has two offices, to bear up, and to hold firm. As far as it has to bear up, it is uncloven, with slight projection,—look at an elephant's (the Doric base of animality);* but as far as it has to hold firm, it is divided and clawed, with wide projections,—look at an eagle's.

§ x. Now observe. In proportion to the massiness of the column, we require its foot to express merely the power of bearing up; in fact, it can do without a foot, like the Squire in Chevy Chase, if the ground only be hard enough. But if the column be slender, and look as if it might lose its balance, we require it to look as if it had hold of the ground, or the ground hold of it, it does not matter which,—some expression of claw, prop, or socket. Now let us go back to Fig. XI., and take up one of the bases there, in the state in which we left it. We may leave out the two lower steps (with which we have nothing more to do, as they have become the united floor or foundation of the whole), and, for the sake of greater clearness, I shall not draw the bricks in the shaft, nor the flat stone which carries them, though the reader is to suppose them remaining as drawn in Fig. XI.; but I shall only draw the shaft and its two essential members of base, Xb and Yb, as explained at p. 74, above: and now, expressing the rounding of these numbers on a somewhat larger scale, we have the profile *a*, Fig. XII.; *b*, the perspective appearance of such a base seen from above; and *c*, the plan of it.

§ xi. Now I am quite sure the reader is not satisfied of the

* Appendix 17, "Answer to Mr. Garbett."

stability of this form as it is seen at *b*; nor would he ever be so with the main contour of a circular base. Observe, we have taken some trouble to reduce the member *Yb* into this round form, and all that we have gained by so doing, is this unsatisfactory and unstable look of the base; of which the chief reason is, that a circle, unless enclosed by right lines, has never an appearance of fixture, or definite place, *—we suspect it of motion, like an orb of heaven; and the second is, that the

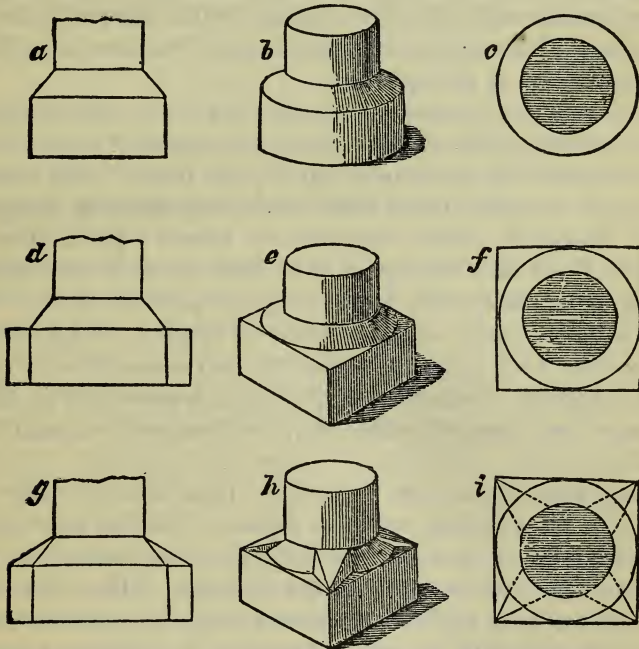

FIG. XII.

whole base, considered as the foot of the shaft, has no grasp nor hold: it is a club-foot, and looks too blunt for the limb,—it wants at least expansion, if not division.

§ XII. Suppose, then, instead of taking so much trouble

* Yet more so than any other figure enclosed by a curved line: for the circle, in its relations to its own centre, is the curve of greatest stability. Compare § XX. of Chap. XX.

with the member Yb, we save time and labor, and leave it a square block. Xb must, however, evidently follow the pillar, as its condition is that it slope to the very base of the wall veil, and of whatever the wall veil becomes. So the corners of Yb will project beyond the circle of Xb, and we shall have (Fig. XII.) the profile *d*, the perspective appearance *e*, and the plan *f*. I am quite sure the reader likes *e* much better than he did *b*. The circle is now placed, and we are not afraid of its rolling away. The foot has greater expansion, and we have saved labor besides, with little loss of space, for the interval between the bases is just as great as it was before,—we have only filled up the corners of the squares.

But is it not possible to mend the form still further? There is surely still an appearance of separation between Xb and Yb, as if the one might slip off the other. The foot is expanded enough; but it needs some expression of grasp as well. It has no toes. Suppose we were to put a spur or prop to Xb at each corner, so as to hold it fast in the centre of Yb. We will do this in the simplest possible form. We will have the spur, or small buttress, sloping straight from the corner of Yb up to the top of Xb, and as seen from above, of the shape of a triangle. Applying such spurs in Fig. XII., we have the diagonal profile at *g*, the perspective *h*, and the plan *i*.

§ XIII. I am quite sure the reader likes this last base the best, and feels as if it were the firmest. But he must carefully distinguish between this feeling or imagination of the eye, and the real stability of the structure. That this real stability has been slightly increased by the changes between *b* and *h*, in Fig. XII., is true. There is in the base *h* somewhat less chance of accidental dislocation, and somewhat greater solidity and weight. But this very slight gain of security is of no importance whatever when compared with the general requirements of the structure. The pillar must be *perfectly* secure, and more than secure, with the base *b*, or the building will be unsafe, whatever other base you put to the pillar. The changes are made, not for the sake of the almost inappreciable increase of security they involve, but in order

to convince the eye of the real security which the base *b* appears to compromise. This is especially the case with regard to the props or spurs, which are absolutely useless in reality, but are of the highest importance as an expression of safety. And this will farther appear when we observe that they have been above quite arbitrarily supposed to be of a triangular form. Why triangular? Why should not the spur be made wider and stronger, so as to occupy the whole width of the angle of the square, and to become a complete expansion of Xb to the edge of the square? Simply because, whatever its width, it has, in reality, no supporting power whatever; and the *expression* of support is greatest where it assumes a form approximating to that of the spur or claw of an animal. We shall, however, find hereafter, that it ought indeed to be much wider than it is in Fig. XII., where it is narrowed in order to make its structure clearly intelligible.

§ xiv. If the reader chooses to consider this spur as an aesthetic feature altogether, he is at liberty to do so, and to transfer what we have here said of it to the beginning of Chap. XXV. I think that its true place is here, as an *expression* of safety, and not a means of beauty; but I will assume only, as established, the form *e* of Fig. XII., which is absolutely, as a construction, easier, stronger, and more perfect than *b*. A word or two now of its materials. The wall base, it will be remembered, was built of stones more neatly cut as they were higher in place; and the members, Y and X, of the pier base, were the highest members of the wall base gathered. But, exactly in proportion to this gathering or concentration in form, should, if possible, be the gathering or concentration of substance. For as the whole weight of the building is now to rest upon few and limited spaces, it is of the greater importance that it should be there received by solid masonry. Xb and Yb are therefore, if possible, to be each of a single stone; or, when the shaft is small, both cut out of one block, and especially if spurs are to be added to Xb. The reader must not be angry with me for stating things so self-evident, for these are all necessary steps in the chain of argument which I must not break. Even this change

from detached stones to a single block is not without significance; for it is part of the real service and value of the member Yb to provide for the reception of the shaft a surface free from joints; and the eye always conceives it as a firm covering over all inequalities or fissures in the smaller masonry of the floor.

§ XV. I have said nothing yet of the proportion of the height of Yb to its width, nor of that of Yb and Xb to each other. Both depend much on the height of shaft, and are besides variable within certain limits, at the architect's discretion. But the limits of the height of Yb may be thus generally stated. If it looks so thin as that the weight of the column above might break it, it is too low; and if it is higher than its own width, it is too high. The utmost admissible height is that of a cubic block; for if it ever become higher than it is wide, it becomes itself a part of a pier, and not the base of one.

§ XVI. I have also supposed Yb, when expanded from beneath Xb, as always expanded into a square, and four spurs only to be added at the angles. But Yb may be expanded into a pentagon, hexagon, or polygon; and Xb then may have five, six, or many spurs. In proportion, however, as the sides increase in number, the spurs become shorter and less energetic in their effect, and the square is in most cases the best form.

§ XVII. We have hitherto conducted the argument entirely on the supposition of the pillars being numerous, and in a range. Suppose, however, that we require only a single pillar: as we have free space round it, there is no need to fill up the first ranges of its foundations; nor need we do so in order to equalise pressure, since the pressure to be met is its own alone. Under such circumstances, it is well to exhibit the lower tiers of the foundation as well as Yb and Xb. The noble bases of the two granite pillars of the Piazzetta at Venice are formed by the entire series of members given in Fig. X., the lower courses expanding into steps, with a superb breadth of proportion to the shaft. The member Xb is of course circular, having its proper decorative mouldings, not

here considered ; Yb is octagonal, but filled up into a square by certain curious groups of figures representing the trades of Venice. The three courses below are octagonal, with their sides set across the angles of the innermost octagon, Yb. The shafts are 15 feet in circumference, and the lowest octagons of the base 56 (7 feet each side).

§ xviii. Detached buildings, like our own Monument, are not pillars, but towers built in imitation of Pillars. As towers they are barbarous, being dark, inconvenient, and unsafe, besides lying, and pretending to be what they are not. As shafts they are barbarous, because they were designed at a time when the Renaissance architects had introduced and forced into acceptance, as *de rigueur*, a kind of columnar high-heeled shoe,—a thing which they called a pedestal, and which is to a true base exactly what a Greek actor's cothurnus was to a Greek gentleman's sandal. But the Greek actor knew better, I believe, than to exhibit or to decorate his cork sole ; and, with shafts as with heroes, it is rather better to put the sandal off than the cothurnus on. There are, indeed, occasions on which a pedestal may be necessary ; it may be better to raise a shaft from a sudden depression of plinth to a level with others, its companions, by means of a pedestal, than to introduce a higher shaft ; or it may be better to place a shaft of alabaster, if otherwise too short for our purpose, on a pedestal, than to use a larger shaft of coarser material ; but the pedestal is in each case a make-shift, not an additional perfection. It may, in the like manner, be sometimes convenient for men to walk on stilts, but not to keep their stilts on as ornamental parts of dress. The bases of the Nelson Column, the Monument, and the column of the Place Vendôme, are to the shafts, exactly what highly ornamented wooden legs would be to human beings.

§ xix. So far of bases of detached shafts. As we do not yet know in what manner shafts are likely to be grouped, we can say nothing of those of grouped shafts until we know more of what they are to support.

Lastly ; we have throughout our reasoning upon the base supposed the pier to be circular. But circumstances may

occur to prevent its being reduced to this form, and it may remain square or rectangular; its base will then be simply the wall base following its contour, and we have no spurs at the angles. Thus much may serve respecting pier bases; we have next to examine the concentration of the Wall Veil, or the Shaft.

CHAPTER VIII.

THE SHAFT.

§ I. WE have seen in the last Chapter how, in converting the wall into the square or cylindrical shaft, we parted at every change of form with some quantity of material. In proportion to the quantity thus surrendered, is the necessity that what we retain should be good of its kind, and well set together, since everything now depends on it.

It is clear also that the best material, and the closest concentration, is that of the natural crystalline rocks; and that, by having reduced our wall into the shape of shafts, we may be enabled to avail ourselves of this better material, and to exchange cemented bricks for crystallised blocks of stone. Therefore, the general idea of a perfect shaft is that of a single stone hewn into a form more or less elongated and cylindrical. Under this form, or at least under the ruder one of a long stone set upright, the conception of true shafts appears first to have occurred to the human mind; for the reader must note this carefully, once for all, it does not in the least follow that the order of architectural features which is most reasonable in their arrangement, is most probable in their invention. I have theoretically deduced shafts from walls, but shafts were never so reasoned out in architectural practice. The man who first propped a thatched roof with poles was the discoverer of their principle; and he who first hewed a long stone into a cylinder, the perfecter of their practice.

§ II. It is clearly necessary that shafts of this kind (we will call them, for convenience, *block shafts*) should be composed

of stone not liable to flaws or fissures ; and therefore that we must no longer continue our argument as if it were always possible to do what is to be done in the best way ; for the style of a national architecture may evidently depend, in great measure upon the nature of the rocks of the country.

Our own English rocks, which supply excellent building stone from their thin and easily divisible beds, are for the most part entirely incapable of being worked into shafts of any size, except only the granites and whinstones, whose hardness renders them intractable for ordinary purposes ;—and English architecture therefore supplies no instances of the block shaft applied on an extensive scale ; while the facility of obtaining large masses of marble has in Greece and Italy been partly the cause of the adoption of certain noble types of architectural form peculiar to those countries, or, when occurring elsewhere, derived from them.

We have not, however, in reducing our walls to shafts, calculated on the probabilities of our obtaining better materials than those of which the walls were built ; and we shall therefore first consider the form of shaft which will be best when we have the best materials ; and then consider how far we can imitate, or how far it will be wise to imitate, this form with any materials we can obtain.

§ III. Now as I gave the reader the ground, and the stones, that he might for himself find out how to build his wall, I shall give him the block of marble, and the chisel, that he may himself find out how to shape his column. Let him suppose the elongated mass, so given him, rudely hewn to the thickness which he has calculated will be proportioned to the weight it has to carry. The conditions of stability will require that some allowance be made in finishing it for any chance of slight disturbance or subsidence of the ground below, and that, as everything must depend on the uprightness of the shaft, as little chance should be left as possible of its being thrown off its balance. It will therefore be prudent to leave it slightly thicker at the base than at the top. This excess of diameter at the base being determined, the reader is to ask himself how most easily and simply to smooth the column from one extrem-

ity to the other. To cut it into a true straight-sided cone would be a matter of much trouble and nicety, and would incur the continual risk of chipping into it too deep. Why not leave some room for a chance stroke, work it slightly, *very* slightly convex, and smooth the curve by the eye between the two extremities? you will save much trouble and time, and the shaft will be all the stronger.

This is accordingly the natural form of a detached block shaft. It is the best. No other will ever be so agreeable to the mind or eye. I do not mean that it is not capable of more refined execution, or of the application of some of the

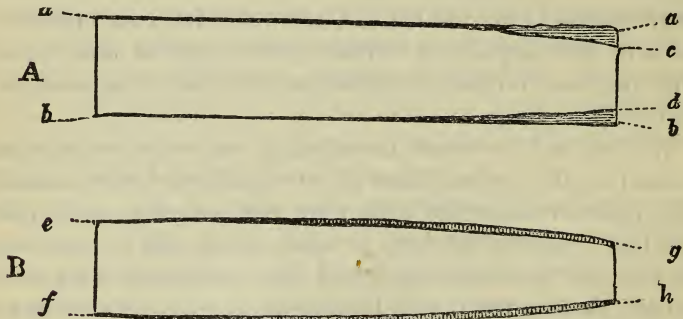

FIG. XIII.

laws of æsthetic beauty, but that it is the best recipient of execution and subject of law; better in either case than if you had taken more pains, and cut it straight.

§ IV. You will observe, however, that the convexity is to be very slight, and that the shaft is not to *bulge* in the centre, but to taper from the root in a curved line; the peculiar character of the curve you will discern better by exaggerating, in a diagram, the conditions of its sculpture.

Let *a, a, b, b*, at A, Fig. XIII., be the rough block of the shaft, laid on the ground; and as thick as you can by any chance require it to be; you will leave it of this full thickness at its base at A, but at the other end you will mark off upon it the diameter *c, d*, which you intend it to have at the summit; you will then take your mallet and chisel, and working from *c*

and *d* you will roughly knock off the corners shaded in the figure, so as to reduce the shaft to the figure described by the inside lines in *A* and the outside lines in *B*; you then proceed to smooth it, you chisel away the shaded parts in *B*, and leave your finished shaft of the form of the *inside* lines *e, g, f, h*.

The result of this operation will be of course that the shaft tapers faster towards the top than it does near the ground. Observe this carefully; it is a point of great future importance.

§ v. So far of the shape of detached or block shafts. We can carry the type no farther on merely structural considerations: let us pass to the shaft of inferior materials.

Unfortunately, in practice, this step must be soon made. It is alike difficult to obtain, transport, and raise, block shafts more than ten or twelve feet long, except in remarkable positions, and as pieces of singular magnificence. Large pillars are therefore always composed of more than one block of stone. Such pillars are either jointed like basalt columns, and composed of solid pieces of stone set one above another; or they are filled up *towers*, built of small stones cemented into a mass, with more or less of regularity: Keep this distinction carefully in mind, it is of great importance; for the jointed column, every stone composing which, however thin, is (so to speak) a complete *slice* of the shaft, is just as strong as the block pillar of one stone, so long as no forces are brought into action upon it which would have a tendency to cause horizontal dislocation. But the pillar which is built as a filled-up tower is of course liable to fissure in any direction, if its cement give way.

But, in either case, it is evident that all constructive reason of the curved contour is at once destroyed. Far from being an easy or natural procedure, the fitting of each portion of the curve to its fellow, in the separate stones, would require painful care and considerable masonic skill; while, in the case of the filled-up tower, the curve outwards would be even unsafe; for its greatest strength (and that the more in proportion to its careless building) lies in its bark, or shell of outside stone; and this, if curved outwards, would at once burst outwards, if heavily loaded above.

If, therefore, the curved outline be ever retained in such shafts, it must be in obedience to æsthetic laws only.

§ VI. But farther. Not only the curvature, but even the tapering by straight lines, would be somewhat difficult of execution in the pieced column. Where, indeed, the entire shaft is composed of four or five blocks set one upon another, the diameters may be easily determined at the successive joints, and the stones chiselled to the same slope. But this becomes sufficiently troublesome when the joints are numerous, so that the pillar is like a pile of cheeses; or when it is to be built of small and irregular stones. We should be naturally led, in the one case, to cut all the cheeses to the same diameter; in the other to build by the plumb-line; and in both to give up the tapering altogether.

§ VII. Farther. Since the chance, in the one case, of horizontal dislocation, in the other, of irregular fissure, is much increased by the composition of the shaft out of joints or small stones, a larger bulk of shaft is required to carry the given weight; and, *cæteris paribus*, jointed and cemented shafts must be thicker in proportion to the weight they carry than those which are of one block.

We have here evidently natural causes of a very marked division in schools of architecture: one group composed of buildings whose shafts are either of a single stone or of few joints; the shafts, therefore, being gracefully tapered, and reduced by successive experiments to the narrowest possible diameter proportioned to the weight they carry: and the other group embracing those buildings whose shafts are of many joints or of small stones; shafts which are therefore not tapered, and rather thick and ponderous in proportion to the weight they carry; the latter school being evidently somewhat imperfect and inelegant as compared with the former.

It may perhaps appear, also, that this arrangement of the materials in cylindrical shafts at all would hardly have suggested itself to a people who possessed no large blocks out of which to hew them; and that the shaft built of many pieces is probably derived from, and imitative of the shaft hewn from few or from one.

§ VIII. If, therefore, you take a good geological map of Europe, and lay your finger upon the spots where volcanic influences supply either travertin or marble in accessible and available masses, you will probably mark the points where the types of the first school have been originated and developed. If, in the next place, you will mark the districts where broken and rugged basalt or whinstone, or slaty sandstone, supply materials on easier terms indeed, but fragmentary and unmanageable, you will probably distinguish some of the birthplaces of the derivative and less graceful school. You will, in the first case, lay your finger on Pæstum, Agrigentum, and Athens; in the second, on Durham and Lindisfarne.

The shafts of the great primal school are, indeed, in their first form, as massy as those of the other, and the tendency of both is to continual diminution of their diameters: but in the first school it is a true diminution in the thickness of the independent pier; in the last, it is an apparent diminution, obtained by giving it the appearance of a group of minor piers. The distinction, however, with which we are concerned is not that of slenderness, but of vertical or curved contour; and we may note generally that while throughout the whole range of Northern work, the perpendicular shaft appears in continually clearer development, throughout every group which has inherited the spirit of the Greek, the shaft retains its curved or tapered form; and the occurrence of the vertical detached shaft may at all times, in European architecture, be regarded as one of the most important collateral evidences of Northern influence.

§ IX. It is necessary to limit this observation to European architecture, because the Egyptian shaft is often untapered, like the Northern. It appears that the Central Southern, or Greek shaft, was tapered or curved on æsthetic rather than constructive principles; and the Egyptian which precedes, and the Northern which follows it, are both vertical, the one because the best form had not been discovered, the other because it could not be attained. Both are in a certain degree barbaric; and both possess in combination and in their ornaments a power altogether different from that of the Greek shaft, and at least as impressive if not as admirable.

§ x. We have hitherto spoken of shafts as if their number were fixed, and only their diameter variable according to the weight to be borne. But this supposition is evidently gratuitous; for the same weight may be carried either by many and slender, or by few and massy shafts. If the reader will look back to Fig. IX., he will find the number of shafts into which the wall was reduced to be dependent altogether upon the length of the spaces *a, b, a, b, &c.*, a length which was arbitrarily fixed. We are at liberty to make these spaces of what length we choose, and, in so doing, to increase the number and diminish the diameter of the shafts, or *vice versâ*.

§ xi. Supposing the materials are in each case to be of the same kind, the choice is in great part at the architect's discretion, only there is a limit on the one hand to the multiplication of the slender shaft, in the inconvenience of the narrowed interval, and on the other, to the enlargement of the massy shaft, in the loss of breadth to the building.* That will be commonly the best proportion which is a natural mean between the two limits; leaning to the side of grace or of grandeur according to the expressional intention of the work. I say, *commonly* the best, because, in some cases, this expressional invention may prevail over all other considerations, and a column of unnecessary bulk or fantastic slightness be adopted in order to strike the spectator with awe or with surprise.† The architect is, however, rarely in practice compelled to use one kind of material only; and his choice lies frequently between the employment of a larger number of solid and perfect small shafts, or a less number of pieced and cemented large ones. It is often possible to obtain from quarries near at hand, blocks which might be cut into shafts eight or twelve feet

* In saying this, it is assumed that the interval is one which is to be traversed by men; and that a certain relation of the shafts and intervals to the size of the human figure is therefore necessary. When shafts are used in the upper stories of buildings, or on a scale which ignores all relation to the human figure, no such relative limits exist either to slenderness or solidity.

† Vide the interesting discussion of this point in Mr. Fergusson's account of the Temple of Karnak, "Principles of Beauty in Art," p. 219.

long and four or five feet round, when larger shafts can only be obtained in distant localities ; and the question then is between the perfection of smaller features and the imperfection of larger. We shall find numberless instances in Italy in which the first choice has been boldly, and I think most wisely made ; and magnificent buildings have been composed of systems of small but perfect shafts, multiplied and superimposed. So long as the idea of the symmetry of a perfect shaft remained in the builder's mind, his choice could hardly be directed otherwise, and the adoption of the built and tower-like shaft appears to have been the result of a loss of this sense of symmetry consequent on the employment of intractable materials.

§ XII. But farther : we have up to this point spoken of shafts as always set in ranges, and at equal intervals from each other. But there is no necessity for this ; and material differences may be made in their diameters if two or more be grouped so as to do together the work of one large one, and that within, or nearly within, the space which the larger one would have occupied.

§ XIII. Let A, B, C , Fig. XIV., be three surfaces, of which B and C contain equal areas, and each of them double that of A : then supposing them all loaded to the same height, B or C would receive twice as much weight as A ; therefore, to carry B or C loaded, we should need a shaft of twice the strength needed to carry A . Let s be the shaft required to carry A , and s_2 the shaft required to carry B or C ; then s may be divided into two shafts, or s_2 into four shafts, as at s_3 , all equal in area or solid contents ;* and the mass A might be carried safely by two of them, and the masses B and C , each by four of them.

Now if we put the single shafts each under the centre of the mass they have to bear, as represented by the shaded circles at a, a_2, a_3 , the masses A and C are both of them very ill supported, and even B insufficiently ; but apply the four and

* I have assumed that the strength of similar shafts of equal height is as the squares of their diameters ; which, though not actually a correct expression, is sufficiently so for all our present purposes.

the two shafts as at b , b_2 , b_3 , and they are supported satisfactorily. Let the weight on each of the masses be doubled, and the shafts doubled in area, then we shall have such arrangements as those at c , c_2 , c_3 ; and if again the shafts and weight be doubled, we shall have d , d_2 , d_3 .

§ XIV. Now it will at once be observed that the arrangement of the shafts in the series of b and c is always exactly the same in their relations to each other; only the group of b is set evenly, and the group of c is set obliquely,—the one carrying a square, the other a cross.

You have in these two series the primal representations of shaft arrangement in the Southern and Northern schools; while the group b , of which b_2 is the double, set evenly, and c_2 the double, set obliquely, is common to both.

The reader will be surprised to find how all the complex and varied forms of shaft arrangement will

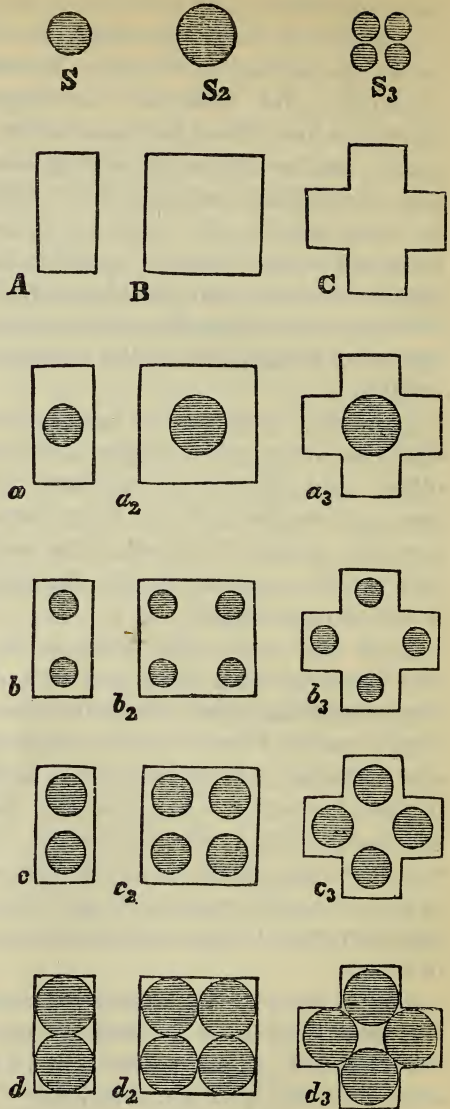

FIG. XIV.

range themselves into one or other of these groups; and still more surprised to find the oblique or cross set system on the one hand, and the square set system on the other, severally distinctive of Southern and Northern work. The dome of St. Mark's, and the crossing of the nave and transepts of Beauvais, are both carried by square piers; but the piers of St. Mark's are set square to the walls of the church, and those of Beauvais obliquely to them: and this difference is even a more essential one than that between the smooth surface of the one and the reedy complication of the other. The two squares here in the margin (Fig. XV.) are exactly of the same size, but their expression is altogether different, and in that difference lies one of the most subtle distinctions between the Gothic and Greek spirit, — from the shaft, which bears the building, to the smallest decoration.

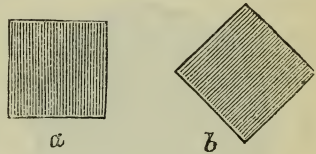

FIG. XV.

The Greek square is by preference set evenly, the Gothic square obliquely; and that so constantly, that wherever we find the level or even square occurring as a prevailing form, either in plan or decoration, in early northern work, there we may at least suspect the presence of a southern or Greek influence; and, on the other hand, wherever the oblique square is prominent in the south, we may confidently look for farther evidence of the influence of the Gothic architects. The rule must not of course be pressed far when, in either school, there has been determined search for every possible variety of decorative figures; and accidental circumstances may reverse the usual system in special cases; but the evidence drawn from this character is collaterally of the highest value, and the tracing it out is a pursuit of singular interest. Thus, the Pisan Romanesque might in an instant be pronounced to have been formed under some measure of Lombardic influence, from the oblique squares set under its arches; and in it we have the spirit of northern Gothic affecting details of the southern; — obliquity of square, in magnificently shafted Romanesque. At Monza, on the other hand, the levelled square is the char-

acteristic figure of the entire decoration of the façade of the Duomo, eminently giving it southern character; but the details are derived almost entirely from the northern Gothic. Here then we have southern spirit and northern detail. Of the cruciform outline of the load of the shaft, a still more positive test of northern work, we shall have more to say in the 28th Chapter; we must at present note certain farther changes in the form of the grouped shaft, which open the way to every branch of its endless combinations, southern or northern.

§ xv. 1. If the group at *d*, Fig. XIV., be taken from under

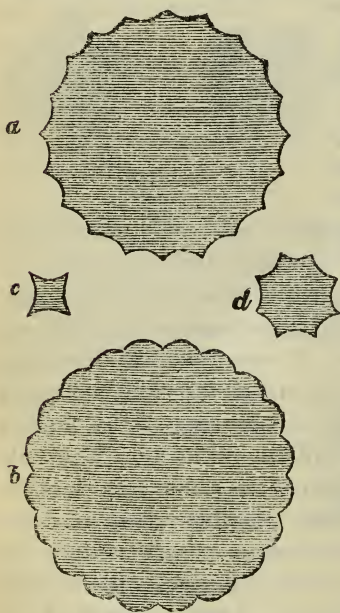

FIG. XVI.

its loading, and have its centre filled up, it will become a quatrefoil; and it will represent, in their form of most frequent occurrence, a family of shafts, whose plans are foiled figures, trefoils, quatrefoils, cinquefoils, &c.; of which a trefoiled example, from the Frari at Venice, is the third in Plate II., and a quatrefoil from Salisbury the eighth. It is rare, however, to find in Gothic architecture shafts of this family composed of a large number of foils, because multifoiled shafts are seldom true grouped shafts, but are rather canaliculated conditions of massy piers. The representatives of this family may be considered as the quatrefoil on the Gothic

side of the Alps; and the Egyptian multifoiled shaft on the south, approximating to the general type, *b*, Fig. XVI.

§ xvi. Exactly opposed to this great family is that of shafts which have concave curves instead of convex on each of their sides; but these are not, properly speaking, grouped shafts at all, and their proper place is among decorated piers; only

they must be named here in order to mark their exact opposition to the foiled system. In their simplest form, represented by *c*, Fig. XVI., they have no representatives in good architecture, being evidently weak and meagre; but approximations to them exist in late Gothic, as in the vile cathedral of Orleans, and in modern cast-iron shafts. In their fully developed form they are the Greek Doric, *a*, Fig. XVI., and occur in caprices of the Romanesque and Italian Gothic: *d*, Fig. XVI., is from the Duomo of Monza.

§ XVII. 2. Between c_3 and d_3 of Fig. XIV. there may be evidently another condition, represented at 6, Plate II., and formed by the insertion of a central shaft within the four external ones. This central shaft we may suppose to expand in proportion to the weight it has to carry. If the external shafts expand in the same proportion, the entire form remains unchanged; but if they do not expand, they may (1) be pushed out by the expanding shaft, or (2) be gradually swallowed up in its expansion, as at 4, Plate II. If they are pushed out, they are removed farther from each other by every increase of the central shaft; and others may then be introduced in the vacant spaces; giving, on the plan, a central orb with an ever increasing host of satellites, 10, Plate II.; the satellites themselves often varying in size, and perhaps quitting contact with the central shaft. Suppose them in any of their conditions fixed, while the inner shaft expands, and they will be gradually buried in it, forming more complicated conditions of 4, Plate II. The combinations are thus altogether infinite, even supposing the central shaft to be circular only; but their infinity is multiplied by many other infinities when the central shaft itself becomes square or crosslet on the section, or itself multifoiled (8, Plate II.) with satellite shafts eddying about its recesses and angles, in every possible relation of attraction. Among these endless conditions of change, the choice of the architect is free, this only being generally noted: that, as the whole value of such piers depends, first, upon their being wisely fitted to the weight above them, and, secondly, upon their all working together and one not failing the rest, perhaps to the ruin of all, he

must never multiply shafts without visible cause in the disposition of members superimposed :* and in his multiplied group he should, if possible, avoid a marked separation between the large central shaft and its satellites ; for if this exist, the satellites will either appear useless altogether, or else, which is worse, they will look as if they were meant to keep the central shaft together by wiring or caging it in ; like iron rods set round a supple cylinder,—a fatal fault in the piers of Westminster Abbey, and, in a less degree, in the noble nave of the cathedral of Bourges.

§ XVIII. While, however, we have been thus subdividing or assembling our shafts, how far has it been possible to retain their curved or tapered outline ? So long as they remain distinct and equal, however close to each other, the independent curvature may evidently be retained. But when once they come in contact, it is equally evident that a column, formed of shafts touching at the base and separate at the top, would appear as if in the very act of splitting asunder. Hence, in all the closely arranged groups, and especially those with a central shaft, the tapering is sacrificed ; and with less cause for regret, because it was a provision against subsidence or distortion, which cannot now take place with the separate members of the group. Evidently, the work, if safe at all, must be executed with far greater accuracy and stability when its supports are so delicately arranged, than would be implied by such precaution. In grouping shafts, therefore, a true perpendicular line is, in nearly all cases, given to the pier ; and the reader will anticipate that the two schools, which we have already found to be distinguished, the one by its perpendicular and pieced shafts, and the other by its curved and block shafts, will be found divided also in their employment of grouped shafts ;—it is likely that the idea of grouping, however suggested, will be fully entertained and acted upon by the one, but hesitatingly by the other ; and that we shall find, on the one hand, buildings displaying sometimes massy piers

* How far this condition limits the system of shaft grouping we shall see presently. The reader must remember, that we at present reason respecting shafts in the abstract only.

of small stones, sometimes clustered piers of rich complexity, and on the other, more or less regular succession of block shafts, each treated as entirely independent of those around it.

§ XIX. Farther, the grouping of shafts once admitted, it is probable that the complexity and richness of such arrangements would recommend them to the eye, and induce their frequent, even their unnecessary introduction ; so that weight which might have been borne by a single pillar, would be in preference supported by four or five. And if the stone of the country, whose fragmentary character first occasioned the building and piecing of the large pier, were yet in beds consistent enough to supply shafts of very small diameter, the strength and simplicity of such a construction might justify it, as well as its grace. The fact, however, is that the charm which the multiplication of line possesses for the eye has always been one of the chief ends of the work in the grouped schools ; and that, so far from employing the grouped piers in order to the introduction of very slender block shafts, the most common form in which such piers occur is that of a solid jointed shaft, each joint being separately cut into the contour of the group required.

§ XX. We have hitherto supposed that all grouped or clustered shafts have been the result or the expression of an actual gathering and binding together of detached shafts. This is not, however, always so : for some clustered shafts are little more than solid piers channelled on the surface, and their form appears to be merely the development of some longitudinal furrowing or striation on the original single shaft. That clustering or striation, whichever we choose to call it, is in this case a decorative feature, and to be considered under the head of decoration.

§ XXI. It must be evident to the reader at a glance, that the real serviceableness of any of these grouped arrangements must depend upon the relative shortness of the shafts, and that, when the whole pier is so lofty that its minor members become mere reeds or rods of stone, those minor members can no longer be charged with any considerable weight. And the fact is, that in the most complicated Gothic arrangements,

when the pier is tall and its satellites stand clear of it, no real work is given them to do, and they might all be removed without endangering the building. They are merely the *expression* of a great consistent system, and are in architecture what is often found in animal anatomy,—a bone, or process of a bone, useless, under the ordained circumstances of its life to the particular animal in which it is found, and slightly developed, but yet distinctly existent, and representing, for the sake of absolute consistency, the same bone in its appointed, and generally useful, place, either in skeletons of all animals, or in the genus to which the animal itself belongs.

§ XXII. Farther : as it is not easy to obtain pieces of stone long enough for these supplementary shafts (especially as it is always unsafe to lay a stratified stone with its beds upright), they have been frequently composed of two or more short shafts set upon each other, and to conceal the unsightly junction, a flat stone has been interposed, carved into certain mouldings, which have the appearance of a ring on the shaft. Now observe : the whole pier was the gathering of the whole wall, the base gathers into base, the veil into the shaft, and the string courses of the veil gather into these rings ; and when this is clearly expressed, and the rings do indeed correspond with the string courses of the wall veil, they are perfectly admissible and even beautiful ; but otherwise, and occurring, as they do in the shafts of Westminster, in the middle of continuous lines, they are but sorry make-shifts, and of late since gas has been invented, have become especially offensive from their unlucky resemblance to the joints of gas-pipes, or common water-pipes. There are two leaden ones, for instance, on the left hand as one enters the abbey at Poet's Corner, with their solderings and funnels looking exactly like rings and capitals, and most disrespectfully mimicking the shafts of the abbey, inside.

Thus far we have traced the probable conditions of shaft structure in pure theory ; I shall now lay before the reader a brief statement of the facts of the thing in time past and present.

§ XXIII. In the earliest and grandest shaft architecture which

we know, that of Egypt, we have no grouped arrangements, properly so called, but either single and smooth shafts, or richly reeded and furrowed shafts, which represent the extreme conditions of a complicated group bound together to sustain a single mass ; and are indeed, without doubt, nothing else than imitations of bundles of reeds, or of clusters of lotus :* but in these shafts there is merely the idea of a group, not the actual function or structure of a group ; they are just as much solid and simple shafts as those which are smooth, and merely by the method of their decoration present to the eye the image of a richly complex arrangement.

§ xxiv. After these we have the Greek shaft, less in scale, and losing all suggestion or purpose of suggestion of complexity, its so-called flutings being, visibly as actually, an external decoration.

§ xxv. The idea of the shaft remains absolutely single in the Roman and Byzantine mind ; but true grouping begins in Christian architecture by the placing of two or more separate shafts side by side, each having its own work to do ; then three or four, still with separate work ; then, by such steps as those above theoretically pursued, the number of the members increases, while they coagulate into a single mass ; and we have finally a shaft apparently composed of thirty, forty, fifty, or more distinct members ; a shaft which, in the reality of its service, is as much a single shaft as the old Egyptian one ; but which differs from the Egyptian in that all its members, how many soever, have each individual work to do, and a separate rib of arch or roof to carry : and thus the great Christian truth of distinct services of the individual soul is typified in the Christian shaft ; and the old Egyptian servitude of the multitudes, the servitude inseparable from the children of Ham, is typified also in that ancient shaft of the Egyptians, which in its gathered strength of the river reeds, seems, as the sands of the desert drift over its ruin, to be intended to remind us for ever of the end of the association of

* The capitals being formed by the flowers, or by a representation of the bulging out of the reeds at the top, under the weight of the architrave.

the wicked. "Can the rush grow up without mire, or the flag grow without water?—So are the paths of all that forget God; and the hypocrite's hope shall perish."

§ xxvi. Let the reader then keep this distinction of the three systems clearly in his mind: Egyptian system, an apparent cluster supporting a simple capital and single weight; Greek and Roman system, single shaft, single weight; Gothic system, divided shafts, divided weight: at first actually and simply divided, at last apparently and infinitely divided; so that the fully formed Gothic shaft is a return to the Egyptian, but the weight is divided in the one and undivided in the other.

§ xxvii. The transition from the actual to the apparent cluster, in the Gothic, is a question of the most curious interest; I have thrown together the shaft sections in Plate II. to illustrate it, and exemplify what has been generally stated above.*

1. The earliest, the most frequent, perhaps the most beautiful of all the groups, is also the simplest; the two shafts arranged as at *b* or *c*, (Fig. XIV.) above, bearing an oblong mass, and substituted for the still earlier structure *a*, Fig. XIV. In Plate XVII. (Chap. XXVII.) are three examples of the transition: the one on the left, at the top, is the earliest single-shafted arrangement, constant in the rough Romanesque windows; a huge hammer-shaped capital being employed to sustain the thickness of the wall. It was rapidly superseded by the double shaft, as on the right of it; a very early example from the cloisters of the Duomo, Verona. Beneath, is a most elaborate and perfect one from St. Zeno of Verona, where the group is twice complicated, two shafts being used, both with quatrefoil sections. The plain double shaft, however, is by far the most frequent, both in the Northern and Southern Gothic, but for the most part early; it is very frequent in cloisters, and in the singular one of St. Michael's Mount, Nor-

* I have not been at the pains to draw the complicated piers in this plate with absolute exactitude to the scale of each: they are accurate enough for their purpose: those of them respecting which we shall have farther question will be given on a much larger scale.

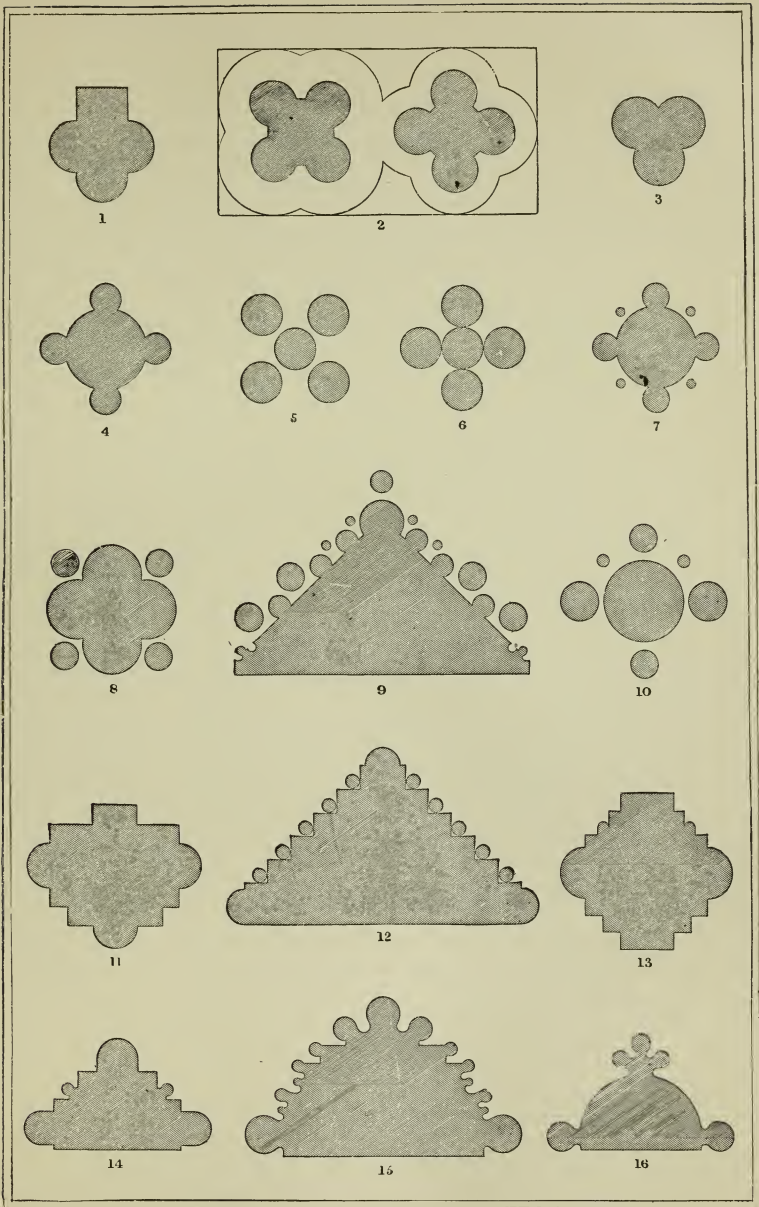

PLATE II.—PLANS OF PIERS.

mandy, a small pseudo-arcade runs along between the pairs of shafts, a miniature aisle. The group is employed on a magnificent scale, but ill proportioned, for the main piers of the apse of the cathedral of Coutances, its purpose being to conceal one shaft behind the other, and make it appear to the spectator from the nave as if the apse were sustained by single shafts, of inordinate slenderness. The attempt is ill-judged, and the result unsatisfactory.

§ XXVIII. 2. When these pairs of shafts come near each other, as frequently at the turnings of angles (Fig. XVII.), the quadruple group results, *b* 2, Fig. XIV., of which the Lombardic sculptors were excessively fond, usually tying the shafts together in their centre, in a lover's knot. They thus occur in Plate V.,

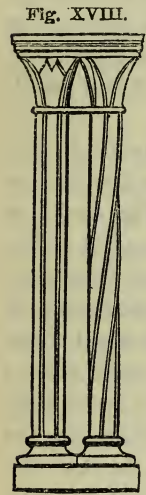

Fig. XVIII.

from the Broletto of Como; at the angle of St. Michele of Lucca, Plate XXI.; and in the balustrade of St. Mark's. This is a group, however, which I have never seen used on a large scale.*

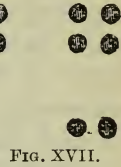

Fig. XVII.

§ XXIX. 3. Such groups, consolidated by a small square in their centre, form the shafts of St. Zeno, just spoken of, and figured in Plate XVII., which are among the most interesting pieces of work I know in Italy. I give their entire arrangement in Fig. XVIII.: both shafts have the same section, but one receives a half turn as it ascends, giving it an exquisite spiral contour: the plan of their bases, with their plinth, is given at 2, Plate II.; and note it carefully, for it is an epitome of all that we observed above, respecting the oblique and even square.

It was asserted that the oblique belonged to the north, the even to the south: we have here the northern Lombardic nation naturalised in Italy, and, behold, the oblique and even quatrefoil linked together; not confused, but actually linked by a bar of stone, as seen in Plate XVII., under the capitals.

* The largest I remember support a monument in St. Zeno of Verona; they are of red marble, some ten or twelve feet high.

4. Next to these, observe the two groups of five shafts each, 5 and 6, Plate II., one oblique, the other even. Both are from upper stories; the oblique one from the triforium of Salisbury; the even one from the upper range of shafts in the façade of St. Mark's at Venice.*

§ xxx. Around these central types are grouped, in Plate II., four simple examples of the satellitic cluster, all of the Northern Gothic: 4, from the Cathedral of Amiens; 7, from that of Lyons (nave pier); 8, the same from Salisbury; 10, from the porch of Notre Dame, Dijon, having satellites of three magnitudes: 9 is one of the piers between the doors of the same church, with shafts of four magnitudes, and is an instance of the confusion of mind of the Northern architects between piers proper and jamb mouldings (noticed farther in the next chapter, § xxxi.): for this fig. 9, which is an angle at the meeting of two jambs, is treated like a rich independent shaft, and the figure below, 12, which is half of a true shaft, is treated like a meeting of jambs.

All these four examples belonging to the oblique or Northern system, the curious trefoil plan, 3, lies *between* the two, as the double quatrefoil next it *unites* the two. The trefoil is from the Frari, Venice, and has a richly worked capital in the Byzantine manner,—an imitation, I think, of the Byzantine work by the Gothic builders: 1 is to be compared with it, being one of the earliest conditions of the cross shaft, from the atrium of St. Ambrogio at Milan. 13 is the nave pier of St. Michele at Pavia, showing the same condition more fully developed: and 11 another nave pier from Vienne, on the Rhone, of far more distinct Roman derivation, for the flat pilaster is set to the nave, and is fluted like an antique one. 12 is the grandest development I have ever seen of the cross shaft, with satellite shafts in the nooks of it: it is half of one of the great western piers of the cathedral of Bourges, measuring eight feet each side, thirty-two round.† Then the one

* The effect of this last is given in Plate VI. of the folio series.

† The entire development of this cross system in connection with the vaulting ribs, has been most clearly explained by Professor Willis (Architecture of Mid. Ages, Chap. IV.); and I strongly recommend

below (15) is half of a nave pier of Rouen Cathedral, showing the mode in which such conditions as that of Dijon (9) and that of Bourges (12) were fused together into forms of inextricable complexity (inextricable I mean in the irregularity of proportion and projection, for all of them are easily resolvable into simple systems in connection with the roof ribs). This pier of Rouen is a type of the last condition of the good Gothic ; from this point the small shafts begin to lose shape, and run into narrow fillets and ridges, projecting at the same time farther and farther in weak tongue-like sections, as described in the "Seven Lamps." I have only here given one example of this family, an unimportant but sufficiently characteristic one (16) from St. Gervais of Falaise. One side of the nave of that church is Norman, the other Flamboyant, and the two piers 14 and 16 stand opposite each other. It would be useless to endeavor to trace farther the fantasticism of the later Gothic shafts ; they become mere aggregations of mouldings very sharply and finely cut, their bases at the same time running together in strange complexity and their capitals diminishing and disappearing. Some of their conditions, which, in their rich striation, resemble crystals of beryl, are very massy and grand ; others, meagre, harsh, or effeminate in themselves, are redeemed by richness and boldness of decoration ; and I have long had it in my mind to reason out the entire harmony of this French Flamboyant system, and fix its types and possible power. But this inquiry is foreign altogether to our present purpose, and we shall therefore turn back from the Flamboyant to the Norman side of the Falaise aisle, resolute for the future that all shafts of which we may have the ordering, shall be permitted, as with wisdom we may also permit men or cities, to gather themselves into companies, or constellate themselves into clusters, but not to fuse themselves into mere masses of nebulous aggregation.

every reader who is inclined to take pains in the matter, to read that chapter. I have been contented, in my own text, to pursue the abstract idea of shaft form.

CHAPTER IX.

THE CAPITAL.

§ I. THE reader will remember that in Chap. VII. § v. it was said that the cornice of the wall, being cut to pieces and gathered together, formed the capital of the column. We have now to follow it in its transformation.

We must, of course, take our simplest form or root of cornices (*a*, in Fig. V., above). We will take X and Y there, and we must necessarily gather them together as we did Xb and Yb in Chap. VII. Look back to the tenth paragraph of Chap. VII., read or glance it over again, substitute X and Y for Xb and Yb, read capital for base, and, as we said that the capital was the hand of the pillar, while the base was its foot, read also fingers for toes; and as you look to the plate, Fig. XII., turn it upside down. Then *h*, in Fig. XII., becomes now your best general form of block capital, as before of block base.

§ II. You will thus have a perfect idea of the analogies between base and capital; our farther inquiry is into their differences. You cannot but have noticed that when Fig. XII. is turned upside down, the square stone (Y) looks too heavy for the supporting stone (X); and that in the profile of cornice (*a* of Fig. V.) the proportions are altogether different. You will feel the fitness of this in an instant when you consider that the principal function of the sloping part in Fig. XII. is as a prop to the pillar to keep it from *slipping aside*; but the function of the sloping stone in the cornice and capital is to *carry weight above*. The thrust of the slope in the one case should therefore be lateral, in the other upwards.

§ III. We will, therefore, take the two figures, *e* and *h* of Fig. XII., and make this change in them as we reverse them, using now the exact profile of the cornice *a*,—the father of cornices; and we shall thus have *a* and *b*, Fig. XIX.

Both of these are sufficiently ugly, the reader thinks; so do I; but we will mend them before we have done with them:

that at *a* is assuredly the ugliest,—like a tile on a flower-pot. It is, nevertheless, the father of capitals ; being the simplest condition of the gathered father of cornices. But it is to be observed that the diameter of the shaft here is arbitrarily assumed to be small, in order more clearly to show the general relations of the sloping stone to the shaft and upper stone ; and this smallness of the shaft diameter is inconsistent with the serviceableness and beauty of the arrangement at *a*,

if it were to be realised (as we shall see presently) ; but it is not inconsistent with its central character, as the representative of every species of possible capital ; nor is its tile and flower-pot look to be regretted, as it may remind the reader of the reported origin of the Corinthian capital. The stones of the cornice, hitherto called X and Y, receive, now that they form the capital,

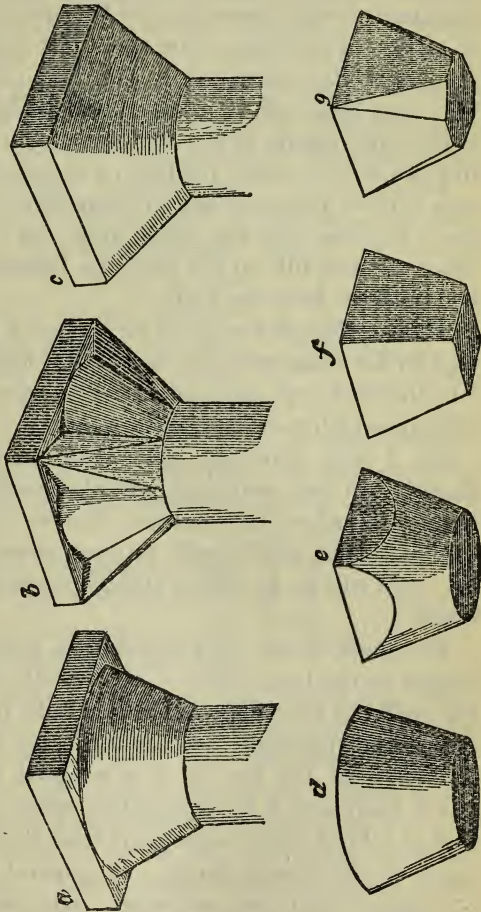

FIG. XIX.

each a separate name ; the sloping stone is called the Bell of the capital, and that laid above it, the Abacus. Abacus means

a board or tile: I wish there were an English word for it, but I fear there is no substitution possible, the term having been long fixed, and the reader will find it convenient to familiarise himself with the Latin one.

§ IV. The form of base, *e* of Fig. XII., which corresponds to this first form of capital, *a*, was said to be objectionable only because it *looked* insecure; and the spurs were added as a kind of pledge of stability to the eye. But evidently the projecting corners of the abacus at *a*, Fig. XIX., are *actually* insecure; they may break off, if great weight be laid upon them. This is the chief reason of the ugliness of the form; and the spurs in *b* are now no mere pledges of apparent stability, but have very serious practical use in supporting the angle of the abacus. If, even with the added spur, the support seems insufficient, we may fill up the crannies between the spurs and the bell, and we have the form *c*.

Thus *a*, though the germ and type of capitals, is itself (except under some peculiar conditions) both ugly and insecure; *b* is the first type of capitals which carry light weight; *c*, of capitals which carry excessive weight.

§ v. I fear, however, the reader may think he is going slightly too fast, and may not like having the capital forced upon him out of the cornice; but would prefer inventing a capital for the shaft itself, without reference to the cornice at all. We will do so then; though we shall come to the same result.

The shaft, it will be remembered, has to sustain the same weight as the long piece of wall which was concentrated into the shaft; it is enabled to do this both by its better form and better knit materials; and it can carry a greater weight than the space at the top of it is adapted to receive. The first point, therefore, is to expand this space as far as possible, and that in a form more convenient than the circle for the adjustment of the stones above. In general the square is a more convenient form than any other; but the hexagon or octagon is sometimes better fitted for masses of work which divide in six or eight directions. Then our first impulse would be to put a square or hexagonal stone on the top of the shaft, pre-

jecting as far beyond it as might be safely ventured ; as at *a*, Fig. XX. This is the abacus. Our next idea would be to put a conical shaped stone beneath this abacus, to support its outer edge, as at *b*. This is the bell.

§ VI. Now the entire treatment of the capital depends simply on the manner in which this bell-stone is prepared for fitting the shaft below and the abacus above. Placed as at *a*, in Fig. XIX., it gives us the simplest of possible forms ; with the spurs added, as at *b*, it gives the germ of the richest and most elaborate forms : but there are two modes of treatment more dexterous than the one, and less elaborate than the other, which are of the highest possible importance,—modes in which the bell is brought to its proper form by truncation.

§ VII. Let *d* and *f*, Fig. XIX., be two bell-stones ; *d* is part of a cone (a sugar-loaf upside down, with its point cut off) ; *f* part of a four-sided pyramid. Then, assuming the abacus to be square, *d* will already fit the shaft, but has to be chiselled to fit the abacus ; *f* will already fit the abacus, but has to be chiselled to fit the shaft.

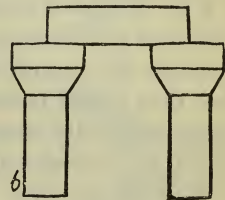
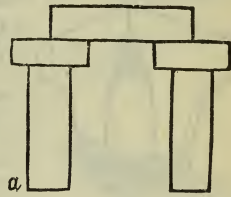

FIG. XX.

From the broad end of *d* chop or chisel off, in four vertical planes, as much as will leave its head an exact square. The vertical cuttings will form curves on the sides of the cone (curves of a curious kind, which the reader need not be troubled to examine), and we shall have the form at *c*, which is the root of the greater number of Norman capitals.

From *f* cut off the angles, beginning at the corners of the square and widening the truncation downwards, so as to give the form at *g*, where the base of the bell is an octagon, and its top remains a square. A very slight rounding away of the angles of the octagon at the base of *g* will enable it to fit the circular shaft closely enough for all practical purposes, and this form, at *g*, is the root of nearly all Lombardic capitals.

If, instead of a square, the head of the bell were hexagonal

or octagonal, the operation of cutting would be the same on each angle; but there would be produced, of course, six or eight curves on the sides of *e*, and twelve or sixteen sides to the base of *g*.

§ VIII. The truncations in *e* and *g* may of course be executed on concave or convex forms of *d* and *f*; but *e* is usually worked on a straight-sided bell, and the truncation of *g* often becomes concave while the bell remains straight; for this simple reason,—that the sharp points at the angles of *g*, being somewhat difficult to cut, and easily broken off, are usually avoided by beginning the truncation a little way down the side of the bell, and then recovering the lost ground by a deeper cut inwards, as here, Fig. XXI. This is the actual form of the capitals of the balustrades of St. Mark's: it is the root of all the Byzantine Arab capitals, and of all the most beautiful capitals in the world, whose function is to express lightness.

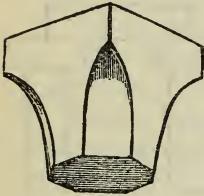

FIG. XXI.

§ IX. We have hitherto proceeded entirely on the assumption that the form of cornice which was gathered together to produce the capital was the root of cornices, *a* of Fig. V. But this, it will be remembered, was said in § VI. of Chap. VI. to be especially characteristic of southern work, and that in northern and wet climates it took the form of a dripstone.

Accordingly, in the northern climates, the dripstone gathered together forms a peculiar northern capital, commonly called the Early English,* owing to its especial use in that style.

There would have been no absurdity in this if shafts were always to be exposed to the weather; but in Gothic constructions the most important shafts are in the inside of the building. The dripstone sections of their capitals are therefore unnecessary and ridiculous.

§ X. They are, however, much worse than unnecessary.

The edge of the dripstone, being undercut, has no bearing power, and the capital fails, therefore, in its own principal

* Appendix 19, "Early English Capitals."

function ; and besides this, the undercut contour admits of no distinctly visible decoration ; it is, therefore, left utterly barren, and the capital looks as if it had been turned in a lathe. The Early English capital has, therefore, the three greatest faults that any design can have : (1) it fails in its own proper purpose, that of support ; (2) it is adapted to a purpose to which it can never be put, that of keeping off rain ; (3) it cannot be decorated.

The Early English capital is, therefore, a barbarism of triple grossness, and degrades the style in which it is found, otherwise very noble, to one of second-rate order.

§ XI. Dismissing, therefore, the Early English capital, as deserving no place in our system, let us reassemble in one view the forms which have been legitimately developed, and which are to become hereafter subjects of decoration. To the forms *a*, *b*, and *c*, Fig. XIX., we must add the two simplest truncated forms *e* and *g*, Fig. XIX., putting their abaci on them (as we considered their contours in the bells only), and we shall have the five forms now given in parallel perspective in Fig. XXII., which are the roots of all good capitals existing, or capable of existence, and whose variations, infinite and a thousand times infinite, are all produced by introduction of various curvatures into their contours, and the endless methods of decoration superinduced on such curvatures.

§ XII. There is, however, a kind of variation, also infinite, which takes place in these radical forms, before they receive either curvature or decoration. This is the variety of proportion borne by the different lines of the capital to each other, and to the shafts. This is

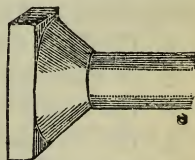
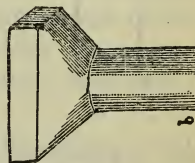
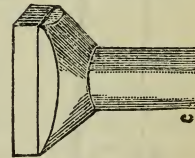
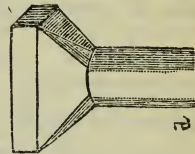
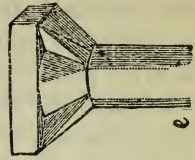

FIG. XXII.

a structural question, at present to be considered as far as is possible.

§ XIII. All the five capitals (which are indeed five orders with legitimate distinction ; very different, however, from the five orders as commonly understood) may be represented by the same profile, a section through the sides of *a*, *b*, *d*, and *e*, or through the angles of *c*, Fig. XXII. This profile we will put on the top of a shaft, as at A, Fig. XXIII., which shaft we will suppose of equal diameter above and below for the sake of greater simplicity : in this simplest condition, how-

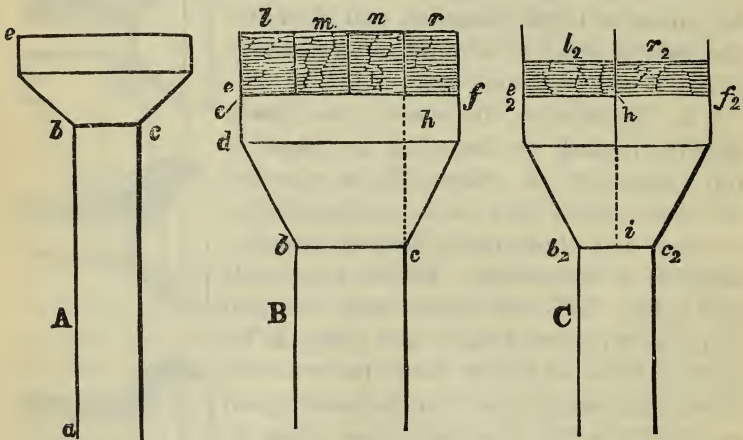

FIG. XXIII.

ever, relations of proportion exist between five quantities, any one, or any two, or any three, or any four of which may change, irrespective of the others. These five quantities are :

1. The height of the shaft, *a b* ;
2. Its diameter, *b c* ;
3. The length of slope of bell, *b d* ;
4. The inclination of this slope, or angle *c b d* ;
5. The depth of abacus, *d e*.

For every change in any one of these quantities we have a new proportion of capital : five infinities, supposing change only in one quantity at a time : infinity of infinities in the sum of possible changes.

It is, therefore, only possible to note the general laws of change ; every scale of pillar, and every weight laid upon it admitting, within certain limits, a variety out of which the architect has his choice ; but yet fixing limits which the proportion becomes ugly when it approaches, and dangerous when it exceeds. But the inquiry into this subject is too difficult for the general reader, and I shall content myself with proving four laws, easily understood and generally applicable ; for proof of which if the said reader care not, he may miss the next four paragraphs without harm.

§ XIV. 1. *The more slender the shaft, the greater, proportionally, may be the projection of the abacus.* For, looking back to Fig. XXIII., let the height ab be fixed, the length db , the angle dbc , and the depth de . Let the single quantity bc be variable, let B be a capital and shaft which are found to be perfectly safe in proportion to the weight they bear, and let the weight be equally distributed over the whole of the abacus. Then this weight may be represented by any number of equal divisions, suppose four, as l, m, n, r , of brickwork above, of which each division is one fourth of the whole weight ; and let this weight be placed in the most trying way on the abacus, that is to say, let the masses l and r be detached from m and n , and bear with their full weight on the outside of the capital. We assume, in B, that the width of abacus ef is twice as great as that of the shaft, bc , and on these conditions we assume the capital to be safe.

But bc is allowed to be variable. Let it become $b_2 c_2$ at C, which is a length representing about the diameter of a shaft containing half the substance of the shaft B, and, therefore, able to sustain not more than half the weight sustained by B. But the slope bd and depth de remaining unchanged, we have the capital of C, which we are to load with only half the weight of l, m, n, r , i. e., with l and r alone. Therefore the weight of l and r , now represented by the masses $l_2 r_2$, is distributed over the whole of the capital. But the weight r was adequately supported by the projecting piece of the first capital hfc : much more is it now adequately supported by $ih, f_2 c_2$. Therefore, if the capital of B was safe, that of C is

more than safe. Now in B the length ef was only twice $b c$; but in C, $e_2 f_2$ will be found more than twice that of $b_2 c_2$. Therefore, the more slender the shaft, the greater may be the proportional excess of the abacus over its diameter.

§ xv. 2. *The smaller the scale of the building, the greater may be the excess of the abacus over the diameter of the shaft.* This principle requires, I think, no very lengthy proof: the reader can understand at once that the cohesion and strength of stone which can sustain a small projecting mass, will not sustain a vast one overhanging in the same proportion. A bank even of loose earth, six feet high, will sometimes overhang its base a foot or two, as you may see any day in the gravelly banks of the lanes of Hampstead: but make the bank of gravel, equally loose, six hundred feet high, and see if you can get it to overhang a hundred or two! much more if there be weight above it increased in the same proportion. Hence, let any capital be given, whose projection is just safe, and no more, on its existing scale; increase its proportions every way equally, though ever so little, and it is unsafe; diminish them equally, and it becomes safe in the exact degree of the diminution.

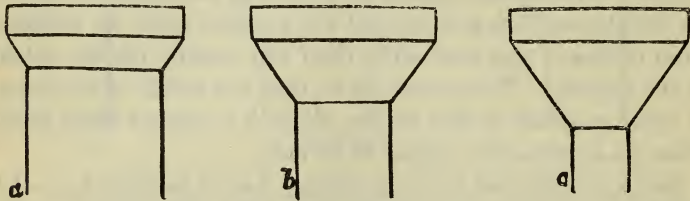

FIG. XXIV.

Let, then, the quantity ed , and angle dbc , at A of Fig XXIII., be invariable, and let the length db vary: then we shall have such a series of forms as may be represented by a , b , c , Fig. XXIV., of which a is a proportion for a colossal building, b for a moderately sized building, while c could only be admitted on a very small scale indeed.

§ xvi. 3. *The greater the excess of abacus, the steeper must be the slope of the bell, the shaft diameter being constant.*

This will evidently follow from the considerations in the last paragraph; supposing only that, instead of the scale of

shaft and capital varying together, the scale of the capital varies alone. For it will then still be true, that, if the projection of the capital be just safe on a given scale, as its excess over the shaft diameter increases, the projection will be unsafe, if the slope of the bell remain constant. But it may be rendered safe by making this slope steeper, and so increasing its supporting power.

Thus let the capital *a*, Fig. XXV., be just safe. Then the capital *b*, in which the slope is the same but the excess greater, is unsafe. But the capital *c*, in which, though the excess equals that of *b*, the steepness of the supporting slope is increased, will be as safe as *b*, and probably as strong as *a*.*

§ XVII. 4. *The steeper the slope of the bell, the thinner may be the abacus.*

The use of the abacus is eminently to equalise the pressure over the surface of the bell, so that the weight may not by any accident be directed exclusively upon its edges. In proportion to the strength of these edges, this function of the abacus is superseded, and these edges are strong in proportion to the steepness of the slope. Thus in Fig. XXVI, the bell at *a* would carry weight safely enough without any abacus, but that at *c* would not: it would probably have its edges broken off. The abacus superimposed might be on *a* very thin, little more than formal, as at *b*; but on *c* must be thick, as at *d*.

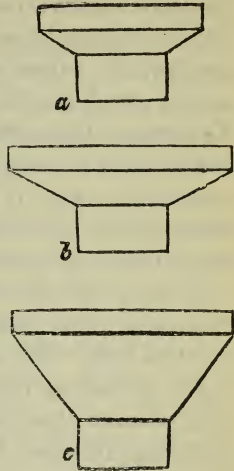

FIG. XXV.

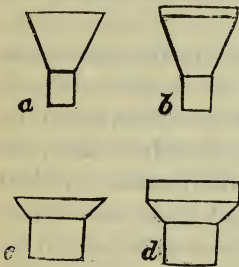

FIG. XXVI.

§ XVIII. These four rules are all that are necessary for general

* In this case the weight borne is supposed to increase as the abacus widens; the illustration would have been clearer if I had assumed the breadth of abacus to be constant, and that of the shaft to vary.

criticism ; and observe that these are only semi-imperative,—rules of permission, not of compulsion. Thus Law 1 asserts that the slender shaft *may* have greater excess of capital than the thick shaft ; but it need not, unless the architect chooses ; his thick shafts *must* have small excess, but his slender ones need not have large. So Law 2 says, that as the building is smaller, the excess *may* be greater ; but it need not, for the excess which is safe in the large is still safer in the small. So Law 3 says that capitals of great excess must have steep slopes ; but it does not say that capitals of small excess may not have steep slopes also, if we choose. And lastly, Law 4 asserts the necessity of the thick abacus for the shallow bell ; but the steep bell may have a thick abacus also.

§ xix. It will be found, however, that in practice some confession of these laws will always be useful, and especially of the two first. The eye always requires, on a slender shaft, a more spreading capital than it does on a massy one, and a bolder mass of capital on a small scale than on a large. And, in the application of the first rule, it is to be noted that a shaft becomes slender either by diminution of diameter or increase of height ; that either mode of change presupposes the weight above it diminished, and requires an expansion of abacus. I know no mode of spoiling a noble building more frequent in actual practice than the imposition of flat and slightly expanded capitals on tall shafts.

§ xx. The reader must observe, also, that, in the demonstration of the four laws, I always assumed the weight above to be given. By the alteration of this weight, therefore, the architect has it in his power to relieve, and therefore alter, the forms of his capitals. By its various distribution on their centres or edges, the slope of their bells and thickness of abaci will be affected also ; so that he has countless expedients at his command for the various treatment of his design. He can divide his weights among more shafts ; he can throw them in different places and different directions on the abaci ; he can alter slope of bells or diameter of shafts ; he can use spurred or plain bells, thin or thick abaci ; and all these changes admitting of infinity in their degrees, and infinity a thousand

times told in their relations : and all this without reference to decoration, merely with the five forms of block capital !

§ XXI. In the harmony of these arrangements, in their fitness, unity, and accuracy, lies the true proportion of every building,—proportion utterly endless in its infinities of change, with unchanged beauty. And yet this connection of the frame of their building into one harmony has, I believe, never been so much as dreamed of by architects. It has been instinctively done in some degree by many, empirically in some degree by many more ; thoughtfully and thoroughly, I believe, by none.

§ XXII. We have hitherto considered the abacus as necessarily a separate stone from the bell : evidently, however, the strength of the capital will be undiminished if both are cut out of one block. This is actually the case in many capitals, especially those on a small scale ; and in others the detached upper stone is a mere representative of the abacus, and is much thinner than the form of the capital requires, while the true abacus is united with the bell, and concealed by its decoration, or made part of it.

§ XXIII. Farther. We have hitherto considered bell and abacus as both derived from the concentration of the cornice. But it must at once occur to the reader, that the projection of the under stone and the thickness of the upper, which are quite enough for the work of the continuous cornice, may not be enough always, or rather are seldom likely to be so, for the harder work of the capital. Both may have to be deepened and expanded : but as this would cause a want of harmony in the parts, when they occur on the same level, it is better in such case to let the *entire* cornice form the abacus of the capital, and put a deep capital bell beneath it.

§ XXIV. The reader will understand both arrangements instantly by two examples. Fig. XXVII. represents two windows, more than usually beautiful examples of a very frequent Venetian form. Here the deep cornice or string course which runs along the wall of the house is quite strong enough for the work of the capitals of the slender shafts : its own upper stone is therefore also theirs ; its own lower stone, by its

revolution or concentration, forms their bells : but to mark the increased importance of its function in so doing, it receives decoration, as the bell of the capital, which it did not receive as the under stone of the cornice.

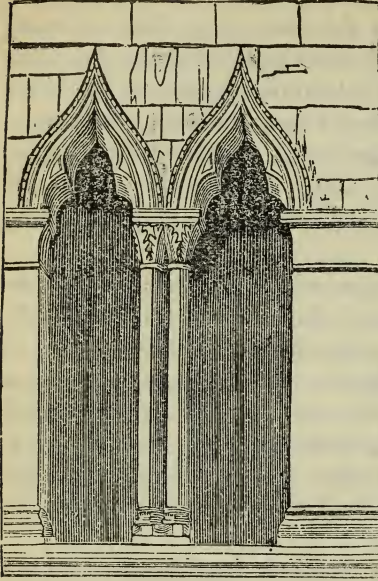

FIG. XXVII.

In Fig. XXVIII., a little bit of the church of Santa Fosca at Torcello, the cornice or string course, which goes round every part of the church, is not strong enough to form the capitals of the shafts. It therefore forms their abaci only ; and in order to mark the diminished importance of its function, it ceases to receive, as the abacus of the capital, the decoration which it received as the string course of the wall.

This last arrangement is of great frequency in Venice, occurring most characteristically in St. Mark's : and in the Gothic of St. John and Paul we find the two arrangements beautifully united, though in great simplicity ; the string courses of the walls form the capitals of the shafts of the traceries, and the abaci of the vaulting shafts of the apse.

§ xxv. We have hitherto spoken of capitals of circular shafts only : those of square piers are more frequently formed by the cornice only ; otherwise they are like those of circular piers, without the difficulty of reconciling the base of the bell with its head.

§ xxvi. When two or more shafts are grouped together, their capitals are usually treated as separate, until they come into actual contact. If there be any awkwardness in the junction, it is concealed by the decoration, and one abacus serves, in most cases, for all. The double group, Fig. XXVII.

is the simplest possible type of the arrangement. In the richer Northern Gothic groups of eighteen or twenty shafts cluster together, and sometimes the smaller shafts crouch under the capitals of the larger, and hide their heads in the crannies, with small nominal abaci of their own, while the larger shafts carry the serviceable abacus of the whole pier, as in the nave of Rouen. There is, however, evident sacrifice of sound principle in this system, the smaller abaci being of no use. They are the exact contrary of the rude early abacus at Milan, given in Plate XVII. There one poor abacus

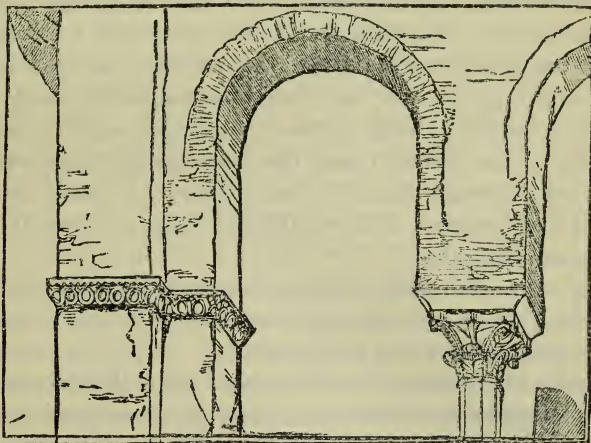

FIG. XXVIII.

stretched itself out to do all the work: here there are idle abaci getting up into corners and doing none.

§ xxvii. Finally, we have considered the capital hitherto entirely as an expansion of the bearing power of the shaft, supposing the shaft composed of a single stone. But, evidently, the capital has a function, if possible, yet more important, when the shaft is composed of small masonry. It enables all that masonry to act together, and to receive the pressure from above collectively and with a single strength. And thus, considered merely as a large stone set on the top of the shaft, it is a feature of the highest architectural importance, irrespec-

tive of its expansion, which indeed is, in some very noble capitals, exceedingly small. And thus every large stone set at any important point to reassemble the force of smaller masonry and prepare it for the sustaining of weight, is a capital or "head" stone (the true meaning of the word) whether it project or not. Thus at 6, in Plate IV., the stones which support the thrust of the brickwork are capitals, which have no projection at all; and the large stones in the window above are capitals projecting in one direction only.

§ XXVIII. The reader is now master of all he need know respecting construction of capitals; and from what has been laid before him, must assuredly feel that there can never be any new system of architectural forms invented; but that all vertical support must be, to the end of time, best obtained by shafts and capitals. It has been so obtained by nearly every nation of builders, with more or less refinement in the management of the details; and the later Gothic builders of the North stand almost alone in their effort to dispense with the natural development of the shaft, and banish the capital from their compositions.

They were gradually led into this error through a series of steps which it is not here our business to trace. But they may be generalised in a few words.

§ XXIX. All classical architecture, and the Romanesque which is legitimately descended from it, is composed of bold independent shafts, plain or fluted, with bold detached capitals, forming arcades or colonnades where they are needed; and of walls whose apertures are surrounded by courses of parallel lines called mouldings, which are continuous round the apertures, and have neither shafts nor capitals. The shaft system and moulding system are entirely separate.

The Gothic architects confounded the two. They clustered the shafts till they looked like a group of mouldings. They shod and capitated the mouldings till they looked like a group of shafts. So that a pier became merely the side of a door or window rolled up, and the side of the window a pier unrolled (vide last Chapter, § xxx.), both being composed of a series of small shafts, each with base and capital. The architect seemed

to have whole mats of shafts at his disposal, like the rush mats which one puts under cream cheese. If he wanted a great pier he rolled up the mat ; if he wanted the side of a door he spread out the mat ; and now the reader has to add to the other distinctions between the Egyptian and the Gothic shaft, already noted in § xxvi. of Chap. VIII., this one more—the most important of all—that while the Egyptian rush cluster has only one massive capital altogether, the Gothic rush mat has a separate tiny capital to every several rush.

§ xxx. The mats were gradually made of finer rushes, until it became troublesome to give each rush its capital. In fact, when the groups of shafts became excessively complicated, the expansion of their small abaci was of no use : it was dispensed with altogether, and the mouldings of pier and jamb ran up continuously into the arches.

This condition, though in many respects faulty and false, is yet the eminently characteristic state of Gothic : it is the definite formation of it as a distinct style, owing no farther aid to classical models ; and its lightness and complexity render it, when well treated, and enriched with Flamboyant decoration, a very glorious means of picturesque effect. It is, in fact, this form of Gothic which commends itself most easily to the general mind, and which has suggested the innumerable foolish theories about the derivation of Gothic from tree trunks and avenues, which have from time to time been brought forward by persons ignorant of the history of architecture.

§ xxxi. When the sense of picturesqueness, as well as that of justness and dignity, had been lost, the spring of the continuous mouldings was replaced by what Professor Willis calls the Discontinuous impost ; which, being a barbarism of the basest and most painful kind, and being to architecture what the setting of a saw is to music, I shall not trouble the reader to examine. For it is not in my plan to note for him all the various conditions of error, but only to guide him to the appreciation of the right ; and I only note even the true Continuous or Flamboyant Gothic because this is redeemed by its beautiful decoration, afterwards to be considered. For, as far as structure is concerned, the moment the capital vanishes

from the shaft, that moment we are in error : all good Gothia has true capitals to the shafts of its jambs and traceries, and all Gothic is debased the instant the shaft vanishes. It matters not how slender, or how small, or how low, the shaft may be : wherever there is indication of concentrated vertical support, then the capital is a necessary termination. I know how much Gothic, otherwise beautiful, this sweeping principle condemns ; but it condemns not altogether. We may still take delight in its lovely proportions, its rich decoration, or its elastic and reedy moulding ; but be assured, wherever shafts, or any approximations to the forms of shafts, are employed, for whatever office, or on whatever scale, be it in jambs or piers, or balustrades, or traceries, without capitals, there is a defiance of the natural laws of construction ; and that, wherever such examples are found in ancient buildings, they are either the experiments of barbarism, or the commencements of decline.

CHAPTER X.

THE ARCH LINE.

§ 1. WE have seen in the last section how our means of vertical support may, for the sake of economy both of space and material, be gathered into piers or shafts, and directed to the sustaining of particular points. The next question is how to connect these points or tops of shafts with each other, so as to be able to lay on them a continuous roof. This the reader, as before, is to favor me by finding out for himself, under these following conditions.

Let *s, s*, Fig. XXIX., opposite, be two shafts, with their capitals ready prepared for their work ; and *a, b, b*, and *c, c, c*, be six stones of different sizes, one very long and large, and two smaller, and three smaller still, of which the reader is to choose which he likes best, in order to connect the tops of the shafts.

I suppose he will first try if he can lift the great stone *a*, and if he can, he will put it very simply on the tops of the two pillars, as at *A*.

Very well indeed : he has done already what a number of Greek architects have been thought very clever for having done. But suppose he *cannot* lift the great stone *a*, or sup-

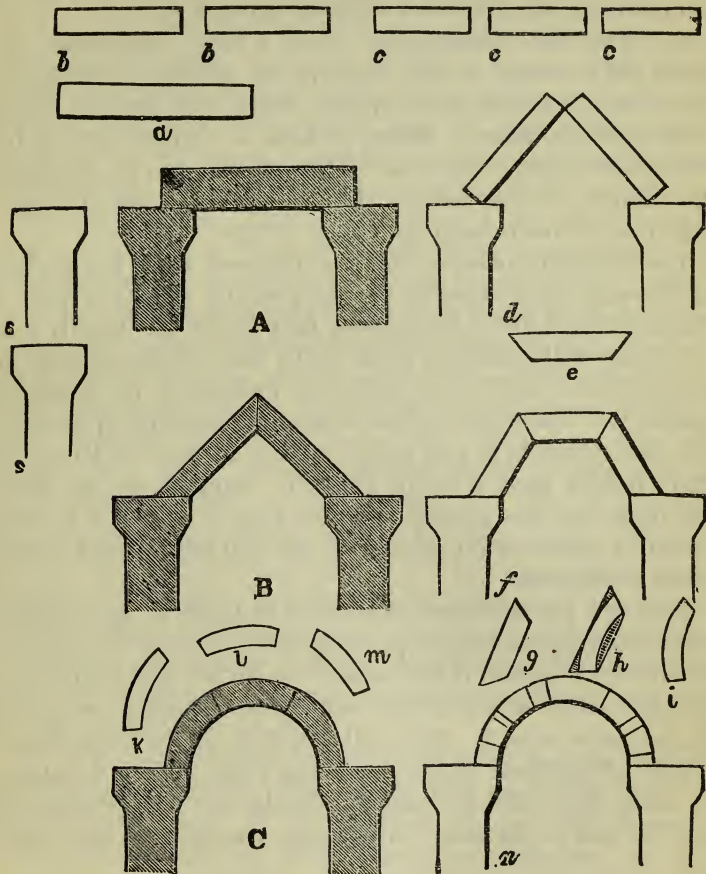

FIG. XXIX.

pose I will not give it to him, but only the two smaller stones at *b, b*; he will doubtless try to put them up, tilted against each other, as at *d*. Very awkward this; worse than card-house building. But if he cuts off the corners of the stones,

so as to make each of them of the form *e*, they will stand up very securely, as at B.

But suppose he cannot lift even these less stones, but can raise those at *c, c, c*. Then, cutting each of them into the form at *e*, he will doubtless set them up as at *f*.

§ II. This last arrangement looks a little dangerous. Is there not a chance of the stone in the middle pushing the others out, or tilting them up and aside, and slipping down itself between them? There is such a chance: and if by somewhat altering the form of the stones, we can diminish this chance, all the better. I must say "we" now, for perhaps I may have to help the reader a little.

The danger is, observe, that the midmost stone at *f* pushes out the side ones: then if we can give the side ones such a shape as that, left to themselves, they would fall heavily forward, they will resist this push *out* by their weight, exactly in proportion to their own particular inclination or desire to tumble *in*. Take one of them separately, standing up as at *g*; it is just possible it may stand up as it is, like the Tower of Pisa: but we want it to fall forward. Suppose we cut away the parts that are shaded at *h* and leave it as at *i*, it is very certain it cannot stand alone now, but will fall forward to our entire satisfaction.

Farther: the midmost stone at *f* is likely to be troublesome chiefly by its weight, pushing down between the others; the more we lighten it the better: so we will cut it into exactly the same shape as the side ones, chiselling away the shaded parts, as at *h*. We shall then have all the three stones *k, l, m*, of the same shape; and now putting them together, we have, at C, what the reader, I doubt not, will perceive at once to be a much more satisfactory arrangement than that at *f*.

§ III. We have now got three arrangements; in one using only one piece of stone, in the second two, and in the third three. The first arrangement has no particular name, except the "horizontal:" but the single stone (or beam, it may be,) is called a lintel; the second arrangement is called a "Gable;" the third an "Arch."

We might have used pieces of wood instead of stone in all these arrangements, with no difference in plan, so long as the beams were kept loose, like the stones ; but as beams can be securely nailed together at the ends, we need not trouble ourselves so much about their shape or balance, and therefore the plan at *f* is a peculiarly wooden construction (the reader will doubtless recognise in it the profile of many a farm-house roof) : and again, because beams are tough, and light, and long, as compared with stones, they are admirably adapted for the constructions at A and B, the plain lintel and gable, while that at C is, for the most part, left to brick and stone.

§ iv. But farther. The constructions, A, B, and C, though very conveniently to be first considered as composed of one, two, and three pieces, are by no means necessarily so. When we have once cut the stones of the arch into a shape like that of *k*, *l*, and *m*, they will hold together, whatever their number, place, or size, as at *n* ; and the great value of the arch is, that it permits small stones to be used with safety instead of large ones, which are not always to be had. Stones cut into the shape of *k*, *l*, and *m*, whether they be short or long (I have drawn them all sizes at *n* on purpose), are called *Voussoirs* ; this is a hard, ugly French name ; but the reader will perhaps be kind enough to recollect it ; it will save us both some trouble : and to make amends for this infliction, I will relieve him of the term *keystone*. One *voussoir* is as much a keystone as another ; only people usually call the stone which is last put in the keystone ; and that one happens generally to be at the top or middle of the arch.

§ v. Not only the arch, but even the lintel, may be built of many stones or bricks. The reader may see lintels built in this way over most of the windows of our brick London houses, and so also the gable : there are, therefore, two distinct questions respecting each arrangement :—First, what is the line or direction of it, which gives it its strength ? and, secondly, what is the manner of masonry of it, which gives it its consistence ? The first of these I shall consider in this Chapter under the head of the Arch Line, using the term arch as including an manner of construction (though we shall

have no trouble except about curves); and in the next Chapter I shall consider the second, under the head, Arch Masonry.

§ VI. Now the arch line is the ghost or skeleton of the arch; or rather it is the spinal marrow of the arch, and the voussoirs are the vertebræ, which keep it safe and sound, and clothe it. This arch line the architect has first to conceive and shape in his mind, as opposed to, or having to bear, certain forces which will try to distort it this way and that; and against which he is first to direct and bend the line itself into as strong resistance as he may, and then, with his voussoirs and what else he can, to guard it, and help it, and keep it to its duty and in its shape. So the arch line is the moral character of the arch, and the adverse forces are its temptations; and the voussoirs, and what else we may help it with, are its armor and its motives to good conduct.

§ VII. This moral character of the arch is called by architects its "Line of Resistance." There is a great deal of nicety in calculating it with precision, just as there is sometimes in finding out very precisely what is a man's true line of moral conduct; but this, in arch morality and in man morality, is a very simple and easily to be understood principle,—that if either arch or man expose themselves to their special temptations or adverse forces, *outside* of the voussoirs or proper and appointed armor, both will fall. An arch whose line of resistance is in the middle of its voussoirs is perfectly safe: in proportion as the said line runs near the edge of its voussoirs, the arch is in danger, as the man is who nears temptation; and the moment the line of resistance emerges out of the voussoirs the arch falls.

§ VIII. There are, therefore, properly speaking, two arch lines. One is the visible direction or curve of the arch, which may generally be considered as the under edge of its voussoirs, and which has often no more to do with the real stability of the arch, than a man's apparent conduct has with his heart. The other line, which is the line of resistance, or line of good behavior, may or may not be consistent with the outward and apparent curves of the arch; but if not, then the security of the arch depends simply upon this, whether the

voussoirs which assume or pretend to the one line are wide enough to include the other.

§ ix. Now when the reader is told that the line of resistance varies with every change either in place or quantity of the weight above the arch, he will see at once that we have no chance of arranging arches by their moral characters: we can only take the apparent arch line, or visible direction, as a ground of arrangement. We shall consider the possible or probable forms or contours of arches in the present Chapter, and in the succeeding one the forms of voussoir and other help which may best fortify these visible lines against every temptation to lose their consistency.

§ x. Look back to Fig. XXIX. Evidently the abstract or ghost line of the arrangement at A is a plain horizontal line, as here at *a*, Fig. XXX.

The abstract line of the arrangement at B, Fig. XXIX., is composed of two straight lines, set against each other, as here at *b*. The abstract line of C, Fig. XXIX., is a curve of some kind, not at present determined, suppose *c*, Fig. XXX.

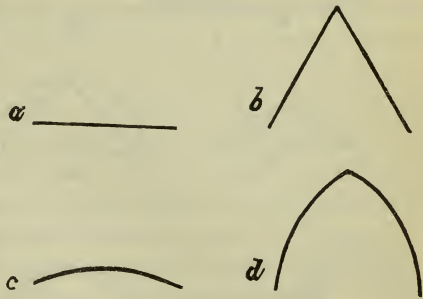

FIG. XXX.

Then, as *b* is two of the straight lines at *a*, set up against each other, we may conceive an arrangement, *d*, made up of two of the curved lines at *c*, set against each other. This is called a pointed arch, which is a contradiction in terms: it ought to be called a curved gable; but it must keep the name it has got.

Now *a*, *b*, *c*, *d*, Fig. XXX., are the ghosts of the lintel, the gable, the arch, and the pointed arch. With the poor lintel ghost we need trouble ourselves no farther; there are no changes in him: but there is much variety in the other three, and the method of their variety will be best discerned by studying *b* and *d*, as subordinate to and connected with the simple arch at *c*.

§ XI. Many architects, especially the worst, have been very curious in designing out of the way arches,—elliptical arches, and four-centred arches, so called, and other singularities. The good architects have generally been content, and we for the present will be so, with God's arch, the arch of the rainbow and of the apparent heaven, and which the sun shapes for us as it sets and rises. Let us watch the sun for a moment as it climbs : when it is a quarter up, it will give us the arch *a*, Fig. XXXI. ; when it is half up, *b*, and when three quarters

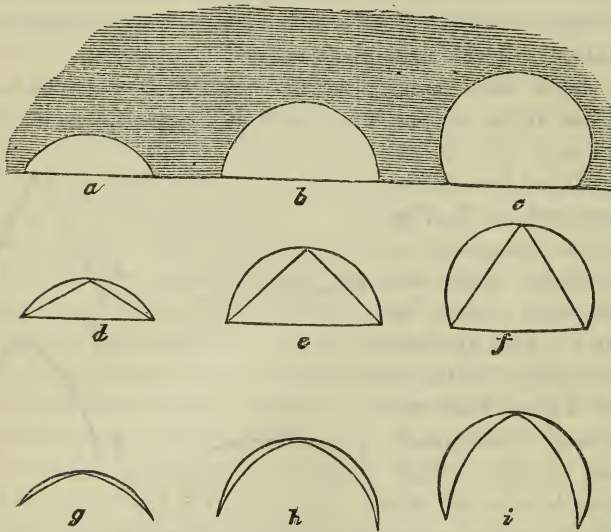

FIG. XXXI.

up, *c*. There will be an infinite number of arches between these, but we will take these as sufficient representatives of all. Then *a* is the low arch, *b* the central or pure arch, *c* the high arch, and the rays of the sun would have drawn for us their voussoirs.

§ XII. We will take these several arches successively, and fixing the top of each accurately, draw two right lines thence to its base, *d*, *e*, *f*, Fig. XXXI. Then these lines give us the relative gables of each of the arches ; *d* is the Italian or southern gable, *e* the central gable, *f* the Gothic gable.

§ xiii. We will again take the three arches with their gables in succession, and on each of the sides of the gable, between it and the arch, we will describe another arch, as at *g*, *h*, *i*. Then the curves so described give the pointed arches belonging to each of the round arches; *g*, the flat pointed arch, *h*, the central pointed arch, and *i*, the lancet pointed arch.

§ xiv. If the radius with which these intermediate curves are drawn be the base of *f*, the last is the equilateral pointed arch, one of great importance in Gothic work. But between the gable and circle, in all the three figures, there are an infinite number of pointed arches, describable with different radii; and the three round arches, be it remembered, are themselves representatives of an infinite number, passing from the flattest conceivable curve, through the semicircle and horseshoe, up to the full circle.

The central and the last group are the most important. The central round, or semicircle, is the Roman, the Byzantine, and Norman arch; and its relative pointed includes one wide branch of Gothic. The horseshoe round is the Arabic and Moorish arch, and its relative pointed includes the whole range of Arabic and lancet, or Early English and French Gothics. I mean of course by the relative pointed, the entire group of which the equilateral arch is the representative. Between it and the outer horseshoe, as this latter rises higher, the reader will find, on experiment, the great families of what may be called the horseshoe pointed,—curves of the highest importance, but which are all included, with English lancet, under the term, relative pointed of the horseshoe arch.



FIG. XXXII.

§ xv. The groups above described are all formed of circular arcs, and include all truly useful and beautiful arches for ordinary work. I believe that singular and complicated curves are made use of in modern engineering, but with these the general reader can have no concern: the Ponte della Trinita at Florence is the most graceful instance I know of such structure; the arch made use of being very subtle, and approximating to the low ellipse; for which, in common work,

a barbarous pointed arch, called four-centred, and composed of bits of circles, is substituted by the English builders. The high ellipse, I believe, exists in eastern architecture. I have never myself met with it on a large scale ; but it occurs in the niches of the later portions of the Ducal palace at Venice, together with a singular hyperbolic arch, *a* in Fig. XXXIII., to be described hereafter : with such caprices we are not here concerned.

§ XVI. We are, however, concerned to notice the absurdity of another form of arch, which, with the four-centred, belongs to the English perpendicular Gothic.

Taking the gable of any of the groups in Fig. XXXI. (suppose the equilateral), here at *b*, in Fig. XXXIII., the dotted



FIG. XXXIII.

line representing the relative pointed arch, we may evidently conceive an arch formed by reversed curves on the inside of the gable, as here shown by the inner curved lines. I imagine the reader by this time knows enough of the nature of arches to understand that, whatever strength or stability was gained by the curve on the *outside* of the gable, exactly so much is lost by curves on the *inside*. The natural tendency of such an arch to dissolution by its own mere weight renders it a feature of detestable ugliness, wherever it occurs on a large scale. It is eminently characteristic of Tudor work, and it is the profile of the Chinese roof (I say on a large scale, because this as well as all other capricious arches, may be made secure by their masonry when small, but not otherwise). Some allowable modifications of it will be noticed in the chapter on Roofs.

§ XVII. There is only one more form of arch which we have to notice. When the last described arch is used, not as the

principal arrangement, but as a mere heading to a common pointed arch, we have the form *c*, Fig. XXXIII. Now this is better than the entirely reversed arch for two reasons ; first, less of the line is weakened by reversing ; secondly, the double curve has a very high æsthetic value, not existing in the mere segments of circles. For these reasons arches of this kind are not only admissible, but even of great desirableness, when their scale and masonry render them secure, but above a certain scale they are altogether barbarous ; and, with the reversed Tudor arch, wantonly employed, are the characteristics of the worst and meanest schools of architecture, past or present.

This double curve is called the Ogee ; it is the profile of many German leaden roofs, of many Turkish domes (there more excusable, because associated and in sympathy with exquisitely managed arches of the same line in the walls below), of Tudor turrets, as in Henry the Seventh's Chapel, and it is at the bottom or top of sundry other blunders all over the world.

§ XVIII. The varieties of the ogee curve are infinite, as the reversed portion of it may be engrafted on every other form of arch, horseshoe, round, or pointed. Whatever is generally worth of note in these varieties, and in other arches of caprice, we shall best discover by examining their masonry ; for it is by their good masonry only that they are rendered either stable or beautiful. To this question, then, let us address ourselves.

CHAPTER XI.

THE ARCH MASONRY.

§ I. ON the subject of the stability of arches, volumes have been written and volumes more are required. The reader will not, therefore, expect from me any very complete explanation of its conditions within the limits of a single chapter. But that which is necessary for him to know is very simple and very easy ; and yet, I believe, some part of it is very little known, or noticed.

We must first have a clear idea of what is meant by an arch. It is a curved *shell* of firm materials, on whose back a burden is to be laid of *loose* materials. So far as the materials above it are *not loose*, but themselves hold together, the opening below is not an arch, but an *excavation*. Note this difference very carefully. If the King of Sardinia tunnels through the Mont Cenis, as he proposes, he will not require to build a brick arch under his tunnel to carry the weight of the Mont Cenis: that would need scientific masonry indeed. The Mont Cenis will carry itself, by its own cohesion, and a succession of invisible granite arches, rather larger than the tunnel. But when Mr. Brunel tunnelled the Thames bottom, he needed to build a brick arch to carry the six or seven feet of mud and the weight of water above. That is a type of all arches proper.

§ II. Now arches, in practice, partake of the nature of the two. So far as their masonry above is Mont-Cenisian, that is to say, colossal in comparison of them, and granitic, so that the arch is a mere hole in the rock substance of it, the form of the arch is of no consequence whatever: it may be rounded, or lozenged, or ogee'd, or anything else; and in the noblest architecture there is always *some* character of this kind given to the masonry. It is independent enough not to care about the holes cut in it, and does not subside into them like sand. But the theory of arches does not presume on any such condition of things; it allows itself only the shell of the arch proper; the vertebræ, carrying their marrow of resistance; and, above this shell, it assumes the wall to be in a state of flux, bearing down on the arch, like water or sand, with its whole weight. And farther, the problem which is to be solved by the arch builder is not merely to carry this weight, but to carry it with the least thickness of shell. It is easy to carry it by continually thickening your voussoirs: if you have six feet depth of sand or gravel to carry, and you choose to employ granite voussoirs six feet thick, no question but your arch is safe enough. But it is perhaps somewhat too costly. the thing to be done is to carry the sand or gravel with brick voussoirs, six inches thick, or, at any rate, with the least

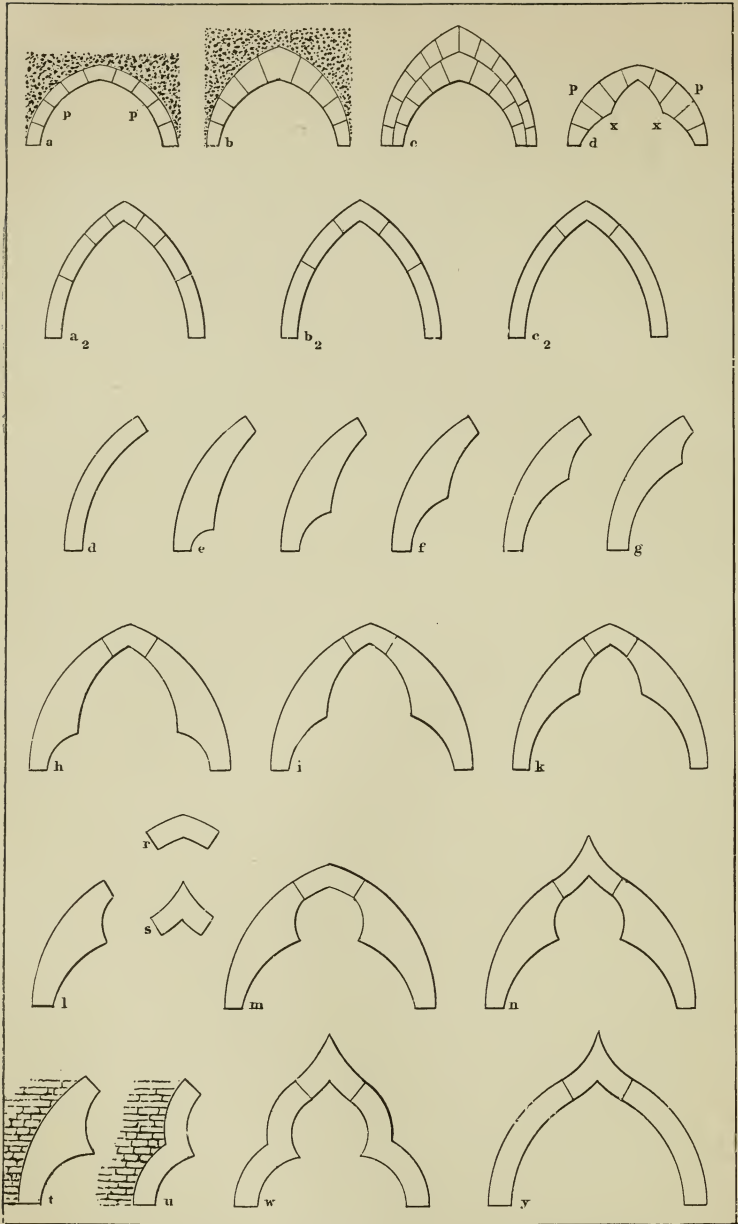

PLATE III.—ARCH MASONRY.

thickness of voussoir which will be safe ; and to do this requires peculiar arrangement of the lines of the arch. There are many arrangements, useful all in their way, but we have only to do, in the best architecture, with the simplest and most easily understood. We have first to note those which regard the actual shell of the arch, and then we shall give a few examples of the superseding of such expedients by Mont-Cenisian masonry.

§ III. What we have to say will apply to all arches, but the central pointed arch is the best for general illustration. Let *a*, Plate III., be the shell of a pointed arch with loose loading above ; and suppose you find that shell not quite thick enough ; and that the weight bears too heavily on the top of the arch, and is likely to break it in : you proceed to thicken your shell, but need you thicken it all equally ? Not so ; you would only waste your good voussoirs. If you have any common sense you will thicken it at the top, where a Mylodon's skull is thickened for the same purpose (and some human skulls, I fancy), as at *b*. The pebbles and gravel above will now shoot off it right and left, as the bullets do off a cuirassier's breastplate, and will have no chance of beating it in.

If still it be not strong enough, a farther addition may be made, as at *c*, now thickening the voussoirs a little at the base also. But as this may perhaps throw the arch inconveniently high, or occasion a waste of voussoirs at the top, we may employ another expedient.

§ IV. I imagine the reader's common sense, if not his previous knowledge, will enable him to understand that if the arch at *a*, Plate III., burst *in* at the top, it must burst *out* at the sides. Set up two pieces of pasteboard, edge to edge, and press them down with your hand, and you will see them bend out at the sides. Therefore, if you can keep the arch from starting out at the points *p*, *p*, it *cannot* curve in at the top, put what weight on it you will, unless by sheer crushing of the stones to fragments.

§ V. Now you may keep the arch from starting out at *p* by loading it at *p*, putting more weight upon it and against it at that point ; and this, in practice, is the way it is usually done.

But we assume at present that the weight above is sand or water, quite unmanageable, not to be directed to the points we choose; and in practice, it may sometimes happen that we cannot put weight upon the arch at *p*. We may perhaps want an opening above it, or it may be at the side of the building, and many other circumstances may occur to hinder us.

§ VI. But if we are not sure that we can put weight above it, we are perfectly sure that we can hang weight under it. You may always thicken your shell inside, and put the weight upon it as at *x x*, in *d*, Plate III. Not much chance of its bursting out at *p*, now, is there?

§ VII. Whenever, therefore, an arch has to bear vertical pressure, it will bear it better when its shell is shaped as at *b* or *d*, than as at *a*: *b* and *d* are, therefore, the types of arches built to resist vertical pressure, all over the world, and from the beginning of architecture to its end. None others can be compared with them: all are imperfect except these.

The added projections at *x x*, in *d*, are called *CUSPS*, and they are the very soul and life of the best northern Gothic; yet never thoroughly understood nor found in perfection, except in Italy, the northern builders working often, even in the best times, with the vulgar form at *a*.

The form at *b* is rarely found in the north: its perfection is in the Lombardic Gothic; and branches of it, good and bad according to their use, occur in Saracenic work.

§ VIII. The true and perfect cusp is single only. But it was probably invented (by the Arabs?) not as a constructive, but a decorative feature, in pure fantasy; and in early northern work it is only the application to the arch of the foliation, so called, of penetrated spaces in stone surfaces, already enough explained in the "Seven Lamps," Chap. III., p. 85 *et seq.* It is degraded in dignity, and loses its usefulness, exactly in proportion to its multiplication on the arch. In later architecture, especially English Tudor, it is sunk into dotage, and becomes a simple excrescence, a bit of stone pinched up out of the arch, as a cook pinches the paste at the edge of a pie.

§ IX. The depth and place of the cusp, that is to say, its

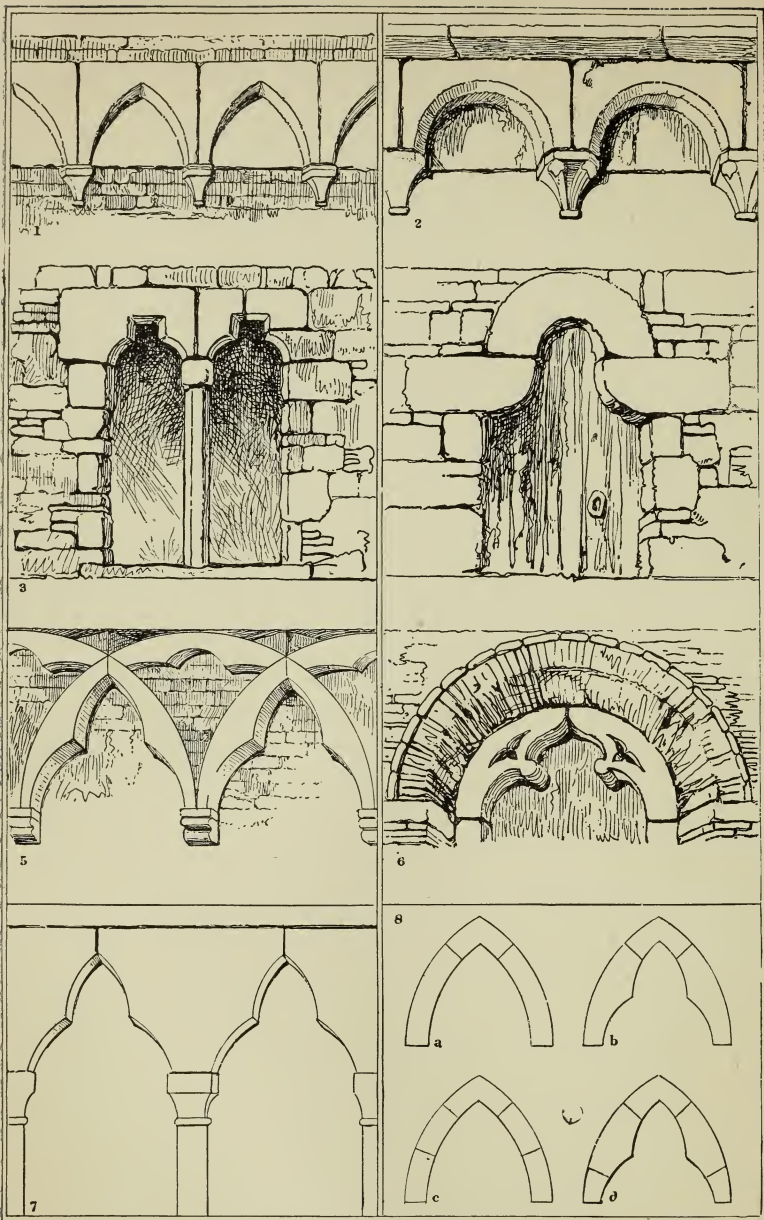

PLATE IV.—ARCH MASONRY.

exact application to the shoulder of the curve of the arch, varies with the direction of the weight to be sustained. I have spent more than a month, and that in hard work too, in merely trying to get the forms of cusps into perfect order: whereby the reader may guess that I have not space to go into the subject now; but I shall hereafter give a few of the leading and most perfect examples, with their measures and masonry.

§ x. The reader now understands all that he need about the shell of the arch, considered as an united piece of stone.

He has next to consider the shape of the voussoirs. This, as much as is required, he will be able best to comprehend by a few examples; by which I shall be able also to illustrate, or rather which will force me to illustrate, some of the methods of Mont-Cenisian masonry, which were to be the second part of our subject.

§ xi. 1 and 2, Plate IV., are two cornices; 1 from St. Antonio, Padua; 2, from the Cathedral of Sens. I want them for cornices; but I have put them in this plate because, though their arches are filled up behind, and are in fact mere blocks of stone with arches cut into their faces, they illustrate the constant masonry of small arches, both in Italian and Northern Romanesque, but especially Italian, each arch being cut out of its own proper block of stone: this is Mont-Cenisian enough, on a small scale.

3 is a window from Carnarvon Castle, and very primitive and interesting in manner,—one of its arches being of one stone, the other of two. And here we have an instance of a form of arch which would be barbarous enough on a large scale, and of many pieces; but quaint and agreeable thus massively built.

4 is from a little belfry in a Swiss village above Vevay; one fancies the window of an absurd form, seen in the distance, but one is pleased with it on seeing its masonry. It could hardly be stronger.

§ xii. These then are arches cut of one block. The next step is to form them of two pieces, set together at the head of the arch. 6, from the Eremitani, Padua, is very quaint and primitive in manner: it is a curious church altogether,

and has some strange traceries cut out of single blocks. One is given in the "Seven Lamps," Plate VII., in the left-hand corner at the bottom.

7, from the Frari, Venice, very firm and fine, and admirably decorated, as we shall see hereafter. 5, the simple two-pieced construction, wrought with the most exquisite proportion and precision of workmanship, as is everything else in the glorious church to which it belongs, San Fermo of Verona. The addition of the top piece, which completes the circle, does not affect the plan of the beautiful arches, with their simple and perfect cusps; but it is highly curious, and serves to show how the idea of the cusp rose out of mere foliation. The whole of the architecture of this church may be characterised as exhibiting the maxima of simplicity in construction, and perfection in workmanship,—a rare unison: for, in general, simple designs are rudely worked, and as the builder perfects his execution, he complicates his plan. Nearly all the arches of San Fermo are two-pieced.

§ XIII. We have seen the construction with one and two pieces: *a* and *b*, Fig. 8, Plate IV., are the general types of the construction with three pieces, uncusped and cusped; *c* and *d* with five pieces, uncusped and cusped. Of these the three-pieced construction is of enormous importance, and must detain us some time. The five-pieced is the three-pieced with a joint added on each side, and is also of great importance. The four-pieced, which is the two-pieced with added joints, rarely occurs, and need not detain us.

§ XIV. It will be remembered that in first working out the principle of the arch, we composed the arch of three pieces. Three is the smallest number which can exhibit the real *principle* of arch masonry, and it may be considered as representative of all arches built on that principle; the one and two-pieced arches being microscopic Mont-Cenisian, mere caves in blocks of stone, or gaps between two rocks leaning together.

But the three-pieced arch is properly representative of all; and the larger and more complicated constructions are merely produced by keeping the central piece for what is called a

keystone, and putting additional joints at the sides. Now so long as an arch is pure circular or pointed, it does not matter how many joints or voussoirs you have, nor where the joints are; nay, you may joint your keystone itself, and make it two-pieced. But if the arch be of any bizarre form, especially ogee, the joints must be in particular places, and the masonry simple, or it will not be thoroughly good and secure; and the fine schools of the ogee arch have only arisen in countries where it was the custom to build arches of few pieces.

§ xv. The typical pure pointed arch of Venice is a five-pieced arch, with its stones in three orders of magnitude, the longest being the lowest, as at b_2 , Plate III. If the arch be very large, a fourth order of magnitude is added, as at a_2 . The portals of the palaces of Venice have one or other of these masonries, almost without exception. Now, as one piece is added to make a larger door, one piece is taken away to make a smaller one, or a window, and the masonry type of the Venetian Gothic window is consequently three-pieced, c_2 .

§ xvi. The reader knows already where a cusp is useful. It is wanted, he will remember, to give weight to those side stones, and draw them inwards against the thrust of the top stone. Take one of the side stones of c_2 out for a moment, as at d . Now the *proper* place of the cusp upon it varies with the weight which it bears or requires; but in practice this nicety is rarely observed; the place of the cusp is almost always determined by æsthetic considerations, and it is evident that the variations in its place may be infinite. Consider the cusp as a wave passing up the side stone from its bottom to its top; then you will have the succession of forms from e , to g (Plate III.), with infinite degrees of transition from each to each; but of which you may take e , f , and g , as representing three great families of cusped arches. Use e for your side stones, and you have an arch as that at h below, which may be called a down-cusped arch. Use f for the side stone, and you have i , which may be called a mid-cusped arch. Use g , and you have k , an up-cusped arch.

§ xvii. The reader will observe that I call the arch mid-

cusped, not when the cusped point is in the middle of the curve of the arch, but when it is in the middle of the *side piece*, and also that where the side pieces join the keystone there will be a change, perhaps somewhat abrupt, in the curvature.

I have preferred to call the arch mid-cusped with respect to its side piece than with respect to its own curve, because the most beautiful Gothic arches in the world, those of the Lombard Gothic, have, in all the instances I have examined, a form more or less approximating to this mid-cusped one at *i* (Plate III.), but having the curvature of the cusp carried up into the keystone, as we shall see presently: where, however, the arch is built of many voussoirs, a mid-cusped arch will mean one which has the point of the cusp midway between its own base and apex.

The Gothic arch of Venice is almost invariably up-cusped as at *k*. The reader may note that, in both down-cusped and up-cusped arches, the piece of stone, added to form the cusp, is of the shape of a scymitar, held down in the one case and up in the other.

§ XVIII. Now, in the arches *h*, *i*, *k*, a slight modification has been made in the form of the central piece, in order that it may continue the curve of the cusp. This modification is not to be given to it in practice without considerable nicety of workmanship; and some curious results took place in Venice from this difficulty.

At *l* (Plate III.) is the shape of the Venetian side stone, with its cusp detached from the arch. Nothing can possibly be better or more graceful, or have the weight better disposed in order to cause it to nod forwards against the keystone, as above explained, Ch. X. § II., where I developed the whole system of the arch from three pieces, in order that the reader might now clearly see the use of the weight of the cusp.

Now a Venetian Gothic palace has usually at least three stories; with perhaps ten or twelve windows in each story, and this on two or three of its sides, requiring altogether some hundred to a hundred and fifty side pieces.

I have no doubt, from observation of the way the windows

are set together, that the side pieces were carved in pairs, like hooks, of which the keystones were to be the eyes; that these side pieces were ordered by the architect in the gross, and were used by him sometimes for wider, sometimes for narrower windows; bevelling the two ends as required, fitting in keystones as he best could, and now and then varying the arrangement by turning the side pieces *upside down*.

There were various conveniences in this way of working; one of the principal being that the side pieces with their cusps were always cut to their complete form, and that no part of the cusp was carried out into the keystone, which followed the curve of the outer arch itself. The ornaments of the cusp might thus be worked without any troublesome reference to the rest of the arch.

§ XIX. Now let us take a pair of side pieces, made to order, like that at *l*, and see what we can make of them. We will try to fit them first with a keystone which continues the curve of the outer arch, as at *m*. This the reader assuredly thinks an ugly arch. There are a great many of them in Venice, the ugliest things there, and the Venetian builders quickly began to feel them so. What could they do to better them? The arch at *m* has a central piece of the form *r*. Substitute for it a piece of the form *s*, and we have the arch at *n*.

§ XX. This arch at *n* is not so strong as that at *m*; but, built of good marble, and with its pieces of proper thickness, it is quite strong enough for all practical purposes on a small scale. I have examined at least two thousand windows of this kind and of the other Venetian ogees, of which that at *y* (in which the plain side-piece *d* is used instead of the cusped one) is the simplest; and I never found *one*, even in the most ruinous palaces (in which they had had to sustain the distorted weight of falling walls) in which the central piece was fissured; and this is the only danger to which the window is exposed; in other respects it is as strong an arch as can be built.

It is not to be supposed that the change from the *r* keystone to the *s* keystone was instantaneous. It was a change wrought

out by many curious experiments, which we shall have to trace hereafter, and to throw the resultant varieties of form into their proper groups.

§ XXI. One step more: I take a mid-cusped side piece in its block form at *t*, with the bricks which load the back of it. Now, as these bricks support it behind, and since, as far as the use of the cusp is concerned, it matters not whether its weight be in marble or bricks, there is nothing to hinder us from cutting out some of the marble, as at *u*, and filling up the space with bricks. (*Why* we should take a fancy to do this, I do not pretend to guess at present; all I have to assert is, that, if the fancy should strike us, there would be no harm in it). Substituting this side piece for the other in the window *n*, we have that at *w*, which may, perhaps, be of some service to us afterwards; here we have nothing more to do with it than to note that, thus built, and properly backed by brickwork, it is just as strong and safe a form as that at *n*; but that this, as well as every variety of ogee arch, depends entirely for its safety, fitness, and beauty, on the masonry which we have just analysed; and that, built on a large scale, and with many voussoirs, all such arches would be unsafe and absurd in general architecture. Yet they may be used occasionally for the sake of the exquisite beauty of which their rich and fantastic varieties admit, and sometimes for the sake of another merit, exactly the opposite of the constructional ones we are at present examining, that they seem to stand by enchantment.

§ XXII. In the above reasonings, the inclination of the joints of the voussoirs to the curves of the arch has not been considered. It is a question of much nicety, and which I have not been able as yet fully to investigate: but the natural idea of the arrangement of these lines (which in round arches are of course perpendicular to the curve) would be that every voussoir should have the lengths of its outer and inner arched surface in the same proportion to each other. Either this actual law, or a close approximation to it, is assuredly enforced in the best Gothic buildings.

§ XXIII. I may sum up all that it is necessary for the reader



I. Puskar.

T. S. Boys

Arch Misanry.

BROLETTO OF COMO.

to keep in mind of the general laws connected with this subject, by giving him an example of each of the two forms of the perfect Gothic arch, uncusped and cusped, treated with the most simple and magnificent masonry, and partly, in both cases, Mont-Cenisian.

The first, Plate V., is a window from the Broletto of Como. It shows, in its filling, first, the single-pieced arch, carried on groups of four shafts, and a single slab of marble filling the space above, and pierced with a quatrefoil (Mont-Cenisian, this), while the mouldings above are each constructed with a separate system of voussoirs, all of them shaped, I think, on the principle above stated, § xxii., in alternate serpentine and marble; the outer arch being a noble example of the pure uncusped Gothic construction, *b* of Plate III.

§ xxiv. Fig. XXXIV. is the masonry of the side arch of, as far as I know or am able to judge, the most perfect Gothic sepulchral monument in the world, the foursquare canopy of the (nameless ?) * tomb standing over the small cemetery gate of the Church of St. Anastasia at Verona. I shall have frequent occasion to recur to this monument, and, I believe, shall be able sufficiently to justify the terms in which I speak of it: meanwhile, I desire only that the reader should observe the severity and simplicity of the arch lines, the exquisitely delicate suggestion of the ogee curve in the apex, and chiefly the use of the cusp in giving *inward* weight to the great pieces of stone on the flanks of the arch, and preventing their thrust outwards from being severely thrown on the lowermost stones. The effect of this arrangement is, that the whole massy canopy is sustained safely by four slender pillars (as will be seen hereafter in the careful plate I hope to give of it), these pillars being rather steadied than materially assisted against the thrust, by iron bars, about an inch thick, connecting them at the heads of the abaci; a feature of peculiar importance in this monument, inasmuch as we know it to be part of the

* At least I cannot find any account of it in Maffei's "Verona," nor anywhere else, to be depended upon. It is, I doubt not, a work of the beginning of the thirteenth century. Vide Appendix 19, "Tombs at St. Anastasia."

original construction, by a beautiful little Gothic wreathed pattern, like one of the hems of garments of Fra Angelico, running along the iron bar itself. So carefully, and so far, is

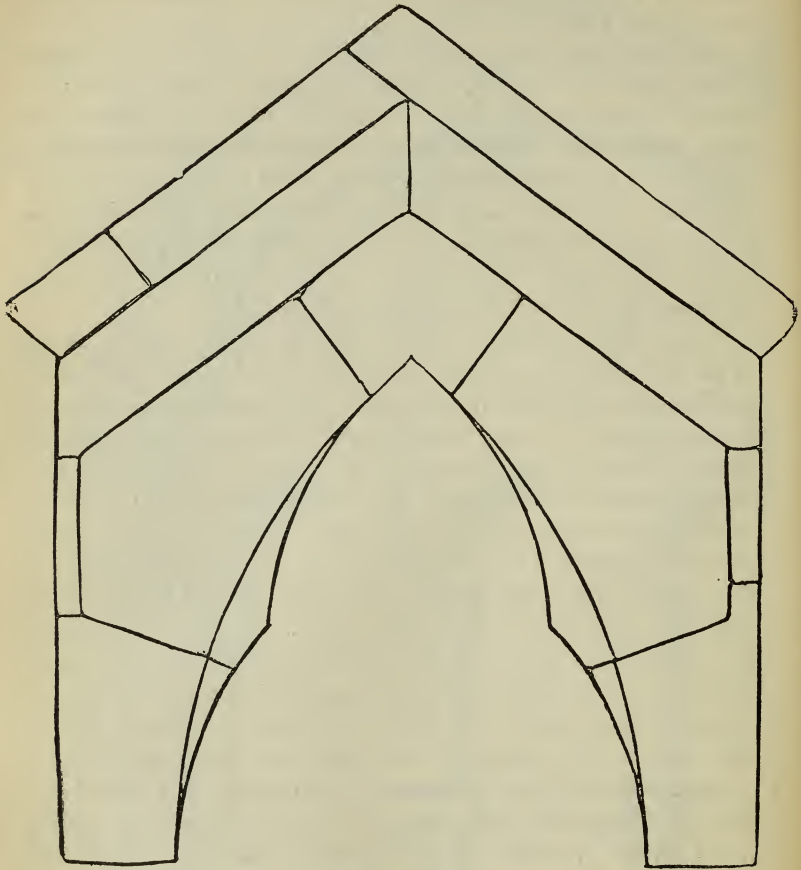

FIG. XXXIV.

the system of decoration carried out in this pure and lovely monument, my most beloved throughout all the length and breadth of Italy ; --chief, as I think, among all the sepulchral marbles of a land of mourning.

CHAPTER XII.

THE ARCH LOAD.

§ I. IN the preceding enquiry we have always supposed either that the load upon the arch was perfectly loose, as of gravel or sand, or that it was Mont-Cenisian, and formed one mass with the arch voussoirs, of more or less compactness.

In practice, the state is usually something between the two. Over bridges and tunnels it sometimes approaches to the condition of mere dust or yielding earth; but in architecture it is mostly firm masonry, not altogether acting with the voussoirs, yet by no means bearing on them with perfectly dead weight, but locking itself together above them, and capable of being thrown into forms which relieve them, in some degree, from its pressure.

§ II. It is evident that if we are to place a continuous roof above the line of arches, we must fill up the intervals between them on the tops of the columns. We have at present nothing granted us

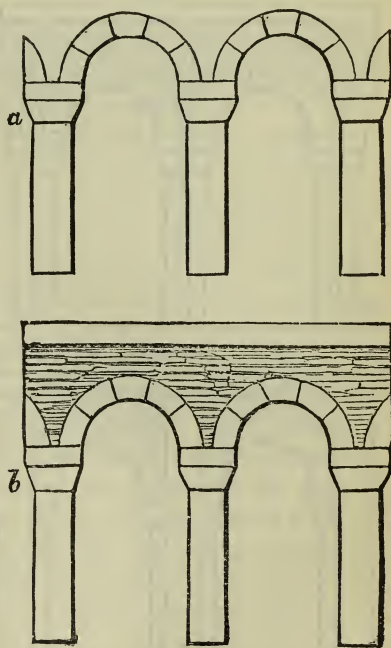

FIG. XXXV.

but the bare masonry, as here at *a*, Fig. XXXV., and we must fill up the intervals between the semicircle so as to obtain a level line of support. We may first do this simply as at *b*, with plain mass of wall; so laying the roof on the top, which is the method of the pure Byzantine and Italian Roman-

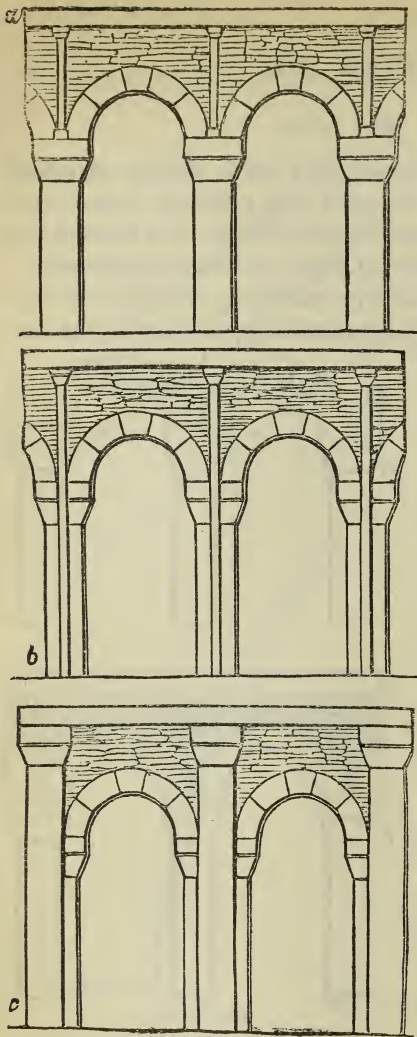

FIG. XXXVI.

part of the group, the principle is Romanesque or Gothic, *b*, Fig. XXXVI. When it becomes a bold central shaft, and the main pier splits into two minor shafts on its sides, the principle is Classical or Palladian, *c*, Fig. XXXVI. Which

esque. But if we find too much stress is thus laid on the arches, we may introduce small second shafts on the top of the great shaft, *a*, Fig. XXXVI, which may assist in carrying the roof, conveying great part of its weight at once to the heads of the main shafts, and relieving from its pressure the centres of the arches.

§ III. The new shaft thus introduced may either remain lifted on the head of the great shaft, or may be carried to the ground in front of it, or through it, *b*, Fig. XXXVI; in which latter case the main shaft divides into two or more minor shafts, and forms a group with the shaft brought down from above.

§ IV. When this shaft, brought from roof to ground, is subordinate to the main pier, and either is carried down the face of it, or forms no large

latter arrangement becomes absurd or unsatisfactory in proportion to the sufficiency of the main shaft to carry the roof without the help of the minor shafts or arch, which in many instances of Palladian work look as if they might be removed without danger to the building.

§ v. The form *a* is a more pure Northern Gothic type than even *b*, which is the connecting link between it and the classical type. It is found chiefly in English and other northern Gothic, and in early Lombardic, and is, I doubt not, derived as above explained, Chap. I. § xxvii. *b* is a general French Gothic and French Romanesque form, as in great purity at Valence.

The small shafts of the form *a* and *b*, as being northern, are generally connected with steep vaulted roofs, and receive for that reason the name of vaulting shafts.

§ vi. Of these forms *b*, Fig. XXXV., is the purest and most sublime, expressing the power of the arch most distinctly. All the others have some appearance of dovetailing and morticing of timber rather than stonework; nor have I ever yet seen a single instance, quite satisfactory, of the management of the capital of the main shaft, when it had either to sustain the base of the vaulting shaft, as in *a*, or to suffer it to pass through it, as in *b*, Fig. XXXVI. Nor is the bracket which frequently carries the vaulting shaft in English work a fitting support for a portion of the fabric which is at all events presumed to carry a considerable part of the weight of the roof.

§ vii. The triangular spaces on the flanks of the arch are called Spandrels, and if the masonry of these should be found, in any of its forms, too heavy for the arch, their weight may be diminished, while their strength remains the same, by piercing them with circular holes or lights. This is rarely necessary in ordinary architecture, though sometimes of great use in bridges and iron roofs (a succession of such circles may be seen, for instance, in the spandrels at the Euston Square station); but, from its constructional value, it becomes the best form in which to arrange spandril decorations, as we shall see hereafter.

§ viii. The height of the load above the arch is determined

by the needs of the building and possible length of the shaft; but with this we have at present nothing to do, for we have performed the task which was set us. We have ascertained, as it was required that we should in § VI. of Chap. III. (A), the construction of walls; (B), that of piers; (C), that of piers with lintels or arches prepared for roofing. We have next, therefore, to examine (D) the structure of the roof.

CHAPTER XIII.

THE ROOF.

§ I. HITHERTO our enquiry has been unembarrassed by any considerations relating exclusively either to the exterior or interior of buildings. But it can remain so no longer. As far as the architect is concerned, one side of a wall is generally the same as another; but in the roof there are usually two distinct divisions of the structure; one, a shell, vault, or flat ceiling, internally visible, the other, an upper structure, built of timber, to protect the lower; or of some different form, to support it. Sometimes, indeed, the internally visible structure is the real roof, and sometimes there are more than two divisions, as in St. Paul's, where we have a central shell with a mask below and above. Still it will be convenient to remember the distinction between the part of the roof which is usually visible from within, and whose only business is to stand strongly, and not fall in, which I shall call the Roof Proper; and, secondly, the upper roof, which, being often partly supported by the lower, is not so much concerned with its own stability as with the weather, and is appointed to throw off snow, and get rid of rain, as fast as possible, which I shall call the Roof Mask.

§ II. It is, however, needless for me to engage the reader in the discussion of the various methods of construction of Roofs Proper, for this simple reason, that no person without long experience can tell whether a roof be wisely constructed or not; nor tell at all, even with help of any amount of expe-

rience, without examination of the several parts and bearings of it, very different from any observation possible to the general critic : and more than this, the enquiry would be useless to us in our Venetian studies, where the roofs are either not contemporary with the buildings, or flat, or else vaults of the simplest possible constructions, which have been admirably explained by Willis in his "Architecture of the Middle Ages," Chap. VII., to which I may refer the reader for all that it would be well for him to know respecting the connexion of the different parts of the vault with the shafts. He would also do well to read the passages on Tudor vaulting, pp. 185-193, in Mr. Garbett's rudimentary Treatise on Design, before alluded to.* I shall content myself therefore with noting one or two points on which neither writer has had occasion to touch, respecting the Roof Mask.

§ III. It was said in § v. of Chapter III. that we should not have occasion, in speaking of roof construction, to add materially to the forms then suggested. The forms which we have to add are only those resulting from the other curves of the arch developed in the last chapter ; that is to say, the various eastern domes and cupolas arising out of the revolution of the horseshoe and ogee curves, together with the well-known Chinese concave roof. All these forms are of course purely decorative, the bulging outline, or concave surface, being of no more use, or rather of less, in throwing off snow or rain, than the ordinary spire and gable ; and it is rather curious, therefore, that all of them, on a small scale, should have obtained so extensive use in Germany and Switzerland, their native climate being that of the east, where their purpose seems rather to concentrate light upon their orbed surfaces. I much doubt their applicability, on a large scale, to architecture of any admirable dignity ; their chief charm is, to the European eye, that of strangeness ; and it seems to me possible that in the east the bulging form may be also delightful, from the idea of its enclosing a volume of cool air. I enjoy them in St. Mark's, chiefly because they increase the fantastic and unreal character of St. Mark's Place ; and be-

* Appendix 17.

cause they appear to sympathise with an expression, common, I think, to all the buildings of that group, of a natural buoyancy, as if they floated in the air or on the surface of the sea. But, assuredly, they are not features to be recommended for imitation.*

§ iv. One form, closely connected with the Chinese concave, is, however, often constructively right,—the gable with an inward angle, occurring with exquisitely picturesque effect throughout the domestic architecture of the north, especially Germany and Switzerland; the lower slope being either an attached external penthouse roof, for protection of the wall, as in Fig. XXXVII., or else a kind of buttress set on the angle of the tower; and in either case the roof itself being a simple gable, continuous beneath it.



FIG. XXXVII.

§ v. The true gable, as it is the simplest and most natural, so I esteem it the grandest of roofs; whether rising in ridgy darkness, like a grey slope of slaty mountains, over the precipitous walls of the northern cathedrals, or stretched in burning breadth above the white and square-set groups of the southern architecture. But this difference between its slope in the northern and southern structure is a matter of far greater importance than is commonly supposed, and it is this to which I would especially direct the reader's attention.

§ vi. One main cause of it, the necessity of throwing off

* I do not speak of the true dome, because I have not studied its construction enough to know at what largeness of scale it begins to be rather a *tour de force* than a convenient or natural form of roof, and because the ordinary spectator's choice among its various outlines must always be dependent on æsthetic considerations only, and can in no wise be grounded on any conception of its infinitely complicated structural principles.

snow in the north, has been a thousand times alluded to: another I do not remember having seen noticed, namely, that rooms in a roof are comfortably habitable in the north, which are painful *sotto piombi* in Italy; and that there is in wet climates a natural tendency in all men to live as high as possible, out of the damp and mist. These two causes, together with accessible quantities of good timber, have induced in the north a general steep pitch of gable, which, when rounded or squared above a tower, becomes a spire or turret; and this feature, worked out with elaborate decoration, is the key-note of the whole system of aspiration, so called, which the German critics have so ingeniously and falsely ascribed to a devotional sentiment pervading the Northern Gothic: I entirely and boldly deny the whole theory; our cathedrals were for the most part built by worldly people, who loved the world, and would have gladly staid in it for ever; whose best hope was the escaping hell, which they thought to do by building cathedrals, but who had very vague conceptions of Heaven in general, and very feeble desires respecting their entrance therein; and the form of the spired cathedral has no more intentional reference to Heaven, as distinguished from the flattened slope of the Greek pediment, than the steep gable of a Norman house has, as distinguished from the flat roof of a Syrian one. We may now, with ingenious pleasure, trace such symbolic characters in the form; we may now use it with such definite meaning; but we only prevent ourselves from all right understanding of history, by attributing much influence to these poetical symbolisms in the formation of a national style. The human race are, for the most part, not to be moved by such silken cords; and the chances of damp in the cellar, or of loose tiles in the roof, have, unhappily, much more to do with the fashions of a man's house building than his ideas of celestial happiness or angelic virtue. Associations of affection have far higher power, and forms which can be no otherwise accounted for may often be explained by reference to the natural features of the country, or to anything which habit must have rendered familiar, and therefore delightful; but the direct symbolisation of a sentiment is a

weak motive with all men, and far more so in the practical minds of the north than among the early Christians, who were assuredly quite as heavenly-minded, when they built basilicas, or cut conchas out of the catacombs, as were ever the Norman barons or monks.

§ VII. There is, however, in the north an animal activity which materially aided the system of building begun in mere utility,—an animal life, naturally expressed in erect work, as the languor of the south in reclining or level work. Imagine the difference between the action of a man urging himself to his work in a snow storm, and the inaction of one laid at his length on a sunny bank among cicadas and fallen olives, and you will have the key to a whole group of sympathies which were forcefully expressed in the architecture of both; remembering always that sleep would be to the one luxury, to the other death.

§ VIII. And to the force of this vital instinct we have farther to add the influence of natural scenery; and chiefly of the groups and wildernesses of the tree which is to the German mind what the olive or palm is to the southern, the spruce fir. The eye which has once been habituated to the continual seriation of the pine forest, and to the multiplication of its infinite pinnacles, is not easily offended by the repetition of similar forms, nor easily satisfied by the simplicity of flat or massive outlines. Add to the influence of the pine, that of the poplar, more especially in the valleys of France; but think of the spruce chiefly, and meditate on the difference of feeling with which the Northman would be inspired by the frost-work wreathed upon its glittering point, and the Italian by the dark green depth of sunshine on the broad table of the stone-pine* (and consider by the way whether the spruce fir be a more

* I shall not be thought to have overrated the effect of forest scenery on the *northern* mind; but I was glad to hear a Spanish gentleman, the other day, describing, together with his own, the regret which the peasants in his neighborhood had testified for the loss of a noble stone-pine, one of the grandest in Spain, which its proprietor had suffered to be cut down for small gain. He said that the mere spot where it had grown was still popularly known as "El Pino."

heavenly-minded tree than those dark canopies of the Mediterranean isles).

§ IX. Circumstance and sentiment, therefore, aiding each other, the steep roof becomes generally adopted, and delighted in, throughout the north; and then, with the gradual exaggeration with which every pleasant idea is pursued by the human mind, it is raised into all manner of peaks, and points, and ridges; and pinnacle after pinnacle is added on its flanks, and the walls increased in height, in proportion, until we get indeed a very sublime mass, but one which has no more principle of religious aspiration in it than a child's tower of cards. What is more, the desire to build high is complicated with the peculiar love of the grotesque* which is characteristic of the north, together with especial delight in multiplication of small forms as well as in exaggerated points of shade and energy, and a certain degree of consequent insensibility to perfect grace and quiet truthfulness; so that a northern architect could not feel the beauty of the Elgin marbles, and there will always be (in those who have devoted themselves to this particular school) a certain incapacity to taste the finer characters of Greek art, or to understand Titian, Tintoret, or Raphael: whereas among the Italian Gothic workmen, this capacity was never lost, and Nino Pisano and Orcagna could have understood the Theseus in an instant, and would have received from it new life. There can be no question that theirs was the greatest school, and carried out by the greatest men; and that while those who began with this school could perfectly well feel Rouen Cathedral, those who study the Northern Gothic remain in a narrowed field—one of small pinnacles, and dots, and crockets, and twitched faces—and cannot comprehend the meaning of a broad surface or a grand line. Nevertheless the northern school is an admirable and delightful thing, but a lower thing than the southern. The Gothic of the Ducal Palace of Venice is in harmony with all that is grand in all the world: that of the north is in harmony with the grotesque northern spirit only.

§ X. We are, however, beginning to lose sight of our roof

* Appendix 8.

structure in its spirit, and must return to our text. As the height of the walls increased, in sympathy with the rise of the roof, while their thickness remained the same, it became more and more necessary to support them by buttresses ; but—and this is another point that the reader must specially note—it is not the steep roof mask which requires the buttress, but the vaulting beneath it ; the roof mask being a mere wooden frame tied together by cross timbers, and in small buildings often put together on the ground, raised afterwards, and set on the walls like a hat, bearing vertically upon them ; and farther, I believe in most cases the northern vaulting requires its great array of external buttress, not so much from any peculiar boldness in its own forms, as from the greater comparative thinness and height of the walls, and more determined throwing of the whole weight of the roof on particular points. Now the connexion of the interior frame-work (or true roof) with the buttress, at such points, is not visible to the spectators from without ; but the relation of the roof mask to the top of the wall which it protects, or from which it springs, is perfectly visible ; and it is a point of so great importance in the effect of the building, that it will be well to make it a subject of distinct consideration in the following Chapter.

CHAPTER XIV.

THE ROOF CORNICE.

§ I. IT will be remembered that in the Sixth Chapter we paused (§ x.) at the point where the addition of brackets to the ordinary wall cornice would have converted it into a structure proper for sustaining a roof. Now the wall cornice was treated throughout our enquiry (compare Chapter VII. § v.) as the capital of the wall, and as forming, by its concentration, the capital of the shaft. But we must not reason *back* from the capital to the cornice, and suppose that an extension of the principles of the capital to the whole length of the wall, will serve for the roof cornice ; for all our conclu-

sions respecting the capital were based on the supposition of its being adapted to carry considerable weight condensed on its abacus: but the roof cornice is, in most cases, required rather to project boldly than to carry weight; and arrangements are therefore to be adopted for it which will secure the projection of large surfaces without being calculated to resist extraordinary pressure. This object is obtained by the use of brackets at intervals, which are the peculiar distinction of the roof cornice.

§ II. Roof cornices are generally to be divided into two great families: the first and simplest, those which are composed merely by the projection of the edge of the roof mask over the wall, sustained by such brackets or spurs as may be necessary; the second, those which provide a walk round the edge of the roof, and which require, therefore, some stronger support, as well as a considerable mass of building above or beside the roof mask, and a parapet. These two families we shall consider in succession.

§ III. 1. The Eaved Cornice. We may give it this name, as represented in the simplest form by cottage eaves. It is used, however, in bold projection, both in north, and south, and east; its use being, in the north, to throw the rain well away from the wall of the building; in the south to give it shade; and it is ordinarily constructed of the ends of the timbers of the roof mask (with their tiles or shingles continued to the edge of the cornice), and sustained by spurs of timber. This is its most picturesque and natural form; not inconsistent with great splendor of architecture in the mediæval Italian domestic buildings, superb in its mass of cast shadow, and giving rich effect to the streets of Swiss towns, even when they have no other claim to interest. A farther value is given to it by its waterspouts, for in order to avoid loading it with weight of water in the gutter at the edge, where it would be a strain on the fastenings of the pipe, it has spouts of discharge at intervals of three or four feet,—rows of magnificent leaden or iron dragons' heads, full of delightful character, except to any person passing along the middle of the street in a heavy shower. I have had my share

of their kindness in my time, but owe them no grudge ; on the contrary, much gratitude for the delight of their fantastic outline on the calm blue sky, when they had no work to do but to open their iron mouths and pant in the sunshine.

§ iv. When, however, light is more valuable than shadow, or when the architecture of the wall is too fair to be concealed, it becomes necessary to draw the cornice into narrower limits ; a change of considerable importance, in that it permits the gutter, instead of being of lead and hung to the edge of the cornice, to be of stone, and supported by brackets in the wall, these brackets becoming proper recipients of after-decoration (and sometimes associated with the stone channels of discharge, called gargoyles, which belong, however, more properly to the other family of cornices). The most perfect and beautiful example of this kind of cornice is the Venetian, in which the rain from the tiles is received in a stone gutter supported by small brackets, delicately moulded, and having its outer lower edge decorated with the English dogtooth moulding, whose sharp zigzag mingles richly with the curved edges of the tiling. I know no cornice more beautiful in its extreme simplicity and serviceableness.

§ v. The cornice of the Greek Doric is a condition of the same kind, in which, however, there are no brackets, but useless appendages hung to the bottom of the gutter (giving, however, some impression of support as seen from a distance), and decorated with stone symbolisms of raindrops. The brackets are not allowed, because they would interfere with the sculpture, which in this architecture is put beneath the cornice ; and the overhanging form of the gutter is nothing more than a vast dripstone moulding, to keep the rain from such sculpture : its decoration of guttæ, seen in silver points against the shadow, is pretty in feeling, with a kind of continual refreshment and remembrance of rain in it ; but the whole arrangement is awkward and meagre, and is only endurable when the eye is quickly drawn away from it to sculpture.

§ vi. In later cornices, invented for the Greek orders, and farther developed by the Romans, the bracket appears in true

importance, though of barbarous and effeminate outline : and gorgeous decorations are applied to it, and to the various horizontal mouldings which it carries, some of them of great beauty, and of the highest value to the mediæval architects who imitated them. But a singularly gross mistake was made in the distribution of decoration on these rich cornices (I do not know when first, nor does it matter to me or to the reader), namely, the charging with ornament the under surface of the cornice between the brackets, that is to say, the exact piece of the whole edifice, from top to bottom, where ornament is least visible. I need hardly say much respecting the wisdom of this procedure, excusable only if the whole building were covered with ornament ; but it is curious to see the way in which modern architects have copied it, even when they had little enough ornament to spare. For instance, I suppose few persons look at the Athenæum Club-house without feeling vexed at the meagreness and meanness of the windows of the ground floor : if, however, they look up under the cornice, and have good eyes, they will perceive that the architect has reserved his decorations to put between the brackets ; and by going up to the first floor, and out on the gallery, they may succeed in obtaining some glimpses of the designs of the said decorations.

§ VII. Such as they are, or were, these cornices were soon considered essential parts of the "order" to which they belonged ; and the same wisdom which endeavored to fix the proportions of the orders, appointed also that no order should go without its cornice. The reader has probably heard of the architectural division of superstructure into architrave, frieze, and cornice ; parts which have been appointed by great architects to all their work, in the same spirit in which great rhetoricians have ordained that every speech shall have an exordium, and narration, and peroration. The reader will do well to consider that it may be sometimes just as possible to carry a roof, and get rid of rain, without such an arrangement, as it is to tell a plain fact without an exordium or peroration ; but he must very absolutely consider that the architectural peroration or cornice is strictly and sternly

limited to the end of the wall's speech,—that is, to the edge of the roof; and that it has nothing whatever to do with shafts nor the orders of them. And he will then be able fully to enjoy the farther ordinance of the late Roman and Renaissance architects, who, attaching it to the shaft as if it were part of its shadow, and having to employ their shafts often in places where they came not near the roof, forthwith cut the roof-cornice to pieces and attached a bit of it to every column; thenceforward to be carried by the unhappy shaft wherever it went, in addition to any other work on which it might happen to be employed. I do not recollect among any living beings, except Renaissance architects, any instance of a parallel or comparable stupidity: but one can imagine a savage getting hold of a piece of one of our iron wire ropes, with its rings upon it at intervals to bind it together, and pulling the wires asunder to apply them to separate purposes; but imagining there was magic in the ring that bound them, and so cutting that to pieces also, and fastening a little bit of it to every wire.

§ VIII. Thus much may serve us to know respecting the first family of wall cornices. The second is immeasurably more important, and includes the cornices of all the best buildings in the world. It has derived its best form from mediæval military architecture, which imperatively required two things; first, a parapet which should permit sight and offence, and afford defence at the same time; and secondly, a projection bold enough to enable the defenders to rake the bottom of the wall with falling bodies; projection which, if the wall happened to slope inwards, required not to be small. The thoroughly magnificent forms of cornice thus developed by necessity in military buildings, were adopted, with more or less of boldness or distinctness, in domestic architecture, according to the temper of the times and the circumstances of the individual—decisively in the baron's house, imperfectly in the burgher's: gradually they found their way into ecclesiastical architecture, under wise modifications in the early cathedrals, with infinite absurdity in the imitations of them; diminishing in size as their original purpose sank into a decorative

one, until we find battlements, two-and-a-quarter inches square, decorating the gates of the Philanthropic Society.

§ ix. There are, therefore, two distinct features in all cornices of this kind : first, the bracket, now become of enormous importance and of most serious practical service ; the second, the parapet : and these two features we shall consider in succession, and in so doing, shall learn all that is needful for us to know, not only respecting cornices, but respecting brackets in general, and balconies.

§ x. 1. The Bracket. In the simplest form of military cornice, the brackets are composed of two or more long stones, supporting each other in gradually increasing projection, with roughly rounded ends, Fig. XXXVIII., and the parapet is simply a low wall carried on the ends of these, leaving, of course, behind, or within it, a hole between each bracket for the convenient dejection of hot sand and lead. This form is best seen, I think, in the old Scotch castles ; it is very grand, but has a giddy look, and one is afraid of the whole thing toppling off the wall. The next step was to deepen the brackets, so as to get them propped against a great depth of the main rampart, and to have the inner ends of the stones held by a greater weight of that main wall above ; while small arches were thrown from bracket to bracket to carry the parapet wall more securely. This is the most perfect form of cornice, completely satisfying the eye of its security, giving full protection to the wall, and applicable to all architecture, the interstices between the brackets being filled up, when one does not want to throw boiling lead on any body below, and the projection being always delightful, as giving greater command and view of the building, from its angles, to those walking on the rampart. And as, in military buildings, there were usually towers at the angles (round which the battlements swept) in order to flank the walls, so often in the translation into civil or ecclesiastical architecture, a small turret remained

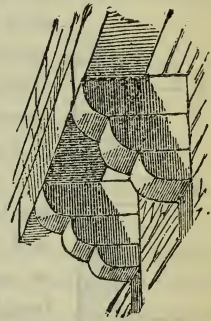

FIG. XXXVIII.

at the angle, or a more bold projection of balcony, to give larger prospect to those upon the rampart. This cornice, perfect in all its parts, as arranged for ecclesiastical architecture, and exquisitely decorated, is the one employed in the duomo of Florence and campanile of Giotto, of which I have already spoken as, I suppose, the most perfect architecture in the world.

§ XI. In less important positions and on smaller edifices, this cornice diminishes in size, while it retains its arrangement, and at last we find nothing but the spirit and form of it left; the real practical purpose having ceased, and arch, brackets and all, being cut out of a single stone. Thus we find it used in early buildings throughout the whole of the north and south of Europe, in forms sufficiently represented by the two examples in Plate IV. : 1, from St. Antonio, Padua; 2, from Sens, in France.

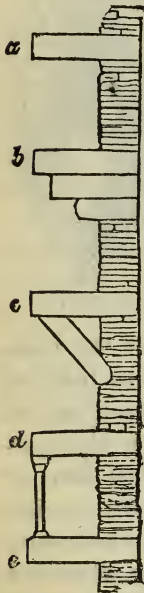

FIG. XXXIX.

§ XII. I wish, however, at present to fix the reader's attention on the form of the bracket itself; a most important feature in modern as well as ancient architecture. The first idea of a bracket is that of a long stone or piece of timber projecting from the wall, as *a*, Fig. XXXIX., of which the strength depends on the toughness of the stone or wood, and the stability on the weight of the wall above it (unless it be the end of a main beam). But let it be supposed that the structure at *a*, being of the required projection, is found too weak: then we may strengthen it in one of three ways; (1) by putting a second or third stone beneath it, as at *b*; (2) by giving it a spur, as at *c*; (3) by giving it a shaft and another bracket below, *d*; the great

use of this arrangement being that the lowermost bracket has the help of the weight of the shaft length of wall above its insertion, which is, of course, greater than the weight of the small shaft: and then the lower bracket may be farther helped by the structure at *b* or *c*.

§ XIII. Of these structures, *a* and *c* are evidently adapted especially for wooden buildings; *b* and *d* for stone ones; the last, of course, susceptible of the richest decoration, and superbly employed in the cornice of the cathedral of Monza: but all are beautiful in their way, and are the means of, I think, nearly half the picturesqueness and power of mediæval building; the forms *b* and *c* being, of course, the most frequent; *a*, when it occurs, being usually rounded off, as at *a*, Fig. XL.; *b*, also, as in Fig. XXXVIII., or else itself composed of a single stone cut into the form of the group *b* here, Fig. XL., or plain, as at *c*, which is also the proper form of the brick bracket, when stone is not to be had. The reader will at once perceive that the form *d* is a barbarism (unless when the scale is small and the weight to be carried exceedingly light): it is of course, therefore, a favorite form with the Renaissance architects; and its introduction is one of the first corruptions of the Venetian architecture.

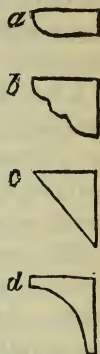

FIG. XL.

§ XIV. There is one point necessary to be noticed, though bearing on decoration more than construction, before we leave the subject of the bracket. The whole power of the construction depends upon the stones being well *let into* the wall; and the first function of the decoration should be to give the idea of this insertion, if possible; at all events, not to contradict this idea. If the reader will glance at any of the brackets used in the ordinary architecture of London, he will find them of some such character as Fig. XLI.; not a bad form in itself, but exquisitely absurd in its curling lines, which give the idea of some writhing suspended tendril, instead of a stiff support, and by their careful avoidance of the wall make the bracket look pinned on, and in constant danger of sliding down. This is, also, a Classical and Renaissance decoration.



FIG. XLI. which give the idea of some writhing suspended tendril, instead of a stiff support, and by their careful avoidance of the wall make the bracket look pinned on, and in constant danger of sliding down. This is, also, a Classical and Renaissance decoration.

§ XV. 2. The Parapet. Its forms are fixed in military architecture by the necessities of the art of war at the time of building, and are always beautiful wherever they have been

really thus fixed ; delightful in the variety of their setting, and in the quaint darkness of their shot-holes, and fantastic changes of elevation and outline. Nothing is more remarkable than the swiftly discerned difference between the masculine irregularity of such true battlements, and the formal pitifulness of those which are set on modern buildings to give them a military air,—as on the jail at Edinburgh.

§ XVI. Respecting the Parapet for mere safeguard upon buildings not military, there are just two fixed laws. It should be pierced, otherwise it is not recognised from below for a parapet at all, and it should not be in the form of a battlement, especially in church architecture.

The most comfortable heading of a true parapet is a plain level on which the arm can be rested, and along which it can glide. Any jags or elevations are disagreeable ; the latter, as interrupting the view and disturbing the eye, if they are higher than the arm, the former, as opening some aspect of danger if they are much lower ; and the inconvenience, therefore, of the battlemented form, as well as the worse than absurdity, the bad feeling, of the appliance of a military feature to a church, ought long ago to have determined its rejection. Still (for the question of its picturesque value is here so closely connected with that of its practical use, that it is vain to endeavor to discuss it separately) there is a certain agreeableness in the way in which the jagged outline dovetails the shadow of the slated or leaded roof into the top of the wall, which may make the use of the battlement excusable where there is a difficulty in managing some unvaried line, and where the expense of a pierced parapet cannot be encountered : but remember always, that the value of the battlement consists in its letting shadow into the light of the wall, or *vice versâ*, when it comes against light sky, letting the light of the sky into the shade of the wall ; but that the actual outline of the parapet itself, if the eye be arrested upon this, instead of upon the alternation of shadow, is as *ugly* a succession of line as can by any possibility be invented. Therefore, the battlemented parapet may only be used where this alternation of shade is certain to be shown, under nearly all

conditions of effect ; and where the lines to be dealt with are on a scale which may admit battlements of bold and manly size. The idea that a battlement is an ornament anywhere, and that a miserable and diminutive imitation of castellated outline will always serve to fill up blanks and Gothicise unmanageable spaces, is one of the great idiocies of the present day. A battlement is in its origin a piece of wall large enough to cover a man's body, and however it may be decorated, or pierced, or finessed away into traceries, as long as so much of its outline is retained as to suggest its origin, so long its size must remain undiminished. To crown a turret six feet high with chopped battlements three inches wide, is children's Gothic : it is one of the paltry falsehoods for which there is no excuse, and part of the system of using models of architecture to decorate architecture, which we shall hereafter note as one of the chief and most destructive follies of the Renaissance ;* and in the present day the practice may be classed as one which distinguishes the architects of whom there is no hope, who have neither eye nor head for their work, and who must pass their lives in vain struggles against the refractory lines of their own buildings.

§ XVII. As the only excuse for the battlemented parapet is its alternation of shadow, so the only fault of the natural or level parapet is its monotony of line. This is, however, in practice, almost always broken by the pinnacles of the buttresses, and if not, may be varied by the tracery of its penetrations. The forms of these evidently admit every kind of change ; for a stone parapet, however pierced, is sure to be strong enough for its purpose of protection, and, as regards

* Not of Renaissance alone : the practice of modelling buildings on a minute scale for niches and tabernacle-work has always been more or less admitted, and I suppose *authority* for diminutive battlements might be gathered from the Gothic of almost every period, as well as for many other faults and mistakes : no Gothic school having ever been thoroughly systematised or perfected, even in its best times. But that a mistaken decoration sometimes occurs among a crowd of noble ones, is no more an excuse for the habitual—far less, the exclusive—use of such a decoration, than the accidental or seeming misconstructions of a Greek chorus are an excuse for a school boy's ungrammatical exercise.

the strength of the building in general, the lighter it is the better. More fantastic forms may, therefore, be admitted in a parapet than in any other architectural feature, and for most services, the Flamboyant parapets seem to me preferable to all others; especially when the leaden roofs set off by points of darkness the lace-like intricacy of penetration. These, however, as well as the forms usually given to Renaissance balustrades (of which, by the bye, the best piece of criticism I know is the sketch in "David Copperfield" of the personal appearance of the man who stole Jip), and the other and finer forms invented by Paul Veronese in his architectural backgrounds, together with the pure columnar balustrade of Venice, must be considered as altogether decorative features.

§ XVIII. So also are, of course, the jagged or crown-like finishings of walls employed where no real parapet of protection is desired; originating in the defences of outworks and single walls: these are used much in the east on walls surrounding unroofed courts. The richest examples of such decoration are Arabian; and from Cairo they seem to have been brought to Venice. It is probable that few of my readers, however familiar the general form of the Ducal Palace may have been rendered to them by innumerable drawings, have any distinct idea of its roof, owing to the staying of the eye on its superb parapet, of which we shall give account hereafter. In most of the Venetian cases the parapets which surround roofing are very sufficient for protection, except that the stones of which they are composed appear loose and infirm: but their purpose is entirely decorative; every wall, whether detached or roofed, being indiscriminately fringed with Arabic forms of parapet, more or less Gothified, according to the lateness of their date.

I think there is no other point of importance requiring illustration respecting the roof itself, or its cornice: but this Venetian form of ornamental parapet connects itself curiously, at the angles of nearly all the buildings on which it occurs, with the pinnacled system of the north, founded on the structure of the buttress. This, it will be remembered, is to be the subject of the fifth division of our inquiry.

CHAPTER XV.

THE BUTTRESS.

§ I. WE have hitherto supposed ourselves concerned with the support of vertical pressure only ; and the arch and roof have been considered as forms of abstract strength, without reference to the means by which their lateral pressure was to be resisted. Few readers will need now to be reminded, that every arch or gable not tied at its base by beams or bars, exercises a lateral pressure upon the walls which sustain it,—pressure which may, indeed, be met and sustained by increasing the thickness of the wall or vertical piers, and which is in reality thus met in most Italian buildings, but may, with less expenditure of material, and with (perhaps) more graceful effect, be met by some particular application of the provisions against lateral pressure called Buttresses. These, therefore, we are next to examine.

§ II. Buttresses are of many kinds, according to the character and direction of the lateral forces they are intended to resist. But their first broad division is into buttresses which meet and break the force before it arrives at the wall, and buttresses which stand on the lee side of the wall, and prop it against the force.

The lateral forces which walls have to sustain are of three distinct kinds: dead weight, as of masonry or still water ; moving weight, as of wind or running water ; and sudden concussion, as of earthquakes, explosions, &c.

Clearly, dead weight can only be resisted by the buttress acting as a prop ; for a buttress on the side of, or towards the weight, would only add to its effect. This, then, forms the first great class of buttressed architecture ; lateral thrusts, of roofing or arches, being met by props of masonry outside—the thrusts from within, the prop without ; or the crushing force of water on a ship's side met by its cross timbers—the thrust here from without the wall, the prop within.

Moving weight may, of course, be resisted by the prop on

the lee side of the wall, but is often more effectually met, on the side which is attacked, by buttresses of peculiar forms, cunning buttresses, which do not attempt to sustain the weight, but *parry* it, and throw it off in directions clear of the wall.

Thirdly : concussions and vibratory motion, though in reality only supported by the prop buttress, must be provided for by buttresses on both sides of the wall, as their direction cannot be foreseen, and is continually changing.

We shall briefly glance at these three systems of buttressing ; but the two latter being of small importance to our present purpose, may as well be dismissed first.

§ III. 1. Buttresses for guard against moving weight and set towards the weight they resist.

The most familiar instance of this kind of buttress we have in the sharp piers of a bridge, in the centre of a powerful stream, which divide the current on their edges, and throw it to each side under the arches. A ship's bow is a buttress of the same kind, and so also the ridge of a breastplate, both adding to the strength of it in resisting a cross blow, and giving a better chance of a bullet glancing aside. In Switzerland, projecting buttresses of this kind are often built round churches, heading up hill, to divide and throw off the avalanches. The various forms given to piers and harbor quays, and to the bases of lighthouses, in order to meet the force of the waves, are all conditions of this kind of buttress. But in works of ornamental architecture such buttresses are of rare occurrence ; and I merely name them in order to mark their place in our architectural system, since in the investigation of our present subject we shall not meet with a single example of them, unless sometimes the angle of the foundation of a palace set against the sweep of the tide, or the wooden piers of some canal bridge quivering in its current.

§ IV. 2. Buttresses for guard against vibratory motion.

The whole formation of this kind of buttress resolves itself into mere expansion of the base of the wall, so as to make it stand steadier, as a man stands with his feet apart when he is likely to lose his balance. This approach to a pyramidal form

is also of great use as a guard against the action of artillery ; that if a stone or tier of stones be battered out of the lower portions of the wall, the whole upper part may not topple over or crumble down at once. Various forms of this buttress, sometimes applied to particular points of the wall, sometimes forming a great sloping rampart along its base, are frequent in buildings of countries exposed to earthquake. They give a peculiarly heavy outline to much of the architecture of the kingdom of Naples, and they are of the form in which strength and solidity are first naturally sought, in the slope of the Egyptian wall. The base of Guy's Tower at Warwick is a singularly bold example of their military use ; and so, in general, bastion and rampart profiles, where, however, the object of stability against a shock is complicated with that of sustaining weight of earth in the rampart behind.

§ v. 3. Prop buttresses against dead weight.

This is the group with which we have principally to do ; and a buttress of this kind acts in two ways, partly by its weight and partly by its strength. It acts by its weight when its mass is so great that the weight it sustains cannot stir it, but is lost upon it, buried in it, and annihilated : neither the shape of such a buttress nor the cohesion of its materials are of much consequence ; a heap of stones or sandbags, laid up against the wall, will answer as well as a built and cemented mass.

But a buttress acting by its strength is not of mass sufficient to resist the weight by mere inertia ; but it conveys the weight through its body to something else which is so capable ; as, for instance, a man leaning against a door with his hands, and propping himself against the ground, conveys the force which would open or close the door against him through his body to the ground. A buttress acting in this way must be of perfectly coherent materials, and so strong that though the weight to be borne could easily move it, it cannot break it : this kind of buttress may be called a conducting buttress. Practically, however, the two modes of action are always in some sort united. Again, the weight to be borne may either act generally on the whole wall surface, or with excessive en-

ergy on particular points : when it acts on the whole wall surface, the whole wall is generally supported ; and the arrangement becomes a continuous rampart, as a dyke, or bank of reservoir.

§ VI. It is, however, very seldom that lateral force in architecture is equally distributed. In most cases the weight of the roof, or the force of any lateral thrust, are more or less confined to certain points and directions. In an early state of architectural science this definiteness of direction is not yet clear, and it is met by uncertain application of mass or strength in the buttress, sometimes by mere thickening of the wall into square piers, which are partly piers, partly buttresses, as in Norman keeps and towers. But as science advances, the weight to be borne is designedly and decisively thrown upon certain points ; the direction and degree of the forces which are then received are exactly calculated, and met by conducting buttresses of the smallest possible dimensions ; themselves, in their turn, supported by vertical buttresses acting by weight, and these perhaps, in their turn, by another set of conducting buttresses : so that, in the best examples of such arrangements, the weight to be borne may be considered as the shock of an electric fluid, which, by a hundred different rods and channels, is divided and carried away into the ground.

§ VII. In order to give greater weight to the vertical buttress piers which sustain the conducting buttresses, they are loaded with pinnacles, which, however, are, I believe, in all the buildings in which they become very prominent, merely decorative : they are of some use, indeed, by their weight ; but if this were all for which they were put there, a few cubic feet of lead would much more securely answer the purpose, without any danger from exposure to wind. If the reader likes to ask any Gothic architect with whom he may happen to be acquainted, to substitute a lump of lead for his pinnacles, he will see by the expression of his face how far he considers the pinnacles decorative members. In the work which seems to me the great type of simple and masculine buttress structure, the apse of Beauvais, the pinnacles are altogether insignificant, and are evidently added just as exclusively to enter-

tain the eye and lighten the aspect of the buttress, as the slight shafts which are set on its angles ; while in other very noble Gothic buildings the pinnacles are introduced as niches for statues, without any reference to construction at all : and sometimes even, as in the tomb of Can Signoria at Verona, on small piers detached from the main building.

§ VIII. I believe, therefore, that the development of the pinnacle is merely a part of the general erectness and picturesqueness of northern work above alluded to : and that, if there had been no other place for the pinnacles, the Gothic builders would have put them on the tops of their arches (they often *did* on the tops of gables and pediments), rather than not have had them ; but the natural position of the pinnacle is, of course, where it adds to, rather than diminishes, the stability of the building ; that is to say, on its main wall piers and the vertical piers at the buttresses. And thus the edifice is surrounded at last by a complete company of detached piers and pinnacles, each sustaining an inclined prop against the central wall, and looking something like a band of giants holding it up with the butts of their lances. This arrangement would imply the loss of an enormous space of ground, but the intervals of the buttresses are usually walled in below, and form minor chapels.

§ IX. The science of this arrangement has made it the subject of much enthusiastic declamation among the Gothic architects, almost as unreasonable, in some respects, as the declamation of the Renaissance architects respecting Greek structure. The fact is, that the whole northern buttress system is based on the grand requirement of tall windows and vast masses of light at the end of the apse. In order to gain this quantity of light, the piers between the windows are diminished in thickness until they are far too weak to bear the roof, and then sustained by external buttresses. In the Italian method the light is rather dreaded than desired, and the wall is made wide enough between the windows to bear the roof, and so left. In fact, the simplest expression of the difference in the systems is, that a northern apse is a southern one with its inter-fenestrial piers set edgeways. Thus, *a*, Fig. XLII, is

the general idea of the southern apse ; take it to pieces, and set all its piers edgeways, as at *b*, and you have the northern one. You gain much light for the interior, but you cut the exterior to pieces, and instead of a bold rounded or polygonal surface, ready for any kind of decoration, you have a series of dark and damp cells, which no device that I have yet seen has succeeded in decorating in a perfectly satisfactory manner. If the system be farther carried, and a second or third order of buttresses be added, the real fact is that we have a building standing on two or three rows of concentric piers, with the *roof off* the whole of it except the central circle, and only ribs left, to carry the weight of the bit of remaining roof in the middle ; and after the eye has been accustomed to the

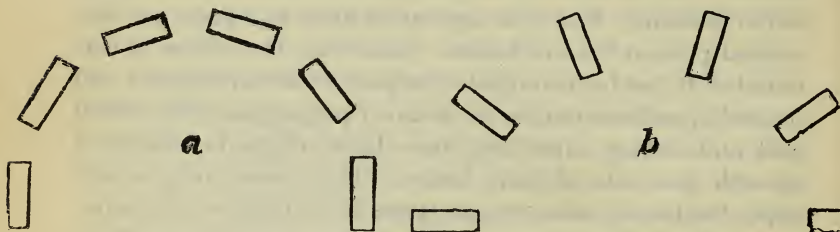

FIG. XLII.

bold and simple rounding of the Italian apse, the skeleton character of the disposition is painfully felt. After spending some months in Venice, I thought Bourges Cathedral looked exactly like a half-built ship on its shores. It is useless, however, to dispute respecting the merits of the two systems ; both are noble in their place ; the Northern decidedly the most scientific, or at least involving the greatest display of science, the Italian the calmest and purest, this having in it the sublimity of a calm heaven or a windless noon, the other that of a mountain flank tormented by the north wind, and withering into grisly furrows of alternate chasm and crag.

§ x. If I have succeeded in making the reader understand the veritable action of the buttress, he will have no difficulty in determining its fittest form. He has to deal with two distinct kinds ; one, a narrow vertical pier, acting principally by

its weight, and crowned by a pinnacle ; the other, commonly called a Flying buttress, a cross bar set from such a pier (when detached from the building) against the main wall. This latter, then, is to be considered as a mere prop or shore, and its use by the Gothic architects might be illustrated by the supposition that we were to build all our houses with walls too thin to stand without wooden props outside, and then to substitute stone props for wooden ones. I have some doubts of the real dignity of such a proceeding, but at all events the merit of the form of the flying buttress depends on its faithfully and visibly performing this somewhat humble office ; it is, therefore, in its purity, a mere sloping bar of stone, with an arch beneath it to carry its weight, that is to say, to prevent the action of gravity from in any wise deflecting it, or causing it to break downwards under the lateral thrust ; it is thus formed quite simple in Notre Dame of Paris, and in the Cathedral of Beauvais, while at Cologne the sloping bars are pierced with quatrefoils, and at Amiens with traceried arches. Both seem to me effeminate and false in principle ; not, of course, that there is any occasion to make the flying buttress heavy, if a light one will answer the purpose ; but it seems as if some security were sacrificed to ornament. At Amiens the arrangement is now seen to great disadvantage, for the early traceries have been replaced by base flamboyant ones, utterly weak and despicable. Of the degradations of the original form which took place in after times, I have spoken at p. 35 of the "Seven Lamps."

§ XI. The form of the common buttress must be familiar to the eye of every reader, sloping if low, and thrown into successive steps if they are to be carried to any considerable height. There is much dignity in them when they are of essential service ; but even in their best examples, their awkward angles are among the least manageable features of the Northern Gothic, and the whole organisation of its system was destroyed by their unnecessary and lavish application on a diminished scale ; until the buttress became actually confused with the shaft, and we find strangely crystallised masses of diminutive buttress applied, for merely vertical support, in the

northern tabernacle work ; while in some recent copies of it the principle has been so far distorted that the tiny buttressings look as if they carried the superstructure on the points of their pinnacles, as in the Cranmer memorial at Oxford. Indeed, in most modern Gothic, the architects evidently consider buttresses as convenient breaks of blank surface, and general apologies for deadness of wall. They stand in the place of ideas, and I think are supposed also to have something of the odor of sanctity about them ; otherwise, one hardly sees why a warehouse seventy feet high should have nothing of the kind, and a chapel, which one can just get into with one's hat off, should have a bunch of them at every corner ; and worse than this, they are even thought ornamental when they can be of no possible use ; and these stupid penthouse outlines are forced upon the eye in every species of decoration : in St. Margaret's Chapel, West Street, there are actually a couple of buttresses at the end of every pew.

§ XII. It is almost impossible, in consequence of these unwise repetitions of it, to contemplate the buttress without some degree of prejudice ; and I look upon it as one of the most justifiable causes of the unfortunate aversion with which many of our best architects regard the whole Gothic school. It may, however, always be regarded with respect when its form is simple and its service clear ; but no treason to Gothic can be greater than the use of it in indolence or vanity, to enhance the intricacies of structure, or occupy the vacuities of design.

CHAPTER XVI.

FORM OF APERTURE.

§ I. WE have now, in order, examined the means of raising walls and sustaining roofs, and we have finally to consider the structure of the necessary apertures in the wall veil, the door and window ; respecting which there are three main points to be considered.

1. The form of the aperture, *i.e.*, its outline, its size, and the forms of its sides.
2. The filling of the aperture, *i.e.*, valves and glass, and their holdings.
3. The protection of the aperture, and its appliances, *i.e.*, canopies, porches, and balconies. We shall examine these in succession.

§ II. 1. The form of the aperture: and first of doors. We will, for the present, leave out of the question doors and gates in unroofed walls, the forms of these being very arbitrary, and confine ourselves to the consideration of doors of entrance into roofed buildings. Such doors will, for the most part, be at, or near, the base of the building; except when raised for purposes of defence, as in the old Scotch border towers, and our own Martello towers, or, as in Switzerland, to permit access in deep snow, or when stairs are carried up outside the house for convenience or magnificence. But in most cases, whether high or low, a door may be assumed to be considerably lower than the apartments or buildings into which it gives admission, and therefore to have some height of wall above it, whose weight must be carried by the heading of the door. It is clear, therefore, that the best heading must be an arch, because the strongest, and that a square-headed door must be wrong, unless under Mont-Cenisian masonry; or else, unless the top of the door be the roof of the building, as in low cottages. And a square-headed door is just so much more wrong and ugly than a connexion of main shafts by lintels, as the weight of wall above the door is likely to be greater than that above the main shafts. Thus, while I admit the Greek general forms of temple to be admirable in their kind, I think the Greek door always offensive and unmanageable.

§ III. We have it also determined by necessity, that the apertures shall be at least above a man's height, with perpendicular sides (for sloping sides are evidently unnecessary, and even inconvenient, therefore absurd) and level threshold; and this aperture we at present suppose simply cut through the wall without any bevelling of the jambs. Such a door, wide

enough for two persons to pass each other easily, and with such fillings or valves as we may hereafter find expedient, may be fit enough for any building into which entrance is required neither often, nor by many persons at a time. But when entrance and egress are constant, or required by crowds, certain further modifications must take place.

§ iv. When entrance and egress are constant, it may be supposed that the valves will be absent or unfastened,—that

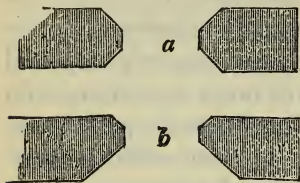

Fig. XLIII.

people will be passing more quickly than when the entrance and egress are unfrequent, and that the square angles of the wall will be inconvenient to such quick passers through. It is evident, therefore, that what would be done in time, for themselves, by the passing

multitude, should be done for them at once by the architect ; and that these angles, which would be worn away by friction, should at once be bevelled off, or, as it is called, splayed, and the most contracted part of the aperture made as short as possible, so that the plan of the entrance should become as at *a*, Fig. XLIII.

§ v. Farther. As persons on the outside may often approach the door or depart from it, *beside* the building, so as to turn aside as they enter or leave the door, and therefore touch its jamb, but, on the inside, will in almost every case approach the door, or depart from it in the direct line of the entrance (people generally walking *forward* when they enter a hall, court, or chamber of any kind, and being forced to do so when they enter a passage), it is evident that the bevelling may be very slight on the inside, but should be large on the outside, so that the plan of the aperture should become as at *b*, Fig. XLIII. Farther, as the bevelled wall cannot conveniently carry an unbevelled arch, the door arch must be bevelled also, and the aperture, seen from the outside, will have somewhat the aspect of a small cavern diminishing towards the interior.

§ vi. If, however, beside frequent entrance, entrance is re

quired for multitudes at the same time, the size of the aperture either must be increased, or other apertures must be introduced. It may, in some buildings, be optional with the architect whether he shall give many small doors, or few large ones; and in some, as theatres, amphitheatres, and other places where the crowd are apt to be impatient, many doors are by far the best arrangement of the two. Often, however, the purposes of the building, as when it is to be entered by processions, or where the crowd most usually enter in one direction, require the large single entrance; and (for here again the æsthetic and structural laws cannot be separated) the expression and harmony of the building require, in nearly every case, an entrance of largeness proportioned to the multitude which is to meet within. Nothing is more unseemly than that a great multitude should find its way out and in, as ants and wasps do, through holes; and nothing more undignified than the paltry doors of many of our English cathedrals, which look as if they were made, not for the open egress, but for the surreptitious drainage of a stagnant congregation. Besides, the expression of the church door should lead us, as far as possible, to desire at least the western entrance to be single, partly because no man of right feeling would willingly lose the idea of unity and fellowship in going up to worship, which is suggested by the vast single entrance; partly because it is at the entrance that the most serious words of the building are always addressed, by its sculptures or inscriptions, to the worshipper; and it is well, that these words should be spoken to all at once, as by one great voice, not broken up into weak repetitions over minor doors.

In practice the matter has been, I suppose, regulated almost altogether by convenience, the western doors being single in small churches, while in the larger the entrances become three or five, the central door remaining always principal, in consequence of the fine sense of composition which the mediæval builders never lost. These arrangements have formed the noblest buildings in the world. Yet it is worth observing*

* And worth questioning, also, whether the triple porch has not been associated with Romanist views of mediatorship; the Redeemer being

how perfect in its simplicity the single entrance may become, when it is treated as in the Duomo and St. Zeno of Verona, and other such early Lombard churches, having noble porches, and rich sculptures grouped around the entrance.

§ VII. However, whether the entrances be single, triple, or manifold, it is a constant law that one shall be principal, and all shall be of size in some degree proportioned to that of the building. And this size is, of course, chiefly to be expressed in width, that being the only useful dimension in a door (except for pageantry, chairing of bishops and waving of banners, and other such vanities, not, I hope, after this century, much to be regarded in the building of Christian temples); but though the width is the only necessary dimension, it is well to increase the height also in some proportion to it, in order that there may be less weight of wall above, resting on the increased span of the arch. This is, however, so much the necessary result of the broad curve of the arch itself, that there is no structural necessity of elevating the jamb; and I believe that beautiful entrances might be made of every span of arch, retaining the jamb at a little more than a man's height, until the sweep of the curves became so vast that the small vertical line became a part of them, and one entered into the temple as under a great rainbow.

§ VIII. On the other hand, the jamb *may* be elevated indefinitely, so that the increasing entrance retains *at least* the proportion of width it had originally; say 4 ft. by 7 ft. 5 in. But a less proportion of width than this has always a meagre, inhospitable, and ungainly look except in military architecture, where the narrowness of the entrance is necessary, and its

represented as presiding over the central door only, and the lateral entrances being under the protection of saints, while the Madonna almost always has one or both of the transepts. But it would be wrong to press this, for, in nine cases out of ten, the architect has been merely influenced in his placing of the statues by an artist's desire of variety in their forms and dress; and very naturally prefers putting a canonisation over one door, a martyrdom over another, and an assumption over a third, to repeating a crucifixion or a judgment above all. The architect's doctrine is only, therefore, to be noted with indisputable reprobation when the Madonna gets possession of the main door.

height adds to its grandeur, as between the entrance towers of our British castles. This law however, observe, applies only to true doors, not to the arches of porches, which may be of any proportion, as of any number, being in fact intercolumniations, not doors; as in the noble example of the west front of Peterborough, which, in spite of the destructive absurdity of its central arch being the narrowest, would still, if the paltry porter's lodge, or gatehouse, or turnpike, or whatever it is, were knocked out of the middle of it, be the noblest west front in England.

§ ix. Further, and finally. In proportion to the height and size of the building, and therefore to the size of its doors, will be the thickness of its walls, especially at the foundation, that is to say, beside the doors; and also in proportion to the numbers of a crowd will be the unruliness and pressure of it. Hence, partly in necessity and partly in prudence, the splaying or chamfering of the jamb of the larger door will be deepened, and, if possible, made at a larger angle for the large door than for the small one; so that the large door will always be encompassed by a visible breadth of jamb proportioned to its own magnitude. The decorative value of this feature we shall see hereafter.

§ x. The second kind of apertures we have to examine are those of windows.

Window apertures are mainly of two kinds; those for outlook, and those for inlet of light, many being for both purposes, and either purpose, or both, combined in military architecture with those of offence and defence. But all window apertures, as compared with door apertures, have almost infinite licence of form and size: they may be of any shape, from the slit or cross slit to the circle;* of any size, from the loophole of the castle to the pillars of light of the cathedral apse. Yet, according to their place and purpose, one or two

* The arch heading is indeed the best where there is much incumbent weight, but a window frequently has very little weight above it, especially when placed high, and the arched form loses light in a low room: therefore the square-headed window is admissible where the square-headed door is not.

laws of fitness hold respecting them, which let us examine in the two classes of windows successively, but without reference to military architecture, which here, as before, we may dismiss as a subject of separate science, only noticing that windows, like all other features, are always delightful, if not beautiful, when their position and shape have indeed been thus necessarily determined, and that many of their most picturesque forms have resulted from the requirements of war. We should also find in military architecture the typical forms of the two classes of outlet and inlet windows in their utmost development; the greatest sweep of sight and range of shot on the one hand, and the fullest entry of light and air on the other, being constantly required at the smallest possible apertures. Our business, however, is to reason out the laws for ourselves, not to take the examples as we find them.

§ XI. 1. Outlook apertures. For these no general outline is determinable by the necessities or inconveniences of outlooking, except only that the bottom or sill of the windows, at whatever height, should be horizontal, for the convenience of leaning on it, or standing on it if the window be to the ground. The form of the upper part of the window is quite immaterial, for all windows allow a greater range of sight when they are *approached* than that of the eye itself: it is the approachability of the window, that is to say, the annihilation of the thickness of the wall, which is the real point to be attended to. If, therefore, the aperture be inaccessible, or so small that the thickness of the wall cannot be entered, the wall is to be bevelled * on the outside, so as to increase the range of sight as far as possible; if the aperture can be entered, then bevelled from the point to which entrance is possible. The beveling will, if possible, be in every direction, that is to say, upwards at the top, outwards at the sides, and downwards at the bottom, but essentially *downwards*; the earth and the doings upon it being the chief object in outlook windows, except of observatories; and where the object is a distinct and special view downwards, it will be of advantage to shelter the eye as far

* I do not like the sound of the word "splayed;" I always shall use "bevelled" instead.

as possible from the rays of light coming from above, and the head of the window may be left horizontal, or even the whole aperture sloped outwards, as the slit in a letter-box is inwards.

The best windows for outlook are, of course, oriels and bow windows, but these are not to be considered under the head of apertures merely; they are either balconies roofed and glazed, and to be considered under the head of external appliances, or they are each a story of an external semi-tower having true aperture windows on each side of it.

§ XII. 2. Inlet windows. These windows may, of course, be of any shape and size whatever, according to the other necessities of the building, and the quantity and direction of light desired, their purpose being now to throw it in streams on particular lines or spots; now to diffuse it everywhere; sometimes to introduce it in broad masses, tempered in strength, as in the cathedral colored window; sometimes in starry showers of scattered brilliancy, like the apertures in the roof of an Arabian bath; perhaps the most beautiful of all forms being the rose, which has in it the unity of both characters and sympathy with that of the source of light itself. It is noticeable, however, that while both the circle and pointed oval are beautiful window forms, it would be very painful to cut either of them in half and connect them by vertical lines, as in Fig. XLIV. The reason is, I believe, that so treated, the upper arch is not considered as connected with the lower, and forming an entire figure, but as the ordinary arch roof of the aperture, and the lower arch as an arch *floor*, equally unnecessary and unnatural. Also, the elliptical oval is generally an unsatisfactory form, because it gives the idea of useless trouble in building it, though it occurs quaintly and pleasantly in the former windows of France: I believe it is also objectionable because it has an indeterminate, slippery look, like that of a bubble rising through a fluid. It, and all elongated forms, are still more objectionable placed horizontally, because this is the weakest position they can structurally have; that is to say, less light is admitted, with greater loss of strength to the building, than by any other

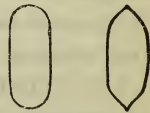

FIG. XLIV.

form. If admissible anywhere, it is for the sake of variety at the top of the building, as the flat parallelogram sometimes not ungracefully in Italian Renaissance.

§ XIII. The question of bevelling becomes a little more complicated in the inlet than the outlook window, because the mass or quantity of light admitted is often of more consequence than its direction, and often *vice versâ*; and the outlook window is supposed to be approachable, which is far from being always the case with windows for light, so that the bevelling which in the outlook window is chiefly to open range of sight, is in the inlet a means not only of admitting the light in greater quantity, but of directing it to the spot on which it is to fall. But, in general, the bevelling of the one window will reverse that of the other; for, first, no natural light will strike on the inlet window from beneath, unless reflected light, which is (I believe) injurious to the health and the sight; and thus, while in the outlook window the outside bevel downwards is essential, in the inlet it would be useless: and the sill is to be flat, if the window be on a level with the spot it is to light; and sloped downwards within, if above it. Again, as the brightest rays of light are the steepest, the outside bevel upwards is as essential in the roof of the inlet as it was of small importance in that of the outlook window.

§ XIV. On the horizontal section the aperture will expand internally, a somewhat larger number of rays being thus reflected from the jambs; and the aperture being thus the smallest possible outside, this is the favorite military form of inlet window, always found in magnificent development in the thick walls of mediæval castles and convents. Its effect is tranquil, but cheerless and dungeon-like in its fullest development, owing to the limitation of the range of sight in the outlook, which, if the window be unapproachable, reduces it to a mere point of light. A modified condition of it, with some combination of the outlook form, is probably the best for domestic buildings in general (which, however, in modern architecture, are unhappily so thin walled, that the outline of the jambs becomes a matter almost of indifference), it being gen-

erally noticeable that the depth of recess which I have observed to be essential to nobility of external effect has also a certain dignity of expression, as appearing to be intended rather to admit light to persons quietly occupied in their homes, than to stimulate or favor the curiosity of idleness.

CHAPTER XVII.

FILLING OF APERTURE.

§ I. Thus far we have been concerned with the outline only of the aperture: we were next, it will be remembered, to consider the necessary modes of filling it with valves in the case of the door, or with glass or tracery in that of the window.

1. Fillings of doors. We concluded, in the previous Chapter, that doors in buildings of any importance or size should have headings in the form of an arch. This is, however, the most inconvenient form we could choose, as respects the fitting of the valves of the doorway; for the arch-shaped head of the valves not only requires considerable nicety in fitting to the arch, but adds largely to the weight of the door,—a double disadvantage, straining the hinges and making it cumbersome in opening. And this inconvenience is so much perceived by the eye, that a door valve with a pointed head is always a disagreeable object. It becomes, therefore, a matter of true necessity so to arrange the doorway as to admit of its being fitted with rectangular valves.

§ II. Now, in determining the form of the aperture, we supposed the jamb of the door to be of the utmost height required for entrance. The extra height of the arch is unnecessary as an opening, the arch being required for its strength only, not for its elevation. There is, therefore, no reason why it should not be barred across by a horizontal lintel, into which the valves may be fitted, and the triangular or semicircular arched space above the lintel may then be permanently closed, as we choose, either with bars, or glass, or stone.

This is the form of all good doors, without exception, over the whole world and in all ages, and no other can ever be invented.

§ III. In the simplest doors the cross lintel is of wood only, and glass or bars occupy the space above, a very frequent form in Venice. In more elaborate doors the cross lintel is of stone, and the filling sometimes of brick, sometimes of stone, very often a grand single stone being used to close the entire space: the space thus filled is called the Tympanum. In large doors the cross lintel is too long to bear the great incumbent weight of this stone filling without support; it is, therefore, carried by a pier in the centre; and two valves are used, fitted to the rectangular spaces on each side of the pier. In the most elaborate examples of this condition, each of these secondary doorways has an arch heading, a cross lintel, and a triangular filling or tympanum of its own, all subordinated to the main arch above.

§ IV. 2. Fillings of windows.

When windows are large, and to be filled with glass, the sheet of glass, however constructed, whether of large panes or small fragments, requires the support of bars of some kind, either of wood, metal, or stone. Wood is inapplicable on a large scale, owing to its destructibility; very fit for door-valves, which can be easily refitted, and in which weight would be an inconvenience, but very unfit for window-bars, which, if they decayed, might let the whole window be blown in before their decay was observed, and in which weight would be an advantage, as offering more resistance to the wind.

Iron is, however, fit for window-bars, and there seems no constructive reason why we should not have iron trceries, as well as iron pillars, iron churches, and iron steeples. But I have, in the "Seven Lamps," given reasons for not considering such structures as architecture at all.

The window-bars must, therefore, be of stone, and of stone only.

§ V. The purpose of the window being always to let in as much light, and command as much view, as possible, these

bars of stone are to be made as slender and as few as they can be, consistently with their due strength.

Let it be required to support the breadth of glass, *a, b*, Fig. XLV. The tendency of the glass sustaining any force, as of wind from without, is to bend into an arch inwards, in the dotted line, and break in the centre. It is to be supported, therefore, by the bar put in its centre, *c*.

But this central bar, *c*, may not be enough, and the spaces *a c, c b*, may still need support. The next step will be to put two bars instead of one, and divide the window into three spaces as at *d*.

But this may still not be enough, and the window may need three bars. Now the greatest stress is always on the centre of the window. If the three bars are equal in strength, as at *e*, the central bar is either too slight for its work, or the lateral bars too thick for theirs. Therefore, we must slightly increase the thickness of the central bar, and diminish that of the lateral ones, so as to obtain the arrangement at *f h*. If the window enlarge farther, each of the spaces *f g, g h*, is treated as the original space *a b*, and we have the groups of bars *k* and *l*.

So that, whatever the shape of the window, whatever the direction and number of the bars, there are to be central or main bars; second bars subordinated to them; third bars subordinated to the second, and so on to the number required. This is called the subordination of tracery, a system delightful to the eye and mind, owing to its anatomical framing and unity, and to its expression of the laws of good government in all fragile and unstable things. All tracery, therefore, which is not subordinated, is barbarous, in so far as this part of its structure is concerned.

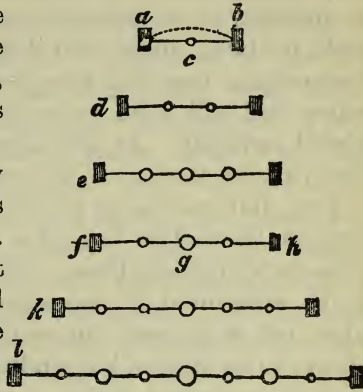

FIG. XLV.

§ vi. The next question will be the direction of the bars. The reader will understand at once, without any laborious proof, that a given area of glass, supported by its edges, is stronger in its resistance to violence when it is arranged in a long strip or band than in a square; and that, therefore, glass is generally to be arranged, especially in windows on a large scale, in oblong areas: and if the bars so dividing it be placed horizontally, they will have less power of supporting themselves, and will need to be thicker in consequence, than if placed vertically. As far, therefore, as the form of the window permits, they are to be vertical.

§ vii. But even when so placed, they cannot be trusted to support themselves beyond a certain height, but will need cross bars to steady them. Cross bars of stone are, therefore, to be introduced at necessary intervals, not to divide the glass, but to support the upright stone bars. The glass is always to be divided longitudinally as far as possible, and the upright bars which divide it supported at proper intervals. However high the window, it is almost impossible that it should require more than two cross bars.

§ viii. It may sometimes happen that when tall windows are placed very close to each other for the sake of more light, the masonry between them may stand in need, or at least be the better of, some additional support. The cross bars of the windows may then be thickened, in order to bond the intermediate piers more strongly together, and if this thickness appear ungainly, it may be modified by decoration.

§ ix. We have thus arrived at the idea of a vertical frame work of subordinated bars, supported by cross bars at the necessary intervals, and the only remaining question is the method of insertion into the aperture. Whatever its form, if we merely let the ends of the bars into the voussoirs of its heading, the least settlement of the masonry would distort the arch, or push up some of its voussoirs, or break the window bars, or push them aside. Evidently our object should be to connect the window bars among themselves, so framing them together that they may give the utmost possible degree of support to the whole window head in case of any settlement.

But we know how to do this already: our window bars are nothing but small shafts. Capital them; throw small arches across between the smaller bars, large arches over them between the larger bars, one comprehensive arch over the whole, or else a horizontal lintel, if the window have a flat head; and we have a complete system of mutual support, independent of the aperture head, and yet assisting to sustain it, if need be. But we want the spandrils of this arch system to be themselves as light, and to let as much light through them, as possible: and we know already how to pierce them (Chap. XII. § VII.). We pierce them with circles; and we have, if the circles are small and the stonework strong, the traceries of Giotto and the Pisan school; if the circles are as large as possible and the bars slender, those which I have already figured and described as the only perfect traceries of the Northern Gothic.* The varieties of their design arise partly from the different size of window and consequent number of bars; partly from the different heights of their pointed arches, as well as the various positions of the window head in relation to the roof, rendering one or another arrangement better for dividing the light, and partly from æsthetic and expressional requirements, which, within certain limits, may be allowed a very important influence: for the strength of the bars is ordinarily so much greater than is absolutely necessary, that some portion of it may be gracefully sacrificed to the attainment of variety in the plans of tracery—a variety which, even within its severest limits, is perfectly endless; more especially in the pointed arch, the proportion of the tracery being in the round arch necessarily more fixed.

§ x. The circular window furnishes an exception to the common law, that the bars shall be vertical through the greater part of their length: for if they were so, they could neither have secure perpendicular footing, nor secure heading, their thrust being perpendicular to the curve of the voussoirs only in the centre of the window; therefore, a small circle, like the axle of a wheel, is put into the centre of the window, large enough to give footing to the necessary number of radi-

* "Seven Lamps." p. 60.

ating bars ; and the bars are arranged as spokes, being all of course properly capited and arch-headed. This is the best form of tracery for circular windows, naturally enough called wheel windows when so filled.

§ XI. Now, I wish the reader especially to observe that we have arrived at these forms of perfect Gothic tracery without the smallest reference to any practice of any school, or to any law of authority whatever. They are forms having essentially nothing whatever to do either with Goths or Greeks. They are eternal forms, based on laws of gravity and cohesion ; and no better, nor any others so good, will ever be invented, so long as the present laws of gravity and cohesion subsist.

§ XII. It does not at all follow that this group of forms owes its origin to any such course of reasoning as that which has now led us to it. On the contrary, there is not the smallest doubt that tracery began, partly, in the grouping of windows together (subsequently enclosed within a large arch*), and partly in the fantastic penetrations of a single slab of stones under the arch, as the circle in Plate V. above. The perfect form seems to have been accidentally struck in passing from experiment on the one side, to affectation on the other ; and it was so far from ever becoming systematised, that I am aware of no type of tracery for which a *less* decided preference is shown in the buildings in which it exists. The early pierced tracteries are multitudinous and perfect in their kind,—the late Flamboyant, luxuriant in detail, and lavish in quantity,—but the perfect forms exist in comparatively few churches, generally in portions of the church only, and are always connected, and that closely, either with the massy forms out of which they have emerged, or with the enervated types into which they are instantly to degenerate.

§ XIII. Nor indeed are we to look upon them as in all points

* On the north side of the nave of the cathedral of Lyons, there is an early French window, presenting one of the usual groups of foliated arches and circles, left, as it were, loose, without any enclosing curve. The effect is very painful. This remarkable window is associated with others of the common form.

superior to the more ancient examples. We have above conducted our reasoning entirely on the supposition that a single aperture is given, which it is the object to fill with glass, diminishing the power of the light as little as possible. But there are many cases, as in triforium and cloister lights, in which glazing is not required ; in which, therefore, the bars, if there be any, must have some more important function than that of merely holding glass, and in which their actual use is to give steadiness and *tone*, as it were, to the arches and walls above and beside them ; or to give the idea of protection to those who pass along the triforium, and of seclusion to those who walk in the cloister. Much thicker shafts, and more massy arches, may be properly employed in work of this kind ; and many groups of such tracery will be found resolvable into true colonnades, with the arches in pairs, or in triple or quadruple groups, and with small rosettes pierced above them for light. All this is just as *right* in its place, as the glass tracery is in its own function, and often much more grand. But the same indulgence is not to be shown to the affectations which succeeded the developed forms. Of these there are three principal conditions : the Flamboyant of France, the Stump tracery of Germany, and the Perpendicular of England.

§ xiv. Of these the first arose, by the most delicate and natural transitions, out of the perfect school. It was an endeavor to introduce more grace into its lines, and more change into its combinations ; and the æsthetic results are so beautiful, that for some time after the right road had been left, the aberration was more to be admired than regretted. The final conditions became fantastic and effeminate, but, in the country where they had been invented, never lost their peculiar grace until they were replaced by the Renaissance. The copies of the school in England and Italy have all its faults and none of its beauties ; in France, whatever it lost in method or in majesty, it gained in fantasy : literally Flamboyant, it breathed away its strength into the air ; but there is not more difference between the commonest doggerel that ever broke prose into unintelligibility, and the burning mystery

of Coleridge, or spirituality of Elizabeth Barrett, than there is between the dissolute dulness of English Flamboyant, and the flaming undulations of the wreathed lines of delicate stone, that confuse themselves with the clouds of every morning sky that brightens above the valley of the Seine.

§ xv. The second group of traceries, the intersectional or German group, may be considered as including the entire range of the absurd forms which were invented in order to display dexterity in stone-cutting and ingenuity in construction. They express the peculiar character of the German mind, which cuts the frame of every truth joint from joint, in order to prove the edge of its instruments; and, in all cases, prefers a new or a strange thought to a good one, and a subtle thought to a useful one. The point and value of the German tracery consists principally in turning the features of good traceries upside down, and cutting them in two where they are properly continuous. To destroy at once foundation and membership, and suspend everything in the air, keeping out of sight, as far as possible, the evidences of a beginning and the probabilities of an end, are the main objects of German architecture, as of modern German divinity.

§ xvi. This school has, however, at least the merit of ingenuity. Not so the English Perpendicular, though a very curious school also in *its* way. In the course of the reasoning which led us to the determination of the perfect Gothic tracery, we were induced successively to reject certain methods of arrangement as weak, dangerous, or disagreeable. Collect all these together, and practise them at once, and you have the English Perpendicular.

As thus. You find in the first place (§ v.), that your tracery bars are to be subordinated, less to greater; so you take a group of, suppose, eight, which you make all exactly equal, giving you nine equal spaces in the window, as at A, Fig. XLVI. You found, in the second place (§ vii.), that there was no occasion for more than two cross bars; so you take at least four or five (also represented at A, Fig. XLVI.), also carefully equalised, and set at equal spaces. You found, in the third place (§ viii.), that these bars were to be strength-

ened, in order to support the main piers; you will therefore cut the ends off the uppermost, and the fourth into three pieces (as also at A). In the fourth place, you found (§ ix.) that you were never to run a vertical bar into the arch head; so you run them all into it (as at B, Fig. XLVI.): and this last arrangement will be useful in two ways, for it will not only expose both the bars and the archivolt to an apparent probability of every species of dislocation at any moment, but it will provide you with two pleasing interstices at the flanks, in the shape of carving-knives, *a*, *b*, which, by throwing across

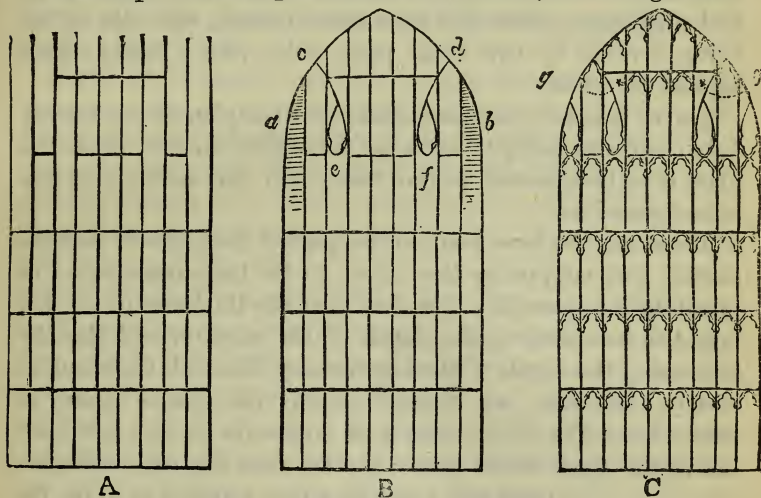

FIG. XLVI.

the curves *c*, *d*, you may easily multiply into four; and these, as you can put nothing into their sharp tops, will afford you a more than usually rational excuse for a little bit of Germanism, in filling them with arches upside down, *e*, *f*. You will now have left at your disposal two and forty similar interstices, which, for the sake of variety, you will proceed to fill with two and forty similar arches: and, as you were told that the moment a bar received an arch heading, it was to be treated as a shaft and capitalled, you will take care to give your bars no capitals nor bases, but to run bars, foliations and all, well into each other after the fashion of cast-iron, as

at C. You have still two triangular spaces occurring in an important part of your window, *g, g*, which, as they are very conspicuous, and you cannot make them uglier than they are, you will do wisely to let alone;—and you will now have the west window of the cathedral of Winchester, a very perfect example of English Perpendicular. Nor do I think that you can, on the whole, better the arrangement, unless, perhaps, by adding buttresses to some of the bars, as is done in the cathedral at Gloucester; these buttresses having the double advantage of darkening the window when seen from within, and suggesting, when it is seen from without, the idea of its being divided by two stout party walls, with a heavy thrust against the glass.

§ XVII. Thus far we have considered the plan of the tracery only: we have lastly to note the conditions under which the glass is to be attached to the bars; and the sections of the bars themselves.

These bars we have seen, in the perfect form, are to become shafts; but, supposing the object to be the admission of as much light as possible, it is clear that the thickness of the bar ought to be chiefly in the depth of the window, and that by increasing the depth of the bar we may diminish its breadth: clearly, therefore, we should employ the double group of shafts, *b*, of Fig. XIV., setting it edgeways in the window: but as the glass would then come between the two shafts, we

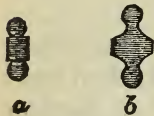

FIG. XLVII.

must add a member into which it is to be fitted, as at *a*, Fig. XLVII., and uniting these three members together in the simplest way, with a curved instead of a sharp recess behind the shafts, we have the section *b*, the perfect, but simplest type of the main tracery bars in

good Gothic. In triforium and cloister tracery, which has no glass to hold, the central member is omitted, and we have either the pure double shaft, always the most graceful, or a single and more massy shaft, which is the simpler and more usual form.

§ XVIII. Finally: there is an intermediate arrangement between the glazed and the open tracery, that of the domestic

traceries of Venice. Peculiar conditions, hereafter to be described, require the shafts of these traceries to become the main vertical supports of the floors and walls. Their thickness is therefore enormous ; and yet free egress is required between them (into balconies) which is obtained by doors in their lattice glazing. To prevent the inconvenience and ugliness of driving the hinges and fastenings of them into the shafts, and having the play of the doors in the intervals, the entire glazing is thrown behind the pillars, and attached to their abaci and bases with iron. It is thus securely sustained by their massy bulk, and leaves their symmetry and shade undisturbed.

§. xix. The depth at which the glass should be placed, in windows without traceries, will generally be fixed by the forms of their bevelling, the glass occupying the narrowest interval ; but when its position is not thus fixed, as in many London houses, it is to be remembered that the deeper the glass is set (the wall being of given thickness), the more light will enter, and the clearer the prospect will be to a person sitting quietly in the centre of the room ; on the contrary, the farther out the glass is set, the more convenient the window will be for a person rising and looking out of it. The one, therefore, is an arrangement for the idle and curious, who care only about what is going on upon the earth : the other for those who are willing to remain at rest, so that they have free admission of the light of Heaven. This might be noted as a curious expressional reason for the necessity (of which no man of ordinary feeling would doubt for a moment) of a deep recess in the window, on the outside, to all good or architectural effect : still, as there is no reason why people should be made idle by having it in their power to look out of window, and as the slight increase of light or clearness of view in the centre of a room is more than balanced by the loss of space, and the greater chill of the nearer glass and outside air, we can, I fear, allege no other structural reason for the picturesque external recess, than the expediency of a certain degree of protection, for the glass, from the brightest glare of sunshine, and heaviest rush of rain.

CHAPTER XVIII.

PROTECTION OF APERTURE.

§ I. WE have hitherto considered the aperture as merely pierced in the thickness of the walls ; and when its masonry is simple and the fillings of the aperture are unimportant, it may well remain so. But when the fillings are delicate and of value, as in the case of colored glass, finely wrought tracery, or sculpture, such as we shall often find occupying the tympanum of doorways, some protection becomes necessary against the run of the rain down the walls, and back by the bevel of the aperture to the joints or surface of the fillings.

§ II. The first and simplest mode of obtaining this is by channelling the jambs and arch head ; and this is the chief practical service of aperture mouldings, which are otherwise entirely decorative. But as this very decorative character renders them unfit to be made channels for rain water, it is well to add some external roofing to the aperture, which may protect it from the run of all the rain, except that which necessarily beats into its own area. This protection, in its most usual form, is a mere dripstone moulding carried over or round the head of the aperture. But this is, in reality, only a contracted form of a true *roof*, projecting from the wall over the aperture ; and all protections of apertures whatsoever are to be conceived as portions of small roofs, attached to the wall behind ; and supported by it, so long as their scale admits of their being so with safety, and afterwards in such manner as may be most expedient. The proper forms of these, and modes of their support, are to be the subject of our final enquiry.

§ III. Respecting their proper form we need not stay long in doubt. A deep gable is evidently the best for throwing off rain ; even a low gable being better than a high arch. Flat roofs, therefore, may only be used when the nature of the building renders the gable unsightly ; as when there is not room for it between the stories ; or when the object is rather

shade than protection from rain, as often in verandahs and balconies. But for general service the gable is the proper and natural form, and may be taken as representative of the rest. Then this gable may either project unsupported from the wall, *a*, Fig. XLVIII., or be carried by brackets or spurs, *b*, or by walls or shafts, *c*, which shafts or walls may themselves be, in windows, carried on a sill; and this, in its turn, supported by brackets or spurs. We shall glance at the applications of each of these forms in order.

§ iv. There is not much variety in the case of the first, *a*, Fig. XLVIII. In the Cumberland and border cottages the door is generally protected by two pieces of slate arranged in a gable, giving the purest possible type of the first form. In elaborate architecture such a projection hardly ever occurs, and in large architecture cannot with safety occur, without brackets; but by cutting away the greater part of the projection,

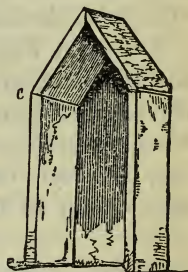

FIG. XLVIII.



FIG. XLIX.

we shall arrive at the idea of a plain gabled cornice, of which a perfect example will be found in Plate VII. of the folio series. With this first complete form we may associate the rude, single, projecting, pent-house roof; imperfect, because either it must be level and the water lodge lazily upon it, or throw off the drip upon the persons entering.

§ v. 2. *b*, Fig. XLVIII. This is a most beautiful and natural type, and is found in all good architecture, from the highest to the most humble: it is a frequent form of cottage door,

more especially when carried on spurs, being of peculiarly easy construction in wood : as applied to large architecture, it can evidently be built, in its boldest and simplest form, either of wood only, or on a scale which will admit of its sides being each a single slab of stone. If so large as to require jointed masonry, the gabled sides will evidently require support, and an arch must be thrown across under them, as in Fig. XLIX., from Fiesole.

If we cut the projection gradually down, we arrive at the common Gothic gable dripstone carried on small brackets, carved into bosses, heads, or some other ornamental form ; the sub-arch in such case being useless, is removed or coincides with the arch head of the aperture.

§ VI. 3. *c*, Fig. XLVIII. Substituting walls or pillars for the brackets, we may carry the projection as far out as we choose, and form the perfect porch, either of the cottage or village church, or of the cathedral. As we enlarge the structure, however, certain modifications of form become necessary, owing to the increased boldness of the required sup-

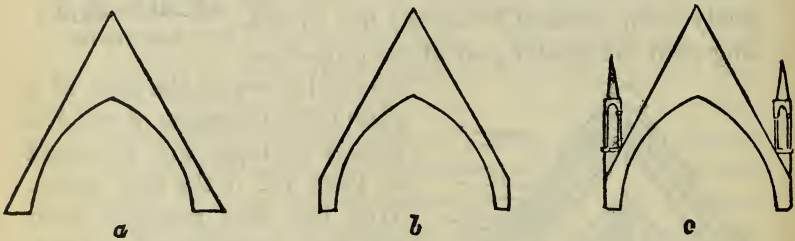

FIG. L.

porting arch. For, as the lower end of the gabled roof and of the arch cannot coincide, we have necessarily above the shafts one of the two forms *a* or *b*, in Fig. L., of which the latter is clearly the best, requiring less masonry and shorter roofing ; and when the arch becomes so large as to cause a heavy lateral thrust, it may become necessary to provide for its farther safety by pinnacles, *c*.

This last is the perfect type of aperture protection. None other can ever be invented so good. It is that once employed

by Giotto in the cathedral of Florence, and torn down by the proveditore, Benedetto Uguecione, to erect a Renaissance front instead ; and another such has been destroyed, not long since, in Venice, the porch of the church of St. Apollinare, also to put up some Renaissance upholstery : for Renaissance, as if it were not nuisance enough in the mere fact of its own existence, appears invariably as a beast of prey, and founds itself on the ruin of all that is best and noblest. Many such porches, however, happily still exist in Italy, and are among its principal glories.

§ VII. When porches of this kind, carried by walls, are placed close together, as in cases where there are many and large entrances to a cathedral front, they would, in their general form, leave deep and uncomfortable intervals, in which damp would lodge and grass grow ; and there would be a painful feeling in approaching the door in the midst of a crowd, as if some of them might miss the real doors, and be driven into the intervals, and embayed there. Clearly it will be a natural and right expedient, in such cases, to open the walls of the porch wider, so that they may correspond in slope, or nearly so, with the bevel of the doorway, and either meet each other in the intervals, or have the said intervals closed up with an intermediate wall, so that nobody may get embayed in them. The porches will thus be united, and form one range of great open gulphs or caverns, ready to receive all comers, and direct the current of the crowd into the narrower entrances. As the lateral thrust of the arches is now met by each other, the pinnacles, if there were any, must be removed, and water-spouts placed between each arch to discharge the double drainage of the gables. This is the form of all the noble northern porches, without exception, best represented by that of Rheims.

§ VIII. Contracted conditions of the pinnacle porch are beautifully used in the doors of the cathedral of Florence ; and the entire arrangement, in its most perfect form, as adapted to window protection and decoration, is applied by Giotto with inconceivable exquisiteness in the windows of the campanile ; those of the cathedral itself being all of the same

type. Various singular and delightful conditions of it are applied in Italian domestic architecture (in the Broletto of Monza very quaintly), being associated with balconies for speaking to the people, and passing into pulpits. In the north we glaze the sides of such projections, and they become bow-windows, the shape of roofing being then nearly immaterial and very fantastic, often a conical cap. All these conditions of window protection, being for real service, are endlessly delightful (and I believe the beauty of the balcony, protected by an open canopy supported by light shafts, never yet to have been properly worked out). But the Renaissance architects destroyed all of them, and introduced the magnificent and witty Roman invention of a model of a Greek pediment, with its cornices of monstrous thickness, bracketed up above the window. The horizontal cornice of the pediment is thus useless, and of course, therefore, retained; the protection to the head of the window being constructed on the principle of a hat with its crown sewn up. But the deep and dark triangular cavity thus obtained affords farther opportunity for putting ornament out of sight, of which the Renaissance architects are not slow to avail themselves.

A more rational condition is the complete pediment with a couple of shafts, or pilasters, carried on a bracketed sill; and the windows of this kind, which have been well designed, are perhaps the best things which the Renaissance schools have produced: those of Whitehall are, in their way, exceedingly beautiful; and those of the Palazzo Ricardi at Florence, in their simplicity and sublimity, are scarcely unworthy of their reputed designer, Michael Angelo.

CHAPTER XIX.

SUPERIMPOSITION.

§ I. THE reader has now some knowledge of every feature of all possible architecture. Whatever the nature of the building which may be submitted to his criticism, if it be an edifice at all, if it be anything else than a mere heap of stones

like a pyramid or breakwater, or than a large stone hewn into shape, like an obelisk, it will be instantly and easily resolvable into some of the parts which we have been hitherto considering: its pinnacles will separate themselves into their small shafts and roofs; its supporting members into shafts and arches, or walls penetrated by apertures of various shape, and supported by various kinds of buttresses. Respecting each of these several features I am certain that the reader feels himself prepared, by understanding their plain function, to form something like a reasonable and definite judgment, whether they be good or bad; and this right judgment of parts will, in most cases, lead him to just reverence or condemnation of the whole.

§ II. The various modes in which these parts are capable of combination, and the merits of buildings of different form and expression, are evidently not reducible into lists, nor to be estimated by general laws. The nobility of each building depends on its special fitness for its own purposes; and these purposes vary with every climate, every soil, and every national custom: nay, there were never, probably, two edifices erected in which some accidental difference of condition did not require some difference of plan or of structure; so that, respecting plan and distribution of parts, I do not hope to collect any universal law of right; but there are a few points necessary to be noticed respecting the means by which height is attained in buildings of various plans, and the expediency and methods of superimposition of one story or tier of architecture above another.

§ III. For, in the preceding inquiry, I have always supposed either that a single shaft would reach to the top of the building, or that the farther height required might be added in plain wall above the heads of the arches; whereas it may often be rather expedient to complete the entire lower series of arches, or finish the lower wall, with a bold string course or cornice, and build another series of shafts, or another wall, on the top of it.

§ IV. This superimposition is seen in its simplest form in the interior shafts of a Greek temple; and it has been largely

used in nearly all countries where buildings have been meant for real service. Outery has often been raised against it, but the thing is so sternly necessary that it has always forced itself into acceptance ; and it would, therefore, be merely losing time to refute the arguments of those who have attempted its disparagement. Thus far, however, they have reason on their side, that if a building can be kept in one grand mass, without sacrificing either its visible or real adaptation to its objects, it is not well to divide it into stories until it has reached proportions too large to be justly measured by the eye. It ought then to be divided in order to mark its bulk ; and decorative divisions are often possible, which rather increase than destroy the expression of general unity.

§ v. Superimposition, wisely practised, is of two kinds, directly contrary to each other, of weight on lightness, and of lightness on weight ; while the superimposition of weight on weight, or lightness on lightness, is nearly always wrong.

1. Weight on lightness : I do not say weight on *weakness*. The superimposition of the human body on its limbs I call weight on lightness : the superimposition of the branches on a tree trunk I call lightness on weight : in both cases the support is fully adequate to the work, the form of support being regulated by the differences of requirement. Nothing in architecture is half so painful as the apparent want of sufficient support when the weight above is visibly passive : for all buildings are not passive ; some seem to rise by their own strength, or float by their own buoyancy ; a dome requires no visibility of support, one fancies it supported by the air. But passive architecture without help for its passiveness is unendurable. In a lately built house, No. 86, in Oxford Street, three huge stone pillars in the second story are carried apparently by the edges of three sheets of plate glass in the first. I hardly know anything to match the painfulness of this and some other of our shop structures, in which the iron-work is concealed ; nor, even when it is apparent, can the eye ever feel satisfied of their security, when built, as at present, with fifty or sixty feet of wall above a rod of iron not the width of this page.

§ VI. The proper forms of this superimposition of weight on lightness have arisen, for the most part, from the necessity or desirableness, in many situations, of elevating the inhabited portions of buildings considerably above the ground level, especially those exposed to damp or inundation, and the consequent abandonment of the ground story as un-serviceable, or else the surrender of it to public purposes. Thus, in many market and town houses, the ground story is left open as a general place of sheltered resort, and the enclosed apartments raised on pillars. In almost all warm countries the luxury, almost the necessity, of arcades to protect the passengers from the sun, and the desirableness of large space in the rooms above, lead to the same construction. Throughout the Venetian islet group, the houses seem to have been thus, in the first instance, universally built, all the older palaces appearing to have had the *rez de chaussée* perfectly open, the upper parts of the palace being sustained on magnificent arches, and the smaller houses sustained in the same manner on wooden piers, still retained in many of the cortiles, and exhibited characteristically throughout the main street of Murano. As ground became more valuable and house-room more scarce, these ground-floors were enclosed with wall veils between the original shafts, and so remain; but the type of the structure of the entire city is given in the Ducal Palace.

§ VII. To this kind of superimposition we owe the most picturesque street effects throughout the world, and the most graceful, as well as the most grotesque, buildings, from the many-shafted fantasy of the Alhambra (a building as beautiful in disposition as it is base in ornamentation) to the four-legged stolidity of the Swiss Chalet: * nor these only, but great part of the effect of our cathedrals, in which, necessarily, the close

* I have spent much of my life among the Alps; but I never pass, without some feeling of new surprise, the Chalet, standing on its four pegs (each topped with a flat stone), balanced in the fury of Alpine winds. It is not, perhaps, generally known that the chief use of the arrangement is not so much to raise the building above the snow, as to get a draught of wind beneath it, which may prevent the drift from rising against its sides.

triforium and clerestory walls are superimposed on the nave piers ; perhaps with most majesty where with greatest simplicity, as in the old basilican types, and the noble cathedral of Pisa.

§ VIII. In order to the delightfulness and security of all such arrangements, this law must be observed :—that in proportion to the height of wall above them, the shafts are to be short. You may take your given height of wall, and turn any quantity of that wall into shaft that you like ; but you must not turn it all into tall shafts, and then put more wall above. Thus, having a house five stories high, you may turn the lower story into shafts, and leave the four stories in wall ; or the two lower stories into shafts, and leave three in wall ; but, whatever you add to the shaft, you must take from the wall. Then also, of course, the shorter the shaft the thicker will be its *proportionate*, if not its actual, diameter. In the Ducal Palace of Venice the shortest shafts are always the thickest.*

§ IX. The second kind of superimposition, lightness on weight, is, in its most necessary use, of stories of houses one upon another, where, of course, wall veil is required in the lower ones, and has to support wall veil above, aided by as much of shaft structure as is attainable within the given limits. The greatest, if not the only, merit of the Roman and Renaissance Venetian architects is their graceful management of this kind of superimposition ; sometimes of complete courses of external arches and shafts one above the other ; sometimes of apertures with intermediate cornices at the levels of the floors, and large shafts from top to bottom of the building ; always observing that the upper stories shall be at once lighter and richer than the lower ones. The entire value of such buildings depends upon the perfect and easy expression of the relative strength of the stories, and the unity obtained by the varieties of their proportions, while yet the fact of superimposition and separation by floors is frankly told.

§ X. In churches and other buildings in which there is no separation by floors, another kind of pure shaft superimposition

* Appendix 20, "Shafts of the Ducal Palace."

is often used, in order to enable the builder to avail himself of short and slender shafts. It has been noted that these are often easily attainable, and of precious materials, when shafts large enough and strong enough to do the work at once, could not be obtained except at unjustifiable expense, and of coarse stone. The architect has then no choice but to arrange his work in successive stories ; either frankly completing the arch work and cornice of each, and beginning a new story above it, which is the honester and nobler way, or else tying the stories together by supplementary shafts from floor to roof,—the general practice of the Northern Gothic, and one which, unless most gracefully managed, gives the look of a scaffolding, with cross-poles tied to its uprights, to the whole clerestory wall. The best method is that which avoids all chance of the upright shafts being supposed continuous, by increasing their number and changing their places in the upper stories, so that the whole work branches from the ground like a tree. This is the superimposition of the Byzantine and the Pisan Romanesque ; the most beautiful examples of it being, I think, the Southern portico of St. Mark's, the church of S. Giovanni at Pistoja, and the apse of the cathedral of Pisa. In Renaissance work the two principles are equally distinct, though the shafts are (I think) always one above the other. The reader may see one of the best examples of the separately superimposed story in Whitehall (and another far inferior in St. Paul's), and by turning himself round at Whitehall may compare with it the system of connecting shafts in the Treasury ; though this is a singularly bad example, the window cornices of the first floor being like shelves in a cupboard, and cutting the mass of the building in two, in spite of the pillars.

§ xi. But this superimposition of lightness on weight is still more distinctly the system of many buildings of the kind which I have above called Architecture of Position, that is to say, architecture of which the greater part is intended merely to keep something in a peculiar position ; as in light-houses, and many towers and belfries. The subject of spire and tower architecture, however, is so interesting and extensive, that I have thoughts of writing a detached essay upon it, and, at all

events, cannot enter upon it here : but this much is enough for the reader to note for our present purpose, that, although many towers do in reality stand on piers or shafts, as the central towers of cathedrals, yet the expression of all of them, and the real structure of the best and strongest, are the elevation of gradually diminishing weight on massy or even solid foundation. Nevertheless, since the tower is in its origin a building for strength of defence, and faithfulness of watch, rather than splendor of aspect, its true expression is of just so much diminution of weight upwards as may be necessary to its fully balanced strength, not a jot more. There must be no light-headedness in your noble tower : impregnable foundation, wrathful crest, with the vizor down, and the dark vigilance seen through the clefts of it ; not the filigree crown or embroidered cap. No towers are so grand as the square-browed ones, with massy cornices and rent battlements : next to these come the fantastic towers, with their various forms of steep roof ; the best, not the cone, but the plain gable thrown very high ; last of all in my mind (of good towers), those with spires or crowns, though these, of course, are fittest for ecclesiastical purposes, and capable of the richest ornament. The paltry four or eight pinnacled things we call towers in England (as in York Minster), are mere confectioner's Gothic, and not worth classing.

§ XII. But, in all of them, this I believe to be a point of chief necessity,—that they shall seem to stand, and shall verily stand, in their own strength ; not by help of buttresses nor artful balancings on this side and on that. Your noble tower must need no help, must be sustained by no crutches, must give place to no suspicion of decrepitude. Its office may be to withstand war, look forth for tidings, or to point to heaven : but it must have in its own walls the strength to do this ; it is to be itself a bulwark, not to be sustained by other bulwarks ; to rise and look forth, “ the tower of Lebanon that looketh toward Damascus,” like a stern sentinel, not like a child held up in its nurse's arms. A tower may, indeed, have a kind of buttress, a projection, or subordinate tower at each of its angles ; but these are to its main body like the satellites to a

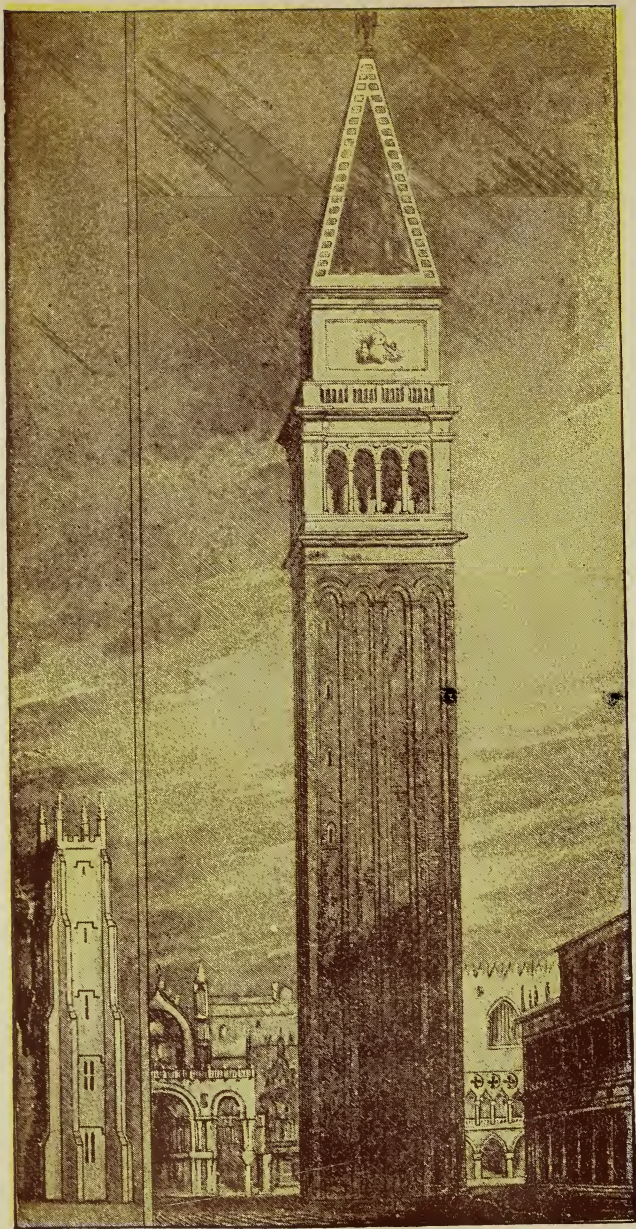

PLATE VI.—TYPES OF TOWERS.

shaft, joined with its strength, and associated in its uprightness, part of the tower itself: exactly in the proportion in which they lose their massive unity with its body and assume the form of true buttress walls set on its angles, the tower loses its dignity.

§ XIII. These two characters, then, are common to all noble towers, however otherwise different in purpose or feature,—the first, that they rise from massy foundation to lighter summits, frowning with battlements perhaps, but yet evidently more pierced and thinner in wall than beneath, and, in most ecclesiastical examples, divided into rich open work: the second, that whatever the form of the tower, it shall not appear to stand by help of buttresses. It follows from the first condition, as indeed it would have followed from ordinary æsthetic requirements, that we shall have continual variation in the arrangements of the stories, and the larger number of apertures towards the top,—a condition exquisitely carried out in the old Lombardic towers, in which, however small they may be, the number of apertures is always regularly increased towards the summit; generally one window in the lowest stories, two in the second, then three, five, and six; often, also, one, two, four, and six, with beautiful symmetries of placing, not at present to our purpose. We may sufficiently exemplify the general laws of tower building by placing side by side, drawn to the same scale, a mediæval tower, in which most of them are simply and unaffectedly observed, and one of our own modern towers, in which every one of them is violated, in small space, convenient for comparison. (Plate VI.)

§ XIV. The old tower is that of St. Mark's at Venice, not a very perfect example, for its top is Renaissance, but as good Renaissance as there is in Venice; and it is fit for our present purpose, because it owes none of its effect to ornament. It is built as simply as it well can be to answer its purpose: no buttresses; no external features whatever, except some huts at the base, and the loggia, afterwards built, which, on purpose, I have not drawn; one bold square mass of brickwork; double walls, with an ascending inclined plane between them, with apertures as small as possible, and these only in neces-

sary places, giving just the light required for ascending the stair or slope, not a ray more ; and the weight of the whole relieved only by the double pilasters on the sides, sustaining small arches at the top of the mass, each decorated with the scallop or cockle shell, presently to be noticed as frequent in Renaissance ornament, and here, for once, thoroughly well applied. Then, when the necessary height is reached, the belfry is left open, as in the ordinary Romanesque campanile, only the shafts more slender, but severe and simple, and the whole crowned by as much spire as the tower would carry, to render it more serviceable as a landmark. The arrangement is repeated in numberless campaniles throughout Italy.

§ xv. The one beside it is one of those of the lately built college at Edinburgh. I have not taken it as worse than many others (just as I have not taken the St. Mark's tower as better than many others) ; but it happens to compress our British system of tower building into small space. The Venetian tower rises 350 feet,* and has no buttresses, though built of brick ; the British tower rises 121 feet, and is built of stone, but is supposed to be incapable of standing without two huge buttresses on each angle. The St. Mark's tower has a high sloping roof, but carries it simply, requiring no pinnacles at its angles ; the British tower has no visible roof, but has four pinnacles for mere ornament. The Venetian tower has its lightest part at the top, and is massy at the base ; the British tower has its lightest part at the base, and shuts up its windows into a mere arrowslit at the top. What the tower was built for at all must therefore, it seems to me, remain a mystery to every beholder ; for surely no studious inhabitant of its upper chambers will be conceived to be pursuing his employments by the light of the single chink on each side ; and, had it been intended for a belfry, the sound of its bells would

* I have taken Professor Willis's estimate ; there being discrepancy among various statements. I did not take the trouble to measure the height myself, the building being one which does not come within the range of our future inquiries ; and its exact dimensions, even here, are of no importance as respects the question at issue.

have been as effectually prevented from getting out, as the light from getting in.

§ xvi. In connexion with the subject of towers and of superimposition, one other feature, not conveniently to be omitted from our house-building, requires a moment's notice, --the staircase.

In modern houses it can hardly be considered an architectural feature, and is nearly always an ugly one, from its being apparently without support. And here I may not unfitly note the important distinction, which perhaps ought to have been dwelt upon in some places before now, between the *marvellous* and the *perilous* in apparent construction. There are many edifices which are awful or admirable in their height, and lightness, and boldness of form, respecting which, nevertheless, we have no fear that they should fall. Many a mighty dome and aerial aisle and arch may seem to stand, as I said, by miracle, but by steadfast miracle notwithstanding; there is no fear that the miracle should cease. We have a sense of inherent power in them, or, at all events, of concealed and mysterious provision for their safety. But in leaning towers, as of Pisa or Bologna, and in much minor architecture, passive architecture, of modern times, we feel that there is but a chance between the building and destruction; that there is no miraculous life in it, which animates it into security, but an obstinate, perhaps vain, resistance to immediate danger. The appearance of this is often as strong in small things as in large; in the sounding-boards of pulpits, for instance, when sustained by a single pillar behind them, so that one is in dread, during the whole sermon, of the preacher being crushed if a single nail should give way; and again, the modern geometrical unsupported staircase. There is great disadvantage, also, in the arrangement of this latter, when room is of value; and excessive ungracefulness in its awkward divisions of the passage walls, or windows. In mediæval architecture, where there was need of room, the staircase was spiral, and enclosed generally in an exterior tower, which added infinitely to the picturesque effect of the building; nor was the stair itself steeper nor less commodious than the ordinary compressed

straight staircase of a modern dwelling-house. Many of the richest towers of domestic architecture owe their origin to this arrangement. In Italy the staircase is often in the open air, surrounding the interior court of the house, and giving access to its various galleries or loggias : in this case it is almost always supported by bold shafts and arches, and forms a most interesting additional feature of the cortile, but presents no peculiarity of construction requiring our present examination.

We may here, therefore, close our inquiries into the subject of construction ; nor must the reader be dissatisfied with the simplicity or apparent barrenness of their present results. He will find, when he begins to apply them, that they are of more value than they now seem ; but I have studiously avoided letting myself be drawn into any intricate question, because I wished to ask from the reader only so much attention as it seemed that even the most indifferent would not be unwilling to pay to a subject which is hourly becoming of greater practical interest. Evidently it would have been altogether beside the purpose of this essay to have entered deeply into the abstract science, or closely into the mechanical detail, of construction : both have been illustrated by writers far more capable of doing so than I, and may be studied at the reader's discretion ; all that has been here endeavored was the leading him to appeal to something like definite principle, and refer to the easily intelligible laws of convenience and necessity, whenever he found his judgment likely to be overborne by authority on the one hand, or dazzled by novelty on the other. If he has time to do more, and to follow out in all their brilliancy the mechanical inventions of the great engineers and architects of the day, I, in some sort, envy him, but must part company with him : for my way lies not along the viaduct, but down the quiet valley which its arches cross, nor through the tunnel, but up the hill-side which its cavern darkens, to see what gifts Nature will give us, and with what imagery she will fill our thoughts, that the stones we have ranged in rude order may now be touched with life ; nor lose for ever, in their hewn nakedness, the voices they had of old, when the

valley streamlet eddied round them in palpitating light, and the winds of the hill-side shook over them the shadows of the fern.

CHAPTER XX.

THE MATERIAL OF ORNAMENT.

§ I. WE enter now on the second division of our subject. We have no more to do with heavy stones and hard lines ; we are going to be happy : to look round in the world and discover (in a serious manner always, however, and under a sense of responsibility) what we like best in it, and to enjoy the same at our leisure : to gather it, examine it, fasten all we can of it into imperishable forms, and put it where we may see it for ever.

This is to decorate architecture.

§ II. There are, therefore, three steps in the process : first, to find out in a grave manner what we like best ; secondly, to put as much of this as we can (which is little enough) into form ; thirdly, to put this formed abstraction into a proper place.

And we have now, therefore, to make these three inquiries in succession first, what we like, or what is the right material of ornament ; then how we are to present it, or its right treatment ; then, where we are to put it, or its right place. I think I can answer that first inquiry in this Chapter, the second inquiry in the next Chapter, and the third I shall answer in a more diffusive manner, by taking up in succession the several parts of architecture above distinguished, and rapidly noting the kind of ornament fittest for each.

§ III. I said in chapter II. § XIV., that all noble ornamentation was the expression of man's delight in God's work. This implied that there was an ignoble ornamentation, which was the expression of man's delight in his *own*. There is such a school, chiefly degraded classic and Renaissance, in which the ornament is composed of imitations of things made by man. I think, before inquiring what we like best of God's work, we

had better get rid of all this imitation of man's, and be quite sure we do not like *that*.

§ iv. We shall rapidly glance, then, at the material of decoration hence derived. And now I cannot, as I before have done respecting construction, *convince* the reader of one thing being wrong, and another right. I have confessed as much again and again ; I am now only to make appeal to him, and cross-question him, whether he really does like things or not. If he likes the ornament on the base of the column of the Place Vendôme, composed of Wellington boots and laced frock coats, I cannot help it ; I can only say I differ from him, and don't like it. And if, therefore, I speak dictatorially, and say this is base, or degraded, or ugly, I mean only that I believe men of the longest experience in the matter would either think it so, or would be prevented from thinking it so only by some morbid condition of their minds ; and I believe that the reader, if he examine himself candidly, will usually agree in my statements.

§ v. The subjects of ornament found in man's work may properly fall into four heads : 1. Instruments of art, agriculture, and war ; armor, and dress ; 2. Drapery ; 3. Shipping ; 4. Architecture itself.

1. Instruments, armor, and dress.

The custom of raising trophies on pillars, and of dedicating arms in temples, appears to have first suggested the idea of employing them as the subjects of sculptural ornament : thenceforward, this abuse has been chiefly characteristic of classical architecture, whether true or Renaissance. Armor is a noble thing in its proper service and subordination to the body ; so is an animal's hide on its back ; but a heap of cast skins, or of shed armor, is alike unworthy of all regard or imitation. We owe much true sublimity, and more of delightful picturesqueness, to the introduction of armor both in painting and sculpture : in poetry it is better still,—Homer's undressed Achilles is less grand than his crested and shielded Achilles, though Phidias would rather have had him naked ; in all mediæval painting, arms, like all other parts of costume, are treated with exquisite care and delight ; in the designs of Leonardo,

Raffaello, and Perugino, the armor sometimes becomes almost too conspicuous from the rich and endless invention bestowed upon it ; while Titian and Rubens seek in its flash what the Milanese and Perugian sought in its form, sometimes subordinating heroism to the light of the steel, while the great designers wearied themselves in its elaborate fancy.

But all this labor was given to the living, not the dead armor ; to the shell with its animal in it, not the cast shell of the beach ; and even so, it was introduced more sparingly by the good sculptors than the good painters ; for the former felt, and with justice, that the painter had the power of conquering the over prominence of costume by the expression and color of the countenance, and that by the darkness of the eye, and glow of the cheek, he could always conquer the gloom and the flash of the mail ; but they could hardly, by any boldness or energy of the marble features, conquer the forwardness and conspicuousness of the sharp armorial forms. Their armed figures were therefore almost always subordinate, their principal figures draped or naked, and their choice of subject was much influenced by this feeling of necessity. But the Renaissance sculptors displayed the love of a Camilla for the mere crest and plume. Paltry and false alike in every feeling of their narrowed minds, they attached themselves, not only to costume without the person, but to the pettiest details of the costume itself. They could not describe Achilles, but they could describe his shield ; a shield like those of dedicated spoil, without a handle, never to be waved in the face of war. And then we have helmets and lances, banners and swords, sometimes with men to hold them, sometimes without ; but always chiselled with a tailor-like love of the chasing or the embroidery,—show helmets of the stage, no Vulcan work on them, no heavy hammer strokes, no Etna fire in the metal of them, nothing but pasteboard crests and high feathers. And these, cast together in disorderly heaps, or grinning vacantly over key-stones, form one of the leading decorations of Renaissance architecture, and that one of the best ; for helmets and lances, however loosely laid, are better than violins, and pipes, and books of music, which were

another of the Palladian and Sansovinian sources of ornament. Supported by ancient authority, the abuse soon became a matter of pride, and since it was easy to copy a heap of cast clothes, but difficult to manage an arranged design of human figures, the indolence of architects came to the aid of their affectation, until by the moderns we find the practice carried out to its most interesting results, and, as above noted, a large pair of boots occupying the principal place in the bas-reliefs on the base of the Colonne Vendôme.

§ VI. A less offensive, because singularly grotesque, example of the abuse at its height, occurs in the Hôtel des Invalides, where the dormer windows are suits of armor down to the bottom of the corselet, crowned by the helmet, and with the window in the middle of the breast.

Instruments of agriculture and the arts are of less frequent occurrence, except in hieroglyphics, and other work, where they are not employed as ornaments, but represented for the sake of accurate knowledge, or as symbols. Wherever they have purpose of this kind, they are of course perfectly right; but they are then part of the building's conversation, not conducive to its beauty. The French have managed, with great dexterity, the representation of the machinery for the elevation of their Luxor obelisk, now sculptured on its base.

§ VII. 2. Drapery. I have already spoken of the error of introducing drapery, as such, for ornament, in the "Seven Lamps." I may here note a curious instance of the abuse in the church of the Jesuiti at Venice (Renaissance). On first entering you suppose that the church, being in a poor quarter of the city, has been somewhat meanly decorated by heavy green and white curtains of an ordinary upholsterer's pattern: on looking closer, they are discovered to be of marble, with the green pattern inlaid. Another remarkable instance is in a piece of not altogether unworthy architecture at Paris (Rue Rivoli), where the columns are supposed to be decorated with images of handkerchiefs tied in a stout knot round the middle of them. This shrewd invention bids fair to become a new order. Multitudes of massy curtains and various upholstery, more or less in imitation of that of the drawing-room,

are carved and gilt, in wood or stone, about the altars and other theatrical portions of Romanist churches ; but from these coarse and senseless vulgarities we may well turn, in all haste, to note, with respect as well as regret, one of the errors of the great school of Niccolo Pisano,—an error so full of feeling as to be sometimes all but redeemed, and altogether forgiven,—the sculpture, namely, of curtains around the recumbent statues upon tombs, curtains which angels are represented as withdrawing, to gaze upon the faces of those who are at rest. For some time the idea was simply and slightly expressed, and though there was always a painfulness in finding the shafts of stone, which were felt to be the real supporters of the canopy, represented as of yielding drapery, yet the beauty of the angelic figures, and the tenderness of the thought, disarmed all animadversion. But the scholars of the Pisani, as usual, caricatured when they were unable to invent ; and the quiet curtained canopy became a huge marble tent, with a pole in the centre of it. Thus vulgarised, the idea itself soon disappeared, to make room for urns, torches, and weepers, and the other modern paraphernalia of the church-yard.

§ VIII. 3. Shipping. I have allowed this kind of subject to form a separate head, owing to the importance of rostra in Roman decoration, and to the continual occurrence of naval subjects in modern monumental bas-relief. Mr. Fergusson says, somewhat doubtfully, that he perceives a “*kind of beauty*” in a ship : I say, without any manner of doubt, that a ship is one of the loveliest things man ever made, and one of the noblest ; nor do I know any lines, out of divine work, so lovely as those of the head of a ship, or even as the sweep of the timbers of a small boat, not a race boat, a mere floating chisel, but a broad, strong, sea boat, able to breast a wave and break it : and yet, with all this beauty, ships cannot be made subjects of sculpture. No one pauses in particular delight beneath the pediments of the Admiralty ; nor does scenery of shipping ever become prominent in bas-relief without destroying it : witness the base of the Nelson pillar. It may be, and must be sometimes, introduced in severe subordination to the

figure subject, but just enough to indicate the scene ; sketched in the lightest lines on the background ; never with any attempt at realisation, never with any equality to the force of the figures, unless the whole purpose of the subject be picturesque. I shall explain this exception presently, in speaking of imitative architecture.

§ ix. There is one piece of a ship's fittings, however, which may be thought to have obtained acceptance as a constant element of architectural ornament,—the cable : it is not, however, the cable itself, but its abstract form, a group of twisted lines (which a cable only exhibits in common with many natural objects), which is indeed beautiful as an ornament. Make the resemblance complete, give to the stone the threads and character of the cable, and you may, perhaps, regard the sculpture with curiosity, but never more with admiration. Consider the effect of the base of the statue of King William IV. at the end of London Bridge.

§ x. 4. Architecture itself. The erroneous use of armor, or dress, or instruments, or shipping, as decorative subject, is almost exclusively confined to bad architecture—Roman or Renaissance. But the false use of architecture itself, as an ornament of architecture, is conspicuous even in the mediæval work of the best times, and is a grievous fault in some of its noblest examples.

It is, therefore, of great importance to note exactly at what point this abuse begins, and in what it consists.

§ xi. In all bas-relief, architecture may be introduced as an explanation of the scene in which the figures act ; but with more or less prominence in the *inverse ratio of the importance of the figures*.

The metaphysical reason of this is, that where the figures are of great value and beauty, the mind is supposed to be engaged wholly with them ; and it is an impertinence to disturb its contemplation of them by any minor features whatever. As the figures become of less value, and are regarded with less intensity, accessory subjects may be introduced, such as the thoughts may have leisure for.

Thus, if the figures be as large as life, and complete statues,

it is gross vulgarity to carve a temple above them, or distribute them over sculptured rocks, or lead them up steps into pyramids : I need hardly instance Canova's works,* and the Dutch pulpit groups, with fishermen, boats, and nets, in the midst of church naves.

If the figures be in bas-relief, though as large as life, the scene may be explained by lightly traced outlines : this is admirably done in the Ninevite marbles.

If the figures be in bas-relief, or even alto-relievo, but less than life, and if their purpose is rather to enrich a space and produce picturesque shadows, than to draw the thoughts entirely to themselves, the scenery in which they act may become prominent. The most exquisite examples of this treatment are the gates of Ghiberti. What would that Madonna of the Annunciation be, without the little shrine into which she shrinks back? But all mediæval work is full of delightful examples of the same kind of treatment : the gates of hell and of paradise are important pieces, both of explanation and effect, in all early representations of the last judgment, or of the descent into Hades. The keys of St. Peter, and the crushing flat of the devil under his own door, when it is beaten in, would hardly be understood without the respective gateways above. The best of all the later capitals of the Ducal Palace of Venice depends for great part of its value on the richness of a small campanile, which is pointed to proudly by a small emperor in a turned-up hat, who, the legend informs us, is "Numa Pompilio, imperador, edificador di tempi e chiese."

§ XII. Shipping may be introduced, or rich fancy of vestments, crowns, and ornaments, exactly on the same conditions as architecture ; and if the reader will look back to my definition of the picturesque in the "Seven Lamps," he will see why I said, above, that they might only be prominent when the purpose of the subject was partly picturesque ; that is to say, when the mind is intended to derive part of its enjoyment from the parasitical qualities and accidents of the thing, not from the heart of the thing itself.

* The admiration of Canova I hold to be one of the most deadly symptoms in the civilisation of the upper classes in the present century.

And thus, while we must regret the flapping sails in the death of Nelson in Trafalgar Square, we may yet most heartily enjoy the sculpture of a storm in one of the bas-reliefs of the tomb of St. Pietro Martire in the church of St. Eustorgio at Milan, where the grouping of the figures is most fancifully complicated by the under-cut cordage of the vessel.

§ XIII. In all these instances, however, observe that the permission to represent the human work as an ornament, is conditional on its being necessary to the representation of a scene, or explanation of an action. On no terms whatever could any such subject be independently admissible.

Observe, therefore, the use of manufacture as ornament is—

1. With heroic figure sculpture, not admissible at all.
2. With picturesque figure sculpture, admissible in the degree of its picturesqueness.
3. Without figure sculpture, not admissible at all.

So also in painting: Michael Angelo, in the Sistine Chapel, would not have willingly painted a dress of figured damask or of watered satin; his was heroic painting, not admitting accessories.

Tintoret, Titian, Veronese, Rubens, and Vandyck, would be very sorry to part with their figured stuffs and lustrous silks; and sorry, observe, exactly in the degree of their picturesque feeling. Should not *we* also be sorry to have Bishop Ambrose without his vest, in that picture of the National Gallery?

But I think Vandyck would not have liked, on the other hand, the vest without the bishop. I much doubt if Titian or Veronese would have enjoyed going into Waterloo House, and making studies of dresses upon the counter.

§ XIV. So, therefore, finally, neither architecture nor any other human work is admissible as an ornament, except in subordination to figure subject. And this law is grossly and painfully violated by those curious examples of Gothic, both early and late, in the north, (but late, I think, exclusively, in Italy,) in which the minor features of the architecture were

composed of *small models* of the larger : examples which led the way to a series of abuses materially affecting the life, strength, and nobleness of the Northern Gothic,—abuses which no Ninevite, nor Egyptian, nor Greek, nor Byzantine, nor Italian of the earlier ages would have endured for an instant, and which strike me with renewed surprise whenever I pass beneath a portal of thirteenth century Northern Gothic, associated as they are with manifestations of exquisite feeling and power in other directions. The porches of Bourges, Amiens, Notre Dame of Paris, and Notre Dame of Dijon, may be noted as conspicuous in error : small models of feudal towers with diminutive windows and battlements, of cathedral spires with scaly pinnacles, mixed with temple pediments and nondescript edifices of every kind, are crowded together over the recess of the niche into a confused fool's cap for the saint below. Italian Gothic is almost entirely free from the taint of this barbarism until the Renaissance period, when it becomes rampant in the cathedral of Como and Certosa of Pavia ; and at Venice we find the Renaissance churches decorated with models of fortifications like those in the repository at Woolwich, or inlaid with mock arcades in pseudo-perspective, copied from gardeners' paintings at the ends of conservatories.

§ xv. I conclude, then, with the reader's leave, that all ornament is base which takes for its subject human work, that it is utterly base,—painful to every rightly-toned mind, without perhaps immediate sense of the reason, but for a reason palpable enough when we *do* think of it. For to carve our own work, and set it up for admiration, is a miserable self-complacency, a contentment in our own wretched doings, when we might have been looking at God's doings. And all noble ornament is the exact reverse of this. It is the expression of man's delight in God's work.

§ xvi. For observe, the function of ornament is to make you happy. Now in what are you rightly happy? Not in thinking of what you have done yourself ; not in your own pride, not your own birth ; not in your own being, or your own will, but in looking at God ; watching what He does,

what He is ; and obeying His law, and yielding yourself to His will.

You are to be made happy by ornaments ; therefore they must be the expression of all this. Not copies of your own handiwork ; not boastings of your own grandeur ; not heraldries ; not king's arms, nor any creature's arms, but God's arm, seen in His work. Not manifestation of your delight in your own laws, or your own liberties, or your own inventions ; but in divine laws, constant, daily, common laws ;—not Composite laws, nor Doric laws, nor laws of the five orders, but of the Ten Commandments.

§ xvii. Then the proper material of ornament will be whatever God has created ; and its proper treatment, that which seems in accordance with or symbolical of His laws. And, for material, we shall therefore have, first, the abstract lines which are most frequent in nature ; and then, from lower to higher, the whole range of systematised inorganic and organic forms. We shall rapidly glance in order at their kinds ; and, however absurd the elemental division of inorganic matter by the ancients may seem to the modern chemist, it is one so grand and simple for arrangements of external appearances, that I shall here follow it ; noticing first, after abstract lines, the imitable forms of the four elements, of Earth, Water, Fire, and Air, and then those of animal organisms. It may be convenient to the reader to have the order stated in a clear succession at first, thus :—

1. Abstract lines.
2. Forms of Earth (Crystals).
3. Forms of Water (Waves).
4. Forms of Fire (Flames and Rays).
5. Forms of Air (Clouds).
6. (Organic forms.) Shells.
7. Fish.
8. Reptiles and insects.
9. Vegetation (A.) Stems and Trunks.
10. Vegetation (B.) Foliage.
11. Birds.
12. Mammalian animals and Man.

It may be objected that clouds are a form of moisture, not of air. They are, however, a perfect expression of aerial states and currents, and may sufficiently well stand for the element they move in. And I have put vegetation apparently somewhat out of its place, owing to its vast importance as a means of decoration, and its constant association with birds and men.

§ XVIII. 1. Abstract lines. I have not with lines named also shades and colors, for this evident reason, that there are no such things as abstract shadows, irrespective of the forms which exhibit them, and distinguished in their own nature from each other; and that the arrangement of shadows, in greater or less quantity, or in certain harmonical successions, is an affair of treatment, not of selection. And when we use abstract colors, we are in fact using a part of nature herself,—using a quality of her light, correspondent with that of the air, to carry sound; and the arrangement of color in harmonious masses is again a matter of treatment, not selection. Yet even in this separate art of coloring, as referred to architecture, it is very notable that the best tints are always those of natural stones. These can hardly be wrong; I think I never yet saw an offensive introduction of the natural colors of marble and precious stones, unless in small mosaics, and in one or two glaring instances of the resolute determination to produce something ugly at any cost. On the other hand, I have most assuredly never yet seen a painted building, ancient or modern, which seemed to me quite right.

§ XIX. Our first constituents of ornament will therefore be abstract lines, that is to say, the most frequent contours of natural objects, transferred to architectural forms when it is not right or possible to render such forms distinctly imitative. For instance, the line or curve of the edge of a leaf may be accurately given to the edge of a stone, without rendering the stone in the least *like* a leaf, or suggestive of a leaf; and this the more fully, because the lines of nature are alike in all her works; simpler or richer in combination, but the same in character; and when they are taken out of their combinations it is impossible to say from which of her works they have been borrowed, their universal property being that of ever-varying

curvature in the most subtle and subdued transitions, with peculiar expressions of motion, elasticity, or dependence, which I have already insisted upon at some length in the chapters on typical beauty in "Modern Painters." But, that the reader may here be able to compare them for himself as deduced from different sources, I have drawn, as accurately as I can, on the opposite plate, some ten or eleven lines from natural forms of very different substances and scale : the first, *a b*, is in the original, I think, the most beautiful simple curve I have ever seen in my life ; it is a curve about three quarters of a mile long, formed by the surface of a small glacier of the second order, on a spur of the Aiguille de Blaitière (Chamouni). I have merely outlined the crags on the right of it, to show their sympathy and united action with the curve of the glacier, which is of course entirely dependent on their opposition to its descent ; softened, however, into unity by the snow, which rarely melts on this high glacier surface.

The line *d c* is some mile and a half or two miles long ; it is part of the flank of the chain of the Dent d'Oche above the lake of Geneva, one or two of the lines of the higher and more distant ranges being given in combination with it.

h is a line about four feet long, a branch of spruce fir. I have taken this tree because it is commonly supposed to be stiff and ungraceful ; its outer sprays are, however, more noble in their sweep than almost any that I know : but this fragment is seen at great disadvantage, because placed upside down, in order that the reader may compare its curvatures with *c d*, *e g*, and *i k*, which are all mountain lines ; *e g*, about five hundred feet of the southern edge of the Matterhorn ; *i k*, the entire slope of the Aiguille Bouchard, from its summit into the valley of Chamouni, a line some three miles long ; *l m* is the line of the side of a willow leaf traced by laying the leaf on the paper ; *n o*, one of the innumerable groups of curves at the lip of a paper Nautilus ; *p*, a spiral, traced on the paper round a Serpula ; *q r*, the leaf of the Alisma Plantago with its interior ribs, real size ; *s t*, the side of a bay-leaf ; *u v*, of a salvia leaf : and it is to be carefully noted that these last curves, being never intended by nature to be seen singly, are more heavy



PLATE VII.—ABSTRACT LINES.

and less agreeable than any of the others which would be seen as independent lines. But all agree in their character of changeful curvature, the mountain and glacier lines only excelling the rest in delicacy and richness of transition.

§ xx. Why lines of this kind are beautiful, I endeavored to show in the "Modern Painters;" but one point, there omitted, may be mentioned here,—that almost all these lines are expressive of action of *force* of some kind, while the circle is a line of limitation or support. In leafage they mark the forces of its growth and expansion, but some among the most beautiful of them are described by bodies variously in motion, or subjected to force; as by projectiles in the air, by the particles of water in a gentle current, by planets in motion in an orbit, by their satellites, if the actual path of the satellite in space be considered instead of its relation to the planet; by boats, or birds, turning in the water or air, by clouds in various action upon the wind, by sails in the curvatures they assume under its force, and by thousands of other objects moving or bearing force. In the *Alisma* leaf, *q r*, the lines through its body, which are of peculiar beauty, mark the different expansions of its fibres, and are, I think, exactly the same as those which would be traced by the currents of a river entering a lake of the shape of the leaf, at the end where the stalk is, and passing out at its point. Circular curves, on the contrary, are always, I think, curves of limitation or support; that is to say, curves of perfect rest. The cylindrical curve round the stem of a plant binds its fibres together; while the *ascent* of the stem is in lines of various curvature: so the curve of the horizon and of the apparent heaven, of the rainbow, etc.: and though the reader might imagine that the circular orbit of any moving body, or the curve described by a sling, was a curve of motion, he should observe that the circular character is given to the curve not by the motion, but by the confinement: the circle is the consequence not of the energy of the body, but of its being forbidden to leave the centre; and whenever the whirling or circular motion can be fully impressed on it we obtain instant balance and rest with respect to the centre of the circle.

Hence the peculiar fitness of the circular curve as a sign of rest, and security of support, in arches ; while the other curves, belonging especially to action, are to be used in the more active architectural features—the hand and foot (the capital and base), and in all minor ornaments ; more freely in proportion to their independence of structural conditions.

§ XXI. We need not, however, hope to be able to imitate, in general work, any of the subtly combined curvatures of nature's highest designing : on the contrary, their extreme refinement renders them unfit for coarse service or material. Lines which are lovely in the pearly film of the Nautilus shell, are lost in the grey roughness of stone ; and those which are sublime in the blue of far away hills, are weak in the substance of incumbent marble. Of all the graceful lines assembled on Plate VII., we shall do well to be content with two of the simplest. We shall take one mountain line (*e g*) and one leaf line (*u w*), or rather fragments of them, for we shall perhaps not want them all. I will mark off from *u w* the little bit *x y*, and from *e g* the piece *e f* ; both which appear to me likely to be serviceable : and if hereafter we need the help of any abstract lines, we will see what we can do with these only.

§ XXII. 2. Forms of Earth (Crystals). It may be asked why I do not say rocks or mountains ? Simply, because the nobility of these depends, first, on their scale, and, secondly, on accident. Their scale cannot be represented, nor their accident systematised. No sculptor can in the least imitate the peculiar character of accidental fracture : he can obey or exhibit the laws of nature, but he cannot copy the felicity of her fancies, nor follow the steps of her fury. The very glory of a mountain is in the revolutions which raised it into power, and the forces which are striking it into ruin. But we want no cold and careful imitation of catastrophe ; no calculated mockery of convulsion ; no delicate recommendation of ruin. We are to follow the labor of Nature, but not her disturbance ; to imitate what she has deliberately ordained,* not

* Thus above, I adduced for the architect's imitation the appointed stories and beds of the Matterhorn, not its irregular forms of crag or fissure.

what she has violently suffered, or strangely permitted. The only uses, therefore, of rock form which are wise in the architect, are its actual introduction (by leaving untouched such blocks as are meant for rough service), and that noble use of the general examples of mountain structure of which I have often heretofore spoken. Imitations of rock form have, for the most part, been confined to periods of degraded feeling and to architectural toys or pieces of dramatic effect,—the Calvaries and holy sepulchres of Romanism, or the grottoes and fountains of English gardens. They were, however, not unfrequent in mediæval bas-reliefs; very curiously and elaborately treated by Ghiberti on the doors of Florence, and in religious sculpture necessarily introduced wherever the life of the anchorite was to be expressed. They were rarely introduced as of ornamental character, but for particular service and expression; we shall see an interesting example in the Ducal Palace at Venice.

§ xxiii. But against crystalline form, which is the completely systematised natural structure of the earth, none of these objections hold good, and, accordingly, it is an endless element of decoration, where higher conditions of structure cannot be represented. The four-sided pyramid, perhaps the most frequent of all natural crystals, is called in architecture a dogtooth; its use is quite limitless, and always beautiful: the cube and rhomb are almost equally frequent in chequers and dentils; and all mouldings of the middle Gothic are little more than representations of the canaliculated crystals of the beryl, and such other minerals:

§ xxiv. Not knowingly. I do not suppose a single hint was ever actually taken from mineral form; not even by the Arabs in their stalactite pendants and vaults: all that I mean to allege is, that beautiful ornament, wherever found, or however invented, is always either an intentional or unintentional copy of some constant natural form; and that in this particular instance, the pleasure we have in these geometrical figures of our own invention, is dependent for all its acuteness on the natural tendency impressed on us by our Creator to love the forms into which the earth He gave us to tread, and out of

which He formed our bodies, knit itself as it was separated from the deep.

§ xxv. 3. Forms of Water (Waves).

The reasons which prevent rocks from being used for ornament repress still more forcibly the portraiture of the sea. Yet the constant necessity of introducing some representation of water in order to explain the scene of events, or as a sacred symbol, has forced the sculptors of all ages to the invention of some type or letter for it, if not an actual imitation. We find every degree of conventionalism or of naturalism in these types, the earlier being, for the most part, thoughtful symbols; the latter, awkward attempts at portraiture.* The most conventional of all types is the Egyptian zigzag, preserved in the astronomical sign of Aquarius; but every nation, with any capacities of thought, has given, in some of its work, the same great definition of open water, as "an undulatory thing with fish in it." I say *open* water, because inland nations have a totally different conception of the element. Imagine for an instant the different feelings of an husbandman whose hut is built by the Rhine or the Po, and who sees, day by day, the same giddy succession of silent power, the same opaque, thick, whirling, irresistible labyrinth of rushing lines and twisted eddies, coiling themselves into serpentine race by the reedy banks, in omne volubilis ævum,—and the image of the sea in the mind of the fisher upon the rocks of Ithaca, or by the Straits of Sicily, who sees how, day by day, the morning winds come coursing to the shore, every breath of them with a green wave rearing before it; clear, crisp, ringing, merry-minded waves, that fall over and over each other, laughing like children as they near the beach, and at last clash themselves all into dust of crystal over the dazzling sweeps of sand. Fancy the difference of the image of water in those two minds, and then compare the sculpture of the coiling eddies of the Tigris and its reedy branches in those slabs of Nineveh, with the crested curls of the Greek sea on the coins of Camerina or Tarentum. But both agree in the undulatory lines, either of the currents or the surface,

* Appendix 21, "Ancient Representations of Water."

and in the introduction of fish as explanatory of the meaning of those lines (so also the Egyptians in their frescoes, with most elaborate realisation of the fish). There is a very curious instance on a Greek mirror in the British Museum, representing Orion on the Sea; and multitudes of examples with dolphins on the Greek vases: the type is preserved without alteration in mediæval painting and sculpture. The sea in that Greek mirror (at least 400 B.C.), in the mosaics of Torcello and St. Mark's, on the front of St. Frediano at Lucca, on the gate of the fortress of St. Michael's Mount in Normandy, on the Bayeux tapestry, and on the capitals of the Ducal Palace at Venice (under Arion on his Dolphin), is represented in a manner absolutely identical. Giotto, in the frescoes of Avignon, has, with his usual strong feeling for naturalism, given the best example I remember, in painting, of the unity of the conventional system with direct imitation, and that both in sea and river; giving in pure blue color the coiling whirlpool of the stream, and the curled crest of the breaker. But in all early sculptural examples, both imitation and decorative effect are subordinate to easily understood symbolical language; the undulatory lines are often valuable as an enrichment of surface, but are rarely of any studied gracefulness. One of the best examples I know of their expressive arrangement is around some figures in a spandril at Bourges, representing figures sinking in deep sea (the deluge): the waved lines yield beneath the bodies and wildly lave the edge of the moulding, two birds, as if to mark the reverse of all order of nature, lowest of all sunk in the depth of them. In later times of debasement, water began to be represented with its waves, foam, etc., as on the Vendramin tomb at Venice, above cited; but even there, without any definite ornamental purpose, the sculptor meant partly to explain a story, partly to display dexterity of chiselling, but not to produce beautiful forms pleasant to the eye. The imitation is vapid and joyless, and it has often been matter of surprise to me that sculptors, so fond of exhibiting their skill, should have suffered this imitation to fall so short, and remain so cold,—should not have taken more pains to curl the waves clearly, to

edge them sharply, and to express, by drillholes or other artifices, the character of foam. I think in one of the Antwerp churches something of this kind is done in wood, but in general it is rare.

§ xxvi. 4. Forms of Fire (Flames and Rays). If neither the sea nor the rock can be imagined, still less the devouring fire. It has been symbolised by radiation both in painting and sculpture, for the most part in the latter very unsuccessfully. It was suggested to me, not long ago,* that zigzag decorations of Norman architects were typical of light springing from the half-set orb of the sun; the resemblance to the ordinary sun type is indeed remarkable, but I believe accidental. I shall give you, in my large plates, two curious instances of radiation in brick ornament above arches, but I think these also without any very luminous intention. The imitations of fire in the torches of Cupids and genii, and burning in tops of urns, which attest and represent the mephitic inspirations of the seventeenth century in most London churches, and in monuments all over civilised Europe, together with the gilded rays of Romanist altars, may be left to such mercy as the reader is inclined to show them.

§ xxvii. 5. Forms of Air (Clouds). Hardly more manageable than flames, and of no ornamental use, their majesty being in scale and color, and inimitable in marble. They are lightly traced in much of the cinque cento sculpture; very boldly and grandly in the strange Last Judgment in the porch of St. Maclou at Rouen, described in the "Seven Lamps." But the most elaborate imitations are altogether of recent date, arranged in concretions like flattened sacks, forty or fifty feet above the altars of continental churches, mixed with the gilded truncheons intended for sunbeams above alluded to.

§ xxviii. 6. Shells. I place these lowest in the scale (after inorganic forms) as being moulds or coats of organism; not themselves organic. The sense of this, and of their being mere emptiness and deserted houses, must always prevent them, however beautiful in their lines, from being largely used in ornamentation. It is better to take the line and leave the

* By the friend to whom I owe Appendix 21.

shell. One form, indeed, that of the cockle, has been in all ages used as the decoration of half domes, which were named conchas from their shell form : and I believe the wrinkled lip of the cockle, so used, to have been the origin, in some parts of Europe at least, of the exuberant foliation of the round arch. The scallop also is a pretty radiant form, and mingles well with other symbols when it is needed. The crab is always as delightful as a grotesque, for here we suppose the beast inside the shell ; and he sustains his part in a lively manner among the other signs of the zodiac, with the scorpion ; or scattered upon sculptured shores, as beside the Bronze Boar of Florence. We shall find him in a basket at Venice, at the base of one of the Piazzetta shafts.

§ xxx. 7. Fish. These, as beautiful in their forms as they are familiar to our sight, while their interest is increased by their symbolic meaning, are of great value as material of ornament. Love of the picturesque has generally induced a choice of some supple form with scaly body and lashing tail, but the simplest fish form is largely employed in mediæval work. We shall find the plain oval body and sharp head of the Thunny constantly at Venice ; and the fish used in the expression of sea-water, or water generally, are always plain bodied creatures in the best mediæval sculpture. The Greek type of the dolphin, however, sometimes but slightly exaggerated from the real outline of the *Delphinus Delphis*,* is one of the most picturesque of animal forms ; and the action of its slow revolving plunge is admirably caught upon the surface sea represented in Greek vases.

§ xxx. 8. Reptiles and Insects. The forms of the serpent and lizard exhibit almost every element of beauty and horror in strange combination ; the horror, which in an imitation is felt only as a pleasurable excitement, has rendered them favorite subjects in all periods of art ; and the unity of both lizard

* One is glad to hear from Cuvier, that though dolphins in general are “ les plus carnassiers, et proportion gardée avec leur taille, les plus cruels de l'ordre ; ” yet that in the *Delphinus Delphis*, “ tout l'organisation de son cerveau annonce qu'il ne doit pas être dépourvu de la docilité qu'ils (les anciens) lui attribuaient.”

and serpent in the ideal dragon, the most picturesque and powerful of all animal forms, and of peculiar symbolical interest to the Christian mind, is perhaps the principal of all the materials of mediæval picturesque sculpture. By the best sculptors it is always used with this symbolic meaning, by the cinque cento sculptors as an ornament merely. The best and most natural representations of mere viper or snake are to be found interlaced among their confused groups of meaningless objects. The real power and horror of the snake-head has, however, been rarely reached. I shall give one example from Verona of the twelfth century.

Other less powerful reptile forms are not unfrequent. Small frogs, lizards, and snails almost always enliven the foregrounds and leafage of good sculpture. The tortoise is less usually employed in groups. Beetles are chiefly mystic and colossal. Various insects, like everything else in the world, occur in cinque cento work; grasshoppers most frequently. We shall see on the Ducal Palace at Venice an interesting use of the bee.

§ xxxi. 9. Branches and stems of Trees. I arrange these under a separate head; because, while the forms of leafage belong to all architecture, and ought to be employed in it always, those of the branch and stem belong to a peculiar imitative and luxuriant architecture, and are only applicable at times. Pagan sculptors seem to have perceived little beauty in the stems of trees; they were little else than timber to them; and they preferred the rigid and monstrous triglyph, or the fluted column, to a broken bough or gnarled trunk. But with Christian knowledge came a peculiar regard for the forms of vegetation, from the root upwards. The actual representation of the entire trees required in many scripture subjects,—as in the most frequent of Old Testament subjects, the Fall; and again in the Drunkenness of Noah, the Garden Agony, and many others, familiarised the sculptors of bas-relief to the beauty of forms before unknown; while the symbolical name given to Christ by the Prophets, “the Branch,” and the frequent expressions referring to this image throughout every scriptural description of conversion, gave an especial

interest to the Christian mind to this portion of vegetative structure. For some time, nevertheless, the sculpture of trees was confined to bas-relief; but it at last affected even the treatment of the main shafts in Lombard Gothic buildings,—as in the western façade of Genoa, where two of the shafts are represented as gnarled trunks: and as bas-relief itself became more boldly introduced, so did tree sculpture, until we find the writhed and knotted stems of the vine and fig used for angle shafts on the Doge's Palace, and entire oaks and apple-trees forming, roots and all, the principal decorative sculptures of the Scala tombs at Verona. It was then discovered to be more easy to carve branches than leaves; and, much helped by the frequent employment in later Gothic of the "Tree of Jesse," for traceries and other purposes, the system reached full development in a perfect thicket of twigs, which form the richest portion of the decoration of the porches of Beauvais. It had now been carried to its richest extreme: men wearied of it and abandoned it, and like all other natural and beautiful things, it was ostracised by the mob of Renaissance architects. But it is interesting to observe how the human mind, in its acceptance of this feature of ornament, proceeded from the ground, and followed, as it were, the natural growth of the tree. It began with the rude and solid trunk, as at Genoa; then the branches shot out, and became loaded leaves; autumn came, the leaves were shed, and the eye was directed to the extremities of the delicate branches;—the Renaissance frosts came, and all perished.

§ xxxii. 10. Foliage, Flowers, and Fruit. It is necessary to consider these as separated from the stems; not only, as above noted, because their separate use marks another school of architecture, but because they are the only organic structures which are capable of being so treated, and intended to be so, without strong effort of imagination. To pull animals to pieces, and use their paws for feet of furniture, or their heads for terminations of rods and shafts, is *usually* the characteristic of feelingless schools; the greatest men like their animals whole. The head may, indeed, be so managed as to look emergent from the stone, rather than fastened to it; and

wherever there is throughout the architecture any expression of sternness or severity (severity in its literal sense, as in Romans, xi. 22), such divisions of the living form may be permitted ; still, you cannot cut an animal to pieces as you can gather a flower or a leaf. These were intended for our gathering, and for our constant delight : wherever men exist in a perfectly civilised and healthy state, they have vegetation around them ; wherever their state approaches that of innocence or perfectness, it approaches that of Paradise,—it is a dressing of garden. And, therefore, where nothing else can be used for ornament, vegetation may ; vegetation in any form, however fragmentary, however abstracted. A single leaf laid upon the angle of a stone, or the mere form or framework of the leaf drawn upon it, or the mere shadow and ghost of the leaf,—the hollow “foil” cut out of it,—possesses a charm which nothing else can replace ; a charm not exciting, nor demanding laborious thought or sympathy, but perfectly simple, peaceful, and satisfying.

§ xxxiii. The full recognition of leaf forms, as the general source of subordinate decoration, is one of the chief characteristics of Christian architecture ; but the two *roots* of leaf ornament are the Greek acanthus, and the Egyptian lotus.*

The dry land and the river thus each contributed their part ; and all the florid capitals of the richest Northern Gothic on the one hand, and the arrowy lines of the severe Lombardic capitals on the other, are founded on these two gifts of the dust of Greece and the waves of the Nile. The leaf which is, I believe, called the Persepolitan water-leaf, is to be associated with the lotus flower and stem, as the origin of our noblest types of simple capital ; and it is to be noted that the florid leaves of the dry land are used most by the Northern archi-

* Vide Wilkinson, vol. v., woodcut No. 478, fig. 8. The tamarisk appears afterwards to have given the idea of a subdivision of leaf more pure and quaint than that of the acanthus. Of late our botanists have discovered, in the “Victoria regia” (supposing its blossom reversed), another strangely beautiful type of what we may perhaps hereafter find it convenient to call *Lily* capitals.

fects, while the water leaves are gathered for their ornaments by the parched builders of the Desert.

§ xxxiv. Fruit is, for the most part, more valuable in color than form ; nothing is more beautiful as a subject of sculpture on a tree ; but, gathered and put in baskets, it is quite possible to have too much of it. We shall find it so used very dexterously on the Ducal Palace of Venice, there with a meaning which rendered it right necessary ; but the Renaissance architects address themselves to spectators who care for nothing but feasting, and suppose that clusters of pears and pineapples are visions of which their imagination can never weary, and above which it will never care to rise. I am no advocate for imageworship, as I believe the reader will elsewhere sufficiently find ; but I am very sure that the Protestantism of London would have found itself quite as secure in a cathedral decorated with statues of good men, as in one hung round with bunches of ribston pippins.

§ xxxv. 11. Birds. The perfect and simple grace of bird form, in general, has rendered it a favorite subject with early sculptors, and with those schools which loved form more than action ; but the difficulty of expressing action, where the muscular markings are concealed, has limited the use of it in later art. Half the ornament, at least, in Byzantine architecture, and a third of that of Lombardic, is composed of birds, either pecking at fruit or flowers, or standing on either side of a flower or vase, or alone, as generally the symbolical peacock. But how much of our general sense of grace or power of motion, of serenity, peacefulness, and spirituality, we owe to these creatures, it is impossible to conceive ; their wings supplying us with almost the only means of representation of spiritual motion which we possess, and with an ornamental form of which the eye is never weary, however meaninglessly or endlessly repeated ; whether in utter isolation, or associated with the bodies of the lizard, the horse, the lion, or the man. The heads of the birds of prey are always beautiful, and used as the richest ornaments in all ages.

§ xxxvi. 12. Quadrupeds and Men. Of quadrupeds the horse has received an elevation into the primal rank of sculp-

tural subject, owing to his association with men. The full value of other quadruped forms has hardly been perceived, or worked for, in late sculpture ; and the want of science is more felt in these subjects than in any other branches of early work. The greatest richness of quadruped ornament is found in the hunting sculpture of the Lombards ; but rudely treated (the most noble examples of treatment being the lions of Egypt, the Ninevite bulls, and the mediæval griffins). Quadrupeds of course form the noblest subjects of ornament next to the human form ; this latter, the chief subject of sculpture, being sometimes the end of architecture rather than its decoration.

We have thus completed the list of the materials of architectural decoration, and the reader may be assured that no effort has ever been successful to draw elements of beauty from any other sources than these. Such an effort was once resolutely made. It was contrary to the religion of the Arab to introduce any animal form into his ornament ; but although all the radiance of color, all the refinements of proportion, and all the intricacies of geometrical design were open to him, he could not produce any noble work without an *abstraction* of the forms of leafage, to be used in his capitals, and made the ground plan of his chased ornament. But I have above noted that coloring is an entirely distinct and independent art ; and in the "Seven Lamps" we saw that this art had most power when practised in arrangements of simple geometrical form : the Arab, therefore, lay under no disadvantage in coloring. and he had all the noble elements of constructive and proportional beauty at his command : he might not imitate the seashell, but he could build the dome. The imitation of radiance by the variegated voussoir, the expression of the sweep of the desert by the barred red lines upon the wall, the starred in-shedding of light through his vaulted roof, and all the endless fantasy of abstract line,* were still in the power of his ardent and fantastic spirit. Much he achieved ; and yet in the effort of his overtaxed invention, restrained from its proper food, he made his architecture a glittering vacillation of undisciplined

* Appendix 22, "Arabian Ornamentation."

enchantment, and left the lustre of its edifices to wither like a startling dream, whose beauty we may indeed feel, and whose instruction we may receive, but must smile at its inconsistency, and mourn over its evanescence.

CHAPTER XXI.

TREATMENT OF ORNAMENT.

§ I. WE now know where we are to look for subjects of decoration. The next question is, as the reader must remember, how to treat or express these subjects.

There are evidently two branches of treatment: the first being the expression, or rendering to the eye and mind, of the thing itself; and the second, the arrangement of the thing so expressed: both of these being quite distinct from the placing of the ornament in proper parts of the building. For instance, suppose we take a vine-leaf for our subject. The first question is, how to cut the vine-leaf? Shall we cut its ribs and notches on the edge, or only its general outline? and so on. Then, how to arrange the vine-leaves when we have them; whether symmetrically, or at random; or unsymmetrically, yet within certain limits? All these I call questions of treatment. Then, whether the vine-leaves so arranged are to be set on the capital of a pillar or on its shaft, I call a question of place.

§ II. So, then, the questions of mere treatment are twofold, how to express, and how to arrange. And expression is to the mind or the sight. Therefore, the inquiry becomes really threefold:—

1. How ornament is to be expressed with reference to the mind.
2. How ornament is to be arranged with reference to the sight.
3. How ornament is to be arranged with reference to both.

§ III. (1.) How is ornament to be treated with reference to the mind?

If, to produce a good or beautiful ornament, it were only necessary to produce a perfect piece of sculpture, and if a well cut group of flowers or animals were indeed an ornament wherever it might be placed, the work of the architect would be comparatively easy. Sculpture and architecture would become separate arts; and the architect would order so many pieces of such subject and size as he needed, without troubling himself with any questions but those of disposition and proportion. But this is not so. *No perfect piece either of painting or sculpture is an architectural ornament at all*, except in that vague sense in which any beautiful thing is said to ornament the place it is in. Thus we say that pictures ornament a room; but we should not thank an architect who told us that his design, to be complete, required a Titian to be put in one corner of it, and a Velasquez in the other; and it is just as unreasonable to call perfect sculpture, niched in, or encrusted on a building, a portion of the ornament of that building, as it would be to hang pictures by the way of ornament on the outside of it. It is very possible that the sculptured work may be harmoniously associated with the building, or the building executed with reference to it; but in this latter case the architecture is subordinate to the sculpture, as in the Medicean chapel, and I believe also in the Parthenon. And so far from the perfection of the work conducing to its ornamental purpose, we may say, with entire security, that its perfection, in some degree, unfits it for its purpose, and that no absolutely complete sculpture can be decoratively right. We have a familiar instance in the flower-work of St. Paul's, which is probably, in the abstract, as perfect flower sculpture as could be produced at the time; and which is just as rational an ornament of the building as so many valuable Van Huysums, framed and glazed and hung up over each window.

§ IV. The especial condition of true ornament is, that it be beautiful in its place, and nowhere else, and that it aid the effect of every portion of the building over which it has influence; that it does not, by its richness, make other parts bald,

or, by its delicacy, make other parts coarse. Every one of its qualities has reference to its place and use: *and it is fitted for its service by what would be faults and deficiencies if it had no especial duty.* Ornament, the servant, is often formal, where sculpture, the master, would have been free; the servant is often silent where the master would have been eloquent; or hurried, where the master would have been serene.

§ v. How far this subordination is in different situations to be expressed, or how far it may be surrendered, and ornament, the servant, be permitted to have independent will; and by what means the subordination is best to be expressed when it is required, are by far the most difficult questions I have ever tried to work out respecting any branch of art; for, in many of the examples to which I look as authoritative in their majesty of effect, it is almost impossible to say whether the abstraction or imperfection of the sculpture was owing to the choice, or the incapacity of the workman; and if to the latter, how far the result of fortunate incapacity can be imitated by prudent self-restraint. The reader, I think, will understand this at once by considering the effect of the illuminations of an old missal. In their bold rejection of all principles of perspective, light and shade, and drawing, they are infinitely more ornamental to the page, owing to the vivid opposition of their bright colors and quaint lines, than if they had been drawn by Da Vinci himself: and so the Arena chapel is far more brightly *decorated* by the archaic frescoes of Giotto, than the Stanze of the Vatican are by those of Raffaello. But how far it is possible to recur to such archaicism, or to make up for it by any voluntary abandonment of power, I cannot as yet venture in any wise to determine.

§ vi. So, on the other hand, in many instances of finished work in which I find most to regret or to reprobate, I can hardly distinguish what is erroneous in principle from what is vulgar in execution. For instance, in most Romanesque churches of Italy, the porches are guarded by gigantic animals, lions or griffins, of admirable severity of design; yet, in many cases, of so rude workmanship, that it can hardly be determined how much of this severity was intentional,—how much

involuntary : in the cathedral of Genoa two modern lions have, in imitation of this ancient custom, been placed on the steps of its west front ; and the Italian sculptor, thinking himself a marvellous great man because he knew what lions were really like, has copied them, in the menagerie, with great success, and produced two hairy and well-whiskered beasts, as like to real lions as he could possibly cut them. One wishes them back in the menagerie for his pains ; but it is impossible to say how far the offence of their presence is owing to the mere stupidity and vulgarity of the sculptor, and how far we might have been delighted with a realisation, carried to nearly the same length by Ghiberti or Michael Angelo. (I say *nearly*, because neither Ghiberti nor Michael Angelo would ever have attempted, or permitted, entire realisation, even in independent sculpture.

§ VII. In spite of these embarrassments, however, some few certainties may be marked in the treatment of past architecture, and secure conclusions deduced for future practice. There is first, for instance, the assuredly intended and resolute abstraction of the Ninevite and Egyptian sculptors. The men who cut those granite lions in the Egyptian room of the British Museum, and who carved the calm faces of those Ninevite kings, knew much more, both of lions and kings, than they chose to express. Then there is the Greek system, in which the human sculpture is perfect, the architecture and animal sculpture is subordinate to it, and the architectural ornament severely subordinated to this again, so as to be composed of little more than abstract lines : and, finally, there is the peculiarly mediæval system, in which the inferior details are carried to as great or greater imitative perfection as the higher sculpture ; and the subordination is chiefly effected by symmetries of arrangement, and quaintnesses of treatment, respecting which it is difficult to say how far they resulted from intention, and how far from incapacity.

§ VIII. Now of these systems, the Ninevite and Egyptian are altogether opposed to modern habits of thought and action ; they are sculptures evidently executed under absolute authorities, physical and mental, such as cannot at present ex-

ist. The Greek system presupposes the possession of a Phidias; it is ridiculous to talk of building in the Greek manner; you may build a Greek shell or box, such as the Greek intended to contain sculpture, but you have not the sculpture to put in it. Find your Phidias first, and your new Phidias will very soon settle all your architectural difficulties in very unexpected ways indeed; but until you find him, do not think yourselves architects while you go on copying those poor subordinations, and secondary and tertiary orders of ornament, which the Greek put on the shell of his sculpture. Some of them, beads, and dentils, and such like, are as good as they can be for their work, and you may use them for subordinate work still; but they are nothing to be proud of, especially when you did not invent them: and others of them are mistakes and impertinences in the Greek himself, such as his so-called honeysuckle ornaments and others, in which there is a starched and dull suggestion of vegetable form, and yet no real resemblance nor life, for the conditions of them result from his own conceit of himself, and ignorance of the physical sciences, and want of relish for common nature, and vain fancy that he could improve everything he touched, and that he honored it by taking it into his service: by freedom from which conceits the true Christian architecture is distinguished—not by points to its arches.

§ ix. There remains, therefore, only the mediæval system, in which I think, generally, more completion is permitted (though this often because more was possible) in the inferior than in the higher portions of ornamental subject. Leaves, and birds, and lizards are realised, or nearly so; men and quadrupeds formalised. For observe, the smaller and inferior subject remains subordinate, however richly finished; but the human sculpture can only be subordinate by being imperfect. The realisation is, however, in all cases, dangerous except under most skilful management, and the abstraction, if true and noble, is almost always more delightful.*

§ x. What, then, is noble abstraction? It is taking first

* Vide "Seven Lamps," Chap. IV. § 34.

the essential elements of the thing to be represented, then the rest in the order of importance (so that wherever we pause we shall always have obtained more than we leave behind), and using any expedient to impress what we want upon the mind, without caring about the mere literal accuracy of such expedient. Suppose, for instance, we have to represent a peacock: now a peacock has a graceful neck, so has a swan; it has a high crest, so has a cockatoo; it has a long tail, so has a bird of Paradise. But the whole spirit and power of peacock is in those eyes of the tail. It is true, the argus pheasant, and one or two more birds, have something like them, but nothing for a moment comparable to them in brilliancy: express the gleaming of the blue eyes through the plumage, and you have nearly all you want of peacock, but without this, nothing; and yet those eyes are not in relief; a rigidly *true* sculpture of a peacock's form could have no eyes,—nothing but feathers. Here, then, enters the stratagem of sculpture; you *must* cut the eyes in relief, somehow or another; see how it is done in the peacock on the opposite page; it is so done by nearly all the Byzantine sculptors: this particular peacock is meant to be seen at some distance (how far off I know not, for it is an interpolation in the building where it occurs, of which more hereafter), but at all events at a distance of thirty or forty feet; I have put it close to you that you may see plainly the rude rings and rods which stand for the eyes and quills, but at the just distance their effect is perfect.

§ XI. And the simplicity of the means here employed may help us, both to some clear understanding of the spirit of Ninevite and Egyptian work, and to some perception of the kind of enfantillage or archaicism to which it may be possible, even in days of advanced science, legitimately to return. The architect has no right, as we said before, to require of us a picture of Titian's in order to complete his design; neither has he the right to calculate on the co-operation of perfect sculptors, in subordinate capacities. Far from this; his business is to dispense with such aid altogether, and to devise such a system of ornament as shall be capable of execution by uninventive and even unintelligent workmen; for



I. Ruskin

T.S. Boys

Decoration by Disks.

PALAZZO DEI BADOARI PARTECIPAZZI.

supposing that he required noble sculpture for his ornament, how far would this at once limit the number and the scale of possible buildings? Architecture is the work of nations; but we cannot have nations of great sculptors. Every house in every street of every city ought to be good architecture, but we cannot have Flaxman or Thorwaldsen at work upon it: nor, even if we chose only to devote ourselves to our public buildings, could the mass and majesty of them be great, if we required all to be executed by great men; greatness is not to be had in the required quantity. Giotto may design a campanile, but he cannot carve it; he can only carve one or two of the bas-reliefs at the base of it. And with every increase of your fastidiousness in the execution of your ornament, you diminish the possible number and grandeur of your buildings. Do not think you can educate your workmen, or that the demand for perfection will increase the supply: educated imbecility and finessed foolishness are the worst of all imbecilities and foolishnesses; and there is no free-trade measure, which will ever lower the price of brains,—there is no California of common sense. Exactly in the degree in which you require your decoration to be wrought by thoughtful men, you diminish the extent and number of architectural works. Your business as an architect, is to calculate only on the co-operation of inferior men, to think for them, and to indicate for them such expressions of your thoughts as the weakest capacity can comprehend and the feeblest hand can execute. This is the definition of the purest architectural abstractions. They are the deep and laborious thoughts of the greatest men, put into such easy letters that they can be written by the simplest. *They are expressions of the mind of manhood by the hands of childhood.*

§ XII. And now suppose one of those old Ninevite or Egyptian builders, with a couple of thousand men—mud-bred, onion-eating creatures—under him, to be set to work, like so many ants, on his temple sculptures. What is he to do with them? He can put them through a granitic exercise of current hand; he can teach them all how to curl hair thoroughly into croche-cœurs, as you teach a bench of school-boys

how to shape pothooks ; he can teach them all how to draw long eyes and straight noses, and how to copy accurately certain well-defined lines. Then he fits his own great design to their capacities ; he takes out of king, or lion, or god, as much as was expressible by croche-cœurs and granitic pothooks ; he throws this into noble forms of his own imagining, and having mapped out their lines so that there can be no possibility of error, sets his two thousand men to work upon them, with a will, and so many onions a day.

§ XIII. I said those times cannot now return. We have, with Christianity, recognised the individual value of every soul ; and there is no intelligence so feeble but that its single ray may in some sort contribute to the general light. This is the glory of Gothic architecture, that every jot and tittle, every point and niche of it, affords room, fuel, and focus for individual fire. But you cease to acknowledge this, and you refuse to accept the help of the lesser mind, if you require the work to be all executed in a great manner. Your business is to think out all of it nobly, to dictate the expression of it as far as your dictation can assist the less elevated intelligence : then to leave this, aided and taught as far as may be, to its own simple act and effort ; and to rejoice in its simplicity if not in its power, and in its vitality if not in its science.

§ XIV. We have, then, three orders of ornament, classed according to the degrees of correspondence of the executive and conceptive minds. We have the servile ornament, in which the executive is absolutely subjected to the inventive, —the ornament of the great Eastern nations, more especially Hamite, and all pre-Christian, yet thoroughly noble in its submissiveness. Then we have the mediæval system, in which the mind of the inferior workman is recognised, and has full room for action, but is guided and ennobled by the ruling mind. This is the truly Christian and only perfect system. Finally, we have ornaments expressing the endeavor to equalise the executive and inventive,—endeavor which is Renaissance and revolutionary, and destructive of all noble architecture.

§ xv. Thus far, then, of the incompleteness or simplicity of execution necessary in architectural ornament, as referred to the mind. Next we have to consider that which is required when it is referred to the sight, and the various modifications of treatment which are rendered necessary by the variation of its distance from the eye. I say necessary: not merely expedient or economical. It is foolish to carve what is to be seen forty feet off with the delicacy which the eye demands within two yards; not merely because such delicacy is lost in the distance, but because it is a great deal worse than lost:—the delicate work has actually worse effect in the distance than rough work. This is a fact well known to painters, and, for the most part, acknowledged by the critics of painters, namely, that there is a certain distance for which a picture is painted; and that the finish, which is delightful if that distance be small, is actually injurious if the distance be great: and, moreover, that there is a particular method of handling which none but consummate artists reach, which has its effects at the intended distance, and is altogether hieroglyphical and unintelligible at any other. This, I say, is acknowledged in painting, but it is not practically acknowledged in architecture; nor until my attention was especially directed to it, had I myself any idea of the care with which this great question was studied by the mediæval architects. On my first careful examination of the capitals of the upper arcade of the Ducal Palace at Venice, I was induced, by their singular inferiority of workmanship, to suppose them posterior to those of the lower arcade. It was not till I discovered that some of those which I thought the worst above, were the best when seen from below, that I obtained the key to this marvellous system of adaptation; a system which I afterwards found carried out in every building of the great times which I had opportunity of examining.

§ xvi. There are two distinct modes in which this adaptation is effected. In the first, the same designs which are delicately worked when near the eye, are rudely cut, and have far fewer details when they are removed from it. In this method

it is not always easy to distinguish economy from skill, or slovenliness from science. But, in the second method, a different design is adopted, composed of fewer parts and of simpler lines, and this is cut with exquisite precision. This is of course the higher method, and the more satisfactory proof of purpose; but an equal degree of imperfection is found in both kinds when they are seen close; in the first, a bald execution of a perfect design; the second, a baldness of design with perfect execution. And in these very imperfections lies the admirableness of the ornament.

§ XVII. It may be asked whether, in advocating this adaptation to the distance of the eye, I obey my adopted rule of observance of natural law. Are not all natural things, it may be asked, as lovely near as far away? Nay, not so. Look at the clouds, and watch the delicate sculpture of their alabaster sides, and the rounded lustre of their magnificent rolling. They are meant to be beheld far away; they were shaped for their place, high above your head; approach them, and they fuse into vague mists, or whirl away in fierce fragments of thunderous vapor. Look at the crest of the Alp, from the far-away plains over which its light is cast, whence human souls have communion with it by their myriads. The child looks up to it in the dawn, and the husbandman in the burden and heat of the day, and the old man in the going down of the sun, and it is to them all as the celestial city on the world's horizon; dyed with the depth of heaven, and clothed with the calm of eternity. There was it set, for holy dominion, by Him who marked for the sun his journey, and bade the moon know her going down. It was built for its place in the far-off sky; approach it, and as the sound of the voice of man dies away about its foundations, and the tide of human life shallowed upon the vast ærial shore, is at last met by the Eternal "Here shall thy waves be stayed," the glory of its aspect fades into blanched fearfulness; its purple walls are rent into grisly rocks, its silver fretwork saddened into wasting snow, the storm-brands of ages are on its breast, the ashes of its own ruin lie solemnly on its white raiment.

Nor in such instances as these alone, though strangely enough, the discrepancy between apparent and actual beauty is greater in proportion to the unapproachableness of the object, is the law observed. For every distance from the eye there is a peculiar kind of beauty, or a different system of lines of form; the sight of that beauty is reserved for that distance, and for that alone. If you approach nearer, that kind of beauty is lost, and another succeeds, to be disorganised and reduced to strange and incomprehensible means and appliances in its turn. If you desire to perceive the great harmonies of the form of a rocky mountain, you must not ascend upon its sides. All is there disorder and accident, or seems so; sudden starts of its shattered beds hither and thither; ugly struggles of unexpected strength from under the ground; fallen fragments, toppling one over another into more helpless fall. Retire from it, and, as your eye commands it more and more, as you see the ruined mountain world with a wider glance, behold! dim sympathies begin to busy themselves in the disjointed mass; line binds itself into stealthy fellowship with line; group by group, the helpless fragments gather themselves into ordered companies; new captains of hosts and masses of battalions become visible, one by one, and far away answers of foot to foot, and of bone to bone, until the powerless chaos is seen risen up with girded loins, and not one piece of all the unregarded heap could now be spared from the mystic whole.

§ XVIII. Now it is indeed true that where nature loses one kind of beauty, as you approach it, she substitutes another; this is worthy of her infinite power: and, as we shall see, art can sometimes follow her even in doing this; but all I insist upon at present is, that the several effects of nature are each worked with means referred to a particular distance, and producing their effect at that distance only. Take a singular and marked instance: When the sun rises behind a ridge of pines, and those pines are seen from a distance of a mile or two, against his light, the whole form of the tree, trunk, branches, and all, becomes one frostwork of intensely brilliant silver, which is relieved against the clear sky like a burning fringe,

for some distance on either side of the sun.* Now suppose that a person who had never seen pines were, for the first time in his life, to see them under this strange aspect, and, reasoning as to the means by which such effect could be produced, laboriously to approach the eastern ridge, how would he be amazed to find that the fiery spectres had been produced by trees with swarthy and grey trunks, and dark green leaves! We, in our simplicity, if we had been required to produce such an appearance, should have built up trees of chased silver, with trunks of glass, and then been grievously amazed to find that, at two miles off, neither silver nor glass were any more visible; but nature knew better, and prepared for her fairy work with the strong branches and dark leaves, in her own mysterious way.

§ XIX. Now this is exactly what you have to do with your good ornament. It may be that it is capable of being approached, as well as likely to be seen far away, and then it ought to have microscopic qualities, as the pine leaves have, which will bear approach. But your calculation of its purpose is for a glory to be produced at a given distance; it may be here, or may be there, but it is a *given* distance; and the excellence of the ornament depends upon its fitting that distance, and being seen better there than anywhere else, and having a particular function and form which it can only discharge and assume there. You are never to say that ornament has great merit because “you cannot see the beauty of it here;” but, it has great merit because “you *can* see its beauty *here only*.” And to give it this merit is just about as difficult a task as I could well set you. I have above noted the two

* Shakspeare and Wordsworth (I think they only) have noticed this, Shakspeare, in Richard II. :—

“ But when, from under this terrestrial ball,
He fires the proud tops of the eastern pines.”

And Wordsworth, in one of his minor poems, on leaving Italy :

“ My thoughts become bright like yon edging of pines
On the steep’s lofty verge—how it blackened the air!
But, touched from behind by the sun, it now shines
With threads that seem part of his own silver hair.”

ways in which it is done : the one, being merely rough cutting, may be passed over ; the other, which is scientific alteration of design, falls, itself, into two great branches, Simplification and Emphasis.

A word or two is necessary on each of these heads.

§ xx. When an ornamental work is intended to be seen near, if its composition be indeed fine, the subdued and delicate portions of the design lead to, and unite, the energetic parts, and those energetic parts form with the rest a whole, in which their own immediate relations to each other are not perceived. Remove this design to a distance, and the connecting delicacies vanish, the energies alone remain, now either disconnected altogether, or assuming with each other new relations, which, not having been intended by the designer, will probably be painful. There is a like, and a more palpable, effect, in the retirement of a band of music in which the instruments are of very unequal powers ; the fluting and fifeing expire, the drumming remains, and that in a painful arrangement, as demanding something which is unheard. In like manner, as the designer at arm's length removes or elevates his work, fine gradations, and roundings, and incidents, vanish, and a totally unexpected arrangement is established between the remainder of the markings, certainly confused, and in all probability painful.

§ xxi. The art of architectural design is therefore, first, the preparation for this beforehand, the rejection of all the delicate passages as worse than useless, and the fixing the thought upon the arrangement of the features which will remain visible far away. Nor does this always imply a diminution of resource ; for, while it may be assumed as a law that fine modulation of surface in light becomes quickly invisible as the object retires, there are a softness and mystery given to the harder markings, which enable them to be safely used as media of expression. There is an exquisite example of this use, in the head of the Adam of the Ducal Palace. It is only at the height of 17 or 18 feet above the eye ; nevertheless, the sculptor felt it was no use to trouble himself about drawing the corners of the mouth, or the lines of the lips, delicately, at that distance ; his object

has been to mark them clearly, and to prevent accidental shadows from concealing them, or altering their expression. The lips are cut thin and sharp, so that their line cannot be mistaken, and a good deep drill-hole struck into the angle of the mouth; the eye is anxious and questioning, and one is surprised, from below, to perceive a kind of darkness in the iris of it, neither like color, nor like a circular furrow. The expedient can only be discovered by ascending to the level of the head; it is one which would have been quite inadmissible except in distant work, six drill-holes cut into the iris, round a central one for the pupil.

§ XXII. By just calculation, like this, of the means at our disposal, by beautiful arrangement of the prominent features, and by choice of different subjects for different places, choosing the broadest forms for the farthest distance, it is possible to give the impression, not only of perfection, but of an exquisite delicacy, to the most distant ornament. And this is the true sign of the right having been done, and the utmost possible power attained:—The spectator should be satisfied to stay in his place, feeling the decoration, wherever it may be, equally rich, full, and lovely: not desiring to climb the steeples in order to examine it, but sure that he has it all, where he is. Perhaps the capitals of the cathedral of Genoa are the best instances of absolute perfection in this kind: seen from below, they appear as rich as the frosted silver of the Strada degli Orefici; and the nearer you approach them, the less delicate they seem.

§ XXIII. This is, however, not the only mode, though the best, in which ornament is adapted for distance. The other is emphasis,—the unnatural insisting upon explanatory lines, where the subject would otherwise become unintelligible. It is to be remembered that, by a deep and narrow incision, an architect has the power, at least in sunshine, of drawing a black line on stone, just as vigorously as it can be drawn with chalk on grey paper; and that he may thus, wherever and in the degree that he chooses, substitute *chalk sketching* for sculpture. They are curiously mingled by the Romans. The bas-reliefs of the Arc d'Orange are small, and would be con-

fused, though in bold relief, if they depended for intelligibility on the relief only ; but each figure is outlined by a strong *incision* at its edge into the background, and all the ornaments on the armor are simply drawn with incised lines, and not cut out at all. A similar use of lines is made by the Gothic nations in all their early sculpture, and with delicious effect. Now, to draw a mere pattern—as, for instance, the bearings of a shield—with these simple incisions, would, I suppose, occupy an able sculptor twenty minutes or half an hour ; and the pattern is then clearly seen, under all circumstances of light and shade ; there can be no mistake about it, and no missing it. To carve out the bearings in due and finished relief would occupy a long summer's day, and the results would be feeble and indecipherable in the best lights, and in some lights totally and hopelessly invisible, ignored, non-existent. Now the Renaissance architects, and our modern ones, despise the simple expedient of the rough Roman or barbarian. They do not care to be understood. They care only to speak finely, and be thought great orators, if one could only hear them. So I leave you to choose between the old men, who took minutes to tell things plainly, and the modern men, who take days to tell them unintelligibly.

§ xxiv. All expedients of this kind, both of simplification and energy, for the expression of details at a distance where their actual forms would have been invisible, but more especially this linear method, I shall call Proutism ; for the greatest master of the art in modern times has been Samuel Prout. He actually takes up buildings of the later times in which the ornament has been too refined for its place, and translates it into the energised linear ornament of earlier art : and to this power of taking the life and essence of decoration, and putting it into a perfectly intelligible form, when its own fulness would have been confused, is owing the especial power of his drawings. Nothing can be more closely analogous than the method with which an old Lombard uses his chisel, and that with which Prout uses the reed-pen ; and we shall see presently farther correspondence in their feeling about the enrichment of luminous surfaces.

§ xxv. Now, all that has been hitherto said refers to ornament whose distance is fixed, or nearly so; as when it is at any considerable height from the ground, supposing the spectator to desire to see it, and to get as near it as he can. But the distance of ornament is never fixed to the *general* spectator. The tower of a cathedral is bound to look well, ten miles off, or five miles, or half a mile, or within fifty yards. The ornaments of its top have fixed distances, compared with those of its base; but quite unfixed distances in their relation to the great world: and the ornaments of the base have no fixed distance at all. They are bound to look well from the other side of the cathedral close, and to look equally well, or better, as we enter the cathedral door. How are we to manage this?

§ xxvi. As nature manages it. I said above, § xvii., that for every distance from the eye there was a different system of form in all natural objects: this is to be so then in architecture. The lesser ornament is to be grafted on the greater, and third or fourth orders of ornaments upon this again, as need may be, until we reach the limits of possible sight; each order of ornament being adapted for a different distance: first, for example, the great masses,—the buttresses and stories and black windows and broad cornices of the tower, which give it make, and organism, as it rises over the horizon, half a score of miles away: then the traceries and shafts and pinnacles, which give it richness as we approach: then the niches and statues and knobs and flowers, which we can only see when we stand beneath it. At this third order of ornament, we may pause, in the upper portions; but on the roofs of the niches, and the robes of the statues, and the rolls of the mouldings, comes a fourth order of ornament, as delicate as the eye can follow, when any of these features may be approached.

§ xxvii. All good ornamentation is thus arborescent, as it were, one class of it branching out of another and sustained by it; and its nobility consists in this, that whatever order or class of it we may be contemplating, we shall find it subordinated to a greater, simpler, and more powerful; and if we then contemplate the greater order, we shall find it again subordinated to a greater still; until the greatest can only be

quite grasped by retiring to the limits of distance commanding it.

And if this subordination be not complete, the ornament is bad : if the figurings and chasings and borderings of a dress be not subordinated to the folds of it,—if the folds are not subordinate to the action and mass of the figure,—if this action and mass not to the divisions of the recesses and shafts among which it stands,—if these not to the shadows of the great arches and buttresses of the whole building, in each case there is error ; much more if all be contending with each other and striving for attention at the same time.

§ xxviii. It is nevertheless evident, that, however perfect this distribution, there cannot be orders adapted to *every* distance of the spectator. Between the ranks of ornament there must always be a bold separation ; and there must be many intermediate distances, where we are too far off to see the lesser rank clearly, and yet too near to grasp the next higher rank wholly : and at all these distances the spectator will feel himself ill-placed, and will desire to go nearer or farther away. This must be the case in all noble work, natural or artificial. It is exactly the same with respect to Rouen cathedral or the Mont Blanc. We like to see them from the other side of the Seine, or of the lake of Geneva ; from the Marché aux Fleurs, or the Valley of Chamouni ; from the parapets of the apse, or the crags of the Montagne de la Côte : but there are intermediate distances which dissatisfy us in either case, and from which one is in haste either to advance or to retire.

§ xxix. Directly opposed to this ordered, disciplined, well officered and variously ranked ornament, this type of divine, and therefore of all good human government, is the democratic ornament, in which all is equally influential, and has equal office and authority ; that is to say, none of it any office nor authority, but a life of continual struggle for independence and notoriety, or of gambling for chance regards. The English perpendicular work is by far the worst of this kind that I know ; its main idea, or decimal fraction of an idea, being to cover its walls with dull, successive, eternity of reticulation, to fill with equal foils the equal interstices between the equal

bars, and charge the interminable blanks with statues and rosettes, invisible at a distance, and uninteresting near.

The early Lombardic, Veronese, and Norman work is the exact reverse of this ; being divided first into large masses, and these masses covered with minute chasing and surface work, which fill them with interest, and yet do not disturb nor divide their greatness. The lights are kept broad and bright, and yet are found on near approach to be charged with intricate design. This, again, is a part of the great system of treatment which I shall hereafter call "Proutism ;" much of what is thought mannerism and imperfection in Prout's work, being the result of his determined resolution that minor details shall never break up his large masses of light.

§ xxx. Such are the main principles to be observed in the adaptation of ornament to the sight. We have lastly to inquire by what method, and in what quantities, the ornament, thus adapted to mental contemplation, and prepared for its physical position, may most wisely be arranged. I think the method ought first to be considered, and the quantity last ; for the advisable quantity depends upon the method.

§ xxxi. It was said above, that the proper treatment or arrangement of ornament was that which expressed the laws and ways of Deity. Now, the subordination of visible orders to each other, just noted, is one expression of these. But there may also—must also—be a subordination and obedience of the parts of each order to some visible law, out of itself, but having reference to itself only (not to any upper order) : some law which shall not oppress, but guide, limit, and sustain.

In the tenth chapter of the second volume of "Modern Painters," the reader will find that I traced one part of the beauty of God's creation to the expression of a *self-restrained* liberty : that is to say, the image of that perfection of *divine* action, which, though free to work in arbitrary methods, works always in consistent methods, called by us Laws.

Now, correspondingly, we find that when these natural objects are to become subjects of the art of man, their perfect

treatment is an image of the perfection of *human* action : a voluntary submission to divine law.

It was suggested to me but lately by the friend to whose originality of thought I have before expressed my obligations, Mr. Newton, that the Greek pediment, with its enclosed sculptures, represented to the Greek mind the law of Fate, confining human action within limits not to be overpassed. I do not believe the Greeks ever distinctly thought of this ; but the instinct of all the human race, since the world began, agrees in some expression of such limitation as one of the first necessities of good ornament.* And this expression is heightened, rather than diminished, when some portion of the design slightly breaks the law to which the rest is subjected ; it is like expressing the use of miracles in the divine government ; or, perhaps, in slighter degrees, the relaxing of a law, generally imperative, in compliance with some more imperative need—the hungering of David. How eagerly this special infringement of a general law was sometimes sought by the mediæval workmen, I shall be frequently able to point out to the reader ; but I remember just now a most curious instance, in an archivolt of a house in the Corte del Remer close to the Rialto at Venice. It is composed of a wreath of flower-work—a constant Byzantine design—with an animal in each coil ; the whole enclosed between two fillets. Each animal, leaping or eating, scratching or biting, is kept nevertheless strictly within its coil, and between the fillets. Not the shake of an ear, not the tip of a tail, overpasses this appointed line, through a series of some five-and-twenty or thirty animals ; until, on a sudden, and by mutual consent, two little beasts (not looking, for the rest, more rampant than the others), one on each side, lay their small paws across the enclosing fillet at exactly the same point of its course, and thus break the continuity of its line. Two ears of corn, or leaves, do the same thing in the

* Some valuable remarks on this subject will be found in a notice of the "Seven Lamps" in the *British Quarterly* for August, 1849. I think, however, the writer attaches too great importance to one out of many ornamental necessities.

mouldings round the northern door of the Baptistery at Florence.

§ xxxii. Observe, however, and this is of the utmost possible importance, that the value of this type does not consist in the mere shutting of the ornament into a certain space, but in the acknowledgment *by* the ornament of the fitness of the limitation—of its own perfect willingness to submit to it; nay, of a predisposition in itself to fall into the ordained form, without any direct expression of the command to do so; an anticipation of the authority, and an instant and willing submission to it, in every fibre and spray: not merely *willing*, but *happy* submission, as being pleased rather than vexed to have so beautiful a law suggested to it, and one which to follow is so justly in accordance with its own nature. You must not cut out a branch of hawthorn as it grows, and rule a triangle round it, and suppose that it is then submitted to law. Not a bit of it. It is only put in a cage, and will look as if it must get out, for its life, or wither in the confinement. But the spirit of triangle must be put into the hawthorn. It must suck in isoscelesism with its sap. Thorn and blossom, leaf and spray, must grow with an awful sense of triangular necessity upon them, for the guidance of which they are to be thankful, and to grow all the stronger and more gloriously. And though there may be a transgression here and there, and an adaptation to some other need, or a reaching forth to some other end greater even than the triangle, yet this liberty is to be always accepted under a solemn sense of special permission; and when the full form is reached and the entire submission expressed, and every blossom has a thrilling sense of its responsibility down into its tiniest stamen, you may take your terminal line away if you will. No need for it any more. The commandment is written on the heart of the thing.

§ xxxiii. Then, besides this obedience to external law, there is the obedience to internal headship, which constitutes the unity of ornament, of which I think enough has been said for my present purpose in the chapter on Unity in the second vol. of "Modern Painters." But I hardly know whether to arrange as an expression of a divine law, or a representation

of a physical fact, the alternation of shade with light which, in equal succession, forms one of the chief elements of *continuous* ornament, and in some peculiar ones, such as dentils and billet mouldings, is the source of their only charm. The opposition of good and evil, the antagonism of the entire human system (so ably worked out by Lord Lindsay), the alternation of labor with rest, the mingling of life with death, or the actual physical fact of the division of light from darkness, and of the falling and rising of night and day, are all typified or represented by these chains of shade and light of which the eye never wearies, though their true meaning may never occur to the thoughts.

§ xxxiv. The next question respecting the arrangement of ornament is one closely connected also with its quantity. The system of creation is one in which "God's creatures leap not, but express a feast, where all the guests sit close, and nothing wants." It is also a feast, where there is nothing redundant. So, then, in distributing our ornament, there must never be any sense of gap or blank, neither any sense of there being a single member, or fragment of a member, which could be spared. Whatever has nothing to do, whatever could go without being missed, is not ornament; it is deformity and encumbrance. Away with it. And, on the other hand, care must be taken either to diffuse the ornament which we permit, in due relation over the whole building, or so to concentrate it, as never to leave a sense of its having got into knots, and curdled upon some points, and left the rest of the building whey. It is very difficult to give the rules, or analyse the feelings, which should direct us in this matter: for some shafts may be carved and others left unfinished, and that with advantage; some windows may be jewelled like Aladdin's, and one left plain, and still with advantage; the door or doors, or a single turret, or the whole western façade of a church, or the apse or transept, may be made special subjects of decoration, and the rest left plain, and still sometimes with advantage. But in all such cases there is either sign of that feeling which I advocated in the First Chapter of the "Seven Lamps," the desire of rather doing some portion of the build-

ing as we would have it, and leaving the rest plain, than doing the whole imperfectly ; or else there is choice made of some important feature, to which, as more honorable than the rest, the decoration is confined. The evil is when, without system, and without preference of the nobler members, the ornament alternates between sickly luxuriance and sudden blankness. In many of our Scotch and English abbeys, especially Melrose, this is painfully felt ; but the worst instance I have ever seen is the window in the side of the arch under the Wellington statue, next St. George's Hospital. In the first place, a window has no business there at all ; in the second, the bars of the window are not the proper place for decoration, especially *wavy* decoration, which one instantly fancies of cast iron ; in the third, the richness of the ornament is a mere patch and eruption upon the wall, and one hardly knows whether to be most irritated at the affectation of severity in the rest, or at the vain luxuriance of the dissolute parallelogram.

§ xxxv. Finally, as regards quantity of ornament I have already said, again and again, you cannot have too much if it be good ; that is, if it be thoroughly united and harmonised by the laws hitherto insisted upon. But you may easily have too much if you have more than you have sense to manage. For with every added order of ornament increases the difficulty of discipline. It is exactly the same as in war : you cannot, as an abstract law, have too many soldiers, but you may easily have more than the country is able to sustain, or than your generalship is competent to command. And every regiment which you cannot manage will, on the day of battle, be in your way, and encumber the movements it is not in disposition to sustain.

§ xxxvi. As an architect, therefore, you are modestly to measure your capacity of governing ornament. Remember, its essence,—its being ornament at all, consists in its being governed. Lose your authority over it, let it command you, or lead you, or dictate to you in any wise, and it is an offence, an incumbrance, and a dishonor. And it is always ready to do this ; wild to get the bit in its teeth, and rush forth on its own devices. Measure, therefore, your strength ; and as long

as there is no chance of mutiny, add soldier to soldier, battalion to battalion ; but be assured that all are heartily in the cause, and that there is not one of whose position you are ignorant, or whose service you could spare.

CHAPTER XXII.

THE ANGLE.

§ I. WE have now examined the treatment and specific kinds of ornament at our command. We have lastly to note the fittest places for their disposal. Not but that all kinds of ornament are used in all places ; but there are some parts of the building, which, without ornament, are more painful than others, and some which wear ornament more gracefully than others ; so that, although an able architect will always be finding out some new and unexpected modes of decoration, and fitting his ornament into wonderful places where it is least expected, there are, nevertheless, one or two general laws which may be noted respecting every one of the parts of a building, laws not (except a few) imperative like those of construction, but yet generally expedient, and good to be understood, if it were only that we might enjoy the brilliant methods in which they are sometimes broken. I shall note, however, only a few of the simplest ; to trace them into their ramifications, and class in due order the known or possible methods of decoration for each part of a building, would alone require a large volume, and be, I think, a somewhat useless work ; for there is often a high pleasure in the very unexpectedness of the ornament, which would be destroyed by too elaborate an arrangement of its kinds.

§ II. I think that the reader must, by this time, so thoroughly understand the connection of the parts of a building, that I may class together, in treating of decoration, several parts which I kept separate in speaking of construction. Thus I shall put under one head (A) the base of the wall and of the shaft ; then (B) the wall veil and shaft itself ; then (C) the cornice and capital ; then (D) the jamb and archivolt, includ-

ing the arches both over shafts and apertures, and the jambs of apertures, which are closely connected with their archivolts; finally (E) the roof, including the real roof, and the minor roofs or gables of pinnacles and arches. I think, under these divisions, all may be arranged which is necessary to be generally stated; for tracery decorations or aperture fillings are but smaller forms of application of the arch, and the cusps are merely smaller spandrils, while buttresses have, as far as I know, no specific ornament. The best are those which have least; and the little they have resolves itself into pinnacles, which are common to other portions of the building, or into small shafts, arches, and niches, of still more general applicability. We shall therefore have only five divisions to examine in succession, from foundation to roof.

§ III. But in the decoration of these several parts, certain



FIG. LI.

minor conditions of ornament occur which are of perfectly general application. For instance, whether, in archivolts, jambs, or buttresses, or in square piers, or at the extremity of the entire building, we necessarily have the awkward (moral or architectural) feature, the *corner*. How to turn a corner gracefully becomes, therefore, a perfectly general question; to be examined without reference to any particular part of the edifice.

§ IV. Again, the furrows and ridges by which bars of parallel light and shade are obtained, whether these are employed in arches, or jambs, or bases, or cornices, must of necessity present one or more of six forms: square projection, *a* (Fig. LI.), or square recess, *b*, sharp projection, *c*, or sharp recess, *d*, curved projection, *e*, or curved recess, *f*. What odd curves the projection or recess may assume, or how these different conditions may be mixed and run into one another, is not our present business. We note only the six distinct kinds or types.

Now, when these ridges or furrows are on a small scale they often themselves constitute all the ornament required for larger features, and are left smooth cut; but on a very large scale they are apt to become insipid, and they require a sub-ornament of their own, the consideration of which is, of course, in great part, general, and irrespective of the place held by the mouldings in the building itself: which consideration I think we had better undertake first of all.

§ v. But before we come to particular examination of these minor forms, let us see how far we can simplify it. Look back to Fig. LL., above. There are distinguished in it six forms of moulding. Of these, *c* is nothing but a small corner; but, for convenience sake, it is better to call it an edge, and to consider its decoration together with that of the member *a*, which is called a fillet; while *e*, which I shall call a roll (because I do not choose to assume that it shall be only of the semicircular section here given), is also best considered together with its relative recess, *f*; and because the shape of a recess is of no great consequence, I shall class all the three recesses together, and we shall thus have only three subjects for separate consideration:—

1. The Angle.
2. The Edge and Fillet.
3. The Roll and Recess.

§ vi. There are two other general forms which may probably occur to the reader's mind, namely, the ridge (as of a roof), which is a corner laid on its back, or sloping,—a supine corner, decorated in a very different manner from a stiff upright corner: and the point, which is a concentrated corner, and has wonderfully elaborate decorations all to its insignificant self, finials, and spikes, and I know not what more. But both these conditions are so closely connected with roofs (even the cusp finial being a kind of pendant to a small roof), that I think it better to class them and their ornament under the head of roof decoration, together with the whole tribe of crockets and bosses; so that we shall be here concerned only

with the three subjects above distinguished: and, first, the corner or Angle.

§ VII. The mathematician knows there are many kinds of angles; but the one we have principally to deal with now, is that which the reader may very easily conceive as the corner of a square house, or square anything. It is of course the one of most frequent occurrence; and its treatment, once understood, may, with slight modification, be referred to other corners, sharper or blunter, or with curved sides.

§ VIII. Evidently the first and roughest idea which would

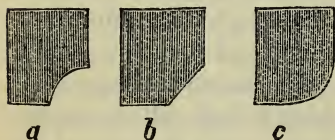

FIG. LII.

occur to any one who found a corner troublesome, would be to cut it off. This is a very summary and tyrannical proceeding, somewhat barbarous, yet advisable if nothing else can be done: an amputated corner is

said to be chamfered. It can, however, evidently be cut off in three ways: 1. with a concave cut, *a*; 2. with a straight cut, *b*; 3. with a convex cut, *c*, Fig. LII.

The first two methods, the most violent and summary, have the apparent disadvantage that we get by them,—two corners instead of one; much milder corners, however, and with a different light and shade between them; so that both methods are often very expedient. You may see the straight chamfer (*b*) on most lamp posts, and pillars at railway stations, it being the easiest to cut: the concave chamfer requires more care, and occurs generally in well-finished but simple architecture—very beautifully in the small arches of the Broletto of Como, Plate V.; and the straight chamfer in architecture of every kind, very constantly in Norman cornices and arches, as in Fig. 2, Plate IV., at Sens.

§ IX. The third, or convex chamfer, as it is the gentlest mode of treatment, so (as in medicine and morals) it is very generally the best. For while the two other methods produce two corners instead of one, this gentle chamfer does verily get rid of the corner altogether, and substitutes a soft curve in its place.

But it has, in the form above given, this grave disadvantage, that it looks as if the corner had been rubbed or worn off, blunted by time and weather, and in want of sharpening again. A great deal often depends, and in such a case as this, everything depends, on the *Voluntariness* of the ornament. The work of time is beautiful on surfaces, but not on edges intended to be sharp. Even if we needed them blunt, we should not like them blunt on compulsion; so, to show that the bluntness is our own ordaining, we will put a slight incised line to mark off the rounding, and show that it goes no farther than we

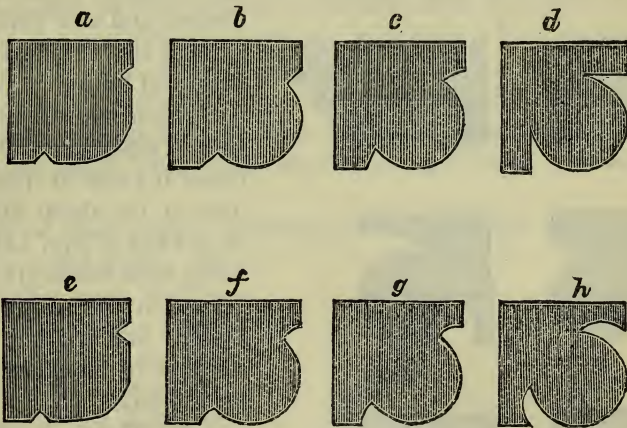

FIG. LIII.

choose. We shall thus have the section *a*, Fig. LIII.; and this mode of turning an angle is one of the very best ever invented. By enlarging and deepening the incision, we get in succession the forms *b*, *c*, *d*; and by describing a small equal arc on each of the sloping lines of these figures, we get *e*, *f*, *g*, *h*.

§ x. I do not know whether these mouldings are called by architects chamfers or beads; but I think *bead* a bad word for a continuous moulding, and the proper sense of the word chamfer is fixed by Spenser as descriptive not merely of truncation, but of trench or furrow:—

“ The gin you, fond flies, the cold to scorn,
 And, crowing in pipes made of green corn,
 You thinken to be lords of the year ;
 But eft when ye count you freed from fear,
 Comes the breme winter with chamfred brows,
 Full of wrinkles and frosty furrows.”

So I shall call the above mouldings beaded chamfers, when there is any chance of confusion with the plain chamfer, *a*, or *b*, of Fig. LII. : and when there is no such chance, I shall use the word chamfer only.

§ XI. Of those above given, *b* is the constant chamfer of

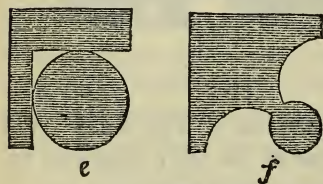
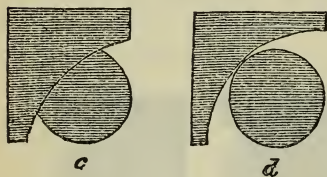
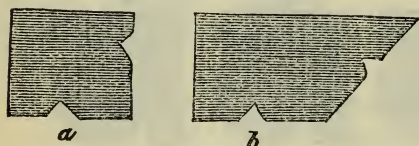

FIG. LIV.

Venice, and *a* of Verona : *a* being the grandest and best, and having a peculiar precision and quaintness of effect about it. I found it twice in Venice, used on the sharp angle, as at *a* and *b*, Fig. LIV., *a* being from the angle of a house on the Rio San Zulian, and *b* from the windows of the church of San Stefano.

§ XII. There is, however, evidently another variety of the chamfers, *f* and *g*, Fig. LIII., formed by an unbroken curve instead of two curves, as *c*, Fig. LIV. ; and when

this, or the chamfer *d*, Fig. LIII., is large, it is impossible to say whether they have been devised from the incised angle, or from small shafts set in a nook, as at *e*, Fig. LIV., or in the hollow of the curved chamfer, as *d*, Fig. LIV. In general, however, the shallow chamfers, *a*, *b*, *e*, and *f*, Fig. LIII., are peculiar to southern work ; and may be assumed to have been derived from the incised angle, while the deep chamfers, *c*, *d*, *g*, *h*, are charac

teristic of northern work, and may be partly derived or imitated from the angle shaft; while, with the usual extravagance of the northern architects, they are cut deeper and deeper until we arrive at the condition *f*, Fig. LIV., which is the favorite chamfer at Bourges and Bayeux, and in other good French work.

I have placed in the Appendix* a figure belonging to this subject, but which cannot interest the general reader, showing the number of possible chamfers with a roll moulding of given size.

§ XIII. If we take the plain chamfer, *b*, of Fig. LIII., on a large scale, as at *a*, Fig. LV., and bead both its edges, cutting away the parts there shaded, we shall have a form much used in richly decorated Gothic, both in England and Italy. It might be more simply described as the chamfer *a* of Fig. LIII., with an incision on each edge; but the part here shaded is often worked into ornamental forms, not being entirely cut away.

§ XIV. Many other mouldings, which at first sight appear very elaborate, are nothing more than a chamfer, with a series of small echoes of it on each side, dying away with a ripple on the surface of the wall, as in *b*, Fig. LV., from Coutances (observe, here the white part is the solid stone, the shade is cut away.)

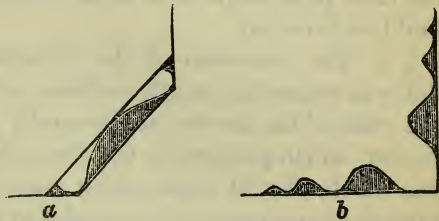

FIG. LV.

Chamfers of this kind are used on a small scale and in delicate work; the coarse chamfers are found on all scales: *f* and *g*, Fig. LIII., in Venice, form the great angles of almost every Gothic palace; the roll being a foot or a foot and a half round, and treated as a shaft, with a capital and fresh base at every story, while the stones of which it is composed form alternate quoins in the brick-work beyond the chamfer curve. I need

* Appendix 23: "Varieties of Chamfer."

hardly say how much nobler this arrangement is than a common quined angle; it gives a finish to the aspect of the whole pile attainable in no other way. And thus much may serve concerning angle decoration by chamfer.

CHAPTER XXIII.

THE EDGE AND FILLET.

§ I. THE decoration of the angle by various forms of chamfer and bead, as above described, is the quietest method we can employ; too quiet, when great energy is to be given to the moulding, and impossible, when, instead of a bold angle, we have to deal with a small projecting edge, like *c* in Fig. LI. In such cases we may employ a decoration, far ruder and easier in its simplest conditions than the bead, far more effective when not used in too great profusion; and of which the complete developments are the source of mouldings at once the most picturesque and most serviceable which the Gothic builders invented.

§ II. The gunwales of the Venetian heavy barges being liable to somewhat rough collision with each other, and with the walls of the streets, are generally protected by a piece of timber, which projects in the form of the fillet, *a*, Fig. LI.; but which, like all other fillets, may, if we so choose, be considered as composed of two angles or edges, which the natural and most wholesome love of the Venetian boatmen for ornament, otherwise strikingly evidenced by their painted sails and glittering flag-vanes, will not suffer to remain wholly undecorated. The rough service of these timbers, however, will not admit of rich ornament, and the boatbuilder usually contents himself with cutting a series of notches in each edge, one series alternating with the other, as represented at 1, Plate IX.

§ III. In that simple ornament, not as confined to Venetian boats, but as representative of a general human instinct to **hack** at an edge, demonstrated by all school-boys and all idle

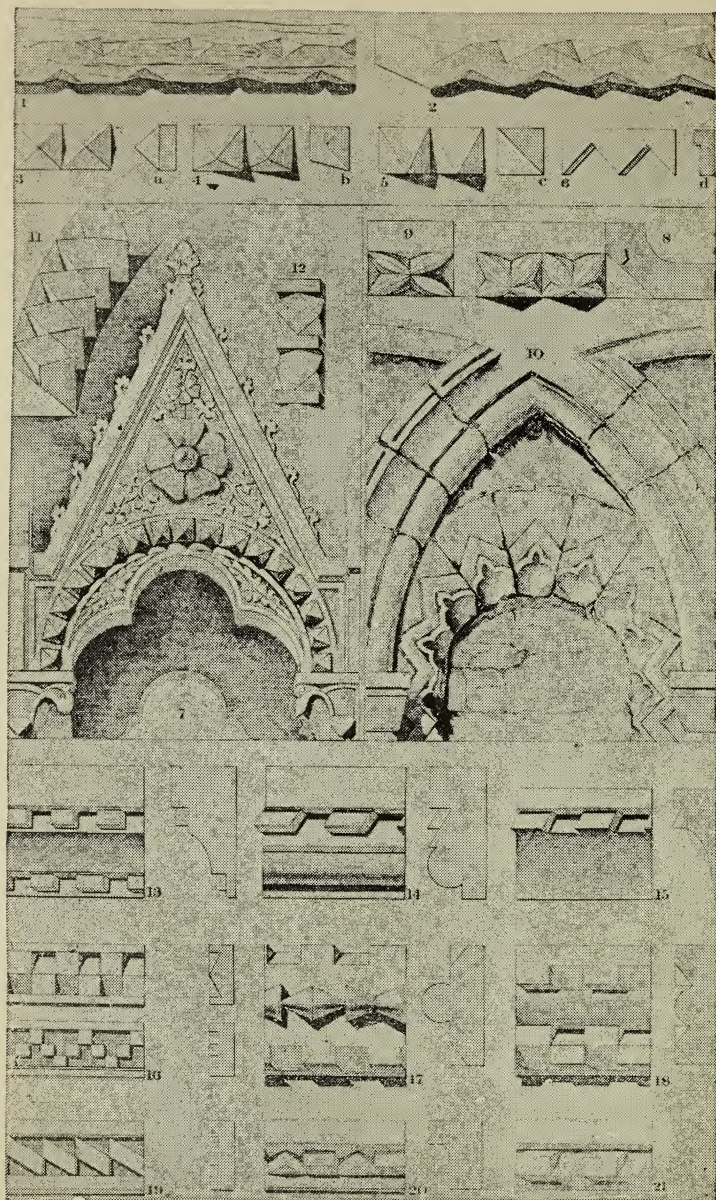

PLATE IX.—EDGE DECORATION.

possessors of penknives or other cutting instruments on both sides of the Atlantic ;—in that rude Venetian gunwale, I say, is the germ of all the ornament which has touched, with its rich successions of angular shadow, the portals and archivolts or nearly every early building of importance, from the North Cape to the Straits of Messina. Nor are the modifications of the first suggestion intricate. All that is generic in their character may be seen on Plate IX. at a glance.

§ IV. Taking a piece of stone instead of timber, and enlarging the notches, until they meet each other, we have the condition 2, which is a moulding from the tomb of the Doge Andrea Dandolo, in St. Mark's. Now, considering this moulding as composed of two decorated edges, each edge will be reduced, by the meeting of the notches, to a series of four-sided pyramids (as marked off by the dotted lines), which, the notches here being shallow, will be shallow pyramids; but by deepening the notches, we get them as at 3, with a profile *a*, more or less steep. This moulding I shall always call "the plain dogtooth;" it is used in profusion in the Venetian and Veronese Gothic, generally set with its front to the spectator, as here at 3; but its effect may be much varied by placing it obliquely (4, and profile as at *b*); or with one side horizontal (5, and profile *c*). Of these three conditions, 3 and 5 are exactly the same in reality, only differently placed; but in 4 the pyramid is obtuse, and the inclination of its base variable, the upper side of it being always kept vertical. It is comparatively rare. Of the three, the last, 5, is far the most brilliant in effect, giving in the distance a zigzag form to the high light on it, and a full sharp shadow below. The use of this shadow is sufficiently seen by fig. 7 in this plate (the arch on the left, the number beneath it), in which these levelled dogteeth, with a small interval between each, are employed to set off by their vigor the delicacy of floral ornament above. This arch is the side of a niche from the tomb of Can Signorino della Scala, at Verona; and the value, as well as the distant expression of its dogtooth, may be seen by referring to Prout's beautiful drawing of this tomb in his "Sketches in France and Italy." I have before observed that this artist never fails

of seizing the true and leading expression of whatever he touches : he has made this ornament the leading feature of the niche, expressing it, as in distance it is only expressible, by a zigzag.

§ v. The reader may perhaps be surprised at my speaking so highly of this drawing, if he take the pains to compare Prout's symbolism of the work on the niche with the facts as they stand here in Plate IX. But the truth is that Prout has rendered the effect of the monument on the mind of the passer-by ;—the effect it was intended to have on every man who turned the corner of the street beneath it : and in this sense there is actually more truth and likeness * in Prout's translation than in my fac-simile, made diligently by peering into the details from a ladder. I do not say that all the symbolism in Prout's Sketch is the best possible ; but it is the best which any architectural draughtsman has yet invented ; and in its application to special subjects it always shows curious internal evidence that the sketch has been made on the spot, and that the artist tried to draw what he saw, not to invent an attractive subject. I shall notice other instances of this hereafter.

§ vi. The dogtooth, employed in this simple form, is, however, rather a foil for other ornament, than itself a satisfactory or generally available decoration. It is, however, easy to enrich it as we choose : taking up its simple form at 3, and describing the arcs marked by the dotted lines upon its sides, and cutting a small triangular cavity between them, we shall leave its ridges somewhat rudely representative of four leaves, as at 8, which is the section and front view of one of the Venetian stone cornices described above, Chap. XIV., § iv., the figure 8 being here put in the hollow of the gutter. The dogtooth is put on the outer lower truncation, and is actually in position as fig. 5 ; but being always looked up to, is to the spectator as 3, and always rich and effective. The dogteeth are perhaps most frequently expanded to the width of fig. 9.

* I do not here speak of artistical merits, but the play of the light among the lower shafts is also singularly beautiful in this sketch of Prout's, and the character of the wild and broken leaves, half dead, on the stone of the foreground.

§ VII. As in nearly all other ornaments previously described, so in this,—we have only to deepen the Italian cutting, and we shall get the Northern type. If we make the original pyramid somewhat steeper, and instead of lightly incising, cut it through, so as to have the leaves held only by their points to the base, we shall have the English dogtooth ; somewhat vulgar in its piquancy, when compared with French mouldings of a similar kind.* It occurs, I think, on one house in Venice, in the Campo St. Polo ; but the ordinary moulding, with light incisions, is frequent in archivolt and architraves, as well as in the roof cornices.

§ VIII. This being the simplest treatment of the pyramid, fig. 10, from the refectory of Wenlock Abbey, is an example of the simplest decoration of the recesses or inward angles between the pyramids ; that is to say, of a simple hacked edge like one of those in fig. 2, the *cuts* being taken up and decorated instead of the *points*. Each is worked into a small trefoiled arch, with an incision round it to mark its outline, and another slight incision above expressing the angle of the first cutting. I said that the teeth in fig. 7 had in distance the effect of a zigzag : in fig. 10 this zigzag effect is seized upon and developed, but with the easiest and roughest work ; the angular incision being a mere limiting line, like that described in § ix. of the last chapter. But hence the farther steps to every condition of Norman ornament are self evident. I do not say that all of them arose from development of the dogtooth in this manner, many being quite independent inventions and uses of zigzag lines ; still, they may all be referred to this simple type as their root and representative, that is to say, the mere hack of the Venetian gunwale, with a limiting line following the resultant zigzag.

§ IX. Fig. 11 is a singular and much more artificial condition, cast in brick, from the church of the Frari, and given here only for future reference. Fig. 12, resulting from a fillet with the cuts on each of its edges interrupted by a bar, is a frequent Venetian moulding, and of great value ; but the plain

* Vide the "Seven Lamps," p. 128.

or leaved dogteeth have been the favorites, and that to such a degree, that even the Renaissance architects took them up; and the best bit of Renaissance design in Venice, the side of the Ducal Palace next the Bridge of Sighs, owes great part of its splendor to its foundation, faced with large flat dogteeth, each about a foot wide in the base, with their points truncated, and alternating with cavities which are their own negatives or casts.

§ x. One other form of the dogtooth is of great importance in northern architecture, that produced by oblique cuts slightly curved, as in the margin, Fig. LVI. It is susceptible of the most fantastic and endless decoration; each of the resulting leaves being, in the early porches of Rouen and Lisieux, hollowed out and worked into branching tracery: and at Bourges, for distant effect, worked into plain leaves, or bold bony processes with knobs at the points, and near the spectator, into crouching demons and broad winged owls, and other fancies and intricacies, innumerable and inexpressible.

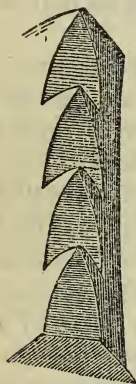

Fig. LVI.

§ xi. Thus much is enough to be noted respecting edge decoration. We were next to consider the fillet. Professor Willis has noticed an ornament, which he has called the Venetian dentil, “as the most universal ornament in its own district that ever I met with;” but has not noticed the reason for its frequency. It is nevertheless highly interesting.

The whole early architecture of Venice is architecture of incrustation: this has not been enough noticed in its peculiar relation to that of the rest of Italy. There is, indeed, much incrustated architecture throughout Italy, in elaborate ecclesiastical work, but there is more which is frankly of brick, or thoroughly of stone. But the Venetian habitually incrustated his work with macre; he built his houses, even the meanest, as if he had been a shell-fish,—roughly inside, mother-of-pearl on the surface: he was content, perforce, to gather the clay of the Brenta banks, and bake it into brick for his sub-

stance of wall ; but he overlaid it with the wealth of ocean, with the most precious foreign marbles. You might fancy early Venice one wilderness of brick, which a petrifying sea had beaten upon till it coated it with marble : at first a dark city—washed white by the sea foam. And I told you before that it was also a city of shafts and arches, and that its dwellings were raised upon continuous arcades, among which the sea waves wandered. Hence the thoughts of its builders were early and constantly directed to the incrustation of arches.

§ XII. In Fig. LVII. I have given two of these Byzantine stilted arches : the one on the right, *a*, as they now too often appear, in its bare brickwork ; that on the left, with its alabaster covering, literally marble defensive armor, riveted together in pieces, which follow the contours of the building. Now,

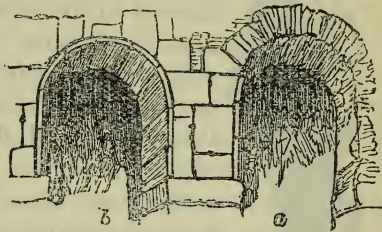

FIG. XVII.

on the wall, these pieces are mere flat slabs cut to the arch outline ; but under the soffit of the arch the marble mail is curved, often cut singularly thin, like bent tiles, and fitted together so that the pieces would sustain each other even without rivets. It is of course desirable that this thin sub-arch of marble should project enough to sustain the facing of the wall ; and the reader will see, in Fig. LVII., that its edge forms a kind of narrow band round the arch (*b*), a band which the least enrichment would render a valuable decorative feature. Now this band is, of course, if the soffit-pieces project a little beyond the face of the wall-pieces, a mere fillet, like the wooden gunwale in Plate IX. ; and the question is, how to enrich it most wisely. It might easily have been dog-toothed, but the Byzantine architects had not invented the dogtooth, and would not have used it here, if they had ; for the dogtooth cannot be employed alone, especially on so principal an angle as this of the main arches, without giving to the whole building a peculiar look, which I can no otherwise describe than as

being to the eye, exactly what untempered acid is to the tongue. The mere dogtooth is an *acid* moulding, and can only be used in certain mingling with others, to give them piquancy ; never alone. What, then, will be the next easiest method of giving interest to the fillet ?

§ XIII. Simply to make the incisions square instead of sharp, and to leave equal intervals of the square edge between them. Fig. LVIII. is one of the curved pieces of arch armor, with its edge thus treated ; one side only being done at the bottom, to show the simplicity and ease of the work. This ornament gives force and interest to the edge of the arch, without in the least diminishing its quietness. Nothing was ever, nor could be ever invented, fitter for its purpose, or more easily cut. From the arch it therefore found its way into every position where the edge of a piece of stone projected, and became, from its constancy of occurrence in the latest Gothic as well as the earliest Byzantine, most truly deserving of the name of the "Venetian Dentil." Its complete intention is now, however, only to be seen in the pictures of Gentile Bellini and Vittor Carpaccio ; for, like most of the rest of the mouldings of Venetian buildings, it was always either gilded or painted—often both, gold being laid on the faces of the dentils, and their recesses colored alternately red and blue.

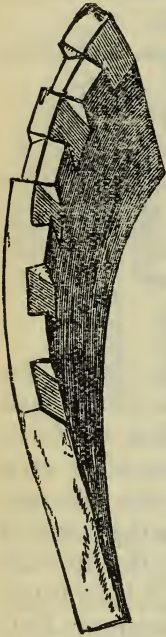

FIG. LVIII.

§ XIV. Observe, however, that the reason above given for the *universality* of this ornament was by no means the reason of its *invention*. The Venetian dentil is a particular application (consequent on the incrustated character of Venetian architecture) of the general idea of dentil, which had been originally given by the Greeks, and realised both by them and by the Byzantines in many laborious forms, long before there was need of them for arch armor ; and the lower half of Plate IX. will give some idea of the conditions which occur in the Romanesque of Venice, distinctly derived from the

classical dentil; and of the gradual transition to the more convenient and simple type, the running-hand dentil, which afterwards became the characteristic of Venetian Gothic. No. 13* is the common dentiled cornice, which occurs repeatedly in St. Mark's; and, as late as the thirteenth century, a reduplication of it, forming the abaci of the capitals of the Piazzetta shafts. Fig. 15 is perhaps an earlier type; perhaps only one of more careless workmanship, from a Byzantine ruin in the Rio di Ca' Foscari: and it is interesting to compare it with fig. 14 from the Cathedral of Vienne, in South France. Fig. 17, from St. Mark's, and 18, from the apse of Murano, are two very early examples in which the future true Venetian dentil is already developed in method of execution, though the object is still only to imitate the classical one; and a rude imitation of the bead is joined with it in fig. 17. No. 16 indicates two examples of experimental forms: the uppermost from the tomb of Mastino della Scala, at Verona; the lower from a door in Venice, I believe, of the thirteenth century: 19 is a more frequent arrangement, chiefly found in cast brick, and connecting the dentils with the dogteeth: 20 is a form introduced richly in the later Gothic, but of rare occurrence until the latter half of the thirteenth century. I shall call it the *gabled* dentil. It is found in the greatest profusion in sepulchral Gothic, associated with several slight variations from the usual dentil type, of which No. 21, from the tomb of Pietro Cornaro, may serve as an example.

§ xv. All the forms given in Plate IX. are of not unfrequent occurrence: varying much in size and depth, according to the expression of the work in which they occur; generally increasing in size in late work (the earliest dentils are seldom more than an inch or an inch and a half long: the fully developed dentil of the later Gothic is often as much as four or five in length, by one and a half in breadth); but they are all somewhat rare, compared to the true or armor dentil, above

* The sections of all the mouldings are given on the right of each; the part which is constantly solid being shaded, and that which is cut into dentils left.

described. On the other hand, there are one or two unique conditions, which will be noted in the buildings where they occur.* The Ducal Palace furnishes three anomalies in the arch, dogtooth, and dentil: it has a hyperbolic arch, as noted above, Chap. X., § xv.; it has a double-fanged dogtooth in the rings of the spiral shafts on its angles; and, finally, it has a dentil with concave sides, of which the section and two of the blocks, real size, are given in Plate XIV. The labor of obtaining this difficult profile has, however, been thrown away; for the effect of the dentil at ten feet distance is exactly the same as that of the usual form: and the reader may consider the dogtooth and dentil in that plate as fairly representing the common use of them in the Venetian Gothic.

§ xvi. I am aware of no other form of fillet decoration requiring notice: in the Northern Gothic, the fillet is employed chiefly to give severity or flatness to mouldings supposed to be too much rounded, and is therefore generally plain. It is itself an ugly moulding, and, when thus employed, is merely a foil for others, of which, however, it at last usurped the place, and became one of the most painful features in the debased Gothic both of Italy and the North.

CHAPTER XXIV.

THE ROLL AND RECESS.

§ I. I HAVE classed these two means of architectural effect together, because the one is in most cases the negative of the other, and is used to relieve it exactly as shadow relieves light; recess alternating with roll, not only in lateral, but in successive order; not merely side by side with each other, but interrupted the one by the other in their own lines. A recess itself

* As, however, we shall not probably be led either to Bergamo or Bologna, I may mention here a curiously rich use of the dentil, entirely covering the foliation and tracery of a niche on the outside of the duomo of Bergamo; and a roll, entirely incrusting, as the handle of a mace often is with nails, with massy dogteeth or nail-heads, on the door of the Pepoli palace of Bologna.

has properly no decoration ; but its depth gives value to the decoration which flanks, encloses, or interrupts it, and the form which interrupts it best is the roll.

§ II. I use the word roll generally for any mouldings which present to the eye somewhat the appearance of being cylindrical, and look like round rods. When upright, they are in appearance, if not in fact, small shafts ; and are a kind of bent shaft, even when used in archivolts and traceries ;—when horizontal, they confuse themselves with cornices, and are, in fact, generally to be considered as the best means of drawing an architectural line in any direction, the soft curve of their side obtaining some shadow at nearly all times of the day, and that more tender and grateful to the eye than can be obtained either by an incision or by any other form of projection.

§ III. Their decorative power is, however, too slight for rich work, and they frequently require, like the angle and the fillet, to be rendered interesting by subdivision or minor ornament of their own. When the roll is small, this is effected, exactly as in the case of the fillet, by cutting pieces out of it ; giving in the simplest results what is called the Norman billet moulding : and when the cuts are given in couples, and the pieces rounded into spheres and almonds, we have the ordinary Greek bead, both of them too well known to require illustration. The Norman billet we shall not meet with in Venice ; the bead constantly occurs in Byzantine, and of course in Renaissance work. In Plate IX., Fig. 17, there is a remarkable example of its early treatment, where the cuts in it are left sharp.

§ IV. But the roll, if it be of any size, deserves better treatment. Its rounded surface is too beautiful to be cut away in notches ; and it is rather to be covered with flat chasing or inlaid patterns. Thus ornamented, it gradually blends itself with the true shaft, both in the Romanesque work of the North, and in the Italian connected schools ; and the patterns used for it are those used for shaft decoration in general.

§ V. But, as alternating with the recess, it has a decoration peculiar to itself. We have often, in the preceding chapters, noted the fondness of the Northern builders for deep shade

and hollowness in their mouldings ; and in the second chapter of the "Seven Lamps," the changes are described which reduced the massive roll mouldings of the early Gothic to a series of recesses, separated by bars of light. The shape of these recesses is at present a matter of no importance to us : it was, indeed, endlessly varied ; but needlessly, for the value of a recess is in its darkness, and its darkness disguises its form. But it was not in mere wanton indulgence of their love of shade that the Flamboyant builders deepened the furrows of their mouldings : they had found a means of decorating those furrows as rich as it was expressive, and the entire framework of their architecture was designed with a view to the effect of this decoration ; where the ornament ceases, the framework is meagre and mean : but the ornament is, in the best examples of the style, unceasing.

§ VI. It is, in fact, an ornament formed by the ghosts or anatomies of the old shafts, left in the furrows which had taken their place. Every here and there, a fragment of a roll or shaft is left in the recess or furrow : a billet-moulding on a huge scale, but a billet-moulding reduced to a skeleton ; for the fragments of roll are cut hollow, and worked into mere entanglement of stony fibres, with the gloom of the recess shown through them. These ghost rolls, forming sometimes pedestals, sometimes canopies, sometimes covering the whole recess with an arch of tracery, beneath which it runs like a tunnel, are the peculiar decorations of the Flamboyant Gothic.

§ VII. Now observe, in all kinds of decoration, we must keep carefully under separate heads, the consideration of the changes wrought in the mere physical form, and in the intellectual purpose of ornament. The relations of the canopy to the statue it shelters, are to be considered altogether distinctly from those of the canopy to the building which it decorates. In its earliest conditions the canopy is partly confused with representations of miniature architecture : it is sometimes a small temple or gateway, sometimes a honorary addition to the pomp of a saint, a covering to his throne, or to his shrine ; and this canopy is often expressed in bas-relief (as in painting), without much reference to the great requirements of the build-

ing. At other times it is a real protection to the statue, and is enlarged into a complete pinnacle, carried on proper shafts, and boldly roofed. But in the late northern system the canopies are neither expressive nor protective. They are a kind of stone lace-work, required for the ornamentation of the building, for which the statues are often little more than an excuse, and of which the physical character is, as above described, that of ghosts of departed shafts.

§ viii. There is, of course, much rich tabernacle work which will not come literally under this head, much which is straggling or flat in its plan, connecting itself gradually with the ordinary forms of independent shrines and tombs; but the general idea of all tabernacle work is marked in the common phrase of a "niche," that is to say a hollow intended for a statue, and crowned by a canopy; and this niche decoration only reaches its full development when the Flamboyant hollows are cut deepest, and when the manner and spirit of sculpture had so much lost their purity and intensity that it became desirable to draw the eye away from the statue to its covering, so that at last the canopy became the more important of the two, and is itself so beautiful that we are often contented with architecture from which profanity has struck the statues, if only the canopies are left; and consequently, in our modern ingenuity, even set up canopies where we have no intention of setting statues.

§ ix. It is a pity that thus we have no really noble example of the effect of the statue in the recesses of architecture: for the Flamboyant recess was not so much a preparation for it as a gulf which swallowed it up. When statues were most earnestly designed, they were thrust forward in all kinds of places, often in front of the pillars, as at Amiens, awkwardly enough, but with manly respect to the purpose of the figures. The Flamboyant hollows yawned at their sides, the statues fell back into them, and nearly disappeared, and a flash of flame in the shape of a canopy rose as they expired.

§ x. I do not feel myself capable at present of speaking with perfect justice of this niche ornament of the north, my late studies in Italy having somewhat destroyed my sympa-

thies with it. But I once loved it intensely, and will not say anything to depreciate it now, save only this, that while I have studied long at Abbeville, without in the least finding that it made me care less for Verona, I never remained long in Verona without feeling some doubt of the nobility of Abbeville.

§ XI. Recess decoration by leaf mouldings is constantly and beautifully associated in the north with niche decoration, but requires no special notice, the recess in such cases being used merely to give value to the leafage by its gloom, and the difference between such conditions and those of the south being merely that in the one the leaves are laid across a hollow, and in the other over a solid surface ; but in neither of the schools exclusively so, each in some degree intermingling the method of the other.

§ XII. Finally the recess decoration by the ball flower is very definite and characteristic, found, I believe, chiefly in English work. It consists merely in leaving a small boss or sphere, fixed, as it were, at intervals in the hollows ; such bosses being afterwards carved into roses, or other ornamental forms, and sometimes lifted quite up out of the hollow, on projecting processes, like vertebræ, so as to make them more conspicuous, as throughout the decoration of the cathedral of Bourges.

The value of this ornament is chiefly in the *spotted* character which it gives to the lines of mouldings seen from a distance. It is very rich and delightful when not used in excess ; but it would satiate and weary the eye if it were ever used in general architecture. The spire of Salisbury, and of St. Mary's at Oxford, are agreeable as isolated masses ; but if an entire street were built with this spotty decoration at every casement, we could not traverse it to the end without disgust. It is only another example of the constant aim at piquancy of effect which characterised the northern builders ; an ingenious but somewhat vulgar effort to give interest to their grey masses of coarse stone, without overtaking their powers either of invention or execution. We will thank them for it without blame or praise, and pass on.

CHAPTER XXV.

THE BASE.

§ I. WE know now as much as is needful respecting the methods of minor and universal decorations, which were distinguished in Chapter XXII., § III., from the ornament which has special relation to particular parts. This local ornament, which, it will be remembered, we arranged in § II. of the same chapter under five heads, we have next, under those heads, to consider. And, first, the ornament of the bases, both of walls and shafts.

It was noticed in our account of the divisions of a wall, that there are something in those divisions like the beginning, the several courses, and the close of a human life. And as, in all well-conducted lives, the hard work, and roughing, and gaining of strength come first, the honor or decoration in certain intervals during their course, but most of all in their close, so, in general, the base of the wall, which is its beginning of labor, will bear least decoration, its body more, especially those epochs of rest called its string courses; but its crown or cornice most of all. Still, in some buildings, all these are decorated richly, though the last most; and in others, when the base is well protected and yet conspicuous, it may probably receive even more decoration than other parts.

§ II. Now, the main things to be expressed in a base are its levelness and evenness. We cannot do better than construct the several members of the base, as developed in Fig. II., p. 66, each of a different colored marble, so as to produce marked level bars of color all along the foundation. This is exquisitely done in all the Italian elaborate wall bases; that of St. Anastasia at Verona is one of the most perfect existing, for play of color; that of Giotto's campanile is on the whole the most beautifully finished. Then, on the vertical portions, *a, b, c*, we may put what patterns in mosaic we please, so that they be not too rich; but if we choose rather to have sculpture (or *must* have it for want of stones to inlay), then observe that all sculpture on bases must be in panels, or it will soon be

worn away, and that a plain panelling is often good without any other ornament. The member *b*, which in St. Mark's is subordinate, and *c*, which is expanded into a seat, are both of them decorated with simple but exquisitely-finished panelling, in red and white or green and white marble; and the member *e* is in bases of this kind very valuable, as an expression of a firm beginning of the substance of the wall itself. This member has been of no service to us hitherto, and was unnoticed in the chapters on construction; but it was expressed in the figure of the wall base, on account of its great value when the foundation is of stone and the wall of brick (coated or not). In such cases it is always better to add the course *e*, above the slope of the base, than abruptly to begin the common masonry of the wall.

§ III. It is, however, with the member *d*, or Xb, that we are most seriously concerned; for this being the essential feature of all bases, and the true preparation for the wall or shaft, it is most necessary that here, if anywhere, we should have full expression of levelness and precision; and farther, that, if possible, the eye should not be suffered to rest on the points of junction of the stones, which would give an effect of instability. Both these objects are accomplished by attracting the eye to two rolls, separated by a deep hollow, in the member *d* itself. The bold projections of their mouldings entirely prevent the attention from being drawn to the joints of the masonry, and besides form a simple but beautifully connected group of bars of shadow, which express, in their perfect parallelism, the absolute levelness of the foundation.

§ IV. I need hardly give any perspective drawing of an arrangement which must be perfectly familiar to the reader, as occurring under nearly every column of the too numerous classical buildings all over Europe. But I may name the base of the Bank of England as furnishing a very simple instance of the group, with a square instead of a rounded hollow, both forming the base of the wall, and gathering into that of the shafts as they occur; while the bases of the pillars of the façade of the British Museum are as good examples as the reader can study on a larger scale.

§ v. I believe this group of mouldings was first invented by the Greeks, and it has never been materially improved, as far as its peculiar purpose is concerned; * the classical attempts at its variation being the ugliest: one, the using a single roll of larger size, as may be seen in the Duke of York's column, which therefore looks as if it stood on a large sausage (the Monument has the same base, but more concealed by pedestal decoration): another, the using two rolls without the intermediate cavetto,—a condition hardly less awkward, and which may be studied to advantage in the wall and shaft-bases of the Athenæum Club-house: and another, the introduction of what are called fillets between the rolls, as may be seen in the pillars of Hanover Chapel, Regent Street, which look, in consequence, as if they were standing upon a pile of pewter collection plates. But the only successful changes have been mediæval; and their nature will be at once understood by a glance at the varieties given on the opposite page. It will be well first to give the buildings in which they occur, in order.

- | | |
|--|-------------------------------------|
| 1. Santa Fosca, Torcello. | 14. Ca' Giustiniani, Venice. |
| 2. North transept, St. Mark's, Venice. | 15. Byzantine fragment, Venice. |
| 3. Nave, Torcello. | 16. St. Mark's, upper Colonnade. |
| 4. Nave, Torcello. | 17. Ducal Palace, Venice (windows). |
| 5. South transept, St. Mark's. | 18. Ca' Falier, Venice. |
| 6. Northern portico, upper shafts, St. Mark's. | 19. St. Zeno, Verona. |
| 7. Another of the same group. | 20. San Stefano, Venice. |
| 8. Cortile of St. Ambrogio, Milan. | 21. Ducal Palace, Venice (windows). |
| 9. Nave shafts, St. Michele, Pavia. | 22. Nave, Salisbury. |
| 10. Outside wall base, St. Mark's, Venice. | 23. Santa Fosca, Torcello. |
| 11. Fondaco de' Turchi, Venice. | 24. Nave, Lyons Cathedral. |
| 12. Nave, Vienne, France. | 25. Notre Dame, Dijon. |
| 13. Fondaco de' Turchi, Venice. | 26. Nave, Bourges Cathedral. |
| | 27. Nave, Mortain (Normandy). |
| | 28. Nave, Rouen Cathedral. |

* Another most important reason for the peculiar sufficiency and value of this base, especially as opposed to the bulging forms of the single or double roll, without the cavetto, has been suggested by the writer

§ VI. Eighteen out of the twenty-eight varieties are Venetian, being bases to which I shall have need of future reference ; but the interspersed examples, 8, 9, 12, and 19, from Milan, Pavia, Vienne (France), and Verona, show the exactly correspondent conditions of the Romanesque base at the period, throughout the centre of Europe. The last five examples show the changes effected by the French Gothic architects : the Salisbury base (22) I have only introduced to show its dulness and vulgarity beside them ; and 23, from Torcello, for a special reason, in that place.

§ VII. The reader will observe that the two bases, 8 and 9, from the two most important Lombardic churches of Italy, St. Ambrogio of Milan and St. Michele of Pavia, mark the character of the barbaric base founded on pure Roman models, sometimes approximating to such models very closely ; and the varieties 10, 11, 13, 16 are Byzantine types, also founded on Roman models. But in the bases 1 to 7 inclusive, and, still more characteristically, in 23 below, there is evidently an original element, a tendency to use the fillet and hollow instead of the roll, which is eminently Gothic ; which in the base 3 reminds one even of Flamboyant conditions, and is excessively remarkable as occurring in Italian work certainly not later than the tenth century, taking even the date of the last rebuilding of the Duomo of Torcello, though I am strongly inclined to consider these bases portions of the original church. And I have therefore put the base 23 among the Gothic group to which it has so strong relationship, though, on the last supposition, five centuries older than the earliest of the five terminal examples ; and it is still more remarkable because it reverses the usual treatment of the lower roll, which is in general a tolerably accurate test of the age of a base, in the degree of its projection. Thus, in the examples 2, 3, 4, 5, 9, 10, 12, the lower roll is hardly rounded at all, and diametrically opposed to the late Gothic conditions, 24 to 28, in which it advances gradually, like a wave preparing of the Essay on the *Æsthetics of Gothic Architecture* in the *British Quarterly* for August, 1849 :—“The Attic base *recedes* at the point where, if it suffered from superincumbent weight, it would bulge out.”

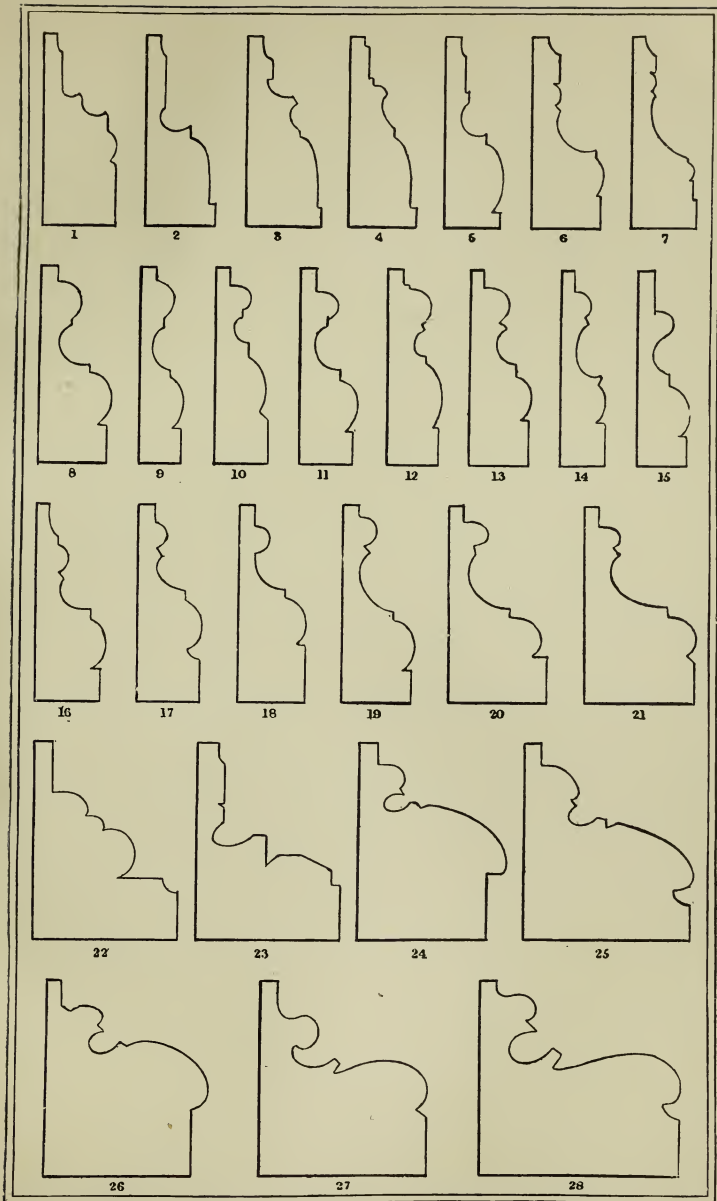

PLATE X.—PROFILES OF BASES.

to break, and at last is actually seen curling over with the long-backed rush of surf upon the shore. Yet the Torcello base resembles these Gothic ones both in expansion beneath and in depth of cavetto above.

§ VIII. There can be no question of the ineffable superiority of these Gothic bases, in grace of profile, to any ever invented by the ancients. But they have all two great faults: They seem, in the first place, to have been designed without sufficient reference to the necessity of their being usually seen from above; their grace of profile cannot be estimated when so seen, and their excessive expansion gives them an appearance of flatness and separation from the shaft, as if they had splashed out under its pressure: in the second place their cavetto is so deeply cut that it has the appearance of a black fissure between the members of the base; and in the Lyons and Bourges shafts, 24 and 26, it is impossible to conquer the idea suggested by it, that the two stones above and below have been intended to join close, but that some pebbles have got in and kept them from fitting; one is always expecting the pebbles to be crushed, and the shaft to settle into its place with a thunder-clap.

§ IX. For these reasons, I said that the profile of the pure classic base had hardly been materially improved; but the various conditions of it are beautiful or commonplace, in proportion to the variety of proportion among their lines and the delicacy of their curvatures; that is to say, the expression of characters like those of the abstract lines in Plate VII.

The five best profiles in Plate X. are 10, 17, 19, 20, 21; 10 is peculiarly beautiful in the opposition between the bold projection of its upper roll, and the delicate leafy curvature of its lower; and this and 21 may be taken as nearly perfect types, the one of the steep, the other of the expansive basic profiles. The characters of all, however, are so dependent upon their place and expression, that it is unfair to judge them thus separately; and the precision of curvature is a matter of so small consequence in general effect, that we need not here pursue the subject farther.

§ X. We have thus far, however, considered only the lines

of moulding in the member X b, whether of wall or shaft base. But the reader will remember that in our best shaft base, in Fig. XII. (p. 87), certain props or spurs were applied to the slope of X b; but now that X b is divided into these delicate mouldings, we cannot conveniently apply the spur to its irregular profile; we must be content to set it against the lower roll. Let the upper edge of this lower roll be the curved line here, *a, d, e, b*, Fig. LIX., and *c* the angle of the square plinth projecting beneath it. Then the spur, applied as we saw in Chap.

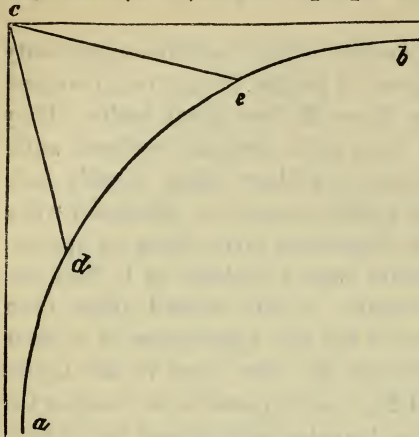

FIG. LIX.

VII., will be of some such form as the triangle *c e d*, Fig. LIX.

§ XI. Now it has just been stated that it is of small importance whether the abstract lines of the profile of a base moulding be fine or not, because we rarely stoop down to look at them. But this triangular spur is nearly always seen from above, and the eye is drawn to it as one of the most important features of the whole base; therefore it is a point of immediate necessity to substitute for its harsh right lines (*c d, c e*) some curve of noble abstract character.

§ XII. I mentioned, in speaking of the line of the salvia leaf at p. 224, that I had marked off the portion of it, *x y*, because I thought it likely to be generally useful to us afterwards; and I promised the reader that as he had built, so he should decorate his edifice at his own free will. If, therefore, he likes the above triangular spur, *c d e*, by all means let him keep it; but if he be on the whole dissatisfied with it, I may be permitted, perhaps, to advise him to set to work like a tapestry bee, to cut off the little bit of line of salvia leaf *x y*, and try how he can best substitute it for the awkward lines *c d c e*. He may try

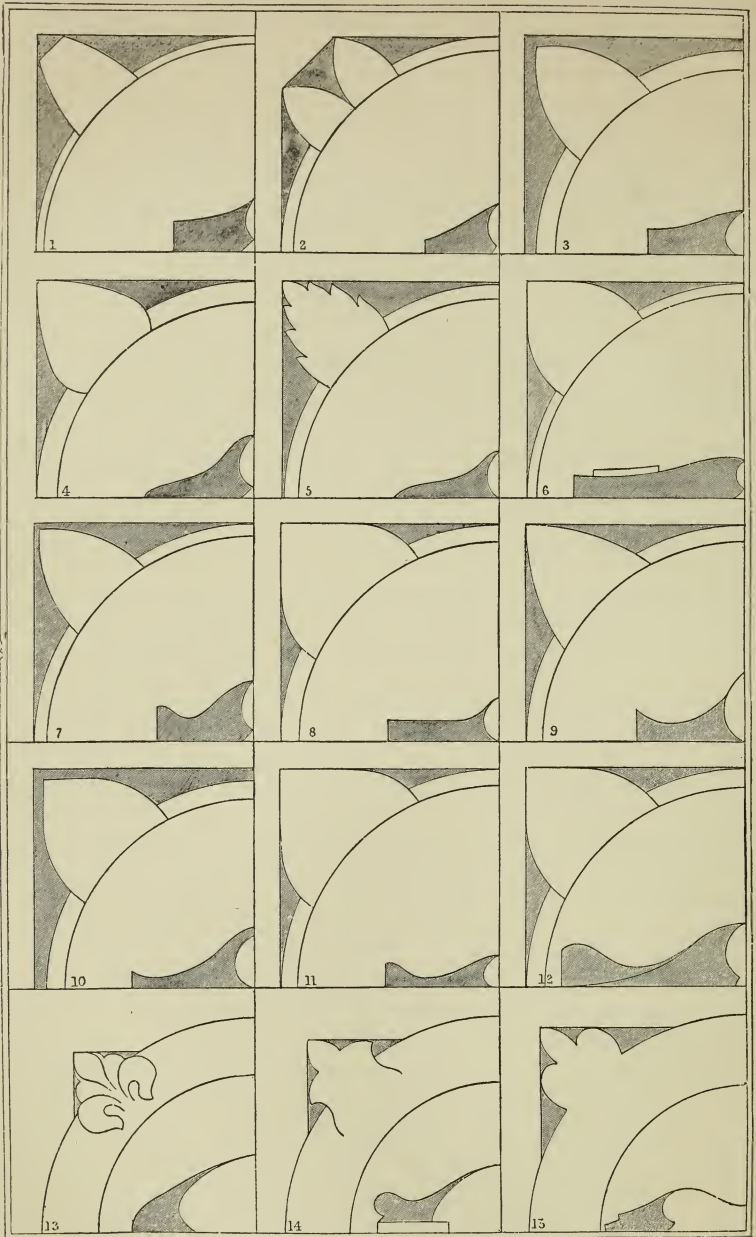

PLATE XI.—PLANS OF BASES.

it any way that he likes; but if he puts the salvia curvature inside the present lines, he will find the spur looks weak, and I think he will determine at last on placing it as I have done at *c d, c e*, Fig. LX. (If the reader will be at the pains to transfer the salvia leaf line with tracing paper, he will find it accurately used in this figure.) Then I merely add an outer circular line to represent the outer swell of the roll against which the spur is set, and I put another such spur to the opposite corner of the square, and we have the half base, Fig. LX., which is a general type of the best Gothic bases in existence, being very nearly that of the upper shafts of the Ducal Palace of Venice.

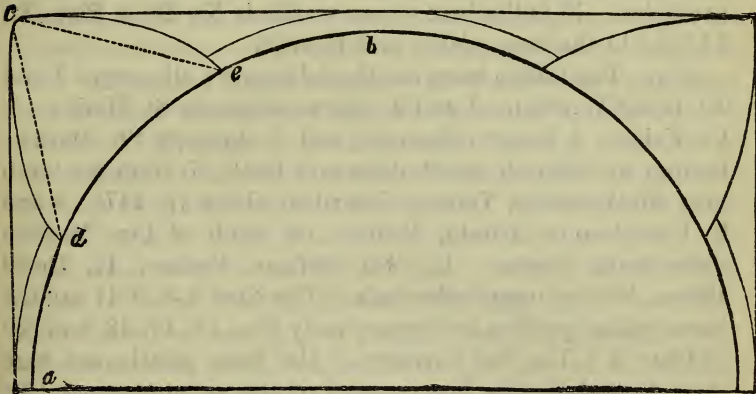

FIG. LX.

In those shafts the quadrant *a b*, or the upper edge of the lower roll, is 2 feet $1\frac{3}{8}$ inches round, and the base of the spur *d e*, is 10 inches; the line *d e* being therefore to *a b* as 10 to $25\frac{3}{8}$. In Fig. LX. it is as 10 to 24, the measurement being easier and the type somewhat more generally representative of the best, *i. e.* broadest, spurs of Italian Gothic.

§ XIII. Now, the reader is to remember, there is nothing magical in salvia leaves: the line I take from them happened merely to fall conveniently on the page, and might as well have been taken from anything else; it is simply its character of gradated curvature which fits it for our use. On Plate XI., opposite, I have given plans of the spurs and quadrants of

twelve Italian and three Northern bases ; these latter (13), from Bourges, (14) from Lyons, (15) from Rouen, are given merely to show the Northern disposition to break up bounding lines, and lose breadth in picturesqueness. These Northern bases look the prettiest in this plate, because this variation of the outline is nearly all the ornament they have, being cut very rudely ; but the Italian bases above them are merely prepared by their simple outlines for far richer decoration at the next step, as we shall see presently. The Northern bases are to be noted also for another grand error : the projection of the roll beyond the square plinth, of which the corner is seen, in various degrees of advancement, in the three examples. 13 is the base whose profile is No. 26 in Plate X ; 14 is 24 in the same plate ; and 15 is 28.

§ xiv. The Italian bases are the following ; all, except 7 and 10, being Venetian : 1 and 2, upper colonnade, St. Mark's ; 3, Ca' Falier ; 4, lower colonnade, and 5, transept, St. Mark's ; 6, from the Church of St. John and Paul ; 7, from the tomb near St. Anastasia, Verona, described above (p. 147) ; 8 and 9, Fon daco de' Turchi, Venice ; 10, tomb of Can Mastino della Scala, Verona ; 11, San Stefano, Venice ; 12, Ducal Palace, Venice, upper colonnade. The Nos. 3, 8, 9, 11 are the bases whose profiles are respectively Nos. 18, 11, 13, and 20 in Plate X. The flat surfaces of the basic plinths are here shaded ; and in the lower corner of the square occupied by each quadrant is put, also shaded, the central profile of each spur, from its root at the roll of the base to its point ; those of Nos. 1 and 2 being conjectural, for their spurs were so rude and ugly, that I took no note of their profiles ; but they would probably be as here given. As these bases, though here, for the sake of comparison, reduced within squares of equal size, in reality belong to shafts of very different size, 9 being some six or seven inches in diameter, and 6, three or four feet, the proportionate size of the roll varies accordingly, being largest, as in 9, where the base is smallest, and in 6 and 12 the leaf profile is given on a larger scale than the plan, or its character could not have been exhibited.

§ xv. Now, in all these spurs, the reader will observe that

the narrowest are for the most part the earliest. No. 2, from the upper colonnade of St. Mark's, is the only instance I ever saw of the double spur, as transitive between the square and octagon plinth; the truncated form, 1, is also rare and very ugly. Nos. 3, 4, 5, 7, and 9 are the general conditions of the Byzantine spur; 8 is a very rare form of plan in Byzantine work, but proved to be so by its rude level profile; while 7, on the contrary, Byzantine in plan, is eminently Gothic in the profile. 9 to 12 are from formed Gothic buildings, equally refined in their profile and plan.

§ xvi. The character of the profile is indeed much altered by the accidental nature of the surface decoration; but the importance of the broad difference between the raised and flat profile will be felt on glancing at the examples 1 to 6 in Plate XII. The three upper examples are the Romanesque types, which occur as parallels with the Byzantine types, 1 to 3 of Plate XI. Their plans would be nearly the same; but instead of resembling flat leaves, they are literally spurs, or claws, as high as they are broad; and the third, from St. Michele of Pavia, appears to be intended to have its resemblance to a claw enforced by the transverse fillet. 1 is from St. Ambrogio, Milan; 2 from Vienne, France. The 4th type, Plate XII., almost like the extremity of a man's foot, is a Byzantine form (perhaps worn on the edges), from the nave of St. Mark's; and the two next show the unity of the two principles, forming the perfect Italian Gothic types,—5, from tomb of Can Signorio della Scala, Verona; 6, from San Stefano, Venice (the base 11 of Plate XI., in perspective). The two other bases, 10 and 12 of Plate XI., are conditions of the same kind, showing the varieties of rise and fall in exquisite modulation; the 10th, a type more frequent at Verona than Venice, in which the spur profile overlaps the roll, instead of rising out of it, and seems to hold it down, as if it were a ring held by sockets. This is a character found both in early and late work; a kind of band, or fillet, appears to hold, and even compress, the *centre* of the roll in the base of one of the crypt shafts of St. Peter's, Oxford, which has also spurs at its angles; and long bands flow over the base of the angle

shaft of the Ducal Palace of Venice, next the *Porta della Carta*.

§ XVII. When the main contours of the base are once determined, its decoration is as easy as it is infinite. I have merely given, in Plate XII., three examples to which I shall need to refer, hereafter. No. 9 is a very early and curious one; the decoration of the base 6 in Plate XI., representing a leaf turned over and flattened down; or, rather, the idea of the turned leaf, worked as well as could be imagined on the flat contour of the spur. Then 10 is the perfect, but simplest possible development of the same idea, from the earliest bases of the upper colonnade of the Ducal Palace, that is to say, the bases of the sea façade; and 7 and 8 are its lateral profile and transverse section. Finally, 11 and 12 are two of the spurs of the later shafts of the same colonnade on the Piazzetta side (No. 12 of Plate XI.). No. 11 occurs on one of these shafts only, and is singularly beautiful. I suspect it to be earlier than the other, which is the characteristic base of the rest of the series, and already shows the loose, sensual, ungoverned character of fifteenth century ornament in the dissoluteness of its rolling.

§ XVIII. I merely give these as examples ready to my hand, and necessary for future reference; not as in anywise representative of the variety of the Italian treatment of the general contour, far less of the endless caprices of the North. The most beautiful base I ever saw, on the whole, is a Byzantine one in the Baptistery of St. Mark's, in which the spur profile approximates to that of No. 10 in Plate XI.; but it is formed by a cherub, who sweeps downwards on the wing. His two wings, as they half close, form the upper part of the spur, and the rise of it in the front is formed by exactly the action of Alichino, swooping on the pitch lake: "*quei drizzo, volando, suso il petto.*" But it requires noble management to confine such a fancy within such limits. The greater number of the best bases are formed of leaves; and the reader may amuse himself as he will by endless inventions of them, from types which he may gather among the weeds at the nearest roadside. The value of the vegetable form is es-

pecially here, as above noted, Chap. XX, § xxxii, its capability of unity with the mass of the base, and of being suggested by few lines; none but the Northern Gothic architects are able to introduce entire animal forms in this position with perfect success. There is a beautiful instance at the north door of the west front of Rouen; a lizard pausing and curling himself round a little in the angle; one expects him the next instant to lash round the shaft and vanish: and we may with advantage compare this base with those of Renaissance Scuola di San Rocca* at Venice, in which the architect, imitating the mediæval bases, which he did not understand, has put an elephant, four inches higher, in the same position.

§ XIX. I have not in this chapter spoken at all of the profiles which are given in Northern architecture to the projections of the lower members of the base, *b* and *c* in Fig. II., nor of the methods in which both these, and the rolls of the mouldings in Plate X., are decorated, especially in Roman architecture, with superadded chainwork or chasing of various patterns. Of the first I have not spoken, because I shall have no occasion to allude to them in the following essay; nor of the second, because I consider them barbarisms. Decorated rolls and decorated ogee profiles, such, for instance, as the base of the Arc de l'Etoile at Paris, are among the richest and farthest refinements of decorative appliances; and they ought always to be reserved for jambs, cornices, and archivolts: if you begin with them in the base, you have no power of refining your decorations as you ascend, and, which is still worse, you put your most delicate work on the jutting portions of the foundation,—the very portions which are most exposed to abrasion. The best expression of a base is that of stern endurance,—the look of being able to bear roughing; or, if the whole building is so delicate that no one

* I have put in Appendix 24, "Renaissance Bases," my memorandum written respecting this building on the spot. But the reader had better delay referring to it, until we have completed our examination of ornaments in shafts and capitals.

can be expected to treat even its base with unkindness,* then at least the expression of quiet, prefatory simplicity. The angle spur may receive such decoration as we have seen, because it is one of the most important features in the whole building ; and the eye is always so attracted to it that it cannot be in rich architecture left altogether blank ; the eye is stayed upon it by its position, but glides, and ought to glide, along the basic rolls to take measurement of their length : and even with all this added fitness, the ornament of the basic spur is best, in the long run, when it is boldest and simplest. The base above described, § xviii., as the most beautiful I ever saw, was not for that reason the best I ever saw : beautiful in its place, in a quiet corner of a Baptistery sheeted with jasper and alabaster, it would have been utterly wrong, nay, even offensive, if used in sterner work, or repeated along a whole colonnade. The base No. 10 of Plate XII. is the richest with which I was ever perfectly satisfied for general service ; and the basic spurs of the building which I have named as the best Gothic monument in the world (p. 147), have no ornament upon them whatever. The adaptation, therefore, of rich cornice and roll mouldings to the level and ordinary lines of bases, whether of walls or shafts, I hold to be one of the worst barbarisms which the Roman and Renaissance architects ever committed ; and that nothing can afterwards redeem the effeminacy and vulgarity of the buildings in which it prominently takes place.

§ xx. I have also passed over, without present notice, the fantastic bases formed by couchant animals, which sustain many Lombardic shafts. The pillars they support have independent bases of the ordinary kind ; and the animal form beneath is less to be considered as a true base (though often exquisitely combined with it, as in the shaft on the southwest angle of the cathedral of Genoa) than as a piece of sculpture, otherwise necessary to the nobility of the building, and deriving its value from its special positive fulfilment of expressional purposes, with which we have here no concern.

* Appendix 25, " Romanist Decoration of Bases."

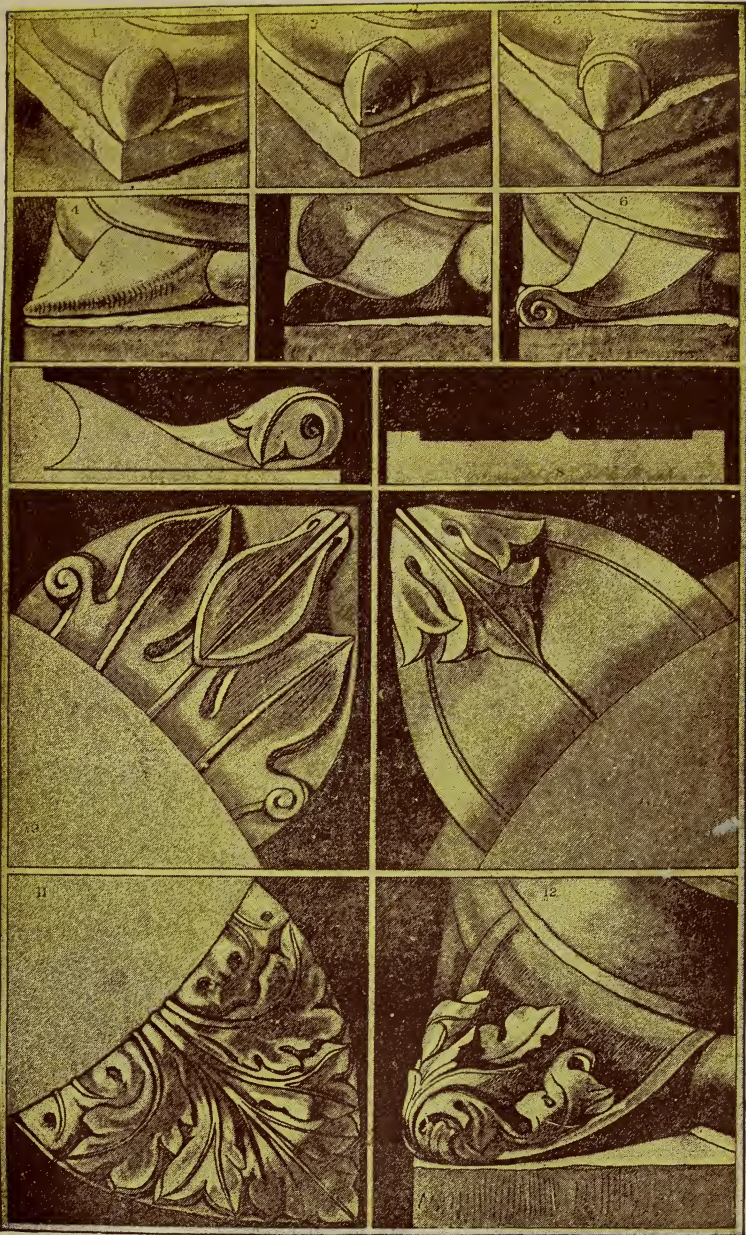

PLATE XII.—DECORATION OF BASES.

As the embodiment of a wild superstition, and the representation of supernatural powers, their appeal to the imagination sets at utter defiance all judgment based on ordinary canons of law; and the magnificence of their treatment atones, in nearly every case, for the extravagance of their conception. I should not admit this appeal to the imagination, if it had been made by a nation in whom the powers of body and mind had been languid; but by the Lombard, strong in all the realities of human life, we need not fear being led astray: the visions of a distempered fancy are not indeed permitted to replace the truth, or set aside the laws of science: but the imagination which is thoroughly under the command of the intelligent will,* has a dominion indiscernible by science, and illimitable by law; and we may acknowledge the authority of the Lombardic gryphons in the mere splendor of their presence, without thinking idolatry an excuse for mechanical misconstruction, or dreading to be called upon, in other cases, to admire a systemless architecture, because it may happen to have sprung from an irrational religion.

CHAPTER XXVI.

THE WALL VEIL AND SHAFT.

§ 1. No subject has been more open ground of dispute among architects than the decoration of the wall veil, because no decoration appeared naturally to grow out of its construction; nor could any curvatures be given to its surface large enough to produce much impression on the eye. It has become, therefore, a kind of general field for experiments of various effects of surface ornament, or has been altogether abandoned to the mosaicist and fresco painter. But we may perhaps conclude, from what was advanced in the Fifth Chap-

* In all the wildness of the Lombardic fancy (described in Appendix 8), this command of the will over its action is as distinct as it is stern. The fancy is, in the early work of the nation, visibly diseased; but never the will, nor the reason.

ter, that there is one kind of decoration which will, indeed, naturally follow on its construction. For it is perfectly natural that the different kinds of stone used in its successive courses should be of different colors; and there are many associations and analogies which metaphysically justify the introduction of horizontal bands of color, or of light and shade. They are, in the first place, a kind of expression of the growth or age of the wall, like the rings in the wood of a tree; then they are a farther symbol of the alternation of light and darkness, which was above noted as the source of the charm of many inferior mouldings: again, they are valuable as an expression of horizontal space to the imagination, space of which the conception is opposed, and gives more effect by its opposition, to the enclosing power of the wall itself (this I spoke of as probably the great charm of these horizontal bars to the Arabian mind): and again they are valuable in their suggestion of the natural courses of rocks, and beds of the earth itself. And to all these powerful imaginative reasons we have to add the merely ocular charm of interlineal opposition of color; a charm so great, that all the best colorists, without a single exception, depend upon it for the most piquant of their pictorial effects, some vigorous mass of alternate stripes or bars of color being made central in all their richest arrangements. The whole system of Tintoret's great picture of the Miracle of St. Mark is poised on the bars of blue, which cross the white turban of the executioner.

§ II. There are, therefore, no ornaments more deeply suggestive in their simplicity than these alternate bars of horizontal colors; nor do I know any buildings more noble than those of the Pisan Romanesque, in which they are habitually employed; and certainly none so graceful, so attractive, so enduringly delightful in their nobleness. Yet, of this pure and graceful ornamentation, Professor Willis says, "a practice more destructive of architectural grandeur can hardly be conceived:" and modern architects have substituted for it the ingenious ornament of which the reader has had one specimen above, Fig. III., p. 72, and with which half the large buildings in London are disfigured, or else traversed by mere straight lines,

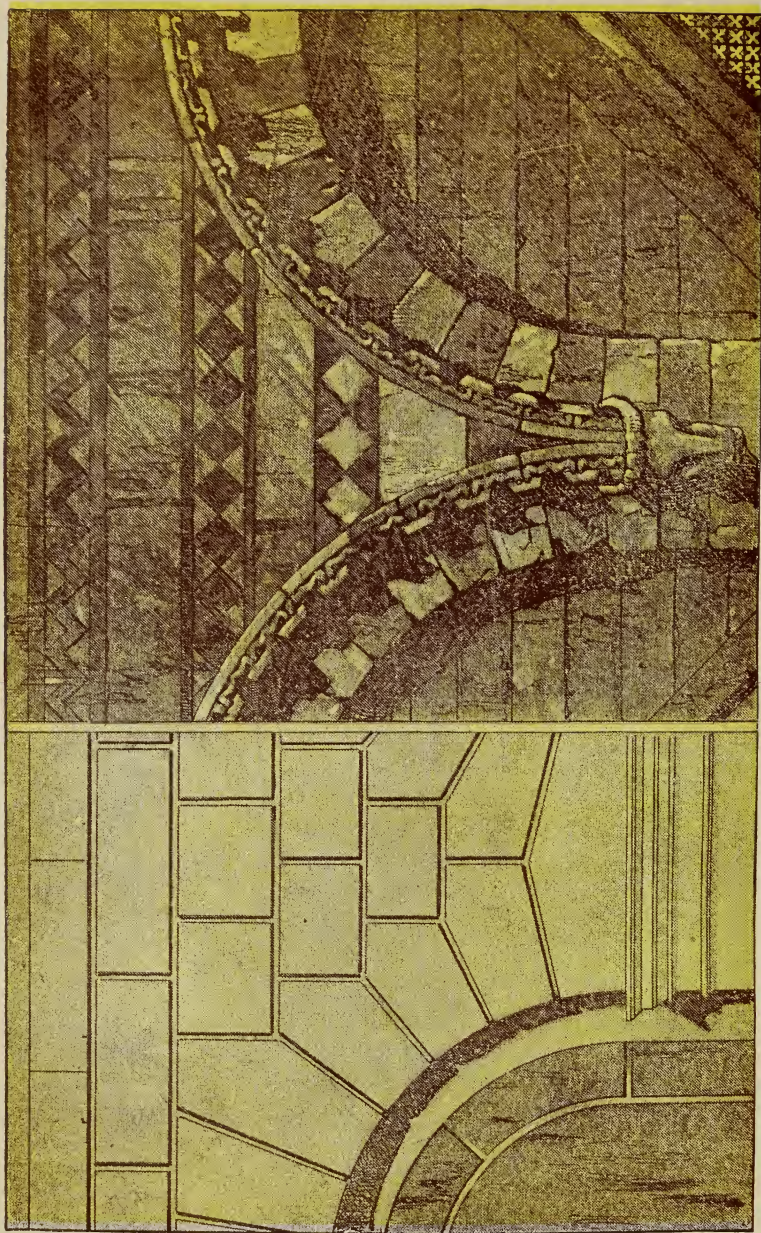

Benaissance.

Romanesque.

PLATE XIII.—WALL-VEIL DECORATION.

as, for instance, the back of the Bank. The lines on the Bank may, perhaps, be considered typical of accounts; but in general the walls, if left destitute of them, would have been as much fairer than the walls charged with them, as a sheet of white paper is than the leaf of a ledger. But that the reader may have free liberty of judgment in this matter, I place two examples of the old and the Renaissance ornament side by side on the opposite page. That on the right is Romanesque, from St. Pietro of Pistoja; that on the left, modern English, from the Arthur Club-house, St. James's Street.

§ III. But why, it will be asked, should the lines which mark the division of the stones be wrong when they are chiselled, and right when they are marked by color? First, because the color separation is a natural one. You build with different kinds of stone, of which, probably, one is more costly than another; which latter, as you cannot construct your building of it entirely, you arrange in conspicuous bars. But the chiselling of the stones is a wilful throwing away of time and labor in defacing the building: it costs much to hew one of those monstrous blocks into shape; and, when it is done, the building is *weaker* than it was before, by just as much stone as has been cut away from its joints. And, secondly, because, as I have repeatedly urged, straight lines are ugly things as *lines*, but admirable as limits of colored spaces; and the joints of the stones, which are painful in proportion to their regularity, if drawn as lines, are perfectly agreeable when marked by variations of hue.

§ IV. What is true of the divisions of stone by chiselling, is equally true of divisions of bricks by pointing. Nor, of course, is the mere horizontal bar the only arrangement in which the colors of brickwork or masonry can be gracefully disposed. It is rather one which can only be employed with advantage when the courses of stone are deep and bold. When the masonry is small, it is better to throw its colors into chequered patterns. We shall have several interesting examples to study in Venice besides the well-known one of the Ducal Palace. The town of Moulins, in France, is one of the most remarkable on this side the Alps for its chequered patterns in

bricks. The church of Christchurch, Streatham, lately built though spoiled by many grievous errors (the iron work in the campanile being the grossest), yet affords the inhabitants of the district a means of obtaining some idea of the variety of effects which are possible with no other material than brick.

§ v. We have yet to notice another effort of the Renaissance architects to adorn the blank spaces of their walls by what is called Rustication. There is sometimes an obscure trace of the remains of the imitation of something organic in this kind of work. In some of the better French eighteenth century buildings it has a distinctly floral character, like a final degradation of Flamboyant leafage ; and some of our modern English architects appear to have taken the decayed teeth of elephants for their type ; but, for the most part, it resembles nothing so much as worm casts ; nor these with any precision. If it did, it would not bring it within the sphere of our properly imitative ornamentation. I thought it unnecessary to warn the reader that he was not to copy forms of refuse or corruption ; and that, while he might legitimately take the worm or the reptile for a subject of imitation, he was not to study the worm cast or coprolite.

§ vi. It is, however, I believe, sometimes supposed that rustication gives an appearance of solidity to foundation stones. Not so ; at least to any one who knows the look of a hard stone. You may, by rustication, make your good marble or granite look like wet slime, honeycombed by sand-eels, or like half-baked tufo covered with slow exudation of stalactite, or like rotten claystone coated with concretions of its own mud ; but not like the stones of which the hard world is built. Do not think that nature rusticates her foundations. Smooth sheets of rock, glistening like sea waves, and that ring under the hammer like a brazen bell,—that is her preparation for first stories. She does rusticate sometimes : crumbly sandstones, with their ripple-marks filled with red mud ; dusty lime-stones, which the rains wash into labyrinthine cavities ; spongy lavas, which the volcano blast drags hither and thither into ropy coils and bubbling hollows ;—these she rusticates,

indeed, when she wants to make oyster-shells and magnesia of them; but not when she needs to lay foundations with them. Then she seeks the polished surface and iron heart, not rough looks and incoherent substance.

§ VII. Of the richer modes of wall decoration it is impossible to institute any general comparison; they are quite infinite, from mere inlaid geometrical figures up to incrustations of elaborate bas-relief. The architect has perhaps more license in them, and more power of producing good effect with rude design than in any other features of the building; the chequer and hatchet work of the Normans and the rude bas-reliefs of the Lombards being almost as satisfactory as the delicate panelling and mosaic of the Duomo of Florence. But this is to be noted of all good wall ornament, that it retains the expression of firm and massive substance, and of broad surface, and that architecture instantly declined when linear design was substituted for massive, and the sense of weight of wall was lost in a wilderness of upright or undulating rods. Of the richest and most delicate wall veil decoration by inlaid work, as practised in Italy from the twelfth to the fifteenth century, I have given the reader two characteristic examples in Plates XX. and XXI.

§ VIII. There are, however, three spaces in which the wall veil, peculiarly limited in shape, was always felt to be fitted for surface decoration of the most elaborate kind; and in these spaces are found the most majestic instances of its treatment, even to late periods. One of these is the spandril space, or the filling between any two arches,

commonly of the shape *a*, Fig. LXI.; the half of which, or the flank filling of any arch, is called a spandril. In Chapter XVII., on Fill-

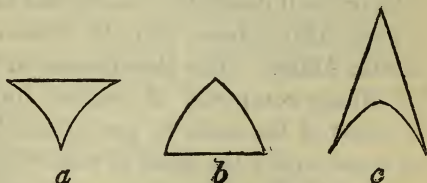

FIG. LXI.

ing of Apertures, the reader will find another of these spaces noted, called the tympanum, and commonly of the form *b*, Fig. LXI.: and finally, in Chapter XVIII., he will find the

third space described, that between an arch and its protecting gable, approximating generally to the form *c*, Fig. LXI.

§ ix. The methods of treating these spaces might alone furnish subject for three very interesting essays; but I shall only note the most essential points respecting them.

(1.) The Spandril. It was observed in Chapter XII, that this portion of the arch load might frequently be lightened with great advantage by piercing it with a circle, or with a group of circles; and the roof of the Euston Square railroad station was adduced as an example. One of the spandril decorations of Bayeux Cathedral is given in the "Seven Lamps," Plate VII. fig. 4. It is little more than one of these Euston Square spandrils, with its circles foliated.

Sometimes the circle is entirely pierced; at other times it is merely suggested by a mosaic or light tracery on the wall surface, as in the plate opposite, which is one of the spandrils of the Ducal Palace at Venice. It was evidently intended that all the spandrils of this building should be decorated in this manner, but only two of them seem to have been completed.*

§ x. The other modes of spandril filling may be broadly reduced to four heads. 1. Free figure sculpture, as in the Chapter-house of Salisbury, and very superbly along the west front of Bourges, the best Gothic spandrils I know. 2. Radiated foliage, more or less referred to the centre, or to the bottom of the spandril for its origin; single figures with expanded wings often answering the same purpose. 3. Trefoils; and 4, ordinary wall decoration continued into the spandril space, as in Plate XIII., above, from St. Pietro at Pistoja, and in Westminster Abbey. The Renaissance architects introduced spandril fillings composed of colossal human figures reclining on the sides of the arch, in precarious lassitude; but these cannot come under the head of wall veil decoration.

§ xi. (2.) The Tympanum. It was noted that, in Gothic architecture, this is for the most part a detached slab of stone, having no constructional relation to the rest of the building. The plan of its sculpture is therefore quite arbitrary; and, as

* Vide end of Appendix 20.

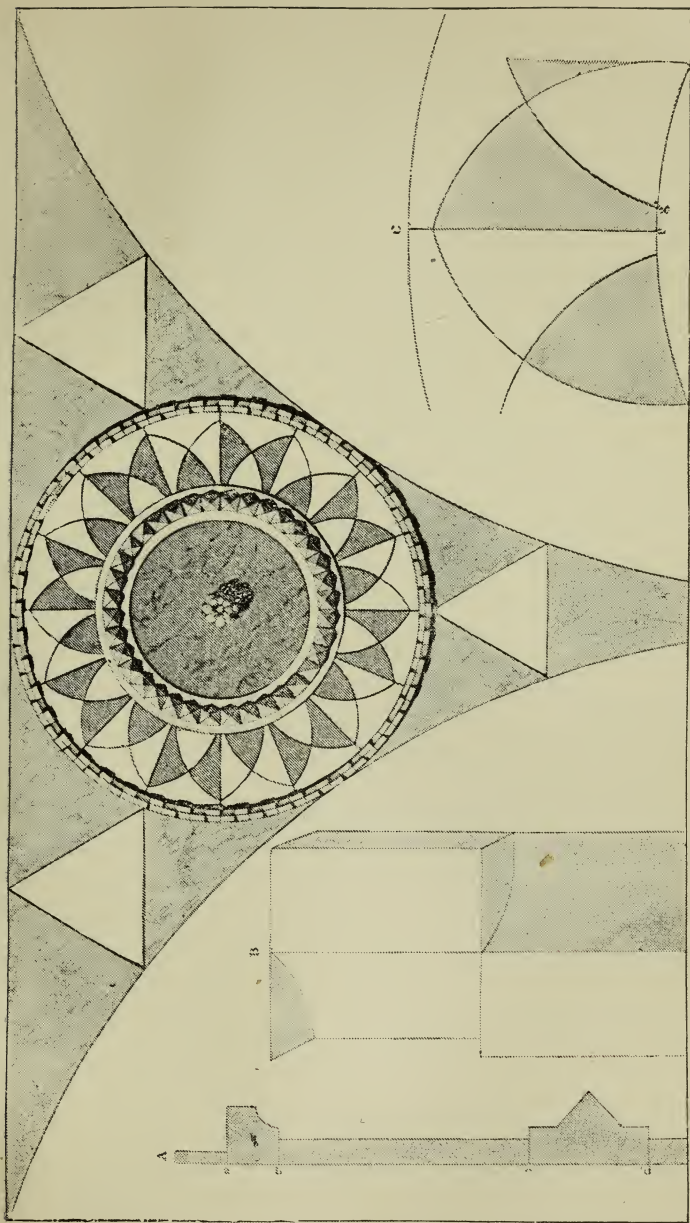

PLATE XIV.—SPANDRIL DECORATION.

it is generally in a conspicuous position, near the eye, and above the entrance, it is almost always charged with a series of rich figure sculptures, solemn in feeling and consecutive in subject. It occupies in Christian sacred edifices very nearly the position of the pediment in Greek sculpture. This latter is itself a kind of tympanum, and charged with sculpture in the same manner.

§ XII. (3.) The Gable. The same principles apply to it which have been noted respecting the spandril, with one more of some importance. The chief difficulty in treating a gable lies in the excessive sharpness of its upper point. It may, indeed, on its outside apex, receive a finial; but the meeting of the inside lines of its terminal mouldings is necessarily both harsh and conspicuous, unless artificially concealed. The most beautiful victory I have ever seen obtained over this difficulty was by placing a sharp shield, its point, as usual, downwards, at the apex of the gable, which exactly reversed the offensive lines, yet without actually breaking them; the gable being completed behind the shield. The same thing is done in the Northern and Southern Gothic: in the porches of Abbeville and the tombs of Verona.

§ XIII. I believe there is little else to be noted of general laws of ornament respecting the wall veil. We have next to consider its concentration in the shaft.

Now the principal beauty of a shaft is its perfect proportion to its work,—its exact expression of necessary strength. If this has been truly attained, it will hardly need, in some cases hardly bear, more decoration than is given to it by its own rounding and taper curvatures; for, if we cut ornaments in intaglio on its surface, we weaken it; if we leave them in relief, we overcharge it, and the sweep of the line from its base to its summit, though deduced in Chapter VIII., from necessities of construction, is already one of gradated curvature, and of high decorative value.

§ XIV. It is, however, carefully to be noted, that decorations are admissible on colossal and on diminutive shafts, which are wrong upon those of middle size. For, when the shaft is enormous, incisions or sculpture on its sides (unless colossal

also), do not materially interfere with the sweep of its curve, nor diminish the efficiency of its sustaining mass. And if it be diminutive, its sustaining function is comparatively of so small importance, the injurious results of failure so much less, and the relative strength and cohesion of its mass so much greater, that it may be suffered in the extravagance of ornament or outline which would be unendurable in a shaft of middle size, and impossible in one of colossal. Thus, the shafts drawn in Plate XIII., of the "Seven Lamps," though given as examples of extravagance, are yet pleasing in the general effect of the arcade they support; being each some six or seven feet high. But they would have been monstrous, as well as unsafe, if they had been sixty or seventy.

§ xv. Therefore, to determine the general rule for shaft decoration, we must ascertain the proportions representative of the mean bulk of shafts: they might easily be calculated from a sufficient number of examples, but it may perhaps be assumed, for our present general purpose, that the mean standard would be of some twenty feet in height, by eight or nine in circumference: then this will be the size on which decoration is most difficult and dangerous: and shafts become more and more fit subjects for decoration, as they rise farther above, or fall farther beneath it, until very small and very vast shafts will both be found to look blank unless they receive some chasing or imagery; blank, whether they support a chair or table on the one side, or sustain a village on the ridge of an Egyptian architrave on the other.

§ xvi. Of the various ornamentation of colossal shafts, there are no examples so noble as the Egyptian; these the reader can study in Mr. Roberts' work on Egypt nearly as well, I imagine, as if he were beneath their shadow, one of their chief merits, as examples of method, being the perfect decision and visibility of their designs at the necessary distance: contrast with these the incrustations of bas-relief on the Trajan pillar, much interfering with the smooth lines of the shaft, and yet themselves untraceable, if not invisible.

§ xvii. On shafts of middle size, the only ornament which has ever been accepted as right, is the Doric fluting, which,

indeed, gave the effect of a succession of unequal lines of shade, but lost much of the repose of the cylindrical gradation. The Corinthian fluting, which is a mean multiplication and deepening of the Doric, with a square instead of a sharp ridge between each hollow, destroyed the serenity of the shaft altogether, and is always rigid and meagre. Both are, in fact, wrong in principle ; they are an elaborate weakening* of the shaft, exactly opposed (as above shown) to the ribbed form, which is the result of a group of shafts bound together, and which is especially beautiful when special service is given to each member.

§ XVIII. On shafts of inferior size, every species of decoration may be wisely lavished, and in any quantity, so only that the form of the shaft be clearly visible. This I hold to be absolutely essential, and that barbarism begins wherever the sculpture is either so bossy, or so deeply cut, as to break the contour of the shaft, or compromise its solidity. Thus, in Plate XXI. (Appendix 8), the richly sculptured shaft of the lower story has lost its dignity and definite function, and become a shapeless mass, injurious to the symmetry of the building, though of some value as adding to its imaginative and fantastic character. Had all the shafts been like it, the façade would have been entirely spoiled ; the inlaid pattern, on the contrary, which is used on the shortest shaft of the upper story, adds to its preciousness without interfering with its purpose, and is every way delightful, as are all the inlaid shaft ornaments of this noble church (another example of them is given in Plate XII. of the "Seven Lamps"). The same rule would condemn the Caryatid ; which I entirely agree with Mr. Fergusson in thinking (both for this and other reasons) one of the chief errors of the Greek schools ; and, more decisively still, the Renaissance inventions of shaft ornament, almost too absurd and too monstrous to be seriously noticed, which consist in leaving square blocks between the cylinder joints, as in the portico of No. 1, Regent Street, and many other buildings in London ; or in rustivating portions of the shafts, or wrap-

* Vide, however, their defence in the Essay above quoted, p. 251.

ping fleeces about them, as at the entrance of Burlington House, in Piccadilly ; or tying drapery round them in knots, as in the new buildings above noticed (Chap. 20, § VII.), at Paris. But, within the limits thus defined, there is no feature capable of richer decoration than the shaft ; the most beautiful examples of all I have seen, are the slender pillars, encrusted with arabesques, which flank the portals of the Baptistery and Duomo at Pisa, and some others of the Pisan and Lucchese churches ; but the varieties of sculpture and inlaying, with which the small Romanesque shafts, whether Italian or Northern, are adorned when they occupy important positions, are quite endless, and nearly all admirable. Mr. Digby Wyatt has given a beautiful example of inlaid work so employed, from the cloisters of the Lateran, in his work on early mosaic ; an example which unites the surface decoration of the shaft



FIG. LXII.

with the adoption of the spiral contour. This latter is often all the decoration which is needed, and none can be more beautiful ; it has been spoken against, like many other good and lovely things, because it has been too often used in extravagant degrees, like the well-known twisting of the pillars in Raffaele's "Beautiful gate." But that extravagant condition was a Renaissance barbarism : the old Romanesque builders kept their spirals slight and pure ; often, as in the example from St. Zeno, in Plate XVII. below, giving only half a turn from the base of the shaft to its head, and nearly always observing what I hold to be an imperative law, that no twisted shaft shall be single, but composed of at least two distinct members, twined with each other. I suppose they followed their own right feeling in doing this, and had never studied natural shafts ; but the type they *might* have followed was caught by one of the few great painters who were not affected by the evil influence of the fifteenth century, Benozzo Gozzoli, who, in the frescoes of the Ricardi Palace, among stems of trees for the most part as vertical as stone shafts, has

suddenly introduced one of the shape given in Fig. LXII. Many forest trees present, in their accidental contortions, types of most complicated spiral shafts, the plan being originally of a grouped shaft rising from several roots; nor, indeed, will the reader ever find models for every kind of shaft decoration, so graceful or so gorgeous, as he will find in the great forest aisle, where the strength of the earth itself seems to rise from the roots into the vaulting; but the shaft surface, barred as it expands with rings of ebony and silver, is fretted with traceries of ivy, marbled with purple moss, veined with grey lichen, and tessellated, by the rays of the rolling heaven, with flitting fancies of blue shadow and burning gold.

CHAPTER XXVII.

THE CORNICE AND CAPITAL.

§ I. THERE ARE no features to which the attention of architects has been more laboriously directed, in all ages, than these crowning members of the wall and shaft; and it would be vain to endeavor, within any moderate limits, to give the reader any idea of the various kinds of admirable decoration which have been invented for them. But, in proportion to the effort and straining of the fancy, have been the extravagances into which it has occasionally fallen; and while it is utterly impossible severally to enumerate the instances either of its success or its error, it is very possible to note the limits of the one and the causes of the other. This is all that we shall attempt in the present chapter, tracing first for ourselves, as in previous instances, the natural channels by which invention is here to be directed or confined, and afterwards remarking the places where, in real practice, it has broken bounds.

§ II. The reader remembers, I hope, the main points respecting the cornice and capital, established above in the Chapters on Construction. Of these I must, however, recapitulate thus much :—

1. That both the cornice and capital are, with reference to the *slope* of their profile or bell, to be divided into two great orders; in one of which the ornament is convex, and in the other concave. (Ch. VI., § v.)

2. That the capital, with reference to the method of twisting the cornice round to construct it, and to unite the circular shaft with the square abacus, falls into five general forms, represented in Fig. XXII., p. 117.

3. That the most elaborate capitals were formed by true or simple capitals with a common cornice added above their abacus. (Ch. IX., § xxiv.)

We have then, in considering decoration, first to observe the treatment of the two great orders of the cornice; then their gathering into the five of the capital; then the addition of the secondary cornice to the capital when formed.

§ III. The two great orders or families of cornice were above distinguished in Fig. V., p. 75.; and it was mentioned in the same place that a third family arose from their combination. We must deal with the two great opposed groups first.

They were distinguished in Fig. V. by circular curves drawn on opposite sides of the same line. But we now know that in these smaller features the circle is usually the least interesting curve that we can use; and that it will be well, since the capital and cornice are both active in their expression, to use some of the more abstract natural lines. We will go back, therefore, to our old friend the salvia leaf; and taking the same piece of it we had before, *x y*, Plate VII., we will apply it to the cornice line; first within it, giving the concave cornice, then without, giving the convex cornice. In all the figures, *a, b, c, d*, Plate XV., the dotted line is at the same slope, and represents an average profile of the root of cornices (*a*, Fig. V., p. 75); the curve of the salvia leaf is applied to it in each case, first with its roundest curvature up, then with its roundest curvature down; and we have thus the two varieties, *a* and *b*, of the concave family, and *c* and *d*, of the convex family.

§ IV. These four profiles will represent all the simple cor-

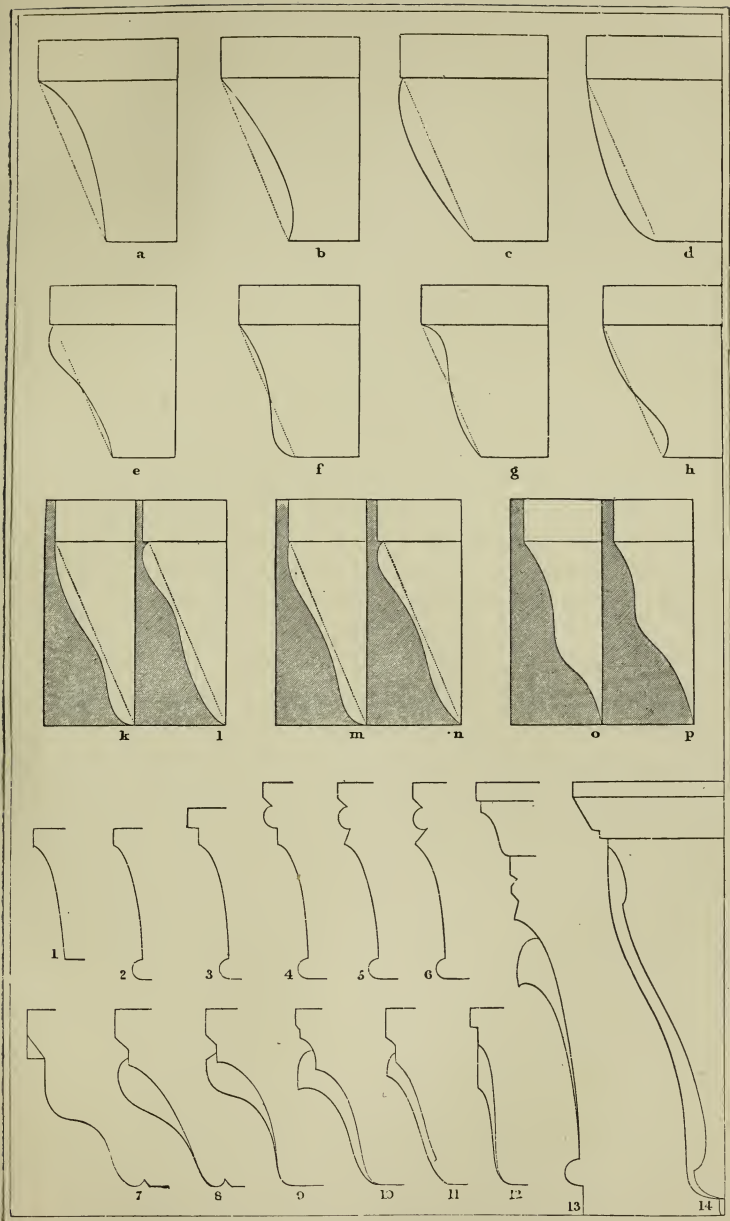

PLATE XV.—CORNICIE PROFILES.

nices in the world ; represent them, I mean, as central types : for in any of the profiles an infinite number of slopes may be given to the dotted line of the root (which in these four figures is always at the same angle) ; and on each of these innumerable slopes an innumerable variety of curves may be fitted, from every leaf in the forest, and every shell on the shore, and every movement of the human fingers and fancy ; therefore, if the reader wishes to obtain something like a numerical representation of the number of possible and beautiful cornices which may be based upon these four types or roots, and among which the architect has leave to choose according to the circumstances of his building and the method of its composition, let him set down a figure 1 to begin with, and write cyphers after it as fast as he can, without stopping, for an hour.

§ v. None of the types are, however, found in perfection of curvature, except in the best work. Very often cornices are worked with circular segments (with a noble, massive effect, for instance, in St. Michele of Lucca), or with rude approximation to finer curvature, especially *a*, Plate XV., which occurs often so small as to render it useless to take much pains upon its curve. It occurs perfectly pure in the condition represented by 1 of the series 1—6, in Plate XV., on many of the Byzantine and early Gothic buildings of Venice ; in more developed form it becomes the profile of the bell of the capital in the later Venetian Gothic, and in much of the best Northern Gothic. It also represents the Corinthian capital, in which the curvature is taken from the bell to be added in some excess to the nodding leaves. It is the most graceful of all simple profiles of cornice and capital.

§ vi. *b* is a much rarer and less manageable type : for this evident reason, that while *a* is the natural condition of a line rooted and strong beneath, but bent out by superincumbent weight, or nodding over in freedom, *b* is yielding at the base and rigid at the summit. It has, however, some exquisite uses, especially in combination, as the reader may see by glancing in advance at the inner line of the profile 14 in Plate XV.

§ VII. *c* is the leading convex or Doric type, as *a* is the leading concave or Corinthian. Its relation to the best Greek Doric is exactly what the relation of *a* is to the Corinthian; that is to say, the curvature must be taken from the straighter limb of the curve and added to the bolder bend, giving it a sudden turn inwards (as in the Corinthian a nod outwards), as the reader may see in the capital of the Parthenon in the British Museum, where the lower limb of the curve is *all but* a right line.* But these Doric and Corinthian lines are mere varieties of the great families which are represented by the central lines *a* and *c*, including not only the Doric capital, but all the small cornices formed by a slight increase of the curve of *c*, which are of so frequent occurrence in Greek ornaments.

§ VIII. *d* is the Christian Doric, which I said (Chap. I., § xx.) was invented to replace the antique: it is the representative of the great Byzantine and Norman families of convex cornice and capital, and, next to the profile *a*, the most important of the four, being the best profile for the convex capital, as *a* is for the concave; *a* being the best expression of an elastic line inserted vertically in the shaft, and *d* of an elastic line inserted horizontally and rising to meet vertical pressure.

If the reader will glance at the arrangements of boughs of trees, he will find them commonly dividing into these two families, *a* and *d*: they rise out of the trunk and nod from it, as *a*, or they spring with sudden curvature out from it, and rise into sympathy with it, as at *d*; but they only accidentally display tendencies to the lines *b* or *c*. Boughs which fall as they spring from the tree also describe the curve *d* in the plurality of instances, but reversed in arrangement; their junction with the stem being at the top of it, their sprays bending out into rounder curvature.

§ IX. These then being the two primal groups, we have next to note the combined group, formed by the concave and convex lines joined in various proportions of curvature, so as to form together the reversed or ogee curve, represented in

* In very early Doric it was an absolute right line; and that capital is therefore derived from the pure cornice root, represented by the dotted line.

one of its most beautiful states by the glacier line *a*, on Plate VII. I would rather have taken this line than any other to have formed my third group of cornices by, but as it is too large, and almost too delicate, we will take instead that of the Matterhorn side, *e f*, Plate VII. For uniformity's sake I keep the slope of the dotted line the same as in the primal forms; and applying this Matterhorn curve in its four relative positions to that line, I have the types of the four cornices or capitals of the third family, *e, f, g, h*, on Plate XV.

These are, however, general types only thus far, that their line is composed of one short and one long curve, and that they represent the four conditions of treatment of every such line; namely, the longest curve concave in *e* and *f*, and convex in *g* and *h*; and the point of contrary flexure set high in *e* and *g*, and low in *f* and *h*. The relative depth of the arcs, or nature of their curvature, cannot be taken into consideration without a complexity of system which my space does not admit.

Of the four types thus constituted, *e* and *f* are of great importance; the other two are rarely used, having an appearance of weakness in consequence of the shortest curve being concave: the profiles *e* and *f*, when used for cornices, have usually a fuller sweep and somewhat greater equality between the branches of the curve; but those here given are better representatives of the structure applicable to capitals and cornices indifferently.

§ x. Very often, in the farther treatment of the profiles *e* or *f*, another limb is added to their curve in order to join it to the upper or lower members of the cornice or capital. I do not consider this addition as forming another family of cornices, because the leading and effective part of the curve is in these, as in the others, the single ogee; and the added bend is merely a less abrupt termination of it above or below: still this group is of so great importance in the richer kinds of ornamentation that we must have it sufficiently represented. We shall obtain a type of it by merely continuing the line of the Matterhorn side, of which before we took only a fragment. The entire line *e* to *g* on Plate VII., is evidently composed of

three curves of unequal lengths, which if we call the shortest 1, the intermediate one 2, and the longest 3, are there arranged in the order 1, 3, 2, counting upwards. But evidently we might also have had the arrangements 1, 2, 3, and 2, 1, 3, giving us three distinct lines, altogether independent of position, which being applied to one general dotted slope will each give four cornices, or twelve altogether. Of these the six most important are those which have the shortest curve convex: they are given in light relief from *k* to *p*, Plate XV., and, by turning the page upside down, the other six will be seen in dark relief, only the little upright bits of shadow at the bottom are not to be considered as parts of them, being only admitted in order to give the complete profile of the more important cornices in light.

§ XI. In these types, as in *e* and *f*, the only general condition is, that their line shall be composed of three curves of different lengths and different arrangements (the depth of arcs and radius of curvatures being unconsidered). They are arranged in three couples, each couple being two positions of the same entire line; so that numbering the component curves in order of magnitude and counting upwards, they will read—

k 1, 2, 3,
l 3, 2, 1,
m 1, 3, 2,
n 2, 3, 1,
o 2, 1, 3,
p 3, 1, 2.

m and *n*, which are the *Matterhorn line*, are the most beautiful and important of all the twelve; *k* and *l* the next; *o* and *p* are used only for certain conditions of flower carving on the surface. The reverses (dark) of *k* and *l* are also of considerable service; the other four hardly ever used in good work.

§ XII. If we were to add a fourth curve to the component series, we should have forty-eight more cornices: but there is no use in pursuing the system further, as such arrange-

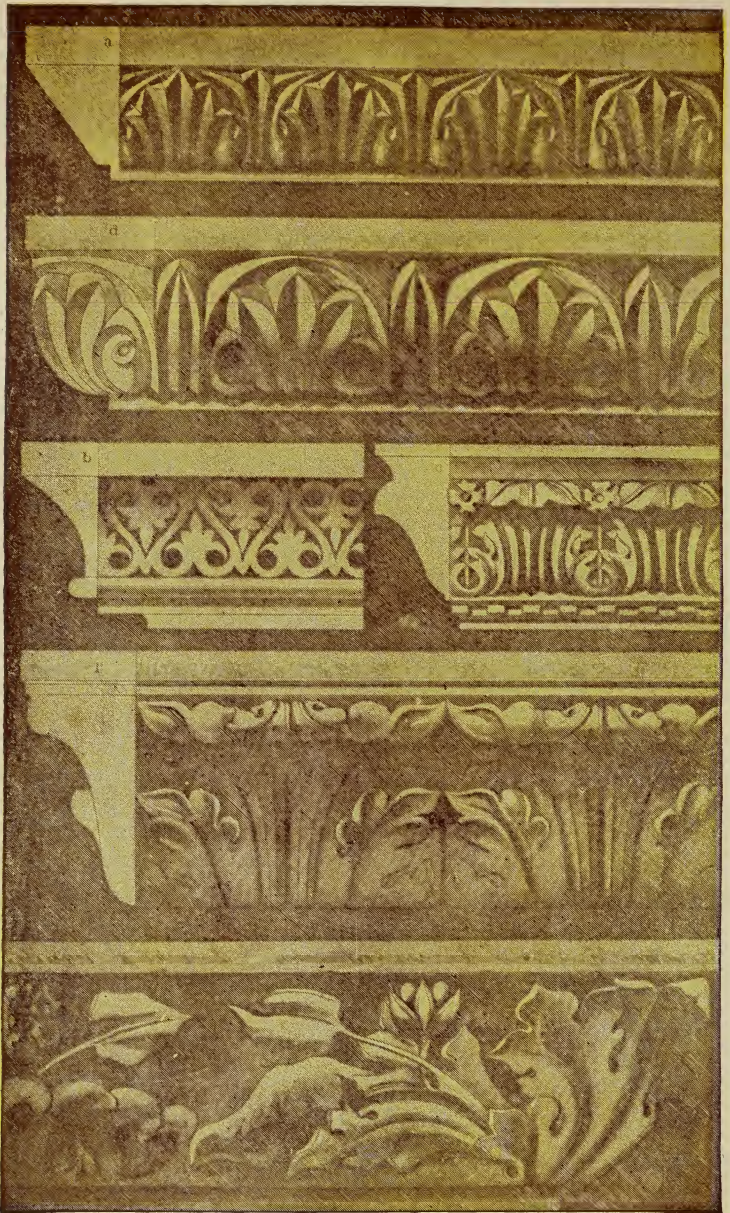

PLATE XVI.—CORNICE DECORATION.

ments are very rare and easily resolved into the simpler types with certain arbitrary additions fitted to their special place ; and, in most cases, distinctly separate from the main curve, as in the inner line of No. 14, which is a form of the type *e*, the longest curve, *i.e.*, the lowest, having deepest curvature, and each limb opposed by a short contrary curve at its extremities, the convex limb by a concave, the concave by a convex.

§ XIII. Such, then, are the great families of profile lines into which all cornices and capitals may be divided ; but their best examples unite two such profiles in a mode which we cannot understand till we consider the further ornament with which the profiles are charged. And in doing this we must, for the sake of clearness, consider, first the nature of the designs themselves, and next the mode of cutting them.

§ XIV. In Plate XVI., opposite, I have thrown together a few of the most characteristic mediæval examples of the treatment of the simplest cornice profiles : the uppermost, *a*, is the pure root of cornices from St. Mark's. The second, *d*, is the Christian Doric cornice, here lettered *d* in order to avoid confusion, its profile being *d* of Plate XV. in bold development, and here seen on the left-hand side, truly drawn, though filled up with the ornament to show the mode in which the angle is turned. This is also from St. Mark's. The third, *b*, is *b* of Plate XV., the pattern being inlaid in black because its office was in the interior of St. Mark's, where it was too dark to see sculptured ornament at the required distance. (The other two simple profiles, *a* and *c* of Plate XV., would be decorated in the same manner, but require no example here, for the profile *a* is of so frequent occurrence that it will have a page to itself alone in the next volume ; and *c* may be seen over nearly every shop in London, being that of the common Greek egg cornice.) The fourth, *e* in Plate XVI., is a transitional cornice, passing from Byzantine into Venetian Gothic : *f* is a fully developed Venetian Gothic cornice founded on Byzantine traditions ; and *g* the perfect Lombardic-Gothic cornice, founded on the Pisan Romanesque traditions, and strongly marked with the noblest Northern element, the Lom-

bardic vitality restrained by classical models. I consider it a perfect cornice, and of the highest order.

§ xv. Now in the design of this series of ornaments there are two main points to be noted; the first, that they all, except *b*, are distinctly rooted in the lower part of the cornice, and spring to the top. This arrangement is constant in all the best cornices and capitals; and it is essential to the expression of the supporting power of both. It is exactly opposed to the system of *running* cornices and *banded** capitals, in which the ornament flows along them horizontally, or is twined round them, as the mouldings are in the early English capital, and the foliage in many decorated ones. Such cornices have arisen from a mistaken appliance of the running ornaments, which are proper to archivolts, jambs, &c., to the features which have definite functions of support. A tendril may nobly follow the outline of an arch, but must not creep along a cornice, nor swathe or bandage a capital; it is essential to the expression of these features that their ornament should have an elastic and upward spring; and as the proper profile for the curve is that of a tree bough, as we saw above, so the proper arrangement of its farther ornament is that which best expresses rooted and ascendant strength like that of foliage.

There are certain very interesting exceptions to the rule (we shall see a curious one presently); and in the carrying out of the rule itself, we may see constant licenses taken by the great designers, and momentary violations of it, like those above spoken of, respecting other ornamental laws—violations which are for our refreshment, and for increase of delight in the general observance; and this is one of the peculiar beauties of the cornice *g*, which, rooting itself in strong central clusters, suffers some of its leaves to fall languidly aside, as the drooping outer leaves of a natural cluster do so often; but at the very instant that it does this, in order that it may not

* The word *banded* is used by Professor Willis in a different sense; which I would respect, by applying it in his sense always to the Impost, and in mine to the capital itself. (This note is not for the general reader, who need not trouble himself about the matter.)

lose any of its expression of strength, a fruit-stalk is thrown up above the languid leaves, absolutely vertical, as much stiffer and stronger than the rest of the plant as the falling leaves are weaker. Cover this with your finger, and the cornice falls to pieces, like a bouquet which has been untied.

§ XVI. There are some instances in which, though the real arrangement is that of a running stem, throwing off leaves up and down, the positions of the leaves give nearly as much elasticity and organisation to the cornice, as if they had been rightly rooted; and others, like *b*, where the reversed portion of the ornament is lost in the shade, and the general expression of strength is got by the lower member. This cornice will, nevertheless, be felt at once to be inferior to the rest; and though we may often be called upon to admire designs of these kinds, which would have been exquisite if not thus misplaced, the reader will find that they are both of rare occurrence, and significative of declining style; while the greater mass of the banded capitals are heavy and valueless, mere aggregations of confused sculpture, swathed round the extremity of the shaft, as if she had dipped it into a mass of melted ornament, as the glass-blower does his blow-pipe into the metal, and brought up a quantity adhering glutinously to its extremity. We have many capitals of this kind in England: some of the worst and heaviest in the choir of York. The later capitals of the Italian Gothic have the same kind of effect, but owing to another cause: for their structure is quite pure, and based on the Corinthian type: and it is the branching form of the heads of the leaves which destroys the effect of their organisation. On the other hand, some of the Italian cornices which are actually composed by running tendrils, throwing off leaves into oval interstices, are so massive in their treatment, and so marked and firm in their vertical and arched lines, that they are nearly as suggestive of support as if they had been arranged on the rooted system. A cornice of this kind is used in St. Michele of Lucca (Plate VI. in the "Seven Lamps," and XXI. here), and with exquisite propriety; for that cornice is at once a crown to the story beneath it and a foundation to that which is above it, and therefore unites the

strength and elasticity of the lines proper to the cornice with the submission and prostration of those proper to the foundation.

§ xvii. This, then, is the first point needing general notice in the designs in Plate XVI. The second is the difference between the freedom of the Northern and the sophistication of the classical cornices, in connection with what has been advanced in Appendix 8. The cornices, *a*, *d*, and *b*, are of the same date, but they show a singular difference in the workman's temper: that at *b* is a single copy of a classical mosaic; and many carved cornices occur, associated with it, which are, in like manner, mere copies of the Greek and Roman egg and arrow mouldings. But the cornices *a* and *d* are copies of nothing of the kind: the idea of them has indeed been taken from the Greek honeysuckle ornament, but the chiselling of them is in no wise either Greek, or Byzantine, in temper. The Byzantines were languid copyists: this work is as energetic as its original; energetic, not in the quantity of work, but in the spirit of it: an indolent man, forced into toil, may cover large spaces with evidence of his feeble action, or accumulate his dulness into rich aggregation of trouble, but it is gathered weariness still. The man who cut those two uppermost cornices had no time to spare: did as much cornice as he could in half an hour; but would not endure the slightest trace of error in a curve, or of bluntness in an edge. His work is absolutely unreprouvable; keen, and true, as Nature's own; his entire force is in it, and fixed on seeing that every line of it shall be sharp and right: the faithful energy is in him: we shall see something come of that cornice: The fellow who inlaid the other (*b*), will stay where he is for ever; and when he has inlaid one leaf up, will inlay another down,—and so undulate up and down to all eternity: but the man of *a* and *d* will cut his way forward, or there is no truth in handicrafts, nor stubbornness in stone.

§ xviii. But there is something else noticeable in those two cornices, besides the energy of them: as opposed either to *b*, or the Greek honeysuckle or egg patterns, they are *natural* designs. The Greek egg and arrow cornice is a nonsense

cornice, very noble in its lines, but utterly absurd in meaning. Arrows have had nothing to do with eggs (at least since Leda's time), neither are the so-called arrows like arrows, nor the eggs like eggs, nor the honeysuckles like honeysuckles; they are all conventionalised into a monotonous successiveness of nothing,—pleasant to the eye, useless to the thought. But those Christian cornices are, as far as may be, suggestive; there is not the tenth of the work in them that there is in the Greek arrows, but, as far as that work will go, it has consistent intention; with the fewest possible incisions, and those of the easiest shape, they suggest the true image, of clusters of leaves, each leaf with its central depression from root to point, and that distinctly visible at almost any distance from the eye, and in almost any light.

§ XIX. Here, then, are two great new elements visible; energy and naturalism:—Life, with submission to the laws of God, and love of his works; this is Christianity, dealing with her classical models. Now look back to what I said in Chap. I. § xx. of this dealing of hers, and invention of the new Doric line; then to what is above stated (§ VIII.) respecting that new Doric, and the boughs of trees; and now to the evidence in the cutting of the leaves on the same Doric section, and see how the whole is beginning to come together.

§ XX. We said that something would come of these two cornices, *a* and *d*. In *e* and *f* we see that something *has* come of them: *e* is also from St. Mark's, and one of the earliest examples in Venice of the transition from the Byzantine to the Gothic cornice. It is already singularly developed; flowers have been added between the clusters of leaves, and the leaves themselves curled over: and observe the well-directed thought of the sculptor in this curling;—the old incisions are retained below, and their excessive rigidity is one of the proofs of the earliness of the cornice; but those incisions now stand for the *under* surface of the leaf; and behold, when it turns over, on the top of it you see true *ribs*. Look at the upper and under surface of a cabbage-leaf, and see what quick steps we are making.

§ XXI. The fifth example (*f*) was cut in 1347; it is from

the tomb of Marco Giustiniani, in the church of St. John and Paul, and it exhibits the character of the central Venetian Gothic fully developed. The lines are all now soft and undulatory, though elastic; the sharp incisions have become deeply-gathered folds; the hollow of the leaf is expressed completely beneath, and its edges are touched with light, and incised into several lobes, and their ribs delicately drawn above. (The flower between is only accidentally absent; it occurs in most cornices of the time.)

But in both these cornices the reader will notice that while the naturalism of the sculpture is steadily on the increase, the classical formalism is still retained. The leaves are accurately numbered, and sternly set in their places; they are leaves in office, and dare not stir nor wave. They have the shapes of leaves, but not the functions, "having the form of knowledge, but denying the power thereof." What is the meaning of this?

§ XII. Look back to paragraph xxxiii. of the first chapter, and you will see the meaning of it. These cornices are the Venetian Ecclesiastical Gothic; the Christian element struggling with the Formalism of the Papacy,—the Papacy being entirely heathen in all its principles. That officialism of the leaves and their ribs means Apostolic succession, and I don't know how much more, and is already preparing for the transition to old Heathenism again, and the Renaissance.*

§ XIII. Now look to the last cornice (*g*). That is Protestant-

* The Renaissance period being one of return to formalism on the one side, of utter licentiousness on the other, so that sometimes, as here, I have to declare its lifelessness, at other times (Chap. XXV., § XVII.) its lasciviousness. There is, of course, no contradiction in this: but the reader might well ask how I knew the change from the base 11 to the base 12, in Plate XII., to be one from temperance to luxury; and from the cornice *f* to the cornice *g*, in Plate XVI., to be one from formalism to vitality. I know it, both by certain internal evidences, on which I shall have to dwell at length hereafter, and by the context of the works of the time. But the outward signs might in both ornaments be the same, distinguishable only as signs of opposite tendencies by the event of both. The blush of shame cannot always be told from the blush of indignation.

ism,—a slight touch of Dissent, hardly amounting to schism, in those falling leaves, but true life in the whole of it. The forms all broken through, and sent heaven knows where, but the root held fast; and the strong sap in the branches; and, best of all, good fruit ripening and opening straight towards heaven, and in the face of it, even though some of the leaves lie in the dust.

Now, observe. The cornice *f* represents Heathenism and Papistry, animated by the mingling of Christianity and nature. The good in it, the life of it, the veracity and liberty of it, such as it has, are Protestantism in its heart; the rigidity and saplessness are the Romanism of it. It is the mind of Fra Angelico in the monk's dress,—Christianity before the Reformation. The cornice *g* has the Lombardic life element in its fulness, with only some color and shape of Classicalism mingled with it—the good of classicalism; as much method and Formalism as are consistent with life, and fitting for it: The continence within certain border lines, the unity at the root, the simplicity of the great profile,—all these are the healthy classical elements retained: the rest is reformation, new strength, and recovered liberty.

§ xxiv. There is one more point about it especially noticeable. The leaves are thoroughly natural in their general character, but they are of no particular species: and after being something like cabbage-leaves in the beginning, one of them suddenly becomes an ivy-leaf in the end. Now I don't know what to say of this. I know it, indeed, to be a classical character;—it is eminently characteristic of Southern work; and markedly distinctive of it from the Northern ornament, which would have been oak, or ivy, or apple, but not anything, nor two things in one. It is, I repeat, a clearly classical element; but whether a good or bad element, I am not sure;—whether it is the last trace of Centaurism and other monstrosity dying away; or whether it has a figurative purpose, legitimate in architecture (though never in painting), and has been rightly retained by the Christian sculptor, to express the working of that spirit which grafts one nature upon another, and discerns a law in its members warring against the law of its mind.

§ xxv. These, then, being the points most noticeable in the spirit both of the designs and the chiselling, we have now to return to the question proposed in § xiii., and observe the modifications of form of profile which resulted from the changing contours of the leafage ; for up to § xiii., we had, as usual, considered the possible conditions of form in the abstract ;—the modes in which they have been derived from each other in actual practice require to be followed in their turn. How the Greek Doric or Greek ogee cornices were invented is not easy to determine, and, fortunately, is little to our present purpose ; for the mediæval ogee cornices have an independent development of their own, from the first type of the concave cornice *a* in Plate XV.

§ xxvi. That cornice occurs, in the simplest work, perfectly pure, but in finished work it was quickly felt that there was a meagreness in its junction with the wall beneath it, where it was set as here at *a*, Fig. LXIII., which could only be conquered by concealing such junction in a bar of shadow. There were two ways of getting this bar : one by a

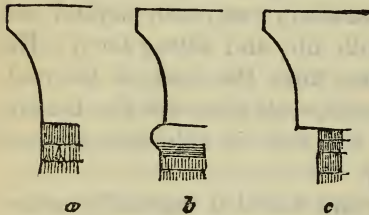

FIG. LXIII.

projecting roll at the foot of the cornice (*b*, Fig. LXIII.), the other by slipping the whole cornice a little forward (*c*, Fig. LXIII.). From these two methods arise two groups of cornices and capitals, which we shall pursue in succession.

§ xxvii. First group. With the roll at the base (*b*, Fig. LXIII.). The chain of its succession is represented from 1 to 6, in Plate XV. : 1 and 2 are the steps already gained, as in Fig. LXIII. ; and in them the profile of cornice used is *a* of Plate XV., or a refined condition of *b* of Fig. V., p. 75 above. Now, keeping the same refined profile, substitute the condition of it, *f* of Fig. V. (and there accounted for), above the roll here, and you have 3, Plate XV. This superadded abacus was instantly felt to be harsh in its projecting angle ; but you know what to do with an angle when it is harsh. Use your

simplest chamfer on it (*a* or *b*, Fig. LIII., page 261, above), but on the visible side only, and you have fig. 4, Plate XV. (the top stone being made deeper that you may have room to chamfer it). Now this fig. 4 is the profile of Lombardic and Venetian early capitals and cornices, by tens of thousands; and it continues into the late Venetian Gothic, with this only difference, that as time advances, the vertical line at the top of the original cornice begins to slope outwards, and through a series of years rises like the hazel wand in the hand of a diviner:—but how slowly! a stone dial which marches but 45 degrees in three centuries, and through the intermediate condition 5 arrives at 6, and so stays.

In tracing this chain I have kept all the profiles of the same height in order to make the comparison more easy; the depth chosen is about intermediate between that which is customary in cornices on the one hand, which are often a little shorter, and capitals on the other, which are often a little deeper.* And it is to be noted that the profiles 5 and 6 establish themselves in capitals chiefly, while 4 is retained in cornices to the latest times.

§ XXVIII. Second group (*c*, Fig. LXIII.). If the lower angle, which was quickly felt to be hard, be rounded off, we have the form *a*, Fig. LXIV. The front of the curved line is then decorated, as we have seen; and the termination of the decorated surface marked by an incision, as in an ordinary chamfer, as at *b* here. This I believe to have been the simple ori-

* The reader must always remember that a cornice, in becoming a capital, must, if not originally bold and deep, have depth added to its profile, in order to reach the just proportion of the lower member of the shaft head; and that therefore the small Greek egg cornices are utterly incapable of becoming capitals till they have totally changed their form and depth. The Renaissance architects, who never obtained hold of a right principle but they made it worse than a wrong one by misapplication, caught the idea of turning the cornice into a capital, but did not comprehend the necessity of the accompanying change of depth. Hence we have pilaster heads formed of small egg cornices, and that meanest of all mean heads of shafts, the coarse Roman Doric profile chopped into a small egg and arrow moulding, both which may be seen disfiguring half the buildings in London.

gin of most of the Venetian ogee cornices ; but they are farther complicated by the curves given to the leafage which flows over them. In the ordinary Greek cornices, and in *a* and *d* of Plate XVI., the decoration is *incised* from the outside profile, without any suggestion of an interior surface of a different contour. But in the leaf cornices which follow, the decoration is represented as *overlaid* on one of the early profiles, and has another outside contour of its own ; which is, indeed, the true profile of the cornice, but beneath which, more or less, the simpler profile is seen or suggested, which terminates all the incisions of the chisel. This under profile will often be found to be some condition of the type *a* or *b*, Fig. LXIV. ; and the leaf profile to be another ogee with its fullest curve up instead of down, lapping over the cornice

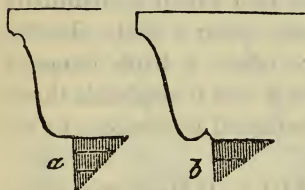

FIG. LXIV.

edge above, so that the entire profile might be considered as made up of two ogee curves laid, like packed herrings, head to tail. Figures 8 and 9 of Plate XV. exemplify this arrangement. Fig. 7 is a heavier contour, doubtless composed in the same manner,

but of which I had not marked the innermost profile, and which I have given here only to complete the series which, from 7 to 12 inclusive, exemplifies the gradual restriction of the leaf outline, from its boldest projection in the cornice to its most modest service in the capital. This change, however, is not one which indicates difference of age, but merely of office and position : the cornice 7 is from the tomb of the Doge Andrea Dandolo (1350) in St. Mark's, 8 from a canopy over a door of about the same period, 9 from the tomb of the Dogaressa Agnese Venier (1411), 10 from that of Pietro Cornaro (1361),* and 11 from that of Andrea Morosini (1347), all in the church of San Giov. and Paola, all there being cornice profiles ; and, finally, 12 from a capital of the Ducal Palace, of fourteenth century work.

* I have taken these dates roughly from Selvatico ; their absolute accuracy to within a year or two, is here of no importance.

§ XXIX. Now the reader will doubtless notice that in the three examples, 10 to 12, the leaf has a different contour from that of 7, 8, or 9. This difference is peculiarly significant. I have always desired that the reader should theoretically consider the capital as a concentration of the cornice; but in practice it often happens that the cornice is, on the contrary, an unrolled capital; and one of the richest early forms of the Byzantine cornice (not given in Plate XV., because its separate character and importance require examination apart) is nothing more than an unrolled continuation of the lower range of acanthus leaves on the Corinthian capital. From this cornice others appear to have been derived, like *e* in Plate XVI., in which the acanthus outline has become confused with that of the honeysuckle, and the rosette of the centre of the Corinthian capital introduced between them; and thus their forms approach more and more to those derived from the cornice itself. Now if the leaf has the contour of 10, 11, or 12, Plate XV., the profile is either actually of a capital, or of a cornice derived from a capital; while, if the leaf have the contour of 7 or 8, the profile is either actually of a cornice or of a capital derived from a cornice. Where the Byzantines use the acanthus, the Lombards use the Persepolitan water-leaf; but the connection of the cornices and capitals is exactly the same.

§ xxx. Thus far, however, we have considered the characters of profile which are common to the cornice and capital both. We have now to note what farther decorative features or peculiarities belong to the capital itself, or result from the theoretical gathering of the one into the other.

Look back to Fig. XXII., p. 117. The five types there given, represented the five different methods of concentration of the root of cornices, *a* of Fig. V. Now, as many profiles of cornices as were developed in Plate XV. from this cornice root, there represented by the dotted slope, so many may be applied to each of the five types in Fig. XXII.,—applied simply in *a* and *b*, but with farther modifications, necessitated by their truncations or spurs, in *c*, *d*, and *e*.

Then, these cornice profiles having been so applied in such

length and slope as is proper for capitals, the farther condition comes into effect described in Chapter IX. § xxiv., and any one of the cornices in Plate XV. may become the *abacus* of a capital formed out of any other, or out of itself. The infinity of forms thus resultant cannot, as may well be supposed, be exhibited or catalogued in the space at present permitted to us: but the reader, once master of the principle, will easily be able to investigate for himself the syntax of all examples that may occur to him, and I shall only here, as a kind of exercise, put before him a few of those which he will meet with most frequently in his Venetian inquiries, or which illustrate points, not hitherto touched upon, in the disposition of the abacus.

§ xxxi. In Plate XVII. the capital at the top, on the left hand, is the rudest possible gathering of the plain Christian Doric cornice, *d* of Plate XV. The shaft is octagonal, and the capital is not cut to fit it, but is square at the base; and the curve of its profile projects on two of its sides more than on the other two, so as to make the abacus oblong, in order to carry an oblong mass of brickwork, dividing one of the upper lights of a Lombard campanile at Milan. The awkward stretching of the brickwork, to do what the capital ought to have done, is very remarkable. There is here no second superimposed abacus.

§ xxxii. The figure on the right hand, at the top, shows the simple but perfect fulfilment of all the requirements in which the first example fails. The mass of brickwork to be carried is exactly the same in size and shape; but instead of being trusted to a single shaft, it has two of smaller area (compare Chap. VIII., § xiii.), and all the expansion necessary is now gracefully attained by their united capitals, hewn out of one stone. Take the section of these capitals through their angle, and nothing can be simpler or purer; it is composed of 2, in Plate XV., used for the capital itself, with *c* of Fig. LXIII. used for the abacus; the reader could hardly have a neater little bit of syntax for a first lesson. If the section be taken through the side of the bell, the capital profile is the root of cornices, *a* of Fig. V., with the added roll. This capital is somewhat remarkable in having its sides perfectly straight

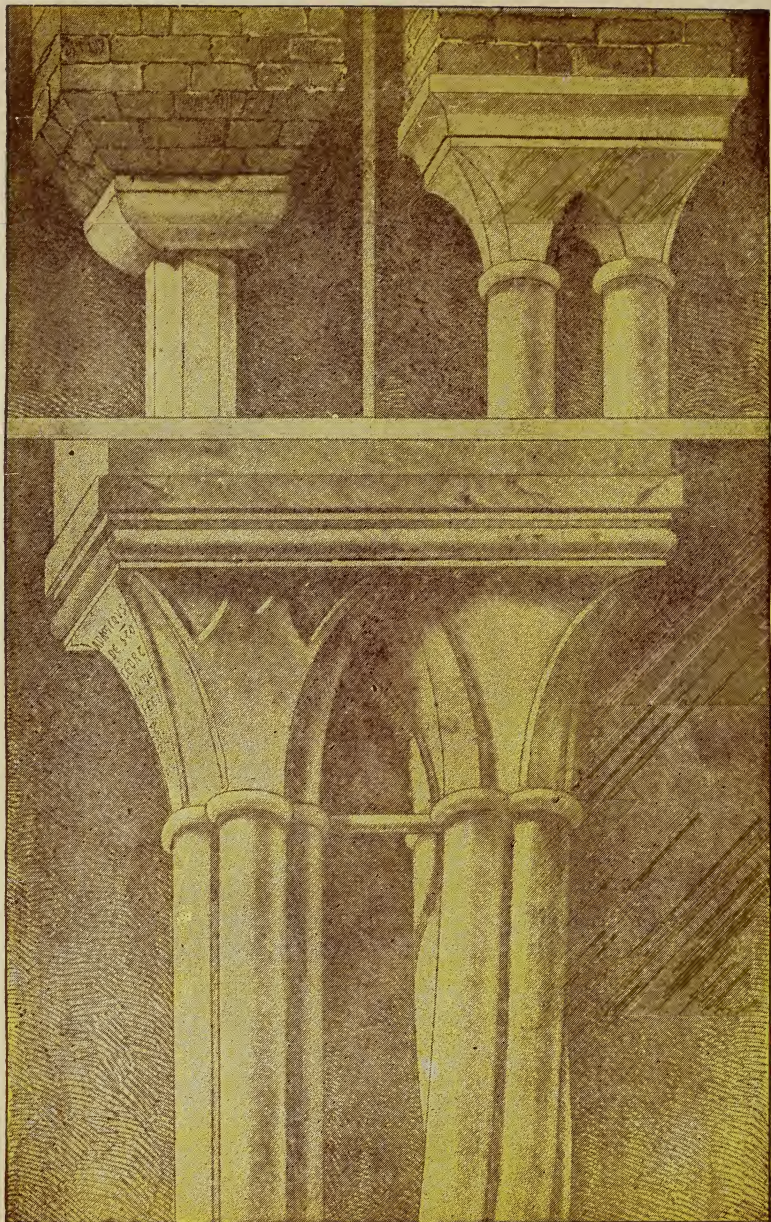

PLATE XVII.—CAPITALS. CONCAVE GROUP.

some slight curvature being usual on so bold a scale ; but it is all the better as a first example, the method of reduction being of order *d*, in Fig. XXII., p. 117, and with a concave cut, as in Fig. XXI., p. 116. These two capitals are from the cloister of the duomo of Verona.

§ xxxiii. The lowermost figure in Plate XVII. represents an exquisitely finished example of the same type, from St. Zeno of Verona. Above, at 2, in Plate II., the plan of the shafts was given, but I inadvertently reversed their position : in comparing that plan with Plate XVII., Plate II. must be held upside down. The capitals, with the band connecting them, are all cut out of one block ; their profile is an adaptation of 4 of Plate XV., with a plain headstone superimposed. This method of reduction is that of order *d* in Fig. XXII.,

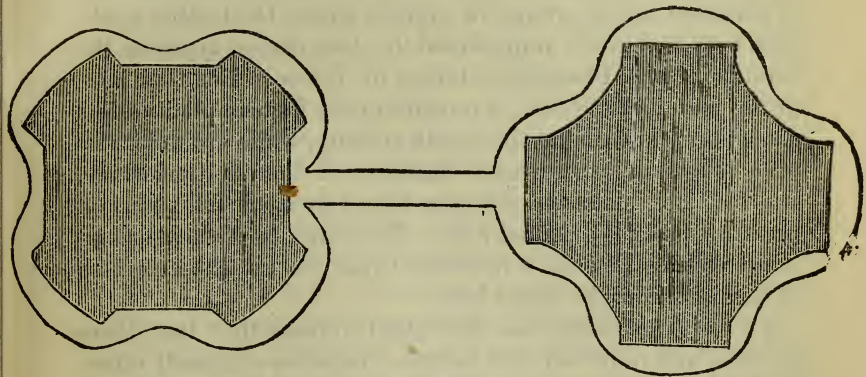

FIG. LXV.

but the peculiarity of treatment of their truncation is highly interesting. Fig. LXV. represents the plans of the capitals at the base, the shaded parts being the bells : the open line, the roll with its connecting band. The bell of the one, it will be seen, is the exact reverse of that of the other : the angle truncations are, in both, curved horizontally as well as uprightly ; but their curve is convex in the one, and in the other concave. Plate XVII. will show the effect of both, with the farther incisions, to the same depth, on the flank of the one with the concave truncation, which join with the rest of its

singularly bold and keen execution in giving the impression of its rather having been cloven into its form by the sweeps of a sword, than by the dull travail of a chisel. Its workman was proud of it, as well he might be: he has written his name upon its front (I would that more of his fellows had been as kindly vain), and the goodly stone proclaims for ever, ADAMINUS DE SANCTO GIORGIO ME FECIT.

§ XXXIV. The reader will easily understand that the gracefulness of this kind of truncation, as he sees it in Plate XVII., soon suggested the idea of reducing it to a vegetable outline, and laying four healing leaves, as it were, upon the wounds which the sword had made. These four leaves, on the truncations of the capital, correspond to the four leaves which we saw, in like manner, extend themselves over the spurs of the base, and, as they increase in delicacy of execution, form one of the most lovely groups of capitals which the Gothic workmen ever invented; represented by two perfect types in the capitals of the Piazzetta columns of Venice. But this pure group is an isolated one; it remains in the first simplicity of its conception far into the thirteenth century, while around it rise up a crowd of other forms, imitative of the old Corinthian, and in which other and younger leaves spring up in luxuriant growth among the primal four. The varieties of their grouping we shall enumerate hereafter: one general characteristic of them all must be noted here.

§ XXXV. The reader has been told repeatedly* that there are two, and only two, real orders of capitals, originally represented by the Corinthian and the Doric; and distinguished by the concave or convex contours of their bells, as shown by the dotted lines at *e*, Fig. V., p. 75. And hitherto, respecting the capital, we have been exclusively concerned with the methods in which these two families of simple contours have gathered themselves together, and obtained reconciliation to the abacus above, and the shaft below. But the last paragraph introduces us to the surface ornament disposed upon these, in the chiseling of which the characters described above, § XXVIII., which

* Chap. I. § XIX., Appendix 7: and Chap. VI. § V.

are but feebly marked in the cornice, boldly distinguished and divide the families of the capital.

§ xxxvi. Whatever the nature of the ornament be, it must clearly have relief of some kind, and must present projecting surfaces separated by incisions. But it is a very material question whether the contour, hitherto broadly considered as that of the entire bell, shall be that of the *outside* of the projecting and relieved ornaments, or of the *bottoms of the incisions* which divide them; whether, that is to say, we shall first cut out the bell of our capital quite smooth, and then cut farther into it, with incisions, which shall leave ornamental forms in relief, or whether, in originally cutting the contour of the bell, we shall leave projecting bits of stone, which we may afterwards work into the relieved ornament.

§ xxxvii. Now, look back to Fig. V., p. 75. Clearly, if to ornament the already hollowed profile, *b*, we cut deep incisions into it, we shall so far weaken it at the top, that it will nearly lose all its supporting power. Clearly, also, if to ornament the already bulging profile *c* we were to leave projecting pieces of stone outside of it, we should nearly destroy all its relation to the original sloping line X, and produce an unseemly and ponderous mass, hardly recognizable as a cornice profile. It is evident, on the other hand, that we can afford to cut into this profile without fear of destroying its strength, and that we can afford to leave projections outside of the other, without fear of destroying its lightness. Such is, accordingly, the natural disposition of the sculpture, and the two great families of capitals are therefore distinguished, not merely by their concave and convex contours, but by the ornamentation being left outside the bell of the one, and cut into the bell of the other; so that, in either case, the ornamental portions will fall *between the dotted lines* at *e*, Fig. V., and the pointed oval, or vesica piscis, which is traced by them, may be called the Limit of ornamentation.

§ xxxviii. Several distinctions in the quantity and style of the ornament must instantly follow from this great distinction in its position. First, in its quantity. For, observe: since in the Doric profile, *c* of Fig. V., the contour itself is to be com-

posed of the surface of the ornamentation, this ornamentation must be close and united enough to form, or at least suggest, a continuous surface ; it must, therefore, be rich in quantity and close in aggregation ; otherwise it will destroy the massy character of the profile it adorns, and approximate it to its opposite, the concave. On the other hand, the ornament left projecting from the concave, must be sparing enough, and dispersed enough, to allow the concave bell to be clearly seen beneath it ; otherwise it will choke up the concave profile, and approximate it to its opposite, the convex.

§ xxxix. And, secondly, in its style. For, clearly, as the sculptor of the concave profile must leave masses of rough stone prepared for his outer ornament, and cannot finish them at once, but must complete the cutting of the smooth bell beneath first, and then return to the projecting masses (for if he were to finish these latter first, they would assuredly, if delicate or sharp, be broken as he worked on ; since, I say, he must work in this foreseeing and predetermined method, he is sure to reduce the system of his ornaments to some definite symmetrical order before he begins) ; and the habit of conceiving beforehand all that he has to do, will probably render him not only more orderly in its arrangement, but more skilful and accurate in its execution, than if he could finish all as he worked on. On the other hand, the sculptor of the convex profile has its smooth surface laid before him, as a piece of paper on which he can sketch at his pleasure ; the incisions he makes in it are like touches of a dark pencil ; and he is at liberty to roam over the surface in perfect freedom, with light incisions or with deep ; finishing here, suggesting there, or perhaps in places leaving the surface altogether smooth. It is ten to one, therefore, but that, if he yield to the temptation, he becomes irregular in design, and rude in handling ; and we shall assuredly find the two families of capitals distinguished, the one by its symmetrical, thoroughly organised, and exquisitely executed ornament, the other by its rambling, confused, and rudely chiselled ornament : But, on the other hand, while we shall often have to admire the disciplined precision of the one, and as often to regret the irregular rudeness of the other,

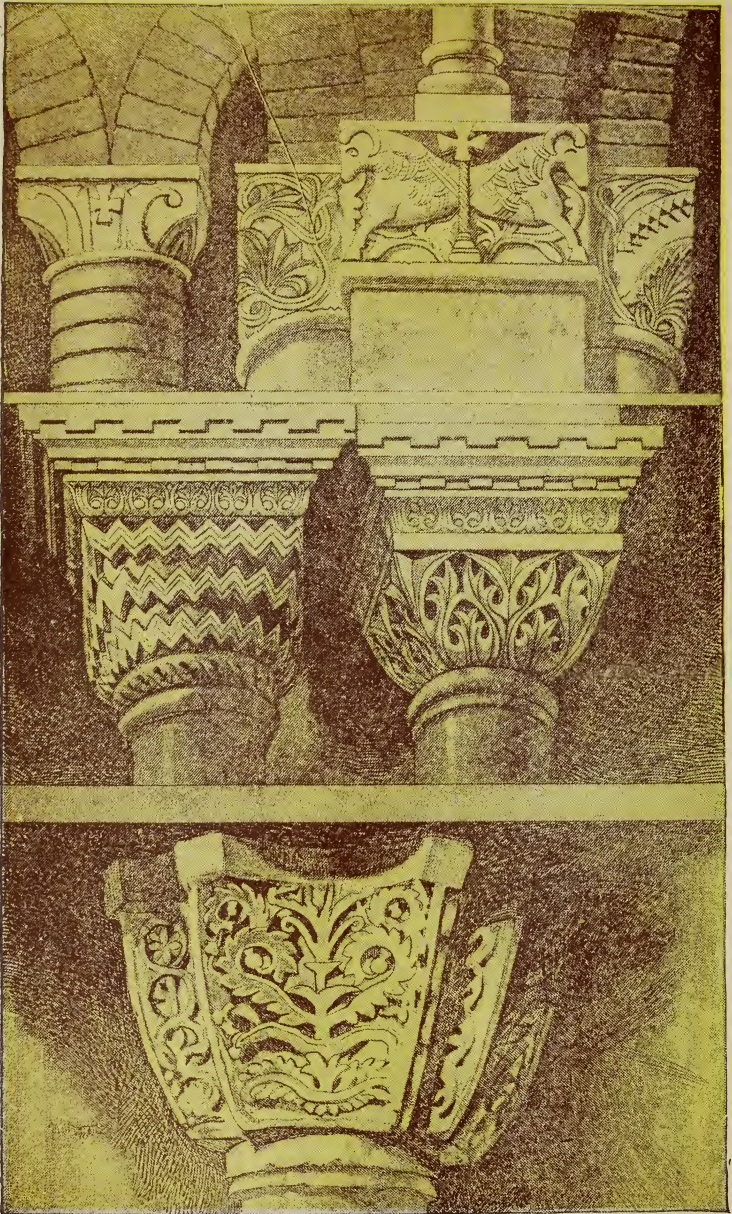

PLATE XVIII.—CAPITALS. CONVEX.

we shall not fail to find balancing qualities in both. The severity of the disciplinarian capital represses the power of the imagination; it gradually degenerates into Formalism; and the indolence which cannot escape from its stern demand of accurate workmanship, seeks refuge in copyism of established forms, and loses itself at last in lifeless mechanism. The license of the other, though often abused, permits full exercise to the imagination: the mind of the sculptor, unshackled by the niceties of chiselling, wanders over its orb'd field in endless fantasy; and, when generous as well as powerful, repays the liberty which has been granted to it with interest, by developing through the utmost wildness and fulness of its thoughts, an order as much more noble than the mechanical symmetry of the opponent school, as the domain which it regulates is vaster.

§ XL. And now the reader shall judge whether I had not reason to cast aside the so-called Five orders of the Renaissance architects, with their volutes and fillets, and to tell him that there were only two real orders, and that there could never be more.* For we now find that these two great and real orders are representative of the two great influences which must for ever divide the heart of man: the one of Lawful Discipline, with its perfection and order, but its danger of degeneration into Formalism; the other of Lawful Freedom, with its vigor and variety, but its danger of degeneracy into Licentiousness.

§ XLI. I shall not attempt to give any illustrations here of the most elaborate developments of either order; they will be better given on a larger scale: but the examples in Plate XVII. and XVIII. represent the two methods of ornament in their earliest appliance. The two lower capitals in Plate XVII. are a pure type of the concave school; the two in the centre of Plate XVIII., of the convex. At the top of Plate XVIII. are two Lombardic capitals; that on the left from Sta. Sofia at Padua, that on the right from the cortile of St. Ambrogio at Milan. They both have the concave angle truncation; but being of date prior to the time when the idea of the concave bell was developed, they are otherwise left square, and

* Chap. I., § XIX.

decorated with the surface ornament characteristic of the convex school. The relation of the designs to each other is interesting; the cross being prominent in the centre of each, but more richly relieved in that from St. Ambrogio. The two beneath are from the southern portico of St. Mark's; the shafts having been of different lengths, and neither, in all probability, originally intended for their present place, they have double abaci, of which the uppermost is the cornice running round the whole façade. The zigzagged capital is highly curious, and in its place very effective and beautiful; although one of the exceptions which it was above noticed that we should sometimes find to the law stated in § xv. above.

§ XLII. The lower capital, which is also of the true convex school, exhibits one of the conditions of the spurred type, *e* of Fig. XXII., respecting which one or two points must be noticed.

If we were to take up the plan of the simple spur, represented at *e* in Fig. XXII., p.

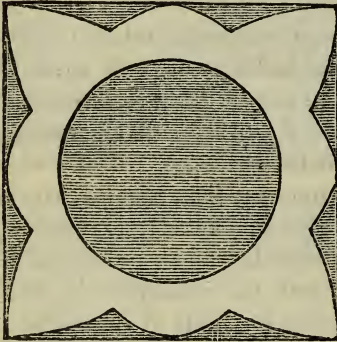

FIG. LXVI.

117, and treat it, with the salvia leaf, as we did the spur of the base, we should have for the head of our capital a plan like Fig. LXVI., which is actually that of one of the capitals of the Fondaco de' Turchi at Venice; with this only difference, that the intermediate curves between the spurs would have been circular: the reason they are not so, here, is that the decoration, instead of being confined to the

spur, is now spread over the whole mass, and contours are therefore given to the intermediate curves which fit them for this ornament; the inside shaded space being the head of the shaft, and the outer, the abacus. The reader has in Fig. LXVI. a characteristic type of the plans of the spurred capitals, generally preferred by the sculptors of the convex school, but treated with infinite variety, the spurs often being cut into

animal forms, or the incisions between them multiplied, for richer effect; and in our own Norman capital the type *c* of Fig. XXII. is variously subdivided by incisions on its slope, approximating in general effect to many conditions of the real spurred type, *e*, but totally differing from them in principle.

§ XLIII. The treatment of the spur in the concave school is far more complicated, being borrowed in nearly every case from the original Corinthian. Its plan may be generally represented by Fig. LXVII. The spur itself is carved into



Fig. LXVII.

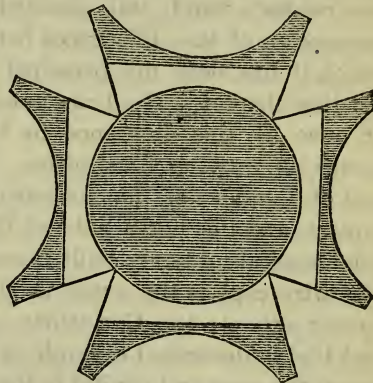

Fig. LXVIII.

a curling tendril or concave leaf, which supports the projecting angle of a four-sided abacus, whose hollow sides fall back behind the bell, and have generally a rosette or other ornament in their centres. The mediæval architects often put another square abacus above all, as represented by the shaded portion of Fig. LXVII., and some massy conditions of this form, elaborately ornamented, are very beautiful; but it is apt to become rigid and effeminate, as assuredly it is in the original Corinthian, which is thoroughly mean and meagre in its upper tendrils and abacus.

§ XLIV. The lowest capital in Plate XVIII. is from St. Mark's, and singular in having double spurs; it is therefore to be compared with the doubly spurred base, also from St. Mark's, in Plate XI. In other respects it is a good example of the union of breadth of mass with subtlety of curvature,

which characterises nearly all the spurred capitals of the convex school. Its plan is given in Fig. LXVIII. : the inner shaded circle is the head of the shaft ; the white cross, the bottom of the capital, which expands itself into the external shaded portions at the top. Each spur, thus formed, is cut like a ship's bow, with the Doric profile ; the surfaces so obtained are then charged with arborescent ornament.

§ XLV. I shall not here farther exemplify the conditions of the treatment of the spur, because I am afraid of confusing the reader's mind, and diminishing the distinctness of his conception of the differences between the two great orders, which it has been my principal object to develope throughout this chapter. If all my readers lived in London, I could at once fix this difference in their minds by a simple, yet somewhat curious illustration. In many parts of the west end of London, as, for instance, at the corners of Belgrave Square, and the north side of Grosvenor Square, the Corinthian capitals of newly-built houses are put into cages of wire. The wire cage is the exact form of the typical capital of the convex school ; the Corinthian capital, within, is a finished and highly decorated example of the concave. The space between the cage and capital is the limit of ornamentation.

§ XLVI. Those of my readers, however, to whom this illustration is inaccessible, must be content with the two profiles, 13 and 14, on Plate XV. If they will glance along the line of sections from 1 to 6, they will see that the profile 13 is their final development, with a superadded cornice for its abacus. It is taken from a capital in a very important ruin of a palace, near the Rialto of Venice, and hereafter to be described ; the projection, outside of its principal curve, is the profile of its *superadded* leaf ornamentation ; it may be taken as one of the simplest, yet a perfect type of the concave group.

§ XLVII. The profile 14 is that of the capital of the main shaft of the northern portico of St. Mark's, the most finished example I ever met with of the convex family, to which, in spite of the central inward bend of its profile, it is marked as distinctly belonging, by the bold convex curve at its root, springing from the shaft in the line of the Christian Doric

cornice, and exactly reversing the structure of the other profile, which rises from the shaft, like a palm leaf from its stem. Farther, in the profile 13, the innermost line is that of the bell; but in the profile 14, the outermost line is that of the bell, and the inner line is the limit of the incisions of the chisel, in undercutting a reticulated veil of ornament, surrounding a flower like a lily; most ingeniously, and, I hope, justly, conjectured by the Marchese Selvatico to have been intended for an imitation of the capitals of the temple of Solomon, which Hiram made, with ‘nets of checker work, and wreaths of chain work for the chapiters that were on the top of the pillars . . . and the chapiters that were upon the top of the pillars were of lily work in the porch.’ (1 Kings, vii. 17, 19.)

§ XLVIII. On this exquisite capital there is imposed an abacus of the profile with which we began our investigation long ago, the profile *a* of Fig. V. This abacus is formed by the cornice already given, *a*, of Plate XVI.: and therefore we have, in this lovely Venetian capital, the summary of the results of our investigation, from its beginning to its close: the type of the first cornice; the decoration of it, in its emergence from the classical models; the gathering into the capital; the superimposition of the secondary cornice, and the refinement of the bell of the capital by triple curvature in the two limits of chiselling. I cannot express the exquisite refinements of the curves on the small scale of Plate XV.; I will give them more accurately in a larger engraving; but the scale on which they are here given will not prevent the reader from perceiving, and let him note it thoughtfully, that the outer curve of the noble capital is the one which was our first example of associated curves; that I have had no need, throughout the whole of our inquiry, to refer to any other ornamental line than the three which I at first chose, the simplest of those which Nature set by chance before me; and that this lily, of the delicate Venetian marble, has but been wrought, by the highest human art, into the same line which the clouds disclose, when they break from the rough rocks of the flank of the Matterhorn.

CHAPTER XXVIII.

THE ARCHIVOLT AND APERTURE.

§ I. If the windows and doors of some of our best northern Gothic buildings were built up, and the ornament of their archivolt concealed, there would often remain little but masses of dead wall and unsightly buttress; the whole vitality of the building consisting in the graceful proportions or rich mouldings of its apertures. It is not so in the south, where, frequently, the aperture is a mere dark spot on the variegated wall; but there the column, with its horizontal or curved architrave, assumes an importance of another kind, equally dependent upon the methods of lintel and archivolt decoration. These, though in their richness of minor variety they defy all exemplification, may be very broadly generalized.

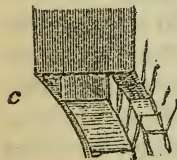
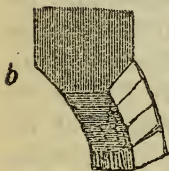
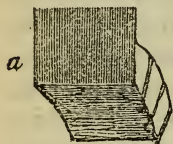
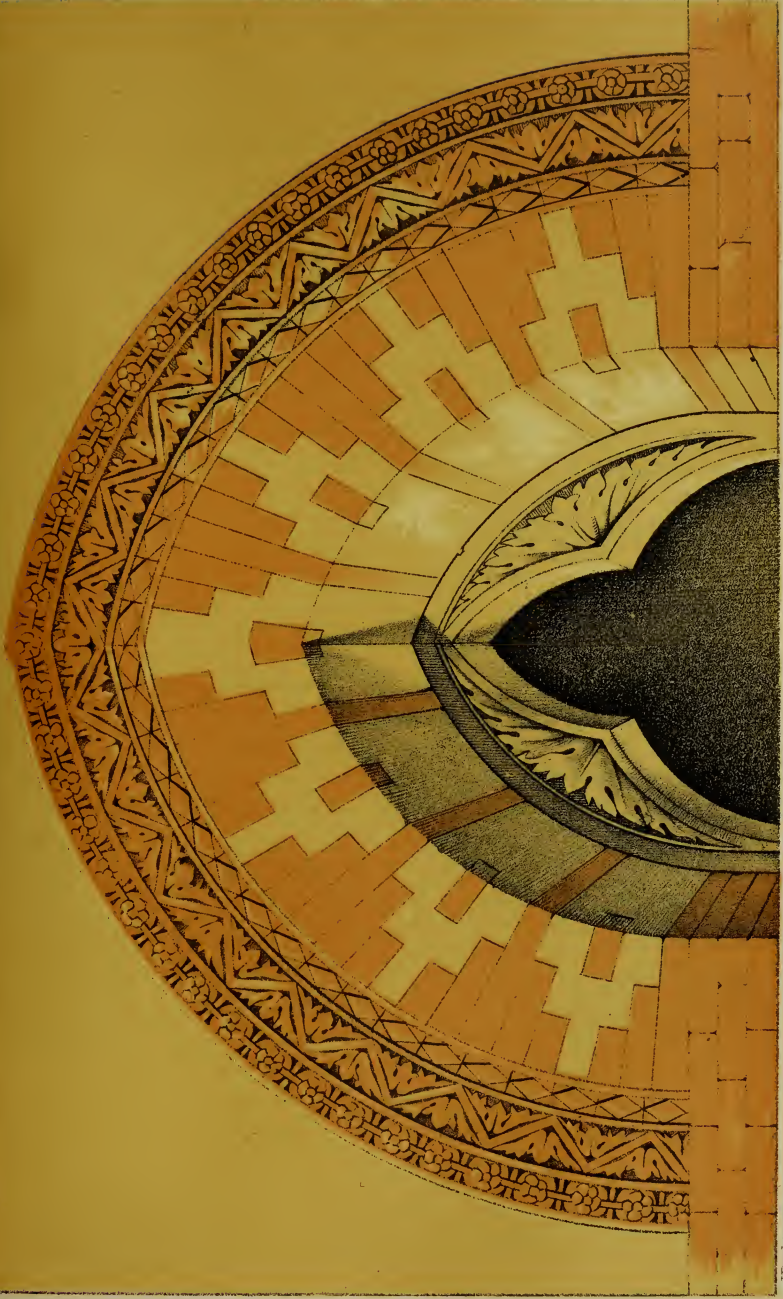

FIG. LXIX.

Of the mere lintel, indeed, there is no specific decoration, nor can be; it has no organism to direct its ornament, and therefore may receive any kind and degree of ornament, according to its position. In a Greek temple, it has meagre horizontal lines; in a Romanesque church, it becomes a row of upright niches, with an apostle in each; and may become anything else at the architect's will. But the arch head has a natural organism, which separates its ornament into distinct families, broadly definable.

§ II. In speaking of the arch-line and arch masonry, we considered the arch to be cut straight through the wall; so that, if half built, it would have the appearance at *a*, Fig. LXIX. But in the chapter on Form of Apertures, we found that the side of the arch, or jamb of the aperture, might often require to be bevelled, so as to give the section *b*, Fig. LXIX. It is easily



T. S. Boys

Archivolt Decoration.

J. Ruskin.

conceivable that when two ranges of voussoirs were used, one over another, it would be easier to leave those beneath, of a smaller diameter, than to bevel them to accurate junction with those outside. Whether influenced by this facility, or by decorative instinct, the early northern builders often substitute for the bevel the third condition, *c*, of Fig. LXIX.; so that, of the three forms in that figure, *a* belongs principally to the south, *c* to the north, and *b* indifferently to both.

§ III. If the arch in the northern building be very deep, its depth will probably be attained by a succession of steps, like that in *c*; and the richest results of northern archivolt decoration are entirely based on the aggregation of the ornament of these several steps; while those of the south are only the complete finish and perfection of the ornament of one. In this ornament of the single arch, the points for general note are very few.

§ IV. It was, in the first instance, derived from the classical architrave,* and the early Romanesque arches are nothing but such an architrave, bent round. The horizontal lines of the latter become semicircular, but their importance and value remain exactly the same; their continuity is preserved across all the voussoirs, and the joints and functions of the latter are studiously concealed. As the builders get accustomed to the arch, and love it better, they cease to be ashamed of its structure: the voussoirs begin to show themselves confidently, and fight for precedence with the architrave lines; and there is an entanglement of the two structures, in consequence, like the circular and radiating lines of a cobweb, until at last the architrave lines get worsted, and driven away outside of the voussoirs; being permitted to stay at all only on condition of their dressing themselves in mediæval costume, as in the plate opposite.

§ V. In other cases, however, before the entire discomfiture of the architrave, a treaty of peace is signed between the adverse parties on these terms: That the architrave shall en-

* The architrave is properly the horizontal piece of stone laid across the tops of the pillars in Greek buildings, and commonly marked with horizontal lines, obtained by slight projections of its surface, while it is protected above in the richer orders, by a small cornice.

tirely dismiss its inner three meagre lines, and leave the space of them to the voussoirs, to display themselves after their manner ; but that, in return for this concession, the architrave shall have leave to expand the small cornice which usually terminates it (the reader had better look at the original form in that of the Erechtheum, in the middle of the Elgin room of the British Museum) into bolder prominence, and even to put brackets under it, as if it were a roof cornice, and thus mark with a bold shadow the terminal line of the voussoirs. This condition is seen in the arch from St. Pietro of Pistoja, Plate XIII., above.

§ VI. If the Gothic spirit of the building be thoroughly determined, and victorious, the architrave cornice is compelled to relinquish its classical form, and take the profile of a Gothic cornice or dripstone ; while, in other cases, as in much of the Gothic of Verona, it is forced to disappear altogether. But the voussoirs then concede, on the other hand, so much of their dignity as to receive a running ornament of foliage or animals, like a classical frieze, and continuous round the arch. In fact, the contest between the adversaries may be seen running through all the early architecture of Italy : success inclining sometimes to the one, sometimes to the other, and various kinds of truce or reconciliation being effected between them : sometimes merely formal, sometimes honest and affectionate, but with no regular succession in time. The greatest victory of the voussoir is to annihilate the cornice, and receive an ornament of its own outline, and entirely limited by its own joints : and yet this may be seen in the very early apse of Murano.

§ VII. The most usual condition, however, is that unity of the two members above described, § v., and which may be generally represented by the archivolt section *a*, Fig. LXX. ; and from this descend a family of Gothic archivolts of the highest importance. For the cornice, thus attached to the arch, suffers exactly the same changes as the level cornice, or capital ; receives, in due time, its elaborate ogee profile and leaf ornaments, like Fig. 8 or 9 of Plate XV. ; and, when the shaft loses its shape, and is lost in the later Gothic jamb, the archivolt has influence enough to introduce this ogee profile

in the jamb also, through the banded impost: and we immediately find ourselves involved in deep successions of ogee mouldings in sides of doors and windows, which never would have been thought of, but for the obstinate resistance of the classical architrave to the attempts of the voussoir at its degradation or banishment.

§ VIII. This, then, will be the first great head under which we shall in future find it convenient to arrange a large number of archivolt decorations. It is the distinctively Southern and Byzantine form, and typically represented by the section *a*, of Fig. LXX.; and it is susceptible of almost every species of surface ornament, respecting which only this general law may be asserted: that, while the outside or vertical surface may properly be decorated, and yet the soffit or under surface left plain, the soffit is never to be decorated, and the outer surface left plain. Much beautiful sculpture is, in the best Byzantine buildings, half lost by being put under soffits; but the eye is led to discover it, and even to demand it, by the rich chasing of the outside of the voussoirs. It would have been an hypocrisy to carve them externally only. But there is not the smallest excuse for carving the soffit, and not the outside; for, in that case, we approach the building under the idea of its being perfectly plain; we do not look for the soffit decoration, and, of course, do not see it: or, if we do, it is merely to regret that it should not be in a better place. In the Renaissance architects, it may, perhaps, for once, be considered a merit, that they put their bad decorations systematically in the places where we should least expect it, and can seldomest see it:—Approaching the Scuola di San Rocco, you probably will regret the extreme plainness and barrenness of the window traceries; but, if you will go very close to the wall beneath the windows, you may, on sunny days, discover a quantity of panel decorations which the ingenious architect has concealed under the soffits.

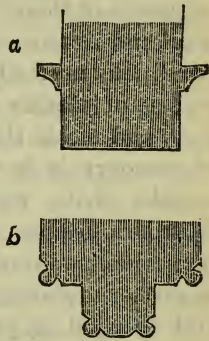

FIG. LXX.

The custom of decorating the arch soffit with panelling is a Roman application of the Greek roof ornament, which, whatever its intrinsic merit (compare Chap. XXIX. § iv.), may rationally be applied to waggon vaults, as of St. Peter's, and to arch soffits under which one walks. But the Renaissance architects had not wit enough to reflect that people usually do not walk through windows.

§ ix. So far, then, of the Southern archivolt: In Fig. LXIX., above, it will be remembered that *c* represents the simplest form of the Northern. In the farther development of this, which we have next to consider, the voussoirs, in consequence of their own negligence or over-confidence, sustain a total and irrecoverable defeat. That archivolt is in its earliest conditions perfectly pure and undecorated,—the simplest and rudest of Gothic forms. Necessarily, when it falls on the pier, and meets that of the opposite arch, the entire section of masonry is in the shape of a cross, and is carried by the crosslet shaft, which we above stated to be distinctive of Northern design. I am more at a loss to account for the sudden and fixed development of this type of archivolt than for any other architectural transition with which I am acquainted. But there it is, pure and firmly established, as early as the building of St. Michele of Pavia; and we have thenceforward only to observe what comes of it.

§ x. We find it first, as I said, perfectly barren; cornice and architrave altogether ignored, the existence of such things practically denied, and a plain, deep-cut recess with a single mighty shadow occupying their place. The voussoirs, thinking their great adversary utterly defeated, are at no trouble to show themselves; visible enough in both the upper and under archivolts, they are content to wait the time when, as might have been hoped, they should receive a new decoration peculiar to themselves.

§ xi. In this state of paralysis, or expectation, their flank is turned by an insidious chamfer. The edges of the two great blank archivolts are felt to be painfully conspicuous; all the four are at once beaded or chamfered, as at *b*, Fig. LXX.; a rich group of deep lines, running concentrically with the arch,

is the result on the instant, and the fate of the voussoirs is sealed. They surrender at once without a struggle, and unconditionally; the chamfers deepen and multiply themselves, cover the soffit, ally themselves with other forms resulting from grouped shafts or traceries, and settle into the inextricable richness of the fully developed Gothic jamb and arch; farther complicated in the end by the addition of niches to their recesses, as above described.

§ XII. The voussoirs, in despair, go over to the classical camp, in hope of receiving some help or tolerance from their former enemies. They receive it indeed: but as traitors should, to their own eternal dishonor. They are sharply chiselled at the joints, or rusticated, or cut into masks and satyrs' heads, and so set forth and pilloried in the various detestable forms of which the simplest is given above in Plate XIII. (on the left): and others may be seen in nearly every large building in London, more especially in the bridges; and, as if in pure spite at the treatment they had received from the archivolt, they are now not content with vigorously showing their lateral joints, but shape themselves into right-angled steps at their heads, cutting to pieces their limiting line, which otherwise would have had sympathy with that of the arch, and fitting themselves to their new friend, the Renaissance Ruled Copy-book wall. It had been better they had died ten times over, in their own ancient cause, than thus prolonged their existence.

§ XIII. We bid them farewell in their dishonor, to return to our victorious chamfer. It had not, we said, obtained so easy a conquest, unless by the help of certain forms of the grouped shaft. The chamfer was quite enough to decorate the archivolt, if there were no more than two; but if, as above noticed in § III., the archivolt was very deep, and composed of a succession of such steps, the multitude of chamferings were felt to be weak and insipid, and instead of dealing with the outside edges of the archivolt, the group was softened by introducing solid shafts in their dark inner angles. This, the manliest and best condition of the early northern jamb and archivolt, is represented in section at fig. 12 of Plate

II. ; and its simplest aspect in Plate V., from the Broletto of Como,—an interesting example, because there the voussoirs being in the midst of their above-described southern contest with the architrave, were better prepared for the flank attack upon them by the shaft and chamfer, and make a noble resistance, with the help of color, in which even the shaft itself gets slightly worsted, and cut across in several places, like General Zach's column at Marengo.

§ XIV. The shaft, however, rapidly rallies, and brings up its own peculiar decorations to its aid ; and the intermediate archivolt receives running or panelled ornaments, also, until we reach the exquisitely rich conditions of our own Norman archivolts, and of the parallel Lombardic designs, such as the entrance of the Duomo, and of San Fermo, at Verona. This change, however, occupies little time, and takes place principally in doorways, owing to the greater thickness of wall, and depth of archivolt ; so that we find the rich shafted succession of ornament, in the doorway and window aperture, associated with the earliest and rudest double archivolt, in the nave arches, at St. Michele of Pavia. The nave arches, therefore, are most usually treated by the chamfer, and the voussoirs are there defeated much sooner than by the shafted arrangements, which they resist, as we saw, in the south by color ; and even in the north, though forced out of their own shape, they take that of birds' or monsters' heads, which for some time peck and pinch the rolls of the archivolt to their hearts' content ; while the Norman zigzag ornament allies itself with them, each zigzag often restraining itself amicably between the joints of each voussoir in the ruder work, and even in the highly finished arches, distinctly presenting a concentric or sunlike arrangement of lines ; so much so, as to prompt the conjecture, above stated, Chap. XX. § xxvi., that all such ornaments were intended to be typical of light issuing from the orb of the arch. I doubt the intention, but acknowledge the resemblance ; which perhaps goes far to account for the never-failing delightfulness of this zigzag decoration. The diminution of the zigzag, as it gradually shares the defeat of the voussoir, and is at last overwhelmed by the complicated,

railroad-like fluency of the later Gothic mouldings, is to me one of the saddest sights in the drama of architecture.

§ xv. One farther circumstance is deserving of especial note in Plate V., the greater depth of the voussoirs at the top of the arch. This has been above alluded to as a feature of good construction, Chap. XI., § III. ; it is to be noted now as one still more valuable in decoration : for when we arrive at the deep succession of concentric archivolt, with which northern portals, and many of the associated windows, are headed, we immediately find a difficulty in reconciling the outer curve with the inner. If, as is sometimes the case, the width of the group of archivolt be twice or three times that of the inner aperture, the inner arch may be distinctly pointed, and the outer one, if drawn with concentric arcs, approximate very nearly to a round arch. This is actually the case in the later Gothic of Verona ; the outer line of the archivolt having a hardly perceptible point, and every inner arch of course forming the point more distinctly, till the innermost becomes a lancet. By far the nobler method, however, is that of the pure early Italian Gothic ; to make every outer arch a *magnified fac-simile* of the innermost one, every arc including the same number of degrees, but degrees of a larger circle. The result is the condition represented in Plate V., often found in far bolder development ; exquisitely springy and elastic in its expression, and entirely free from the heaviness and monotony of the deep northern archivolt.

§ xvi. We have not spoken of the intermediate form, *b*, of Fig. LXIX. (which its convenience for admission of light has rendered common in nearly all architectures), because it has no transitions peculiar to itself : in the north it sometimes shares the fate of the outer architrave, and is channelled into longitudinal mouldings ; sometimes remains smooth and massy, as in military architecture, or in the simpler forms of domestic and ecclesiastical. In Italy it receives surface decoration like the architrave, but has, perhaps, something of peculiar expression in being placed between the tracery of the window within, and its shafts and tabernacle work without, as in the Duomo of Florence : in this position it is always kept smooth in sur-

face, and inlaid (or painted) with delicate arabesques ; while the tracery and the tabernacle work are richly sculptured. The example of its treatment by colored voussoirs, given in Plate XIX., may be useful to the reader as a kind of central expression of the aperture decoration of the pure Italian Gothic ;—aperture decoration proper ; applying no shaft work to the jambs, but leaving the bevelled opening unenriched ; using on the outer archivolt the voussoirs and concentric architrave in reconciliation (the latter having, however, some connection with the Norman zigzag) ; and beneath them, the pure Italian two-pieced and mid-cusped arch, with rich cusp decoration. It is a Veronese arch, probably of the thirteenth century, and finished with extreme care ; the red portions are all in brick, delicately cast : and the most remarkable feature of the whole is the small piece of brick inlaid on the angle of each stone voussoir, with a most just feeling, which every artist will at once understand, that the color ought not to be let go all at once.

§ xvii. We have traced the various conditions of treatment in the archivolt alone ; but, except in what has been said of the peculiar expression of the voussoirs, we might throughout have spoken in the same terms of the jamb. Even a parallel to the expression of the voussoir may be found in the Lombardic and Norman divisions of the shafts, by zigzags and other transverse ornamentation, which in the end are all swept away by the canaliculated mouldings. Then, in the recesses of these and of the archivolts alike, the niche and statue decoration develops itself ; and the vaulted and cavernous apertures are covered with incrustations of fretwork, and with every various application of foliage to their fantastic mouldings.

§ xviii. I have kept the inquiry into the proper ornament of the archivolt wholly free from all confusion with the questions of beauty in tracery ; for, in fact, all tracery is a mere multiplication and entanglement of small archivolts, and its cusp ornament is a minor condition of that proper to the spandril. It does not reach its completely defined form until the jamb and archivolt have been divided into longitudinal mouldings ; and then the tracery is formed by the innermost group

of the shafts or fillets, bent into whatever forms or foliations the designer may choose ; but this with a delicacy of adaptation which I rather choose to illustrate by particular examples, of which we shall meet with many in the course of our inquiry, than to delay the reader by specifying here. As for the conditions of beauty in the disposition of the tracery bars, I see no hope of dealing with the subject fairly but by devoting, if I can find time, a separate essay to it—which, in itself, need not be long, but would involve, before it could be completed, the examination of the whole mass of materials lately collected by the indefatigable industry of the English architects who have devoted their special attention to this subject, and which are of the highest value as illustrating the chronological succession or mechanical structure of tracery, but which, in most cases, touch on their æsthetic merits incidentally only. Of works of this kind, by far the best I have met with is Mr. Edmund Sharpe's, on Decorated Windows, which seems to me, as far as a cursory glance can enable me to judge, to exhaust the subject as respects English Gothic ; and which may be recommended to the readers who are interested of the subject, as containing a clear and masterly enunciation of the general principles by which the design of tracery has been regulated, from its first development to its final degradation.

CHAPTER XXIX.

THE ROOF.

§ I. THE modes of decoration hitherto considered, have been common to the exteriors and interiors of all noble buildings ; and we have taken no notice of the various kinds of ornament which require protection from weather, and are necessarily confined to interior work. But in the case of the roof, the exterior and interior treatments become, as we saw in construction, so also in decoration, separated by broad and bold distinctions. One side of a wall is, in most cases, the same as another, and if its structure be concealed, it is mostly

on the inside ; but, in the roof, the anatomical structure, out of which decoration should naturally spring, is visible, if at all, in the interior only : so that the subject of internal ornament becomes both wide and important, and that of external, comparatively subordinate.

§ II. Now, so long as we were concerned principally with the outside of buildings, we might with safety leave expressional character out of the question for the time, because it is not to be expected that all persons who pass the building, or see it from a distance, shall be in the temper which the building is properly intended to induce ; so that ornaments somewhat at variance with this temper may often be employed externally without painful effect. But these ornaments would be inadmissible in the interior, for those who enter will for the most part either be in the proper temper which the building requires, or desirous of acquiring it. (The distinction is not rigidly observed by the mediæval builders, and grotesques, or profane subjects, occur in the interior of churches, in bosses, crockets, capitals, brackets, and such other portions of minor ornament : but we do not find the interior wall covered with hunting and battle pieces, as often the Lombardic exteriors.) And thus the interior expression of the roof or ceiling becomes necessarily so various, and the kind and degree of fitting decoration so dependent upon particular circumstances, that it is nearly impossible to classify its methods, or limit its application.

§ III. I have little, therefore, to say here, and that touching rather the omission than the selection of decoration, as far as regards interior roofing. Whether of timber or stone, roofs are necessarily divided into surfaces, and ribs or beams ;—surfaces, flat or carved ; ribs, traversing these in the directions where main strength is required ; or beams, filling the hollow of the dark gable with the intricate roof-tree, or supporting the flat ceiling. Wherever the ribs and beams are simply and unaffectedly arranged, there is no difficulty about decoration ; the beams may be carved, the ribs moulded, and the eye is satisfied at once ; but when the vaulting is unribbed, as in plain waggon vaults and much excellent early Gothic, or

when the ceiling is flat, it becomes a difficult question how far their services may receive ornamentation independent of their structure. I have never myself seen a flat ceiling satisfactorily decorated, except by painting: there is much good and fanciful panelling in old English domestic architecture, but it always is in some degree meaningless and mean. The flat ceilings of Venice, as in the Scuola di San Rocco and Ducal Palace, have in their vast panellings some of the noblest paintings (on stretched canvas) which the world possesses: and this is all very well for the ceiling; but one would rather have the painting in a better place, especially when the rain soaks through its canvas, as I have seen it doing through many a noble Tintoret. On the whole, flat ceilings are as much to be avoided as possible; and, when necessary, perhaps a panelled ornamentation with rich colored patterns is the most satisfying, and loses least of valuable labor. But I leave the question to the reader's thought, being myself exceedingly undecided respecting it: except only touching one point—that a blank ceiling is not to be redeemed by a decorated ventilator.

§ iv. I have a more confirmed opinion, however, respecting the decoration of curved surfaces. The majesty of a roof is never, I think, so great, as when the eye can pass undisturbed over the course of all its curvatures, and trace the dying of the shadows along its smooth and sweeping vaults. And I would rather, myself, have a plain ridged Gothic vault, with all its rough stones visible, to keep the sleet and wind out of a cathedral aisle, than all the fanning and pendanting and foliation that ever bewildered Tudor wight. But mosaic or fresco may of course be used as far as we can afford or obtain them; for these do not break the curvature. Perhaps the most solemn roofs in the world are the apse conchas of the Romanesque basilicas, with their golden ground and severe figures. Exactly opposed to these are the decorations which disturb the serenity of the curve without giving it interest, like the vulgar panelling of St. Peter's and the Pantheon; both, I think, in the last degree detestable.

§ v. As roofs internally may be divided into surfaces and

ribs, externally they may be divided into surfaces, and points, or ridges ; these latter often receiving very bold and distinctive ornament. The outside surface is of small importance in central Europe, being almost universally low in slope, and tiled throughout Spain, South France, and North Italy : of still less importance where it is flat, as a terrace ; as often in South Italy and the East, mingled with low domes : but the larger Eastern and Arabian domes become elaborate in ornamentation : I cannot speak of them with confidence ; to the mind of an inhabitant of the north, a roof is a guard against wild weather ; not a surface which is forever to bask in serene heat, and gleam across deserts like a rising moon. I can only say, that I have never seen any drawing of a richly decorated Eastern dome that made me desire to see the original.

§ vi. Our own northern roof decoration is necessarily simple. Colored tiles are used in some cases with quaint effect ; but I believe the dignity of the building is always greater when the roof is kept in an undisturbed mass, opposing itself to the variegation and richness of the walls. The Italian round tile is itself decoration enough, a deep and rich fluting, which all artists delight in ; this, however, is fitted exclusively for low pitch of roofs. On steep domestic roofs, there is no ornament better than may be obtained by merely rounding, or cutting to an angle, the lower extremities of the flat tiles or shingles, as in Switzerland : thus the whole surface is covered with an appearance of scales, a fish-like defence against water, at once perfectly simple, natural, and effective at any distance ; and the best decoration of sloping stone roofs, as of spires, is a mere copy of this scale armor ; it enriches every one of the spires and pinnacles of the cathedral of Coutances, and of many Norman and early Gothic buildings. Roofs covered or edged with lead have often patterns designed upon the lead, gilded and relieved with some dark color, as on the house of Jaques Cœur at Bourges ; and I imagine the effect of this must have been singularly delicate and beautiful, but only traces of it now remain. The northern roofs, however, generally stand in little need of surface decoration, the eye being drawn to the fantastic ranges of

their dormer windows, and to the finials and fringes on their points and ridges.

§ VII. Whether dormer windows are legitimately to be classed as decorative features, seems to me to admit of doubt. The northern spire system is evidently a mere elevation and exaggeration of the domestic turret with its look-out windows, and one can hardly part with the grotesque lines of the projections, though nobody is to be expected to live in the spire: but, at all events, such windows are never to be allowed in places visibly inaccessible, or on less than a natural and serviceable scale.

§ VIII. Under the general head of roof-ridge and point decoration, we may include, as above noted, the entire race of fringes, finials, and crockets. As there is no use in any of these things, and as they are visible additions and parasitical portions of the structure, more caution is required in their use than in any other features of ornament, and the architect and spectator must both be in felicitous humor before they can be well designed or thoroughly enjoyed. They are generally most admirable where the grotesque Northern spirit has most power; and I think there is almost always a certain spirit of playfulness in them, adverse to the grandest architectural effects, or at least to be kept in severe subordination to the serener character of the prevalent lines. But as they are opposed to the seriousness of majesty on the one hand, so they are to the weight of dulness on the other; and I know not any features which make the contrast between continental domestic architecture, and our own, more humiliatingly felt, or which give so sudden a feeling of new life and delight, when we pass from the streets of London to those of Abbeville or Rouen, as the quaint points and pinnacles of the roof gables and turrets. The commonest and heaviest roof may be redeemed by a spike at the end of it, if it is set on with any spirit; but the foreign builders have (or had, at least) a peculiar feeling in this, and gave animation to the whole roof by the fringe of its back, and the spike on its forehead, so that all goes together, like the dorsal fins and spines of a fish; but our spikes have a dull, screwed on, look; a far-off relationship to the nuts of machin-

ery ; and our roof fringes are sure to look like fenders, as if they were meant to catch ashes out of the London smoke-clouds.

§ ix. Stone finials and crockets are, I think, to be considered in architecture, what points and flashes of light are in the color of painting, or of nature. There are some landscapes whose best character is sparkling, and there is a possibility of repose in the midst of brilliancy, or embracing it,—as on the fields of summer sea, or summer land :

“Calm, and deep peace, on this high wold,
And on the dews that drench the furze,
And on the silvery gossamers,
That twinkle into green and gold.”

And there are colorists who can keep their quiet in the midst of a jewellery of light ; but, for the most part, it is better to avoid breaking up either lines or masses by too many points, and to make the few points used exceedingly precious. So the best crockets and finials are set, like stars, along the lines, and at the points, which they adorn, with considerable intervals between them, and exquisite delicacy and fancy of sculpture in their own designs ; if very small, they may become more frequent, and describe lines by a chain of points ; but their whole value is lost if they are gathered into bunches or clustered into tassels and knots ; and an over-indulgence in them always marks lowness of school. In Venice, the addition of the finial to the arch-head is the first sign of degradation ; all her best architecture is entirely without either crockets or finials ; and her ecclesiastical architecture may be classed, with fearless accuracy, as better or worse, in proportion to the diminution or expansion of the crocket. The absolutely perfect use of the crocket is found, I think, in the tower of Giotto, and in some other buildings of the Pisan school. In the North they generally err on one side or other, and are either florid and huge, or mean in outline, looking as if they had been pinched out of the stone-work, as throughout the entire cathedral of Amiens ; and are besides connected with the generally

spotty system which has been spoken of under the head of archivolt decoration.

§ x. Employed, however, in moderation, they are among the most delightful means of delicate expression ; and the architect has more liberty in their individual treatment than in any other feature of the building. Separated entirely from the structural system, they are subjected to no shadow of any other laws than those of grace and chastity ; and the fancy may range without rebuke, for materials of their design, through the whole field of the visible or imaginable creation.

CHAPTER XXX.

THE VESTIBULE.

§ I. I HAVE hardly kept my promise. The reader has decorated but little for himself as yet ; but I have not, at least, attempted to bias his judgment. Of the simple forms of decoration which have been set before him, he has always been left free to choose ; and the stated restrictions in the methods of applying them have been only those which followed on the necessities of construction previously determined. These having been now defined, I do indeed leave my reader free to build ; and with what a freedom ! All the lovely forms of the universe set before him, whence to choose, and all the lovely lines that bound their substance or guide their motion ; and of all these lines,—and there are myriads of myriads in every bank of grass and every tuft of forest ; and groups of them divinely harmonized, in the bell of every flower, and in every several member of bird and beast,—of all these lines, for the principal forms of the most important members of architecture, I have used but Three ! What, therefore, must be the infinity of the treasure in them all ! There is material enough in a single flower for the ornament of a score of cathedrals, but suppose we were satisfied with less exhaustive appliance, and built a score of cathedrals, each to illustrate a single flower ? that would be better than trying to invent new

styles, I think. There is quite difference of style enough, between a violet and a harebell, for all reasonable purposes.

§ II. Perhaps, however, even more strange than the struggle of our architects to invent new styles, is the way they commonly speak of this treasure of natural infinity. Let us take our patience to us for an instant, and hear one of them, not among the least intelligent :—

“It is not true that all natural forms are beautiful. We may hardly be able to detect this in Nature herself ; but when the forms are separated from the things, and exhibited alone (by sculpture or carving), we then see that they are not all fitted for ornamental purposes ; and indeed that very few, perhaps none, are so fitted without correction. Yes, I say *correction*, for though it is the highest aim of every art to imitate nature, this is not to be done by imitating any natural form, but by *criticising* and *correcting* it,—criticising it by Nature’s rules gathered from all her works, but never completely carried out by her in any one work ; correcting it, by rendering it more natural, *i. e.* more conformable to the general tendency of Nature, according to that noble maxim recorded of Raffaelle, ‘that the artist’s object was to make things not as Nature makes them, but as she would make them ;’ as she ever tries to make them, but never succeeds, though her aim may be deduced from a comparison of her efforts ; just as if a number of archers had aimed unsuccessfully at a mark upon a wall, and this mark were then removed, we could by the examination of their arrow marks point out the most probable position of the spot aimed at, with a certainty of being nearer to it than any of their shots.”*

§ III. I had thought that, by this time, we had done with that stale, second-hand, one-sided, and misunderstood saying of Raffaelle’s ; or that at least, in these days of purer Christian light, men might have begun to get some insight into the meaning of it : Raffaelle was a painter of humanity, and assuredly there is something the matter with humanity, a few *dovrebbe’s*, more or less, wanting in it. We have most of us heard of original sin, and may perhaps, in our modest moments, conjecture that we are not quite what God, or nature, would

* Garbett on Design, p. 74.

have us to be. Raffaele *had* something to mend in Humanity: I should have liked to have seen him mending a daisy!—or a pease-blossom, or a moth, or a mustard seed, or any other of God's slightest works. If he had accomplished that, one might have found for him more respectable employment,—to set the stars in better order, perhaps (they seem grievously scattered as they are, and to be of all manner of shapes and sizes,—except the ideal shape, and the proper size); or to give us a corrected view of the ocean; that, at least, seems a very irregular and improveable thing; the very fishermen do not know, this day, how far it will reach, driven up before the west wind:—perhaps Some One else does, but that is not our business. Let us go down and stand by the beach of it,—of the great irregular sea, and count whether the thunder of it is not out of time. One,—two:—here comes a well-formed wave at last, trembling a little at the top, but, on the whole, orderly. So, crash among the shingle, and up as far as this grey pebble; now stand by and watch! Another:—Ah, careless wave! why couldn't you have kept your crest on? it is all gone away into spray, striking up against the cliffs there—I thought as much—missed the mark by a couple of feet! Another:—How now, impatient one! couldn't you have waited till your friend's reflux was done with, instead of rolling yourself up with it in that unseemly manner? You go for nothing. A fourth, and a goodly one at last. What think we of yonder slow rise, and crystalline hollow, without a flaw? Steady, good wave; not so fast; not so fast; where are you coming to?—By our architectural word, this is too bad; two yards over the mark, and ever so much of you in our face besides; and a wave which we had some hope of, behind there, broken all to pieces out at sea, and laying a great white table-cloth of foam all the way to the shore, as if the marine gods were to dine off it! Alas, for these unhappy arrow shots of Nature; she will never hit her mark with those unruly waves of hers, nor get one of them into the ideal shape, if we wait for a thousand years. Let us send for a Greek architect to do it for her. He comes—the great Greek architect, with measure and rule. Will he not also make the weight for the winds? and weigh out the waters

by measure? and make a decree for the rain, and a way for the lightning of the thunder? He sets himself orderly to his work, and behold! this is the mark of nature, and this is the thing into which the great Greek architect improves the sea—

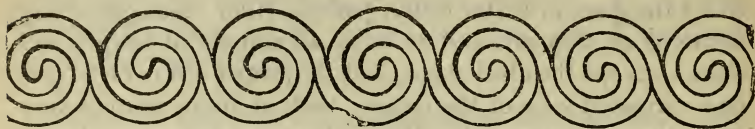

Θάλαττα, θάλαττα: Was it this, then, that they wept to see from the sacred mountain—those wearied ones?

§ iv. But the sea was meant to be irregular! Yes, and were not also the leaves, and the blades of grass; and, in a sort, as far as may be without mark of sin, even the countenance of man? Or would it be pleasanter and better to have us all alike, and numbered on our foreheads, that we might be known one from the other?

§ v. Is there, then, nothing to be done by man's art? Have we only to copy, and again copy, for ever, the imagery of the universe? Not so. We have work to do upon it; there is not any one of us so simple, nor so feeble, but he has work to do upon it. But the work is not to improve, but to explain. This infinite universe is unfathomable, inconceivable, in its whole; every human creature must slowly spell out, and long contemplate, such part of it as may be possible for him to reach; then set forth what he has learned of it for those beneath him; extricating it from infinity, as one gathers a violet out of grass; one does not improve either violet or grass in gathering it, but one makes the flower visible; and then the human being has to make its power upon his own heart visible also, and to give it the honor of the good thoughts it has raised up in him, and to write upon it the history of his own soul. And sometimes he may be able to do more than this, and to set it in strange lights, and display it in a thousand ways before unknown: ways specially directed to necessary and noble purposes, for which he had to choose instruments out of the wide armory of God. All this

he may do: and in this he is only doing what every Christian has to do with the written, as well as the created word, "rightly *dividing* the word of truth." Out of the infinity of the written word, he has also to gather and set forth things new and old, to choose them for the season and the work that are before him, to explain and manifest them to others, with such illustration and enforcement as may be in his power, and to crown them with the history of what, by them, God has done for his soul. And, in doing this, is he improving the Word of God? Just such difference as there is between the sense in which a minister may be said to improve a text, to the people's comfort, and the sense in which an atheist might declare that he could improve the Book, which, if any man shall add unto, there shall be added unto him the plagues that are written therein; just such difference is there between that which, with respect to Nature, man is, in his humbleness, called upon to do, and that which, in his insolence, he imagines himself capable of doing.

§ VI. Have no fear, therefore, reader, in judging between nature and art, so only that you love both. If you can love one only, then let it be Nature; you are safe with her: but do not then attempt to judge the art, to which you do not care to give thought, or time. But if you love both, you may judge between them fearlessly; you may estimate the last, by its making you remember the first, and giving you the same kind of joy. If, in the square of the city, you can find a delight, finite, indeed, but pure and intense, like that which you have in a valley among the hills, then its art and architecture are right; but if, after fair trial, you can find no delight in them, nor any instruction like that of nature, I call on you fearlessly to condemn them.

We are forced, for the sake of accumulating our power and knowledge, to live in cities; but such advantage as we have in association with each other is in great part counterbalanced by our loss of fellowship with nature. We cannot all have our gardens now, nor our pleasant fields to meditate in at eventide. Then the function of our architecture is, as far as may be, to replace these; to tell us about nature; to possess

us with memories of her quietness ; to be solemn and full of tenderness, like her, and rich in portraitures of her ; full of delicate imagery of the flowers we can no more gather, and of the living creatures now far away from us in their own solitude. If ever you felt or found this in a London Street,—if ever it furnished you with one serious thought, or one ray of true and gentle pleasure,—if there is in your heart a true delight in its grim railings and dark casements, and wasteful finery of shops, and feeble coxcombrity of club-houses,—it is well : promote the building of more like them. But if they never taught you anything, and never made you happier as you passed beneath them, do not think they have any mysterious goodness nor occult sublimity. Have done with the wretched affectation, the futile barbarism, of pretending to enjoy : for, as surely as you know that the meadow grass, meshed with fairy rings, is better than the wood pavement, cut into hexagons ; and as surely as you know the fresh winds and sunshine of the upland are better than the choke-damp of the vault, or the gas-light of the ball-room, you may know, as I told you that you should, that the good architecture, which has life, and truth, and joy in it, is better than the bad architecture, which has death, dishonesty, and vexation of heart in it, from the beginning to the end of time.

§ VII. And now come with me, for I have kept you too long from your gondola : come with me, on an autumnal morning, through the dark gates of Padua, and let us take the broad road leading towards the East.

It lies level, for a league or two, between its elms, and vine festoons full laden, their thin leaves veined into scarlet hectic, and their clusters deepened into gloomy blue ; then mounts an embankment above the Brenta, and runs between the river and the broad plain, which stretches to the north in endless lines of mulberry and maize. The Brenta flows slowly, but strongly ; a muddy volume of yellowish-grey water, that neither hastens nor slackens, but glides heavily between its monotonous banks, with here and there a short, babbling eddy twisted for an instant into its opaque surface, and vanishing, as if something had been dragged into it and gone

down. Dusty and shadeless, the road fares along the dyke on its northern side ; and the tall white tower of Dolo is seen trembling in the heat mist far away, and never seems nearer than it did at first. Presently you pass one of the much vaunted "villas on the Brenta : " a glaring, spectral shell of brick and stucco, its windows with painted architraves like picture-frames, and a court-yard paved with pebbles in front of it, all burning in the thick glow of the feverish sunshine, but fenced from the high road, for magnificence sake, with goodly posts and chains ; then another, of Kew Gothic, with Chinese variations, painted red and green ; a third composed for the greater part of dead-wall, with fictitious windows painted upon it, each with a pea-green blind, and a classical architrave in bad perspective ; and a fourth, with stucco figures set on the top of its garden-wall : some antique, like the kind to be seen at the corner of the New Road, and some of clumsy grotesque dwarfs, with fat bodies and large boots. This is the architecture to which her studies of the Renaissance have conducted modern Italy.

§ VIII. The sun climbs steadily, and warms into intense white the walls of the little piazza of Dolo, where we change horses. Another dreary stage among the now divided branches of the Brenta, forming irregular and half-stagnant canals ; with one or two more villas on the other side of them, but these of the old Venetian type, which we may have recognised before at Padua, and sinking fast into utter ruin, black, and rent, and lonely, set close to the edge of the dull water, with what were once small gardens beside them, kneaded into mud, and with blighted fragments of gnarled hedges and broken stakes for their fencing ; and here and there a few fragments of marble steps, which have once given them graceful access from the water's edge, now settling into the mud in broken joints, all aslope, and slippery with green weed. At last the road turns sharply to the north, and there is an open space, covered with bent grass, on the right of it : but do not look that way.

§ IX. Five minutes more, and we are in the upper room of the little inn at Mestre, glad of a moment's rest in shade.

The table is (always, I think) covered with a cloth of nominal white and perennial grey, with plates and glasses at due intervals, and small loaves of a peculiar white bread, made with oil, and more like knots of flour than bread. The view from its balcony is not cheerful: a narrow street, with a solitary brick church and barren campanile on the other side of it; and some conventual buildings, with a few crimson remnants of fresco about their windows; and, between them and the street, a ditch with some slow current in it, and one or two small houses beside it, one with an arbor of roses at its door, as in an English tea-garden; the air, however, about us having in it nothing of roses, but a close smell of garlic and crabs, warmed by the smoke of various stands of hot chestnuts. There is much vociferation also going on beneath the window respecting certain wheelbarrows which are in rivalry for our baggage: we appease their rivalry with our best patience, and follow them down the narrow street.

§ x. We have but walked some two hundred yards when we come to a low wharf or quay, at the extremity of a canal, with long steps on each side down to the water, which latter we fancy for an instant has become black with stagnation; another glance undeceives us,—it is covered with the black boats of Venice. We enter one of them, rather to try if they be real boats or not, than with any definite purpose, and glide away; at first feeling as if the water were yielding continually beneath the boat and letting her sink into soft vacancy. It is something clearer than any water we have seen lately, and of a pale green; the banks only two or three feet above it, of mud and rank grass, with here and there a stunted tree; gliding swiftly past the small casement of the gondola, as if they were dragged by upon a painted scene.

Stroke by stroke we count the plunges of the oar, each heaving up the side of the boat slightly as her silver beak shoots forward. We lose patience, and extricate ourselves from the cushions: the sea air blows keenly by, as we stand leaning on the roof of the floating cell. In front, nothing to be seen but long canal and level bank; to the west, the tower of Mestre is lowering fast, and behind it there have risen pur-

ple shapes, of the color of dead rose-leaves, all round the horizon, feebly defined against the afternoon sky,—the Alps of Bassano. Forward still : the endless canal bends at last, and then breaks into intricate angles about some low bastions, now torn to pieces and staggering in ugly rents towards the water,—the bastions of the fort of Malghera. Another turn, and another perspective of canal ; but not interminable. The silver beak cleaves it fast,—it widens : the rank grass of the banks sinks lower, and lower, and at last dies in tawny knots along an expanse of weedy shore. Over it, on the right, but a few years back, we might have seen the lagoon stretching to the horizon, and the warm southern sky bending over Malamocco to the sea. Now we can see nothing but what seems a low and monotonous dock-yard wall, with flat arches to let the tide through it ;—this is the railroad bridge, conspicuous above all things. But at the end of those dismal arches, there rises, out of the wide water, a straggling line of low and confused brick buildings, which, but for the many towers which are mingled among them, might be the suburbs of an English manufacturing town. Four or five domes, pale, and apparently at a greater distance, rise over the centre of the line ; but the object which first catches the eye is a sullen cloud of black smoke brooding over the northern half of it, and which issues from the belfry of a church.

It is Venice.

APPENDIX.

I. FOUNDATION OF VENICE.

I FIND the chroniclers agree in fixing the year 421, if any : the following sentence from De Monaci may perhaps interest the reader.

“God, who punishes the sins of men by war sorrows, and whose ways are past finding out, willing both to save the innocent blood, and that a great power, beneficial to the whole world, should arise in a spot strange beyond belief, moved the chief men of the cities of the Venetian province (which from the border of Pannonia, extended as far as the Adda, a river of Lombardy), both in memory of past, and in dread of future distress, to establish states upon the nearer islands of the inner gulphs of the Adriatic, to which, in the last necessity, they might retreat for refuge. And first Galienus de Fontana, Simon de Glauconibus, and Antonius Calvus, or, as others have it, Adalburtus Falerius, Thomas Candiano, Comes Daulus, Consuls of Padua, by the command of their King and the desire of the citizens, laid the foundations of the new commonwealth, under good auspices, on the island of the Rialto, the highest and nearest to the mouth of the deep river now called the Brenta, in the year of Our Lord, as many writers assure us, four hundred and twenty-one, on the 25th day of March.”*

It is matter also of very great satisfaction to know that Venice was founded by good Christians : “La qual citade è stada hedificada da veri e boni Christiani :” which informa-

* Ed. Venetis, 1758, Lib. I.

tion I found in the MS. copy of the Zancarol Chronicle, in the library of St. Mark's.

Finally the conjecture as to the origin of her name, recorded by Sansovino, will be accepted willingly by all who love Venice: "Fu interpretato da alcuni, che questa voce VENETIA voglia dire *VENI ETIAM*, cioè, vieni ancora, e ancora, percioche quante volte verrai, sempre vedrai nuove cose, enuove bellezze."

2. POWER OF THE DOGES.

The best authorities agree in giving the year 697 as that of the election of the first doge, Paul Luke Anafeste. He was elected in a general meeting of the commonalty, tribunes, and clergy, at Heraclea, "*divinus rebus procuratis*," as usual, in all serious work, in those times. His authority is thus defined by Sabellico, who was not likely to have exaggerated it:—"Penes quem decus omne imperii ac majestas esset: cui jus concilium cogendi quoties de republica aliquid referri oporteret; qui tribunos annuos in singulas insulas legeret, a quibus ad Duce[m] esset provocatio. Cæterum, si quis dignitatem, ecclesiam, sacerdotumve cleri populique suffragio esset adeptus, ita demum id ratum haberetur si dux ipse auctor factus esset." (Lib. I.) The last clause is very important, indicating the subjection of the ecclesiastical to the popular and ducal (or patrician) powers, which, throughout her career, was one of the most remarkable features in the policy of Venice. The appeal from the tribunes to the doge is also important; and the expression "*decus omne imperii*," if of somewhat doubtful force, is at least as energetic as could have been expected from an historian under the influence of the Council of Ten.

3. SERRAR DEL CONSIGLIO.

The date of the decree which made the right of sitting in the grand council hereditary, is variously given; the Venetian historians themselves saying as little as they can about it. The thing was evidently not accomplished at once, several de-

crees following in successive years: the Council of Ten was established without any doubt in 1310, in consequence of the conspiracy of Tiepolo. The Venetian verse, quoted by Mutinelli (*Annali Urbani di Venezia*, p. 153), is worth remembering.

“ Del mille tresento e diese
 A mezzo el mese delle ceriese
 Bagiamonte passò el ponte
 E per esso fo fatto el Consegio di diese.”

The reader cannot do better than take 1297 as the date of the beginning of the change of government, and this will enable him exactly to divide the 1100 years from the election of the first doge into 600 of monarchy and 500 of aristocracy. The coincidence of the numbers is somewhat curious; 697 the date of the establishment of the government, 1297 of its change, and 1797 of its fall.

4. S. PIETRO DI CASTELLO.

It is credibly reported to have been founded in the seventh century, and (with somewhat less of credibility) in a place where the Trojans, conducted by Antenor, had, after the destruction of Troy, built “un castello, chiamato prima Troja, poscia Olivolo, interpretato, luogo pieno.” It seems that St. Peter appeared in person to the Bishop of Heraclea, and commanded him to found in his honor, a church in that spot of the rising city on the Rialto: “ove avesse veduto una mandra di buoi e di pecore pascolare unitamente. Questa fu la prodigiosa origine della Chiesa di San Pietro, che poscia, o rinnovata, o ristaurata, da Orso Participazio IV Vescovo Olivolense, divenne la Cattedrale della Nuova citta.” (*Notizie Storiche delle Chiese e Monasteri di Venezia*. Padua, 1758.) What there was so prodigious in oxen and sheep feeding together, we need St. Peter, I think, to tell us. The title of Bishop of Castello was first taken in 1091: St. Mark's was not made the cathedral church till 1807. It may be thought hardly fair to conclude the small importance of the old St. Pietro di Castello from the appearance of the wretched modernisations of 1620.

But these modernisations are spoken of as improvements; and I find no notice of peculiar beauties in the older building, either in the work above quoted, or by Sansovino; who only says that when it was destroyed by fire (as everything in Venice was, I think, about three times in a century), in the reign of Vital Michele, it was rebuilt "with good thick walls, maintaining, *for all that*, the order of its arrangement taken from the Greek mode of building." This does not seem the description of a very enthusiastic effort to rebuild a highly ornate cathedral. The present church is among the least interesting in Venice; a wooden bridge, something like that of Battersea on a small scale, connects its island, now almost deserted, with a wretched suburb of the city behind the arsenal; and a blank level of lifeless grass, rotted away in places rather than trodden, is extended before its mildewed façade and solitary tower.

5. PAPAL POWER IN VENICE.

I may refer the reader to the eleventh chapter of the twenty-eighth book of Daru for some account of the restraints to which the Venetian clergy were subjected. I have not myself been able to devote any time to the examination of the original documents bearing on this matter, but the following extract from a letter of a friend, who will not at present permit me to give his name, but who is certainly better conversant with the records of the Venetian State than any other Englishman, will be of great value to the general reader:—

"In the year 1410, or perhaps at the close of the thirteenth century, churchmen were excluded from the Grand Council and declared ineligible to civil employment; and in the same year, 1410, the Council of Ten, with the Giunta, decreed that whenever in the state's councils matters concerning ecclesiastical affairs were being treated, all the kinsfolk of Venetian beneficed clergymen were to be expelled; and, in the year 1434, the RELATIONS of churchmen were declared ineligible to the post of ambassador at Rome.

“The Venetians never gave possession of any see in their territories to bishops unless they had been proposed to the pope by the senate, which elected the patriarch, who was supposed, at the end of the sixteenth century, to be liable to examination by his Holiness, as an act of confirmation of installation ; but of course, everything depended on the relative power at any given time of Rome and Venice : for instance, a few days after the accession of Julius II., in 1503, he requests the Signory, cap in hand, to ALLOW him to confer the archbishopric of Zara on a dependant of his, one Cipico the Bishop of Famagosta. Six years later, when Venice was overwhelmed by the leaguers of Cambrai, that furious pope would assuredly have conferred Zara on Cipico WITHOUT asking leave. In 1608, the rich Camaldolite Abbey of Vangadizza, in the Polesine, fell vacant through the death of Lionardo Loredano, in whose family it had been since some while. The Venetian ambassador at Rome received the news on the night of the 28th December ; and, on the morrow, requested Paul IV. not to dispose of this preferment until he heard from the senate. The pope talked of ‘ poor cardinals ’ and of his nephew, but made no positive reply ; and, as Francesco Contarini was withdrawing, said to him : ‘ My Lord ambassador, with this opportunity we will inform you that, to our very great regret, we understand that the chiefs of the Ten mean to turn sacristans ; for they order the parish priests to close the church doors at the Ave Maria, and not to ring the bells at certain hours. This is precisely the sacristan’s office ; we don’t know why their lordships, by printed edicts, which we have seen, choose to interfere in this matter. This is pure and mere ecclesiastical jurisdiction ; and even, in case of any inconvenience arising, is there not the patriarch, who is at any rate your own ; why not apply to him, who could remedy these irregularities ? These are matters which cause us very notable displeasure ; we say so that they may be written and known : it is decided by the councils and canons, and not uttered by us, that whosoever forms any resolve against the ecclesiastical liberty, cannot do so without incurring censure : and in order that Father Paul [Bacon’s correspondent] may not say hereafter, as he did

in his past writings, that our predecessors assented either tacitly or by permission, we declare that we do not give our assent, nor do we approve it ; nay, we blame it, and let this be announced in Venice, so that, for the rest, every one may take care of his own conscience. St. Thomas à Becket, whose festival is celebrated this very day, suffered martyrdom for the ecclesiastical liberty ; it is our duty likewise to support and defend it.' Contarini says : ' This remonstrance was delivered with some marks of anger, which induced me to tell him how the tribunal of the most excellent the Lords chiefs of the Ten is in our country supreme ; that it does not do its business unadvisedly, or condescend to unworthy matters ; and that, therefore, should those Lords have come to any public declaration of their will, it must be attributed to orders anterior, and to immemorial custom and authority, recollecting that, on former occasions likewise, similar commissions were given to prevent divers incongruities ; wherefore an upright intention, such as this, ought not to be taken in any other sense than its own, especially as the parishes of Venice were in her own gift,' &c. &c. The pope persisted in bestowing the abbacy on his nephew, but the republic would not give possession, and a compromise was effected by its being conferred on the Venetian Matteo Priuli, who allowed the cardinal five thousand ducats per annum out of its revenues. A few years before this, this very same pope excommunicated the State, because she had imprisoned two churchmen for heinous crimes ; the strife lasted for more than a year, and ended through the mediation of Henry IV., at whose suit the prisoners were delivered to the French ambassador, who made them over to a papal commissioner.

"In January, 1484, a tournament was in preparation on St. Mark's Square : some murmurs had been heard about the distribution of the prizes having been pre-arranged, without regard to the ' best man.' One of the chiefs of the Ten was walking along Rialto on the 28th January, when a young priest, twenty-two years old, a sword-cutler's son, and a Bolognese, and one of Perugia, both men-at-arms under Robert Sansoverino, fell upon a clothier with drawn weapons. The

chief of the Ten desired they might be seized, but at the moment the priest escaped ; he was, however, subsequently retaken, and in that very evening hanged by torch-light between the columns with the two soldiers. Innocent VIII. was less powerful than Paul IV. ; Venice weaker in 1605 than in 1484.

“ * * * The exclusion from the Grand Council, whether at the end of the fourteenth or commencement of the following century, of the Venetian ecclesiastics, (as induced either by the republic's acquisitions on the main land then made, and which, through the rich benefices they embraced, might have rendered an ambitious churchman as dangerous in the Grand Council as a victorious condottiere ; or from dread of their allegiance being divided between the church and their country, it being acknowledged that no man can serve two masters,) did not render them hostile to their fatherland, whose interests were, with very few exceptions, eagerly fathered by the Venetian prelates at Rome, who, in their turn, received all honor at Venice, where state receptions given to cardinals of the houses of Correr, Grimani, Cornaro, Pisani, Contarini, Zeno, Delfino, and others, vouch for the good understanding that existed between the ‘ Papalists ’ and their countrymen. The Cardinal Grimani was instrumental in detaching Julius II. from the league of Cambrai ; the Cardinal Cornaro always aided the state to obtain anything required of Leo X. ; and, both before and after their times, all Venetians that had a seat in the Sacred College were patriots rather than pluralists : I mean that they cared more for Venice than for their benefices, admitting thus the soundness of that policy which denied them admission into the Grand Council.”

To this interesting statement, I shall add, from the twenty-eighth book of Daru, two passages, well deserving consideration by us English in present days :

“ Pour être parfaitement assurée contre les envahissements de la puissance ecclésiastique, Venise commença par lui ôter tout prétexte d'intervenir dans les affaires de l'État ; elle resta invariablement fidèle au dogme. Jamais aucune des opinions nouvelles n'y prit la moindre faveur ; jamais aucun hérésiarque ne sortit de Venise. Les conciles, les disputes, les guerres de

religion, se passèrent sans qu'elle y prit jamais la moindre part. Inébranlable dans sa foi, elle ne fut pas moins invariable dans son système de tolérance. Non seulement ses sujets de la religion grecque conservèrent l'exercice de leur culte, leurs évêques et leurs prêtres; mais les Protestantes, les Arméniens, les Mahomitans, les Juifs, toutes les religions, toutes les sectes qui se trouvaient dans Venise, avaient des temples, et la sépulture dans les églises n'était point refusé aux hérétiques. Une police vigilante s'appliquait avec le même soin à éteindre les discordes, et à empêcher les fanatiques et les novateurs de troubler l'Etat."

* * * * *

"Si on considère que c'est dans un temps où presque toutes les nations tremblaient devant la puissance pontificale, que les Vénitiens surent tenir leur clergé dans la dépendance, et braver souvent les censures ecclésiastiques et les interdits, sans encourir jamais aucun reproche sur la pureté de leur foi, on sera forcé de reconnaître que cette république avait devancé de loin les autres peuples dans cette partie de la science du gouvernement. La fameuse maxime, 'Siamo veneziani, poi cristiani,' n'était qu'une formule énergique qui ne prouvait point qu'ils voulussent placer l'intérêt de la religion après celui de l'Etat, mais qui annonçait leur invariable résolution de ne pas souffrir qu'un pouvoir étranger portât atteinte aux droits de la république.

"Dans toute la durée de son existence, au milieu des revers comme dans la prospérité, cet inébranlable gouvernement ne fit qu'une seule fois des concessions à la cour de Rome, et ce fut pour détacher le Pape Jules II. de la ligue de Cambrai.

"Jamais il ne se relâcha du soin de tenir le clergé dans une nullité absolue relativement aux affaires politiques; on peut en juger par la conduite qu'il tint avec l'ordre religieux le plus redoutable et le plus accoutumé à s'immiscer dans les secrets de l'Etat et dans les intérêts temporels."

The main points, next stated, respecting the Jesuits are, that the decree which permitted their establishment in Venice required formal renewal every three years; that no Jesuit could stay in Venice more than three years; that the slightest

disobedience to the authority of the government was instantly punished by imprisonment ; that no Venetian could enter the order without express permission from the government ; that the notaries were forbidden to sanction any testamentary disposal of property to the Jesuits ; finally, that the heads of noble families were forbidden to permit their children to be educated in the Jesuits' colleges, on pain of degradation from their rank.

Now, let it be observed that the enforcement of absolute exclusion of the clergy from the councils of the state, dates exactly from the period which I have marked for the commencement of the decline of the Venetian power. The Romanist is welcome to his advantage in this fact, if advantage it be ; for I do not bring forward the conduct of the senate of Venice, as Daru does, by way of an example of the general science of government. The Venetians accomplished therein what we ridiculously call a separation of " Church and State " (as if the State were not, in all Christendom, necessarily also the Church*), but *ought* to call a separation of lay and clerical officers. I do not point out this separation as subject of praise, but as the witness borne by the Venetians against the principles of the Papacy. If they were to blame, in yielding to their fear of the ambitious spirit of Rome so far as to deprive their councils of all religious element, what excuse are we to offer for the state, which, with Lords Spiritual of her own faith already in her senate, permits the polity of Rome to be represented by lay members ? To have sacrificed religion to mistaken policy, or purchased security with ignominy, would have been no new thing in the world's history ; but to be at once impious and impolitic, and seek for danger through dishonor, was reserved for the English parliament of 1829.

I am glad to have this opportunity of referring to, and farther enforcing, the note on this subject which, not without deliberation, I appended to the " Seven Lamps ; " and of adding to it the following passage, written by my father in the year 1839, and published in one of the journals of that year :

* Compare Appendix 12.

—a passage remarkable as much for its intrinsic value, as for having stated, twelve years ago, truths to which the mind of England seems but now, and that slowly, awakening.

“ We hear it said, that it cannot be merely the Roman religion that causes the difficulty [respecting Ireland], for we were once all Roman Catholics, and nations abroad of this faith are not as the Irish. It is totally overlooked, that when we were so, our government was despotic, and fit to cope with this dangerous religion, as most of the Continental governments yet are. In what Roman Catholic state, or in what age of Roman Catholic England, did we ever hear of such agitation as now exists in Ireland by evil men taking advantage of an anomalous state of things—Roman Catholic ignorance in the people, Protestant toleration in the government? We have yet to feel the tremendous difficulty in which Roman Catholic emancipation has involved us. Too late we discover that a Roman Catholic is wholly incapable of being safely connected with the British constitution, as it now exists, *in any near relation*. The present constitution is no longer fit for Catholics. It is a creature essentially Protestant, growing with the growth, and strengthening with the strength, of Protestantism. So entirely is Protestantism interwoven with the whole frame of our constitution and laws, that I take my stand on this, against all agitators in existence, that the Roman religion is totally incompatible with the British constitution. We have, in trying to combine them, got into a maze of difficulties; we are the worse, and Ireland none the better. It is idle to talk of municipal reform or popular Lords Lieutenant. The mild sway of a constitutional monarchy is not strong enough for a Roman Catholic population. The stern soul of a Republican would not shrink from sending half the misguided population and all the priests into exile, and planting in their place an industrious Protestant people. But you cannot do this, and you cannot convert the Irish, nor by other means make them fit to wear the mild restraints of a Protestant Government. It was, moreover, a strange logic that begot the idea of admitting Catholics to administer any part of our laws or constitution. It was admitted by all that, by the very act of aban-

doing the Roman religion, we became a free and enlightened people. It was only by throwing off the yoke of that slavish religion that we attained to the freedom of thought which has advanced us in the scale of society. We are so much advanced by adopting and adhering to a reformed religion, that to prove our liberal and unprejudiced views, we throw down the barriers betwixt the two religions, of which the one is the acknowledged cause of light and knowledge, the other the cause of darkness and ignorance. We are so much altered to the better by leaving this people entirely, and giving them neither part nor lot amongst us, that it becomes proper to mingle again with them. We have found so much good in leaving them, that we deem it the best possible reason for returning to be among them. No fear of their Church again shaking us, with all our light and knowledge. It is true, the most enlightened nations fell under the spell of her enchantments, fell into total darkness and superstition; but no fear of us—we are too well informed! What miserable reasoning! infatuated presumption! I fear me, when the Roman religion rolled her clouds of darkness over the earlier ages, that she quenched as much light, and knowledge, and judgment as our modern Liberals have ever displayed. I do not expect a statesman to discuss the point of Transubstantiation betwixt Protestant and Catholic, nor to trace the narrow lines which divide Protestant sectarians from each other; but can any statesman that shall have taken even a cursory glance at the face of Europe, hesitate a moment on the choice of the Protestant religion? If he unfortunately knew nothing of its being the true one in regard to our eternal interests, he is at least bound to see whether it be not the best for the worldly prosperity of a people. He may be but moderately imbued with pious zeal for the salvation of a kingdom, but at least he will be expected to weigh the comparative merits of religion, as of law or government; and blind, indeed, must he be if he does not discern that, in neglecting to cherish the Protestant faith, or in too easily yielding to any encroachments on it, he is foregoing the use of a state engine more powerful than all the laws which the uninspired legislators of the earth have

ever promulgated, in promoting the happiness, the peace, prosperity, and the order, the industry, and the wealth, of a people ; in forming every quality valuable or desirable in a subject or a citizen ; in sustaining the public mind at that point of education and information that forms the best security for the state, and the best preservative for the freedom of a people, whether religious or political."

6. RENAISSANCE ORNAMENTS.

There having been three principal styles of architecture in Venice,—the Greek or Byzantine, the Gothic, and the Renaissance, it will be shown, in the sequel, that the Renaissance itself is divided into three correspondent families : Renaissance engrafted on Byzantine, which is earliest and best ; Renaissance engrafted on Gothic, which is second, and second best ; Renaissance on Renaissance, which is double darkness, and worst of all. The palaces in which Renaissance is engrafted on Byzantine are those noticed by Comynes : they are characterized by an ornamentation very closely resembling, and in some cases identical with, early Byzantine work ; namely, groups of colored marble circles inclosed in interlacing bands. I have put on the opposite page one of these ornaments, from the Ca' Trevisan, in which a most curious and delicate piece of inlaid design is introduced into a band which is almost exactly copied from the church of Theotocos at Constantinople, and correspondent with others in St. Mark's. There is also much Byzantine feeling in the treatment of the animals, especially in the two birds of the lower compartment, while the peculiar curves of the cinque cento leafage are visible in the leaves above. The dove, alighted, with the olive-branch plucked off, is opposed to the raven with restless expanded wings. Beneath are evidently the two sacrifices "of every clean fowl and of every clean beast." The color is given with green and white marbles, the dove relieved on a ground of grayish green, and all is exquisitely finished.

In Plate I, p. 27, the upper figure is from the same palace (Ca' Trevisan), and it is very interesting in its proportions. If

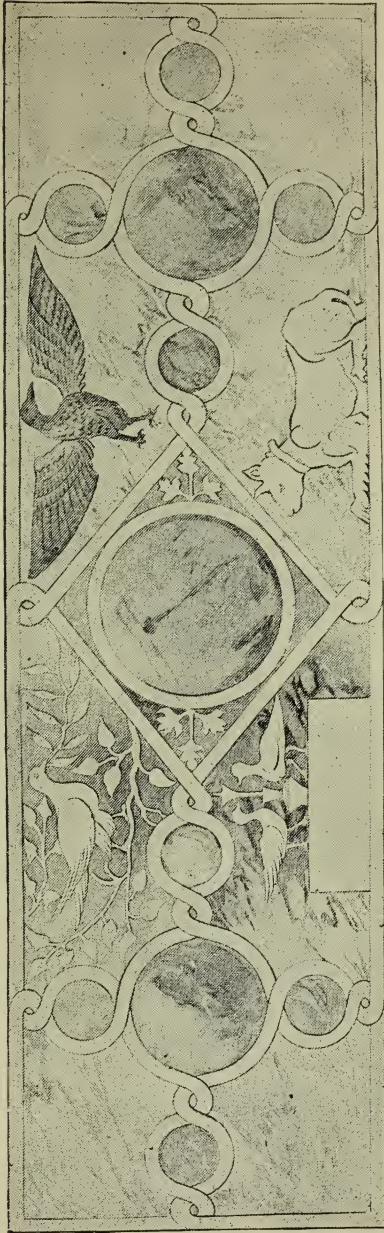

PLATE XX. — WALL-VEIL DECORATION. CA' TREVISAN.

we take five circles in geometrical proportion, each diameter being two-thirds of the diameter next above it, and arrange the circles so proportioned, in contact with each other, in the manner shown in the plate, we shall find that an increase quite imperceptible in the diameter of the circles in the angles, will enable us to inscribe the whole in a square. The lines so described will then run in the centre of the white bands. I cannot be certain that this is the actual construction of the Trevisan design, because it is on a high wall surface, where I could not get at its measurements; but I found this construction exactly coincide with the lines of my eye sketch. The lower figure in Plate I. is from the front of the Ca' Dario, and probably struck the eye of Commynes in its first brightness. Salvatico, indeed, considers both the Ca' Trevisan (which once belonged to Bianca Cappello) and the Ca' Dario, as buildings of the sixteenth century. I defer the discussion of the question at present, but have, I believe, sufficient reason for assuming the Ca' Dario to have been built about 1486, and the Ca' Trevisan not much later.

7. VARIETIES OF THE ORDERS.

Of these phantasms and grotesques, one of some general importance is that commonly called Ionic, of which the idea was taken (Vitruvius says) from a woman's hair, curled; but its lateral processes look more like rams' horns: be that as it may, it is a mere piece of agreeable extravagance, and if, instead of rams' horns, you put ibex horns, or cows' horns, or an ass's head at once, you will have ibex orders, or ass orders, or any number of other orders, one for every head or horn. You may have heard of another order, the Composite, which is Ionic and Corinthian mixed, and is one of the worst of ten thousand forms referable to the Corinthian as their head: it may be described as a spoiled Corinthian. And you may have also heard of another order, called Tuscan (which is no order at all, but a spoiled Doric): and of another called Roman Doric, which is Doric more spoiled, both which are simply among the most stupid variations ever invented upon forms

already known. I find also in a French pamphlet upon architecture,* as applied to shops and dwelling houses, a sixth order, the "Ordre Français," at least as good as any of the three last, and to be hailed with acclamation, considering whence it comes, there being usually more tendency on the other side of the channel to the confusion of "orders" than their multiplication: but the reader will find in the end that there are in very deed only two orders, of which the Greek, Doric, and Corinthian are the first examples, and *they* not perfect, nor in anywise sufficiently representative of the vast families to which they belong; but being the first and the best known, they may properly be considered as the types of the rest. The essential distinctions of the two great orders he will find explained in §§ xxxv. and xxxvi. of Chap. XXVII., and in the passages there referred to; but I should rather desire that these passages might be read in the order in which they occur.

8. THE NORTHERN ENERGY.

I have sketched above, in the First Chapter, the great events of architectural history in the simplest and fewest words I could; but this indraught of the Lombard energies upon the Byzantine rest, like a wild north wind descending into a space of rarified atmosphere, and encountered by an Arab simoom from the south, may well require from us some farther attention; for the differences in all these schools are more in the degrees of their impetuosity and refinement (these qualities being, in most cases, in inverse ratio, yet much united by the Arabs) than in the style of the ornaments they employ. The same leaves, the same animals, the same arrangements, are used by Scandinavians, ancient Britons, Saxons, Normans,

* *L'Artiste en Bâtimens*, par Louis Berteaux: Dijon, 1848. My printer writes at the side of the page a note, which I insert with thanks:—"This is not the first attempt at a French order. The writer has a Treatise by Sebastian Le Clerc, a great man in his generation, which contains a Roman order, a Spanish order, which the inventor appears to think very grand, and a *new* French order nationalised by the Gallic cock crowing and clapping its wings in the capital."

Lombards, Romans, Byzantines, and Arabians ; all being alike descended through classic Greece from Egypt and Assyria, and some from Phœnicia. The belts which encompass the Assyrian bulls, in the hall of the British Museum, are the same as the belts of the ornaments found in Scandinavian tumuli ; their method of ornamentation is the same as that of the gate of Mycenæ, and of the Lombard pulpit of St. Ambrogio of Milan, and of the church of Theotocos at Constantinople ; the essential differences among the great schools are their differences of temper and treatment, and science of expression ; it is absurd to talk of Norman ornaments, and Lombard ornaments, and Byzantine ornaments, as formally distinguished ; but there is irreconcilable separation between Arab temper, and Lombard temper, and Byzantine temper.

Now, as far as I have been able to compare the three schools, it appears to me that the Arab and Lombard are both distinguished from the Byzantine by their energy and love of excitement, but the Lombard stands alone in his love of jest : Neither an Arab nor Byzantine ever jests in his architecture ; the Lombard has great difficulty in ever being thoroughly serious ; thus they represent three conditions of humanity, one in perfect rest, the Byzantine, with exquisite perception of grace and dignity ; the Arab, with the same perception of grace, but with a restless fever in his blood ; the Lombard, equally energetic, but not burning himself away, capable of submitting to law, and of enjoying jest. But the Arabian feverishness infects even the Lombard in the South, showing itself, however, in endless invention, with a refreshing firmness and order directing the whole of it. The excitement is greatest in the earliest times, most of all shown in St. Michele of Pavia ; and I am strongly disposed to connect much of its peculiar manifestations with the Lombard's habits of eating and drinking, especially his carnivorousness. The Lombard of early times seems to have been exactly what a tiger would be, if you could give him love of a joke, vigorous imagination, strong sense of justice, fear of hell, knowledge of northern mythology a stone den, and a mallet and chisel ; fancy him pacing up and down in the said den to digest his dinner, and

striking on the wall, with a new fancy in his head, at every turn, and you have the Lombardic sculptor. As civilisation increases the supply of vegetables, and shortens that of wild beasts, the excitement diminishes; it is still strong in the thirteenth century at Lyons and Rouen; it dies away gradually in the later Gothic, and is quite extinct in the fifteenth century.

I think I shall best illustrate this general idea by simply copying the entries in my diary which were written when, after six months' close study of Byzantine work in Venice, I came again to the Lombard work of Verona and Pavia. There are some other points alluded to in these entries not pertaining to the matter immediately in hand; but I have left them, as they will be of use hereafter.

“(Verona.) Comparing the arabesque and sculpture of the Duomo here with St. Mark's, the first thing that strikes one is the low relief, the second, the greater motion and spirit, with infinitely less grace and science. With the Byzantine, however rude the cutting, every line is lovely, and the animals or men are placed in any attitudes which secure ornamental effect, sometimes impossible ones, always severe, restrained, or languid. With the Romanesque workmen all the figures show the effort (often successful) to express energetic action; hunting chiefly, much fighting, and both spirited; some of the dogs running capittally, straining to it, and the knights hitting hard, while yet the faces and drawing are in the last degree barbarous. At Venice all is graceful, fixed, or languid; the eastern torpor is in every line,—the mark of a school formed on severe traditions, and keeping to them, and never likely or desirous to rise beyond them, but with an exquisite sense of beauty, and much solemn religious faith.

“If the Greek outer archivolt of St. Mark's is Byzantine, the law is somewhat broken by its busy domesticity; figures engaged in every trade, and in the preparation of viands of all kinds; a crowded kind of London Christmas scene, interleaved (literally) by the superb balls of leafage, unique in sculpture; but even this is strongly opposed to the wild war and chase passion of the Lombard. Farther, the Lombard

building is as sharp, precise, and accurate, as that of St. Mark's is careless. The Byzantines seem to have been too lazy to put their stones together ; and, in general, my first impression on coming to Verona, after four months in Venice, is of the exquisitely neat masonry and perfect *feeling* here ; a style of Gothic formed by a combination of Lombard surface ornament with Pisan Gothic, than which nothing can possibly be more chaste, pure, or solemn."

I have said much of the shafts of the entrance to the crypt of St. Zeno ;* the following note of the sculptures on the archivolt above them is to our present purpose :

"It is covered by very light but most effective bas-reliefs of jesting subject :—two cocks carrying on their shoulders a long staff to which a fox (?) is tied by the legs, hanging down between them : the strut of the foremost cock, lifting one leg at right angles to the other, is delicious. Then a stag hunt, with a centaur horseman drawing a bow ; the arrow has gone clear through the stag's throat, and is sticking there. Several capital hunts with dogs, with fruit trees between, and birds in them ; the leaves, considering the early time, singularly well set, with the edges outwards, sharp, and deep cut : snails and frogs filling up the intervals, as if suspended in the air, with some saucy puppies on their hind legs, two or three nondescript beasts ; and, finally, on the centre of one of the arches on the south side, an elephant and castle,—a very strange elephant, yet cut as if the carver had seen one.

Observe this elephant and castle ; we shall meet with him farther north.

"These sculptures of St. Zeno are, however, quite quiet and tame compared with those of St. Michele of Pavia, which are designed also in a somewhat gloomier mood ; significative, as I think, of indigestion. (Note that they are much earlier than St. Zeno ; of the seventh century at latest. There is more of nightmare, and less of wit in them.) Lord Lindsay has described them admirably, but has not said half enough ; the state of mind represented by the west front is more that of a

* The lower group in Plate XVII.

feverish dream, than resultant from any determined architectural purpose, or even from any definite love and delight in the grotesque. One capital is covered with a mass of grinning heads, other heads grow out of two bodies, or out of and under feet; the creatures are all fighting, or devouring, or struggling which shall be uppermost, and yet in an ineffectual way, as if they would fight for ever, and come to no decision. Neither sphinxes nor centaurs did I notice, nor a single peacock (I believe peacocks to be purely Byzantine), but mermaids with *two* tails (the sculptor having perhaps seen double at the time), strange, large fish, apes, stags (bulls?), dogs, wolves, and horses, griffins, eagles, long-tailed birds (cocks?), hawks, and dragons, without end, or with a dozen of ends, as the case may be; smaller birds, with rabbits, and small nondescripts, filling the friezes. The actual leaf, which is used in the best Byzantine mouldings at Venice, occurs in parts of these Pavian designs. But the Lombard animals are all *alive*, and fiercely alive too, all impatience and spring: the Byzantine birds peck idly at the fruit, and the animals hardly touch it with their noses. The cinque cento birds in Venice hold it up daintily, like train-bearers; the birds in the earlier Gothic peck at it hungrily and naturally; but the Lombard beasts gripe at it like tigers, and tear it off with writhing lips and glaring eyes. They are exactly like Jip with the bit of geranium, worrying imaginary cats in it."

The notice of the leaf in the above extract is important,—it is the vine-leaf; used constantly both by Byzantines and Lombards, but by the latter with especial frequency, though at this time they were hardly able to indicate what they meant. It forms the most remarkable generality of the St. Michele decoration; though, had it not luckily been carved on the façade, twining round a stake, and with grapes, I should never have known what it was meant for, its general form being a succession of sharp lobes, with incised furrows to the point of each. But it is thrown about in endless change; four or five varieties of it might be found on every cluster of capitals: and not content with this, the Lombards hint the same form even in their griffin wings. They love the vine very heartily.

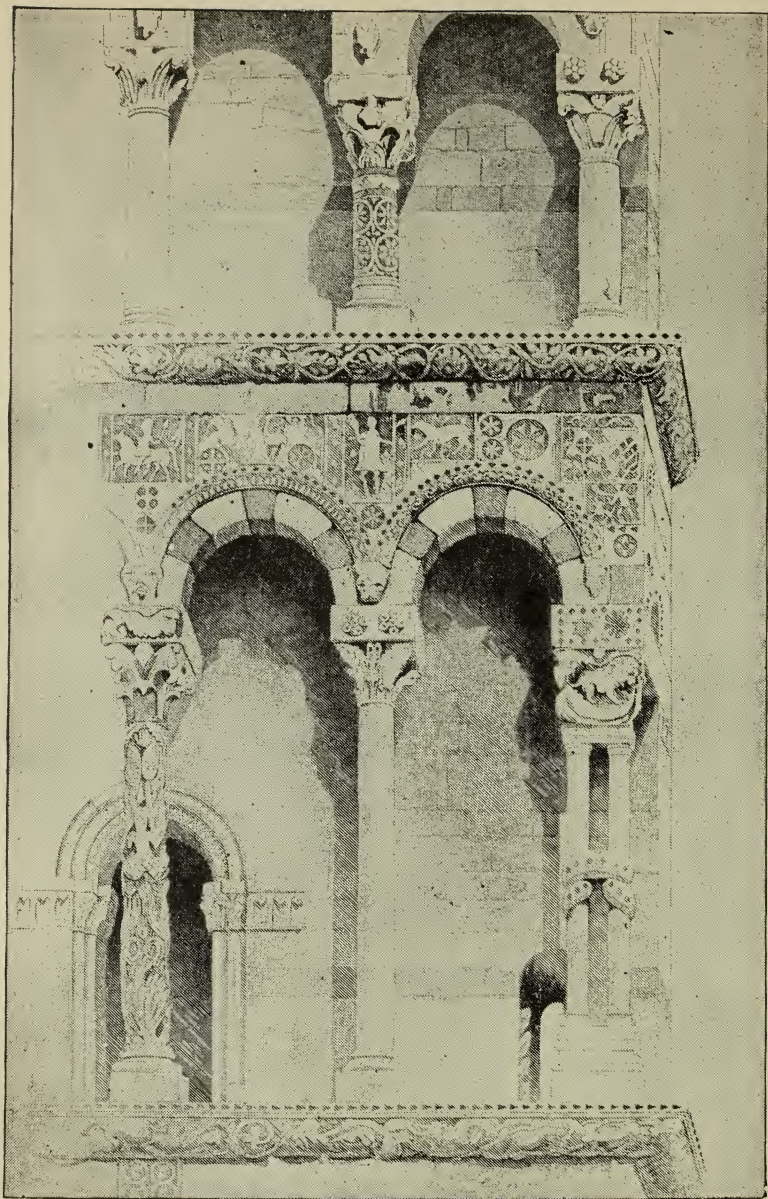

PLATE XXI.—WALL-VEIL DECORATION.

In St. Michele of Lucca we have perhaps the noblest instance in Italy of the Lombard spirit in its later refinement. It is some four centuries later than St. Michele of Pavia, and the method of workmanship is altogether different. In the Pavian church, nearly all the ornament is cut in a coarse sandstone, in bold relief : a darker and harder stone (I think, not serpentine, but its surface is so disguised by the lustre of ages that I could not be certain) is used for the capitals of the western door, which are especially elaborate in their sculpture ;—two devilish apes, or apish devils, I know not which, with bristly moustaches and edgy teeth, half-crouching, with their hands impertinently on their knees, ready for a spit or a spring if one goes near them ; but all is pure bossy sculpture ; there is no inlaying, except of some variegated tiles in the shape of saucers set concave (an ornament used also very gracefully in St. Jacopo of Bologna) : and the whole surface of the church is enriched with the massy reliefs, well preserved everywhere above the reach of human animals, but utterly destroyed to some five or six feet from the ground ; worn away into large cellular hollows and caverns, some almost deep enough to render the walls unsafe, entirely owing to the uses to which the recesses of the church are dedicated by the refined and high-minded Italians. But St. Michele of Lucca is wrought entirely in white marble and green serpentine ; there is hardly any relieved sculpture except in the capitals of the shafts and cornices, and all the designs of wall ornament are inlaid with exquisite precision—white on dark ground ; the ground being cut out and filled with serpentine, the figures left in solid marble. The designs of the Pavian church are encrusted on the walls ; of the Lucchese, incorporated with them ; small portions of real sculpture being introduced exactly where the eye, after its rest on the flatness of the wall, will take most delight in the piece of substantial form. The entire arrangement is perfect beyond all praise, and the morbid restlessness of the old designs is now appeased. Geometry seems to have acted as a febrifuge, for beautiful geometrical designs are introduced amidst the tumult of the hunt ; and there is no more seeing double, nor ghastly monstrosity of conception ; no more

ending of everything in something else ; no more disputing for spare legs among bewildered bodies ; no more setting on of heads wrong side foremost. The fragments have come together : we are out of the Inferno with its weeping down the spine ; we are in the fair hunting-fields of the Lucchese mountains (though they had their tears also),—with horse, and hound, and hawk ; and merry blast of the trumpet.—Very strange creatures to be hunted, in all truth ; but still creatures with a single head, and that on their shoulders, which is exactly the last place in the Pavian church where a head is to be looked for.

My good friend Mr. Cockerell wonders, in one of his lectures, why I give so much praise to this “crazy front of Lucca.” But it is not crazy ; not by any means. Altogether sober, in comparison with the early Lombard work, or with our Norman. Crazy in one sense it is : utterly neglected, to the breaking of its old stout heart ; the venomous nights and salt frosts of the Maremma winters have their way with it—“Poor Tom’s a cold !” The weeds that feed on the marsh air, have twisted themselves into its crannies ; the polished fragments of serpentine are split and rent out of their cells, and lie in green ruins along its ledges ; the salt sea winds have eaten away the fair shafting of its star window into a skeleton of crumbling rays. It cannot stand much longer ; may Heaven only, in its benignity, preserve it from restoration, and the sands of the Serchio give it honorable grave.

In the “Seven Lamps,” Plate VI., I gave a faithful drawing of one of its upper arches, to which I must refer the reader ; for there is a marked piece of character in the figure of the horseman on the left of it. And in making this reference, I would say a few words about those much abused plates of the “Seven Lamps.” They are black, they are overbitten, they are hastily drawn, they are coarse and disagreeable ; how disagreeable to many readers I venture not to conceive. But their truth is carried to an extent never before attempted in architectural drawing. It does not in the least follow that because a drawing is delicate, or looks careful, it has been carefully drawn from the thing represented ; in nine instances

out of ten, careful and delicate drawings are made at home. It is not so easy as the reader, perhaps, imagines, to finish a drawing altogether on the spot, especially of details seventy feet from the ground ; and any one who will try the position in which I have had to do some of my work—standing, namely, on a cornice or window sill, holding by one arm round a shaft, and hanging over the street (or canal, at Venice), with my sketch-book supported against the wall from which I was drawing, by my breast, so as to leave my right hand free—will not thenceforward wonder that shadows should be occasionally carelessly laid in, or lines drawn with some unsteadiness. But, steady, or infirm, the sketches of which those plates in the “Seven Lamps” are fac-similes, were made from the architecture itself, and represent that architecture with its actual shadows at the time of day at which it was drawn, and with every fissure and line of it as they now exist ; so that when I am speaking of some new point, which perhaps the drawing was not intended to illustrate, I can yet turn back to it with perfect certainty that if anything be found in it bearing on matters now in hand, I may depend upon it just as securely as if I had gone back to look again at the building.

It is necessary that my readers should understand this thoroughly, and I did not before sufficiently explain it ; but I believe I can show them the use of this kind of truth, now that we are again concerned with this front of Lucca. They will find a drawing of the entire front in Gally Knight’s “Architecture of Italy.” It may serve to give them an idea of its general disposition, and it looks very careful and accurate ; but every bit of the ornament on it is *drawn out of the artist’s head*. There is not *one line* of it that exists on the building. The reader will therefore, perhaps, think my ugly black plate of somewhat more value, upon the whole, in its rough veracity, than the other in its delicate fiction.*

* One of the upper stories is also in Gally Knight’s plate represented as merely banded, and otherwise plain : it is, in reality, covered with as delicate inlaying as the rest. The whole front is besides out of proportion, and out of perspective, at once ; and yet this work is referred

As, however, I made a drawing of another part of the church somewhat more delicately, and as I do not choose that my favorite church should suffer in honor by my coarse work, I have had this, as far as might be, fac-similied by line engraving (Plate XXI.). It represents the southern side of the lower arcade of the west front; and may convey some idea of the exquisite finish and grace of the whole; but the old plate, in the "Seven Lamps," gives a nearer view of one of the upper arches, and a more faithful impression of the present aspect of the work, and especially of the seats of the horse-men; the limb straight, and well down on the stirrup (the warrior's seat, observe, not the jockey's), with a single pointed spur on the heel. The bit of the lower cornice under this arch I could not see, and therefore had not drawn; it was supplied from beneath another arch. I am afraid, however, the reader has lost the thread of my story while I have been recommending my veracity to him. I was insisting upon the healthy tone of this Lucca work as compared with the old spectral Lombard friezes. The apes of the Pavian church ride without stirrups, but all is in good order and harness here: civilisation had done its work; there was reaping of corn in the Val d'Arno, though rough hunting still upon its hills. But in the north, though a century or two later, we find the forests of the Rhone, and its rude limestone cotes, haunted by phantasms still (more meat-eating, then, I think). I do not know a more interesting group of cathedrals than that of Lyons, Vienne, and Valencia: a more interesting indeed, generally, than beautiful; but there is a row of niches on the west front of Lyons, and a course of panelled decoration about its doors, which is, without exception, the most exquisite piece of Northern Gothic I ever beheld, and with which I

to as of authority, by our architects. Well may our architecture fall from its place among the fine arts, as it is doing rapidly; nearly all our works of value being devoted to the Greek architecture, which is *utterly useless* to us—or worse. One most noble book, however has been dedicated to our English abbeys,—Mr. E. Sharpe's "Architectural Parallels"—almost a model of what I should like to see done for the Gothic of all Europe.

know nothing that is even comparable, except the work of the north transept of Rouen, described in the "Seven Lamps," p. 164; work of about the same date, and exactly the same plan; quatrefoils filled with grotesques, but somewhat less finished in execution, and somewhat less wild in imagination. I wrote down hastily, and in their own course, the subjects of some of the quatrefoils of Lyons; of which I here give the reader the sequence:—

1. Elephant and castle; less graphic than the St. Zeno one.
2. A huge head walking on two legs, turned backwards, hoofed; the head has a horn behind, with drapery over it, which ends in another head.
3. A boar hunt; the boar under a tree, very spirited.
4. A bird putting its head between its legs to bite its own tail, which ends in a head.
5. A dragon with a human head set on the wrong way.
6. St. Peter awakened by the angel in prison; full of spirit, the prison picturesque, with a trefoiled arch, the angel eager, St. Peter startled, and full of motion.
7. St. Peter led out by the angel.
8. The miraculous draught of fishes; fish and all, in the small space.
9. A large leaf, with two snails rampant, coming out of nautilus shells, with grotesque faces, and eyes at the ends of their horns.
10. A man with an axe striking at a dog's head, which comes out of a nautilus shell: the rim of the shell branches into a stem with two large leaves.
11. Martyrdom of St. Sebastian; his body very full of arrows.
12. Beasts coming to ark; Noah opening a kind of wicker cage.
13. Noah building the ark on shores.
14. A vineleaf with a dragon's head and tail, the one biting the other.
15. A man riding a goat, catching a flying devil.

16. An eel or muraena growing into a bunch of flowers, which turns into two wings.
17. A sprig of hazel, with nuts, thrown all around the quatrefoils with a squirrel in centre, apparently attached to the tree only by its enormous tail, richly furrowed into hair, and nobly sweeping.
18. Four hares fastened together by the ears, galloping in a circle. Mingled with these grotesques are many *sword* and *buckler* combats, the bucklers being round and conical like a hat; I thought the first I noticed, carried by a man at full gallop on horseback, had been a small umbrella.

This list of subjects may sufficiently illustrate the feverish character of the Northern Energy; but influencing the treatment of the whole there is also the Northern love of what is called the Grotesque, a feeling which I find myself, for the present, quite incapable either of analysing or defining, though we all have a distinct idea attached to the word: I shall try, however, in the next volume.

9. WOODEN CHURCHES OF THE NORTH.

I cannot pledge myself to this theory of the origin of the vaulting shaft, but the reader will find some interesting confirmations of it in Dahl's work on the wooden churches of Norway. The inside view of the church of Borgund shows the timber construction of one shaft run up through a crossing architrave, and continued into the clerestory; while the church of Urnes is in the exact form of a basilica; but the wall above the arches is formed of planks, with a strong upright above each capital. The passage quoted from Stephen Eddy's *Life of Bishop Wilfrid*, at p. 86 of Churton's "*Early English Church*," gives us one of the transformations of petrifications of the wooden Saxon churches. "At Ripon he built a new church of *polished stone*, with columns variously ornamented, and porches." Mr. Churton adds: "It was perhaps in bad imitation of the marble buildings he had seen in Italy,

that he washed the walls of this original York Minster, and made them 'whiter than snow.'"

10. CHURCH OF ALEXANDRIA.

The very cause which enabled the Venetians to possess themselves of the body of St. Mark, was the destruction of the church by the caliph for the *sake of its marbles*: the Arabs and Venetians, though bitter enemies, thus building on the same models; these in reverence for the destroyed church, and those with the very pieces of it. In the somewhat prolix account of the matter given in the *Notizie Storiche* (above quoted) the main points are, that "il Califa de' Saraceni, per fabbricarsi un Palazzo presso di Babilonia, aveva ordinato che dalle Chiese d' Cristiani si togliessero i più scelti marmi;" and that the Venetians, "videro sotto i loro occhi flagellarsi crudelmente un Cristiano per aver infranto un marmo." I heartily wish that the same kind of punishment were enforced to this day, for the same sin.

11. RENAISSANCE LANDSCAPE.

I am glad here to re-assert opinions which it has grieved me to be suspected of having changed. The calmer tone of the second volume of "Modern Painters," as compared with the first, induced, I believe, this suspicion, very justifiably, in the minds of many of its readers. The difference resulted, however, from the simple fact, that the first was written in great haste and indignation, for a special purpose and time;—the second, after I had got engaged, almost unawares, in inquiries which could not be hastily nor indignantly pursued; my opinions remaining then, and remaining now, altogether unchanged on the subject which led me into the discussion. And that no farther doubt of them may be entertained by any who may think them worth questioning, I shall here, once for all, express them in the plainest and fewest words I can. I think that J. M. W. Turner is not only the greatest (professed) landscape painter who ever lived, but that he has in him as much as would have furnished all the rest with such power as they had; and that if we put Nicolo Poussin, Salvator and

our own Gainsborough out of the group, he would cut up into Claudes, Cuyps, Ruysdaels, and such others, by uncounted bunches. I hope this is plainly and strongly enough stated. And farther, I like his later pictures, up to the year 1845, the best; and believe that those persons who only like his early pictures do not, in fact, like him at all. They do *not* like that which is essentially *his*. They like that in which he resembles other men; which he had learned from Louthembourg, Claude, or Wilson; that which is indeed his own, they do not care for. Not that there is not much of his own in his early works; they are all invaluable in their way; but those persons who can find no beauty in his strangest fantasy on the Academy walls, cannot distinguish the peculiarly Turner-esque characters of the earlier pictures. And, therefore, I again state here, that I think his pictures painted between the years 1830 and 1845 his greatest; and that his entire power is best represented by such pictures as the

Turner. Tintoret.

Massaccio.

John Bellini.

Albert Durer.

Giorgione.

Paul Veronese.

Titian.

Rubens.

Correggio.

Orcagna.

Benozzo Gozzoli.

Giotto.

Raffaello.

Perugino.

Temeraire, the Sun of Venice going to Sea, and others, painted exactly at the time when the public and the press were together loudest in abuse of him.

I desire, however, the reader to observe that I said, above, *professed* landscape painters, among whom, perhaps, I should hardly have put Gainsborough. The landscape of the great figure painters is often majestic in the highest degree, and Tintoret's especially shows exactly the same power and feeling as Turner's. If with Turner I were to rank the historical painters as landscapists, estimating rather the power they show, than the actual value of the landscape they produced, I should class those, whose landscapes I have studied, in some such order as this at the side of the page:— associating with the landscape of Perugino that of Francia and Angelico, and the other severe painters of religious subjects. I have put Turner and Tintoret side by side, not knowing

which is, in landscape, the greater ; I had nearly associated in the same manner the noble names of John Bellini and Albert Durer ; but Bellini must be put first, for his profound religious peace yet not separated from the other, if but that we might remember his kindness to him in Venice ; and it is well we should take note of it here, for it furnishes us with a most interesting confirmation of what was said in the text respecting the position of Bellini as the last of the religious painters of Venice. The following passage is quoted in Jackson's "Essay on Wood-engraving," from Albert Durer's Diary :

"I have many good friends among the Italians who warn me not to eat or drink with their painters, of whom several are my enemies, and copy my picture in the church, and others of mine, wherever they can find them, and yet they blame them, *and say they are not according to ancient art, and therefore not good.* Giovanni Bellini, however, has praised me highly to several gentlemen, and wishes to have something of my doing : he called on me himself, and requested that I would paint a picture for him, for which, he said, he would pay me well. People are all surprised that I should be so much thought of by a person of his reputation : he is very old, but is still the best painter of them all."

A choice little piece of description this, of the Renaissance painters, side by side with the good old Venetian, who was soon to leave them to their own ways. The Renaissance men are seen in perfection, envying, stealing, and lying, but without wit enough to lie to purpose.

12. ROMANIST MODERN ART.

It is of the highest importance, in these days, that Romanism should be deprived of the miserable influence which its pomp and picturesqueness have given it over the weak sentimentalism of the English people ; I call it a miserable influence, for of all motives to sympathy with the Church of Rome, this I unhesitatingly class as the basest : I can, in some measure, respect the other feelings which have been the beginnings of apostasy ; I can respect the desire for unity which would

reclaim the Romanist by love, and the distrust of his own heart which subjects the proselyte to priestly power ; I say I can respect these feelings, though I cannot pardon unprincipled submission to them, nor enough wonder at the infinite fatuity of the unhappy persons whom they have betrayed :—Fatuity, self-inflicted, and stubborn in resistance to God's Word and man's reason!—to talk of the authority of the Church, as if the Church were anything else than the whole company of Christian men, or were ever spoken of in Scripture* as other than a company to be taught and fed, not to teach and feed.—Fatuity ! to talk of a separation of Church and State, as if a Christian state, and every officer therein, were not necessarily a part of the Church,† and as if any state officer could do his duty without endeavoring to aid and promote religion, or any clerical officer do his duty without seeking for such aid and accepting it :—Fatuity ! to seek for the unity of a living body of truth and trust in God, with a dead body of lies and trust in wood, and thence to expect anything else than plague, and consumption by worms undying, for both. Blasphemy as well as fatuity ! to ask for any better interpreter of God's Word than God, or to expect knowledge of it in any other way than the plainly ordered way : if *any* man will do he shall know. But of all these fatuities, the basest is the being lured into the Romanist Church by the glitter of it, like larks into a trap by broken glass ; to be blown into a change of religion by the whine of an organ-pipe ; stitched into a new creed by gold threads on priests' petticoats ; jaugled into a change of conscience by the chimes of a belfry.

* Except in the single passage “tell it unto the Church,” which is simply the *extension* of what had been commanded before, i. e., tell the fault first “between thee and him,” then taking “with thee one or two more,” then, to all Christian men capable of hearing the cause : if he refuse to hear their common voice, “let him be unto thee as a heathen man and publican :” (But consider how Christ treated both.)

† One or two remarks on this subject, some of which I had intended to have inserted here, and others in Appendix 5, I have arranged in more consistent order, and published in a separate pamphlet, “Notes on the Construction of Sheep-folds,” for the convenience of readers interested in other architecture than that of Venetian palaces.

I know nothing in the shape of error so dark as this, no imbecility so absolute, no treachery so contemptible. I had hardly believed that it was a thing possible, though vague stories had been told me of the effect, on some minds, of mere scarlet and candles, until I came on this passage in Pugin's "Remarks on articles in the Rambler":—

"Those who have lived in want and privation are the best qualified to appreciate the blessing of plenty; thus, those who have been devout and sincere members of the separated portion of the English Church; who have prayed, and hoped, and loved, through all the poverty of the maimed rites which it has retained—to them does the realisation of all their longing desires appear truly ravishing. * * * Oh! then, what delight! what joy unspeakable! when one of the solemn piles is presented to them, in all its pristine life and glory!—the stoups are filled to the brim; the rood is raised on high; the screen glows with sacred imagery and rich device; the niches are filled; the altar is replaced, sustained by sculptured shafts, the relics of the saints repose beneath, the body of Our Lord is enshrined on its consecrated stone; the lamps of the sanctuary burn bright; the saintly portraitures in the glass windows shine all gloriously; and the albs hang in the oaken ambries, and the cope chests are filled with orphreyed baudelkins; and pix and pax, and chrismatory are there, and thurible, and cross."

One might have put this man under a pix, and left him, one should have thought; but he has been brought forward, and partly received, as an example of the effect of ceremonial splendor on the mind of a great architect. It is very necessary, therefore, that all those who have felt sorrow at this should know at once that he is not a great architect, but one of the smallest possible or conceivable architects; and that by his own account and setting forth of himself. Hear him:—

"I believe, as regards architecture, few men have been so unfortunate as myself. I have passed my life in thinking of fine things, studying fine things; designing fine things, and realising very poor ones. I have never had the chance of pro-

ducing a single fine ecclesiastical building, except my own church, where I am both paymaster and architect; but everything else, either for want of adequate funds or injudicious interference and control, or some other contingency, is more or less a failure. * * *

“St. George’s was spoilt by the very instructions laid down by the committee, that it was to hold 3000 people on the floor at a limited price; in consequence, height, proportion, everything, was sacrificed to meet these conditions. Nottingham was spoilt by the style being restricted to lancet,—a period well suited to a Cistercian abbey in a secluded vale, but very unsuitable for the centre of a crowded town. * * *

“Kirkham was spoilt through several hundred pounds being reduced on the original estimate; to effect this, which was a great sum in proportion to the entire cost, the area of the church was contracted, the walls lowered, tower and spire reduced, the thickness of walls diminished, and stone arches omitted.” (Remarks, &c., by A. Welby Pugin: Dolman, 1850.)

Is that so? Phidias can niche himself into the corner of a pediment, and Raffaele expatiate within the circumference of a clay platter; but Pugin is inexpressible in less than a cathedral? Let his ineffableness be assured of this, once for all, that no difficulty or restraint ever happened to a man of real power, but his power was the more manifested in the contending with, or conquering it; and that there is no field so small, no cranny so contracted, but that a great spirit can house and manifest itself therein. The thunder that smites the Alp into dust, can gather itself into the width of a golden wire. Whatever greatness there was in you, had it been Buonarroti’s own, you had room enough for it in a single niche: you might have put the whole power of it into two feet cube of Caen stone. St. George’s was not high enough for want of money? But was it want of money that made you put that blunt, overloaded, laborious ogee door into the side of it? Was it for lack of funds that you sunk the tracery of the parapet in its clumsy zigzags? Was it in parsimony that you buried its paltry pinnacles in that eruption of diseased crockets? or in pecuniary embarrassment that you set up the

belfry foolscaps, with the mimicry of dormer windows, which nobody can ever reach nor look out of? Not so, but in mere incapability of better things.

I am sorry to have to speak thus of any living architect ; and there is much in this man, if he were rightly estimated, which one might both regard and profit by. He has a most sincere love for his profession, a heartily honest enthusiasm for pices and piscinas ; and though he will never design so much as a pix or a piscina thoroughly well, yet better than most of the experimental architects of the day. Employ him by all means, but on small work. Expect no cathedrals from him ; but no one, at present, can design a better finial. That is an exceedingly beautiful one over the western door of St. George's ; and there is some spirited impishness and switching of tails in the supporting figures at the imposts. Only do not allow his good designing of finials to be employed as an evidence in matters of divinity, nor thence deduce the incompatibility of Protestantism and art. I should have said all that I have said above, of artistical apostasy, if Giotto had been now living in Florence, and if art were still doing all that it did once for Rome. But the grossness of the error becomes incomprehensible as well as unpardonable, when we look to what level of degradation the human intellect has sunk at this instant in Italy. So far from Romanism now producing anything greater in art, it cannot even preserve what has been given to its keeping. I know no abuses of precious inheritance half so grievous, as the abuse of all that is best in art wherever the Romanist priesthood gets possession of it. It amounts to absolute infatuation. The noblest pieces of mediæval sculpture in North Italy, the two griffins at the central (west) door of the cathedral of Verona, were daily permitted to be brought into service, when I was there in the autumn of 1849, by a washer-woman living in the Piazza, who tied her clothes-lines to their beaks : and the shafts of St. Mark's at Venice were used by a salesman of common caricatures to fasten his prints upon (Compare Appendix 25) ; and this in the face of the continually passing priests : while the quantity of noble art annually destroyed in altarpieces by candle-droppings, or perishing by

pure brutality of neglect, passes all estimate. I do not know, as I have repeatedly stated, how far the splendor of architecture, or other art, is compatible with the honesty and usefulness of religious service. The longer I live, the more I incline to severe judgment in this matter, and the less I can trust the sentiments excited by painted glass and colored tiles. But if there be indeed value in such things, our plain duty is to direct our strength against the superstition which has dishonored them ; there are thousands who might possibly be benefited by them, to whom they are now merely an offence, owing to their association with idolatrous ceremonies. I have but this exhortation for all who love them,—not to regulate their creeds by their taste in colors, but to hold calmly to the right, at whatever present cost to their imaginative enjoyment ; sure that they will one day find in heavenly truth a brighter charm than in earthly imagery, and striving to gather stones for the eternal building, whose walls shall be salvation, and whose gates shall be praise.

13. MR. FERGUSSON'S SYSTEM.

The reader may at first suppose this division of the attributes of buildings into action, voice, and beauty, to be the same division as Mr. Fergusson's, now well known, of their merits, into technic, æsthetic and phonetic.

But there is no connection between the two systems ; mine, indeed, does not profess to be a system, it is a mere arrangement of my subject, for the sake of order and convenience in its treatment : but, as far as it goes, it differs altogether from Mr. Fergusson's in these two following respects :—

The action of a building, that is to say its standing or consistence, depends on its good construction ; and the first part of the foregoing volume has been entirely occupied with the consideration of the constructive merit of buildings ; but construction is not their only technical merit. There is as much of technical merit in their expression, or in their beauty, as in their construction. There is no more mechanical or technical admirableness in the stroke of the painter who covers them

with fresco, than in the dexterity of the mason who cements their stones: there is just as much of what is technical in their beauty, therefore, as in their construction; and, on the other hand, there is often just as much intellect shown in their construction as there is in either their expression or decoration. Now Mr. Fergusson means by his "Phonetic" division, whatever expresses intellect: my constructive division, therefore, includes part of his phonetic: and my expressive and decorative divisions include part of his technical.

Secondly, Mr. Fergusson tries to make the same divisions fit the *subjects* of art, and art itself; and therefore talks of technic, æsthetic, and phonetic, *arts*, (or, translating the Greek,) of artful arts, sensitive arts, and talkative arts; but I have nothing to do with any division of the arts, I have to deal only with the merits of *buildings*. As, however, I have been led into reference to Mr. Fergusson's system, I would fain say a word or two to effect Mr. Fergusson's extrication from it. I hope to find in him a noble ally, ready to join with me in war upon affectation, falsehood, and prejudice, of every kind; I have derived much instruction from his most interesting work, and I hope for much more from its continuation; but he must disentangle himself from his system, or he will be strangled by it; never was anything so ingeniously and hopelessly wrong throughout; the whole of it is founded on a confusion of the instruments of man with his capacities.

Mr. Fergusson would have us take—

"First, man's muscular action or power." (Technics.)

"Secondly, those developments of sense *by which he does!!* as much as by his muscles." (Æsthetics.)

"Lastly, his intellect, or to confine this more correctly to its external action, *his power of speech!!!*" (Phonetics.)

Granting this division of humanity correct, or sufficient, the writer then most curiously supposes that he may arrange the arts as if there were some belonging to each division of man,—never observing that every art must be governed by, and addressed to, one division, and executed by another; executed by the muscular, addressed to the sensitive or intellectual; and that, to be an art at all, it must have in it work of the

one, and guidance from the other. If, by any lucky accident, he had been led to arrange the arts, either by their objects, and the things to which they are addressed, or by their means, and the things by which they are executed, he would have discovered his mistake in an instant. As thus:—

These arts are addressed to the,—Muscles!!

Senses,

Intellect;

or executed by,—Muscles,

Senses!!

Intellect.

Indeed it is true that some of the arts are in a sort addressed to the muscles, surgery for instance; but this is not among Mr Fergusson's technic, but his politic, arts! and all the arts may, in a sort, be said to be performed by the senses, as the senses guide both muscles and intellect in their work: but they guide them as they receive information, or are standards of accuracy, but not as in themselves capable of action. Mr. Fergusson is, I believe, the first person who has told us of senses that act or do, they having been hitherto supposed only to sustain or perceive. The weight of error, however, rests just as much in the original division of man, as in the endeavor to fit the arts to it. The slight omission of the soul makes a considerable difference when it begins to influence the final results of the arrangement.

Mr. Fergusson calls morals and religion "Politick arts" (as if religion were an art at all! or as if both were not as necessary to individuals as to societies); and therefore, forming these into a body of arts by themselves, leaves the best of the arts to do without the soul and the moral feeling as best they may. Hence "expression," or "phonetics," is of intellect only (as if men never expressed their *feelings*!); and then, strangest and worst of all, intellect is entirely resolved into talking! There can be no intellect but it must talk, and all talking must be intellectual. I believe people do sometimes talk without understanding; and I think the world would fare ill if they never understood without talking. The intel-

lect is an entirely silent faculty, and has nothing to do with parts of speech any more than the moral part has. A man may feel and know things without expressing either the feeling or knowledge; and the talking is a *muscular* mode of communicating the workings of the intellect or heart:—muscular, whether it be by tongue or by sign, or by carving or writing, or by expression of feature; so that to divide a man into muscular and talking parts, is to divide him into body in general, and tongue in particular, the endless confusion resulting from which arrangement is only less marvellous in itself, than the resolution with which Mr. Fergusson has worked through it, and in spite of it, up to some very interesting and suggestive truths; although starting with a division of humanity which does not in the least raise it above the brute, for a rattlesnake has his muscular, æsthetic, and talking part as much as man, only he talks with his tail, and says, “I am angry with you, and should like to bite you,” more laconically and effectively than any phonetic biped could, were he so minded. And, in fact, the real difference between the brute and man is not so much that the one has fewer means of expression than the other, as that it has fewer thoughts to express, and that we do not understand its expressions. Animals can talk to one another intelligibly enough when they have anything to say, and their captains have words of command just as clear as ours, and better obeyed. We have indeed, in watching the efforts of an intelligent animal to talk to a human being, a melancholy sense of its dumbness; but the fault is still in its intelligence, more than in its tongue. It has not wit enough to systematise its cries or signs, and form them into language.

But there is no end to the fallacies and confusions of Mr. Fergusson’s arrangement. It is a perfect entanglement of gun-cotton, and explodes into vacuity wherever one holds a light to it. I shall leave him to do so with the rest of it for himself, and should perhaps have left it to his own handling altogether, but for the intemperateness of the spirit with which he has spoken on a subject perhaps of all others demanding gentleness and caution. No man could more ear-

nestly have desired the changes lately introduced into the system of the University of Oxford than I did myself ; no man can be more deeply sensible than I of grievous failures in the practical working even of the present system : but I believe that these failures may be almost without exception traced to one source, the want of evangelical, and the excess of rubrical religion among the tutors ; together with such rustiness and stiffness as necessarily attend the continual operation of any intellectual machine. The fault is, at any rate, far less in the system than in the imperfection of its administration ; and had it been otherwise, the terms in which Mr. Fergusson speaks of it are hardly decorous in one who can but be imperfectly acquainted with its working. They are sufficiently answered by the structure of the essay in which they occur ; for if the high powers of mind which its author possesses had been subjected to the discipline of the schools, he could not have wasted his time on the development of a system which their simplest formulæ of logic would have shown him to be untenable.

Mr. Fergusson will, however, find it easier to overthrow his system than to replace it. Every man of science knows the difficulty of arranging a *reasonable* system of classification, in any subject, by any one group of characters ; and that the best classifications are, in many of their branches, convenient rather than reasonable : so that, to any person who is really master of his subject, many different modes of classification will occur at different times ; one of which he will use rather than another, according to the point which he has to investigate. I need only instance the three arrangements of minerals, by their external characters, and their positive or negative bases, of which the first is the most useful, the second the most natural, the third the most simple ; and all in several ways unsatisfactory.

But when the subject becomes one which no single mind can grasp, and which embraces the whole range of human occupation and enquiry, the difficulties become as great, and the methods as various, as the uses to which the classification might be put ; and Mr. Fergusson has entirely forgotten to

inform us what is the object to which his arrangements are addressed. For observe: there is one kind of arrangement which is based on the rational connection of the sciences or arts with one another; an arrangement which maps them out like the rivers of some great country, and marks the points of their junction, and the direction and force of their united currents; and this without assigning to any one of them a superiority above another, but considering them all as necessary members of the noble unity of human science and effort. There is another kind of classification which contemplates the order of succession in which they might most usefully be presented to a single mind, so that the given mind should obtain the most effective and available knowledge of them all: and, finally, the most usual classification contemplates the powers of mind which they each require for their pursuit, the objects to which they are addressed, or with which they are concerned; and assigns to each of them a rank superior or inferior, according to the nobility of the powers they require, or the grandeur of the subjects they contemplate.

Now, not only would it be necessary to adopt a different classification with respect to each of these great intentions, but it might be found so even to vary the order of the succession of sciences in the case of every several mind to which they were addressed; and that their rank would also vary with the power and specific character of the mind engaged upon them. I once heard a very profound mathematician remonstrate against the impropriety of Wordsworth's receiving a pension from government, on the ground that he was "only a poet." If the study of mathematics had always this narrowing effect upon the sympathies, the science itself would need to be deprived of the rank usually assigned to it; and there could be no doubt that, in the effect it had on the mind of this man, and of such others, it was a very contemptible science indeed. Hence, in estimating the real rank of any art or science, it is necessary for us to conceive it as it would be grasped by minds of every order. There are some arts and sciences which we underrate, because no one has risen to show us with what majesty they may be invested; and others

which we overrate, because we are blinded to their general meanness by the magnificence which some one man has thrown around them: thus, philology, evidently the most contemptible of all the sciences, has been raised to unjust dignity by Johnson.* And the subject is farther complicated by the question of usefulness; for many of the arts and sciences require considerable intellectual power for their pursuit, and yet become contemptible by the slightness of what they accomplish: metaphysics, for instance, exercising intelligence of a high order, yet useless to the mass of mankind, and, to its own masters, dangerous. Yet, as it has become so by the want of the true intelligence which its inquiries need, and by substitution of vain subtleties in its stead, it may in future vindicate for itself a higher rank than a man of common sense usually concedes to it.

Nevertheless, the mere attempt at arrangement must be useful, even where it does nothing more than develop difficulties. Perhaps the greatest fault of men of learning is their so often supposing all other branches of science dependent upon or inferior to their own best beloved branch; and the greatest deficiency of men comparatively unlearned, their want of perception of the connection of the branches with each other. He who holds the tree only by the extremities, can perceive nothing but the separation of its sprays. It must always be desirable to prove to those the equality of rank, to these the closeness of sequence, of what they had falsely supposed subordinate or separate. And, after such candid admission of the co-equal dignity of the truly noble arts and sciences, we may be enabled more justly to estimate the inferiority of those which indeed seem intended for the occupation of inferior powers and narrow capacities. In Appendix 14, following, some suggestions will be found as to the principles on which classification might be based; but the arrangement of all the arts is certainly not a work which

* Not, however, by Johnson's *testimony*: Vide *Adventurer*, No. 39. "Such operations as required neither celerity nor strength,—the low drudgery of collating copies, comparing authorities, *digesting dictionaries*, or accumulating compilations."

could with discretion be attempted in the Appendix to an essay on a branch of one of them.

14. DIVISIONS OF HUMANITY.

The reader will probably understand this part of the subject better if he will take the trouble briefly to consider the actions of the mind and body of man in the sciences and arts, which give these latter the relations of rank usually attributed to them.

It was above observed (Appendix 13) that the arts were generally ranked according to the nobility of the powers they require, that is to say, the quantity of the being of man which they engaged or addressed. Now their rank is not a very important matter as regards each other, for there are few disputes more futile than that concerning the respective dignity of arts, all of which are necessary and honorable. But it is a very important matter as regards themselves; very important whether they are practised with the devotion and regarded with the respect which are necessary or due to their perfection. It does not at all matter whether architecture or sculpture be the nobler art; but it matters much whether the thought is bestowed upon buildings, or the feeling is expressed in statues, which make either deserving of our admiration. It is foolish and insolent to imagine that the art which we ourselves practise is greater than any other; but it is wise to take care that in our own hands it is as noble as we can make it. Let us take some notice, therefore, in what degrees the faculties of man may be engaged in his several arts: we may consider the entire man as made up of body, soul, and intellect (Lord Lindsay, meaning the same thing, says inaccurately—sense, intellect, and spirit—forgetting that there is a moral sense as well as a bodily sense, and a spiritual body as well as a natural body, and so gets into some awkward confusion, though right in the main points). Then, taking the word soul as a short expression of the moral and responsible part of being, each of these three parts has a passive and active power. The body has senses and muscles;

the soul, feeling and resolution ; the intellect, understanding and imagination. The scheme may be put into tabular form, thus :—

	Passive or Receptive Part.	Active or Motive Part.
Body - - -	Senses.	Muscles.
Soul - - -	Feeling.	Resolution.
Intellect - - -	Understanding.	Imagination.

In this scheme I consider memory a part of understanding, and conscience I leave out, as being the voice of God in the heart, inseparable from the system, yet not an essential part of it. The sense of beauty I consider a mixture of the Senses of the body and soul.

Now all these parts of the human system have a reciprocal action on one another, so that the true perfection of any of them is not possible without some relative perfection of the others, and yet any one of the parts of the system may be brought into a morbid development, inconsistent with the perfection of the others. Thus, in a healthy state, the acuteness of the senses quickens that of the feelings, and these latter quicken the understanding, and then all the three quicken the imagination, and then all the four strengthen the resolution ; while yet there is a danger, on the other hand, that the encouraged and morbid feeling may weaken or bias the understanding, or that the over shrewd and keen understanding may shorten the imagination, or that the understanding and imagination together may take place of, or undermine, the resolution, as in Hamlet. So in the mere bodily frame there is a delightful perfection of the senses, consistent with the utmost health of the muscular system, as in the quick sight and hearing of an active savage : another false delicacy of the senses, in the Sybarite, consequent on their over indulgence, until the doubled rose-leaf is painful ; and this inconsistent with muscular perfection. Again ; there is a perfection of muscular action consistent with exquisite sense, as in that of the fingers of a musician or of a painter, in which the muscles are guided by the slightest feeling of the strings, or of the

pencil : another perfection of muscular action inconsistent with acuteness of sense, as in the effort of battle, in which a soldier does not perceive his wounds. So that it is never so much the question, what is the solitary perfection of a given part of the man, as what is its balanced perfection in relation to the whole of him : and again, the perfection of any single power is not merely to be valued by the mere rank of the power itself, but by the harmony which it indicates among the other powers. Thus, for instance, in an archer's glance along his arrow, or a hunter's raising of his rifle, there is a certain perfection of sense and finger which is the result of mere practice, of a simple bodily perfection ; but there is a farther value in the habit which results from the resolution and intellect necessary to the forming of it : in the hunter's raising of his rifle there is a quietness implying far more than mere practice,—implying courage, and habitual meeting of danger, and presence of mind, and many other such noble characters. So also in a musician's way of laying finger on his instrument, or a painter's handling of his pencil, there are many qualities expressive of the special sensibilities of each, operating on the production of the habit, besides the sensibility operating at the moment of action. So that there are three distinct stages of merit in what is commonly called mere bodily dexterity : the first, the dexterity given by practice, called command of tools or of weapons ; the second stage, the dexterity or grace given by character, as the gentleness of hand proceeding from modesty or tenderness of spirit, and the steadiness of it resulting from habitual patience coupled with decision, and the thousand other characters partially discernible, even in a man's writing, much more in his general handiwork ; and, thirdly, there is the perfection of action produced by the operation of *present* strength, feeling, or intelligence on instruments thus *previously* perfected, as the handling of a great painter is rendered more beautiful by his immediate care and feeling and love of his subject, or knowledge of it, and as physical strength is increased by strength of will and greatness of heart. Imagine, for instance, the difference in manner of fighting, and in actual muscular strength and en-

duration, between a common soldier, and a man in the circumstances of the Horatii, or of the temper of Leonidas.

Mere physical skill, therefore, the mere perfection and power of the body as an instrument, is manifested in three stages :

- First, Bodily power by practice ;
- Secondly, Bodily power by moral habit ;
- Thirdly, Bodily power by immediate energy ;

and the arts will be greater or less, *cæteris paribus*, according to the degrees of these dexterities which they admit. A smith's work at his anvil admits little but the first ; fencing, shooting, and riding, admit something of the second ; while the fine arts admit (merely through the channel of the bodily dexterities) an expression almost of the whole man.

Nevertheless, though the higher arts *admit* this higher bodily perfection, they do not all *require* it in equal degrees, but can dispense with it more and more in proportion to their dignity. The arts whose chief element is bodily dexterity, may be classed together as arts of the third order, of which the highest will be those which admit most of the power of moral habit and energy, such as riding and the management of weapons ; and the rest may be thrown together under the general title of handicrafts, of which it does not much matter which are the most honorable, but rather, which are the most necessary and least injurious to health, which it is not our present business to examine. Men engaged in the practice of these are called artizans, as opposed to artists, who are concerned with the fine arts.

The next step in elevation of art is the addition of the intelligences which have no connection with bodily dexterity ; as, for instance, in hunting, the knowledge of the habits of animals and their places of abode ; in architecture, of mathematics ; in painting, of harmonies of color ; in music, of those of sound ; all this pure science being joined with readiness of expedient in applying it, and with shrewdness in apprehension of difficulties, either present or probable.

It will often happen that intelligence of this kind is possessed

without bodily dexterity, or the need of it ; one man directing and another executing, as for the most part in architecture, war, and seamanship. And it is to be observed, also, that in proportion to the dignity of the art, the bodily dexterities needed even in its subordinate agents become less important, and are more and more replaced by intelligence ; as in the steering of a ship, the bodily dexterity required is less than in shooting or fencing, but the intelligence far greater : and so in war, the mere swordsmanship and marksmanship of the troops are of small importance in comparison with their disposition, and right choice of the moment of action. So that arts of this second order must be estimated, not by the quantity of bodily dexterity they require, but by the quantity and dignity of the knowledge needed in their practice, and by the degree of subtlety needed in bringing such knowledge into play. War certainly stands first in the general mind, not only as the greatest of the arts which I have called of the second order, but as the greatest of all arts. It is not, however, easy to distinguish the respect paid to the Power, from that rendered to the Art of the soldier ; the honor of victory being more dependent, in the vulgar mind, on its results, than its difficulties. I believe, however, that taking into consideration the greatness of the anxieties under which this art must be practised, the multitude of circumstances to be known and regarded in it, and the subtleties both of apprehension and stratagem constantly demanded by it, as well as the multiplicity of disturbing accidents and doubtful contingencies against which it must make provision on the instant, it must indeed rank as far the first of the arts of the second order ; and next to this great art of killing, medicine being much like war in its stratagems and watchings against its dark and subtle death-enemy.

Then the arts of the first order will be those in which the Imaginative part of the intellect and the Sensitive part of the soul are joined : as poetry, architecture, and painting ; these forming a kind of cross, in their part of the scheme of the human being, with those of the second order, which wed the Intelligent part of the intellect and Resolute part of the soul.

But the reader must feel more and more, at every step, the impossibility of classing the arts themselves, independently of the men by whom they are practised ; and how an art, low in itself, may be made noble by the quantity of human strength and being which a great man will pour into it ; and an art, great in itself, be made mean by the meanness of the mind occupied in it. I do not intend, when I call painting an art of the first, and war an art of the second, order, to class Dutch landscape painters with good soldiers ; but I mean, that if from such a man as Napoleon we were to take away the honor of all that he had done in law and civil government, and to give him the reputation of his soldiership only, his name would be less, if justly weighed, than that of Buonarroti, himself a good soldier also, when need was. But I will not endeavor to pursue the inquiry, for I believe that of all the arts of the first order it would be found that all that a man has, or is, or can be, he can fully express in them, and give to any of them, and find it not enough.

15. INSTINCTIVE JUDGMENTS.

The same rapid judgment which I wish to enable the reader to form of architecture, may in some sort also be formed of painting, owing to the close connection between execution and expression in the latter ; as between structure and expression in the former. We ought to be able to tell good painting by a side glance as we pass along a gallery ; and, until we can do so, we are not fit to pronounce judgment at all : not that I class this easily visible excellence of painting with the great expressional qualities which time and watchfulness only unfold. I have again and again insisted on the supremacy of these last and shall always continue to do so. But I perceive a tendency among some of the more thoughtful critics of the day to forget that the business of a painter is to *paint*, and so altogether to despise those men, Veronese and Rubens for instance, who were painters, par excellence, and in whom the expressional qualities are subordinate. Now it is well, when we have strong moral or poetical feeling manifested in painting, to mark this as the best part of the work ; but it is not

well to consider as a thing of small account, the painter's language in which that feeling is conveyed ; for if that language be not good and lovely, the man may indeed be a just moralist or a great poet, but he is not a *painter*, and it was wrong of him to paint. He had much better put his morality into sermons, and his poetry into verse, than into a language of which he was not master. And this mastery of the language is that of which we should be cognizant by a glance of the eye ; and if that be not found, it is wasted time to look farther : the man has mistaken his vocation, and his expression of himself will be cramped by his awkward efforts to do what he was not fit to do. On the other hand, if the man be a painter indeed, and have the gift of colors and lines, what is in him will come from his hand freely and faithfully ; and the language itself is so difficult and so vast, that the mere possession of it argues the man is great, and that his works are worth reading. So that I have never yet seen the case in which this true artistical excellence, visible by the eye-glance, was not the index of some true expressional worth in the work. Neither have I ever seen a good expressional work without high artistical merit : and that this is ever denied is only owing to the narrow view which men are apt to take both of expression and of art ; a narrowness consequent on their own especial practice and habits of thought. A man long trained to love the monk's visions of Fra Angelico, turns in proud and ineffable disgust from the first work of Rubens which he encounters on his return across the Alps. But is he right in his indignation ? He has forgotten, that while Angelico prayed and wept in his *olive shade*, there was different work doing in the dank fields of Flanders ;—wild seas to be banked out ; endless canals to be dug, and boundless marshes to be drained ; hard ploughing and harrowing of the frosty clay ; careful breeding of stout horses and fat cattle ; close setting of brick walls against cold winds and snow ; much hardening of hands and gross stoutening of bodies in all this ; gross jovialities of harvest homes and Christmas feasts, which were to be the reward of it ; rough affections, and sluggish imagination ; fleshy, substantial, ironshod humanities, but

humanities still ; humanities which God had his eye upon, and which won, perhaps, here and there, as much favor in his sight as the wasted aspects of the whispering monks of Florence (Heaven forbid it should not be so, since the most of us cannot be monks, but must be ploughmen and reapers still). And are we to suppose there is no nobility in Rubens' masculine and universal sympathy with all this, and with his large human rendering of it, Gentleman though he was, by birth, and feeling, and education, and place ; and, when he chose, lordly in conception also ? He had his faults, perhaps great and lamentable faults, though more those of his time and his country than his own ; he has neither cloister breeding nor boudoir breeding, and is very unfit to paint either in missals or annuals ; but he has an open sky and wide-world breeding in him, that we may not be offended with, fit alike for king's court, knight's camp, or peasant's cottage. On the other hand, a man trained here in England, in our Sir Joshua school, will not and cannot allow that there is any art at all in the technical work of Angelico. But he is just as wrong as the other. Fra Angelico is as true a master of the art necessary to his purposes, as Rubens was of that necessary for his. We have been taught in England to think there can be no virtue but in a loaded brush and rapid hand ; but if we can shake our common sense free of such teaching, we shall understand that there is art also in the delicate point and in the hand which trembles as it moves ; not because it is more liable to err, but because there is more danger in its error, and more at stake upon its precision. The art of Angelico, both as a colorist and a draughtsman, is consummate ; so perfect and beautiful, that his work may be recognised at any distance by the rainbow-play and brilliancy of it : However closely it may be surrounded by other works of the same school, glowing with enamel and gold, Angelico's may be told from them at a glance, like so many huge pieces of opal lying among common marbles. So again with Giotto ; the Arena chapel is not only the most perfect expressional work, it is the prettiest piece of wall decoration and fair color, in North Italy.

Now there is a correspondence of the same kind between the technical and expressional parts of architecture ;—not a true or entire correspondence, so that when the expression is best, the building must be also best ; but so much of correspondence as that good building is necessary to good expression, comes before it, and is to be primarily looked for : and the more, because the manner of building is capable of being determinately estimated and classed ; but the expressional character not so : we can at once determine the true value of technical qualities, we can only approximate to the value of expressional qualities : and besides this, the looking for the technical qualities first will enable us to cast a large quantity of rubbish aside at once, and so to narrow the difficult field of inquiry into expression : we shall get rid of Chinese pagodas and Indian temples, and Renaissance Palladianisms, and Alhambra stucco and filigree, in one great rubbish heap ; and shall not need to trouble ourselves about their expression, or anything else concerning them. Then taking the buildings which have been rightly put together, and which show common sense in their structure, we may look for their farther and higher excellences ; but on those which are absurd in their first steps we need waste no time.

16. STRENGTH OF SHAFTS.

I could have wished, before writing this chapter, to have given more study to the difficult subject of the strength of shafts of different materials and structure ; but I cannot enter into every inquiry which general criticism might suggest, and this I believe to be one which would have occupied the reader with less profit than many others : all that is necessary for him to note is, that the great increase of strength gained by a tubular form in iron shafts, of given solid contents, is no contradiction to the general principle stated in the text, that the strength of materials is most available when they are most concentrated. The strength of the tube is owing to certain properties of the arch formed by its sides, not to the dispersion of its materials : and the principle is altogether inapplica-

ble to stone shafts. No one would think of building a pillar of a succession of sandstone rings ; however strong it might be, it would be still stronger filled up, and the substitution of such a pillar for a solid one of the same contents would lose too much space ; for a stone pillar, even when solid, must be quite as thick as is either graceful or convenient, and in modern churches is often too thick as it is, hindering sight of the preacher, and checking the sound of his voice.

17. ANSWER TO MR. GARBETT.

Some three months ago, and long after the writing of this passage, I met accidentally with Mr. Garbett's elementary Treatise on Design. (Weale, 1850.) If I had cared about the reputation of originality, I should have been annoyed—and was so, at first, on finding Mr. Garbett's illustrations of the subject exactly the same as mine, even to the choice of the elephant's foot for the parallel of the Doric pillar : I even thought of omitting, or re-writing, great part of the chapter, but determined at last to let it stand. I am striving to speak plain truths on many simple and trite subjects, and I hope, therefore, that much of what I say has been said before, and am quite willing to give up all claim to originality in any reasoning or assertion whatsoever, if any one cares to dispute it. I desire the reader to accept what I say, not as mine, but as the truth, which may be all the world's, if they look for it. If I remember rightly, Mr. Frank Howard promised at some discussion respecting the "Seven Lamps," reported in the "Builder," to pluck all my borrowed feathers off me ; but I did not see the end of the discussion, and do not know to this day how many feathers I have left : at all events the elephant's foot must belong to Mr. Garbett, though, strictly speaking, neither he nor I can be quite justified in using it, for an elephant in reality stands on tiptoe ; and this is by no means the expression of a Doric shaft. As, however, I have been obliged to speak of this treatise of Mr. Garbett's, and desire also to recommend it as of much interest and utility in its statements of fact, it is impossible for me to pass altogether without no

lice, as if unanswerable, several passages in which the writer has objected to views stated in the "Seven Lamps." "I should at any rate have noticed the passage quoted above, (Chap. 30th,) which runs counter to the spirit of all I have ever written, though without referring to me; but the references to the "Seven Lamps" I should not have answered, unless I had desired, generally, to recommend the book, and partly also, because they may serve as examples of the kind of animadversion which the "Seven Lamps" had to sustain from architects, very generally; which examples being once answered, there will be little occasion for my referring in future to other criticisms of the kind.

The first reference to the "Seven Lamps" is in the second page, where Mr. Garbett asks a question, "Why are not convenience and stability enough to constitute a fine building?"—which I should have answered shortly by asking another, "Why we have been made men, and not bees nor termites:" but Mr. Garbett has given a very pretty, though partial, answer to it himself, in his 4th to 9th pages,—an answer which I heartily beg the reader to consider. But, in page 12, it is made a grave charge against me, that I use the words beauty and ornament interchangeably. I do so, and ever shall; and so, I believe, one day, will Mr. Garbett himself; but not while he continues to head his pages thus:—"Beauty not dependent on ornament, *or superfluous* features." What right has he to assume that ornament, rightly so called, ever was, or can be, superfluous? I have said before, and repeatedly in other places, that the most beautiful things are the most useless; I never said superfluous. I said useless in the well-understood and usual sense, as meaning, inapplicable to the service of the body. Thus I called peacocks and lilies useless; meaning, that roast peacock was unwholesome (taking Juvenal's word for it), and that dried lilies made bad hay: but I do not think peacocks superfluous birds, nor that the world could get on well without its lilies. Or, to look closer, I suppose the peacock's blue eyes to be very useless to him; not dangerous indeed, as to their first master, but of small service, yet I do not think there is a superfluous eye in all his

tail: and for lilies, though the great King of Israel was not "arrayed" like one of them, can Mr. Garbett tell us which are their superfluous leaves? Is there no Diogenes among lilies? none to be found content to drink dew, but out of silver? The fact is, I never met with the architect yet who did not think ornament meant a thing to be bought in a shop and pinned on, or left off, at architectural toilets, as the fancy seized them, thinking little more than many women do of the other kind of ornament—the only true kind,—St. Peter's kind,—“Not that outward adorning, but the inner—of the heart.” I do not mean that architects cannot conceive this better ornament, but they do not understand that it is the *only* ornament; that *all* architectural ornament is this, and nothing but this; that a noble building never has any extraneous or superfluous ornament; that all its parts are necessary to its loveliness, and that no single atom of them could be removed without harm to its life. You do not build a temple and then dress it.* You create it in its loveliness, and leave it, as her Maker left Eve. Not unadorned, I believe, but so well adorned as to need no feather crowns. And I use the words ornament and beauty interchangeably, in order that architects may understand this: I assume that their building is to be a perfect creature capable of nothing less than it has, and needing nothing more. It may, indeed, receive additional decoration afterwards, exactly as a woman may gracefully put a bracelet on her arm, or set a flower in her hair: but that additional decoration is *not* the *architecture*. It is of curtains, pictures, statues, things that may be taken away from the building, and not hurt it. What has the architect to do with these? He has only to do with what is part of the building itself, that is to say, its own inherent beauty. And because Mr. Garbett does not understand or acknowledge this, he is led on from error to error; for we next find him endeavoring to define beauty as distinct from ornament, and saying that “Positive beauty may be produced by a studious collation of whatever will

* We have done so—theoretically; just as one would reason on the human form from the bones outwards: but the Architect of human form frames all at once—bone and flesh.

(display design, order, and congruity." (p. 14.) Is that so? There is a highly studious collation of whatever will display design, order, and congruity, in a skull, is there not?—yet small beauty. The nose is a decorative feature,—yet slightly necessary to beauty, it seems to me; now, at least, for I once thought I must be wrong in considering a skull disagreeable. I gave it fair trial: put one on my bedroom chimney-piece, and looked at it by sunrise every morning, and by moonlight every night, and by all the best lights I could think of, for a month, in vain. I found it as ugly at last as I did at first. So, also, the hair is a decoration, and its natural curl is of little use; but can Mr. Garbett conceive a bald beauty; or does he prefer a wig, because that is a "*studious collation*" of whatever will produce design, order, and congruity? So the flush of the cheek is a decoration,—God's painting of the temple of his spirit,—and the redness of the lip; and yet poor Viola thought it beauty truly blent; and I hold with her.

I have answered enough to this count.

The second point questioned is my assertion, "Ornament cannot be overcharged if it is good, and is always overcharged when it is bad." To which Mr. Garbett objects in these terms: "I must contend, on the contrary, that the very best ornament may be overcharged by being misplaced."

A short sentence with two mistakes in it.

First. Mr. Garbett cannot get rid of his unfortunate notion that ornament is a thing to be manufactured separately, and fastened on. He supposes that an ornament may be called good in itself, in the stonemason's yard, or in the ironmonger's shop: Once for all, let him put this idea out of his head. We may say of a thing, considered separately, that it is a pretty thing; but before we can say it is a good ornament, we must know what it is to adorn, and how. As, for instance, a ring of gold is a pretty thing; it is a good ornament on a woman's finger; not a good ornament hung through her under lip. A hollyhock, seven feet high, would be a good ornament for a cottage-garden; not a good ornament for a lady's head-dress. Might not Mr. Garbett have seen this without my showing? and that, therefore, when I said "*good*" ornament, I said

“well-placed” ornament, in one word, and that, also, when Mr. Garbett says “it may be overcharged by being misplaced,” he merely says it may be overcharged by being *bad*.

Secondly. But, granted that ornament *were* independent of its position, and might be pronounced good in a separate form, as books are good, or men are good,—Suppose I had written to a student in Oxford, “You cannot have too many books, if they be good books;” and he had answered me, “Yes, for if I have many, I have no place to put them in but the coal-cellar.” Would that in anywise affect the general principle that he could not have too many books?

Or suppose he had written, “I must not have too many, they confuse my head.” I should have written back to him: “Don’t buy books to put in the coal-hole, nor read them if they confuse your head; you cannot have too many, if they be good: but if you are too lazy to take care of them, or too dull to profit by them, you are better without them.”

Exactly in the same tone, I repeat to Mr. Garbett, “You cannot have too much ornament, if it be good: but if you are too indolent to arrange it, or too dull to take advantage of it, assuredly you are better without it.”

The other points bearing on this question have already been stated in the close of the 21st chapter.

The third reference I have to answer, is to my repeated assertion, that the evidence of manual labor is one of the chief sources of value in ornament, (“Seven Lamps,” p. 56, “Modern Painters,” § 1, Chap. III.) to which objection is made in these terms: “We must here warn the reader against a remarkable error of Ruskin. The value of ornaments in architecture depends *not in the slightest degree* on the *manual labor* they contain. If it did, the finest ornaments ever executed would be the stone chains that hang before certain Indian rock-temples.” Is that so? Hear a parallel argument. “The value of the Cornish mines depends *not in the slightest degree* on the quantity of copper they contain. If it did, the most valuable things ever produced would be copper saucepans.” It is hardly worth my while to answer this; but, lest any of my readers should be confused by the objection, and as I hold

the fact to be of great importance, I may re-state it for them with some explanation.

Observe, then, the appearance of labor, that is to say, the evidence of the past industry of man, is always, in the abstract, intensely delightful: man being meant to labor, it is delightful to see that he *has* labored, and to read the record of his active and worthy existence.

The evidence of labor becomes painful only when it is a *sign of Evil greater, as Evil, than the labor is great, as Good*. As, for instance, if a man has labored for an hour at what might have been done by another man in a moment, this evidence of his labor is also evidence of his weakness; and this weakness is greater in rank of evil, than his industry is great in rank of good.

Again, if a man have labored at what was not worth accomplishing, the signs of his labor are the signs of his folly, and his folly dishonors his industry; we had rather he had been a wise man in rest than a fool in labor.

Again, if a man have labored without accomplishing anything, the signs of his labor are the signs of his disappointment; and we have more sorrow in sympathy with his failure, than pleasure in sympathy with his work.

Now, therefore, in ornament, whenever labor replaces what was better than labor, that is to say, skill and thought; wherever it substitutes itself for these, or *negatives these by its existence*, then it is positive evil. Copper is an evil when it alloys gold, or poisons food: not an evil, as copper; good in the form of pence, seriously objectionable when it occupies the room of guineas. Let Danaë cast it out of her lap, when the gold comes from heaven; but let the poor man gather it up carefully from the earth.

Farther, the evidence of labor is not only a good when added to other good, but the utter absence of it destroys good in human work. It is only good for God to create without toil; that which man can create without toil is worthless: machine ornaments are no ornaments at all. Consider this carefully, reader: I could illustrate it for you endlessly; but you feel it yourself every hour of your existence. And if you do not

know that you feel it, take up, for a little time, the trade which of all manual trades has been most honored: be for once a carpenter. Make for yourself a table or a chair, and see if you ever thought any table or chair so delightful, and what strange beauty there will be in their crooked limbs.

I have not noticed any other animadversions on the "Seven Lamps" in Mr. Garbett's volume; but if there be more, I must now leave it to his own consideration, whether he may not, as in the above instances, have made them incautiously: I may, perhaps, also be permitted to request other architects, who may happen to glance at the preceding pages, not immediately to condemn what may appear to them false in general principle. I must often be found deficient in technical knowledge; I may often err in my statements respecting matters of practice or of special law. But I do not write thoughtlessly respecting principles; and my statements of these will generally be found worth reconnoitring before attacking. Architects, no doubt, fancy they have strong grounds for supposing me wrong when they seek to invalidate my assertions. Let me assure them, at least, that I mean to be their friend, although they may not immediately recognise me as such. If I could obtain the public ear, and the principles I have advocated were carried into general practice, porphyry and serpentine would be given to them instead of limestone and brick; instead of tavern and shop-fronts they would have to build goodly churches and noble dwelling-houses; and for every stunted Grecism and stucco Romanism, into which they are now forced to shape their palsied thoughts, and to whose crumbling plagiarisms they must trust their doubtful fame, they would be asked to raise whole streets of bold, and rich, and living architecture, with the certainty in their hearts of doing what was honorable to themselves, and good for all men.

Before I altogether leave the question of the influence of labor on architectural effect, the reader may expect from me a word or two respecting the subject which this year must be interesting to all—the applicability, namely, of glass and iron to architecture in general, as in some sort exemplified by the Crystal Palace.

It is thought by many that we shall forthwith have great part of our architecture in glass and iron, and that new forms of beauty will result from the studied employment of these materials.

It may be told in a few words how far this is possible ; how far eternally impossible.

There are two means of delight in all productions of art—color and form.

The most vivid conditions of color attainable by human art are those of works in glass and enamel, but not the most perfect. The best and noblest coloring possible to art is that attained by the touch of the human hand on an opaque surface, upon which it can command any tint required, without subjection to alteration by fire or other mechanical means. No color is so noble as the color of a good painting on canvas or gesso.

This kind of color being, however, impossible, for the most part, in architecture, the next best is the scientific disposition of the natural colors of stones, which are far nobler than any abstract hues producible by human art.

The delight which we receive from glass painting is one altogether inferior, and in which we should degrade ourselves by over indulgence. Nevertheless, it is possible that we may raise some palaces like Aladdin's with colored glass for jewels, which shall be new in the annals of human splendor, and good in their place ; but not if they superseded nobler edifices.

Now, color is producible either on opaque or in transparent bodies : but form is only expressible, in its perfection, on opaque bodies, without lustre.

This law is imperative, universal, irrevocable. No perfect or refined form can be expressed except in opaque and lustreless matter. You cannot see the form of a jewel, nor, in any perfection, even of a cameo or bronze. You cannot perfectly see the form of a humming-bird, on account of its burnishing ; but you can see the form of a swan perfectly. No noble work in form can ever, therefore, be produced in transparent or lustrous glass or enamel. All noble architecture depends

for its majesty on its form : therefore you can never have any noble architecture in transparent or lustrous glass or enamel. Iron is, however, opaque ; and both it and opaque enamel may, perhaps, be rendered quite lustreless ; and, therefore, fit to receive noble form.

Let this be thoroughly done, and both the iron and enamel made fine in paste or grain, and you may have an architecture as noble as cast or struck architecture even can be : as noble, therefore, as coins can be, or common cast bronzes, and such other multiplicable things ;*—eternally separated from all good and great things by a gulph which not all the tubular bridges nor engineering of ten thousand nineteenth centuries cast into one great bronze-foreheaded century, will ever overpass one inch of. All art which is worth its room in this world, all art which is not a piece of blundering refuse, occupying the foot or two of earth which, if unencumbered by it, would have grown corn or violets, or some better thing, is *art which proceeds from an individual mind, working through instruments which assist, but do not supersede, the muscular action of the human hand, upon the materials which most tenderly receive, and most securely retain, the impressions of such human labor.*

And the value of every work of art is exactly in the ratio of the quantity of humanity which has been put into it, and legibly expressed upon it for ever :—

First, of thought and moral purpose ;

Secondly, of technical skill ;

Thirdly, of bodily industry.

* Of course mere multiplicability, as of an engraving, does not diminish the intrinsic value of the work ; and if the casts of sculpture could be as sharp as the sculpture itself, they would hold to it the relation of value which engravings hold to paintings. And, if we choose to have our churches all alike, we might cast them all in bronze—we might actually coin churches, and have mints of Cathedrals. It would be worthy of the spirit of the century to put milled edges for mouldings, and have a popular currency of religious subjects : a new cast of nativities every Christmas. I have not heard this contemplated, however, and I speak, therefore, only of the results which I believe are contemplated, as attainable by mere mechanical applications of glass and iron.

The quantity of bodily industry which that Crystal Palace expresses is very great. So far it is good.

The quantity of thought it expresses is, I suppose, a single and very admirable thought of Mr. Paxton's, probably not a bit brighter than thousands of thoughts which pass through his active and intelligent brain every hour,—that it might be possible to build a greenhouse larger than ever greenhouse was built before. This thought, and some very ordinary algebra, are as much as all that glass can represent of human intellect. “But one poor half-pennyworth of bread to all this intolerable deal of sack.” Alas!

“The earth hath bubbles as the water hath :
And this is of them.”

18. EARLY ENGLISH CAPITALS.

The depth of the cutting in some of the early English capitals is, indeed, part of a general system of attempts at exaggerated force of effect, like the “*black touches*” of second-rate draughtsmen which I have noticed as characteristic of nearly all northern work, associated with the love of the grotesque : but the main section of the capital is indeed a dripstone rolled round, as above described ; and dripstone sections are continually found in northern work, where not only they cannot increase force of effect, but are entirely invisible except on close examination ; as, for instance, under the uppermost range of stones of the foundation of Whitehall, or under the slope of the restored base of All Souls College, Oxford, under the level of the eye. I much doubt if any of the Fellows be aware of its existence.

Many readers will be surprised and displeased by the disparagement of the early English capital. That capital has, indeed, one character of considerable value ; namely, the boldness with which it stops the mouldings which fall upon it, and severs them from the shaft, contrasting itself with the multiplicity of their vertical lines. Sparingly used, or seldom seen, it is thus, in its place, not unpleasing ; and we English love it from association, it being always found in connection with our

purest and loveliest Gothic arches, and never in multitudes large enough to satiate the eye with its form. The reader who sits in the Temple church every Sunday, and sees no architecture during the week but that of Chancery Lane, may most justifiably quarrel with me for what I have said of it. But if every house in Fleet Street or Chancery Lane were Gothic, and all had early English capitals, I would answer for his making peace with me in a fortnight.

19. TOMBS NEAR ST. ANASTASIA.

Whose they are, is of little consequence to the reader or to me, and I have taken no pains to discover; their value being not in any evidence they bear respecting dates, but in their intrinsic merit as examples of composition. Two of them are within the gate, one on the top of it, and this latter is on the whole the best, though all are beautiful; uniting the intense northern energy in their figure sculpture with the most serene classical restraint in their outlines, and unaffected, but masculine simplicity of construction.

I have not put letters to the diagram of the lateral arch at page 158, in order not to interfere with the clearness of the curves, but I shall always express the same points by the same letters, whenever I have to give measures of arches of this simple kind, so that the reader need never have the diagrams lettered at all. The base or span of the centre arch will always be ab ; its vertex will always be V ; the points of the cusps will be cc ; pp will be the bases of perpendiculars let fall from V and c on ab ; and d the base of a perpendicular from the point of the cusp to the arch line. Then ab will always be a span of the arch, Vp its perpendicular height, Va the chord of its side arcs, dc the depth of its cusps, cc the horizontal interval between the cusps, ac the length of the chord of the lower arc of the cusp, Vc the length of the chord of the upper arc of the cusp, (whether continuous or not,) and cp the length of a perpendicular from the point of the cusp on ab .

Of course we do not want all these measures for a single arch, but it often happens that some of them are attainable

more easily than others ; some are often unattainable altogether, and it is necessary therefore to have expressions for whichever we may be able to determine.

Vp or Va , ab , and dc are always essential ; then either c and Vc or cc and cp : when I have my choice, I always take ab , Vp , dc , cc , and cp , but cp is not to be generally obtained so accurately as the cusp arcs.

The measures of the present arch are :

	Ft.	In.
ab ,	3	8
Vp ,	4	0
Vc ,	2	$4\frac{1}{2}$
ac ,	2	$0\frac{1}{4}$
dc ,	0	$3\frac{1}{2}$

20. SHAFTS OF DUCAL PALACE.

The shortness of the thicker ones at the angles is induced by the greater depth of the enlarged capitals : thus the 36th shaft is 10 ft. $4\frac{1}{3}$ in. in circumference at its base, and 10 ,, $0\frac{1}{2}$ * in circumference under the fillet of its capital ; but it is only 6 ,, $1\frac{3}{4}$ high, while the minor intermediate shafts, of which the thickest is 7 ,, 8 round at the base, and 7 ,, 4 under capital, are yet on the average 7 ,, 7 high. The angle shaft towards the sea (the 18th) is nearly of the proportions of the 36th, and there are three others, the 15th, 24th, and 26th, which are thicker than the rest, though not so thick as the angle ones. The 24th and 26th have both party walls to bear, and I imagine the 15th must in old time have carried another, reaching across what is now the Sala del Gran Consiglio.

They measure respectively round at the base,

The 15th,	8	2
24th,	9	$6\frac{1}{2}$
26th,	8	$0\frac{1}{2}$

* I shall often have occasion to write measures in the current text, therefore the reader will kindly understand that whenever they are thus written, 2 ,, 2, with double commas between, the first figures stand for English feet, the second for English inches.

The other pillars towards the sea, and those to the 27th inclusive of the Piazzetta, are all seven feet round at the base, and then there is a most curious and delicate crescendo of circumference to the 36th, thus :

The 28th, 7 ,, 3	The 33rd, 7 ,, 6
29th, 7 ,, 4	34th, 7 ,, 8
30th, 7 ,, 6	35th, 7 ,, 8
31st, 7 ,, 7	36th, 10 ,, 4½
32nd 7 ,, 5	

The shafts of the upper arcade, which are above these thicker columns, are also thicker than their companions, measuring on the average, 4 ,, 8½ in circumference, while those of the sea façade, except the 29th, average 4 ,, 7½ in circumference. The 29th, which is of course above the 15th of the lower story, is 5 ,, 5 in circumference, which little piece of evidence will be of no small value to us by-and-by. The 35th carries the angle of the palace, and is 6 ,, 0 round. The 47th, which comes above the 24th and carries the party wall of the Sala del Gran Consiglio, is strengthened by a pilaster ; and the 51st, which comes over the 26th, is 5 ,, 4½ round, or nearly the same as the 29th ; it carries the party wall of the Sala del Scrutinio ; a small room containing part of St. Mark's library, coming between the two saloons ; a room which, in remembrance of the help I have received in all my inquiries from the kindness and intelligence of its usual occupant, I shall never easily distinguish otherwise than as " Mr. Lorenzi's." *

I may as well connect with these notes respecting the arcades of the Ducal Palace, those which refer to Plate XIV., which represents one of its spandrils. Every spandril of the lower arcade was intended to have been occupied by an ornament resembling the one given in that plate. The mass of the building being of Istrian stone, a depth of about two inches is left within the mouldings of the arches, rough hewn, to

* I cannot suffer this volume to close without also thanking my kind friend, Mr. Rawdon Brown, for help given me in a thousand ways during my stay in Venice : but chiefly for his direction to passages elucidatory of my subject in the MSS. of St. Mark's library.

receive the slabs of fine marble composing the patterns. I cannot say whether the design was ever completed, or the marbles have been since removed, but there are now only two spandrils retaining their fillings, and vestiges of them in a third. The two complete spandrils are on the sea façade, above the 3rd and 10th capitals (*vide* method of numbering, Chap. I., page 44); that is to say, connecting the 2nd arch with the 3rd, and the 9th with the 10th. The latter is the one given in Plate XIV. The white portions of it are all white marble, the dentil band surrounding the circle is in coarse sugary marble, which I believe to be Greek, and never found in Venice to my recollection, except in work at least anterior to the fifteenth century. The shaded fields charged with the three white triangles are of red Verona marble; the inner disc is green serpentine, and the dark pieces of the radiating leaves are grey marble. The three triangles are equilateral. The two uppermost are 1, 5 each side, and the lower 1, 2.

The extreme diameter of the circle is 3, $10\frac{1}{2}$; its field is slightly raised above the red marbles, as shown in the section at A, on the left. *A a* is part of the red marble field; *a b* the section of the dentil moulding let into it; *b c* the entire breadth of the rayed zone, represented on the other side of the spandrill by the line *C f*; *c d* is the white marble band let in, with the dog-tooth on the face of it; *b c* is $7\frac{3}{4}$ inches across; *c d* $3\frac{3}{4}$; and at B are given two joints of the dentil (mentioned above, in the chapter on dentils, as unique in Venice) of their actual size. At C is given one of the inlaid leaves; its measure being (in inches) *C f* $7\frac{3}{4}$; *C h* $\frac{3}{4}$; *f g* $\frac{3}{4}$; *f e* $4\frac{3}{4}$, the base of the smaller leaves being of course *f e* — *f g* = 4. The pattern which occupies the other spandrill is similar, except that the field *b c*, instead of the intersecting arcs, has only triangles of grey marble, arranged like rays, with their bases towards the centre. There being twenty round the circle, the reader can of course draw them for himself; they being isosceles, touching the dentil with their points, and being in contact at their bases: it has lost its central boss. The marbles are, in both, covered with a rusty

coating, through which it is excessively difficult to distinguish the colors (another proof of the age of the ornament). But the white marbles are certainly, in places (except only the sugary dentil), veined with purple, and the grey seem warmed with green.

A trace of another of these ornaments may be seen over the 21st capital; but I doubt if the marbles have ever been inserted in the other spandrils, and their want of ornament occasions the slight meagreness in the effect of the lower story, which is almost the only fault of the building.

This decoration by discs, or shield-like ornaments, is a marked characteristic of Venetian architecture in its earlier ages, and is carried into later times by the Byzantine Renaissance, already distinguished from the more corrupt forms of Renaissance, in Appendix 6. Of the disc decoration, so borrowed, we have already an example in Plate I. In Plate VII. we have an earlier condition of it, one of the discs being there sculptured, the others surrounded by sculptured bands: here we have, on the Ducal Palace, the most characteristic of all, because likeliest to the shield, which was probably the origin of the same ornament among the Arabs, and assuredly among the Greeks. In Mr. Donaldson's restoration of the gate of the treasury of Atreus, this ornament is conjecturally employed, and it occurs constantly on the Arabian buildings of Cairo.

21. ANCIENT REPRESENTATIONS OF WATER.

I have long been desirous of devoting some time to an enquiry into the effect of natural scenery upon the pagan, and especially the Greek, mind, and knowing that my friend, Mr. C. Newton, had devoted much thought to the elucidation of the figurative and symbolic language of ancient art, I asked him to draw up for me a few notes of the facts which he considered most interesting, as illustrative of its methods of representing nature. I suggested to him, for an initiative subject, the representation of water; because this is one of the natural objects whose portraiture may most easily be made a test of treatment, for it is one of universal interest, and of more

closely similar aspect in all parts of the world than any other. Waves, currents, and eddies are much liker each other, everywhere, than either land or vegetation. Rivers and lakes, indeed, differ widely from the sea, and the clear Pacific from the angry Northern ocean ; but the Nile is liker the Danube than a knot of Nubian palms is to a glade of the Black Forest ; and the Mediterranean is liker the Atlantic than the Campo Felice is like Solway moss.

Mr. Newton has accordingly most kindly furnished me with the following data. One or two of the types which he describes have been already noticed in the main text ; but it is well that the reader should again contemplate them in the position which they here occupy in a general system. I recommend his special attention to Mr. Newton's definitions of the terms "figurative" and "symbolic," as applied to art, in the beginning of the paper.

IN ancient art, that is to say, in the art of the Egyptian, Assyrian, Greek, and Roman races, water is, for the most part, represented conventionally rather than naturally.

By natural representation is here meant as just and perfect an imitation of nature as the technical means of art will allow : on the other hand, representation is said to be conventional, either when a confessedly inadequate imitation is accepted in default of a better, or when imitation is not attempted at all, and it is agreed that other modes of representation, those by figures or by symbols, shall be its substitute and equivalent.

In figurative representation there is always *impersonation* ; the sensible form, borrowed by the artist from organic life, is conceived to be actuated by a will, and invested with such mental attributes as constitute personality.

The sensible *symbol*, whether borrowed from organic or from inorganic nature, is not a personification at all, but the conventional sign or equivalent of some object or notion, to which it may perhaps bear no visible resemblance, but with which the intellect or the imagination has in some way associated it.

For instance, a city may be figuratively represented as a

woman crowned with towers ; here the artist has selected for the expression of his idea a human form animated with a will and motives of action analogous to those of humanity generally. Or, again, as in Greek art, a bull may be a figurative representation of a river, and, in the conception of the artist, this animal form may contain, and be ennobled by, a human mind

This is still impersonation ; the form only in which personality is embodied is changed.

Again, a dolphin may be used as a symbol of the sea ; a man ploughing with two oxen is a well-known symbol of a Roman colony. In neither of these instances is there impersonation. The dolphin is not invested, like the figure of Neptune, with any of the attributes of the human mind ; it has animal instincts, but no will ; it represents to us its native element, only as a part may be taken for a whole.

Again, the man ploughing does not, like the turreted female figure, *personify*, but rather *typifies* the town, standing as the visible representation of a real event, its first foundation. To our mental perceptions, as to our bodily senses, this figure seems no more than man ; there is no blending of his personal nature with the impersonal nature of the colony, no transfer of attributes from the one to the other.

Though the conventionally imitative, the figurative, and the symbolic, are three distinct kinds of representation, they are constantly combined in one composition, as we shall see in the following examples, cited from the art of successive races in chronological order.

In Egyptian art the general representation of water is the conventionally imitative. In the British Museum are two frescoes from tombs at Thebes, Nos. 177 and 170 : the subject of the first of these is an oblong pond, ground-plan and elevation being strangely confused in the design. In this pond water is represented by parallel zigzag lines, in which fish are swimming about. On the surface are birds and lotos flowers ; the herbage at the edge of the pond is represented by a border of symmetrical fan-shaped flowers ; the field beyond by rows of trees, arranged round the sides of the pond at right angles to each other, and in defiance of all laws of perspective.

In the fresco, No. 170, we have the representation of a river with papyrus on its bank. Here the water is rendered by zigzag lines arranged vertically and in parallel lines, so as to resemble herring-bone masonry, thus.

There are fish in this fresco as in the preceding, and in both each fish is drawn very distinctly, not as it would appear to the eye viewed through water. The mode of representing this element in Egyptian



FIG. LXXI.

painting is further abbreviated in their hieroglyphic writing, where the sign of water is a zigzag line; this line is, so to speak, a picture of water written in short hand. In the Egyptian Pantheon there was but one aquatic deity, the god of the Nile; his type is, therefore, the only figurative representation of water in Egyptian art. (Birch, "Gallery of British Museum Antiquities," Pl. 13.) In Assyrian sculpture we have very curious conventionally imitative representations of water. On several of the friezes from Nimroud and Khorsabad, men are seen crossing a river in boats, or in skins, accompanied by horses swimming (see Layard, ii. p. 381). In these scenes water is represented by masses of wavy lines somewhat resembling tresses of hair, and terminating in curls or volutes; these wavy lines express the general character of a deep and rapid current, like that of the Tigris. Fish are but sparingly introduced, the idea of surface being sufficiently expressed by the floating figures and boats. In the representation of these there is the same want of perspective as in the Egyptian fresco which we have just cited.

In the Assyrian Pantheon one aquatic deity has been discovered, the god Dagon, whose human form terminates in a fish's tail. Of the character and attributes of this deity we know but little.

The more abbreviated mode of representing water, the zigzag line, occurs on the large silver coins with the type of a city or a war galley (see Layard, ii. p. 386). These coins were probably struck in Assyria, not long after the conquest of it by the Persians.

In Greek art the modes of representing water are far more

varied. Two conventional imitations, the wave moulding and the Mæander, are well known. Both are probably of the most remote antiquity; both have been largely employed as an architectural ornament, and subordinately as a decoration of vases, costume, furniture and implements. In the wave moulding we have a conventional representation of the small crisp waves which break upon the shore of the Mediterranean, the sea of the Greeks.

Their regular succession, and equality of force and volume, are generalised in this moulding, while the minuter varieties which distinguish one wave from another are merged in the general type. The character of ocean waves is to be "for ever changing, yet the same for ever;" it is this eternity of recurrence which the early artist has expressed in this hieroglyphic.

With this profile representation of water may be compared the sculptured waves out of which the head and arms of Hyperion are rising in the pediment of the Parthenon (Elgin Room, No. (65) 91, Museum Marbles, vi. pl. 1). Phidias has represented these waves like a mass of overlapping tiles, thus generalising their rippling movement. In the Mæander pattern the graceful curves of nature are represented by angles, as in the Egyptian hieroglyphic of water: so again the earliest representation of the labyrinth on the coins of the Cnossus is rectangular; on later coins we find the curvilinear form introduced.

In the language of Greek mythography, the wave pattern and the Mæander are sometimes used singly for the idea of water, but more frequently combined with figurative representation. The number of aquatic deities in the Greek Pantheon led to the invention of a great variety of beautiful types. Some of these are very well known. Everybody is familiar with the general form of Poseidon (Neptune), the Nereids, the Nymphs and River Gods; but the modes in which these types were combined with conventional imitation and with accessory symbols deserve careful study, if we would appreciate the surpassing richness and beauty of the language of art formed out of these elements.

This class of representations may be divided into two principal groups, those relating to the sea, and those relating to fresh water.

The power of the ocean and the great features of marine scenery are embodied in such types as Poseidon, Nereus and the Nereids, that is to say, in human forms moving through the liquid element in chariots, or on the back of dolphins, or who combine the human form with that of the fish-like Tritons. The sea-monsters who draw these chariots are called Hippocamps, being composed of the tail of a fish and the fore-part of a horse, the legs terminating in web-feet : this union seems to express speed and power under perfect control, such as would characterise the movements of sea deities. A few examples have been here selected to show how these types were combined with symbols and conventional imitation.

In the British Museum is a vase, No. 1257, engraved (Lenormant et De Witte, *Mon. Céram.*, i. pl. 27), of which the subject is, Europa crossing the sea on the back of the bull. In this design the sea is represented by a variety of expedients. First, the swimming action of the bull suggests the idea of the liquid medium through which he moves. Behind him stands Nereus, his staff held perpendicularly in his hand ; the top of his staff comes nearly to the level of the bull's back, and is probably meant as the measure of the whole depth of the sea. Towards the surface line thus indicated a dolphin is rising ; in the middle depth is another dolphin ; below a shrimp and a cuttle-fish, and the bottom is indicated by a jagged line of rocks, on which are two echini.

On a mosaic found at Oudnah in Algeria (*Revue Archéol.*, iii. pl. 50), we have a representation of the sea, remarkable for the fulness of details with which it is made out.

This, though of the Roman period, is so thoroughly Greek in feeling, that it may be cited as an example of the class of mythography now under consideration. The mosaic lines the floor and sides of a bath, and, as was commonly the case in the baths of the ancients, serves as a figurative representation of the water it contained.

On the sides are hippocamps, figures riding on dolphins,

and islands on which fishermen stand ; on the floor are fish, crabs, and shrimps.

These, as in the vase with Europa, indicate the bottom of the sea : the same symbols of the submarine world appear on many other ancient designs. Thus in vase pictures, when Poseidon upheaves the island of Cos to overwhelm the Giant Polydotes, the island is represented as an immense mass of rock ; the parts which have been under water are indicated by a dolphin, a shrimp, and a sepia, the parts above the water by a goat and a serpent (Lenormant et De Witte, i., tav. 5).

Sometimes these symbols occur singly in Greek art, as the types, for instance, of coins. In such cases they cannot be interpreted without being viewed in relation to the whole context of mythography to which they belong. If we find, for example, on one coin of Tarentum a shell, on another a dolphin, on a third a figure of Tarus, the mythic founder of the town, riding on a dolphin in the midst of the waves, and this latter group expresses the idea of the town itself and its position on the coast, then we know the two former types to be but portions of the greater design, having been detached from it, as we may detach words from sentences.

The study of the fuller and clearer examples, such as we have cited above, enables us to explain many more compendious forms of expression. We have, for instance, on coins several representations of ancient harbors.

Of these, the earliest occurs on the coins of Zancle, the modern Messina in Sicily. The ancients likened the form of this harbor to a sickle, and on the coins of the town we find a curved object, within the area of which is a dolphin. On this curve are four square elevations placed at equal distances. It has been conjectured that these projections are either towers or the large stones to which galleys were moored still to be seen in ancient harbors (see Burgon, Numismatic Chronicle, iii. p. 40). With this archaic representation of a harbor may be compared some examples of the Roman period. On a coin of Sept. Severus struck at Corinth (Millingen, Sylloge of Uned. Coins, 1837, p. 57, Pl. II. No. 30) we have a female figure standing on a rock between two recumbent male figures

holding rudders. From an arch at the foot of the rock a stream is flowing : this is a representation of the rock of the Acropolis of Corinth ; the female figure is a statue of Aphrodite, whose temple surmounted the rock. The stream is the fountain Pirene. The two recumbent figures are impersonations of the two harbors, Lechreum and Cenchreia, between which Corinth was situated. Philostratus (Icon. ii., c. 16) describes a similar picture of the Isthmus between the two harbors, one of which was in the form of a youth, the other of a nymph.

On another coin of Corinth we have one of the harbors in a semicircular form, the whole arc being marked with small equal divisions, to denote the archways under which the ancient galleys were drawn, *subductæ* ; at the either horn or extremity of the harbor is a temple ; in the centre of the mouth, a statue of Neptune. (Millingen, *Médailles Inéd.*, Pl. II., No. 19. Compare also Millingen, *Ancient Coins of Cities and Kings*, 1831, pp. 50—61, Pl. IV., No. 15 ; Mionnet, *Suppl.* vii. p. 79, No. 246 ; and the harbor of Ostium, on the large brass coins of Nero, in which there is a representation of the Roman fleet and a reclining figure of Neptune.)

In vase pictures we have occasionally an attempt to represent water naturally. On a vase in the British Museum (No. 785), of which the subject is Ulysses and the Sirens, the Sea is rendered by wavy lines drawn in black on a red ground, and something like the effect of light playing on the surface of the water is given. On each side of the ship are shapeless masses of rock on which the Sirens stand.

One of the most beautiful of the figurative representations of the sea is the well-known type of Scylla. She has a beautiful body, terminating in two barking dogs and two serpent tails. Sometimes drowning men, the *rari nantes in gurgite vasto*, appear caught up in the coils of these tails. Below are dolphins. Scylla generally brandishes a rudder to show the manner in which she twists the course of ships. For varieties of her type see *Monum. dell' Inst. Archeol. Rom.*, iii. Tavv. 52—3.

The representations of fresh water may be arranged under the following heads—rivers, lakes, fountains.

There are several figurative modes of representing rivers very frequently employed in ancient mythography.

In the type which occurs earliest we have the human form combined with that of the bull in several ways. On an archaic coin of Metapontum in Lucania, (see frontispiece to Millingen, *Ancient Coins of Greek Cities and Kings*,) the river Achelous is represented with the figure of a man with a shaggy beard and bull's horns and ears. On a vase of the best period of Greek art (*Brit. Mus. No. 789*; *Birch, Trans. Roy. Soc. of Lit., New Series, Lond. 1843, i. p. 100*) the same river is represented with a satyr's head and long bull's horns on the forehead; his form, human to the waist, terminates in a fish's tail; his hair falls down his back; his beard is long and shaggy. In this type we see a combination of the three forms separately enumerated by Sophocles, in the commencement of the *Trachiniæ*.

Ἄχελῶν λέγω,
 ος μ' ἐν τρισὶν μορφαῖσιν ἐξήτει πατρός,
 φοιτῶν ἐναργῆς αὔρος ἄλλοτ' αἰόλος,
 δράκων ἐλικτός, ἄλλοτ' ἄνδρειψ κύτεί
 βουπρωρος, ἐκ δὲ δασκίου γενειάδος
 κρουνοὶ διεβραίνοντο κρηναίου ποτοῦ.

In a third variety of this type the human-headed body is united at the waist with the shoulders of a bull's body, in which it terminates. This occurs on an early vase. (*Brit. Mus., No. 452.*) On the coins of *Æniadæ* in *Acarinia*, and on those of *Ambracia*, all of the period after Alexander the Great, the Achelous has a bull's body, and head with a human face. In this variety of the type the human element is almost absorbed, as in the first variety cited above, the coin of *Metapontum*, the bull portion of the type is only indicated by the addition of the horns and ears to the human head. On the analogy between these varieties in the type of the Achelous and those under which the metamorphoses of the marine goddess *Thetis* are represented, see *Gerhard, Auserl Vasenb. ii. pp. 106—113.* It is probable that, in the type of *Thetis*, of *Proteus*, and also of the Achelous, the singular combinations and

transformations are intended to express the changeful nature of the element water.

Numerous other examples may be cited, where rivers are represented by this combination of the bull and human form, which may be called, for convenience, the Androtauric type. On the coins of Sicily, of the archaic and also of the finest period of art, rivers are most usually represented by a youthful male figure, with small budding horns; the hair has the lank and matted form which characterises aquatic deities in Greek mythology. The name of the river is often inscribed round the head. When the whole figure occurs on the coin, it is always represented standing, never reclining.

The type of the bull on the coins of Sybaris and Thurium, in Magna Græcia, has been considered, with great probability, a representation of this kind. On the coins of Sybaris, which are of a very early period, the head of the bull is turned round; on those of Thurium, he stoops his head, butting: the first of these actions has been thought to symbolise the winding course of the river, the second, its headlong current. On the coins of Thurium, the idea of water is further suggested by the adjunct of dolphins and other fish in the exergue of the coin. The ground on which the bull stands is indicated by herbage or pebbles. This probably represents the river bank. Two bulls' head occur on the coins of Sardis, and it has been ingeniously conjectured by Mr. Burgon that the two rivers of the place are expressed under this type.

The representation of river-gods as human figures in a reclining position, though probably not so much employed in earlier Greek art as the Androtauric type, is very much more familiar to us, from its subsequent adoption in Roman mythology. The earliest example we have of a reclining river-god is in the figure in the Elgin Room commonly called the Ilissus, but more probably the Cephissus. This occupied one angle in the western pediment of the Parthenon; the other Athenian river, the Ilissus, and the fountain Callirrhoe being represented by a male and female figure in the opposite angle; this group, now destroyed, is visible in the drawing made by Carrey in 1678.

It is probable that the necessities of pedimental composition first led the artist to place the river-god in a reclining position. The head of the Ilissus being broken off, we are not sure whether he had bull's horns, like the Sicilian figures already described. His form is youthful, in the folds of the drapery behind him there is a flow like that of waves, but the idea of water is not suggested by any other symbol. When we compare this figure with that of the Nile (Visconti, *Mus. Pio Clem.*, i., Pl. 38), and the figure of the Tiber in the Louvre, both of which are of the Roman period, we see how in these later types the artist multiplied symbols and accessories, ingrafting them on the original simple type of the river-god, as it was conceived by Phidias in the figure of the Ilissus. The Nile is represented as a colossal bearded figure reclining. At his side is a cornucopia, full of the vegetable produce of the Egyptian soil. Round his body are sixteen naked boys, who represent the sixteen cubits, the height to which the river rose in a favorable year. The statue is placed on a basement divided into three compartments, one above another. In the uppermost of these, waves are flowing over in one great sheet from the side of the river-god. In the other two compartments are the animals and plants of the river; the bas-reliefs on this basement are, in fact, a kind of abbreviated symbolic panorama of the Nile.

The Tiber is represented in a very similar manner. On the base are, in two compartments, scenes taken from the early Roman myths; flocks, herds, and other objects on the banks of the river. (Visconti, *Mus. P. Cl. i.*, Pl. 39; Millin, *Galerie Mythol.*, i. p. 77, Pl. 74, Nos. 304, 308.)

In the types of the Greek coins of Camarina, we find two interesting representations of Lakes. On the obverse of one of these we have, within a circle of the wave pattern, a male head, full face, with dishevelled hair, and with a dolphin on either side; on the reverse a female figure sailing on a swan, below which a wave moulding, and above, a dolphin.

On another coin the swan type of the reverse is associated with the youthful head of a river-god, inscribed "Hipparis" on the obverse. On some smaller coins we have the swan

flying over the rippling waves, which are represented by the wave moulding. When we examine the chart of Sicily, made by the Admiralty survey, we find marked down at Camarina, a lake through which the river Hipparis flows.

We can hardly doubt that the inhabitants of Camarina represented both their river and their lakes on their coins. The swan flying over the waves would represent a lake; the figure associated with it being no doubt the Aphrodite worshipped at that place: the head, in a circle of wave pattern, may express that part of the river which flows through the lake.

Fountains are usually represented by a stream of water issuing from a lion's head in the rock: see a vase (Gerhard, *Auserl. Vasenb.*, taf. cxxxiv.), where Hercules stands, receiving a shower-bath from a hot spring at Thermæ in Sicily. On the coins of Syracuse the fountain Arethusa is represented by a female head seen to the front; the flowing lines of her dishevelled hair suggest, though they do not directly imitate, the bubbling action of the fresh-water spring; the sea in which it rises is symbolized by the dolphins round the head. This type presents a striking analogy with that of the Camarina head in the circle of wave pattern described above.

These are the principal modes of representing water in Greek mythography. In the art of the Roman period, the same kind of figurative and symbolic language is employed, but there is a constant tendency to multiply accessories and details, as we have shown in the later representations of harbors and river-gods cited above. In these crowded compositions the eye is fatigued and distracted by the quantity it has to examine; the language of art becomes more copious but less terse and emphatic, and addresses itself to minds far less intelligent than the refined critics who were the contemporaries of Phidias.

Rivers in Roman art are usually represented by reclining male figures, generally bearded, holding reeds or other plants in their hands, and leaning on urns from which water is flowing. On the coins of many Syrian cities, struck in imperial times, the city is represented by a turreted female figure seated on rocks, and resting her feet on the shoulder of a youthful male figure, who looks up in her face, stretching out his arms,

and who is sunk in the ground as high as the waist. See Müller (Denkmäler d. A. Kunst, i., taf. 49, No 220) for a group of this kind in the Vatican, and several similar designs on coins.

On the column of Trajan there occur many rude representations of the Danube, and other rivers crossed by the Romans in their military expeditions. The water is imitated by sculptured wavy lines, in which boats are placed. In one scene (Bartoli, Colonna Trajana, Tav. 4) this rude conventional imitation is combined with a figure. In a recess in the river bank is a reclining river-god, terminating at the waist. This is either meant for a statue which was really placed on the bank of the river, and which therefore marks some particular locality, or we have here figurative representation blended with conventional imitation.

On the column of Antoninus (Bartoli, Colon. Anton., Tav. 15) a storm of rain is represented by the head of Jupiter Pluvius, who has a vast outspread beard flowing in long tresses. In the Townley collection, in the British Museum, is a Roman helmet found at Ribchester in Lancashire, with a mask or vizor attached. The helmet is richly embossed with figures in a battle scene; round the brow is a row of turrets; the hair on the forehead is so treated as to give the idea of waves washing the base of the turrets. This head is perhaps a figurative representation of a town girt with fortifications and a moat, near which some great battle was fought. It is engraved (Vetusta Monum. of Soc. Ant. London, iv., Pl. 1-4).

In the Galeria at Florence is a group in alto relievo (Gori, Inscript. Ant. Flor. 1727, p. 76. Tab. 14) of three female figures, one of whom is certainly Demeter Kourotrophos, or the earth; another, Thetis, or the sea; the centre of the three seems to represent Aphrodite associated, as on the coins of Camarina, with the element of fresh water.

This figure is seated on a swan, and holds over her head an arched veil. Her hair is bound with reeds; above her veil grows a tall water plant, and below the swan other water plants, and a stork seated on a *hydria*, or pitcher, from which water is flowing. The swan, the stork, the water plants, and

the *hydria* must all be regarded as symbols of fresh water, the latter emblem being introduced to show that the element is fit for the use of man.

Fountains in Roman art are generally personified as figures of nymphs reclining with urns, or standing holding before them a large shell.

One of the latest representations of water in ancient art is the mosaic of Palestrina (Barthélemy, in Bartoli, *Peint. Antiques*) which may be described as a kind of rude panorama of some district of Upper Egypt, a bird's-eye view, half man, half picture, in which the details are neither adjusted to a scale, nor drawn according to perspective, but crowded together, as they would be in an ancient bas-relief.

22. ARABIAN ORNAMENTATION.

I do not mean what I have here said of the Inventive power of the Arab to be understood as in the least applying to the detestable ornamentation of the Alhambra.* The Alhambra is no more characteristic of Arab work, than Milan Cathedral is of Gothic: it is a late building, a work of the Spanish dynasty in its last decline, and its ornamentation is fit for nothing but to be transferred to patterns of carpets or bindings of books, together with their marbling, and mottling, and other mechanical recommendations. The Alhambra ornament has of late been largely used in shop-fronts, to the no small detriment of Regent Street and Oxford Street.

23. VARIETIES OF CHAMFER.

Let BAC , Fig. LXXII., be the original angle of the wall. Inscribe within it a circle, $pQNp$, of the size of the bead required, touching AB , AC , in p , p ; join p , p , and draw BC parallel to it, touching the circle.

Then the lines BC , pp are the limits of the possible chamfers constructed with curves struck either from centre A , as

* I have not seen the building itself, but Mr. Owen Jones's work may, I suppose, be considered as sufficiently representing it for all purposes of criticism.

the line Qq , Nd , ru , gc , &c., or from any other point chosen as a centre in the direction QA produced: and also of all chamfers in straight lines, ab , ef . There are, of course, an infinite number of chamfers to be struck between BC and pp , from every point in QA produced to infinity; thus we have infinity multiplied into infinity to express the number of possible chamfers of this species, which are peculiarly Italian chamfers; together with another singly infinite group of the straight chamfers, ab , ef , &c., of which the one formed by

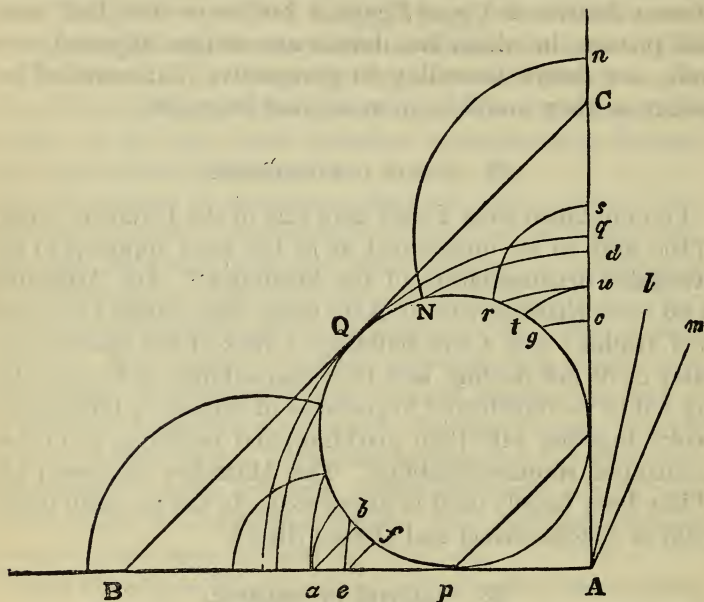

FIG. LXXII.

the line ab , passing through the centre of the circle, is the universal early Gothic chamfer of Venice.

Again. Either on the line AC , or on any other lines Al or Am , radiating from A , any number of centres may be taken, from which, with any radii not greater than the distance between such points and Q , an infinite number of curves may be struck, such as tu , rs , Nn (all which are here struck from centres on the line AC). These lines represent the great

class of the northern chamfers, of which the number is infinity raised to its fourth power, but of which the curve $N n$ (for northern) represents the average condition; the shallower chamfers of the same group, $r s$, $t u$, &c., occurring often in Italy. The lines $r u$, $t u$, and $a b$ may be taken approximating to the most frequent conditions of the southern chamfer.

It is evident that the chords of any of these curves will give a relative group of rectilinear chamfers, occurring both in the North and South; but the rectilinear chamfers, I think, invariably fall within the line $Q C$, and are either parallel with it, or inclined to $A C$ at an angle greater than $A C Q$, and often perpendicular to it; but never inclined to it at an angle less than $A C Q$.

24. RENAISSANCE BASES.

The following extract from my note-book refers also to some features of late decoration of shafts.

“The Scuola di San Rocco is one of the most interesting examples of Renaissance work in Venice. Its fluted pillars are surrounded each by a wreath, one of vine, another of laurel, another of oak, not indeed arranged with the fantasticism of early Gothic; but, especially the laurel, reminding one strongly of the laurel sprays, powerful as well as beautiful, of Veronese and Tintoret. Their stems are curiously and richly interlaced—the last vestige of the Byzantine wreathed work—and the vine-leaves are ribbed on the surfaces, I think, nearly as finely as those of the Noah,* though more injured by time. The capitals are far the richest Renaissance in Venice, less corrupt and more masculine in plan, than any other, and truly suggestive of support, though of course showing the tendency to error in this respect; and finally, at the angles of the pure Attic bases, on the square plinth, are set couchant animals; one, an elephant four inches high, very curiously and cleverly cut, and all these details worked with a spirit, finish, fancy, and affection quite worthy of the middle ages.

* The sculpture of the Drunkenness of Noah on the Ducal Palace, of which we shall have much to say hereafter.

But they have all the marked fault of being utterly detached from the architecture. The wreaths round the columns look as if they would drop off the next moment, and the animals at the bases produce exactly the effect of mice who had got there by accident: one feels them ridiculously diminutive, and utterly useless."

The effect of diminutiveness is, I think, chiefly owing to there being no other groups of figures near them, to accustom the eye to the proportion, and to the needless choice of the largest animals, elephants, bears, and lions, to occupy a position so completely insignificant, and to be expressed on so contemptible a scale,—not in a bas-relief or pictorial piece of sculpture, but as independent figures. The whole building is a most curious illustration of the appointed fate of the Renaissance architects,—to caricature whatever they imitated, and misapply whatever they learned.

25. ROMANIST DECORATION OF BASES.

I have spoken above (Appendix 12) of the way in which the Roman Catholic priests everywhere suffer their churches to be desecrated. But the worst instances I ever saw of sacrilege and brutality, daily permitted in the face of all men, were the uses to which the noble base of St. Mark's was put, when I was last in Venice. Portions of nearly all cathedrals may be found abandoned to neglect; but this base of St. Mark's is in no obscure position. Full fronting the western sun—crossing the whole breadth of St. Mark's Place—the termination of the most noble square in the world—the centre of the most noble city—its purple marbles were, in the winter of 1849, the customary *gambling tables* of the idle children of Venice; and the parts which flank the Great Entrance, that very entrance where "Barbarossa flung his mantle off," were the counters of a common bazaar for children's toys, carts, dolls, and small pewter spoons and dishes, German caricatures and books of the Opera, mixed with those of the offices of religion; the caricatures being fastened with twine round the porphyry shafts of the church. One Sunday, the 24th of February,

1850, the book-stall being somewhat more richly laid out than usual, I noted down the titles of a few of the books in the order in which they lay, and I give them below. The irony conveyed by the juxtaposition of the three in Italics appears too shrewd to be accidental ; but the fact was actually so.

Along the edge of the white plinth were a row of two kinds of books,

Officium Beatæ Virg. M. ; and Officium Hebdomadæ sanctæ, juxta Formam Missalis et Breviarii Romani sub Urbano VIII. correcti.

Behind these lay, side by side, the following :

Don Desiderio. *Dramma Giocoso per Musica.*

Breve Esposizione della Carattere di vera Religione.

On the top of this latter, keeping its leaves open,

La Figlia del Reggimento. *Melodramma comica.*

Carteggio di Madama la Marchesa di Pompadour, ossia raccolta di Lettere scritte della Medesima.

Istruzioni di morale Condotta per le Figlie.

Francesca di Rimini. Dramma per Musica.

Then, a little farther on, after a mass of plays :—

Orazioni a Gesu Nazareno e a Maria addolorata.

Semiramide ; *Melodramma tragico da rappresentarsi nel Gran Teatro il Fenice.*

Modo di orare per l'Acquisto del S. Giubileo, conceduto a tutto il Mondo Cattolico da S. S. Gregorio XVI.

Le due illustre Rivali, *Melodramma in Tre Atti, da rappresentarsi nel nuovo Gran Teatro il Fenice.*

Il Cristiano secondo il Cuore di Gesu, per la Pratica delle sue Virtu.

Traduzione del' Idioma Italiana.

La chiave Chinese ; *Commedia del Sig. Abate Pietro Chiari.*

La Pelarina ; *Intermezzo de Tre Parti per Musica.*

Il Cavaliere e la Dama ; *Commedia in Tre Atti in Prosa.*

I leave these facts without comment. But this being the last piece of Appendix I have to add to the present volume, I

would desire to close its pages with a question to my readers—a statistical question, which, I doubt not, is being accurately determined for us all elsewhere, and which, therefore, it seems to me, our time would not be wasted in determining for ourselves.

There has now been peace between England and the continental powers about thirty-five years, and during that period the English have visited the continent at the rate of many thousands a year, staying there, I suppose, on the average, each two or three months; nor these an inferior kind of English, but the kind which ought to be the best—the noblest born, the best taught, the richest in time and money, having more leisure, knowledge, and power than any other portion of the nation. These, we might suppose, beholding, as they travelled, the condition of the states in which the Papal religion is professed, and being, at the same time, the most enlightened section of a great Protestant nation, would have been animated with some desire to dissipate the Romanist errors, and to communicate to others the better knowledge which they possessed themselves. I doubt not but that He who gave peace upon the earth, and gave it by the hand of England, expected this much of her, and has watched every one of the millions of her travellers as they crossed the sea, and kept count for him of his travelling expenses, and of their distribution, in a manner of which neither the traveller nor his courier were at all informed. I doubt not, I say, but that such accounts have been literally kept for all of us, and that a day will come when they will be made clearly legible to us, and when we shall see added together, on one side of the account book, a great sum, the certain portion, whatever it may be, of this thirty-five years' spendings of the rich English, accounted for in this manner:—

To wooden spoons, nut-crackers, and jewellery, bought at Geneva, and elsewhere among the Alps, so much; to shell cameos and bits of mosaic bought at Rome, so much; to coral horns and lava brooches bought at Naples, so much; to glass beads at Venice, and gold filigree at Genoa, so much; to pictures, and statues, and ornaments, everywhere, so much; to

avant-couriers and extra post-horses, for show and magnificence, so much ; to great entertainments and good places for seeing sights, so much ; to ball-dresses and general vanities, so much. This, I say, will be the sum on one side of the book ; and on the other will be written,

To the struggling Protestant Churches of France, Switzerland, and Piedmont, so much.

Had we not better do this piece of statistics for ourselves, in time ?

THE
STONES OF VENICE

VOLUME THE SECOND
THE SEA STORIES

ADVERTISEMENT.

It was originally intended that this Work should consist of two volumes only ; the subject has extended to three. The second volume, however, will conclude the account of the ancient architecture of Venice. The third will embrace the Early, the Roman, and the Grotesque Renaissance ; and an Index, which, as it gives, in alphabetical order, a brief account of all the buildings in Venice, or references to the places where they are mentioned in the text, will be found a convenient guide for the traveller. In order to make it more serviceable, I have introduced some notices of the pictures which I think most interesting in the various churches, and in the Scuola di San Rocco.

CONTENTS.

FIRST, OR BYZANTINE, PERIOD.

	PAGE
CHAPTER I.	
The Throne,	7
CHAPTER II.	
Torcello,	16
CHAPTER III.	
Murano,	31
CHAPTER IV.	
St. Mark's,	60
CHAPTER V.	
Byzantine Palaces,	120

SECOND, OR GOTHIC, PERIOD.

CHAPTER VI.	
The Nature of Gothic,	152

	PAGE
CHAPTER VII.	
Gothic Palaces,	230

CHAPTER VIII.	
The Ducal Palace,	279

APPENDIX.

1. The Gondolier's Cry,	373
2. Our Lady of Salvation,	376
3. Tides of Venice, and Measures at Torcello,	377
4. Date of the Duomo of Torcello,	378
5. Modern Pulpits,	379
6. Apse of Murano,	380
7. Early Venetian Dress,	381
8. Inscriptions at Murano,	382
9. Shafts of St. Mark,	382
10. Proper Sense of the Word Idolatry,	387
11. Situations of Byzantine Palaces,	390
12. Modern Painting on Glass,	392

LIST OF ILLUSTRATIONS.

STONES OF VENICE, VOLUME TWO.

PLATE	FACING PAGE
1. Plans of Torcello and Murano,	20
2. The Acanthus of Torcello,	21
3. Inlaid Bands of Murano,	45
4. Sculptures of Murano,	47
5. Archivolt in the Duomo of Murano,	50
6. The Vine. Free, and in Service,	98
7. Byzantine Capitals. Convex Group,	130
8. Byzantine Capitals. Concave Group,	134
9. Lily Capital of St. Marks,	138
10. Four Venetian Flower Orders (to follow Plate 9).	
11. Byzantine Sculpture,	140
12. Linear and Surface Gothic,	224
13. Balconies,	246
14. The Orders of Venetian Arches,	248
15. Windows of the Second Order. Casa Falier,	253
16. Windows of the Fourth Order,	256
17. Windows of the Early Gothic Palaces,	258
18. Windows of the Fifth Order,	264
19. Leafage of the Vine Angle,	308
20. Leafage of the Venetian Capitals,	366

LIST OF ILLUSTRATIONS.

FIGURE	PAGE
1. Triple Chain,	21
2. Bands of Murano,	49
Latin Inscription,	52
3. Archivolts of St. Marks and Murano,	54
4. The Fondaco de' Turchi,	123
Diagram of Pillars. Casa Loredan,	125
5. Arches of St. Marks, Lines of,	128
6. Leaf Group,	129
7. Six Petal Star,	130
8. Flat Lintel Windows,	211
9. Pointed Arch (outline),	212
10. Gothic Arches,	213
11. Architecture of Lintel, Round Arch and Gable,	214
12. Architecture of Greek, Western Romanesque, and True Gothic,	215
13. Gothic and Romanesque Gables,	216
14. Gothic and Romanesque Gables,	217
15. Weak and Strong Arch,	218
16. Foliation,	219
17. Foliation,	219
18. Designs of Moulding,	221
19. Foliated Architecture,	222
20. Veronese Niche Ornament,	227
21. Frari Traceries,	233
22. Quatrefoil,	234
23. Roof Parapets,	240
24. Parapets,	243
25. Traceried Parapet,	244
26. Door and Window in the Corte del Remer,	250
27. Stone Arch,	251
28. Brick Arches,	251

LIST OF ILLUSTRATIONS.

FIGURE	PAGE
29. Archivolt Profiles,	252
30. Keystone,	254
31. Windows of the Third Order,	256
32. Windows from the Salizada San Liò,	256
33. Gothic Trefoils,	258
34. Gothic Trefoil,	258
35. Window. Brick Level Head,	268
36. (Not in),	280
37. (Not in),	281
38. Façade,	283

THE STONES OF VENICE.

FIRST, OR BYZANTINE, PERIOD.

CHAPTER I.

THE THRONE.

§ 1. IN the olden days of travelling, now to return no more, in which distance could not be vanquished without toil, but in which that toil was rewarded, partly by the power of deliberate survey of the countries through which the journey lay, and partly by the happiness of the evening hours, when, from the top of the last hill he had surmounted, the traveller beheld the quiet village where he was to rest, scattered among the meadows beside its valley stream ; or, from the long-hoped-for turn in the dusty perspective of the causeway, saw, for the first time, the towers of some famed city, faint in the rays of sunset—hours of peaceful and thoughtful pleasure, for which the rush of the arrival in the railway station is perhaps not always, or to all men, an equivalent,—in those days, I say, when there was something more to be anticipated and remembered in the first aspect of each successive halting-place, than a new arrangement of glass roofing and iron girder, there were few moments of which the recollection was more fondly cherished by the traveller than that which, as I endeavored to describe in the close of the last chapter, brought him within sight of Venice, as his gondola shot into the open lagoon from the canal of Mestre. Not but that the aspect of the city itself was generally the source of some slight disappointment, for, seen in this direction, its buildings are far less characteristic than

those of the other great towns of Italy ; but this inferiority was partly disguised by distance, and more than atoned for by the strange rising of its walls and towers out of the midst, as it seemed, of the deep sea, for it was impossible that the mind or the eye could at once comprehend the shallowness of the vast sheet of water which stretched away in leagues of rippling lustre to the north and south, or trace the narrow line of islets bounding it to the east. The salt breeze, the white moaning sea-birds, the masses of black weed separating and disappearing gradually, in knots of heaving shoal, under the advance of the steady tide, all proclaimed it to be indeed the ocean on whose bosom the great city rested so calmly ; not such blue, soft, lake-like ocean as bathes the Neapolitan promontories, or sleeps beneath the marble rocks of Genoa, but a sea with the bleak power of our own northern waves, yet subdued into a strange spacious rest, and changed from its angry pallor into a field of burnished gold, as the sun declined behind the bell-tower of the lonely island church, fitly named " St. George of the Seaweed." As the boat drew nearer to the city, the coast which the traveller had just left sank behind him into one long, low, sad-colored line, tufted irregularly with brushwood and willows : but, at what seemed its northern extremity, the hills of Arqua rose in a dark cluster of purple pyramids, balanced on the bright mirage of the lagoon ; two or three smooth surges of inferior hill extended themselves about their roots, and beyond these, beginning with the craggy peaks above Vicenza, the chain of the Alps girded the whole horizon to the north—a wall of jagged blue, here and there showing through its clefts a wilderness of misty precipices, fading far back into the recesses of Cadore, and itself rising and breaking away eastward, where the sun struck opposite upon its snow, into mighty fragments of peaked light, standing up behind the barred clouds of evening, one after another, countless, the crown of the Adrian Sea, until the eye turned back from pursuing them, to rest upon the nearer burning of the campaniles of Murano, and on the great city, where it magnified itself along the waves, as the quick silent pacing of the gondola drew nearer and nearer. And at last, when its walls were

reached, and the outmost of its untrodden streets was entered, not through towered gate or guarded rampart, but as a deep inlet between two rocks of coral in the Indian sea ; when first upon the traveller's sight opened the long ranges of columned palaces,—each with its black boat moored at the portal,—each with its image cast down, beneath its feet, upon that green pavement which every breeze broke into new fantasies of rich tessellation ; when first, at the extremity of the bright vista, the shadowy Rialto threw its colossal curve slowly forth from behind the palace of the Camerlenghi ; that strange curve, so delicate, so adamantine, strong as a mountain cavern, graceful as a bow just bent ; when first, before its moonlike circumference was all risen, the gondolier's cry, " Ah ! Stall," * struck sharp upon the ear, and the prow turned aside under the mighty cornices that half met over the narrow canal, where the splash of the water followed close and loud, ringing along the marble by the boat's side ; and when at last that boat darted forth upon the breadth of silver sea, across which the front of the Ducal palace, flushed with its sanguine veins, looks to the snowy dome of Our Lady of Salvation, † it was no marvel that the mind should be so deeply entranced by the visionary charm of a scene so beautiful and so strange, as to forget the darker truths of its history and its being. Well might it seem that such a city had owed her existence rather to the rod of the enchanter, than the fear of the fugitive ; that the waters which encircled her had been chosen for the mirror of her state, rather than the shelter of her nakedness ; and that all which in nature was wild or merciless,—Time and Decay, as well as the waves and tempests,—had been won to adorn her instead of to destroy, and might still spare, for ages to come, that beauty which seemed to have fixed for its throne the sands of the hour-glass as well as of the sea.

§ II. And although the last few eventful years, fraught with change to the face of the whole earth, have been more fatal in their influence on Venice than the five hundred that preceded

* Appendix 1, "The Gondolier's Cry."

† Appendix 2, "Our Lady of Salvation."

them ; though the noble landscape of approach to her can now be seen no more, or seen only by a glance, as the engine slackens its rushing on the iron line ; and though many of her palaces are for ever defaced, and many in desecrated ruins, there is still so much of magic in her aspect, that the hurried traveller, who must leave her before the wonder of that first aspect has been worn away, may still be led to forget the humility of her origin, and to shut his eyes to the depth of her desolation. They, at least, are little to be envied, in whose hearts the great charities of the imagination lie dead, and for whom the fancy has no power to repress the importunity of painful impressions, or to raise what is ignoble, and disguise what is discordant, in a scene so rich in its remembrances, so surpassing in its beauty. But for this work of the imagination there must be no permission during the task which is before us. The impotent feelings of romance, so singularly characteristic of this century, may indeed gild, but never save the remains of those mightier ages to which they are attached like climbing flowers ; and they must be torn away from the magnificent fragments, if we would see them as they stood in their own strength. Those feelings, always as fruitless as they are fond, are in Venice not only incapable of protecting, but even of discerning, the objects to which they ought to have been attached. The Venice of modern fiction and drama is a thing of yesterday, a mere efflorescence of decay, a stage dream which the first ray of daylight must dissipate into dust. No prisoner, whose name is worth remembering, or whose sorrow deserved sympathy, ever crossed that "Bridge of Sighs," which is the centre of the Byronic ideal of Venice ; no great merchant of Venice ever saw that Rialto under which the traveller now passes with breathless interest : the statue which Byron makes Faliero address as of one of his great ancestors was erected to a soldier of fortune a hundred and fifty years after Faliero's death ; and the most conspicuous parts of the city have been so entirely altered in the course of the last three centuries, that if Henry Dandolo or Francis Foscari could be summoned from their tombs, and stood each on the deck of his galley at the entrance of the Grand Canal, that

renowned entrance, the painter's favorite subject, the novelist's favorite scene, where the water first narrows by the steps of the Church of La Salute,—the mighty Doges would not know in what spot of the world they stood, would literally not recognize one stone of the great city, for whose sake, and by whose ingratitude, their grey hairs had been brought down with bitterness to the grave. The remains of *their* Venice lie hidden behind the cumbrous masses which were the delight of the nation in its dotage; hidden in many a grass-grown court, and silent pathway, and lightless canal, where the slow waves have sapped their foundations for five hundred years, and must soon prevail over them for ever. It must be our task to glean and gather them forth, and restore out of them some faint image of the lost city, more gorgeous a thousand-fold than that which now exists, yet not created in the day-dream of the prince, nor by the ostentation of the noble, but built by iron hands and patient hearts, contending against the adversity of nature and the fury of man, so that its wonderfulness cannot be grasped by the indolence of imagination, but only after frank inquiry into the true nature of that wild and solitary scene, whose restless tides and trembling sands did indeed shelter the birth of the city, but long denied her dominion.

§ III. When the eye falls casually on a map of Europe, there is no feature by which it is more likely to be arrested than the strange sweeping loop formed by the junction of the Alps and Apennines, and enclosing the great basin of Lombardy. This return of the mountain chain upon itself causes a vast difference in the character of the distribution of its débris on its opposite sides. The rock fragments and sediment which the torrents on the north side of the Alps bear into the plains are distributed over a vast extent of country, and, though here and there lodged in beds of enormous thickness, soon permit the firm substrata to appear from underneath them; but all the torrents which descend from the southern side of the High Alps, and from the northern slope of the Apennines, meet concentrically in the recess or mountain bay which the two ridges enclose; every fragment which thunder breaks out of

their battlements, and every grain of dust which the summer rain washes from their pastures, is at last laid at rest in the blue sweep of the Lombardic plain; and that plain must have risen within its rocky barriers as a cup fills with wine, but for two contrary influences which continually depress, or disperse from its surface, the accumulation of the ruins of ages.

§ iv. I will not tax the reader's faith in modern science by insisting on the singular depression of the surface of Lombardy, which appears for many centuries to have taken place steadily and continually; the main fact with which we have to do is the gradual transport, by the Po and its great collateral rivers, of vast masses of the finer sediment to the sea. The character of the Lombardic plains is most strikingly expressed by the ancient walls of its cities, composed for the most part of large rounded Alpine pebbles alternating with narrow courses of brick; and was curiously illustrated in 1848, by the ramparts of these same pebbles thrown up four or five feet high round every field, to check the Austrian cavalry in the battle under the walls of Verona. The finer dust among which these pebbles are dispersed is taken up by the rivers, fed into continual strength by the Alpine snow, so that, however pure their waters may be when they issue from the lakes at the foot of the great chain, they become of the color and opacity of clay before they reach the Adriatic; the sediment which they bear is at once thrown down as they enter the sea, forming a vast belt of low land along the eastern coast of Italy. The powerful stream of the Po of course builds forward the fastest; on each side of it, north and south, there is a tract of marsh, fed by more feeble streams, and less liable to rapid change than the delta of the central river. In one of these tracts is built RAVENNA, and in the other VENICE.

§ v. What circumstances directed the peculiar arrangement of this great belt of sediment in the earliest times, it is not here the place to inquire. It is enough for us to know that from the mouths of the Adige to those of the Piave there stretches, at a variable distance of from three to five miles from the actual shore, a bank of sand, divided into long

islands by narrow channels of sea. The space between this bank and the true shore consists of the sedimentary deposits from these and other rivers, a great plain of calcareous mud, covered, in the neighborhood of Venice, by the sea at high water, to the depth in most places of a foot or a foot and a half, and nearly everywhere exposed at low tide, but divided by an intricate network of narrow and winding channels, from which the sea never retires. In some places, according to the run of the currents, the land has risen into marshy islets, consolidated, some by art, and some by time, into ground firm enough to be built upon, or fruitful enough to be cultivated: in others, on the contrary, it has not reached the sea-level; so that, at the average low water, shallow lakelets glitter among its irregularly exposed fields of seaweed. In the midst of the largest of these, increased in importance by the confluence of several large river channels towards one of the openings in the sea bank, the city of Venice itself is built, on a crowded cluster of islands; the various plots of higher ground which appear to the north and south of this central cluster, have at different periods been also thickly inhabited, and now bear, according to their size, the remains of cities, villages, or isolated convents and churches, scattered among spaces of open ground, partly waste and encumbered by ruins, partly under cultivation for the supply of the metropolis.

§ VI. The average rise and fall of the tide is about three feet (varying considerably with the seasons*); but this fall, on so flat a shore, is enough to cause continual movement in the waters, and in the main canals to produce a reflux which frequently runs like a mill stream. At high water no land is visible for many miles to the north or south of Venice, except in the form of small islands crowned with towers or gleaming with villages: there is a channel, some three miles wide, between the city and the mainland, and some mile and a half wide between it and the sandy breakwater called the Lido, which divides the lagoon from the Adriatic, but which is so low as hardly to disturb the impression of the city's having been built in the midst of the ocean, although the secret of

* Appendix 3, "Tides of Venice."

its true position is partly, yet not painfully, betrayed by the clusters of piles set to mark the deep-water channels, which undulate far away in spotty chains like the studded backs of huge sea-snakes, and by the quick glittering of the crisped and crowded waves that flicker and dance before the strong winds upon the unlifted level of the shallow sea. But the scene is widely different at low tide. A fall of eighteen or twenty inches is enough to show ground over the greater part of the lagoon; and at the complete ebb the city is seen standing in the midst of a dark plain of seaweed, of gloomy green, except only where the larger branches of the Brenta and its associated streams converge towards the port of the Lido. Through this salt and sombre plain the gondola and the fishing-boat advance by tortuous channels, seldom more than four or five feet deep, and often so choked with slime that the heavier keels furrow the bottom till their crossing tracks are seen through the clear sea water like the ruts upon a wintry road, and the oar leaves blue gashes upon the ground at every stroke, or is entangled among the thick weed that fringes the banks with the weight of its sullen waves, leaning to and fro upon the uncertain sway of the exhausted tide. The scene is often profoundly oppressive, even at this day, when every plot of higher ground bears some fragment of fair building: but, in order to know what it was once, let the traveller follow in his boat at evening the windings of some unfrequented channel far into the midst of the melancholy plain; let him remove, in his imagination, the brightness of the great city that still extends itself in the distance, and the walls and towers from the islands that are near; and so wait, until the bright investiture and sweet warmth of the sunset are withdrawn from the waters, and the black desert of their shore lies in its nakedness beneath the night, pathless, comfortless, infirm, lost in dark languor and fearful silence, except where the salt runlets splash into the tideless pools, or the seabirds flit from their margins with a questioning cry; and he will be enabled to enter in some sort into the horror of heart with which this solitude was anciently chosen by man for his habitation. They little thought, who

first drove the stakes into the sand, and strewed the ocean reeds for their rest, that their children were to be the princes of that ocean, and their palaces its pride; and yet, in the great natural laws that rule that sorrowful wilderness, let it be remembered what strange preparation had been made for the things which no human imagination could have foretold, and how the whole existence and fortune of the Venetian nation were anticipated or compelled, by the setting of those bars and doors to the rivers and the sea. Had deeper currents divided their islands, hostile navies would again and again have reduced the rising city into servitude; had stronger surges beaten their shores, all the richness and refinement of the Venetian architecture must have been exchanged for the walls and bulwarks of an ordinary sea-port. Had there been no tide, as in other parts of the Mediterranean, the narrow canals of the city would have become noisome, and the marsh in which it was built pestiferous. Had the tide been only a foot or eighteen inches higher in its rise, the water-access to the doors of the palaces would have been impossible: even as it is, there is sometimes a little difficulty, at the ebb, in landing without setting foot upon the lower and slippery steps: and the highest tides sometimes enter the courtyards, and overflow the entrance halls. Eighteen inches more of difference between the level of the flood and ebb would have rendered the doorsteps of every palace, at low water, a treacherous mass of weeds and limpets, and the entire system of water-carriage for the higher classes, in their easy and daily intercourse, must have been done away with. The streets of the city would have been widened, its network of canals filled up, and all the peculiar character of the place and the people destroyed.

§ VII. The reader may perhaps have felt some pain in the contrast between this faithful view of the site of the Venetian Throne, and the romantic conception of it which we ordinarily form; but this pain, if he have felt it, ought to be more than counterbalanced by the value of the instance thus afforded to us at once of the inscrutableness and the wisdom of the ways of God. If, two thousand years ago, we had been permitted

to watch the slow settling of the slime of those turbid rivers into the polluted sea, and the gaining upon its deep and fresh waters of the lifeless, impassable, unvoyageable plain, how little could we have understood the purpose with which those islands were shaped out of the void, and the torpid waters enclosed with their desolate walls of sand! How little could we have known, any more than of what now seems to us most distressful, dark, and objectless, the glorious aim which was then in the mind of Him in whose hand are all the corners of the earth! how little imagined that in the laws which were stretching forth the gloomy margins of those fruitless banks, and feeding the bitter grass among their shallows, there was indeed a preparation, and *the only preparation possible*, for the founding of a city which was to be set like a golden clasp on the girdle of the earth, to write her history on the white scrolls of the sea-surges, and to word it in their thunder, and to gather and give forth, in world-wide pulsation, the glory of the West and of the East, from the burning heart of her Fortitude and Splendor.

CHAPTER II.

TORCELLO.

§ 1. SEVEN miles to the north of Venice, the banks of sand, which near the city rise little above low-water mark, attain by degrees a higher level, and knit themselves at last into fields of salt morass, raised here and there into shapeless mounds, and intercepted by narrow creeks of sea. One of the feeblest of these inlets, after winding for some time among buried fragments of masonry, and knots of sunburnt weeds whitened with webs of fucus, stays itself in an utterly stagnant pool beside a plot of greener grass covered with ground ivy and violets. On this mound is built a rude brick campanile, of the commonest Lombardic type, which if we ascend towards evening (and there are none to hinder us, the door of its ruinous staircase swinging idly on its hinges), we may command from it one of the most notable scenes in this wide world of ours.

Far as the eye can reach, a waste of wild sea moor, of a lurid ashen grey ; not like our northern moors with their jet-black pools and purple heath, but lifeless, the color of sackcloth, with the corrupted sea-water soaking through the roots of its acrid weeds, and gleaming hither and thither through its snaky channels. No gathering of fantastic mists, nor coursing of clouds across it ; but melancholy clearness of space in the warm sunset, oppressive, reaching to the horizon of its level gloom. To the very horizon, on the north-east ; but, to the north and west, there is a blue line of higher land along the border of it, and above this, but farther back, a misty band of mountains, touched with snow. To the east, the paleness and roar of the Adriatic, louder at momentary intervals as the surf breaks on the bars of sand ; to the south, the widening branches of the calm lagoon, alternately purple and pale green, as they reflect the evening clouds or twilight sky ; and almost beneath our feet, on the same field which sustains the tower we gaze from, a group of four buildings, two of them little larger than cottages (though built of stone, and one adorned by a quaint belfry), the third an octagonal chapel, of which we can see but little more than the flat red roof with its rayed tiling, the fourth, a considerable church with nave and aisles, but of which, in like manner, we can see little but the long central ridge and lateral slopes of roof, which the sunlight separates in one glowing mass from the green field beneath and grey moor beyond. There are no living creatures near the buildings, nor any vestige of village or city round about them. They lie like a little company of ships becalmed on a far-away sea.

§ II. Then look farther to the south. Beyond the widening branches of the lagoon, and rising out of the bright lake into which they gather, there are a multitude of towers, dark, and scattered among square-set shapes of clustered palaces, a long and irregular line fretting the southern sky.

Mother and daughter, you behold them both in their widowhood,—TORCELLO and VENICE.

Thirteen hundred years ago, the grey moorland looked as it does this day, and the purple mountains stood as radiantly

in the deep distances of evening ; but on the line of the horizon, there were strange fires mixed with the light of sunset, and the lament of many human voices mixed with the fretting of the waves on their ridges of sand. The flames rose from the ruins of Altinum ; the lament from the multitude of its people, seeking, like Israel of old, a refuge from the sword in the paths of the sea.

The cattle are feeding and resting upon the site of the city that they left ; the mower's scythe swept this day at dawn over the chief street of the city that they built, and the swathes of soft grass are now sending up their scent into the night air, the only incense that fills the temple of their ancient worship. Let us go down into that little space of meadow land.

§ III. The inlet which runs nearest to the base of the campanile is not that by which Torcello is commonly approached. Another, somewhat broader, and overhung by alder copse, winds out of the main channel of the lagoon up to the very edge of the little meadow which was once the Piazza of the city, and there, stayed by a few grey stones which present some semblance of a quay, forms its boundary at one extremity. Hardly larger than an ordinary English farmyard, and roughly enclosed on each side by broken palings and hedges of honeysuckle and briar, the narrow field retires from the water's edge, traversed by a scarcely traceable footpath, for some forty or fifty paces, and then expanding into the form of a small square, with buildings on three sides of it, the fourth being that which opens to the water. Two of these, that on our left and that in front of us as we approach from the canal, are so small that they might well be taken for the out-houses of the farm, though the first is a conventual building, and the other aspires to the title of the "Palazzo publico," both dating as far back as the beginning of the fourteenth century ; the third, the octagonal church of Santa Fosca, is far more ancient than either, yet hardly on a larger scale. Though the pillars of the portico which surrounds it are of pure Greek marble, and their capitals are enriched with delicate sculpture, they, and the arches they sustain, together only raise the roof to the height of a cattle-shed ; and the first

strong impression which the spectator receives from the whole scene is, that whatever sin it may have been which has on this spot been visited with so utter a desolation, it could not at least have been ambition. Nor will this impression be diminished as we approach, or enter, the larger church to which the whole group of building is subordinate. It has evidently been built by men in flight and distress,* who sought in the hurried erection of their island church such a shelter for their earnest and sorrowful worship as, on the one hand, could not attract the eyes of their enemies by its splendor, and yet, on the other, might not awaken too bitter feelings by its contrast with the churches which they had seen destroyed. There is visible everywhere a simple and tender effort to recover some of the form of the temples which they had loved, and to do honor to God by that which they were erecting, while distress and humiliation prevented the desire, and prudence precluded the admission, either of luxury of ornament or magnificence of plan. The exterior is absolutely devoid of decoration, with the exception only of the western entrance and the lateral door, of which the former has carved sideposts and architrave, and the latter, crosses of rich sculpture; while the massy stone shutters of the windows, turning on huge rings of stone, which answer the double purpose of stanchions and brackets, cause the whole building rather to resemble a refuge from Alpine storm than the cathedral of a populous city; and, internally, the two solemn mosaics of the eastern and western extremities,—one representing the Last Judgment, the other the Madonna, her tears falling as her hands are raised to bless,—and the noble range of pillars which enclose the space between, terminated by the high throne for the pastor and the semicircular raised seats for the superior clergy, are expressive at once of the deep sorrow and the sacred courage of men who had no home left them upon earth, but who looked for one to come, of men “persecuted but not forsaken, cast down but not destroyed.”

§ iv. I am not aware of any other early church in Italy which has this peculiar expression in so marked a degree; and

* Appendix 4, “Date of the Duomo of Torcello.”

it is so consistent with all that Christian architecture ought to express in every age (for the actual condition of the exiles who built the cathedral of Torcello is exactly typical of the spiritual condition which every Christian ought to recognize in himself, a state of homelessness on earth, except so far as he can make the Most High his habitation), that I would rather fix the mind of the reader on this general character than on the separate details, however interesting, of the architecture itself. I shall therefore examine these only so far as is necessary to give a clear idea of the means by which the peculiar expression of the building is attained.

§ v. On the opposite page, the uppermost figure, 1, is a rude plan of the church. I do not answer for the thickness and external disposition of the walls, which are not to our present purpose, and which I have not carefully examined; but the interior arrangement is given with sufficient accuracy. The church is built on the usual plan of the Basilica* that is to say, its body divided into a nave and aisles by two rows of massive shafts, the roof of the nave being raised high above the aisles by walls sustained on two ranks of pillars, and pierced with small arched windows. At Torcello the aisles are also lighted in the same manner, and the nave is nearly twice their breadth.†

The capitals of all the great shafts are of white marble, and are among the best I have ever seen, as examples of perfectly calculated effect from every touch of the chisel. Mr. Hope calls them "indifferently imitated from the Corinthian:" ‡ but the expression is as inaccurate as it is unjust; every one of them is different in design, and their variations are as graceful as they are fanciful. I could not, except by an elaborate

* For a full account of the form and symbolical meaning of the Basilica, see Lord Lindsay's "Christian Art," vol. i. p. 12. It is much to be regretted that the Chevalier Bunsen's work on the Basilicas of Rome is not translated into English.

† The measures are given in Appendix 3.

‡ Hope's "Historical Essay on Architecture" (third edition, 1840), chap. ix. p. 95. In other respects Mr. Hope has done justice to this building and to the style of the early Christian churches in general.

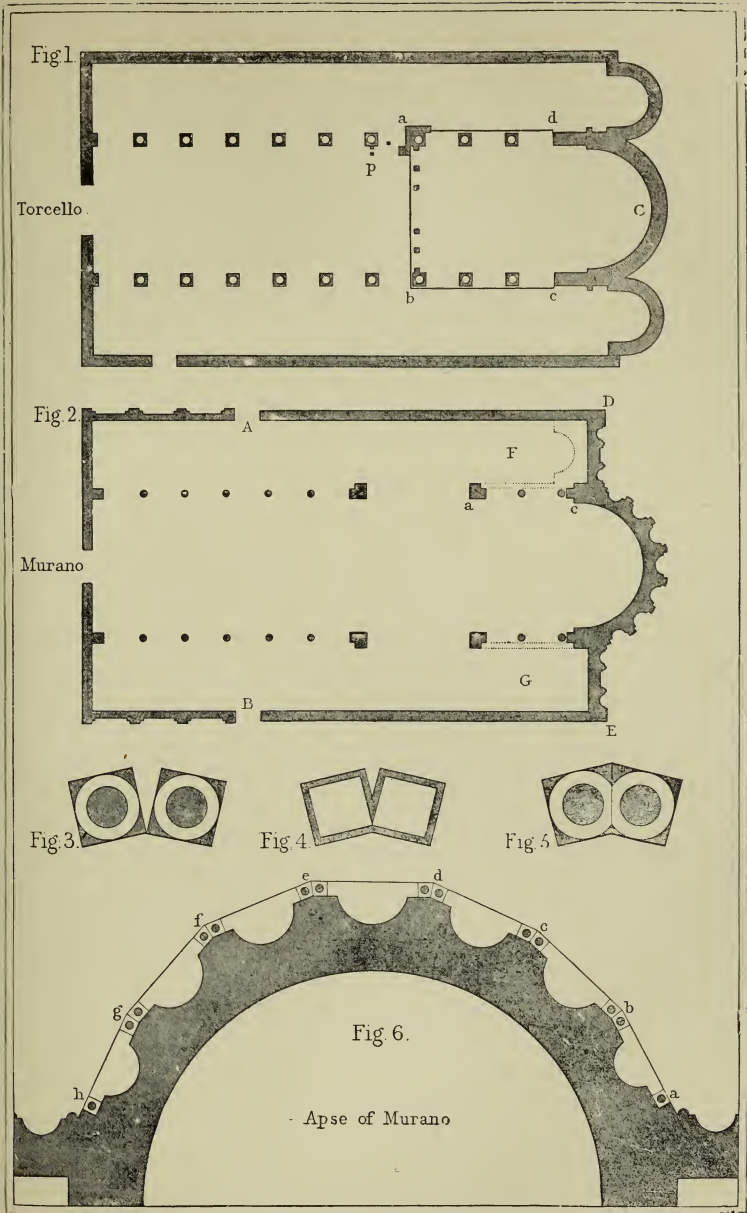
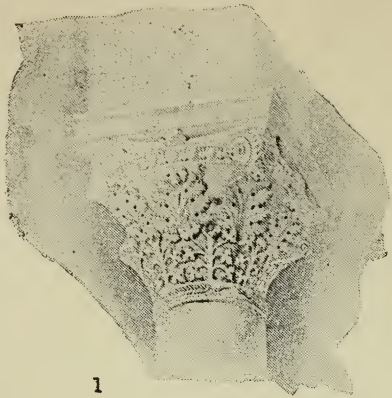
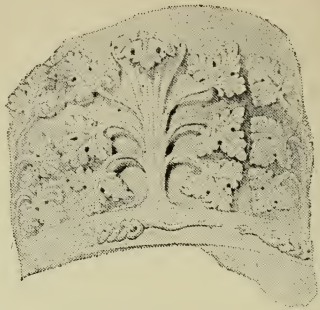

PLATE I.—PLANS OF TORCELLO AND MURANO.



1



2

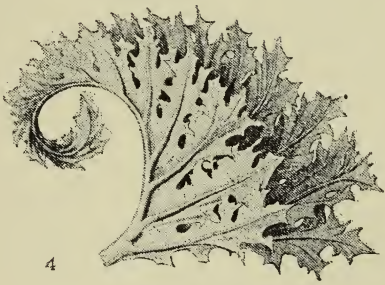

4



3



5

PLATE II.—THE ACANTHUS OF TORCELLO.

drawing, give any idea of the sharp, dark, deep penetrations of the chisel into their snowy marble, but a single example is given in the opposite plate, fig. 1, of the nature of the changes effected in them from the Corinthian type. In this capital, although a kind of acanthus (only with rounded lobes) is indeed used for the upper range of leaves, the lower range is not acanthus at all, but a kind of vine, or at least that species of plant which stands for vine in all early Lombardic and Byzantine work (vide Vol. I. Appendix 8); the leaves are trefoiled, and the stalks cut clear so that they might be grasped with the hand, and cast sharp dark shadows, perpetually changing, across the bell of the capital behind them. I have drawn one of those vine plants larger in fig. 2, that the reader may see how little imitation of the Corinthian there is in them, and how boldly the stems of the leaves are detached from the ground. But there is another circumstance in this ornament still more noticeable. The band which encircles the shaft beneath the spring of the leaves is copied from the common classical wreathed or braided fillet, of which the reader may see examples on almost every building of any pretensions in modern London. But the mediæval builders could not be content with the dead and meaningless scroll: the Gothic energy and love of life, mingled with the early Christian religious symbolism, were struggling daily into more vigorous expression, and they turned the wreathed band into a serpent of three times the length necessary to undulate round the shaft, which, knotting itself into a triple chain, shows at one side of the shaft its tail and head, as if perpetually gliding round it beneath the stalks of the vines. The vine, as is well known, was one of the early symbols of Christ, and the serpent is here typical either of the eternity of his dominion, or of the Satanic power subdued.



FIG. 1.

§ VI. Nor even when the builder confines himself to the acanthus leaf (or to that representation of it, hereafter to be more particularly examined, constant in Romanesque work) can his imagination allow him to rest content with its accustomed position. In a common Corinthian capital the leaves

nod forward only, thrown out on every side from the bell which they surround : but at the base of one of the capitals on the opposite side of the nave from this of the vines,* two leaves are introduced set with their sides outwards, forming spirals by curling back, half-closed, in the position shown in fig. 4 in Plate II., there represented as in a real acanthus leaf ; for it will assist our future inquiries into the ornamentation of capitals that the reader should be acquainted with the form of the acanthus leaf itself. I have drawn it, therefore, in the two positions, figs. 3 and 4 in Plate II. ; while fig. 5 is the translation of the latter form into marble by the sculptor of Torcello. It is not very like the acanthus, but much liker than any Greek work ; though still entirely conventional in its cinquefoiled lobes. But these are disposed with the most graceful freedom of line, separated at the roots by deep drill holes, which tell upon the eye far away like beads of jet ; and changed, before they become too crowded to be effective, into a vigorous and simple zigzagged edge, which saves the designer some embarrassment in the perspective of the terminating spiral. But his feeling of nature was greater than his knowledge of perspective ; and it is delightful to see how he has rooted the whole leaf in the strong rounded under-stem, the indication of its closing with its face inwards, and has thus given organization and elasticity to the lovely group of spiral lines ; a group of which, even in the lifeless sea-shell, we are never weary, but which becomes yet more delightful when the ideas of elasticity and growth are joined to the sweet succession of its involution.

§ VII. It is not, however, to be expected that either the mute language of early Christianity (however important a part of the expression of the building at the time of its erection), or the delicate fancies of the Gothic leafage springing into new life, should be read, or perceived, by the passing traveller who has never been taught to expect anything in architecture except five orders : yet he can hardly fail to be struck by the simplicity and dignity of the great shafts themselves ; by the frank diffusion of light, which prevents their severity

* A sketch has been given of this capital in my folio work.

from becoming oppressive; by the delicate forms and lovely carving of the pulpit and chancel screen; and, above all, by the peculiar aspect of the eastern extremity of the church, which, instead of being withdrawn, as in later cathedrals, into a chapel dedicated to the Virgin, or contributing by the brilliancy of its windows to the splendor of the altar, and theatrical effect of the ceremonies performed there, is a simple and stern semicircular recess, filled beneath by three ranks of seats, raised one above the other, for the bishop and presbyters, that they might watch as well as guide the devotions of the people, and discharge literally in the daily service the functions of bishops or *overseers* of the flock of God.

§ VIII. Let us consider a little each of these characters in succession; and first (for of the shafts enough has been said already), what is very peculiar to this church, its luminousness. This perhaps strikes the traveller more from its contrast with the excessive gloom of the Church of St. Mark's; but it is remarkable when we compare the Cathedral of Torcello with any of the contemporary basilicas in South Italy or Lombardic churches in the North. St. Ambrogio at Milan, St. Michele at Pavia, St. Zeno at Verona, St. Frediano at Lucca, St. Miniato at Florence, are all like sepulchral caverns compared with Torcello, where the slightest details of the sculptures and mosaics are visible, even when twilight is deepening. And there is something especially touching in our finding the sunshine thus freely admitted into a church built by men in sorrow. They did not need the darkness; they could not perhaps bear it. There was fear and depression upon them enough, without a material gloom. They sought for comfort in their religion, for tangible hopes and promises, not for threatenings or mysteries; and though the subjects chosen for the mosaics on the walls are of the most solemn character, there are no artificial shadows cast upon them, nor dark colors used in them: all is fair and bright, and intended evidently to be regarded in hopefulness, and not with terror.

§ IX. For observe this choice of subjects. It is indeed possible that the walls of the nave and aisles, which are now

whitewashed, may have been covered with fresco or mosaic, and thus have supplied a series of subjects, on the choice of which we cannot speculate. I do not, however, find record of the destruction of any such works; and I am rather inclined to believe that at any rate the central division of the building was originally decorated, as it is now, simply by mosaics representing Christ, the Virgin, and the apostles, at one extremity, and Christ coming to judgment at the other. And if so, I repeat, observe the significance of this choice. Most other early churches are covered with imagery sufficiently suggestive of the vivid interest of the builders in the history and occupations of the world. Symbols or representations of political events, portraits of living persons, and sculptures of satirical, grotesque, or trivial subjects are of constant occurrence, mingled with the more strictly appointed representations of scriptural or ecclesiastical history; but at Torcello even these usual, and one should have thought almost necessary, successions of Bible events do not appear. The mind of the worshipper was fixed entirely upon two great facts, to him the most precious of all facts,—the present mercy of Christ to His Church, and His future coming to judge the world. That Christ's mercy was, at this period, supposed chiefly to be attainable through the pleading of the Virgin, and that therefore beneath the figure of the Redeemer is seen that of the weeping Madonna in the act of intercession, may indeed be matter of sorrow to the Protestant beholder, but ought not to blind him to the earnestness and singleness of the faith with which these men sought their sea-solitudes; not in hope of founding new dynasties, or entering upon new epochs of prosperity, but only to humble themselves before God, and to pray that in His infinite mercy He would hasten the time when the sea should give up the dead which were in it, and Death and Hell give up the dead which were in them, and when they might enter into the better kingdom, "where the wicked cease from troubling and the weary are at rest."

§ x. Nor were the strength and elasticity of their minds, even in the least matters, diminished by thus looking forward to the close of all things. On the contrary, nothing is more

remarkable than the finish and beauty of all the portions of the building, which seem to have been actually executed for the place they occupy in the present structure. The rudest are those which they brought with them from the mainland ; the best and most beautiful, those which appear to have been carved for their island church : of these, the new capitals already noticed, and the exquisite panel ornaments of the chancel screen, are the most conspicuous ; the latter form a low wall across the church between the six small shafts whose places are seen in the plan, and serve to enclose a space raised two steps above the level of the nave, destined for the singers, and indicated also in the plan by an open line *a b c d*. The bas-reliefs on this low screen are groups of peacocks and lions, two face to face on each panel, rich and fantastic beyond description, though not expressive of very accurate knowledge either of leonine or pavonine forms. And it is not until we pass to the back of the stair of the pulpit, which is connected with the northern extremity of this screen, that we find evidence of the haste with which the church was constructed.

§ xi. The pulpit, however, is not among the least noticeable of its features. It is sustained on the four small detached shafts marked at *p* in the plan, between the two pillars at the north side of the screen ; both pillars and pulpit studiously plain, while the staircase which ascends to it is a compact mass of masonry (shaded in the plan), faced by carved slabs of marble ; the parapet of the staircase being also formed of solid blocks like paving-stones, lightened by rich, but not deep, exterior carving. Now these blocks, or at least those which adorn the staircase towards the aisle, have been brought from the mainland ; and, being of size and shape not easily to be adjusted to the proportions of the stair, the architect has cut out of them pieces of the size he needed, utterly regardless of the subject or symmetry of the original design. The pulpit is not the only place where this rough procedure has been permitted : at the lateral door of the church are two crosses, cut out of slabs of marble, formerly covered with rich sculpture over their whole surfaces, of

which portions are left on the surface of the crosses ; the lines of the original design being, of course, just as arbitrarily cut by the incisions between the arms, as the patterns upon a piece of silk which has been shaped anew. The fact is, that in all early Romanesque work, large surfaces are covered with sculpture for the sake of enrichment only ; sculpture which indeed had always meaning, because it was easier for the sculptor to work with some chain of thought to guide his chisel, than without any ; but it was not always intended, or at least not always hoped, that this chain of thought might be traced by the spectator. All that was proposed appears to have been the enrichment of surface, so as to make it delightful to the eye ; and this being once understood, a decorated piece of marble became to the architect just what a piece of lace or embroidery is to a dressmaker, who takes of it such portions as she may require, with little regard to the places where the patterns are divided. And though it may appear, at first sight, that the procedure is indicative of bluntness and rudeness of feeling, we may perceive, upon reflection, that it may also indicate the redundancy of power which sets little price upon its own exertion. When a barbarous nation builds its fortress-walls out of fragments of the refined architecture it has overthrown, we can read nothing but its savageness in the vestiges of art which may thus chance to have been preserved ; but when the new work is equal, if not superior, in execution, to the pieces of the older art which are associated with it, we may justly conclude that the rough treatment to which the latter have been subjected is rather a sign of the hope of doing better things, than of want of feeling for those already accomplished. And, in general, this careless fitting of ornament is, in very truth, an evidence of life in the school of builders, and of their making a due distinction between work which is to be used for architectural effect, and work which is to possess an abstract perfection ; and it commonly shows also that the exertion of design is so easy to them, and their fertility so inexhaustible, that they feel no remorse in using somewhat injuriously what they can replace with so slight an effort.

§ XII. It appears however questionable in the present instance, whether, if the marbles had not been carved to *his* hand, the architect would have taken the trouble to enrich them. For the execution of the rest of the pulpit is studiously simple, and it is in this respect that its design possesses, it seems to me, an interest to the religious spectator greater than he will take in any other portion of the building. It is supported, as I said, on a group of four slender shafts; itself of a slightly oval form, extending nearly from one pillar of the nave to the next, so as to give the preacher free room for the action of the entire person, which always gives an unaffected impressiveness to the eloquence of the southern nations. In the centre of its curved front, a small bracket and detached shaft sustain the projection of a narrow marble desk (occupying the place of a cushion in a modern pulpit), which is hollowed out into a shallow curve on the upper surface, leaving a ledge at the bottom of the slab, so that a book laid upon it, or rather into it, settles itself there, opening as if by instinct, but without the least chance of slipping to the side, or in any way moving beneath the preacher's hands.* Six balls, or rather almonds, of purple marble veined with white are set round the edge of the pulpit, and form its only decoration. Perfectly graceful, but severe and almost cold in its simplicity, built for permanence and service, so that no single member, no stone of it, could be spared, and yet all are firm and uninjured as when they were first set together, it stands in venerable contrast both with the fantastic pulpits of mediæval cathedrals and with the rich furniture of those of our modern churches. It is worth while pausing for a moment to consider how far the manner of decorating a pulpit may have influence on the efficiency of its service, and whether our modern treatment of this, to us all-important, feature of a church be the best possible.

§ XIII. When the sermon is good we need not much concern ourselves about the form of the pulpit. But sermons cannot always be good; and I believe that the temper in which the congregation set themselves to listen may be in some degree

* Appendix 5, "Modern Pulpits."

modified by their perception of fitness or unfitness, impressiveness or vulgarity, in the disposition of the place appointed for the speaker,—not to the same degree, but somewhat in the same way, that they may be influenced by his own gestures or expression, irrespective of the sense of what he says. I believe, therefore, in the first place, that pulpits ought never to be highly decorated; the speaker is apt to look mean or diminutive if the pulpit is either on a very large scale or covered with splendid ornament, and if the interest of the sermon should flag the mind is instantly tempted to wander. I have observed that in almost all cathedrals, when the pulpits are peculiarly magnificent, sermons are not often preached from them; but rather, and especially if for any important purpose, from some temporary erection in other parts of the building: and though this may often be done because the architect has consulted the effect upon the eye more than the convenience of the ear in the placing of his larger pulpit, I think it also proceeds in some measure from a natural dislike in the preacher to match himself with the magnificence of the rostrum, lest the sermon should not be thought worthy of the place. Yet this will rather hold of the colossal sculptures, and pyramids of fantastic tracery which encumber the pulpits of Flemish and German churches, than of the delicate mosaics and ivory-like carving of the Romanesque basilicas, for when the form is kept simple, much loveliness of color and costliness of work may be introduced, and yet the speaker not be thrown into the shade by them.

§ xiv. But, in the second place, whatever ornaments we admit ought clearly to be of a chaste, grave, and noble kind; and what furniture we employ, evidently more for the honoring of God's word than for the ease of the preacher. For there are two ways of regarding a sermon, either as a human composition, or a Divine message. If we look upon it entirely as the first, and require our clergymen to finish it with their utmost care and learning, for our better delight whether of ear or intellect, we shall necessarily be led to expect much formality and stateliness in its delivery, and to think that all is not well if the pulpit have not a golden fringe round it,

and a goodly cushion in front of it, and if the sermon be not fairly written in a black book, to be smoothed upon the cushion in a majestic manner before beginning; all this we shall duly come to expect: but we shall at the same time consider the treatise thus prepared as something to which it is our duty to listen without restlessness for half an hour or three quarters, but which, when that duty has been decorously performed, we may dismiss from our minds in happy confidence of being provided with another when next it shall be necessary. But if once we begin to regard the preacher, whatever his faults, as a man sent with a message to us, which it is a matter of life or death whether we hear or refuse; if we look upon him as set in charge over many spirits in danger of ruin, and having allowed to him but an hour or two in the seven days to speak to them; if we make some endeavor to conceive how precious these hours ought to be to him, a small vantage on the side of God after his flock have been exposed for six days together to the full weight of the world's temptation, and he has been forced to watch the thorn and the thistle springing in their hearts, and to see what wheat had been scattered there snatched from the wayside by this wild bird and the other, and at last, when breathless and weary with the week's labor they give him this interval of imperfect and languid hearing, he has but thirty minutes to get at the separate hearts of a thousand men, to convince them of all their weaknesses, to shame them for all their sins, to warn them of all their dangers, to try by this way and that to stir the hard fastenings of those doors where the Master himself has stood and knocked yet none opened, and to call at the openings of those dark streets where Wisdom herself hath stretched forth her hands and no man regarded,—thirty minutes to raise the dead in,—let us but once understand and feel this, and we shall look with changed eyes upon that frippery of gay furniture about the place from which the message of judgment must be delivered, which either breathes upon the dry bones that they may live, or, if ineffectual, remains recorded in condemnation, perhaps against the utterer and listener alike, but assuredly against one of them. We

shall not so easily bear with the silk and gold upon the seat of judgment, nor with ornament of oratory in the mouth of the messenger : we shall wish that his words may be simple, even when they are sweetest, and the place from which he speaks like a marble rock in the desert, about which the people have gathered in their thirst.

§ xv. But the severity which is so marked in the pulpit at Torcello is still more striking in the raised seats and episcopal throne which occupy the curve of the apse. The arrangement at first somewhat recalls to the mind that of the Roman amphitheatres ; the flight of steps which lead up to the central throne divides the curve of the continuous steps or seats (it appears in the first three ranges questionable which were intended, for they seem too high for the one, and too low and close for the other), exactly as in an amphitheatre the stairs for access intersect the sweeping ranges of seats. But in the very rudeness of this arrangement, and especially in the want of all appliances of comfort (for the whole is of marble, and the arms of the central throne are not for convenience, but for distinction, and to separate it more conspicuously from the undivided seats), there is a dignity which no furniture of stalls nor carving of canopies ever could attain, and well worth the contemplation of the Protestant, both as sternly significative of an episcopal authority which in the early days of the Church was never disputed, and as dependent for all its impressiveness on the utter absence of any expression either of pride or self-indulgence.

§ xvi. But there is one more circumstance which we ought to remember as giving peculiar significance to the position which the episcopal throne occupies in this island church, namely, that in the minds of all early Christians the Church itself was most frequently symbolized under the image of a ship, of which the bishop was the pilot. Consider the force which this symbol would assume in the imaginations of men to whom the spiritual Church had become an ark of refuge in the midst of a destruction hardly less terrible than that from which the eight souls were saved of old, a destruction in which the wrath of man had become as broad as the earth and as

merciless as the sea, and who saw the actual and literal edifice of the Church raised up, itself like an ark in the midst of the waters. No marvel if with the surf of the Adriatic rolling between them and the shores of their birth, from which they were separated for ever, they should have looked upon each other as the disciples did when the storm came down on the Tiberias Lake, and have yielded ready and loving obedience to those who ruled them in His name, who had there rebuked the winds and commanded stillness to the sea. And if the stranger would yet learn in what spirit it was that the dominion of Venice was begun, and in what strength she went forth conquering and to conquer, let him not seek to estimate the wealth of her arsenals or number of her armies, nor look upon the pageantry of her palaces, nor enter into the secrets of her councils ; but let him ascend the highest tier of the stern ledges that sweep round the altar of Torcello, and then, looking as the pilot did of old along the marble ribs of the goodly temple-ship, let him repeople its veined deck with the shadows of its dead mariners, and strive to feel in himself the strength of heart that was kindled within them, when first, after the pillars of it had settled in the sand, and the roof of it had been closed against the angry sky that was still reddened by the fires of their homesteads,—first, within the shelter of its knitted walls, amidst the murmur of the waste of waves and the beating of the wings of the sea-birds round the rock that was strange to them,—rose that ancient hymn, in the power of their gathered voices :

THE SEA IS HIS, AND HE MADE IT :

AND HIS HANDS PREPARED THE DRY LAND.

CHAPTER III.

MURANO.

§ I. THE decay of the city of Venice is, in many respects, like that of an outwearied and aged human frame ; the cause of its decrepitude is indeed at the heart, but the outward appearances of it are first at the extremities. In the centre of

the city there are still places where some evidence of vitality remains, and where, with kind closing of the eyes to signs, too manifest even there, of distress and declining fortune, the stranger may succeed in imagining, for a little while, what must have been the aspect of Venice in her prime. But this lingering pulsation has not force enough any more to penetrate into the suburbs and outskirts of the city; the frost of death has there seized upon it irrevocably, and the grasp of mortal disease is marked daily by the increasing breadth of its belt of ruin. Nowhere is this seen more grievously than along the great north-eastern boundary, once occupied by the smaller palaces of the Venetians, built for pleasure or repose; the nobler piles along the grand canal being reserved for the pomp and business of daily life. To such smaller palaces some garden ground was commonly attached, opening to the water-side; and, in front of these villas and gardens, the lagoon was wont to be covered in the evening by gondolas: the space of it between this part of the city and the island group of Murano being to Venice, in her time of power, what its parks are to London; only gondolas were used instead of carriages, and the crowd of the population did not come out till towards sunset, and prolonged their pleasures far into the night, company answering to company with alternate singing.

§ II. If, knowing this custom of the Venetians, and with a vision in his mind of summer palaces lining the shore, and myrtle gardens sloping to the sea, the traveller now seeks this suburb of Venice, he will be strangely and sadly surprised to find a new but perfectly desolate quay, about a mile in length, extending from the arsenal to the Sacca della Misericordia, in front of a line of miserable houses built in the course of the last sixty or eighty years, yet already tottering to their ruin; and not less to find that the principal object in the view which these houses (built partly in front and partly on the ruins of the ancient palaces) now command is a dead brick wall about a quarter of a mile across the water, interrupted only by a kind of white lodge, the cheerfulness of which prospect is not enhanced by his finding that this wall encloses the principal public cemetery of Venice. He may, perhaps, marvel for a

few moments at the singular taste of the old Venetians in taking their pleasure under a churchyard wall : but, on further inquiry, he will find that the building on the island, like those on the shore, is recent, that it stands on the ruins of the Church of St. Cristoforo della Pace ; and that with a singular, because unintended, moral, the modern Venetians have replaced the Peace of the Christ-bearer by the Peace of Death, and where they once went, as the sun set daily, to their pleasure, now go, as the sun sets to each of them for ever, to their graves.

§ III. Yet the power of Nature cannot be shortened by the folly, nor her beauty altogether saddened by the misery, of man. The broad tides still ebb and flow brightly about the island of the dead, and the linked conclave of the Alps know no decline from their old pre-eminence, nor stoop from their golden thrones in the circle of the horizon. So lovely is the scene still, in spite of all its injuries, that we shall find ourselves drawn there again and again at evening out of the narrow canals and streets of the city, to watch the wreaths of the sea-mists weaving themselves like mourning veils around the mountains far away, and listen to the green waves as they fret and sigh along the cemetery shore.

§ IV. But it is morning now : we have a hard day's work to do at Murano, and our boat shoots swiftly from beneath the last bridge of Venice, and brings us out into the open sea and sky.

The pure cumuli of cloud lie crowded and leaning against one another, rank beyond rank, far over the shining water, each cut away at its foundation by a level line, trenchant and clear, till they sink to the horizon like a flight of marble steps, except where the mountains meet them, and are lost in them, barred across by the grey terraces of those cloud foundations, and reduced into one crestless bank of blue, spotted here and there with strange flakes of wan, aerial, greenish light, strewed upon them like snow. And underneath is the long dark line of the mainland, fringed with low trees ; and then the wide-waving surface of the burnished lagoon trembling slowly, and shaking out into forked bands of lengthening light the images

of the towers of cloud above. To the north, there is first the great cemetery wall, then the long stray buildings of Murano, and the island villages beyond, glittering in intense crystalline vermilion, like so much jewellery scattered on a mirror, their towers poised apparently in the air a little above the horizon, and their reflections, as sharp and vivid and substantial as themselves, thrown on the vacancy between them and the sea. And thus the villages seem standing on the air ; and, to the east, there is a cluster of ships that seem sailing on the land ; for the sandy line of the Lido stretches itself between us and them, and we can see the tall white sails moving beyond it, but not the sea, only there is a sense of the great sea being indeed there, and a solemn strength of gleaming light in sky above.

§ v. The most discordant feature in the whole scene is the cloud which hovers above the glass furnaces of Murano ; but this we may not regret, as it is one of the last signs left of human exertion among the ruinous villages which surround us. The silent gliding of the gondola brings it nearer to us every moment ; we pass the cemetery, and a deep sea-channel which separates it from Murano, and finally enter a narrow water-street, with a paved footpath on each side, raised three or four feet above the canal, and forming a kind of quay between the water and the doors of the houses. These latter are, for the most part, low, but built with massy doors and windows of marble or Istrian stone, square-set and barred with iron ; buildings evidently once of no mean order, though now inhabited only by the poor. Here and there an ogee window of the fourteenth century, or a doorway deeply enriched with cable mouldings, shows itself in the midst of more ordinary features ; and several houses, consisting of one story only carried on square pillars, forming a short arcade along the quay, have windows sustained on shafts of red Verona marble, of singular grace and delicacy. All now in vain : little care is there for their delicacy or grace among the rough fishermen sauntering on the quay with their jackets hanging loose from their shoulders, jacket and cap and hair all of the same dark-greenish sea-grey. But there is some life in the scene, more

than is usual in Venice: the women are sitting at their doors knitting busily, and various workmen of the glass-houses sifting glass dust upon the pavement, and strange cries coming from one side of the canal to the other, and ringing far along the crowded water, from venders of figs and grapes, and gourds and shell-fish; cries partly descriptive of the eatables in question, but interspersed with others of a character unintelligible in proportion to their violence, and fortunately so if we may judge by a sentence which is stencilled in black, within a garland, on the whitewashed walls of nearly every other house in the street, but which, how often soever written, no one seems to regard: "Bestemme non più. Lodate Gesù."

§ VI. We push our way on between large barges laden with fresh water from Fusina, in round white tubs seven feet across, and complicated boats full of all manner of nets that look as if they could never be disentangled, hanging from their masts and over their sides; and presently pass under a bridge with the lion of St. Mark on its archivolt, and another on a pillar at the end of the parapet, a small red lion with much of the puppy in his face, looking vacantly up into the air (in passing we may note that, instead of feathers, his wings are covered with hair, and in several other points the manner of his sculpture is not uninteresting). Presently the canal turns a little to the left, and thereupon becomes more quiet, the main bustle of the water-street being usually confined to the first straight reach of it, some quarter of a mile long, the Cheapside of Murano. We pass a considerable church on the left, St. Pietro, and a little square opposite to it with a few acacia trees, and then find our boat suddenly seized by a strong green eddy, and whirled into the tide-way of one of the main channels of the lagoon, which divides the town of Murano into two parts by a deep stream some fifty yards over, crossed only by one wooden bridge. We let ourselves drift some way down the current, looking at the low line of cottages on the other side of it, hardly knowing if there be more cheerfulness or melancholy in the way the sunshine glows on their ruinous but whitewashed walls, and sparkles on the rushing of the green water by the grass-grown quay. It needs a strong stroke of

the oar to bring us into the mouth of another quiet canal on the farther side of the tide-way, and we are still somewhat giddy when we run the head of the gondola into the sand on the left-hand side of this more sluggish stream, and land under the east end of the church of San Donato, the "Matrice" or "Mother" Church of Murano.

§ VII. It stands, it and the heavy campanile detached from it a few yards, in a small triangular field of somewhat fresher grass than is usual near Venice, traversed by a paved walk with green mosaic of short grass between the rude squares of its stones, bounded on one side by ruinous garden walls, on another by a line of low cottages, on the third, the base of the triangle, by the shallow canal from which we have just landed. Near the point of the triangular space is a simple well, bearing date 1502; in its widest part, between the canal and campanile, is a four-square hollow pillar, each side formed by a separate slab of stone, to which the iron hasps are still attached that once secured the Venetian standard.

The cathedral itself occupies the northern angle of the field, encumbered with modern buildings, small outhouse-like chapels, and wastes of white wall with blank square windows, and itself utterly defaced in the whole body of it, nothing but the apse having been spared; the original plan is only discoverable by careful examination, and even then but partially. The whole impression and effect of the building are irretrievably lost, but the fragments of it are still most precious.

We must first briefly state what is known of its history.

§ VIII. The legends of the Romish Church, though generally more insipid and less varied than those of Paganism, deserve audience from us on this ground, if on no other, that they have once been sincerely believed by good men, and have had no ineffective agency in the foundation of the existent European mind. The reader must not therefore accuse me of trifling, when I record for him the first piece of information I have been able to collect respecting the cathedral of Murano: namely, that the emperor Otho the Great, being overtaken by a storm on the Adriatic, vowed, if he were preserved, to build and dedicate a church to the Virgin, in whatever place might

be most pleasing to her ; that the storm thereupon abated ; and the Virgin appearing to Otho in a dream showed him, covered with red lilies, that very triangular field on which we were but now standing, amidst the ragged weeds and shattered pavement. The emperor obeyed the vision ; and the church was consecrated on the 15th of August, 957.

§ ix. Whatever degree of credence we may feel disposed to attach to this piece of history, there is no question that a church was built on this spot before the close of the tenth century : since in the year 999 we find the incumbent of the Basilica (note this word, it is of some importance) di Santa Maria Plebania di Murano taking an oath of obedience to the Bishop of the Altinat church, and engaging at the same time to give the said bishop his dinner on the Domenica in Albis, when the prelate held a confirmation in the mother church, as it was then commonly called, of Murano. From this period, for more than a century, I can find no records of any alterations made in the fabric of the church, but there exist very full details of the quarrels which arose between its incumbents and those of San Stefano, San Cipriano, San Salvatore, and the other churches of Murano, touching the due obedience which their less numerous or less ancient brotherhoods owed to St. Mary's.

These differences seem to have been renewed at the election of every new abbot by each of the fraternities, and must have been growing serious when the patriarch of Grado, Henry Dandolo, interfered in 1102, and, in order to seal a peace between the two principal opponents, ordered that the abbot of St. Stephen's should be present at the service in St. Mary's on the night of the Epiphany, and that the abbot of St. Mary's should visit him of St. Stephen's on St. Stephen's day ; and that then the two abbots "should eat apples and drink good wine together, in peace and charity."*

* "Mela, e buon vino, con pace e carità." Memorie Storiche de' Veneti Primi e Secondi, di Jacopo Filiassi (Padua, 1811), tom. iii. cap. 23. Perhaps, in the choice of the abbot's cheer, there was some occult reference to the verse of Solomon's Song : "Stay me with flagons, comfort me with apples."

§ x. But even this kindly effort seems to have been without result: the irritated pride of the antagonists remained unsoothed by the love-feast of St. Stephen's day; and the breach continued to widen until the abbot of St. Mary's obtained a timely accession to his authority in the year 1125. The Doge Domenico Michele, having in the second crusade secured such substantial advantages for the Venetians as might well counterbalance the loss of part of their trade with the East, crowned his successes by obtaining possession in Cephalonia of the body of St. Donato, bishop of Eurcea; which treasure he having presented on his return to the Murano basilica, that church was thenceforward called the church of Sts. Mary and Donato. Nor was the body of the saint its only acquisition: St. Donato's principal achievement had been the destruction of a terrible dragon in Epirus; Michele brought home the bones of the dragon as well as of the saint; the latter were put in a marble sarcophagus, and the former hung up over the high altar.

§ xi. But the clergy of St. Stefano were indomitable. At the very moment when their adversaries had received this formidable accession of strength, they had the audacity "ad onta de' replicati giuramenti, e dell' inveterata consuetudine,"* to refuse to continue in the obedience which they had vowed to their mother church. The matter was tried in a provincial council; the votaries of St. Stephen were condemned, and remained quiet for about twenty years, in wholesome dread of the authority conferred on the abbot of St. Donato, by the Pope's legate, to suspend any of the clergy of the island from their office if they refused submission. In 1172, however, they appealed to Pope Alexander III., and were condemned again: and we find the struggle renewed at every promising opportunity, during the course of the twelfth and thirteenth centuries; until at last, finding St. Donato and the dragon together too strong for him, the abbot of St. Stefano "discovered" in his church the bodies of two hundred martyrs at once!—a discovery, it is to be remembered, in some sort equivalent in those

* *Notizie Storiche delle Chiese di Venezia, illustrate da Flaminio Corner (Padua, 1758), p. 615.*

days to that of California in ours. The inscription, however, on the façade of the church, recorded it with quiet dignity :—
 “MCCCLXXIV. a di XIV. di Aprile. Furono trovati nella presente chiesa del protomartire San Stefano, duecento e più corpi de’ Santi Martiri, dal Ven. Prete Matteo Fradello, piovano della chiesa.” * Corner, who gives this inscription, which no longer exists, goes on to explain with infinite gravity, that the bodies in question, “being of infantile form and stature, are reported by tradition to have belonged to those fortunate innocents who suffered martyrdom under King Herod ; but that when, or by whom, the church was enriched with so vast a treasure, is not manifested by any document.” †

§ XII. The issue of the struggle is not to our present purpose. We have already arrived at the fourteenth century without finding record of any effort made by the clergy of St. Mary’s to maintain their influence by restoring or beautifying their basilica ; which is the only point at present of importance to us. That great alterations were made in it at the time of the acquisition of the body of St. Donato is however highly probable, the mosaic pavement of the interior, which bears its date inscribed, 1140, being probably the last of the additions. I believe that no part of the ancient church can be shown to be of more recent date than this ; and I shall not occupy the reader’s time by any inquiry respecting the epochs or authors of the destructive modern restorations ; the wreck of the old fabric, breaking out beneath them here and there, is generally distinguishable from them at a glance ; and it is enough for the reader to know that none of these truly ancient fragments can be assigned to a more recent date than 1140, and that some of them may with probability be looked upon as remains of the shell of the first church, erected in the course of the latter half of the tenth century. We shall per-

* “On the 14th day of April, 1374, there were found, in this church of the first martyr St. Stefano, two hundred and more bodies of holy martyrs, by the venerable priest, Matthew Fradello, incumbent of the church.”

† *Notizie Storiche*, p. 620.

haps obtain some further reason for this belief as we examine these remains themselves.

§ XIII. Of the body of the church, unhappily, they are few and obscure ; but the general form and extent of the building, as shown in the plan, Plate I. fig. 2, are determined, first, by the breadth of the uninjured east end DE ; secondly, by some remains of the original brickwork of the clerestory, and in all probability of the side walls also, though these have been refaced ; and finally by the series of nave shafts, which are still perfect. The doors A and B may or may not be in their original positions ; there must of course have been always, as now, a principal entrance at the west end. The ground plan is composed, like that of Torcello, of nave and aisles only, but the clerestory has transepts extending as far as the outer wall of the aisles. The semicircular apse, thrown out in the centre of the east end, is now the chief feature of interest in the church, though the nave shafts and the eastern extremities of the aisles, outside, are also portions of the original building ; the latter having been modernized in the interior, it cannot now be ascertained whether, as is probable, the aisles had once round ends as well as the choir. The spaces FG form small chapels, of which G has a straight terminal wall behind its altar, and F a curved one, marked by the dotted line ; the partitions which divide these chapels from the presbytery are also indicated by dotted lines, being modern work.

§ XIV. The plan is drawn carefully to scale, but the relation in which its proportions are disposed can hardly be appreciated by the eye. The width of the nave from shaft to opposite shaft is 32 feet 8 inches ; of the aisles, from the shaft to the wall, 16 feet 2 inches, or allowing 2 inches for the thickness of the modern wainscot, 16 feet 4 inches, half the breadth of the nave exactly. The intervals between the shafts are exactly one fourth of the width of the nave, or 8 feet 2 inches, and the distance between the great piers which form the pseudo-transept is 24 feet 6 inches, exactly three times the interval of the shafts. So the four distances are accurately in arithmetical proportion ; i.e.

				Ft.	In.
Interval of shafts	.	.	.	8	2
Width of aisle	.	.	.	16	4
Width of transept	.	.	.	24	6
Width of nave	.	.	.	32	8

The shafts average 5 feet 4 inches in circumference, as near the base as they can be got at, being covered with wood; and the broadest sides of the main piers are 4 feet 7 inches wide, their narrowest sides 3 feet 6 inches. The distance *a c* from the outmost angle of these piers to the beginning of the curve of the apse is 25 feet, and from that point the apse is nearly semicircular, but it is so encumbered with renaissance fittings that its form cannot be ascertained with perfect accuracy. It is roofed by a concha, or semi-dome; and the external arrangement of its walls provides for the security of this dome by what is, in fact, a system of buttresses as effective and definite as that of any of the northern churches, although the buttresses are obtained entirely by adaptations of the Roman shaft and arch, the lower story being formed by a thick mass of wall lightened by ordinary semicircular round-headed niches, like those used so extensively afterwards in renaissance architecture, each niche flanked by a pair of shafts standing clear of the wall, and bearing deeply moulded arches thrown over the niche. The wall with its pillars thus forms a series of massy buttresses (as seen in the ground plan), on the top of which is an open gallery, backed by a thinner wall, and roofed by arches whose shafts are set above the pairs of shafts below. On the heads of these arches rests the roof. We have, therefore, externally a heptagonal apse, chiefly of rough and common brick, only with marble shafts and a few marble ornaments; but for that very reason all the more interesting, because it shows us what may be done, and what was done, with materials such as are now at our own command; and because in its proportions, and in the use of the few ornaments it possesses, it displays a delicacy of feeling rendered doubly notable by the roughness of the work in which laws so subtle are observed and with which so thoughtful ornamentation is associated.

§ xv. First, for its proportions: I shall have occasion in Chapter V. to dwell at some length on the peculiar subtlety of the early Venetian perception for ratios of magnitude; the relations of the sides of this heptagonal apse supply one of the first and most curious instances of it. The proportions above given of the nave and aisles might have been dictated by a mere love of mathematical precision; but those of the apse could only have resulted from a true love of harmony.

In fig. 6, Plate I. the plan of this part of the church is given on a large scale, showing that its seven external sides are arranged on a line less than a semicircle, so that if the figure were completed, it would have sixteen sides; and it will be observed also, that the seven sides are arranged in four magnitudes, the widest being the central one. The brickwork is so much worn away, that the measures of the arches are not easily ascertainable, but those of the plinth on which they stand, which is nearly uninjured, may be obtained accurately. This plinth is indicated by the open line in the ground plan, and its sides measure respectively:

					Ft.	In.
1st. <i>ab</i> in plan	6	7
2nd. <i>bc</i>	7	7
3rd. <i>cd</i>	7	5
4th. <i>de</i> (central)	7	10
5th. <i>ef</i>	7	5
. <i>fg</i>	7	8
7th. <i>gh</i>	6	10

§ xvi. Now observe what subtle feeling is indicated by this delicacy of proportion. How fine must the perceptions of grace have been in those builders who could not be content without *some* change between the second and third, the fifth and sixth terms of proportion, such as should oppose the general direction of its cadence, and yet *were* content with a diminution of two inches on a breadth of seven feet and a half! For I do not suppose that the reader will think the curious lessening of the third and fifth arch a matter of accident, and

even if he did so, I shall be able to prove to him hereafter that it was not, but that the early builders were always desirous of obtaining some alternate proportion of this kind. The relations of the numbers are not easily comprehended in the form of feet and inches, but if we reduce the first four of them into inches, and then subtract some constant number, suppose 75, from them all, the remainders 4, 16, 14, 19, will exhibit the ratio of proportion in a clearer, though exaggerated form.

§ XVII. The pairs of circular spots at *b*, *c*, *d*, &c., on the ground plan fig. 6, represent the bearing shafts, which are all of solid marble as well as their capitals. Their measures and various other particulars respecting them are given in Appendix 6. "Apse of Murano;" here I only wish the reader to note the coloring of their capitals. Those of the two single shafts in the angles (*a*, *h*) are both of deep purple marble; the two next pairs, *b* and *g*, are of white marble; the pairs *c* and *f* are of purple, and *d* and *e* are of white: thus alternating with each other on each side; two white meeting in the centre. Now observe, *the purple capitals are all left plain; the white are all sculptured.* For the old builders knew that by carving the purple capitals they would have injured them in two ways: first, they would have mixed a certain quantity of grey shadow with the surface hue, and so adulterated the purity of the color; secondly, they would have drawn away the thoughts from the color, and prevented the mind from fixing upon it or enjoying it, by the degree of attention which the sculpture would have required. So they left their purple capitals full broad masses of color; and sculptured the white ones, which would otherwise have been devoid of interest.

§ XVIII. But the feature which is most to be noted in this apse is a band of ornament, which runs round it like a silver girdle, composed of sharp wedges of marble, precious inlaid, and set like jewels into the brickwork; above it there is another band of triangular recesses in the bricks, of nearly similar shape, and it seems equally strange that all the marbles should have fallen from it, or that it should have been originally destitute of them. The reader may choose his hypothesis; but there is quite enough left to interest us in

the lower band, which is fortunately left in its original state, as is sufficiently proved by the curious niceties in the arrangement of its colors, which are assuredly to be attributed to the care of the first builder. A word or two, in the first place, respecting the means of color at his disposal.

§ XIX. I stated that the building was, for the most part, composed of yellow brick. This yellow is very nearly pure, much more positive and somewhat darker than that of our English light brick, and the material of the brick is very good and hard, looking, in places, almost vitrified, and so compact as to resemble stone. Together with this brick occurs another of a deep full red, and more porous substance, which is used for decoration chiefly, while all the parts requiring strength are composed of the yellow brick. Both these materials are *cast into any shape and size* the builder required, either into curved pieces for the arches, or flat tiles for filling the triangles; and, what is still more curious, the thickness of the yellow bricks used for the walls varies considerably, from two inches to four; and their length also, some of the larger pieces used in important positions being a foot and a half long.

With these two kinds of brick, the builder employed five or six kinds of marble: pure white, and white veined with purple; a brecciated marble of white and black; a brecciated marble of white and deep green; another, deep red, or nearly of the color of Egyptian porphyry; and a grey and black marble, in fine layers.

§ XX. The method of employing these materials will be understood at once by a reference to the opposite plate (Plate III.), which represents two portions of the lower band. I could not succeed in expressing the variation and chequering of color in marble, by real tints in the print; and have been content, therefore, to give them in line engraving. The different triangles are, altogether, of ten kinds:

- a. Pure white marble with sculptured surface (as the third and fifth in the upper series of Plate III.).
- b. Cast triangle of red brick with a sculptured round-headed piece of white marble inlaid (as the first and seventh of the upper series, Plate III.).

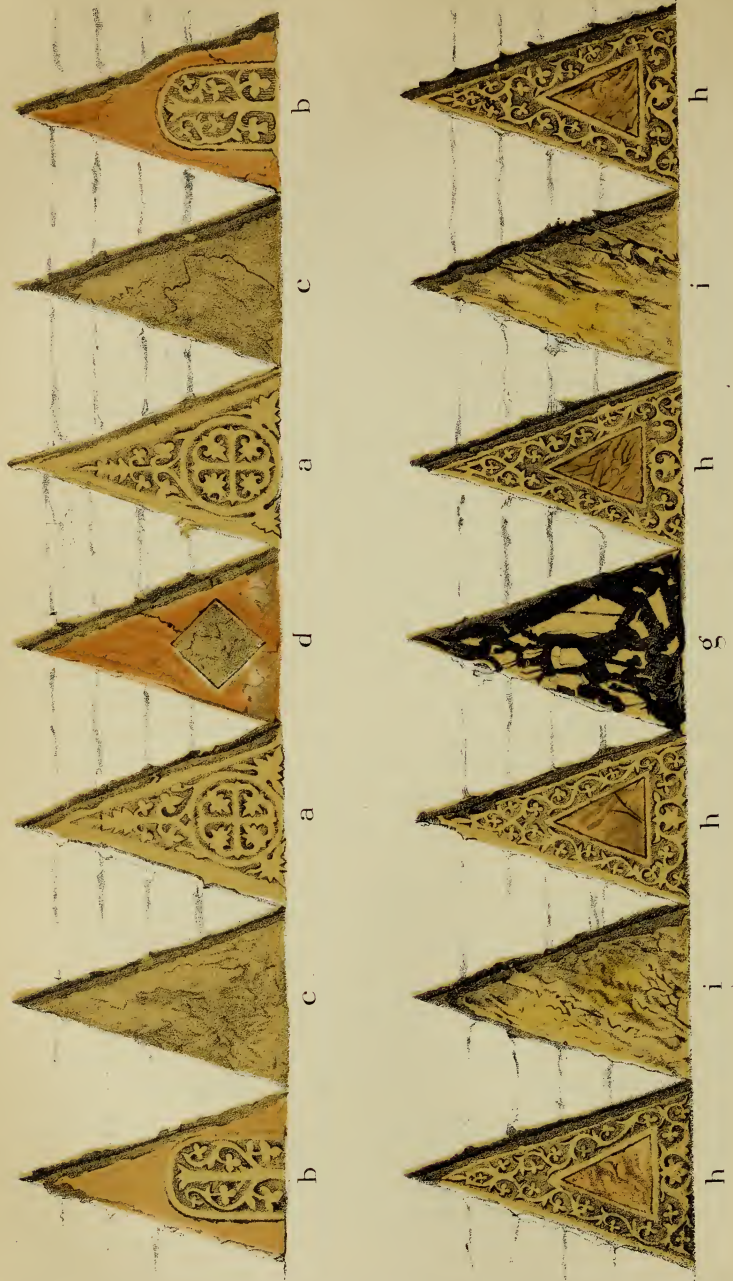

- c. A plain triangle of greenish black marble, now perhaps considerably paler in color than when first employed (as the second and sixth of the upper series of Plate III.).
- d. Cast red brick triangle, with a diamond inlaid of the above-mentioned black marble (as the fourth in the upper series of Plate III.).
- e. Cast white brick, with an inlaid round-headed piece of marble, variegated with black and yellow, or white and violet (not seen in the plate).
- f. Occurs only once, a green-veined marble, forming the upper part of the triangle, with a white piece below.
- g. Occurs only once. A brecciated marble of intense black and pure white, the centre of the lower range in Plate III.
- h. Sculptured white marble with a triangle of veined purple marble inserted (as the first, third, fifth, and seventh of the lower range in Plate III.).
- i. Yellow or white marble veined with purple (as the second and sixth of the lower range in Plate III.).
- k. Pure purple marble, not seen in this plate.

§ XXI. The band, then, composed of these triangles, set close to each other in varied but not irregular relations, is thrown, like a necklace of precious stones, round the apse and along the ends of the aisles; each side of the apse taking, of course, as many triangles as its width permits. If the reader will look back to the measures of the sides of the apse, given before, p. 42, he will see that the first and seventh of the series, being much narrower than the rest, cannot take so many triangles in their band. Accordingly, they have only six each, while the other five sides have seven. Of these groups of seven triangles each, that used for the third and fifth sides of the apse is the uppermost in Plate III.; and that used for the centre of the apse, and of the whole series, is the lowermost in the same plate; *the piece of black and white marble being used to emphasize the centre of the chain*, exactly as a painter would use a dark touch for a similar purpose.

§ XXII. And now, with a little trouble, we can set before the reader, at a glance, the arrangement of the groups along the entire extremity of the church.

There are thirteen recesses, indicative of thirteen arches, seen in the ground plan, fig. 2, Plate I. Of these, the second

and twelfth arches rise higher than the rest ; so high as to break the decorated band ; and the groups of triangles we have to enumerate are, therefore, only eleven in number ; one above each of the eleven low arches. And of these eleven, the first and second, tenth and eleventh, are at the ends of the aisles ; while the third to the ninth, inclusive, go round the apse. Thus, in the following table, the numerals indicate the place of each entire group (counting from the south to the north side of the church, or from left to right), and the letters indicate the species of triangle of which it is composed, as described in the list given above.

	6. h. i. h. g. h. i. h.	
5. b. c. a. d. a. c. b.		7. b. c. a. d. a. c. b.
4. b. a. b. c. a. e. a.		8. a. e. a. c. b. a. b.
3. b. a. b. e. b. a.		9. a. b. e. b. a. b.
2. a. b. c.		10. a. b. c. b.
1. a. b. c. b. a.		11. b. a. c. a. f. a. a.

The central group is put first, that it may be seen how the series on the two sides of the apse answer each other. It was a very curious freak to insert the triangle e, in the outermost place *but one* of both the fourth and eighth sides of the apse, and in the outermost *but two* in the third and ninth ; in neither case having any balance to it in its own group, and the real balance being only effected on the other side of the apse, which it is impossible that any one should see at the same time. This is one of the curious pieces of system which so often occur in mediæval work, of which the key is now lost. The groups at the ends of the transepts correspond neither in number nor arrangement ; we shall presently see why, but must first examine more closely the treatment of the triangles themselves, and the nature of the floral sculpture employed upon them.

§ XIII. As the scale of Plate III. is necessarily small, I have given three of the sculptured triangles on a larger scale in Plate IV. opposite. Fig. 3 is one of the four in the lower series of Plate IV., and figs. 4 and 5 from another group.

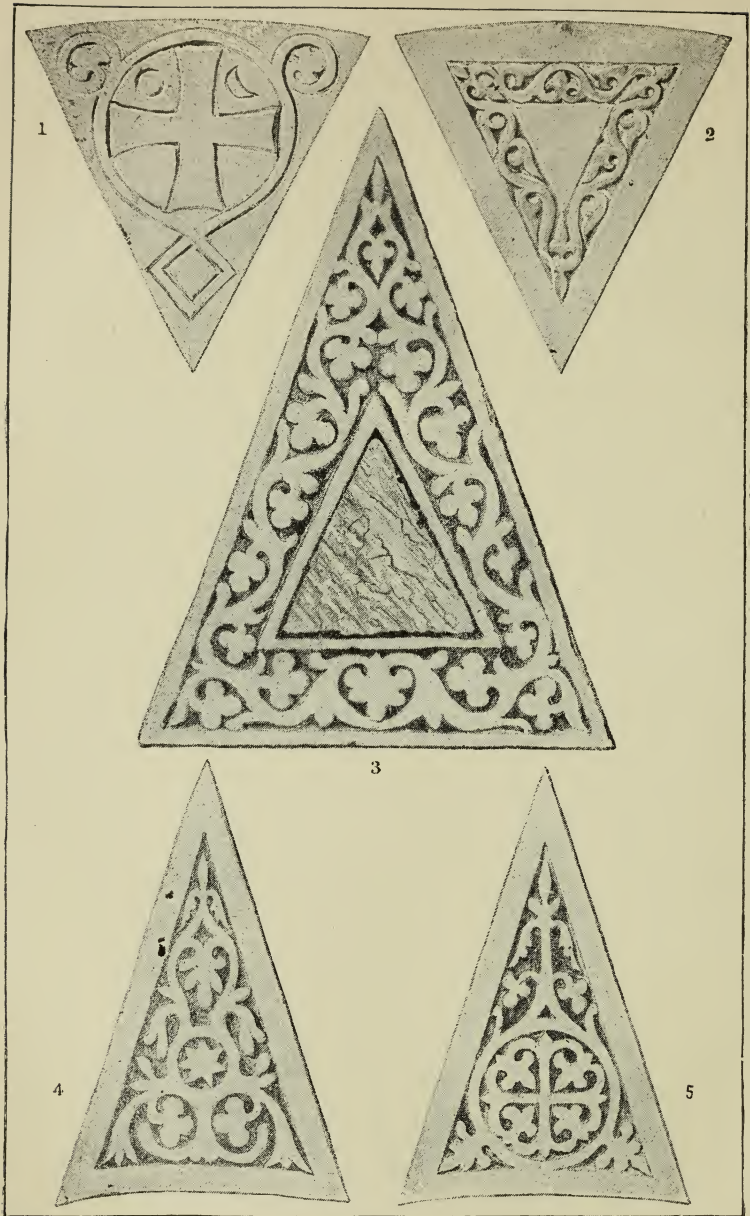

PLATE IV.—SCULPTURES OF MURANO.

The forms of the trefoils are here seen more clearly ; they, and all the other portions of the design, are thrown out in low and flat relief, the intermediate spaces being cut out to the depth of about a quarter of an inch. I believe these vacant spaces were originally filled with a black composition, which is used in similar sculptures at St. Mark's, and of which I found some remains in an archivolt moulding here, though not in the triangles. The surface of the whole would then be perfectly smooth, and the ornamental form relieved by a ground of dark grey ; but, even though this ground is lost, the simplicity of the method insures the visibility of all its parts at the necessary distance (17 or 18 feet), and the quaint trefoils have a crispness and freshness of effect which I found it almost impossible to render in a drawing. Nor let us fail to note in passing how strangely delightful to the human mind the trefoil always is. We have it here repeated five or six hundred times in the space of a few yards, and yet are never weary of it. In fact, there are two mystical feelings at the root of our enjoyment of this decoration : the one is the love of trinity in unity, the other that of the sense of fulness with order ; of every place being instantly filled, and yet filled with propriety and ease ; the leaves do not push each other, nor put themselves out of their own way, and yet whenever there is a vacant space, a leaf is always ready to step in and occupy it.

§ xxiv. I said the trefoil was five or six hundred times repeated. It is so, but observe, it is hardly ever twice of the same size ; and this law is studiously and resolutely observed. In the carvings *a* and *b* of the upper series, Plate III., the diminution of the leaves might indeed seem merely representative of the growth of the plant. But look at the lower : the triangles of inlaid purple marble are made much more nearly equilateral than those of white marble, into whose centres they are set, so that the leaves may continually diminish in size as the ornament descends at the sides. The reader may perhaps doubt the accuracy of the drawing on the smaller scale, but in that given larger, fig. 3, Plate IV., the angles are all measured, and the *purposeful* variation of width in the border therefore

admits of no dispute.* Remember how absolutely this principle is that of nature; the same leaf continually repeated, but never twice of the same size. Look at the clover under your feet, and then you will see what this Murano builder meant, and that he was not altogether a barbarian.

§ xxv. Another point I wish the reader to observe is, the importance attached to *color* in the mind of the designer. Note especially—for it is of the highest importance to see how the great principles of art are carried out through the whole building—that, as only the white capitals are sculptured below, only the white triangles are sculptured above. No colored triangle is touched with sculpture; note also, that in the two principal groups of the apse, given in Plate III., the centre of the group is color, not sculpture, and the eye is evidently intended to be drawn as much to the chequers of the stone, as to the intricacies of the chiselling. It will be noticed also how much more precious the lower series, which is central in the apse, is rendered, than the one above it in the plate, which flanks it: there is no brick in the lower one, and three kinds of variegated marble are used in it, whereas the upper is composed of brick, with black and white marble only; and lastly—for this is especially delightful—see how the workman made his chiselling finer where it was to go with the variegated marbles, and used a bolder pattern with the coarser brick and dark stone. The subtlety and perfection of artistical feeling in all this are so redundant, that in the building itself the eye can rest upon this colored chain with the same kind of delight that it has in a piece of the embroidery of Paul Veronese.

§ xxvi. Such being the construction of the lower band, that of the upper is remarkable only for the curious change in its proportions. The two are separated, as seen in the little woodcut on the opposite page, by a string-course composed of two layers of red bricks, of which the uppermost projects as a cornice, and is sustained by an intermediate course of irregu-

* The intention is farther confirmed by the singular variation in the breadth of the small fillet which encompasses the inner marble. It is much narrower at the bottom than at the sides, so as to recover the original breadth in the lower border.

lar brackets, obtained by setting the thick yellow bricks edge-ways, in the manner common to this day. But the wall above is carried up perpendicularly from this projection, so that the whole upper band is advanced to the thickness of a brick over the lower one. The result of this is, of course, that each side of the apse is four or five inches broader above than below ; so that the same number of triangles which filled a whole side of the lower band, leave an inch or two blank at each angle in the upper. This would have looked awkward, if there had been the least appearance of its being an accidental

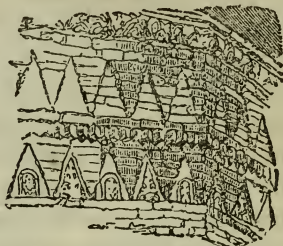

FIG. II.

error ; so that, in order to draw the eye to it, and show that it is done on purpose, the upper triangles are made about two inches higher than the lower ones, so as to be much more acute in proportion and effect, and actually to look considerably narrower, though of the same width at the base. By this means they are made lighter in effect, and subordinated to the richly decorated series of the lower band, and the two courses, instead of repeating, unite with each other, and become a harmonious whole.

In order, however, to make still more sure that this difference in the height of the triangles should not escape the eye, another course of plain bricks is added above their points, increasing the width of the band by another two inches. There are five courses of bricks in the lower band, and it measures 1 ft. 6 in. in height : there are seven courses in the upper (of which six fall between the triangles), and it measures 1 ft. 10 in. in height, except at the extremity of the northern aisle, where for some mysterious reason the intermediate cornice is sloped upwards so as to reduce the upper triangles to the same height as those below. And here, finally, observe how determined the builder was that the one series should not be a mere imitation of the other ; he could not now make them acute by additional height—so he here, and here only, *narrowed their bases*, and we have seven of them above, to six below.

§ xxvii. We come now to the most interesting portion of the whole east end, the archivolt at the end of the northern aisle.

It was above stated, that the band of triangles was broken by two higher arches at the ends of the aisles. That, however, on the northern side of the apse does not entirely interrupt, but lifts it, and thus forms a beautiful and curious archivolt, drawn opposite, in Plate V. The upper band of triangles cannot rise together with the lower, as it would otherwise break the cornice prepared to receive the second story; and the curious zigzag with which its triangles die away against the sides of the arch, exactly as waves break upon the sand, is one of the most curious features in the structure.

It will be also seen that there is a new feature in the treatment of the band itself when it turns the arch. Instead of leaving the bricks projecting between the sculptured or colored stones, reversed triangles of marble are used, inlaid to an equal depth with the others in the brickwork, but projecting beyond them so as to produce a sharp dark line of zigzag at their junctions. Three of these supplementary stones have unhappily fallen out, so that it is now impossible to determine the full harmony of color in which they were originally arranged. The central one, corresponding to the keystone in a common arch, is, however, most fortunately left, with two lateral ones on the right hand, and one on the left.

§ xxviii. The keystone, if it may be so called, is of white marble, the lateral voussoirs of purple; and these are the only colored stones in the whole building which are sculptured; but they are sculptured in a way which more satisfactorily proves that the principle above stated was understood by the builders, than if they had been left blank. The object, observe, was to make the archivolt as rich as possible; eight of the white sculptured marbles were used upon it in juxtaposition. Had the purple marbles been left altogether plain, they would have been out of harmony with the elaboration of the rest. It became necessary to touch them with sculpture as a mere sign of carefulness and finish, but at the same time destroying their colored surface as little as possible. *The orna-*



J. Rusconi.

J. C. Armytage.

Archivolt in the Duomo of Murano.

S. S. NA. UYS. PEGATV. R. M. H. C. U. S. T.

ment is merely outlined upon them with a fine incision, as if it had been etched out on their surface preparatory to being carved. In two of them it is composed merely of three concentric lines, parallel with the sides of the triangle; in the third, it is a wreath of beautiful design, which I have drawn of larger size in fig. 2, Plate V., that the reader may see how completely the surface is left undestroyed by the delicate incisions of the chisel, and may compare the method of working with that employed on the white stones, two of which are given in that plate, figs. 4 and 5. The keystone, of which we have not yet spoken, is the only white stone worked with the light incision; its design not being capable of the kind of workmanship given to the floral ornaments, and requiring either to be carved in complete relief, or left as we see it. It is given at fig. 1 of Plate IV. The sun and moon on each side of the cross are, as we shall see in the fifth Chapter, constantly employed in the keystones of Byzantine arches.

§ XXIX. We must not pass without notice the grey and green pieces of marble inserted at the flanks of the arch. For, observe, there was a difficulty in getting the forms of the triangle into anything like reconciliation at this point, and a mediæval artist always delights in a difficulty: instead of concealing it, he boasts of it; and just as we saw above that he directed the eye to the difficulty of filling the expanded sides of the upper band by elongating his triangles, so here, having to put in a piece of stone of awkward shape, he makes that very stone the most conspicuous in the whole arch, on both sides, by using in one case a dark, cold grey; in the other a vigorous green, opposed to the warm red and purple and white of the stones above and beside it. The green and white piece on the right is of a marble, as far as I know, exceedingly rare. I at first thought the white fragments were inlaid, so sharply are they defined upon their ground. They are indeed inlaid, but I believe it is by nature; and that the stone is a calcareous breccia of great mineralogical interest. The white spots are of singular value in giving piquancy to the whole range of more delicate transitional hues above. The effect of the whole is, however, generally injured by the loss of the

three large triangles above. I have no doubt they were purple, like those which remain, and that the whole arch was thus one zone of white, relieved on a purple ground, encircled by the scarlet cornices of brick, and the whole chord of color contrasted by the two precious fragments of grey and green at either side.

§ xxx. The two pieces of carved stone inserted at each side of the arch, as seen at the bottom of Plate V., are of different workmanship from the rest ; they do not match each other, and form part of the evidence which proves that portions of the church had been brought from the mainland. One bears an inscription, which, as its antiquity is confirmed by the shapelessness of its letters, I was much gratified by not being able to read ; but M. Lazari, the intelligent author of the latest and best Venetian guide, with better skill, has given as much of it as remains, thus :

SCEMARIEDIGENETRICISETBEATIESTEFANIMART
 IRIEGOINDICNVSETPECCATVRDOMENICVST

I have printed the letters as they are placed in the inscription, in order that the reader may form some idea of the difficulty of reading such legends when the letters, thus thrown into one heap, are themselves of strange forms, and half worn away ; any gaps which at all occur between them coming in the wrong places. There is no doubt, however, as to the reading of this fragment :—“ T . . . Sancte Marie Domini Genetricis et beati Estefani martiri ego indignus et peccator Domenicus T.” On these two initial and final T’s, expanding one into Templum, the other into Torcellanus, M. Lazari finds an ingenious conjecture that the inscription records the elevation of the church under a certain bishop Dominic of Torcello (named in the Altinat Chronicle), who flourished in the middle of the ninth century. If this were so, as the inscription occurs broken off on a fragment inserted scornfully in the present edifice, this edifice must be of the twelfth century, worked with fragments taken from the ruins of that built in the ninth. The two T’s are, however, hardly a foundation large enough to build the church upon, a hundred

years before the date assigned to it both by history and tradition (see above, § VIII.) : and the reader has yet to be made aware of the principal fact bearing on the question.

§ XXXI. Above the first story of the apse runs, as he knows already, a gallery under open arches, protected by a light balustrade. This balustrade is worked on the *outside* with mouldings, of which I shall only say at present that they are of exactly the same school as the greater part of the work of the existing church. But the great horizontal pieces of stone which form the top of this balustrade are fragments of an older building turned inside out. They are covered with sculptures on the back, only to be seen by mounting into the gallery. They have once had an arcade of low wide arches traced on their surface, the spandrils filled with leafage, and archivolts enriched with studded chainwork and with crosses in their centres. These pieces have been used as waste marble by the architect of the existing apse. The small arches of the present balustrade are cut mercilessly through the old work, and the profile of the balustrade is cut out of what was once the back of the stone ; only some respect is shown for the crosses in the old design, the blocks are cut so that these shall be not only left uninjured, but come in the centre of the balustrades.

§ XXXII. Now let the reader observe carefully that this balustrade of Murano is a fence of other things than the low gallery round the deserted apse. It is a barrier between two great schools of early architecture. On one side it was cut by Romanesque workmen of the early Christian ages, and furnishes us with a distinct type of a kind of ornament which, as we meet with other examples of it, we shall be able to describe in generic terms, and to throw back behind this balustrade, out of our way. The *front* of the balustrade presents us with a totally different condition of design, less rich, more graceful, and here shown in its simplest possible form. From the outside of this bar of marble we shall commence our progress in the study of existing Venetian architecture. The only question is, do we begin from the tenth or from the twelfth century?

§ xxxiii. I was in great hopes once of being able to determine this positively ; but the alterations in all the early buildings of Venice are so numerous, and the foreign fragments introduced so innumerable, that I was obliged to leave the question doubtful. But one circumstance must be noted, bearing upon it closely.

In the woodcut below, Fig. III., *b* is an archivolt of Murano, *a* one of St. Mark's ; the latter acknowledged by all historians and all investigators to be of the twelfth century.

All the twelfth century archivolts in Venice, without exception, are on the model of *a*, differing only in their decora-

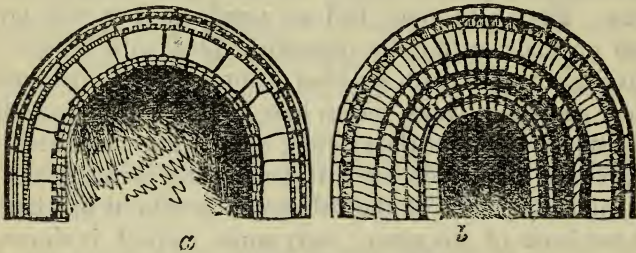

FIG. III.

tions and sculpture. There is not one which resembles that of Murano.

But the deep mouldings of Murano are almost exactly similar to those of St. Michele of Pavia, and other Lombard churches built, some as early as the seventh, others in the eighth, ninth, and tenth centuries.

On this ground it seems to me probable that the existing apse of Murano is part of the original earliest church, and that the inscribed fragments used in it have been brought from the mainland. The balustrade, however, may still be later than the rest ; it will be examined, hereafter, more carefully.*

I have not space to give any farther account of the exterior of the building, though one half of what is remarkable in it remains untold. We must now see what is left of interest within the walls.

* Its elevation is given to scale in fig. 4, Plate XIII., below.

§ xxxiv. All hope is taken away by our first glance ; for it falls on a range of shafts whose bases are concealed by wooden panelling, and which sustain arches decorated in the most approved style of Renaissance upholstery, with stucco roses in squares under the soffits, and egg and arrow mouldings on the architraves, gilded, on a ground of spotty black and green, with a small pink-faced and black-eyed cherub on every keystone ; the rest of the church being for the most part concealed either by dirty hangings, or dirtier whitewash, or dim pictures on warped and wasting canvas ; all vulgar, vain, and foul. Yet let us not turn back, for in the shadow of the apse our more careful glance shows us a Greek Madonna, pictured on a field of gold ; and we feel giddy at the first step we make on the pavement, for it, also, is of Greek mosaic waved like the sea, and dyed like a dove's neck.

§ xxxv. Nor are the original features of the rest of the edifice altogether indecipherable ; the entire series of shafts marked in the ground plan on each side of the nave, from the western entrance to the apse, are nearly uninjured ; and I believe the stilted arches they sustain are those of the original fabric, though the masonry is covered by the Renaissance stucco mouldings. Their capitals, for a wonder, are left bare, and appear to have sustained no farther injury than has resulted from the insertion of a large brass chandelier into each of their abaci, each chandelier carrying a sublime wax candle two inches thick, fastened with wire to the wall above. The due arrangement of these appendages, previous to festal days, can only be effected from a ladder set against the angle of the abacus ; and ten minutes before I wrote this sentence, I had the privilege of watching the candlelighter at his work, knocking his ladder about the heads of the capitals as if they had given him personal offence. He at last succeeded in breaking away one of the lamps altogether, with a bit of the marble of the abacus ; the whole falling in ruin to the pavement, and causing much consultation and clamor among a tribe of beggars who were assisting the sacristan with their wisdom respecting the festal arrangements.

§ xxxvi. It is fortunate that the capitals themselves, being

somewhat rudely cut, can bear this kind of treatment better than most of those in Venice. They are all founded on the Corinthian type, but the leaves are in every one different: those of the easternmost capital of the southern range are the best, and very beautiful, but presenting no feature of much interest, their workmanship being inferior to most of the imitations of Corinthian common at the period; much more to the rich fantasies which we have seen at Torcello. The apse itself, to-day (12th September, 1851), is not to be described; for just in front of it, behind the altar, is a magnificent curtain of new red velvet with a gilt edge and two golden tassels, held up in a dainty manner by two angels in the upholsterer's service; and above all, for concentration of effect, a star or sun, some five feet broad, the spikes of which conceal the whole of the figure of the Madonna except the head and hands.

§ xxxvii. The pavement is however still left open, and it is of infinite interest, although grievously distorted and defaced. For whenever a new chapel has been built, or a new altar erected, the pavement has been broken up and readjusted so as to surround the newly inserted steps or stones with some appearance of symmetry; portions of it either covered or carried away, others mercilessly shattered or replaced by modern imitations, and those of very different periods, with pieces of the old floor left here and there in the midst of them, and worked round so as to deceive the eye into acceptance of the whole as ancient. The portion, however, which occupies the western extremity of the nave, and the parts immediately adjoining it in the aisles, are, I believe, in their original positions, and very little injured: they are composed chiefly of groups of peacocks, lions, stags, and griffins,—two of each in a group, drinking out of the same vase, or shaking claws together,—enclosed by interlacing bands, and alternating with chequer or star patterns, and here and there an attempt at representation of architecture, all worked in marble mosaic. The floors of Torcello and of St. Mark's are executed in the same manner; but what remains at Murano is finer than either, in the extraordinary play of color obtained by the

use of variegated marbles. At St. Mark's the patterns are more intricate, and the pieces far more skilfully set together ; but each piece is there commonly of one color : at Murano every fragment is itself variegated, and all are arranged with a skill and feeling not to be taught, and to be observed with deep reverence, for that pavement is not dateless, like the rest of the church ; it bears its date on one of its central circles, 1140, and is, in my mind, one of the most precious monuments in Italy, showing thus early, and in those rude chequers which the bared knee of the Murano fisher wears in its daily bending, the beginning of that mighty spirit of Venetian color, which was to be consummated in Titian.

§ xxxviii. But we must quit the church for the present, for its garnishings are completed ; the candles are all upright in their sockets, and the curtains drawn into festoons, and a pasteboard crescent, gay with artificial flowers, has been attached to the capital of every pillar, in order, together with the gilt angels, to make the place look as much like Paradise as possible. If we return to-morrow, we shall find it filled with woful groups of aged men and women, wasted and fever-struck, fixed in paralytic supplication, half-kneeling, half-couched upon the pavement ; bowed down, partly in feebleness, partly in a fearful devotion, with their grey clothes cast far over their faces, ghastly and settled into a gloomy animal misery, all but the glittering eyes and muttering lips.

Fit inhabitants, these, for what was once the Garden of Venice, “a terrestrial paradise,—a place of nymphs and demi-gods !” *

§ xxxix. We return, yet once again, on the following day. Worshippers and objects of worship, the sickly crowd and gilded angels, all are gone ; and there, far in the apse, is seen the sad Madonna standing in her folded robe, lifting her hands in vanity of blessing. There is little else to draw away our thoughts from the solitary image. An old wooden tablet, carved into a rude effigy of San Donato, which occupies the central niche in the lower part of the tribune, has an interest

* “Luogo de' ninfe e de' semidei.”—*M. Andrea Calmo*, quoted by Multinelli, *Annali Urbani di Venezia* (Venice, 1841), p. 362.

of its own, but is unconnected with the history of the older church. The faded frescoes of saints, which cover the upper tier of the wall of the apse, are also of comparatively recent date, much more the piece of Renaissance workmanship, shaft and entablature, above the altar, which has been thrust into the midst of all, and has cut away part of the feet of the Madonna. Nothing remains of the original structure but the semidome itself, the cornice whence it springs, which is the same as that used on the exterior of the church, and the border and face-arch which surround it. The ground of the dome is of gold, unbroken except by the upright Madonna, and usual inscription, M̃R @V. The figure wears a robe of blue, deeply fringed with gold, which seems to be gathered on the head and thrown back on the shoulders, crossing the breast, and falling in many folds to the ground. The under robe, shown beneath it where it opens at the breast, is of the same color; the whole, except the deep gold fringe, being simply the dress of the women of the time. "Le donne, anco elle del 1100, vestivano *di turchino con manti in spalla*, che le coprivano dinanzi e di dietro." *

Round the dome there is a colored mosaic border; and on the edge of its arch, legible by the whole congregation, this inscription :

"QUOS EVA CONTRIVIT, PIA VIRGO MARIA REDEMIT;
HANC CUNCTI LAUDENT, QUI CRISTI MUNERE GAUDENT." †

The whole edifice is, therefore, simply a temple to the Virgin: to her is ascribed the fact of Redemption, and to her its praise.

§ XL. "And is this," it will be asked of me, "the time, is

* "The women, even as far back as 1100, wore dresses of blue, with mantles on the shoulder, which clothed them before and behind."—*San-sovino*.

It would be difficult to imagine a dress more modest and beautiful. See Appendix 7.

† "Whom Eve destroyed, the pious Virgin Mary redeemed;
All praise her, who rejoice in the Grace of Christ."

Vide Appendix 8.

this the worship, to which you would have us look back with reverence and regret?" Inasmuch as redemption is ascribed to the Virgin, No. Inasmuch as redemption is a thing desired, believed, rejoiced in, Yes,—and Yes a thousand times. As far as the Virgin is worshipped in place of God, No; but as far as there is the evidence of worship itself, and of the sense of a Divine presence, Yes. For there is a wider division of men than that into Christian and Pagan: before we ask what a man worships, we have to ask whether he worships at all. Observe Christ's own words on this head: "God is a spirit; and they that worship Him must worship Him in spirit, *and in truth.*" The worshipping in spirit comes first, and it does not necessarily imply the worshipping in truth. Therefore, there is first the broad division of men into Spirit worshippers and Flesh worshippers; and then, of the Spirit worshippers, the farther division into Christian and Pagan,—worshippers in Falsehood or in Truth. I therefore, for the moment, omit all inquiry how far the Mariolatry of the early church did indeed eclipse Christ, or what measure of deeper reverence for the Son of God was still felt through all the grosser forms of Madonna worship. Let that worship be taken at its worst; let the goddess of this dome of Murano be looked upon as just in the same sense an idol as the Athene of the Acropolis, or the Syrian Queen of Heaven; and then, on this darkest assumption, balance well the difference between those who worship and those who worship not;—that difference which there is in the sight of God, in all ages, between the calculating, smiling, self-sustained, self-governed man, and the believing, weeping, wondering, struggling, Heaven-governed man;—between the men who say in their hearts "there is no God," and those who acknowledge a God at every step, "if haply they might feel after Him and find Him." For that is indeed the difference which we shall find, in the end, between the builders of this day and the builders on that sand island long ago. They *did* honor something out of themselves; they did believe in spiritual presence judging, animating, redeeming them; they built to its honor and for its habitation; and were content to pass away in nameless

multitudes, so only that the labor of their hands might fix in the sea-wilderness a throne for their guardian angel. In this was their strength, and there was indeed a Spirit walking with them on the waters, though they could not discern the form thereof, though the Master's voice came not to them, "It is I." What their error cost them, we shall see hereafter; for it remained when the majesty and the sincerity of their worship had departed, and remains to this day. Mariolatry is no special characteristic of the twelfth century; on the outside of that very tribune of San Donato, in its central recess, is an image of the Virgin which receives the reverence once paid to the blue vision upon the inner dome. With rouged cheeks and painted brows, the frightful doll stands in wretchedness of rags, blackened with the smoke of the votive lamps at its feet; and if we would know what has been lost or gained by Italy in the six hundred years that have worn the marbles of Murano, let us consider how far the priests who set up this to worship, the populace who have this to adore, may be nobler than the men who conceived that lonely figure standing on the golden field, or than those to whom it seemed to receive their prayer at evening, far away, where they only saw the blue clouds rising out of the burning sea.

CHAPTER IV.

ST. MARK'S.

§ I. "AND so Barnabas took Mark, and sailed unto Cyprus." It as the shores of Asia lessened upon his sight, the spirit of prophecy had entered into the heart of the weak disciple who had turned back when his hand was on the plough, and who had been judged, by the chiefest of Christ's captains, unworthy thenceforward to go forth with him to the work,* how wonderful would he have thought it, that by the lion symbol in future ages he was to be represented among men! how

* Acts, xiii. 13; xv. 38, 39.

woful, that the war-cry of his name should so often reanimate the rage of the soldier, on those very plains where he himself had failed in the courage of the Christian, and so often dye with fruitless blood that very Cypriot Sea, over whose waves, in repentance and shame, he was following the Son of Consolation !

§ II. That the Venetians possessed themselves of his body in the ninth century, there appears no sufficient reason to doubt, nor that it was principally in consequence of their having done so, that they chose him for their patron saint. There exists, however, a tradition that before he went into Egypt he had founded the Church at Aquileia, and was thus, in some sort, the first bishop of the Venetian isles and people. I believe that this tradition stands on nearly as good grounds as that of St. Peter having been the first bishop of Rome ;* but as usual, it is enriched by various later additions and embellishments, much resembling the stories told respecting the church of Murano. Thus we find it recorded by the Santo Padre who compiled the “*Vite de' Santi spettanti alle Chiese di Venezia,*” † that “*St. Mark having seen the people of Aquileia well grounded in religion, and being called to Rome by St. Peter, before setting off took with him the holy bishop Hermagoras, and went in a small boat to the marshes of Venice. There were at that period some houses built upon a certain high bank called Rialto, and the boat being driven by the wind was anchored in a marshy place, when St. Mark, snatched into ecstasy, heard the voice of an angel saying to him : ‘Peace be to thee, Mark ; here shall thy body rest.’”* The angel goes on to foretell the building of “*una stupenda, ne più veduta Città ;*” but the fable is hardly ingenious enough to deserve farther relation.

§ III. But whether St. Mark was first bishop of Aquileia or not, St. Theodore was the first patron of the city ; nor can he yet be considered as having entirely abdicated his early right,

* The reader who desires to investigate it may consult Gallicioli, “*Delle Memorie Venete*” (Venice, 1795), tom. ii. p. 332, and the authorities quoted by him.

† Venice, 1761, tom. i. p. 126.

as his statue, standing on a crocodile, still companions the winged lion on the opposing pillar of the piazzetta. A church erected to this Saint is said to have occupied, before the ninth century, the site of St. Mark's; and the traveller, dazzled by the brilliancy of the great square, ought not to leave it without endeavoring to imagine its aspect in that early time, when it was a green field cloister-like and quiet, * divided by a small canal, with a line of trees on each side; and extending between the two churches of St. Theodore and St. Geminian, as the little piazza of Torcello lies between its "palazzo" and cathedral.

§ iv. But in the year 813, when the seat of government was finally removed to the Rialto, a Ducal Palace, built on the spot where the present one stands, with a Ducal Chapel beside it, † gave a very different character to the Square of St. Mark; and fifteen years later, the acquisition of the body of the Saint, and its deposition in the Ducal Chapel, perhaps not yet completed, occasioned the investiture of that chapel with all possible splendor. St. Theodore was deposed from his patronship, and his church destroyed, to make room for the aggrandizement of the one attached to the Ducal Palace, and thenceforward known as "St. Mark's." ‡

§ v. This first church was however destroyed by fire, when the Ducal Palace was burned in the revolt against Candiano, in 976. It was partly rebuilt by his successor, Pietro Orseolo, on a larger scale; and, with the assistance of Byzantine architects, the fabric was carried on under successive Doges for nearly a hundred years; the main building being completed in 1071, but its incrustation with marble not till considerably later. It was consecrated on the 8th of October, 1085, § according to Sansovino and the author of the "Chiesa

* St. Mark's Place, "partly covered by turf, and planted with a few trees; and on account of its pleasant aspect called Broilto or Broglio, that is to say, Garden." The canal passed through it, over which is built the bridge of the Malpassi. Gallicioli, lib. i. cap. viii.

† My authorities for this statement are given below, in the chapter on the Ducal Palace.

‡ In the Chronicles, "Sancti Marci Ducalis Cappella."

§ "To God the Lord, the glorious Virgin Annunciate, and the Protec

Ducale di S. Marco," in 1094 according to Lazari, but certainly between 1084 and 1096, those years being the limits of the reign of Vital Falier; I incline to the supposition that it was soon after his accession to the throne in 1085, though Sansovino writes, by mistake, Ordelafo instead of Vital Falier. But, at all events, before the close of the eleventh century the great consecration of the church took place. It was again injured by fire in 1106, but repaired; and from that time to the fall of Venice there was probably no Doge who did not in some slight degree embellish or alter the fabric, so that few parts of it can be pronounced boldly to be of any given date. Two periods of interference are, however, notable above the rest: the first, that in which the Gothic school had superseded the Byzantine towards the close of the fourteenth century, when the pinnacles, upper archivolt, and window traceries were added to the exterior, and the great screen, with various chapels and tabernacle-work, to the interior; the second, when the Renaissance school superseded the Gothic, and the pupils of Titian and Tintoret substituted, over one half of the church, their own compositions for the Greek mosaics with which it was originally decorated;* happily, though with no good will, having left enough to enable us to imagine and lament what they destroyed. Of this irreparable loss we shall have more to say hereafter; meantime, I wish only to fix in the reader's mind the succession of periods of alteration as firmly and simply as possible.

§ VI. We have seen that the main body of the church may be broadly stated to be of the eleventh century, the Gothic additions of the fourteenth, and the restored mosaics of the

tor St. Mark."—*Corner*, p. 14. It is needless to trouble the reader with the various authorities for the above statements: I have consulted the best. The previous inscription once existing on the church itself:

“Anno milleno transacto bisque trigeno
Desuper undecimo fuit facta primo,”

is no longer to be seen, and is conjectured by *Corner*, with much probability, to have perished “in qualche ristaurò.”

* Signed Bartolomeus Bozza, 1634, 1647, 1656, &c.

seventeenth. There is no difficulty in distinguishing at a glance the Gothic portions from the Byzantine ; but there is considerable difficulty in ascertaining how long, during the course of the twelfth and thirteenth centuries, additions were made to the Byzantine church, which cannot be easily distinguished from the work of the eleventh century, being purposely executed in the same manner. Two of the most important pieces of evidence on this point are, a mosaic in the south transept, and another over the northern door of the façade ; the first representing the interior, the second the exterior, of the ancient church.

§ VII. It has just been stated that the existing building was consecrated by the Doge Vital Falier. A peculiar solemnity was given to that act of consecration, in the minds of the Venetian people, by what appears to have been one of the best arranged and most successful impostures ever attempted by the clergy of the Romish church. The body of St. Mark had, without doubt, perished in the conflagration of 976 ; but the revenues of the church depended too much upon the devotion excited by these relics to permit the confession of their loss. The following is the account given by Corner, and believed to this day by the Venetians, of the pretended miracle by which it was concealed.

“After the repairs undertaken by the Doge Orseolo, the place in which the body of the holy Evangelist rested had been altogether forgotten ; so that the Doge Vital Falier was entirely ignorant of the place of the venerable deposit. This was no light affliction, not only to the pious Doge, but to all the citizens and people ; so that at last, moved by confidence in the Divine mercy, they determined to implore, with prayer and fasting, the manifestation of so great a treasure, which did not now depend upon any human effort. A general fast being therefore proclaimed, and a solemn procession appointed for the 25th day of June, while the people assembled in the church interceded with God in fervent prayers for the desired boon, they beheld, with as much amazement as joy, a slight shaking in the marbles of a pillar (near the place where the altar of the Cross is now), which, presently falling to the

earth, exposed to the view of the rejoicing people the chest of bronze in which the body of the Evangelist was laid."

§ VIII. Of the main facts of this tale there is no doubt. They were embellished afterwards, as usual, by many fanciful traditions; as, for instance, that, when the sarcophagus was discovered, St. Mark extended his hand out of it, with a gold ring on one of the fingers, which he permitted a noble of the Dolfin family to remove; and a quaint and delightful story was further invented of this ring, which I shall not repeat here, as it is now as well known as any tale of the Arabian Nights. But the fast and the discovery of the coffin, by whatever means effected, are facts; and they are recorded in one of the best-preserved mosaics of the north transept, executed very certainly not long after the event had taken place, closely resembling in its treatment that of the Bayeux tapestry, and showing, in a conventional manner, the interior of the church, as it then was, filled by the people, first in prayer, then in thanksgiving, the pillar standing open before them, and the Doge, in the midst of them, distinguished by his crimson bonnet embroidered with gold, but more unmistakably by the inscription "Dux" over his head, as uniformly is the case in the Bayeux tapestry, and most other pictorial works of the period. The church is, of course, rudely represented, and the two upper stories of it reduced to a small scale in order to form a background to the figures; one of those bold pieces of picture history which we in our pride of perspective, and a thousand things besides, never dare attempt. We should have put in a column or two of the real or perspective size, and subdued it into a vague background: the old workman crushed the church together that he might get it all in, up to the cupolas; and has, therefore, left us some useful notes of its ancient form, though any one who is familiar with the method of drawing employed at the period will not push the evidence too far. The two pulpits are there, however, as they are at this day, and the fringe of mosaic flowerwork which then encompassed the whole church, but which modern restorers have destroyed, all but one fragment still left in the south aisle. There is no attempt to represent the other

mosaics on the roof, the scale being too small to admit of their being represented with any success ; but some at least of those mosaics had been executed at that period, and their absence in the representation of the entire church is especially to be observed, in order to show that we must not trust to any negative evidence in such works. M. Lazari has rashly concluded that the central archivolt of St. Mark's *must* be posterior to the year 1205, because it does not appear in the representation of the exterior of the church over the northern door ;* but he justly observes that this mosaic (which is the other piece of evidence we possess respecting the ancient form of the building) cannot itself be earlier than 1205, since it represents the bronze horses which were brought from Constantinople in that year. And this one fact renders it very difficult to speak with confidence respecting the date of any part of the exterior of St. Mark's ; for we have above seen that it was consecrated in the eleventh century, and yet here is one of its most important exterior decorations assuredly retouched, if not entirely added, in the thirteenth, although its style would have led us to suppose it had been an original part of the fabric. However, for all our purposes, it will be enough for the reader to remember that the earliest parts of the building belong to the eleventh, twelfth, and first part of the thirteenth century ; the Gothic portions to the fourteenth ; some of the altars and embellishments to the fifteenth and sixteenth ; and the modern portion of the mosaics to the seventeenth.

§ ix. This, however, I only wish him to recollect in order that I may speak generally of the Byzantine architecture of St. Mark's, without leading him to suppose the whole church to have been built and decorated by Greek artists. Its later portions, with the single exception of the seventeenth century mosaics, have been so dexterously accommodated to the original fabric that the general effect is still that of a Byzantine building ; and I shall not, except when it is absolutely necessary, direct attention to the discordant points, or weary the reader with anatomical criticism. Whatever in St. Mark's

* Guida di Venezia, p. 6.

arrests the eye, or affects the feelings, is either Byzantine, or has been modified by Byzantine influence ; and our inquiry into its architectural merits need not therefore be disturbed by the anxieties of antiquarianism, or arrested by the obscurities of chronology.

§ x. And now I wish that the reader, before I bring him into St. Mark's Place, would imagine himself for a little time in a quiet English cathedral town, and walk with me to the west front of its cathedral. Let us go together up the more retired street, at the end of which we can see the pinnacles of one of the towers, and then through the low grey gateway, with its battlemented top and small latticed window in the centre, into the inner private-looking road or close, where nothing goes in but the carts of the tradesmen who supply the bishop and the chapter, and where there are little shaven grassplots, fenced in by neat rails, before old-fashioned groups of somewhat diminutive and excessively trim houses, with little oriel and bay windows jutting out here and there, and deep wooden cornices and eaves painted cream color and white, and small porches to their doors in the shape of cockle-shells, or little, crooked, thick, indescribable wooden gables warped a little on one side ; and so forward till we come to larger houses, also old-fashioned, but of red brick, and with gardens behind them, and fruit walls, which show here and there, among the nectarines, the vestiges of an old cloister arch or shaft, and looking in front on the cathedral square itself, laid out in rigid divisions of smooth grass and gravel walk, yet not uncheerful, especially on the sunny side where the canon's children are walking with their nurserymaids. And so, taking care not to tread on the grass, we will go along the straight walk to the west front, and there stand for a time, looking up at its deep-pointed porches and the dark places between their pillars where there were statues once, and where the fragments, here and there, of a stately figure are still left, which has in it the likeness of a king, perhaps indeed a king on earth, perhaps a saintly king long ago in heaven ; and so higher and higher up to the great mouldering wall of rugged sculpture and confused arcades, shattered,

and grey, and grisly with heads of dragons and mocking fiends, worn by the rain and swirling winds into yet unseemlier shape, and colored on their stony scales by the deep russet-orange lichen, melancholy gold ; and so, higher still, to the bleak towers, so far above that the eye loses itself among the bosses of their traceries, though they are rude and strong, and only sees like a drift of eddying black points, now closing, now scattering, and now settling suddenly into invisible places among the bosses and flowers, the crowd of restless birds that fill the whole square with that strange clangor of theirs, so harsh and yet so soothing, like the cries of birds on a solitary coast between the cliffs and sea.

§ XI. Think for a little while of that scene, and the meaning of all its small formalisms, mixed with its serene sublimity. Estimate its secluded, continuous, drowsy felicities, and its evidence of the sense and steady performance of such kind of duties as can be regulated by the cathedral clock ; and weigh the influence of those dark towers on all who have passed through the lonely square at their feet for centuries, and on all who have seen them rising far away over the wooded plain, or catching on their square masses the last rays of the sunset, when the city at their feet was indicated only by the mist at the bend of the river. And then let us quickly recollect that we are in Venice, and land at the extremity of the Calla Lunga San Moisè, which may be considered as there answering to the secluded street that led us to our English cathedral gateway.

§ XII. We find ourselves in a paved alley, some seven feet wide where it is widest, full of people, and resonant with cries of itinerant salesmen,—a shriek in their beginning, and dying away into a kind of brazen ringing, all the worse for its confinement between the high houses of the passage along which we have to make our way. Over-head an inextricable confusion of rugged shutters, and iron balconies and chimney flues pushed out on brackets to save room, and arched windows with projecting sills of Istrian stone, and gleams of green leaves here and there where a fig-tree branch escapes over a lower wall from some inner cortile, leading the eye up to the

narrow stream of blue sky high over all. On each side, a row of shops, as densely set as may be, occupying, in fact, intervals between the square stone shafts, about eight feet high, which carry the first floors : intervals of which one is narrow and serves as a door ; the other is, in the more respectable shops, wainscoted to the height of the counter and glazed above, but in those of the poorer tradesmen left open to the ground, and the wares laid on benches and tables in the open air, the light in all cases entering at the front only, and fading away in a few feet from the threshold into a gloom which the eye from without cannot penetrate, but which is generally broken by a ray or two from a feeble lamp at the back of the shop, suspended before a print of the Virgin. The less pious shop-keeper sometimes leaves his lamp unlighted, and is contented with a penny print ; the more religious one has his print colored and set in a little shrine with a gilded or figured fringe, with perhaps a faded flower or two on each side, and his lamp burning brilliantly. Here at the fruiterer's, where the dark-green water-melons are heaped upon the counter like cannon balls, the Madonna has a tabernacle of fresh laurel leaves ; but the pewterer next door has let his lamp out, and there is nothing to be seen in his shop but the dull gleam of the studded patterns on the copper pans, hanging from his roof in the darkness. Next comes a "Vendita Frittole e Liquori," where the Virgin, enthroned in a very humble manner beside a tallow candle on a back shelf, presides over certain ambrosial morsels of a nature too ambiguous to be defined or enumerated. But a few steps farther on, at the regular wine-shop of the calle, where we are offered "Vino Nostrani a Soldi 28·32," the Madonna is in great glory, enthroned above ten or a dozen large red casks of three-year-old vintage, and flanked by goodly ranks of bottles of Maraschino, and two crimson lamps ; and for the evening, when the gondoliers will come to drink out, under her auspices, the money they have gained during the day, she will have a whole chandelier.

§ XIII. A yard or two farther, we pass the hostelry of the Black Eagle, and, glancing as we pass through the square door of marble, deeply moulded, in the outer wall, we see the shad-

ows of its pergola of vines resting on an ancient well, with a pointed shield carved on its side ; and so presently emerge on the bridge and Campo San Moisè, whence to the entrance into St. Mark's Place, called the Bocca di Piazza (mouth of the square), the Venetian character is nearly destroyed, first by the frightful façade of San Moisè, which we will pause at another time to examine, and then by the modernizing of the shops as they near the piazza, and the mingling with the lower Venetian populace of lounging groups of English and Austrians. We will push fast through them into the shadow of the pillars at the end of the " Bocca di Piazza," and then we forget them all ; for between those pillars there opens a great light, and, in the midst of it, as we advance slowly, the vast tower of St. Mark seems to lift itself visibly forth from the level field of chequered stones ; and, on each side, the countless arches prolong themselves into ranged symmetry, as if the rugged and irregular houses that pressed together above us in the dark alley had been struck back into sudden obedience and lovely order, and all their rude casements and broken walls had been transformed into arches charged with goodly sculpture, and fluted shafts of delicate stone.

§ xiv. And well may they fall back, for beyond those troops of ordered arches there rises a vision out of the earth, and all the great square seems to have opened from it in a kind of awe, that we may see it far away ;—a multitude of pillars and white domes, clustered into a long low pyramid of colored light ; a treasure-heap, it seems, partly of gold, and partly of opal and mother-of-pearl, hollowed beneath into five great vaulted porches, ceiled with fair mosaic, and beset with sculpture of alabaster, clear as amber and delicate as ivory,—sculpture fantastic and involved, of palm leaves and lilies, and grapes and pomegranates, and birds clinging and fluttering among the branches, all twined together into an endless network of buds and plumes ; and, in the midst of it, the solemn forms of angels, sceptred, and robed to the feet, and leaning to each other across the gates, their figures indistinct among the gleaming of the golden ground through the leaves beside them, interrupted and dim, like the morn-

ing light as it faded back among the branches of Eden, when first its gates were angel-guarded long ago. And round the walls of the porches there are set pillars of variegated stones, jasper and porphyry, and deep-green serpentine spotted with flakes of snow, and marbles, that half refuse and half yield to the sunshine, Cleopatra-like, "their bluest veins to kiss"—the shadow, as it steals back from them, revealing line after line of azure undulation, as a receding tide leaves the waved sand; their capitals rich with interwoven tracery, rooted knots of herbage, and drifting leaves of acanthus and vine, and mystical signs, all beginning and ending in the Cross; and above them, in the broad archivolts, a continuous chain of language and of life—angels, and the signs of heaven, and the labors of men, each in its appointed season upon the earth; and above these, another range of glittering pinnacles, mixed with white arches edged with scarlet flowers,—a confusion of delight, amidst which the breasts of the Greek horses are seen blazing in their breadth of golden strength, and the St. Mark's Lion, lifted on a blue field covered with stars, until at last, as if in ecstasy, the crests of the arches break into a marble foam, and toss themselves far into the blue sky in flashes and wreaths of sculptured spray, as if the breakers on the Lido shore had been frost-bound before they fell, and the sea-nymphs had inlaid them with coral and amethyst.

Between that grim cathedral of England and this, what an interval! There is a type of it in the very birds that haunt them; for, instead of the restless crowd, hoarse-voiced and sable-winged, drifting on the bleak upper air, the St. Mark's porches are full of doves, that nestle among the marble foliage, and mingle the soft iridescence of their living plumes, changing at every motion, with the tints, hardly less lovely, that have stood unchanged for seven hundred years.

§ xv. And what effect has this splendor on those who pass beneath it? You may walk from sunrise to sunset, to and fro, before the gateway of St. Mark's, and you will not see an eye lifted to it, nor a countenance brightened by it. Priest and layman, soldier and civilian, rich and poor, pass by it

alike regardlessly. Up to the very recesses of the porches, the meanest tradesmen of the city push their counters; nay, the foundations of its pillars are themselves the seats—not “of them that sell doves” for sacrifice, but of the vendors of toys and caricatures. Round the whole square in front of the church there is almost a continuous line of cafés, where the idle Venetians of the middle classes lounge, and read empty journals; in its centre the Austrian bands play during the time of vespers, their martial music jarring with the organ notes,—the march drowning the miserere, and the sullen crowd thickening round them,—a crowd, which, if it had its will, would stiletto every soldier that pipes to it. And in the recesses of the porches, all day long, knots of men of the lowest classes, unemployed and listless, lie basking in the sun like lizards; and unregarded children,—every heavy glance of their young eyes full of desperation and stony depravity, and their throats hoarse with cursing,—gamble, and fight, and snarl, and sleep, hour after hour, clashing their bruised centesimi upon the marble ledges of the church porch. And the images of Christ and His angels look down upon it continually.

That we may not enter the church out of the midst of the horror of this, let us turn aside under the portico which looks towards the sea, and passing round within the two massive pillars brought from St. Jean d’Acre, we shall find the gate of the Baptistery; let us enter there. The heavy door closes behind us instantly, and the light, and the turbulence of the Piazzetta, are together shut out by it.

§ XVI. We are in a low vaulted room; vaulted, not with arches, but with small cupolas starred with gold, and chequered with gloomy figures: in the centre is a bronze font charged with rich bas-reliefs, a small figure of the Baptist standing above it in a single ray of light that glances across the narrow room, dying as it falls from a window high in the wall, and the first thing that it strikes, and the only thing that it strikes brightly, is a tomb. We hardly know if it be a tomb indeed; for it is like a narrow couch set beside the window, low-roofed and curtained, so that it might seem, but that

it has some height above the pavement, to have been drawn towards the window, that the sleeper might be wakened early ;—only there are two angels who have drawn the curtain back, and are looking down upon him. Let us look also, and thank that gentle light that rests upon his forehead for ever, and dies away upon his breast.

The face is of a man in middle life, but there are two deep furrows right across the forehead, dividing it like the foundations of a tower : the height of it above is bound by the fillet of the ducal cap. The rest of the features are singularly small and delicate, the lips sharp, perhaps the sharpness of death being added to that of the natural lines ; but there is a sweet smile upon them, and a deep serenity upon the whole countenance. The roof of the canopy above has been blue, filled with stars ; beneath, in the centre of the tomb on which the figure rests, is a seated figure of the Virgin, and the border of it all around is of flowers and soft leaves, growing rich and deep, as if in a field in summer.

It is the Doge Andrea Dandolo, a man early great among the great of Venice ; and early lost. She chose him for her king in his 36th year ; he died ten years later, leaving behind him that history to which we owe half of what we know of her former fortunes.

§ XVII. Look round at the room in which he lies. The floor of it is of rich mosaic, encompassed by a low seat of red marble, and its walls are of alabaster, but worn and shattered, and darkly stained with age, almost a ruin,—in places the slabs of marble have fallen away altogether, and the rugged brick-work is seen through the rents, but all beautiful ; the ravaging fissures fretting their way among the islands and channelled zones of the alabaster, and the time-stains on its translucent masses darkened into fields of rich golden brown, like the color of seaweed when the sun strikes on it through deep sea. The light fades away into the recess of the chamber towards the altar, and the eye can hardly trace the lines of the bas-relief behind it of the baptism of Christ : but on the vaulting of the roof the figures are distinct, and there are seen upon it two great circles, one surrounded by the “ Prin-

cipalities and powers in heavenly places," of which Milton has expressed the ancient division in the single massy line,

"Thrones, Dominations, Princedoms, Virtues, Powers,"

and around the other, the Apostles ; Christ the centre of both ; and upon the walls, again and again repeated, the gaunt figure of the Baptist, in every circumstance of his life and death ; and the streams of the Jordan running down between their cloven rocks ; the axe laid to the root of a fruitless tree that springs upon their shore. "Every tree that bringeth not forth good fruit shall be hewn down, and cast into the fire." Yes, verily : to be baptized with fire, or to be cast therein ; it is the choice set before all men. The march-notes still murmur through the grated window, and mingle with the sounding in our ears of the sentence of judgment, which the old Greek has written on that Baptistery wall. Venice has made her choice.

§ xviii. He who lies under that stony canopy would have taught her another choice, in his day, if she would have listened to him ; but he and his counsels have long been forgotten by her, and the dust lies upon his lips.

Through the heavy door whose bronze network closes the place of his rest, let us enter the church itself. It is lost in still deeper twilight, to which the eye must be accustomed for some moments before the form of the building can be traced ; and then there opens before us a vast cave, hewn out into the form of a Cross, and divided into shadowy aisles by many pillars. Round the domes of its roof the light enters only through narrow apertures like large stars ; and here and there a ray or two from some far away casement wanders into the darkness, and casts a narrow phosphoric stream upon the waves of marble that heave and fall in a thousand colors along the floor. What else there is of light is from torches, or silver lamps, burning ceaselessly in the recesses of the chapels ; the roof sheeted with gold, and the polished walls covered with alabaster, give back at every curve and angle some feeble gleaming to the flames ; and the glories round the heads of the sculptured saints flash out upon us as we pass them, and sink again into the gloom. Under foot and over head, a con-

tinual succession of crowded imagery, one picture passing into another, as in a dream ; forms beautiful and terrible mixed together ; dragons and serpents, and ravening beasts of prey, and graceful birds that in the midst of them drink from running fountains and feed from vases of crystal ; the passions and the pleasures of human life symbolized together, and the mystery of its redemption ; for the mazes of interwoven lines and changeful pictures lead always at last to the Cross, lifted and carved in every place and upon every stone ; sometimes with the serpent of eternity wrapt round it, sometimes with doves beneath its arms, and sweet herbage growing forth from its feet ; but conspicuous most of all on the great rood that crosses the church before the altar, raised in bright blazonry against the shadow of the apse. And although in the recesses of the aisle and chapels, when the mist of the incense hangs heavily, we may see continually a figure traced in faint lines upon their marble, a woman standing with her eyes raised to heaven, and the inscription above her, "Mother of God," she is not here the presiding deity. It is the Cross that is first seen, and always, burning in the centre of the temple ; and every dome and hollow of its roof has the figure of Christ in the utmost height of it, raised in power, or returning in judgment.

§ XIX. Nor is this interior without effect on the minds of the people. At every hour of the day there are groups collected before the various shrines, and solitary worshippers scattered through the darker places of the church, evidently in prayer both deep and reverent, and, for the most part, profoundly sorrowful. The devotees at the greater number of the renowned shrines of Romanism may be seen murmuring their appointed prayers with wandering eyes and unengaged gestures ; but the step of the stranger does not disturb those who kneel on the pavement of St. Mark's ; and hardly a moment passes, from early morning to sunset, in which we may not see some half-veiled figure enter beneath the Arabian porch, cast itself into long abasement on the floor of the temple, and then rising slowly with more confirmed step, and with a passionate kiss and clasp of the arms given to the

feet of the crucifix, by which the lamps burn always in the northern aisle, leave the church, as if comforted.

§ xx. But we must not hastily conclude from this that the nobler characters of the building have at present any influence in fostering a devotional spirit. There is distress enough in Venice to bring many to their knees, without excitement from external imagery; and whatever there may be in the temper of the worship offered in St. Mark's more than can be accounted for by reference to the unhappy circumstances of the city, is assuredly not owing either to the beauty of its architecture or to the impressiveness of the Scripture histories embodied in its mosaics. That it has a peculiar effect, however slight, on the popular mind, may perhaps be safely conjectured from the number of worshippers which it attracts, while the churches of St. Paul and the Frari, larger in size and more central in position, are left comparatively empty.* But this effect is altogether to be ascribed to its richer assemblage of those sources of influence which address themselves to the commonest instincts of the human mind, and which, in all ages and countries, have been more or less employed in the support of superstition. Darkness and mystery; confused recesses of building; artificial light employed in small quantity, but maintained with a constancy which seems to give it a kind of sacredness; preciousness of material easily comprehended by the vulgar eye; close air loaded with a sweet and peculiar odor associated only with religious services, solemn music, and tangible idols or images having popular legends attached to them,—these, the stage properties of superstition, which have been from the beginning of the world, and must be to the end of it, employed by all nations, whether openly savage or nominally civilized, to produce a false awe in minds incapable of apprehending the true nature of the Deity, are assembled in St. Mark's to a degree, as far as I know, unexampled in any other European church. The arts of the Magus

* The mere warmth of St. Mark's in winter, which is much greater than that of the other two churches above named, must, however, be taken into consideration, as one of the most efficient causes of its being then more frequented.

and the Brahmin are exhausted in the animation of a paralyzed Christianity ; and the popular sentiment which these arts excite is to be regarded by us with no more respect than we should have considered ourselves justified in rendering to the devotion of the worshippers at Eleusis, Ellora, or Edfou.*

§ XXI. Indeed, these inferior means of exciting religious emotion were employed in the ancient Church as they are at this day, but not employed alone. Torchlight there was, as there is now ; but the torchlight illumined Scripture histories on the walls, which every eye traced and every heart comprehended, but which, during my whole residence in Venice, I never saw one Venetian regard for an instant. I never heard from any one the most languid expression of interest in any feature of the church, or perceived the slightest evidence of their understanding the meaning of its architecture ; and while, therefore, the English cathedral, though no longer dedicated to the kind of services for which it was intended by its builders, and much at variance in many of its characters with the temper of the people by whom it is now surrounded, retains yet so much of its religious influence that no prominent feature of its architecture can be said to exist altogether in vain, we have in St. Mark's a building apparently still employed in the ceremonies for which it was designed, and yet of which the impressive attributes have altogether ceased to be comprehended by its votaries. The beauty which it possesses is unfelt, the language it uses is forgotten ; and in the midst of the city to whose service it has so long been consecrated, and still filled by crowds of the descendants of those to whom it owes its magnificence, it stands, in reality, more desolate than the

* I said above that the larger number of the devotees entered by the "Arabian" porch ; the porch, that is to say, on the north side of the church, remarkable for its rich Arabian archivolt, and through which access is gained immediately to the northern transept. The reason is, that in that transept is the chapel of the Madonna, which has a greater attraction for the Venetians than all the rest of the church besides. The old builders kept their images of the Virgin subordinate to those of Christ ; but modern Romanism has retrograded from theirs, and the most glittering portions of the whole church are the two recesses behind this lateral altar, covered with silver hearts dedicated to the Virgin.

ruins through which the sheep-walk passes unbroken in our English valleys ; and the writing on its marble walls is less regarded and less powerful for the teaching of men, than the letters which the shepherd follows with his finger, where the moss is lightest on the tombs in the desecrated cloister.

§ XXII. It must therefore be altogether without reference to its present usefulness, that we pursue our inquiry into the merits and meaning of the architecture of this marvellous building ; and it can only be after we have terminated that inquiry, conducting it carefully on abstract grounds, that we can pronounce with any certainty how far the present neglect of St. Mark's is significative of the decline of the Venetian character, or how far this church is to be considered as the relic of a barbarous age, incapable of attracting the admiration, or influencing the feelings of a civilized community.

The inquiry before us is twofold. Throughout the first volume, I carefully kept the study of *expression* distinct from that of abstract architectural perfection ; telling the reader that in every building we should afterwards examine, he would have first to form a judgment of its construction and decorative merit, considering it merely as a work of art ; and then to examine farther, in what degree it fulfilled its expressional purposes. Accordingly, we have first to judge of St. Mark's merely as a piece of architecture, not as a church ; secondly, to estimate its fitness for its special duty as a place of worship, and the relation in which it stands, as such, to those northern cathedrals that still retain so much of the power over the human heart, which the Byzantine domes appear to have lost for ever.

§ XXIII. In the two succeeding sections of this work, devoted respectively to the examination of the Gothic and Renaissance buildings in Venice, I have endeavored to analyze and state, as briefly as possible, the true nature of each school,—first in Spirit, then in Form. I wished to have given a similar analysis, in this section, of the nature of Byzantine architecture ; but could not make my statements general, because I have never seen this kind of building on its native soil. Nevertheless, in the following sketch of the principles exemplified

in St. Mark's, I believe that most of the leading features and motives of the style will be found clearly enough distinguished to enable the reader to judge of it with tolerable fairness, as compared with the better known systems of European architecture in the middle ages.

§ xxiv. Now the first broad characteristic of the building, and the root nearly of every other important peculiarity in it, is its confessed *incrustation*. It is the purest example in Italy of the great school of architecture in which the ruling principle is the incrustation of brick with more precious materials; and it is necessary before we proceed to criticise any one of its arrangements, that the reader should carefully consider the principles which are likely to have influenced, or might legitimately influence, the architects of such a school, as distinguished from those whose designs are to be executed in massive materials.

It is true, that among different nations, and at different times, we may find examples of every sort and degree of incrustation, from the mere setting of the larger and more compact stones by preference at the outside of the wall, to the miserable construction of that modern brick cornice, with its coating of cement, which, but the other day, in London, killed its unhappy workmen in its fall.* But just as it is perfectly possible to have a clear idea of the opposing characteristics of two different species of plants or animals, though between the two there are varieties which it is difficult to assign either to the one or the other, so the reader may fix decisively in his mind the legitimate characteristics of the incrustated and the massive styles, though between the two there are varieties which confessedly unite the attributes of both. For instance, in many Roman remains, built of blocks of tufa and incrustated with marble, we have a style, which, though truly solid, possesses some of the attributes of incrustation; and in the Cathedral of Florence, built of brick and coated with marble, the marble facing is so firmly and exquisitely set, that the building, though in reality incrustated, assumes the attributes of solidity. But these intermediate examples need not in the

* Vide "Builder," for October, 1851.

least confuse our generally distinct ideas of the two families of buildings : the one in which the substance is alike throughout, and the forms and conditions of the ornament assume or prove that it is so, as in the best Greek buildings, and for the most part in our early Norman and Gothic ; and the other, in which the substance is of two kinds, one internal, the other external, and the system of decoration is founded on this duplicity, as pre-eminently in St. Mark's.

§ xxv. I have used the word duplicity in no depreciatory sense. In chapter ii. of the "Seven Lamps," § 18, I especially guarded this incrustated school from the imputation of insincerity, and I must do so now at greater length. It appears insincere at first to a Northern builder, because, accustomed to build with solid blocks of freestone, he is in the habit of supposing the external superficies of a piece of masonry to be some criterion of its thickness. But, as soon as he gets acquainted with the incrustated style, he will find that the Southern builders had no intention to deceive him. He will see that every slab of facial marble is fastened to the next by a confessed *rivet*, and that the joints of the armor are so visibly and openly accommodated to the contours of the substance within, that he has no more right to complain of treachery than a savage would have, who, for the first time in his life seeing a man in armor, had supposed him to be made of solid steel. Acquaint him with the customs of chivalry, and with the uses of the coat of mail, and he ceases to accuse of dishonesty either the panoply or the knight.

These laws and customs of the St. Mark's architectural chivalry it must be our business to develop.

§ xxvi. First, consider the natural circumstances which give rise to such a style. Suppose a nation of builders, placed far from any quarries of available stone, and having precarious access to the mainland where they exist ; compelled therefore either to build entirely with brick, or to import whatever stone they use from great distances, in ships of small tonnage, and for the most part dependent for speed on the oar rather than the sail. The labor and cost of carriage are just as great, whether they import common or precious

stone, and therefore the natural tendency would always be to make each shipload as valuable as possible. But in proportion to the preciousness of the stone, is the limitation of its possible supply; limitation not determined merely by cost, but by the physical conditions of the material, for of many marbles, pieces above a certain size are not to be had for money. There would also be a tendency in such circumstances to import as much stone as possible ready sculptured, in order to save weight; and therefore, if the traffic of their merchants led them to places where there were ruins of ancient edifices, to ship the available fragments of them home. Out of this supply of marble, partly composed of pieces of so precious a quality that only a few tons of them could be on any terms obtained, and partly of shafts, capitals, and other portions of foreign buildings, the island architect has to fashion, as best he may, the anatomy of his edifice. It is at his choice either to lodge his few blocks of precious marble here and there among his masses of brick, and to cut out of the sculptured fragments such new forms as may be necessary for the observance of fixed proportions in the new building; or else to cut the colored stones into thin pieces, of extent sufficient to face the whole surface of the walls, and to adopt a method of construction irregular enough to admit the insertion of fragmentary sculptures; rather with a view of displaying their intrinsic beauty, than of setting them to any regular service in the support of the building.

An architect who cared only to display his own skill, and had no respect for the works of others, would assuredly have chosen the former alternative, and would have sawn the old marbles into fragments in order to prevent all interference with his own designs. But an architect who cared for the preservation of noble work, whether his own or others', and more regarded the beauty of his building than his own fame, would have done what those old builders of St. Mark's did for us, and saved every relic with which he was entrusted.

§ XXVII. But these were not the only motives which influenced the Venetians in the adoption of their method of architecture. It might, under all the circumstances above stated,

have been a question with other builders, whether to import one shipload of costly jaspers, or twenty of chalk flints; and whether to build a small church faced with porphyry and paved with agate, or to raise a vast cathedral in freestone. But with the Venetians it could not be a question for an instant; they were exiles from ancient and beautiful cities, and had been accustomed to build with their ruins, not less in affection than in admiration: they had thus not only grown familiar with the practice of inserting older fragments in modern buildings, but they owed to that practice a great part of the splendor of their city, and whatever charm of association might aid its change from a Refuge into a Home. The practice which began in the affections of a fugitive nation, was prolonged in the pride of a conquering one; and beside the memorials of departed happiness, were elevated the trophies of returning victory. The ship of war brought home more marble in triumph than the merchant vessel in speculation; and the front of St. Mark's became rather a shrine at which to dedicate the splendor of miscellaneous spoil, than the organized expression of any fixed architectural law, or religious emotion.

§ XXVIII. Thus far, however, the justification of the style of this church depends on circumstances peculiar to the time of its erection, and to the spot where it arose. The merit of its method, considered in the abstract, rests on far broader grounds.

In the fifth chapter of the "Seven Lamps," § 14, the reader will find the opinion of a modern architect of some reputation, Mr. Wood, that the chief thing remarkable in this church "is its extreme ugliness;" and he will find this opinion associated with another, namely, that the works of the Caracci are far preferable to those of the Venetian painters. This second statement of feeling reveals to us one of the principal causes of the first; namely, that Mr. Wood had not any perception of color, or delight in it. The perception of color is a gift just as definitely granted to one person, and denied to another, as an ear for music; and the very first requisite for true judgment of St. Mark's, is the perfection of that color-faculty which

few people ever set themselves seriously to find out whether they possess or not. For it is on its value as a piece of perfect and unchangeable coloring, that the claims of this edifice to our respect are finally rested ; and a deaf man might as well pretend to pronounce judgment on the merits of a full orchestra, as an architect trained in the composition of form only, to discern the beauty of St. Mark's. It possesses the charm of color in common with the greater part of the architecture, as well as of the manufactures, of the East ; but the Venetians deserve especial note as the only European people who appear to have sympathized to the full with the great instinct of the Eastern races. They indeed were compelled to bring artists from Constantinople to design the mosaics of the vaults of St. Mark's, and to group the colors of its porches ; but they rapidly took up and developed, under more masculine conditions, the system of which the Greeks had shown them the example : while the burghers and barons of the North were building their dark streets and grisly castles of oak and sandstone, the merchants of Venice were covering their palaces with porphyry and gold ; and at last, when her mighty painters had created for her a color more priceless than gold or porphyry, even this, the richest of her treasures, she lavished upon walls whose foundations were beaten by the sea ; and the strong tide, as it runs beneath the Rialto, is reddened to this day by the reflection of the frescoes of Giorgione.

§ XXIX. If, therefore, the reader does not care for color, I must protest against his endeavor to form any judgment whatever of this church of St. Mark's. But, if he both cares for and loves it, let him remember that the school of incrustated architecture is *the only one in which perfect and permanent chromatic decoration is possible* ; and let him look upon every piece of jasper and alabaster given to the architect as a cake of very hard color, of which a certain portion is to be ground down or cut off, to paint the walls with. Once understand this thoroughly, and accept the condition that the body and availing strength of the edifice are to be in brick, and that this under muscular power of brickwork is to be clothed with the defence and the brightness of the marble, as the body of

of an animal is protected and adorned by its scales or its skin, and all the consequent fitnesses and laws of the structure will be easily discernible : These I shall state in their natural order.

§ XXX. LAW I. *That the plinths and cornices used for binding the armor are to be light and delicate.* A certain thickness, at least two or three inches, must be required in the covering pieces (even when composed of the strongest stone, and set on the least exposed parts), in order to prevent the chance of fracture, and to allow for the wear of time. And the weight of this armor must not be trusted to cement ; the pieces must not be merely glued to the rough brick surface, but connected with the mass which they protect by binding cornices and string courses ; and with each other, so as to secure mutual support, aided by the rivetings, but by no means dependent upon them. And, for the full honesty and straightforwardness of the work, it is necessary that these string courses and binding plinths should not be of such proportions as would fit them for taking any important part in the hard work of the inner structure, or render them liable to be mistaken for the great cornices and plinths already explained as essential parts of the best solid building. They must be delicate, slight, and visibly incapable of severer work than that assigned to them.

§ XXXI. LAW II. *Science of inner structure is to be abandoned.* As the body of the structure is confessedly of inferior, and comparatively incoherent materials, it would be absurd to attempt in it any expression of the higher refinements of construction. It will be enough that by its mass we are assured of its sufficiency and strength ; and there is the less reason for endeavoring to diminish the extent of its surface by delicacy of adjustment, because on the breadth of that surface we are to depend for the better display of the color, which is to be the chief source of our pleasure in the building. The main body of the work, therefore, will be composed of solid walls and massive piers ; and whatever expression of finer structural science we may require, will be thrown either into subordinate portions of it, or entirely directed to the support of the external mail, where in arches or vaults it might otherwise appear dangerously independent of the material within.

§ xxxii. LAW III. *All shafts are to be solid.* Wherever, by the smallness of the parts, we may be driven to abandon the incrustated structure at all, it must be abandoned altogether. The eye must never be left in the least doubt as to what is solid and what is coated. Whatever appears *probably* solid, must be *assuredly* so, and therefore it becomes an inviolable law that no shaft shall ever be incrustated. Not only does the whole virtue of a shaft depend on its consolidation, but the labor of cutting and adjusting an incrustated coat to it would be greater than the saving of material is worth. Therefore the shaft, of whatever size, is always to be solid; and because the incrustated character of the rest of the building renders it more difficult for the shafts to clear themselves from suspicion, they must not, in this incrustated style, be in any place jointed. No shaft must ever be used but of one block; and this the more, because the permission given to the builder to have his walls and piers as ponderous as he likes, renders it quite unnecessary for him to use shafts of any fixed size. In our Norman and Gothic, where definite support is required at a definite point, it becomes lawful to build up a tower of small stones in the shape of a shaft. But the Byzantine is allowed to have as much support as he wants from the walls in every direction, and he has no right to ask for further license in the structure of his shafts. Let him, by generosity in the substance of his pillars, repay us for the permission we have given him to be superficial in his walls. The builder in the chalk valleys of France and England may be blameless in kneading his clumsy pier out of broken flint and calcined lime; but the Venetian, who has access to the riches of Asia and the quarries of Egypt, must frame at least his shafts out of flawless stone.

§ xxxiii. And this for another reason yet. Although, as we have said, it is impossible to cover the walls of a large building with color, except on the condition of dividing the stone into plates, there is always a certain appearance of meanness and niggardliness in the procedure. It is necessary that the builder should justify himself from this suspicion; and prove that it is not in mere economy or poverty, but in the real impossibility of doing otherwise, that he has sheeted his

walls so thinly with the precious film. Now the shaft is exactly the portion of the edifice in which it is fittest to recover his honor in this respect. For if blocks of jasper or porphyry be inserted in the walls, the spectator cannot tell their thickness, and cannot judge of the costliness of the sacrifice. But the shaft he can measure with his eye in an instant, and estimate the quantity of treasure both in the mass of its existing substance, and in that which has been hewn away to bring it into its perfect and symmetrical form. And thus the shafts of all buildings of this kind are justly regarded as an expression of their wealth, and a form of treasure, just as much as the jewels or gold in the sacred vessels; they are, in fact, nothing else than large jewels,* the block of precious serpentine or jasper being valued according to its size and brilliancy of color, like a large emerald or ruby; only the bulk required to bestow value on the one is to be measured in feet and tons, and on the other in lines and carats. The shafts must therefore be, without exception, of one block in all buildings of this kind; for the attempt in any place to incrust or joint them would be a deception like that of introducing a false stone among jewellery (for a number of joints of any precious stone are of course not equal in value to a single piece of equal weight), and would put an end at once to the spectator's confidence in the expression of wealth in any portion of the structure, or of the spirit of sacrifice in those who raised it.

§ XXXIV. LAW IV. *The shafts may sometimes be independent of the construction.* Exactly in proportion to the importance which the shaft assumes as a large jewel, is the diminution of its importance as a sustaining member; for the delight which we receive in its abstract bulk, and beauty of color, is altogether independent of any perception of its adaptation to mechanical necessities. Like other beautiful things in this

* “Quivi presso si vedi una colonna di tanta bellezza e finezza che e riputato piuttosto gioia che pietra.”—*Sansorino*, of the verd-antique pillar in San Jacomo dell' Orto. A remarkable piece of natural history and moral philosophy, connected with this subject, will be found in the second chapter of our third volume, quoted from the work of a Florentine architect of the fifteenth century.

world, its end is to *be* beautiful; and, in proportion to its beauty, it receives permission to be otherwise useless. We do not blame emeralds and rubies because we cannot make them into heads of hammers. Nay, so far from our admiration of the jewel shaft being dependent on its doing work for us, it is very possible that a chief part of its preciousness may consist in a delicacy, fragility, and tenderness of material, which must render it utterly unfit for hard work; and therefore that we shall admire it the more, because we perceive that if we were to put much weight upon it, it would be crushed. But, at all events, it is very clear that the primal object in the placing of such shafts must be the display of their beauty to the best advantage, and that therefore all imbedding of them in walls, or crowding of them into groups, in any position in which either their real size or any portion of their surface would be concealed, is either inadmissible altogether, or objectionable in proportion to their value; that no symmetrical or scientific arrangements of pillars are therefore ever to be expected in buildings of this kind, and that all such are even to be looked upon as positive errors and misapplications of materials: but that, on the contrary, we must be constantly prepared to see, and to see with admiration, shafts of great size and importance set in places where their real service is little more than nominal, and where the chief end of their existence is to catch the sunshine upon their polished sides, and lead the eye into delighted wandering among the mazes of their azure veins.

§ xxxv. LAW V. *The shafts may be of variable size.* Since the value of each shaft depends upon its bulk, and diminishes with the diminution of its mass, in a greater ratio than the size itself diminishes, as in the case of all other jewellery, it is evident that we must not in general expect perfect symmetry and equality among the series of shafts, any more than definiteness of application; but that, on the contrary, an accurately observed symmetry ought to give us a kind of pain, as proving that considerable and useless loss has been sustained by some of the shafts, in being cut down to match with the rest. It is true that symmetry is generally sought for in

works of smaller jewellery ; but, even there, not a perfect symmetry, and obtained under circumstances quite different from those which affect the placing of shafts in architecture. First : the symmetry is usually imperfect. The stones that seem to match each other in a ring or necklace, appear to do so only because they are so small that their differences are not easily measured by the eye ; but there is almost always such difference between them as would be strikingly apparent if it existed in the same proportion between two shafts nine or ten feet in height. Secondly : the quantity of stones which pass through a jeweller's hands, and the facility of exchange of such small objects, enable the tradesman to select any number of stones of approximate size ; a selection, however, often requiring so much time, that perfect symmetry in a group of very fine stones adds enormously to their value. But the architect has neither the time nor the facilities of exchange. He cannot lay aside one column in a corner of his church till, in the course of traffic, he obtain another that will match it ; he has not hundreds of shafts fastened up in bundles, out of which he can match sizes at his ease ; he cannot send to a brother-tradesmen and exchange the useless stones for available ones, to the convenience of both. His blocks of stone, or his ready hewn shafts, have been brought to him in limited number, from immense distances ; no others are to be had ; and for those which he does not bring into use, there is no demand elsewhere. His only means of obtaining symmetry will therefore be, in cutting down the finer masses to equality with the inferior ones ; and this we ought not to desire him often to do. And therefore, while sometimes in a Baldacchino, or an important chapel or shrine, this costly symmetry may be necessary, and admirable in proportion to its probable cost, in the general fabric we must expect to see shafts introduced of size and proportion continually varying, and such symmetry as may be obtained among them never altogether perfect, and dependent for its charm frequently on strange complexities and unexpected rising and falling of weight and accent in its marble syllables ; bearing the same relation to a rigidly chiselled and proportioned architecture that the wild

lyric rhythm of Æschylus or Pindar bears to the finished measures of Pope.

§ xxxvi. The application of the principles of jewellery to the smaller as well as the larger blocks, will suggest to us another reason for the method of incrustation adopted in the walls. It often happens that the beauty of the veining in some varieties of alabaster is so great, that it becomes desirable to exhibit it by dividing the stone, not merely to economize its substance, but to display the changes in the disposition of its fantastic lines. By reversing one of two thin plates successively taken from the stone, and placing their corresponding edges in contact, a perfectly symmetrical figure may be obtained, which will enable the eye to comprehend more thoroughly the position of the veins. And this is actually the method in which, for the most part, the alabasters of St. Mark are employed; thus accomplishing a double good,—directing the spectator, in the first place, to close observation of the nature of the stone employed, and in the second, giving him a farther proof of the honesty of intention in the builder: for wherever similar veining is discovered in two pieces, the fact is declared that they have been cut from the same stone. It would have been easy to disguise the similarity by using them in different parts of the building; but on the contrary they are set edge to edge, so that the whole system of the architecture may be discovered at a glance by any one acquainted with the nature of the stones employed. Nay, but, it is perhaps answered me, not by an ordinary observer; a person ignorant of the nature of alabaster might perhaps fancy all these symmetrical patterns to have been found in the stone itself, and thus be doubly deceived, supposing blocks to be solid and symmetrical which were in reality subdivided and irregular. I grant it; but be it remembered, that in all things, ignorance is liable to be deceived, and has no right to accuse anything but itself as the source of the deception. The style and the words are dishonest, not which are liable to be misunderstood if subjected to no inquiry, but which are deliberately calculated to lead inquiry astray. There are perhaps no great or noble truths, from those of religion downwards, which present no

mistakeable aspect to casual or ignorant contemplation. Both the truth and the lie agree in hiding themselves at first, but the lie continues to hide itself with effort, as we approach to examine it ; and leads us, if undiscovered, into deeper lies; the truth reveals itself in proportion to our patience and knowledge, discovers itself kindly to our pleading, and leads us, as it is discovered, into deeper truths.

§ XXXVII. LAW VI. *The decoration must be shallow in cutting.* The method of construction being thus systematized, it is evident that a certain style of decoration must arise out of it, based on the primal condition that over the greater part of the edifice there can be *no deep cutting*. The thin sheets of covering stones do not admit of it; we must not cut them through to the bricks; and whatever ornaments we engrave upon them cannot, therefore, be more than an inch deep at the utmost. Consider for an instant the enormous differences which this single condition compels between the sculptural decoration of the incrustated style, and that of the solid stones of the North, which may be hacked and hewn into whatever cavernous hollows and black recesses we choose; struck into grim darknesses and grotesque projections, and rugged ploughings up of sinuous furrows, in which any form or thought may be wrought out on any scale,—mighty statues with robes of rock and crowned foreheads burning in the sun, or venomous goblins and stealthy dragons shrunk into lurking-places of untraceable shade: think of this, and of the play and freedom given to the sculptor's hand and temper, to smite out and in, hither and thither, as he will; and then consider what must be the different spirit of the design which is to be wrought on the smooth surface of a film of marble, where every line and shadow must be drawn with the most tender pencilling and cautious reserve of resource,—where even the chisel must not strike hard, lest it break through the delicate stone, nor the mind be permitted in any impetuosity of conception inconsistent with the fine discipline of the hand. Consider that whatever animal or human form is to be suggested, must be projected on a flat surface; that all the features of the countenance, the folds of the drapery, the involutions of

the limbs, must be so reduced and subdued that the whole work becomes rather a piece of fine drawing than of sculpture; and then follow out, until you begin to perceive their endlessness, the resulting differences of character which will be necessitated in every part of the ornamental designs of these incrustated churches, as compared with that of the Northern schools. I shall endeavor to trace a few of them only.

§ xxxviii. The first would of course be a diminution of the builder's dependence upon human form as a source of ornament: since exactly in proportion to the dignity of the form itself is the loss which it must sustain in being reduced to a shallow and linear bas-relief, as well as the difficulty of expressing it at all under such conditions. Wherever sculpture can be solid, the nobler characters of the human form at once lead the artist to aim at its representation, rather than at that of inferior organisms; but when all is to be reduced to outline, the forms of flowers and lower animals are always more intelligible, and are felt to approach much more to a satisfactory rendering of the objects intended, than the outlines of the human body. This inducement to seek for resources of ornament in the lower fields of creation was powerless in the minds of the great Pagan nations, Ninevite, Greek, or Egyptian: first, because their thoughts were so concentrated on their own capacities and fates, that they preferred the rudest suggestion of human form to the best of an inferior organism; secondly, because their constant practice in solid sculpture, often colossal, enabled them to bring a vast amount of science into the treatment of the lines, whether of the low relief, the monochrome vase, or shallow hieroglyphic.

§ xxxix. But when various ideas adverse to the representation of animal, and especially of human, form, originating with the Arabs and iconoclast Greeks, had begun at any rate to direct the builders' minds to seek for decorative materials in inferior types, and when diminished practice in solid sculpture had rendered it more difficult to find artists capable of satisfactorily reducing the high organisms to their elementary outlines, the choice of subject for surface sculpture would be more and more uninterruptedly directed to floral organ-

isms, and human and animal form would become diminished in size, frequency, and general importance. So that, while in the Northern solid architecture we constantly find the effect of its noblest features dependent on ranges of statues, often colossal, and full of abstract interest, independent of their architectural service, in the Southern incrustated style we must expect to find the human form for the most part subordinate and diminutive, and involved among designs of foliage and flowers, in the manner of which endless examples had been furnished by the fantastic ornamentation of the Romans, from which the incrustated style had been directly derived.

§ XL. Farther. In proportion to the degree in which his subject must be reduced to abstract outline will be the tendency in the sculptor to abandon naturalism of representation, and subordinate every form to architectural service. Where the flower or animal can be hewn into bold relief, there will always be a temptation to render the representation of it more complete than is necessary, or even to introduce details and intricacies inconsistent with simplicity of distant effect. Very often a worse fault than this is committed; and in the endeavor to give vitality to the stone, the original ornamental purpose of the design is sacrificed or forgotten. But when nothing of this kind can be attempted, and a slight outline is all that the sculptor can command, we may anticipate that this outline will be composed with exquisite grace; and that the richness of its ornamental arrangement will atone for the feebleness of its power of portraiture. On the porch of a Northern cathedral we may seek for the images of the flowers that grow in the neighboring fields, and as we watch with wonder the grey stones that fret themselves into thorns, and soften into blossoms, we may care little that these knots of ornament, as we retire from them to contemplate the whole building, appear unconsidered or confused. On the incrustated building we must expect no such deception of the eye or thoughts. It may sometimes be difficult to determine, from the involutions of its linear sculpture, what were the natural forms which originally suggested them: but we may confidently expect that the grace of their arrangement will

always be complete; that there will not be a line in them which could be taken away without injury, nor one wanting which could be added with advantage.

§ XLI. Farther. While the sculptures of the incrustated school will thus be generally distinguished by care and purity rather than force, and will be, for the most part, utterly wanting in depth of shadow, there will be one means of obtaining darkness peculiarly simple and obvious, and often in the sculptor's power. Wherever he can, without danger, leave a hollow behind his covering slabs, or use them, like glass, to fill an aperture in the wall, he can, by piercing them with holes, obtain points or spaces of intense blackness to contrast with the light tracing of the rest of his design. And we may expect to find this artifice used the more extensively, because, while it will be an effective means of ornamentation on the exterior of the building, it will be also the safest way of admitting light to the interior, still totally excluding both rain and wind. And it will naturally follow that the architect, thus familiarized with the effect of black and sudden points of shadow, will often seek to carry the same principle into other portions of his ornamentation, and by deep drill-holes, or perhaps inlaid portions of black color, to refresh the eye where it may be wearied by the lightness of the general handling.

§ XLII. Farther. Exactly in proportion to the degree in which the force of sculpture is subdued, will be the importance attached to color as a means of effect or constituent of beauty. I have above stated that the incrustated style was the only one in which perfect or permanent color decoration was possible. It is also the only one in which a true system of color decoration was ever likely to be invented. In order to understand this, the reader must permit me to review with some care the nature of the principles of coloring adopted by the Northern and Southern nations.

§ XLIII. I believe that from the beginning of the world there has never been a true or fine school of art in which color was despised. It has often been imperfectly attained and injudiciously applied, but I believe it to be one of the essential signs

of life in a school of art, that it loves color ; and I know it to be one of the first signs of death in the Renaissance schools, that they despise color.

Observe, it is not now the question whether our Northern cathedrals are better with color or without. Perhaps the great monotone grey of Nature and of Time is a better color than any that the human hand can give ; but that is nothing to our present business. The simple fact is, that the builders of those cathedrals laid upon them the brightest colors they could obtain, and that there is not, as far as I am aware, in Europe, any monument of a truly noble school which has not been either painted all over, or vigorously touched with paint, mosaic, and gilding in its prominent parts. Thus far Egyptians, Greeks, Goths, Arabs, and mediæval Christians all agree : none of them, when in their right senses, ever think of doing without paint ; and therefore, when I said above that the Venetians were the only people who had thoroughly sympathized with the Arabs in this respect, I referred, first, to their intense love of color, which led them to lavish the most expensive decorations on ordinary dwelling-houses ; and, secondly, to that perfection of the color-instinct in them, which enabled them to render whatever they did, in this kind, as just in principle as it was gorgeous in appliance. It is this principle of theirs, as distinguished from that of the Northern builders, which we have finally to examine.

§ XLIV. In the second chapter of the first volume, it was noticed that the architect of Bourges Cathedral liked hawthorn, and that the porch of his cathedral was therefore decorated with a rich wreath of it ; but another of the predilections of that architect was there unnoticed, namely, that he did not at all like *grey* hawthorn, but preferred it green, and he painted it green accordingly, as bright as he could. The color is still left in every sheltered interstice of the foliage. He had, in fact, hardly the choice of any other color ; he might have gilded the thorns, by way of allegorizing human life, but if they were to be painted at all, they could hardly be painted anything but green, and green all over. People would have been apt to object to any pursuit of abstract harmonies of

color, which might have induced him to paint his hawthorn blue.

§ XLV. In the same way, whenever the subject of the sculpture was definite, its color was of necessity definite also ; and, in the hands of the Northern builders, it often became, in consequence, rather the means of explaining and animating the stories of their stone-work, than a matter of abstract decorative science. Flowers were painted red, trees green, and faces flesh-color ; the result of the whole being often far more entertaining than beautiful. And also, though in the lines of the mouldings and the decorations of shafts or vaults, a richer and more abstract method of coloring was adopted (aided by the rapid development of the best principles of color in early glass-painting), the vigorous depths of shadow in the Northern sculpture confused the architect's eye, compelling him to use violent colors in the recesses, if these were to be seen as color at all, and thus injured his perception of more delicate color harmonies ; so that in innumerable instances it becomes very disputable whether monuments even of the best times were improved by the color bestowed upon them, or the contrary. But, in the South, the flatness and comparatively vague forms of the sculpture, while they appeared to call for color in order to enhance their interest, presented exactly the conditions which would set it off to the greatest advantage ; breadth of surface displaying even the most delicate tints in the lights, and faintness of shadow joining with the most delicate and pearly greys of color harmony ; while the subject of the design being in nearly all cases reduced to mere intricacy of ornamental line, might be colored in any way the architect chose without any loss of rationality. Where oak-leaves and roses were carved into fresh relief and perfect bloom, it was necessary to paint the one green and the other red ; but in portions of ornamentation where there was nothing which could be definitely construed into either an oak-leaf or a rose, but a mere labyrinth of beautiful lines, becoming here something like a leaf, and there something like a flower, the whole tracery of the sculpture might be left white, and grounded with gold or blue, or treated in any other manner best harmonizing with

the colors around it. And as the necessarily feeble character of the sculpture called for and was ready to display the best arrangements of color, so the precious marbles in the architect's hands give him at once the best examples and the best means of color. The best examples, for the tints of all natural stones are as exquisite in quality as endless in change; and the best means, for they are all permanent.

§ XLVI. Every motive thus concurred in urging him to the study of chromatic decoration, and every advantage was given him in the pursuit of it; and this at the very moment when, as presently to be noticed, the *naïveté* of barbaric Christianity could only be forcibly appealed to by the help of colored pictures: so that, both externally and internally, the architectural construction became partly merged in pictorial effect; and the whole edifice is to be regarded less as a temple wherein to pray, than as itself a Book of Common Prayer, a vast illuminated missal, bound with alabaster instead of parchment, studded with porphyry pillars instead of jewels, and written within and without in letters of enamel and gold.

§ XLVII. LAW VII. *That the impression of the architecture is not to be dependent on size.* And now there is but one final consequence to be deduced. The reader understands, I trust, by this time, that the claims of these several parts of the building upon his attention will depend upon their delicacy of design, their perfection of color, their preciousness of material, and their legendary interest. All these qualities are independent of size, and partly even inconsistent with it. Neither delicacy of surface sculpture, nor subtle gradations of color, can be appreciated by the eye at a distance; and since we have seen that our sculpture is generally to be only an inch or two in depth, and that our coloring is in great part to be produced with the soft tints and veins of natural stones, it will follow necessarily that none of the parts of the building can be removed far from the eye, and therefore that the whole mass of it cannot be large. It is not even desirable that it should be so; for the temper in which the mind addresses itself to contemplate minute and beautiful details is altogether different from that in which it submits itself to vague impressions of

space and size. And therefore we must not be disappointed, but grateful, when we find all the best work of the building concentrated within a space comparatively small ; and that, for the great cliff-like buttresses and mighty piers of the North, shooting up into indiscernible height, we have here low walls spread before us like the pages of a book, and shafts whose capitals we may touch with our hand.

§ XLVIII. The due consideration of the principles above stated will enable the traveller to judge with more candor and justice of the architecture of St. Mark's than usually it would have been possible for him to do while under the influence of the prejudices necessitated by familiarity with the very different schools of Northern art. I wish it were in my power to lay also before the general reader some exemplification of the manner in which these strange principles are developed in the lovely building. But exactly in proportion to the nobility of any work, is the difficulty of conveying a just impression of it ; and wherever I have occasion to bestow high praise, there it is exactly most dangerous for me to endeavor to illustrate my meaning, except by reference to the work itself. And, in fact, the principal reason why architectural criticism is at this day so far behind all other, is the impossibility of illustrating the best architecture faithfully. Of the various schools of painting, examples are accessible to every one, and reference to the works themselves is found sufficient for all purposes of criticism ; but there is nothing like St. Mark's or the Ducal Palace to be referred to in the National Gallery, and no faithful illustration of them is possible on the scale of such a volume as this. And it is exceedingly difficult on any scale. Nothing is so rare in art, as far as my own experience goes, as a fair illustration of architecture ; *perfect* illustration of it does not exist. For all good architecture depends upon the adaptation of its chiselling to the effect at a certain distance from the eye ; and to render the peculiar confusion in the midst of order, and uncertainty in the midst of decision, and mystery in the midst of trenchant lines, which are the result of distance, together with perfect expression of the peculiarities of the design, requires the skill of the most admirable

artist, devoted to the work with the most severe conscientiousness, neither the skill nor the determination having as yet been given to the subject. And in the illustration of details, every building of any pretensions to high architectural rank would require a volume of plates, and those finished with extraordinary care. With respect to the two buildings which are the principal subjects of the present volume, St. Mark's and the Ducal Palace, I have found it quite impossible to do them the slightest justice by any kind of portraiture; and I abandoned the endeavor in the case of the latter with less regret, because in the new Crystal Palace (as the poetical public insist upon calling it, though it is neither a palace, nor of crystal) there will be placed, I believe, a noble cast of one of its angles. As for St. Mark's, the effort was hopeless from the beginning. For its effect depends not only upon the most delicate sculpture in every part, but, as we have just stated, eminently on its color also, and that the most subtle, variable, inexpressible color in the world,—the color of glass, of transparent alabaster, of polished marble, and lustrous gold. It would be easier to illustrate a crest of Scottish mountain, with its purple heather and pale harebells at their fullest and fairest, or a glade of Jura forest, with its floor of anemone and moss, than a single portico of St. Mark's. The fragment of one of its archivolts, given at the bottom of the opposite Plate, is not to illustrate the thing itself, but to illustrate the impossibility of illustration.

§ XLIX. It is left a fragment, in order to get it on a larger scale; and yet even on this scale it is too small to show the sharp folds and points of the marble vine-leaves with sufficient clearness. The ground of it is gold, the sculpture in the spandrils is not more than an inch and a half deep, rarely so much. It is in fact nothing more than an exquisite sketching of outlines in marble, to about the same depth as in the Elgin frieze; the draperies, however, being filled with close folds, in the manner of the Byzantine pictures, folds especially necessary here, as large masses could not be expressed in the shallow sculpture without becoming insipid; but the disposition of these folds is always most beautiful, and often opposed



PLATE VI.—THE VINE. FREE, AND IN SERVICE.

by broad and simple spaces, like that obtained by the scroll in the hand of the prophet, seen in the plate.

The balls in the archivolt project considerably, and the interstices between their interwoven bands of marble are filled with colors like the illuminations of a manuscript; violet, crimson, blue, gold, and green alternately: but no green is ever used without an intermixture of blue pieces in the mosaic, nor any blue without a little centre of pale green; sometimes only a single piece of glass a quarter of an inch square, so subtle was the feeling for color which was thus to be satisfied.* The intermediate circles have golden stars set on an azure ground, varied in the same manner; and the small crosses seen in the intervals are alternately blue and subdued scarlet, with two small circles of white set in the golden ground above and beneath them, each only about half an inch across (this work, remember, being on the outside of the building, and twenty feet above the eye), while the blue crosses have each a pale green centre. Of all this exquisitely mingled hue, no plate, however large or expensive, could give any adequate conception; but, if the reader will supply in imagination to the engraving what he supplies to a common woodcut of a group of flowers, the decision of the respective merits of modern and of Byzantine architecture may be allowed to rest on this fragment of St. Mark's alone.

From the vine-leaves of that archivolt, though there is no direct imitation of nature in them, but on the contrary a studious subjection to architectural purpose more particularly to be noticed hereafter, we may yet receive the same kind of pleasure which we have in seeing true vine-leaves and wreathed branches traced upon golden light; its stars upon their azure ground ought to make us remember, as its builder remembered, the stars that ascend and fall in the great arch of the sky: and I believe that stars, and boughs, and leaves, and bright colors are everlastingly lovely, and to be by all

* The fact is, that no two tesserae of the glass are exactly of the same tint, the greens being all varied with blues, the blues of different depths, the reds of different clearness, so that the effect of each mass of color is full of variety, like the stippled color of a fruit piece.

men beloved ; and, moreover, that church walls grimly seared with squared lines, are not better nor nobler things than these. I believe the man who designed and the men who delighted in that archivolt to have been wise, happy, and holy. Let the reader look back to the archivolt I have already given out of the streets of London (Plate XIII. Vol. I.), and see what there is in it to make us any of the three. Let him remember that the men who design such work as that call St. Mark's a barbaric monstrosity, and let him judge between us.

§ L. Some farther details of the St. Mark's architecture, and especially a general account of Byzantine capitals, and of the principal ones at the angles of the church, will be found in the following chapter.* Here I must pass on to the second part of our immediate subject, namely, the inquiry how far the exquisite and varied ornament of St. Mark's fits it, as a Temple, for its sacred purpose, and would be applicable in the churches of modern times. We have here evidently two questions : the first, that wide and continually agitated one, whether richness of ornament be right in churches at all ; the second, whether the ornament of St. Mark's be of a truly ecclesiastical and Christian character.

§ LI. In the first chapter of the "Seven Lamps of Architecture" I endeavored to lay before the reader some reasons why churches ought to be richly adorned, as being the only places in which the desire of offering a portion of all precious things to God could be legitimately expressed. But I left wholly untouched the question : whether the church, as such, stood in need of adornment, or would be better fitted for its purposes by possessing it. This question I would now ask the reader to deal with briefly and candidly.

The chief difficulty in deciding it has arisen from its being always presented to us in an unfair form. It is asked of us, or we ask of ourselves, whether the sensation which we now feel in passing from our own modern dwelling-house, through a newly built street, into a cathedral of the thirteenth century,

* Some illustration, also, of what was said in § XXXIII. above, respecting the value of the shafts of St. Mark's as large jewels, will be found in Appendix 9, "Shafts of St. Mark's."

be safe or desirable as a preparation for public worship. But we never ask whether that sensation was at all calculated upon by the builders of the cathedral.

§ LII. Now I do not say that the contrast of the ancient with the modern building, and the strangeness with which the earlier architectural forms fall upon the eye, are at this day disadvantageous. But I do say, that their effect, whatever it may be, was entirely uncalculated upon by the old builder. He endeavored to make his work beautiful, but never expected it to be strange. And we incapacitate ourselves altogether from fair judgment of its intention, if we forget that, when it was built, it rose in the midst of other work fanciful and beautiful as itself; that every dwelling-house in the middle ages was rich with the same ornaments and quaint with the same grotesques which fretted the porches or animated the gargoyles of the cathedral; that what we now regard with doubt and wonder, as well as with delight, was then the natural continuation, into the principal edifice of the city, of a style which was familiar to every eye throughout all its lanes and streets; and that the architect had often no more idea of producing a peculiarly devotional impression by the richest color and the most elaborate carving, than the builder of a modern meeting-house has by his white-washed walls and square-cut casements.*

§ LIII. Let the reader fix this great fact well in his mind, and then follow out its important corollaries. We attach, in modern days, a kind of sacredness to the pointed arch and the groined roof, because, while we look habitually out of square windows and live under flat ceilings, we meet with the more beautiful forms in the ruins of our abbeys. But when those abbeys were built, the pointed arch was used for every shop door, as well as for that of the cloister, and the feudal baron and freebooter feasted, as the monk sang, under vaulted roofs; not because the vaulting was thought especially appropriate to either the revel or psalm, but because it was then the form in which a strong roof was easiest built. We have destroyed the goodly architecture of our cities; we have substituted one

* See the farther notice of this subject in Vol. III. Chap. IV.

wholly devoid of beauty or meaning; and then we reason respecting the strange effect upon our minds of the fragments which, fortunately, we have left in our churches, as if those churches had always been designed to stand out in strong relief from all the buildings around them, and Gothic architecture had always been, what it is now, a religious language, like Monkish Latin. Most readers know, if they would arouse their knowledge, that this was not so; but they take no pains to reason the matter out: they abandon themselves drowsily to the impression that Gothic is a peculiarly ecclesiastical style; and sometimes, even, that richness in church ornament is a condition or furtherance of the Romish religion. Undoubtedly it has become so in modern times: for there being no beauty in our recent architecture, and much in the remains of the past, and these remains being almost exclusively ecclesiastical, the High Church and Romanist parties have not been slow in availing themselves of the natural instincts which were deprived of all food except from this source; and have willingly promulgated the theory, that because all the good architecture that is now left is expressive of High Church or Romanist doctrines, all good architecture ever has been and must be so,—a piece of absurdity from which, though here and there a country clergyman may innocently believe it, I hope the common sense of the nation will soon manfully quit itself. It needs but little inquiry into the spirit of the past, to ascertain what, once for all, I would desire here clearly and forcibly to assert, that wherever Christian church architecture has been good and lovely, it has been merely the perfect development of the common dwelling-house architecture of the period; that when the pointed arch was used in the street, it was used in the church; when the round arch was used in the street, it was used in the church; when the pinnacle was set over the garret window, it was set over the belfry tower; when the flat roof was used for the drawing-room, it was used for the nave. There is no sacredness in round arches, nor in pointed; none in pinnacles, nor in buttresses; none in pillars, nor in traceries. Churches were larger than most other buildings, because they had to hold more people; they were

more adorned than most other buildings, because they were safer from violence, and were the fitting subjects of devotional offering : but they were never built in any separate, mystical, and religious style ; they were built in the manner that was common and familiar to everybody at the time. The flamboyant traceries that adorn the façade of Rouen Cathedral had once their fellows in every window of every house in the market-place ; the sculptures that adorn the porches of St. Mark's had once their match on the walls of every palace on the Grand Canal ; and the only difference between the church and the dwelling-house was, that there existed a symbolical meaning in the distribution of the parts of all buildings meant for worship, and that the painting or sculpture was, in the one case, less frequently of profane subject than in the other. A more severe distinction cannot be drawn : for secular history was constantly introduced into church architecture ; and sacred history or allusion generally formed at least one half of the ornament of the dwelling-house.

§ LIV. This fact is so important, and so little considered, that I must be pardoned for dwelling upon it at some length, and accurately marking the limits of the assertion I have made. I do not mean that every dwelling-house of mediæval cities was as richly adorned and as exquisite in composition as the fronts of their cathedrals, but that they presented features of the same kind, often in parts quite as beautiful ; and that the churches were not separated by any change of style from the buildings round them, as they are now, but were merely more finished and full examples of a universal style, rising out of the confused streets of the city as an oak tree does out of an oak copse, not differing in leafage, but in size and symmetry. Of course the quaint and smaller forms of turret and window necessary for domestic service, the inferior materials, often wood instead of stone, and the fancy of the inhabitants, which had free play in the design, introduced oddnesses, vulgarities, and variations into house architecture, which were prevented by the traditions, the wealth, and the skill of the monks and freemasons ; while, on the other hand, conditions of vaulting, buttressing, and arch and tower build-

ing, were necessitated by the mere size of the cathedral, of which it would be difficult to find examples elsewhere. But there was nothing more in these features than the adaptation of mechanical skill to vaster requirements ; there was nothing intended to be, or felt to be, especially ecclesiastical in any of the forms so developed ; and the inhabitants of every village and city, when they furnished funds for the decoration of their church, desired merely to adorn the house of God as they adorned their own, only a little more richly, and with a somewhat graver temper in the subjects of the carving. Even this last difference is not always clearly discernible : all manner of ribaldry occurs in the details of the ecclesiastical buildings of the North, and at the time when the best of them were built, every man's house was a kind of temple ; a figure of the Madonna, or of Christ, almost always occupied a niche over the principal door, and the Old Testament histories were curiously interpolated amidst the grotesques of the brackets and the gables.

§ LV. And the reader will now perceive that the question respecting fitness of church decoration rests in reality on totally different grounds from those commonly made foundations of argument. So long as our streets are walled with barren brick, and our eyes rest continually, in our daily life, on objects utterly ugly, or of inconsistent and meaningless design, it may be a doubtful question whether the faculties of eye and mind which are capable of perceiving beauty, having been left without food during the whole of our active life, should be suddenly feasted upon entering a place of worship ; and color, and music, and sculpture should delight the senses, and stir the curiosity of men unaccustomed to such appeal, at the moment when they are required to compose themselves for acts of devotion ;—this, I say, may be a doubtful question : but it cannot be a question at all, that if once familiarized with beautiful form and color, and accustomed to see in whatever human hands have executed for us, even for the lowest services, evidence of noble thought and admirable skill, we shall desire to see this evidence also in whatever is built or labored for the house of prayer ; that the absence of the ac-

customed loveliness would disturb instead of assisting devotion ; and that we should feel it as vain to ask whether, with our own house full of goodly craftsmanship, we should worship God in a house destitute of it, as to ask whether a pilgrim whose day's journey had led him through fair woods and by sweet waters, must at evening turn aside into some barren place to pray.

§ LVI. Then the second question submitted to us, whether the ornament of St. Mark's be truly ecclesiastical and Christian, is evidently determined together with the first ; for, if not only the permission of ornament at all, but the beautiful execution of it, be dependent on our being familiar with it in daily life, it will follow that no style of noble architecture *can* be exclusively ecclesiastical. It must be practised in the dwelling before it be perfected in the church, and it is the test of a noble style that it shall be applicable to both ; for if essentially false and ignoble, it may be made to fit the dwelling-house, but never can be made to fit the church : and just as there are many principles which will bear the light of the world's opinion, yet will not bear the light of God's word, while all principles which will bear the test of Scripture will also bear that of practice, so in architecture there are many forms which expediency and convenience may apparently justify, or at least render enduring, in daily use, which will yet be found offensive the moment they are used for church service ; but there are none good for church service, which cannot bear daily use. Thus the Renaissance manner of building is a convenient style for dwelling-houses, but the natural sense of all religious men causes them to turn from it with pain when it has been used in churches ; and this has given rise to the popular idea that the Roman style is good for houses and the Gothic for churches. This is not so ; the Roman style is essentially base, and we can bear with it only so long as it gives us convenient windows and spacious rooms ; the moment the question of convenience is set aside, and the expression or beauty of the style is tried by its being used in a church, we find it fail. But because the Gothic and Byzantine styles are fit for churches they are not therefore less fit for dwellings.

They are in the highest sense fit and good for both, nor were they ever brought to perfection except where they were used for both.

§ LVII. But there is one character of Byzantine work which, according to the time at which it was employed, may be considered as either fitting or unfitting it for distinctly ecclesiastical purposes ; I mean the essentially pictorial character of its decoration. We have already seen what large surfaces it leaves void of bold architectural features, to be rendered interesting merely by surface ornament or sculpture. In this respect Byzantine work differs essentially from pure Gothic styles, which are capable of filling every vacant space by features purely architectural, and may be rendered, if we please, altogether independent of pictorial aid. A Gothic church may be rendered impressive by mere successions of arches, accumulations of niches, and entanglements of tracery. But a Byzantine church requires expression and interesting decoration over vast plane surfaces,—decoration which becomes noble only by becoming pictorial ; that is to say, by representing natural objects,—men, animals, or flowers. And, therefore, the question whether the Byzantine style be fit for church service in modern days, becomes involved in the inquiry, what effect upon religion has been or may yet be produced by pictorial art, and especially by the art of the mosaicist ?

§ LVIII. The more I have examined the subject the more dangerous I have found it to dogmatize respecting the character of the art which is likely, at a given period, to be most useful to the cause of religion. One great fact first meets me. I cannot answer for the experience of others, but I never yet met with a Christian whose heart was thoroughly set upon the world to come, and, so far as human judgment could pronounce, perfect and right before God, who cared about art at all. I have known several very noble Christian men who loved it intensely, but in them there was always traceable some entanglement of the thoughts with the matters of this world, causing them to fall into strange distresses and doubts, and often leading them into what they themselves would confess to be errors in understanding, or even failures in duty. I do not

say that these men may not, many of them, be in very deed nobler than those whose conduct is more consistent; they may be more tender in the tone of all their feelings, and farther-sighted in soul, and for that very reason exposed to greater trials and fears, than those whose hardier frame and naturally narrower vision enable them with less effort to give their hands to God and walk with Him. But still, the general fact is indeed so, that I have never known a man who seemed altogether right and calm in faith, who seriously cared about art; and when casually moved by it, it is quite impossible to say beforehand by what class of art this impression will on such men be made. Very often it is by a theatrical commonplace, more frequently still by false sentiment. I believe that the four painters who have had, and still have, the most influence, such as it is, on the ordinary Protestant Christian mind, are Carlo Dolci, Guercino, Benjamin West, and John Martin. Raphael, much as he is talked about, is, I believe in very fact, rarely looked at by religious people; much less his master, or any of the truly great religious men of old. But a smooth Magdalen of Carlo Dolci with a tear on each cheek, or a Guercino Christ or St. John, or a Scripture illustration of West's, or a black cloud with a flash of lightning in it of Martin's, rarely fails of being verily, often deeply, felt for the time.

§ LIX. There are indeed many very evident reasons for this; the chief one being that, as all truly great religious painters have been hearty Romanists, there are none of their works which do not embody, in some portions of them, definitely Romanist doctrines. The Protestant mind is instantly struck by these, and offended by them, so as to be incapable of entering, or at least rendered indisposed to enter, farther into the heart of the work, or to the discovering those deeper characters of it, which are not Romanist, but Christian, in the everlasting sense and power of Christianity. Thus most Protestants, entering for the first time a Paradise of Angelico, would be irrevocably offended by finding that the first person the painter wished them to speak to was St. Dominic; and would retire from such a heaven as speedily as possible,—not giving themselves time to discover, that whether dressed in black, or

white, or grey, and by whatever name in the calendar they might be called, the figures that filled that Angelico heaven were indeed more saintly, and pure, and full of love in every feature, than any that the human hand ever traced before or since. And thus Protestantism, having foolishly sought for the little help it requires at the hand of painting from the men who embodied no Catholic doctrine, has been reduced to receive it from those who believed neither Catholicism nor Protestantism, but who read the Bible in search of the picturesque. We thus refuse to regard the painters who passed their lives in prayer, but are perfectly ready to be taught by those who spent them in debauchery. There is perhaps no more popular Protestant picture than Salvator's "Witch of Endor," of which the subject was chosen by the painter simply because, under the names of Saul and the Sorceress, he could paint a captain of banditti, and a Neapolitan hag.

§ LX. The fact seems to be that strength of religious feeling is capable of supplying for itself whatever is wanting in the rudest suggestions of art, and will either, on the one hand, purify what is coarse into inoffensiveness, or, on the other, raise what is feeble into impressiveness. Probably all art, as such, is unsatisfactory to it; and the effort which it makes to supply the void will be induced rather by association and accident than by the real merit of the work submitted to it. The likeness to a beloved friend, the correspondence with a habitual conception, the freedom from any strange or offensive particularity, and, above all, an interesting choice of incident, will win admiration for a picture when the noblest efforts of religious imagination would otherwise fail of power. How much more, when to the quick capacity of emotion is joined a childish trust that the picture does indeed represent a fact! It matters little whether the fact be well or ill told; the moment we believe the picture to be true, we complain little of its being ill-painted. Let it be considered for a moment, whether the child, with its colored print, inquiring eagerly and gravely which is Joseph, and which is Benjamin, is not more capable of receiving a strong, even a sublime, impression from the rude symbol which it invests with reality by its own

effort, than the connoisseur who admires the grouping of the three figures in Raphael's "Telling of the Dreams;" and whether also, when the human mind is in right religious tone, it has not always this childish power—I speak advisedly, this power—a noble one, and possessed more in youth than at any period of after life, but always, I think, restored in a measure by religion—of raising into sublimity and reality the rudest symbol which is given to it of accredited truth.

§ LXI. Ever since the period of the Renaissance, however, the truth has not been accredited; the painter of religious subject is no longer regarded as the narrator of a fact, but as the inventor of an idea.* We do not severely criticise the manner in which a true history is told, but we become harsh investigators of the faults of an invention; so that in the modern religious mind, the capacity of emotion, which renders judgment uncertain, is joined with an incredulity which renders it severe; and this ignorant emotion, joined with ignorant observance of faults, is the worst possible temper in which any art can be regarded, but more especially sacred art. For as religious faith renders emotion facile, so also it generally renders expression simple; that is to say a truly religious painter will very often be ruder, quainter, simpler, and more faulty in his manner of working, than a great irreligious one. And it was in this artless utterance, and simple acceptance, on the part of both the workman and the beholder, that all noble schools of art have been cradled; it is in them that they *must* be cradled to the end of time. It is impossible to calculate

* I do not mean that modern Christians believe less in the *facts* than ancient Christians, but they do not believe in the representation of the facts as true. We look upon the picture as this or that painter's conception; the elder Christians looked upon it as this or that painter's description of what had actually taken place. And in the Greek Church all painting is, to this day, strictly a branch of tradition. See M. Didron's admirably written introduction to his *Iconographie Chrétienne*, p. 7:—"Un de mes compagnons s'étonnait de retrouver à la Panagia de St. Luc, le saint Jean Chrysostome qu'il avait dessiné dans le baptistère de St. Marc, à Venise. Le costume des personnages est partout et en tout temps le même, non-seulement pour la forme, mais pour la couleur, mais pour le dessin, mais jusque pour le nombre et l'épaisseur des plis."

the enormous loss of power in modern days, owing to the imperative requirement that art shall be methodical and learned : for as long as the constitution of this world remains unaltered, there will be more intellect in it than there can be education : there will be many men capable of just sensation and vivid invention, who never will have time to cultivate or polish their natural powers. And all unpolished power is in the present state of society lost ; in other things as well as in the arts, but in the arts especially : nay, in nine cases out of ten, people mistake the polish for the power. Until a man has passed through a course of academy studentship, and can draw in an approved manner with French chalk, and knows foreshortening, and perspective, and something of anatomy, we do not think he can possibly be an artist ; what is worse, we are very apt to think that we can *make* him an artist by teaching him anatomy, and how to draw with French chalk ; whereas the real gift in him is utterly independent of all such accomplishments : and I believe there are many peasants on every estate, and laborers in every town, of Europe, who have imaginative powers of a high order, which nevertheless cannot be used for our good, because we do not choose to look at anything but what is expressed in a legal and scientific way. I believe there is many a village mason who, set to carve a series of Scripture or any other histories, would find many a strange and noble fancy in his head, and set it down, roughly enough indeed, but in a way well worth our having. But we are too grand to let him do this, or to set up his clumsy work when it is done ; and accordingly the poor stone-mason is kept hewing stones smooth at the corners, and we build our church of the smooth square stones, and consider ourselves wise.

§ LXII. I shall pursue this subject farther in another place ; but I allude to it here in order to meet the objections of those persons who suppose the mosaics of St. Mark's, and others of the period, to be utterly barbarous as representations of religious history. Let it be granted that they are so ; we are not for that reason to suppose they were ineffective in religious teaching. I have above spoken of the whole church as a great Book of Common Prayer ; the mosaics were its illuminations.

and the common people of the time were taught their Scripture history by means of them, more impressively perhaps, though far less fully, than ours are now by Scripture reading. They had no other Bible, and—Protestants do not often enough consider this—*could* have no other. We find it somewhat difficult to furnish our poor with printed Bibles; consider what the difficulty must have been when they could be given only in manuscript. The walls of the church necessarily became the poor man's Bible, and a picture was more easily read upon the walls than a chapter. Under this view, and considering them merely as the Bible pictures of a great nation in its youth, I shall finally invite the reader to examine the connexion and subjects of these mosaics; but in the meantime I have to deprecate the idea of their execution being in any sense barbarous. I have conceded too much to modern prejudice, in permitting them to be rated as mere childish efforts at colored portraiture: they have characters in them of a very noble kind; nor are they by any means devoid of the remains of the science of the later Roman empire. The character of the features is almost always fine, the expression stern and quiet, and very solemn, the attitudes and draperies always majestic in the single figures, and in those of the groups which are not in violent action; * while the bright coloring and disregard of chiaroscuro cannot be regarded as imperfections, since they are the only means by which the figures could be rendered clearly intelligible in the distance and darkness of the vaulting. So far am I from considering them barbarous, that I believe of all works of religious art whatsoever, these, and such as these, have been the most effective. They stand exactly midway between the debased manufacture of wooden and waxen images which is the support of Romanist idolatry all

* All the effects of Byzantine art to represent violent action are inadequate, most of them ludicrously so, even when the sculptural art is in other respects far advanced. The early Gothic sculptors, on the other hand, fail in all points of refinement, but hardly ever in expression of action. This distinction is of course one of the necessary consequences of the difference in all respects between the repose of the Eastern, and activity of the Western, mind, which we shall have to trace out completely in the inquiry into the nature of Gothic.

over the world, and the great art which leads the mind away from the religious subject to the art itself. Respecting neither of these branches of human skill is there, nor can there be, any question. The manufacture of puppets, however influential on the Romanist mind of Europe, is certainly not deserving of consideration as one of the fine arts. It matters literally nothing to a Romanist what the image he worships is like. Take the vilest doll that is screwed together in a cheap toy-shop, trust it to the keeping of a large family of children, let it be beaten about the house by them till it is reduced to a shapeless block, then dress it in a satin frock and declare it to have fallen from heaven, and it will satisfactorily answer all Romanist purposes. Idolatry,* it cannot be too often repeated, is no encourager of the fine arts. But, on the other hand, the highest branches of the fine arts are no encouragers either of idolatry or of religion. No picture of Leonardo's or Raphael's, no statue of Michael Angelo's, has ever been worshipped, except by accident. Carelessly regarded, and by ignorant persons, there is less to attract in them than in commoner works. Carefully regarded, and by intelligent persons, they instantly divert the mind from their subject to their art, so that admiration takes the place of devotion. I do not say that the Madonna di S. Sisto, the Madonna del Cardellino, and such others, have not had considerable religious influence on certain minds, but I say that on the mass of the people of Europe they have had none whatever; while by far the greater number of the most celebrated statues and pictures are never regarded with any other feelings than those of admiration of human beauty, or reverence for human skill. Effective religious art, therefore, has always lain, and I believe must always lie, between the two extremes—of barbarous idol-fashioning on one side, and magnificent craftsmanship on the other. It consists partly in missal painting, and such book-illustrations as, since the invention of printing, have taken its place; partly in glass-painting; partly in rude sculpture on the outsides of buildings; partly in mosaics; and partly in the frescoes and tempera pictures

* Appendix 10, "Proper Sense of the word Idolatry."

which, in the fourteenth century, formed the link between this powerful, because imperfect, religious art, and the impotent perfection which succeeded it.

§ LXIII. But of all these branches the most important are the inlaying and mosaic of the twelfth and thirteenth centuries, represented in a central manner by these mosaics of St. Mark's. Missal-painting could not, from its minuteness, produce the same sublime impressions, and frequently merged itself in mere ornamentation of the page. Modern book-illustration has been so little skilful as hardly to be worth naming. Sculpture, though in some positions it becomes of great importance, has always a tendency to lose itself in architectural effect; and was probably seldom deciphered, in all its parts, by the common people, still less the traditions annealed in the purple burning of the painted window. Finally, tempera pictures and frescoes were often of limited size or of feeble color. But the great mosaics of the twelfth and thirteenth centuries covered the walls and roofs of the churches with inevitable lustre; they could not be ignored or escaped from; their size rendered them majestic, their distance mysterious, their color attractive. They did not pass into confused or inferior decorations; neither were they adorned with any evidences of skill or science, such as might withdraw the attention from their subjects. They were before the eyes of the devotee at every interval of his worship; vast shadowings forth of scenes to whose realization he looked forward, or of spirits whose presence he invoked. And the man must be little capable of receiving a religious impression of any kind, who, to this day, does not acknowledge some feeling of awe, as he looks up at the pale countenances and ghastly forms which haunt the dark roofs of the Baptisteries of Parma and Florence, or remains altogether untouched by the majesty of the colossal images of apostles, and of Him who sent apostles, that look down from the darkening gold of the domes of Venice and Pisa.

§ LXIV. I shall, in a future portion of this work, endeavor to discover what probabilities there are of our being able to use this kind of art in modern churches; but at present it remains for us to follow out the connexion of the subjects rep-

resented in St. Mark's so as to fulfil our immediate object, and form an adequate conception of the feelings of its builders, and of its uses to those for whom it was built.

Now there is one circumstance to which I must, in the outset, direct the reader's special attention, as forming a notable distinction between ancient and modern days. Our eyes are now familiar and wearied with writing; and if an inscription is put upon a building, unless it be large and clear, it is ten to one whether we ever trouble ourselves to decipher it. But the old architect was sure of readers. He knew that every one would be glad to decipher all that he wrote; that they would rejoice in possessing the vaulted leaves of his stone manuscript; and that the more he gave them, the more grateful would the people be. We must take some pains, therefore, when we enter St. Mark's, to read all that is inscribed, or we shall not penetrate into the feeling either of the builder or of his times.

§ LXV. A large atrium or portico is attached to two sides of the church, a space which was especially reserved for unbaptized persons and new converts. It was thought right that, before their baptism, these persons should be led to contemplate the great facts of the Old Testament history; the history of the Fall of Man, and of the lives of Patriarchs up to the period of the Covenant by Moses: the order of the subjects in this series being very nearly the same as in many Northern churches, but significantly closing with the Fall of the Manna, in order to mark to the catechumen the insufficiency of the Mosaic covenant for salvation,—“Our fathers did eat manna in the wilderness, and are dead,”—and to turn his thoughts to the true Bread of which that manna was the type.

§ LXVI. Then, when after his baptism he was permitted to enter the church, over its main entrance he saw, on looking back, a mosaic of Christ enthroned, with the Virgin on one side and St. Mark on the other, in attitudes of adoration. Christ is represented as holding a book open upon his knee, on which is written: “I AM THE DOOR; BY ME IF ANY MAN ENTER IN, HE SHALL BE SAVED.” On the red marble moulding which sur-

rounds the mosaic is written : "I AM THE GATE OF LIFE ; LET THOSE WHO ARE MINE ENTER BY ME." Above, on the red marble fillet which forms the cornice of the west end of the church, is written, with reference to the figure of Christ below : " WHO HE WAS, AND FROM WHOM HE CAME, AND AT WHAT PRICE HE REDEEMED THEE, AND WHY HE MADE THEE, AND GAVE THEE ALL THINGS, DO THOU CONSIDER."

Now observe, this was not to be seen and read only by the catechumen when he first entered the church ; every one who at any time entered, was supposed to look back and to read this writing ; their daily entrance into the church was thus made a daily memorial of their first entrance into the spiritual Church ; and we shall find that the rest of the book which was opened for them upon its walls continually led them in the same manner to regard the visible temple as in every part a type of the invisible Church of God.

§ LXVII. Therefore the mosaic of the first dome, which is over the head of the spectator as soon as he has entered by the great door (that door being the type of baptism), represents the effusion of the Holy Spirit, as the first consequence and seal of the entrance into the Church of God. In the centre of the cupola is the Dove, enthroned in the Greek manner, as the Lamb is enthroned, when the Divinity of the Second and Third Persons is to be insisted upon together with their peculiar offices. From the central symbol of the Holy Spirit twelve streams of fire descend upon the heads of the twelve apostles, who are represented standing around the dome ; and below them, between the windows which are pierced in its walls, are represented, by groups of two figures for each separate people, the various nations who heard the apostles speak, at Pentecost, every man in his own tongue. Finally, on the vaults, at the four angles which support the cupola, are pictured four angels, each bearing a tablet upon the end of a rod in his hand : on each of the tablets of the three first angels is inscribed the word " Holy ;" on that of the fourth is written " Lord ;" and the beginning of the hymn being thus put into the mouths of the four angels, the words of it are continued around the border of the dome, uniting

praise to God for the gift of the Spirit, with welcome to the redeemed soul received into His Church :

“ HOLY, HOLY, HOLY, LORD GOD OF SABAOth :
HEAVEN AND EARTH ARE FULL OF THY GLORY.

HOSANNA IN THE HIGHEST :

BLESSED IS HE THAT COMETH IN THE NAME OF THE LORD.”

And observe in this writing that the convert is required to regard the outpouring of the Holy Spirit especially as a work of *sanctification*. It is the *holiness* of God manifested in the giving of His Spirit to sanctify those who had become His children, which the four angels celebrate in their ceaseless praise ; and it is on account of this holiness that the heaven and earth are said to be full of His glory.

§ LXVIII. After thus hearing praise rendered to God by the angels for the salvation of the newly-entered soul, it was thought fittest that the worshipper should be led to contemplate, in the most comprehensive forms possible, the past evidence and the future hopes of Christianity, as summed up in three facts without assurance of which all faith is vain ; namely that Christ died, that He rose again, and that He ascended into heaven, there to prepare a place for His elect. On the vault between the first and second cupolas are represented the crucifixion and resurrection of Christ, with the usual series of intermediate scenes,—the treason of Judas, the judgment of Pilate, the crowning with thorns, the descent into Hades, the visit of the women to the sepulchre, and the apparition to Mary Magdalene. The second cupola itself, which is the central and principal one of the church, is entirely occupied by the subject of the Ascension. At the highest point of it Christ is represented as rising into the blue heaven, borne up by four angels, and throned upon a rainbow, the type of reconciliation. Beneath him, the twelve apostles are seen upon the Mount of Olives, with the Madonna, and, in the midst of them, the two men in white apparel who appeared at the moment of the Ascension, above whom, as uttered by them, are inscribed the words, “ Ye men of Galilee, why stand ye

gazing up into heaven? This Christ, the Son of God, as He is taken from you, shall so come, the arbiter of the earth, trusted to do judgment and justice."

§ LXXIX. Beneath the circle of the apostles, between the windows of the cupola, are represented the Christian virtues, as sequent upon the crucifixion of the flesh, and the spiritual ascension together with Christ. Beneath them, on the vaults which support the angles of the cupola, are placed the four Evangelists, because on their evidence our assurance of the fact of the ascension rests; and, finally, beneath their feet, as symbols of the sweetness and fulness of the Gospel which they declared, are represented the four rivers of Paradise, Pison, Gihon, Tigris, and Euphrates.

§ LXX. The third cupola, that over the altar, represents the witness of the Old Testament to Christ; showing him enthroned in its centre, and surrounded by the patriarchs and prophets. But this dome was little seen by the people;* their contemplation was intended to be chiefly drawn to that of the centre of the church, and thus the mind of the worshipper was at once fixed on the main groundwork and hope of Christianity,—“Christ is risen,” and “Christ shall come.” If he had time to explore the minor lateral chapels and cupolas, he could find in them the whole series of New Testament history, the events of the Life of Christ, and the Apostolic miracles in their order, and finally the scenery of the Book of Revelation; † but if he only entered, as often the common people do to this hour, snatching a few moments before beginning the labor of the day to offer up an ejaculatory prayer, and advanced but from the main entrance as far as the altar screen, all the splendor of the glittering nave and variegated dome, if they smote upon his heart, as they might often, in strange contrast with his reed cabin among the shallows of the lagoon, smote upon it only that they might proclaim the two great messages—“Christ is risen,” and “Christ shall

* It is also of inferior workmanship, and perhaps later than the rest. Vide Lord Lindsay, vol. i. p. 124, note.

† The old mosaics from the Revelation have perished, and have been replaced by miserable work of the seventeenth century.

come." Daily, as the white cupolas rose like wreaths of sea-foam in the dawn, while the shadowy campanile and frowning palace were still withdrawn into the night, they rose with the Easter Voice of Triumph,—“Christ is risen;” and daily, as they looked down upon the tumult of the people, deepening and eddying in the wide square that opened from their feet to the sea, they uttered above them the sentence of warning,—“Christ shall come.”

§ LXXI. And this thought may surely dispose the reader to look with some change of temper upon the gorgeous building and wild blazonry of that shrine of St. Mark's. He now perceives that it was in the hearts of the old Venetian people far more than a place of worship. It was at once a type of the Redeemed Church of God, and a scroll for the written word of God. It was to be to them, both an image of the Bride, all glorious within, her clothing of wrought gold; and the actual Table of the Law and the Testimony, written within and without. And whether honored as the Church or as the Bible, was it not fitting that neither the gold nor the crystal should be spared in the adornment of it; that, as the symbol of the Bride, the building of the wall thereof should be of jasper,* and the foundations of it garnished with all manner of precious stones; and that, as the channel of the World, that triumphant utterance of the Psalmist should be true of it,—“I have rejoiced in the way of thy testimonies, as much as in all riches?” And shall we not look with changed temper down the long perspective of St. Mark's Place towards the sevenfold domes and glowing domes of its temple, when we know with solemn purpose the shafts of it were lifted above the pavement of a populous square? Men met there from all countries of the earth, for traffic or for pleasure; but, above the tumult for ever to and fro in the restlessness of avarice, there was seen perpetually the glory of the Redeemed Church, whether they would hear or whether they would not. There was one treasure which they sought without a price, and one delight which they sought above the law and the statutes of God.

Not in the wantonness of wealth, not in vain ministry to the desire of the eyes or the pride of life, were those marbles hewn into transparent strength, and those arches arrayed in the colors of the iris. There is a message written in the dyes of them, that once was written in blood; and a sound in the echoes of their vaults, that one day shall fill the vault of heaven, —“ He shall return, to do judgment and justice.” The strength of Venice was given her, so long as she remembered this: her destruction found her when she had forgotten this; and it found her irrevocably, because she forgot it without excuse. Never had city a more glorious Bible. Among the nations of the North, a rude and shadowy sculpture filled their temples with confused and hardly legible imagery; but, for her, the skill and the treasures of the East had gilded every letter, and illumined every page, till the Book-Temple shone from afar off like the star of the Magi. In other cities, the meetings of the people were often in places withdrawn from religious association, subject to violence and to change; and on the grass of the dangerous rampart, and in the dust of the troubled street, there were deeds done and counsels taken, which, if we cannot justify, we may sometimes forgive. But the sins of Venice, whether in her palace or in her piazza, were done with the Bible at her right hand. The walls on which its testimony was written were separated but by a few inches of marble from those which guarded the secrets of her councils, or confined the victims of her policy. And when in her last hours she threw off all shame and all restraint, and the great square of the city became filled with the madness of the whole earth, be it remembered how much her sin was greater, because it was done in the face of the House of God, burning with the letters of His Law. Mountebank and masquer laughed their laugh, and went their way; and a silence has followed them, not unforecast; for amidst them all, through century after century of gathering vanity and festering guilt, that white dome of St. Mark's had uttered in the dead ear of Venice, “Know thou, that for all these things God will bring thee into judgment.”

CHAPTER V.

BYZANTINE PALACES.

§ I. THE account of the architecture of St. Mark's given in the previous chapter has, I trust, acquainted the reader sufficiently with the spirit of the Byzantine style: but he has probably, as yet, no clear idea of its generic forms. Nor would it be safe to define these after an examination of St. Mark's alone, built as it was upon various models, and at various periods. But if we pass through the city, looking for buildings which resemble St. Mark's—first, in the most important feature of incrustation; secondly, in the character of the mouldings,—we shall find a considerable number, not indeed very attractive in their first address to the eye, but agreeing perfectly, both with each other, and with the earliest portions of St. Mark's, in every important detail; and to be regarded, therefore, with profound interest, as indeed the remains of an ancient city of Venice, altogether different in aspect from that which now exists. From these remains we may with safety deduce general conclusions touching the forms of Byzantine architecture, as practised in Eastern Italy, during the eleventh, twelfth, and thirteenth centuries.

§ II. They agree in another respect, as well as in style. All are either ruins, or fragments disguised by restoration. Not one of them is uninjured or unaltered; and the impossibility of finding so much as an angle or a single story in perfect condition is a proof, hardly less convincing than the method of their architecture, that they were indeed raised during the earliest phases of the Venetian power. The mere fragments, dispersed in narrow streets, and recognizable by a single capital, or the segment of an arch, I shall not enumerate: but, or important remains, there are six in the immediate neighborhood of the Rialto, one in the Rio di Ca' Foscari, and one conspicuously placed opposite the great Renaissance Palace known as the Vendramin Calerghi, one of the few palaces still inhabited * and well maintained; and noticeable, moreover, as hav-

* In the year 1851, by the Duchesse de Berri.

ing a garden beside it, rich with evergreens, and decorated by gilded railings and white statues that cast long streams of snowy reflection down into the deep water. The vista of canal beyond is terminated by the Church of St. Geremia, another but less attractive work of the Renaissance ; a mass of barren brickwork, with a dull leaden dome above, like those of our National Gallery. So that the spectator has the richest and meanest of the late architecture of Venice before him at once : the richest, let him observe, a piece of private luxury ; the poorest, that which was given to God. Then, looking to the left, he will see the fragment of the work of earlier ages, testifying against both, not less by its utter desolation than by the nobleness of the traces that are still left of it.

§ III. It is a ghastly ruin ; whatever is venerable or sad in its wreck being disguised by attempts to put it to present uses of the basest kind. It has been composed of arcades borne by marble shafts, and walls of brick faced with marble : but the covering stones have been torn away from it like the shroud from a corpse ; and its walls, rent into a thousand chasms, are filled and refilled with fresh brickwork, and the seams and hollows are choked with clay and whitewash, oozing and trickling over the marble,—itself blanched into dusty decay by the frosts of centuries. Soft grass and wandering leafage have rooted themselves in the rents, but they are not suffered to grow in their own wild and gentle way, for the place is in a sort inhabited ; rotten partitions are nailed across its corridors, and miserable rooms contrived in its western wing ; and here and there the weeds are indolently torn down, leaving their haggard fibres to struggle again into unwholesome growth when the spring next stirs them : and thus, in contest between death and life, the unsightly heap is festering to its fall.

Of its history little is recorded, and that little futile. That it once belonged to the dukes of Ferrara, and was bought from them in the sixteenth century, to be made a general receptacle for the goods of the Turkish merchants, whence it is now generally known as the *Fondaco*, or *Fontico*, *de' Turchi*, are facts just as important to the antiquary, as that, in the year 1852,

the municipality of Venice allowed its lower story to be used for a "deposito di Tabacchi." Neither of this, nor of any other remains of the period, can we know anything but what their own stones will tell us.

§ iv. The reader will find in Appendix 11, written chiefly for the traveller's benefit, an account of the situation and present state of the other seven Byzantine palaces. Here I shall only give a general account of the most interesting points in their architecture.

They all agree in being round-arched and incrusting with marble, but there are only six in which the original disposition of the parts is anywise traceable; namely, those distinguished in the Appendix as the Fondaco de' Turchi, Casa Loredan, Casa Farsetti, Rio-Foscari House, Terraced House, and Madonnetta House: * and these six agree farther in having continuous arcades along their entire fronts from one angle to the other, and in having their arcades divided, in each case, into a centre and wings; both by greater size in the midmost arches, and by the alternation of shafts in the centre, with pilasters, or with small shafts, at the flanks.

§ v. So far as their structure can be traced, they agree also in having tall and few arches in their lower stories, and shorter and more numerous arches above: but it happens most unfortunately that in the only two cases in which the second stories are left the ground floors are modernized, and in the others where the sea stories are left the second stories are modernized; so that we never have more than two tiers of the Byzantine arches, one above the other. These, however, are quite enough to show the first main point on which I wish to insist, namely, the subtlety of the feeling for proportion in the Greek architects; and I hope that even the general reader will not allow himself to be frightened by the look of a few measurements, for, if he will only take the little pains necessary to compare them, he will, I am almost certain, find the result not devoid of interest.

§ vi. I had intended originally to give elevations of all

* Of the Braided House and Casa Businello, described in the Appendix, only the great central arcades remain.

these palaces ; but have not had time to prepare plates requiring so much labor and care. I must, therefore, explain the position of their parts in the simplest way in my power.

The Fondaco de' Turchi has sixteen arches in its sea story, and twenty-six above them in its first story, the whole based on a magnificent foundation, built of blocks of red marble, some of them seven feet long by a foot and a half thick, and raised to a height of about five feet above high-water mark.

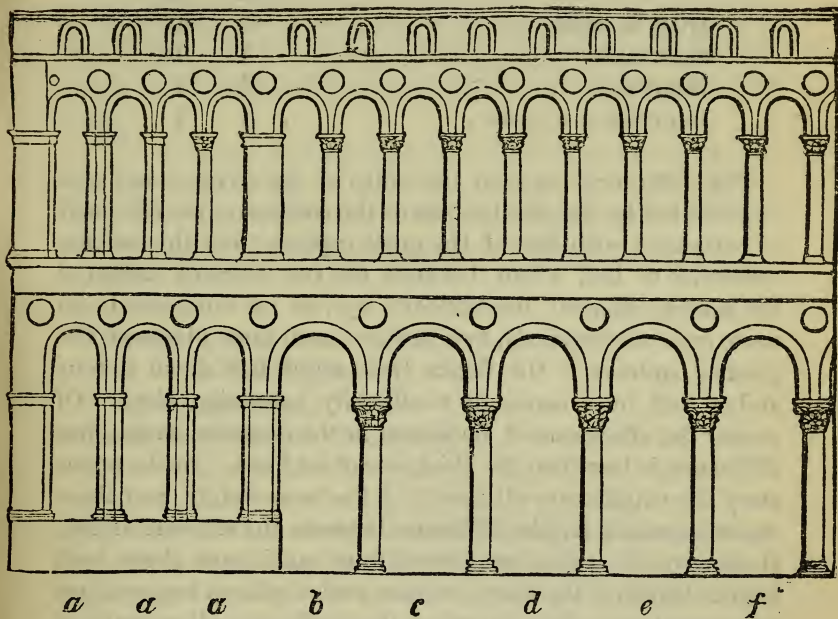

FIG. IV.

At this level, the elevation of one half of the building, from its flank to the central pillars of its arcades, is rudely given in Fig. IV. It is only drawn to show the arrangement of the parts, as the sculptures which are indicated by the circles and upright oblongs between the arches are too delicate to be shown in a sketch three times the size of this. The building once was crowned with an Arabian parapet ; but it was taken down some years since, and I am aware of no authentic rep-

resentation of its details. The greater part of the sculptures between the arches, indicated in the woodcut only by blank circles, have also fallen, or been removed, but enough remain on the two flanks to justify the representation given in the diagram of their original arrangement.

And now observe the dimensions. The small arches of the wings in the ground story, *a, a, a*, measure, in breadth, from

			Ft.	In.
shaft to shaft	.	.	4	5
interval <i>b</i>	.	.	7	6½
interval <i>c</i>	.	.	7	11
intervals <i>d, e, f, &c.</i>	.	.	8	1

The difference between the width of the arches *b* and *c* is necessitated by the small recess of the cornice on the left hand as compared with that of the great capitals; but this sudden difference of half a foot between the two extreme arches of the centre offended the builder's eye, so he diminished the next one, *unnecessarily*, two inches, and thus obtained the gradual cadence to the flanks, from eight feet down to four and a half, in a series of continually increasing steps. Of course the effect cannot be shown in the diagram, as the first difference is less than the thickness of its lines. In the upper story the capitals are all nearly of the same height, and there was no occasion for the difference between the extreme arches. Its twenty-six arches are placed, four small ones above each lateral three of the lower arcade, and eighteen larger above the central ten; thus throwing the shafts into all manner of relative positions, and completely confusing the eye in any effort to count them: but there is an exquisite symmetry running through their apparent confusion; for it will be seen that the four arches in each flank are arranged in two groups, of which one has a large single shaft in the centre, and the other a pilaster and two small shafts. The way in which the large shaft is used as an echo of those in the central arcade, dovetailing them, as it were, into the system of the pilasters,—just as a great painter, passing from one tone of color to

another, repeats, over a small space, that which he has left,— is highly characteristic of the Byzantine care in composition. There are other evidences of it in the arrangement of the capitals, which will be noticed below in the seventh chapter. The lateral arches of this upper arcade measure 3 ft. 2 in. across, and the central 3 ft. 11 in., so that the arches in the building are altogether of six magnitudes.

§ VII. Next let us take the Casa Loredan. The mode of arrangement of its pillars is precisely like that of the Fondaco de' Turchi, so that I shall merely indicate them by vertical lines in order to be able to letter the intervals. It has five arches in the centre of the lower story, and two in each of its wings.

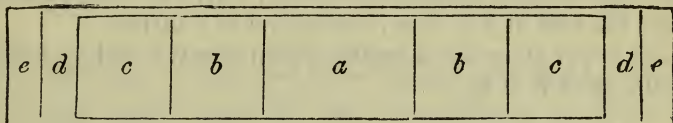

	Ft.	In.
The midmost interval, <i>a</i> , of the central five, is	6	1
The two on each side, <i>b, b</i>	5	2
The two extremes, <i>c, c</i>	4	9
Inner arches of the wings, <i>d, d</i>	4	4
Outer arches of the wings, <i>e, e</i>	4	6

The gradation of these dimensions is visible at a glance : the boldest step being here taken nearest the centre, while in the Fondaco it is farthest from the centre. The first loss here is of eleven inches, the second of five, the third of five, and then there is a most subtle increase of two inches in the extreme arches, as if to contradict the principle of diminution, and stop the falling away of the building by firm resistance at its flanks.

I could not get the measures of the upper story accurately, the palace having been closed all the time I was in Venice ; but it has seven central arches above the five below, and three at the flanks above the two below, the groups being separated by double shafts.

§ VIII. Again, in the Casa Farsetti, the lower story has a centre of five arches, and wings of two. Referring, therefore, to the last figure, which will answer for this palace also, the measures of the intervals are :

	Ft.	In.
<i>a</i>	8	0
<i>b</i>	5	10
<i>c</i>	5	4
<i>d</i> and <i>e</i>	5	3

It is, however, possible that the interval *c* and the wing arches may have been intended to be similar ; for one of the wing arches measures 5 ft. 4 in. We have thus a simpler proportion than any we have hitherto met with ; only two losses taking place, the first of 2 ft. 2 in., the second of 6 inches.

The upper story has a central group of seven arches, whose widths are 4 ft. 1 in.

	Ft.	In.
The next arch on each side	3	5
The three arches of each wing	3	6

Here again we have a most curious instance of the subtlety of eye which was not satisfied without a third dimension, but *could* be satisfied with a difference of an inch on three feet and a half.

§ IX. In the Terraced House, the ground floor is modernized, but the first story is composed of a centre of five arches, with wings of two, measuring as follows :

	Ft.	In.
Three midmost arches of the central group	4	0
Outermost arch of the central group	4	6
Innermost arch of the wing	4	10
Outermost arch of the wing *	5	0

Here the greatest step is towards the centre ; but the increase, which is unusual, is towards the outside, the gain being successively six, four, and two inches.

I could not obtain the measures of the second story, in

* Only one wing of the first story is left. See Appendix 11.

which only the central group is left ; but the two outermost arches are visibly larger than the others, thus beginning a correspondent proportion to the one below, of which the lateral quantities have been destroyed by restorations.

§ x. Finally, in the Rio-Foscari House, the central arch is the principal feature, and the four lateral ones form one magnificent wing ; the dimensions being from the centre to the side :

				Ft.	In.
Central arch	.	.	.	9	9
Second "	.	.	.	3	8
Third "	.	.	.	3	10
Fourth "	.	.	.	3	10
Fifth "	.	.	.	3	8

The difference of two inches on nearly three feet in the two midmost arches being all that was necessary to satisfy the builder's eye.

§ xi. I need not point out to the reader that these singular and minute harmonies of proportion indicate, beyond all dispute, not only that the buildings in which they are found are of one school, but (so far as these subtle coincidences of measurement can still be traced in them) in their original form. No modern builder has any idea of connecting his arches in this manner, and restorations in Venice are carried on with too violent hands to admit of the supposition that such refinements would be even noticed in the progress of demolition, much less imitated in heedless reproduction. And as if to direct our attention especially to this character, as indicative of Byzantine workmanship, the most interesting example of all will be found in the arches of the front of St. Mark's itself, whose proportions I have not noticed before, in order that they might here be compared with those of the contemporary palaces.

§ xii. The doors actually employed for entrance in the western façade are as usual five, arranged as at *a* in the annexed woodcut, Fig.V. ; but the Byzantine builder could not be satisfied with so simple a group, and he introduced, therefore,

two minor arches at the extremities, as at *b*, by adding two small porticos which are of *no use whatever* except to consummate the proportions of the façade, and themselves to exhibit

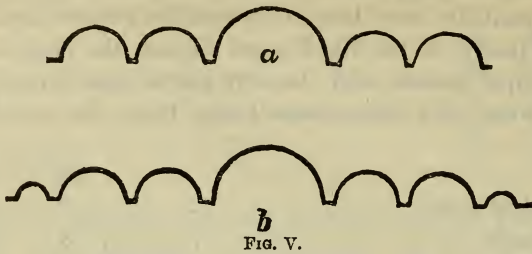

FIG. V.

the most exquisite proportions in arrangements of shaft and archivolt with which I am acquainted in the entire range of European architecture.

Into these minor particulars I cannot here enter ; but observe the dimensions of the range of arches in the façade, as thus completed by the flanking porticos :

	Ft.	In.
The space of its central archivolt is	31	8
“ the two on each side, about *	19	8
“ the two succeeding, about	20	4
“ small arches at flanks, about	6	0

I need not make any comment upon the subtle difference of eight inches on twenty feet between the second and third dimensions. If the reader will be at the pains to compare the whole evidence now laid before him, with that deduced above from the apse of Murano, he cannot but confess that it amounts to an irrefragable proof of an intense perception of harmony in the relation of quantities, on the part of the By-

* I am obliged to give these measures approximately, because, this front having been studied by the builder with unusual care, not one of its measures is the same as another ; and the symmetries between the correspondent arches are obtained by changes in the depth of their mouldings and variations in their heights, far too complicated for me to enter into here ; so that of the two arches stated as 19 ft. 8 in. in span, one is in reality 19 ft. 6½ in., the other 19 ft. 10 in., and of the two stated as 20 ft. 4 in., one is 20 ft. and the other 20 ft. 8 in.

zantine architects; a perception which we have at present lost so utterly as hardly to be able even to conceive it. And let it not be said, as it was of the late discoveries of subtle curvature in the Parthenon,* that what is not to be demonstrated without laborious measurement, cannot have influence on the beauty of the design. The eye is continually influenced by what it cannot detect; nay, it is not going too far to say, that it is most influenced by what it detects least. Let the painter define, if he can, the variations of lines on which depend the changes of expression in the human countenance. The greater he is, the more he will feel their subtlety, and the intense difficulty of perceiving all their relations, or answering for the consequences of a variation of a hair's breadth in a single curve. Indeed, there is nothing truly noble either in color or in form, but its power depends on circumstances infinitely too intricate to be explained, and almost too subtle to be traced. And as for these Byzantine buildings, we only do not feel them because we do not *watch* them; otherwise we should as much enjoy the variety of proportion in their arches, as we do at present that of the natural architecture of flowers and leaves.

Any of us can feel in an instant the grace of the leaf group, *b*, in the annexed figure; and yet that grace is simply owing to its being proportioned like the façade of St. Mark's; each leaflet answering to an arch,—the smallest at the root, to those of the porticos. I

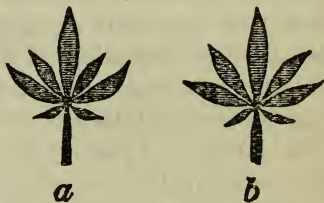

FIG. VI.

have tried to give the proportion quite accurately in *b*; but as the difference between the second and third leaflets is hardly discernible on so small a scale, it is somewhat exaggerated in *a*. † Nature is often far more subtle in her proportions. In looking at some of the nobler species of lilies, full the front of the flower, we may fancy for a moment that

* By Mr. Penrose.

† I am sometimes obliged, unfortunately, to read my woodcuts backwards owing to my having forgotten to reverse them on the wood.

they form a symmetrical six-petaled star; but on examining them more closely, we shall find that they are thrown into a group of three magnitudes by the expansion of two of the inner petals above the stamens to a breadth greater than any of the four others; while the third inner petal, on which the stamens rest, contracts itself into the narrowest of the six, and the three under petals remain of one intermediate magnitude, as seen in the annexed figure.



FIG. VII.

§ XIII. I must not, however, weary the reader with this subject, which has always been a favorite one with me, and is apt to lead too far; we will return to the palaces on the Grand Canal. Admitting, then, that their fragments are proved, by the minute correspondence of their arrangement, to be still in their original positions, they indicate to us a form, whether of palace or dwelling-house, in which there were, universally, central galleries, or loggias, opening into apartments on each wing, the amount of light admitted being immense; and the general proportions of the building, slender, light, and graceful in the utmost degree, it being in fact little more than an aggregate of shafts and arches. Of the interior disposition of these palaces there is in no instance the slightest trace left, nor am I well enough acquainted with the existing architecture of the East to risk any conjecture on this subject. I pursue the statement of the facts which still are ascertainable respecting their external forms.

§ XIV. In every one of the buildings above mentioned, except the Rio-Foscari House (which has only one great entrance between its wings), the central arcades are sustained, at least in one story, and generally in both, on bold detached cylindrical shafts, with rich capitals, while the arches of the wings are carried on smaller shafts assisted by portions of wall, which become pilasters of greater or less width.

And now I must remind the reader of what was pointed out above (Vol. I. Chap. XXVII. §§ III. xxxv. xl.), that there are two great orders of capitals in the world; that one of these is convex in its contour, the other concave; and that

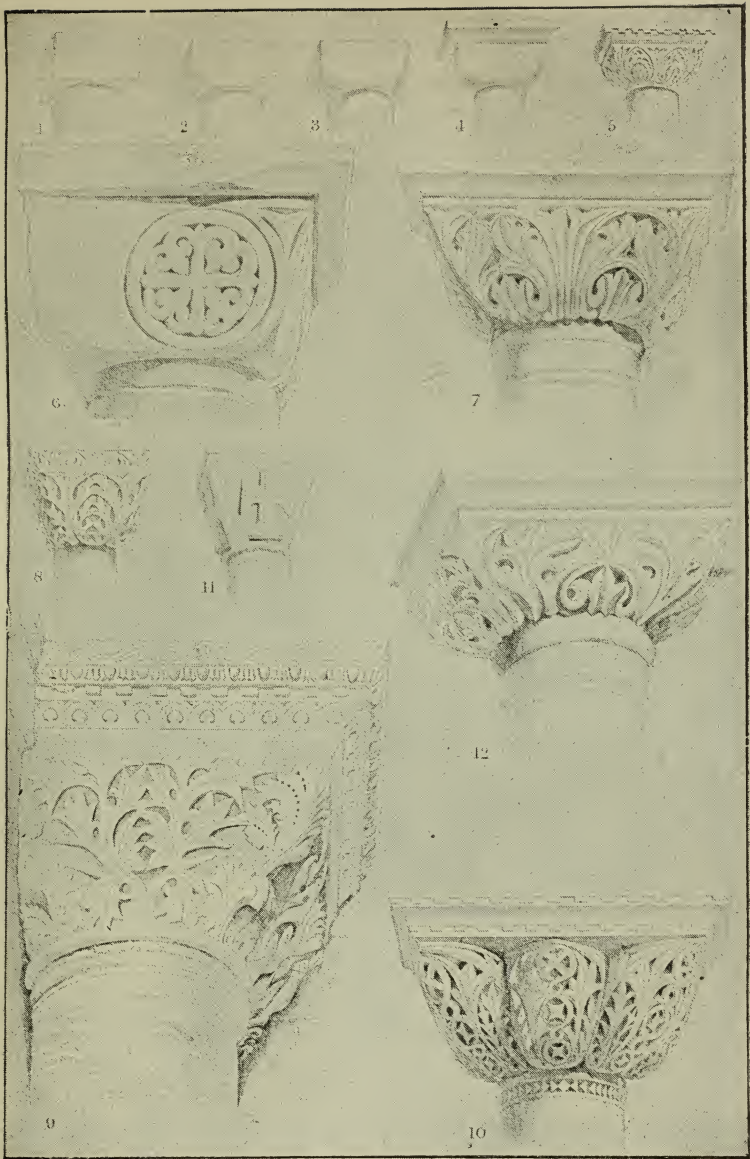

PLATE VII.—BYZANTINE CAPITALS. CONVEX GROUP.

richness of ornament, with all freedom of fancy, is for the most part found in the one, and severity of ornament, with stern discipline of the fancy, in the other.

Of these two families of capitals both occur in the Byzantine period, but the concave group is the longest-lived, and extends itself into the Gothic times. In the account which I gave of them in the first volume, they were illustrated by giving two portions of a simple curve, that of a salvia leaf. We must now investigate their characters more in detail; and these may be best generally represented by considering both families as formed upon the types of flowers,—the one upon that of the water-lily, the other upon that of the convolvulus. There was no intention in the Byzantine architects to imitate either one or the other of these flowers; but, as I have already so often repeated, all beautiful works of art must either intentionally imitate or accidentally resemble natural forms; and the direct comparison with the natural forms which these capitals most resemble, is the likeliest mode of fixing their distinctions in the reader's mind.

The one then, the convex family, is modelled according to the commonest shapes of that great group of flowers which form rounded cups, like that of the water-lily, the leaves springing horizontally from the stalk, and closing together upwards. The rose is of this family, but her cup is filled with the luxuriance of her leaves; the crocus, campanula, ranunculus, anemone, and almost all the loveliest children of the field, are formed upon the same type.

The other family resembles the convolvulus, trumpet-flower, and such others, in which the lower part of the bell is slender, and the lip curves outwards at the top. There are fewer flowers constructed on this than on the convex model; but in the organization of trees and of clusters of herbage it is seen continually. Of course, both of these conditions are modified, when applied to capitals, by the enormously greater thickness of the stalk or shaft, but in other respects the parallelism is close and accurate; and the reader had better at once fix the flower outlines in his mind,* and remember

* Vide Plate X. figs. 1 and 4.

them as representing the only two orders of capitals that the world has ever seen, or can see.

§ xv. The examples of the concave family in the Byzantine times are found principally either in large capitals founded on the Greek Corinthian, used chiefly for the nave pillars of churches, or in the small lateral shafts of the palaces. It appears somewhat singular that the pure Corinthian form should have been reserved almost exclusively for nave pillars, as at Torcello, Murano, and St. Mark's; it occurs, indeed, together with almost every other form, on the exterior of St. Mark's also, but never so definitely as in the nave and transept shafts. Of the conditions assumed by it at Torcello enough has been said; and one of the most delicate of the varieties occurring in St. Mark's is given in Plate VIII., fig. 15, remarkable for the cutting of the sharp thistle-like leaves into open relief, so that the light sometimes shines through them from behind, and for the beautiful curling of the extremities of the leaves outwards, joining each other at the top, as in an undivided flower.

§ xvi. The other characteristic examples of the concave groups in the Byzantine times are as simple as those resulting from the Corinthian are rich. They occur on the *small* shafts at the flanks of the Fondaco de' Turchi, the Casa Farsetti, Casa Loredan, Terraced House, and upper story of the Madonnetta House, in forms so exactly similar that the two figures 1 and 2 in Plate VIII. may sufficiently represent them all. They consist merely of portions cut out of the plinths or string-courses which run along all the faces of these palaces, by four truncations in the form of arrowy leaves (fig. 1, Fondaco de' Turchi), and the whole rounded a little at the bottom so as to fit the shaft. When they occur between two arches they assume the form of the group fig. 2 (Terraced House). Fig. 3 is from the central arches of the Casa Farsetti, and is only given because either it is a later restoration or a form absolutely unique in the Byzantine period.

§ xvii. The concave group, however, was not naturally pleasing to the Byzantine mind. Its own favorite capital was of the bold convex or cushion shape, so conspicuous in all the

buildings of the period that I have devoted Plate VII., opposite entirely to its illustration. The form in which it is first used is practically obtained from a square block laid on the head of the shaft (fig. 1, Plate VII.), by first cutting off the lower corners, as in fig. 2, and then rounding the edges, as in fig. 3; this gives us the bell stone: on this is laid a simple abacus, as seen in fig. 4, which is the actual form used in the upper arcade of Murano, and the framework of the capital is complete. Fig. 5 shows the general manner and effect of its decoration on the same scale; the other figures, 6 and 7, both from the apse of Murano, 8, from the Terraced House, and 9, from the Baptistery of St. Mark's, show the method of chiselling the surfaces in capitals of average richness, such as occur everywhere, for there is no limit to the fantasy and beauty of the more elaborate examples.

§ XVIII. In consequence of the peculiar affection entertained for these massy forms by the Byzantines, they were apt, when they used any condition of capital founded on the Corinthian, to modify the concave profile by making it bulge out at the bottom. Fig. 1, *a*, Plate X., is the profile of a capital of the pure concave family; and observe, it needs a fillet or cord round the neck of the capital to show where it separates from the shaft. Fig. 4, *a*, on the other hand, is the profile of the pure convex group, which not only needs no such projecting fillet, but would be encumbered by it; while fig. 2, *a*, is the profile of one of the Byzantine capitals (Fondaco de' Turchi, lower arcade) founded on Corinthian, of which the main sweep is concave, but which bends below into the convex bell-shape, where it joins the shaft. And, lastly, fig. 3, *a*, is the profile of the nave shafts of St. Mark's, where, though very delicately granted, the concession to the Byzantine temper is twofold; first at the spring of the curve from the base, and secondly the top, where it again becomes convex, though the expression of the Corinthian bell is still given to it by the bold concave leaves.

§ XIX. These, then, being the general modifications of Byzantine profiles, I have thrown together in Plate VIII., opposite, some of the most characteristic examples of the decora-

tion of the concave and transitional types ; their localities are given in the note below,* and the following are the principal points to be observed respecting them.

The purest concave forms, 1 and 2, were never decorated in the earliest times, except sometimes by an incision or rib down the centre of their truncations on the angles.

Figures 4, 5, 6, and 7 show some of the modes of application of a peculiarly broad-lobed acanthus leaf, very characteristic of native Venetian work ; 4 and 5 are from the same building, two out of a group of four, and show the boldness of the variety admitted in the management even of the capitals most closely derived from the Corinthian. I never saw one of these Venetian capitals in all respects like another. The trefoils into which the leaves fall at the extremities are, however, for the most part similar, though variously disposed, and generally niche themselves one under the other, as very characteristically in fig. 7. The form 8 occurs in St. Mark's only, and there very frequently : 9 at Venice occurs, I think, in St. Mark's only ; but it is a favorite early Lombardic form. 10, 11, and 12 are all highly characteristic. 10 occurs with more fantastic interweaving upon its sides in the upper stories of St. Mark's ; 11 is derived, in the Casa Loredan, from the great lily capitals of St. Mark's, of which more presently. 13 and 15 are peculiar to St. Mark's. 14 is a lovely condition, occurring both there and in the Fondaco de' Turchi.

The modes in which the separate portions of the leaves are executed in these and other Byzantine capitals, will be noticed more at length hereafter. Here I only wish the reader to observe two things, both with respect to these and the capitals of

- | | |
|--|---------------------------------------|
| * 1. Fondaco de' Turchi, lateral pillars. | 8. St. Mark's. |
| 2. Terraced House, lateral pillars. | 9. St. Mark's. |
| 3. Casa Farsetti, central pillars, upper arcade. | 10. Braided House, upper arcade. |
| 4. Casa Loredan, lower arcade. | 11. Casa Loredan, upper arcade. |
| 5. Casa Loredan, lower arcade. | 12. St. Mark's. |
| 6. Fondaco de' Turchi, upper arcade. | 13. St. Mark's. |
| 7. Casa Loredan, upper arcade. | 14. Fondaco de' Turchi, upper arcade. |
| | 15. St. Mark's. |

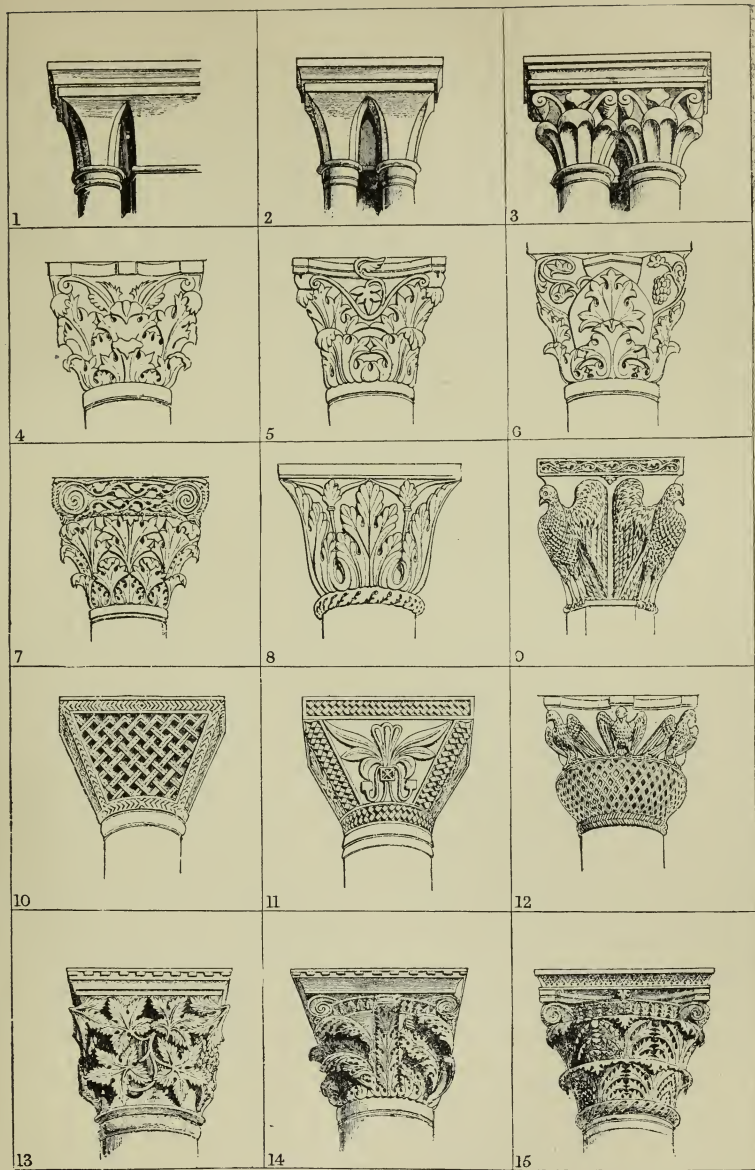

PLATE VIII.—BYZANTINE CAPITALS. CONCAVE GROUP.

the convex family on the former Plate : first the Life, secondly, the Breadth, of these capitals, as compared with Greek forms.

§ xx. I say, first, the Life. Not only is every one of these capitals differently fancied, but there are many of them which *have no two sides alike*. Fig. 5, for instance, varies on every side in the arrangement of the pendent leaf in its centre ; fig. 6 has a different plant on each of its four upper angles. The birds are each cut with a different play of plumage in figs. 9 and 12, and the vine-leaves are every one varied in their position in fig. 13. But this is not all. The differences in the character of ornamentation between them and the Greek capitals, all show a greater love of nature ; the leaves are, every one of them, more founded on realities, sketched, however rudely, more directly from the truth ; and are continually treated in a manner which shows the mind of the workman to have been among the living herbage, not among Greek precedents. The hard outlines in which, for the sake of perfect intelligibility, I have left this Plate, have deprived the examples of the vitality of their light and shade ; but the reader can nevertheless observe the *ideas* of life occurring perpetually : at the top of fig. 4, for instance, the small leaves turned sideways ; in fig. 5, the formal volutes of the old Corinthian transformed into a branching tendril ; in fig. 6, the bunch of grapes thrown carelessly in at the right-hand corner, in defiance of all symmetry ; in fig. 7, the volutes knitted into wreaths of ivy ; in fig. 14, the leaves, drifted, as it were, by a whirlwind round the capital by which they rise ; while figs. 13 and 15 are as completely living leaves as any of the Gothic time. These designs may or may not be graceful ; what grace or beauty they have is not to be rendered in mere outline,—but they are indisputably more *natural* than any Greek ones, and therefore healthier, and tending to greatness.

§ XXI. In the second place, note in all these examples, the excessive breadth of the masses, however afterwards they may be filled with detail. Whether we examine the contour of the simple convex bells, or those of the leaves which bend outwards from the richer and more Corinthian types, we find they

are all outlined by grand and simple curves, and that the whole of their minute fretwork and thistle-work is cast into a gigantic mould which subdues all their multitudinous points and foldings to its own inevitable dominion. And the fact is, that in the sweeping lines and broad surfaces of these Byzantine sculptures we obtain, so far as I know, for the first time in the history of art, the germ of that unity of perfect ease in every separate part, with perfect subjection to an enclosing form or directing impulse, which was brought to its most intense expression in the compositions of the two men in whom the art of Italy consummated itself and expired—Tintoret and Michael Angelo.

I would not attach too much importance to the mere habit of working on the rounded surface of the stone, which is often as much the result of haste or rudeness as of the desire for breadth, though the result obtained is not the less beautiful. But in the capital from the Fondaco de' Turchi, fig. 6, it will be seen that while the sculptor had taken the utmost care to make his leaves free, graceful, and sharp in effect, he was dissatisfied with their separation, and could not rest until he had enclosed them with an unbroken line, like that of a pointed arch; and the same thing is done in many different ways in other capitals of the same building, and in many of St. Mark's: but one such instance would have been enough to prove, if the loveliness of the profiles themselves did not do so, that the sculptor understood and loved the laws of generalization; and that the feeling which bound his prickly leaves, as they waved or drifted round the ridges of his capital, into those broad masses of unbroken flow, was indeed one with that which made Michael Angelo encompass the principal figure in his Creation of Adam with the broad curve of its cloudy drapery. It may seem strange to assert any connexion between so great a conception and these rudely hewn fragments of ruined marble; but all the highest principles of art are as universal as they are majestic, and there is nothing too small to receive their influence. They rule at once the waves of the mountain outline, and the sinuosities of the minutest lichen that stains its shattered stones.

§ xxxii. We have not yet spoken of the three braided and chequered capitals, numbered 10, 11, and 12. They are representations of a group, with which many most interesting associations are connected. It was noticed in the last chapter, that the method of covering the exterior of buildings with thin pieces of marble was likely to lead to a system of lighting the interior by minute perforation. In order to obtain both light and air, without admitting any unbroken body of sunshine, in warm countries, it became a constant habit of the Arabian architects to pierce minute and starlike openings in slabs of stone ; and to employ the stones so pierced where the Gothic architects employ traceries. Internally, the form of stars assumed by the light as it entered * was, in itself, an exquisite decoration ; but, externally, it was felt necessary to add some slight ornament upon the surface of the perforated stone ; and it was soon found that, as the small perforations had a tendency to look scattered and spotty, the most effective treatment of the intermediate surfaces would be one which bound them together, and gave unity and repose to the pierced and disturbed stone : universally, therefore, those intermediate spaces were carved into the semblance of interwoven fillets, which alternately sank beneath and rose above each other as they met. This system of braided or woven ornament was not confined to the Arabs ; it is universally pleasing to the instinct of mankind. I believe that nearly all early ornamentation is full of it,—more especially, perhaps, Scandinavian and Anglo-Saxon ; and illuminated manuscripts depend upon it for their loveliest effects of intricate color, up to the close of the thirteenth century. There are several very interesting metaphysical reasons for this strange and unfailing delight, felt in a thing so simple. It is not often that any idea of utility has power to enhance the true impressions of beauty ; but it is possible that the enormous importance of the art of weaving to mankind may give some interest, if not actual attractiveness, to any type or image of the invention to which we owe, at once, our comfort and our pride. But the more profound reason lies in the innate love of mystery and unity ; in the joy

* Compare "Seven Lamps," chap. ii. § 22.

that the human mind has in contemplating any kind of maze or entanglement, so long as it can discern, through its confusion, any guiding clue or connecting plan : a pleasure increased and solemnized by some dim feeling of the setting forth, by such symbols, of the intricacy, and alternate rise and fall, subjection and supremacy, of human fortune ; the

“ Weave the warp, and weave the woof,”

of Fate and Time.

§ xxiii. But be this as it may, the fact is that we are never tired of contemplating this woven involution ; and that, in some degree, the sublime pleasure which we have in watching the branches of trees, the intertwining of the grass, and the tracery of the higher clouds, is owing to it, not less than that which we receive from the fine meshes of the robe, the braiding of the hair, and the various glittering of the linked net or wreathed chain. Byzantine ornamentation, like that of almost all nations in a state of progress, is full of this kind of work : but it occurs most conspicuously, though most simply, in the minute traceries which surround their most solid capitals ; sometimes merely in a reticulated veil, as in the tenth figure in the Plate, sometimes resembling a basket, on the edges of which are perched birds and other animals. The diamonded ornament in the eleventh figure is substituted for it in the Casa Loredan, and marks a somewhat later time and a tendency to the ordinary Gothic chequer ; but the capitals which show it most definitely are those already so often spoken of as the lily capitals of St. Mark's, of which the northern one is carefully drawn in Plate IX.

§ xxiv. These capitals, called barbarous by our architects, are without exception the most subtle pieces of composition in broad contour which I have ever met with in architecture. Their profile is given in the opposite Plate X. fig. 3, *b* ; the inner line in the figure being that of the stone behind the lily, the outer that of the external network, taken through the side of the capital ; while fig. 3, *c* is the outer profile at its angle ; and the reader will easily understand that the passing

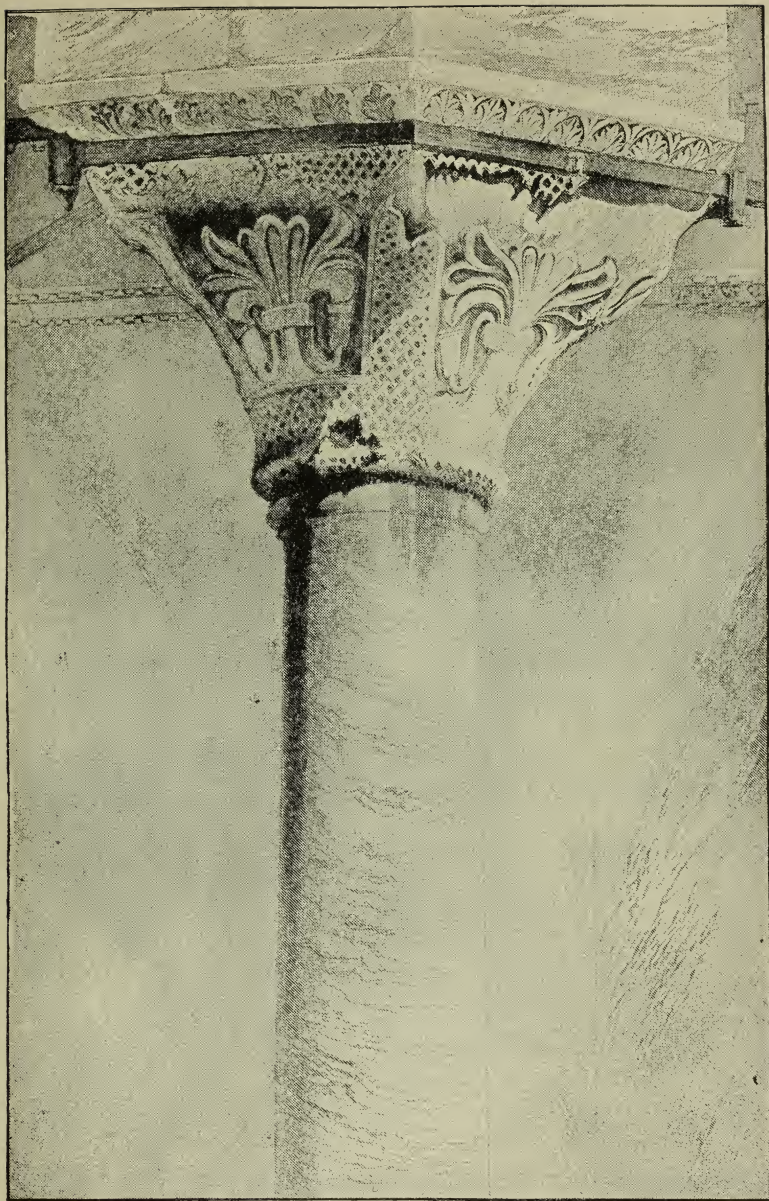

PLATE IX.—LILY CAPITAL OF ST. MARK'S.

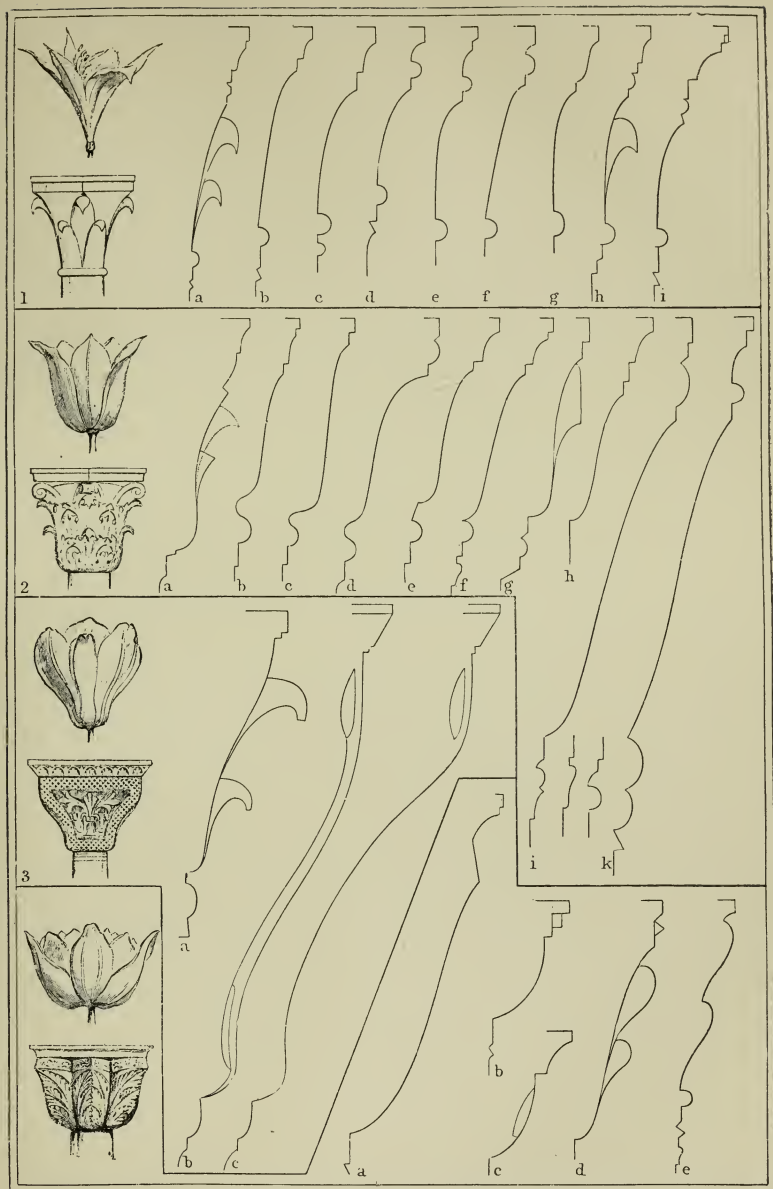

PLATE X.—FOUR VENETIAN FLOWER ORDERS.

of the one of these lines into the other is productive of the most exquisite and wonderful series of curvatures possible within such compass, no two views of the capital giving the same contour. Upon these profoundly studied outlines, as remarkable for their grace and complexity as the general mass of the capital is for solid strength and proportion to its necessary service, the braided work is wrought with more than usual care; perhaps, as suggested by the Marchese Selvatico, with some idea of imitating those "nets of chequerwork and wreaths of chainwork" on the chapiters of Solomon's temple, which are, I suppose, the first instances on record of an ornamentation of this kind thus applied. The braided work encloses on each of the four sides of the capital a flower whose form, derived from that of the lily, though as usual modified, in every instance of its occurrence, in some minor particulars, is generally seen as represented in fig. 11 of Plate VIII. It is never without the two square or oblong objects at the extremity of the tendrils issuing from its root, set like vessels to catch the dew from the points of its leaves; but I do not understand their meaning. The abacus of the capital has already been given at *a*, Plate XVI., Vol. I.; but no amount of illustrations or eulogium would be enough to make the reader understand the perfect beauty of the thing itself, as the sun steals from interstice to interstice of its marble veil, and touches with the white lustre of its rays at mid-day the pointed leaves of its thirsty lilies.

In all the capitals hitherto spoken of, the form of the head of the bell has been square, and its varieties of outline have been obtained in the transition from the square of the abacus to the circular outline of the shafts. A far more complex series of forms results from the division of the bell by recesses into separate lobes or leaves, like those of a rose or tulip, which are each in their turn covered with flowerwork or hollowed into reticulation. The example (fig. 10, Plate VII.) from St. Mark's will give some idea of the simplest of these conditions: perhaps the most exquisite in Venice, on the whole, is the central capital of the upper arcade of the Fondaco de' Turchi.

Such are the principal generic conditions of the Byzantine

capital ; but the reader must always remember that the examples given are single instances, and those not the most beautiful but the most intelligible, chosen out of thousands : the designs of the capitals of St. Mark's alone would form a volume.

§ xxv. Of the archivolt which these capitals generally sustain, details are given in the Appendix and in the notice of Venetian doors in Chapter VII. In the private palaces, the ranges of archivolt are for the most part very simple, with dentilled mouldings ; and all the ornamental effect is entrusted to pieces of sculpture set in the wall above or between the arches, in the manner shown in Plate XV., below, Chapter VII. These pieces of sculpture are either crosses, upright oblongs, or circles : of all the three forms an example is given in Plate XI. opposite. The cross was apparently an invariable ornament, placed either in the centre of the archivolt of the doorway, or in the centre of the first story above the windows ; on each side of it the circular and oblong ornaments were used in various alternation. In too many instances the wall marbles have been torn away from the earliest Byzantine palaces, so that the crosses are left on their archivolt only. The best examples of the cross set above the windows are found in houses of the transitional period : one in the Campo St^a M. Formosa ; another, in which a cross is placed between every window, is still well preserved in the Campo St^a Maria Mater Domini ; another, on the Grand Canal, in the parish of the Apostoli, has two crosses, one on each side of the first story, and a bas-relief of Christ enthroned in the centre ; and finally, that from which the larger cross in the Plate was taken in the house once belonging to Marco Polo, at St. Giovanni Grisostomo.

§ xxvi. This cross, though graceful and rich, and given because it happens to be one of the best preserved, is uncharacteristic in one respect ; for, instead of the central rose at the meeting of the arms, we usually find a hand raised in the attitude of blessing, between the sun and moon, as in the two smaller crosses seen in the Plate. In nearly all representations of the Crucifixion, over the whole of Europe, at the period in

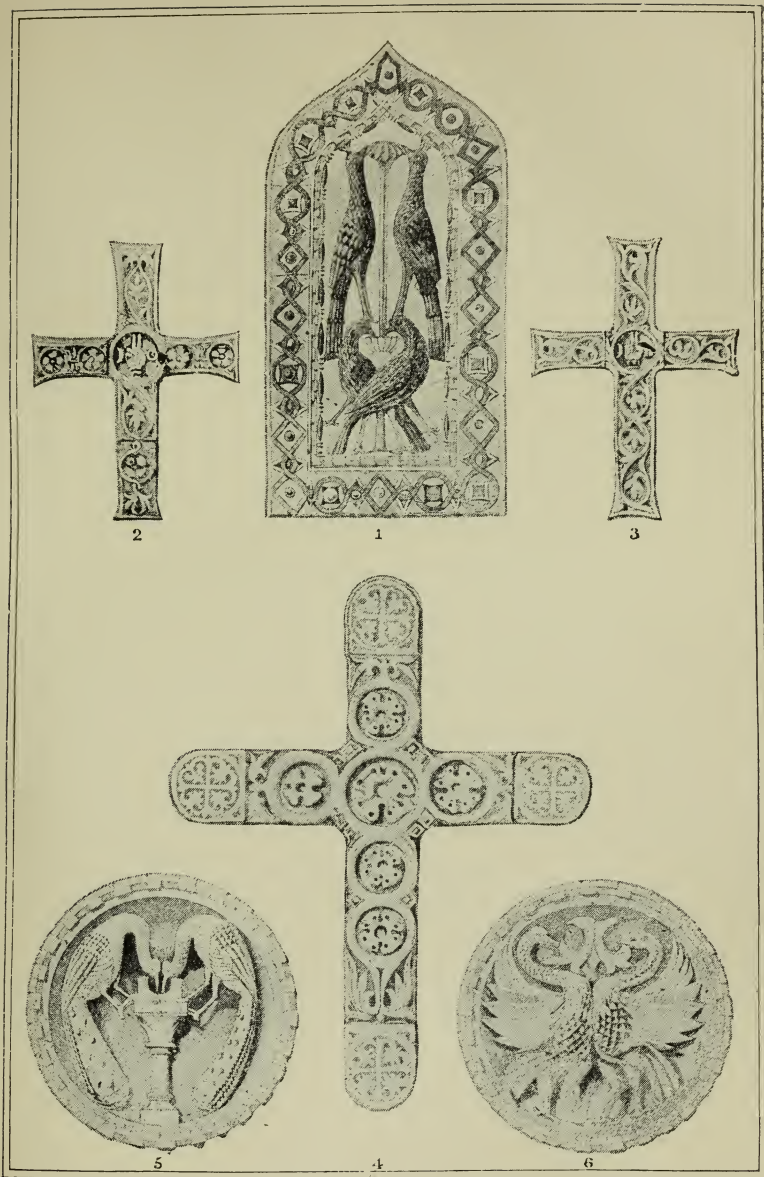

PLATE XI.—BYZANTINE SCULPTURE.

question, the sun and the moon are introduced, one on each side of the cross—the sun generally, in paintings, as a red star ; but I do not think with any purpose of indicating the darkness at the time of the agony ; especially because, had this been the intention, the moon ought not to have been visible, since it could not have been in the heavens during the day at the time of passover. I believe rather that the two luminaries are set there in order to express the entire dependence of the heavens and the earth upon the work of the Redemption : and this view is confirmed by our frequently finding the sun and moon set in the same manner beside the figure of Christ, as in the centre of the great archivolt of St. Mark's, or beside the hand signifying benediction, without any cross, in some other early archivolts ;* while, again, not unfrequently they are absent from the symbol of the cross itself, and its saving power over the whole of creation is indicated only by fresh leaves springing from its foot, or doves feeding beside it ; and so also, in illuminated Bibles, we find the series of pictures representing the Creation terminate in the Crucifixion, as the work by which all the families of created beings subsist, no less than that in sympathy with which “the whole creation groaneth and travaileth in pain together until now.”

§ XXVII. This habit of placing the symbol of the Christian faith in the centres of their palaces was, as I above said, universal in early Venice ; it does not cease till about the middle of the fourteenth century. The other sculptures, which were set above or between the arches, consist almost invariably of groups of birds or beasts ; either standing opposite to each other with a small pillar or spray of leafage between them, or else tearing and devouring each other. The multitude of these sculptures, especially of the small ones enclosed in circles, as figs. 5 and 6, Plate XI, which are now scattered through the city of Venice, is enormous, but they are seldom to be seen in their original positions. When the Byzantine palaces were destroyed, these fragments were generally preserved, and inserted again in the walls of the new buildings,

* Two of these are represented in the second number of my folio work upon Venice.

with more or less attempt at symmetry ; fragments of friezes and mouldings being often used in the same manner ; so that the mode of their original employment can only be seen in St. Mark's, the Fondaco de' Turchi, Braided House, and one or two others. The most remarkable point about them is, that the groups of beasts or birds on each side of the small pillars bear the closest possible resemblance to the group of Lions over the gate of Mycenæ ; and the whole of the ornamentation of that gate, as far as I can judge of it from drawings, is so like Byzantine sculpture, that I cannot help sometimes suspecting the original conjecture of the French antiquarians, that it was a work of the middle ages, to be not altogether indefensible. By far the best among the sculptures at Venice are those consisting of groups thus arranged ; the first figure in Plate XI. is one of those used on St. Mark's, and, with its chain of wreathen work round it, is very characteristic of the finest kind, except that the immediate trunk or pillar often branches into luxuriant leafage, usually of the vine, so that the whole ornament seems almost composed from the words of Ezekiel. "A great eagle with great wings, long-winged, full of feathers, which had divers colors, came into Lebanon, and took the highest branch of the cedar : He cropped off the top of his young twigs ; and *carried it into a city of traffic ; he set it in a city of merchants.* He took also of the seed of the land, . . . and it grew, and became a spreading vine of low stature, *whose branches turned towards him, and the roots thereof were under him.*"

§ xxviii. The groups of contending and devouring animals are always much ruder in cutting, and take somewhat the place in Byzantine sculpture which the lower grotesques do in the Gothic ; true, though clumsy, grotesques being sometimes mingled among them, as four bodies joined to one head in the centre ;* but never showing any attempt at variety of invention, except only in the effective disposition of the light and shade, and in the vigor and thoughtfulness of the touches which indicate the plumes of the birds or folding of the leaves.

* The absence of the true grotesque spirit in Byzantine work will be examined in the third chapter of the third volume.

Care, however, is always taken to secure variety enough to keep the eye entertained, no two sides of these Byzantine ornaments being in all respects the same : for instance, in the chainwork round the first figure in Plate XI. there are two circles enclosing squares on the left-hand side of the arch at the top, but two smaller circles and a diamond on the other, enclosing one square, and two small circular spots or bosses ; and in the line of chain at the bottom there is a circle on the right, and a diamond on the left, and so down to the working of the smallest details. I have represented this upper sculpture as dark, in order to give some idea of the general effect of these ornaments when seen in shadow against light ; an effect much calculated upon by the designer, and obtained by the use of a golden ground formed of glass mosaic inserted in the hollows of the marble. Each square of glass has the leaf gold upon its surface protected by another thin film of glass above it, so that no time or weather can affect its lustre, until the pieces of glass are bodily torn from their setting. The smooth glazed surface of the golden ground is washed by every shower of rain, but the marble usually darkens into an amber color in process of time ; and when the whole ornament is cast into shadow, the golden surface, being perfectly reflective, refuses the darkness, and shows itself in bright and burnished light behind the dark traceries of the ornament. Where the marble has retained its perfect whiteness, on the other hand, and is seen in sunshine, it is shown as a snowy tracery on a golden ground ; and the alternations and intermingling of these two effects form one of the chief enchantments of Byzantine ornamentation.

§ XXIX. How far the system of grounding with gold and color, universal in St. Mark's, was carried out in the sculptures of the private palaces, it is now impossible to say. The wrecks of them which remain, as above noticed, show few of their ornamental sculptures in their original position ; and from those marbles which were employed in succeeding buildings, during the Gothic period, the fragments of their mosaic grounds would naturally rather have been removed than restored. Mosaic, while the most secure of all decorations it

carefully watched and refastened when it loosens, may, if neglected and exposed to weather, in process of time disappear so as to leave no vestige of its existence. However this may have been, the assured facts are, that both the shafts of the pillars and the facing of the old building were of veined or variously colored marble: the capitals and sculptures were either, as they now appear, of pure white marble, relieved upon the veined ground; or, which is infinitely the more probable, grounded in the richer palaces with mosaic of gold, in the inferior ones with blue color; and only the leaves and edges of the sculpture gilded. These brighter hues were opposed by bands of deeper color, generally alternate russet and green, in the archivolts,—bands which still remain in the Casa Loredan and Fondaco de' Turchi, and in a house in the Corte del Remer, near the Rialto, as well as in St. Mark's; and by circular disks of green serpentine and porphyry, which, together with the circular sculptures, appear to have been an ornament peculiarly grateful to the Eastern mind, derived probably in the first instance from the suspension of shields upon the wall, as in the majesty of ancient Tyre. “The men of Arvad with thine army were upon thy walls round about, and the Gammadins were in thy towers: they hanged their shields upon thy walls round about; they have made thy beauty perfect.”* The sweet and solemn harmony of purple with various green (the same, by the by, to which the hills of Scotland owe their best loveliness) remained a favorite chord of color with the Venetians, and was constantly used even in the later palaces; but never could have been seen in so great perfection as when opposed to the pale and delicate sculpture of the Byzantine time.

§ xxx. Such, then, was that first and fairest Venice which rose out of the barrenness of the lagoon, and the sorrow of her people; a city of graceful arcades and gleaming walls, veined with azure and warm with gold, and fretted with white sculpture like frost upon forest branches turned to marble. And yet, in this beauty of her youth, she was no city of thoughtless pleasure. There was still a sadness of heart upon her, and a depth of devotion, in which lay all her strength. I do

* Ezekiel, xxvii. 11.

not insist upon the probable religious signification of many of the sculptures which are now difficult of interpretation ; but the temper which made the cross the principal ornament of every building is not to be misunderstood, nor can we fail to perceive, in many of the minor sculptural subjects, meanings perfectly familiar to the mind of early Christianity. The peacock, used in preference to every other bird, is the well-known symbol of the resurrection ; and when drinking from a fountain (Plate XI. fig. 1) or from a font (Plate XI. fig. 5), is, I doubt not, also a type of the new life received in faithful baptism. The vine, used in preference to all other trees, was equally recognized as, in all cases, a type either of Christ himself* or of those who were in a state of visible or professed union with him. The dove, at its foot, represents the coming of the Comforter ; and even the groups of contending animals had, probably, a distinct and universally apprehended reference to the powers of evil. But I lay no stress on these more occult meanings. The principal circumstance which marks the seriousness of the early Venetian mind is perhaps the last in which the reader would suppose it was traceable ;—that love of bright and pure color which, in a modified form, was afterwards the root of all the triumph of the Venetian schools of painting, but which, in its utmost simplicity, was characteristic of the Byzantine period only ; and of which, therefore, in the close of our review of that period, it will be well that we should truly estimate the significance. The fact is, we none of us enough appreciate the nobleness and sacredness of color. Nothing is more common than to hear it spoken of as a subordinate beauty,—nay, even as the mere source of a sensual pleasure ; and we might almost believe that we were daily among men who

“ Could strip, for aught the prospect yields
 To them, their verdure from the fields ;
 And take the radiance from the clouds
 With which the sun his setting shrouds.”

* Perhaps this type is in no place of Scripture more touchingly used than in Lamentations, i. 12, where the word “ afflicted ” is rendered in the Vulgate “ vindemiavit,” “ vintaged.”

But it is not so. Such expressions are used for the most part in thoughtlessness ; and if the speakers would only take the pains to imagine what the world and their own existence would become, if the blue were taken from the sky, and the gold from the sunshine, and the verdure from the leaves, and the crimson from the blood which is the life of man, the flush from the cheek, the darkness from the eye, the radiance from the hair,—if they could but see for an instant, white human creatures living in a white world,—they would soon feel what they owe to color. The fact is, that, of all God's gifts to the sight of man, color is the holiest, the most divine, the most solemn. We speak rashly of gay color, and sad color, for color cannot at once be good and gay. All good color is in some degree pensive, the loveliest is melancholy, and the purest and most thoughtful minds are those which love color the most.

§ xxxi. I know that this will sound strange in many ears, and will be especially startling to those who have considered the subject chiefly with reference to painting ; for the great Venetian schools of color are not usually understood to be either pure or pensive, and the idea of its pre-eminence is associated in nearly every mind with the coarseness of Rubens, and the sensualities of Correggio and Titian. But a more comprehensive view of art will soon correct this impression. It will be discovered, in the first place, that the more faithful and earnest the religion of the painter, the more pure and prevalent is the system of his color. It will be found, in the second place, that where color becomes a primal intention with a painter otherwise mean or sensual, it instantly elevates him, and becomes the one sacred and saving element in his work. The very depth of the stoop to which the Venetian painters and Rubens sometimes condescend, is a consequence of their feeling confidence in the power of their color to keep them from falling. They hold on by it, as by a chain let down from heaven, with one hand, though they may sometimes seem to gather dust and ashes with the other. And, in the last place, it will be found that so surely as a painter is irreligious, thoughtless, or obscene in disposition, so surely

is his coloring cold, gloomy, and valueless. The opposite poles of art in this respect are Frà Angelico and Salvator Rosa ; of whom the one was a man who smiled seldom, wept often, prayed constantly, and never harbored an impure thought. His pictures are simply so many pieces of jewellery, the colors of the draperies being perfectly pure, as various as those of a painted window, chastened only by paleness, and relieved upon a gold ground. Salvator was a dissipated jester and satirist, a man who spent his life in masquing and revelry. But his pictures are full of horror, and their color is for the most part gloomy grey. Truly it would seem as if art had so much of eternity in it, that it must take its dye from the close rather than the course of life:—"In such laughter the heart of man is sorrowful, and the end of that mirth is heaviness."

§ xxxii. These are no singular instances. I know no law more severely without exception than this of the connexion of pure color with profound and noble thought. The late Flemish pictures, shallow in conception and obscene in subject, are always sober in color. But the early religious painting of the Flemings is as brilliant in hue as it is holy in thought. The Bellinis, Francias, Peruginos painted in crimson, and blue, and gold. The Caraccis, Guidos, and Rembrandts in brown and grey. The builders of our great cathedrals veiled their casements and wrapped their pillars with one robe of purple splendor. The builders of the luxurious Renaissance left their palaces filled only with cold white light, and in the paleness of their native stone.*

§ xxxiii. Nor does it seem difficult to discern a noble reason for this universal law. In that heavenly circle which binds the statutes of color upon the front of the sky, when it became the sign of the covenant of peace, the pure hues of divided light were sanctified to the human heart for ever ; nor this, it would seem, by mere arbitrary appointment, but in consequence of the fore-ordained and marvellous constitution of those hues into a sevenfold, or, more strictly still, a threefold order, typical of the Divine nature itself. Observe also

* Appendix 12, "Modern Painting on Glass."

the name Shem, or Splendor, given to that son of Nosh in whom this covenant with mankind was to be fulfilled, and see how that name was justified by every one of the Asiatic races which descended from him. Not without meaning was the love of Israel to his chosen son expressed by the coat "of many colors;" not without deep sense of the sacredness of that symbol of purity, did the lost daughter of David tear it from her breast:—"With such robes were the king's daughters that were virgins apparelled."* We know it to have been by Divine command that the Israelite, rescued from servitude, veiled the tabernacle with its rain of purple and scarlet, while the under sunshine flashed through the fall of the color from its tenons of gold: but was it less by Divine guidance that the Mede, as he struggled out of anarchy, encompassed his king with the sevenfold burning of the battlements of Ecbatana?—of which one circle was golden like the sun, and another silver like the moon; and then came the great sacred chord of color, blue, purple, and scarlet; and then a circle white like the day, and another dark, like night; so that the city rose like a great mural rainbow, a sign of peace amidst the contending of lawless races, and guarded, with color and shadow, that seemed to symbolize the great order which rules over Day, and Night, and Time, the first organization of the mighty statutes,—the law of the Medes and Persians, that altereth not.

§ xxxiv. Let us not dream that it is owing to the accidents of tradition or education that those races possess the supremacy over color which has always been felt, though but lately acknowledged among men. However their dominion might be broken, their virtue extinguished, or their religion defiled, they retained alike the instinct and the power: the instinct which made even their idolatry more glorious than that of others, bursting forth in fire-worship from pyramid, cave, and mountain, taking the stars for the rulers of its fortune, and the sun for the God of its life; the power which so dazzled and subdued the rough crusader into forgetfulness of sorrow and of shame, that Europe put on the splendor which she had

* 2 Samuel, xiii. 18.

learnt of the Saracen, as her sackcloth of mourning for what she suffered from his sword ;—the power which she confesses to this day, in the utmost thoughtlessness of her pride, or her beauty, as it treads the costly carpet, or veils itself with the variegated Cachemire ; and in the emulation of the concourse of her workmen, who, but a few months back, perceived, or at least admitted, for the first time, the pre-eminence which has been determined from the birth of mankind, and on whose charter Nature herself has set a mysterious seal, granting to the Western races, descended from that son of Noah whose name was Extension, the treasures of the sullen rock, and stubborn ore, and gnarled forest, which were to accomplish their destiny across all distance of earth and depth of sea, while she matured the jewel in the sand, and rounded the pearl in the shell, to adorn the diadem of him whose name was Splendor.

§ xxxv. And observe, farther, how in the Oriental mind a peculiar seriousness is associated with this attribute of the love of color ; a seriousness rising out of repose, and out of the depth and breadth of the imagination, as contrasted with the activity, and consequent capability of surprise, and of laughter, characteristic of the Western mind : as a man on a journey must look to his steps always, and view things narrowly and quickly ; while one at rest may command a wider view, though an unchanging one, from which the pleasure he receives must be one of contemplation, rather than of amusement or surprise. Wherever the pure Oriental spirit manifests itself definitely, I believe its work is serious ; and the meeting of the influences of the Eastern and Western races is perhaps marked in Europe more by the dying away of the grotesque laughter of the Goth than by any other sign. I shall have more to say on this head in other places of this volume ; but the point I wish at present to impress upon the reader is, that the bright hues of the early architecture of Venice were no sign of gaiety of heart, and that the investiture with the mantle of many colors by which she is known above all other cities of Italy and of Europe, was not granted to her in the fever of her festivity, but in the solemnity of her

early and earnest religion. She became in after times the revel of the earth, the masque of Italy; and *therefore* is she now desolate: but her glorious robe of gold and purple was given her when first she rose a vestal from the sea, not when she became drunk with the wine of her fornication.

§ xxxvi. And we have never yet looked with enough reverence upon the separate gift which was thus bestowed upon her; we have never enough considered what an inheritance she has left us, in the works of those mighty painters who were the chief of her children. That inheritance is indeed less than it ought to have been, and other than it ought to have been; for before Titian and Tintoret arose,—the men in whom her work and her glory should have been together consummated,—she had already ceased to lead her sons in the way of truth and life, and they erred much, and fell short of that which was appointed for them. There is no subject of thought more melancholy, more wonderful, than the way in which God permits so often His best gifts to be trodden under foot of men, His richest treasures to be wasted by the moth, and the mightiest influences of His Spirit, given but once in the world's history, to be quenched and shortened by miseries of chance and guilt. I do not wonder at what men Suffer, but I wonder often at what they Lose. We may see how good rises out of pain and evil; but the dead, naked, eyeless loss, what good comes of that? The fruit struck to the earth before its ripeness; the glowing life and goodly purpose dissolved away in sudden death; the words, half spoken, choked upon the lips with clay for ever; or, stranger than all, the whole majesty of humanity raised to its fulness, and every gift and power necessary for a given purpose, at a given moment, centred in one man, and all this perfected blessing permitted to be refused, perverted, crushed, cast aside by those who need it most,—the city which is Not set on a hill, the candle that giveth light to None that are in the house:—these are the heaviest mysteries of this strange world, and, it seems to me, those which mark its curse the most. And it is true that the power with which this Venice had been entrusted, was perverted, when at its highest, in a thousand miserable ways;

still, it was possessed by her alone ; to her all hearts have turned which could be moved by its manifestation, and none without being made stronger and nobler by what her hand had wrought. That mighty Landscape, of dark mountains that guard the horizon with their purple towers, and solemn forests, that gather their weight of leaves, bronzed with sunshine, not with age, into those gloomy masses fixed in heaven, which storm and frost have power no more to shake, or shed ; —that mighty Humanity, so perfect and so proud, that hides no weakness beneath the mantle, and gains no greatness from the diadem ; the majesty of thoughtful form, on which the dust of gold and flame of jewels are dashed as the sea-spray upon the rock, and still the great Manhood seems to stand bare against the blue sky ;—that mighty Mythology, which fills the daily walks of men with spiritual companionship, and beholds the protecting angels break with their burning presence through the arrow-flights of battle :—measure the compass of that field of creation, weigh the value of the inheritance that Venice thus left to the nations of Europe, and then judge if so vast, so beneficent a power could indeed have been rooted in dissipation or decay. It was when she wore the ephod of the priest, not the motley of the masquer, that the fire fell upon her from heaven ; and she saw the first rays of it through the rain of her own tears, when, as the barbaric deluge ebbed from the hills of Italy, the circuit of her palaces, and the orb of her fortunes, rose together, like the Iris, painted upon the Cloud.

SECOND, OR GOTHIC, PERIOD.

CHAPTER VI.

THE NATURE OF GOTHIC.

§ I. IF the reader will look back to the division of our subject which was made in the first chapter of the first volume, he will find that we are now about to enter upon the examination of that school of Venetian architecture which forms an intermediate step between the Byzantine and Gothic forms; but which I find may be conveniently considered in its connexion with the latter style. In order that we may discern the tendency of each step of this change, it will be wise in the outset to endeavor to form some general idea of its final result. We know already what the Byzantine architecture is from which the transition was made, but we ought to know something of the Gothic architecture into which it led. I shall endeavor therefore to give the reader in this chapter an idea, at once broad and definite, of the true nature of *Gothic* architecture, properly so called; not of that of Venice only, but of universal Gothic: for it will be one of the most interesting parts of our subsequent inquiry, to find out how far Venetian architecture reached the universal or perfect type of Gothic, and how far it either fell short of it, or assumed foreign and independent forms.

§ II. The principal difficulty in doing this arises from the fact that every building of the Gothic period differs in some important respect from every other; and many include features which, if they occurred in other buildings, would not be considered Gothic at all; so that all we have to reason upon is merely, if I may be allowed so to express it, a greater or less

degree of *Gothicness* in each building we examine. And it is this Gothicness,—the character which, according as it is found more or less in a building, makes it more or less Gothic,—of which I want to define the nature; and I feel the same kind of difficulty in doing so which would be encountered by any one who undertook to explain, for instance, the nature of Redness, without any actual red thing to point to, but only orange and purple things. Suppose he had only a piece of heather and a dead oak-leaf to do it with. He might say, the color which is mixed with the yellow in this oak-leaf, and with the blue in this heather, would be red, if you had it separate; but it would be difficult, nevertheless, to make the abstraction perfectly intelligible: and it is so in a far greater degree to make the abstraction of the Gothic character intelligible, because that character itself is made up of many mingled ideas, and can consist only in their union. That is to say, pointed arches do not constitute Gothic, nor vaulted roofs, nor flying buttresses, nor grotesque sculptures; but all or some of these things, and many other things with them, when they come together so as to have life.

§ III. Observe also, that, in the definition proposed, I shall only endeavor to analyze the idea which I suppose already to exist in the reader's mind. We all have some notion, most of us a very determined one, of the meaning of the term Gothic; but I know that many persons have this idea in their minds without being able to define it: that is to say, understanding generally that Westminster Abbey is Gothic, and St. Paul's is not, that Strasburg Cathedral is Gothic, and St. Peter's is not, they have, nevertheless, no clear notion of what it is that they recognize in the one or miss in the other, such as would enable them to say how far the work at Westminster or Strasburg is good and pure of its kind: still less to say of any non-descript building, like St. James's Palace or Windsor Castle, how much right Gothic element there is in it, and how much wanting. And I believe this inquiry to be a pleasant and profitable one; and that there will be found something more than usually interesting in tracing out this grey, shadowy, many-pinnacled image of the Gothic spirit within us; and discern-

ing what fellowship there is between it and our Northern hearts. And if, at any point of the inquiry, I should interfere with any of the reader's previously formed conceptions, and use the term Gothic in any sense which he would not willingly attach to it, I do not ask him to accept, but only to examine and understand, my interpretation, as necessary to the intelligibility of what follows in the rest of the work.

§ iv. We have, then, the Gothic character submitted to our analysis, just as the rough mineral is submitted to that of the chemist, entangled with many other foreign substances, itself perhaps in no place pure, or ever to be obtained or seen in purity for more than an instant ; but nevertheless a thing of definite and separate nature, however inextricable or confused in appearance. Now observe : the chemist defines his mineral by two separate kinds of character ; one external, its crystalline form, hardness, lustre, &c. ; the other internal, the proportions and nature of its constituent atoms. Exactly in the same manner, we shall find that Gothic architecture has external forms, and internal elements. Its elements are certain mental tendencies of the builders, legibly expressed in it ; as fancifulness, love of variety, love of richness, and such others. Its external forms are pointed arches, vaulted roofs, &c. And unless both the elements and the forms are there, we have no right to call the style Gothic. It is not enough that it has the Form, if it have not also the power and life. It is not enough that it has the Power, if it have not the form. We must therefore inquire into each of these characters successively ; and determine first, what is the Mental Expression, and secondly, what the Material Form, of Gothic architecture, properly so called.

1st. Mental Power or Expression. What characters, we have to discover, did the Gothic builders love, or instinctively express in their work, as distinguished from all other builders ?

§ v. Let us go back for a moment to our chemistry, and note that, in defining a mineral by its constituent parts, it is not one nor another of them, that can make up the mineral, but the union of all : for instance, it is neither in charcoal, nor in oxygen, nor in lime, that there is the making of chalk, but

in the combination of all three in certain measures, they are all found in very different things from chalk, and there is nothing like chalk either in charcoal or in oxygen, but they are nevertheless necessary to its existence.

So in the various mental characters which make up the soul of Gothic. It is not one nor another that produces it; but their union in certain measures. Each one of them is found in many other architectures besides Gothic; but Gothic cannot exist where they are not found, or, at least, where their place is not in some way supplied. Only there is this great difference between the composition of the mineral, and of the architectural style, that if we withdraw one of its elements from the stone, its form is utterly changed, and its existence as such and such a mineral is destroyed; but if we withdraw one of its mental elements from the Gothic style, it is only a little less Gothic than it was before, and the union of two or three of its elements is enough already to bestow a certain Gothicness of character, which gains in intensity as we add the others, and loses as we again withdraw them.

§ VI. I believe, then, that the characteristic or moral elements of Gothic are the following, placed in the order of their importance:

- | | |
|-------------------|-------------------|
| 1. Savageness. | 4. Grotesqueness. |
| 2. Changefulness. | 5. Rigidity. |
| 3. Naturalism. | 6. Redundance. |

These characters are here expressed as belonging to the building; as belonging to the builder, they would be expressed thus: 1. Savageness, or Rudeness. 2. Love of Change. 3. Love of Nature. 4. Disturbed Imagination. 5. Obstinacy. 6. Generosity. And I repeat, that the withdrawal of any one, or any two, will not at once destroy the Gothic character of a building, but the removal of a majority of them will. I shall proceed to examine them in their order.

§ VII. 1. SAVAGENESS. I am not sure when the word "Gothic" was first generically applied to the architecture of the North; but I presume that, whatever the date of its original usage, it was intended to imply reproach, and express

the barbaric character of the nations among whom that architecture arose. It never implied that they were literally of Gothic lineage, far less that their architecture had been originally invented by the Goths themselves ; but it did imply that they and their buildings together exhibited a degree of sternness and rudeness, which, in contradistinction to the character of Southern and Eastern nations, appeared like a perpetual reflection of the contrast between the Goth and the Roman in their first encounter. And when that fallen Roman, in the utmost impotence of his luxury, and insolence of his guilt, became the model for the imitation of civilized Europe, at the close of the so-called Dark ages, the word Gothic became a term of unmitigated contempt, not unmixed with aversion. From that contempt, by the exertion of the antiquaries and architects of this century, Gothic architecture has been sufficiently vindicated ; and perhaps some among us, in our admiration of the magnificent science of its structure, and sacredness of its expression, might desire that the term of ancient reproach should be withdrawn, and some other, of more apparent honorableness, adopted in its place. There is no chance, as there is no need, of such a substitution. As far as the epithet was used scornfully, it was used falsely ; but there is no reproach in the word, rightly understood ; on the contrary, there is a profound truth, which the instinct of mankind almost unconsciously recognizes. It is true, greatly and deeply true, that the architecture of the North is rude and wild ; but it is not true, that, for this reason, we are to condemn it, or despise. Far otherwise : I believe it is in this very character that it deserves our profoundest reverence.

§ VIII. The charts of the world which have been drawn up by modern science have thrown into a narrow space the expression of a vast amount of knowledge, but I have never yet seen any one pictorial enough to enable the spectator to imagine the kind of contrast in physical character which exists between Northern and Southern countries. We know the differences in detail, but we have not that broad glance and grasp which would enable us to feel them in their fulness. We know that gentians grow on the Alps, and olives on the

Apennines ; but we do not enough conceive for ourselves that variegated mosaic of the world's surface which a bird sees in its migration, that difference between the district of the gen-tian and of the olive which the stork and the swallow see far off, as they lean upon the sirocco wind. Let us, for a moment, try to raise ourselves even above the level of their flight, and imagine the Mediterranean lying beneath us like an irregular lake, and all its ancient promontories sleeping in the sun : here and there an angry spot of thunder, a grey stain of storm, moving upon the burning field ; and here and there a fixed wreath of white volcano smoke, surrounded by its circle of ashes ; but for the most part a great peacefulness of light, Syria and Greece, Italy and Spain, laid like pieces of a golden pavement into the sea-blue, chased, as we stoop nearer to them, with bossy beaten work of mountain chains, and glowing softly with terraced gardens, and flowers heavy with frankincense, mixed among masses of laurel, and orange and plummy palm, that abate with their grey-green shadows the burning of the marble rocks, and of the ledges of porphyry sloping under lucent sand. Then let us pass farther towards the north, until we see the orient colors change gradually into a vast belt of rainy green, where the pastures of Switzerland, and poplar valleys of France, and dark forests of the Danube and Carpathians stretch from the mouths of the Loire to those of the Volga, seen through clefts in grey swirls of rain-cloud and flaky veils of the mist of the brooks, spreading low along the pasture lands : and then, farther north still, to see the earth heave into mighty masses of leaden rock and heathy moor, bordering with a broad waste of gloomy purple that belt of field and wood, and splintering into irregular and grisly islands amidst the northern seas, beaten by storm and chilled by ice-drift, and tormented by furious pulses of contending tide, until the roots of the last forests fail from among the hill ravines, and the hunger of the north wind bites their peaks into barrenness ; and, at last, the wall of ice, durable like iron, sets, deathlike, its white teeth against us out of the polar twilight. And, having once traversed in thought its gradation of the zoned iris of the earth in all its material vastness, let us

go down nearer to it, and watch the parallel change in the belt of animal life: the multitudes of swift and brilliant creatures that glance in the air and sea, or tread the sands of the southern zone; striped zebras and spotted leopards, glistening serpents, and birds arrayed in purple and scarlet. Let us contrast their delicacy and brilliancy of color, and swiftness of motion, with the frost-cramped strength, and shaggy covering, and dusky plumage of the northern tribes; contrast the Arabian horse with the Shetland, the tiger and leopard with the wolf and bear, the antelope with the elk, the bird of paradise with the osprey: and then, submissively acknowledging the great laws by which the earth and all that it bears are ruled throughout their being, let us not condemn, but rejoice at the expression by man of his own rest in the statutes of the lands that gave him birth. Let us watch him with reverence as he sets side by side the burning gems, and smoothes with soft sculpture the jasper pillars, that are to reflect a ceaseless sunshine, and rise into a cloudless sky: but not with less reverence let us stand by him, when, with rough strength and hurried stroke, he smites an uncouth animation out of the rocks which he has torn from among the moss of the moorland, and heaves into the darkened air the pile of iron buttress and rugged wall, instinct with work of an imagination as wild and wayward as the northern sea; creations of ungainly shape and rigid limb, but full of wolfish life; fierce as the winds that beat, and changeful as the clouds that shade them.

There is, I repeat, no degradation, no reproach in this, but all dignity and honorableness; and we should err grievously in refusing either to recognise as an essential character of the existing architecture of the North, or to admit as a desirable character in that which it yet may be, this wildness of thought, and roughness of work; this look of mountain brotherhood between the cathedral and the Alp; this magnificence of sturdy power, put forth only the more energetically because the fine finger-touch was chilled away by the frosty wind, and the eye dimmed by the moor-mist, or blinded by the hail; this out-speaking of the strong spirit of men who may not gather re-

dundant fruitage from the earth, nor bask in dreamy benignity of sunshine, but must break the rock for bread, and cleave the forest for fire, and show, even in what they did for their delight, some of the hard habits of the arm and heart that grew on them as they swung the axe or pressed the plough.

§ IX. If, however, the savageness of Gothic architecture, merely as an expression of its origin among Northern nations, may be considered, in some sort, a noble character, it possesses a higher nobility still, when considered as an index, not of climate, but of religious principle.

In the 13th and 14th paragraphs of Chapter XXI. of the first volume of this work, it was noticed that the systems of architectural ornament, properly so called, might be divided into three:—1. Servile ornament, in which the execution or power of the inferior workman is entirely subjected to the intellect of the higher:—2. Constitutional ornament, in which the executive inferior power is, to a certain point, emancipated and independent, having a will of its own, yet confessing its inferiority and rendering obedience to higher powers;—and 3. Revolutionary ornament, in which no executive inferiority is admitted at all. I must here explain the nature of these divisions at somewhat greater length.

Of Servile ornament, the principal schools are the Greek, Ninevite, and Egyptian; but their servility is of different kinds. The Greek master-workman was far advanced in knowledge and power above the Assyrian or Egyptian. Neither he nor those for whom he worked could endure the appearance of imperfection in anything; and, therefore, what ornament he appointed to be done by those beneath him was composed of mere geometrical forms,—balls, ridges, and perfectly symmetrical foliage,—which could be executed with absolute precision by line and rule, and were as perfect in their way when completed, as his own figure sculpture. The Assyrian and Egyptian, on the contrary, less cognizant of accurate form in anything, were content to allow their figure sculpture to be executed by inferior workmen, but lowered the method of its treatment to a standard which every workman could reach, and then trained him by discipline so rigid, that there

was no chance of his falling beneath the standard appointed. The Greek gave to the lower workman no subject which he could not perfectly execute. The Assyrian gave him subjects which he could only execute imperfectly, but fixed a legal standard for his imperfection. The workman was, in both systems, a slave.*

§ x. But in the mediæval, or especially Christian, system of ornament, this slavery is done away with altogether; Christianity having recognized, in small things as well as great, the individual value of every soul. But it not only recognizes its value; it confesses its imperfection, in only bestowing dignity upon the acknowledgment of unworthiness. That admission of lost power and fallen nature, which the Greek or Ninevite felt to be intensely painful, and, as far as might be, altogether refused, the Christian makes daily and hourly, contemplating the fact of it without fear, as tending, in the end, to God's greater glory. Therefore, to every spirit which Christianity summons to her service, her exhortation is: Do what you can, and confess frankly what you are unable to do; neither let your effort be shortened for fear of failure, nor your confession silenced for fear of shame. And it is, perhaps, the principal admirableness of the Gothic schools of architecture, that they thus receive the results of the labor of inferior minds; and out of fragments full of imperfection, and betraying that imperfection in every touch, indulgently raise up a stately and unaccusable whole.

§ xi. But the modern English mind has this much in common with that of the Greek, that it intensely desires, in all things, the utmost completion or perfection compatible with their nature. This is a noble character in the abstract, but

* The third kind of ornament, the Renaissance, is that in which the inferior detail becomes principal, the executor of every minor portion being required to exhibit skill and possess knowledge as great as that which is possessed by the master of the design; and in the endeavor to endow him with this skill and knowledge, his own original power is overwhelmed, and the whole building becomes a wearisome exhibition of well-educated imbecility. We must fully inquire into the nature of this form of error, when we arrive at the examination of the Renaissance schools

becomes ignoble when it causes us to forget the relative dignities of the nature itself, and to prefer the perfectness of the lower nature to the imperfection of the higher ; not considering that as, judged by such a rule, all the brute animals would be preferable to man, because more perfect in their functions and kind, and yet are always held inferior to him, so also in the works of man, those which are more perfect in their kind are always inferior to those which are, in their nature, liable to more faults and shortcomings. For the finer the nature, the more flaws it will show through the clearness of it ; and it is a law of this universe, that the best things shall be seldomest seen in their best form. The wild grass grows well and strongly, one year with another ; but the wheat is, according to the greater nobleness of its nature, liable to the bitterer blight. And therefore, while in all things that we see, or do, we are to desire perfection, and strive for it, we are nevertheless not to set the meaner thing, in its narrow accomplishment, above the nobler thing, in its mighty progress ; not to esteem smooth minuteness above shattered majesty ; not to prefer mean victory to honorable defeat ; not to lower the level of our aim, that we may the more surely enjoy the complacency of success. But, above all, in our dealings with the souls of other men, we are to take care how we check, by severe requirement or narrow caution, efforts which might otherwise lead to a noble issue ; and, still more, how we withhold our admiration from great excellences, because they are mingled with rough faults. Now, in the make and nature of every man, however rude or simple, whom we employ in manual labor, there are some powers for better things : some tardy imagination, torpid capacity of emotion, tottering steps of thought, there are, even at the worst ; and in most cases it is all our own fault that they *are* tardy or torpid. But they cannot be strengthened, unless we are content to take them in their feebleness, and unless we prize and honor them in their imperfection above the best and most perfect manual skill. And this is what we have to do with all our laborers ; to look for the *thoughtful* part of them, and get that out of them, whatever we lose for it, whatever faults and errors we are obliged to take with it. For the

best that is in them cannot manifest itself, but in company with much error. Understand this clearly: You can teach a man to draw a straight line, and to cut one; to strike a curved line, and to carve it; and to copy and carve any number of given lines or forms, with admirable speed and perfect precision; and you find his work perfect of its kind: but if you ask him to think about any of those forms, to consider if he cannot find any better in his own head, he stops; his execution becomes hesitating; he thinks, and ten to one he thinks wrong; ten to one he makes a mistake in the first touch he gives to his work as a thinking being. But you have made a man of him for all that. He was only a machine before, an animated tool.

§ XII. And observe, you are put to stern choice in this matter. You must either make a tool of the creature, or a man of him. You cannot make both. Men were not intended to work with the accuracy of tools, to be precise and perfect in all their actions. If you will have that precision out of them, and make their fingers measure degrees like cog-wheels, and their arms strike curves like compasses, you must un-humanize them. All the energy of their spirits must be given to make cogs and compasses of themselves. All their attention and strength must go to the accomplishment of the mean act. The eye of the soul must be bent upon the finger-point, and the soul's force must fill all the invisible nerves that guide it, ten hours a day, that it may not err from its steely precision, and so soul and sight be worn away, and the whole human being be lost at last—a heap of sawdust, so far as its intellectual work in this world is concerned; saved only by its Heart, which cannot go into the form of cogs and compasses, but expands, after the ten hours are over, into fireside humanity. On the other hand, if you will make a man of the working creature, you cannot make a tool. Let him but begin to imagine, to think, to try to do anything worth doing; and the engine-turned precision is lost at once. Out come all his roughness, all his dulness, all his incapability; shame upon shame, failure upon failure, pause after pause: but out comes the whole majesty of him also; and we know

the height of it only, when we see the clouds settling upon him. And, whether the clouds be bright or dark, there will be transfiguration behind and within them.

§ XIII. And now, reader, look round this English room of yours, about which you have been proud so often, because the work of it was so good and strong, and the ornaments of it so finished. Examine again all those accurate mouldings, and perfect polishings, and unerring adjustments of the seasoned wood and tempered steel. Many a time you have exulted over them, and thought how great England was, because her slightest work was done so thoroughly. Alas! if read rightly, these perfectnesses are signs of a slavery in our England a thousand times more bitter and more degrading than that of the scourged African, or helot Greek. Men may be beaten, chained, tormented, yoked like cattle, slaughtered like summer flies, and yet remain in one sense, and the best sense, free. But to smother their souls within them, to blight and hew into rotting pollards the suckling branches of their human intelligence, to make the flesh and skin which, after the worm's work on it, is to see God, into leathern thongs to yoke machinery with,—this it is to be slave-masters indeed; and there might be more freedom in England, though her feudal lords' lightest words were worth men's lives, and though the blood of the vexed husbandman dropped in the furrows of her fields, than there is while the animation of her multitudes is sent like fuel to feed the factory smoke, and the strength of them is given daily to be wasted into the fineness of a web, or racked into the exactness of a line.

§ XIV. And, on the other hand, go forth again to gaze upon the old cathedral front, where you have smiled so often at the fantastic ignorance of the old sculptors: examine once more those ugly goblins, and formless monsters, and stern statues, anatomiless and rigid; but do not mock at them, for they are signs of the life and liberty of every workman who struck the stone; a freedom of thought, and rank in scale of being, such as no laws, no charters, no charities can secure; but which it must be the first aim of all Europe at this day to regain for her children.

§ xv. Let me not be thought to speak wildly or extravagantly. It is verily this degradation of the operative into a machine, which, more than any other evil of the times, is leading the mass of the nations everywhere into vain, incoherent, destructive struggling for a freedom of which they cannot explain the nature to themselves. Their universal outcry against wealth, and against nobility, is not forced from them either by the pressure of famine, or the sting of mortified pride. These do much, and have done much in all ages; but the foundations of society were never yet shaken as they are at this day. It is not that men are ill fed, but that they have no pleasure in the work by which they make their bread and therefore look to wealth as the only means of pleasure. It is not that men are pained by the scorn of the upper classes, but they cannot endure their own; for they feel that the kind of labor to which they are condemned is verily a degrading one, and makes them less than men. Never had the upper classes so much sympathy with the lower, or charity for them, as they have at this day, and yet never were they so much hated by them: for, of old, the separation between the noble and the poor was merely a wall built by law; now it is a veritable difference in level of standing, a precipice between upper and lower grounds in the field of humanity, and there is pestilential air at the bottom of it. I know not if a day is ever to come when the nature of right freedom will be understood, and when men will see that to obey another man, to labor for him, yield reverence to him or to his place, is not slavery. It is often the best kind of liberty,—liberty from care. The man who says to one, Go, and he goeth, and to another, Come, and he cometh, has, in most cases, more sense of restraint and difficulty than the man who obeys him. The movements of the one are hindered by the burden on his shoulder; of the other, by the bridle on his lips: there is no way by which the burden may be lightened; but we need not suffer from the bridle if we do not champ at it. To yield reverence to another, to hold ourselves and our lives at his disposal, is not slavery; often, it is the noblest state in which a man can live in this world. There is, indeed, a reverence which is servile,

that is to say, irrational or selfish: but there is also noble reverence, that is to say, reasonable and loving; and a man is never so noble as when he is reverent in this kind; nay, even if the feeling pass the bounds of mere reason, so that it be loving, a man is raised by it. Which had, in reality, most of the serf nature in him,—the Irish peasant who was lying in wait yesterday for his landlord, with his musket muzzle thrust through the ragged hedge; or that old mountain servant, who, 200 years ago, at Inverkeithing, gave up his own life and the lives of his seven sons for his chief?—and as each fell, calling forth his brother to the death, “Another for Hector!” And therefore, in all ages and all countries, reverence has been paid and sacrifice made by men to each other, not only without complaint, but rejoicingly; and famine, and peril, and sword, and all evil, and all shame, have been borne willingly in the causes of masters and kings; for all these gifts of the heart ennobled the men who gave, not less than the men who received them, and nature prompted, and God rewarded the sacrifice. But to feel their souls withering within them, unthanked, to find their whole being sunk into an unrecognized abyss, to be counted off into a heap of mechanism, numbered with its wheels, and weighed with its hammer strokes;—this nature bade not,—this God blesses not,—this humanity for no long time is able to endure.

§ xvi. We have much studied and much perfected, of late, the great civilized invention of the division of labor; only we give it a false name. It is not, truly speaking, the labor that is divided; but the men:—Divided into mere segments of men—broken into small fragments and crumbs of life; so that all the little piece of intelligence that is left in a man is not enough to make a pin, or a nail, but exhausts itself in making the point of a pin, or the head of a nail. Now it is a good and desirable thing, truly, to make many pins in a day; but if we could only see with what crystal sand their points were polished,—sand of human soul, much to be magnified before it can be discerned for what it is,—we should think there might be some loss in it also. And the great cry that

* Vide Preface to “Fair Maid of Perth.”

rises from all our manufacturing cities, louder than their furnace blast, is all in very deed for this,—that we manufacture everything there except men; we blanch cotton, and strengthen steel, and refine sugar, and shape pottery; but to brighten, to strengthen, to refine, or to form a single living spirit, never enters into our estimate of advantages. And all the evil to which that cry is urging our myriads can be met only in one way: not by teaching nor preaching, for to teach them is but to show them their misery, and to preach to them, if we do nothing more than preach, is to mock at it. It can be met only by a right understanding, on the part of all classes, of what kinds of labor are good for men, raising them, and making them happy; by a determined sacrifice of such convenience, or beauty, or cheapness as is to be got only by the degradation of the workman; and by equally determined demand for the products and results of healthy and ennobling labor.

§ xvii. And how, it will be asked, are these products to be recognized, and this demand to be regulated? Easily: by the observance of three broad and simple rules:

1. Never encourage the manufacture of any article not absolutely necessary, in the production of which *Invention* has no share.

2. Never demand an exact finish for its own sake, but only for some practical or noble end.

3. Never encourage imitation or copying of any kind, except for the sake of preserving record of great works.

The second of these principles is the only one which directly rises out of the consideration of our immediate subject; but I shall briefly explain the meaning and extent of the first also, reserving the enforcement of the third for another place.

1. Never encourage the manufacture of anything not necessary, in the production of which invention has no share.

For instance. Glass beads are utterly unnecessary, and there is no design or thought employed in their manufacture. They are formed by first drawing out the glass into rods; these rods are chopped up into fragments of the size of beads by the human hand, and the fragments are then rounded in

the furnace. The men who chop up the rods sit at their work all day, their hands vibrating with a perpetual and exquisitely timed palsy, and the beads dropping beneath their vibration like hail. Neither they, nor the men who draw out the rods, or fuse the fragments, have the smallest occasion for the use of any single human faculty ; and every young lady, therefore, who buys glass beads is engaged in the slave-trade, and in a much more cruel one than that which we have so long been endeavoring to put down.

But glass cups and vessels may become the subjects of exquisite invention ; and if in buying these we pay for the invention, that is to say for the beautiful form, or color, or engraving, and not for mere finish of execution, we are doing good to humanity.

§ XVIII. So, again, the cutting of precious stones, in all ordinary cases, requires little exertion of any mental faculty ; some tact and judgment in avoiding flaws, and so on, but nothing to bring out the whole mind. Every person who wears cut jewels merely for the sake of their value is, therefore, a slave-driver.

But the working of the goldsmith, and the various designing of grouped jewellery and enamel-work, may become the subject of the most noble human intelligence. Therefore, money spent in the purchase of well-designed plate, of precious engraved vases, cameos, or enamels, does good to humanity ; and, in work of this kind, jewels may be employed to heighten its splendor ; and their cutting is then a price paid for the attainment of a noble end, and thus perfectly allowable.

§ XIX. I shall perhaps press this law farther elsewhere, but our immediate concern is chiefly with the second, namely, never to demand an exact finish, when it does not lead to a noble end. For observe, I have only dwelt upon the rudeness of Gothic, or any other kind of imperfectness, as admirable, where it was impossible to get design or thought without it. If you are to have the thought of a rough and untaught man, you must have it in a rough and untaught way ; but from an educated man, who can without effort express his thoughts in

an educated way, take the graceful expression, and be thankful. Only *get* the thought, and do not silence the peasant because he cannot speak good grammar, or until you have taught him his grammar. Grammar and refinement are good things, both, only be sure of the better thing first. And thus in art, delicate finish is desirable from the greatest masters, and is always given by them. In some places Michael Angelo, Leonardo, Phidias, Perugino, Turner, all finished with the most exquisite care; and the finish they give always leads to the fuller accomplishment of their noble purposes. But lower men than these cannot finish, for it requires consummate knowledge to finish consummately, and then we must take their thoughts as they are able to give them. So the rule is simple: Always look for invention first, and after that, for such execution as will help the invention, and as the inventor is capable of without painful effort, and *no more*. Above all, demand no refinement of execution where there is no thought, for that is slaves' work, unredeemed. Rather choose rough work than smooth work, so only that the practical purpose be answered, and never imagine there is reason to be proud of anything that may be accomplished by patience and sand-paper.

§ xx. I shall only give one example, which however will show the reader what I mean, from the manufacture already alluded to, that of glass. Our modern glass is exquisitely clear in its substance, true in its form, accurate in its cutting. We are proud of this. We ought to be ashamed of it. The old Venice glass was muddy, inaccurate in all its forms, and clumsily cut, if at all. And the old Venetian was justly proud of it. For there is this difference between the English and Venetian workman, that the former thinks only of accurately matching his patterns, and getting his curves perfectly true and his edges perfectly sharp, and becomes a mere machine for rounding curves and sharpening edges, while the old Venetian cared not a whit whether his edges were sharp or not, but he invented a new design for every glass that he made, and never moulded a handle or a lip without a new fancy in it. And therefore, though some Venetian glass is ugly and clumsy

enough, when made by clumsy and uninventive workmen, other Venetian glass is so lovely in its forms that no price is too great for it; and we never see the same form in it twice. Now you cannot have the finish and the varied form too. If the workman is thinking about his edges, he cannot be thinking of his design; if of his design, he cannot think of his edges. Choose whether you will pay for the lovely form or the perfect finish, and choose at the same moment whether you will make the worker a man or a grindstone.

§ XXI. Nay, but the reader interrupts me,—“If the workman can design beautifully, I would not have him kept at the furnace. Let him be taken away and made a gentleman, and have a studio, and design his glass there, and I will have it blown and cut for him by common workmen, and so I will have my design and my finish too.”

All ideas of this kind are founded upon two mistaken suppositions: the first, that one man's thoughts can be, or ought to be, executed by another man's hands; the second, that manual labor is a degradation, when it is governed by intellect.

On a large scale, and in work determinable by line and rule, it is indeed both possible and necessary that the thoughts of one man should be carried out by the labor of others; in this sense I have already defined the best architecture to be the expression of the mind of manhood by the hands of childhood. But on a smaller scale, and in a design which cannot be mathematically defined, one man's thoughts can never be expressed by another: and the difference between the spirit of touch of the man who is inventing, and of the man who is obeying directions, is often all the difference between a great and a common work of art. How wide the separation is between original and second-hand execution, I shall endeavor to show elsewhere; it is not so much to our purpose here as to mark the other and more fatal error of despising manual labor when governed by intellect; for it is no less fatal an error to despise it when thus regulated by intellect, than to value it for its own sake. We are always in these days endeavoring to separate the two; we want one man to be always thinking, and another to be always working, and we call one a gentleman, and the

other an operative ; whereas the workman ought often to be thinking, and the thinker often to be working, and both should be gentlemen, in the best sense. As it is, we make both ungentle, the one envying, the other despising, his brother ; and the mass of society is made up of morbid thinkers, and miserable workers. Now it is only by labor that thought can be made healthy, and only by thought that labor can be made happy, and the two cannot be separated with impunity. It would be well if all of us were good handicraftsmen in some kind, and the dishonor of manual labor done away with altogether ; so that though there should still be a trenchant distinction of race between nobles and commoners, there should not, among the latter, be a trenchant distinction of employment, as between idle and working men, or between men of liberal and illiberal professions. All professions should be liberal, and there should be less pride felt in peculiarity of employment, and more in excellence of achievement. And yet more, in each several profession, no master should be too proud to do its hardest work. The painter should grind his own colors ; the architect work in the mason's yard with his men ; the master-manufacturer be himself a more skilful operative than any man in his mills ; and the distinction between one man and another be only in experience and skill, and the authority and wealth which these must naturally and justly obtain.

§ XXII. I should be led far from the matter in hand, if I were to pursue this interesting subject. Enough, I trust, has been said to show the reader that the rudeness or imperfection which at first rendered the term "Gothic" one of reproach is indeed, when rightly understood, one of the most noble characters of Christian architecture, and not only a noble but an *essential* one. It seems a fantastic paradox, but it is nevertheless a most important truth, that no architecture can be truly noble which is *not* imperfect. And this is easily demonstrable. For since the architect, whom we will suppose capable of doing all in perfection, cannot execute the whole with his own hands, he must either make slaves of his workmen in the old Greek, and present English fashion, and level

his work to a slave's capacities, which is to degrade it ; or else he must take his workmen as he finds them, and let them show their weaknesses together with their strength, which will involve the Gothic imperfection, but render the whole work as noble as the intellect of the age can make it.

§ xxiii. But the principle may be stated more broadly still. I have confined the illustration of it to architecture, but I must not leave it as if true of architecture only. Hitherto I have used the words imperfect and perfect merely to distinguish between work grossly unskilful, and work executed with average precision and science ; and I have been pleading that any degree of unskilfulness should be admitted, so only that the laborer's mind had room for expression. But, accurately speaking, no good work whatever can be perfect, and *the demand for perfection is always a sign of a misunderstanding of the ends of art.*

§ xxiv. This for two reasons, both based on everlasting laws. The first, that no great man ever stops working till he has reached his point of failure ; that is to say, his mind is always far in advance of his powers of execution, and the latter will now and then give way in trying to follow it ; besides that he will always give to the inferior portions of his work only such inferior attention as they require ; and according to his greatness he becomes so accustomed to the feeling of dissatisfaction with the best he can do, that in moments of lassitude or anger with himself he will not care though the beholder be dissatisfied also. I believe there has only been one man who would not acknowledge this necessity, and strove always to reach perfection, Leonardo ; the end of his vain effort being merely that he would take ten years to a picture, and leave it unfinished. And therefore, if we are to have great men working at all, or less men doing their best, the work will be imperfect, however beautiful. Of human work none but what is bad can be perfect, in its own bad way.*

* The Elgin marbles are supposed by many persons to be " perfect." In the most important portions they indeed approach perfection, but only there. The draperies are unfinished, the hair and wool of the animals are unfinished, and the entire bas-reliefs of the frieze are roughly cut.

§ xxv. The second reason is, that imperfection is in some sort essential to all that we know of life. It is the sign of life in a mortal body, that is to say, of a state of progress and change. Nothing that lives is, or can be, rigidly perfect; part of it is decaying, part nascent. The foxglove blossom,—a third part bud, a third part past, a third part in full bloom.—is a type of the life of this world. And in all things that live there are certain irregularities and deficiencies which are not only signs of life, but sources of beauty. No human face is exactly the same in its lines on each side, no leaf perfect in its lobes, no branch in its symmetry. All admit irregularity as they imply change; and to banish imperfection is to destroy expression, to check exertion, to paralyse vitality. All things are literally better, lovelier, and more beloved for the imperfections which have been divinely appointed, that the law of human life may be Effort, and the law of human judgment, Mercy.

Accept this then for a universal law, that neither architecture nor any other noble work of man can be good unless it be imperfect; and let us be prepared for the otherwise strange fact, which we shall discern clearly as we approach the period of the Renaissance, that the first cause of the fall of the arts of Europe was a relentless requirement of perfection, incapable alike either of being silenced by veneration for greatness, or softened into forgiveness of simplicity.

Thus far then of the Rudeness or Savageness, which is the first mental element of Gothic architecture. It is an element in many other healthy architectures also, as in Byzantine and Romanesque; but true Gothic cannot exist without it.

§ xxvi. The second mental element above named was CHANGEFULNESS, or Variety.

I have already enforced the allowing independent operation to the inferior workman, simply as a duty *to him*, and as ennobling the architecture by rendering it more Christian. We have now to consider what reward we obtain for the performance of this duty, namely, the perpetual variety of every feature of the building.

Wherever the workman is utterly enslaved, the parts of the

building must of course be absolutely like each other ; for the perfection of his execution can only be reached by exercising him in doing one thing, and giving him nothing else to do. The degree in which the workman is degraded may be thus known at a glance, by observing whether the several parts of the building are similar or not ; and if, as in Greek work, all the capitals are alike, and all the mouldings unvaried, then the degradation is complete ; if, as in Egyptian or Ninevite work, though the manner of executing certain figures is always the same, the order of design is perpetually varied, the degradation is less total ; if, as in Gothic work, there is perpetual change both in design and execution, the workman must have been altogether set free.

§ xxvii. How much the beholder gains from the liberty of the laborer may perhaps be questioned in England, where one of the strongest instincts in nearly every mind is that Love of Order which makes us desire that our house windows should pair like our carriage horses, and allows us to yield our faith unhesitatingly to architectural theories which fix a form for everything and forbid variation from it. I would not impeach love of order : it is one of the most useful elements of the English mind ; it helps us in our commerce and in all purely practical matters ; and it is in many cases one of the foundation stones of morality. Only do not let us suppose that love of order is love of art. It is true that order, in its highest sense, is one of the necessities of art, just as time is a necessity of music ; but love of order has no more to do with our right enjoyment of architecture or painting, than love of punctuality with the appreciation of an opera. Experience, I fear, teaches us that accurate and methodical habits in daily life are seldom characteristic of those who either quickly perceive, or richly possess, the creative powers of art ; there is, however, nothing inconsistent between the two instincts, and nothing to hinder us from retaining our business habits, and yet fully allowing and enjoying the noblest gifts of Invention. We already do so, in every other branch of art except architecture, and we only do *not* so there because we have been taught that it would be wrong. Our architects gravely inform us that, as there are

four rules of arithmetic, there are five orders of architecture, we, in our simplicity, think that this sounds consistent, and believe them. They inform us also that there is one proper form for Corinthian capitals, another for Doric, and another for Ionic. We, considering that there is also a proper form for the letters A, B, and C, think that this also sounds consistent, and accept the proposition. Understanding, therefore, that one form of the said capitals is proper, and no other, and having a conscientious horror of all impropriety, we allow the architect to provide us with the said capitals, of the proper form, in such and such a quantity, and in all other points to take care that the legal forms are observed; which having done, we rest in forced confidence that we are well housed.

§ xxviii. But our higher instincts are not deceived. We take no pleasure in the building provided for us, resembling that which we take in a new book or a new picture. We may be proud of its size, complacent in its correctness, and happy in its convenience. We may take the same pleasure in its symmetry and workmanship as in a well-ordered room, or a skilful piece of manufacture. And this we suppose to be all the pleasure that architecture was ever intended to give us. The idea of reading a building as we would read Milton or Dante, and getting the same kind of delight out of the stones as out of the stanzas, never enters our minds for a moment. And for good reason:—There is indeed rhythm in the verses, quite as strict as the symmetries or rhythm of the architecture, and a thousand times more beautiful, but there is something else than rhythm. The verses were neither made to order, nor to match, as the capitals were; and we have therefore a kind of pleasure in them other than a sense of propriety. But it requires a strong effort of common sense to shake ourselves quit of all that we have been taught for the last two centuries, and wake to the perception of a truth just as simple and certain as it is new: that great art, whether expressing itself in words, colors, or stones, does *not* say the same thing over and over again; that the merit of architectural, as of every other art, consists in its saying new and

different things; that to repeat itself is no more a characteristic of genius in marble than it is of genius in print; and that we may, without offending any laws of good taste, require of an architect, as we do of a novelist, that he should be not only correct, but entertaining.

Yet all this is true, and self-evident; only hidden from us, as many other self-evident things are, by false teaching. Nothing is a great work of art, for the production of which either rules or models can be given. Exactly so far as architecture works on known rules, and from given models, it is not an art, but a manufacture; and it is, of the two procedures, rather less rational (because more easy) to copy capitals or mouldings from Phidias, and call ourselves architects, than to copy heads and hands from Titian, and call ourselves painters.

§ xxix. Let us then understand at once, that change or variety is as much a necessity to the human heart and brain in buildings as in books; that there is no merit, though there is some occasional use, in monotony; and that we must no more expect to derive either pleasure or profit from an architecture whose ornaments are of one pattern, and whose pillars are of one proportion, than we should out of a universe in which the clouds were all of one shape, and the trees all of one size.

§ xxx. And this we confess in deeds, though not in words. All the pleasure which the people of the nineteenth century take in art, is in pictures, sculpture, minor objects of virtù, or mediæval architecture, which we enjoy under the term picturesque: no pleasure is taken anywhere in modern buildings, and we find all men of true feeling delighting to escape out of modern cities into natural scenery: hence, as I shall hereafter show, that peculiar love of landscape which is characteristic of the age. It would be well, if, in all other matters, we were as ready to put up with what we dislike, for the sake of compliance with established law, as we are in architecture.

§ xxxi. How so debased a law ever came to be established, we shall see when we come to describe the Renaissance schools: here we have only to note, as the second most essential element of the Gothic spirit, that it broke through that

law wherever it found it in existence ; it not only dared, but delighted in, the infringement of every servile principle ; and invented a series of forms of which the merit was, not merely that they were new, but that they were *capable of perpetual novelty*. The pointed arch was not merely a bold variation from the round, but it admitted of millions of variations in itself ; for the proportions of a pointed arch are changeable to infinity, while a circular arch is always the same. The grouped shaft was not merely a bold variation from the single one, but it admitted of millions of variations in its grouping, and in the proportions resultant from its grouping. The introduction of tracery was not only a startling change in the treatment of window lights, but admitted endless changes in the interlacement of the tracery bars themselves. So that, while in all living Christian architecture the love of variety exists, the Gothic schools exhibited that love in culminating energy ; and their influence, wherever it extended itself, may be sooner and farther traced by this character than by any other ; the tendency to the adoption of Gothic types being always first shown by greater irregularity and richer variation in the forms of the architecture it is about to supersede, long before the appearance of the pointed arch or of any other recognizable *outward* sign of the Gothic mind.

§ xxxii. We must, however, herein note carefully what distinction there is between a healthy and a diseased love of change ; for as it was in healthy love of change that the Gothic architecture rose, it was partly in consequence of diseased love of change that it was destroyed. In order to understand this clearly, it will be necessary to consider the different ways in which change and monotony are presented to us in nature ; both having their use, like darkness and light, and the one incapable of being enjoyed without the other : change being most delightful after some prolongation of monotony, as light appears most brilliant after the eyes have been for some time closed.

§ xxxiii. I believe that the true relations of monotony and change may be most simply understood by observing them in music. We may therein notice, first, that there is a sublimity

and majesty in monotony which there is not in rapid or frequent variation. This is true throughout all nature. The greater part of the sublimity of the sea depends on its monotony ; so also that of desolate moor and mountain scenery ; and especially the sublimity of motion, as in the quiet, unchanged fall and rise of an engine beam. So also there is sublimity in darkness which there is not in light.

§ xxxiv. Again, monotony after a certain time, or beyond a certain degree, becomes either uninteresting or intolerable, and the musician is obliged to break it in one or two ways : either while the air or passage is perpetually repeated, its notes are variously enriched and harmonized ; or else, after a certain number of repeated passages, an entirely new passage is introduced, which is more or less delightful according to the length of the previous monotony. Nature, of course, uses both these kinds of variation perpetually. The sea-waves, resembling each other in general mass, but none like its brother in minor divisions and curves, are a monotony of the first kind ; the great plain, broken by an emergent rock or clump of trees, is a monotony of the second.

§ xxxv. Farther : in order to the enjoyment of the change in either case, a certain degree of patience is required from the hearer or observer. In the first case, he must be satisfied to endure with patience the recurrence of the great masses of sound or form, and to seek for entertainment in a careful watchfulness of the minor details. In the second case, he must bear patiently the infliction of the monotony for some moments, in order to feel the full refreshment of the change. This is true even of the shortest musical passage in which the element of monotony is employed. In cases of more majestic monotony, the patience required is so considerable that it becomes a kind of pain,—a price paid for the future pleasure.

§ xxxvi. Again : the talent of the composer is not in the monotony, but in the changes : he may show feeling and taste by his use of monotony in certain places or degrees ; that is to say, by his *various* employment of it ; but it is always in the new arrangement or invention that his intellect is shown, and not in the monotony which relieves it.

Lastly : if the pleasure of change be too often repeated, it ceases to be delightful, for then change itself becomes monotonous, and we are driven to seek delight in extreme and fantastic degrees of it. This is the diseased love of change of which we have above spoken.

§ xxxvii. From these facts we may gather generally that monotony is, and ought to be, in itself painful to us, just as darkness is ; that an architecture which is altogether monotonous is a dark or dead architecture ; and, of those who love it, it may be truly said, “ they love darkness rather than light.” But monotony in certain measure, used in order to give value to change, and, above all, that *transparent* monotony which, like the shadows of a great painter, suffers all manner of dimly suggested form to be seen through the body of it, is an essential in architectural as in all other composition ; and the endurance of monotony has about the same place in a healthy mind that the endurance of darkness has : that is to say, as a strong intellect will have pleasure in the solemnities of storm and twilight, and in the broken and mysterious lights that gleam among them, rather than in mere brilliancy and glare, while a frivolous mind will dread the shadow and the storm ; and as a great man will be ready to endure much darkness of fortune in order to reach greater eminence of power or felicity, while an inferior man will not pay the price ; exactly in like manner a great mind will accept, or even delight in, monotony which would be wearisome to an inferior intellect, because it has more patience and power of expectation, and is ready to pay the full price for the great future pleasure of change. But in all cases it is not that the noble nature loves monotony, any more than it loves darkness or pain. But it can bear with it, and receives a high pleasure in the endurance or patience, a pleasure necessary to the well-being of this world ; while those who will not submit to the temporary sameness, but rush from one change to another, gradually dull the edge of change itself, and bring a shadow and weariness over the whole world from which there is no more escape.

§ xxxviii. From these general uses of variety in the economy of the world, we may at once understand its use and

abuse in architecture. The variety of the Gothic schools is the more healthy and beautiful, because in many cases it is entirely unstudied, and results, not from the mere love of change, but from practical necessities. For in one point of view Gothic is not only the best, but the *only rational* architecture, as being that which can fit itself most easily to all services, vulgar or noble. Undefined in its slope of roof, height of shaft, breadth of arch, or disposition of ground plan, it can shrink into a turret, expand into a hall, coil into a staircase, or spring into a spire, with undegraded grace and unexhausted energy; and whenever it finds occasion for change in its form or purpose, it submits to it without the slightest sense of loss either to its unity or majesty,—subtle and flexible like a fiery serpent, but ever attentive to the voice of the charmer. And it is one of the chief virtues of the Gothic builders, that they never suffered ideas of outside symmetries and consistencies to interfere with the real use and value of what they did. If they wanted a window, they opened one; a room, they added one; a buttress, they built one; utterly regardless of any established conventionalities of external appearance, knowing (as indeed it always happened) that such daring interruptions of the formal plan would rather give additional interest to its symmetry than injure it. So that, in the best times of Gothic, a useless window would rather have been opened in an unexpected place for the sake of the surprise, than a useful one forbidden for the sake of symmetry. Every successive architect, employed upon a great work, built the pieces he added in his own way, utterly regardless of the style adopted by his predecessors; and if two towers were raised in nominal correspondence at the sides of a cathedral front, one was nearly sure to be different from the other, and in each the style at the top to be different from the style at the bottom.*

§ xxxix. These marked variations were, however, only permitted as part of the great system of perpetual change which ran through every member of Gothic design, and rendered it

* In the eighth chapter we shall see a remarkable instance of this sacrifice of symmetry to convenience in the arrangement of the windows of the Ducal Palace.

as endless a field for the beholder's inquiry, as for the builder's imagination : change, which in the best schools is subtle and delicate, and rendered more delightful by intermingling of a noble monotony ; in the more barbaric schools is somewhat fantastic and redundant ; but, in all, a necessary and constant condition of the life of the school. Sometimes the variety is in one feature, sometimes in another ; it may be in the capitals or crockets, in the niches or the traceries, or in all together, but in some one or other of the features it will be found always. If the mouldings are constant, the surface sculpture will change ; if the capitals are of a fixed design, the traceries will change ; if the traceries are monotonous, the capitals will change ; and if even, as in some fine schools, the early English for example, there is the slightest approximation to an unvarying type of mouldings, capitals, and floral decoration, the variety is found in the disposition of the masses, and in the figure sculpture.

§ XL. I must now refer for a moment, before we quit the consideration of this, the second mental element of Gothic, to the opening of the third chapter of the "Seven Lamps of Architecture," in which the distinction was drawn (§ 2) between man gathering and man governing ; between his acceptance of the sources of delight from nature, and his developement of authoritative or imaginative power in their arrangement : for the two mental elements, not only of Gothic, but of all good architecture, which we have just been examining, belong to it, and are admirable in it, chiefly as it is, more than any other subject of art, the work of man, and the expression of the average power of man. A picture or poem is often little more than a feeble utterance of man's admiration of something out of himself ; but architecture approaches more to a creation of his own, born of his necessities, and expressive of his nature. It is also, in some sort, the work of the whole race, while the picture or statue are the work of one only, in most cases more highly gifted than his fellows. And therefore we may expect that the first two elements of good architecture should be expressive of some great truths commonly belonging to the whole race, and necessary to be understood or felt by them in all

their work that they do under the sun. And observe what they are : the confession of Imperfection and the confession of Desire of Change. The building of the bird and the bee needs not express anything like this. It is perfect and unchanging. But just because we are something better than birds or bees, our building must confess that we have not reached the perfection we can imagine, and cannot rest in the condition we have attained. If we pretend to have reached either perfection or satisfaction, we have degraded ourselves and our work. God's work only may express that ; but ours may never have that sentence written upon it,—“ And behold, it was very good.” And, observe again, it is not merely as it renders the edifice a book of various knowledge, or a mine of precious thought, that variety is essential to its nobleness. The vital principle is not the love of *Knowledge*, but the love of *Change*. It is that strange *disquietude* of the Gothic spirit that is its greatness ; that restlessness of the dreaming mind, that wanders hither and thither among the niches, and flickers feverishly around the pinnacles, and frets and fades in labyrinthine knots and shadows along wall and roof, and yet is not satisfied, nor shall be satisfied. The Greek could stay in his triglyph furrow, and be at peace ; but the work of the Gothic heart is fretwork still, and it can neither rest in, nor from, its labor, but must pass on, sleeplessly, until its love of change shall be pacified for ever in the change that must come alike on them that wake and them that sleep.

§ XLII. The third constituent element of the Gothic mind was stated to be NATURALISM ; that is to say, the love of natural objects for their own sake, and the effort to represent them frankly, unconstrained by artistical laws.

This characteristic of the style partly follows in necessary connexion with those named above. For, so soon as the workman is left free to represent what subjects he chooses, he must look to the nature that is round him for material, and will endeavor to represent it as he sees it, with more or less accuracy according to the skill he possesses, and with much play of fancy, but with small respect for law. There is, however, a marked distinction between the imaginations of

the Western and Eastern races, even when both are left free; the Western, or Gothic, delighting most in the representation of facts, and the Eastern (Arabian, Persian, and Chinese) in the harmony of colors and forms. Each of these intellectual dispositions has its particular forms of error and abuse, which, though I have often before stated, I must here again briefly explain; and this the rather, because the word Naturalism is, in one of its senses, justly used as a term of reproach, and the questions respecting the real relations of art and nature are so many and so confused throughout all the schools of Europe at this day, that I cannot clearly enunciate any single truth without appearing to admit, in fellowship with it, some kind of error, unless the reader will bear with me in entering into such an analysis of the subject as will serve us for general guidance.

§ XLII. We are to remember, in the first place, that the arrangement of colors and lines is an art analogous to the composition* of music, and entirely independent of the representation of facts. Good coloring does not necessarily convey the image of anything but itself. It consists in certain proportions and arrangements of rays of light, but not in likenesses to anything. A few touches of certain greys and purples laid by a master's hand on white paper, will be good coloring; as more touches are added beside them, we may find out that they were intended to represent a dove's neck, and we may praise, as the drawing advances, the perfect imi-

* I am always afraid to use this word "Composition;" it is so utterly misused in the general parlance respecting art. Nothing is more common than to hear divisions of art into "form, composition, and color," or "light and shade and composition," or "sentiment and composition," or it matters not what else and composition; the speakers in each case attaching a perfectly different meaning to the word, generally an indistinct one, and always a wrong one. Composition is, in plain English, "putting together," and it means the putting together of lines of forms, of colors, of shades, or of ideas. Painters compose in color, compose in thought, compose in form, and compose in effect: the word being of use merely in order to express a scientific, disciplined, and inventive arrangement of any of these, instead of a merely natural or accidental one.

tation of the dove's neck. But the good coloring does not consist in that imitation, but in the abstract qualities and relations of the grey and purple.

In like manner, as soon as a great sculptor begins to shape his work out of the block, we shall see that its lines are nobly arranged, and of noble character. We may not have the slightest idea for what the forms are intended, whether they are of man or beast, of vegetation or drapery. Their likeness to anything does not affect their nobleness. They are magnificent forms, and that is all we need care to know of them, in order to say whether the workman is a good or bad sculptor.

§ XLIII. Now the noblest art is an exact unison of the abstract value, with the imitative power, of forms and colors. It is the noblest composition, used to express the noblest facts. But the human mind cannot in general unite the two perfections: it either pursues the fact to the neglect of the composition, or pursues the composition to the neglect of the fact.

§ XLIV. And it is intended by the Deity that it *should* do this; the best art is not always wanted. Facts are often wanted without art, as in a geological diagram; and art often without facts, as in a Turkey carpet. And most men have been made capable of giving either one or the other, but not both; only one or two, the very highest, can give both.

Observe then. Men are universally divided, as respects their artistical qualifications, into three great classes; a right, a left, and a centre. On the right side are the men of facts, on the left the men of design,* in the centre the men of both.

The three classes of course pass into each other by imperceptible gradations. The men of facts are hardly ever altogether without powers of design; the men of design are always in some measure cognizant of facts; and as each class possesses more or less of the powers of the opposite one, it approaches to the character of the central class. Few men,

* Design is used in this place as expressive of the power to arrange lines and colors nobly. By facts, I mean facts perceived by the eye and mind, not facts accumulated by knowledge. See the chapter on Roman Renaissance (Vol. III. Chap. II.) for this distinction.

even in that central rank, are so exactly throned on the summit of the crest that they cannot be perceived to incline in the least one way or the other, embracing both horizons with their glance. Now each of these classes has, as I above said, a healthy function in the world, and correlative diseases or unhealthy functions; and, when the work of either of them is seen in its morbid condition, we are apt to find fault with the class of workmen, instead of finding fault only with the particular abuse which has perverted their action.

§ XLV. Let us first take an instance of the healthy action of the three classes on a simple subject, so as fully to understand the distinction between them, and then we shall more easily examine the corruptions to which they are liable. Fig. 1 in Plate VI. is a spray of vine with a bough of cherry-tree, which I have outlined from nature as accurately as I could, without in the least endeavoring to compose or arrange the form. It is a simple piece of fact-work, healthy and good as such, and useful to any one who wanted to know plain truths about tendrils of vines, but there is no attempt at design in it. Plate XIX., below, represents a branch of vine used to decorate the angle of the Ducal Palace. It is faithful as a representation of vine, and yet so designed that every leaf serves an architectural purpose, and could not be spared from its place without harm. This is central work; fact and design together. Fig. 2 in Plate VI. is a spandril from St. Mark's, in which the forms of the vine are dimly suggested, the object of the design being merely to obtain graceful lines and well proportioned masses upon the gold ground. There is not the least attempt to inform the spectator of any facts about the growth of the vine; there are no stalks or tendrils,—merely running bands with leaves emergent from them, of which nothing but the outline is taken from the vine, and even that imperfectly. This is design, unregardful of facts.

Now the work is, in all these three cases, perfectly healthy. Fig. 1 is not bad work because it has not design, nor Fig. 2 bad work because it has not facts. The object of the one is to give pleasure through truth, and of the other to give pleasure through composition. And both are right.

What, then, are the diseased operations to which the three classes of workmen are liable?

§ XLVI. Primarily, two; affecting the two inferior classes:

1st, When either of those two classes Despises the other;

2nd, When either of the two classes Envies the other; producing, therefore, four forms of dangerous error.

First, when the men of facts despise design. This is the error of the common Dutch painters, of merely imitative painters of still life, flowers, &c., and other men who, having either the gift of accurate imitation or strong sympathies with nature, suppose that all is done when the imitation is perfected or sympathy expressed. A large body of English landscapists come into this class, including most clever sketchers from nature, who fancy that to get a sky of true tone, and a gleam of sunshine or sweep of shower faithfully expressed, is all that can be required of art. These men are generally themselves answerable for much of their deadness of feeling to the higher qualities of composition. They probably have not originally the high gifts of design, but they lose such powers as they originally possessed by despising, and refusing to study, the results of great power of design in others. Their knowledge, as far as it goes, being accurate, they are usually presumptuous and self-conceited, and gradually become incapable of admiring anything but what is like their own works. They see nothing in the works of great designers but the faults, and do harm almost incalculable in the European society of the present day by sneering at the compositions of the greatest men of the earlier ages,* because they do not absolutely tally with their own ideas of "Nature."

§ XLVII. The second form of error is when the men of design despise facts. All noble design must deal with facts to a certain extent, for there is no food for it but in nature. The best colorist invents best by taking hints from natural colors; from birds, skies, or groups of figures. And if, in the delight of inventing fantastic color and form the truths of nature are

* "Earlier," that is to say, pre-Raphaelite ages. Men of this stamp will praise Claude, and such other comparatively debased artists; but they cannot taste the work of the thirteenth century.

wilfully neglected, the intellect becomes comparatively decrepit, and that state of art results which we find among the Chinese. The Greek designers delighted in the facts of the human form, and became great in consequence ; but the facts of lower nature were disregarded by them, and their inferior ornament became, therefore, dead and valueless.

§ XLVIII. The third form of error is when the men of facts envy design : that is to say, when, having only imitative powers, they refuse to employ those powers upon the visible world around them ; but, having been taught that composition is the end of art, strive to obtain the inventive powers which nature has denied them, study nothing but the works of reputed designers, and perish in a fungous growth of plagiarism and laws of art.

Here was the great error of the beginning of this century ; it is the error of the meanest kind of men that employ themselves in painting, and it is the most fatal of all, rendering those who fall into it utterly useless, incapable of helping the world with either truth or fancy, while, in all probability, they deceive it by base resemblances of both, until it hardly recognizes truth or fancy when they really exist.

§ XLIX. The fourth form of error is when the men of design envy facts ; that is to say, when the temptation of closely imitating nature leads them to forget their own proper ornamental function, and when they lose the power of the composition for the sake of graphic truth ; as, for instance, in the hawthorn moulding so often spoken of round the porch of Bourges Cathedral, which, though very lovely, might perhaps, as we saw above, have been better, if the old builder, in his excessive desire to make it look like hawthorn, had not painted it green.

§ L. It is, however, carefully to be noted, that the two morbid conditions to which the men of facts are liable are much more dangerous and harmful than those to which the men of design are liable. The morbid state of men of design injures themselves only ; that of the men of facts injures the whole world. The Chinese porcelain-painter is, indeed, not so great a man as he might be, but he does not want to break every-

thing that is not porcelain ; but the modern English fact-hunter, despising design, wants to destroy everything that does not agree with his own notions of truth, and becomes the most dangerous and despicable of iconoclasts, excited by egotism instead of religion. Again : the Bourges sculptor, painting his hawthorns green, did indeed somewhat hurt the effect of his own beautiful design, but did not prevent any one from loving hawthorn : but Sir George Beaumont, trying to make Constable paint grass brown *instead* of green, was setting himself between Constable and nature, blinding the painter, and blaspheming the work of God.

§ LI. So much, then, of the diseases of the inferior classes, caused by their envying or despising each other. It is evident that the men of the central class cannot be liable to any morbid operation of this kind, they possessing the powers of both.

But there is another order of diseases which affect all the three classes, considered with respect to their pursuit of facts. For observe, all the three classes are in some degree pursuers of facts ; even the men of design not being in any case altogether independent of external truth. Now, considering them *all* as more or less searchers after truth, there is another triple division to be made of them. Everything presented to them in nature has good and evil mingled in it : and artists, considered as searchers after truth, are again to be divided into three great classes, a right, a left, and a centre. Those on the right perceive, and pursue, the good, and leave the evil : those in the centre, the greatest, perceive and pursue the good and evil together, the whole thing as it verily is : those on the left perceive and pursue the evil, and leave the good.

§ LII. The first class, I say, take the good and leave the evil. Out of whatever is presented to them, they gather what it has of grace, and life, and light, and holiness, and leave all, or at least as much as possible, of the rest undrawn. The faces of their figures express no evil passions ; the skies of their landscapes are without storm ; the prevalent character of their color is brightness, and of their chiaroscuro fulness of light. The early Italian and Flemish painters, Angelico and

Hembling, Perugino, Francia, Raffaele in his best time, John Bellini, and our own Stothard, belong eminently to this class.

§ LIII. The second, or greatest class, render all that they see in nature unhesitatingly, with a kind of divine grasp and government of the whole, sympathizing with all the good, and yet confessing, permitting, and bringing good out of the evil also. Their subject is infinite as nature, their color equally balanced between splendor and sadness, reaching occasionally the highest degrees of both, and their chiaroscuro equally balanced between light and shade.

The principal men of this class are Michael Angelo, Leonardo, Giotto, Tintoret, and Turner. Raffaele in his second time, Titian, and Rubens are transitional; the first inclining to the eclectic, and the last two to the impure class, Raffaele rarely giving all the evil, Titian and Rubens rarely all the good.

§ LIV. The last class perceive and imitate evil only. They cannot draw the trunk of a tree without blasting and shattering it, nor a sky except covered with stormy clouds: they delight in the beggary and brutality of the human race; their color is for the most part subdued or lurid, and the greatest spaces of their pictures are occupied by darkness.

Happily the examples of this class are seldom seen in perfection. Salvator Rosa and Caravaggio are the most characteristic: the other men belonging to it approach towards the central rank by imperceptible gradations, as they perceive and represent more and more of good. But Murillo, Zurbaran, Camillo Procaccini, Rembrandt, and Teniers, all belong naturally to this lower class.

§ LV. Now, observe: the three classes into which artists were previously divided, of men of fact, men of design, and men of both, are all of Divine institution; but of these latter three, the last is in no wise of Divine institution. It is entirely human, and the men who belong to it have sunk into it by their own faults. They are, so far forth, either useless or harmful men. It is indeed good that evil should be occasionally represented, even in its worst forms, but never that it should be taken delight in: and the mighty men of the central

class will always give us all that is needful of it ; sometimes, as Hogarth did, dwelling upon it bitterly as satirists,—but this with the more effect, because they will neither exaggerate it, nor represent it mercilessly, and without the atoning points that all evil shows to a Divinely guided glance, even at its deepest. So then, though the third class will always, I fear, in some measure exist, the two necessary classes are only the first two ; and this is so far acknowledged by the general sense of men, that the basest class has been confounded with the second ; and painters have been divided commonly only into two ranks, now known, I believe, throughout Europe by the names which they first received in Italy, “ Puristi and Naturalisti.” Since, however, in the existing state of things, the degraded or evil-loving class, though less defined than that of the Puristi, is just as vast as it is indistinct, this division has done infinite dishonor to the great faithful painters of nature : and it has long been one of the objects I have had most at heart to show that, in reality, the Purists, in their sanctity, are less separated from these natural painters than the Sensualists in their foulness ; and that the difference, though less discernible, is in reality greater, between the man who pursues evil for its own sake, and him who bears with it for the sake of truth, than between this latter and the man who will not endure it at all.

§ LVI. Let us, then, endeavor briefly to mark the real relations of these three vast ranks of men, whom I shall call, for convenience in speaking of them, Purists, Naturalists, and Sensualists ; not that these terms express their real characters, but I know no word, and cannot coin a convenient one, which would accurately express the opposite of Purist ; and I keep the terms Purist and Naturalist in order to comply, as far as possible, with the established usage of language on the Continent. Now, observe : in saying that nearly everything presented to us in nature has mingling in it of good and evil, I do not mean that nature is conceivably improvable, or that anything that God has made could be called evil, if we could see far enough into its uses, but that, with respect to immediate effects or appearances, it may be so, just as the hard rind

or bitter kernel of a fruit may be an evil to the eater, though in the one is the protection of the fruit, and in the other its continuance. The Purist, therefore, does not mend nature, but receives from nature and from God that which is good for him ; while the Sensualist fills himself “with the husks that the swine did eat.”

The three classes may, therefore, be likened to men reaping wheat, of which the Purists take the fine flour, and the Sensualists the chaff and straw, but the Naturalists take all home, and make their cake of the one, and their couch of the other.

§ LVII. For instance. We know more certainly every day that whatever appears to us harmful in the universe has some beneficent or necessary operation ; that the storm which destroys a harvest brightens the sunbeams for harvests yet unsown, and that the volcano which buries a city preserves a thousand from destruction. But the evil is not for the time less fearful, because we have learned it to be necessary ; and we easily understand the timidity or the tenderness of the spirit which would withdraw itself from the presence of destruction, and create in its imagination a world of which the peace should be unbroken, in which the sky should not darken nor the sea rage, in which the leaf should not change nor the blossom wither. That man is greater, however, who contemplates with an equal mind the alternations of terror and of beauty ; who, not rejoicing less beneath the sunny sky, can bear also to watch the bars of twilight narrowing on the horizon ; and, not less sensible to the blessing of the peace of nature, can rejoice in the magnificence of the ordinances by which that peace is protected and secured. But separated from both by an immeasurable distance would be the man who delighted in convulsion and disease for their own sake ; who found his daily food in the disorder of nature mingled with the suffering of humanity ; and watched joyfully at the right hand of the Angel whose appointed work is to destroy as well as to accuse, while the corners of the House of feasting were struck by the wind from the wilderness.

§ LVIII. And far more is this true, when the subject of contemplation is humanity itself. The passions of mankind are

partly protective, partly beneficent, like the chaff and grain of the corn ; but none without their use, none without nobleness when seen in balanced unity with the rest of the spirit which they are charged to defend. The passions of which the end is the continuance of the race ; the indignation which is to arm it against injustice, or strengthen it to resist wanton injury ; and the fear * which lies at the root of prudence, reverence, and awe, are all honorable and beautiful, so long as man is regarded in his relations to the existing world. The religious Purist, striving to conceive him withdrawn from those relations, effaces from the countenance the traces of all transitory passion, illumines it with holy hope and love, and seals it with the serenity of heavenly peace ; he conceals the forms of the body by the deep-folded garment, or else represents them under severely chastened types, and would rather paint them emaciated by the fast, or pale from the torture, than strengthened by exertion, or flushed by emotion. But the great Naturalist takes the human being in its wholeness, in its mortal as well as its spiritual strength. Capable of sounding and sympathizing with the whole range of its passions, he brings one majestic harmony out of them all ; he represents it fearlessly in all its acts and thoughts, in its haste, its anger, its sensuality, and its pride, as well as in its fortitude or faith, but makes it noble in them all ; he casts aside the veil from the body, and beholds the mysteries of its form like an angel looking down on an inferior creature : there is nothing which he is reluctant to behold, nothing that he is ashamed to confess ; with all that lives, triumphing, falling, or suffering, he claims kindred, either in majesty or in mercy, yet standing, in a sort, afar off, unmoved even in the deepness of his sympathy ; for the spirit within him is too thoughtful to be grieved, too brave to be appalled, and too pure to be polluted.

§ LIX. How far beneath these two ranks of men shall we place, in the scale of being, those whose pleasure is only in sin or in suffering ; who habitually contemplate humanity in pov-

* Not selfish fear, caused by want of trust in God, or of resolution in the soul.

erty or decrepitude, fury or sensuality ; whose works are either temptations to its weakness, or triumphs over its ruin, and recognize no other subjects for thought or admiration than the subtlety of the robber, the rage of the soldier, or the joy of the Sybarite. It seems strange, when thus definitely stated, that such a school should exist. Yet consider a little what gaps and blanks would disfigure our gallery and chamber walls, in places that we have long approached with reverence, if every picture, every statue, were removed from them, of which the subject was either the vice or the misery of mankind, portrayed without any moral purpose : consider the innumerable groups having reference merely to various forms of passion, low or high ; drunken revels and brawls among peasants, gambling or fighting scenes among soldiers, amours and intrigues among every class, brutal battle pieces, banditti subjects, gluts of torture and death in famine, wreck, or slaughter, for the sake merely of the excitement,—that quickening and suppling of the dull spirit that cannot be gained for it but by bathing it in blood, afterward to wither back into stained and stiffened apathy ; and then that whole vast false heaven of sensual passion, full of nymphs, satyrs, graces, goddesses, and I know not what, from its high seventh circle in Correggio's Antiope, down to the Grecized ballet-dancers and smirking Cupids of the Parisian upholsterer. Sweep away all this, remorselessly, and see how much art we should have left.

§ LX. And yet these are only the grossest manifestations of the tendency of the school. There are subtler, yet not less certain, signs of it in the works of men who stand high in the world's list of sacred painters. I doubt not that the reader was surprised when I named Murillo among the men of this third rank. Yet, go into the Dulwich Gallery, and meditate for a little over that much celebrated picture of the two beggar boys, one eating lying on the ground, the other standing beside him. We have among our own painters one who cannot indeed be set beside Murillo as a painter of Madonnas, for he is a pure Naturalist, and, never having seen a Madonna, does not paint any ; but who, as a painter of beggar or peas-

ant boys, may be set beside Murillo, or any one else,—W. Hunt. He loves peasant boys, because he finds them more roughly and picturesquely dressed, and more healthily colored, than others. And he paints all that he sees in them fearlessly ; all the health and humor, and freshness, and vitality, together with such awkwardness and stupidity, and what else of negative or positive harm there may be in the creature ; but yet so that on the whole we love it, and find it perhaps even beautiful, or if not, at least we see that there is capability of good in it, rather than of evil ; and all is lighted up by a sunshine and sweet color that makes the smock-frock as precious as cloth of gold. But look at those two ragged and vicious vagrants that Murillo has gathered out of the street. You smile at first, because they are eating so naturally, and their roguery is so complete. But is there anything else than roguery there, or was it well for the painter to give his time to the painting of those repulsive and wicked children ? Do you feel moved with any charity towards children as you look at them ? Are we the least more likely to take any interest in ragged schools, or to help the next pauper child that comes in our way, because the painter has shown us a cunning beggar feeding greedily ? Mark the choice of the act. He might have shown hunger in other ways, and given interest to even this act of eating, by making the face wasted, or the eye wistful. But he did not care to do this. He delighted merely in the disgusting manner of eating, the food filling the cheek ; the boy is not hungry, else he would not turn round to talk and grin as he eats.

§ LXI. But observe another point in the lower figure. It lies so that the sole of the foot is turned towards the spectator ; not because it would have lain less easily in another attitude, but that the painter may draw, and exhibit, the grey dust engrained in the foot. Do not call this the painting of nature ; it is mere delight in foulness. The lesson, if there be any, in the picture, is not one whit the stronger. We all know that a beggar's bare foot cannot be clean ; there is no need to thrust its degradation into the light, as if no human imagination were vigorous enough for its conception.

§ LXII. The position of the Sensualists, in treatment of landscape, is less distinctly marked than in that of the figure : because even the wildest passions of nature are noble : but the inclination is manifested by carelessness in marking generic form in trees and flowers : by their preferring confused and irregular arrangements of foliage or foreground to symmetrical and simple grouping ; by their general choice of such picturesqueness as results from decay, disorder, and disease, rather than of that which is consistent with the perfection of the things in which it is found ; and by their imperfect rendering of the elements of strength and beauty in all things. I propose to work out this subject fully in the last volume of "Modern Painters ;" but I trust that enough has been here said to enable the reader to understand the relations of the three great classes of artists, and therefore also the kinds of morbid condition into which the two higher (for the last has no other than a morbid condition) are liable to fall. For, since the function of the Naturalists is to represent, as far as may be, the whole of nature, and the Purists to represent what is absolutely good for some special purpose or time, it is evident that both are liable to error from shortness of sight, and the last also from weakness of judgment. I say, in the first place, both may err from shortness of sight, from not seeing all that there is in nature ; seeing only the outsides of things, or those points of them which bear least on the matter in hand. For instance, a modern continental Naturalist sees the anatomy of a limb thoroughly, but does not see its color against the sky, which latter fact is to a painter far the more important of the two. And because it is always easier to see the surface than the depth of things, the full sight of them requiring the highest powers of penetration, sympathy, and imagination, the world is full of vulgar Naturalists : not Sensualists, observe, not men who delight in evil ; but men who never see the deepest good, and who bring discredit on all painting of Nature by the little that they discover in her. And the Purist, besides being liable to this same shortsightedness, is liable also to fatal errors of judgment ; for he may think that good which is not so, and that the highest good which is the least. And

thus the world is full of vulgar Purists,* who bring discredit on all selection by the silliness of their choice ; and this the more, because the very becoming a Purist is commonly indicative of some slight degree of weakness, readiness to be offended, or narrowness of understanding of the ends of things : the greatest men being, in all times of art, Naturalists, without any exception ; and the greatest Purists being those who approach nearest to the Naturalists, as Benozzo Gozzoli and Perugino. Hence there is a tendency in the Naturalists to despise the Purists, and in the Purists to be offended with the Naturalists (not understanding them, and confounding them with the Sensualists) ; and this is grievously harmful to both.

§ LXIII. Of the various forms of resultant mischief it is not here the place to speak : the reader may already be somewhat wearied with a statement which has led us apparently so far from our immediate subject. But the digression was necessary, in order that I might clearly define the sense in which I use the word Naturalism when I state it to be the third most essential characteristic of Gothic architecture. I mean that the Gothic builders belong to the central or greatest rank in *both* the classifications of artists which we have just made ;

* I reserve for another place the full discussion of this interesting subject, which here would have led me too far ; but it must be noted, in passing, that this vulgar Purism, which rejects truth, not because it is vicious, but because it is humble, and consists not in choosing what is good, but in disguising what is rough, extends itself into every species of art. The most definite instance of it is the dressing of characters of peasantry in an opera or ballet scene ; and the walls of our exhibitions are full of works of art which “exalt nature” in the same way, not by revealing what is great in the heart, but by smoothing what is coarse in the complexion. There is nothing, I believe, so vulgar, so hopeless, so indicative of an irretrievably base mind, as this species of Purism. Of healthy Purism carried to the utmost endurable length in this direction, exalting the heart first, and the features with it, perhaps the most characteristic instance I can give is Stothard’s vignette to “Jorasse,” in Rogers’s Italy ; at least it would be so if it could be seen beside a real group of Swiss girls. The poems of Rogers, compared with those of Crabbe, are admirable instances of the healthiest Purism and healthiest Naturalism in poetry. The first great Naturalists of Christian art were Orcagna and Giotto.

that, considering all artists as either men of design, men of facts, or men of both, the Gothic builders were men of both ; and that again, considering all artists as either Purists, Naturalists, or Sensualists, the Gothic builders were Naturalists.

§ LXIV. I say first, that the Gothic builders were of that central class which unites fact with design ; but that the part of the work which was more especially their own was the truthfulness. Their power of artistical invention or arrangement was not greater than that of Romanesque and Byzantine workmen : by those workmen they were taught the principles, and from them received their models, of design ; but to the ornamental feeling and rich fancy of the Byzantine the Gothic builder added a love of *fact* which is never found in the South. Both Greek and Roman used conventional foliage in their ornament, passing into something that was not foliage at all, knotting itself into strange cup-like buds or clusters, and growing out of lifeless rods instead of stems ; the Gothic sculptor received these types, at first, as things that ought to be, just as we have a second time received them ; but he could not rest in them. He saw there was no veracity in them, no knowledge, no vitality. Do what he would, he could not help liking the true leaves better ; and cautiously, a little at a time, he put more of nature into his work, until at last it was all true, retaining, nevertheless, every valuable character of the original well-disciplined and designed arrangement.*

§ LXV. Nor is it only in external and visible subject that the Gothic workman wrought for truth : he is as firm in his rendering of imaginative as of actual truth ; that is to say, when an idea would have been by a Roman, or Byzantine, symbolically represented, the Gothic mind realizes it to the utmost. For instance, the purgatorial fire is represented in the mosaic of Torcelló (Romanesque) as a red stream, longitudinally striped like a riband, descending out of the throne of Christ, and gradually extending itself to envelope the wicked. When we are once informed what this means, it is enough for

* The reader will understand this in a moment by glancing at Plate XX., the last in this volume, where the series 1 to 12 represents the change in one kind of leaf, from the Byzantine to the perfect Gothic.

its purpose ; but the Gothic inventor does not leave the sign in need of interpretation. He makes the fire as like real fire as he can ; and in the porch of St. Maclou at Rouen the sculptured flames burst out of the Hades gate, and flicker up, in writhing tongues of stone, through the interstices of the niches, as if the church itself were on fire. This is an extreme instance, but it is all the more illustrative of the entire difference in temper and thought between the two schools of art, and of the intense love of veracity which influenced the Gothic design.

§ LXVI. I do not say that this love of veracity is always healthy in its operation. I have above noticed the errors into which it falls from despising design ; and there is another kind of error noticeable in the instance just given, in which the love of truth is too hasty, and seizes on a surface truth instead of an inner one. For in representing the Hades fire, it is not the mere *form* of the flame which needs most to be told, but its unquenchableness, its Divine ordainment and limitation, and its inner fierceness, not physical and material, but in being the expression of the wrath of God. And these things are not to be told by imitating the fire that flashes out of a bundle of sticks. If we think over his symbol a little, we shall perhaps find that the Romanesque builder told more truth in that likeness of a blood-red stream, flowing between definite shores and out of God's throne, and expanding, as if fed by a perpetual current, into the lake wherein the wicked are cast, than the Gothic builder in those torch-flickerings about his niches. But this is not to our immediate purpose ; I am not at present to insist upon the faults into which the love of truth was led in the later Gothic times, but on the feeling itself, as a glorious and peculiar characteristic of the Northern builders. For, observe, it is not, even in the above instance, love of truth, but want of thought, which *causes* the fault. The love of truth, as such, is good, but when it is misdirected by thoughtlessness or over-excited by vanity, and either seizes on facts of small value, or gathers them chiefly that it may boast of its grasp and apprehension, its work may well become dull or offensive. Yet let us not, therefore, blame the inherent love of facts, but

the incautiousness of their selection, and impertinence of their statement.

§ LXVII. I said, in the second place, that Gothic work, when referred to the arrangement of all art, as purist, naturalist, or sensualist, was naturalist. This character follows necessarily on its extreme love of truth, prevailing over the sense of beauty, and causing it to take delight in portraiture of every kind, and to express the various characters of the human countenance and form, as it did the varieties of leaves and the ruggedness of branches. And this tendency is both increased and ennobled by the same Christian humility which we saw expressed in the first character of Gothic work, its rudeness. For as that resulted from a humility which confessed the imperfection of the *workman*, so this naturalist portraiture is rendered more faithful by the humility which confesses the imperfection of the *subject*. The Greek sculptor could neither bear to confess his own feebleness, nor to tell the faults of the forms that he portrayed. But the Christian workman, believing that all is finally to work together for good, freely confesses both, and neither seeks to disguise his own roughness of work, nor his subject's roughness of make. Yet this frankness being joined, for the most part, with depth of religious feeling in other directions, and especially with charity, there is sometimes a tendency to Purism in the best Gothic sculpture; so that it frequently reaches great dignity of form and tenderness of expression, yet never so as to lose the veracity of portraiture, wherever portraiture is possible: not exalting its kings into demi-gods, nor its saints into archangels, but giving what kingliness and sanctity was in them, to the full, mixed with due record of their faults; and this in the most part with a great indifference like that of Scripture history, which sets down, with unmoved and unexcusing resoluteness, the virtues and errors of all men of whom it speaks, often leaving the reader to form his own estimate of them, without an indication of the judgment of the historian. And this veracity is carried out by the Gothic sculptors in the minuteness and generality, as well as the equity, of their delineation: for they do not limit their art to the portraiture of saints and kings, but introduce the

most familiar scenes and most simple subjects ; filling up the backgrounds of Scripture histories with vivid and curious representations of the commonest incidents of daily life, and availing themselves of every occasion in which, either as a symbol, or an explanation of a scene or time, the things familiar to the eye of the workman could be introduced and made of account. Hence Gothic sculpture and painting are not only full of valuable portraiture of the greatest men, but copious records of all the domestic customs and inferior arts of the ages in which it flourished.*

§ LXVIII. There is, however, one direction in which the Naturalism of the Gothic workmen is peculiarly manifested ; and this direction is even more characteristic of the school than the Naturalism itself ; I mean their peculiar fondness for the forms of Vegetation. In rendering the various circumstances of daily life, Egyptian and Ninevite sculpture is as frank and as diffuse as the Gothic. From the highest pomps of state or triumphs of battle, to the most trivial domestic arts and amusements, all is taken advantage of to fill the field of granite with the perpetual interest of a crowded drama ; and the early Lombardic and Romanesque sculpture is equally copious in its description of the familiar circumstances of war and the chase. But in all the scenes portrayed by the workmen of these nations, vegetation occurs only as an explanatory accessory ; the reed is introduced to mark the course of the river, or the tree to mark the covert of the wild beast, or the ambush of the enemy, but there is no especial interest in the forms of the vegetation strong enough to induce them to make it a subject of separate and accurate study. Again, among the nations who followed the arts of design exclusively, the forms of foliage introduced were

* The best art either represents the facts of its own day, or, if facts of the past, expresses them with accessories of the time in which the work was done. All good art, representing past events, is therefore full of the most frank anachronism, and always *ought* to be. No painter has any business to be an antiquarian. We do not want his impressions or suppositions respecting things that are past. We want his clear assertions respecting things present.

meagre and general, and their real intricacy and life were neither admired nor expressed. But to the Gothic workman the living foliage became a subject of intense affection, and he struggled to render all its characters with as much accuracy as was compatible with the laws of his design and the nature of his material, not unfrequently tempted in his enthusiasm to transgress the one and disguise the other.

§ LXIX. There is a peculiar significancy in this, indicative both of higher civilization and gentler temperament, than had before been manifested in architecture. Rudeness, and the love of change, which we have insisted upon as the first elements of Gothic, are also elements common to all healthy schools. But here is a softer element mingled with them, peculiar to the Gothic itself. The rudeness or ignorance which would have been painfully exposed in the treatment of the human form, are still not so great as to prevent the successful rendering of the wayside herbage; and the love of change, which becomes morbid and feverish in following the haste of the hunter, and the rage of the combatant, is at once soothed and satisfied as it watches the wandering of the tendril, and the budding of the flower. Nor is this all: the new direction of mental interest marks an infinite change in the means and the habits of life. The nations whose chief support was in the chase, whose chief interest was in the battle, whose chief pleasure was in the banquet, would take small care respecting the shapes of leaves and flowers; and notice little in the forms of the forest trees which sheltered them, except the signs indicative of the wood which would make the toughest lance, the closest roof, or the clearest fire. The affectionate observation of the grace and outward character of vegetation is the sure sign of a more tranquil and gentle existence, sustained by the gifts, and gladdened by the splendor, of the earth. In that careful distinction of species, and richness of delicate and undisturbed organization, which characterize the Gothic design, there is the history of rural and thoughtful life, influenced by habitual tenderness, and devoted to subtle inquiry; and every discriminating and delicate touch of the chisel, as it rounds the petal or guides the

branch, is a prophecy of the developement of the entire body of the natural sciences, beginning with that of medicine, of the recovery of literature, and the establishment of the most necessary principles of domestic wisdom and national peace.

§ LXX. I have before alluded to the strange and vain supposition, that the original conception of Gothic architecture had been derived from vegetation,—from the symmetry of avenues, and the interlacing of branches. It is a supposition which never could have existed for a moment in the mind of any person acquainted with early Gothic; but, however idle as a theory, it is most valuable as a testimony to the character of the perfected style. It is precisely because the reverse of this theory is the fact, because the Gothic did not arise out of, but develope itself into, a resemblance to vegetation, that this resemblance is so instructive as an indication of the temper of the builders. It was no chance suggestion of the form of an arch from the bending of a bough, but a gradual and continual discovery of a beauty in natural forms which could be more and more perfectly transferred into those of stone, that influenced at once the heart of the people, and the form of the edifice. The Gothic architecture arose in massy and mountainous strength, axe-hewn, and iron-bound, block heaved upon block by the monk's enthusiasm and the soldier's force; and cramped and stanchioned into such weight of grisly wall, as might bury the anchoret in darkness, and beat back the utmost storm of battle, suffering but by the same narrow crosslet the passing of the sunbeam, or of the arrow. Gradually, as that monkish enthusiasm became more thoughtful, and as the sound of war became more and more intermittent beyond the gates of the convent or the keep, the stony pillar grew slender and the vaulted roof grew light, till they had wreathed themselves into the semblance of the summer woods at their fairest, and of the dead field-flowers, long trodden down in blood, sweet monumental statues were set to bloom for ever, beneath the porch of the temple, or the canopy of the tomb.

§ LXXI. Nor is it only as a sign of greater gentleness or refinement of mind, but as a proof of the best possible direction

of this refinement, that the tendency of the Gothic to the expression of vegetative life is to be admired. That sentence of Genesis, "I have given thee every green herb for meat," like all the rest of the book, has a profound symbolical as well as a literal meaning. It is not merely the nourishment of the body, but the food of the soul, that is intended. The green herb is, of all nature, that which is most essential to the healthy spiritual life of man. Most of us do not need fine scenery; the precipice and the mountain peak are not intended to be seen by all men,—perhaps their power is greatest over those who are unaccustomed to them. But trees, and fields, and flowers were made for all, and are necessary for all. God has connected the labor which is essential to the bodily sustenance, with the pleasures which are healthiest for the heart; and while He made the ground stubborn, He made its herbage fragrant, and its blossoms fair. The proudest architecture that man can build has no higher honor than to bear the image and recall the memory of that grass of the field which is, at once, the type and the support of his existence; the goodly building is then most glorious when it is sculptured into the likeness of the leaves of Paradise; and the great Gothic spirit, as we showed it to be noble in its inquietude, is also noble in its hold of nature; it is, indeed, like the dove of Noah, in that she found no rest upon the face of the waters,—but like her in this also, "LO, IN HER MOUTH WAS AN OLIVE BRANCH, PLUCKED OFF."

§ LXXII. The fourth essential element of the Gothic mind was above stated to be the sense of the GROTESQUE; but I shall defer the endeavor to define this most curious and subtle character until we have occasion to examine one of the divisions of the Renaissance schools, which was morbidly influenced by it (Vol. III. Chap. III.). It is the less necessary to insist upon it here, because every reader familiar with Gothic architecture must understand what I mean, and will, I believe, have no hesitation in admitting that the tendency to delight in fantastic and ludicrous, as well as in sublime, images, is a universal instinct of the Gothic imagination.

§ LXXIII. The fifth element above named was RIGIDITY; and

this character I must endeavor carefully to define, for neither the word I have used, nor any other that I can think of, will express it accurately. For I mean, not merely stable, but *active* rigidity; the peculiar energy which gives tension to movement, and stiffness to resistance, which makes the fiercest lightning forked rather than curved, and the stoutest oak-branch angular rather than bending, and is as much seen in the quivering of the lance as in the glittering of the icicle.

§ LXXIV. I have before had occasion (Vol. I. Chap. XIII. § VII.) to note some manifestations of this energy or fixedness; but it must be still more attentively considered here, as it shows itself throughout the whole structure and decoration of Gothic work. Egyptian and Greek buildings stand, for the most part, by their own weight and mass, one stone passively incumbent on another: but in the Gothic vaults and traceries there is a stiffness analogous to that of the bones of a limb, or fibres of a tree; an elastic tension and communication of force from part to part, and also a studious expression of this throughout every visible line of the building. And, in like manner, the Greek and Egyptian ornament is either mere surface engraving, as if the face of the wall had been stamped with a seal, or its lines are flowing, lithe, and luxuriant; in either case, there is no expression of energy in framework of the ornament itself. But the Gothic ornament stands out in prickly independence, and frosty fortitude, jutting into crockets, and freezing into pinnacles; here starting up into a monster, there germinating into a blossom; anon knitting itself into a branch, alternately thorny, bossy, and bristly, or writhed into every form of nervous entanglement; but, even when most graceful, never for an instant languid, always quickset; erring, if at all, ever on the side of brusquerie.

§ LXXV. The feelings or habits in the workman which give rise to this character in the work, are more complicated and various than those indicated by any other sculptural expression hitherto named. There is, first, the habit of hard and rapid working; the industry of the tribes of the North, quickened by the coldness of the climate, and giving an expression of sharp energy to all they do (as above noted, Vol. I.

Chap. XIII. § VII.), as opposed to the languor of the Southern tribes, however much of fire there may be in the heart of that languor, for lava itself may flow languidly. There is also the habit of finding enjoyment in the signs of cold, which is never found, I believe, in the inhabitants of countries south of the Alps. Cold is to them an unredeemed evil, to be suffered, and forgotten as soon as may be ; but the long winter of the North forces the Goth (I mean the Englishman, Frenchman, Dane, or German), if he would lead a happy life at all, to find sources of happiness in foul weather as well as fair, and to rejoice in the leafless as well as in the shady forest. And this we do with all our hearts ; finding perhaps nearly as much contentment by the Christmas fire as in the summer sunshine, and gaining health and strength on the ice-fields of winter, as well as among the meadows of spring. So that there is nothing adverse or painful to our feelings in the cramped and stiffened structure of vegetation checked by cold ; and instead of seeking, like the Southern sculptor, to express only the softness of leafage nourished in all tenderness, and tempted into all luxuriance by warm winds and glowing rays, we find pleasure in dwelling upon the crabbed, perverse, and morose animation of plants that have known little kindness from earth or heaven, but, season after season, have had their best efforts palsied by frost, their brightest buds buried under snow, and their goodliest limbs lopped by tempest.

§ LXXVI. There are many subtle sympathies and affections which join to confirm the Gothic mind in this peculiar choice of subject ; and when we add to the influence of these, the necessities consequent upon the employment of a rougher material, compelling the workman to seek for vigor of effect, rather than refinement of texture or accuracy of form, we have direct and manifest causes for much of the difference between the northern and southern cast of conception : but there are indirect causes holding a far more important place in the Gothic heart, though less immediate in their influence on design. Strength of will, independence of character, resoluteness of purpose, impatience of undue control, and that general tendency to set the individual reason against authority,

and the individual deed against destiny, which, in the Northern tribes, has opposed itself throughout all ages to the languid submission, in the Southern, of thought to tradition, and purpose to fatality, are all more or less traceable in the rigid lines, vigorous and various masses, and daringly projecting and independent structure of the Northern Gothic ornament : while the opposite feelings are in like manner legible in the graceful and softly guided waves and wreathed bands, in which Southern decoration is constantly disposed ; in its tendency to lose its independence, and fuse itself into the surface of the masses upon which it is traced ; and in the expression seen so often, in the arrangement of those masses themselves, of an abandonment of their strength to an inevitable necessity, or a listless repose.

§ LXXVII. There is virtue in the measure, and error in the excess, of both these characters of mind, and in both of the styles which they have created ; the best architecture, and the best temper, are those which unite them both ; and this fifth impulse of the Gothic heart is therefore that which needs most caution in its indulgence. It is more definitely Gothic than any other, but the best Gothic building is not that which is *most* Gothic : it can hardly be too frank in its confession of rudeness, hardly too rich in its changefulness, hardly too faithful in its naturalism ; but it may go too far in its rigidity, and, like the great Puritan spirit in its extreme, lose itself either in frivolity of division, or perversity of purpose.* It actually did so in its later times ; but it is gladdening to remember that in its utmost nobleness, the very temper which has been thought most adverse to it, the Protestant spirit of self-dependence and inquiry, was expressed in its every line. Faith and aspiration there were, in every Christian ecclesiastical building, from the first century to the fifteenth ; but the

* See the account of the meeting at Talla Linns, in 1682, given in the fourth chapter of the "Heart of Midlothian." At length they arrived at the conclusion that "they who owned (or allowed) such names as Monday, Tuesday, January, February, and so forth, served themselves heirs to the same if not greater punishment than had been denounced against the idolaters of old."

moral habits to which England in this age owes the kind of greatness that she has,—the habits of philosophical investigation, of accurate thought, of domestic seclusion and independence, of stern self-reliance, and sincere upright searching into religious truth,—were only traceable in the features which were the distinctive creation of the Gothic schools, in the veined foliage, and thorny fret-work, and shadowy niche, and buttressed pier, and fearless height of subtle pinnacle and crested tower, sent like an “unperplexed question up to Heaven.”*

§ LXXVIII. Last, because the least essential, of the constituent elements of this noble school, was placed that of REDUNDANCE,—the uncalculating bestowal of the wealth of its labor. There is, indeed, much Gothic, and that of the best period, in which this element is hardly traceable, and which depends for its effect almost exclusively on loveliness of simple design and grace of uninvolved proportion: still, in the most characteristic buildings, a certain portion of their effect depends upon accumulation of ornament; and many of those which have most influence on the minds of men, have attained it by means of this attribute alone. And although, by careful study of the school, it is possible to arrive at a condition of taste which shall be better contented by a few perfect lines than by a whole façade covered with fretwork, the building which only satisfies such a taste is not to be considered the best. For the very first requirement of Gothic architecture being, as we saw above, that it shall both admit the aid, and appeal to the admiration, of the rudest as well as the most refined minds, the richness of the work is, paradoxical as the statement may appear, a part of its humility. No architecture is so haughty as that which is simple; which refuses to address the eye, except in a few clear and forceful lines; which implies, in offering so little to our regards, that all it has offered is perfect; and disdains, either by the complexity or the attractiveness of its feat-

* See the beautiful description of Florence in Elizabeth Browning's “Casa Guidi Windows,” which is not only a noble poem, but the only book I have seen which, favoring the Liberal cause in Italy, gives a just account of the incapacities of the modern Italian.

ures, to embarrass our investigation, or betray us into delight. That humility, which is the very life of the Gothic school, is shown not only in the imperfection, but in the accumulation, of ornament. The inferior rank of the workman is often shown as much in the richness, as the roughness, of his work ; and if the co-operation of every hand, and the sympathy of every heart, are to be received, we must be content to allow the redundance which disguises the failure of the feeble, and wins the regard of the inattentive. There are, however, far nobler interests mingling, in the Gothic heart, with the rude love of decorative accumulation : a magnificent enthusiasm, which feels as if it never could do enough to reach the fulness of its ideal ; an unselfishness of sacrifice, which would rather cast fruitless labor before the altar than stand idle in the market ; and, finally, a profound sympathy with the fulness and wealth of the material universe, rising out of that Naturalism whose operation we have already endeavored to define. The sculptor who sought for his models among the forest leaves, could not but quickly and deeply feel that complexity need not involve the loss of grace, nor richness that of repose ; and every hour which he spent in the study of the minute and various work of Nature, made him feel more forcibly the barrenness of what was best in that of man : nor is it to be wondered at, that, seeing her perfect and exquisite creations poured forth in a profusion which conception could not grasp nor calculation sum, he should think that it ill became him to be niggardly of his own rude craftsmanship ; and where he saw throughout the universe a faultless beauty lavished on measureless spaces of brodered field and blooming mountain, to grudge his poor and imperfect labor to the few stones that he had raised one upon another, for habitation or memorial. The years of his life passed away before his task was accomplished ; but generation succeeded generation with unwearied enthusiasm, and the cathedral front was at last lost in the tapestry of its traceries, like a rock among the thickets and herbage of spring.

§ LXXIX. We have now, I believe, obtained a view approaching to completeness of the various moral or imaginative ele-

ments which composed the inner spirit of Gothic architecture. We have, in the second place, to define its outward form.

Now, as the Gothic spirit is made up of several elements, some of which may, in particular examples, be wanting, so the Gothic form is made up of minor conditions of form, some of which may, in particular examples, be imperfectly developed.

We cannot say, therefore, that a building is either Gothic or not Gothic in form, any more than we can in spirit. We can only say that it is more or less Gothic, in proportion to the number of Gothic forms which it unites.

§ LXXX. There have been made lately many subtle and ingenious endeavors to base the definition of Gothic form entirely upon the roof-vaulting; endeavors which are both forced and futile: for many of the best Gothic buildings in the world have roofs of timber, which have no more connection with the main structure of the walls of the edifice than a hat has with that of the head it protects; and other Gothic buildings are merely enclosures of spaces, as ramparts and walls, or enclosures of gardens or cloisters, and have no roofs at all, in the sense in which the word "roof" is commonly accepted. But every reader who has ever taken the slightest interest in architecture must know that there is a great popular impression on this matter, which maintains itself stiffly in its old form, in spite of all ratiocination and definition; namely, that a flat lintel from pillar to pillar is Grecian, a round arch Norman or Romanesque, and a pointed arch Gothic.

And the old popular notion, as far as it goes, is perfectly right, and can never be bettered. The most striking outward feature in all Gothic architecture is, that it is composed of pointed arches, as in Romanesque that it is in like manner composed of round; and this distinction would be quite as clear, though the roofs were taken off every cathedral in Europe. And yet, if we examine carefully into the real force and meaning of the term "roof" we shall perhaps be able to retain the old popular idea in a definition of Gothic architecture which shall also express whatever dependence that architecture has upon true forms of roofing.

§ LXXXI. In Chap. XIII. of the first volume, the reader will remember that roofs were considered as generally divided into two parts; the roof proper, that is to say, the shell, vault, or ceiling, internally visible; and the roof-mask, which protects this lower roof from the weather. In some buildings these parts are united in one framework; but, in most, they are more or less independent of each other, and in nearly all Gothic buildings there is considerable interval between them.

Now it will often happen, as above noticed, that owing to the nature of the apartments required, or the materials at hand, the roof proper may be flat, coved, or domed, in buildings which in their walls employ pointed arches, and are, in the strictest sense of the word, Gothic in all other respects. Yet so far forth as the roofing alone is concerned, they are not Gothic unless the pointed arch be the principal form adopted either in the stone vaulting or the timbers of the roof proper.

I shall say then, in the first place, that "Gothic architecture is that which uses, if possible, the pointed arch in the roof proper." This is the first step in our definition.

§ LXXXII. Secondly. Although there may be many advisable or necessary forms for the lower roof or ceiling, there is, in cold countries exposed to rain and snow, only one advisable form for the roof-mask, and that is the gable, for this alone will throw off both rain and snow from all parts of its surface as speedily as possible. Snow can lodge on the top of a dome, not on the ridge of a gable. And thus, as far as roofing is concerned, the gable is a far more essential feature of Northern architecture than the pointed vault, for the one is a thorough necessity, the other often a graceful conventionality: the gable occurs in the timber roof of every dwelling-house and every cottage, but not the vault; and the gable built on a polygonal or circular plan, is the origin of the turret and spire;* and all the so-called aspiration of Gothic architecture is, as above noticed (Vol. I. Chap. XII. § vi.), nothing more than its de-

* Salisbury spire is only a tower with a polygonal gabled roof of stone. and so also the celebrated spires of Caen and Coutances.

velopment. So that we must add to our definition another clause, which will be, at present, by far the most important, and it will stand thus: "Gothic architecture is that which uses the pointed arch for the roof proper, and the gable for the roof-mask."

§ LXXXIII. And here, in passing, let us notice a principle as true in architecture as in morals. It is not the *compelled*, but the *wilful*, transgression of law which corrupts the character. Sin is not in the act, but in the choice. It is a law for Gothic architecture, that it shall use the pointed arch for its roof proper; but because, in many cases of domestic building, this becomes impossible for want of room (the whole height of the apartment being required everywhere), or in various other ways inconvenient, flat ceilings may be used, and yet the Gothic shall not lose its purity. But in the roof-mask, there can be no necessity nor reason for a change of form: the gable is the best; and if any other—dome, or bulging crown, or whatsoever else—be employed at all, it must be in pure caprice, and wilful transgression of law. And wherever, therefore, this is done, the Gothic has lost its character; it is pure Gothic no more.

§ LXXXIV. And this last clause of the definition is to be more strongly insisted upon, because it includes multitudes of buildings, especially domestic, which are Gothic in spirit, but which we are not in the habit of embracing in our general conception of Gothic architecture; multitudes of street dwelling-houses and straggling country farm-houses, built with little care for beauty, or observance of Gothic laws in vaults or windows, and yet maintaining their character by the sharp and quaint gables of the roofs. And, for the reason just given, a house is far more Gothic which has square windows, and a boldly gabled roof, than the one which has pointed arches for the windows, and a domed or flat roof. For it often happened in the best Gothic times, as it must in all times, that it was more easy and convenient to make a window square than pointed; not but that, as above emphatically stated, the richness of church architecture was also found in domestic; and systematically "when the pointed arch was

used in the church it was used in the street," only in all times there were cases in which men could not build as they would, and were obliged to construct their doors or windows in the readiest way ; and this readiest way was then, in small work, as it will be to the end of time, to put a flat stone for a lintel and build the windows as in Fig. VIII. ; and the occurrence of such windows in a building or a street will not un-Gothicize them, so long as the bold gable roof be retained, and the spirit of the work be visibly Gothic in other respects. But if the roof be wilfully and conspicuously of any other form than the gable,—if it be domed, or Turkish, or Chinese,—the building has positive corruption mingled with its Gothic elements, in proportion to the conspicuousness of the roof ; and, if not absolutely un-Gothicized, can maintain its character only by such vigor of vital Gothic energy in other parts as shall cause the roof to be forgotten, thrown

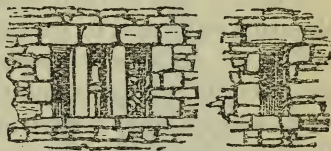

FIG. VIII.

off like an eschar from the living frame. Nevertheless, we must always admit that it *may* be forgotten, and that if the Gothic seal be indeed set firmly on the walls, we are not to cavil at the forms reserved for the tiles and leads. For, observe, as our definition at present stands, being understood of large roofs only, it will allow a conical glass-furnace to be a Gothic building, but will *not* allow so much, either of the Duomo of Florence, or the Baptistery of Pisa. We must either mend it, therefore, or understand it in some broader sense.

§ LXXXV. And now, if the reader will look back to the fifth paragraph of Chap. III. Vol. I., he will find that I carefully extended my definition of a roof so as to include more than is usually understood by the term. It was there said to be the covering of a space, *narrow or wide*. It does not in the least signify, with respect to the real nature of the covering, whether the space protected be two feet wide, or ten ; though in the one case we call the protection an arch, in the other a vault or roof. But the real point to be considered is, the manner in which this protection stands, and not whether it is narrow

or broad. We call the vaulting of a bridge "an arch," because it is narrow with respect to the river it crosses; but if it were built above us on the ground, we should call it a wagon vault, because then we should feel the breadth of it. The real question is the nature of the curve, not the extent of space over which it is carried: and this is more the case with respect to Gothic than to any other architecture; for, in the greater number of instances, the form of the roof is entirely dependent on the ribs; the domical shells being constructed in all kinds of inclinations, quite undeterminable by the eye, and all that is definite in their character being fixed by the curves of the ribs.

§ LXXXVI. Let us then consider our definition as including the narrowest arch, or tracery bar, as well as the broadest roof, and it will be nearly a perfect one. For the fact is, that all good Gothic is nothing more than the developement, in various ways, and on every conceivable scale, of the group formed by the *pointed arch for the bearing line* below, and the *gable for the protecting line* above; and from the huge, gray, shaly slope of the cathedral roof, with its elastic pointed vaults beneath,



FIG. IX.

to the slight crown-like points that enrich the smallest niche of its doorway, one law and one expression will be found in all. The modes of support and of decoration are infinitely various, but the real character of the building, in all good Gothic, depends upon the single lines of the gable over the pointed arch, Fig. IX., endlessly rearranged or repeated. The larger woodcut, Fig. X., represents three characteristic conditions of the treatment of the group: *a*, from a tomb at Verona (1328); *b*, one of the lateral porches at Abbeville; *c*, one of the uppermost points of the great western façade of Rouen Cathedral; both these last being, I believe, early work of the fifteenth century. The forms of the pure early English and French Gothic are too well known to need any notice; my reason will appear presently for choosing, by way of example, these somewhat rare conditions.

§ LXXXVII. But, first, let us try whether we cannot get the forms of the other great architectures of the world broadly

expressed by relations of the same lines into which we have compressed the Gothic. We may easily do this if the reader will first allow me to remind him of the true nature of the pointed arch, as it was expressed in § x. Chap. X. of the first volume. It was said there, that it ought to be called a “curved gable,” for, strictly speaking, an “arch” cannot be “pointed.” The so-called pointed arch ought always to be considered as a gable, with its sides curved in order to enable them to bear pressure from without. Thus considering it, there are but three ways in which an interval between piers can be bridged,—the three ways represented by A, B, and c, Fig. XI,* on page 214,—A, the lintel; B, the round arch; c, the gable. All the architects in the world will never discover any other ways of bridging a space than these three; they may vary the curve of the arch, or curve the sides of the gable, or break them; but in doing this they are merely modifying or subdividing, not adding to the generic forms.

§ LXXXVIII. Now there are three good architectures in the world, and there never can be more, correspondent to each of these three simple ways of covering in a space,

* Or by the shaded portions of Fig. XXIX. Vol. I.

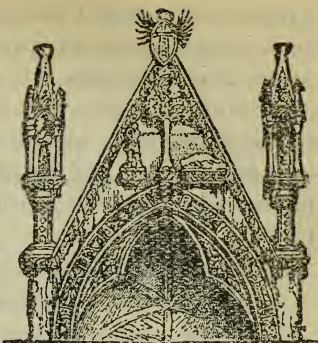

a



b

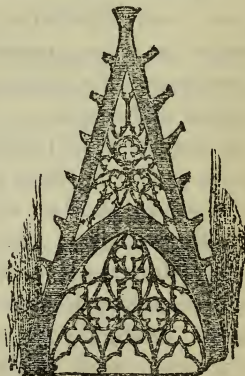

c

FIG. X.

which is the original function of all architectures. And those three architectures are *pure* exactly in proportion to the simplicity and directness with which they express the condition of roofing on which they are founded. They have many interesting varieties, according to their scale, manner of decoration, and character of the nations by whom they are practised, but all their varieties are finally referable to the three great heads:—

- A, Greek : Architecture of the Lintel.
- B, Romanesque : Architecture of the Round Arch.
- C, Gothic : Architecture of the Gable.



FIG. XI.

The three names, Greek, Romanesque, and Gothic, are indeed inaccurate when used in this vast sense, because they imply national limitations; but the three architectures may nevertheless not unfitly receive their names from those nations by whom they were carried to the highest perfections. We may thus briefly state their existing varieties.

§ LXXXIX. A. GREEK : Lintel Architecture. The worst of the three; and, considered with reference to stone construction, always in some measure barbarous. Its simplest type is Stonehenge; its most refined, the Parthenon; its noblest, the Temple of Karnak.

In the hands of the Egyptian, it is sublime; in those of the Greek, pure; in those of the Roman, rich; and in those of the Renaissance builder, effeminate.

B. ROMANESQUE : Round-arch Architecture. Never thoroughly developed until Christian times. It falls into two great branches, Eastern and Western, or Byzantine and Lombardic; changing respectively in process of time, with certain helps from each other, into Arabian Gothic and Teutonic Gothic. Its most perfect Lombardic type is the Duomo of

Fisa ; its most perfect Byzantine type (I believe), St. Mark's at Venice. Its highest glory is, that it has no corruption. It perishes in giving birth to another architecture as noble as itself.

c. GOTHIC: Architecture of the Gable. The daughter of the Romanesque ; and, like the Romanesque, divided into two great branches, Western and Eastern, or pure Gothic and Arabian Gothic ; of which the latter is called Gothic, only because it has many Gothic forms, pointed arches, vaults, &c., but its spirit remains Byzantine, more especially in the form of the roof-mask, of which, with respect to these three great families, we have next to determine the typical form.

§ xc. For, observe, the distinctions we have hitherto been stating, depend on the form of the stones first laid from pier to pier ; that is to say, of the simplest condition of roofs proper. Adding the relations of the roof-mask to these lines, we shall have the perfect type of form for each school.

In the Greek, the Western Romanesque, and Western Gothic, the roof-mask is the gable : in the Eastern Romanesque, and Eastern Gothic, it is the dome : but I have not studied the roofing of either of these last two groups, and shall not venture to generalize them

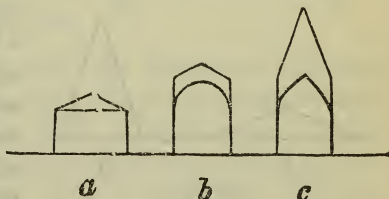

FIG. XII.

in a diagram. But the three groups, in the hands of the Western builders, may be thus simply represented : *a*, Fig. XII., Greek ; * *b*, Western Romanesque ; *c*, Western, or true, Gothic.

Now, observe, first, that the relation of the roof-mask to the roof proper, in the Greek type, forms that pediment which

* The reader is not to suppose that Greek architecture had always, or often, flat ceilings, because I call its lintel the roof proper. He must remember I always use these terms of the first simple arrangements of materials that bridge a space ; bringing in the real roof afterwards, if I can. In the case of Greek temples it would be vain to refer their structure to the real roof, for many were hypæthral, and without a roof at all. I am unfortunately more ignorant of Egyptian roofing than even

gives its most striking character to the temple, and is the principal recipient of its sculptural decoration. The relation of these lines, therefore, is just as important in the Greek as in the Gothic schools.

§ xci. Secondly, the reader must observe the difference of steepness in the Romanesque and Gothic gables. This is not an unimportant distinction, nor an undecided one. The Romanesque gable does not pass gradually into the more elevated form; there is a great gulf between the two; the whole effect of all Southern architecture being dependent upon the use of the flat gable, and of all Northern upon that of the acute. I need not here dwell upon the difference between the lines of an Italian village, or the flat tops of most Italian

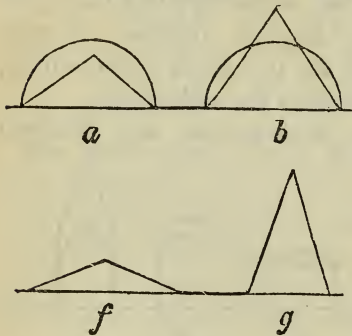

FIG. XIII.

towers, and the peaked gables and spires of the North, attaining their most fantastic development, I believe, in Belgium: but it may be well to state the law of separation, namely, that a Gothic gable *must* have all its angles acute, and a Romanesque one *must* have the upper one obtuse: or, to give the reader a simple practical rule, take any gable, *a* or *b*, Fig. XIII., and strike a semicircle on its base; if its top rises above the semicircle, as at *b*, it is a Gothic gable; if it falls beneath it, a Romanesque one; but the best forms in each group are those which are distinctly steep, or distinctly low. In the figure *f* is, perhaps, the average of Romanesque slope, and *g* of Gothic.

§ xcii. But although we do not find a transition from one school into the other in the slope of the gables, there is often

of Arabian, so that I cannot bring this school into the diagram; but the gable appears to have been magnificently used for a bearing roof. Vide Mr. Fergusson's section of the Pyramid of Geezeh, "Principles of Beauty in Art," Plate I., and his expressions of admiration of Egyptian roof masonry, page 201.

a confusion between the two schools in the association of the gable with the arch below it. It has just been stated that the pure Romanesque condition is the round arch under the low gable, *a*, Fig. XIV., and the pure Gothic condition is the pointed arch under the high gable, *b*. But in the passage from one style to the other, we sometimes find the two conditions reversed; the pointed arch under a low gable, as *d*, or the round arch under a high gable, as *c*. The form *d* occurs in the tombs of Verona, and *c* in the doors of Venice.

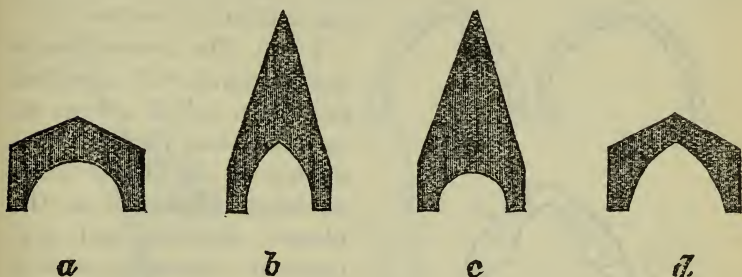

FIG. XIV.

§ XCIII. We have thus determined the relation of Gothic to the other architectures of the world, as far as regards the main lines of its construction; but there is still one word which needs to be added to our definition of its form, with respect to a part of its decoration, which rises out of that construction. We have seen that the first condition of its form is, that it shall have pointed arches. When Gothic is perfect, therefore, it will follow that the pointed arches must be built in the strongest possible manner.

Now, if the reader will look back to Chapter XI. of Vol. I., he will find the subject of the masonry of the pointed arch discussed at length, and the conclusion deduced, that of all possible forms of the pointed arch (a certain weight of material being given), that generically represented at *e*, Fig. XV., is the strongest. In fact, the reader can see in a moment that the weakness of the pointed arch is in its flanks, and that by merely thickening them gradually at this point all chance of fracture is removed. Or, perhaps, more simply still:—Sup-

pose a gable built of stone, as at *a*, and pressed upon from without by a weight in the direction of the arrow, clearly it

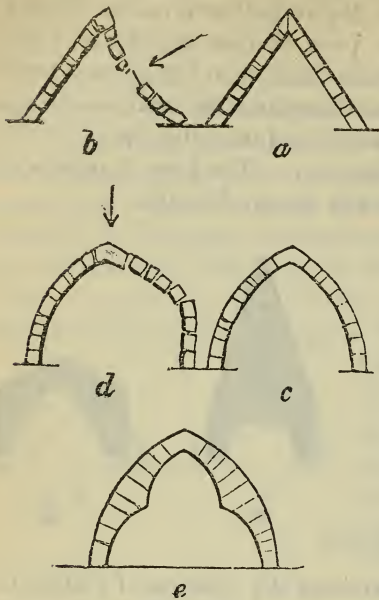

FIG. XV.

would be liable to fall in, as at *b*. To prevent this, we make a pointed arch of it, as at *c*; and now it cannot fall inwards, but if pressed upon from above may give way outwards, as at *d*. But at last we build as at *e*, and now it can neither fall out nor in.

§ xciv. The forms of arch thus obtained, with a pointed projection called a cusp on each side, must for ever be delightful to the human mind, as being expressive of the utmost strength and permanency obtainable with a given mass of material. But it was not by any such process of reasoning, nor with

any reference to laws of construction, that the cusp was originally invented. It is merely the special application to the arch of the great ornamental system of FOLIATION; or the adaptation of the forms of leafage which has been above insisted upon as the principal characteristic of Gothic Naturalism. This love of foliage was exactly proportioned, in its intensity, to the increase of strength in the Gothic spirit: in the Southern Gothic it is *soft* leafage that is most loved; in the Northern *thorny* leafage. And if we take up any Northern illuminated manuscript of the great Gothic time, we shall find every one of its leaf ornaments surrounded by a thorny structure laid round it in gold or in color; sometimes apparently copied faithfully from the prickly development of the root of the leaf in the thistle, running along the stems and branches exactly as the thistle leaf does along its own stem, and with sharp spines proceeding from the points, as in Fig.

XVI. At other times, and for the most part in work in the thirteenth century, the golden ground takes the form of pure and severe cusps, sometimes enclosing the leaves, sometimes filling up the forks of the branches (as in the example fig. 1, Plate I. Vol. III.), passing imperceptibly from the distinctly vegetable condition (in which it is just as certainly representative of the thorn, as other parts of the design are of the bud, leaf, and fruit) into the crests on the necks, or the membranous sails of the wings, of serpents, dragons, and other grotesques, as in Fig. XVII., and into rich and vague fantasies of



FIG. XVI.



FIG. XVII.

curvature ; among which, however, the pure cusped system of the pointed arch is continually discernible, not accidentally, but designedly indicated, and connecting itself with the literally architectural portions of the design.

§ xc. The system, then, of what is called Foliation, whether simple, as in the cusped arch, or complicated, as in tracery, rose out of this love of leafage ; not that the form of the arch is intended to *imitate* a leaf, but *to be invested with the same characters of beauty which the designer had discovered in the leaf*. Observe, there is a wide difference between these two intentions. The idea that large Gothic structure, in arches and roofs, was intended to imitate vegetation is, as above noticed, untenable for an instant in the front of facts. But the Gothic

builder perceived that, in the leaves which he copied for his minor decorations, there was a peculiar beauty, arising from certain characters of curvature in outline, and certain methods of subdivision and of radiation in structure. On a small scale, in his sculptures and his missal-painting, he copied the leaf or thorn itself; on a large scale he adopted from it its abstract sources of beauty, and gave the same kinds of curvatures and the same species of subdivision to the outline of his arches, so far as was consistent with their strength, never, in any single instance, suggesting the resemblance to leafage by *irregularity* of outline, but keeping the structure perfectly simple, and, as we have seen, so consistent with the best principles of masonry, that in the finest Gothic designs of arches, which are always *single* cusped (the cinquefoiled arch being licentious, though in early work often very lovely), it is literally impossible, without consulting the context of the building, to say whether the cusps have been added for the sake of beauty or of strength; nor, though in mediæval architecture they were, I believe, assuredly first employed in mere love of their picturesque form, am I absolutely certain that their earliest invention was not a structural effort. For the earliest cusps with which I am acquainted are those used in the vaults of the great galleries of the Serapeum, discovered in 1850 by M. Maniette at Memphis, and described by Colonel Hamilton in a paper read in February last before the Royal Society of Literature.* The roofs of its galleries were admirably shown in Colonel Hamilton's drawings made to scale upon the spot, and their profile is a cusped round arch, perfectly pure and simple; but whether thrown into this form for the sake of strength or of grace, I am unable to say.

§ xcvi. It is evident, however, that the structural advantage of the cusp is available only in the case of arches on a comparatively small scale. If the arch becomes very large, the projections under the flanks must become too ponderous to be secure; the suspended weight of stone would be liable to break off, and such arches are therefore never constructed with heavy cusps, but rendered secure by general mass of

* See 'Athenæum,' March 5th, 1853.

masonry ; and what additional *appearance* of support may be thought necessary (sometimes a considerable degree of *actual* support) is given by means of tracery.

§ xcviI. Of what I stated in the second chapter of the "Seven Lamps" respecting the nature of tracery, I need repeat here only this much, that it began in the use of penetrations through the stonework of windows or walls, cut into forms which looked like stars when seen from within, and like leaves when seen from without : the name foil or feuille being universally applied to the separate lobes of their extremities, and the pleasure received from them being the same as that which we feel in the triple, quadruple, or other radiated leaves of vegetation, joined with the perception of a severely geometrical order and symmetry. A few of the most common forms are represented, unconfused by exterior mouldings, in Fig. XVIII, and the best traceries are nothing more than close clusters of such forms, with mouldings following their outlines.

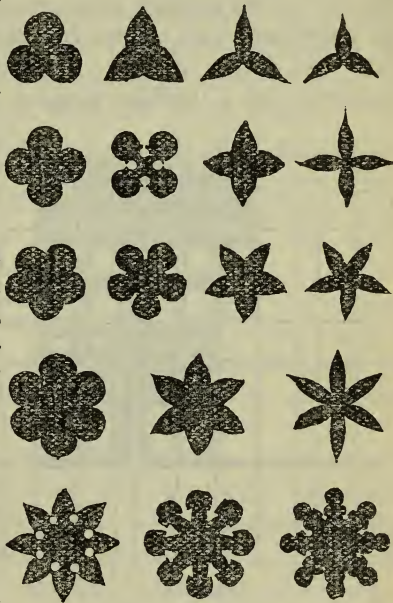

FIG. XVIII.

§ xcviII. The term "foliated," therefore, is equally descriptive of the most perfect conditions both of the simple arch and of the traceries by which, in later Gothic, it is filled ; and this foliation is an essential character of the style. No Gothic is either good or characteristic which is not foliated either in its arches or apertures. Sometimes the bearing arches are foliated, and the ornamentation above composed of figure sculpture ; sometimes the bearing arches are plain, and the ornamentation above them is composed of foliated apertures. But the ele-

ment of foliation *must* enter somewhere, or the style is imperfect. And our final definition of Gothic will, therefore, stand thus :—

“*Foliated Architecture*, which uses the pointed arch for the roof proper, and the gable for the roof-mask.”

§ XCIX. And now there is but one point more to be examined, and we have done.

Foliation, while it is the most distinctive and peculiar, is also the easiest method of decoration which Gothic architecture possesses ; and, although in the disposition of the proportions and forms of foils, the most noble imagination may be shown, yet a builder without imagination at all, or any

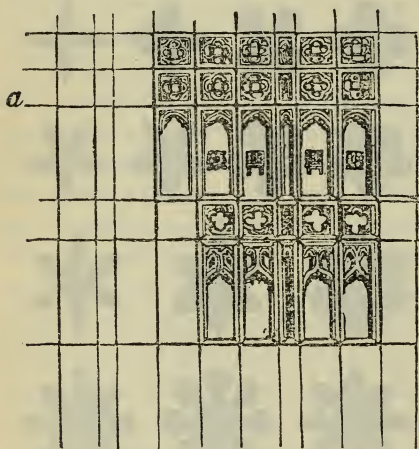

FIG. XIX.

other faculty of design, can produce some effect upon the mass of his work by merely covering it with foolish foliation. Throw any number of crossing lines together at random, as in Fig. XIX., and fill their squares and oblong openings with quatrefoils and cinquefoils, and you will immediately have what will stand, with most people, for very satisfactory Gothic. The slightest possible acquaintance

with existing forms will enable any architect to vary his patterns of foliation with as much ease as he would those of a kaleidoscope, and to produce a building which the present European public will think magnificent, though there may not be, from foundation to coping, one ray of invention, or any other intellectual merit, in the whole mass of it. But floral decoration, and the disposition of mouldings, require some skill and thought ; and, if they are to be agreeable at all, must be verily invented, or accurately copied. They cannot be drawn altogether at random, without becoming so commonplace as to involve detec-

tion . and although, as I have just said, the noblest imagination may be shown in the dispositions of traceries, there is far more room for its play and power when those traceries are associated with floral or animal ornament ; and it is probable, *à priori*, that, wherever true invention exists, such ornament will be employed in profusion.

§ c. Now, all Gothic may be divided into two vast schools, one early, the other late ;* of which the former, noble, inventive, and progressive, uses the element of foliation moderately, that of floral and figure sculpture decoration profusely ; the latter, ignoble, uninventive, and declining, uses foliation immoderately, floral and figure sculpture subordinately. The two schools touch each other at that instant of momentous change, dwelt upon in the " Seven Lamps," chap. ii., a period later or earlier in different districts, but which may be broadly stated as the middle of the fourteenth century ; both styles being, of course, in their highest excellence at the moment when they meet, the one ascending to the point of junction, the one declining from it, but, at first, not in any marked degree, and only showing the characters which justify its being above called, generically, ignoble, as its declension reaches steeper slope.

§ cr. Of these two great schools, the first uses foliation only in large and simple masses, and covers the minor members, cusps, &c., of that foliation, with various sculpture. The latter decorates foliation itself with minor foliation, and breaks its traceries into endless and lace-like subdivision of tracery.

A few instances will explain the difference clearly. Fig. 2, Plate XII., represents half of an eight-foiled aperture from Salisbury ; where the element of foliation is employed in the larger disposition of the starry form ; but in the decoration of the cusp it has entirely disappeared, and the ornament is floral.

But in fig. 1, which is part of a fringe round one of the later windows in Rouen Cathedral, the foliation is first carried

* Late, and chiefly confined to Northern countries, so that the two schools may be opposed either as Early and Late Gothic, or (in the fourteenth century) as Southern and Northern Gothic.

boldly round the arch, and then each cusp of it divided into other forms of foliation. The two larger canopies of niches below, figs. 5 and 6, are respectively those seen at the flanks of the two uppermost examples of gabled Gothic in Fig. X., p. 213. Those examples were there chosen in order also to illustrate the distinction in the character of ornamentation which we are at present examining; and if the reader will look back to them, and compare their methods of treatment, he will at once be enabled to fix that distinction clearly in his mind. He will observe that in the uppermost the element of foliation is scrupulously confined to the bearing arches of the gable, and of the lateral niches, so that, on any given side of the monument, only three foliated arches are discernible. All the rest of the ornamentation is "bossy sculpture," set on the broad marble surface. On the point of the gable are set the shield and dog-crest of the Scalas, with its bronze wings, as of a dragon, thrown out from it on either side; below, an admirably sculptured oak-tree fills the centre of the field; beneath it is the death of Abel, Abel lying dead upon his face on one side, Cain opposite, looking up to heaven in terror: the border of the arch is formed of various leafage, alternating with the scala shield; and the cusps are each filled by one flower, and two broad flowing leaves. The whole is exquisitely relieved by color; the ground being of pale red Verona marble, and the statues and foliage of white Carrara marble, inlaid.

§ cii. The figure below it, *b*, represents the southern lateral door of the principal church in Abbeville: the smallness of the scale compelled me to make it somewhat heavier in the lines of its traceries than it is in reality, but the door itself is one of the most exquisite pieces of flamboyant Gothic in the world; and it is interesting to see the shield introduced here, at the point of the gable, in exactly the same manner as in the upper example, and with precisely the same purpose,—to stay the eye in its ascent, and to keep it from being offended by the sharp point of the gable, the reversed angle of the shield being so energetic as completely to balance the upward tendency of the great convergent lines. It will be seen, however;

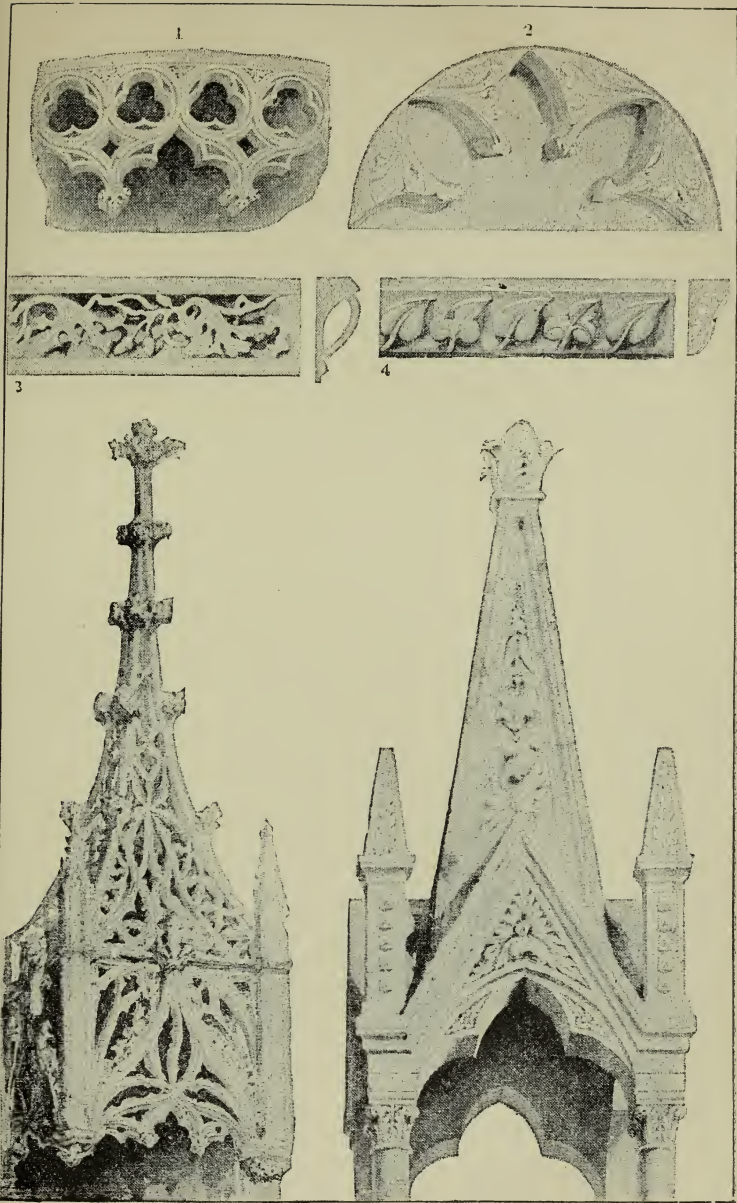

PLATE XII.—LINEAR AND SURFACE GOTHIC.

as this example is studied, that its other decorations are altogether different from those of the Veronese tomb ; that, here, the whole effect is dependent on mere multiplications of similar lines of tracery, sculpture being hardly introduced except in the seated statue under the central niche, and, formerly, in groups filling the shadowy hollows under the small niches in the archivolt, but broken away in the Revolution. And if now we turn to Plate XII., just passed, and examine the heads of the two lateral niches there given from each of these monuments on a larger scale, the contrast will be yet more apparent. The one from Abbeville (fig. 5), though it contains much floral work of the crisp Northern kind in its finial and crockets, yet depends for all its effect on the various patterns of foliation with which its spaces are filled ; and it is so cut through and through that it is hardly stronger than a piece of lace : whereas the pinnacle from Verona depends for its effect on one broad mass of shadow, boldly shaped into the trefoil in its bearing arch ; and there is no other trefoil on that side of the niche. All the rest of its decoration is floral, or by almonds and bosses ; and its surface of stone is unpierced, and kept in broad light, and the mass of it thick and strong enough to stand for as many more centuries as it has already stood, scatheless, in the open street of Verona. The figures 3 and 4, above each niche, show how the same principles are carried out into the smallest details of the two edifices, 3 being the moulding which borders the gable at Abbeville, and 4, that in the same position at Verona ; and as thus in all cases the distinction in their treatment remains the same, the one attracting the eye to broad sculptured *surfaces*, the other to involutions of intricate *lines*, I shall hereafter characterize the two schools, whenever I have occasion to refer to them, the one as Surface-Gothic, the other as Linear-Gothic.

§ ciii. Now observe : it is not, at present, the question, whether the form of the Veronese niche, and the design of its flower-work, be as good as they might have been ; but simply, which of the two architectural principles is the greater and better. And this we cannot hesitate for an instant in deciding. The Veronese Gothic is strong in its masonry, simple

in its masses, but perpetual in its variety. The late French Gothic is weak in masonry, broken in mass, and repeats the same idea continually. It is very beautiful, but the Italian Gothic is the nobler style.

§ civ. Yet, in saying that the French Gothic repeats one idea, I mean merely that it depends too much upon the foliation of its traceries. The disposition of the traceries themselves is endlessly varied and inventive ; and indeed, the mind of the French workman was, perhaps, even richer in fancy than that of the Italian, only he had been taught a less noble style. This is especially to be remembered with respect to the subordination of figure sculpture above noticed as characteristic of the later Gothic.

It is not that such sculpture is wanting ; on the contrary, it is often worked into richer groups, and carried out with a perfection of execution, far greater than those which adorn the earlier buildings : but, in the early work, it is vigorous, prominent, and essential to the beauty of the whole ; in the late work it is enfeebled, and shrouded in the veil of tracery, from which it may often be removed with little harm to the general effect.*

§ cv. Now the reader may rest assured that no principle of art is more absolute than this,—that a composition from which anything can be removed without doing mischief is always so far forth inferior. On this ground, therefore, if on no other, there can be no question, for a moment, which of the two schools is the greater ; although there are many most noble works in the French traceried Gothic, having a sublimity of their own dependent on their extreme richness and grace of line, and for which we may be most grateful to their builders. And, indeed, the superiority of the Surface-Gothic cannot be completely felt, until we compare it with the more

* In many of the best French Gothic churches, the groups of figures have been all broken away at the Revolution, without much harm to the picturesqueness, though with grievous loss to the historical value of the architecture : whereas, if from the niche at Verona we were to remove its floral ornaments, and the statue beneath it, nothing would remain but a rude square trefoiled shell, utterly valueless, or even ugly.

degraded Linear schools, as, for instance, with our own English Perpendicular. The ornaments of the Veronese niche, which we have used for our example, are by no means among the best of their school, yet they will serve our purpose for such a comparison. That of its pinnacle is composed of a single upright flowering plant, of which the stem shoots up through the centres of the leaves, and bears a pendent blossom, somewhat like that of the imperial lily. The leaves are thrown back from the stem with singular grace and freedom, and foreshortened, as if by a skilful painter, in the shallow marble relief. Their arrangement is roughly shown in the little wood-cut at the side (Fig. XX.); and if the reader will simply try the experiment for himself,—first, of covering a piece of paper with crossed lines, as if for accounts, and filling all the interstices with any foliation that comes into his head, as in Figure XIX. above; and then, of trying to fill the point of a gable with a piece of leafage like that in Figure XX., putting the figure itself aside,—he will presently find that more thought and invention are required to design this single minute pinnacle, than to cover acres of ground with English perpendicular.



FIG. XX.

§ CVI. We have now, I believe, obtained a sufficiently accurate knowledge both of the spirit and form of Gothic architecture; but it may, perhaps, be useful to the general reader, if, in conclusion, I set down a few plain and practical rules for determining, in every instance, whether a given building be good Gothic or not, and, if not Gothic, whether its architecture is of a kind which will probably reward the pains of careful examination.

§ CVII. First. Look if the roof rises in a steep gable, high above the walls. If it does not do this, there is something

wrong ; the building is not quite pure Gothic, or has been altered.

§ CVIII. Secondly. Look if the principal windows and doors have pointed arches with gables over them. If not pointed arches, the building is not Gothic ; if they have not any gables over them, it is either not pure, or not first-rate.

If, however, it has the steep roof, the pointed arch, and gable all united, it is nearly certain to be a Gothic building of a very fine time.

§ CIX. Thirdly. Look if the arches are cusped, or apertures foliated. If the building has met the first two conditions, it is sure to be foliated somewhere ; but, if not everywhere, the parts which are unfoliated are imperfect, unless they are large bearing arches, or small and sharp arches in groups, forming a kind of foliation by their own multiplicity, and relieved by sculpture and rich mouldings. The upper windows, for instance, in the east end of Westminster Abbey are imperfect for want of foliation. If there be no foliation anywhere, the building is assuredly imperfect Gothic.

§ CX. Fourthly. If the building meets all the first three conditions, look if its arches in general, whether of windows and doors, or of minor ornamentation, are carried on *true shafts with bases and capitals*. If they are, then the building is assuredly of the finest Gothic style. It may still, perhaps, be an imitation, a feeble copy, or a bad example of a noble style ; but the manner of it, having met all these four conditions, is assuredly first-rate.

If its apertures have not shafts and capitals, look if they are plain openings in the walls, studiously simple, and unmoulded at the sides ; as, for instance, the arch in Plate XIX., Vol. I. If so, the building may still be of the finest Gothic, adapted to some domestic or military service. But if the sides of the window be moulded, and yet there are no capitals at the spring of the arch, it is assuredly of an inferior school.

This is all that is necessary to determine whether the building be of a fine Gothic style. The next tests to be applied are in order to discover whether it be good architecture or not : for it may be very impure Gothic, and yet very noble

architecture ; or it may be very pure Gothic, and yet, if a copy, or originally raised by an ungifted builder, very bad architecture.

If it belong to any of the great schools of color, its criticism becomes as complicated, and needs as much care, as that of a piece of music, and no general rules for it can be given ; but if not—

§ cxl. First. See if it looks as if it had been built by strong men ; if it has the sort of roughness, and largeness, and nonchalance, mixed in places with the exquisite tenderness which seems always to be the sign-manual of the broad vision, and massy power of men who can see *past* the work they are doing, and betray here and there something like disdain for it. If the building has this character, it is much already in its favor ; it will go hard but it proves a noble one. If it has not this, but is altogether accurate, minute, and scrupulous in its workmanship, it must belong to either the very best or the very worst of schools : the very best, in which exquisite design is wrought out with untiring and conscientious care, as in the Giottesque Gothic ; or the very worst, in which mechanism has taken the place of design. It is more likely, in general, that it should belong to the worst than the best : so that, on the whole, very accurate workmanship is to be esteemed a bad sign ; and if there is nothing remarkable about the building but its precision, it may be passed at once with contempt.

§ cxii. Secondly. Observe if it be irregular, its different parts fitting themselves to different purposes, no one caring what becomes of them, so that they do their work. If one part always answers accurately to another part, it is sure to be a bad building ; and the greater and more conspicuous the irregularities, the greater the chances are that it is a good one. For instance, in the Ducal Palace, of which a rough woodcut is given in Chap. VIII., the general idea is sternly symmetrical ; but two windows are lower than the rest of the six ; and if the reader will count the arches of the small arcade as far as to the great balcony, he will find it is not in the centre, but set to the right-hand side by the whole width of one of those

arches. We may be pretty sure that the building is a good one ; none but a master of his craft would have ventured to do this.

§ CXIII. Thirdly. Observe if all the traceries, capitals, and other ornaments are of perpetually varied design. If not, the work is assuredly bad.

§ CXIV. Lastly. *Read* the sculpture. Preparatory to reading it, you will have to discover whether it is legible (and, if legible, it is nearly certain to be worth reading). On a good building, the sculpture is *always* so set, and on such a scale, that at the ordinary distance from which the edifice is seen, the sculpture shall be thoroughly intelligible and interesting. In order to accomplish this, the uppermost statues will be ten or twelve feet high, and the upper ornamentation will be colossal, increasing in fineness as it descends, till on the foundation it will often be wrought as if for a precious cabinet in a king's chamber ; but the spectator will not notice that the upper sculptures are colossal. He will merely feel that he can see them plainly, and make them all out at his ease.

And, having ascertained this, let him set himself to read them. Thenceforward the criticism of the building is to be conducted precisely on the same principles as that of a book ; and it must depend on the knowledge, feeling, and not a little on the industry and perseverance of the reader, whether, even in the case of the best works, he either perceive them to be great, or feel them to be entertaining.

CHAPTER VII.

GOTHIC PALACES.

§ I. THE buildings out of the remnants of which we have endeavored to recover some conception of the appearance of Venice during the Byzantine period, contribute hardly anything at this day to the effect of the streets of this city. They are too few and too much defaced to attract the eye or influence the feelings. The charm which Venice still posses-

ses, and which for the last fifty years has rendered it the favorite haunt of all the painters of picturesque subject, is owing to the effect of the palaces belonging to the period we have now to examine, mingled with those of the Renaissance.

This effect is produced in two different ways. The Renaissance palaces are not more picturesque in themselves than the club-houses of Pall Mall; but they become delightful by the contrast of their severity and refinement with the rich and rude confusion of the sea life beneath them, and of their white and solid masonry with the green waves. Remove from beneath them the orange sails of the fishing boats, the black gliding of the gondolas, the cumbered decks and rough crews of the barges of traffic, and the fretfulness of the green water along their foundations, and the Renaissance palaces possess no more interest than those of London or Paris. But the Gothic palaces are picturesque in themselves, and wield over us an independent power. Sea and sky, and every other accessory might be taken away from them, and still they would be beautiful and strange. They are not less striking in the loneliest streets of Padua and Vicenza (where many were built during the period of the Venetian authority in those cities) than in the most crowded thoroughfares of Venice itself; and if they could be transported into the midst of London, they would still not altogether lose their power over the feelings.

§ II. The best proof of this is in the perpetual attractiveness of all pictures, however poor in skill, which have taken for their subject the principal of these Gothic buildings, the Ducal Palace. In spite of all architectural theories and teachings, the paintings of this building are always felt to be delightful; we cannot be wearied by them, though often sorely tried; but we are not put to the same trial in the case of the palaces of the Renaissance. They are never drawn singly, or as the principal subject, nor can they be. The building which faces the Ducal Palace on the opposite side of the Piazzetta is celebrated among architects, but it is not familiar to our eyes; it is painted only incidentally, for the completion, not the

subject, of a Venetian scene ; and even the Renaissance arcades of St. Mark's Place, though frequently painted, are always treated as a mere avenue to its Byzantine church and colossal tower. And the Ducal Palace itself owes the peculiar charm which we have hitherto felt, not so much to its greater size as compared with other Gothic buildings, or nobler design (for it never yet has been rightly drawn), as to its comparative isolation. The other Gothic structures are as much injured by the continual juxtaposition of the Renaissance palaces, as the latter are aided by it ; they exhaust their own life by breathing it into the Renaissance coldness : but the Ducal Palace stands comparatively alone, and fully expresses the Gothic power.

§ III. And it is just that it should be so seen, for it is the original of nearly all the rest. It is not the elaborate and more studied developement of a national style, but the great and sudden invention of one man, instantly forming a national style, and becoming the model for the imitation of every architect in Venice for upwards of a century. It was the determination of this one fact which occupied me the greater part of the time I spent in Venice. It had always appeared to me most strange that there should be in no part of the city any incipient or imperfect types of the form of the Ducal Palace ; it was difficult to believe that so mighty a building had been the conception of one man, not only in disposition and detail, but in style ; and yet impossible, had it been otherwise, but that some early examples of approximate Gothic form must exist. There is not one. The palaces built between the final cessation of the Byzantine style, about 1300, and the date of the Ducal Palace (1320-1350), are all completely distinct in character, so distinct that I at first intended the account of them to form a separate section of this volume ; and there is literally *no* transitional form between them and the perfection of the Ducal Palace. Every Gothic building in Venice which resembles the latter is a copy of it. I do not mean that there was no Gothic in Venice before the Ducal Palace, but that the mode of its application to domestic architecture had not been determined.

The real root of the Ducal Palace is the apse of the church of the Frari. The traceries of that apse, though earlier and ruder in workmanship, are nearly the same in mouldings, and precisely the same in treatment (especially in the placing of the lions' heads), as those of the great Ducal Arcade; and the originality of thought in the architect of the Ducal Palace consists in his having adapted those traceries, in a more highly developed and finished form, to civil uses. In the apse of the church they form narrow and tall window lights, somewhat more massive than those of Northern Gothic, but similar in application: the thing to be done was to adapt these traceries to the forms of domestic building necessitated by national usage. The early palaces consisted, as we have seen, of arcades sustaining walls faced with marble, rather broad and long than elevated. This form was kept for the Ducal Palace; but instead of round arches from shaft to shaft, the Frari traceries were substituted, with two essential modifications. Besides being

enormously increased in scale and thickness, that they might better bear the superincumbent weight, the quatrefoil, which in the Frari windows is above the arch, as at *a*, Fig. XXI., was, in the Ducal Palace, put between the arches, as at *b*;

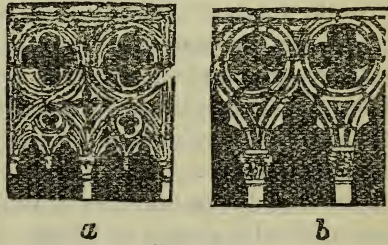

FIG. XXI.

the main reason for this alteration being that the bearing power of the arches, which was now to be trusted with the weight of a wall forty feet high,* was thus thrown *between* the quatrefoils, instead of under them, and thereby applied at far better advantage. And, in the second place, the joints of the masonry were changed. In the Frari (as often also in St. John and St. Paul's) the tracery is formed of two simple cross bars or slabs of stone, pierced into the requisite forms, and separated

* 38 ft. 2 in., without its cornice, which is 10 inches deep, and sustains pinnacles of stone 7 feet high. I was enabled to get the measures by a scaffolding erected in 1851 to repair the front.

by a horizontal joint, just on a level with the lowest cusp of the quatrefoils, as seen in Fig. XXI, *a*. But at the Ducal Palace the horizontal joint is in the centre of the quatrefoils, and two others are introduced beneath it at right angles to the run of the mouldings, as seen in Fig. XXI, *b*.* The Ducal Palace builder was sternly resolute in carrying out this rule of masonry. In the traceries of the large upper windows, where the cusps are cut through as in the quatrefoil Fig. XXII., the lower cusp is left partly solid, as at *a*, merely that the joint *a* *b* may have its right place and direction.

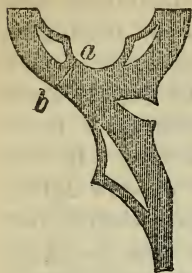

FIG. XXII.

§ iv. The ascertaining the formation of the Ducal Palace traceries from those of the Frari, and its priority to all other buildings which resemble it in Venice, rewarded me for a great deal of uninteresting labor in the examination of mouldings and other minor features of the Gothic palaces, in which alone the internal evidence of their date was to be discovered, there being no historical records whatever respecting them. But the accumulation of details on which the complete proof of the fact depends, could not either be brought within the compass of this volume, or be made in anywise interesting to the general reader. I shall therefore, without involving myself in any discussion, give a brief account of the development of Gothic design in Venice, as I believe it to have taken place. I shall possibly be able at some future period so to compress the evidence on which my conviction rests, as to render it intelligible to the public, while, in the meantime, some of the more essential points of it are thrown together in the Appendix, and in the history of the Ducal Palace given in the next chapter.

§ v. According, then, to the statement just made, the Gothic architecture of Venice is divided into two great periods: one, in which, while various irregular Gothic tendencies are

* I believe the necessary upper joint is vertical, through the uppermost lobe of the quatrefoil, as in the figure; but I have lost my memorandum of this joint.

exhibited, no consistent type of domestic building was developed; the other, in which a formed and consistent school of domestic architecture resulted from the direct imitation of the great design of the Ducal Palace. We must deal with these two periods separately; the first of them being that which has been often above alluded to, under the name of the transitional period.

We shall consider in succession the general form, the windows, doors, balconies, and parapets, of the Gothic palaces belonging to each of these periods.

§ VI. First. General Form.

We have seen that the wrecks of the Byzantine palaces consisted merely of upper and lower arcades surrounding cortiles; the disposition of the interiors being now entirely changed, and their original condition untraceable. The entrances to these early buildings are, for the most part, merely large circular arches, the central features of their continuous arcades: they do not present us with definitely separated windows and doors.

But a great change takes place in the Gothic period. These long arcades break, as it were, into pieces, and coagulate into central and lateral windows, and small arched doors, pierced in great surfaces of brick wall. The sea story of a Byzantine palace consists of seven, nine, or more arches in a continuous line; but the sea story of a Gothic palace consists of a door and one or two windows on each side, as in a modern house. The first story of a Byzantine palace consists of, perhaps, eighteen or twenty arches, reaching from one side of the house to the other; the first story of a Gothic palace consists of a window of four or five lights in the centre, and one or two single windows on each side. The germ, however, of the Gothic arrangement is already found in the Byzantine, where, as we have seen, the arcades, though continuous, are always composed of a central mass and two wings of smaller arches. The central group becomes the door or the middle light of the Gothic palace, and the wings break into its lateral windows.

§ VII. But the most essential difference in the entire ar-

rangement, is the loss of the unity of conception which regulated Byzantine composition. How subtle the sense of gradation which disposed the magnitudes of the early palaces we have seen already, but I have not hitherto noticed that the Byzantine work was centralized in its ornamentation as much as in its proportions. Not only were the lateral capitals and archivolts kept comparatively plain, while the central ones were sculptured, but the midmost piece of sculpture, whatever it might be,—capital, inlaid circle, or architrave,—was always made superior to the rest. In the Fondaco de' Turchi, for instance, the midmost capital of the upper arcade is the key to the whole group, larger and more studied than all the rest; and the lateral ones are so disposed as to answer each other on the opposite sides, thus, A being put for the central one,

F E B C **A** C B E F,

a sudden break of the system being admitted in one unique capital at the extremity of the series.

§ VIII. Now, long after the Byzantine arcades had been contracted into windows, this system of centralization was more or less maintained; and in all the early groups of windows of five lights the midmost capital is different from the two on each side of it, which always correspond. So strictly is this the case, that whenever the capitals of any group of windows are not centralized in this manner, but are either entirely like each other, or all different, so as to show no correspondence, it is a certain proof, even if no other should exist, of the comparative lateness of the building.

In every group of windows in Venice which I was able to examine, and which were centralized in this manner, I found evidence in their mouldings of their being *anterior* to the Ducal Palace. That palace did away with the subtle proportion and centralization of the Byzantine. Its arches are of equal width, and its capitals are all different and ungrouped; some, indeed, are larger than the rest, but this is not for the sake of proportion, only for particular service when more weight is to be borne. But, among other evidences of the

early date of the sea façade of that building, is one subtle and delicate concession to the system of centralization which is finally closed. The capitals of the upper arcade are, as I said, all different, and show no arranged correspondence with each other; but *the central one is of pure Parian marble*, while all the others are of Istrian stone.

The bold decoration of the central window and balcony above, in the Ducal Palace, is only a peculiar expression of the principality of the central window, which was characteristic of the Gothic period not less than of the Byzantine. In the private palaces the central windows become of importance by their number of lights; in the Ducal Palace such an arrangement was, for various reasons, inconvenient, and the central window, which, so far from being more important than the others, is every way inferior in design to the two at the eastern extremity of the façade, was nevertheless made the leading feature by its noble canopy and balcony.

§ ix. Such being the principal differences in the general conception of the Byzantine and Gothic palaces, the particulars in the treatment of the latter are easily stated. The marble facings are gradually removed from the walls; and the bare brick either stands forth confessed boldly, contrasted with the marble shafts and archivolt of the windows, or it is covered with stucco painted in fresco, of which more hereafter. The Ducal Palace, as in all other respects, is an exact expression of the middle point in the change. It still retains marble facing; but instead of being disposed in slabs as in the Byzantine times, it is applied in solid bricks or blocks of marble, $11\frac{1}{2}$ inches long, by 6 inches high.

The stories of the Gothic palaces are divided by string courses, considerably bolder in projection than those of the Byzantines, and more highly decorated; and while the angles of the Byzantine palaces are quite sharp and pure, those of the Gothic palaces are wrought into a chamfer, filled by small twisted shafts which have capitals under the cornice of each story.

§ x. These capitals are little observed in the general effect, but the shafts are of essential importance in giving an aspect

of firmness to the angle ; a point of peculiar necessity in Venice, where, owing to the various convolutions of the canals, the angles of the palaces are not only frequent, but often necessarily *acute*, every inch of ground being valuable. In other cities, the appearance as well as the assurance of stability can always be secured by the use of massy stones, as in the fortress palaces of Florence ; but it must have been always desirable at Venice to build as lightly as possible, in consequence of the comparative insecurity of the foundations. The early palaces were, as we have seen, perfect models of grace and lightness, and the Gothic, which followed, though much more massive in the style of its details, never admitted more weight into its structure than was absolutely necessary for its strength. Hence, every Gothic palace has the appearance of enclosing as many rooms, and attaining as much strength, as is possible, with a minimum quantity of brick and stone. The traceries of the windows, which in Northern Gothic only support the *glass*, at Venice support the *building* ; and thus the greater ponderousness of the *traceries* is only an indication of the greater lightness of the *structure*. Hence, when the Renaissance architects give their opinions as to the stability of the Ducal Palace when injured by fire, one of them, Christofore Sorte, says, that he thinks it by no means laudable that the "Serenissimo Dominio" of the Venetian senate "should live in a palace built in the air."* And again, Andrea della Valle says, that † "the wall of the saloon is thicker by fifteen inches than the shafts below it, projecting nine inches within, and six without, *standing as if in the air*, above the piazza ; ‡ and yet this wall is so nobly and strongly knit together, that Rusconi, though himself altogether devoted to the Renaissance school, declares that the fire which

* "Dice, che non lauda per alcun modo di metter questo Serenissimo Dominio in tanto pericolo d' habitar un palazzo fabricato in aria."—*Pareri di XV. Architetti, con illustrazioni dell' Abbate Giuseppe Cadorin* (Venice, 1838), p. 104.

† "Il muro della sala è più grosso delle colonne sott' esso piedi uno e onze tre, et posto in modo che onze sei sta come in aere sopra la piazza, et onze nove dentro."—*Pareri di XV. Architetti*, p. 47.

‡ Compare "Seven Lamps," chap. iii. § 7.

had destroyed the whole interior of the palace had done this wall no more harm than the bite of a fly to an elephant. "Troveremo che el danno che ha patito queste muraglie sarà conforme alla beccatura d' una mosca fatta ad un elefante."*

§ XI. And so in all the other palaces built at the time, consummate strength was joined with a lightness of form and sparingness of material which rendered it eminently desirable that the eye should be convinced, by every possible expedient, of the stability of the building; and these twisted pillars at the angles are not among the least important means adopted for this purpose, for they seem to bind the walls together as a cable binds a chest. In the Ducal Palace, where they are carried up the angle of an unbroken wall forty feet high, they are divided into portions, gradually diminishing in length towards the top, by circular bands or rings, set with the nail-head or dog-tooth ornament, vigorously projecting, and giving the column nearly the aspect of the stalk of a reed; its diminishing proportions being exactly arranged as they are by Nature in all jointed plants. At the top of the palace, like the wheat-stalk branching into the ear of corn, it expands into a small niche with a pointed canopy, which joins with the fantastic parapet in at once relieving, and yet making more notable by its contrast, the weight of massy wall below. The arrangement is seen in the woodcut, Chap. VIII.; the angle shafts being slightly exaggerated in thickness, together with their joints, as otherwise they would hardly have been intelligible on so small a scale.

The Ducal Palace is peculiar in these niches at the angles, which throughout the rest of the city appear on churches only; but some may perhaps have been removed by restorations, together with the parapets with which they were associated.

§ XII. Of these roof parapets of Venice, it has been already noticed that the examples which remain differ from those of all other cities of Italy in their purely ornamental character. (Chap. I. § XII.) They are not battlements, properly so-called; still less machicolated cornices, such as crown the fortress

* Pareri, p. 21, before quoted.

palaces of the great mainland nobles ; but merely adaptations of the light and crown-like ornaments which crest the walls of the Arabian mosque. Nor are even these generally used on the main walls of the palaces themselves. They occur on the Ducal Palace, on the Casa d' Oro, and, some years back, were still standing on the Fondaco de' Turchi ; but the majority of the Gothic Palaces have the plain dog-tooth cornice under the tiled projecting roof (Vol. I. Chap. XIV. § iv.) ; and the highly decorated parapet is employed only on the tops of walls which surround courts or gardens, and which, without such decoration, would have been utterly devoid of interest. Fig.

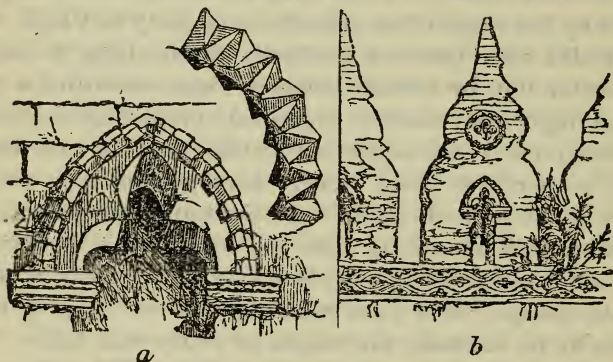

FIG. XXIII.

XXIII. represents, at *b*, part of a parapet of this kind which surrounds the court-yard of a palace in the Calle del Bagatin, between San G. Grisostomo, and San Canzian : the whole is of brick, and the mouldings peculiarly sharp and varied ; the height of each separate pinnacle being about four feet, crowning a wall twelve or fifteen feet high : a piece of the moulding which surrounds the quatrefoil is given larger in the figure at *a*, together with the top of the small arch below, having the common Venetian dentil round it, and a delicate little moulding with dog-tooth ornament to carry the flanks of the arch. The moulding of the brick is throughout sharp and beautiful in the highest degree. One of the most curious points about it is the careless way in which the curved outlines of the pin-

nacles are cut into the plain brickwork, with no regard whatever to the places of its joints. The weather of course wears the bricks at the exposed joints, and jags the outline a little ; but the work has stood, evidently from the fourteenth century, without sustaining much harm.

§ XIII. This parapet may be taken as a general type of the *wall*-parapet of Venice in the Gothic period ; some being much less decorated, and others much more richly : the most beautiful in Venice is in the little Calle, opening on the Campo and Traghetto San Samuele ; it has delicately carved devices in stone let into each pinnacle.

The parapets of the palaces themselves were lighter and more fantastic, consisting of narrow lance-like spires of marble, set between the broader pinnacles, which were in such cases generally carved into the form of a fleur-de-lis : the French word gives the reader the best idea of the form, though he must remember that this use of the lily for the parapets has nothing to do with France, but is the carrying out of the Byzantine system of floral ornamentation, which introduced the outline of the lily everywhere ; so that I have found it convenient to call its most beautiful capitals, the *lily* capitals of St. Mark's. But the occurrence of this flower, more distinctly than usual, on the battlements of the Ducal Palace, was the cause of some curious political speculation in the year 1511, when a piece of one of these battlements was shaken down by the great earthquake of that year. Sanuto notes in his diary that "the piece that fell was just that which bore the lily," and records sundry sinister anticipations, founded on this important omen, of impending danger to the adverse French power. As there happens, in the Ducal Palace, to be a joint in the pinnacles which exactly separates the "part which bears the lily" from that which is fastened to the cornice, it is no wonder that the omen proved fallacious.

§ XIV. The decorations of the parapet were completed by attaching gilded balls of metal to the extremities of the leaves of the lilies, and of the intermediate spires, so as literally to form for the wall a diadem of silver touched upon the points with gold ; the image being rendered still more distinct in the

Casa d' Oro, by variation in the height of the pinnacles, the highest being in the centre of the front.

Very few of these light roof parapets now remain ; they are, of course, the part of the building which dilapidation first renders it necessary to remove. That of the Ducal Palace, however, though often, I doubt not, restored, retains much of the ancient form, and is exceedingly beautiful, though it has no appearance from below of being intended for protection, but serves only, by its extreme lightness, to relieve the eye when wearied by the breadth of wall beneath ; it is nevertheless a most serviceable defence for any person walking along the edge of the roof. It has some appearance of insecurity, owing to the entire independence of the pieces of stone composing it, which, though of course fastened by iron, look as if they stood balanced on the cornice like the pillars of Stonehenge ; but I have never heard of its having been disturbed by anything short of an earthquake ; and, as we have seen, even the great earthquake of 1511, though it much injured the Gorne, or battlements at the Casa d'Oro, and threw down several statues at St. Mark's,* only shook one lily from the brow of the Ducal Palace.

§ xv. Although, however, these light and fantastic forms appear to have been universal in the battlements meant primarily for decoration, there was another condition of parapet altogether constructed for the protection of persons walking on the roofs or in the galleries of the churches, and from these more substantial and simple defences, the BALCONIES, to

* It is a curious proof how completely, even so early as the beginning of the sixteenth century, the Venetians had lost the habit of *reading* the religious art of their ancient churches, that Sanuto, describing this injury, says, that "four of the *Kings* in marble fell from their pinnacles above the front, at St. Mark's church ;" and presently afterwards corrects his mistake, and apologises for it thus : "These were four saints, St. Constantine, St. Demetrius, St. George, and St. Theodore, all Greek saints. *They look like Kings.*" Observe the perfect, because unintentional, praise given to the old sculptor.

I quote the passage from the translation of these precious diaries of Sanuto, by my friend Mr. Rawdon Brown, a translation which I hope will some day become a standard book in English libraries.

which the Gothic palaces owe half of their picturesque effect, were immediately derived ; the balcony being, in fact, nothing more than a portion of such roof parapets arranged round a projecting window-sill sustained on brackets, as in the central example of the annexed figure. We must, therefore, examine these defensive balustrades and the derivative balconies consecutively.

§ XVI. Obviously, a parapet with an unbroken edge, upon which the arm may rest (a condition above noticed, Vol. I. p. 166, as essential to the proper performance of its duty), can be constructed only in one of three ways. It must either be (1) of solid stone, decorated, if at all, by mere surface sculpture, as in the uppermost example in Fig. XXIV. ; or (2) pierced into some kind of tracery, as in the second ; or (3) composed of small pillars carrying a level bar of stone, as in the third ; this last condition being, in a diseased and swollen form, familiar to us in the balustrades of our bridges.*

§ XVII. (1.) Of these three kinds, the first, which is employed for the pulpit at Torcello and in the nave of St. Mark's, whence the uppermost example is taken, is beautiful when sculpture so rich can be employed upon it ; but it is liable to objection, first, because it is heavy and unlike a parapet when seen from below ; and, secondly, because it is inconvenient in use. The position of leaning over a balcony becomes cramped and painful if long continued, unless the foot can be sometimes advanced *beneath* the ledge on which the arm leans, i.e. between the balusters or traceries, which of course cannot be

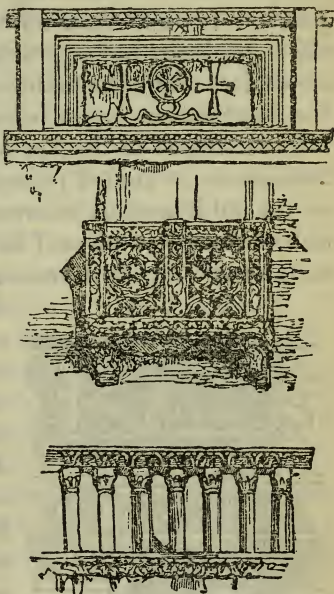

FIG. XXIV.

* I am not speaking here of iron balconies. See below, § XXII.

done in the solid parapet : it is also more agreeable to be able to see partially down through the penetrations, than to be obliged to lean far over the edge. The solid parapet was rarely used in Venice after the earlier ages.

§ XVIII. (2.) The Traceried Parapet is chiefly used in the Gothic of the North, from which the above example, in the Casa Contarini Fasan, is directly derived. It is, when well designed, the richest and most beautiful of all forms, and many of the best buildings of France and Germany are dependent for half their effect upon it ; its only fault being a slight tendency to fantasticism. It was never frankly received in Venice, where the architects had unfortunately returned to the Renaissance forms before the flamboyant parapets were fully developed in the North ; but, in the early stage of the Renaissance, a kind of pierced parapet was employed, founded on the old Byzantine interwoven traceries ; that is to say, the slab of stone was pierced here and there with holes, and then an interwoven pattern traced on the surface round them. The

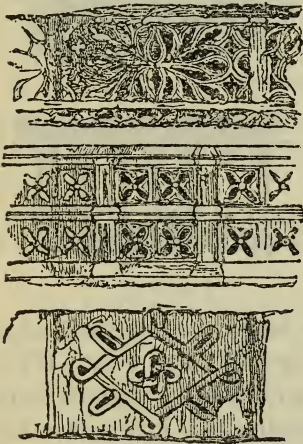

FIG. XXV.

difference in system will be understood in a moment by comparing the uppermost example in the figure at the side, which is a Northern parapet from the Cathedral of Abbeville, with the lowest, from a secret chamber in the Casa Foscari. It will be seen that the Venetian one is far more simple and severe, yet singularly piquant, the black penetrations telling sharply on the plain broad surface. Far inferior in beauty, it has yet one point of superiority to that of Abbeville, that it proclaims itself more definitely to be stone. The other has rather the look of lace.

The intermediate figure is a panel of the main balcony of the Ducal Palace, and is introduced here as being an exactly transitional condition between the Northern and Venetian

types. It was built when the German Gothic workmen were exercising considerable influence over those in Venice, and there was some chance of the Northern parapet introducing itself. It actually did so, as above shown, in the Casa Contarini Fasani, but was for the most part stoutly resisted and kept at bay by the Byzantine form, the lowest in the last figure, until that form itself was displaced by the common, vulgar, Renaissance baluster; a grievous loss, for the severe pierced type was capable of a variety as endless as the fantasticism of our own Anglo-Saxon manuscript ornamentation.

§ XIX. (3.) The Baluster Parapet. Long before the idea of tracery had suggested itself to the minds either of Venetian or any other architects, it had, of course, been necessary to provide protection for galleries, edges of roofs, &c.; and the most natural form in which such protection could be obtained was that of a horizontal bar or hand-rail, sustained upon short shafts or balusters, as in Fig. XXIV. p. 243. This form was, above all others, likely to be adopted where variations of Greek or Roman pillared architecture were universal in the larger masses of the building; the parapet became itself a small series of columns, with capitals and architraves; and whether the cross-bar laid upon them should be simply horizontal, and in contact with their capitals, or sustained by mimic arches, round or pointed, depended entirely on the system adopted in the rest of the work. Where the large arches were round, the small balustrade arches would be so likewise; where those were pointed, these would become so in sympathy with them.

§ XX. Unfortunately, wherever a balcony or parapet is used in an inhabited house, it is, of course, the part of the structure which first suffers from dilapidation, as well as that of which the security is most anxiously cared for. The main pillars of a casement may stand for centuries unshaken under the steady weight of the superincumbent wall, but the cement and various inseting of the balconies are sure to be disturbed by the irregular pressures and impulses of the persons leaning on them; while, whatever extremity of decay may be allowed in other parts of the building, the balcony, as soon as it seems

dangerous, will assuredly be removed or restored. The reader will not, if he considers this, be surprised to hear that, among all the remnants of the Venetian domestic architecture of the eleventh, twelfth, and thirteenth centuries, there is not a single instance of the original balconies being preserved. The palace mentioned below (§ xxxii.), in the piazza of the Rialto, has, indeed, solid slabs of stone between its shafts, but I cannot be certain that they are of the same period ; if they are, this is the only existing example of the form of protection employed for casements during this transitional period, and it cannot be reasoned from as being the general one.

§ xxi. It is only, therefore, in the churches of Torcello, Murano, and St. Mark's, that the ancient forms of gallery defence may still be seen. At Murano, between the pillars of the apse, a beautiful balustrade is employed, of which a single arch is given in the Plate opposite, fig. 4, with its section, fig. 5. ; and at St. Mark's, a noble round-arched parapet, with small pillars of precisely the same form as those of Murano, but shorter, and bound at the angles into groups of four by the serpentine knot so often occurring in Lombardic work, runs round the whole exterior of the lower story of the church, and round great part of its interior galleries, alternating with the more fantastic form, fig. 6. In domestic architecture, the remains of the original balconies begin to occur first in the beginning of the fourteenth century, when the round arch had entirely disappeared ; and the parapet consists, almost without exception, of a series of small trefoiled arches, cut boldly through a bar of stone which rests upon the shafts, at first very simple, and generally adorned with a cross at the point of each arch, as in fig. 7 in the last Plate, which gives the angle of such a balcony on a large scale ; but soon enriched into the beautiful conditions, figs. 2 and 3, and sustained on brackets formed of lions' heads, as seen in the central example of their entire effect, fig. 1.

§ xxii. In later periods, the round arches return ; then the interwoven Byzantine form ; and finally, as above noticed, the common English or classical balustrade ; of which, however, exquisite examples, for grace and variety of outline, are found

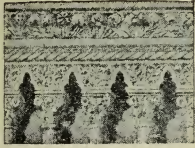

2

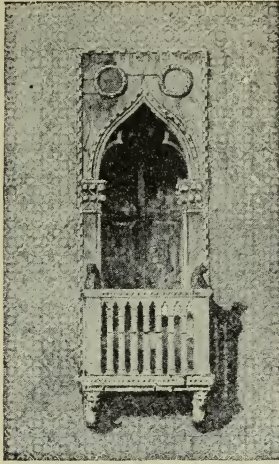

1

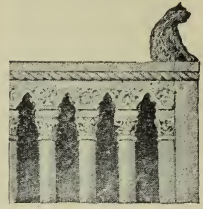

3

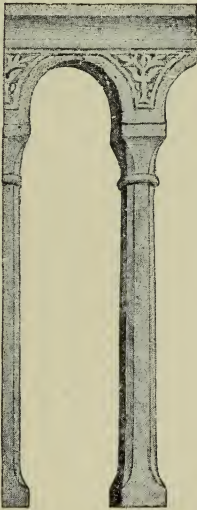

4



5

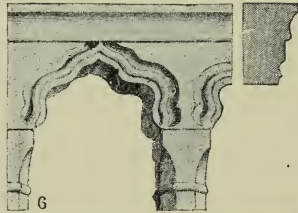

6

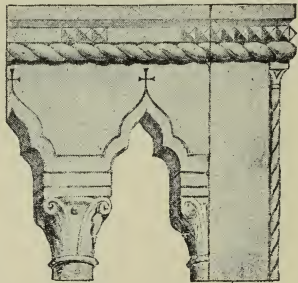

7

PLATE XIII.—BALCONIES.

designed in the backgrounds of Paul Veronese. I could willingly follow out this subject fully, but it is impossible to do so without leaving Venice ; for the chief city of Italy, as far as regards the strict effect of the balcony, is Verona ; and if we were once to lose ourselves among the sweet shadows of its lonely streets, where the falling branches of the flowers stream like fountains through the pierced traceries of the marble, there is no saying whether we might soon be able to return to our immediate work. Yet before leaving the subject of the balcony * altogether, I must allude, for a moment, to the peculiar treatment of the iron-work out of which it is frequently wrought on the mainland of Italy—never in Venice. The iron is always wrought, not cast, beaten first into thin leaves, and then cut either into strips or bands, two or three inches broad, which are bent into various curves to form the sides of the balcony, or else into actual leafage, sweeping and free, like the leaves of nature, with which it is richly decorated. There is no end to the variety of design, no limit to the lightness and flow of the forms, which the workman can produce out of iron treated in this manner ; and it is very nearly as impossible for any metal-work, so handled, to be poor, or ignoble in effect, as it is for cast metal-work to be otherwise.

§ XXIII. We have next to examine those features of the Gothic palaces in which the transitions of their architecture are most distinctly traceable ; namely, the arches of the windows and doors.

It has already been repeatedly stated, that the Gothic style had formed itself completely on the mainland, while the Byzantines still retained their influence at Venice ; and that the history of early Venetian Gothic is therefore not that of a school taking new forms independently of external influence, but the history of the struggle of the Byzantine manner with a contemporary style quite as perfectly organized as itself, and far more energetic. And this struggle is exhibited partly in the gradual change of the Byzantine architecture into other

* Some details respecting the mechanical structure of the Venetian balcony are given in the final Appendix.

forms, and partly by isolated examples of genuine Gothic taken prisoner, as it were, in the contest ; or rather entangled among the enemy's forces, and maintaining their ground till their friends came up to sustain them. Let us first follow the steps of the gradual change, and then give some brief account of the various advanced guards and forlorn hopes of the Gothic attacking force.

§ xxiv. The uppermost shaded series of six forms of windows in Plate XIV., opposite, represents, at a glance, the modifications of this feature in Venetian palaces, from the eleventh to the fifteenth century. Fig. 1 is Byzantine, of the eleventh and twelfth centuries ; figs. 2 and 3 transitional, of the thirteenth and early fourteenth centuries ; figs. 4 and 5 pure Gothic of the thirteenth, fourteenth and early fifteenth ; and fig. 6 late Gothic, of the fifteenth century, distinguished by its added finial. Fig. 4 is the longest-lived of all these forms. It occurs first in the thirteenth century ; and, sustaining modifications only in its mouldings, is found also in the middle of the fifteenth.

I shall call these the six orders* of Venetian windows, and when I speak of a window of the fourth, second, or sixth order, the reader will only have to refer to the numerals at the top of Plate XIV.

Then the series below shows the principal forms found in each period, belonging to each several order ; except 1 *b* to 1 *c*, and the two lower series, numbered 7 to 16, which are types of Venetian doors.

* I found it convenient in my own memoranda to express them simply as fourths, seconds, &c. But "order" is an excellent word for any known group of forms, whether of windows, capitals, bases, mouldings, or any other architectural feature, provided always that it be not understood in any wise to imply preëminence or isolation in these groups. Thus I may rationally speak of the six orders of Venetian windows, provided I am ready to allow a French architect to speak of the six or seven, or eight, or seventy or eighty, orders of Norman windows, if so many are distinguishable ; and so also we may rationally speak, for the sake of intelligibility, of the five orders of Greek pillars, provided only we understand that there may be five millions of orders as good or better, of pillars *not* Greek.

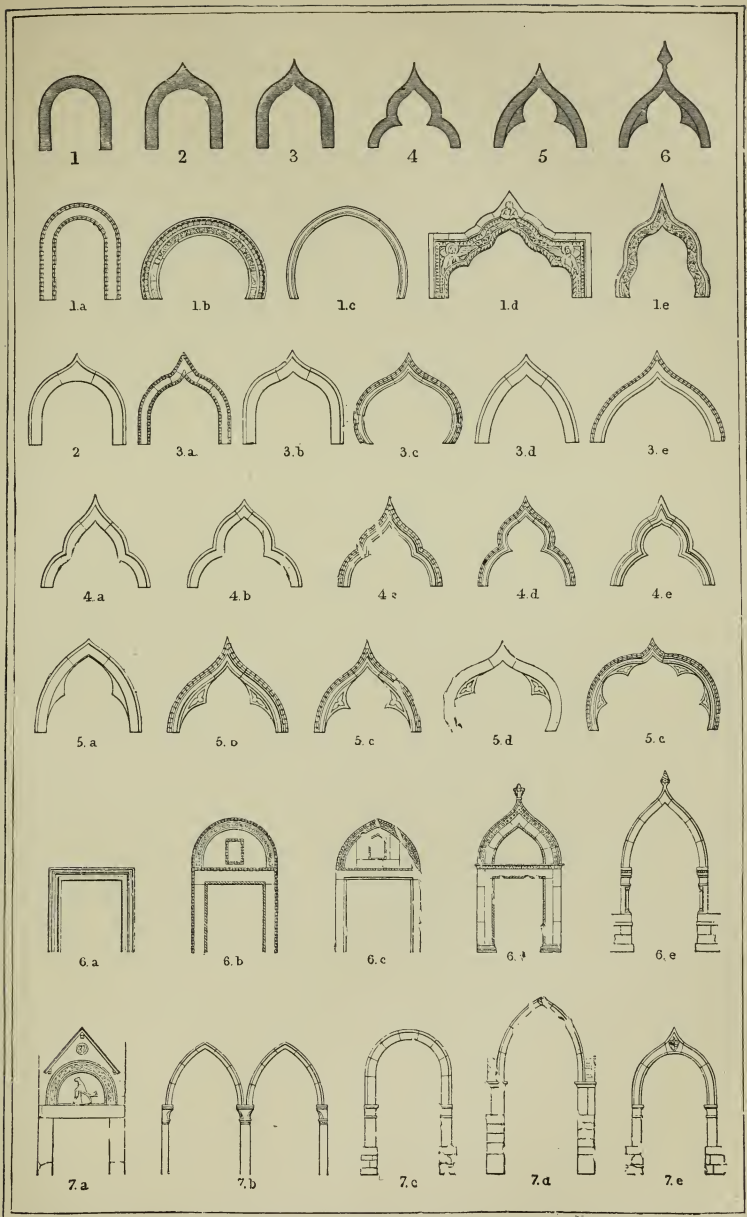

PLATE XIV.--THE ORDERS OF VENETIAN ARCHES.

§ xxv. We shall now be able, without any difficulty, to follow the course of transition, beginning with the first order, 1 and 1 *a*, in the second row. The horse-shoe arch, 1 *b*, is the door-head commonly associated with it, and the other three in the same row occur in St. Mark's exclusively ; 1 *c* being used in the nave, in order to give a greater appearance of lightness to its great lateral arcades, which at first the spectator supposes to be round-arched, but he is struck by a peculiar grace and elasticity in the curves for which he is unable to account, until he ascends into the galleries whence the true form of the arch is discernible. The other two—1 *d*, from the door of the southern transept, and 1 *c*, from that of the treasury,—sufficiently represent a group of fantastic forms derived from the Arabs, and of which the exquisite decoration is one of the most important features in St. Mark's. Their form is indeed permitted merely to obtain more fantasy in the curves of this decoration.* The reader can see in a moment, that, as pieces of masonry, or bearing arches, they are infirm or useless, and therefore never could be employed in any building in which dignity of structure was the primal object. It is just because structure is *not* the primal object in St. Mark's, because it has no severe weights to bear, and much loveliness of marble and sculpture to exhibit, that they are therein allowable. They are of course, like the rest of the building, built of brick and faced with marble, and their inner masonry, which must be very ingenious, is therefore not discernible. They have settled a little, as might have been expected, and the consequence is, that there is in every one of them, except the upright arch of the treasury, a small fissure across the marble of the flanks.

§ xxvi. Though, however, the Venetian builders adopted these Arabian forms of arch where grace of ornamentation was their only purpose, they saw that such arrangements were unfit for ordinary work ; and there is no instance, I believe, in Venice, of their having used any of them for a dwelling-house in the truly Byzantine period. But so soon as the Gothic influence began to be felt, and the pointed arch forced itself

* Or in their own curves ; as, on a small scale, in the balustrade fig. 6, Plate XIII., above.

upon them, their first concession to its attack was the adoption, in preference to the round arch, of the form 3 *a* (Plate XIV., above); the point of the Gothic arch forcing itself up, as it were, through the top of the semicircle which it was soon to supersede.

§ XXVII. The woodcut, Fig. XXVI., represents the door and two of the lateral windows of a house in the Corte del Remer, facing the Grand Canal, in the parish of the Apostoli. It is remarkable as having its great entrance on the first floor, attained by a bold flight of steps, sustained on pure *pointed* arches wrought in brick. I cannot tell if these arches

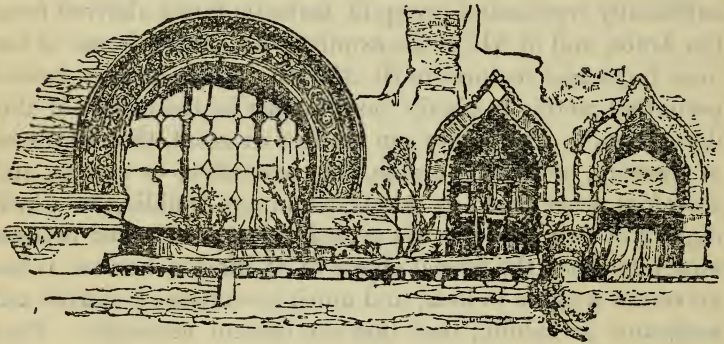

FIG. XXVI.

are contemporary with the building, though it must always have had an access of the kind. The rest of its aspect is Byzantine, except only that the rich sculptures of its archivolt show in combats of animals, beneath the soffit, a beginning of the Gothic fire and energy. The moulding of its plinth is of a Gothic profile,* and the windows are pointed, not with a reversed curve, but in a pure straight gable, very curiously contrasted with the delicate bending of the pieces of marble armor cut for the shoulders of each arch. There is a two-lighted window, such as that seen in the vignette, on each side of the door, sustained in the centre by a basket-worked

* For all details of this kind, the reader is referred to the final Appendix in Vol. III.

Byzantine capital: the mode of covering the brick archivolt with marble, both in the windows and doorway, is precisely like that of the true Byzantine palaces.

§ XXVIII. But as, even on a small scale, these arches are weak, if executed in brickwork, the appearance of this sharp point in the outline was rapidly accompanied by a parallel change in the method of building; and instead of constructing the arch of brick and coating it with marble, the builders formed it of three pieces of hewn stone inserted in the wall, as in Fig. XXVII. Not, however, at first in this perfect form. The endeavor to reconcile the grace of the reversed arch with the strength of the round one, and still to build in brick, ended at first in conditions such as that represented at *a*, Fig. XXVIII,



FIG. XXVII.

*a**b*

FIG. XXVIII.

which is a window in the Calle del Pistor, close to the church of the Apostoli, a very interesting and perfect example. Here, observe, the poor round arch is still kept to do all the hard work, and the fantastic ogee takes its pleasure above, in the form of a moulding merely, a chain of bricks cast to the required curve. And this condition, translated into stone-work, becomes a window of the second order (*b*, Fig. XXVIII., or 2, in Plate XIV.); a form perfectly strong and serviceable, and of immense importance in the transitional architecture of Venice.

§ XXIX. At *b*, Fig. XXVIII., as above, is given one of the earliest and simplest occurrences of the second order window

(in a double group, exactly like the brick transitional form *a*). from a most important fragment of a defaced house in the Salizzada San Lio, close to the Merceria. It is associated with a fine *pointed* brick arch, indisputably of contemporary work, towards the close of the thirteenth century, and it is shown to be later than the previous example, *a*, by the greater development of its mouldings. The archivolt profile, indeed, is the simpler of the two, not having the sub-

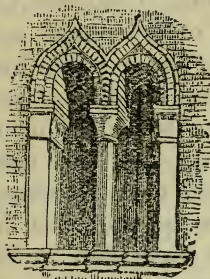
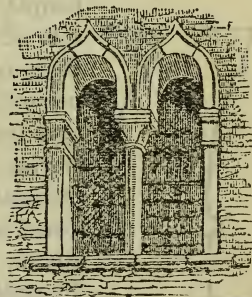
arch ; as in the brick example ; but the other mouldings are far more developed. Fig. XXIX. shows at 1 the arch profiles, at 2 the capital profiles, at 3 the basic-plinth profiles, of each window, *a* and *b*.



FIG. XXIX.

§ xxx. But the second order window soon attained nobler development. At once simple, graceful, and strong, it was received into all the architecture of the period, and there is hardly a street in Venice which does not exhibit some important remains of palaces built with this form of window in many stories, and in numerous groups. The most extensive and perfect is one upon the Grand Canal in the parish of the Apostoli, near the Rialto, covered with rich decoration, in the Byzantine manner, between the windows of its first story ; but not completely characteristic of the transitional period, because still retaining the dentil in the arch mouldings, while the transitional houses all have the simple roll. Of the fully established type, one of the most extensive and perfect exam-

ples is in a court in the Calle di Rimedio, close to the Ponte dell' Angelo, near St. Mark's Place. Another looks out upon a small square garden, one of the few visible in the centre of Venice, close by the Corte Salviati (the latter being known to every cicerone as that from which Bianca Capello fled). But, on the whole, the most interesting to the traveller is that of which I have given a vignette opposite.

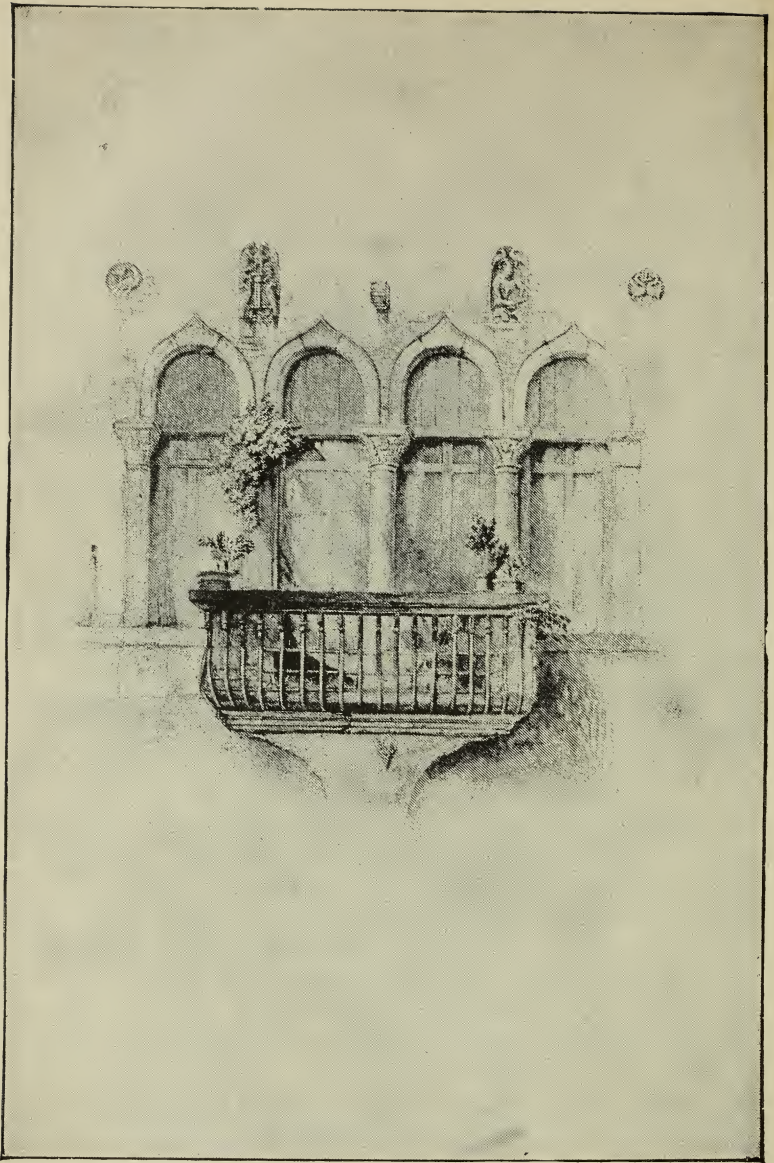

PLATE XV.—WINDOWS OF THE SECOND ORDER. CASA FALIER.

But for this range of windows, the little piazza SS. Apostoli would be one of the least picturesque in Venice; to those, however, who seek it on foot, it becomes geographically interesting from the extraordinary involution of the alleys leading to it from the Rialto. In Venice, the straight road is usually by water, and the long road by land; but the difference of distance appears, in this case, altogether inexplicable. Twenty or thirty strokes of the oar will bring a gondola from the foot of the Rialto to that of the Ponte SS. Apostoli; but the unwise pedestrian, who has not noticed the white clue beneath his feet,* may think himself fortunate, if, after a quarter of an hour's wandering among the houses behind the Fondaco de' Tedeschi, he finds himself anywhere in the neighborhood of the point he seeks. With much patience, however, and modest following of the guidance of the marble thread, he will at last emerge over a steep bridge into the open space of the Piazza, rendered cheerful in autumn by a perpetual market of pomegranates, and purple gourds, like enormous black figs; while the canal, at its extremity, is half-blocked up by barges laden with vast baskets of grapes as black as charcoal, thatched over with their own leaves.

Looking back, on the other side of this canal, he will see the windows represented in Plate XV., which, with the arcade of pointed arches beneath them, are the remains of the palace once belonging to the unhappy doge, Marino Faliero.

The balcony is, of course, modern, and the series of windows has been of greater extent, once terminated by a pilaster on the left hand, as well as on the right; but the terminal arches have been walled up. What remains, however, is enough, with its sculptured birds and dragons, to give the reader a very distinct idea of the second order window in its

* Two threads of white marble, each about an inch wide, inlaid in the dark grey pavement, indicate the road to the Rialto from the farthest extremity of the north quarter of Venice. The peasant or traveller, lost in the intricacy of the pathway in this portion of the city, cannot fail, after a few experimental traverses, to cross these white lines, which thenceforward he has nothing to do but to follow, though their capricious sinuosities will try his patience not a little.

perfect form. The details of the capitals, and other minor portions, if these interest him, he will find given in the final Appendix.

§ xxxi. The advance of the Gothic spirit was, for a few years, checked by this compromise between the round and pointed arch. The truce, however, was at last broken, in consequence of the discovery that the keystone would do duty quite as well in the form *b* as in the form *a*, Fig. XXX., and the substitution of *b*, at the head of the arch, gives us the window of the third order, 3 *b*, 3 *d*, and 3 *e*, in Plate XIV. The forms 3 *a* and 3 *c* are exceptional; the first occurring, as we have

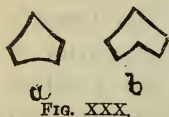

seen, in the Corte del Remer, and in one other palace on the Grand Canal, close to the Church of St. Eustachio; the second only, as far as I know, in one house on the Cana-Reggio, belonging to the true Gothic period. The other three examples, 3 *b*, 3 *d*, 3 *e*, are generally characteristic of the third order; and it will be observed that they differ not merely in mouldings, but in slope of sides, and this latter difference is by far the most material. For in the example 3 *b* there is hardly any true Gothic expression; it is still the pure Byzantine arch, with a point thrust up through it: but the moment the flanks slope, as in 3 *d*, the Gothic expression is definite, and the entire school of the architecture is changed.

This slope of the flanks occurs, first, in so slight a degree as to be hardly perceptible, and gradually increases until, reaching the form 3 *e* at the close of the thirteenth century, the window is perfectly prepared for a transition into the fifth order.

§ xxxii. The most perfect examples of the third order in Venice are the windows of the ruined palace of Marco Querini, the father-in-law of Bajamonte Tiepolo, in consequence of whose conspiracy against the government this palace was ordered to be razed in 1310; but it was only partially ruined, and was afterwards used as the common shambles. The Venetians have now made a poultry market of the lower story (the shambles being removed to a suburb), and a prison of the upper, though it is one of the most important and interesting

monuments in the city, and especially valuable as giving us a secure date for the central form of these very rare transitional windows. For, as it was the palace of the father-in-law of Bajamonte, and the later was old enough to assume the leadership of a political faction in 1280,* the date of the accession to the throne of the Doge Pietro Gradenigo, we are secure of this palace having been built not later than the middle of the thirteenth century. Another example, less refined in workmanship, but, if possible, still more interesting, owing to the

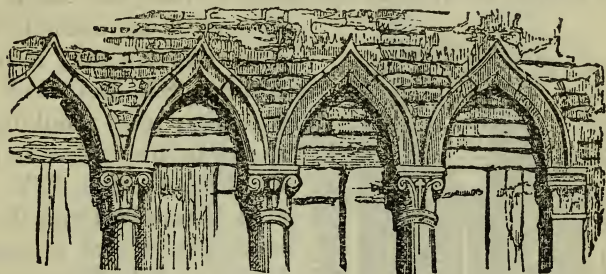

FIG. XXXI.

variety of its capitals, remains in the little piazza opening to the Rialto, on the St. Mark's side of the Grand Canal. The house faces the bridge, and its second story has been built in the thirteenth century, above a still earlier Byzantine cornice remaining, or perhaps introduced from some other ruined edifice, in the walls of the first floor. The windows of the second story are of pure third order; four of them are represented above, with their flanking pilaster, and capitals varying constantly in the form of the flower or leaf introduced between their volutes.

§ xxxiii. Another most important example exists in the lower story of the Casa Sagredo, on the Grand Canal, remarkable as having the early upright form (3 *b*, Plate XIV.) with a somewhat late moulding. Many others occur in the fragmentary ruins in the streets: but the two boldest conditions

* An account of the conspiracy of Bajamonte may be found in almost any Venetian history; the reader may consult Mutinelli, *Annali Urbani*, lib. iii.

which I found in Venice are those of the Chapter-House of the Frari, in which the Doge Francesco Dandolo was buried circa 1339 ; and those of the flank of the Ducal Palace itself absolutely corresponding with those of the Frari, and therefore of inestimable value in determining the date of the palace. Of these more hereafter.

§ xxxiv. Contemporarily with these windows of the second and third orders, those of the fourth (*4 a* and *4 b*, in Plate XIV.) occur, at first in pairs, and with simple mouldings, precisely similar to those of the second order, but much more

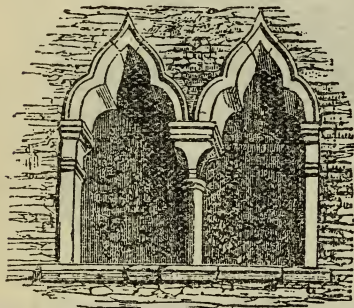

FIG. XXXII.

rare, as in the example at the side, Fig. XXXII., from the Salizada San Liò ; and then, enriching their mouldings as shown in the continuous series *4 c*, *4 d*, of Plate XIV., associate themselves with the fifth order windows of the perfect Gothic period. There is hardly a palace in Venice without some example, either early or late, of these fourth order win-

dows ; but the Plate opposite (XVI.) represents one of their purest groups at the close of the thirteenth century, from a house on the Grand Canal, nearly opposite the Church of the Scalzi. I have drawn it from the side, in order that the great depth of the arches may be seen, and the clear detaching of the shafts from the sheets of glass behind. The latter, as well as the balcony, are comparatively modern ; but there is no doubt that if glass were used in the old window, it was set behind the shafts, at the same depth. The entire modification of the interiors of all the Venetian houses by recent work has however prevented me from entering into any inquiry as to the manner in which the ancient glazing was attached to the interiors of the windows.

The fourth order window is found in great richness and beauty at Verona, down to the latest Gothic times, as well as in the earliest, being then more frequent than any other form.



PLATE XVI.—WINDOWS OF THE FOURTH ORDER.

It occurs, on a grand scale, in the old palace of the Scaligers, and profusely throughout the streets of the city. The series 4 *a* to 4 *e*, Plate XIV., shows its most ordinary conditions and changes of arch-line: 4 *a* and 4 *b* are the early Venetian forms; 4 *c*, later, is general at Venice; 4 *d*, the best and most piquant condition, owing to its fantastic and bold projection of cusp, is common to Venice and Verona; 4 *e* is early Veronese.

§ xxxv. The reader will see at once, in descending to the fifth row in Plate XIV., representing the windows of the fifth order, that they are nothing more than a combination of the third and fourth. By this union they become the nearest approximation to a perfect Gothic form which occurs characteristically at Venice; and we shall therefore pause on the threshold of this final change, to glance back upon, and gather together, those fragments of purer pointed architecture which were above noticed as the forlorn hopes of the Gothic assault.

The little Campiello San Rocco is entered by a sotto-portico behind the church of the Frari. Looking back, the upper traceries of the magnificent apse are seen towering above the irregular roofs and chimneys of the little square; and our lost Prout was enabled to bring the whole subject into an exquisitely picturesque composition, by the fortunate occurrence of four quaint trefoiled windows in one of the houses on the right. Those trefoils are among the most ancient efforts of Gothic art in Venice. I have given a rude sketch of them in Fig. XXXIII. They are built entirely of brick, except the central shaft and capital, which are of Istrian stone. Their structure is the simplest possible; the trefoils being cut out of the radiating bricks which form the pointed arch, and the edge or upper limit of that pointed arch indicated by a roll moulding formed of cast bricks, in length of about a foot, and ground at the bottom so as to meet in one, as in Fig. XXXIV. The capital of the shaft is one of the earliest transitional forms;* and observe the curious following out, even in this minor instance, of the great law of centralization above ex-

* See account of series of capitals in final Appendix.

plained with respect to the Byzantine palaces. There is a central shaft, a pilaster on each side, and then the wall. The pilaster has, by way of capital, a square flat brick, projecting a little, and cast, at the edge, into the form of the first type of all cornices (*a*, p. 75, Vol. I.; the reader ought to glance back at this passage, if he has forgotten it); and the shafts and pilasters all stand, without any added bases, on a projecting plinth of the same simple profile. These windows have

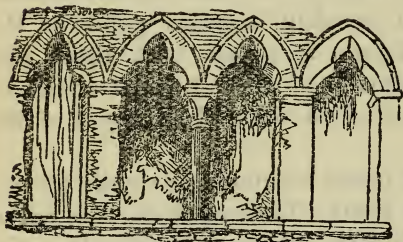

FIG. XXXIII.

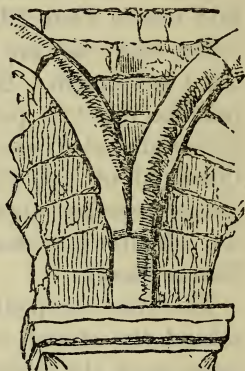

FIG. XXXIV.

been much defaced; but I have not the least doubt that their plinths are the original ones: and the whole group is one of the most valuable in Venice, as showing the way in which the humblest houses, in the noble times, followed out the system of the larger palaces, as far as they could, in their rude materials. It is not often that the dwellings of the lower orders are preserved to us from the thirteenth century.

§ xxxvi. In the two upper lines of the opposite Plate (XVII.), I have arranged some of the more delicate and finished examples of Gothic work of this period. Of these, fig. 4 is taken from the outer arcade of San Fermo of Verona, to show the condition of mainland architecture, from which all these Venetian types were borrowed. This arch, together with the rest of the arcade, is wrought in fine stone, with a band of inlaid red brick, the whole chiselled and fitted with exquisite precision, all Venetian work being coarse in com-

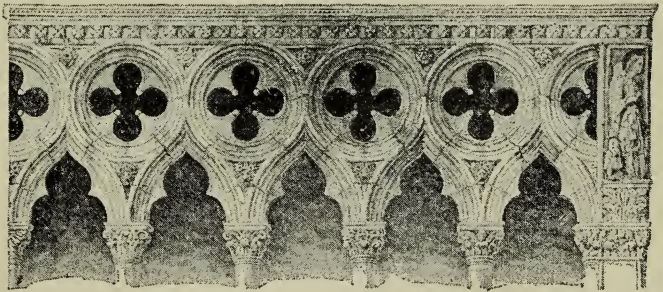
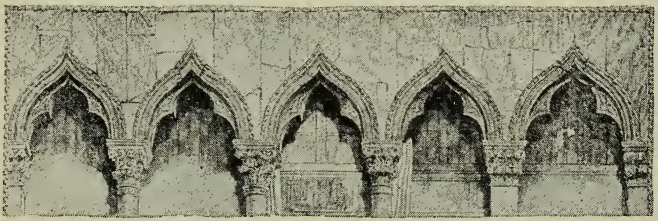
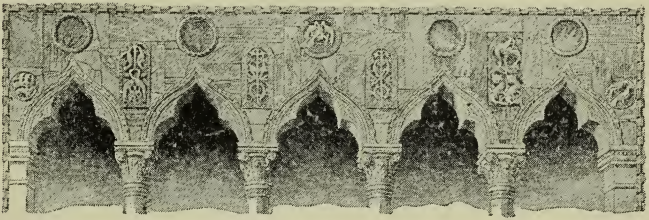

PLATE XVII.—WINDOWS OF THE EARLY GOTHIC PALACES.

parison. Throughout the streets of Verona, arches and windows of the thirteenth century are of continual occurrence, wrought, in this manner, with brick and stone; sometimes the brick alternating with the stones of the arch, as in the finished example given in Plate XIX. of the first volume, and there selected in preference to other examples of archivolt decoration, because furnishing a complete type of the master school from which the Venetian Gothic is derived.

§ xxxvii. The arch from St. Fermo, however, fig. 4, Plate XVII., corresponds more closely, in its entire simplicity, with the little windows from the Campiello San Rocco; and with the type 5 set beside it in Plate XVII., from a very ancient house in the Corte del Forno at Santa Marina (all in brick); while the upper examples, 1 and 2, show the use of the flat but highly enriched architrave, for the connection of which with Byzantine work see the final Appendix, Vol. III., under the head "Archivolt." These windows (figs. 1 and 2, Plate XVII.) are from a narrow alley in a part of Venice now exclusively inhabited by the lower orders, close to the arsenal;* they are entirely wrought in brick, with exquisite mouldings, not cast, but *moulded in the clay by the hand*, so that there is not one piece of the arch like another; the pilasters and shafts being, as usual, of stone.

§ xxxviii. And here let me pause for a moment, to note what one should have thought was well enough known in England,—yet I could not perhaps touch upon anything less considered,—the real use of brick. Our fields of good clay were never given us to be made into oblong morsels of one size. They were given us that we might play with them, and that men who could not handle a chisel, might knead out of them some expression of human thought. In the ancient architecture of the clay districts of Italy, every possible

* If the traveller desire to find them (and they are worth seeking), let him row from the Fondamenta S. Biagio down the Rio della Tana; and look, on his right, for a low house with windows in it like those in the woodcut No. XXXI. above, p. 255. Let him go in at the door of the portico in the middle of this house, and he will find himself in a small alley, with the windows in question on each side of him.

adaptation of the material is found exemplified: from the coarsest and most brittle kinds, used in the mass of the structure, to bricks for arches and plinths, cast in the most perfect curves, and of almost every size, strength, and hardness; and moulded bricks, wrought into flower-work and tracery as fine as raised patterns upon china. And, just as many of the finest works of the Italian sculptors were executed in porcelain, many of the best thoughts of their architects are expressed in brick, or in the softer material of terra cotta; and if this were so in Italy, where there is not one city from whose towers we may not descry the blue outline of Alp or Apennine, everlasting quarries of granite or marble, how much more ought it to be so among the fields of England! I believe that the best academy for her architects, for some half century to come, would be the brick-field; for of this they may rest assured, that till they know how to use clay, they will never know how to use marble.

§ xxxix. And now observe, as we pass from fig. 2 to fig. 3, and from fig. 5 to fig. 6, in Plate XVII., a most interesting step of transition. As we saw above, § xiv., the round arch yielding to the Gothic, by allowing a point to emerge at its summit, so here we have the Gothic conceding something to the form which had been assumed by the round; and itself slightly altering its outline so as to meet the condescension of the round arch half way. At page 142 of the first volume, I have drawn to scale one of these minute concessions of the pointed arch, granted at Verona out of pure courtesy to the Venetian forms, by one of the purest Gothic ornaments in the world; and the small window here, fig. 6, is a similar example at Venice itself, from the Campo Santa Maria Mater Domini, where the reversed curve at the head of the pointed arch is just perceptible and no more. The other examples, figs. 3 and 7, the first from a small but very noble house in the Merceria, the second from an isolated palace at Murano, show more advanced conditions of the reversed curve, which, though still employing the broad decorated architrave of the earlier examples, are in all other respects prepared for the transition to the simple window of the fifth order.

§ XL. The next example, the uppermost of the three lower series in Plate XVII., shows this order in its early purity; associated with intermediate decorations like those of the Byzantines, from a palace once belonging to the Erizzo family, near the Arsenal. The ornaments appear to be actually of Greek workmanship (except, perhaps, the two birds over the central arch, which are bolder, and more free in treatment), and built into the Gothic fronts; showing, however, the early date of the whole by the manner of their insertion, corresponding exactly with that employed in the Byzantine palaces, and by the covering of the intermediate spaces with sheets of marble, which, however, instead of being laid over the entire wall, are now confined to the immediate spaces between and above the windows, and are bounded by a dentil moulding.

In the example below this the Byzantine ornamentation has vanished, and the fifth order window is seen in its generic form, as commonly employed throughout the early Gothic period. Such arcades are of perpetual occurrence; the one in the Plate was taken from a small palace on the Grand Canal, nearly opposite the Casa Foscari. One point in it deserves especial notice, the increased size of the lateral window as compared with the rest: a circumstance which occurs in a great number of the groups of windows belonging to this period, and for which I have never been able to account.

§ XLI. Both these figures have been most carefully engraved; and the uppermost will give the reader a perfectly faithful idea of the general effect of the Byzantine sculptures, and of the varied alabaster among which they are inlaid, as well as of the manner in which these pieces are set together, every joint having been drawn on the spot: and the transition from the embroidered and silvery richness of this architecture, in which the Byzantine ornamentation was associated with the Gothic form of arch, to the simplicity of the pure Gothic arcade as seen in the lower figure, is one of the most remarkable phenomena in the history of Venetian art. If it had occurred suddenly, and at an earlier period, it might have been traced partly to the hatred of the Greeks, consequent

upon the treachery of Manuel Comnenus,* and the fatal war to which it led ; but the change takes place gradually, and not till a much later period. I hoped to have been able to make some careful inquiries into the habits of domestic life of the Venetians before and after the dissolution of their friendly relations with Constantinople ; but the labor necessary for the execution of my more immediate task has entirely prevented this : and I must be content to lay the succession of the architectural styles plainly before the reader, and leave the collateral questions to the investigation of others ; merely noting this one assured fact, that *the root of all that is greatest in Christian art is struck in the thirteenth century* ; that the temper of that century is the life-blood of all manly work thenceforward in Europe ; and I suppose that one of its peculiar characteristics was elsewhere, as assuredly in Florence, a singular simplicity in domestic life :

“ I saw Bellincion Berti walk abroad
 In leathern girdle, and a clasp of bone ;
 And, with no artful coloring on her cheeks,
 His lady leave the glass. The sons I saw
 Of Verli and of Vecchio, well content
 With unrobed jerkin, and their good dames handling
 The spindle and the flax.
 One waked to tend the cradle, hushing it
 With sounds that lulled the parents' infancy ;
 Another, with her maidens, drawing off
 The tresses from the distaff, lectured them
 Old tales of Troy, and Fesole, and Rome.” †

* The bitterness of feeling with which the Venetians must have remembered this, was probably the cause of their magnificent heroism in the final siege of the city under Dandolo, and, partly, of the excesses which disgraced their victory. The conduct of the allied army of the Crusaders on this occasion cannot, however, be brought in evidence of general barbarism in the thirteenth century : first, because the masses of the crusading armies were in great part composed of the refuse of the nations of Europe ; and secondly, because such a mode of argument might lead us to inconvenient conclusions respecting ourselves, so long as the horses of the Austrian cavalry are stabled in the cloister of the convent which contains the Last Supper of Leonardo da Vinci. See Appendix 3, Vol. III. : “ Austrian Government in Italy.”

† It is generally better to read ten lines of any poet in the original

§ XLII. Such, then, is the simple fact at Venice, that from the beginning of the thirteenth century there is found a singular increase of simplicity in all architectural ornamentation; the rich Byzantine capitals giving place to a pure and severe type hereafter to be described,* and the rich sculptures vanishing from the walls, nothing but the marble facing remaining. One of the most interesting examples of this transitional state is a palace at San Severo, just behind the Casa Zorzi. This latter is a Renaissance building, utterly worthless in every respect, but known to the Venetian Ciceroni; and by inquiring for it, and passing a little beyond it down the Fondamenta San Severo, the traveller will see, on the other side of the canal, a palace which the Ciceroni never notice, but which is unique in Venice for the magnificence of the veined purple alabasters with which it has been decorated, and for the manly simplicity of the foliage of its capitals. Except in these, it has no sculpture whatever, and its effect is dependent entirely on color. Disks of green serpentine are inlaid on the field of purple alabaster; and the pillars are alternately of red marble with white capitals, and of white marble with red capitals. Its windows appear of the third order; and the back of the palace, in a small and most picturesque court, shows a group of windows which are, perhaps, the most superb examples of that order in Venice. But the windows to the front have, I think, been of the fifth order, and their cusps have been cut away.

§ XLIII. When the Gothic feeling began more decidedly to language, however painfully, than ten cantos of a translation. But an exception may be made in favor of Cary's Dante. If no poet ever was liable to lose more in translation, none was ever so carefully translated; and I hardly know whether most to admire the rigid fidelity, or the sweet and solemn harmony, of Cary's verse. There is hardly a fault in the fragment quoted above, except the word "lectured," for Dante's beautiful "favoleggiava;" and even in this case, joining the first words of the following line, the translation is strictly literal. It is true that the conciseness and the rivulet-like melody of Dante must continually be lost; but if I could only read English, and had to choose, for a library narrowed by poverty, between Cary's Dante and our own original Milton, I should choose Cary without an instant's pause.

* See final Appendix, Vol. III., under head "Capitals."

establish itself, it evidently became a question with the Venetian builders, how the intervals between the arches, now left blank by the abandonment of the Byzantine sculptures, should be enriched in accordance with the principles of the new school. Two most important examples are left of the experiments made at this period: one at the Ponte del Forner, at San Cassano, a noble house in which the spandrils of the windows are filled by the emblems of the four Evangelists, sculptured in deep relief, and touching the edges of the arches with their expanded wings; the other now known as the Palazzo Cicogna, near the church of San Sebastiano, in the quarter called "of the Archangel Raphael," in which a large space of wall above the windows is occupied by an intricate but rude tracery of involved quatrefoils. Of both these palaces I purposed to give drawings in my folio work; but I shall probably be saved the trouble by the publication of the beautiful calotypes lately made at Venice of both; and it is unnecessary to represent them here, as they are unique in Venetian architecture, with the single exception of an unimportant imitation of the first of them in a little by-street close to the Campo Sta. Maria Formosa. For the question as to the mode of decorating the interval between the arches was suddenly and irrevocably determined by the builder of the Ducal Palace, who, as we have seen, taking his first idea from the traceries of the Frari, and arranging those traceries as best fitted his own purpose, designed the great arcade (the lowest of the three in Plate XVII.), which thenceforward became the established model for every work of importance in Venice. The palaces built on this model, however, most of them not till the beginning of the fifteenth century, belong properly to the time of the Renaissance; and what little we have to note respecting them may be more clearly stated in connexion with other facts characteristic of that period.

§ XLIV. As the examples in Plate XVII. are necessarily confined to the upper parts of the windows, I have given in the Plate opposite (XVIII.*) examples of the fifth order window,

* This Plate is not from a drawing of mine. It has been engraved by Mr. Armytage, with great skill, from two daguerreotypes.

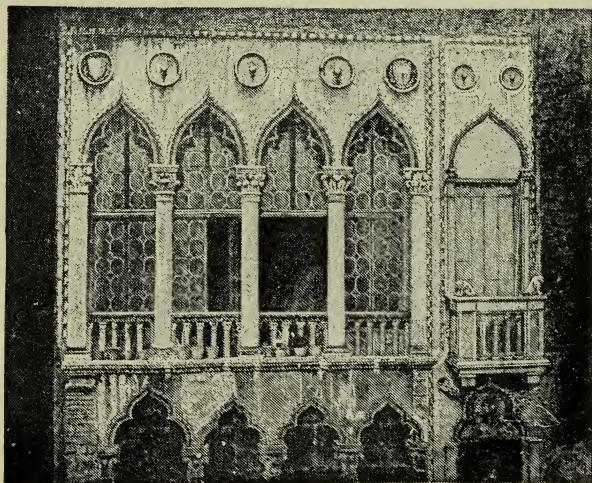
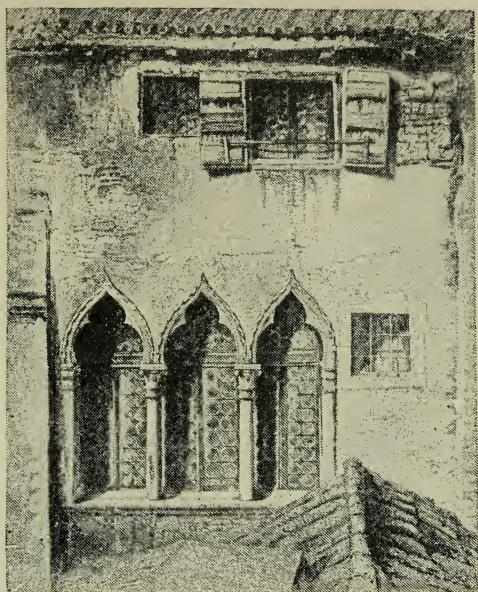

PLATE XVIII.—WINDOWS OF THE FIFTH ORDER.

both in its earliest and in its fully developed form, completed from base to keystone. The upper example is a beautiful group from a small house, never of any size or pretension, and now inhabited only by the poor, in the Campiello della Strope, close to the Church of San Giacomo de Lorio. It is remarkable for its excessive purity of curve, and is of very early date, its mouldings being simpler than usual.† The lower example is from the second story of a palace belonging to the Priuli family, near San Lorenzo, and shows one feature to which our attention has not hitherto been directed, namely, the penetration of the cusp, leaving only a silver thread of stone traced on the darkness of the window. I need not say that, in this condition, the cusp ceases to have any constructive use, and is merely decorative, but often exceedingly beautiful. The steps of transition from the early solid cusp to this slender thread are noticed in the final Appendix, under the head "Tracery Bars;" the commencement of the change being in the thinning of the stone, which is not cut through until it is thoroughly emaciated. Generally speaking, the condition in which the cusp is found is a useful test of age, when compared with other points; the more solid it is, the more ancient: but the massive form is often found associated with the perforated, as late as the beginning of the fourteenth century. In the Ducal Palace, the lower or bearing traceries have the solid cusp, and the upper traceries of the windows, which are merely decorative, have the perforated cusp, both with exquisite effect.

§ XLV. The smaller balconies between the great shafts in the lower example in Plate XVIII. are original and characteristic: not so the lateral one of the detached window, which has been restored; but by imagining it to be like that represented in fig. 1, Plate XIII., above, which is a perfect window of the finest time of the fifth order, the reader will be unable to form a complete idea of the external appearance of the principal apartments in the house of a noble of Venice, at the beginning of the fourteenth century.

§ XLVI. Whether noble, or merchant, or, as frequently hap-

* Vide final Appendix, under head "Archivolt."

pened, both, every Venetian appears, at this time, to have raised his palace or dwelling-house upon one type. Under every condition of importance, through every variation of size, the forms and mode of decoration of all the features were universally alike; not servilely alike, but fraternally; not with the sameness of coins cast from one mould, but with the likeness of the members of one family. No fragment of the period is preserved, in which the windows, be they few or many, a group of three or an arcade of thirty, have not the noble cusped arch of the fifth order. And they are especially to be noted by us at this day, because these refined and richly ornamented forms were used in the habitations of a nation as laborious, as practical, as brave, and as prudent as ourselves; and they were built at a time when that nation was struggling with calamities and changes threatening its existence almost every hour. And, farther, they are interesting because perfectly applicable to modern habitation. The refinement of domestic life appears to have been far advanced in Venice from her earliest days; and the remains of her Gothic palaces are, at this day, the most delightful residences in the city, having undergone no change in external form, and probably having been rather injured than rendered more convenient by the modifications which poverty and Renaissance taste, contending with the ravages of time, have introduced in the interiors. So that, in Venice, and the cities grouped around it, Vicenza, Padua, and Verona, the traveller may ascertain, by actual experience, the effect which would be produced upon the comfort or luxury of daily life by the revival of the Gothic school of architecture. He can still stand upon the marble balcony in the soft summer air, and feel its smooth surface warm from the noontide as he leans on it in the twilight; he can still see the strong sweep of the unruined traceries drawn on the deep serenity of the starry sky, and watch the fantastic shadows of the clustered arches shorten in the moonlight on the chequered floor; or he may close the casements fitted to their unshaken shafts against such wintry winds as would have made an English house vibrate to its foundation, and, in either case, compare their influence on his

daily home feeling with that of the square openings in his English wall.

§ XLVII. And let him be assured, if he find there is more to be enjoyed in the Gothic window, there is also more to be trusted. It is the best and strongest building, as it is the most beautiful. I am not now speaking of the particular form of Venetian Gothic, but of the general strength of the pointed arch as opposed to that of the level lintel of the square window; and I plead for the introduction of the Gothic form into our domestic architecture, not merely because it is lovely, but because it is the only form of faithful, strong, enduring, and honorable building, in such materials as come daily to our hands. By increase of scale and cost, it is possible to build, in any style, what will last for ages; but only in the Gothic is it possible to give security and dignity to work wrought with imperfect means and materials. And I trust that there will come a time when the English people may see the folly of building basely and insecurely. It is common with those architects against whose practice my writings have hitherto been directed, to call them merely theoretical and imaginative. I answer, that there is not a single principle asserted either in the "Seven Lamps" or here, but is of the simplest, sternest veracity, and the easiest practicability; that buildings, raised as I would have them, would stand unshaken for a thousand years; and the buildings raised by the architects who oppose them will not stand for one hundred and fifty, they sometimes do not stand for an hour. There is hardly a week passes without some catastrophe brought about by the base principles of modern buildings; some vaultless floor that drops the staggering crowd through the jagged rents of its rotten timbers; some baseless bridge that is washed away by the first wave of a summer flood; some fungous wall of nascent rottenness that a thunder-shower soaks down with its workmen into a heap of slime and death.* These we hear of, day by day: yet these indi-

* "On Thursday, the 20th, the front walls of two of the new houses now building in Victoria Street, Westminster, fell to the ground. . . . The roof was on, and a massive *compo cornice* was put up at top, as well

cate but the thousandth part of the evil. The portion of the national income sacrificed in mere bad building, in the perpetual repairs, and swift condemnation and pulling down of ill-built shells of houses, passes all calculation. And the weight of the penalty is not yet felt; it will tell upon our children some fifty years hence, when the cheap work, and contract work, and stucco and plaster work, and bad iron work, and all the other expedients of modern rivalry, vanity, and dishonesty, begin to show themselves for what they are.

§ XLVIII. Indeed, dishonesty and false economy will no more build safely in Gothic than in any other style: but of all forms which we could possibly employ, to be framed hastily and out of bad materials, the common square window is the worst; and its level head of brickwork (*a*, Fig. XXXV.) is the weakest way of covering a space. Indeed, in the hastily heaped shells of modern houses, there may be seen often even a worse manner of placing the bricks, as at *b*, supporting them by a bit of lath till the mortar dries; but even when worked with the

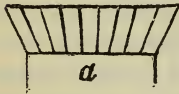

FIG. XXXV.

utmost care, and having every brick tapered into the form of a voussoir and accurately fitted, I have seen such a window-head give way, and a wide fissure torn through all the brickwork above it, two years after it was built; while the pointed arch of the Veronese Gothic, wrought in brick also, occurs at every corner of the streets of the city, untouched since the thirteenth century, and without a single flaw.

§ XLIX. Neither can the objection, so often raised against the pointed arch, that it will not admit the convenient adjustment of modern sashes and glass, hold for an instant. There is not the smallest necessity, because the arch is pointed, that

as dressings to the upper windows. The roof is formed by girders and $4\frac{1}{2}$ -brick arches in cement, covered with asphalt to form a flat. The failure is attributed to the quantity of rain which has fallen. Others suppose that some of the girders were defective, and gave way, carrying the walls with them.—*Builder*, for January 29th, 1853. The rest of this volume might be filled with such notices, if we sought for them.

the aperture should be so. The work of the arch is to sustain the building above ; when this is once done securely, the pointed head of it may be filled in any way we choose. In the best cathedral doors it is always filled by a shield of solid stone ; in many early windows of the best Gothic it is filled in the same manner, the introduced slab of stone becoming a field for rich decoration ; and there is not the smallest reason why lancet windows, used in bold groups, with each pointed arch filled by a sculptured tympanum, should not allow as much light to enter, and in as convenient a way, as the most luxuriously glazed square windows of our brick houses. Give the groups of associated lights bold gabled canopies ; charge the gables with sculpture and color ; and instead of the base and almost useless Greek portico, letting the rain and wind enter it at will, build the steeply vaulted and completely sheltered Gothic porch ; and on all these fields for rich decoration let the common workman carve what he pleases, to the best of his power, and we may have a school of domestic architecture in the nineteenth century, which will make our children grateful to us, and proud of us, till the thirtieth.

§ L. There remains only one important feature to be examined, the entrance gate or door. We have already observed that the one seems to pass into the other, a sign of increased love of privacy rather than of increased humility, as the Gothic palaces assume their perfect form. In the Byzantine palaces the entrances appear always to have been rather great gates than doors, magnificent semicircular arches opening to the water, and surrounded by rich sculpture in the archivolt. One of these entrances is seen in the small wood-cut above, Fig. XXV., and another has been given carefully in my folio work : their sculpture is generally of grotesque animals scattered among leafage, without any definite meaning ; but the great outer entrance of St. Mark's, which appears to have been completed some time after the rest of the fabric, differs from all others in presenting a series of subjects altogether Gothic in feeling, selection, and vitality of execution, and which show the occult entrance of the Gothic spirit before it had yet succeeded in effecting any modification of the Byzantine forms.

These sculptures represent the months of the year employed in the avocations usually attributed to them throughout the whole compass of the middle ages, in Northern architecture and manuscript calendars, and at last exquisitely versified by Spenser. For the sake of the traveller in Venice, who should examine this archivolt carefully, I shall enumerate these sculptures in their order, noting such parallel representations as I remember in other work.

§ LI. There are four successive archivolts, one within the other, forming the great central entrance of St. Mark's. The first is a magnificent external arch, formed of obscure figures mingled among masses of leafage, as in ordinary Byzantine work; within this there is a hemispherical dome, covered with modern mosaic; and at the back of this recess the other three archivolts follow consecutively, two sculptured, one plain; the one with which we are concerned is the outermost.

It is carved both on its front and under-surface or soffit; on the front are seventeen female figures bearing scrolls, from which the legends are unfortunately effaced. These figures were once gilded on a dark blue ground, as may still be seen in Gentile Bellini's picture of St. Mark's in the Accademia delle Belle Arti. The sculptures of the months are on the under surface, beginning at the bottom on the left hand of the spectator as he enters, and following in succession round the archivolt; separated, however, into two groups, at its centre, by a beautiful figure of the youthful Christ, sitting in the midst of a slightly hollowed sphere covered with stars to represent the firmament, and with the attendant sun and moon, set one on each side to rule over the day and over the night.

§ LII. The months are personified as follows:—

1. JANUARY. *Carrying home a noble tree on his shoulders, the leafage of which nods forwards, and falls nearly to his feet. Superbly cut. This is a rare representation of him. More frequently he is represented as the two-headed Janus, sitting at a table, drinking at one mouth and eating at the other. Sometimes as an old man, warming his feet at a fire, and drinking from a bowl; though this type is generally reserved*

for February. Spenser, however, gives the same symbol as that on St. Mark's :

“Numbd with holding all the day
An hatchet keene, with which he felled wood.”

His sign, Aquarius, is obscurely indicated in the archivolt by some wavy lines representing water, unless the figure has been broken away.

2. FEBRUARY. *Sitting in a carved chair, warming his bare feet at a blazing fire.* Generally, when he is thus represented, there is a pot hung over the fire, from the top of the chimney. Sometimes he is pruning trees, as in Spenser :

“ Yet had he by his side
His plough and harness fit to till the ground,
And tooles to prune the trees.”

Not unfrequently, in the calendars, this month is represented by a female figure carrying candles, in honor of the Purification of the Virgin.

His sign, Pisces, is prominently carved above him.

3. MARCH. Here, as almost always in Italy, *a warrior* : the Mars of the Latins being of course, in mediæval work, made representative of the military power of the place and period ; and thus, at Venice, having the winged Lion painted upon his shield. In Northern work, however, I think March is commonly employed in pruning trees ; or, at least, he is so when that occupation is left free for him by February's being engaged with the ceremonies of Candlemas. Sometimes, also, he is reaping a low and scattered kind of grain ; and by Spenser, who exactly marks the junction of mediæval and classical feeling, his military and agricultural functions are united, while also, in the Latin manner, he is made the first of the months.

“ First sturdy March, with brows full sternly bent,
And arm'd strongly, rode upon a Ram,
The same which over Hellespontus swam ;
Yet in his hand a spade he also hent,
And in a bag all sorts of seeds ysame,*
Which on the earth he strowed as he went.”

* “ Ysame,” collected together.

His sign, the Ram, is very superbly carved above him in the archivolt.

4. APRIL. Here, *carrying a sheep upon his shoulder*. A rare representation of him. In Northern work he is almost universally gathering flowers, or holding them triumphantly in each hand. The Spenserian mingling of this mediæval image with that of his being wet with showers, and wanton with love, by turning his zodiacal sign, Taurus, into the bull of Europa, is altogether exquisite.

“Upon a Bull he rode, the same which led
 Europa floating through the Argolick fluds:
 His horns were gilden all with golden studs,
 And garnishèd with garlonds goodly dight
 Of all the fairest flowres and freshest buds
 Which th’ earth brings forth; and *wet he seemed in sight*
With waves, through which he waded for his love’s delight.”

5. MAY is seated, while two young maidens crown him with flowers. A very unusual representation, even in Italy; where, as in the North, he is almost always riding out hunting or hawking, sometimes playing on a musical instrument. In Spenser, this month is personified as “the fayrest mayd on ground,” borne on the shoulders of the Twins.

In this archivolt there are only two heads to represent the zodiacal sign.

The summer and autumnal months are always represented in a series of agricultural occupations, which, of course, vary with the locality in which they occur; but generally in their order only. Thus, if June is mowing, July is reaping; if July is mowing, August is reaping; and so on. I shall give a parallel view of some of these varieties presently; but, meantime, we had better follow the St. Mark’s series, as it is peculiar in some respects.

6. JUNE. *Reaping*. The corn and sickle sculptured with singular care and precision, in bold relief, and the zodiacal sign, the Crab, above, also worked with great spirit. Spenser puts plough irons into his hand. Sometimes he is sheep-shearing; and, in English and northern French manuscripts,

carrying a kind of fagot or barrel, of the meaning of which I am not certain.

7. JULY. *Mowing.* A very interesting piece of sculpture, owing to the care with which the flowers are wrought out among the long grass. I do not remember ever finding July but either reaping or mowing. Spenser works him hard, and puts him to both labors :

“Behinde his backe a sithe, and by his side
Under his belt he bore a sickle circling wide.”

8. AUGUST. Peculiarly represented in this archivolt, *sitting in a chair, with his head upon his hand, as if asleep; the Virgin (the zodiacal sign) above him, lifting up her hand.* This appears to be a peculiarly Italian version of the proper employment of August. In Northern countries he is generally threshing, or gathering grapes. Spenser merely clothes him with gold, and makes him lead forth

“the righteous Virgin, which of old
Lived here on earth, and plenty made abound.”

9. SEPTEMBER. *Bearing home grapes in a basket.* Almost always sowing, in Northern work. By Spenser, with his usual exquisite ingenuity, employed in gathering in the general harvest, and *portioning it out with the Scales,* his zodiacal sign.

10. OCTOBER. *Wearing a conical hat, and digging busily with a long spade.* In Northern work he is sometimes a vintager, sometimes beating the acorns out of an oak to feed swine. When September is vintaging, October is generally sowing. Spenser employs him in the harvest both of vine and olive.

11. NOVEMBER. *Seems to be catching small birds in a net.* I do not remember him so employed elsewhere. He is nearly always killing pigs; sometimes beating the oak for them; with Spenser, fattening them.

12. DECEMBER. *Killing swine.* It is hardly ever that this employment is not given to one or other of the terminal

months of the year. If not so engaged, December is usually putting new loaves into the oven; sometimes killing oxen. Spenser properly makes him feasting and drinking instead of January.

§ LIII. On the next page I have given a parallel view of the employment of the months from some Northern manuscripts, in order that they may be more conveniently compared with the sculptures of St. Mark's, in their expression of the varieties of climate and agricultural system. Observe that the letter (f.) in some of the columns, opposite the month of May, means that he has a falcon on his fist; being, in those cases, represented as riding out, in high exultation, on a caparisoned white horse. A series nearly similar to that of St. Mark's occurs on the door of the Cathedral of Lucca, and on that of the Baptistery of Pisa; in which, however, if I recollect rightly, February is fishing, and May has something resembling an umbrella in his hand, instead of a hawk. But, in all cases, the figures are treated with the peculiar spirit of the Gothic sculptors; and this archivolt is the first expression of that spirit which is to be found in Venice.

§ LIV. In the private palaces, the entrances soon admitted some concession to the Gothic form also. They pass through nearly the same conditions of change as the windows, with these three differences: first, that no arches of the fantastic fourth order occur in any doorways; secondly, that the pure pointed arch occurs earlier, and much oftener, in doorways than in window-heads; lastly, that the entrance itself, if small, is nearly always square-headed in the earliest examples, without any arch above, but afterwards the arch is thrown across above the lintel. The interval between the two, or tympanum, is filled with sculpture, or closed by iron bars, with sometimes a projecting gable, to form a porch, thrown over the whole, as in the perfect example, 7 *a*, Plate XIV., above. The other examples in the two lower lines, 6 and 7, of that Plate are each characteristic of an enormous number of doors, variously decorated, from the thirteenth to the close of the fifteenth century. The particulars of their mouldings are given in the final Appendix.

	ST. MARK'S.	<i>MS. French.</i> Late Thirteenth Century.	<i>MS. French.</i> Late Thirteenth Century.	<i>MS. French.</i> Late Thirteenth Century.	<i>MS. French.</i> Early Fourteenth Century.	<i>MS. English.</i> Early Fourteenth Century.	<i>MS. Flemish.</i> Fifteenth Century.
JANUARY.....	Carrying wood.	Janus feasting.	Janus feasting.	Drinking and stir- ring fire.	Warming feet.	Janus feasting.	Feasting.
FEBRUARY....	Warming feet.	Warming feet.	Warming feet.	Pruning.	Bearing candles.	Warming feet.	Warming hands.
MARCH.....	Going to war.	Pruning.	Pruning.	Striking with axe.	Pruning.	Carrying candles.	Reaping.
APRIL.....	Carrying sheep.	Gathering flowers.	Gathering flowers.	Gathering flowers.	Gathering flowers.	Pruning.	Gathering flowers.
MAY.....	Crowned with flowers.	Riding (f.).	Riding (f.).	Playing on violin.	Riding (f.).	Riding (f.).	Riding with lady on pillion.
JUNE.....	Reaping.	Mowing.	Mowing.	Gathering largered flowers.	Carrying (fagots?)	Carrying fagots.	Sheep-shearing.
JULY.....	Mowing.	Reaping.	Reaping.	Mowing.	Mowing.	Mowing.	Mowing.
AUGUST.....	Asleep.	Threshing.	Gathering grapes.	Reaping.	Reaping.	Reaping.	Reaping.
SEPTEMBER...	Carrying grapes.	Sowing.	Sowing.	Drinking wine.	Threshing.	Threshing.	Sowing.
OCTOBER.....	Digging.	Gathering grapes.	Beating oak.	Sowing.	Sowing.	Sowing.	Beating oak.
NOVEMBER....	Catching birds.	Beating oak.	Killing swine.	Killing swine.	Killing swine.	Killing swine.	Pressing (grapes?)
DECEMBER....	Killing swine.	Killing swine.	Baking.	Killing oxen.	Baking.	Baking.	Killing swine.

§ LV. It was useless, on the small scale of this Plate, to attempt any delineation of the richer sculptures with which the arches are filled ; so that I have chosen for it the simplest examples I could find of the forms to be illustrated : but, in all the more important instances, the door-head is charged either with delicate ornaments and inlaid patterns in variously colored brick, or with sculptures, consisting always of the shield or crest of the family, protected by an angel. Of these more perfect doorways I have given three examples carefully, in my folio work ; but I must repeat here one part of the account of their subjects given in its text, for the convenience of those to whom the larger work may not be accessible.

§ LVI. “ In the earlier ages, all agree thus far, that the name of the family is told, and together with it there is always an intimation that they have placed their defence and their prosperity in God’s hands ; frequently accompanied with some general expression of benediction to the person passing over the threshold. This is the general theory of an old Venetian doorway ;—the theory of modern doorways remains to be explained : it may be studied to advantage in our rows of new-built houses, or rather of new-built house, changeless for miles together, from which, to each inhabitant, we allot his proper quantity of windows, and a Doric portico. The Venetian carried out his theory very simply. In the centre of the archivolt we find almost invariably, in the older work, the hand between the sun and moon in the attitude of blessing, expressing the general power and presence of God, the source of light. On the tympanum is the shield of the family. Venetian heraldry requires no beasts for supporters, but usually prefers angels, neither the supporters nor crests forming any necessary part of Venetian bearings. Sometimes, however, human figures, or grotesques, are substituted ; but, in that case, an angel is almost always introduced above the shield, bearing a globe in his left hand, and therefore clearly intended for the ‘ Angel of the Lord,’ or, as it is expressed elsewhere, the ‘ Angel of His Presence.’ Where elaborate sculpture of this kind is inadmissible, the shield is merely represented as suspended by a leather thong ; and a cross is introduced above

the archivolt. The Renaissance architects perceived the irrationality of all this, cut away both crosses and angels, and substituted heads of satyrs, which were the proper presiding deities of Venice in the Renaissance periods, and which in our own domestic institutions, we have ever since, with much piety and sagacity, retained."

§ LVII. The habit of employing some religious symbol, or writing some religious legend, over the door of the house, does not entirely disappear until far into the period of the Renaissance. The words "Peace be to this house" occur on one side of a Veronese gateway, with the appropriate and veracious inscription S.P.Q.R., on a Roman standard, on the other; and "Blessed is he that cometh in the name of the Lord," is written on one of the doorways of a building added at the flank of the Casa Barbarigo, in the sixteenth or seventeenth century. It seems to be only modern Protestantism which is entirely ashamed of *all* symbols and words that appear in anywise like a confession of faith.

§ LVIII. This peculiar feeling is well worthy of attentive analysis. It indeed, in most cases, hardly deserves the name of a feeling; for the meaningless doorway is merely an ignorant copy of heathen models: but yet, if it were at this moment proposed to any of us, by our architects, to remove the grinning head of a satyr, or other classical or Palladian ornament, from the keystone of the door, and to substitute for it a cross, and an inscription testifying our faith, I believe that most persons would shrink from the proposal with an obscure and yet overwhelming sense that things would be sometimes done, and thought, within the house which would make the inscription on its gate a base hypocrisy. And if so, let us look to it, whether that strong reluctance to utter a definite religious profession, which so many of us feel, and which, not very carefully examining into its dim nature, we conclude to be modesty, or fear of hypocrisy, or other such form of amiableness, be not, in very deed, neither less nor more than Infidelity; whether Peter's "I know not the man" be not the sum and substance of all these misgivings and hesitations; and whether the shamefacedness which we attribute

to sincerity and reverence, be not such shamefacedness as may at last put us among those of whom the Son of Man shall be ashamed.

§ LIX. Such are the principal circumstances to be noted in the external form and details of the Gothic palaces; of their interior arrangements there is little left unaltered. The gateways which we have been examining almost universally lead, in the earlier palaces, into a long interior court, round which the mass of the palace is built; and in which its first story is reached by a superb external staircase, sustained on four or five pointed arches gradually increasing as they ascend, both in height and span,—this change in their size being, so far as I remember, peculiar to Venice, and visibly a consequence of the habitual admission of arches of different sizes in the Byzantine façades. These staircases are protected by exquisitely carved parapets, like those of the outer balconies, with lions or grotesque heads set on the angles, and with true projecting balconies on their landing-places. In the centre of the court there is always a marble well; and these wells furnish some of the most superb examples of Venetian sculpture. I am aware only of one remaining from the Byzantine period; it is octagonal, and treated like the richest of our Norman fonts: but the Gothic wells of every date, from the thirteenth century downwards, are innumerable, and full of beauty, though their form is little varied; they being, in almost every case, treated like colossal capitals of pillars, with foliage at the angles, and the shield of the family upon their sides.

§ LX. The interior apartments always consist of one noble hall on the first story, often on the second also, extending across the entire depth of the house, and lighted in front by the principal groups of its windows, while smaller apartments open from it on either side. The ceilings, where they remain untouched, are of bold horizontal beams, richly carved and gilded; but few of these are left from the true Gothic times, the Venetian interiors having, in almost every case, been remodelled by the Renaissance architects. This change, however, for once, we cannot regret, as the walls and ceilings, when so altered, were covered with the noblest works of

Veronese, Titian, and Tintoret ; nor the interior walls only, but, as before noticed, often the exteriors also. Of the color decorations of the Gothic exteriors I have, therefore, at present taken no notice, as it will be more convenient to embrace this subject in one general view of the systems of coloring of the Venetian palaces, when we arrive at the period of its richest development.* The details, also, of most interest, respecting the forms and transitional decoration of their capitals, will be given in the final Appendix to the next volume, where we shall be able to include in our inquiry the whole extent of the Gothic period ; and it remains for us, therefore, at present, only to review the history, fix the date, and note the most important particulars in the structure of the building which at once consummates and embodies the entire system of the Gothic architecture of Venice,—the DUCAL PALACE.

CHAPTER VIII.

THE DUCAL PALACE.

§ 1. It was stated in the commencement of the preceding chapter that the Gothic art of Venice was separated by the building of the Ducal Palace into two distinct periods ; and that in all the domestic edifices which were raised for half a century after its completion, their characteristic and chiefly effective portions were more or less directly copied from it. The fact is, that the Ducal Palace was the great work of Venice at this period, itself the principal effort of her imagination, employing her best architects in its masonry, and her best painters in its decoration, for a long series of years ; and we must receive it as a remarkable testimony to the influence which it possessed over the minds of those who saw it in its progress, that, while in the other cities of Italy every palace and church was rising in some original and daily more

* Vol. III. Chap. I. I have had considerable difficulty in the arrangement of these volumes, so as to get the points bearing upon each other grouped in consecutive and intelligible order.

daring form, the majesty of this single building was able to give pause to the Gothic imagination in its full career ; stayed the restlessness of innovation in an instant, and forbade the powers which had created it thenceforth to exert themselves in new directions, or endeavor to summon an image more attractive.

§ II. The reader will hardly believe that while the architectural invention of the Venetians was thus lost, Narcissus-like, in self-contemplation, the various accounts of the progress of the building thus admired and beloved are so confused as frequently to leave it doubtful to what portion of the palace they refer ; and that there is actually, at the time being, a dispute between the best Venetian antiquaries, whether the main façade of the palace be of the fourteenth or fifteenth century. The determination of this question is of course necessary before we proceed to draw any conclusions from the style of the work ; and it cannot be determined without a careful review of the entire history of the palace, and of all the documents relating to it. I trust that this review may not be found tedious,—assuredly it will not be fruitless,—bringing many facts before us, singularly illustrative of the Venetian character.

§ III. Before, however, the reader can enter upon any inquiry into the history of this building, it is necessary that he should be thoroughly familiar with the arrangement and names of its principal parts, as it at present stands ; otherwise he cannot comprehend so much as a single sentence of any of the documents referring to it. I must do what I can, by the help of a rough plan and bird's-eye view, to give him the necessary topographical knowledge :

Fig. XXXVI. opposite is a rude ground plan of the buildings round St. Mark's Place ; and the following references will clearly explain their relative positions :

- A. St. Mark's Place.
- B. Piazzetta.
- P. V. Procuratie Vecchie.
- P. N. (opposite) Procuratie Nuove.
- P. L. Libreria Vecchia.

- I. Piazzetta de' Leoni.
 T. Tower of St. Mark.
 F F. Great Façade of St. Mark's Church.
 M. St. Mark's. (It is so united with the Ducal Palace, that the separation cannot be indicated in the plan, unless all the walls had been marked, which would have confused the whole.)
 D D D. Ducal Palace. g s. Giant's stair.
 C. Court of Ducal Palace. J. Judgment angle.
 c. Porta della Carta a. Fig-tree angle.
 p p. Ponte della Paglia (Bridge of Straw).
 S. Ponte de' Sospiri (Bridge of Sighs).
 R R. Riva de' Schiavoni.

The reader will observe that the Ducal Palace is arranged somewhat in the form of a hollow square, of which one side faces the Piazzetta, B, and another the quay called the Riva de' Schiavoni, R R; the third is on the dark canal called the "Rio del Palazzo," and the fourth joins the Church of St. Mark.

Of this fourth side, therefore, nothing can be seen. Of the other three sides we shall have to speak constantly; and they will be respectively called, that towards the Piazzetta, the "Piazzetta Façade;" that towards the Riva de' Schiavoni, the "Sea Façade;" and that towards the Rio del Palazzo, the "Rio Façade." This Rio, or canal, is usually looked upon by the traveller with great respect, or even horror, because it passes under the Bridge of Sighs. It is, however, one of the principal thoroughfares of the city; and the bridge and its canal together occupy, in the mind of a Venetian, very much the position of Fleet Street and Temple Bar in that of a Londoner,—at least, at the time when Temple Bar was occasionally decorated with human heads. The two buildings closely resemble each other in form.

§ IV. We must now proceed to obtain some rough idea of the appearance and distribution of the palace itself; but its arrangement will be better understood by supposing ourselves raised some hundred and fifty feet above the point in the lagoon in front of it, so as to get a general view of the Sea Façade and Rio Façade (the latter in very steep perspective), and to look down into its interior court. Fig. XXXVII. roughly represents such a view, omitting all details on the roofs, in order

to avoid confusion. In this drawing we have merely to notice that, of the two bridges seen on the right, the uppermost, above the black canal, is the Bridge of Sighs; the lower one is the Ponte della Paglia, the regular thoroughfare from quay to quay, and, I believe, called the Bridge of Straw, because the boats which brought straw from the mainland used to sell it at this place. The corner of the palace, rising above this bridge, and formed by the meeting of the Sea Façade and Rio Façade, will always be called the Vine angle, because it is decorated by a sculpture of the drunkenness of Noah. The angle opposite will be called the Fig-tree angle, because it is decorated by a sculpture of the Fall of Man. The long and narrow range of building, of which the roof is seen in perspective behind this angle, is the part of the palace fronting the Piazzetta; and the angle under the pinnacle most to the left of the two which terminate it will be called, for a reason presently to be stated, the Judgment angle. Within the square formed by the building is seen its interior court (with one of its wells), terminated by small and fantastic buildings of the Renaissance period, which face the Giant's Stair, of which the extremity is seen sloping down on the left.

§ v. The great façade which fronts the spectator looks southward. Hence the two traceried windows lower than the rest, and to the right of the spectator, may be conveniently distinguished as the "Eastern Windows." There are two others like them, filled with tracery, and at the same level, which look upon the narrow canal between the Ponte della Paglia and the Bridge of Sighs: these we may conveniently call the "Canal Windows." The reader will observe a vertical line in this dark side of the palace, separating its nearer and plainer wall from a long four-storied range of rich architecture. This more distant range is entirely Renaissance: its extremity is not indicated, because I have no accurate sketch of the small buildings and bridges beyond it, and we shall have nothing whatever to do with this part of the palace in our present inquiry. The nearer and undecorated wall is part of the older palace, though much defaced by modern opening of common windows, refittings of the brickwork, &c.

§ VI. It will be observed that the façade is composed of a smooth mass of wall, sustained on two tiers of pillars, one above the other. The manner in which these support the whole fabric will be understood at once by the rough section, fig. XXXVIII., which is supposed to be taken right through the palace to the interior court, from near the middle of the Sea Façade. Here *a* and *d* are the rows of shafts, both in the inner court and on the Façade, which carry the main walls; *b*, *c* are solid walls variously strengthened with pilasters. A, B, C are the three stories of the interior of the palace.

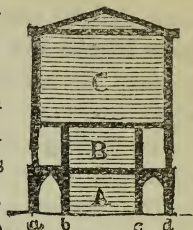

FIG. XXXVIII.

The reader sees that it is impossible for any plan to be more simple, and that if the inner floors and walls of the stories A, B were removed, there would be left merely the form of a basilica,—two high walls, carried on ranges of shafts, and roofed by a low gable.

The stories A, B are entirely modernized, and divided into confused ranges of small apartments, among which what vestiges remain of ancient masonry are entirely undecipherable, except by investigations such as I have had neither the time nor, as in most cases they would involve the removal of modern plastering, the opportunity, to make. With the subdivisions of this story, therefore, I shall not trouble the reader; but those of the great upper story, C, are highly important.

§ VII. In the bird's-eye view above, fig. XXXVII., it will be noticed that the two windows on the right are lower than the other four of the façade. In this arrangement there is one of the most remarkable instances I know of the daring sacrifice of symmetry to convenience, which was noticed in Chap. VII. as one of the chief noblenesses of the Gothic schools.

The part of the palace in which the two lower windows occur, we shall find, was first built, and arranged in four stories in order to obtain the necessary number of apartments. Owing to circumstances, of which we shall presently give an account, it became necessary, in the beginning of the fourteenth century, to provide another large and magnificent chamber for

the meeting of the senate. That chamber was added at the side of the older building ; but, as only one room was wanted, there was no need to divide the added portion into two stories. The entire height was given to the single chamber, being indeed not too great for just harmony with its enormous length and breadth. And then came the question how to place the windows, whether on a line with the two others, or above them.

The ceiling of the new room was to be adorned by the paintings of the best masters in Venice, and it became of great importance to raise the light near that gorgeous roof, as well as to keep the tone of illumination in the Council Chamber serene ; and therefore to introduce light rather in simple masses than in many broken streams. A modern architect, terrified at the idea of violating external symmetry, would have sacrificed both the pictures and the peace of the council. He would have placed the larger windows at the same level with the other two, and have introduced above them smaller windows, like those of the upper story in the older building, as if that upper story had been continued along the façade. But the old Venetian thought of the honor of the paintings, and the comfort of the senate, before his own reputation. He unhesitatingly raised the large windows to their proper position with reference to the interior of the chamber, and suffered the external appearance to take care of itself. And I believe the whole pile rather gains than loses in effect by the variation thus obtained in the spaces of wall above and below the windows.

§ VIII. On the party wall, between the second and third windows, which faces the eastern extremity of the Great Council Chamber, is painted the Paradise of Tintoret ; and this wall will therefore be hereafter called the "Wall of the Paradise."

In nearly the centre of the Sea Façade, and between the first and second windows of the Great Council Chamber, is a large window to the ground, opening on a balcony, which is one of the chief ornaments of the palace, and will be called in future the "Sea Balcony."

The façade which looks on the Piazzetta is very nearly like this to the Sea, but the greater part of it was built in the fifteenth century, when people had become studious of their symmetries. Its side windows are all on the same level. Two light the west end of the Great Council Chamber, one lights a small room anciently called the Quarantia Civil Nuova; the other three, and the central one, with a balcony like that to the Sea, light another large chamber, called Sala del Scrutinio, or "Hall of Enquiry," which extends to the extremity of the palace above the Porta della Carta.

§ ix. The reader is now well enough acquainted with the topography of the existing building, to be able to follow the accounts of its history.

We have seen above, that there were three principal styles of Venetian architecture; Byzantine, Gothic, and Renaissance.

The Ducal Palace, which was the great work of Venice, was built successively in the three styles. There was a Byzantine Ducal Palace, a Gothic Ducal Palace, and a Renaissance Ducal Palace. The second superseded the first totally; a few stones of it (if indeed so much) are all that is left. But the third superseded the second in part only, and the existing building is formed by the union of the two.

We shall review the history of each in succession.*

1st. THE BYZANTINE PALACE.

In the year of the death of Charlemagne, 813,† the Vene-

* The reader will find it convenient to note the following editions of the printed books which have been principally consulted in the following inquiry. The numbers of the manuscripts referred to in the Marcian Library are given with the quotations.

Sansovino. *Venetia Descritta*. 4to, Venice, 1663.

Sansovino. *Lettera intorno al Palazzo Ducale*. 8vo, Venice, 1829.

Temanza. *Antica Pianta di Venezia*, with text. Venice, 1780.

Cadorin. *Pareri di XV. Architetti*. 8vo, Venice, 1838.

Filiasi. *Memorie storiche*. 8vo, Padua, 1811.

Bettio. *Lettera discorsiva del Palazzo Ducale*. 8vo, Venice, 1837.

Selvatico. *Architettura di Venezia*. 8vo, Venice, 1847.

† The year commonly given is 810, as in the Savina Chronicle (Cod. Marcianus), p. 13. "Del 810 fece principiar el pallazzo Ducal nel luogo

tians determined to make the island of Rialto the seat of the government and capital of their state. Their Doge, Angelo or Agnello Participazio, instantly took vigorous means for the enlargement of the small group of buildings which were to be the nucleus of the future Venice. He appointed persons to superintend the raising of the banks of sand, so as to form more secure foundations, and to build wooden bridges over the canals. For the offices of religion, he built the Church of St. Mark; and on, or near, the spot where the Ducal Palace now stands, he built a palace for the administration of the government.*

The history of the Ducal Palace therefore begins with the birth of Venice, and to what remains of it, at this day, is entrusted the last representation of her power.

§ x. Of the exact position and form of this palace of Participazio little is ascertained. Sansovino says that it was "built near the Ponte della Paglia, and answeringly on the Grand Canal," † towards San Giorgio; that is to say, in the place now occupied by the Sea Façade; but this was merely

ditto Bruolo in confin di S. Moisè, et fece riedificar la isola di Eraclia." The Sagornin Chronicle gives 804; and Filiasi, vol. vi. chap. 1, corrects this date to 813.

* "Ampliò la città, fornilla di casamenti, e per il culto d' Iddio e l' amministrazione della giustizia eresse la cappella di S. Marco, e il palazzo di sua residenza."—Pareri, p. 120. Observe, that piety towards God, and justice towards man, have been at least the nominal purposes of every act and institution of ancient Venice. Compare also Temanza, p. 24. "Quello che abbiamo di certo si è che il suddetto Agnello lo incominciò da fondamenti, e cost pure la cappella ducale di S. Marco."

† What I call the Sea, was called "the Grand Canal" by the Venetians, as well as the great water street of the city; but I prefer calling it "the Sea," in order to distinguish between that street and the broad water in front of the Ducal Palace, which, interrupted only by the island of San Giorgio, stretches for many miles to the south, and for more than two to the boundary of the Lido. It was the deeper channel, just in front of the Ducal Palace, continuing the line of the great water street itself which the Venetians spoke of as "the Grand Canal." The words of Sansovino are: "Fu cominciato dove si vede, vicino al ponte della paglia, et rispondente sul canal grande." Filiasi says simply: "The palace was built where it now is." "Il palazzo fu fatto dove ora

the popular report of his day. We know, however, positively, that it was somewhere upon the site of the existing palace ; and that it had an important front towards the Piazzetta, with which, as we shall see hereafter, the present palace at one period was incorporated. We know, also, that it was a pile of some magnificence, from the account given by Sagornino of the visit paid by the Emperor Otho the Great, to the Doge Pietro Orseolo II. The chronicler says that the Emperor "beheld carefully all the beauty of the palace ;"* and the Venetian historians express pride in the building's being worthy of an emperor's examination. This was after the palace had been much injured by fire in the revolt against Candiano IV.,† and just repaired, and richly adorned by Orseolo himself, who is spoken of by Sagornino as having also "adorned the chapel of the Ducal Palace" (St. Mark's) with ornaments of marble and gold.‡ There can be no doubt whatever that the palace at this period resembled and impressed the other Byzantine edifices of the city, such as the

pure esiste."—Vol. iii. chap. 27. The Savina Chronicle, already quoted, says: "In the place called the Bruolo (or Broglio), that is to say, on the Piazzetta."

* "Omni decoritate illius perlustrata."—Sagornino, quoted by Cadorin and Temanza.

† There is an interesting account of this revolt in Monaci, p. 68. Some historians speak of the palace as having been destroyed entirely ; but, that it did not even need important restorations, appears from Sagornino's expression, quoted by Cadorin and Temanza. Speaking of the Doge Participazio, he says: "Qui Palatii hucusque manentis fuerit fabricator." The repairs of the palace are usually attributed to the successor of Candiano, Pietro Orseolo I. ; but the legend, under the picture of that Doge in the Council Chamber, speaks only of his rebuilding St. Mark's, and "performing many miracles." His whole mind seems to have been occupied with ecclesiastical affairs ; and his piety was finally manifested in a way somewhat startling to the state, by his absconding with a French priest to St. Michael's, in Gascony, and there becoming a monk. What repairs, therefore, were necessary to the Ducal Palace, were left to be undertaken by his son, Orseolo II., above named.

‡ "Quam non modo marmoreo, verum aureo compsit ornamento."—*Temanza*, p. 25.

Fondaco de Turchi, &c., whose remains have been already described; and that, like them, it was covered with sculpture, and richly adorned with gold and color.

§ XI. In the year 1106, it was for the second time injured by fire,* but repaired before 1116, when it received another emperor, Henry V. (of Germany), and was again honored by imperial praise.† Between 1173 and the close of the century, it seems to have been again repaired and much enlarged by the Doge Sebastian Ziani. Sansovino says that this Doge not only repaired it, but “enlarged it in every direction;”‡ and, after this enlargement, the palace seems to have remained untouched for a hundred years, until, in the commencement of the fourteenth century, the works of the Gothic Palace were begun. As, therefore, the old Byzantine building was, at the time when those works first interfered with it, in the form given to it by Ziani, I shall hereafter always speak of it as the *Ziani Palace*; and this the rather, because the only chronicler whose words are perfectly clear respecting the existence of part of this palace so late as the year 1422, speaks of it as built by Ziani. The old “palace, of which half remains to this day, was built, as we now see it, by Sebastian Ziani.” §

So far, then, of the Byzantine Palace.

§ XII. 2nd. THE GOTHIC PALACE. The reader, doubtless, recollects that the important change in the Venetian government which gave stability to the aristocratic power took place

* “L’anno 1106, uscito fuoco d’una casa privata, arse parte del palazzo.”—*Sansovino*. Of the beneficial effect of these fires, vide Cadorin, p. 121, 123.

† “Urbis situm, ædificiorum decorem, et regiminis æquitatem multipliciter commendavit.”—*Cronaca Dandolo*, quoted by Cadorin.

‡ “Non solamente rinovò il palazzo, ma lo aggrandì per ogni verso.”—*Sansovino*. Zanotto quotes the Altinat Chronicle for account of these repairs.

§ “El palazzo che anco di mezzo se vede vecchio, per M. Sebastian Ziani fu fatto compir, come el se vede.”—*Chronicle of Pietro Dolfino*, Cod. Ven. p. 47. This Chronicle is spoken of by Sansovino as “molto particolare e distinta.”—*Sansovino, Venezia descritta*, p. 593.—It terminates in the year 1422.

about the year 1297,* under the Doge Pietro Gradenigo, a man thus characterized by Sansovino :—"A prompt and prudent man, of unconquerable determination and great eloquence, who laid, so to speak, the foundations of the eternity of this republic, by the admirable regulations which he introduced into the government."

We may now, with some reason, doubt of their admirableness ; but their importance, and the vigorous will and intellect of the Doge, are not to be disputed. Venice was in the zenith of her strength, and the heroism of her citizens was displaying itself in every quarter of the world.† The acquiescence in the secure establishment of the aristocratic power was an expression, by the people, of respect for the families which had been chiefly instrumental in raising the commonwealth to such a height of prosperity.

The Serrar del Consiglio fixed the numbers of the Senate within certain limits, and it conferred upon them a dignity greater than they had ever before possessed. It was natural that the alteration in the character of the assembly should be attended by some change in the size, arrangement, or decoration of the chamber in which they sat.

We accordingly find it recorded by Sansovino, that "in 1301 another saloon was begun on the Rio del Palazzo, *under the Doge Gradenigo*, and finished in 1309, *in which year the Grand Council first sat in it.*" ‡ In the first year, therefore, of the fourteenth century, the Gothic Ducal Palace of Venice was begun ; and as the Byzantine Palace was, in its foundation, coeval with that of the state, so the Gothic Palace was, in its foundation, coeval with that of the aristocratic power. Considered as the principal representation of the Venetian school of architecture, the Ducal Palace is the Parthenon of Venice, and Gradenigo its Pericles.

§ XIII. Sansovino, with a caution very frequent among Venetian historians, when alluding to events connected with the Serrar del Consiglio, does not specially mention the cause for

* See Vol. I. Appendix 3.

† Vide Sansovino's enumeration of those who flourished in the reign of Gradenigo, p. 564.

‡ Sansovino, 324, 1.

the requirement of the new chamber ; but the Sivos Chronicle is a little more distinct in expression. "In 1301, it was determined to build a great saloon *for the assembling* of the Great Council, and the room was built which is *now* called the Sala del Scrutinio."* *Now*, that is to say, at the time when the Sivos Chronicle was written ; the room has long ago been destroyed, and its name given to another chamber on the opposite side of the palace : but I wish the reader to remember the date 1301, as marking the commencement of a great architectural epoch, in which took place the first appliance of the energy of the aristocratic power, and of the Gothic style, to the works of the Ducal Palace. The operations then begun were continued, with hardly an interruption, during the whole period of the prosperity of Venice. We shall see the new buildings consume, and take the place of, the Ziani Palace, piece by piece : and when the Ziani Palace was destroyed, they fed upon themselves ; being continued round the square, until, in the sixteenth century, they reached the point where they had been begun in the fourteenth, and pursued the track they had then followed some distance beyond the junction ; destroying or hiding their own commencement, as the serpent, which is the type of eternity, conceals its tail in its jaws.

§ XIV. We cannot, therefore, *see* the extremity, wherein lay the sting and force of the whole creature,—the chamber, namely, built by the Doge Gradenigo ; but the reader must keep that commencement and the date of it carefully in his mind. The body of the Palace Serpent will soon become visible to us.

The Gradenigo Chamber was somewhere on the Rio Façade,

* "1301 fu presa parte di fare una sala grande per la riduzione del gran consiglio, e fu fatta quella che ora si chiama dello Scrutinio."—*Uronaca Sivos*, quoted by Cadorin. There is another most interesting entry in the Chronicle of Magno, relating to this event ; but the passage is so ill written, that I am not sure if I have deciphered it correctly :— "Del 1301 fu preso de fabricar la sala fo ruina e fu fata (fatta) quella se adoperava a far el pregadi e fu adopera per far el Gran Consegio fin 1423, che fu anni 122." This last sentence, which is of great importance, is luckily unmistakable :—"The room was used for the meetings of the Great Council until 1423, that is to say, for 122 years."—*Cod. Ven.* tom. i. p. 126. The chronicle extends from 1253 to 1454.

behind the present position of the Bridge of Sighs; i.e. about the point marked on the roof by the dotted lines in the wood-cut; it is not known whether low or high, but probably on a first story. The great façade of the Ziani Palace being, as above mentioned, on the Piazzetta, this chamber was as far back and out of the way as possible; secrecy and security being obviously the points first considered.

§ xv. But the newly constituted Senate had need of other additions to the ancient palace besides the Council Chamber. A short, but most significant, sentence is added to Sansovino's account of the construction of that room. "There were, *near it*," he says, "the Cancellaria, and the *Gheba* or *Gabbia*, afterwards called the Little Tower."*

Gabbia means a "cage;" and there can be no question that certain apartments were at this time added at the top of the palace and on the Rio Façade, which were to be used as prisons. Whether any portion of the old Torresella still remains is a doubtful question; but the apartments at the top of the palace, in its fourth story, were still used for prisons as late as the beginning of the seventeenth century.† I wish the reader especially to notice that a separate tower or range of apartments was built for this purpose, in order to clear the government of the accusations so constantly made against them, by ignorant or partial historians, of wanton cruelty to prisoners. The stories commonly told respecting the "piombi" of the Ducal Palace are utterly false. Instead of being, as usually reported, small furnaces under the leads of the palace, they were comfortable rooms, with good flat roofs of larch, and carefully ventilated.‡ The new chamber, then,

* "Vi era appresso la Cancellaria, e la Gheba o Gabbia, chiamata poi Torresella."—P. 324. A small square tower is seen above the Vine angle in the view of Venice dated 1500, and attributed to Albert Durer. It appears about 25 feet square, and is very probably the Torresella in question.

† Vide Bettio, Lettera, p. 23.

‡ Bettio, Lettera, p. 20. "Those who wrote without having seen them described them as covered with lead; and those who have seen them know that, between their flat timber roofs and the sloping leaden roof of the palace, the interval is five metres where it is least, and nine where it is greatest."

and the prisons, being built, the Great Council first sat in their retired chamber on the Rio in the year 1309.

§ XVI. Now, observe the significant progress of events. They had no sooner thus established themselves in power than they were disturbed by the conspiracy of the Tiepolos, in the year 1310. In consequence of that conspiracy the Council of Ten was created, still under the Doge Gradenigo; who, having finished his work and left the aristocracy of Venice armed with this terrible power, died in the year 1312, some say by poison. He was succeeded by the Doge Marino Giorgio, who reigned only one year; and then followed the prosperous government of John Soranzo. There is no mention of any additions to the Ducal Palace during his reign, but he was succeeded by that Francesco Dandolo, the sculptures on whose tomb, still existing in the cloisters of the Salute, may be compared by any traveller with those of the Ducal Palace. Of him it is recorded in the Savina Chronicle: "This Doge also had the great gate built which is at the entry of the palace, above which is his statue kneeling, with the gonfalon in hand, before the feet of the Lion of St. Mark's."*

§ XVII. It appears, then, that after the Senate had completed their Council Chamber and the prisons, they required a nobler door than that of the old Ziani Palace for their Magnificences to enter by. This door is twice spoken of in the government accounts of expenses, which are fortunately preserved, † in the following terms:—

"1335, June 1. We, Andrew Dandolo and Mark Loredano, procurators of St. Mark's, have paid to Martin the stone-cutter and his associates ‡ . . . for a stone of which the lion is made which is put over the gate of the palace."

* "Questo Dose anche fese far la porta granda che se al intrar del Pallazzo, in su la qual vi e la sua statua che sta in zenocchioni con lo confalon in man, davanti li pie de lo Lion S. Marco."—*Savin Chronicle*, Cod. Ven. p. 120.

† These documents I have not examined myself, being satisfied of the accuracy of Cadorin, from whom I take the passages quoted.

‡ "Libras tres, soldos 15 grossorum."—*Cadorin*, 189, 1.

“1344, November 4. We have paid thirty-five golden ducats for making gold leaf, to gild the lion which is over the door of the palace stairs.”

The position of this door is disputed, and is of no consequence to the reader, the door itself having long ago disappeared, and been replaced by the Porta della Carta.

§ XVIII. But before it was finished, occasion had been discovered for farther improvements. The Senate found their new Council Chamber inconveniently small, and, about thirty years after its completion, began to consider where a larger and more magnificent one might be built. The government was now thoroughly established, and it was probably felt that there was some meanness in the retired position, as well as insufficiency in the size, of the Council Chamber on the Rio. The first definite account which I find of their proceedings, under these circumstances, is in the Caroldo Chronicle : *

“1340. On the 28th of December, in the preceding year, Master Marco Erizzo, Nicolo Soranzo, and Thomas Gradonigo, were chosen to examine where a new saloon might be built in order to assemble therein the Greater Council. . .

. . . On the 3rd of June, 1341, the Great Council elected two procurators of the work of this saloon, with a salary of eighty ducats a year.”

It appears from the entry still preserved in the Archivio, and quoted by Cadorin, that it was on the 28th of December, 1340, that the commissioners appointed to decide on this important matter gave in their report to the Grand Council, and that the decree passed thereupon for the commencement of a new Council Chamber on the Grand Canal. †

The room then begun is the one now in existence, and its building involved the building of all that is best and most beautiful in the present Ducal Palace, the rich arcades of the

* Cod. Ven., No. CXXI. p. 365.

† Sansovino is more explicit than usual in his reference to this decree : “For it having appeared that the place (the first Council Chamber) was not capacious enough, the saloon on the Grand Canal was ordered.” “Per cio parendo che il luogo non fosse capace, fu ordinata la Sala sul Canal Grande.”—P. 324.

lower stories being all prepared for sustaining this Sala del Gran Consiglio.

§ XIX. In saying that it is the same now in existence, I do not mean that it has undergone no alterations ; as we shall see hereafter, it has been refitted again and again, and some portions of its walls rebuilt ; but in the place and form in which it first stood, it still stands ; and by a glance at the position which its windows occupy, as shown in fig. XXXVII. above, the reader will see at once that whatever can be known respecting the design of the Sea Façade, must be gleaned out of the entries which refer to the building of this Great Council Chamber.

Cadorin quotes two of great importance, to which we shall return in due time, made during the progress of the work in 1342 and 1344 ; then one of 1349, resolving that the works at the Ducal Palace, which had been discontinued during the plague, should be resumed ; and finally one in 1362, which speaks of the Great Council Chamber as having been neglected and suffered to fall into “great desolation,” and resolves that it shall be forthwith completed.*

The interruption had not been caused by the plague only, but by the conspiracy of Faliero, and the violent death of the master builder.† The work was resumed in 1362, and completed within the next three years, at least so far as that Guariento was enabled to paint his Paradise on the walls ; ‡ so that the building must, at any rate, have been roofed by this time. Its decorations and fittings, however, were long in completion ; the paintings on the roof being only executed in 1400. § They represented the heavens covered with stars,||

* Cadorin, 185, 2. The decree of 1342 is falsely given as of 1345 by the Sivos Chronicle, and by Magno ; while Sanuto gives the decree to its right year, 1342, but speaks of the Council Chamber as only begun in 1345.

† Calendario. See Appendix 1, Vol. III.

‡ “ Il primo che vi colorisse fu Guariento, il quale l'anno 1365 vi fece il Paradiso in testa della sala.”—*Sansorino*.

§ “ L' an poi 1400 vi fece il cielo compartita a quadretti d' oro, ripieni di stelle, ch' era la insegna del Doge Steno.”—*Sansorino*, lib. VIII.

|| “ In questi tempi si messe in oro il cielo della sala del Gran Consig-

this being, says Sansovino, the bearings of the Doge Steno. Almost all ceilings and vaults were at this time in Venice covered with stars, without any reference to armorial bearings; but Steno claims, under his noble title of Stellifer, an important share in completing the chamber, in an inscription upon two square tablets, now inlaid in the walls on each side of the great window towards the sea :

“MILLE QUADRINGENTI CURREBANT QUATUOR ANNI

HOC OPUS ILLUSTRIS MICHAEL DUX STELLIFER AUXIT.”

And in fact it is to this Doge that we owe the beautiful balcony of that window, though the work above it is partly of more recent date ; and I think the tablets bearing this important inscription have been taken out and reinserted in the newer masonry. The labor of these final decorations occupied a total period of sixty years. The Grand Council sat in the finished chamber for the first time in 1423. In that year the Gothic Ducal Palace of Venice was completed. It had taken, to build it, the energies of the entire period which I have above described as the central one of her life.

§ XX. 3rd. The RENAISSANCE PALACE. I must go back a step or two, in order to be certain that the reader understands clearly the state of the palace in 1423. The works of addition or renovation had now been proceeding, at intervals, during a space of a hundred and twenty-three years. Three generations at least had been accustomed to witness the gradual advancement of the form of the Ducal Palace into more stately symmetry, and to contrast the works of sculpture and painting with which it was decorated,—full of the life, knowledge, and hope of the fourteenth century,—with the rude Byzantine chiselling of the palace of the Doge Ziani. The magnificent fabric just completed, of which the new Council Chamber was the nucleus, was now habitually known in Venice as the “Palazzo Nuovo;” and the old Byzantine

lio et si fece il pergolo del finestra grande chi guarda sul canale, adornato l' uno e l' altro di stelle, ch' erano l' insegne del Doge.”—*Sansovino*, lib. XIII. Compare also Pareri, p. 129.

edifice, now ruinous, and more manifest in its decay by its contrast with the goodly stones of the building which had been raised at its side, was of course known as the "Palazzo Vecchio." * That fabric, however, still occupied the principal position in Venice. The new Council Chamber had been erected by the side of it towards the Sea ; but there was not then the wide quay in front, the Riva dei Schiavoni, which now renders the Sea Façade as important as that to the Piazzetta. There was only a narrow walk between the pillars and the water ; and the *old* palace of Ziani still faced the Piazzetta, and interrupted, by its decrepitude, the magnificence of the square where the nobles daily met. Every increase of the beauty of the new palace rendered the discrepancy between it and the companion building more painful ; and then began to arise in the minds of all men a vague idea of the necessity of destroying the old palace, and completing the front of the Piazzetta with the same splendor as the Sea Façade. But no such sweeping measure of renovation had been contemplated by the Senate when they first formed the plan of their new Council Chamber. First a single additional room, then a gateway, then a larger room ; but all considered merely as necessary additions to the palace, not as involving the entire reconstruction of the ancient edifice. The exhaustion of the treasury, and the shadows upon the political horizon, rendered it more than imprudent to incur the vast additional expense which such a project involved ; and the Senate, fearful of itself, and desirous to guard against the weakness of its own enthusiasm, passed a decree, like the effort of a man fearful of some strong temptation to keep his thoughts averted from the point of danger. It was a decree, not merely that the old palace should not be rebuilt, but that no one should *propose* rebuilding it. The feeling of the desirableness of doing so was too strong to permit fair discussion, and the Senate knew that to bring forward such a motion was to carry it.

§ XXI. The decree, thus passed in order to guard against

* Baseggio (Pareri, p. 127) is called the Proto of the *New Palace*. Farther notes will be found in Appendix 1, Vol. III.

their own weakness, forbade any one to speak of rebuilding the old palace under the penalty of a thousand ducats. But they had rated their own enthusiasm too low: there was a man among them whom the loss of a thousand ducats could not deter from proposing what he believed to be for the good of the state.

Some excuse was given him for bringing forward the motion, by a fire which occurred in 1419, and which injured both the church of St. Mark's, and part of the old palace fronting the Piazzetta. What followed, I shall relate in the words of Sanuto.*

§ XXII. "Therefore they set themselves with all diligence and care to repair and adorn sumptuously, first God's house; but in the Prince's house things went on more slowly, *for it did not please the Doge* † *to restore it in the form in which it was before*; and they could not rebuild it altogether in a better manner, so great was the parsimony of these old fathers; because it was forbidden by laws, which condemned in a penalty of a thousand ducats any one who should propose to throw down the *old* palace, and to rebuild it more richly and with greater expense. But the Doge, who was magnanimous, and who desired above all things what was honorable to the city, had the thousand ducats carried into the Senate Chamber, and then proposed that the palace should be rebuilt; saying: that, 'since the late fire had ruined in great part the Ducal habitation (not only his own private palace, but all the places used for public business) this occasion was to be taken for an admonishment sent from God, that they ought to rebuild the palace more nobly, and in a way more befitting the greatness to which, by God's grace, their dominions had reached; and that his motive in proposing this was neither ambition, nor selfish interest: that, as for ambition, they might have seen in the whole course of his life, through so many years, that he had never done anything for ambition, either in the city, or in foreign business; but in all his actions had kept justice first in his thoughts, and then the advantage

* Cronaca Sanudo, No. cxxv. in the Marcian Library, p. 568.

† Tomaso Mocenigo.

of the state, and the honor of the Venetian name: and that, as far as regarded his private interest, if it had not been for this accident of the fire, he would never have thought of changing anything in the palace into either a more sumptuous or a more honorable form; and that during the many years in which he had lived in it, he had never endeavored to make any change, but had always been content with it, as his predecessors had left it; and that he knew well that, if they took in hand to build it as he exhorted and besought them, being now very old, and broken down with many toils, God would call him to another life before the walls were raised a pace from the ground. And that therefore they might perceive that he did not advise them to raise this building for his own convenience, but only for the honor of the city and its Dukedom: and that the good of it would never be felt by him, but by his successors.' Then he said, that 'in order, as he had always done, to observe the laws, . . . he had brought with him the thousand ducats which had been appointed as the penalty for proposing such a measure, so that he might prove openly to all men that it was not his own advantage that he sought, but the dignity of the state.' There was no one (Sanuto goes on to tell us) who ventured, or desired, to oppose the wishes of the Doge; and the thousand ducats were unanimously devoted to the expenses of the work. "And they set themselves with much diligence to the work; and the palace was begun in the form and manner in which it is at present seen; but, as Mocenigo had prophesied, not long after, he ended his life, and not only did not see the work brought to a close, but hardly even begun."

§ XXIII. There are one or two expressions in the above extracts which, if they stood alone, might lead the reader to suppose that the whole palace had been thrown down and rebuilt. We must however remember, that, at this time, the new Council Chamber, which had been one hundred years in building, was actually unfinished, the council had not yet sat in it; and it was just as likely that the Doge should then propose to destroy and rebuild it, as in this year, 1853, it is that any one should propose in our House of Commons to

throw down the new Houses of Parliament, under the title of the "old palace," and rebuild *them*.

§ xxiv. The manner in which Sanuto expresses himself will at once be seen to be perfectly natural, when it is remembered that although we now speak of the whole building as the "Ducal Palace," it consisted, in the minds of the old Venetians, of four distinct buildings. There were in it the palace, the state prisons, the senate-house, and the offices of public business; in other words, it was Buckingham Palace, the Tower of olden days, the Houses of Parliament, and Downing Street, all in one; and any of these four portions might be spoken of, without involving an allusion to any other. "Il Palazzo" was the Ducal residence, which, with most of the public offices, Mocenigo *did* propose to pull down and rebuild, and which was actually pulled down and rebuilt. But the new Council Chamber, of which the whole façade to the Sea consisted, never entered into either his or Sanuto's mind for an instant, as necessarily connected with the Ducal residence.

I said that the new Council Chamber, at the time when Mocenigo brought forward his measure, had never yet been used. It was in the year 1422 * that the decree passed to rebuild the palace: Mocenigo died in the following year, † and Francesco Foscari was elected in his room. The Great Council Chamber was used for the first time on the day when Foscari entered the Senate as Doge,—the 3rd of April, 1423, according to the Caroldo Chronicle; ‡ the 23rd, which is probably correct, by an anonymous MS., No. 60, in the Correr Museum; §—and, the following year, on the 27th of March,

* Vide notes in Appendix.

† On the 4th of April, 1423, according to the copy of the Zancarol Chronicle in the Marcian Library, but previously, according to the Caroldo Chronicle, which makes Foscari enter the Senate as Doge on the 3rd of April.

‡ "Nella quale (the Sala del Gran Consiglio) non si fece Gran Consiglio salvo nell' anno 1423, alli 3 April, et fu il primo giorno che il Duce Foscari venisse in Gran Consiglio dopo la sua creatione."—Copy in Marcian Library, p. 365.

§ "E a di 23 April (1423, by the context) sequente fo fatto Gran Con-

the first hammer was lifted up against the old palace of Ziani.*

§ xxv. That hammer stroke was the first act of the period properly called the "Renaissance." It was the knell of the architecture of Venice,—and of Venice herself.

The central epoch of her life was past; the decay had already begun: I dated its commencement above (Ch. I. Vol. I.) from the death of Mocenigo. A year had not yet elapsed since that great Doge had been called to his account: his patriotism, always sincere, had been in this instance mistaken; in his zeal for the honor of future Venice, he had forgotten what was due to the Venice of long ago. A thousand palaces might be built upon her burdened islands, but none of them could take the place, or recall the memory, of that which was first built upon her unfrequented shore. It fell; and, as if it had been the talisman of her fortunes, the city never flourished again.

§ xxvi. I have no intention of following out, in their intricate details, the operations which were begun under Foscari and continued under succeeding Doges till the palace assumed its present form, for I am not in this work concerned, except by occasional reference, with the architecture of the fifteenth century: but the main facts are the following. The palace of Ziani was destroyed: the existing façade to the Piazzetta built, so as both to continue and to resemble, in most particulars, the work of the Great Council Chamber. It was carried back from the Sea as far as the Judgment angle; beyond which is the Porta della Carta, begun in 1439, and finished in two years, under the Doge Foscari; † the interior buildings connected with it were added by the Doge Christopher Moro (the Othello of Shakspeare) ‡ in 1462.

seio in la salla nuovo dovi avanti non esta piu fatto Gran Consejo si che el primo Gran Consejo dopo la sua (Foscari's) creation, fo fatto in la salla nuova, nel qual conseio fu el Marchese di Mantoa," &c., p. 426.

* Compare Appendix 1, Vol. III.

† "Tutte queste fatture si compirono sotto il dogado del Foscari, nel 1441."—*Pareri*, p. 131.

‡ This identification has been accomplished, and I think conclusively, by my friend Mr. Rawdon Brown, who has devoted all the leisure which, during the last twenty years, his manifold offices of kindness to almost

§ xxvii. By reference to the figure the reader will see that we have now gone the round of the palace, and that the new work of 1462 was close upon the first piece of the Gothic palace, the *new* Council Chamber of 1301. Some remnants of the Ziani Palace were perhaps still left between the two extremities of the Gothic Palace ; or, as is more probable, the last stones of it may have been swept away after the fire of 1419, and replaced by new apartments for the Doge. But whatever buildings, old or new, stood on this spot at the time of the completion of the *Porta della Carta* were destroyed by another great fire in 1479, together with so much of the palace on the *Rio* that, though the saloon of *Gradenigo*, then known as the *Sala de' Pregadi*, was not destroyed, it became necessary to reconstruct the entire façades of the portion of the palace behind the *Bridge of Sighs*, both towards the court and canal. This work was entrusted to the best Renaissance architects of the close of the fifteenth and opening of the sixteenth centuries ; Antonio Ricci executing the *Giant's staircase*, and on his absconding with a large sum of the public money, Pietro Lombardo taking his place. The whole work must have been completed towards the middle of the sixteenth century. The architects of the palace, advancing round the square and led by fire, had more than reached the point from which they had set out ; and the work of 1560 was joined to the work of 1301—1340, at the point marked by the conspicuous vertical line in *Figure XXXVII.* on the *Rio Façade*.

§ xxviii. But the palace was not long permitted to remain in this finished form. Another terrific fire, commonly called the great fire, burst out in 1574, and destroyed the inner fittings and all the precious pictures of the *Great Council Chamber*, and of all the upper rooms on the *Sea Façade*, and most of those on the *Rio Façade*, leaving the building a mere shell, shaken and blasted by the flames. It was debated in the

every English visitant of Venice have left him, in discovering and translating the passages of the Venetian records which bear upon English history and literature. I shall have occasion to take advantage hereafter of a portion of his labors, which I trust will shortly be made public.

Great Council whether the ruin should not be thrown down, and an entirely new palace built in its stead. The opinions of all the leading architects of Venice were taken, respecting the safety of the walls, or the possibility of repairing them as they stood. These opinions, given in writing, have been preserved, and published by the Abbé Cadorin, in the work already so often referred to; and they form one of the most important series of documents connected with the Ducal Palace.

I cannot help feeling some childish pleasure in the accidental resemblance to my own name in that of the architect whose opinion was first given in favor of the ancient fabric, Giovanni Rusconi. Others, especially Palladio, wanted to pull down the old palace, and execute designs of their own; but the best architects in Venice, and to his immortal honor, chiefly Francesco Sansovino, energetically pleaded for the Gothic pile, and prevailed. It was successfully repaired, and Tintoret painted his noblest picture on the wall from which the Paradise of Guariento had withered before the flames.

§ xxix. The repairs necessarily undertaken at this time were however extensive, and interfere in many directions with the earlier work of the palace: still the only serious alteration in its form was the transposition of the prisons, formerly at the top of the palace, to the other side of the Rio del Palazzo; and the building of the Bridge of Sighs, to connect them with the palace, by Antonio da Ponte. The completion of this work brought the whole edifice into its present form; with the exception of alterations in doors, partitions, and staircases among the inner apartments, not worth noticing, and such barbarisms and defacements as have been suffered within the last fifty years, by, I suppose, nearly every building of importance in Italy.

§ xxx. Now, therefore, we are at liberty to examine some of the details of the Ducal Palace, without any doubt about their dates. I shall not, however, give any elaborate illustrations of them here, because I could not do them justice on the scale of the page of this volume, or by means of line engraving. I believe a new era is opening to us in the art of illustra-

tion,* and that I shall be able to give large figures of the details of the Ducal Palace at a price which will enable every person who is interested in the subject to possess them ; so that the cost and labor of multiplying illustrations here would be altogether wasted. I shall therefore direct the reader's attention only to such points of interest as can be explained in the text.

§ xxxi. First, then, looking back to the woodcut at the beginning of this chapter, the reader will observe that, as the building was very nearly square on the ground plan, a peculiar prominence and importance were given to its angles, which rendered it necessary that they should be enriched and softened by sculpture. I do not suppose that the fitness of this arrangement will be questioned ; but if the reader will take the pains to glance over any series of engravings of church towers or other four-square buildings in which great refinement of form has been attained, he will at once observe how their effect depends on some modification of the sharpness of the angle, either by groups of buttresses, or by turrets and niches rich in sculpture. It is to be noted also that this principle of breaking the angle is peculiarly Gothic, arising partly out of the necessity of strengthening the flanks of enormous buildings, where composed of imperfect materials, by buttresses or pinnacles ; partly out of the conditions of Gothic warfare, which generally required a tower at the angle ; partly out of the natural dislike of the meagreness of effect in buildings which admitted large surfaces of wall, if the angle were entirely unrelieved. The Ducal Palace, in its acknowledgment of this principle, makes a more definite concession to the Gothic spirit than any of the previous architecture of Venice. No angle, up to the time of its erection, had been otherwise decorated than by a narrow fluted pilaster of red marble, and the sculpture was reserved always, as in Greek and Roman work, for the plane surfaces of the building, with, as far as I recollect, two exceptions only, both in St. Mark's ; namely, the bold and grotesque gargoyle on its north-west angle, and the

* See the last chapter of the third volume.

angels which project from the four inner angles under the main cupola ; both of these arrangements being plainly made under Lombardic influence. And if any other instances occur, which I may have at present forgotten, I am very sure the Northern influence will always be distinctly traceable in them.

§ xxxii. The Ducal Palace, however, accepts the principle in its completeness, and throws the main decoration upon its angles. The central window, which looks rich and important in the woodcut, was entirely restored in the Renaissance time, as we have seen, under the Doge Steno ; so that we have no traces of its early treatment ; and the principal interest of the older palace is concentrated in the angle sculpture, which is arranged in the following manner. The pillars of the two bearing arcades are much enlarged in thickness at the angles, and their capitals increased in depth, breadth, and fulness of subject ; above each capital, on the angle of the wall, a sculptural subject is introduced, consisting, in the great lower arcade, of two or more figures of the size of life ; in the upper arcade, of a single angel holding a scroll : above these angels rise the twisted pillars with their crowning niches, already noticed in the account of parapets in the seventh chapter ; thus forming an unbroken line of decoration from the ground to the top of the angle.

§ xxxiii. It was before noticed that one of the corners of the palace joins the irregular outer buildings connected with St. Mark's, and is not generally seen. There remain, therefore, to be decorated, only the three angles, above distinguished as the Vine angle, the Fig-tree angle, and the Judgment angle ; and at these we have, according to the arrangement just explained,—

First, Three great bearing capitals (lower arcade).

Secondly, Three figure subjects of sculpture above them (lower arcade).

Thirdly, Three smaller bearing capitals (upper arcade).

Fourthly, Three angels above them (upper arcade).

Fifthly, Three spiral shafts with niches.

§ xxxiv. I shall describe the bearing capitals hereafter, in

their order, with the others of the arcade ; for the first point to which the reader's attention ought to be directed is the choice of subject in the great figure sculptures above them. These, observe, are the very corner stones of the edifice, and in them we may expect to find the most important evidences of the feeling, as well as of the skill, of the builder. If he has anything to say to us of the purpose with which he built the palace, it is sure to be said here ; if there was any lesson which he wished principally to teach to those for whom he built, here it is sure to be inculcated ; if there was any sentiment which they themselves desired to have expressed in the principal edifice of their city, this is the place in which we may be secure of finding it legibly inscribed.

§ xxxv. Now the first two angles, of the Vine and Fig-tree, belong to the old, or true Gothic, Palace ; the third angle belongs to the Renaissance imitation of it : therefore, at the first two angles, it is the Gothic spirit which is going to speak to us ; and, at the third, the Renaissance spirit.

The reader remembers, I trust, that the most characteristic sentiment of all that we traced in the working of the Gothic heart, was the frank confession of its own weakness ; and I must anticipate, for a moment, the results of our inquiry in subsequent chapters, so far as to state that the principal element in the Renaissance spirit, is its firm confidence in its own wisdom.

Hear, then, the two spirits speak for themselves.

The first main sculpture of the Gothic Palace is on what I have called the angle of the Fig-tree :

Its subject is the FALL OF MAN.

The second sculpture is on the angle of the Vine :

Its subject is the DRUNKENNESS OF NOAH.

The Renaissance sculpture is on the Judgment angle :

Its subject is the JUDGMENT OF SOLOMON.

It is impossible to overstate, or to regard with too much admiration, the significance of this single fact. It is as if the palace had been built at various epochs, and preserved uninjured to this day, for the sole purpose of teaching us the difference in the temper of the two schools.

§ xxxvi. I have called the sculpture on the Fig-tree angle the principal one; because it is at the central bend of the palace, where it turns to the Piazzetta (the façade upon the Piazzetta being, as we saw above, the more important one in ancient times). The great capital, which sustains this Fig-tree angle, is also by far more elaborate than the head of the pilaster under the Vine angle, marking the preëminence of the former in the architect's mind. It is impossible to say which was first executed, but that of the Fig-tree angle is somewhat rougher in execution, and more stiff in the design of the figures, so that I rather suppose it to have been the earliest completed.

§ xxxvii. In both the subjects, of the Fall and the Drunkenness, the tree, which forms the chiefly decorative portion of the sculpture,—fig in the one case, vine in the other,—was a necessary adjunct. Its trunk, in both sculptures, forms the true outer angle of the palace; boldly cut separate from the stonework behind, and branching out above the figures so as to enwrap each side of the angle, for several feet, with its deep foliage. Nothing can be more masterly or superb than the sweep of this foliage on the Fig-tree angle; the broad leaves lapping round the budding fruit, and sheltering from sight, beneath their shadows, birds of the most graceful form and delicate plumage. The branches are, however, so strong, and the masses of stone hewn into leafage so large, that, notwithstanding the depth of the undercutting, the work remains nearly uninjured; not so at the Vine angle, where the natural delicacy of the vine-leaf and tendril having tempted the sculptor to greater effort, he has passed the proper limits of his art, and cut the upper stems so delicately that half of them have been broken away by the casualties to which the situation of the sculpture necessarily exposes it. What remains is, however, so interesting in its extreme refinement, that I have chosen it for the subject of the opposite illustration rather than the nobler masses of the fig-tree, which ought to be rendered on a larger scale. Although half of the beauty of the composition is destroyed by the breaking away of its central masses, there is still enough in the distribution of the

variously bending leaves, and in the placing of the birds on the lighter branches, to prove to us the power of the designer. I have already referred to this Plate as a remarkable instance of the Gothic Naturalism ; and, indeed, it is almost impossible for the copying of nature to be carried farther than in the fibres of the marble branches, and the careful finishing of the tendrils : note especially the peculiar expression of the knotty joints of the vine in the light branch which rises highest. Yet only half the finish of the work can be seen in the Plate : for, in several cases, the sculptor has shown the under sides of the leaves turned boldly to the light, and has literally *carved every rib and vein upon them, in relief* ; not merely the main ribs which sustain the lobes of the leaf, and actually project in nature, but the irregular and sinuous veins which chequer the membranous tissue between them, and which the sculptor has represented conventionally as relieved like the others, in order to give the vine leaf its peculiar tessellated effect upon the eye.

§ xxxviii. As must always be the case in early sculpture, the figures are much inferior to the leafage ; yet so skilful in many respects, that it was a long time before I could persuade myself that they had indeed been wrought in the first half of the fourteenth century. Fortunately, the date is inscribed upon a monument in the Church of San Simeon Grande, bearing a recumbent statue of the saint, of far finer workmanship, in every respect, than those figures of the Ducal Palace, yet so like them, that I think there can be no question that the head of Noah was wrought by the sculptor of the palace in emulation of that of the statue of St. Simeon. In this latter sculpture, the face is represented in death ; the mouth partly open, the lips thin and sharp, the teeth carefully sculptured beneath ; the face full of quietness and majesty, though very ghastly ; the hair and beard flowing in luxuriant wreaths, disposed with the most masterly freedom, yet severity, of design, far down upon the shoulders ; the hands crossed upon the body, carefully studied, and the veins and sinews perfectly and easily expressed, yet without any attempt at extreme finish or display of technical skill. This monument

bears date 1317,* and its sculptor was justly proud of it; thus recording his name :

“CELAVIT MARCUS OPUS HOC INSIGNE ROMANIS,
LAUDIBUS NON PARCUS EST SUA DIGNA MANUS.”

§ XXXIX. The head of the Noah on the Ducal Palace, evidently worked in emulation of this statue, has the same profusion of flowing hair and beard, but wrought in smaller and harder curls ; and the veins on the arms and breast are more sharply drawn, the sculptor being evidently more practised in keen and fine lines of vegetation than in those of the figure ; so that, which is most remarkable in a workman of this early period, he has failed in telling his story plainly, regret and wonder being so equally marked on the features of all the three brothers that it is impossible to say which is intended for Ham. Two of the heads of the brothers are seen in the Plate ; the third figure is not with the rest of the group, but set at a distance of about twelve feet, on the other side of the arch which springs from the angle capital.

§ XL. It may be observed, as a farther evidence of the date of the group, that, in the figures of all the three youths, the feet are protected simply by a bandage arranged in crossed folds round the ankle and lower part of the limb ; a feature of dress which will be found in nearly every piece of figure sculpture in Venice, from the year 1300 to 1380, and of which the traveller may see an example within three hundred yards of this very group, in the bas-reliefs on the tomb of the Doge Andrea Dandolo (in St. Mark's), who died in 1354.

§ XLI. The figures of Adam and Eve, sculptured on each side of the Fig-tree angle, are more stiff than those of Noah and his sons, but are better fitted for their architectural service ; and the trunk of the tree, with the angular body of the serpent writhed around it, is more nobly treated as a terminal group of lines than that of the vine.

* “ IN XRI—NOIE AMEN ANNINCARNATIONIS MCCCXVII. INESETBR.”
“ In the name of Christ, Amen, in the year of the incarnation, 1317, in the month of September,” &c.

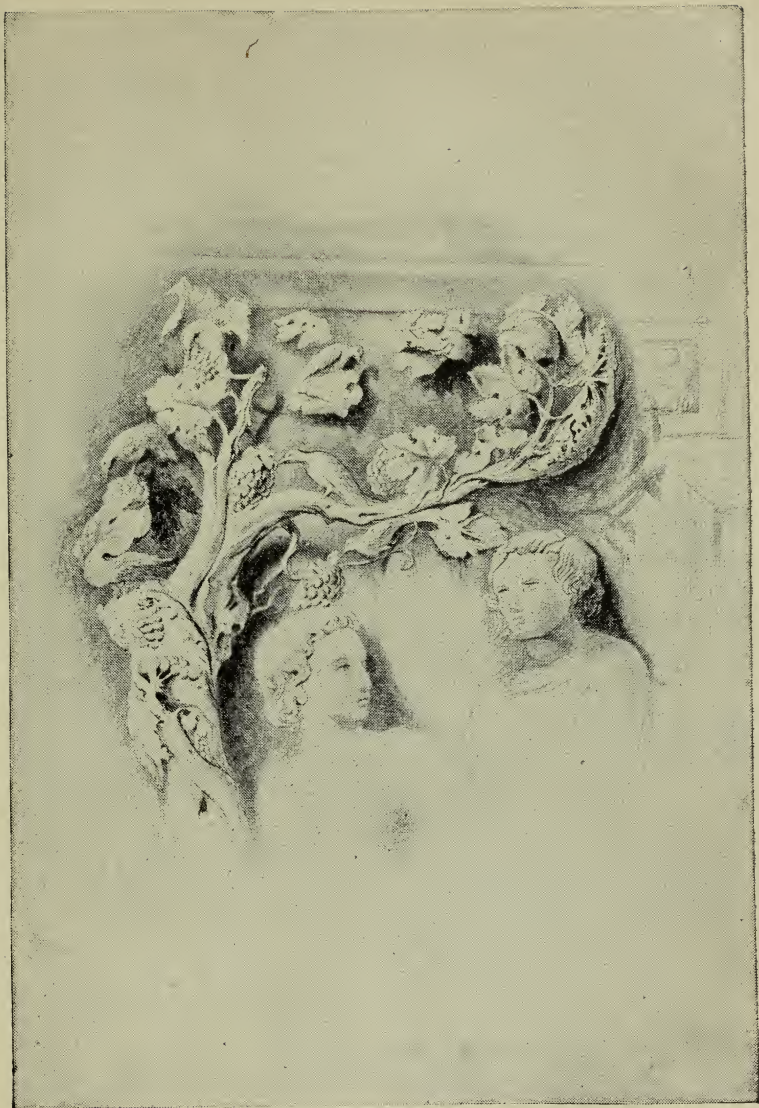

PLATE XIX.—LEAFAGE OF THE VINE ANGLE.

The Renaissance sculptor of the figures of the Judgment of Solomon has very nearly copied the fig-tree from this angle, placing its trunk between the executioner and the mother, who leans forward to stay his hand. But, though the whole group is much more free in design than those of the earlier palace, and in many ways excellent in itself, so that it always strikes the eye of a careless observer more than the others, it is of immeasurably inferior spirit in the workmanship; the leaves of the tree, though far more studiously varied in flow than those of the fig-tree from which they are partially copied, have none of its truth to nature; they are ill set on the stems, bluntly defined on the edges, and their curves are not those of growing leaves, but of wrinkled drapery.

§ XLII. Above these three sculptures are set, in the upper arcade, the statues of the archangels Raphael, Michael, and Gabriel: their positions will be understood by reference to the lowest figure in Plate XVII., where that of Raphael above the Vine angle is seen on the right. A diminutive figure of Tobit follows at his feet, and he bears in his hand a scroll with this inscription:

EFICE Q̄
SOFRE
TŪR AFA
EL REVE
RENDE
QUIETŪ

i.e. Effice (quæso?) fretum, Raphael reverende, quietum.* I could not decipher the inscription on the scroll borne by the angel Michael; and the figure of Gabriel, which is by much the most beautiful feature of the Renaissance portion of the palace, has only in its hand the Annunciation lily.

* "Oh, venerable Raphael, make thou the gulf calm, we beseech thee." The peculiar office of the angel Raphael is, in general, according to tradition, the restraining the harmful influences of evil spirits. Sir Charles Eastlake told me, that sometimes in this office he is represented bearing the gall of the fish caught by Tobit; and reminded me of the peculiar superstitions of the Venetians respecting the raising of storms by fiends, as embodied in the well-known tale of the Fisherman and St. Mark's ring.

§ XLIII. Such are the subjects of the main sculptures decorating the angles of the palace; notable, observe, for their simple expression of two feelings, the consciousness of human frailty, and the dependence upon Divine guidance and protection; this being, of course, the general purpose of the introduction of the figures of the angels; and, I imagine, intended to be more particularly conveyed by the manner in which the small figure of Tobit follows the steps of Raphael, just touching the hem of his garment. We have next to examine the course of divinity and of natural history embodied by the old sculpture in the great series of capitals which support the lower arcade of the palace; and which, being at a height of little more than eight feet above the eye, might be read, like the pages of a book, by those (the noblest men in Venice) who habitually walked beneath the shadow of this great arcade at the time of their first meeting each other for morning converse.

§ XLIV. The principal sculptures of the capitals consist of personifications of the Virtues and Vices, the favorite subjects of decorative art, at this period, in all the cities of Italy; and there is so much that is significant in the various modes of their distinction and general representation, more especially with reference to their occurrence as expressions of praise to the dead in sepulchral architecture, hereafter to be examined, that I believe the reader may both happily and profitably rest for a little while beneath the first vault of the arcade, to review the manner in which these symbols of the virtues were first invented by the Christian imagination, and the evidence they generally furnish of the state of religious feeling in those by whom they were recognized.

§ XLV. In the early ages of Christianity, there was little care taken to analyze character. One momentous question was heard over the whole world,—Dost thou believe in the Lord with all thine heart? There was but one division among men,—the great unatoneable division between the disciple and adversary. The love of Christ was all, and in all; and in proportion to the nearness of their memory of His person and teaching, men understood the infinity of the requirements of

the moral law, and the manner in which it alone could be fulfilled. The early Christians felt that virtue, like sin, was a subtle universal thing, entering into every act and thought, appearing outwardly in ten thousand diverse ways, diverse according to the separate framework of every heart in which it dwelt; but one and the same always in its proceeding from the love of God, as sin is one and the same in proceeding from hatred of God. And in their pure, early, and practical piety, they saw there was no need for codes of morality, or systems of metaphysics. Their virtue comprehended everything, entered into everything; it was too vast and too spiritual to be defined; but there was no need of its definition. For through faith, working by love, they knew that all human excellence would be developed in due order; but that, without faith, neither reason could define, nor effort reach, the lowest phase of Christian virtue. And therefore, when any of the Apostles have occasion to describe or enumerate any forms of vice or virtue by name, there is no attempt at system in their words. They use them hurriedly and energetically, heaping the thoughts one upon another, in order as far as possible to fill the reader's mind with a sense of the infinity both of crime and of righteousness. Hear St. Paul describe sin: "Being filled with all unrighteousness, fornication, wickedness, covetousness, maliciousness; full of envy, murder, debate, deceit, malignity; whisperers, backbiters, haters of God, despiteful, proud, boasters, inventors of evil things, disobedient to parents, without understanding, covenant breakers, without natural affection, implacable, unmerciful." There is evidently here an intense feeling of the universality of sin; and in order to express it, the Apostle hurries his words confusedly together, little caring about their order, as knowing all the vices to be indissolubly connected one with another. It would be utterly vain to endeavor to arrange his expressions as if they had been intended for the ground of any system, or to give any philosophical definition of the vices.* So also hear

* In the original, the succession of words is evidently suggested partly by similarity of sound; and the sentence is made weighty by an alliter

him speaking of virtue: "Rejoice in the Lord. Let your moderation be known unto all men. Be careful for nothing, but in everything let your requests be made known unto God; and whatsoever things are honest, whatsoever things are just, whatsoever things are pure, whatsoever things are lovely, whatsoever things are of good report, if there be any virtue, and if there be any praise, think on these things." Observe, he gives up all attempt at definition; he leaves the definition to every man's heart, though he writes so as to mark the overflowing fulness of his own vision of virtue. And so it is in all writings of the Apostles; their manner of exhortation, and the kind of conduct they press, vary according to the persons they address, and the feeling of the moment at which they write, and never show any attempt at logical precision. And, although the words of their Master are not thus irregularly uttered, but are weighed like fine gold, yet, even in His teaching, there is no detailed or organized system of morality; but the command only of that faith and love which were to embrace the whole being of man: "On these two commandments hang all the law and the prophets." Here and there an incidental warning against this or that more dangerous form of vice or error, "Take heed and beware of covetousness," "Beware of the leaven of the Pharisees;" here and there a plain example of the meaning of Christian love, as in the parables of the Samaritan and the Prodigal, and His own perpetual example: these were the elements of Christ's constant teaching; for the Beatitudes, which are the only approximation to anything like a systematic statement, belong to different conditions and characters of individual men, not to abstract virtues. And all early Christians taught in the same manner. They never cared to expound the nature of this or that virtue; for they knew that the believer who had Christ, had all. Did he need fortitude? Christ was his rock: Equity? Christ was his righteousness: Holiness? Christ was his sanctification: Liberty? Christ was his redemption: ation which is quite lost in our translation; but the very allowance of influence to these minor considerations is a proof how little any metaphysical order or system was considered necessary in the statement.

Temperance? Christ was his ruler: Wisdom? Christ was his light: Truthfulness? Christ was the truth: Charity? Christ was love.

§ XLVI. Now, exactly in proportion as the Christian religion became less vital, and as the various corruptions which time and Satan brought into it were able to manifest themselves, the person and offices of Christ were less dwelt upon, and the virtues of Christians more. The Life of the Believer became in some degree separated from the Life of Christ; and his virtue, instead of being a stream flowing forth from the throne of God, and descending upon the earth, began to be regarded by him as a pyramid upon earth, which he had to build up, step by step, that from the top of it he might reach the Heavens. It was not possible to measure the waves of the water of life, but it was perfectly possible to measure the bricks of the Tower of Babel; and gradually, as the thoughts of men were withdrawn from their Redeemer, and fixed upon themselves, the virtues began to be squared, and counted, and classified, and put into separate heaps of firsts and seconds; some things being virtuous cardinally, and other things virtuous only north-north-west. It is very curious to put in close juxtaposition the words of the Apostles and of some of the writers of the fifteenth century touching sanctification. For instance, hear first St. Paul to the Thessalonians: "The very God of peace sanctify you wholly; and I pray God your whole spirit and soul and body be preserved blameless unto the coming of our Lord Jesus Christ. Faithful is he that calleth you, who also will do it." And then the following part of a prayer which I translate from a MS. of the fifteenth century: "May He (the Holy Spirit) govern the five Senses of my body; may He cause me to embrace the Seven Works of Mercy, and firmly to believe and observe the Twelve Articles of the Faith and the Ten Commandments of the Law, and defend me from the Seven Mortal Sins, even to the end."

§ XLVII. I do not mean that this quaint passage is generally characteristic of the devotion of the fifteenth century: the very prayer out of which it is taken is in other parts exceed-

ingly beautiful : * but the passage is strikingly illustrative of the tendency of the later Romish Church, more especially in its most corrupt condition, just before the Reformation, to throw all religion into forms and ciphers ; which tendency, as it affected Christian ethics, was confirmed by the Renaissance enthusiasm for the works of Aristotle and Cicero, from whom the code of the fifteenth century virtues was borrowed, and whose authority was then infinitely more revered by all the Doctors of the Church than that either of St. Paul or St. Peter.

* It occurs in a prayer for the influence of the Holy Spirit, " That He may keep my soul, and direct my way ; compose my bearing, and form my thoughts in holiness ; may He govern my body, and protect my mind ; strengthen me in action, approve my vows, and accomplish my desires ; cause me to lead an honest and honorable life, and give me good hope, charity and chastity, humility and patience : may He govern the Five Senses of my body," &c. The following prayer is also very characteristic of this period. It opens with a beautiful address to Christ upon the cross ; then proceeds thus : " Grant to us, O Lord, we beseech thee, this day and ever, the use of penitence, of abstinence, of humility, and chastity ; and grant to us light, judgment, understanding, and true knowledge, even to the end." One thing I note in comparing old prayers with modern ones, that however quaint, or however erring, they are always tenfold more condensed, comprehensive, and to their purpose, whatever that may be. There is no dilution in them, no vain or monotonous phraseology. They ask for what is desired plainly and earnestly, and never could be shortened by a syllable. The following series of ejaculations are deep in spirituality, and curiously to our present purpose in the philological quaintness of being built upon prepositions : —

" Domine Jesu Christe, sancta cruce tua apud me sis, ut me defendas.

Domine Jesu Christe, pro veneranda cruce tua post me sis, ut me gubernes.

Domine Jesu Christe, pro benedicta cruce tua intra me sis, ut me re-
ficias.

Domine Jesu Christe, pro benedicta cruce tua circa me sis, ut me con-
serves.

Domine Jesu Christe, pro gloriosa cruce tua ante me sis, ut me de-
duces.

Domine Jesu Christe, pro laudanda cruce tua super me sis, ut bene-
dicas.

Domine Jesu Christe, pro magnifica cruce tua in me sis, ut me ad
regnum tuum perducas, per D. N. J. C. Amen."

§ XLVIII. Although, however, this change in the tone of the Christian mind was most distinctly manifested when the revival of literature rendered the works of the heathen philosophers the leading study of all the greatest scholars of the period, it had been, as I said before, taking place gradually from the earliest ages. It is, as far as I know, that root of the Renaissance poison-tree, which, of all others, is deepest struck; showing itself in various measures through the writings of all the Fathers, of course exactly in proportion to the respect which they paid to classical authors, especially to Plato, Aristotle, and Cicero. The mode in which the pestilent study of that literature affected them may be well illustrated by the examination of a single passage from the works of one of the best of them, St. Ambrose, and of the mode in which that passage was then amplified and formulized by later writers.

§ XLIX. Plato, indeed, studied alone, would have done no one any harm. He is profoundly spiritual and capacious in all his views, and embraces the small systems of Aristotle and Cicero, as the solar system does the Earth. He seems to me especially remarkable for the sense of the great Christian virtue of Holiness, or sanctification; and for the sense of the presence of the Deity in all things, great or small, which always runs in a solemn undercurrent beneath his exquisite playfulness and irony; while all the merely moral virtues may be found in his writings defined in the most noble manner, as a great painter defines his figures, *without outlines*. But the imperfect scholarship of later ages seems to have gone to Plato, only to find in him the system of Cicero; which indeed was very definitely expressed by him. For it having been quickly felt by all men who strove, unhelped by Christian faith, to enter at the strait gate into the paths of virtue, that there were four characters of mind which were protective or preservative of all that was best in man, namely, Prudence, Justice, Courage, and Temperance,* these were afterwards,

* This arrangement of the cardinal virtues is said to have been first made by Archytas. See D'Ancarville's illustration of the three figures of Prudence, Fortitude, and Charity, in Selvatico's 'Cappellina degli Scrovegni,' Padua, 1836.

with most illogical inaccuracy, called cardinal *virtues*, Prudence being evidently no virtue, but an intellectual gift : but this inaccuracy arose partly from the ambiguous sense of the Latin word “*virtutes*,” which sometimes, in mediæval language, signifies virtues, sometimes powers (being occasionally used in the Vulgate for the word “*hosts*,” as in Psalm ciii. 21, cxlviii. 2, &c., while “*fortitudines*” and “*exercitus*” are used for the same word in other places), so that Prudence might properly be styled a power, though not properly a virtue ; and partly from the confusion of Prudence with Heavenly Wisdom. The real rank of these four virtues, if so they are to be called, is however properly expressed by the term “*cardinal*.” They are virtues of the compass, those by which all others are directed and strengthened ; they are not the greatest virtues, but the restraining or modifying virtues, thus Prudence restrains zeal, Justice restrains mercy, Fortitude and Temperance guide the entire system of the passions ; and, thus understood, these virtues properly assumed their peculiar leading or guiding position in the system of Christian ethics. But in Pagan ethics, they were not only guiding, but comprehensive. They meant a great deal more on the lips of the ancients, than they now express to the Christian mind. Cicero’s Justice includes charity, beneficence, and benignity, truth, and faith in the sense of trustworthiness. His Fortitude includes courage, self-command, the scorn of fortune and of all temporary felicities. His Temperance includes courtesy and modesty. So also, in Plato, these four virtues constitute the sum of education. I do not remember any more simple or perfect expression of the idea, than in the account given by Socrates, in the “*Alcibiades I.*,” of the education of the Persian kings, for whom, in their youth, there are chosen, he says, four tutors from among the Persian nobles ; namely, the Wisest, the most Just, the most Temperate, and the most Brave of them. Then each has a distinct duty : “*The Wisest teaches the young king the worship of the gods, and the duties of a king (something more here, observe, than our ‘Prudence !’)* ; the most Just teaches him to speak all truth, and to act out all truth, through the whole course of his life ; the most Tem-

perate teaches him to allow no pleasure to have the mastery of him, so that he may be truly free, and indeed a king ; and the most Brave makes him fearless of all things, showing him that the moment he fears anything, he becomes a slave."

§ L. All this is exceedingly beautiful, so far as it reaches ; but the Christian divines were grievously led astray by their endeavors to reconcile this system with the nobler law of love. At first, as in the passage I am just going to quote from St. Ambrose, they tried to graft the Christian system on the four branches of the Pagan one ; but finding that the tree would not grow, they planted the Pagan and Christian branches side by side ; adding, to the four cardinal virtues, the three called by the schoolmen theological, namely, Faith, Hope, and Charity : the one series considered as attainable by the Heathen, but the other by the Christian only. Thus Virgil to Sordello :

" Loco e laggiù, non tristo da martiri
Ma di tenebre solo, ove i lamenti
Non suonan come guai, ma son sospiri :

Quivi sto io, con quei che le tre sante
Virtù non si vestiro, e senza vizio
Conobber l' altre, e seguir, tutte quante."

. " There I with those abide
Who the Three Holy Virtues put not on,
But understood the rest, and without blame
Followed them all."

CARY.

§ LI. This arrangement of the virtues was, however, productive of infinite confusion and error : in the first place, because Faith is classed with its own fruits,—the gift of God, which is the root of the virtues, classed simply as one of them ; in the second, because the words used by the ancients to express the several virtues had always a different meaning from the same expressions in the Bible, sometimes a more extended, sometimes a more limited one. Imagine, for instance, the confusion which must have been introduced into

the ideas of a student who read St. Paul and Aristotle alternately ; considering that the word which the Greek writer uses for Justice, means, with St. Paul, Righteousness. And lastly, it is impossible to overrate the mischief produced in former days, as well as in our own, by the mere habit of reading Aristotle, whose system is so false, so forced, and so confused, that the study of it at our universities is quite enough to occasion the utter want of accurate habits of thought which so often disgraces men otherwise well-educated. In a word, Aristotle mistakes the Prudence or Temperance which must regulate the operation of the virtues, for the essence of the virtues themselves ; and, striving to show that all virtues are means between two opposite vices, torments his wit to discover and distinguish as many pairs of vices as are necessary to the completion of his system, not disdaining to employ sophistry where invention fails him.

And, indeed, the study of classical literature, in general, not only fostered in the Christian writers the unfortunate love of systematizing, which gradually degenerated into every species of contemptible formulism, but it accustomed them to work out their systems by the help of any logical quibble, or verbal subtlety, which could be made available for their purpose, and this not with any dishonest intention, but in a sincere desire to arrange their ideas in systematical groups, while yet their powers of thought were not accurate enough, nor their common sense stern enough, to detect the fallacy, or disdain the finesse, by which these arrangements were frequently accomplished.

§ LII. Thus St. Ambrose, in his commentary on Luke vi. 20, is resolved to transform the four Beatitudes there described into rewards of the four cardinal Virtues, and sets himself thus ingeniously to the task :

“ ‘Blessed be ye poor.’ Here you have Temperance. ‘Blessed are ye that hunger now.’ He who hungers, pities those who are an-hungered ; in pitying, he gives to them, and in giving he becomes just (*largiendo fit justus*). ‘Blessed are ye that weep now, for ye shall laugh.’ Here you have Prudence, whose part it is to weep, so far as present things

are concerned, and to seek things which are eternal. 'Blessed are ye when men shall hate you.' Here you have Fortitude."

§ LIII. As a preparation for this profitable exercise of wit, we have also a reconciliation of the Beatitudes as stated by St. Matthew, with those of St. Luke, on the ground that "in those eight are these four, and in these four are those eight;" with sundry remarks on the mystical value of the number eight, with which I need not trouble the reader. With St. Ambrose, however, this puerile systematization is quite subordinate to a very forcible and truthful exposition of the real nature of the Christian life. But the classification he employs furnishes ground for farther subtleties to future divines; and in a MS. of the thirteenth century I find some expressions in this commentary on St. Luke, and in the treatise on the duties of bishops, amplified into a treatise on the "Steps of the Virtues: by which every one who perseveres may, by a straight path, attain to the heavenly country of the Angels." ("Liber de Gradibus Virtutum: quibus ad patriam angelorum supernam itinere recto ascenditur ab omni perseverante.") These Steps are thirty in number (one expressly for each day of the month), and the curious mode of their association renders the list well worth quoting:

§ LIV. Primus gradus est	Fides Recta.	Unerring faith.
Secundus "	Spes firma.	Firm hope.
Tertius "	Caritas perfecta.	Perfect charity.
4. "	Patientia vera.	True patience.
5. "	Humilitas sancta.	Holy humility.
6. "	Mansuetudo.	Meekness.
7. "	Intelligentia.	Understanding.
8. "	Compunctio cordis.	Contrition of heart.
9. "	Oratio.	Prayer.
10. "	Confessio pura.	Pure confession.
11. "	Penitentia digna.	Fitting penance.*
12. "	Abstinencia.	Abstinence (fasting).
13. "	Timor Dei.	Fear of God.
14. "	Virginitas.	Virginity.

* Or Penitence: but I rather think this is understood only in *Compunctio cordis*.

15.	gradus est	Justicia.	Justice.
16.	"	Misericordia.	Mercy.
17.	"	Elemosina.	Almsgiving.
18.	"	Hospitalitas.	Hospitality.
19.	"	Honor parentum.	Honoring of parents.
20.	"	Silencium.	Silence.
21.	"	Consilium bonum.	Good counsel.
22.	"	Judicium rectum.	Right judgment.
23.	"	Exemplum bonum.	Good example.
24.	"	Visitatio infirmorum.	Visitation of the sick.
25.	"	Frequentatio sanctorum.	Companying with saints.
26.	"	Oblatio justa.	Just oblations.
27.	"	Decimas Deo solvere.	Paying tithes to God.
28.	"	Sapientia.	Wisdom.
29.	"	Voluntas bona.	Goodwill.
30.	"	Perseverantia.	Perseverance.

§ LV. The reader will note that the general idea of Christian virtue embodied in this list is true, exalted, and beautiful ; the points of weakness being the confusion of duties with virtues, and the vain endeavor to enumerate the various offices of charity as so many separate virtues ; more frequently arranged as seven distinct works of mercy. This general tendency to a morbid accuracy of classification was associated, in later times, with another very important element of the Renaissance mind, the love of personification ; which appears to have reached its greatest vigor in the course of the sixteenth century, and is expressed to all future ages, in a consummate manner, in the poem of Spenser. It is to be noted that personification is, in some sort, the reverse of symbolism, and is far less noble. Symbolism is the setting forth of a great truth by an imperfect and inferior sign (as, for instance, of the hope of the resurrection by the form of the phoenix) ; and it is almost always employed by men in their most serious moods of faith, rarely in recreation. Men who use symbolism forcibly are almost always true believers in what they symbolize. But Personification is the bestowing of a human or living form upon an abstract idea : it is, in most cases, a mere recreation of the fancy, and is apt to disturb the belief in the reality of the thing per-

sonified. Thus symbolism constituted the entire system of the Mosaic dispensation : it occurs in every word of Christ's teaching ; it attaches perpetual mystery to the last and most solemn act of His life. But I do not recollect a single instance of personification in any of His words. And as we watch, thenceforward, the history of the Church, we shall find the declension of its faith exactly marked by the abandonment of symbolism,* and the profuse employment of personification,—even to such an extent that the virtues came, at last, to be confused with the saints ; and we find in the later Litanies, St. Faith, St. Hope, St. Charity, and St. Chastity, invoked immediately after St. Clara and St. Bridget.

§ LVI. Nevertheless, in the hands of its early and earnest masters, in whom fancy could not overthrow the foundations of faith, personification is often thoroughly noble and lovely ; the earlier conditions of it being just as much more spiritual and vital than the later ones, as the still earlier symbolism was more spiritual than they. Compare, for instance, Dante's burning Charity, running and returning at the wheels of the chariot of God,—

“ So ruddy, that her form had scarce
Been known within a furnace of clear flame,”

with Reynolds's Charity, a nurse in a white dress, climbed upon by three children.† And not only so, but the number and nature of the virtues differ considerably in the statements of different poets and painters, according to their own views of religion, or to the manner of life they had it in mind to illustrate. Giotto, for instance, arranges his system altogether differently at Assisi, where he is setting forth the monkish life, and in the Arena Chapel, where he treats of that of mankind in general, and where, therefore, he gives only the so-called theological and cardinal virtues ; while, at Assisi,

* The transformation of a symbol into reality, observe, as in transubstantiation, is as much an abandonment of symbolism as the forgetfulness of symbolic meaning altogether.

† On the window of New College, Oxford.

the three principal virtues are those which are reported to have appeared in vision to St. Francis, Chastity, Obedience, and Poverty : Chastity being attended by Fortitude, Purity, and Penance ; Obedience by Prudence and Humility ; Poverty by Hope and Charity. The systems vary with almost every writer, and in almost every important work of art which embodies them, being more or less spiritual according to the power of intellect by which they were conceived. The most noble in literature are, I suppose, those of Dante and Spenser : and with these we may compare five of the most interesting series in the early art of Italy ; namely, those of Orcagna, Giotto, and Simon Memmi, at Florence and Padua, and those of St. Mark's and the Ducal Palace at Venice. Of course, in the richest of these series, the vices are personified together with the virtues, as in the Ducal Palace ; and by the form or name of opposed vice, we may often ascertain, with much greater accuracy than would otherwise be possible, the particular idea of the contrary virtue in the mind of the writer or painter. Thus, when opposed to Prudence, or Prudentia, on the one side, we find Folly, or Stultitia, on the other, it shows that the virtue understood by Prudence, is not the mere guiding or cardinal virtue, but the Heavenly Wisdom,* opposed to that folly which "hath said in its heart, there is no God ;" and of which it is said, "the thought of foolishness is sin ;" and again, "Such as be foolish shall not stand in thy sight." This folly is personified, in early painting and illumination, by a half-naked man, greedily eating an apple or other fruit, and brandishing a club ; showing that sensuality and violence are the two principal characteristics of Foolishness, and lead into atheism. The figure, in early Psalters, always forms the letter D, which commences the fifty-third Psalm, "*Dixit insipiens.*"

§ LVII. In reading Dante, this mode of reasoning from contraries is a great help, for his philosophy of the vices is the only one which admits of classification ; his descriptions of virtue, while they include the ordinary formal divisions

* Uniting the three ideas expressed by the Greek philosophers under the terms φρόνησις, σοφία, and ἐπιστήμη ; and part of the idea of σωφροσύνη

are far too profound and extended to be brought under definition. Every line of the "Paradise" is full of the most exquisite and spiritual expressions of Christian truth; and that poem is only less read than the "Inferno" because it requires far greater attention, and, perhaps, for its full enjoyment, a holier heart.

§ LVIII. His system in the "Inferno" is briefly this. The whole nether world is divided into seven circles, deep within deep, in each of which, according to its depth, severer punishment is inflicted. These seven circles, reckoning them downwards, are thus allotted:

1. To those who have lived virtuously, but knew not Christ.
2. To Lust.
3. To Gluttony.
4. To Avarice and Extravagance.
5. To Anger and *Sorrow*.
6. To Heresy.
7. To Violence and Fraud.

This seventh circle is divided into two parts; of which the first, reserved for those who have been guilty of Violence, is again divided into three, apportioned severally to those who have committed, or desired to commit, violence against their neighbors, against themselves, or against God.

The lowest hell, reserved for the punishment of Fraud, is itself divided into ten circles, wherein are severally punished the sins of,—

1. Betraying women.
2. Flattery.
3. Simony.
4. False prophecy.
5. Peculation.
6. Hypocrisy.
7. Theft.
8. False counsel.
9. Schism and Imposture.
10. Treachery to those who repose entire trust in the traitor.

§ LIX. There is, perhaps, nothing more notable in this most interesting system than the profound truth couched under the attachment of so terrible a penalty to sadness or sorrow. It is true that Idleness does not elsewhere appear in the scheme, and is evidently intended to be included in the guilt of sadness by the word "accidioso;" but the main meaning of the poet is to mark the duty of rejoicing in God, according both to St. Paul's command, and Isaiah's promise, "Thou meetest him that rejoiceth and worketh righteousness."* I do not know words that might with more benefit be borne with us, and set in our hearts momentarily against the minor regrets and rebelliousnesses of life, than these simple ones :

"Tristi fummo
Nel aer dolce, che del sol s' allegra,
Or ci attristiam, nella belletta negra."

"We once were sad,
In the sweet air, made gladsome by the sun,
Now in these murky settlings are we sad." † CARY.

The virtue usually opposed to this vice of sullenness is Alacritas, uniting the sense of activity and cheerfulness. Spenser has cheerfulness simply, in his description, never enough to be loved or praised, of the virtues of Womanhood; first feminineness or womanhood in specialty; then,—

"Next to her sate goodly Shamefastnesse,
Ne ever durst her eyes from ground upreare,
Ne ever once did looke up from her desse, †
As if some blame of evill she did feare
That in her cheekes made roses oft appeare :
And her against sweet Cherefulness was placed,
Whose eyes, like twinkling stars in evening cleare,
Were deckt with smyles that all sad humours chased.

* Isa. lxiv. 5.

† I can hardly think it necessary to point out to the reader the association between sacred cheerfulness and solemn thought, or to explain any appearance of contradiction between passages in which (as above in Chap. V.) I have had to oppose sacred pensiveness to unholy mirth, and those in which I have to oppose sacred cheerfulness to unholy sorrow.

‡ "Desse," seat.

“ And next to her sate sober Modestie,
 Holding her hand upon her gentle hart ;
 And her against, sate comely Curtesie,
That unto every person knew her part ;
 And her before was seated overthwart
 Soft Silence, and submisse Obedience,
 Both linckt together never to dispart.”

§ LX. Another notable point in Dante's system is the intensity of uttermost punishment given to treason, the peculiar sin of Italy, and that to which, at this day, she attributes her own misery with her own lips. An Italian, questioned as to the causes of the failure of the campaign of 1848, always makes one answer, “ We were betrayed ; ” and the most melancholy feature of the present state of Italy is principally this, that she does not see that, of all causes to which failure might be attributed, this is at once the most disgraceful, and the most hopeless. In fact, Dante seems to me to have written almost prophetically, for the instruction of modern Italy, and chiefly so in the sixth canto of the “ Purgatorio.”

§ LXI. Hitherto we have been considering the system of the “ Inferno ” only. That of the “ Purgatorio ” is much simpler, it being divided into seven districts, in which the souls are severally purified from the sins of Pride, Envy, Wrath, Indifference, Avarice, Gluttony, and Lust ; the poet thus implying in opposition, and describing in various instances, the seven virtues of Humility, Kindness, * Patience, Zeal, Poverty, Abstinence, and Chastity, as adjuncts of the Christian character, in which it may occasionally fail, while the essential group of the three theological and four cardinal virtues are represented as in direct attendance on the chariot of the Deity ; and all the sins of Christians are in the seventeenth canto traced to the deficiency or aberration of Affection.

* Usually called Charity : but this virtue in its full sense is one of the attendant spirits by the Throne ; the Kindness here meant is Charity with a special object ; or Friendship and Kindness, as opposed to Envy, which has always, in like manner, a special object. Hence the love of Orestes and Pylades is given as an instance of the virtue of Friendship ; and the Virgin's, “ They have no wine,” at Cana, of general kindness and sympathy with others' pleasure.

§ LXII. The system of Spenser is unfinished, and exceedingly complicated, the same vices and virtues occurring under different forms in different places, in order to show their different relations to each other. I shall not therefore give any general sketch of it, but only refer to the particular personification of each virtue in order to compare it with that of the Ducal Palace.* The peculiar superiority of his system is in its exquisite setting forth of Chastity under the figure of Britomart; not monkish chastity, but that of the purest Love. In completeness of personification no one can approach him; not even in Dante do I remember anything quite so great as the description of the Captain of the Lusts of the Flesh :

“As pale and wan as ashes was his looke ;
 His body lean and meagre as a rake ;
 And skin all withered like a dryed rooke ;
 Thoreto as cold and drery as a snake ;
 That seemed to tremble evermore, and quake :
All in a canvas thin he was bedight,
And girded with a belt of twisted brake :
 Upon his head he wore an helmet light,
 Made of a dead man's skull.”

He rides upon a tiger, and in his hand is a bow, bent ;

“And many arrows under his right side,
 Headed with flint, and fethers bloody dide.”

The horror and the truth of this are beyond everything that I know, out of the pages of Inspiration. Note the heading of the arrows with flint, because sharper and more subtle in the edge than steel, and because steel might consume away with rust, but flint not ; and consider in the whole description how the wasting away of body and soul together, and the *coldness*

* The “Faerie Queen,” like Dante’s “Paradise,” is only half estimated, because few persons take the pains to think out its meaning. I have put a brief analysis of the first book in Appendix 2, Vol. III. ; which may perhaps induce the reader to follow out the subject for himself. No time devoted to profane literature will be better rewarded than that spent *earnestly* on Spenser.

of the heart, which unholy fire has consumed into ashes, and the loss of all power, and the kindling of all terrible impatience, and the implanting of thorny and inextricable griefs, are set forth by the various images, the belt of brake, the tiger steed, and the *light* helmet, girding the head with death.

§ LXIII. Perhaps the most interesting series of the Virtues expressed in Italian art are those above mentioned of Simon Memmi in the Spanish chapel at Florence, of Ambrogio di Lorenzo in the Palazzo Publico of Pisa, of Orcagna in Or San Michele at Florence, of Giotto at Padua and Assisi, in mosaic on the central cupola of St. Mark's, and in sculpture on the pillars of the Ducal Palace. The first two series are carefully described by Lord Lindsay; both are too complicated for comparison with the more simple series of the Ducal Palace; the other four of course agree in giving first the cardinal and evangelical virtues; their variations in the statement of the rest will be best understood by putting them in a parallel arrangement.

ST. MARK'S.	ORCAGNA.	GIOTTO.	DUCAL PALACE.
Constancy.	Perseverance.		Constancy.
Modesty.			Modesty.
Chastity.	Virginity.	Chastity.	Chastity.
Patience.	Patience.		Patience.
Mercy.			
Abstinence.			Abstinence?
Piety.*	Devotion.		
Benignity.			
Humility.	Humility.	Humility.	Humility.
	Obedience.	Obedience.	Obedience.
	Docility.		
	Caution.		
		Poverty.	<i>Honesty.</i>
			<i>Liberality.</i>
			<i>Alacrity.</i>

* Inscribed, I believe, Pietas, meaning general reverence and godly fear.

§ LXIV. It is curious, that in none of these lists do we find either *Honesty* or *Industry* ranked as a virtue, except in the Venetian one, where the latter is implied in *Alacritas*, and opposed not only by "Accidia" or sloth, but by a whole series of eight sculptures on another capital, illustrative, as I believe, of the temptations to idleness ; while various other capitals, as we shall see presently, are devoted to the representation of the active trades. Industry, in Northern art and Northern morality, assumes a very principal place. I have seen in French manuscripts the virtues reduced to these seven, Charity, Chastity, Patience, Abstinence, Humility, Liberality, and Industry : and I doubt whether, if we were but to add *Honesty* (or *Truth*), a wiser or shorter list could be made out.

§ LXV. We will now take the pillars of the Ducal Palace in their order. It has already been mentioned (Vol. I. Chap. I. § XLVI.) that there are, in all, thirty-six great pillars supporting the lower story ; and that these are to be counted from right to left, because then the more ancient of them come first : and that, thus arranged, the first, which is not a shaft, but a pilaster, will be the support of the Vine angle ; the eighteenth will be the great shaft of the Fig-tree angle ; and the thirty-sixth, that of the Judgment angle.

§ LXVI. All their capitals, except that of the first, are octagonal, and are decorated by sixteen leaves, differently enriched in every capital, but arranged in the same way ; eight of them rising to the angles, and there forming volutes ; the eight others set between them, on the sides, rising half-way up the bell of the capital ; there nodding forward, and showing above them, rising out of their luxuriance, the groups or single figures which we have to examine.* In some instances, the intermediate or lower leaves are reduced to eight sprays of foliage ; and the capital is left dependent for its effect on the bold position of the figures. In referring to the figures

* I have given one of these capitals carefully already in my folio work, and hope to give most of the others in due time. It was of no use to draw them here, as the scale would have been too small to allow me to show the expression of the figures.

on the octagonal capitals, I shall call the outer side, fronting either the Sea or the Piazzetta, the first side ; and so count round from left to right ; the fourth side being thus, of course, the innermost. As, however, the first five arches were walled up after the great fire, only three sides of their capitals are left visible, which we may describe as the front and the eastern and western sides of each.

§ LXVII. FIRST CAPITAL: i.e. of the pilaster at the Vine angle.

In front, towards the Sea. A child holding a bird before him, with its wings expanded, covering his breast.

On its eastern side. Children's heads among leaves.

On its western side. A child carrying in one hand a comb ; in the other, a pair of scissors.

It appears curious, that this, the principal pilaster of the façade, should have been decorated only by these graceful grotesques, for I can hardly suppose them anything more. There may be meaning in them, but I will not venture to conjecture any, except the very plain and practical meaning conveyed by the last figure to all Venetian children, which it would be well if they would act upon. For the rest, I have seen the comb introduced in grotesque work as early as the thirteenth century, but generally for the purpose of ridiculing too great care in dressing the hair, which assuredly is not its purpose here. The children's heads are very sweet and full of life, but the eyes sharp and small.

§ LXVIII. SECOND CAPITAL. Only three sides of the original work are left unburied by the mass of added wall. Each side has a bird, one web-footed, with a fish, one clawed, with a serpent, which opens its jaws, and darts its tongue at the bird's breast ; the third pluming itself, with a feather between the mandibles of its bill. It is by far the most beautiful of the three capitals decorated with birds.

THIRD CAPITAL. Also has three sides only left. They have three heads, large, and very ill cut ; one female, and crowned.

FOURTH CAPITAL. Has three children. The eastern one is defaced : the one in front holds a small bird, whose plumage is beautifully indicated, in its right hand ; and with its left

holds up half a walnut, showing the nut inside : the third holds a fresh fig, cut through, showing the seeds.

The hair of all the three children is differently worked : the first has luxuriant flowing hair, and a double chin ; the second, light flowing hair falling in pointed locks on the forehead ; the third, crisp curling hair, deep cut with drill holes.

This capital has been copied on the Renaissance side of the palace, only with such changes in the ideal of the children as the workman thought expedient and natural. It is highly interesting to compare the child of the fourteenth with the child of the fifteenth century. The early heads are full of youthful life, playful, humane, affectionate, beaming with sensation and vivacity, but with much manliness and firmness, also, not a little cunning, and some cruelty perhaps, beneath all ; the features small and hard, and the eyes keen. There is the making of rough and great men in them. But the children of the fifteenth century are dull smooth-faced dunces, without a single meaning line in the fatness of their stolid cheeks ; and, although, in the vulgar sense, as handsome as the other children are ugly, capable of becoming nothing but perfumed coxcombs.

FIFTH CAPITAL. Still three sides only left, bearing three half-length statues of kings ; this is the first capital which bears any inscription. In front, a king with a sword in his right hand points to a handkerchief embroidered and fringed, with a head on it, carved on the cavetto of the abacus. His name is written above, "TITUS VESPASIAN IMPERATOR" (contracted

IPAT.).

On the eastern side, "TRAJANUS IMPERATOR." Crowned, a sword in right hand, and sceptre in left.

On western, "(OCT)AVIANUS AUGUSTUS IMPERATOR." The "OCT" is broken away. He bears a globe in his right hand, with "MUNDUS PACIS" upon it ; a sceptre in his left, which I think has terminated in a human figure. He has a flowing beard, and a singularly high crown ; the face is much injured, but has once been very noble in expression.

SIXTH CAPITAL. Has large male and female heads, very coarsely cut, hard, and bad.

§ LXIX. SEVENTH CAPITAL. This is the first of the series which is complete; the first open arch of the lower arcade being between it and the sixth. It begins the representation of the Virtues.

First side. Largitas, or Liberality: always distinguished from the higher Charity. A male figure, with his lap full of money, which he pours out of his hand. The coins are plain, circular, and smooth; there is no attempt to mark device upon them. The inscription above is, "LARGITAS ME ONORAT."

In the copy of this design on the twenty-fifth capital, instead of showering out the gold from his open hand, the figure holds it in a plate or salver, introduced for the sake of disguising the direct imitation. The changes thus made in the Renaissance pillars are always injuries.

This virtue is the proper opponent of Avarice; though it does not occur in the systems of Orcagna or Giotto, being included in Charity. It was a leading virtue with Aristotle and the other ancients.

§ LXX. *Second side.* Constancy; not very characteristic. An armed man with a sword in his hand, inscribed, "CONSTANTIA SUM, NIL TIMENS."

This virtue is one of the forms of fortitude, and Giotto therefore sets as the vice opponent to Fortitude, "Inconstantia," represented as a woman in loose drapery, falling from a rolling globe. The vision seen in the interpreter's house in the Pilgrim's Progress, of the man with a very bold countenance, who says to him who has the writer's ink-horn by his side, "Set down my name," is the best personification of the Venetian "Constantia" of which I am aware in literature. It would be well for us all to consider whether we have yet given the order to the man with the ink-horn, "Set down my name."

§ LXXI. *Third side.* Discord; holding up her finger, but needing the inscription above to assure us of her meaning, "DISCORDIA SUM, DISCORDANS." In the Renaissance copy she is a meek and nun-like person with a veil.

She is the Atë of Spenser ; “mother of debate,” thus described in the fourth book :

“ Her face most fowle and filthy was to see,
 With squinted eyes contrarie wayes intended ;
 And loathly mouth, unmeete a mouth to bee,
 That nought but gall and venim comprehended,
 And wicked wordes that God and man offended :
 Her lying tongue was in two parts divided,
 And both the parts did speake, and both contended ;
 And as her tongue, so was her hart discided,
 That never thoght one thing, but doubly stil was guided.”

Note the fine old meaning of “discided,” cut in two ; it is a great pity we have lost this powerful expression. We might keep “determined” for the other sense of the word.

§ LXXII. *Fourth side.* Patience. A female figure, very expressive and lovely, in a hood, with her right hand on her breast, the left extended, inscribed “PATIENTIA MANET MECUM.”

She is one of the principal virtues in all the Christian systems : a masculine virtue in Spenser, and beautifully placed as the *Physician* in the House of Holinesse. The opponent vice, Impatience, is one of the hags who attend the Captain of the Lusts of the Flesh ; the other being Impotence. In like manner, in the “Pilgrim’s Progress,” the opposite of Patience is Passion ; but Spenser’s thought is farther carried. His two hags, Impatience and Impotence, as attendant upon the evil spirit of Passion, embrace all the phenomena of human conduct, down even to the smallest matters, according to the adage, “More haste, worse speed.”

§ LXXIII. *Fifth side.* Despair. A female figure thrusting a dagger into her throat, and tearing her long hair, which flows down among the leaves of the capital below her knees. One of the finest figures of the series ; inscribed “DESPERACIO MÔS (mortis?) CRUDELIS.” In the Renaissance copy she is totally devoid of expression, and appears, instead of tearing her hair, to be dividing it into long curls on each side.

This vice is the proper opposite of Hope. By Giotto she is represented as a woman hanging herself, a fiend coming for

her soul. Spenser's vision of Despair is well known, it being indeed currently reported that this part of the Faerie Queen was the first which drew to it the attention of Sir Philip Sidney.

§ LXXIV. *Sixth side.* Obedience: with her arms folded meek, but rude and commonplace, looking at a little dog standing on its hind legs and begging, with a collar round its neck. Inscribed "OBEDIENTI * * ;" the rest of the sentence

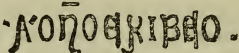
is much defaced, but looks like . I suppose the note of contraction above the final A has disappeared and that the inscription was "Obedientiam domino exhibeo."

This virtue is, of course, a principal one in the monkish systems; represented by Giotto at Assisi as "an angel robed in black, placing the finger of his left hand on his mouth, and passing the yoke over the head of a Franciscan monk kneeling at his feet." *

Obedience holds a less principal place in Spenser. We have seen her above associated with the other peculiar virtues of womanhood.

§ LXXV. *Seventh side.* Infidelity. A man in a turban, with a small image in his hand, or the image of a child. Of the inscription nothing but "INFIDELITATE * * *" and some fragmentary letters, "ILI, CERO," remain.

By Giotto Infidelity is most nobly symbolized as a woman helmeted, the helmet having a broad rim which keeps the light from her eyes. She is covered with heavy drapery, stands infirmly as if about to fall, is bound by a cord round her neck to an image which she carries in her hand, and has flames bursting forth at her feet.

In Spenser, Infidelity is the Saracen knight Sans Foy,—

"Full large of limbe and every joint
He was, and carèd not for God or man a point."

For the part which he sustains in the contest with Godly Fear, or the Red-cross knight, see Appendix 2, Vol. III.

* Lord Lindsay, vol. ii. p. 226.

§ LXXVI. *Eighth side.* Modesty ; bearing a pitcher. (In the Renaissance copy, a vase like a coffee-pot.) Inscribed “MODESTIA

ROBUORATIŃDO.”

I do not find this virtue in any of the Italian series, except that of Venice. In Spenser she is of course one of those attendant on Womanhood, but occurs as one of the tenants of the Heart of Man, thus portrayed in the second book :

“Strange was her tyre, and all her garment blew,
Close rownd about her tuckt with many a plight :
Upon her fist the bird which shoneth vew.

.

And ever and anone with rosy red
The bashfull blood her snowy cheekes did dye,
That her became, as polisht yvory
Which cunning craftsman hand hath overlaid
With fayre vermilion or pure castory.”

§ LXXVII. EIGHTH CAPITAL. It has no inscriptions, and its subjects are not, by themselves, intelligible ; but they appear to be typical of the degradation of human instincts.

First side. A caricature of Arion on his dolphin ; he wears a cap ending in a long proboscis-like horn, and plays a violin with a curious twitch of the bow and wag of the head, very graphically expressed, but still without anything approaching to the power of Northern grotesque. His dolphin has a godly row of teeth, and the waves beat over his back.

Second side. A human figure, with curly hair and the legs of a bear ; the paws laid, with great sculptural skill, upon the foliage. It plays a violin, shaped like a guitar, with a bent double-stringed bow.

Third side. A figure with a serpent's tail and a monstrous head, founded on a Negro type, hollow-cheeked, large-lipped, and wearing a cap made of a serpent's skin, holding a fir-cone in its hand.

Fourth side. A monstrous figure, terminating below in a tortoise. It is devouring a gourd, which it grasps greedily with both hands ; it wears a cap ending in a hoofed leg.

Fifth side. A centaur wearing a crested helmet, and holding a curved sword.

Sixth side. A knight, riding a headless horse, and wearing chain armor, with a triangular shield flung behind his back, and a two-edged sword.

Seventh side. A figure like that on the fifth, wearing a round helmet, and with the legs and tail of a horse. He bears a long mace with a top like a fir-cone.

Eighth side. A figure with curly hair, and an acorn in its hand, ending below in a fish.

§ LXXVIII. NINTH CAPITAL. *First side.* Faith. She has her left hand on her breast, and the cross on her right. Inscribed "FIDES OPTIMA IN DEO." The Faith of Giotto holds the cross in her right hand; in her left, a scroll with the Apostles' Creed. She treads upon cabalistic books, and has a key suspended to her waist. Spenser's Faith (Fidelia) is still more spiritual and noble:

"She was araied all in lilly white,
 And in her right hand bore a cup of gold,
 With wine and water fild up to the hight,
 In which a serpent did himselfe enfold,
 That horroure made to all that did behold;
 But she no whitt did chaunge her constant mood;
 And in her other hand she fast did hold
 A booke, that was both signd and seald with blood;
 Wherein darke things were writt, hard to be understood."

§ LXXIX. *Second side.* Fortitude. A long-bearded man [Samson?] tearing open a lion's jaw. The inscription is illegible, and the somewhat vulgar personification appears to belong rather to Courage than Fortitude. On the Renaissance copy it is inscribed "FORTITUDO SUM VIRILIS." The Latin word has, perhaps, been received by the sculptor as merely signifying "Strength," the rest of the perfect idea of this virtue having been given in "Constantia" previously. But both these Venetian symbols together do not at all approach the idea of Fortitude as given generally by Giotto and the Pisan sculptors; clothed with a lion's skin, knotted about her neck, and falling to her feet in deep folds; drawing back

her right hand, with the sword pointed towards her enemy, and slightly retired behind her immovable shield, which, with Giotto, is square, and rested on the ground like a tower, covering her up to above her shoulders; bearing on it a lion, and with broken heads of javelins deeply infixéd.

Among the Greeks, this is, of course, one of the principal virtues; apt, however, in their ordinary conception of it to degenerate into mere manliness or courage.

§ LXXX. *Third side.* Temperance; bearing a pitcher of water and a cup. Inscription, illegible here, and on the Renaissance copy nearly so, "TEMPERANTIA SUM" (INOM' L^s)? only left. In this somewhat vulgar and most frequent conception of this virtue (afterwards continually repeated, as by Sir Joshua in his window at New College) temperance is confused with mere abstinence, the opposite of Gula, or gluttony; whereas the Greek Temperance, a truly cardinal virtue, is the moderator of *all* the passions, and so represented by Giotto, who has placed a bridle upon her lips, and a sword in her hand, the hilt of which she is binding to the scabbard. In his system, she is opposed among the vices, not by Gula or Gluttony, but by Ira, Anger. So also the Temperance of Spenser, or Sir Guyon, but with mingling of much sternness:

"A goodly knight, all armed in harnesse meete,
That from his head no place appeared to his feete,
His carriage was full comely and upright;
His countenance demure and temperate;
But yett so sterne and terrible in sight,
That cheard his friendes, and did his foes amate."

The Temperance of the Greeks, *σωφροσύνη*, involves the idea of Prudence, and is a most noble virtue, yet properly marked by Plato as inferior to sacred enthusiasm, though necessary for its government. He opposes it, under the name "Mortal Temperance" or "the Temperance which is of men," to divine madness, *μανία*, or inspiration; but he most justly and nobly expresses the general idea of it under the term *ὑβρις*, which, in the "Phædrus," is divided into various intemperances with respect to various objects, and set forth under

the image of a black, vicious, diseased and furious horse, yoked by the side of Prudence or Wisdom (set forth under the figure of a white horse with a crested and noble head, like that which we have among the Elgin Marbles) to the chariot of the Soul. The system of Aristotle, as above stated, is throughout a mere complicated blunder, supported by sophistry, the laboriously developed mistake of Temperance for the essence of the virtues which it guides. Temperance in the mediæval systems is generally opposed by Anger, or by Folly, or Gluttony : but her proper opposite is Spenser's Acrasia, the principal enemy of Sir Guyon, at whose gates we find the subordinate vice "Excesse," as the introduction to Intemperance ; a graceful and feminine image, necessary to illustrate the more dangerous forms of subtle intemperance, as opposed to the brutal "Gluttony" in the first book. She presses grapes into a cup, because of the words of St. Paul, "Be not drunk with wine, wherein is excess ;" but always delicately,

"Into her cup she scruzd with daintie breach
Of her fine fingers, without fowle empeach,
That so faire winepresse made the wine more sweet."

The reader will, I trust, pardon these frequent extracts from Spenser, for it is nearly as necessary to point out the profound divinity and philosophy of our great English poet, as the beauty of the Ducal Palace.

§ LXXXI. *Fourth side.* Humility ; with a veil upon her head, carrying a lamp in her lap. Inscribed in the copy, "HUMILITAS HABITAT IN ME."

This virtue is of course a peculiarly Christian one, hardly recognized in the Pagan systems, though carefully impressed upon the Greeks in early life in a manner which at this day it would be well if we were to imitate, and, together with an almost feminine modesty, giving an exquisite grace to the conduct and bearing of the well-educated Greek youth. It is, of course, one of the leading virtues in all the monkish systems, but I have not any notes of the manner of its representation.

§ LXXXII. *Fifth side.* Charity. A woman with her lap full of

loaves (?), giving one to a child, who stretches his arm out for it across a broad gap in the leafage of the capital.

Again very far inferior to the Giottesque rendering of this virtue. In the Arena Chapel she is distinguished from all the other virtues by having a circular glory round her head, and a cross of fire; she is crowned with flowers, presents with her right hand a vase of corn and fruit, and with her left receives treasure from Christ, who appears above her, to provide her with the means of continual offices of beneficence, while she tramples under foot the treasures of the earth.

The peculiar beauty of most of the Italian conceptions of Charity, is in the subjection of mere munificence to the glowing of her love, always represented by flames; here in the form of a cross round her head; in Orcagna's shrine at Florence, issuing from a censer in her hand; and, with Dante, inflaming her whole form, so that, in a furnace of clear fire, she could not have been discerned.

Spenser represents her as a mother surrounded by happy children, an idea afterwards grievously hackneyed and vulgarized by English painters and sculptors.

§ LXXXIII. *Sixth side.* Justice. Crowned, and with sword. Inscribed in the copy, "REX SUM JUSTICIE."

This idea was afterwards much amplified and adorned in the only good capital of the Renaissance series, under the Judgment angle. Giotto has also given his whole strength to the painting of this virtue, representing her as enthroned under a noble Gothic canopy, holding scales, not by the beam, but one in each hand; a beautiful idea, showing that the equality of the scales of Justice is not owing to natural laws, but to her own immediate weighing the opposed causes in her own hands. In one scale is an executioner beheading a criminal; in the other an angel crowning a man who seems (in Selvatico's plate) to have been working at a desk or table.

Beneath her feet is a small predella, representing various persons riding securely in the woods, and others dancing to the sound of music.

Spenser's Justice, Sir Artégall, is the hero of an entire book, and the betrothed knight of Britomart, or chastity.

§ LXXXIV. *Seventh side.* Prudence. A man with a book and a pair of compasses, wearing the noble cap, hanging down towards the shoulder, and bound in a fillet round the brow, which occurs so frequently during the fourteenth century in Italy in the portraits of men occupied in any civil capacity.

This virtue is, as we have seen, conceived under very different degrees of dignity, from mere worldly prudence up to heavenly wisdom, being opposed sometimes by Stultitia, sometimes by Ignorantia. I do not find, in any of the representations of her, that her truly distinctive character, namely, *forethought*, is enough insisted upon: Giotto expresses her vigilance and just measurement or estimate of all things by painting her as Janus-headed, and gazing into a convex mirror, with compasses in her right hand; the convex mirror showing her power of looking at many things in small compass. But forethought or anticipation, by which, independently of greater or less natural capacities, one man becomes more *prudent* than another, is never enough considered or symbolized.

The idea of this virtue oscillates, in the Greek systems, between Temperance and Heavenly Wisdom.

§ LXXXV. *Eighth side.* Hope. A figure full of devotional expression, holding up its hands as in prayer, and looking to a hand which is extended towards it out of sunbeams. In the Renaissance copy this hand does not appear.

Of all the virtues, this is the most distinctively Christian (it could not, of course, enter definitely into any Pagan scheme); and above all others, it seems to me the *testing* virtue,—that by the possession of which we may most certainly determine whether we are Christians or not; for many men have charity, that is to say, general kindness of heart, or even a kind of faith, who have not any habitual *hope* of, or longing for, heaven. The Hope of Giotto is represented as winged, rising in the air, while an angel holds a crown before her. I do not know if Spenser was the first to introduce our marine virtue, leaning on an anchor, a symbol as inaccurate as it is vulgar; for, in the first place, anchors are not for men, but for ships; and in the second, anchorage is the characteristic not of Hope, but of Faith. Faith is dependent, but Hope is aspirant.

Spenser, however, introduces Hope twice,—the first time as the Virtue with the anchor; but afterwards fallacious Hope, far more beautifully, in the Masque of Cupid:

“She always smyld, and in her hand did hold
An holy-water sprinckle, dipt in deowe.”

§ LXXXVI. TENTH CAPITAL. *First side.* Luxury (the opposite of chastity, as above explained). A woman with a jewelled chain across her forehead, smiling as she looks into a mirror, exposing her breast by drawing down her dress with one hand. Inscribed “LUXURIA SUM IMENSA.”

These subordinate forms of vice are not met with so frequently in art as those of the opposite virtues, but in Spenser we find them all. His Luxury rides upon a goat:

“In a greene gowne he clothed was full faire,
Which underneath did hide his filthinesse,
And in his hand a burning hart he bare.”

But, in fact, the proper and comprehensive expression of this vice is the Cupid of the ancients; and there is not any minor circumstance more indicative of the *intense* difference between the mediæval and the Renaissance spirit, than the mode in which this god is represented.

I have above said, that all great European art is rooted in the thirteenth century; and it seems to me that there is a kind of central year about which we may consider the energy of the middle ages to be gathered; a kind of focus of time which, by what is to my mind a most touching and impressive Divine appointment, has been marked for us by the greatest writer of the middle ages, in the first words he utters; namely, the year 1300, the “*mezzo del cammin*” of the life of Dante. Now, therefore, to Giotto, the contemporary of Dante, and who drew Dante’s still existing portrait in this very year, 1300, we may always look for the central mediæval idea in any subject: and observe how he represents Cupid; as one of three, a terrible trinity, his companions being Satan and Death; and he himself “a lean scarecrow, with bow, quiver, and fillet, and

feet ending in claws,"* thrust down into Hell by Penance; from the presence of Purity and Fortitude. Spenser, who has been so often noticed as furnishing the exactly intermediate type of conception between the mediæval and the Renaissance, indeed represents Cupid under the form of a beautiful winged god, and riding on a lion, but still no plaything of the Graces, but full of terror :

“With that the darts which his right hand did straine
Full dreadfully he shooke, that all did quake,
And clapt on hye his coloured winges twaine,
That all his many it afraide did make.”

His *many*, that is to say, his company ; and observe what a company it is. Before him go Fancy, Desire, Doubt, Danger, Fear, Fallacious Hope, Dissemblance, Suspicion, Grief, Fury, Displeasure, Despite, and Cruelty. After him, Reproach, Repentance, Shame,

“Unquiet Care, and fond Unthriftyhead,
Lewd Losse of Time, and Sorrow seeming dead,
Inconstant Chaunge, and false Disloyalty,
Consuming Riotise, and guilty Dread
Of heavenly vengeance ; faint Infirmity,
Vile Poverty, and lastly Death with infamy.”

Compare these two pictures of Cupid with the Love-god of the Renaissance, as he is represented to this day, confused with angels, in every faded form of ornament and allegory, in our furniture, our literature, and our minds.

§ LXXXVII. *Second side.* Gluttony. A woman in a turban, with a jewelled cup in her right hand. In her left, the clawed limb of a bird, which she is gnawing. Inscribed “GULA SINR ORDINE SUM.”

Spenser's Gluttony is more than usually fine :

“His belly was upblowne with luxury,
And eke with fatnesse swollen were his eyne,
And like a crane his necke was long and fyne,
Wherewith he swallowed up excessive feast,
For want whereof poore people oft did pyne.”

* Lord Lindsay, vol. ii. letter iv.

He rides upon a swine, and is clad in vine-leaves, with a garland of ivy. Compare the account of Excesse, above, as opposed to Temperance.

§ LXXXVIII. *Third side.* Pride. A knight, with a heavy and stupid face, holding a sword with three edges: his armor covered with ornaments in the form of roses, and with two ears attached to his helmet. The inscription indecipherable, all but "SUPERBIA."

Spenser has analyzed this vice with great care. He first represents it as the Pride of life; that is to say, the pride which runs in a deep under current through all the thoughts and acts of men. As such, it is a feminine vice, directly opposed to Holiness, and mistress of a castle called the House of Pryde, and her chariot is driven by Satan, with a team of beasts, ridden by the mortal sins. In the throne chamber of her palace she is thus described:

"So proud she shyned in her princely state,
Looking to Heaven, for Earth she did disdayne;
And sitting high, for lowly she did hate:
Lo, underneath her scornfull feete was layne
A dreadfull dragon with an hideous trayne;
And in her hand she held a mirrhour bright,
Wherein her face she often vewed fayne."

The giant Orgoglio is a baser species of pride, born of the Earth and Eolus; that is to say, of sensual and vain conceits. His foster-father and the keeper of his castle is Ignorance. (Book I. canto VIII.)

Finally, Disdain is introduced, in other places, as the form of pride which vents itself in insult to others.

§ LXXXIX. *Fourth side.* Anger. A woman tearing her dress open at her breast. Inscription here undecipherable; but in the Renaissance copy it is "IRA CRUDELIS EST IN ME."

Giotto represents this vice under the same symbol; but it is the weakest of all the figures in the Arena Chapel. The "Wrath" of Spenser rides upon a lion, brandishing a fire-brand, his garments stained with blood. Rage, or Furor, occurs subordinately in other places. It appears to me very

strange that neither Giotto nor Spenser should have given any representation of the *restrained Anger*, which is infinitely the most terrible ; both of them make him violent.

§ xc. *Fifth side.* Avarice. An old woman with a veil over her forehead, and a bag of money in each hand. A figure very marvellous for power of expression. The throat is all made up of sinews with skinny channels deep between them, strained as by anxiety, and wasted by famine ; the features hunger-bitten, the eyes hollow, the look glaring and intense, yet without the slightest caricature. Inscribed in the Renaissance copy, "AVARITIA IMPLETOR."

Spenser's Avarice (the vice) is much feebler than this ; but the god Mammon and his kingdom have been described by him with his usual power. Note the position of the house of Richesse :

"Betwixt them both was but a little stride,
That did the House of Richesse from Hell-mouth divide."

It is curious that most moralists confuse avarice with covetousness, although they are vices totally different in their operation on the human heart, and on the frame of society. The love of money, the sin of Judas and Ananias, is indeed the root of all evil in the hardening of the heart ; but "covetousness, which is idolatry," the sin of Ahab, that is, the inordinate desire of some seen or recognized good,—thus destroying peace of mind,—is probably productive of much more misery in heart, and error in conduct, than avarice itself, only covetousness is not so inconsistent with Christianity : for covetousness may partly proceed from vividness of the affections and hopes, as in David, and be consistent with much charity ; not so avarice.

§ xci. *Sixth side.* Idleness. Accidia. A figure much broken away, having had its arms round two branches of trees.

I do not know why Idleness should be represented as among trees, unless, in the Italy of the fourteenth century, forest country was considered as desert, and therefore the

domain of Idleness. Spenser fastens this vice especially upon the clergy,—

“Upon a slouthfull asse he chose to ryde,
 Arayd in habit blacke, and amis thin,
 Like to an holy monck, the service to begin.
 And in his hand his portesse still he bare,
 That much was worne, but therein little redd.”

And he properly makes him the leader of the train of the vices :

“May seem the wayne was very evil ledd,
 When such an one had guiding of the way.”

Observe that subtle touch of truth in the “wearing” of the portesse, indicating the abuse of books by idle readers, so thoroughly characteristic of unwilling studentship from the schoolboy upwards.

§ XCII. *Seventh side.* Vanity. She is smiling complacently as she looks into a mirror in her lap. Her robe is embroidered with roses, and roses form her crown. Undecipherable.

There is some confusion in the expression of this vice, between pride in the personal appearance and lightness of purpose. The word Vanitas generally, I think, bears, in the mediæval period, the sense given it in Scripture. “Let not him that is deceived trust in Vanity, for Vanity shall be his recompense.” “Vanity of Vanities.” “The Lord knoweth the thoughts of the wise, that they are vain.” It is difficult to find this sin,—which, after Pride, is the most universal, perhaps the most fatal, of all, fretting the whole depth of our humanity into storm “to waft a feather or to drown a fly,”—definitely expressed in art. Even Spenser, I think, has only partially expressed it under the figure of Phædria, more properly Idle Mirth, in the second book. The idea is, however, entirely worked out in the Vanity Fair of the “Pilgrim’s Progress.”

§ XCIII. *Eighth side.* Envy. One of the noblest pieces of expression in the series. She is pointing malignantly with her finger; a serpent is wreathed about her head like a cap,

another forms the girdle of her waist, and a dragon rests in her lap.

Giotto has, however, represented her, with still greater subtlety, as having her fingers terminating in claws, and raising her right hand with an expression partly of impotent regret, partly of involuntary grasping; a serpent, issuing from her mouth, is about to bite her between the eyes; she has long membranous ears, horns on her head, and flames consuming her body. The Envy of Spenser is only inferior to that of Giotto, because the idea of folly and quickness of hearing is not suggested by the size of the ear: in other respects it is even finer, joining the idea of fury, in the wolf on which he rides, with that of corruption on his lips, and of discoloration or distortion in the whole mind:

“ Malicious Envy rode
 Upon a ravenous wolfe, and still did chaw
 Between his cankred teeth a venomous tode,
 That all the poison ran about his jaw.
All in a kirtle of discolourd say
He clothed was, ypaynted full of eies,
 And in his bosome secretly there lay
 An hatefull snake, the which his taile uptyes
 In many folds, and mortall sting implies.”

He has developed the idea in more detail, and still more foathsomely, in the twelfth canto of the fifth book.

§ XCIV. ELEVENTH CAPITAL. Its decoration is composed of eight birds, arranged as shown in Plate V. of the “Seven Lamps,” which, however, was sketched from the Renaissance copy. These birds are all varied in form and action, but not so as to require special description.

§ XCV. TWELFTH CAPITAL. This has been very interesting, but is grievously defaced, four of its figures being entirely broken away, and the character of two others quite undecipherable. It is fortunate that it has been copied in the thirty-third capital of the Renaissance series, from which we are able to identify the lost figures.

First side. Misery. A man with a wan face, seemingly

pleading with a child who has its hands crossed on its breast. There is a buckle at his own breast in the shape of a cloven heart. Inscribed "MISERIA."

The intention of this figure is not altogether apparent, as it is by no means treated as a vice; the distress seeming real, and like that of a parent in poverty mourning over his child. Yet it seems placed here as in direct opposition to the virtue of Cheerfulness, which follows next in order; rather, however, I believe, with the intention of illustrating human life, than the character of the vice which, as we have seen, Dante placed in the circle of hell. The word in that case would, I think, have been "Tristitia," the "unholy Griefe" of Spenser—

"All in sable sorrowfully clad,
Downe hanging his dull head with heavy chere:

A pair of pincers in his hand he had,
With which he pinched people to the heart."

He has farther amplified the idea under another figure in the fifth canto of the fourth book:

"His name was Care; a blacksmith by his trade,
That neither day nor night from working spared;
But to small purpose yron wedges made:
Those be unquiet thoughts that carefull minds invade.
Rude was his garment, and to rags all rent,
Ne better had he, ne for better cared;
With blistered hands among the cinders brent."

It is to be noticed, however, that in the Renaissance copy this figure is stated to be, not *Miseria*, but "*Misericordia*." The contraction is a very moderate one, *Misericordia* being in old MS. written always as "*Mia*." If this reading be right, the figure is placed here rather as the companion, than the opposite, of Cheerfulness; unless, indeed, it is intended to unite the idea of Mercy and Compassion with that of Sacred Sorrow.

§ xcvi. *Second side*. Cheerfulness. A woman with long flowing hair, crowned with roses, playing on a tambourine, and with open lips, as singing. Inscribed "*ALACRITAS*."

We have already met with this virtue among those espe-

cially set by Spenser to attend on Womanhood. It is inscribed in the Renaissance copy, "ALACHRITAS CHANIT MECUM." Note the gutturals of the rich and fully developed Venetian dialect now affecting the Latin, which is free from them in the earlier capitals.

§ xcvii. *Third side.* Destroyed ; but, from the copy, we find it has been Stultitia, Folly ; and it is there represented simply as a man *riding*, a sculpture worth the consideration of the English residents who bring their horses to Venice. Giotto gives Stultitia a feather, cap, and club. In early manuscripts he is always eating with one hand, and striking with the other ; in later ones he has a cap and bells, or cap crested with a cock's head, whence the word "coxcorn."

§ xcvi. *Fourth side.* Destroyed, all but a book, which identifies it with the "Celestial Chastity" of the Renaissance copy ; there represented as a woman pointing to a book (connecting the convent life with the pursuit of literature ?).

Spenser's Chastity, Britomart, is the most exquisitely wrought of all his characters ; but, as before noticed, she is not the Chastity of the convent, but of wedded life.

§ xcix. *Fifth side.* Only a scroll is left ; but, from the copy, we find it has been Honesty or Truth. Inscribed "HONESTATEM DILIGO." It is very curious, that among all the Christian systems of the virtues which we have examined, we should find this one in Venice only.

The Truth of Spenser, Una, is, after Chastity, the most exquisite character in the "Faerie Queen."

§ c. *Sixth side.* Falsehood. An old woman leaning on a crutch ; and inscribed in the copy, "FALSITAS IN ME SEMPER EST." The Fidessa of Spenser, the great enemy of Una, or Truth, is far more subtly conceived, probably not without special reference to the Papal deceits. In her true form she is a loathsome hag, but in her outward aspect,

"A goodly lady, clad in scarlot red,
Purpled with gold and pearle ; . . .
Her wanton palfrey all was overspred
With tinsell trappings, woven like a wave,
Whose bridle rung with golden bells and bosses brave."

Dante's Fraud, Geryon, is the finest personification of all, but the description (*Inferno*, canto xvii.) is too long to be quoted.

§ CI. *Seventh side.* Injustice. An armed figure holding a halbert; so also in the copy. The figure used by Giotto with the particular intention of representing unjust government, is represented at the gate of an embattled castle in a forest, between rocks, while various deeds of violence are committed at his feet. Spenser's "Adicia" is a furious hag, at last transformed into a tiger.

Eighth side. A man with a dagger looking sorrowfully at a child, who turns its back to him. I cannot understand this figure. It is inscribed in the copy, "ASTINECIA (Abstinencia?) OPITIMA?"

§ CII. THIRTEENTH CAPITAL. It has lions' heads all round, coarsely cut.

FOURTEENTH CAPITAL. It has various animals, each sitting on its haunches. Three dogs, one a greyhound, one long-haired, one short-haired with bells about its neck; two monkeys, one with fan-shaped hair projecting on each side of its face; a noble boar, with its tusks, hoofs, and bristles sharply cut; and a lion and lioness.

§ CIII. FIFTEENTH CAPITAL. The pillar to which it belongs is thicker than the rest, as well as the one over it in the upper arcade.

The sculpture of this capital is also much coarser, and seems to me later than that of the rest; and it has no inscription, which is embarrassing, as its subjects have had much meaning; but I believe Selvatico is right in supposing it to have been intended for a general illustration of Idleness.

First side. A woman with a distaff; her girdle richly decorated, and fastened by a buckle.

Second side. A youth in a long mantle, with a rose in his hand.

Third side. A woman in a turban stroking a puppy which she holds by the haunches.

Fourth side. A man with a parrot.

Fifth side. A woman in a very rich costume, with braided

hair, and dress thrown into minute folds, holding a rosary (?) in her left hand, her right on her breast.

Sixth side. A man with a very thoughtful face, laying his hand upon the leaves of the capital.

Seventh side. A crowned lady, with a rose in her hand.

Eighth side. A boy with a ball in his left hand, and his right laid on his breast.

§ CIV. SIXTEENTH CAPITAL. It is decorated with eight large heads, partly intended to be grotesque,* and very coarse and bad, except only that in the sixth side, which is totally different from all the rest, and looks like a portrait. It is thin, thoughtful and dignified; thoroughly fine in every way. It wears a cap surmounted by two winged lions; and, therefore, I think Selvatico must have inaccurately written the list given in the note, for this head is certainly meant to express the superiority of the Venetian character over that of other nations. Nothing is more remarkable in all early sculpture, than its appreciation of the signs of dignity of character in the features, and the way in which it can exalt the principal figure in any subject by a few touches.

§ CV. SEVENTEENTH CAPITAL. This has been so destroyed by the sea wind, which sweeps at this point of the arcade round the angle of the palace, that its inscriptions are no longer legible, and great part of its figures are gone. Selvatico states them as follows: Solomon, the wise; Priscian, the grammarian; Aristotle, the logician; Tully, the orator; Pythagoras, the philosopher; Archimedes, the mechanic; Orpheus, the musician; Ptolemy the astronomer. The fragments actually remaining are the following:

First side. A figure with two books, in a robe richly decorated with circles of roses. Inscribed "SALOMON (SAP)IENS."

Second side. A man with one book, poring over it: he has had a long stick or reed in his hand. Of inscription only the letters "GRAMMATIC" remain.

* Selvatico states that these are intended to be representative of eight nations, Latins, Tartars, Turks, Hungarians, Greeks, Goths, Egyptians, and Persians. Either the inscriptions are now defaced or I have carelessly omitted to note them.

Third side. "ARISTOTLE:" so inscribed. He has a peaked double beard and a flat cap, from under which his long hair falls down his back.

Fourth side. Destroyed.

Fifth side. Destroyed, all but a board with three (counters?) on it.

Sixth side. A figure with compasses. Inscribed "GEOMET * *"

Seventh side. Nothing is left but a guitar with its handle wrought into a lion's head.

Eighth side. Destroyed.

§ CVI. We have now arrived at the EIGHTEENTH CAPITAL, the most interesting and beautiful of the palace. It represents the planets, and the sun and moon, in those divisions of the zodiac known to astrologers as their "houses;" and perhaps indicates, by the position in which they are placed, the period of the year at which this great corner-stone was laid. The inscriptions above have been in quaint Latin rhyme, but are now decipherable only in fragments, and that with the more difficulty because the rusty iron bar that binds the abacus has broken away, in its expansion, nearly all the upper portions of the stone, and with them the signs of contraction, which are of great importance. I shall give the fragments of them that I could decipher; first as the letters actually stand (putting those of which I am doubtful in brackets, with a note of interrogation), and then as I would read them.

§ CVII. It should be premised that, in modern astrology, the houses of the planets are thus arranged:

The house of the Sun,	is Leo.
“ Moon,	“ Cancer.
“ of Mars,	“ Aries and Scorpio.
“ Venus,	“ Taurus and Libra.
“ Mercury,	“ Gemini and Virgo.
“ Jupiter,	“ Sagittarius and Pisces.
“ Saturn,	“ Capricorn.
“ Herschel,	“ Aquarius.

The Herschel planet being of course unknown to the old astrologers, we have only the other six planetary powers, together with the sun ; and Aquarius is assigned to Saturn as his house. I could not find Capricorn at all ; but this sign may have been broken away, as the whole capital is grievously defaced. The eighth side of the capital, which the Herschel planet would now have occupied, bears a sculpture of the Creation of Man : it is the most conspicuous side, the one set diagonally across the angle ; or the eighth in our usual mode of reading the capitals, from which I shall not depart.

§ CVIII. *The first side*, then, or that towards the Sea, has Aquarius, as the house of Saturn, represented as a seated figure beautifully draped, pouring a stream of water out of an amphora over the leaves of the capital. His inscription is :

“ ET SATURNE DOMUS (ECLOCERUNT ?) 1^s 7BRE.”

§ CIX. *Second side*. Jupiter, in his houses Sagittarius and Pisces, represented throned, with an upper dress disposed in radiating folds about his neck, and hanging down upon his breast, ornamented by small pendent trefoiled studs or bosses. He wears the drooping bonnet and long gloves ; but the folds about the neck, shot forth to express the rays of the star, are the most remarkable characteristic of the figure. He raises his sceptre in his left hand over Sagittarius, represented as the centaur Chiron ; and holds two thunnies in his right. Something rough, like a third fish, has been broken away below them ; the more easily because this part of the group is entirely undercut, and the two fish glitter in the light, relieved on the deep gloom below the leaves. The inscription is :

“ INDE JOVI’ * DONA PISES SIMUL ATQ^s CIRONA.”

Or,

“ Inde Jovis dona
Pisces simul atque Chirona.”

* The comma in these inscriptions stands for a small cuneiform mark, I believe of contraction, and the small ^s for a zigzag mark of the same kind. The dots or periods are similarly marked on the stone.

Domus is, I suppose, to be understood before Jovis : “Then the house of Jupiter gives (or governs?) the fishes and Chiron.”

§ cx. *Third side.* Mars, in his houses Aries and Scorpio. Represented as a very ugly knight in chain mail, seated sideways on the ram, whose horns are broken away, and having a large scorpion in his left hand, whose tail is broken also, to the infinite injury of the group, for it seems to have curled across to the angle leaf, and formed a bright line of light, like the fish in the hand of Jupiter. The knight carries a shield, on which fire and water are sculptured, and bears a banner upon his lance, with the word “DEFEROSUM,” which puzzled me for some time. It should be read, I believe, “De ferrosum ;” which would be good *Venetian Latin* for “I am of iron.”

§ cxI. *Fourth side.* The Sun, in his house Leo. Represented under the figure of Apollo, sitting on the Lion, with rays shooting from his head, and the world in his hand. The inscription :

“TU ES DOMU’ SOLIS (QUO*?) SIGNE LEONI.”

I believe the first phrase is, “Tunc est Domus solis ;” but there is a letter gone after the “quo,” and I have no idea what case of signum “signe” stands for.

§ cxII. *Fifth side.* Venus, in her houses Taurus and Libra. The most beautiful figure of the series. She sits upon the bull, who is deep in the dewlap, and better cut than most of the animals, holding a mirror in her right hand, and the scales in her left. Her breast is very nobly and tenderly indicated under the folds of her drapery, which is exquisitely studied in its fall. What is left of the inscription, runs :

“LIBRA CUMTAURO DOMUS * * * PURIOR AUR *.”

§ cxIII. *Sixth side.* Mercury, represented as wearing a pendent cap, and holding a book : he is supported by three children in reclining attitudes, representing his houses Gemini

and Virgo. But I cannot understand the inscription, though more than usually legible.

“OCCUPAT ERIGONE STIBONS GEMINUQ’ LACONE.”

§ cxiv. *Seventh side.* The Moon, in her house Cancer. This sculpture, which is turned towards the Piazzetta, is the most picturesque of the series. The moon is represented as a woman in a boat, upon the sea, who raises the crescent in her right hand, and with her left draws a crab out of the waves, up the boat’s side. The moon was, I believe, represented in Egyptian sculptures as in a boat; but I rather think the Venetian was not aware of this, and that he meant to express the peculiar sweetness of the moonlight at Venice, as seen across the lagoons. Whether this was intended by putting the planet in the boat, may be questionable, but assuredly the idea was meant to be conveyed by the dress of the figure. For all the draperies of the other figures on this capital, as well as on the rest of the façade, are disposed in severe but full folds, showing little of the forms beneath them; but the moon’s drapery *ripples* down to her feet, so as exactly to suggest the trembling of the moonlight on the waves. This beautiful idea is highly characteristic of the thoughtfulness of the early sculptors: five hundred men may be now found who could have cut the drapery, as such, far better, for one who would have disposed its folds with this intention. The inscription is:

“LUNE CANCER DOMU T. PBET IORBE SIGNORU.”

§ cxv. *Eighth side.* God creating Man. Represented as a throned figure, with a glory round the head, laying his left hand on the head of a naked youth, and sustaining him with his right hand. The inscription puzzled me for a long time; but except the lost r and m of “formavit,” and a letter quite undefaced, but to me unintelligible, before the word Eva, in the shape of a figure of 7, I have safely ascertained the rest.

“DELIMO DSADA DECO STAFO ** AVIT7EVA.”

Or

“De limo Dominus Adam, de costa fo(r)m avit Evam;”

From the dust the Lord made Adam, and from the rib Eve.

I imagine the whole of this capital, therefore—the principal one of the old palace,—to have been intended to signify, first, the formation of the planets for the service of man upon the earth ; secondly, the entire subjection of the fates and fortune of man to the will of God, as determined from the time when the earth and stars were made, and, in fact, written in the volume of the stars themselves.

Thus interpreted, the doctrines of judicial astrology were not only consistent with, but an aid to, the most spiritual and humble Christianity.

In the workmanship and grouping of its foliage, this capital is, on the whole, the finest I know in Europe. The sculptor has put his whole strength into it. I trust that it will appear among the other Venetian casts lately taken for the Crystal Palace ; but if not, I have myself cast all its figures, and two of its leaves, and I intend to give drawings of them on a large scale in my folio work.

§ CXVI. NINETEENTH CAPITAL. This is, of course, the second counting from the Sea, on the Piazzetta side of the palace, calling that of the Fig-tree angle the first.

It is the most important capital, as a piece of evidence in point of dates, in the whole palace. Great pains have been taken with it, and in some portion of the accompanying furniture or ornaments of each of its figures a small piece of colored marble has been inlaid, with peculiar significance : for the capital represents the *arts of sculpture and architecture* ; and the inlaying of the colored stones (which are far too small to be effective at a distance, and are found in this one capital only of the whole series) is merely an expression of the architect's feeling of the essential importance of this art of inlaying, and of the value of color generally in his own art.

§ CXVII. *First side.* "ST. SIMPLICIUS" : so inscribed. A figure working with a pointed chisel on a small oblong block of green serpentine, about four inches long by one wide, inlaid in the capital. The chisel is, of course, in the left hand, but the right is held up open, with the palm outwards.

Second side. A crowned figure, carving the image of a child on a small statue, with a ground of red marble. The

sculptured figure is highly finished, and is in type of head much like the Ham or Japheth at the Vine angle. Inscription effaced.

Third side. An old man, uncrowned, but with curling hair, at work on a small column, with its capital complete, and a little shaft of dark red marble, spotted with paler red. The capital is precisely of the form of that found in the palace of the Tiepolos and the other thirteenth century work of Venice. This one figure would be quite enough, without any other evidence whatever, to determine the date of this flank of the Ducal Palace as not later, at all events, than the first half of the fourteenth century. Its inscription is broken away, all but "DISIPULO."

Fourth side. A crowned figure; but the object on which it has been working is broken away, and all the inscription except "ST. E(N?)AS."

Fifth side. A man with a turban, and a sharp chisel, at work on a kind of panel or niche, the back of which is of red marble.

Sixth side. A crowned figure, with hammer and chisel, employed on a little range of windows of the fifth order, having roses set, instead of orbicular ornaments, between the spandrils, with a rich cornice, and a band of marble inserted above. This sculpture assures us of the date of the fifth order window, which it shows to have been universal in the early fourteenth century.

There are also five arches in the block on which the sculptor is working, marking the frequency of the number five in the window groups of the time.

Seventh side. A figure at work on a pilaster, with Lombardic thirteenth century capital (for account of the series of forms in Venetian capitals, see the final Appendix of the next volume), the shaft of dark red spotted marble.

Eighth side. A figure with a rich open crown, working on a delicate recumbent statue, the head of which is laid on a pillow covered with a rich chequer pattern; the whole supported on a block of dark red marble. Inscription broken away, all but "ST. SYM. (Symmachus?) TV * * ANVS." There

appear, therefore, altogether to have been five saints, two of them popes, if Simplicius is the pope of that name (three in front, two on the fourth and sixth sides), alternating with the three uncrowned workmen in the manual labor of sculpture. I did not, therefore, insult our present architects in saying above that they "ought to work in the mason's yard with their men." It would be difficult to find a more interesting expression of the devotional spirit in which all great work was undertaken at this time.

§ CXVIII. TWENTIETH CAPITAL. It is adorned with heads of animals, and is the finest of the whole series in the broad massiveness of its effect; so simply characteristic, indeed, of the grandeur of style in the entire building, that I chose it for the first Plate in my folio work. In spite of the sternness of its plan, however, it is wrought with great care in surface detail; and the ornamental value of the minute chasing obtained by the delicate plumage of the birds, and the clustered bees on the honey-comb in the bear's mouth, opposed to the strong simplicity of its general form, cannot be too much admired. There are also more grace, life, and variety in the sprays of foliage on each side of it, and under the heads, than in any other capital of the series, though the earliness of the workmanship is marked by considerable hardness and coldness in the larger heads. A Northern Gothic workman, better acquainted with bears and wolves than it was possible to become in St. Mark's Place, would have put far more life into these heads, but he could not have composed them more skilfully.

§ CXIX. *First side.* A lion with a stag's haunch in his mouth. Those readers who have the folio plate, should observe the peculiar way in which the ear is cut into the shape of a ring, jagged or furrowed on the edge; an archaic mode of treatment peculiar, in the Ducal Palace, to the lions' heads of the fourteenth century. The moment we reach the Renaissance work, the lions' ears are smooth. Inscribed simply, "LEO."

Second side. A wolf with a dead bird in his mouth, its body wonderfully true in expression of the passiveness of death. The feathers are each wrought with a central quill and radiating filaments. Inscribed "LUPUS."

Third side. A fox, not at all like one, with a dead cock in his mouth, its comb and pendent neck admirably designed so as to fall across the great angle leaf of the capital, its tail hanging down on the other side, its long straight feathers exquisitely cut. Inscribed “(VULP?)IS.”

Fourth side. Entirely broken away.

Fifth side. “APER.” Well tusked, with a head of maize in his mouth; at least I suppose it to be maize, though shaped like a pine-cone.

Sixth side. “CHANIS.” With a bone, very ill cut; and a bald-headed species of dog, with ugly flap ears.

Seventh side. “MUSCIPULUS.” With a rat (?) in his mouth.

Eighth side. “URSUS.” With a honeycomb, covered with large bees.

§ CXX. TWENTY-FIRST CAPITAL. Represents the principal inferior professions.

First side. An old man, with his brow deeply wrinkled, and very expressive features, beating in a kind of mortar with a hammer. Inscribed “LAPICIDA SUM.”

Second side. I believe, a goldsmith; he is striking a small flat bowl or patera, on a pointed anvil, with a light hammer. The inscription is gone.

Third side. A shoemaker with a shoe in his hand, and an instrument for cutting leather suspended beside him. Inscription undecipherable.

Fourth side. Much broken. A carpenter planing a beam resting on two horizontal logs. Inscribed “CARPENTARIUS SUM.”

Fifth side. A figure shovelling fruit into a tub; the latter very carefully carved from what appears to have been an excellent piece of cooperage. Two thin laths cross each other over the top of it. The inscription, now lost, was, according to Selvatico, “MENSURATOR”?

Sixth side. A man, with a large hoe, breaking the ground, which lies in irregular furrows and clods before him. Now undecipherable, but according to Selvatico, “AGRICHOLA.”

Seventh side. A man, in a pendent cap, writing on a large scroll which falls over his knee. Inscribed “NOTARIUS SUM.”

Eighth side. A man forging a sword, or scythe-blade: he

wears a large skull-cap; beats with a large hammer on a solid anvil; and is inscribed "FABER SUM."

§ CXXI. TWENTY-SECOND CAPITAL. The Ages of Man; and the influence of the planets on human life.

First side. The moon, governing infancy for four years, according to Selvatico. I have no note of this side, having, I suppose, been prevented from raising the ladder against it by some fruit-stall or other impediment in the regular course of my examination; and then forgotten to return to it.

Second side. A child with a tablet, and an alphabet inscribed on it. The legend above is

"MĒCUREU' DNT. PUERICIE PAÑ. X."

Or, "Mercurius dominatur pueritiæ per annos X." (Selvatico reads VII.) "Mercury governs boyhood for ten (or seven) years."

Third side. An older youth, with another tablet, but broken. Inscribed

"ADOLOSCENCIE * * * P. AN. VII."

Selvatico misses this side altogether, as I did the first, so that the lost planet is irrecoverable, as the inscription is now defaced. Note the o for e in adolescentia: so also we constantly find u for o; showing, together with much other incontestable evidence of the same kind, how full and deep the old pronunciation of Latin always remained, and how ridiculous our English mincing of the vowels would have sounded to a Roman ear.

Fourth side. A youth with a hawk on his fist.

"IUVENTUTI DNT SOL. P. AN. XIX."

The sun governs youth for nineteen years.

Fifth side. A man sitting, helmed, with a sword over his shoulder. Inscribed

"SENECTUTI DNT MARS. P. AN. XV."

Mars governs manhood for fifteen years.

Sixth side. A very graceful and serene figure, in the pendent cap, reading.

“ SENICIE DNT JUPITER, P. ANN. XII.”
Jupiter governs age for twelve years.

Seventh side. An old man in a skull-cap, praying.

“ DECREPITĒ DNT SATN UQ* ADMŌTĒ.” (Saturnus usque ad mortem.)
Saturn governs decrepitude until death.

Eighth side. The dead body lying on a mattress.

“ ULTIMA EST MORS PENA PECCATI.”
Last comes death, the penalty of sin.

§ CXXII. Shakspeare's Seven Ages are of course merely the expression of this early and well known system. He has deprived the dotage of its devotion; but I think wisely, as the Italian system would imply that devotion was, or should be, always delayed until dotage.

TWENTY-THIRD CAPITAL. I agree with Selvatico in thinking this has been restored. It is decorated with large and vulgar heads.

§ CXXIII. TWENTY-FOURTH CAPITAL. This belongs to the large shaft which sustains the great party wall of the Sala del Gran Consiglio. The shaft is thicker than the rest; but the capital, though ancient, is coarse and somewhat inferior in design to the others of the series. It represents the history of marriage: the lover first seeing his mistress at a window, then addressing her, bringing her presents; then the bridal, the birth and the death of a child. But I have not been able to examine these sculptures properly, because the pillar is encumbered by the railing which surrounds the two guns set before the Austrian guard-house.

§ CXXIV. TWENTY-FIFTH CAPITAL. We have here the employments of the months, with which we are already tolerably acquainted. There are, however, one or two varieties worth noticing in this series.

First side. March. Sitting triumphantly in a rich dress, as the beginning of the year.

Second side. April and May. April with a lamb : May with a feather fan in her hand.

Third side. June. Carrying cherries in a basket.

I did not give this series with the others in the previous chapter, because this representation of June is peculiarly Venetian. It is called "the month of cherries," mese delle ceriese, in the popular rhyme on the conspiracy of Tiepolo, quoted above, Vol. I.

The cherries principally grown near Venice are of a deep red color, and large, but not of high flavor, though refreshing. They are carved upon the pillar with great care, all their stalks undercut.

Fourth side. July and August. The first reaping ; the leaves of the straw being given, shooting out from the tubular stalk. August, opposite, beats (the grain ?) in a basket.

Fifth side. September. A woman standing in a wine-tub, and holding a branch of vine. Very beautiful.

Sixth side. October and November. I could not make out their occupation ; they seem to be roasting or boiling some root over a fire.

Seventh side. December. Killing pigs, as usual.

Eighth side. January warming his feet, and February frying fish. This last employment is again as characteristic of the Venetian winter as the cherries are of the Venetian summer.

The inscriptions are undecipherable, except a few letters here and there, and the words MARCIUS, APRILIS, and FEBRUARIUS.

This is the last of the capitals of the early palace ; the next, or twenty-sixth capital, is the first of those executed in the fifteenth century under Foscari ; and hence to the Judgment angle the traveller has nothing to do but to compare the base copies of the earlier work with their originals, or to observe the total want of invention in the Renaissance sculptor, wherever he has depended on his own resources. This, however, always with the exception of the twenty-seventh and of the last capital, which are both fine.

I shall merely enumerate the subjects and point out the

plagiarisms of these capitals, as they are not worth description.

§ CXXV. TWENTY-SIXTH CAPITAL. Copied from the fifteenth, merely changing the succession of the figures.

TWENTY-SEVENTH CAPITAL. I think it possible that this may be part of the old work displaced in joining the new palace with the old ; at all events, it is well designed, though a little coarse. It represents eight different kinds of fruit, each in a basket ; the characters well given, and groups well arranged, but without much care or finish. The names are inscribed above, though somewhat unnecessarily, and with certainly as much disrespect to the beholder's intelligence as the sculptor's art, namely, ZEREXIS, PIRI, CHUCUMERIS, PERSICI, ZUCHE, MOLONI, FICI, HUVA. Zerexis (cherries) and Zuche (gourds) both begin with the same letter, whether meant for z, s, or c I am not sure. The Zuche are the common gourds, divided into two protuberances, one larger than the other, like a bottle compressed near the neck ; and the Moloni are the long water-melons, which, roasted, form a staple food of the Venetians to this day.

§ CXXVI. TWENTY-EIGHTH CAPITAL. Copied from the seventh.

TWENTY-NINTH CAPITAL. Copied from the ninth.

THIRTIETH CAPITAL. Copied from the tenth. The "Accidia" is noticeable as having the inscription complete, "ACCIDIA ME STRINGIT ;" and the "Luxuria" for its utter want of expression, having a severe and calm face, a robe up to the neck, and her hand upon her breast. The inscription is also different : "LUXURIA SUM STERC^s (?) INFERI" (?).

THIRTY-FIRST CAPITAL. Copied from the eighth.

THIRTY-SECOND CAPITAL. Has no inscription, only fully robed figures laying their hands, without any meaning, on their own shoulders, heads, or chins, or on the leaves around them.

THIRTY-THIRD CAPITAL. Copied from the twelfth.

THIRTY-FOURTH CAPITAL. Copied from the eleventh.

THIRTY-FIFTH CAPITAL. Has children, with birds or fruit, pretty in features, and utterly inexpressive, like the cherubs of the eighteenth century.

§ CXXXVII. THIRTY-SIXTH CAPITAL. This is the last of the Piazzetta façade, the elaborate one under the Judgment angle. Its foliage is copied from the eighteenth at the opposite side, with an endeavor on the part of the Renaissance sculptor to refine upon it, by which he has merely lost some of its truth and force. This capital will, however, be always thought, at first, the most beautiful of the whole series : and indeed it is very noble ; its groups of figures most carefully studied, very graceful, and much more pleasing than those of the earlier work, though with less real power in them ; and its foliage is only inferior to that of the magnificent Fig-tree angle. It represents, on its front or first side, Justice enthroned, seated on two lions ; and on the seven other sides examples of acts of justice or good government, or figures of lawgivers, in the following order :

Second side. Aristotle, with two pupils, giving laws. Inscribed :

“ARISTOT * * CHE DIE LEGE.”
Aristotle who declares laws.

Third side. I have mislaid my note of this side : Selvatico and Lazari call it “Isidore” (?).*

Fourth side. Solon with his pupils. Inscribed :

“SAL.º UNO DEI SETE SAVI DI GRECIA CHE DIE LEGE.”
Solon, one of the seven sages of Greece, who declares laws.

Note, by the by, the pure Venetian dialect used in this capital, instead of the Latin in the more ancient ones. One of the seated pupils in this sculpture is remarkably beautiful in the sweep of his flowing drapery.

Fifth side. The chastity of Scipio. Inscribed :

“ISIPIONE A CHASTITA CH * * * E LA FIA (e la figlia ?) * * ARE.”

A soldier in a plumed bonnet presents a kneeling maiden to the seated Scipio, who turns thoughtfully away.

Sixth side. Numa Pompilius building churches.

“NUMA POMPILIO IMPERADOR EDIFICHADOR DI TEMPI E CHIESE.”

* Can they have mistaken the ISIPIONE of the fifth side for the word Isidore ?

Numa, in a kind of hat with a crown above it, directing a soldier in Roman armor (note this, as contrasted with the mail of the earlier capitals). They point to a tower of three stories filled with tracery.

Seventh side. Moses receiving the law. Inscribed :

“QUANDO MOSE RECEVE LA LEGE I SUL MONTE.”

Moses kneels on a rock, whence springs a beautifully fancied tree, with clusters of three berries in the centre of three leaves, sharp and quaint, like fine Northern Gothic. The half figure of the Deity comes out of the abacus, the arm meeting that of Moses, both at full stretch, with the stone tablets between.

Eighth side. Trajan doing justice to the Widow.

“TRAJANO IMPERADOR CHE FA JUSTITIA A LA VEDOVA.”

He is riding spiritedly, his mantle blown out behind: the widow kneeling before his horse.

§ CXXVIII. The reader will observe that this capital is of peculiar interest in its relation to the much disputed question of the character of the later government of Venice. It is the assertion by that government of its belief that Justice only could be the foundation of its stability; as these stones of Justice and Judgment are the foundation of its halls of council. And this profession of their faith may be interpreted in two ways. Most modern historians would call it, in common with the continual reference to the principles of justice in the political and judicial language of the period,* nothing more than a cloak for consummate violence and guilt; and it may easily be proved to have been so in myriads of instances. But in the main, I believe the expression of feeling to be genuine. I do not believe, of the majority of the leading Venetians of this period whose portraits have come down to us, that they were deliberately and everlastingly hypocrites. I see no hypocrisy in their countenances. Much capacity of it, much subtlety, much natural and acquired reserve; but no meanness.

* Compare the speech of the Doge Mocenigo, above,—“first justice, and then the interests of the state:” and see Vol. III. Chap. II. § LIX.

On the contrary, infinite grandeur, repose, courage, and the peculiar unity and tranquillity of expression which come of sincerity or *wholeness* of heart, and which it would take much demonstration to make me believe could by any possibility be seen on the countenance of an insincere man. I trust, therefore, that these Venetian nobles of the fifteenth century did, in the main, desire to do judgment and justice to all men ; but, as the whole system of morality had been by this time undermined by the teaching of the Romish Church, the idea of justice had become separated from that of truth, so that dissimulation in the interest of the state assumed the aspect of duty. We had, perhaps, better consider, with some carefulness, the mode in which our own government is carried on, and the occasional difference between parliamentary and private morality, before we judge mercilessly of the Venetians in this respect. The secrecy with which their political and criminal trials were conducted, appears to modern eyes like a confession of sinister intentions ; but may it not also be considered, and with more probability, as the result of an endeavor to do justice in an age of violence ?—the only means by which Law could establish its footing in the midst of feudalism. Might not Irish juries at this day justifiably desire to conduct their proceedings with some greater approximation to the judicial principles of the Council of Ten ? Finally, if we examine, with critical accuracy, the evidence on which our present impressions of Venetian government are founded, we shall discover, in the first place, that two-thirds of the traditions of its cruelties are romantic fables : in the second, that the crimes of which it can be proved to have been guilty, differ only from those committed by the other Italian powers in being done less wantonly, and under profounder conviction of their political expediency : and lastly, that the final degradation of the Venetian power appears owing not so much to the principles of its government, as to their being forgotten in the pursuit of pleasure.

§ cxxix. We have now examined the portions of the palace which contain the principal evidence of the feeling of its builders. The capitals of the upper arcade are exceedingly

various in their character ; their design is formed, as in the lower series, of eight leaves, thrown into volutes at the angles, and sustaining figures at the flanks ; but these figures have no inscriptions, and though evidently not without meaning, cannot be interpreted without more knowledge than I possess of ancient symbolism. Many of the capitals toward the Sea appear to have been restored, and to be rude copies of the ancient ones ; others, though apparently original, have been somewhat carelessly wrought ; but those of them, which are both genuine and carefully treated, are even finer in composition than any, except the eighteenth, in the lower arcade. The traveller in Venice ought to ascend into the corridor, and examine with great care the series of capitals which extend on the Piazzetta side from the Fig-tree angle to the pilaster which carries the party wall of the Sala del Gran Consiglio. As examples of graceful composition in massy capitals meant for hard service and distant effect, these are among the finest things I know in Gothic art ; and that above the fig-tree is remarkable for its sculptures of the four winds ; each on the side turned towards the wind represented. Levante, the east wind ; a figure with rays round its head, to show that it is always clear weather when that wind blows, raising the sun out of the sea : Hotro, the south wind ; crowned, holding the sun in its right hand : Ponente, the west wind ; plunging the sun into the sea : and Tramontana, the north wind ; looking up at the north star. This capital should be carefully examined, if for no other reason than to attach greater distinctness of idea to the magnificent verbiage of Milton :

“ Thwart of these, as fierce,
Forth rush the Levant and the Ponient winds,
Eurus, and Zephyr ; with their lateral noise,
Sirocco and Libecchio.”

I may also especially point out the bird feeding its three young ones on the seventh pillar on the Piazzetta side ; but there is no end to the fantasy of these sculptures ; and the traveller ought to observe them all carefully, until he comes to the great Pilaster or complicated pier which sustains the

party wall of the Sala del Consiglio ; that is to say, the forty-seventh capital of the whole series, counting from the pilaster of the Vine angle inclusive, as in the series of the lower arcade. The forty-eighth, forty-ninth, and fiftieth are bad work, but they are old ; the fifty-first is the first Renaissance capital of the upper arcade : the first new lion's head with smooth ears, cut in the time of Foscari, is over the fiftieth capital ; and that capital, with its shaft, stands on the apex of the eighth arch from the Sea, on the Piazzetta side, of which one spandril is masonry of the fourteenth and the other of the fifteenth century.

§ cxxx. The reader who is not able to examine the building on the spot may be surprised at the definiteness with which the point of junction is ascertainable ; but a glance at the lowest range of leaves in the opposite Plate (XX.) will enable him to judge of the grounds on which the above statement is made. Fig. 12 is a cluster of leaves from the capital of the Four Winds ; early work of the finest time. Fig. 13 is a leaf from the great Renaissance capital at the Judgment angle, worked in imitation of the older leafage. Fig. 14 is a leaf from one of the Renaissance capitals of the upper arcade, which are all worked in the natural manner of the period. It will be seen that it requires no great ingenuity to distinguish between such design as that of fig. 12 and that of fig. 14.

§ cxxxi. It is very possible that the reader may at first like fig. 14 the best. I shall endeavor, in the next chapter, to show why he should not ; but it must also be noted, that fig. 12 has lost, and fig. 14 gained, both largely, under the hands of the engraver. All the bluntness and coarseness of feeling in the workmanship of fig. 14 have disappeared on this small scale, and all the subtle refinements in the broad masses of fig. 12 have vanished. They could not, indeed, be rendered in line engraving, unless by the hand of Albert Durer ; and I have, therefore, abandoned, for the present, all endeavor to represent any more important mass of the early sculpture of the Ducal Palace : but I trust that, in a few months, casts of many portions will be within the reach of the inhabitants of

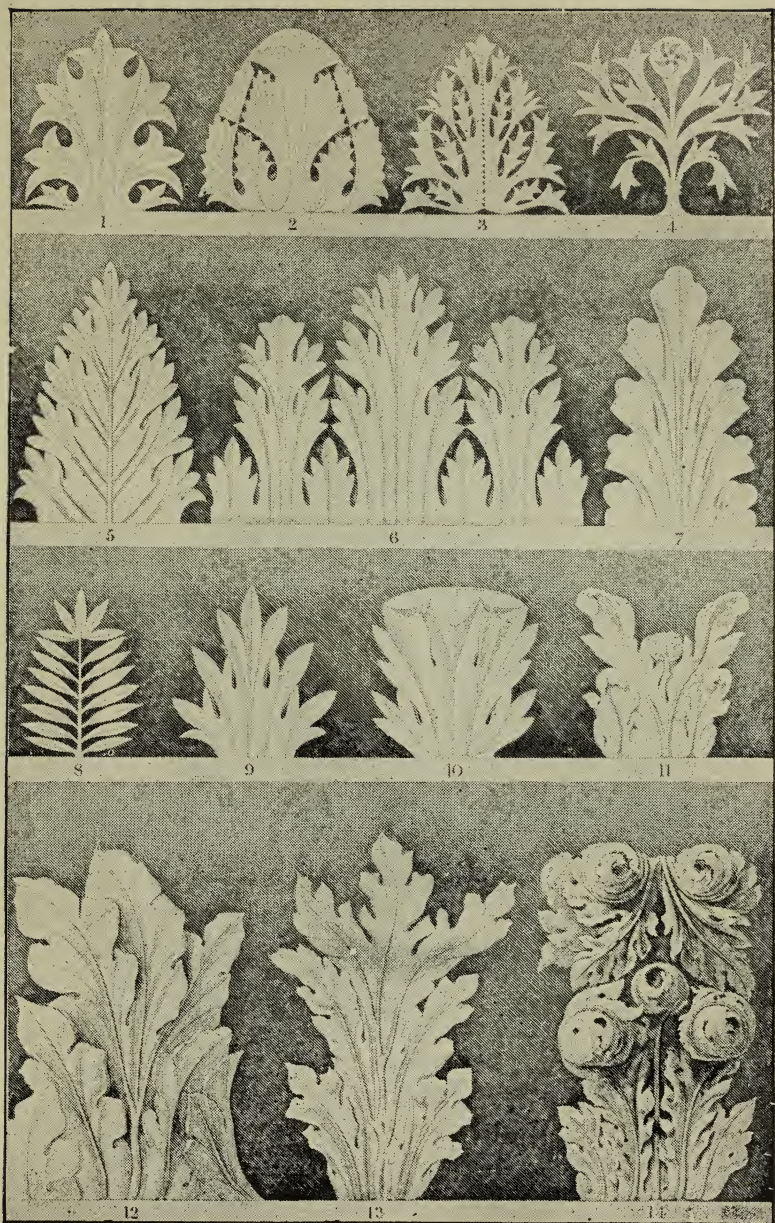

PLATE XX.—LEAFAGE OF THE VENETIAN CAPITALS.

London, and that they will be able to judge for themselves of their perfect, pure, unlabored naturalism ; the freshness, elasticity, and softness of their leafage, united with the most noble symmetry and severe reserve,—no running to waste, no loose or experimental lines, no extravagance, and no weakness. Their design is always sternly architectural ; there is none of the wildness or redundancy of natural vegetation, but there is all the strength, freedom, and tossing flow of the breathing leaves, and all the undulation of their surfaces, rippled, as they grew, by the summer winds, as the sands are by the sea.

§ cxxxii. This early sculpture of the Ducal Palace, then, represents the state of Gothic work in Venice at its central and proudest period, i. e. circa 1350. After this time, all is decline,—of what nature and by what steps, we shall inquire in the ensuing chapter ; for as this investigation, though still referring to Gothic architecture, introduces us to the first symptoms of the Renaissance influence, I have considered it as properly belonging to the third division of our subject.

§ cxxxiii. And as, under the shadow of these nodding leaves, we bid farewell to the great Gothic spirit, here also we may cease our examination of the details of the Ducal Palace ; for above its upper arcade there are only the four traceried windows,* and one or two of the third order on the Rio Façade, which can be depended upon as exhibiting the original workmanship of the older palace. I examined the capitals of the four other windows on the façade, and of those on the Piazzetta, one by one, with great care, and I found them all to be of far inferior workmanship to those which retain their traceries : I believe the stone framework of these windows must have been so cracked and injured by the flames of the great fire, as to render it necessary to replace it by new traceries ; and that the present mouldings and capitals are base imitations of the original ones. The traceries were at first, however, restored in their complete form, as the holes

* Some further details respecting these portions, as well as some necessary confirmations of my statements of dates, are, however, given in Appendix 1, Vol. III. I feared wearying the general reader by introducing them into the text.

for the bolts which fastened the bases of their shafts are still to be seen in the window-sills, as well as the marks of the inner mouldings on the soffits. How much the stone facing of the façade, the parapets, and the shafts and niches of the angles, retain of their original masonry, it is also impossible to determine; but there is nothing in the workmanship of any of them demanding especial notice; still less in the large central windows on each façade, which are entirely of Renaissance execution. All that is admirable in these portions of the building is the disposition of their various parts and masses, which is without doubt the same as in the original fabric, and calculated, when seen from a distance, to produce the same impression.

§ cxxxiv. Not so in the interior. All vestige of the earlier modes of decoration was here, of course, destroyed by the fires; and the severe and religious work of Guariento and Bellini has been replaced by the wildness of Tintoret and the luxury of Veronese. But in this case, though widely different in temper, the art of the renewal was at least intellectually as great as that which had perished: and though the halls of the Ducal Palace are no more representative of the character of the men by whom it was built, each of them is still a colossal casket of priceless treasure; a treasure whose safety has till now depended on its being despised, and which at this moment, and as I write, is piece by piece being destroyed for ever.

§ cxxxv. The reader will forgive my quitting our more immediate subject, in order briefly to explain the causes and the nature of this destruction; for the matter is simply the most important of all that can be brought under our present consideration respecting the state of art in Europe.

The fact is, that the greater number of persons or societies throughout Europe, whom wealth, or chance, or inheritance has put in possession of valuable pictures, do not know a good picture from a bad one,* and have no idea in what the

* Many persons, capable of quickly sympathizing with any excellence, when once pointed out to them, easily deceive themselves into the sup-

value of a picture really consists. The reputation of certain works is raised, partly by accident, partly by the just testimony of artists, partly by the various and generally bad taste of the public (no picture, that I know of, has ever, in modern times, attained popularity, in the full sense of the term, without having some exceedingly bad qualities mingled with its good ones), and when this reputation has once been completely established, it little matters to what state the picture may be reduced : few minds are so completely devoid of imagination as to be unable to invest it with the beauties which they have heard attributed to it.

§ cxxxvi. This being so, the pictures that are most valued are for the most part those by masters of established renown, which are highly or neatly finished, and of a size small enough to admit of their being placed in galleries or saloons, so as to be made subjects of ostentation, and to be easily seen by a crowd. For the support of the fame and value of such pictures, little more is necessary than that they should be kept bright, partly by cleaning, which is incipient destruction, and partly by what is called "restoring," that is, painting over, which is of course total destruction. Nearly all the gallery pictures in modern Europe have been more or less destroyed by one or other of these operations, generally exactly in proportion to the estimation in which they are held ; and as, originally, the smaller and more highly finished works of any great master are usually his worst, the contents of many of our most celebrated galleries are by this time, in reality, of very small value indeed.

§ cxxxvii. On the other hand, the most precious works of any noble painter are usually those which have been done quickly, and in the heat of the first thought, on a large scale, for places where there was little likelihood of their being well seen, or for patrons from whom there was little prospect of rich remuneration. In general, the best things are done in position that they are judges of art. There is only one real test of such power of judgment. Can they, at a glance, discover a good picture obscured by the filth, and confused among the rubbish, of the pawn-broker's or dealer's garret ?

this way, or else in the enthusiasm and pride of accomplishing some great purpose, such as painting a cathedral or a campo-santo from one end to the other, especially when the time has been short, and circumstances disadvantageous.

§ cxxxviii. Works thus executed are of course despised, on account of their quantity, as well as their frequent slightness, in the places where they exist; and they are too large to be portable, and too vast and comprehensive to be read on the spot, in the hasty temper of the present age. They are, therefore, almost universally neglected, whitewashed by custodes, shot at by soldiers, suffered to drop from the walls piecemeal in powder and rags by society in general; but, which is an advantage more than counterbalancing all this evil, they are not often "restored." What is left of them, however fragmentary, however ruinous, however obscured and defiled, is almost always *the real thing*; there are no fresh readings: and therefore the greatest treasures of art which Europe at this moment possesses are pieces of old plaster on ruinous brick walls, where the lizards burrow and bask, and which few other living creatures ever approach; and torn sheets of dim canvas, in waste corners of churches; and mildewed stains, in the shape of human figures, on the walls of dark chambers, which now and then an exploring traveller causes to be unlocked by their tottering custode, looks hastily round, and retreats from in a weary satisfaction at his accomplished duty.

§ cxxxix. Many of the pictures on the ceilings and walls of the Ducal Palace, by Paul Veronese and Tintoret, have been more or less reduced, by neglect, to this condition. Unfortunately they are not altogether without reputation, and their state has drawn the attention of the Venetian authorities and academicians. It constantly happens, that public bodies who will not pay five pounds to preserve a picture, will pay fifty to repaint it:* and when I was at Venice in 1846, there

* This is easily explained. There are, of course, in every place and at all periods, bad painters who conscientiously believe that they can improve every picture they touch; and these men are generally, in their presumption, the most influential over the innocence, whether of more

were two remedial operations carrying on, at one and the same time, in the two buildings which contain the pictures of greatest value in the city (as pieces of color, of greatest value in the world), curiously illustrative of this peculiarity in human nature. Buckets were set on the floor of the Scuola di San Rocco, in every shower, to catch the rain which came through the pictures of Tintoret on the ceiling; while in the Ducal Palace, those of Paul Veronese were themselves laid on the floor to be repainted; and I was myself present at the re-illumination of the breast of a white horse, with a brush, at the end of a stick five feet long, luxuriously dipped in a common house-painter's vessel of paint.

This was, of course, a large picture. The process has already been continued in an equally destructive, though somewhat more delicate manner, over the whole of the humbler canvases on the ceiling of the Sala del Gran Consiglio; and I heard it threatened when I was last in Venice (1851-2) to the "Paradise" at its extremity, which is yet in tolerable condition,—the largest work of Tintoret, and the most wonderful piece of pure, manly, and masterly oil-painting in the world.

§ cXL. I leave these facts to the consideration of the European patrons of art. Twenty years hence they will be acknowledged and regretted; at present, I am well aware, that it is of little use to bring them forward, except only to explain the present impossibility of stating what pictures *are*, and what *were*, in the interior of the Ducal Palace. I can only say, that in the winter of 1851, the "Paradise" of Tintoret was still comparatively uninjured, and that the Camera di Collegio, and its antechamber, and the Sala de' Pregadi were full of pictures by Veronese and Tintoret, that made their walls as precious as so many kingdoms; so precious indeed, and so full of majesty, that sometimes when walking at evening on the Lido, whence the great chain of the Alps, crested with silver clouds, might be seen rising above the

archs or municipalities. The carpenter and slater have little influence in recommending the repairs of the roof; but the bad painter has great influence, as well as interest, in recommending those of the picture.

front of the Ducal Palace, I used to feel as much awe in gazing on the building as on the hills, and could believe that God had done a greater work in breathing into the narrowness of dust the mighty spirits by whom its haughty walls had been raised, and its burning legends written, than in lifting the rocks of granite higher than the clouds of heaven, and veiling them with their various mantle of purple flower and shadowy pine.

APPENDIX.

1. THE GONDOLIER'S CRY.

MOST persons are now well acquainted with the general aspect of the Venetian gondola, but few have taken the pains to understand the cries of warning uttered by its boatmen, although those cries are peculiarly characteristic, and very impressive to a stranger, and have been even very sweetly introduced in poetry by Mr. Monckton Milnes. It may perhaps be interesting to the traveller in Venice to know the general method of management of the boat to which he owes so many happy hours.

A gondola is in general rowed only by one man, *standing* at the stern; those of the upper classes having two or more boatmen, for greater speed and magnificence. In order to raise the oar sufficiently, it rests, not on the side of the boat, but on a piece of crooked timber like the branch of a tree, rising about a foot from the boat's side, and called a "forcola." The forcola is of different forms, according to the size and uses of the boat, and it is always somewhat complicated in its parts and curvature, allowing the oar various kinds of rests and catches on both its sides, but perfectly free play in all cases; as the management of the boat depends on the gondolier's being able in an instant to place his oar in any position. The forcola is set on the right-hand side of the boat, some six feet from the stern: the gondolier stands on a little flat platform or deck behind it, and throws nearly the entire weight of his body upon the forward stroke. The effect of this stroke would be naturally to turn the boat's head round to the left, as well as to send it forward; but this tendency is corrected by keeping the blade of the oar under the water on the return

stroke, and raising it gradually, as a full spoon is raised out of any liquid, so that the blade emerges from the water only an instant before it again plunges. A *downward* and lateral pressure upon the forcola is thus obtained, which entirely counteracts the tendency given by the forward stroke; and the effort, after a little practice, becomes hardly conscious, though, as it adds some labor to the back stroke, rowing a gondola at speed is hard and breathless work, though it appears easy and graceful to the looker-on.

If then the gondola is to be turned to the left, the forward impulse is given without the return stroke; if it is to be turned to the right, the plunged oar is brought forcibly up to the surface; in either case a single strong stroke being enough to turn the light and flat-bottomed boat. But as it has no keel, when the turn is made sharply, as out of one canal into another very narrow one, the impetus of the boat in its former direction gives it an enormous lee-way, and it drifts laterally up against the wall of the canal, and that so forcibly, that if it has turned at speed, no gondolier can arrest the motion merely by strength or rapidity of stroke of oar; but it is checked by a strong thrust of the foot against the wall itself, the head of the boat being of course turned for the moment almost completely round to the opposite wall, and greater exertion made to give it, as quickly as possible, impulse in the new direction.

The boat being thus guided, the cry "Premi" is the order from one gondolier to another that he should "press" or thrust forward his oar, without the back stroke, so as to send the boat's head round *to the left*; and the cry "Stali" is the order that he should give the return or upward stroke which sends the boat's head round *to the right*. Hence, if two gondoliers meet under any circumstances which render it a matter of question on which side they should pass each other, the gondolier who has at the moment the least power over his boat, cries to the other, "Premi," if he wishes the boats to pass with their right-hand sides to each other, and "Stali," if with their left. Now, in turning a corner, there is of course risk of collision between boats coming from opposite sides,

and warning is always clearly and loudly given on approaching an angle of the canals. It is of course presumed that the boat which gives the warning will be nearer the turn than the one which receives and answers it; and therefore will not have so much time to check itself or alter its course. Hence the advantage of the turn, that is, the outside, which allows the fullest swing and greatest room for lee-way, is always yielded to the boat which gives warning. Therefore, if the warning boat is going to turn to the right, as it is to have the outside position, it will keep its own right-hand side to the boat which it meets, and the cry of warning is therefore "Premi," twice given; first as soon as it can be heard round the angle, prolonged and loud, with the accent on the e, and another strongly accented e added, a kind of question, "Pré-mi-é," followed at the instant of turning, with "Ah Premí," with the accent sharp on the final i. If, on the other hand, the warning boat is going to turn to the left, it will pass with its left-hand side to the one it meets; and the warning cry is, "Stáli-é, Ah Stalí." Hence the confused idea in the mind of the traveller that Stali means "to the left," and "Premi" to the right; while they mean, in reality, the direct reverse; the Stali, for instance, being the order to the unseen gondolier who may be behind the corner, coming from the left-hand side, that he should hold as much as possible *to his own right*; this being the only safe order for him, whether he is going to turn the corner himself, or to go straight on; for as the warning gondola will always swing right across the canal in turning, a collision with it is only to be avoided by keeping well within it, and close up to the corner which it turns.

There are several other cries necessary in the management of the gondola, but less frequently, so that the reader will hardly care for their interpretation; except only the "sciar," which is the order to the opposite gondolier to stop the boat as suddenly as possible by slipping his oar in front of the forcola. The cry is never heard except when the boatmen have got into some unexpected position, involving a risk of collision; but the action is seen constantly, when the gondola is rowed by two or more men (for if performed by the single

gondolier it only swings the boat's head sharp round to the right), in bringing up at a landing-place, especially when there is any intent of display, the boat being first urged to its full speed and then stopped with as much foam about the oar-blades as possible, the effect being much like that of stopping a horse at speed by pulling him on his haunches.

2. OUR LADY OF SALVATION.

"Santa Maria della Salute," Our Lady of Health, or of Safety, would be a more literal translation, yet not perhaps fully expressing the force of the Italian word in this case. The church was built between 1630 and 1680, in acknowledgment of the cessation of the plague;—of course to the Virgin, to whom the modern Italian has recourse in all his principal distresses, and who receives his gratitude for all principal deliverances.

The hasty traveller is usually enthusiastic in his admiration of this building; but there is a notable lesson to be derived from it, which is not often read. On the opposite side of the broad canal of the Giudecca is a small church, celebrated among Renaissance architects as of Palladian design, but which would hardly attract the notice of the general observer, unless on account of the pictures by John Bellini which it contains, in order to see which the traveller may perhaps remember having been taken across the Giudecca to the Church of the "Redentore." But he ought carefully to compare these two buildings with each other, the one built "to the Virgin," the other "to the Redeemer" (also a votive offering after the cessation of the plague of 1576); the one, the most conspicuous church in Venice, its dome, the principal one by which she is first discerned, rising out of the distant sea: the other, small and contemptible, on a suburban island, and only becoming an object of interest because it contains three small pictures! For in the relative magnitude and conspicuousness of these two buildings, we have an accurate index of the relative importance of the ideas of the Madonna and of Christ, in the modern Italian mind.

Some further account of this church is given in the final Index to the Venetian buildings at the close of the third Volume.

3. TIDES OF VENICE, AND MEASURES AT TORCELLO.

The lowest and highest tides take place in Venice at different periods, the lowest during the winter, the highest in the summer and autumn. During the period of the highest tides, the city is exceedingly beautiful, especially if, as is not unfrequently the case, the water rises high enough partially to flood St. Mark's Place. Nothing can be more lovely or fantastic than the scene, when the Campanile and the Golden Church are reflected in the calm water, and the lighter gondolas floating under the very porches of the façade. On the other hand, a winter residence in Venice is rendered peculiarly disagreeable by the low tides, which sometimes leave the smaller canals entirely dry, and large banks of mud beneath the houses, along the borders of even the Grand Canal. The difference between the levels of the highest and lowest tides I saw in Venice was 6 ft. 3 in. The average fall rise is from two to three feet.

The measures of Torcello were intended for Appendix 4 ; but having by a misprint referred the reader to Appendix 3, I give them here. The entire breadth of the church within the walls is 70 feet ; of which the square bases of the pillars, 3 feet on each side, occupy 6 feet ; and the nave, from base to base, measures 31 ft. 1 in. ; the aisles from base to wall, 16 feet odd inches, not accurately ascertainable on account of the modern wainscot fittings. The intervals between the bases of the pillars are 8 feet each, increasing toward the altar to 8 ft. 3 in., in order to allow for a corresponding diminution in the diameter of the bases from 3 ft. to 2 ft. 11 in. or 2 ft. 10. in. This subtle diminution of the bases is in order to prevent the eye from feeling the greater narrowness of the shafts in that part of the nave, their average circumference being 6 ft. 10 in. ;

and one, the second on the north side, reaching 7 feet, while those at the upper end of the nave vary from 6 ft. 8 in. to 6 ft. 4 in. It is probable that this diminution in the more distant pillars adds slightly to the perspective effect of length in the body of the church, as it is seen from the great entrance : but whether this was the intention or not, the delicate adaptation of this diminished base to the diminished shaft is a piece of fastidiousness in proportion which I rejoice in having detected ; and this the more, because the rude contours of the bases themselves would little induce the spectator to anticipate any such refinement.

4. DATE OF THE DUOMO OF TORCELLO.

The first flight to the lagoons for shelter was caused by the invasion of Attila in the fifth century, so that in endeavoring to throw back the thought of the reader to the former solitude of the islands, I spoke of them as they must have appeared "1300 years ago." Altinum, however, was not finally destroyed till the Lombard invasion in 641, when the episcopal seat was removed to Torcello, and the inhabitants of the mainland city, giving up all hope of returning to their former homes, built their Duomo there. It is a disputed point among Venetian antiquarians, whether the present church be that which was built in the seventh century, partially restored in 1008, or whether the words of Sagornino, "*ecclesiam jam vestustate consumptam recreare,*" justify them in assuming an entire rebuilding of the fabric. I quite agree with the Marchese Selvatico, in believing the present church to be the earlier building, variously strengthened, refitted, and modified by subsequent care ; but, in all its main features, preserving its original aspect, except, perhaps, in the case of the pulpit and chancel screen, which, if the Chevalier Bunsen's conclusions respecting early pulpits in the Roman basilicas be correct (see the next article of this Appendix), may possibly have been placed in their present position in the tenth century, and the fragmentary character of the workmanship of the latter, noticed in §§ x. and xi., would in that case have been the result of innovation, rather than of haste. The question,

however, whether they are of the seventh or eleventh century, does not in the least affect our conclusions, drawn from the design of these portions of the church, respecting pulpits in general.

5. MODERN PULPITS.

There is no character of an ordinary modern English church which appears to me more to be regretted than the peculiar pompousness of the furniture of the pulpits, contrasted, as it generally is, with great meagreness and absence of color in the other portions of the church ; a pompousness, besides, altogether without grace or meaning, and dependent merely on certain applications of upholstery ; which, curiously enough, are always in worse taste than even those of our drawing-rooms. Nor do I understand how our congregations can endure the aspect of the wooden sounding-board attached only by one point of its circumference to an upright pillar behind the preacher ; and looking as if the weight of its enormous leverage must infallibly, before the sermon is concluded, tear it from its support, and bring it down upon the preacher's head. These errors in taste and feeling will however, I believe, be gradually amended as more Gothic churches are built ; but the question of the position of the pulpit presents a more disputable ground of discussion. I can perfectly sympathise with the feeling of those who wish the eastern extremity of the church to form a kind of holy place for the communion table ; nor have I often received a more painful impression than on seeing the preacher at the Scotch church in George Street, Portman Square, taking possession of a perfect apse ; and occupying therein, during the course of the service, very nearly the same position which the figure of Christ does in that of the Cathedral of Pisa. But I nevertheless believe that the Scotch congregation are perfectly right, and have restored the real arrangement of the primitive churches. The Chevalier Bunsen informed me very lately, that, in all the early basilicas he has examined, the lateral pulpits are of more recent date than the rest of the building ; that he knows of none placed in the position which they now occupy, both in

the basilicas and Gothic cathedrals, before the ninth century; and that there can be no doubt that the bishop always preached or exhorted, in the primitive times, from his throne in the centre of the apse, the altar being always set at the centre of the church, in the crossing of the transepts. His Excellency found by experiment in Santa Maria Maggiore, the largest of the Roman basilicas, that the voice could be heard more plainly from the centre of the apse than from any other spot in the whole church; and, if this be so, it will be another very important reason for the adoption of the Romanesque (or Norman) architecture in our churches, rather than of the Gothic. The reader will find some farther notice of this question in the concluding chapter of the third volume.

Before leaving this subject, however, I must be permitted to say one word to those members of the Scotch Church who are severe in their requirement of the nominal or apparent extemporization of all addresses delivered from the pulpit. Whether they do right in giving those among their ministers who *cannot* preach extempore, the additional and useless labor of committing their sermons to memory, may be a disputed question; but it can hardly be so, that the now not unfrequent habit of making a desk of the Bible, and reading the sermon stealthily, by slipping the sheets of it between the sacred leaves, so that the preacher consults his own notes *on pretence* of consulting the Scriptures, is a very unseemly consequence of their over-strictness.

6. APSE OF MURANO.

The following passage succeeded in the original text to § xv. of Chap. III. Finding it not likely to interest the general reader, I have placed it here, as it contains matter of some interest to architects.

“On this plinth, thus carefully studied in relations of magnitude, the shafts are set at the angles, as close to each other as possible, as seen in the ground-plan. These shafts are founded on pure Roman tradition; their bases have no spurs, and the shaft itself is tapered in a bold curve, according to the classical

model. But, in the adjustment of the bases to each other, we have a most curious instance of the first beginning of the Gothic principle of aggregation of shafts. They have a singularly archaic and simple profile, composed of a single cavetto and roll, which are circular, on a square plinth. Now when these bases are brought close to each other at the angles of the apse, their natural position would be as in fig. 3, Plate I., leaving an awkward fissure between the two square plinths. This offended the architect's eye; so he cut part of each of the bases away, and fitted them close to each other, as in fig. 5, Plate I., which is their actual position. As before this piece of rough harmonization the circular mouldings reached the sides of the squares, they were necessarily cut partly away in the course of the adjustment, and run into each other as in the figure, so as to give us one of the first Venetian instances of the continuous Gothic base.

“The shafts measure on the average 2 ft. 8½ in. in circumference, at the base, tapering so much that under the lowest fillet of their necks they measure only 2 feet round, though their height is only 5 ft. 6 in., losing thus eight inches of girth in five feet and a half of height. They are delicately curved all the way up; and are 2½ in. apart from each other where they are nearest, and about 5 in. at the necks of their capitals.”

7. EARLY VENETIAN DRESS.

Sansovino's account of the changes in the dress of the Venetians is brief, masterly, and full of interest; one or two passages are deserving of careful notice, especially the introductory sentence. “For the Venetians from their first origin, having made it their aim to be peaceful and religious, and to keep on an equality with one another, that equality might induce stability and concord (as disparity produces confusion and ruin), made their dress a matter of conscience, . . . ; and our ancestors, observant lovers of religion, upon which all their acts were founded, and desiring that their young men should direct themselves to virtue, the true soul of all human action, *and above all to peace*, invented a dress conformable to

their gravity, such, that in clothing themselves with it, they might clothe themselves also with modesty and honor. And because their mind was bent upon giving no offence to any one, and living quietly as far as might be permitted them, it seemed good to them to show to every one, even by external signs, this their endeavor, by wearing a long dress, which was in no wise convenient for persons of a quick temperament, or of eager and fierce spirits."

Respecting the color of the women's dress, it is noticeable that blue is called "Venetian color" by Cassiodorus, translated "turchino" by Filiasi, vol. v. chap. iv. It was a very pale blue, as the place in which the word occurs is the description by Cassiodorus of the darkness which came over the sun's disk at the time of the Belisarian wars and desolation of the Gothic kingdom.

8. INSCRIPTIONS AT MURANO.

There are two other inscriptions on the border of the concha; but these, being written on the soffit of the face arch, which, as before noticed, is supported by the last two shafts of the chancel, could not be read by the congregation, and only with difficulty by those immediately underneath them. One of them is in black, the other in red letters. The first:

"Mutat quod sumsit, quod sollat crimina tandit
Et quod sumpsit, vultus vestisq. refulsit."

The second:

"Discipuli testes, prophete certa videntes
Et cernunt purum, sibi credunt ese futurum."

I have found no notice of any of these inscriptions in any Italian account of the church of Murano, and have seldom seen even Monkish Latin less intelligible. There is no mistake in the letters, which are all large and clear; but wrong letters may have been introduced by ignorant restorers, as has often happened in St. Mark's.

9. SHAFTS OF ST. MARK.

The principal pillars which carry the nave and transepts, fourteen in number, are of white alabaster veined with grey and amber ; each of a single block, 15 ft. high, and 6 ft. 2 in. round at the base. I in vain endeavored to ascertain their probable value. Every sculptor whom I questioned on this subject told me there were no such pieces of alabaster in the market, and that they were to be considered as without price.

On the façade of the church alone are two great ranges of shafts, seventy-two in the lower range, and seventy-nine in the upper ; all of porphyry, alabaster, and verd-antique or fine marble ; the lower about 9 ft., the upper about 7 ft. high, and of various circumferences, from 4 ft. 6 in. to 2 ft. round.

There are now so many published engravings, and, far better than engravings, calotypes, of this façade, that I may point out one or two circumstances for the reader's consideration without giving any plate of it here. And first, we ought to note the relations of the shafts and wall, the latter being first sheeted with alabaster, and then the pillars set within two or three inches of it, forming such a grove of golden marble that the porches open before us as we enter the church like glades in a deep forest. The reader may perhaps at first question the propriety of placing the wall so close behind the shafts that the latter have nearly as little work to do as the statues in a Gothic porch ; but the philosophy of this arrangement is briefly deducible from the principles stated in the text. The builder had at his disposal shafts of a certain size only, not fit to sustain the whole weight of the fabric above. He therefore turns just as much of the wall veil into shaft as he has strength of marble at his disposal, and leaves the rest in its massive form. And that there may be no dishonesty in this, nor any appearance in the shafts of doing more work than is really allotted to them, many are left visibly with half their capitals projecting beyond the archivolt they sustain, showing that the wall is very slightly dependent on their co-operation, and that many of them are little more than mere bonds or connecting rods between the foundation and cornices. If any architect

ventures to blame such an arrangement, let him look at our much vaunted early English piers in Salisbury Cathedral or Westminster Abbey, where the small satellitic shafts are introduced in the same gratuitous manner, but with far less excuse or reason : for those small shafts have nothing but their delicacy and purely theoretical connection with the archivolt mouldings to recommend them ; but the St. Mark's shafts have an intrinsic beauty and value of the highest order, and the object of the whole system of architecture, as above stated, is in great part to set forth the beauty and value of the shaft itself. Now, not only is this accomplished by withdrawing it occasionally from servile work, but the position here given to it, within three or four inches of a wall from which it nevertheless stands perfectly clear all the way up, is exactly that which must best display its color and quality. When there is much vacant space left behind a pillar, the shade against which it is relieved is comparatively indefinite, the eye passes by the shaft, and penetrates into the vacancy. But when a broad surface of wall is brought near the shaft, its own shadow is, in almost every effect of sunshine, so sharp and dark as to throw out its colors with the highest possible brilliancy ; if there be no sunshine, the wall veil is subdued and varied by the most subtle gradations of delicate half shadow, hardly less advantageous to the shaft which it relieves. And, as far as regards pure effect in open air (all artifice of excessive darkness or mystery being excluded), I do not know anything whatsoever in the whole compass of the European architecture I have seen, which can for a moment be compared with the quaint shade and delicate color, like that of Rembrandt and Paul Veronese united, which the sun brings out, as his rays move from porch to porch along the St. Mark's façade.

And, as if to prove that this was indeed the builder's intention, and that he did not leave his shafts idle merely because he did not know how to set them to work safely, there are two pieces of masonry at the extremities of the façade, which are just as remarkable for their frank trust in the bearing power of the shafts as the rest are for their want of confidence in them. But, before we come to these, we must say a word

or two respecting the second point named above, the superior position of the shafts.

It was assuredly not in the builder's power, even had he been so inclined, to obtain shafts high enough to sustain the whole external gallery, as it is sustained in the nave, on one arcade. He had, as above noticed, a supply of shafts of every sort and size, from which he chose the largest for his nave shafts ; the smallest were set aside for windows, jambs, balustrades, supports of pulpits, niches, and such other services, every conceivable size occurring in different portions of the building ; and the middle-sized shafts were sorted into two classes, of which on the average one was about two-thirds the length of the other, and out of these the two stories of the façade and sides of the church are composed, the smaller shafts of course uppermost, and more numerous than the lower, according to the ordinary laws of superimposition adopted by all the Romanesque builders, and observed also in a kind of architecture quite as beautiful as any we are likely to invent, that of forest trees.

Nothing is more singular than the way in which this kind of superimposition (the only right one in the case of shafts) will shock a professed architect. He has been accustomed to see, in the Renaissance designs, shaft put on the top of shaft, three or four times over, and he thinks this quite right ; but the moment he is shown a properly subdivided superimposition, in which the upper shafts diminish in size and multiply in number, so that the lower pillars would balance them safely even without cement, he exclaims that it is "against law," as if he had never seen a tree in his life.

Not that the idea of the Byzantine superimposition was taken from trees, any more than that of Gothic arches. Both are simple compliances with laws of nature, and, therefore, approximations to the forms of nature.

There is, however, one very essential difference between tree structure and the shaft structure in question ; namely, that the marble branches, having no vital connection with the stem, must be provided with a firm tablet or second foundation whereon to stand. This intermediate plinth or tablet

runs along the whole façade at one level, is about eighteen inches thick, and left with little decoration as being meant for hard service. The small porticos, already spoken of as the most graceful pieces of composition with which I am acquainted, are sustained on detached clusters of four or five columns, forming the continuation of those of the upper series, and each of these clusters is balanced on one grand detached shaft; as much trust being thus placed in the pillars here, as is withdrawn from them elsewhere. The northern portico has only one detached pillar at its outer angle, which sustains three shafts and a square pilaster; of these shafts the one at the outer angle of the group is the thickest (so as to balance the pilaster on the inner angle), measuring 3 ft. 2 in. round, while the others measure only 2 ft. 10 in. and 2 ft. 11 in.; and in order to make this increase of diameter, and the importance of the shaft, more manifest to the eye, the old builders made the shaft *shorter* as well as thicker, increasing the depth both of its capital and the base, with what is to the thoughtless spectator ridiculous incongruity, and to the observant one a most beautiful expression of constructive genius. Nor is this all. Observe: the whole strength of this angle depends on accuracy of *poise*, not on breadth or strength of foundation. It is a *balanced*, not a propped structure: if the balance fails, it must fall instantly; if the balance is maintained, no matter how the lower shaft is fastened into the ground, all will be safe. And to mark this more definitely, the great lower shaft *has a different base from all the others of the façade*, remarkably high in proportion to the shaft, on a circular instead of a square plinth, and *without spurs*, while all the other bases have spurs without exception. Glance back at what is said of the spurs at p. 80 of the first volume, and reflect that all expression of *grasp* in the foot of the pillar is here useless, and to be replaced by one of balance merely, and you will feel what the old builder wanted to say to us, and how much he desired us to follow him with our understanding as he laid stone above stone.

And this purpose of his is hinted to us once more, even by the position of this base in the ground plan of the foun-

dition of the portico ; for, though itself circular, it sustains a hexagonal plinth *set obliquely to the walls of the church*, as if expressly to mark to us that it did not matter how the base was set, so only that the weights were justly disposed above it.

10. PROPER SENSE OF THE WORD IDOLATRY.

I do not intend, in thus applying the word "Idolatry" to certain ceremonies of Romanist worship, to admit the propriety of the ordinary Protestant manner of regarding those ceremonies as distinctively idolatrous, and as separating the Romanist from the Protestant Church by a gulf across which we must not look to our fellow-Christians but with utter reprobation and disdain. The Church of Rome does indeed distinctively violate the *second* commandment ; but the true force and weight of the sin of idolatry are in the violation of the first, of which we are all of us guilty, in probably a very equal degree, considered only as members of this or that communion, and not as Christians or unbelievers. Idolatry is, both literally and verily, not the mere bowing down before sculptures, but the serving or becoming the slave of any images or imaginations which stand between us and God, and it is otherwise expressed in Scripture as "walking after the *Imagination*" of our own hearts. And observe also that while, at least on one occasion, we find in the Bible an indulgence granted to the mere external and literal violation of the second commandment, "When I bow myself in the house of Rimmon, the Lord pardon thy servant in this thing," we find no indulgence in any instance, or in the slightest degree, granted to "covetousness, which is idolatry" (Col. iii. 5 ; no casual association of terms, observe, but again energetically repeated in Ephesians, v. 5, "No covetous man, who is an idolater, hath any inheritance in the kingdom of Christ") ; nor any to that denial of God, idolatry in one of its most subtle forms, following so often on the possession of that wealth against which Agur prayed so earnestly, "Give me neither poverty nor

riches, lest I be full and deny thee, and say, 'Who is the Lord?'"

And in this sense, which of us is not an idolater? Which of us has the right, in the fulness of that better knowledge, in spite of which he nevertheless is not yet separated from the service of this world, to speak scornfully of any of his brethren, because, in a guiltless ignorance, they have been accustomed to bow their knees before a statue? Which of us shall say that there may not be a spiritual worship in their apparent idolatry, or that there is not a spiritual idolatry in our own apparent worship?

For indeed it is utterly impossible for one man to judge of the feeling with which another bows down before an image. From that pure reverence in which Sir Thomas Brown wrote, "I can dispense with my hat at the sight of a cross, but not with a thought of my Redeemer," to the worst superstition of the most ignorant Romanist, there is an infinite series of subtle transitions; and the point where simple reverence and the use of the image merely to render conception more vivid, and feeling more intense, change into definite idolatry by the attribution of Power to the image itself, is so difficultly determinable that we cannot be too cautious in asserting that such a change has actually taken place in the case of any individual. Even when it is definite and certain, we shall oftener find it the consequence of dulness of intellect than of real alienation of heart from God; and I have no manner of doubt that half of the poor and untaught Christians who are this day lying prostrate before crucifixes, Bambinos, and Volto Santos, are finding more acceptance with God, than many Protestants who idolize nothing but their own opinions or their own interests. I believe that those who have worshipped the thorns of Christ's crown will be found at last to have been holier and wiser than those who worship the thorns of the world's service, and that to adore the nails of the cross is a less sin than to adore the hammer of the workman.

But, on the other hand, though the idolatry of the lower orders in the Romish Church may thus be frequently excusable, the ordinary subterfuges by which it is defended are not

so. It may be extenuated, but cannot be denied ; and the attribution of power to the image,* in which it consists, is not merely a form of popular feeling, but a tenet of priestly instruction, and may be proved, over and over again, from any book of the Romish Church services. Take for instance the following prayer, which occurs continually at the close of the service of the Holy Cross :

“Sainte vraye Croye aourée,
 Qui du corps Dieu fu aournée
 Et de sa sueur arrousée,
 Et de son sanc enluminée,
 Par ta vertu, par ta puissance,
 Defent mon corps de meschance,
 Et monstroie moy par ton playsir
 Que vray confes puisse mourir.”

“Oh holy, true, and golden Cross, which wast adorned with God's body, and watered with His sweat, and illuminated with His blood, by thy healing virtue and thy power, defend my body from mischance ; and by thy good pleasure, let me make a good confession when I die.”

There can be no possible defence imagined for the mere terms in which this prayer and other such are couched : yet it is always to be remembered, that in many cases they are rather poetical effusions than serious prayers ; the utterances of imaginative enthusiasm, rather than of reasonable conviction ; and as such, they are rather to be condemned as illusory and fictitious, than as idolatrous, nor even as such, condemned altogether, for strong love and faith are often the roots of them and the errors of affection are better than the accuracies of apathy. But the unhappy results, among all religious sects, of the habit of allowing imaginative and poeti-

* I do not like to hear Protestants speaking with gross and uncharitable contempt even of the worship of relics. Elisha once trusted his own staff too far ; nor can I see any reasonable ground for the scorn, or the unkind rebuke, of those who have been taught from their youth upwards that to hope even in the hem of the garment may sometimes be better than to spend the living on physicians.

cal belief to take the place of deliberate, resolute, and prosaic belief, have been fully and admirably traced by the author of the "Natural History of Enthusiasm."

11. SITUATIONS OF BYZANTINE PALACES.

(1.) *The Terraced House.*

The most conspicuous pile in the midmost reach of the Grand Canal is the Casa Grimani, now the Post-Office. Letting his boat lie by the steps of this great palace, the traveller will see, on the other side of the canal, a building with a small terrace in front of it, and a little court with a door to the water, beside the terrace. Half of the house is visibly modern, and there is a great seam, like the edge of a scar, between it and the ancient remnant, in which the circular bands of the Byzantine arches will be instantly recognized. This building not having, as far as I know, any name except that of its present proprietor, I shall in future distinguish it simply as the Terraced House.

(2.) *Casa Businello.*

To the left of this edifice (looking from the Post-Office) there is a modern palace, on the other side of which the Byzantine mouldings appear again in the first and second stories of a house lately restored. It might be thought that the shafts and arches had been raised yesterday, the modern walls having been deftly adjusted to them, and all appearance of antiquity, together with the ornamentation and proportions of the fabric, having been entirely destroyed. I cannot, however, speak with unmixed sorrow of these changes, since, without his being implicated in the shame of them, they fitted this palace to become the residence of the kindest friend I had in Venice. It is generally known as the Casa Businello.

(3.) *The Braided House.*

Leaving the steps of the Casa Grimani, and turning the gondola away from the Rialto, we will pass the Casa Businello,

and the three houses which succeed it on the right. The fourth is another restored palace, white and conspicuous, but retaining of its ancient structure only the five windows in its second story, and an ornamental moulding above them which appears to be ancient, though it is inaccessible without scaffolding, and I cannot therefore answer for it. But the five central windows are very valuable; and as their capitals differ from most that we find (except in St. Mark's), in their plaited or braided border and basket-worked sides, I shall call this house, in future, the Braided House.*

(4.) *The Madonnetta House.*

On the other side of this palace is the Traghetto called "Della Madonnetta;" and beyond this Traghetto, still facing the Grand Canal, a small palace, of which the front shows mere vestiges of arcades, the old shafts only being visible, with obscure circular seams in the modern plaster which covers the arches. The side of it is a curious agglomeration of pointed and round windows in every possible position, and of nearly every date from the twelfth to the eighteenth century. It is the smallest of the buildings we have to examine, but by no means the least interesting: I shall call it, from the name of its Traghetto, the Madonnetta House.

(5.) *The Rio Foscari House.*

We must now descend the Grand Canal as far as the Palazzo Foscari, and enter the narrower canal, called the Rio di Ca' Foscari, at the side of that palace. Almost immediately after passing the great gateway of the Foscari courtyard, we shall see on our left, in the ruinous and time-stricken walls which totter over the water, the white curve of a circular arch covered with sculpture, and fragments of the bases of small pillars, entangled among festoons of the Erba della Madonna. I have already, in the folio plates which accompanied the first volume, partly illustrated this building. In what references I have to make to it here, I shall speak of it as the Rio Foscari House.

* Casa Tiepolo (?) in Lazari's Guide.

(6.) *Casa Farsetti.*

We have now to reascend the Grand Canal, and approach the Rialto. As soon as we have passed the Casa Grimani, the traveller will recognize, on his right, two rich and extensive masses of building, which form important objects in almost every picturesque view of the noble bridge. Of these, the first, that farthest from the Rialto, retains great part of its ancient materials in a dislocated form. It has been entirely modernized in its upper stories, but the ground floor and first floor have nearly all their original shafts and capitals, only they have been shifted hither and thither to give room for the introduction of various small apartments, and present, in consequence, marvellous anomalies in proportion. This building is known in Venice as the Casa Farsetti.

(7.) *Casa Loredan.*

The one next to it, though not conspicuous, and often passed with neglect, will, I believe, be felt at last, by all who examine it carefully, to be the most beautiful palace in the whole extent of the Grand Canal. It has been restored often, once in the Gothic, once in the Renaissance times,—some writers say, even rebuilt; but, if so, rebuilt in its old form. The Gothic additions harmonize exquisitely with its Byzantine work, and it is easy, as we examine its lovely central arcade, to forget the Renaissance additions which encumber it above. It is known as the Casa Loredan.

The eighth palace is the Fondaco de' Turchi, described in the text. A ninth existed, more interesting apparently than any of these, near the Church of San Moisè, but it was thrown down in the course of "improvements" a few years ago. A woodcut of it is given in M. Lazari's Guide.

12. MODERN PAINTING ON GLASS.

Of all the various principles of art which, in modern days, we have defied or forgotten, none are more indisputable, and few of more practical importance than this, which I shall have

occasion again and again to allege in support of many future deductions :

“All art, working with given materials, must propose to itself the objects which, with those materials, are most perfectly attainable ; and becomes illegitimate and debased if it propose to itself any other objects, better attainable with other materials.”

Thus, great slenderness, lightness, or intricacy of structure, —as in ramifications of trees, detached folds of drapery, or wreaths of hair,—is easily and perfectly expressible in metal-work or in painting, but only with great difficulty and imperfectly expressible in sculpture. All sculpture, therefore, which professes as its chief end the expression of such characters, is debased ; and if the suggestion of them be accidentally required of it, that suggestion is only to be given to an extent compatible with perfect ease of execution in the given material, not to the utmost possible extent. For instance : some of the most delightful drawings of our own water-color painter, Hunt, have been of birds' nests ; of which, in painting, it is perfectly possible to represent the intricate fibrous or mossy structure ; therefore, the effort is a legitimate one, and the art is well employed. But to carve a bird's nest out of marble would be physically impossible, and to reach any approximate expression of its structure would require prolonged and intolerable labor. Therefore, all sculpture which set itself to carving birds' nests as an end, or which, if a bird's nest were required of it, carved it to the utmost possible point of realization, would be debased. Nothing but the general form, and as much of the fibrous structure as could be with perfect ease represented, ought to be attempted at all.

But more than this. The workman has not done his duty, and is not working on safe principles, unless he even so far honors the materials with which he is working as to set himself to bring out their beauty, and to recommend and exalt, as far as he can, their peculiar qualities. If he is working in marble, he should insist upon and exhibit its transparency and solidity ; if in iron, its strength and tenacity ; if in gold, its ductility ; and he will invariably find the material grateful, and that his

work is all the nobler for being eulogistic of the substance of which it is made. But of all the arts, the working of glass is that in which we ought to keep these principles most vigorously in mind. For we owe it so much, and the possession of it is so great a blessing, that all our work in it should be completely and forcibly expressive of the peculiar characters which give it so vast a value.

These are two, namely, its DUCTILITY when heated, and TRANSPARENCY when cold, both nearly perfect. In its employment for vessels, we ought always to exhibit its ductility, and in its employment for windows, its transparency. All work in glass is bad which does not, with loud voice, proclaim one or other of these great qualities.

Consequently, *all cut glass* is barbarous: for the cutting conceals its ductility, and confuses it with crystal. Also, all very neat, finished, and perfect form in glass is barbarous: for this fails in proclaiming another of its great virtues; namely, the ease with which its light substance can be moulded or blown into any form, so long as perfect accuracy be not required. In metal, which, even when heated enough to be thoroughly malleable, retains yet such weight and consistency as render it susceptible of the finest handling and retention of the most delicate form, great precision of workmanship is admissible; but in glass, which when once softened must be blown or moulded, not hammered, and which is liable to lose, by contraction or subsidence, the fineness of the forms given to it, no delicate outlines are to be attempted, but only such fantastic and fickle grace as the mind of the workman can conceive and execute on the instant. The more wild, extravagant, and grotesque in their gracefulness the forms are, the better. No material is so adapted for giving full play to the imagination, but it must not be wrought with refinement or painfulness, still less with costliness. For as in gratitude we are to proclaim its virtues, so in all honesty we are to confess its imperfections; and while we triumphantly set forth its transparency, we are also frankly to admit its fragility, and therefore not to waste much time upon it, nor put any real art into it when intended for daily use. No workman ought ever

to spend more than an hour in the making of any glass vessel.

Next in the case of windows, the points which we have to insist upon are, the transparency of the glass and its susceptibility of the most brilliant colors ; and therefore the attempt to turn painted windows into pretty pictures is one of the most gross and ridiculous barbarisms of this pre-eminently barbarous century. It originated, I suppose, with the Germans, who seem for the present distinguished among European nations by the loss of the sense of color ; but it appears of late to have considerable chance of establishing itself in England : and it is a two-edged error, striking in two directions ; first at the healthy appreciation of painting, and then at the healthy appreciation of glass. Color, ground with oil, and laid on a solid opaque ground, furnishes to the human hand the most exquisite means of expression which the human sight and invention can find or require. By its two opposite qualities, each naturally and easily attainable, of transparency in shadow and opacity in light, it complies with the conditions of nature ; and by its perfect governableness it permits the utmost possible fulness and subtlety in the harmonies of color, as well as the utmost perfection in the drawing. Glass, considered as a material for a picture, is exactly as bad as oil paint is good. It sets out by reversing the conditions of nature, by making the lights transparent and the shadows opaque ; and the ungovernableness of its color (changing in the furnace), and its violence (being always on a high key, because produced by actual light), render it so disadvantageous in every way that the result of working in it for pictorial effect would infallibly be the destruction of all the appreciation of the noble qualities of pictorial color.

In the second place, this modern barbarism destroys the true appreciation of the qualities of glass. It denies, and endeavors as far as possible to conceal, the transparency, which is not only its great virtue in a merely utilitarian point of view, but its great spiritual character ; the character by which in church architecture it becomes most touchingly impressive, as typical of the entrance of the Holy Spirit into the heart of

man ; a typical expression rendered specific and intense by the purity and brilliancy of its sevenfold hues ; * and therefore in endeavoring to turn the window into a picture, we at once lose the sanctity and power of the noble material, and employ it to an end which is utterly impossible it should ever worthily attain. The true perfection of a painted window is to be serene, intense, brilliant, like flaming jewellery ; full of easily legible and quaint subjects, and exquisitely subtle, yet simple, in its harmonies. In a word, this perfection has been consummated in the designs, never to be surpassed, if ever again to be approached by human art, of the French windows of the twelfth and thirteenth centuries.

* I do not think that there is anything more necessary to the progress of European art in the present day than the complete understanding of this sanctity of Color. I had much pleasure in finding it, the other day, fully understood and thus sweetly expressed in a little volume of poems by a Miss Maynard :

“ For still in every land, though to Thy name
 Arose no temple,—still in every age,
 Though heedless man had quite forgot Thy praise,
 We praise Thee ; and at rise and set of sun
 Did we assemble duly, and intone
 A choral hymn that all the lands might hear.
 In heaven, on earth, and in the deep we praised Thee,
 Singly, or mingled in sweet sisterhood.
 But now, acknowledged ministrants, we come,
 Co-worshippers with man in this Thy house,
 We, the Seven Daughters of the Light, to praise
 Thee, Light of Light ! Thee, God of very God ! ”

A Dream of Fair Colors.

These poems seem to be otherwise remarkable for a very unobtrusive and pure religious feeling in subjects connected with art.



