

uditpratapsingh@gmail.com  
Mob No.- 09945510540

# Design Portfolio

By

Udit Pratap Singh



**Ladder of design never be end**

Electric cooking widely used in india to toast the bread. So my aim is to develop the concept for new range of toaster and also enable to make roti.....



## Product Environment



Toaster are widly used in urban areas



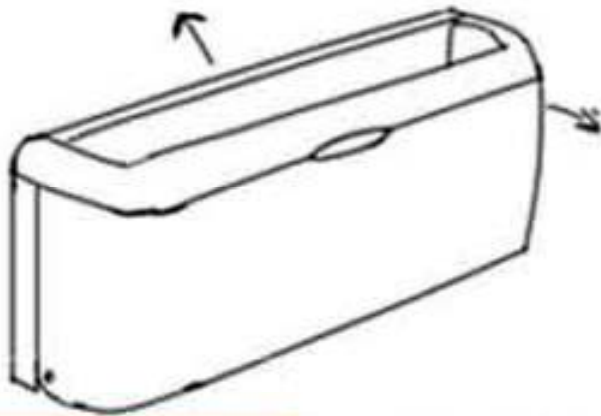

There can be a product which would aid customers to bake their toast as well as chapatis.

## Concepts

The idea was to make a collapsible toaster which could be open to get an electric pan and when folded it becomes toaster. Idea is to design the toaster as well as roti pan means two in one.....

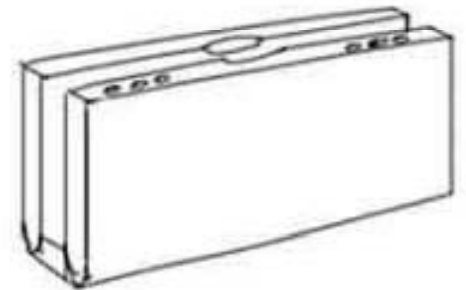
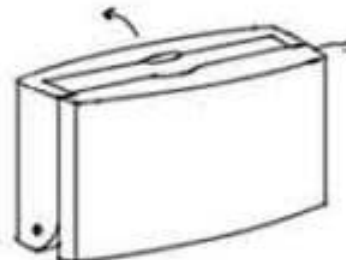

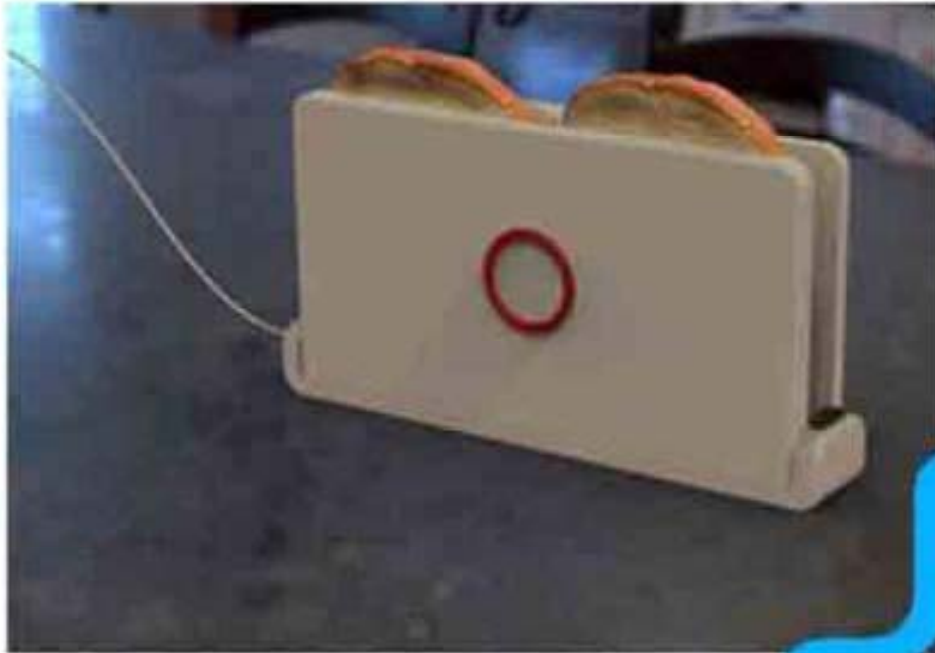

Fold to toast bread

## Toaster

Open the toaster to bake chapati.....



# Toaster

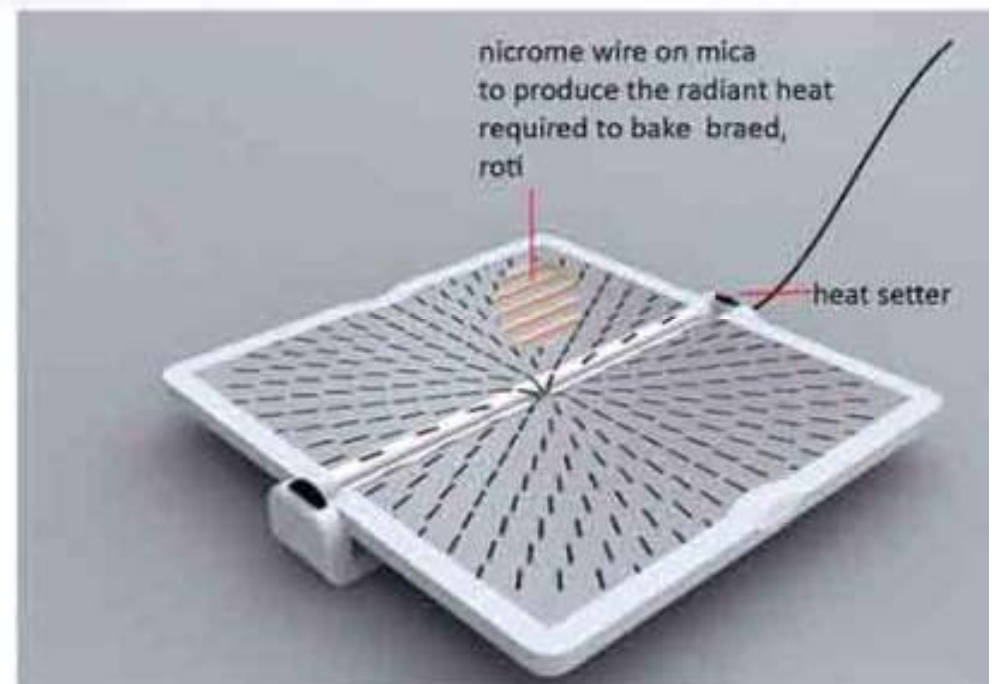
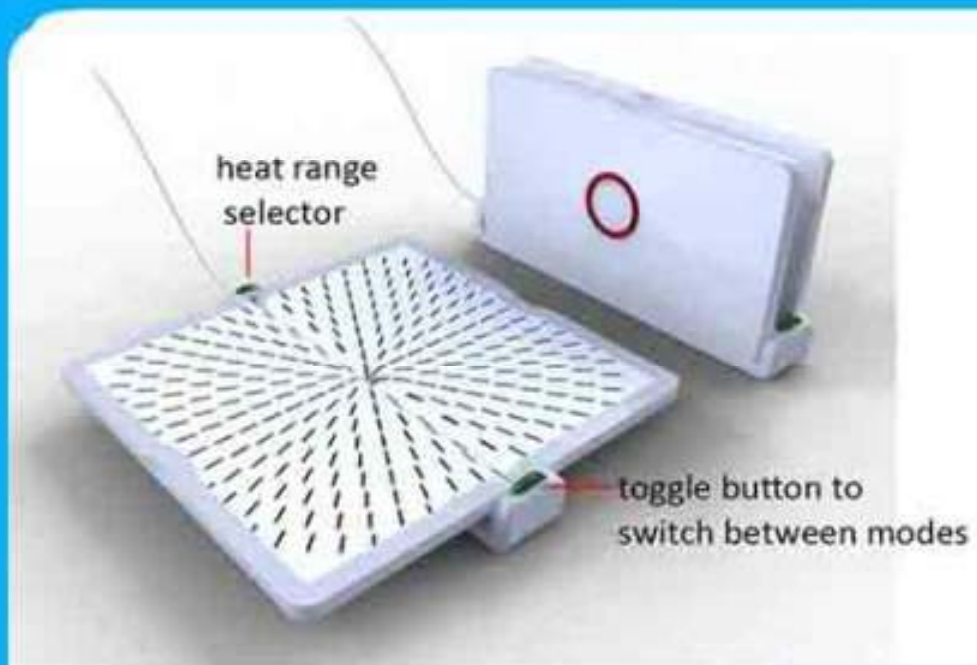

# Toaster

**Exploded View**

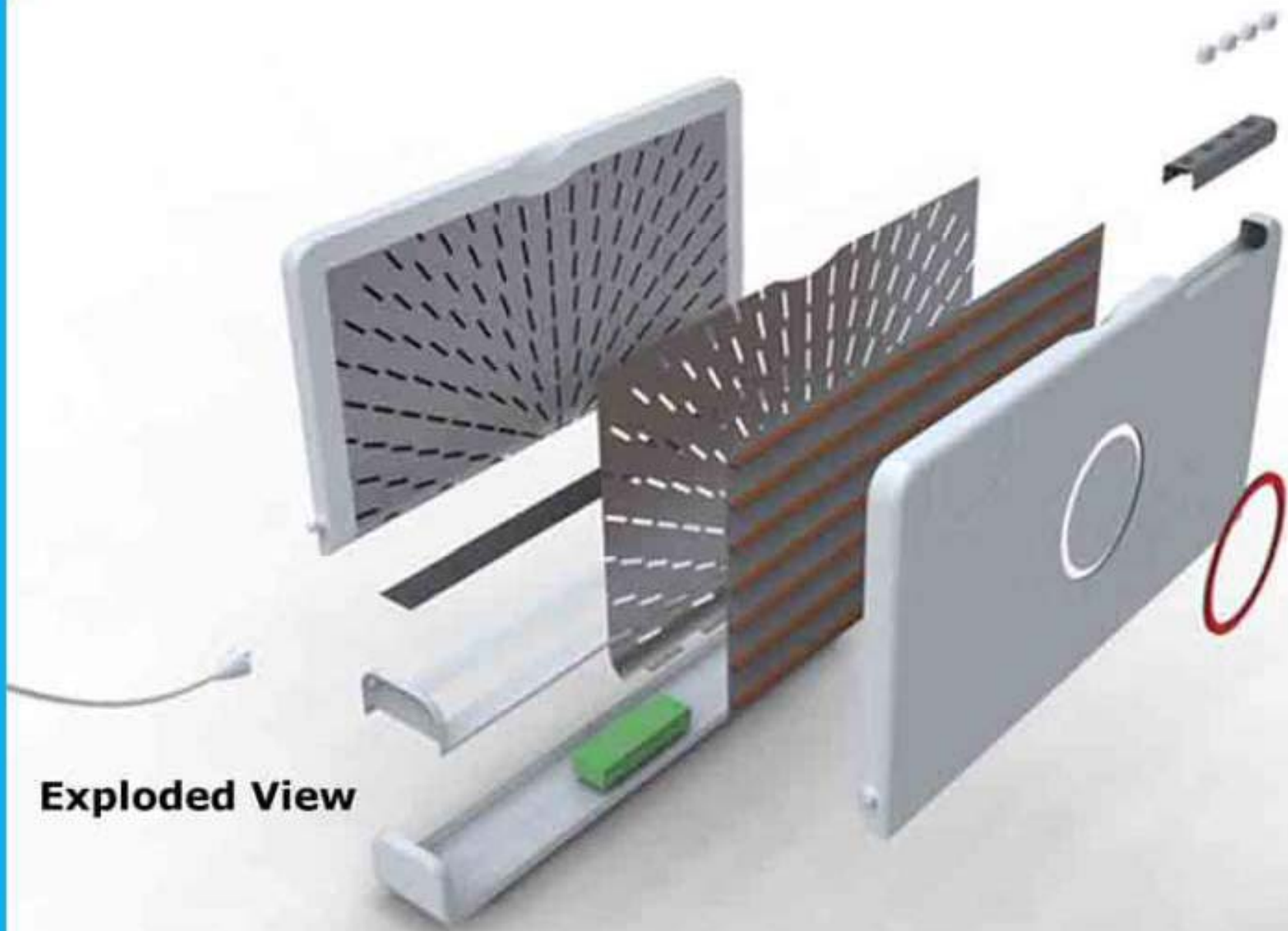

## Life style product

Waterjug inspired from the works of Ross Lovegrove and organic way of life water droplet evokes the feeling of purity & freshness



modelled in Alias  
Rendered in Hypershoot

## Redesign of hair dryer



Objective was to become conversant with the complete design process through the redesign of hair dryer . Project began with understanding the product. Dismantle study was done to understand the principles behind working of hair dryer . Different contexts of the user were innovated ,in which the product will be used by consumers in order to come up with entirely novel, more useful and effective product





## User contexts for hair dryer



### Tourists

It can be given along with soaps ,shampoos, towel and other accessories as a tourist kit to tourists by travel agency or by the hotel at which they stay



### Beauty kit

It can be given along with beauty kit for ladies



### Mass usage

It can be sold along with other accessories to salon as kit. Can be placed in bathrooms of gyms and swimming pools



### Medical proposes

It can be given as complement to medical shampoos, conditioners and hair care products



### Bathroom interiors

It can be given along with to bathroom accessories as set

## Hair dryer for tourists

Easy to use  
Comfortable  
Portable  
Safety



**Tools used:** Alias, Hyper Shot, Photoshop

# TORCH

Aim:- design a hand held torch considering the metaphor of any letter from any language.

Letter selected:- " Y".

This letter reflects the youth and feminism.  
It also helps to design a torch which is curvy and ergonomic.



# TORCH

**Curvy  
Ergonomic  
Stylish**

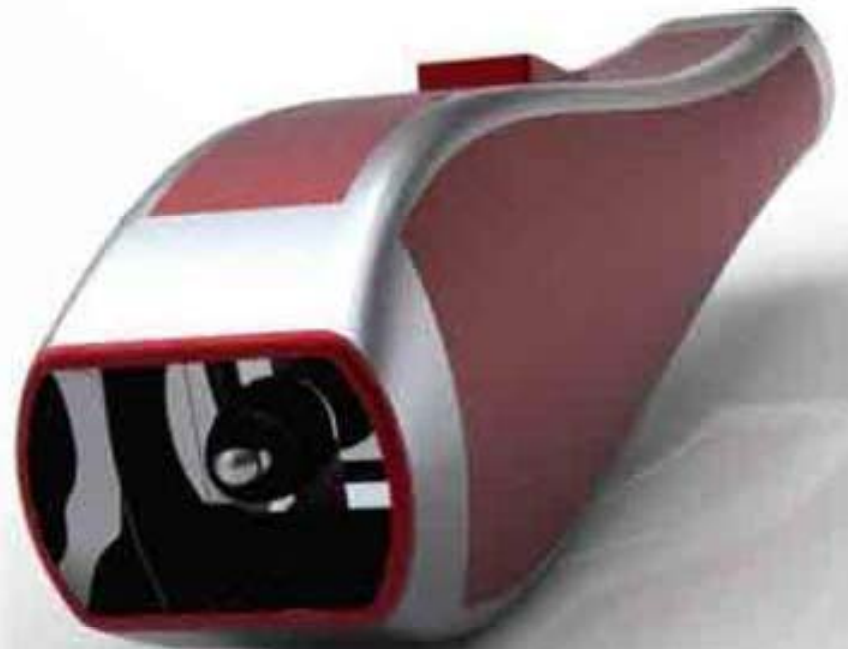

# FLOWER POT

Everybody loves to decorate their houses. People feel it very personal and it has some meaning to them.

Product:- Flower Pot.

Chosen Theme:- Bird's Nest.

Product Aspects:- Shape should be organic, simple and beautiful.



Organic Shape  
Personal Feeling



# Concepts of Car Stereo

Objective to create 3D model of car stereo, theme is given as any electronic gazette with the help of elements of design

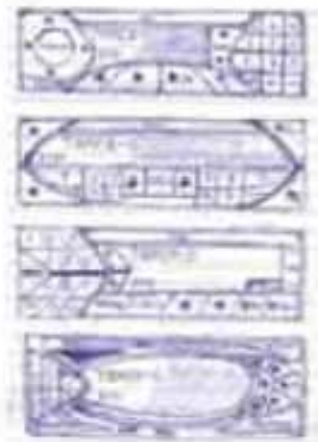
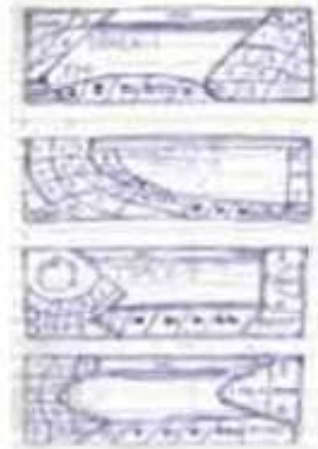

# Concepts of Car Stereo



Photoshop rendering of the concept car stereo



Concept I have taken from "Nero Show-Time" and It really futuristic and novelty.....





# Concepts of Car Stereo



Final Concepts

# Concept of Pen Drive

Objective to redesign of "Pen Drive" with aesthetic look, easy to handle. Task is find the problem in available pen drive and solve one of the problem. I've searched the problem of loose cap and I have drawn some concept to solve this type of problem.

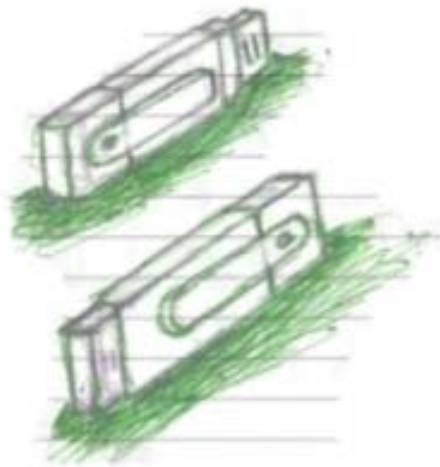
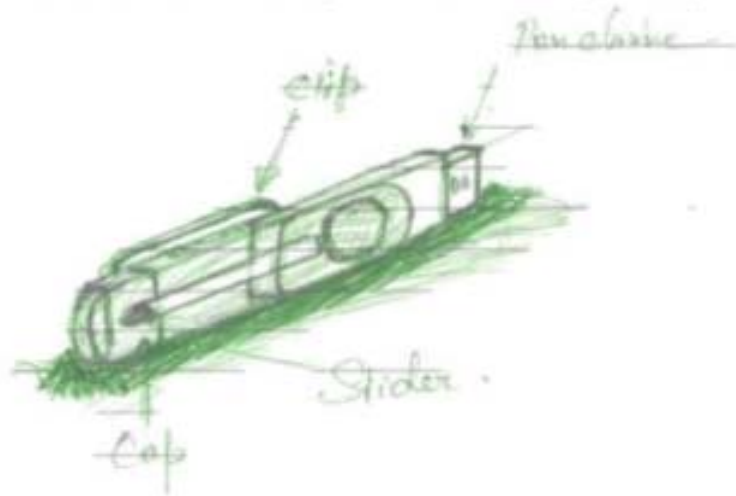

# Material Exploration

Design a useful product out of the dead CD's which is an e-waste

A ceiling lamp is designed out of the waste CD's 80 in number.  
This can be used as a lighting fixture in home or as a disco light in club.  
Materials used-Dead CD'S, Nylon Thread, Glass Bulb, & Adhesives



# Abstract of Flower

Reprerent the flower with minimum & simple elements



Pattern in nature  
Hexagonal shape is repeated

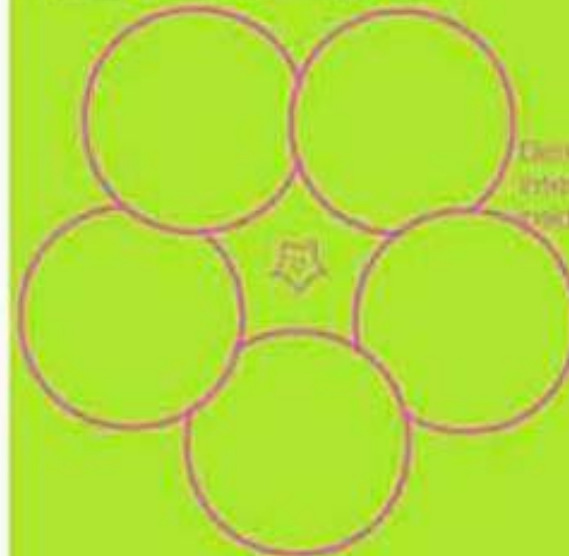

Elements used-circles & arc  
Intersection of circles gives  
into hexagonal shape

## Studies in forms



# Sketches



## Concept of Tipper Design



Design of the truck body is based on the standard body work. The body is made of heavy duty steel. The body is built in the form of a box. The body is made of heavy duty steel. The body is built in the form of a box. The body is made of heavy duty steel. The body is built in the form of a box.

**PROJECT REPORT  
ON  
Concept of Tipper cabinet styling  
&  
Front fascia of low floor city bus  
in**



INITIAL FORM EXPLORATION

DESIGN OBJECTIVE

The objective of the exercise is to evolve a truck (which is used in both rouged and smooth areas) based on the existing specifications of commercial vehicle platform

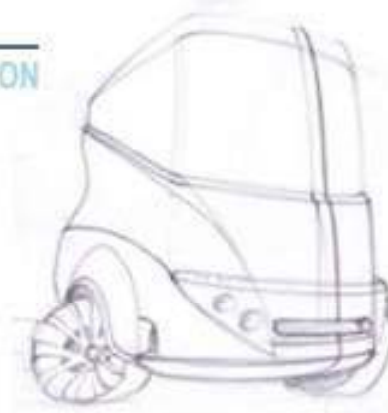

A brief study of International market trends will be done. The above study would lead to define the broad specification and design intervention required



The truck design should align to the international practices in design and style in the rough condition truck segment. The new truck design language would convey the affection in simplest possible manner. The objective is to evolve a new truck form

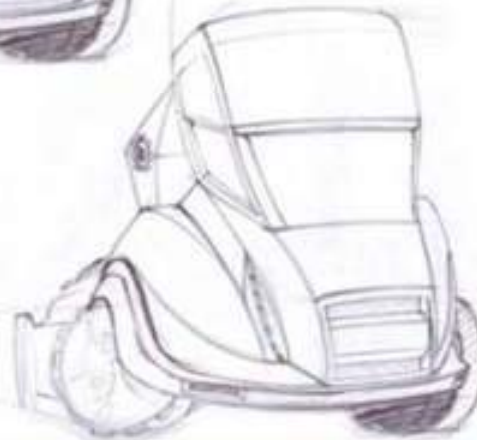



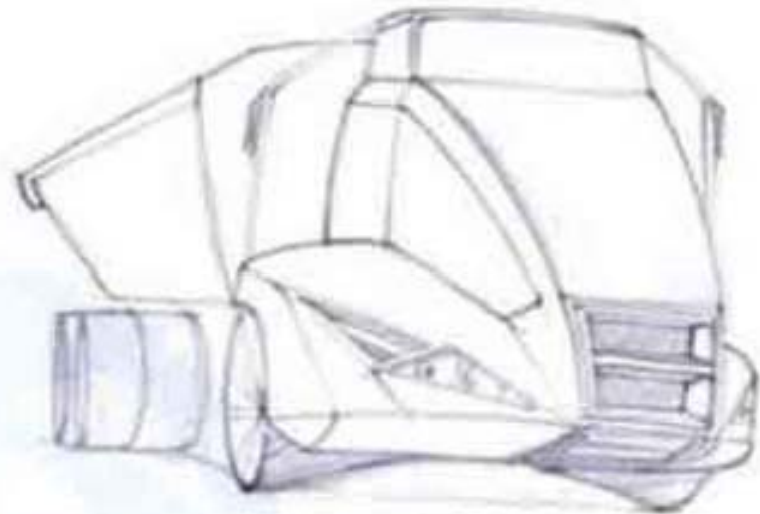

The truck design will be evolve keeping the basic structure and tubular steel with paneling on top. The front panel would be in composite with add on member like bumper, grill, etc would be in FRP molding in order to give the truck more feminine, sophisticated and futuristic look.

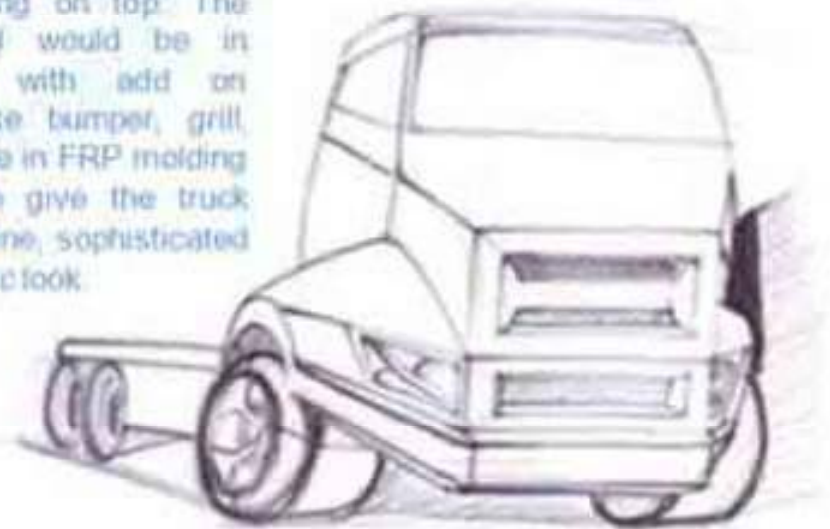
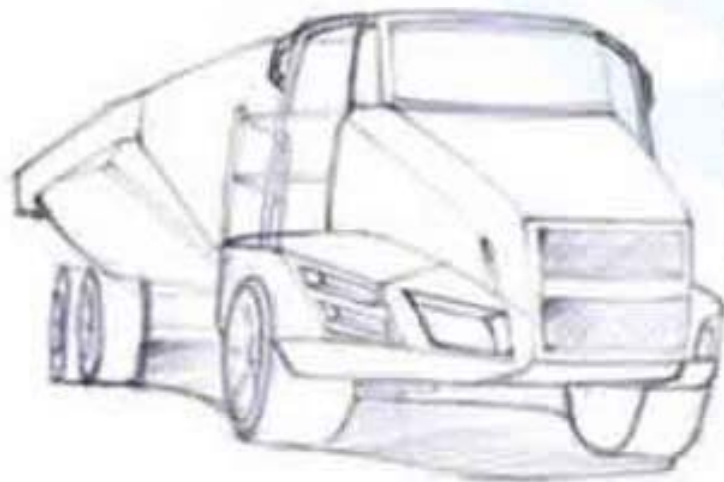

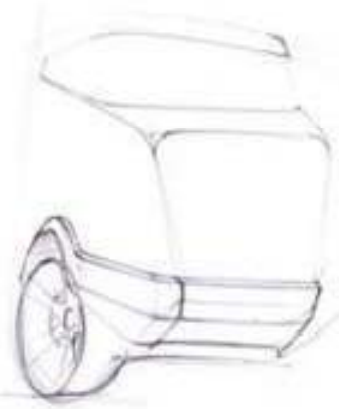
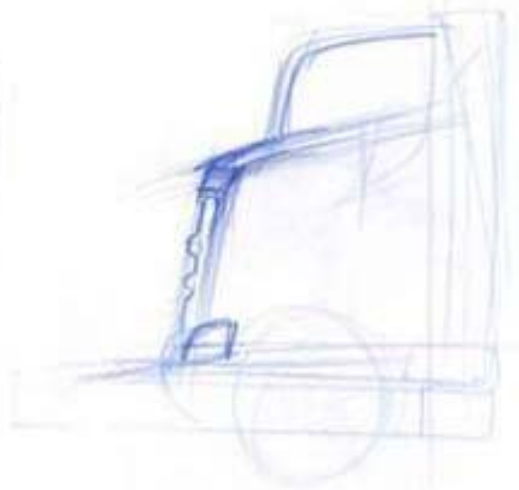
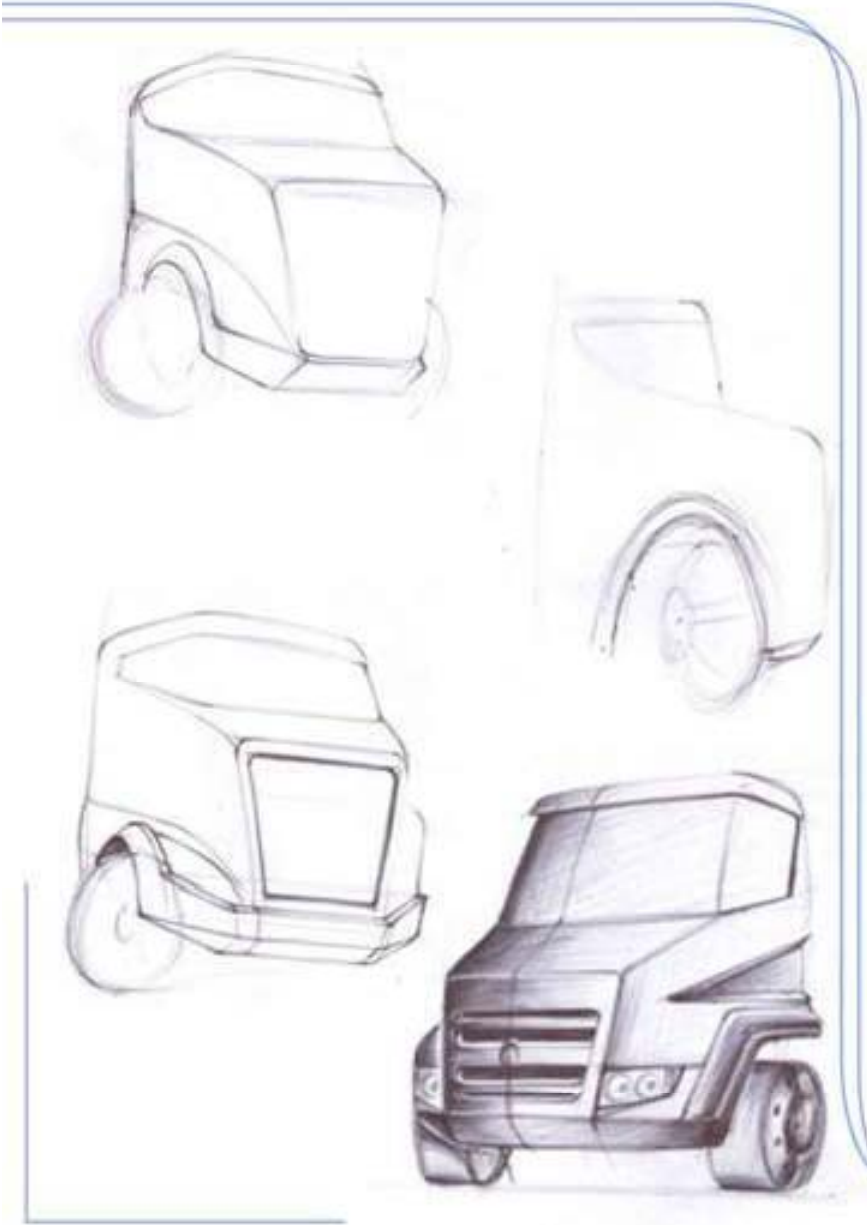

CONCEPT GENERATION FOR 'TRUCK FRONT'



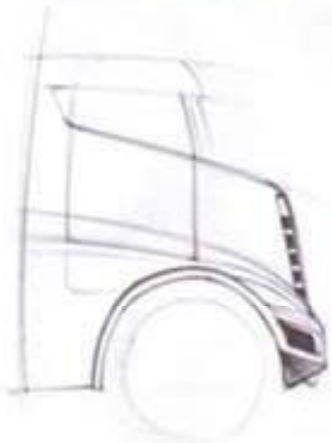
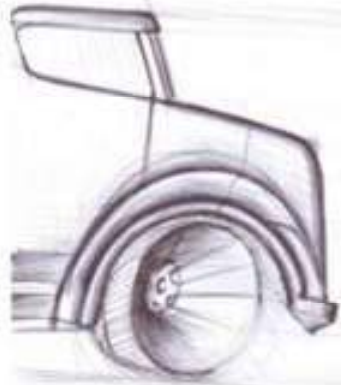



More playful features



## Design language for new concept

Simple design



Should be well balanced



New form should convey harmony in the design

FINAL CONCEPTS FOR TRUCK CABIN



FRONT, SIDE, TOP & PHOTOSHOP RENDERING OF THE TRUCK CABINET

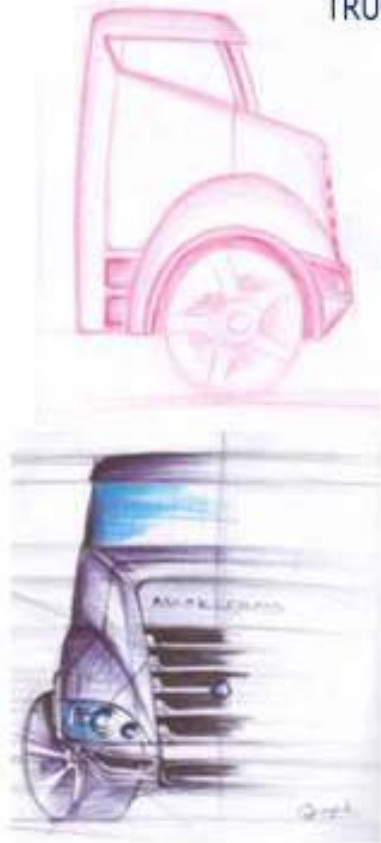



**FINAL CONCEPT RENDERING**



## FRONT FASCIA OF LOW FLOOR CITY BUS

### Design Objective

The objective of the exercise is to evolve a front fascia of low floor city bus (which is used in the city and the smooth areas) based on the existing specifications of commercial vehicle platform.

The front fascia of low floor design will be evolve keeping the basic structure bus.  
The front panel would be in composite with add on member like bumper, grill, etc would be in FRP molding in order to give the truck more feminine, sophisticated and futuristic look and Front grill should be incorporate the identity of the company.



### Concept Generation

Sketches for low floor city bus  
(Form exploration)

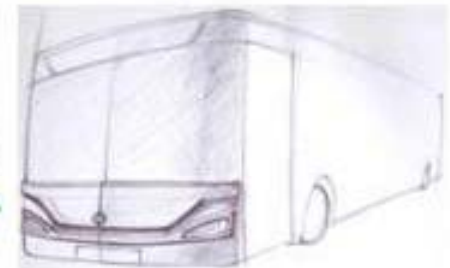
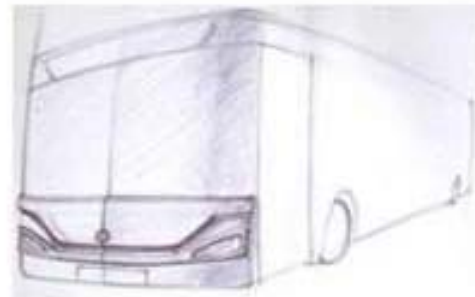
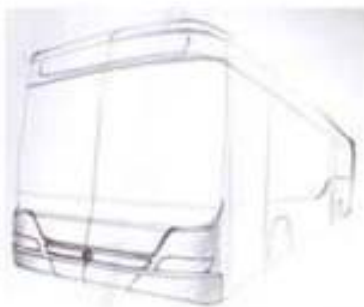



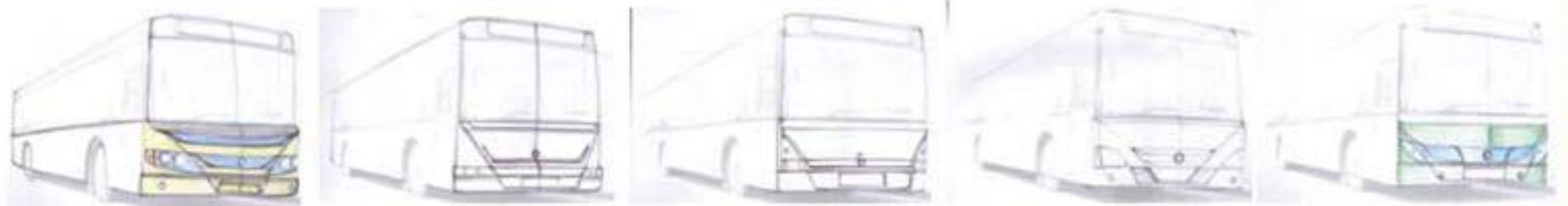
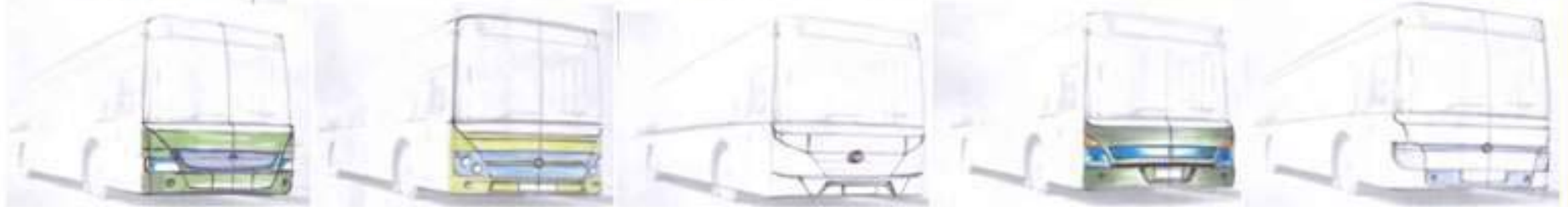
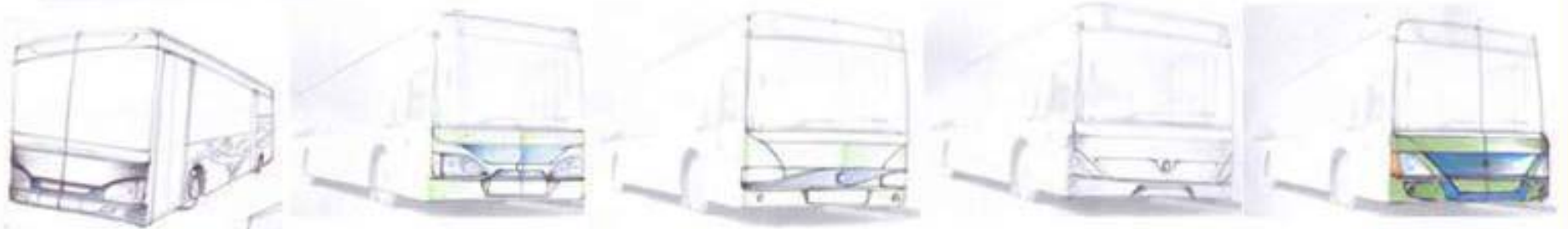

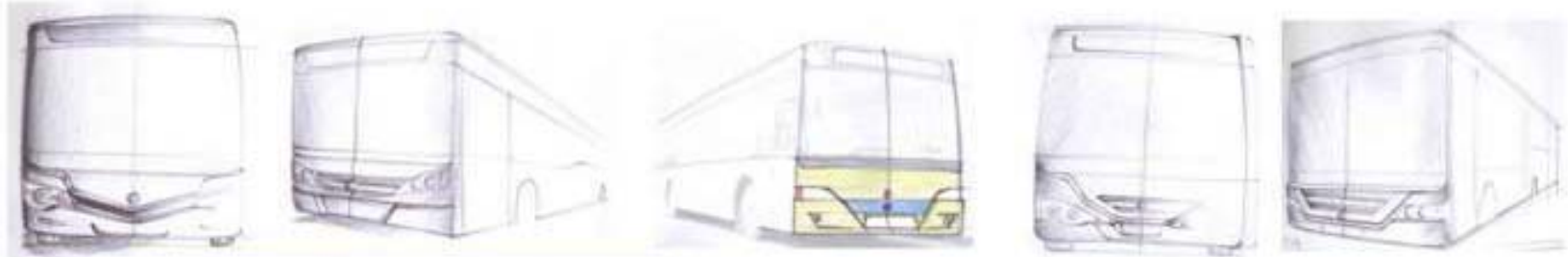
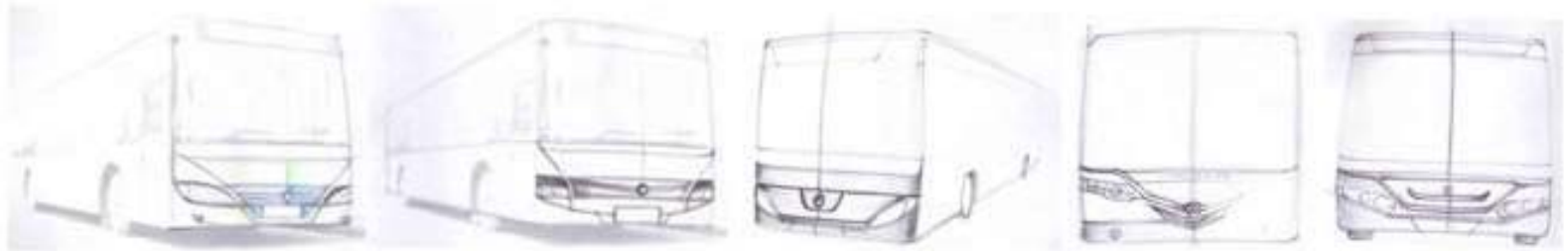

Final concept sketches for low floor bus

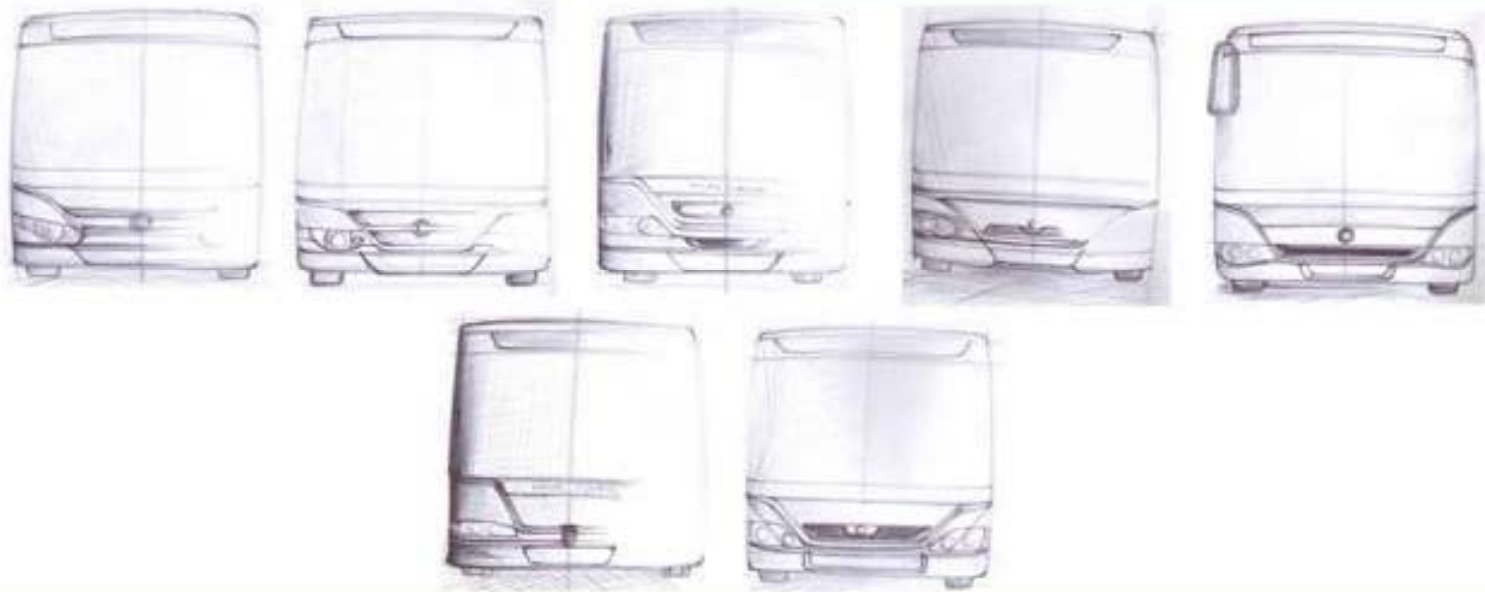

# Doodling (HAND SKETCHES)

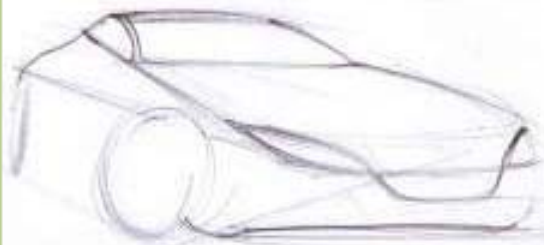
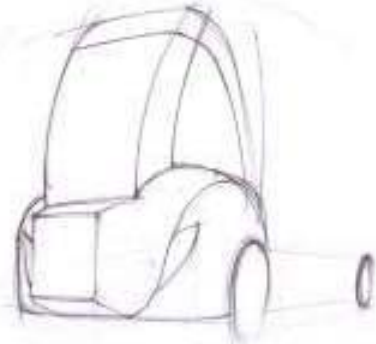
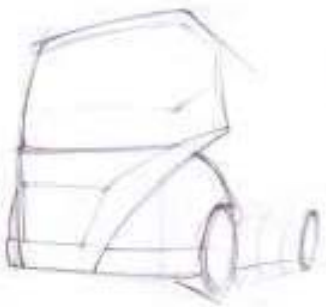
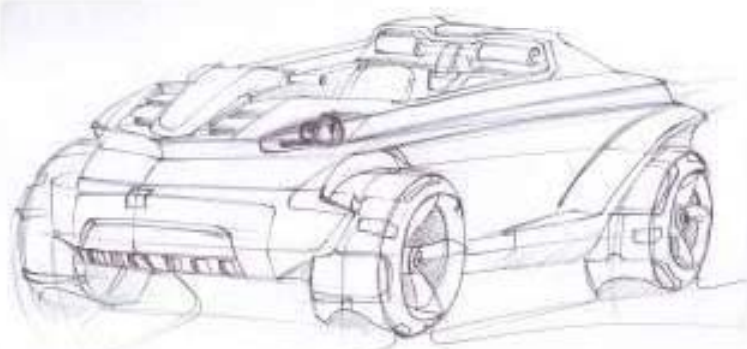

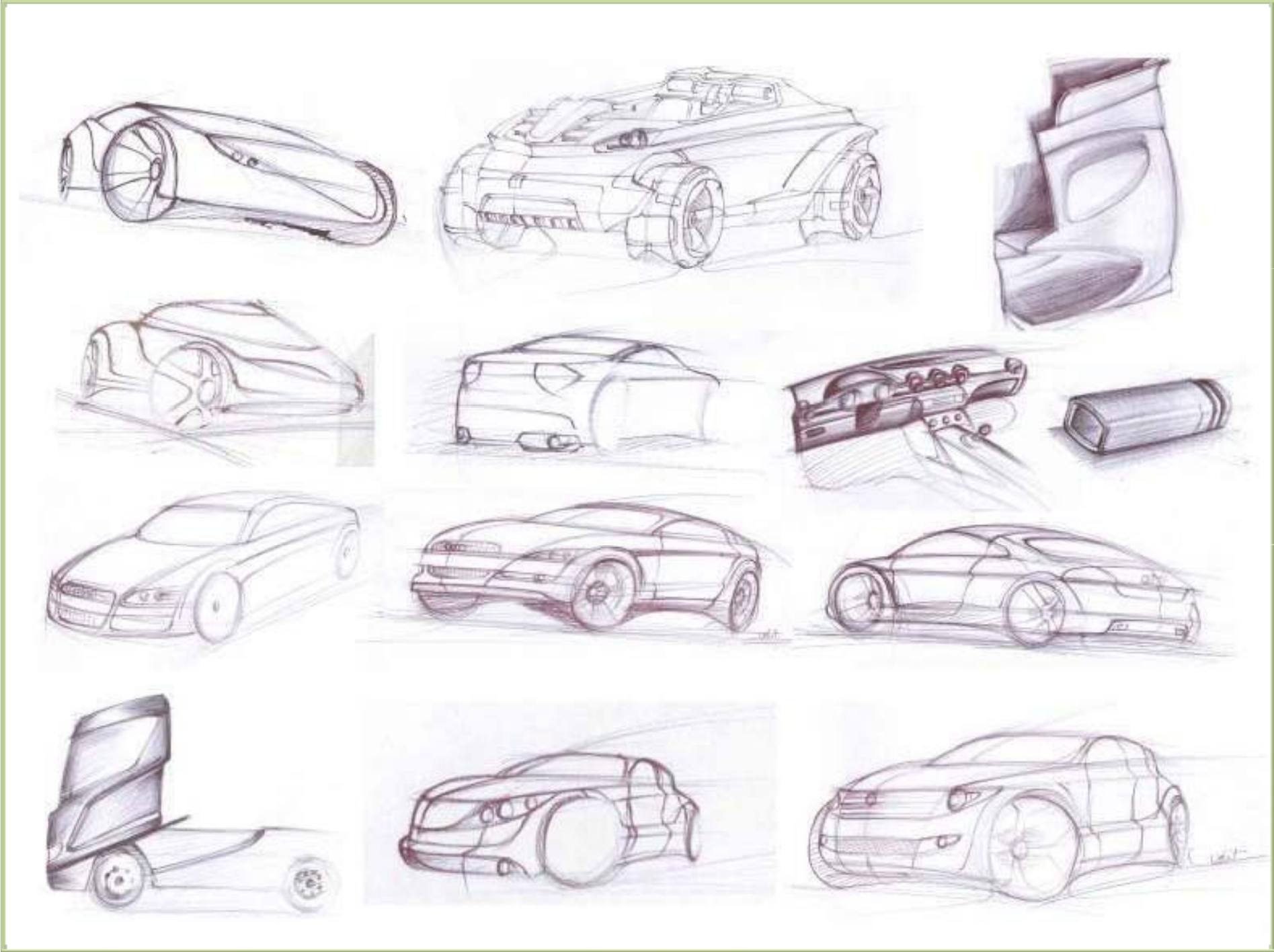

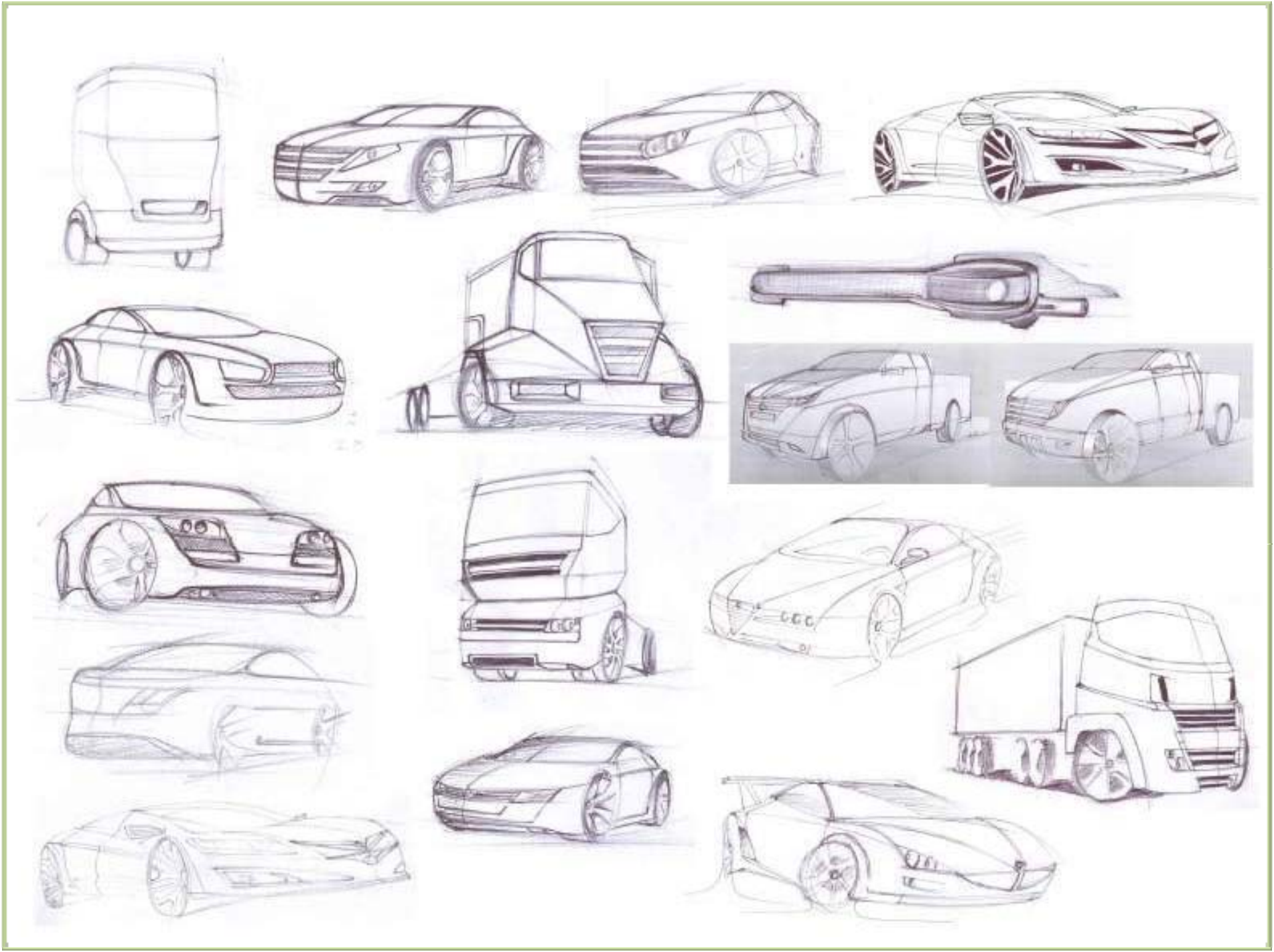

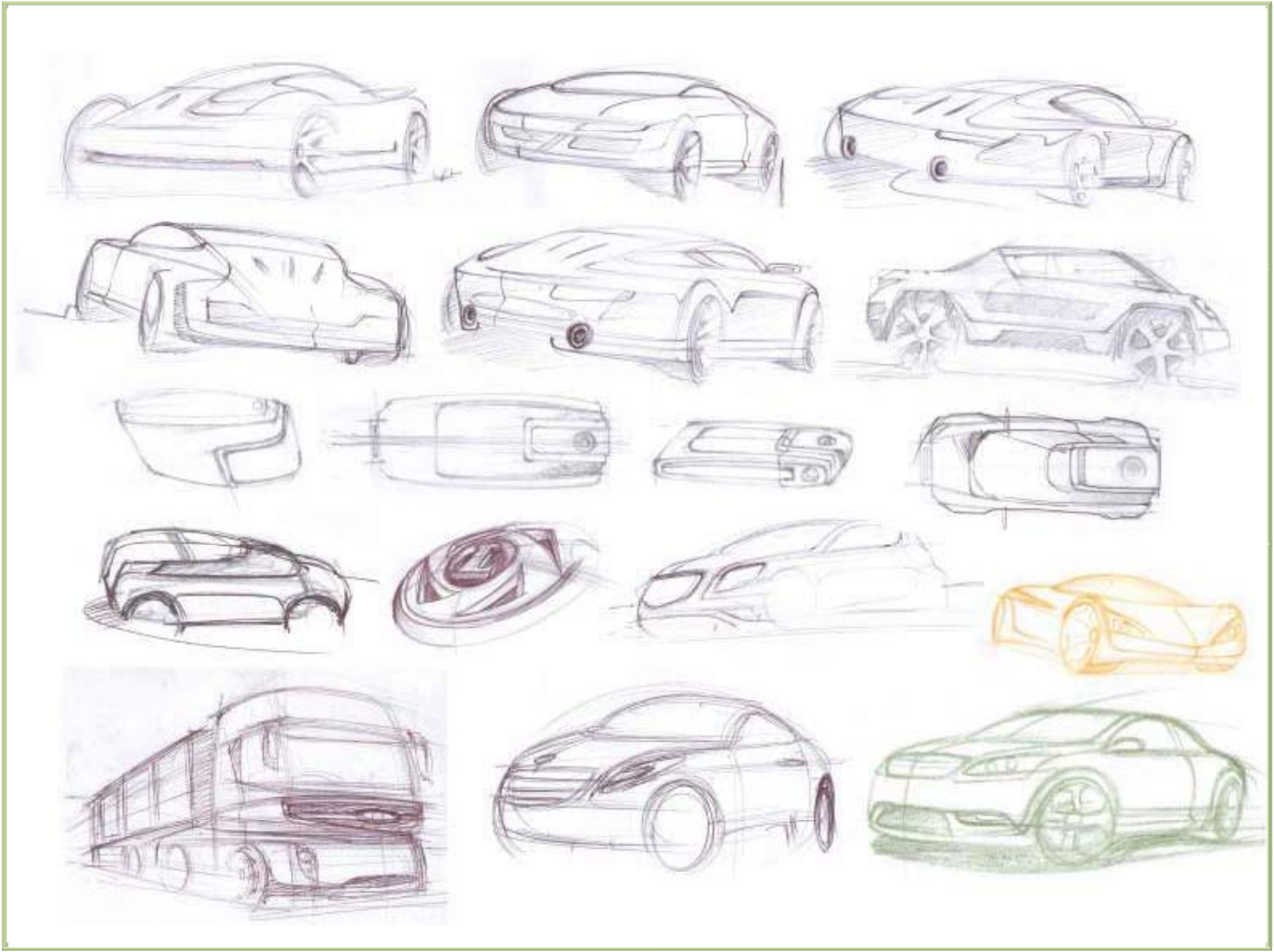

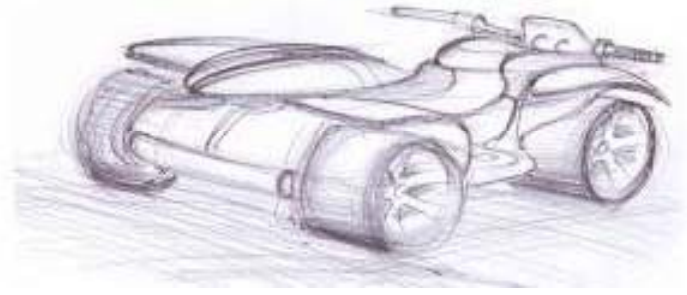
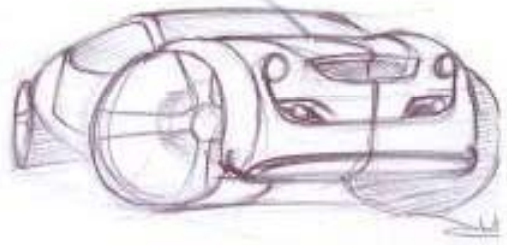
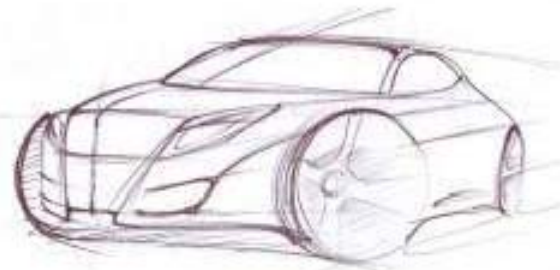
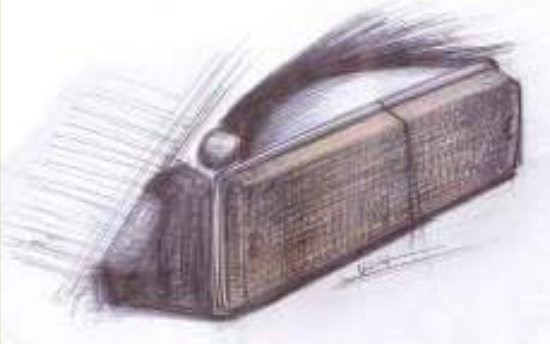
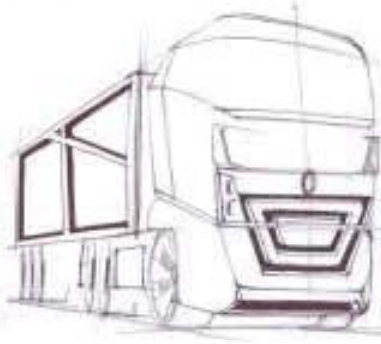

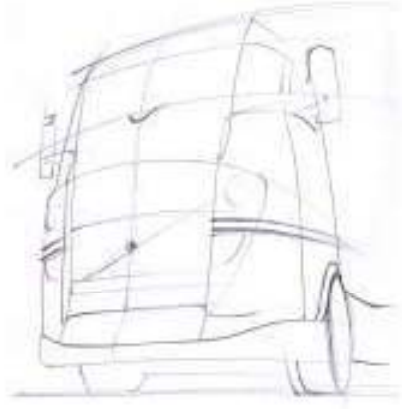



## PHOTOSHOP RENDERING



Modeling work

## Pride...The Car for India

Dynamic and wavy lines of concept.  
"Pride" has small segment car for family.  
I have given name of pride means India's  
pride. Its true Indian car.



I have searched ergonomic condition of small car to opening of back door is always touches to head that's why I have given foldable back door to open and it is also compatible in the parking system, takes few space...



Alias Model and hypershot rendering

## Alite....The Mini Car

Alite is small segment car. It is bulky in nature and gives aesthetic look. Simple and robust design. It is low price car and also called as car in a pocket. It is good for who wants to invest one lacs to buy a car.



Alite....The Mini Car

Alias modelling

# Alite....The Mini Car



Alite....The Mini Car

Alite modeller

It is sport utility vehicle having robust design and aggression in nature. Front grill and the head lamp looks agile in nature. Sporty back light.... Over all it looks ..."King of the Road"



Modeling in "Alias Studio Tools"

## Concept Scooty Model

It is Indian segment product for ladies.  
It gives muscular and aesthetic look.  
It gives comfortable ride.





uditpratapsingh@gmail.com  
Mob No. :- 9945510540  
Phone No. :- 0657-2429973

# Curriculum Vitae

Name :- UDIT PRATAP SINGH

Date of Birth :- 19th Jan 1983

Address :- SB- 156, Supervisor's Flat,  
Sakchi, Jamshedpur – 831001 (Jharkhand)

## Internship

I've done 3 months internship in  
"Ashok Leyland" during 13th  
April 2009 – 20th July 2009 in the  
field of "Product Development"

## Software Skills

Alias Studio Tools  
Pro-E  
Autodesk Maya  
Rhinoceros  
Catia (Exposure)  
Adobe Photoshop  
Corel Draw  
Adobe Dreamweaver

## Education

"Post Graduate in Product Design" from School of  
Post Graduate studies, Nettur Technical Training  
Foundation, Bangalore in the year 2009

B.E. (Mechanical) from S.L.N. College of Engineering,  
Raichur (Affiliated to Visveswaraiah Technological  
University, Belgaum, Karnataka) in the year 2007

Intermediate Science from Mrs. K.M.P.M. Inter College,  
Jamshedpur (Jharkhand Intermediate Examination  
Council, Ranchi) in the year 2001

Matriculation from Kashidih High School, Jamshedpur  
(Bihar Secondary Examination Board) in the year 1999

## References

Dr. N. Ramani  
Principal, School of Postgraduate Studies,  
NTTF,  
Bangalore.  
Ph-09844135720  
pgschool@nttf.co.in

## My Strength

Sketching  
3D Visualization  
Computer Modeling & Rendering  
Fast Learner

Mr. G. Sathiyaseelan  
Assistant General Manager  
Styling Cab  
Ashok Leyland  
Technical Centre  
Vellivoyal Chavadi  
Chennai- 600103  
gsathiyaseelan.alvvc@ashokleyland.com  
Ph- 9789062190

Mr. jyothish Kumar  
Chief Executive Officer  
RAPITECH SOLUTIONS INC.  
# 42, BSK 3rd Stage, 9th Cross,  
Bangalore- 560085  
jyothish@rapitech .co.in  
www.rapitech .co.in  
Mob- +91 9901033712

