

UC-NRLF



QB 26 809

LIBRARY  
OF THE  
UNIVERSITY OF CALIFORNIA.

*Class*







REINFORCED CONCRETE

Published by the  
**McGraw-Hill Book Company**  
New York

Successors to the Book Departments of the  
McGraw Publishing Company      Hill Publishing Company

Publishers of Books for  
Electrical World      The Engineering and Mining Journal  
Engineering Record      Power and The Engineer  
Electric Railway Journal      American Machinist  
Metallurgical and Chemical Engineering

# REINFORCED CONCRETE

MECHANICS AND ELEMENTARY  
DESIGN

BY

JOHN P. BROOKS

*Director Clarkson School of Technology*

*Formerly Associate Professor of Civil Engineering  
University of Illinois*

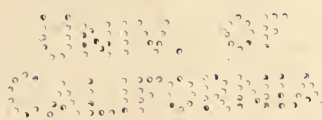

McGRAW-HILL BOOK COMPANY

239 WEST 39TH STREET, NEW YORK

6 BOUVERIE STREET, LONDON, E.C.

1911

Copyright, 1911, BY THE MCGRAW-HILL BOOK COMPANY

TA683  
B7

TO THE  
LIBRARY OF THE  
PLIMPTON PRESS

THE · PLIMPTON · PRESS · NORWOOD · MASS · U · S · A

## P R E F A C E

THIS volume is designed primarily to supplement the usual college work in mechanics and masonry design. With this end in view there is herein no duplication of these subjects. The reader is referred to sources of information regarding the results of tests on reinforced concrete material and only such quotations are given as serve to illustrate principles. The details of reinforced concrete construction are constantly changing and the latest designs are to be found in the engineering periodicals; consequently, matter of this character is not given.

As a guide to the selection of proper constants in designing, much of the report of the "Joint Committee" is given without change, and frequent references to the same are made throughout the book.

The nomenclature is, usually, made up of initials of the words indicated, and for this reason it was thought best to use  $S_t$  rather than  $f_s$  for the tensile stress in the steel. In general, the nomenclature is that in common use.

Several designs of reinforced concrete structures are worked out in detail with particular reference to the proper sequence of computation. The principles of economy in design are set forth and the diagrams in use lead to the proper selection of steel and concrete dimensions.

It is hoped that the book may enable the reader or student to become familiar with the methods of analysis and design of reinforced concrete structures with as little unnecessary work as possible.

J. P. B.

POTSDAM, NEW YORK  
September, 1911.





# CONTENTS

## CHAPTER I

	PAGE
HISTORICAL SKETCH . . . . .	1

Very Early Types of Reinforcement. Development in Europe and in America. Production of Portland and Natural Cement in America. Early Failures of Reinforced Concrete Buildings. Variety of Structures built of Reinforced Concrete. Economy of Reinforced Concrete Structures.

## CHAPTER II

THE COMPONENT PARTS . . . . .	6
-------------------------------	---

### CEMENT.

Definitions. Specific Gravity. Fineness. Time of Setting. Tensile Strength. Constancy of Volume. Sulphuric Acid and Magnesia.

### SAND.

Specifications. Influence upon Strength of Mortar. United States Geological Survey Report. Sieve Analysis. Influence of Weight of Sand. Simple Tests for Sand.

### THE AGGREGATE.

Specifications. The Water. The Steel.

## CHAPTER III

TESTS OF REINFORCED CONCRETE . . . . .	13
--	----

Sources of Information. Tensile Tests. Tension in Plain Concrete Beams. Compressive Tests. Table of Compressive Strength of Concrete. Shearing. Definitions. Tables of Shearing Tests. Tests of Elasticity of Concrete. Tables. The Stress-Strain Diagram. Discussion. Tests of Bond. Length of Grip to Develop Tensile Strength. Flexural Tests. The Neutral Axis. Determination of Neutral Axis by Measurement. Shifting of Neutral Axis under Stresses. Beam Failures, by Compression, by Tension, and by Diagonal Tension. Bond and Shear. Repetition of Stresses. Expansion and Contraction. Weight of Reinforced Concrete.

The Reinforcing Metal. Qualities of Steel. Specifications for Steel. Proportioning Concrete. Quantities in a Cubic Yard of Concrete. Fuller's Rule for Proportioning Concrete. Depth of Concrete Covering of Steel.

## CHAPTER IV

ANALYSIS OF STRESSES . . . . .	37
--------------------------------	----

### BEAM THEORIES.

Navier's Hypothesis. Hooke's Law. The Straight Line Analysis. Nomenclature. Excessive Reinforcement. Under Reinforcement. Double Reinforcement. Effect of Compressive Steel.

### T-BEAMS.

Stresses. Tests of T-beams. Influence of Web Compression. Depth of T-beams.

Flexural Stresses under Ultimate Loads. Parabolic Stress-Strain Diagram. General Parabolic Stress-Strain Relation.

Diagonal Tension in Beams. Distribution of Stresses in Homogeneous Beams. Shear and Axial Stress. Distribution of Stresses in Reinforced Beams. Manner of Failure of Beams. Working Shearing Stresses. Stresses in Web Reinforcement. Spacing of Web Reinforcement. Points of Bending-up Bars. Beams not needing Web Reinforcement. Bond Stresses in Bent-up Bars. Transverse Spacing of Reinforcement. Working Rule for Transverse Spacing. Inclination of Bent-up Rods. Stresses in Concrete due to Bent-up Rods. Water-proof and Fire-proof Qualities of Concrete. Temperature Stresses. Reinforcement for Temperature Stresses. Combined Flexural and Axial Stresses in Beams. Case I, Rectangular Section with Symmetrical Reinforcement, all in Compression. Case II, Tension and Compression in the Section. Flexure and Axial Tension.

### COLUMNS OF CONCRETE.

Columns with Longitudinal Reinforcement. Tests of Plain Columns. Tests of Columns with Longitudinal Reinforcement. Working Loads for Columns with Longitudinal Reinforcement. Columns with Hooped Reinforcement. Stresses in Hoops. Tests of Hooped Columns. Discussion of Tests of Columns. Strength added by the Hoops. Working Loads for Hooped Columns. Columns with Hooped and Longitudinal Reinforcement. Considère's Tests. Working Loads. Long Columns.

### BEAMS SUPPORTED IN MORE THAN TWO PLACES.

Continuous Beams. General Formulas. Working Moments in Continuous Beams. Slabs Supported on Four Sides. Distribu-

tion of Floor Loads to Beams. Girderless Floors. Test of a Girderless Floor.

CHAPTER V

ELEMENTARY DESIGN . . . . . 132

ECONOMICAL PROPORTIONS OF BEAMS.

(a) When the Breadth is Constant. (b) When the Depth is Constant. (c) When the Area of the Cross-sections is Constant. (d) When the Ratio of Breadth to Depth is Fixed. Economic Proportions of T-beams.

REPORT OF THE JOINT COMMITTEE.

Preparation and Placing of Mortar and Cement. Details of Construction. Design. Working Stresses.

DESIGN OF A T-BEAM.

Cross-section According to Shear. Flange Width According to Moments. The Reinforcement. Points for Bending-up Bars. Spacing of Web Reinforcement. The Stirrups-spacing. Investigation of the Flange. Diagram for Solution of Slabs and Beams. Sequence of Computations in the Design of T-beams.

DESIGN OF REINFORCED CONCRETE RETAINING WALLS.

The Lateral Pressure of Earth. Equivalent Fluid Pressure. Types of Retaining Walls.

DESIGN OF A CANTILEVER RETAINING WALL.

The Vertical Wall. Reinforcement in Vertical Wall. Shear at Top of Footing. Design of the Footing. Position of the Vertical Wall on the Slab. The Bearing Power of the Soil. The Outer Cantilever. The Inner Cantilever. Anchoring the Reinforcement. Drainage. Sequence of Work in the Design of Cantilever Retaining Walls.

DESIGN OF A COUNTERFORT RETAINING WALL.

The Vertical Slab. The Footing. The Outer Cantilever. The Inner Floor Slab. The Counterfort. The Reinforcement. Sequence of Work in the Design of a Counterfort Retaining Wall.

THE ARCH. ALGEBRAIC ANALYSIS.

Types. The Three Hinged Arch. The Two Hinged Arch. The Hingeless Arch. Stresses at any Section. Stresses due to Temperature. Effect of Arch Ring Shortening due to Thrust.

THE ARCH. GRAPHIC ANALYSIS.

Principles. Conditions of Equilibrium. Location of  $k' k'$ . The Trial Equilibrium Polygon. The True Equilibrium Polygon. Temperature Stresses. Stresses due to Arch Ring Shortening.

DESIGN OF A REINFORCED CONCRETE ELASTIC ARCH RING.

Loads and Dimensions. Depth of the Keystone. Curves of the Intrados and Extrados. Making  $ds \div I$  constant. The Reduced Load Contour. The Load Diagram. The Trial Equilibrium Polygon. The True Equilibrium Polygon. Stresses due to Loads. Temperature Stresses. Stresses due to Arch Ring Shortening. Final Tension and Compression Stresses. Shearing Stresses. Final Dimensions. Abutments. Sequence of Work in Arch Design.

DESIGN OF A BEAM AND GIRDER FLOOR.

The Beams. The Girders. The Slabs.

DESIGN OF A REINFORCED CONCRETE HOLLOW DAM.

Sequence of Work in Computation.

INDEX . . . . . 217



# REINFORCED CONCRETE

## CHAPTER I

### HISTORICAL SKETCH

THE device of adding material having tensile strength to those that are deficient in this respect has long been practiced by the building trades. The order of the Egyptian taskmasters to their servants that they make "brick without straw," had reference to the custom of mixing some such material to clay to increase its strength. The same practice is common in Central America, where straw is mixed with mud to reinforce the adobe or sun dried brick. It is everywhere common to incorporate animal hair with lime mortar to make the plaster for interior walls. Centuries ago boats in common use on the Nile were of wicker frame with a covering of clay. The clay was deficient in tensile strength, and the wood served as reinforcement. Similar boats, having iron instead of wood and concrete instead of clay, are in rather common use to-day in Italy and also in Panama. The roof of a tomb on Via Appia, Rome, is said to have been found to consist of cement with embedded bronze rods. These tombs were built about 100 B. C. In 1830, in a book called the "Encyclopaedia of Cottage, Farm and Village Architecture," it was suggested that roofs might be constructed of iron rods thickly embedded in cement. In 1840 floors were made of plaster of Paris and iron rods in France, and in 1854 a mason named W. B. Wilkinson is said to have taken out a patent for a floor of concrete and iron in Newcastle-on-Tyne. Even modern methods of construction seem to be old. Recent discoveries in Central America show ancient buildings that have apparently been poured as a unit between wooden forms.

While some of the accounts of the above named practices are somewhat in the nature of rumors, it is certain that what is

now commonly known as reinforced concrete is but a natural adaptation of very old practices to modern building material. From straw and reeds or hair with mud or lime it was but a step to the use of steel and concrete. The use of more expensive material naturally prompted the study of methods to determine the most advantageous distribution of the metal.

The credit for demonstrating the advantages of the combination of iron and concrete in engineering structures seems to belong to a Parisian gardener named Jean Monier. Fortunately he was an engineer by instinct, if not by training, and having interested capitalists in his schemes, he began a highly successful career as a builder of water and gas tanks, sewers, arches, and floors. In a paper read in 1894 before the American Society of Civil Engineers, Fr. von Emberger, C. E., member of the Austrian Society of Engineers and Architects, stated that this method of engineering construction was then sixteen years old and that Monier began his work of this character in 1875. The discussion of this paper brought out the fact that European engineers were, even then, building reinforced concrete arches of over 150 feet span, and of only six inches to eight inches depth at the crown.

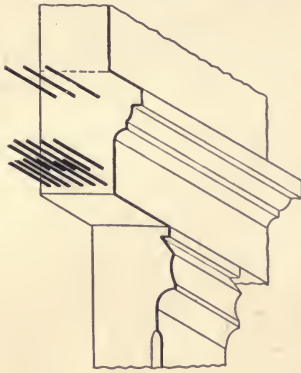

FIG. 1.

even then, building reinforced concrete arches of over 150 feet span, and of only six inches to eight inches depth at the crown.

In this country the development of reinforced concrete construction was hardly less rapid. In "Transactions of the American Society of Mechanical Engineers," Vol. IV, 1888, Mr. W. E. Ward tells of the use of light iron rods and beams embedded in the concrete walls, floors, and cornices of a building erected by him in Port Chester, N. Y., in 1875. The construction shown in Fig. 1 is described in *Engineering News*, Sept. 8, 1888, in its digest of a paper read before the Technical Society of the Pacific Coast, by Mr. G. W. Percy. The lintel shown had a span of 15 feet, a depth of 2 feet 10 inches, and carried three stories of brick wall. What is, possibly, the first reinforced concrete bridge in this country was built with a span of 35 feet in the Golden Gate Park, San Francisco, in 1889.



Since the dates mentioned above, this style of construction has steadily found increasing favor among engineers and architects, and there is scarcely a type of structure that is not sometimes made in this manner. Reinforced concrete may be used in nearly all cases where stone would be acceptable, and in many other cases where the latter is unsuitable on account of the lack of tensile strength.

While there is no definite information at hand as to the amount of reinforced concrete work done yearly in this country, some indication of the facts may be seen by an inspection of the statistics regarding the production of Portland cement in recent years.

Year	Production	Imports	Year	Production	Imports
1880	42,000	187,000	1898	3,584,586	2,119,880
1885	150,000	—	1900	8,482,000	—
1888	—	1,843,814	1903	22,342,973	—
1890	335,500	—	1905	35,246,812	—
1891	454,813	—	1908	51,002,612	839,247
1895	990,324	—	1909	62,508,461	—

The table indicates the production in and imports into United States, in barrels. The marked increase in production after 1900 was, in part, due to the introduction of the rotary kilns and the use of coal as fuel. At the same time the importation was at its height, and it has since dwindled to an almost negligible quantity. Previous to 1890 most of the cement made in this country was of the "natural" variety, which, though well adapted to certain uses, is seldom used in reinforced construction. The increase in the production of Portland cement and the corresponding decrease in that of the natural is shown for three years, in barrels, in the following table:

Variety	1907	1908	1909
Natural .....	2,887,700	1,686,682	1,527,279
Portland .....	48,785,390	51,072,612	62,508,461

Of course, not all of this decided increase in the production of cement can be attributed to the growth of the reinforced

construction, but there is undoubtedly some relation between the two branches of industry.

The enduring qualities of steel-concrete construction have not yet, of course, been fully proved; but the severe tests through which such buildings passed at the times of the Baltimore fire and the San Francisco disaster have gone far toward removing any doubts some may have had at first. Reinforced concrete construction of many kinds is being done as cheaply as of steel, and, in numerous instances, its ability to resist heat, dampness, smoke, and other gases makes it preferable to any other building material. There is little doubt that iron embedded in concrete will resist corrosion indefinitely, as has been shown in several instances where anchor bars have been removed after more than a century of use and exposure.

Reinforced concrete is found in the deepest foundations, and even in the piles upon which the masonry rests. It forms the roof of the structure, and the spires and highest chimneys are made of this material. It is in use in the floors, the ceilings, the walls, the stairs, the cornices, and the handrailings of buildings of every kind. The railroad engineer uses reinforced concrete for ties, for culverts, for arches, for tunnel portals, for round houses, bumping posts, and for trainsheds. The hydraulic engineer builds his dam in the wilderness and his fountains in the city of a combination of cement and iron. The surveyor uses reinforced concrete boundary fence posts, and the electrical engineer uses poles for transmission lines similarly strengthened. The municipal engineer in his designs of sidewalks, curbing, culverts, and sewer pipe, and the naval architect in his rather experimental designs of barges, testify to the great variety of uses to which this type of construction may be adapted.

The remarkable development of this new building construction has not been accomplished without many serious and regrettable failures. Many lives and much property have been destroyed in collapses of buildings erected according to improper designs and lack of intelligent inspection during the building. Men without engineering training, who would not attempt the simplest design in structural steel, have undertaken the design and erection of structures really demanding the services of the most expert. Reinforced concrete was exploited as a building material that, in point of cost, would revolutionize engineering

construction, and extravagant claims were made as to its cheapness. In the attempt to substantiate these claims, practices which tended to bring this class of construction into disrepute became common. However, the industry has passed its period of trial, and it is recognized that, when properly designed and erected, safe and economical results may be effected with its use. The claim of economy is by no means abandoned, but it is based upon the ultimate rather than upon the initial cost.

## CHAPTER II

### THE COMPONENT PARTS

**Cement.** It is assumed that the reader is familiar with the composition, appearance, and usual methods of testing Portland cement, and it is not necessary to review such information here. The following specifications have been approved by the American Society for Testing Materials, the American Society of Civil Engineers, and the American Railway Engineering and Maintenance of Way Association.

#### PORTLAND CEMENT<sup>1</sup>

**Definition.** This term is applied to the finely pulverized product resulting from the calcination to incipient fusion of an intimate mixture of properly proportioned argillaceous and calcareous materials, and to which no addition greater than 3 per cent. has been made subsequent to calcination.

**Specific Gravity.** The specific gravity of the cement, ignited at a low red heat, shall not be less than 3.10; and the cement shall not show a loss on ignition of over 4 per cent.

**Fineness.** It shall have by weight a residue of not more than 8 per cent on the No. 100, and not more than 25 per cent. on the No. 200 sieve.

**Time of Setting.** It shall not develop initial set in less than thirty minutes, and must develop hard set in not less than one hour nor more than ten hours.

**Tensile Strength.** The minimum requirements for tensile strength for briquettes one inch square in section shall be within the following limits, and shall show no retrogression in strength within the periods specified:

<i>Neat Cement</i>	
<i>Age</i>	<i>Strength</i>
24 hours in moist air .....	150 - 200 lb.
7 days (1 day in moist air, 6 days in water) .....	450 - 550 "
28 days (1 day in moist air, 27 days in water) .....	550 - 650 "

<sup>1</sup> Natural cement is not considered here as it is seldom used in reinforced concrete construction.



*One Part Cement, Three Parts Sand*<sup>1</sup>

7 days (1 day in moist air, 6 days in water) . . . . . 150 - 200 lb.  
 28 days (1 day in moist air, 27 days in water) . . . . . 200 - 300 "

**Constancy of Volume.** Pats of neat cement about three inches in diameter, one-half inch thick at the center, and tapering to a thin edge, shall be kept in moist air for a period of twenty-four hours.

(a) A pat is then kept in air at normal temperature and observed at intervals for at least 28 days.

(b) Another pat is kept in water maintained as near 70° F. as practicable, and observed at intervals for at least 28 days.

(c) A third pat is exposed in any convenient way in an atmosphere of steam, above boiling water, in a loosely closed vessel for five hours.

These pats, to satisfactorily pass the requirements, shall remain firm and hard and show no signs of distortion, checking, cracking, or disintegrating.

**Sulphuric Acid and Magnesia.** The cement shall not contain more than 1.75 per cent. of anhydrous sulphuric acid (SO<sub>2</sub>), nor more than 4 per cent. of magnesia (MgO).

*Sand*

Specifications for sand are not nearly as definite or as complete as those for cement, and the two that are given here are those in common use. They are both recommended by the American Railway Engineering and Maintenance of Way Association, the latter specification having special reference to reinforced concrete.

**Sand.** The sand shall be clean, sharp, coarse, and of grains varying in size. It shall be free from sticks and other foreign matter, but it may contain clay or loam not to exceed five per cent. Crusher dust, screened to reject all particles over one-quarter inch in diameter, may be used instead of sand if approved by the engineer.

Fine aggregate shall consist of sand, crushed stone, or gravel screenings, graded from fine to coarse, and passing, when dry, a screen having one-quarter-inch diameter holes; it shall preferably be of siliceous material, clean, coarse, free from vegetable loam or other deleterious matter, and not more than six per cent. shall pass a sieve having 100 meshes per linear inch.

Some of the most thorough experiments upon the effect of the quality of sand upon mortar have been made by the United States Geological Survey and published as Bulletin.

<sup>1</sup> Required by Am. Ry. Engineering and Maintenance of Way Assn. Mortars made of one part Portland cement and three parts fine aggregate by weight when made into briquettes shall show a tensile strength of at least 70 per cent. of the strength of 1 to 3' mortar of the same consistency made with the same cement and standard Ottawa sand.

(C 15)



(B 14)



(A 13)





No. 331. Like most investigations the results are somewhat conflicting, but seem to indicate that a sieve analysis may be relied upon to a considerable extent as a test of fitness of a sand. Photographs of three of the twenty-two samples tested are reproduced in Fig. 2, and sieve analysis diagrams of the same are taken from the above-named bulletin.

The photograph at the top shows the appearance of the poorest of the sands tested, that in the middle one of about average

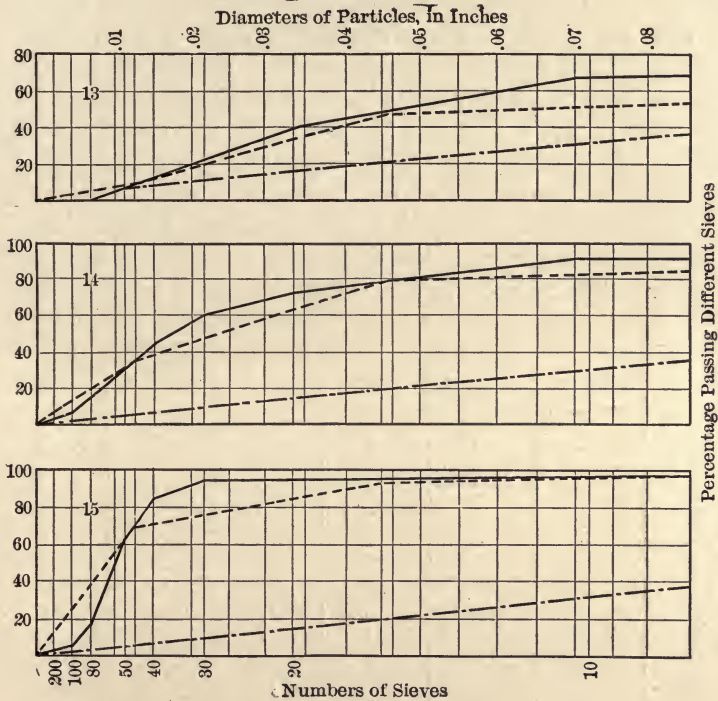

FIG. 3

grade, and that at the bottom of the page one of the very best. This rating is on the basis of compressive strength at the end of 28 days. The even distribution of the large and small grains is at once apparent in *A*, and the lack of large grains is as clearly shown in *C*. If no other information were at hand, *B* would naturally be classed as about an average of the other two. The compressive strengths of these samples in 1 to 3 mixtures at the end of 28 days were: *A*, 5582; *B*, 3159; and *C*, 1898 pounds

per square inch. When samples of *B* were tested in the same way, with all grains omitted except those passing a No. 30 sieve and held on a No. 40 sieve, the strength was reduced to 1969 pounds per square inch.

The diagrams, Fig. 3, show, by the full line curve, the proportions passing each sieve as indicated on the lower line; the straight dotted line is that of a uniform gradation from zero to 100 per cent. on the ordinate for 0.25 inch diameter, since all sand was such as to pass that mesh. Then the area between this line and that of the sieve analysis curve indicates the departure of the sample from the uniform gradation.

The weights per cubic foot of the various sands ranged from 89 pounds to 119.9 pounds; the per cent. of voids from 26.9 to 40.9, and the density of the mortar from 0.676 to 0.808. If the compressive strength of the 1 to 3 mortar at the end of 28 days be the criterion of value, the sands are ranked according to the second column of the following table. The figures in the other columns indicate the rating according to headings.

No.	28 Days	180 Days	Voids	Sieve	Density	Weight
16	1	3	5	1	7	2
19	2	4	1	5	3	1
13	3	2	4	3	9	2
8	4	1	6	4	6	7
20	5	5	2	8	2	5
4	6	6	2	2	1	4
22	7	10	18	12	17	18
6	8	14	8	11	5	8
3	9	9	17	7	10	17
9	10	18	7	6	4	10
2	11	8	16	10	8	13
7	12	7	8	13	16	6
14	13	15	11	14	15	9
17	14	12	14	18	18	15
18	15	17	13	15	14	14
10	16	13	8	17	12	11
5	17	11	15	9	11	16
21	18	19	20	19	19	20
1	19	16	12	16	13	12
15	20	20	19	20	20	19

Two of the sands, Nos. 11 and 12, were omitted from the

above comparison since they were mixtures of sand and stone screenings.

It should be noted that the ranking by weight, by voids, by sifting, or by compressive strength of the best six gives nearly identical results. The poorer samples, also, are detected by any of these methods with nearly the same certainty. The density of the mortar does not seem to indicate the strength with any greater accuracy than does the weight of the sand.

From information, obtained otherwise, concerning mortar made from various sands in general use in Illinois it is reasonably certain that the strength of mortar from the best sands is to that made from the poorest about as 450 is to 150. Also, that 1 to 3 mortar from the best is stronger than 1 to 1 mortar from the poorest. In making these tests the same percentage of water was used with the fine as with the coarse sand, and so the results are not entirely conclusive. As the results are based on the strength of mortar at the end of 90 days, however, there should be little or no error in the inferences.

It would seem from the foregoing that it is economy to use the better grades of sand, even at great expense for transportation. When the prices of cement and of the several varieties of available sands are known, the relative economy of various mixtures may be computed.

In the tests of the United States Geological Survey, noted above, were included those on gravel and broken stone screenings. The results showed that either of these may be safely used instead of sand, and in general with even better results.

By means of three tests that are readily made the relative value of various sands may be judged quite accurately. These tests are:

- (a) The appearance.
- (b) The feeling.
- (c) The weight.

The better sands show a generous sprinkling of coarse grains mixed with the fine material and intermediate gradations.

The grains should be of irregular shapes even though smooth; but sharpness is desirable. Upon rubbing the sand in the palm of the hand, traces of clay should be seen.

The heavier the sand the better. Well shaken sand should weigh over 100 pounds per cubic foot when dry.



*The Aggregate*

**The Aggregate.** Coarse aggregate shall consist of crushed stone or gravel, graded in size, and which is retained on a screen having one-quarter inch diameter holes; it shall be clean, hard, durable, and free from all deleterious material. Aggregates containing soft, flat, or elongated particles shall not be used.

The maximum size of the coarse aggregate shall be such that it will not separate from the mortar in laying and will not prevent the concrete fully surrounding the reinforcement or filling all parts of the forms. Where concrete is used in mass the maximum size of the coarse aggregate may, at the option of the engineer, be such as to pass a 3-inch ring. For reinforced concrete, sizes are usually not to exceed one inch in any direction, but may be varied to suit the character of the reinforcement.

**The Water.** The water used in mixing concrete shall be free from oil, acid, alkalis, or vegetable matter.

**The Steel.** The metal reinforcement steel shall . . . be free from dust, scale, or coatings of any character which would tend to reduce or destroy the bond.

The ultimate tensile strength, in pounds per square inch, shall be 60,000 for structural steel and 85,000 for high carbon steel.

Bending tests may be made by pressure or by blows. Shapes and bars less than one inch thick shall bend through 180° flat without breaking it of structural, and through 180° around a diameter of four times the thickness if of high carbon steel.

Structural steel 1 inch thick and over, tested as rolled, shall bend cold 180° around a pin, the diameter of which is equal to twice the thickness of the bar, without fracture on the outside of the bend.

Further specifications regarding the fabrication of reinforced concrete will be given in another chapter.

**PROBLEM<sup>1</sup>**

Let the mixture be 1:3:6, and let a cubic yard be composed of 0.96 barrel of cement, 0.41 cubic yards of sand, and 0.82 cubic yards of stone. Let the cost of the cement be \$1.80 per barrel, and that of the stone \$1.25 per cubic yard. Let sand at 50 cents and at \$1.50 per cubic yard be available. Which sand is the more economical if the compressive strength of the corresponding concrete be 1500 and 1800 pounds per square inch respectively? How will the relation be changed if the cost of labor be added?

## CHAPTER III

### TESTS OF REINFORCED CONCRETE

**Sources of Information.** Much of the information regarding the strength of building material is derived from experiments conducted in the testing laboratories of the various technical schools of the country. The results of these tests, with conclusions drawn therefrom by the directors in charge, are published in pamphlet form from time to time, and are for distribution at nominal charge. Some of these experiments are conducted by a regularly employed corps of men, some personally by the director, with occasional help, and some as thesis work of senior engineering students under careful supervision.

The United States Government maintains several laboratories, notably one at Watertown, Mass., where some of the most reliable information has been gathered. The results of this work are published annually as *Tests of Metals*, a pamphlet that is for distribution at moderate price.

The transactions of the national engineering societies contain papers by eminent men concerning researches of this character. The societies, as bodies, do not conduct tests, but the discussions bring out much of the combined knowledge of the individual members. Among such societies may be named the American Society for Testing Materials, the Western Society of Engineers, the American Society of Civil Engineers, and the American Railway Engineering and Maintenance of Way Association.

Several of the more local engineering organizations are united in publishing the "Journal of the Association of Engineering Societies," with headquarters at present in Boston.

In foreign countries there is as much activity in collecting information of this character and in making it known as is the case here. Everywhere the designer is restricted less by lack of reliable tests than by intelligent interpretation of the same.

It is not the purpose here to quote fully from any of the above named sources, and what immediately follows is general rather than in detail. The values representing the strength of the materials under various circumstances of strain in the examples and problems in later parts of the book are supposed to represent reasonable practice only and not definite recommendations.

The tests of reinforced concrete are naturally divided into two parts: those of the component materials, as the cement, mortar, concrete, and steel; and those of the combination of the whole into shapes suitable for building purposes. Only the latter are of such individuality as to require more than casual reference here.

TENSILE STRENGTH OF CONCRETE

Mixture	Age Days	Strength in Lb. Per Square Inch.	Authority
1:3:6	50	178	<i>a</i>
1:3:6	60	160	
1:3:6	84	170	
1:3:0	87	278	
1:3	90	179	<i>b</i>
1:4	90	130	
1:3	2 years	220	
1:2:4	28	142	<i>c</i>
1:2:4	28	160	
1:2:5	28	237	<i>d</i>
1:2:5	90	359	
1:5	28	253	
1:5	90	290	

(a) Bulletin No. 1 University of Illinois Engineering Experiment Station, 1904. Stress was applied to cylinders 8" diameter and 32" long, by means of a rod ending in a socket joint in a steel disc, 8" in diameter, bolted to each end of the specimen. Unless otherwise stated the author of all bulletins of the University of Illinois Engineering Experiment Station, from which quotations are made in this book, is Professor A. N. Talbot.

(b) Eisenbetonbau, Emil Moersch, Zurich. The mixture was of cement, sand, and gravel, the exact proportions not being stated.

(c) Bulletin No. 2, Vol. 4, University of Wisconsin, 1908.

(d) Journal of the Association of Engineering Societies, September, 1900.

**Tensile Tests.** In order that tests of concrete in tension may indicate what may be expected as to the strength of such



material in construction work, the test pieces must be fairly large. As the aggregate contains pieces two inches or more in diameter, there are apt to be many unfilled spaces around the outside surface, and in small sections these cavities form larger proportions of the whole area than in large ones. Hence, results obtained in breaking small pieces are not commensurate with the strength of parts used in actual construction. The difficulties attending the making of tensile tests are, in part, due to the fact that it is very hard to so plan the experiments as to cause a uniform distribution of the load over the whole cross section if its area be large. As concrete is seldom required to resist direct tension, the lack of conclusive tests of this kind is of little comparative consequence.

The tests on beams furnish an indirect method of finding the tensile strength by computation. Results derived in this way show a modulus of rupture for plain concrete beams nearly double the results given above. In the bulletin (a) above, the following tests of plain concrete beams are given.

TENSION IN PLAIN CONCRETE BEAMS

Mixture	Age Days	Section Square Inch	Span	Strength Lb. Per Sq. In.
1:3:6	64	12" × 13½"	14'	412
"	65	"	14'	337
"	64	"	14'	322
"	62	"	10' 8"	390
"	62	"	10' 8"	355
"	61	"	8' 6"	347
"	62	"	8' 6"	422
"	61	"	5'	299
"	64	"	5'	299

The principal use of the tensile strength in beams is in taking some of the diagonal stresses, as will be shown later. The reason for the discrepancy between the values in the last table and those derived from direct tension will be more fully explained later. Briefly, the reason is that, for great and small deformations, the corresponding stresses are not in the same ratio either on the tension or compression sides or as between the two.

The practice is to disregard the tensile strength of concrete

and to assume that all the tensile stresses are carried by the steel. The safe tension combined with shear, or diagonal tension in beams, is assumed as 50 pounds per square inch.

**Compression Tests.** As concrete is used in direct compression, and as stresses of this kind occur during flexure, many tests have been made to determine the reliable unit strength.

COMPRESSIVE STRENGTH OF CONCRETE

Mixture	Age Days	Strength Lb. Per Sq. Inch	Authority	Mixture	Age Days	Strength Lb. Per Sq. Inch	Authority
1:1½:3	355	4590		1:2:4	58	3210	
1:2:4	330	3175		1:2:4	60	2620	
					83		a <sub>1</sub>
1:4:8	343	1315		1:2:4		3080	
1:4:8	202	1294		1:5:10	60	903	
1:5:10	334	1157	a	1:5:10	64	1098	
1:5:10	184	819		1:5:10	69	897	a
1:2:4	267	2110		1:2:4	34	407	
				1:2:4	17	664	
1:1:2	66	4238	a <sub>1</sub>	1:2:4	11	1517	
1:3:6	60	2428		1:2:4	6	836	
1:3:6	65	1400		1:4:8	62	1573	
1:5:10	69	1115					
				1:3:6	180	3088	
1:2:4	180	3826		1:3:6	90	2522	
1:2:4	90	2896		1:3:6	30	2164	b
1:2:4	30	2399	b	1:3:6	7	1311	
1:2:4	7	1565					
				1:2:5	30	769	c
1:1:3	30	1466					
1:2:3	30	1098	c	1:2:5	30	750	
1:2:4	30	904		1:3:6	30	550	d
				1:3:6	30	450	
1:2:4	30	1000	d				

(a) Bulletin No. 29, Univ. of Ill., 1908, Engineering Experiment Station. Each result as given is the average of several tests, there being thirty of these in the sixty day, 1:2:4 result. In the tests of specimens over six months old the age given is the average of several within narrow limits. The sand, stone, and the several varieties of cement used were considered to represent first class practice. The test pieces were 6" cubes. (a<sub>1</sub>) Bulletin No. 8.

(b) Tests were made for Boston Elevated Railway Company at the Watertown Arsenal. Tests of Metals 1899. The test pieces were 12" cubes.

(c) Tests of Metals, 1898. Portland cement and cinder concrete, 12" cubes.

(d) Journal Assn. Engineering Societies, Sept., 1900. Portland cement and unscreened cinder concrete. The test pieces were 3½" × 3½" × 11".

An analysis of the above table shows that concrete increases decidedly with the richness and age of the mixture. Other factors affecting the strength are the amount of water used, the care taken in mixing and in breaking, and the size and quality of the stone. Even when these factors are supposed to be constant, results lack much of exact agreement. For example, there seems to be no apparent reason why, in (a) above, the 1:4:8 mixture at 62 days should be stronger than the same mixture at 343 days old, or than the 1:3:6 mixture at the age of 65 days. Any tests such as these, gathered from most reliable sources, are only indicative and not at all conclusive as to what may be expected under slightly different conditions. However, the same conditions are found in all building material, to some extent, and the factor of safety must be chosen accordingly.

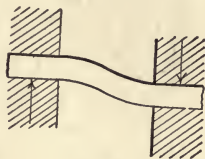

FIG. 4.

A well made 1:2:4 concrete is usually assumed to carry 600 pounds per square inch in compression, while 400 pounds per square inch may be taken as a safe load for a 1:3:6 concrete.

**Tests of Shearing.** The term shear is used by different experimenters and writers to express very dissimilar actions. The word, of course, suggests a cutting by sharp edges acting in opposite directions and close together. In this case the upper and lower fibers are broken or cut first, the fibers adjacent to these are then severed, and, in turn, the next and so on. If



FIG. 5.

the opposing external forces be not close together, bending results, as is shown in Fig. 4, if the ends of the piece subjected to shear be held rigidly, or by single flexure if they be not so held. The latter action is present in loaded beams and failure so caused is often called shear, whereas it more nearly resembles tension. True shearing is seldom accomplished without some attending compression. When a prism is broken by compressive forces, fracture usually takes place by a diagonal rather than by an axial displacement, that is, one end takes an offset and is pushed by the other, as is shown in Fig. 5. This particular

method of failure is especially noticeable in wood, while stone



and concrete may break on four sides in succession, leaving a pyramidal fracture. If the plane of fracture in Fig. 5 be at  $45^\circ$  with the direction of the forces, the compressive strength of the material is fully two times the shearing strength, as is readily shown by the resolution of the forces.

In the earlier tests to determine shearing strength the effect of bending was not considered, and the resulting values were given as being from one-sixth to one-fifth of the compressive strength. The tests given below were made in a different manner, and the results are much higher.

Form of Specimen	Mixture	No. of Tests	Strength, Lb. Per Sq. In.			Shear + Compression	
			Shear	Compression		Cube	Cylinder
				Cube	Cylinder		
Plain plate . . . . .	1:3:6	9	679	1230	—	.55	—
	1:3:6	7	729	1230	—	.59	—
	1:3:6	4	905	2428	1322	.37	.68
	1:3:6	1	968	1721	1160	.56	.83
	1:2:4	5	1193	3210	2430	.37	.49
Recessed block . . .	1:3:6	17	796	1230	—	.65	—
	1:3:6	5	879	1230	—	.71	—
	1:3:6	4	1141	2428	1322	.47	.86
	1:3:6	1	910	1721	1160	.53	.79
	1:2:4	5	1257	3210	2430	.39	.52
Reinforced recessed block .	1:3:6	4	1051	1230	—	.86	—
	1:3:6	4	1821	2428	1322	.75	1.38
	1:3:6	1	1555	1721	1160	.90	1.39
	1:2:4	5	2145	3210	2430	.67	.80
Restrained beam .	1:3:6	4	1313	2428	1322	.54	1.00
	1:3:6	1	1020	1721	1160	.59	.88
	1:2:4	6	1418	3210	2430	.44	.58

This table is taken from Bulletin No. 8, University of Illinois Engineering Experiment Station. The test pieces had, with six exceptions, been stored for 60 days in damp sand. The first, sixth, and twelfth were stored in air, and the second, seventh, and eighth were kept under water. The plain concrete specimens were blocks 13 inches square and 3 inches deep. The recesses in the other blocks were slightly larger than the plunger, of  $5\frac{7}{8}$  inches diameter, which was applied to the plain side. In the other blocks reinforcing rods were inserted outside



the area to be punched to prevent splitting. The restrained beam was 4 inches square in section, and had a clear span of  $4\frac{1}{8}$  inches, while the plunger was 4 inches square.

The following tests were made in 1905, at the Massachusetts Institute of Technology, on cylindrical beams 5 inches in diameter, clamped at the ends, and having a clear span of 6 inches. The pressure was applied by a cast-iron plunger having a cylindrical bearing on the beam, so that, as in the beam mentioned above, the shearing took place through two sections.

Mixture	Method of Storing	Shearing Strength Lb. Per Square Inch			Crushing Strength	Shear + Compression
		Maximum	Minimum	Average	Lb. Per Square Inch	
1:2:4	Air	1630	960	1310	2070	.63
1:2:4	Water	2090	1180	1650	2620	.63
1:3:5	Air	1590	890	1240	1310	.94
1:3:5	Water	1380	840	1120	1360	.32
1:3:6	Air	1450	950	1180	950	1.25
1:3:6	Water	1200	1030	1120	1270	.88

In sections where shear, unaccompanied by tension, is considered, it is usual to assume 120 pounds per square inch as the working strength for good 1:2:4 concrete. The safe unit shear in beams without diagonal reinforcement is about 40 pounds per square inch.

**Tests of Elasticity.** Although concrete is not elastic to the same extent that steel is, yet it has the tendency, after the application and removal of light loads, to return to its original shape. If a load be applied just large enough to produce a small permanent set and then removed, other smaller loads may be repeatedly applied and released without creating much, if any, further permanent set. To this extent concrete may be considered sufficiently elastic to warrant the application of the elastic theory to the analysis of stresses.

Some of the most reliable tests of the elasticity of concrete have been made at the Watertown Arsenal, and the results may be found in "Tests of Metals" since 1898. The following table is from that source, 1899.

Mixture	Age	Coefficient of Elasticity Between Loads, in Lbs. Per Square Inch, of			Compressive Strength Lbs. Per Sq. Inch
		100-600	100-1000	1000-2000	
1:2:4	7 days	2,593,000	2,054,000	1,351,000	1730
1:2:4	1 mo.	2,662,000	2,445,000	1,462,000	2567
1:2:4	3 mos.	3,671,000	3,170,000	2,158,000	2975
1:2:4	6 mos.	3,646,000	3,567,000	2,582,000	3989
1:3:6	7 days	1,869,000	1,530,000	—	1511
1:3:6	1 mo.	2,438,000	2,135,000	1,219,000	2260
1:3:6	3 mos.	2,976,000	2,656,000	1,805,000	2471
1:3:6	6 mos.	3,068,000	3,503,000	1,868,000	3068
1:6:12	1 mo.	1,376,000	—	—	1146
1:6:12	3 mos.	1,642,000	1,364,000	—	1359
1:6:12	6 mos.	1,820,000	1,522,000	—	1592
<sup>1</sup> 1:2:5	1 mo.	1,040,000	—	—	724

The concrete was made of good quality Portland cement, bank sand, and broken conglomerate stone.

The following table is taken from Bulletin No. 10, Univ. of Illinois Engineering Experiment Station.

Mixture	Age Days	Gauged Length Inches	Coefficient of Elasticity Lbs. Per Sq. Inch	Maximum Com- pressive Strength Lbs. Per Sq. Inch
1:2:4	69	114	3,150,000	1722
1:2:4	64	114	2,530,000	2004
1:2:4	65	114	2,500,000	1615
1:2:4	61	60	2,370,000	1709
1:2:4	63	60	2,000,000	1189
1:2:4	65	60	1,490,000	1079

It will be seen that the two sets of tests agree fairly well, and also that, in the same specimen, different coefficients exist under different loads.

Experiments made at the same time on reinforced concrete columns give practically the same values for the coefficient of elasticity as those given above for plain concrete.

**The Stress-Strain Diagram.** Such diagrams are made by plotting the observed unit stresses as ordinates and the corre-

<sup>1</sup> Cinder concrete.

sponding deformations as abscissas. This process will, with concrete, produce a curve in which the abscissas increase faster than the ordinates.

In Fig. 6 is shown a typical curve of this kind for concrete. The inclination of the tangent to the curve at the beginning represents the coefficient of elasticity for small loads when first applied, and is sometimes referred to as the "initial coefficient" or modulus. This tangent is practically identical with the curve *ab* until the loads exceed 500 pounds per square inch. If the load be released the deformation will not become zero, but a set as *ac* will occur. When the load is again applied the stress-strain curve follows *cb* closely for small loads, but the curvature rapidly increases as the loads become greater. A second release and a third application of the loads fixes another loop in the curve, and so on till the load equals the ultimate strength.

The behavior of the concrete as shown by the stress-strain diagram, gives rise to some confusion as to what is the coefficient of elasticity. The tangent of the angle of inclination of the straight line through *a* and *d* is called the gross or secant coefficient, while that through *e* and *d* is the net or elastic coefficient. In comparing coefficients of elasticity, it is necessary to note whether or not the stresses were within the same limits. If the concrete represented in Fig. 6 contain reinforcement, it is evident that the stress in the latter is indicated by *a d'* rather than by *e d'*, and here the gross coefficient is clearly the more appropriate. On the other hand, the net coefficient  $dd' \div ed'$  more nearly represents the elastic properties under low stresses after the second release of the loads.

It is quite evident that, in considering all stages of loading from zero to the ultimate, a constant coefficient should not be used, and it is common to assume the stress-strain curve to be a parabola and make the analyses accordingly. The parabola in Fig. 7 has its axis vertical, and the maximum ordinate is the

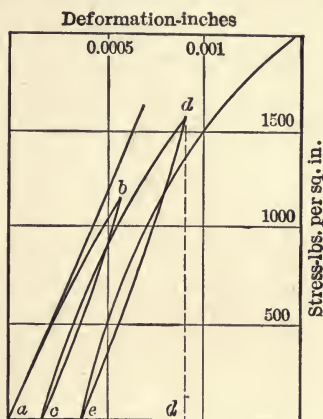

FIG. 6.



ultimate strength of the concrete. The few experiments that have been made to determine the coefficient of elasticity of concrete in tension seem to indicate that, for small stresses, it is practically the same as in compression, although probably slightly less.

In practice it is usual to assume that the ratio of the coefficient of elasticity of steel to that of rich, well-made concrete is 15, and 18 to that of the leaner mixtures.

**Tests of Bond.** The whole success of reinforced concrete construction depends upon the adhesion, or bond, between the metal and the concrete. This bond is effective from two causes,

which are similar to those holding a wooden dowel in place in a hole of a diameter slightly smaller than itself. In the first place, friction, caused by pressure between the surfaces in contact, makes withdrawal difficult. In the second place, the dowel may be fixed, with little friction, if the surfaces in contact be covered with glue. Experiments prove that the metal reinforcement may be moved slightly with reference to the

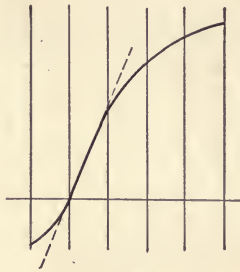

FIG. 7.

concrete, as by a sharp blow, and still leave about half of the bond strength effective.

Tests to determine the strength of bond are usually made by pulling out a rod that has been imbedded in a block of concrete. A few have been made by forcing the steel out by compression. In either case the concrete is in compression, which fact has the tendency to increase the friction by adding to the pressure at the surfaces in contact. This condition is realized when the upper part of a simple beam has reinforcement. The steel in the tension side of a beam acts under different conditions. Here the concrete is in tension and often cracked, and the pressure between the surfaces must become less. In comparing values of bond strength from different experiments, the manner of making the tests must be kept in mind.



Number of Tests	Type of Rod	Size Inches	Mixture	Length of Grip Inches	Maximum Load Pounds	Bond Lb. Per Sq. In.	Friction Lb. Per Sq. In.
6	Plain round	$\frac{1}{2}$	1:3:5 $\frac{1}{2}$	6	3498	372	210
6	" "	$\frac{1}{2}$	1:2:4	6	3893	412	227
6	" "	$\frac{5}{8}$	1:3:5 $\frac{1}{2}$	6	4170	355	227
4	" "	$\frac{5}{8}$	1:2:4	6	5376	465	297
3	" "	$\frac{1}{4}$	1:3:5 $\frac{1}{2}$	12	7035	373	268
4	" "	$\frac{1}{2}$	1:2:4	12	7605	404	266
3	" "	$\frac{5}{8}$	1:3:5 $\frac{1}{2}$	12	9458	402	228
3	" "	$\frac{5}{8}$	1:2:4	12	9736	414	223
3	Cold rolled shafting	1	1:3:5 $\frac{1}{2}$	6	2570	136	67
3	" " "	$\frac{1}{2}$	1:3:5 $\frac{1}{2}$	6	1476	157	50
3	Mild steel	$\frac{3}{16} \times 1\frac{1}{2}$	1:3:5 $\frac{1}{2}$	6	2536	125	84
3	Round tool steel	$\frac{3}{4}$	1:3:6	6	2077	147	—

The above table is from Bulletin No. 8, University of Illinois Engineering Experiment Station. In these tests the rod was imbedded in the whole thickness of the concrete, which was such that the elastic limit of the steel was not exceeded during the test. The concrete blocks were cylinders 6 inches in diameter, and were, at the time of the tests, 60 days old.

The following tests were made at the University of Wisconsin, and were published in *Engineering Record*, Vol. LVII, p. 798. They were made on beams in which the lower reinforcing bar was imbedded only a short distance from each end, leaving the middle portion exposed. The stress in the rod was computed from the observed deformation.

Mixture	Age Days	Diameter of Rod Inches	Bond Lb. Per Sq. In.	Bond by Direct Tension Lb. Per Sq. In.	Ratio
1:2:4	60	$\frac{3}{8}$	278	394	1.42
1:2:4	60	$\frac{1}{2}$	286	455	1.54
1:2:4	60	$\frac{5}{8}$	276	—	—
1:2:4	60	$\frac{3}{4}$	264	502	1.90
1:2:4	60	1	163	487	2.99
1:2:4	28	$\frac{5}{8}$	236	—	—
1:2:4	28	$\frac{5}{8}$	266	—	1.76

It will be noted in the former table that the unit bond strength was practically the same whether the bar was imbedded 6 inches

or 12 inches, that it was greater with the richer concrete, and was much affected by the surface of the steel. The latter table shows clearly the marked difference in results from the two methods of making the tests. Nowhere is there any marked difference due to size of the rod.

With the intention of increasing the bond, many specially rolled bars of varying cross-section have been put upon the market. Some of these are shown in the advertising pages of all engineering periodicals. New designs are being made constantly and as many are being discontinued.

Tests made with these bars show considerably higher bond strength due to the mechanical bond produced by the inequalities of the cross-section, especially after the first slip has taken place.

In Europe it is a common practice to bend the rods into hooks at the ends as shown in Fig. 8. The corrugated bars do not find the same favor there as in this country, the contention being that there is a greater liability of splitting the concrete than when plain reinforcement is used. Such undoubtedly is

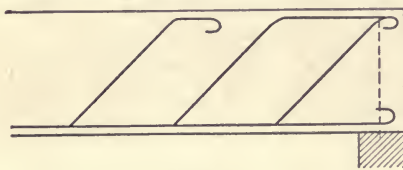

FIG. 8.

the tendency, as the concrete that fills the indentations is sheared; but this action takes place only after plain bars would have slipped. The effect of the hook is of a somewhat similar nature

in that it prevents sudden failure after initial slip has taken place. As will be shown, it is sometimes impracticable to secure a length of grip sufficient to develop the strength of the bars, and in such event the hooked end or other form of anchoring is effective.

The above tables show that bond strength in beams is about 250 pounds per square inch of contact. A reasonable factor of safety would indicate that, for plain bars, the working strength should be taken at about 65 to 80 pounds. If deformed bars be used the bond may be assumed to be 100 pounds per square inch.

Let  $S_t$  be the working tensile strength of the steel,  $d$  the diameter or thickness of the bar, and  $u$  the unit bond strength. Then, to develop the strength of the steel, whether round rods

or square bars, the length of imbedment or grip should be determined from

$$\frac{1}{4} \pi d_1^2 S_t = \pi d_1 x u \text{ for rods}$$

or 
$$d_1^2 S_t = 4 d_1 x u \text{ for bars}$$

whence 
$$x = \frac{d_1 S_t}{4 u} \tag{1}$$

where  $u$  is the average unit bond stress between the concrete and the steel over the length  $x$ . With usual values this indicates that the grip should be about 50 diameters of the rod.

The bond stress on the bar in a certain length depends upon the change in tensile stress in the bar within the same distance. In the distance  $dx$  the change in the bending moment is  $dM$  and the unit change is  $dM \div dx = V$ , according to the principles of mechanics of homogeneous beams. For equilibrium the bending moment equals the resisting moment which is  $AS_t j$ , in which  $A$  is the cross-section of the steel, and  $j$  is its lever arm. Then, differentiating,  $dM = A j dS_t$ , and by substitution

$$\frac{A dS_t}{dx} = \frac{V}{j}$$

The first member is the change in tensile stress in the bar per unit of length. If the concrete and steel be in contact, the same stress must take place in the bond per unit of length, which is  $mo u$ , where  $o$  is the periphery of the bar and  $m$  is the number of bars in the section, if the bars be alike, or in any case,  $mo$  is the sum of the peripheries of all the bars in the section. Then  $mo u = V \div j$  and

$$u = \frac{V}{moj} \tag{2}$$

In many instances the thickness of a beam will be governed by this determination of  $j$ , rather than by the bending moment.

The results of some tests of bond stresses in beams are given on page 31.

**Spacing of Bars.** See Report of Joint Committee, page 149, and also page 77.

**Flexural Tests.** In making bending tests of beams, it is usual to place the equal loads on points dividing the length into three equal parts. The general arrangement is shown in Fig. 9. The advantage of this arrangement is that the bending



moment is practically uniform within the space between the loads. Measuring devices are attached so that the deformations of the fibers at the top and at the bottom, and the vertical deflection of the beam may be determined.

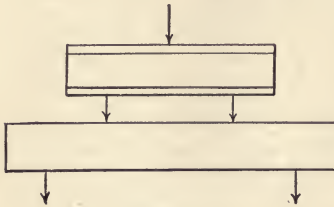

FIG. 9.

The objects in view in making flexural tests are, (a) to learn the facts concerning the first signs of failure; (b) to note the location and direction of cracks that finally produce failure; (c) to determine the conditions at the time of final or complete failure. When such information is at hand, formulas may be developed by means of which inferences may be drawn as to the probable strength of other unbroken beams.

**The Neutral Axis.** When a simple beam of homogeneous material bends, the upper fibers are in compression and the lower ones are in tension, while between them there is a neutral plane or axis. These facts give rise to the well-known bending equation

$$M = SI \div c$$

in which  $M$  is the moment of the external loads,  $S$  is the unit stress in the extreme fibers distant  $c$  from the center of gravity of the section, and  $I$  is the moment of inertia of the right section. When the beam is of such composite character as steel and concrete, the neutral plane is neither at the gravity axis of the section, nor does it remain fixed during the successive applications of varying loads. It is, then, of first importance that the position of the neutral axis be determined as accurately as may be. This is done by means of measurements of the deformations at the compression edge, and at plane of the reinforcing bars. If in Fig. 10 the deformations be  $aa'$  and  $bb'$  the neutral axis,  $o$ , is located by connecting  $a'b'$  with a straight line intersecting  $ab$  at  $o$ . The assumption that the plane section  $ab$  becomes the plane section  $a'b'$  after bending is called "Navier's hypothesis," or the assumption of the conservation of plane sections. Careful measurements show some deviation from a plane, but, in

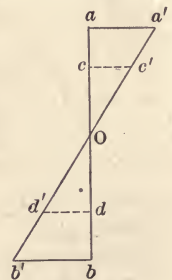

FIG. 10.



general, the above assumption seems to be warranted by the results of observed deformations under working loads. If observations be made at  $cc'$  and  $dd'$ , another determination of the neutral axis is made by joining  $c'd'$ . This was done in making the tests noted below from Bulletin No 1, page 29, University of Illinois Engineering Experiment Station. The points  $a$  and  $b$  were 11, and  $c$  and  $d$  were 6 inches apart.

Applied Load Pounds	Distance of Neutral Axis from Top. Inches		Applied Load Pounds	Distance of Neutral Axis from Top. Inches	
	By $a'b'$	By $c'd'$		By $a'b'$	By $c'd'$
1,000	10.0	7.7	12,000	6.95	6.6
2,000	8.5	7.35	14,000	7.05	6.75
3,000	7.85	7.9	16,000	7.2	6.9
4,000	7.65	7.4	18,000	7.3	7.0
5,000	7.05	7.2	20,000	7.65	7.5
6,000	7.2	6.75	22,000	7.95	7.7
7,000	7.0	6.75	23,000	8.1	7.9
8,000	7.0	6.6	23,600	8.15	7.9
10,000	6.9	6.55	—	—	—

This table shows a fair agreement in the two determinations of the neutral axis, since very minute errors of measurement produce appreciable differences in results. Also, lack of uniformity in the concrete has the same effect. The noticeable discrepancy between the two determinations for the 1000 pound load will be referred to later. The ultimate load for this beam was 24,600 pounds. If the safe working load be taken as  $\frac{1}{6}$  to  $\frac{1}{4}$  of the ultimate, or from 4000 to 6000, the two determinations do not differ widely.

In the above table the rapid change in position of the neutral axis under the light loads is noticeable. This rise of the neutral axis is shown in Fig. 11. Under light loads the concrete on the tension side is intact and acts with the steel, consequently the deformation of the steel is small, a large proportion of the section is

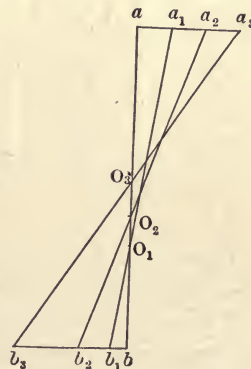

FIG. 11.

in compression, and hence the neutral axis is low, although not stationary. If the coefficient of elasticity be  $2,000,000 = E$ , and the ultimate strength of concrete in tension be  $S_t = 200$  pounds per square inch, the ultimate unit elongation of the concrete is .0001. When such loads have been applied as will cause a greater elongation, the concrete in tension becomes broken by fine, usually unnoticeable cracks, and the steel takes a greater part of the tensile stress. The elongation  $b_1b_2$  increases faster than  $a_1a_2$ , and the neutral axis rises rapidly. Additional loads cause more and deeper cracks in the concrete and a continued upward but slower movement of the axis. These two stages represent what takes place in a beam when carrying rather less than the safe working loads.

The action of a beam under ordinary working loads represents another stage during which the position of the neutral axis moves but little and the steel takes all the tension. The following table, taken from the same source as that above, shows the position of the neutral axis during this stage.

Beam No.	Per Cent. of Reinforcement	Proportionate Depth	Beam No.	Per Cent. of Reinforcement	Proportionate Depth
21	0.41	.34	14	1.11	.46
19	0.41	.36	5	0.83	.42
16	0.52	.375	28	1.52	.53
17	0.52	.37	13	0.97	.45
27	1.56	.53	20	0.69	.44
9	0.52	.34	2	0.69	.39
15	0.83	.41	7	0.42	.33
10	0.83	.43	3	0.42	.31
22	1.67	.57	29	1.48	.52
4	1.39	.47	—	—	—

Beam No. 22 in this table is the one from which the previous table was taken. It will be noted that the ratio of the area of the cross-section of steel to that of concrete was large; the consequence was that the final loads caused excessive stresses in the concrete while the steel was not stressed above its elastic limit. This represents the final, or failing stage, and the neutral axis is seen to fall. This final drop of the axis does not occur when the reinforcement is such that failure takes place first in

the steel. If the ultimate strength of the concrete in compression be  $Sc = 3000$  pounds per square inch, this fourth stage will be entered upon when the unit deformation becomes .0015 on the compression side.

In Fig. 12 are shown the three typical cases of beam failure. If the component parts of the beam were of the strengths assumed, the design might be such that the full strength in compression, tension, and shear would be reached at the same

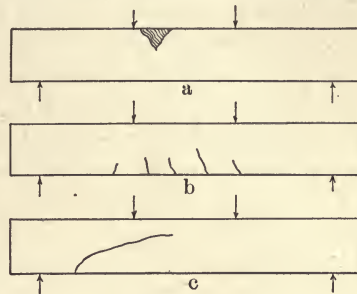

FIG. 12.

time. Such a condition is seldom realized in practice, but the three causes of failure may follow each other so closely that rupture may be attributed to the wrong one.

**Compression.** In *a* the proportion of steel is sufficient to develop the full strength of the concrete before itself is stressed beyond the elastic limit. Failure in this way takes place slowly, and, in actual use in buildings, ample warning is given that supports must be provided and repairs made. An area of steel cross-section from 1 per cent. to 1.5 per cent. of that of the beam will usually be sufficient to prevent failure by tension.

**Tension.** The cost of steel is often such in comparison with that of concrete that it is not economical to use enough of the former to develop the ultimate strength of the concrete in compression. Test beams then may show open cracks, as in *b*, Fig. 12, on the under side; they begin where the bending moment is large, the exact location being determined by the presence of a section weaker than others having the same or greater bending moments. Failure by tension occurs rapidly when the elastic limit of the steel is exceeded.

**Diagonal Tension.** The crack shown in *c*, Fig. 12, usually begins, in test beams with two loads, between one load and the nearer support, and continues upward and toward the middle of the span. This is a diagonal tension-failure, sometimes called shear, and is a combination of shear and tension which may cause rupture before the steel is stressed beyond its elastic limit or the concrete in compression is broken. Failure from this cause occurs in beams having a depth large in comparison with



the length, since in such cases a high vertical shear is developed. The unit diagonal tension in homogeneous beams is given by the formula  $t = \frac{1}{2}S + \sqrt{\frac{1}{4}S^2 + v^2}$ , in which  $S$  and  $v$  are the unit stresses due to horizontal tension and vertical shear respectively. The direction of the diagonal tension is expressed in  $\tan 2\theta = 2v \div S$  where  $\theta$  is the angle between the direction of the stress and the horizontal. At the neutral axis  $S$  is zero, and  $\theta$  reduces to  $45^\circ$ , while  $t$  becomes equal to  $v$ .

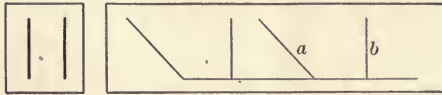

FIG. 13.

Diagonal tension is provided for by bending up the ends of the longitudinal bars that are not needed far beyond

the middle of the beam, and by the insertion of vertical rods or U-shaped forms called stirrups. The bent up rods are shown at  $a$  and the stirrups at  $b$ , in Fig. 13.

**Bond and Shear.** For ordinary loads and for beam sizes necessary to provide against other varieties of failure, shear is seldom a controlling factor in the design. If the area of cross-section of the steel be about  $\frac{3}{4}$  of 1 per cent. of that of the beam, the usual beam formula applies to reinforced concrete beams. As will be shown later, for homogeneous rectangular beams the maximum unit shear is  $\frac{3}{2}$  the average. Then, for uniform load, if  $C$  be the unit stress in the concrete and the neutral axis be in the middle,

$$C = 6M \div bd^2 = \frac{3}{4}wl^2 \div bd^2$$

and

$$v = \frac{3}{2}V \div bd = \frac{3}{4}wl \div bd$$

hence

$$v : C = d : l.$$

According to Table, page 18,  $v$  is more than half the compressive strength of concrete, so it is unlikely that a beam will break by direct shear. Of course the above assumptions as to the amount of reinforcement and load are not general, but under usual conditions the conclusion is correct. On page 79 it will be shown that  $l/d$  may be even less than  $C/v$  before the shearing strength is exceeded by the shearing stress.

The following table of bond and shear stresses in a beam is from Bulletin No. 4 University of Illinois Engineering Experiment Station. In the expressions for  $v$  and  $u$ ,  $j$  is the vertical distance from the center of gravity of the compressive stresses



to that of the tensile stresses. In a homogeneous beam,  $j = \frac{2}{3} d$ , making  $v = \frac{3}{2} V \div bd$  as used above. In a reinforced concrete beam,  $j$  is variable, depending upon the position of the neutral axis. The area of contact between a reinforcing bar and the concrete is  $o$ , and the number of bars is  $m$ .

Reinforcement %	Vertical shear $v = V \div b j$ Lb. per Sq. In.	Bond $u = V \div m o j$ Lb. per Sq. In.
2.21 mild steel	130	110
2.21 " "	124	106
2.21 " "	137	117
1.66 " "	120	135
1.66 " "	104	116
1.60 " "	117	143
1.84 " "	109	112
1.10 tool steel	95	161
1.10 " "	72	123
1.10 " "	66	112
1.10 " "	107	181
1.10 " "	73	124
1.10 " "	73	124
1.66 " "	101	114
1.66 " "	126	143
1.66 " "	107	120

The concrete was of 1:3:6 mixture. It will be noted the values of  $v$  are much smaller than the ultimate strength as given on page 18.

**Repetition of Stress.** It is well known that an enormous number of repetitions of a comparatively small load will cause fracture in a piece of metal capable of sustaining a static load many times as great. An account of experiments to determine the effect of repetition of loads on concrete is given in Trans. Am. Soc. C. E., Vol. LVIII. The summary is shown in Fig. 14.

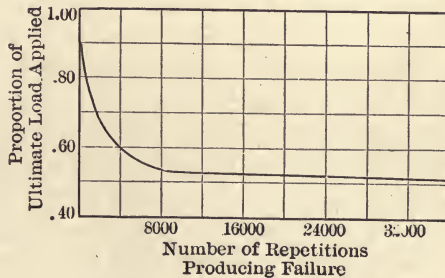

FIG. 14.

It is seen that when the load applied is, for example, 60 per cent.

of the ultimate, 4000 applications cause failure; when it is 55 per cent. about 8000 applications are required. If loads representing usual factors of safety, as 4 or 5, be considered, the number of repetitions required to cause failure is comparable with the number necessary in the case of iron.

In Engineering Record, Vol. 58, page 90, is an account of repeated loadings made at University of Pennsylvania on concrete beams. Under loads causing 25 per cent. of the ultimate stresses the set remained practically constant for 360,000 applications. The amount of set increased materially under heavier loads, and 500,000 repetitions of a 40 per cent. load did not seem to affect the ultimate strength of the beam.

Fig. 15 shows the stress-strain diagram of a beam as reported in Bulletin No. 14, Univ. of Ill. Engineering Experiment Station.

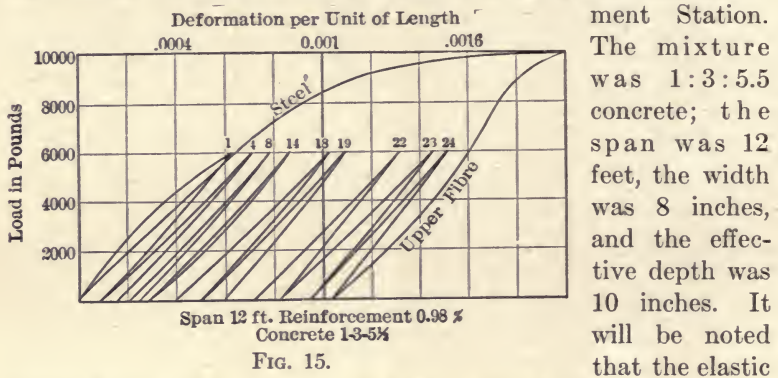

The mixture was 1:3:5.5 concrete; the span was 12 feet, the width was 8 inches, and the effective depth was 10 inches. It will be noted that the elastic

deformation remained quite constant throughout.

**Expansion and Contraction.** In structures containing extended areas of concrete, allowance must be made for expansion and contraction, which occur from two causes. Like most building material, concrete expands as the temperature rises, and contracts as it falls. Experiments made to determine the rate of change in length of concrete due to change of temperature have not been as numerous or as conclusive as could be desired. However, the tests seem to indicate that the coefficient of expansion is between .0000055 and .0000065, and that the mean of these may be accepted as the average value. The coefficient of expansion of steel is .0000065 to .0000067, which is so nearly like that of concrete that only small stresses result from the difference.

Concrete, in hardening under water, expands somewhat, usually from .0002 to .0005 of its length, while it contracts from .0003 to .0005 of its length if kept in air. For the same mixture the change in air is generally more marked, and as between different mixtures, the richer suffers the greater changes. These changes may continue slowly for months, but about half the whole will be effected in perhaps a week. As most reinforced concrete structures are built within forms that retain, for one or two weeks, some of the extra water used in mixing, the expansion or contraction should often not be more than the smaller values given above.

Cracks are sure to appear unless they are uniformly distributed by means of reinforcing metal, or contraction joints are provided wherein the contraction may take place without being noticeable. The unsightly appearance of a wall cracked by contraction in the concrete should be a sufficient reason for the prevention of the same, but the stability of the structure may be endangered if the openings allow entrance of water or moisture in sufficient quantities to cause the steel to rust.

**Weight of Reinforced Concrete.** Experiments to determine the weight of concrete, made at the Watertown Arsenal, are published in "Tests of Metals," 1897-99 and 1903-4. The conclusions are that dense, well made 1:2:4 concrete, when dry, weighs 110, 145, 150, 152, and 155 pounds per cubic foot, according as the aggregate is cinder, sandstone, limestone, gravel, or trap rock. A 1:3:6 concrete of trap weighs 150, of gravel, 145, and of cinder, 105 pounds per cubic foot. One per cent. of steel adds about 3.5 pounds to these weights.

The assumed weight\* of reinforced concrete is usually 150 pounds per cubic foot.

**The Reinforcing Metal.** Most of the steel used as reinforcement is in the form of bars of round or square cross-section. Flat shapes do not effect as reliable bond, otherwise they would have some advantage over the square section in that the centers may be placed farther from the neutral axis. Various bars of deformed cross-section, designed to secure mechanical bond, are widely advertised. Many of these shapes are popular and effective, and are sold at prices not much above plain bars. Woven wire and thin plates, punched so as to secure a bonding section, are used in thin slabs with good effect. The sizes of



bars vary by  $\frac{1}{8}$ -inch increments, from  $\frac{1}{4}$  inch to an inch, and then by  $\frac{1}{8}$ -inch increments, to  $1\frac{1}{2}$ -inch diameters. Occasionally 2-inch bars are used, but they are bent with some difficulty.

**Qualities of Steel.** Specifications for reinforcing steel are given on page 155. In general such steel is of two varieties, "medium steel" and "high elastic limit steel." A comparison between the two is shown below.

	Ultimate Tensile Strength	Elastic Limit	Elastic Deformation
	Pounds per Square Inch		Per Unit of Length
Medium steel	60,000 to 70,000	35,000 to 40,000	0.0010 to 0.0013
High elastic limit steel	80,000 to 100,000	50,000 to 60,000	0.0015 to 0.0020

The coefficient of elasticity of steel is assumed to be 30,000,000 pound inches. The coefficient of expansion of steel is usually taken at .0000065 for each degree Fahr. of change of temperature.

For other specifications for steel see report of Committee A-1 to the American Society of Testing Materials, June 28, 1911. This report was approved by the meeting for submission to letter ballot.

**Proportioning Concrete.** The exact amounts of cement, sand, and broken stone necessary to make a cubic yard of concrete have not been definitely determined. The reason is that so many factors, such as sharpness of sand and of pieces of the aggregate, percentage of voids in the same, dampness of the sand, manner of packing, and measuring the cement and amount of water used, make a concise statement impossible. A valuable article, with discussions, on the effect of varying the proportions in concrete, is published in Trans. Am. Soc. C. E., Vol. LIX, December, 1907.

**Quantities Required for a Cubic Yard of Concrete.** The table below is from various sources, and is supposed to represent common practice when cement is measured by bags of 96 pounds, and loose sand and run of crusher broken stone are used.



Proportion by Parts	Volumes in a Cubic Yard of Concrete			Volumes of Sand and Stone to a Unit of Cement		
	Cement, Bbl.	Sand, Cu. Yd.	Stone, Cu. Yd.	Cement, Bbl.	Sand, Cu. Ft.	Stone, Cu. Ft.
1:2:3	1.65	0.45	0.70	1	7.6	11.4
1:2:4	1.40	0.40	0.80	1	7.6	15.2
1:2:5	1.20	0.35	0.85	1	7.6	19.0
1:3:5	1.10	0.50	0.75	1	11.4	19.0
1:3:6	1.00	0.45	0.85	1	11.4	22.8
1:3:8	0.80	0.35	0.90	1	11.4	30.4
1:4:8	0.75	0.40	0.85	1	15.2	30.4

The sand and broken stone are often measured by the wheelbarrow load, in which case a box containing a cubic foot should be frequently used to verify the loads.

**Fuller's Rule.** A simple rule is proposed by Mr. W. B. Fuller, which gives fairly accurate proportioning for packed cement, sand, and broken stone that has about 40 per cent of voids. Let  $c$ ,  $s$ , and  $g$  be number of parts of cement, sand, and gravel or broken stone respectively. Let  $C$ ,  $S$ , and  $G$  be the number of barrels of packed cement, the number of cubic yards of loose sand and gravel or broken stone respectively, required for a cubic yard of concrete, then

$$C = \frac{11}{c + s + g}$$

$$S = C \times s \times \frac{3.8}{27}$$

$$G = C \times g \times \frac{3.8}{27}$$

If stone be screened to uniform size add 5 per cent., and, for well-graded stone, deduct 5 per cent. from all quantities.

**Depth of Concrete below Steel.** There are two reasons for covering the rods in the tension side of a beam with concrete: without this covering the bond would be imperfect; and by it protection is given from fire and from moisture. The recommendations of the Joint Committee (p. 144) are that the thickness of the concrete outside the rods be: for slabs, 1 inch; for beams,  $1\frac{1}{2}$  inches, and for girders, 2 inches.

## PROBLEMS

2. Compute the number of cubic yards in a concrete pier 4 feet by 16 feet on top and 22 feet high. The four sides have a batter of an inch to the foot.
3. Compute the amount of cement, sand, and broken stone required to build the pier in Problem 2, the mixtures being 1:2:5, 1:3:6, and 1:4:8.
4. With cement at \$1.65 a barrel, sand, \$0.75, and broken stone, \$1.50 per cubic yard, which of the mixtures in Problem 3 is the cheaper if the strength according to Table, page 16, be considered?

## CHAPTER IV

### ANALYSIS OF STRESSES

**Stresses in Beams.** Any beam, whether homogeneous or otherwise, will, when loaded, be stressed in tension, compression, and shear. The horizontal tension and compression stresses unite with the vertical shear to produce resultant diagonal tension and diagonal compression stresses. In beams of material that has about equal tensile and compressive strength, the diagonal stresses are not so vital as in concrete beams. These stresses will be considered in order.

**Beam Theories.** Navier's hypothesis pertains to beams of all materials, and, as explained in page 26, holds good for working loads on those of concrete. In homogeneous beams, where the tensile and compressive elasticities are alike and Hooke's law applies, the stress diagram is like Fig. 16, where  $a'b'$  is a straight line, and  $o$  is in the middle of  $ab$ .

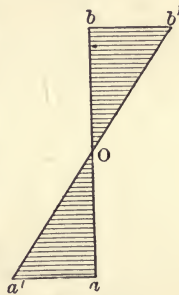

FIG. 16.

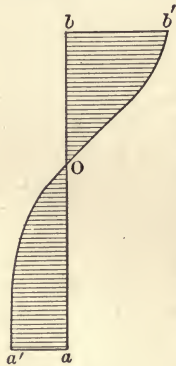

FIG. 17.

When concrete is stressed above safe limits, as the coefficient of elasticity of concrete is not constant for all stresses, the stress diagram is not bounded by straight lines as before, but is represented by Fig. 17. For equilibrium the areas  $obb'$  and  $oaa'$  must be equal, so, if  $aa'$  is smaller than  $bb'$ , the neutral axis is above the middle. The stress is not proportional to the deformation, and if computed by the ordinary beam formula, or from measured deformations with the assumption that  $a'b'$  is straight, high values of modulus of rupture will be obtained as was shown on page 27.

When steel is introduced to take tension in the beam, it is capable of much greater elongation without breaking than is concrete. For this reason the concrete on the tension side is

broken at frequent intervals, the cracks extending inward toward the neutral axis. While they do not reach quite to that plane, the tensile strength of the concrete is so nearly destroyed before the safe working strength of the steel is developed, that it is usual to assume the steel taking all the tension. The cracks are most numerous and deepest where the bending moments are greatest or where the concrete happens to be weakest. The concrete may be intact and able to resist shear and diagonal tension near the ends of the beam where the shear is greatest.

Fig. 18 shows the stress diagram on the left where the line  $cc'$  represents the ultimate compressive strength, and  $bb'$  the stress under any given loading. If  $c$  and  $s$ , in Fig. 18  $b$ , be

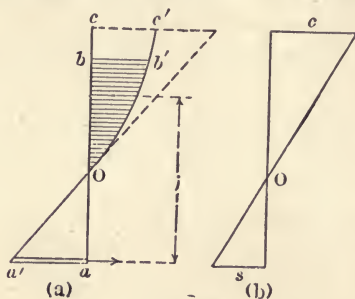

FIG. 18.

nature of the curve  $ob'c'$  will be known if a sufficient number of points, as  $b'$ , be fixed.

For working stresses, as  $bb'$ , Fig. 18, the line  $ob'$  may be taken as straight without material error in results.

For loads that cause the destruction of a beam, the straight line assumption certainly does not hold true. Repeated observations of the stress diagrams indicate that  $ob'c'$  is very nearly a parabola whose origin is at  $c'$  when  $cc'$  is the ultimate strength of concrete. There may be some curve that fits the plotted points even better than does the parabola; but no other as simple and well known curve seems available. Hence, the parabolic stress diagram for ultimate loads is universally adopted in analyzing the stresses in beams tested to destruction.

**The Straight Line Analysis.** In the following pages the nomenclature is as given below, unless otherwise stated.

$l$  = length of beam.

$b$  = breadth of beam.



$d$  = distance from center of tensile steel area to compression side of beam, or the effective depth.

$h$  = entire depth of beam.

$A$  = area of tensile steel in section considered.

$A'$  = area of compressive steel in section considered.

$p = A \div bd$  = proportion of steel, in section.

$p = A \div bh$ , when the whole section is in compression.

$k$  = distance of neutral axis from compressive side.

$S_t$  = tensile unit stress in the steel.

$S_c$  = compressive stress in the steel.

$C$  = compressive stress in the concrete.

$r = S_t \div C$ .

$r' = S_c \div C$ .

$E_s$  = coefficient of elasticity of steel.

$E_c$  = coefficient of elasticity of concrete.

$s$  = unit elongation of steel.

$c$  = unit elongation of concrete.

$n = E_s \div E_c$ .

$M$  = bending moment due to loads.

$N_1, N_2$ , etc., = constants in stress formulas.

$V$  = vertical shear.

$v$  = unit shearing stress.

$I$  = moment of inertia with respect to gravity axis.

$j$  = vertical distance between points of application of horizontal tensile and compressive stresses.

$b'$  = breadth of web of T-beam.

$t$  = depth of slab of T-beam.

lb. sq. in. = pounds per square inch.

lb. in. = product of pounds by inches.

Fig. 19 represents the stresses in a beam due to bending. For equilibrium the sum of all horizontal forces is zero, so

$$AS_t = \frac{1}{2} bCk \quad (3)$$

Since the sum of all the moments is zero

$$AS_t(d - k) + \frac{1}{3} bCk^2 = M \quad (4)$$

Since a plain section remains plain after bending

$$\frac{d - k}{k} = \frac{S_t}{E_s} \div \frac{C}{E_c} = \frac{S_t E_c}{C E_s} \quad (5)$$

$$\text{or} \quad k = \frac{dn}{r + n} \quad (6)$$

$$\text{From (6) and (4)} \quad A = \frac{bdn}{2r(r+n)} = \frac{3(n+r)M}{dS_t(3r+2n)} \quad (7)$$

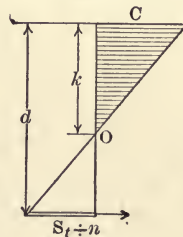

FIG. 19.

$$p = \frac{n}{2r(n+r)} \quad (8)$$

From 6 and 8,  $k = 2pr d$  (9)

Putting the value of  $r$  in (8) into (9)

$$k = d(-np \pm \sqrt{2np + n^2p^2}) \quad (10)$$

The positive sign of the radical is to be used.

From (7)

$$j = d \frac{3r + 2n}{3(r+n)} \quad (11)$$

$$= d \left( 1 - \frac{2pr}{3} \right) \quad (12)$$

since in Fig. 19,  $j = d - \frac{1}{3}k$ .

An expression for the depth is obtained by solving (7) for  $d$

$$d = \frac{3(n+r)M}{AS_t(3r+2n)} \quad (13)$$

Substituting the first value of  $A$  in (7)

$$d = \frac{6r(r+n)^2 M}{bnS_t(3r+2n)} \quad (14)$$

Since  $S = rC$

$$d = \frac{6(r+n)^2 M}{bnC(3r+2n)} \quad (15)$$

From which

$$\begin{aligned} M &= \frac{1}{6} bd C n \frac{3r+2n}{(r+n)^2} \\ &= N_1 C b d^2 \end{aligned} \quad (16)$$

When  $N_1$  is  $\frac{1}{6}$  this becomes the ordinary beam formula,  $M = SI \div c$ , where  $c$  is the distance from the gravity axis to the extreme fiber.

In Plate 1 are plotted values of  $N_1$  for three values of  $n$ . Crossing these curves are lines representing values of  $p$  taken from equation (8), while values of  $r$  are given by abscissas.

It will be noted that of the factors involved,  $N$ ,  $r$ ,  $p$ , and  $n$ , only two may be arbitrarily assumed at once, as the others are dependent upon these. For example, if  $S$  be 15,000 and  $C$  be

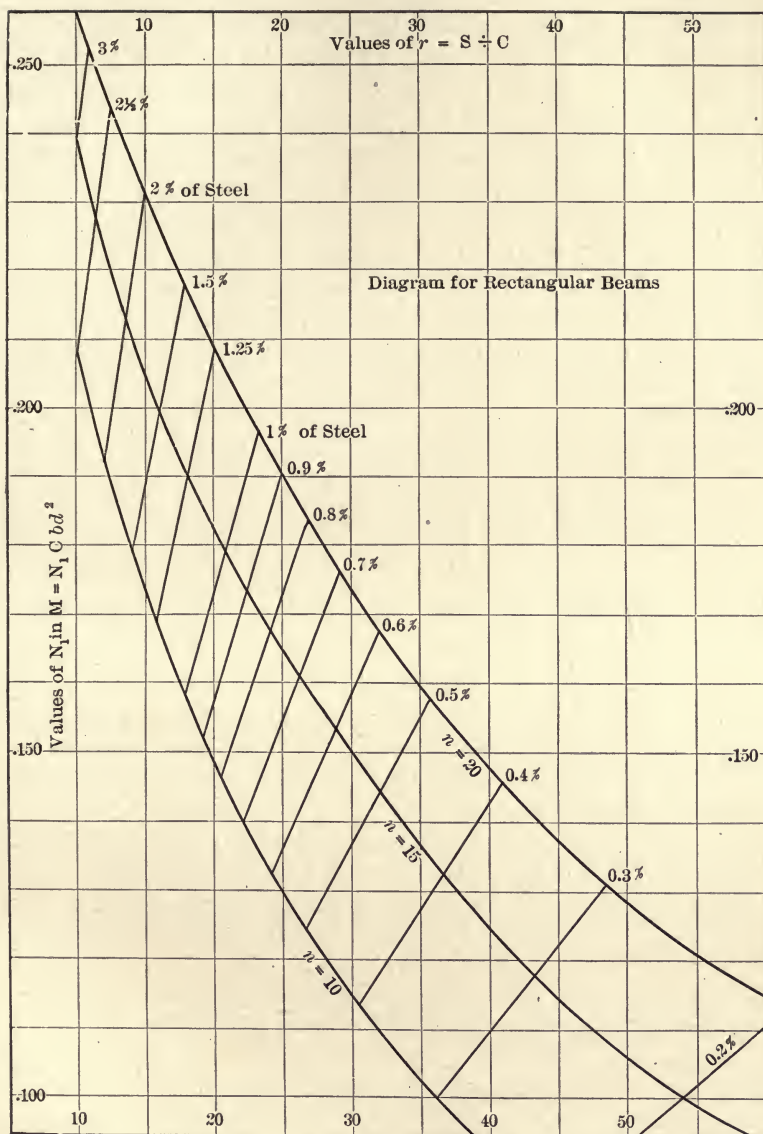

PLATE I.

500 pounds per square inch,  $r$  is 30; then if  $n$  be 15,  $p$  and  $N$  are 0.0056 and 0.148, and cannot be otherwise assumed.

Again, if the loads  $p$  and beam dimensions be known, for usual limits of  $n$  (10 to 20),  $N_1$  must be between 0.123 and 0.157, while  $r$  will lie between 27 and 36; and if these values, with a safe working stress for  $C$ , give  $M$  less than that computed from the loads, the beam is overloaded or too small. For example, a beam is 12.5 feet long,  $b = 12$  inches,  $d = 18$  inches, and  $p$  is .008. If the concrete be of good quality the value of  $n$  may be taken as 15. It is required to find the safe load per linear foot for this beam. In the diagram, for  $n = 15$  and  $p = .008$ ,  $N_1$  is .167, and  $r$  is 24. If the concrete be capable of sustaining a stress of 600 pounds per square inch, the steel should carry  $600 \times 24 = 14,400$ , as it usually can. With these assumptions

$$\begin{aligned} M &= .167 \times 600 \times 12 \times 18^2 \\ &= 398570 \text{ lb. in.} \\ 12 \times 1/8 w l^2 &= 21640 \\ w &= 1730 \text{ pounds per linear foot.} \end{aligned}$$

**Excessive Reinforcement.** As a general proposition it is not economical to use a greater amount of steel than is indicated by the intersection of the ordinate through  $r$  and the curve of  $n$  in Plate I. For example, let the safe strength in pounds per square inch of steel and concrete be respectively 16,000 and 500, and let the percentage of steel be 1.0. According to the diagram, considering  $p$  and  $n$ ,  $r$  is 21, and hence, if  $C$  be 500,  $S_t$  is only 10,500. The difference between 16,000 and 10,500 is paid for, but is not used unless 500 for  $C$  be exceeded. The value of  $N_1$  is seen to be .180, and the bending moment is

$$M = .180 \times 500 \times b d^2$$

For the assumed values of  $C$  and  $S_t$ ,  $r = 32$  and  $N_1$  is .144

$$\text{or} \quad M = .144 \times 500 \times b' d'^2$$

To make these values of  $M$  identical,  $d'^2$  may be changed in the ratio of .180 to .144, and the new area of cross-section will be 1.12 of the first, while but half as much per cent. of steel is



needed. The cost of the two designs would then be indicated by

$$1.00 bdx + .01 bdy$$

and

$$1.12 bdx + .0056bdy$$

when  $x$  is the cost of concrete and  $y$  that of the steel. If the steel be worth 50 times as much as concrete per unit of volume, the beam with 1 per cent. of reinforcement costs 1.07 as much as that with  $\frac{1}{2}$  per cent. reinforcement, greater depth and the same strength.

The questions of economical design will be taken up again in Chapter V, but this example serves to illustrate the fact that the strength of a beam depends largely upon its depth.

**Under Reinforcement.** Assuming the same values of  $C$  and  $S$  as above, makes  $r = 32$  and  $p = 0.5$  per cent. If the beam be constructed with but .25 per cent. of steel,  $r$  will be about 48. If  $S_t$  be 16,000,  $C$  must be  $16,000 \div 48 = 333$  pounds per square inch. On the other hand, if 500 pounds unit stress be developed in the concrete, the steel will be carrying a unit load of 24,000 pounds. Hence, if it be desired to adhere strictly to the assumed safe unit stresses,  $p$  must be exactly as given in the Plate I.

### PROBLEMS

5. A simple beam 12 inches by 16 inches by 18 feet carries two loads of 2000 pounds each, at 4 feet and 9 feet from the end, in addition to its own load. What percentage of steel is required that the unit stress in the concrete be not over 550 pounds per square inch? What will be the unit stress in the steel?

6. A simple beam of 1:3:6 concrete has a span of 16 feet. If the width be 10 inches and  $p$  be 6 per cent., what should be the depth to sustain a uniform load of 800 pounds per linear foot? What should  $h$  be? What change in depth and of  $p$  would be allowable if a 1:2:4 concrete be used?

7. If the reinforcement in Problems 5 and 6 be of three-quarter inch square bars, how far from the middle of the beams is it necessary that all these bars extend to provide for the bending moment?

8. If 2.1 square inches of steel be required in a breadth of 12 inches, what size of round bars may be used to most nearly conform to the rules given on page 150, and to the assumed area?

**Extending Plate I.** It may happen that a larger scale is desired for this plate, or that it is to be used for a concrete of

cinders for which  $n$  may be as high as 30. In (8), if  $p$  and  $n$  be assumed a value of  $r$  can be found. With this value of  $r$   $N$  is found from (15). For example, let it be required to find the intersection of  $p = 1$  per cent. and  $n = 30$ . From (8)  $r$  is found to be 26.5, and from (15)  $N$  is 0.219. In like manner points on the lines indicating the values of  $p$  are plotted and all are connected by a smooth curve.

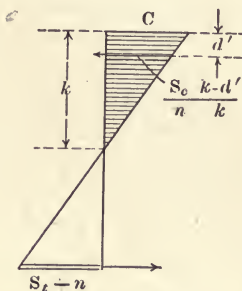

FIG. 20.

**Double Reinforcement.** Instead of increasing the depth to procure more strength, it is sometimes expedient to add steel on the compressive side. In Fig. 20 compressive steel of  $A'$  is  $d'$  from the top. For equilibrium

$$\frac{bCk}{2} + A' \left( S_c - C \frac{k - d'}{k} \right) = AS_t \quad (17)$$

and giving to  $AS_t$  this value, or taking center of moments at the tensile steel,

$$M = \frac{bCk}{2} \left( d - \frac{k}{3} \right) + C \left( A'r' - A' \frac{k - d'}{k} \right) (d - d') \quad (18)$$

as a vertical section remains plane during bending

$$k = \frac{dn}{r + n} = \frac{d'n}{n - r'} \quad (19)$$

and

$$r = \frac{d}{d'} (n - r') - n \quad (20)$$

Substituting these values of  $k$  and  $r$  in (18),

$$\begin{aligned} M &= Cbd^2 \left( \frac{3r + 2n}{6(r + n)^2} n + p'r' \frac{n - 1}{n} \cdot \frac{d - d'}{d} \right) \\ &= Cbd^2 \left( N_1 + p'r' \frac{n - 1}{n} \cdot \frac{d - d'}{d} \right) \end{aligned} \quad (21)$$

$$= N_2 Cbd^2 \quad (22)$$

It will be noted that (22) and (16) are identical when  $p'$  is zero.

In (18)  $A$  and  $A'$  may be stated in terms of  $p$  and  $p'$  whence

$$p = \frac{k}{2dr} + \frac{p'r'}{r} + \frac{p'(k - d')}{rk}$$

and, substituting the value of  $k$ , above

$$p = \frac{n}{2r(n+r)} + p'r' \frac{n+1}{nr} \quad (23)$$

From the two values of  $k$  the relation between  $r$  and  $r'$  is given in (20) and plotted in Plate II. The values of  $N_1$  are taken from Plate I, and curves of  $N_2$  are plotted from assumed values of  $p'$ ,  $r'$ ,  $n$ , and  $d' \div d$ . The reinforcement is seldom more than  $\frac{1}{10}d$  from the edge, and the plate is made with this assumption. If the steel be nearer than  $1/10d$  from the edge, the error is on the safe side.

In case  $d'$  is not  $d \div 10$  the diagram may still be used. In (21) it is seen that  $d'$  appears only in  $(d - d') \div d$ , and so  $N_2$  is readily changed to suit any value of  $d'$ . For example, let  $d'$  be  $2/10d$ , then the ordinate in Plate II between the curve of  $p' = 0$ , and that of any other value of  $p'$  will be  $8/9$  of that given in the diagram. If  $p' = 1$  per cent. and  $p = 1\frac{1}{2}$  per cent., the ordinate between the curves for  $p' = 0$  and  $p' = 1$  per cent. is  $0.268 - 0.200 = 0.068$  when  $d' = 1/10d$ . If  $d' = 2/10d$  the ordinate will be  $8/9 \times 0.068 = 0.06$ , and  $N_2 = 0.200 \div 0.06 = 0.260$ , instead of  $0.268$  as given in the diagram.

It will be seen that the factors  $S_t$ ,  $S_c$ ,  $C$ ,  $p$ , and  $p'$  are not independent of each other. If the bending moment be fixed and the dimensions of the beam be assumed, or otherwise determined, the amount of both tensile and compressive steel is dependent upon the unit strength assigned to either the concrete or to the metal.

For example, let the allowable unit stresses per square inch be  $S_c = S_t = 15,000$ , and  $C = 600$ . Let  $b = 16$  inches,  $d = 20$  inches,  $p = 2\frac{1}{2}$  per cent., and  $p' = 1$  per cent. In the diagram  $N_2$  is  $0.305$ , so the allowable bending moment is, in pounds per square inch,

$$M = .305 \times 600 \times 16 \times 400 = 1,171,000.$$

The intersection of  $p$  and  $p'$  is on the vertical through  $r$  and  $r'$ , which in this case are  $15$  and  $12$  respectively, so  $S_t = 9000$  and  $S_c = 7200$  pounds per square inch. These values are well within the safe limits set above.

In the last example, let it be required to determine the amount



of tensile steel sufficient to develop the given strength of the concrete and the compressive steel. The value of  $r$  is  $15,000 \div 600 = 25$ , and the ordinate through  $r = 25$  intersects  $p' = 1$  per cent. in  $p = 1.25$  per cent.  $N_2$  is .255, and  $b$  and  $d$  may be varied to suit the loads. For  $d' \div d = .1$  in (20),  $r$  and  $r'$  are equal when each is 12.27, and it is seen that, for most combinations of  $p$  and  $p'$ , this condition is not realized.

Let it be required to find  $b$  and  $d$  when the length is 20 feet,  $w$  is 600 pounds per linear foot, allowable unit stress in concrete and steel 500 and 16,000 lb. sq. in.,  $p = 1.5$  per cent., and  $p' = 1.0$  per cent. The weight of the beam itself must be added to  $w$ . The value of  $N_2$  is seen to be 0.270, so  $M = \frac{1}{8}(w + w_1) 20^2 \times 12 = .270 \times 500 bd^2$ . If the weight of the beam be assumed, as nearly as can be, at 200 pounds per linear foot,  $M = 480,000$  and  $bd^2$  is 3560. If the breadth be taken as 10 inches,  $d$  is 18.9 inches. If two inches be added below the steel, the area of cross-section is 209 square inches, and the weight per linear foot is 219 pounds. By recomputation, the depth is found to be 21 inches.

**Effect of Compressive Steel.** Inspection of Plate II shows that a beam of certain strength may be had by many different combinations of upper and lower reinforcement. For example,  $N_2$  is 0.200 when the percentages are: 0, 1.5; 0.35, 1.0; 0.63, 0.75; and 1.2, 0.5. The former combination gives the higher stresses in the compression steel as compared with those in the tensile reinforcement. By running across the page in this way on any given value of  $N_2$ , taking the sum of  $p$  and  $p'$  at each intersection, it will be seen that these sums have a certain minimum value, which combination is the one to be chosen for economy of steel. In this example the sums are: 1.5; 1.35; 1.38, and 1.7, of which, of course, the second is the minimum. This does not always mean that a beam, so constructed, would be cheaper than the one having no compressive steel, because the cost of putting in place two rows of bars instead of one is apt to be an important factor.

The projection of the curves of  $p$  and  $p'$  on the vertical shows the change in  $N_2$  due to changes in amounts of steel. With no compressive steel the increase in  $N_2$  between  $p = .005$  and  $p = .025$  is  $.228 - .142 = .086 = 60$  per cent. With  $p = 0.005$  the increase in  $N_2$  due to the addition of 2.5 per cent. of com-



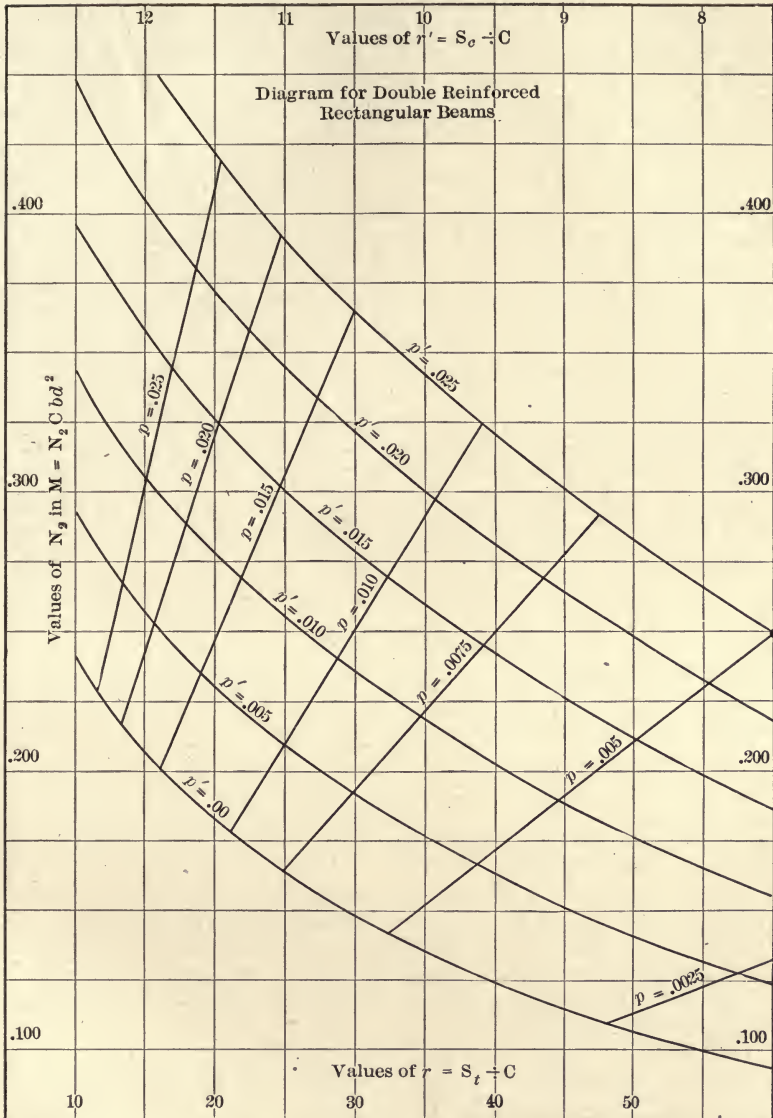

PLATE II.

pression steel is  $.250 - .142 = .108 = 76$  per cent. The application of this principle is seen in the following example.

If, with  $p = 1.5$  per cent. and  $p' = 0.5$  per cent.,  $C$  be 800, what change in  $p'$  is necessary to reduce this to 600 pounds per square inch? If  $M$  be constant, a change in  $C$  involves a corresponding change in  $N_2$ , which, in this case, is to be 25 per cent.  $N_2$  for  $p = 0.015$  and  $p' = 0.005$  is 0.235, which must be increased 25 per cent. in order to decrease  $C$  in like proportion, or  $N_2$  must be  $0.235 \times 1.25 = 0.294$ . Then the value of  $p'$  is 0.0145. If  $p' = 0.005$  be unchanged it will be necessary to make  $p$  something beyond the limits of the figure, or about 0.035. The first change is evidently the better, as less total steel is thus required.

The corresponding changes in  $S_t$  and  $S_c$  are easily found; in the first assumption above,  $r$  was 19 and  $r'$  was 11.6, hence,  $S_t = 800 \times 19 = 15,200$ , and  $S_c = 800 \times 11.6 = 9280$  lbs. per sq. in. In the second case  $r$  and  $r'$  were 24 and 11.1 respectively, and so the values of  $S_t$  and  $S_c$  became  $600 \times 24 = 14,400$  and  $600 \times 11.1 = 6660$  lbs. per sq. in. respectively, the decrease being 5.2 per cent. and 28.5 per cent.

### PROBLEMS

9. What is the per cent. of error if the bending moment be computed without allowing for the concrete displaced by the compression reinforcement? Assume  $p$  and  $p'$  each 1 per cent.

10. A simple beam has  $b = 12$  inches,  $d = 20$  inches,  $\frac{d'}{d} = \frac{1}{6}$ ,  $p = 2$  per cent.,  $p' = 1$  per cent., and working strengths of steel and concrete as 15,000 and 500 pounds per square inch. What is the safe resisting moment of the beam?

11. Let the beam in Problem 10 be subjected to a bending moment of 400,000 lb. in. Compute the working stresses in  $S_t$ ,  $S_c$ , and  $C$ .

12. If, in Problem 10, the compressive steel be removed, what increase in  $d$  will be necessary to maintain the strength of the beam unchanged?

13. What must be the value of  $p'$  that  $C$  be changed to 600 lb. per square inch in Problem 10?

14. In Plate II plot the curves of  $p = .006$ ,  $.008$ , and  $.0175$ .

15. In Plate II plot a curve representing the sums of  $p$  and  $p'$  for  $N_2 = .250$ , and so determine the minimum amount of steel necessary.

**Stresses in T-beams.** In beams of rectangular cross-section the concrete below the neutral axis serves only to transfer the

stress in the steel and does not possess tensile strength. Hence, considering only tension and compression, about half of the concrete is inert. The T-beam is designed to economize in this respect by concentrating the concrete, where it is most effective, near the compressive side of the beam.

If, in Fig. 21, the neutral axis falls within the flange, the analysis of stresses is the same as for rectangular beams. The value of  $k$  is  $dn \div (r + n)$ , as before, but if this be larger than the thickness of the flange,  $t$ , the following method is to be used. The ratio of

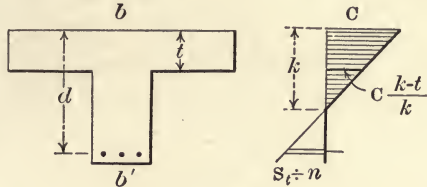

FIG. 21.

steel cross-section to that of the concrete is  $A \div bd = p$ , rather than  $A$  divided by the actual cross-section of the beam. The value of  $j$  is

$$j = d - \frac{3 dn - 2 t (r + n)}{6 dn - 3 t (r + n)} t \tag{24}$$

As the sum of the horizontal stresses is zero,

$$\frac{bCk}{2} - (b - b') C \frac{(k - t)^2}{2k} = AS_t \tag{25}$$

then

$$k = \frac{2 dnA + bt^2}{2 nA + 2 bt} \tag{26}$$

Since the sum of the moments is zero,

$$M = \frac{bCk^2}{3} + \left( \frac{bCk}{2} - (b - b') \frac{C (k - t)^2}{2k} \right) (d - k) + (b - b') C \frac{(k - t)^3}{3k} \tag{27}$$

$$\begin{aligned} &= \frac{bCk^2}{3} + \frac{bCk}{2} (d - k) - (b - b') \frac{C (k - t)^2}{2k} (d - k) \\ &\quad + (b - b') C \frac{(k - t)^3}{3k} \\ &= bC \left( \frac{dk}{2} - \frac{k^2}{6} \right) - (b - b') C \\ &\quad \frac{3k^2d - 6ktd + 3dt^2 - k^3 + 3kt^2 - 2t^3}{6k} \end{aligned} \tag{28}$$

Substituting the value of  $k = dn \div (r + n)$ , and making  $t = dx$ ,

$$M = bd^2 C \left( \frac{3r + 2n}{6(r+n)^2} n \right) -$$

$$(b - b') d^2 C \left( \frac{3r + 2n}{6(r+n)^2} n - x + x^2 \frac{r + 2n}{2n} - x^3 \frac{r + n}{3n} \right) \quad (29)$$

The first term is recognized as being  $N_1$  in (16).

This formula is usually applied to T-beams, in which  $b'$  is small as compared with  $b$ , and little error results if  $b'$  be dropped from the formula, since only that part of the web above the neutral axis is effective. With this approximation Plate III is constructed from

$$M = bd^2 C \left( x - x^2 \frac{r + 2n}{2n} + x^3 \frac{r + n}{3n} \right) \quad (30)$$

$$= N_3 bd^2 C \quad (31)$$

The extent of inaccuracy involved will be explained below, page 53.

The outer curve in Plate III is the same as that for  $n = 15$ , in Plate I, except that the scale is changed. The curves for various values of  $t$  end in the outer one in points beyond which values of  $p$  and  $r$  indicate that the neutral axis is in the flange of the beam, and the stresses are the same as though the section were rectangular.

Let the T-beam have:  $b = 36$  inches;  $d = 20$  inches;  $t = 4$  inches;  $b' = 10$  inches, working strengths of concrete and steel 600 and 15,000 lb. sq. in., and let the reinforcement be six  $\frac{3}{4}$ -inch bars. It is required to determine the safe resisting moment of the beam. The percentage of reinforcement is  $6 \times 9/16 \div 36 \times 20 \times 100 = .47$ , and, from the diagram,  $N_3 = 0.125$  and  $r = 37$ . With this value of  $r$  the full strength of the concrete cannot be utilized, as  $600 \times 37$  far exceeds the safe stress in  $S_c$ , so the working stress in the concrete is  $15,000 \div 37 = 405$  lb. sq. in. Then  $M = 0.125 \times 36 \times 400 \times 405 = 729,000$  lb-in.

The failure of T-beams is usually due to lack of sufficient steel rather than to compression of the concrete. Very often the flange is a part of a slab forming a floor, and it is impossible to know how wide to assume the beam. In the above example, if  $b = 22.3$  inches,  $p$  is .76 per cent. and  $r$  is 25, as the allowable stresses indicate. According to adopted practice (see page 148)



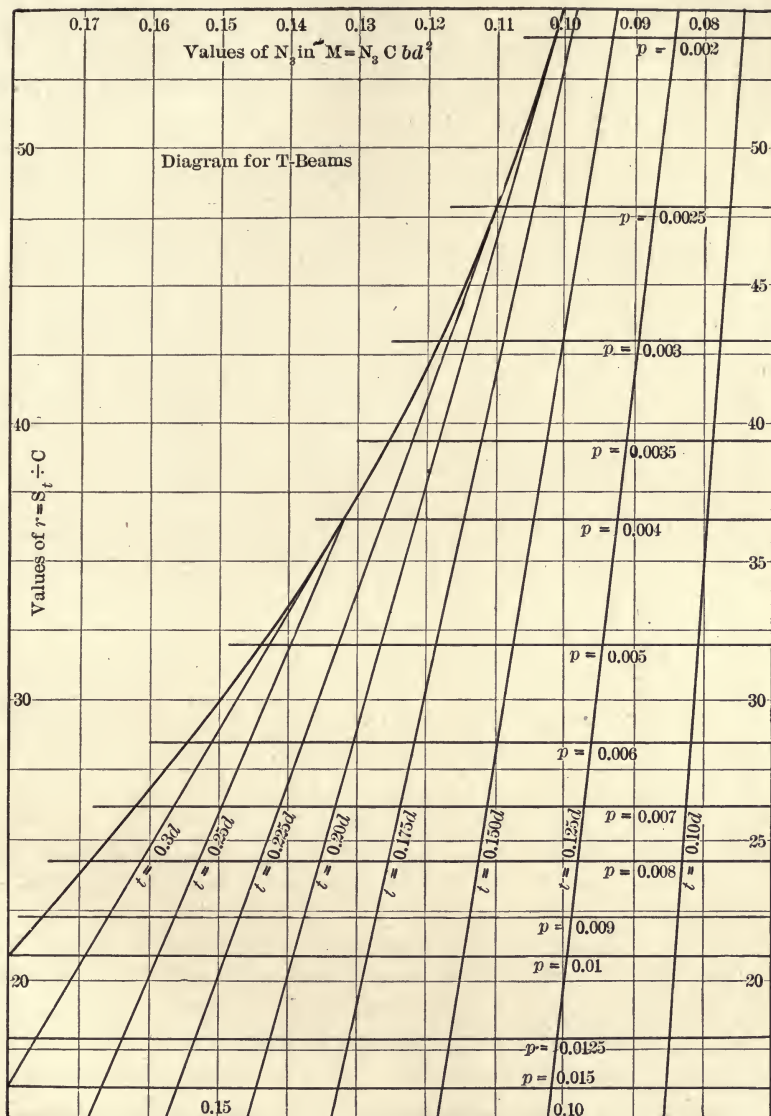

PLATE III.

the flange width might be as much as 42 inches. With such an assumed width the compressive strength of the concrete is seldom developed.

**Tests of Reinforced Concrete T-beams.** The tests given in the following table have been made recently and are by the most reliable investigators.

TABLE OF TESTS OF T-BEAMS

No.	Mixture	Age Days	Horizontal Reinforcement %	Web Reinforcement Rods	Flange Inches		Web Inches		Load Lbs.	Stress. Lbs. Per Sq. In.		Shearing Stress in Web, $b' \times d$ .	
					t	b	b'	d		C	S	Lbs. Per Sq. In.	Kind of Failure
<i>I</i> <sub>1</sub>	1-2-4	60	1.05	10- $\frac{1}{2}$ " stirrups	34	16	8	10	46,700	—	64,300	293	Tension
<i>I</i> <sub>4</sub>	"	60	1.10	Spaced 6"	34	16	8	10	32,410	—	41,500	203	"
<i>I</i> <sub>7</sub>	"	60	1.10	apart at	34	16	8	10	30,100	—	38,100	188	"
<i>I</i> <sub>3</sub>	"	60	0.93	either end.	34	24	8	10	55,700	—	57,500	347	"
<i>I</i> <sub>6</sub>	"	60	0.92	In Nos. 6, 8,	34	24	8	10	39,300	—	40,700	246	"
<i>I</i> <sub>8</sub>	"	60	0.92	5, 2- $\frac{3}{4}$ " rods	34	24	8	10	40,100	—	41,200	250	"
<i>I</i> <sub>2</sub>	"	60	1.05	were bent up	34	32	8	10	80,500	—	55,700	503	"
<i>I</i> <sub>5</sub>	"	60	1.05	In No. 9, 3- $\frac{1}{2}$ "	34	32	8	10	83,300	—	57,400	521	"
<i>I</i> <sub>9</sub>	"	60	0.97	plain rods	34	32	8	10	50,900	—	37,600	318	"
				were bent up.									
<i>M</i> <sub>1</sub>	"	30	0.74	None	3	24	8	9 $\frac{1}{2}$	22,000	1510	34,500	—	Tension
<i>M</i> <sub>2</sub>	"	30	0.75	"	3	24	8	9 $\frac{1}{2}$	22,000	1495	33,300	—	"
<i>M</i> <sub>3</sub>	"	30	0.83	"	3	24	8	9 $\frac{1}{2}$	22,000	1410	38,100	—	"
<i>M</i> <sub>4</sub>	"	30	0.91	"	3	24	8	9 $\frac{1}{2}$	24,000	1570	21,600	—	Compression
<i>M</i> <sub>5</sub>	"	30	1.04	"	3	24	8	9 $\frac{1}{2}$	28,000	1780	29,600	—	"
<i>W</i> <sub>1</sub>	1-2-4	30	0.94	Rods bent up	2	9	3	4 $\frac{1}{2}$	4,000	—	—	107	Bond
<i>W</i> <sub>2</sub>	"	30	0.94	"	2	9	3	4 $\frac{1}{2}$	5,100	—	—	136	"
<i>W</i> <sub>3</sub>	"	30	0.52	"	2	9	3	4 $\frac{1}{2}$	4,750	—	—	127	"
<i>W</i> <sub>4</sub>	"	30	0.52	"	2	9	3	4 $\frac{1}{2}$	4,000	—	—	107	"
<i>W</i> <sub>5</sub>	"	30	0.52	Rods and $\frac{1}{2}$ "	2	9	3	4 $\frac{1}{2}$	9,380	—	—	238	Tension and
<i>W</i> <sub>6</sub>	"	30	0.52	stirrups spaced	2	9	3	4 $\frac{1}{2}$	9,400	—	—	246	shear.
				3 $\frac{1}{2}$ " apart.									Compression
<i>W</i> <sub>7</sub>	"	30	1.05	In Nos. 5, 6,	2	9	3	4 $\frac{1}{2}$	12,850	—	—	330	and shear.
<i>W</i> <sub>8</sub>	"	30	1.05	7, and 8 the	2	9	3	4 $\frac{1}{2}$	13,550	—	—	349	Compression
<i>W</i> <sub>9</sub>	"	30	0.39	stirrups were	2	12	3	4 $\frac{1}{2}$	8,400	—	—	216	Shear
<i>W</i> <sub>10</sub>	"	30	0.39	$\frac{1}{8}$ "	2	12	3	4 $\frac{1}{2}$	8,000	—	—	205	"
<i>W</i> <sub>11</sub>	"	30	0.78	"	2	12	3	4 $\frac{1}{2}$	11,400	—	—	304	"
<i>W</i> <sub>12</sub>	"	30	0.78	"	2	12	3	4 $\frac{1}{2}$	12,700	—	—	346	"
<i>W</i> <sub>13</sub>	"	30	0.52	Expanded	2	9	3	4 $\frac{1}{2}$	7,800	—	—	217	"
<i>W</i> <sub>14</sub>	"	30	0.52	Metal	2	9	3	4 $\frac{1}{2}$	7,000	—	—	190	"
<i>W</i> <sub>15</sub>	"	30	1.05	"	2	9	3	4 $\frac{1}{2}$	13,800	—	—	384	Tension and
													shear
<i>W</i> <sub>16</sub>	"	30	1.05	"	2	9	3	4 $\frac{1}{2}$	12,600	—	—	350	Compression

The tests numbered *I* are from Bulletin No. 12, University of Illinois Engineering Experiment Station, 1907. Those numbered *M* were made by Professor F. B. McKibben at the Massachusetts Institute of Technology. Those numbered *W* are from Bulletin No. 1, Vol. 4, University of Wisconsin, 1907.

The following are additional data concerning these tests. In the beams marked *I* the concrete had a compressive strength in cubes of 1820 lbs. per sq. in. In Nos. 1, 3, 2, and 5, the bars were

deformed and had a yield point of 53,800 lbs. per sq. in. The other steel was plain with yield point of 38,300 lbs. per sq. in. The stirrups were of the deformed steel. The span was 10 feet. The loads in all beams were at the third points. In the beams marked *M* the concrete, in cubes, had an average compressive strength of 1790 lbs. per sq. in. The span was 12 feet. In the beams marked *W* the span of the first four was 6 feet. In the others this was reduced to 5 feet, while the whole length of the beam was  $6\frac{2}{3}$  feet. The strength of compression cubes of this concrete was 1120 lbs. per sq. in. Two of the three rods were bent up in beams 1-6, 9, 10, 13, and 14, while four of the six were bent up in other cases. The percentage of steel is in every case based upon the area *bd*.

As is usual in such tests, there were many failures by tension in the steel.

**Influence of Web Compression.** In order to show the additional bending moment, due to the part of the web that lies above the neutral axis, an example will be chosen in which the assumed dimensions are not in accordance with usual practice. This difference between the true and the approximate bending moments is given by subtracting (30) from (29), or,

$$b'd^2 C \left( \frac{3r + 2n}{6(r+n)^2} n - x + x^2 \frac{r + 2n}{2n} - x^3 \frac{r + n}{3n} \right)$$

should be added to values of *M*, as taken from Plate III. It will be noted that the first fraction within the parentheses is given by the outer curve in Plate III, and that the remainder of the expression is shown by the curves for various values of *t*.

Hence, the correction to be applied for web compression is found by multiplying the ordinate intercepted between the outer curve, and that for the given value of *t*, in Plate III, by *b'd<sup>2</sup>C*.

For example, let *b* = 40 inches, *d* = 32 inches, *b'* = 18 inches, *p* = 0.005, *t* = 4 inches, *C* = 500, and *S<sub>i</sub>* = 16,000 lb. sq. in. Since *t* = *d* ÷ 8, the intercept is, on the ordinate for *p* = 0.005, 0.143 - 0.095 = .048. Then, .048 × 18 × 32 × 32 × 16,000 ÷ 32 = 442,000 lb. in. By (27), *M* = .095 × 32 × 32 × 40 × 16,000 ÷ 32 = 1,950,000 lb. in., and the whole moment is 1,950,000 + 442,000 = 2,392,000 lb. in., or the web adds 22 per cent. to the moment as usually computed.



To show the effect of the web compression in a T-beam of ordinary design, let  $b' = 12$  inches,  $c = 6$  inches, and the beam otherwise like the last. Then the correction for web compression is  $(.143 - .123) 12 \times 32^2 \times 500 = 123,000$  lb. in. in a total of 2,373,000 lb. in., or about 5.2 per cent. The error is seen to increase rapidly as the slab or flange becomes thinner and the per cent. of steel increases. Thus, if the depth be 32 inches and the percentage of steel be 0.5, the error, for  $t = 4$  inches, is 2.4 times as much as when  $t = 6$  inches, if the width of the web be unchanged.

**Depth of T-beams.** Let it be required to find depth of a T-beam to have a resisting moment of 1,500,000 lb. in. The flange is 40 inches wide and 5 inches deep. The width of the web is determined by the number and size of the reinforcing bars, and the necessary spaces between and outside them. According to the recommended practice (see page 150),  $b'$  must be  $1.5 + 2\frac{1}{2} n$  diameters of the bars, where  $n$  is the number of such bars. Since the curves for  $t$  in Plate III depend upon values of  $d$ , it is necessary to assume the depth and make the value of  $p$  to correspond. Let  $S_t$  and  $C$  be assumed not to exceed 16,000 and 600 lbs. sq. in. respectively, and let  $d$  be taken as 24 inches, for trial. Then, as  $r$  is  $16,000 \div 600$ ,  $p$  is .69 per cent. and  $t = .208 d$ , so  $M = .135 \times 40 \times 24 \times 24 \times 600 = 1,870,000$  lb. in. The width of the web is found when the number and size of the rods have been decided upon. Since  $p$  is 0.69 per cent.,  $A = 24 \times 40 \times .0069 = 6.6$  square inches, and 7 one-inch square bars will be sufficient. The width is  $b' = 1.5 + 2.5 \times 7 = 19$  inches, and the weight of the beam must be found and the dead load moment added to 1,500,000. If the result be less than the computed resisting moment the design is safe. If the length be 20 feet the total moment is found to be 1,875,000 lb. in. As  $b'$  is rather large, it will be better to assume a greater depth and make the computations again; or, a number of smaller bars to provide sufficient area may be inserted in two rows. If  $p$  be 0.6 per cent. and  $d$  be 26 inches, 8 one-inch diameter rods will be sufficient, and may be placed in two rows, the width of web will be 14.0 inches, and the resisting moment will be 1,900,000 lb. in., while the moment of loads is found to be 1,833,000 lb. in.



## PROBLEMS

16. A T-beam has dimensions as follows:  $b = 42$  inches;  $b' = 12$  inches;  $t = 6$  inches;  $d = 20$  inches. The reinforcement consists of six three-quarter-inch rods, the safe stresses for  $S_t$  and  $C$  are 16,000 and 500 lb. per sq. in. respectively, and  $n$  is 15. What is the safe resisting moment of the beam?

17. In the last problem, for what thickness of flange will the neutral axis fall a distance  $t$  from the top?

18. In Problem 16 what per cent. of the whole bending moment is due to the web of the beam?

19. In Plate III how are the vertical lines indicating percentages of steel located?

20. A beam 20 feet long is to carry a uniform load, besides its own weight, of 500 pounds per linear foot, and a concentrated load of 4000 pounds at the middle. The effective width of the flange is 48 inches and its depth is 5 inches. If the depth of beam below the flange, or slab, be limited to 15 inches, what amount of steel is required?

21. In the last problem what saving in per cent. of steel is possible if the effective depth be increased 25 per cent.?

22. If, in Problem 20, the depth be unlimited, compute its value so that  $S_t = 16,000$  and  $C = 400$  lb. per sq. in.

23. Deduce the value of  $k$  for a T-beam, in terms of  $n$ ,  $d$ , and  $r$ . Why is this value the same as in a beam of rectangular section?

**Analysis of Flexural Stresses under Ultimate Loads.** The foregoing flexural formulas have been based upon the assumption that the stresses and corresponding deformations are in a constant ratio. While this theory is practically true for working loads, it is not even approximately so for loads that are nearly the ultimate for the beam. When stresses and deformations are plotted as abscissas and ordinates, it is noted that the diagram, called the

"stress = strain diagram," is a curve that follows very closely a parabola, having its origin at the point indicating the maximum stress and elongation, and its axis horizontal. Fig. 22 shows two conceptions of the parabolic stress diagram. In (a) the axis is on the upper line, and  $C$  is the assumed or

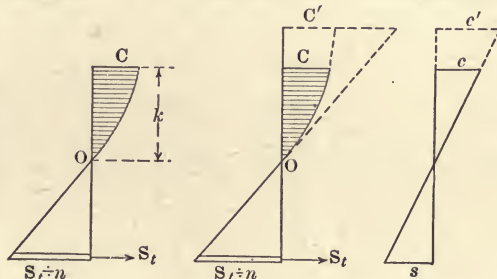

FIG. 22.

observed stress in the concrete. In (b) the axis is on  $C'$ , which is the ultimate stress, and  $C$  is any other stress that may be considered. In (b) the value of  $C'$  may be computed from any observed stress,  $C$  and corresponding deformation  $c$ .

These analyses do not hold if the steel be stressed beyond its elastic limit. In other words, the beam when loaded to destruction, should not break through failure of the steel.

**Stresses under Ultimate Loads.** In Fig. 23 the shaded part is a full parabola having the axis in  $C$ . The equation of this curve is  $y^2 = mx$ , and it may be shown that  $ab = bg$  when  $go$  is a tangent to the parabola at  $o$ . The area of  $abo$  is  $\frac{2}{3} ab \cdot ao$ , and the center of gravity of  $abo$  is  $\frac{5}{8} ao = \frac{5}{8} k$  above  $o$ . Since the tangent of the angle between the vertical and the line tangent to the curve at  $o$  is, at  $o$ , the ratio of the unit stress to the unit deformation,

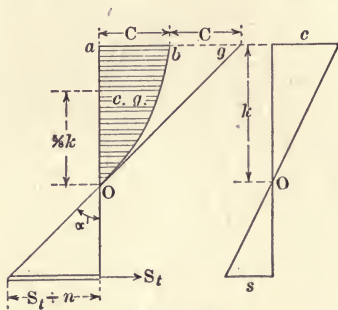

FIG. 23.

$$\tan aog = \tan \alpha = E_c$$

in which  $E_c$  is the initial coefficient of elasticity of the concrete. (See page 21.)

For equilibrium the sum of the horizontal forces is zero, so

$$\frac{2}{3} bCk = AS_t = pbdS_t \quad (32)$$

The resisting moment equals the bending moment and

$$\frac{2}{3} bCk \cdot \frac{5}{8} k + \frac{2}{3} bCk (d - k) = M$$

$$\text{or} \quad \frac{2}{3} bCkd - \frac{1}{4} bCk^2 = M \quad (33)$$

As sections remain plane during bending

$$\frac{S_t}{n} : (d - k) = 2C : k$$

$$k = \frac{2Cdn}{S_t + 2Cn}$$

$$= \frac{2dn}{r + 2n} \quad (34)$$

$$\text{Also from (32) and (34)} \quad k = d\sqrt{3pn + (\frac{3}{2}pn)^2} - \frac{3}{2}pnd \quad (35)$$

$$= \frac{3}{2} pdr \quad (36)$$

$$\text{From (34) and (36)} \quad p = \frac{4n}{3(r+2n)r} \quad (37)$$

$$\text{Putting (34) in (33),} \quad M = bd^2C \frac{4r+5n}{3(r+2n)^2} n \quad (38)$$

$$= N_4 C b d^2 \quad (39)$$

This may be used to find  $S_t$  by substituting  $S_t \div r$  for  $C$ .

Values of  $N_4$  are plotted in Plate IV as ordinates for  $n = 10, 15, \text{ and } 20$ , and percentages of reinforcement are fixed in accordance with (37). The use of this plate is similar to that of Plate I, and the same limitations exist as to what may be assumed.

For example, what is the ultimate resisting moment of a concrete beam in which  $b = 10$  inches,  $d = 18$  inches,  $S_t =$  elastic limit of the steel = 50,000 lb. per sq. in.,  $C =$  ultimate strength of concrete = 2000 lb. sq. in., and the reinforcement consists of four  $\frac{3}{4}$ -inch diameter steel rods? The percentage of steel is  $6 \times \frac{9}{16} \times .7854 \div 10 \times 18 = 1.46$ . (See page 156 for data concerning steel rods and bars.) From the diagram  $r$  is 25, and  $N_4$  is .29, so  $M = .29 \times 10 \times 18 \times 18 \times 2000 = 1,870,000$  lb. in. If the percentage of steel were less than that given, as, say, 1.2,  $r$  would be 28.4 and  $C$  would equal  $50,000 \div 28.4 = 1760$  lb. sq. in., and the beam would fail in the steel. In such cases the formulas and Plate IV do not apply as they are made with the assumption that the steel is not stressed beyond its elastic limit. For the solution of such cases see page 62.

As an example of design let it be required to find the dimensions of a beam 20 feet long to carry a uniform load of 600 pounds per linear foot, with a factor of safety of 4, or an ultimate load of 2400 pounds per foot of length. Let the elastic limit of steel be 50,000, and the ultimate compressive strength of concrete 1800 lb. sq. in. If these stresses be reached at the same time,  $r$  is 27.8, and  $p$  must be .0125.  $N_4$  is .278. Then omitting, for the time, the weight of the beam,  $M = \frac{1}{8} \times 2400 \times 20 \times 20 \times 12 = 1,440,000$  lb. in.  $= .278 \times 1800 \times bd^2$ . From this  $bd^2 = 2880$ . The breadth may be assumed, as a trial, at 10 inches, then  $d$  becomes 17 inches. There must be 2 inches of concrete below the steel, so the cross-section of the beam will be  $10 \times 19 = 190$  sq. in., and this amount, at 150 pounds per

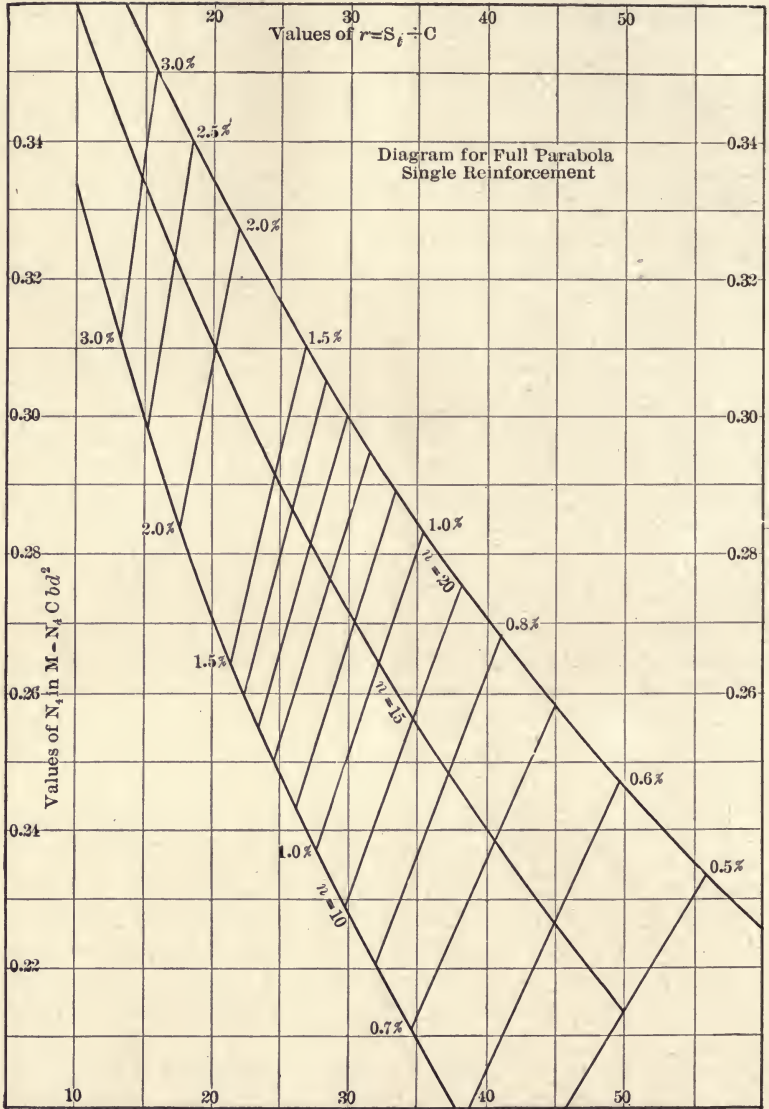

PLATE IV.



cubic foot, adds about 33 per cent. to the bending moment, so  $bd^2$  should be  $2880 \times 1.33 = 3830$ , and  $b$  and  $d$  may be 12 and 18 inches respectively. The reinforcing area is  $12 \times 18 \times .0125 = 2.7$  sq. in., and  $6 - \frac{3}{4}$  inches rods will be sufficient.

By comparing Plate I with Plate IV it is noted that the straight line relation calls for only about half as large percentage of steel to correspond with any given  $r$  as does the parabolic relation. On the other hand, with the same amount of steel, a greater moment is indicated in Plate IV, and the straight line formulas are the more conservative.

**PROBLEMS**

24. Design a beam of 18 feet span to safely carry a uniform load of 4 times its own weight, using 1 : 2 : 4 concrete and mild steel.

25. A beam 24 feet long, 10 inches wide, and 16 inches effective depth is reinforced with  $6 - \frac{3}{4}$  inch square bars. It breaks by compression under a uniform load, including its own weight, of 1650 pounds per linear foot. What is the probable stress in the concrete if the steel be capable of an elastic limit of 42,000 lbs. per in.?

26. Solve the last problem, using both  $n = 10$  and  $n = 20$ . Explain the meaning of the difference in results.

27. Use a factor of safety of 4, and solve Problem 24 by the straight line relations and Plate I.

**The General Parabolic Stress-Strain Relation.** This analysis is useful in interpreting the results of tests on beams in which

the stresses range from zero to any value up to the ultimate. The formulas were developed by Professor A. N. Talbot, and published in 1905 in Bulletin No. 4 of the University of Illinois Engineering Experiment Station.

Fig. 24 shows the stress-strain diagram in which  $C'$  is the ultimate unit stress and  $c'$

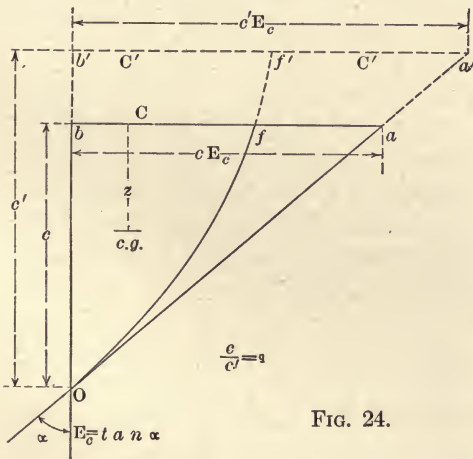

FIG. 24.

is the ultimate deformation of the concrete. Any other stress

and corresponding deformation are shown as  $C$  and  $c'$ . The tangent to the parabola at  $o$  indicates the initial coefficient of elasticity of the concrete, and  $\tan aob = \tan \alpha = 2 C' \div c' = E_c$ . The origin of the parabola is at  $f'$  and  $f'b'$  is the axis. In the equation for the parabola,  $x = \frac{1}{2} c' E_c$ , when  $y^2 = c'^2$ , so it may be written

$$y^2 = \frac{2 c' x}{E_c}$$

From Fig. 24  $(c' - c)^2 = \frac{2 c'}{E_c q} \left( \frac{E_c}{2 q} - C \right)$  if  $q = \frac{c}{c'}$

$$\text{and } \frac{C}{E_c c} = 1 - q/2 \quad (40)$$

$$\text{also } \frac{C}{C'} = \frac{E_c c (1 - q/2)}{\frac{1}{2} E_c c'} = 2 q (1 - q/2) \quad (41)$$

$$\begin{aligned} \text{The area } obf &= C'c - \frac{1}{3} c' C' + \frac{1}{3} (c' - c) (C' - C) \\ &= \frac{2}{3} C'c - \frac{1}{3} Cc' + \frac{1}{3} Cc \end{aligned} \quad (42)$$

$$\text{The area } oab = oa'b' \frac{c^2}{c'^2} = C'c'q^2 \quad (43)$$

$$\therefore \frac{\text{Area of parabola}}{\text{Area of triangle}} = \frac{\frac{2}{3}q - C/C' (\frac{1}{3} - \frac{1}{3}q)}{q^2} \quad (44)$$

$$= 1 - \frac{1}{3} q \quad (45)$$

This expression shows the relation between the sums of the compressive stresses in the beam according to the parabolic, and the straight line theories when  $k$  is substituted for  $c$ .

In equation (40)  $C$  is the stress in the outer fiber according to the parabolic, and  $E_c c$  is the stress at that place according to the straight line assumption, or  $ab$  in Fig. 24.

The center of gravity of  $ob'f'$  is  $\frac{3}{8} ob'$  below  $b'$ . As the area of  $ob'f'$  is  $\frac{2}{3} ob' \times b'f'$ , and the area of  $obf$  has been found (42), the distance of the center of gravity of  $obf$  below  $b$  can be found in the ordinary way. Letting  $c$  equal  $k$

$$\frac{z'}{k} = \frac{4 - q}{12 - 4q} \quad (46)$$

For equilibrium, the horizontal forces are zero, so

$$b \left( \frac{2}{3} C'k - \frac{1}{3} C \frac{k}{q} + \frac{1}{3} Ck \right) = AS_t = pbdS_t \quad (47)$$

$$b \left( \frac{2}{3} k \frac{C}{2q(1-q/2)} - C \left( \frac{1}{3} \frac{k}{q} - \frac{1}{3} k \right) \right) = AS_t - pbdS_t$$

$$\text{from which} \quad bCk \frac{3-q}{3(2-q)} = AS_t = pbdS_t \quad (48)$$

As the bending moment equals the resisting moment,

$$M = bCk \frac{3-q}{3(2-q)} (k-z) + AS_t (d-k) \quad (49)$$

$$= bCk \frac{4(3d-k) - q(4d-k)}{12(2-q)} \quad (50)$$

Since a vertical section remains plane during bending, from (37) and from Fig. 24.

$$\frac{S_t}{n} : \frac{2c}{2-q} = (d-k) : k$$

$$\text{and} \quad k = \frac{2dn}{r(2-q) + 2n} \quad (51)$$

$$\text{From (48) and (45)} \quad pr = \frac{3-q}{3(2-q)} \cdot \frac{2n}{r(2-q) + 2n} \quad (52)$$

$$p = \frac{(3-q)k^2}{6(d-k)nd} \quad (53)$$

Substituting (48) in (47)

$$M = bd^2 C \frac{2(3-q)(r(2-q) + 2n) - (4-q)n}{3(2-q)(r(2-q) + 2n)^2} n \quad (54)$$

$$= N_5 bd^2 C \quad (55)$$

If  $q$  be zero, the above formulas become the same as in the straight line theory, and if  $q$  be made equal to unity, these formulas reduce to the corresponding ones under the full parabolic assumption, as of course they should.

In order to plot  $N_5$ , the fraction in (53) may have  $q$  successively  $\frac{1}{4}$ ,  $\frac{1}{2}$ ,  $\frac{2}{3}$ , or any other assumed value, and a curve is made for each of these assumptions. For use with safe working loads and stresses  $q$  may be taken as  $\frac{1}{4}$ . The larger values of  $q$  are useful in investigating stresses near the ultimate.

In Plate V the  $q$  curves are plotted, with values of  $N_5$  as ordinates and values of  $r$  as abscissas, from equation (54); while the curves for percentage of steel are taken from equation (53). To illustrate the use of this diagram, let it be required to find



the stresses in the steel and concrete in a beam having the following dimensions. Breadth, 8 inches; depth, 11 inches, total, and 10 inches effective; span 12 feet, and 2.76 per cent. of steel reinforcement. A total load of 15,000 pounds was applied at the one-third points, causing rupture by compression of the concrete. The bending moment is  $7500 \times 4 \times 12 = 360,000$  lb. in. In the diagram, with  $q = 1$  and  $p = 2.76$  per cent.,  $N_5$  is found to be 0.33 and  $r$  is 15.6. Then  $0.33 C \times 8 \times 10 \times 10 = 360,000$  and  $C = 1363$  and  $S_t = 21,300$  lb. sq. in. This beam was nominally a 1:3:6 mixture, and must have been only fairly well made to give this result for ultimate compression. The working load for this beam is found by taking  $q = \frac{1}{4}$  in the diagram. Then  $.248 \times 600 \times 8 \times 10 \times 10 = M = 119,000$  lb. in., and the load is 4960 pounds, giving a factor of safety of about 3. Using the straight line formulas and Plate I,  $N_1$  is 0.236, so  $M$  is 113,300 lb. in., and the computed load 4720 pounds.

Let it be required to design a beam to carry a load which makes the bending moment 500,000 lb. in. If the working stresses be desired,  $q$  is taken as  $\frac{1}{4}$ ,  $C = 500$ , and  $S_t = 16,000$  lb. per sq. in. From the diagram  $N_5$  is 0.161 and  $p$  is about 0.6 per cent., so  $0.161 \times 500 bd^2 = 500,000$  and  $bd^2 = 6210$ . If  $b = 12$  inches the effective depth will be 23 inches, and the reinforcement may be 5 round rods,  $\frac{5}{8}$  inch diameter, or 4 round rods,  $\frac{3}{4}$  inch diameter. (See page 156.) It will be noted that the assumption of  $q = \frac{1}{4}$  gives a factor of safety of  $16 \div 7 = 2.3$ .

In the following example the reinforcement is not sufficient to develop the full strength of the concrete and failure would take place first in the steel. Let  $S'_t = 50,000$  and  $C' = 2000$  lbs. per sq. in.,  $b = 10$  inches, effective depth = 18 inches and  $p = 0.012$ . It is required to find the ultimate bending moment for the beam. With  $r = 25$  and  $p = 1.2$  per cent. in Plate V,  $q$  is seen to be a little more than  $\frac{3}{4}$ , in which case  $C = 0.94 \times 2000 = 1880$  lb. per sq. in. (see small diagram *a* on Plate V). With this value of  $C$  and  $r = 25$ , the strength of the steel would not be the ultimate, and the proper value of  $q$  is sought by trial. If  $r$  be assumed at 26,  $C$  is about 19,500 and  $S'_t$  is too large. If  $r$  be taken as 25.6,  $q$  is .85,  $N_5$  is .252,  $C$  is  $2000 \times .97$ , and  $S'_t$  is 49,700 lb. per sq. in. Then  $M = .252 \times 1940 \times 10 \times 18 \times 18 = 1,585,000$  lb. in.



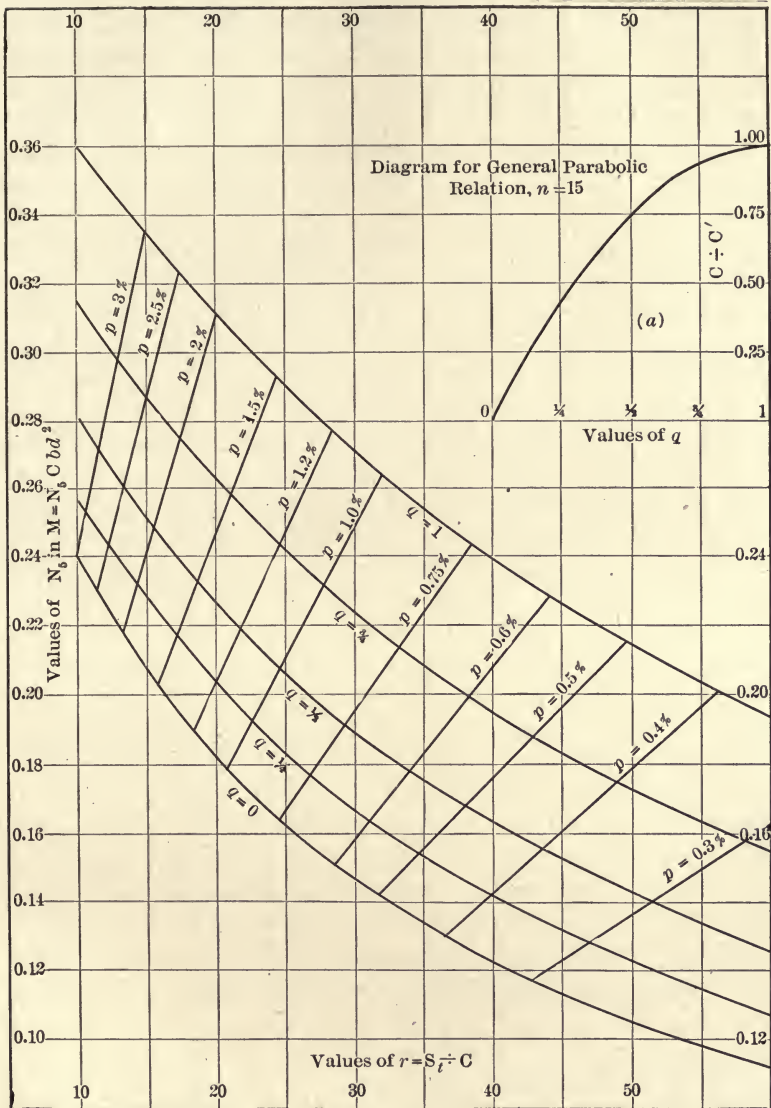

PLATE V.

Let a beam be subjected to a bending moment of 350,000 lb. in. If  $b = 10$  inches, effective depth = 17 inches, and  $p = 1$  per cent., what will be the stresses in the steel and in the concrete? Here  $q$  and the value of  $C$  are dependent upon each other and are both unknown. It may be assumed that the stress will be a fourth of the ultimate, in which case (a) of Plate V gives  $q$  as about .15. Then  $N_s$  is .186 and  $r$  is 22, for  $p = 1$  per cent. So  $0.186 C \times 10 \times 17 \times 17 = 350,000$  and  $C = 650$ .  $S_t = 650 \times 22 = 14,300$  lb. per sq. in. If the concrete be such that the ultimate strength is very different from  $650 \times 4$  another assumption must be made and the computations repeated.

If the straight line relation be used,  $q$  is zero,  $N_s$  is 0.179 and  $C$  and  $S_t$  become 675 and 14,400 lb. per sq. in. respectively. For working loads and stresses this method of computation is safe without being wasteful of material.

When a beam is tested with known loads, it is usual to determine the value of  $k$  by extensometers and direct measurements. If  $k$  be substituted in (43)  $z$  becomes known in terms of the still unknown  $q$ . The value of  $z$  varies within rather narrow limits:

$$q = 0, z = \frac{1}{3} k; \quad q = \frac{1}{4}, z = \frac{1}{4} k; \quad q = \frac{1}{2}, z = \frac{7}{10} k; \quad q = \frac{3}{4},$$

$$z = \frac{3}{8} k; \quad q = 1, z = \frac{3}{8} k.$$

So if  $k$  be known,  $z$  is found without great error even if  $q$  be only approximately assumed. The manner in which the beam fails is a fair indication of  $q$ . If the failure be by crushing of the outer fibers of the concrete,  $q$  is unity; if the steel break,  $q$  is probably about  $\frac{1}{4}$ , and failure by diagonal tension usually indicates a stress in the steel due to  $q = \frac{1}{4}$  to  $\frac{1}{2}$ . By means of the extensometers on the beam and on direct compression pieces of the same kind of concrete,  $q$  is determined with greater accuracy.

When  $z$  is known the resisting moment of the beam is often most conveniently stated in terms of the steel, or

$$pbd S_t (d - z) = M$$

where  $M$  is the moment of the loads.

The diagram in Plate VII shows values of  $q$  in terms of  $k$  and  $p$  for  $n = 15$ . It is readily seen that, for a given percentage of steel,  $k$  must be found between the upper and lower curves intercepted by that ordinate. The measured value of  $k$  often

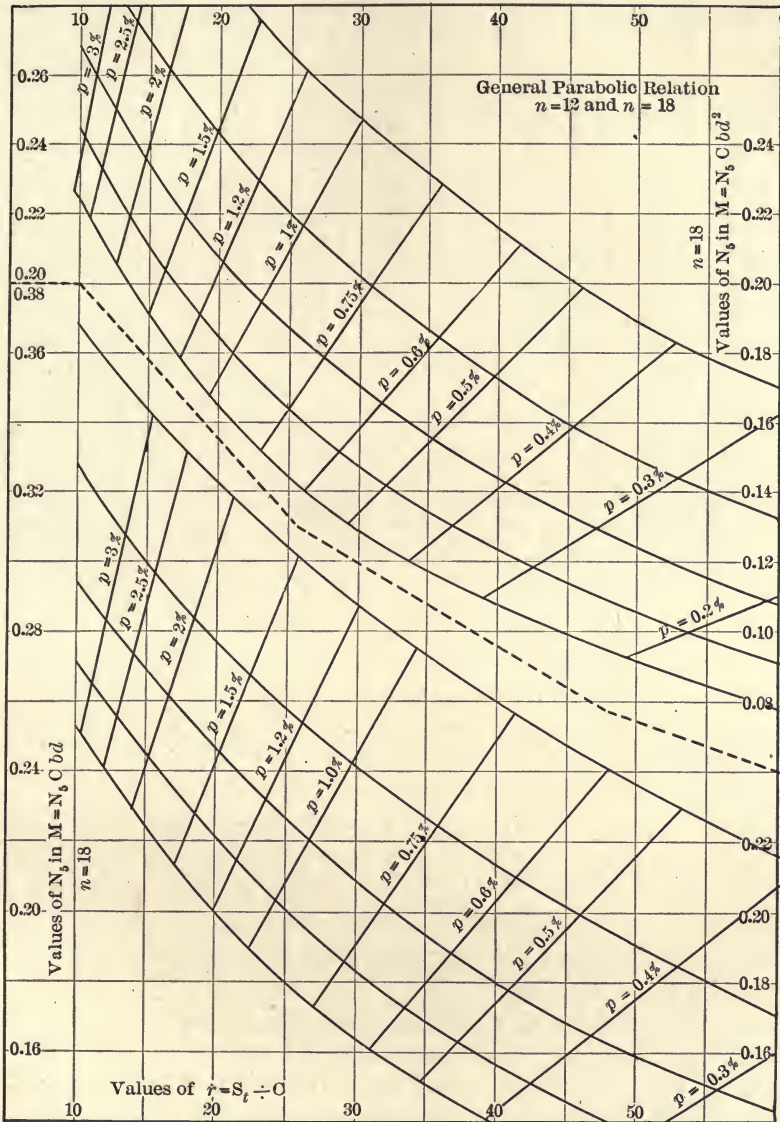

PLATE VI.

falls outside these limits, indicating that  $n$  is other than 15, upon which assumption Plate VII is made. In the following table  $k$  is taken from measurement,  $b = 8$  inches, and the effective

Per Cent of Steel	$k$	Moment of Loads Lb.-In.	$q$	Pounds per Sq. In.		Manner of Failure
				$C$	$S_c$	
.74	.380 $d$	192,000	$\frac{1}{4}$	1362	36,800	Tension in steel.
.74	.410 $d$	168,000	$\frac{1}{4}$	1100	33,000	" " "
1.23	.470 $d$	288,000	$\frac{1}{4}$	1762	35,100	" " "
1.60	.501 $d$	312,000	$\frac{1}{4}$	1775	29,300	Diagonal tension.
1.66	.505 $d$	336,000	$\frac{1}{2}$	1900	30,400	" "
1.84	.552 $d$	336,000	$\frac{1}{2}$	1720	28,400	" "
2.21	.605 $d$	360,000	$\frac{3}{4}$	1065	26,100	Compression following diagonal tension.

depth is 10 inches. The method of computing  $C$  and  $S_t$  is shown by taking the sixth beam as an example. In Plate VII for  $k$  and  $p$  as given,  $q$  is found to be slightly more than  $\frac{1}{2}$ . Then in Plate V, with  $q = \frac{1}{2}$  and  $p = 0.0184$ ,  $N$  is 0.244 and  $r$  is 16.5, then

$$0.244 C \times 8 \times 10 \times 10 = 336,000$$

$$C = 1720$$

$$S_t = 170 \times 16.5 = 28,400$$

The stress in the steel may be found otherwise, as indicated above, by first finding  $z$  from  $k$  when  $q = \frac{1}{2}$ .

$$d - z = 10 - \frac{7}{20} \times 5.52 = 8.06 \text{ inches}$$

$$.0184 \times S_t \times 10 \times 8 \times 8.06 = 336,000$$

$$S_t = 28,325 \text{ lb. per sq. in.}$$

which result agrees substantially with that obtained from the Plate V.

To illustrate the effect of the assumption as to  $q$ , let the first beam in the above table be investigated for  $q = 0$ ,  $q = \frac{1}{4}$ ,  $q = \frac{1}{2}$ ,  $q = \frac{3}{4}$ , and  $q = 1$ . The corresponding values of  $S_t$  are readily found to be: 36,500; 36,800; 37,200; 37,400, and 38,200 pounds per square inch, and the difference between the highest and the lowest is but about 6 per cent. of the former. If  $q = 0$ , and  $q = 1$  be omitted, the results agree within 1 per cent. whether



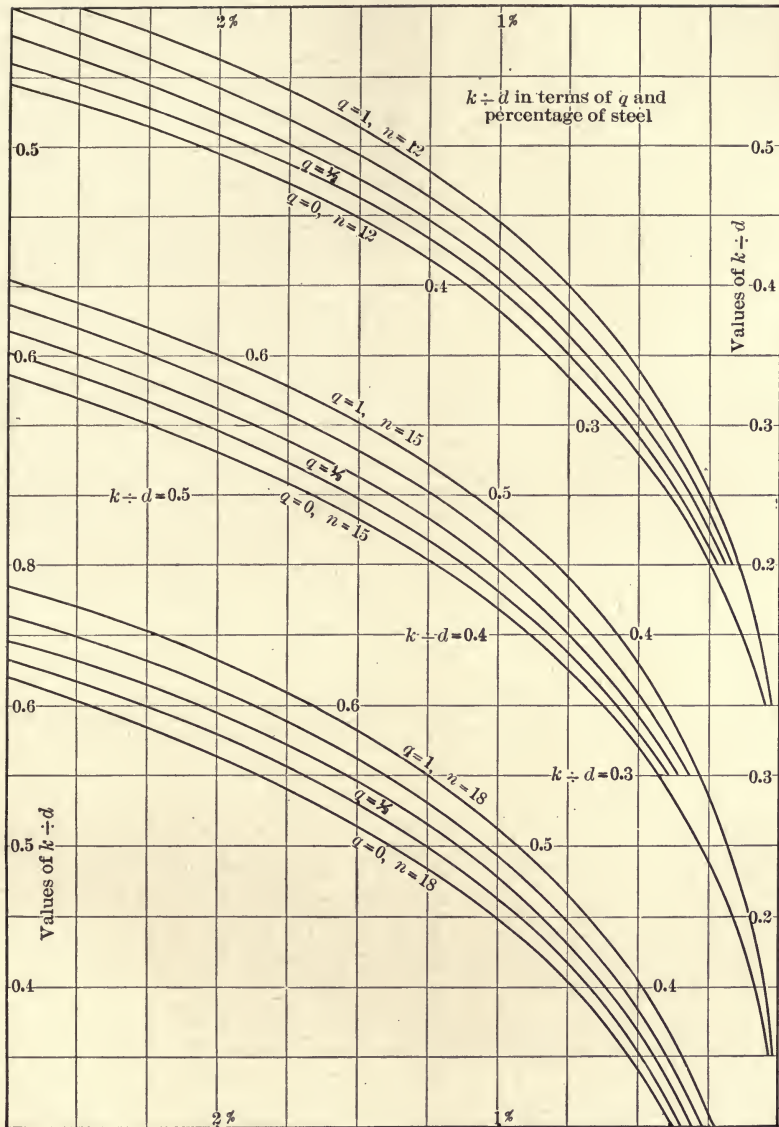

PLATE VII.

$q$  be assumed as  $\frac{1}{4}$ ,  $\frac{1}{2}$ , or  $\frac{3}{4}$ . The computed stresses in the concrete, however, vary materially according to the assumption as to  $q$ .

Plate VI contains diagrams for computing  $N_s$  in (55) when  $n$  is either 12 or 18. The next to the last of the above beams gives values of  $C$ : 1820, 1720, and 1630, and for  $S_t$ : 28,200, 28,400, and 28,600 lbs. per sq. in. for  $n = 12, 15,$  and  $18$  respectively. The diagram (a) of Plate V applies also to this one.

For working stresses  $q$  is taken as  $\frac{1}{4}$  and  $n = 15$ . In experimental beam tests these factors should be previously known.

### PROBLEMS

28. A reinforced concrete beam has  $b = 10$  inches, effective  $d = 14$  inches, and four steel rods  $\frac{3}{4}$ -in. diameter in the tension side, two inches from the bottom. If the ultimate compressive strength of the concrete be 2000, and the elastic limit of the steel be 40,000 lbs. per sq. in., find the ultimate resisting moment of the beam.

29. If, in the last problem, the safe working stresses in the concrete and steel be limited to 600 and 16,000 lb. per sq. in., compute the safe resisting moment of the beam.

30. A beam 12 feet long of 1:2:4 concrete is to be designed to safely withstand a bending moment of 150,000 lb. in. Consult Chapter III. Make assumptions as to  $C$  and  $S_t$ , and compute  $b$ ,  $d$ , and  $p$ .

31. Solve the last three problems by means of the "straight line" methods where such solution is practicable.

32. Solve the above problems if practicable by the "full parabolic" relation, and tabulate the results of the three methods of solution.

33. In Plate V plot other curves for  $p$  for five values of  $q$ .

**Diagonal Tension in Beams.** When a horizontal beam is subjected to vertical loads, there is a tendency in each small

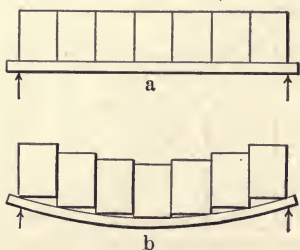

FIG. 25.

particle to move, both vertically and horizontally, with respect to the particle adjacent above, below, and at the ends. Beams have been built, for experimental purposes, of brick resting on a strap of iron, as shown in (a), Fig. 25. Under a load the tendency is to assume a position like (b), that is, for bricks to move vertically with respect to the ones adjacent. This represents the common conception of vertical shear.

When a pile of boards or a pack of cards is bent, as shown in Fig. 26, each board or card slips upon the one above or below it. This action is also that of shear, and is noticeable in beams of laminated material. Deep floor beams of hard pine frequently fail by splitting from end to end in a horizontal plane, midway between the top and bottom. The effect of the splitting is to increase the deflection beyond safe limits, although the tension or compression of the outer fibers may not be excessive. In general, the upper and lower fibers of beams are

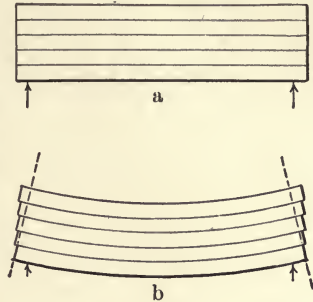

FIG. 26.

subjected to greater stresses than occur in the interior of the same, and only when the material is such that it fails under comparatively light stresses, in directions other than horizontal, is the shear of relatively great importance.

This condition exists in reinforced concrete beams where failure by diagonal tension occurs at some distance from the outer fibers, while the latter are sustaining materially larger stresses. The reason clearly is that the concrete is stronger in compression than in tension, and that the strength of the lower or tension edge is supplemented by the steel.

**Distribution of Stresses in a Homogeneous Beam.** That there are horizontal and vertical forces acting as couples on the sides of all small cubical particles in a beam, is a well known principle of mechanics. This principle is illustrated in Fig. 26, and Fig. 27 shows that, for equilibrium, the horizontal and vertical unit shears must be equal to each other. The vertical shear is readily computed from the loads on the beam, and the average unit shear is this value divided by the area of the cross-section. This average unit shear is, however, not the maximum; or, in other words, the unit shear varies from the outer fiber to the neutral axis.

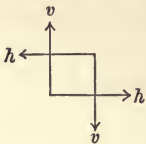

FIG. 27.

Let the beam in Fig. 28 be cut by two vertical sections distant  $dx$  apart, and let the sum of the stresses above any horizontal plane, as  $mn$ , be  $H$  and  $H'$ . In general  $H$  and  $H'$  will be unequal, and  $np$  will have a tendency to move toward  $om$ , causing



shearing along  $mn$ . Let  $z$  be the distance from the neutral axis to any fiber, as  $mn$  of cross area  $da$ , and  $b$  be the breadth of the beam at this point. Then, from the ordinary flexural formula, the unit stress at  $o$  is  $S = Mc/I$ , and at  $p$  is  $S = M'c/I$ , where  $c$  is the distance from the neutral axis to the extreme fiber, and the stresses on a fiber of  $da$  section, distant  $z$  from the neutral axis, will be  $M/I \cdot da \cdot z$  and  $M'/I \cdot da \cdot z$ . The summation of these stresses for values of  $da$  between  $z$  and  $c$

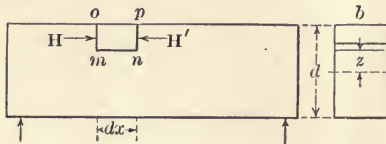

FIG. 28.

will give  $H$  and  $H'$  respectively. The difference,  $H' - H$ , is the shear on the surface  $mn \cdot b$  or  $b dx$ , and  $M' - M = dM$ . If  $v$  be the unit shearing stress on  $mn \cdot b$  and  $V$  the total vertical shear at the section,

$V = dM \div dx = (M' - M) dx$ , as found above, and  $v = (H' - H) \div b dx$ . Using these values, the expression for  $v$  becomes

$$v = \frac{V}{Ib} \int_z^c da z \tag{56}$$

or

$$v = \frac{Vm}{Ib} \tag{57}$$

where  $m$  is the statical moment with reference to the neutral axis, of the part of the cross-section between the outer fibers and those distance  $z$  from the neutral axis. Formula (56) applies to any form of cross-section in which  $b$  is the width at  $z$  from the neutral axis. In case the section is rectangular the value of the unit shear, at the neutral axis, becomes

$$v = \frac{3}{2} \frac{V}{bd}$$

or  $\frac{3}{2}$  of the average shear. It is seen that  $v$  is zero when  $V$  is zero, or at a dangerous section, that it increases as the section is nearer the end of the beam, and vertically, the maximum is at the neutral axis since  $m$  is there maximum.

If the unit stresses for a vertical rectangular section be plotted, the curve so formed will be a parabola, as shown in Fig. 29, where the maximum abscissa is on the neutral axis.

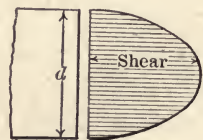

FIG. 29.



**Shear and Axial Stress.** If the horizontal and vertical shear,  $v$ , and the axial stress,  $C$  or  $S$ , be resolved into components parallel and perpendicular to the diagonal of the elementary prism, the latter component is the diagonal tension. When this is maximum the value is  $t = \frac{1}{2} S + \sqrt{v^2 + \frac{1}{4} S^2}$ , and it makes an angle,  $\theta$ , with the neutral axis, such that  $\cot 2\theta = S \div 2v$ . The directions of these maximum stresses are shown in Fig. 30. The curves give the directions of the stresses only and are not lines of equal stresses. If the beam were to fail by diagonal tension, fracture would take place in sections perpendicular to these curves, and hence reinforcing rods should follow approximately the lines in Fig. 30. Since the bending moment and the tensile stresses decrease from the middle toward the ends of a beam, it follows that fewer horizontal reinforcing rods are required near the extremities than where the moment is greater. The rods may be of different lengths, stopping short of the ends, and still give sufficient horizontal support, but it is,

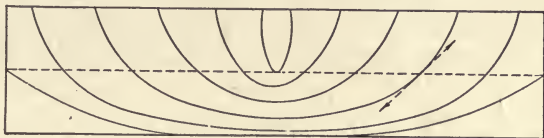

FIG. 30.

rather, the custom to bend them upward at proper intervals to reinforce for diagonal tension. In addition, vertical rods, somewhat shorter than the depth of the beam, are often inserted for the purpose. It is readily seen that this is not an ideal arrangement since they do not follow the direction of the stresses, but as it is easier to so place them than to fasten them with the proper slant a greater number may be used at the same expense.

An inspection of the formulas for  $t$  and  $\theta$  show that where  $S$  is zero,  $t = v$ , and the direction of the stress is  $45^\circ$  with the neutral axis. This is the condition at the end of the beam, or at a point of inflection, and along the neutral axis where  $v$  is the only stress. When  $v$  is zero  $\theta$  is zero and  $S$  is the only stress acting, as is the case along the upper and lower edges, and at any point of maximum moment.

If  $v$ ,  $S$ , and  $t$  be computed and plotted, as in Fig. 31, it will

be seen that the influence of shear is not very marked in beams of normal dimensions and loading, and may be neglected. This applies, however, only to beams of homogeneous material, and the effect of diagonal tension is of great importance in reinforced concrete construction. To illustrate the effect of shear upon

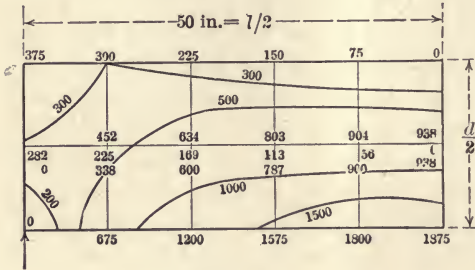

FIG. 31.

the stresses in various parts of the vertical longitudinal section, let a beam be assumed of breadth 1 inch, depth 20 inches, and length 100 inches, with a uniform load of 100 pounds per linear inch.

In Fig. 31 are shown values of  $v$ ,  $S_t$ , and  $t$ , in the lower half of the beam, at the lower fibers, at the neutral axis, and midway between, and on vertical sections 10 inches apart. At the bottom  $v$  is zero; at the neutral axis  $S_t$  is zero. On the mid-section between,  $t$  is given above the line, with  $v$  and  $S_t$  in order below. Some lines have been drawn joining points of equal stress, but it will be noted that the maximum stresses are in the lower fibers.

### PROBLEMS

34. At what places in a beam are the stresses zero?
35. If, in addition to the uniform load, the above beam be loaded with 1000 pounds at 20 inches from each end, what changes will result in Fig. 31? Compute and plot values of  $t$ .
36. What would be the nature of the stress (a) in a horizontal rod through the load in Fig. 25? (b) in a vertical rod in Fig. 26?

**Distribution of Stresses in Reinforced Beams.** While the above discussion and formulas refer to homogeneous beams, they may be applied to reinforced beams if, for the steel, there be substituted enough concrete to take its place in resisting deformation. As the deformation is proportional to  $E$ , it follows that  $n$  times the area of the steel displaced must be added. A conception of this substitution is shown in Fig. 43, where the holes left by the steel are filled by the concrete, and  $n - 1$  times as much is added at the same distance from the neutral axis,

as was the steel. Then the moment of inertia may be computed and used in (57) for any cross-section. When the stresses are increased so that the concrete in tension is broken, different conditions arise, which will be considered below.

In Fig. 27  $h$  is the difference,  $H' - H$  in Fig. 28, if the former figure be applied to the whole cross-section, and  $v$  be the vertical shear, then the arm of  $h$  is the distance from the center of gravity of the steel to the point of application of the compressive stresses in the concrete, or  $j$  in (12). Then  $Vdx = hj$ ,  $h$  being infinitesimal. Also, since  $H' - H$  is the total shear on a section above the steel, as  $mn$  in Fig. 28,  $h = v b dx$ . Making an equation of the two values of  $h/dx$ , there results, at the neutral axis

$$v = \frac{V}{bj} \tag{58}$$



FIG. 32.

In general,  $v$  is the vertical shear divided by the distance between the centers of compression and of tension, whatever the shape of the cross-section or distribution of reinforcement may be.

Since  $H' - H$  is uniform from the steel to the neutral axis when there is no tension in the concrete, the value of  $v$  remains unchanged below the neutral axis, and the diagram for  $v$  over the entire depth is like Fig. 33. The upper part of the figure is determined as though the beam were not reinforced. The value of  $j$  may be taken approximately as  $0.875 d$  for rectangular beams, and as  $d - \frac{1}{2} t$  in T-beams. In T-beams  $b$  is the breadth of the web.

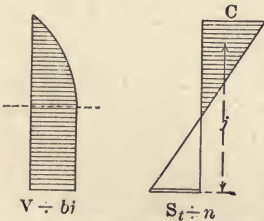

FIG. 33.

In computing the horizontal stresses in beams it is customary to neglect the tensile strength of the concrete, as this strength is destroyed, near the points of maximum moment, under comparatively light loads. This is proper practice, but an inspection of beam failure, such as shown in Fig. 34, makes it plain that the steel and concrete, acting together, fail as a beam along lines similar to those of maximum stress in homogeneous beams. It is the practice to counteract this tendency to weakness by



inserting reinforcement in suitable fashion to prevent the opening of such cracks. Typical beam cracks and two common styles of reinforcement to resist diagonal tension are shown in Fig. 35, (a) and (b). In (a) a rod that is unnecessary, to the left of  $b$  as horizontal reinforcement, is bent up at an angle of about  $45^\circ$  to cross the possible cracks as shown. The same result is attempted in (b) where rods, called stirrups, are placed vertically and looped around the horizontal rods. If the beam were of wood, a crack such as shown might be closed by nails

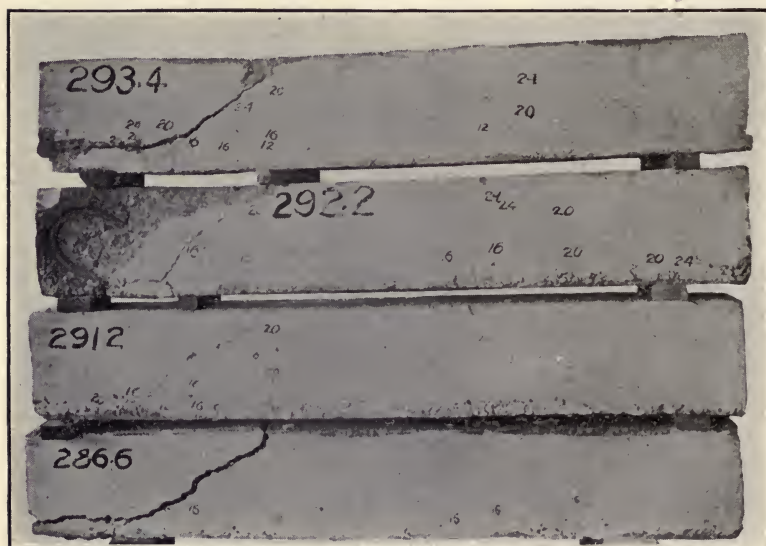

FIG. 34.

driven where the stirrups or the diagonal rods are indicated, both the nails and the reinforcement being stressed longitudinally rather than across their sections.

Usually with diagonal or vertical rods the assumption is that a rod as  $ff'$  takes a part, and that the concrete takes the remainder, of the average vertical shear over the space  $s$ , represented by the component of this shear in the direction of the rod. The usual assumption is that the steel and the concrete act together, rather than separately, in resisting shear. Practically, a definite part of the shear is assigned to a part of the shearing strength of the concrete and the rod is designed to



carry the remaining vertical shear normal to the surface  $bs$ , where  $b$  is the breadth of the beam. The tension in the rod is distributed by the remaining shearing strength of the concrete through the distance  $\frac{1}{2}s$  toward the adjacent rods. It is well proved by experiments on beams with web reinforcement that, for even greater than safe working stresses, the concrete is capable of taking a material part of the shearing and diagonal stresses; and that not more than two thirds of the vertical shear, due to loads, need be taken care of by the web reinforcement, the other third being well within the safe-working shearing strength of the concrete.

**Working Shearing Stresses.** The recommended limits of shearing stresses to be allowed are stated on page 150, and are based upon observations on beams composed of concrete capable of holding 2000 lb. per sq. in. in compression at the end of 28 days. The first rule (a) applies to rather thin slabs and to small beams of rectangular cross-section.<sup>1</sup> Such beams may

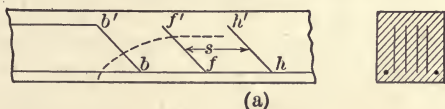

(a)

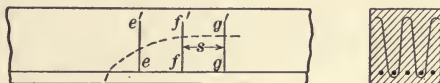

(b)

FIG. 35.

frequently be designed, with horizontal steel only, without exceeding the limit of 40 pounds per square inch. Large beams and girders are usually of the T-section, and the cross area is much reduced. As a result the limit named in (a) is nearly always exceeded and web reinforcement is introduced. Where the horizontal reinforcement is made up of a number of rods such that they may be bent up in pairs at frequent intervals, the web strength of the beam is obviously increased and the unit shearing strength of the cross-section of the beam is greater than before. When the number of such bars to be bent up is such that every probable crack will be crossed by at least one of them below the neutral axis, the maximum shearing stress on the area of the cross-section may be increased to 60 lb. per sq. in. according to rule (b). If the bent-up rods or vertical stirrups be spaced  $\frac{3}{4}$  of the depth apart, the maximum shearing stress may be taken as 120 lb. per sq. in.

<sup>1</sup>See page 79 for discussion of this question.

**Computation of Stresses in Web Reinforcement.** While, in general, such stresses are not capable of exact computation, approximate values may be found that are on the side of safety. In Fig. 36 (a), the average vertical shear, due to external loads on the beam over the space  $\frac{1}{2} s$  on each side of a vertical stirrup is carried in part by the concrete, and in part by the steel. If  $V'$  be the shear not apportioned to the concrete, the maximum unit shear will be  $v = V' \div bj$ , or about  $V' \div 0.875 bd$ . This

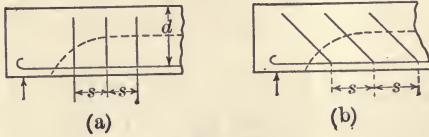

FIG. 36.

is the vertical component of the unit diagonal tension and causes tension in the vertical reinforcement. If the section area of all the stirrups, acting in a right section, be  $a$ , and the unit tensile stress be  $S_t$ , the whole load on the rods will be  $aS_t$ , and

$$aS_t = vbs = \frac{V's}{j} \quad (59)$$

For usual values of  $S_t$  and  $j$ , in rectangular beams, this becomes

$$a = \frac{V's}{14,000 d} \quad (60)$$

or

$$s = \frac{14,000 ad}{V'} \quad (61)$$

It is clear that vertical reinforcement is ineffective to prevent vertical cracks such as appear under very small loads, but that they become more efficient as the cracks incline more toward the middle. In case the beam is of the T-section, formula (59) is used.

When the rods are placed at an angle,  $\alpha$ , with the horizontal, the distance between the rods is, for the same horizontal spacing,  $s \sin \alpha$ , and the tension on each rod becomes

$$aS_t = \frac{V's}{j} \sin \alpha \quad (62)$$

The rods are usually bent up at an angle of  $45^\circ$ , especially where several pairs are inclined; then, for usual values of  $S$  and  $j$ , in rectangular beams,

$$a = \frac{V's}{19,800 d} \quad (63)$$

and 
$$s = \frac{19,800 ad}{V'} \quad (64)$$

To investigate a design the solution for  $S_t$  is made from (59).

The vertical shear in these formulas is usually considered as two-thirds that occasioned by the loads on the beam, the other third being taken by the concrete.

**Spacing Web Reinforcements.** The spacing of the stirrups or bent-up rods may be limited otherwise. As stated above, a diagonal tension crack should always be crossed by a piece of web reinforcement below the neutral axis. This obviously requires, with vertical stirrups and  $\alpha$  assumed as  $45^\circ$ , that the horizontal spacing shall be less than  $0.6d$  for rectangular cross-sections, and less than  $d - t$  for T-beams. As most of the heavy beams are of the latter form, it is common practice to make the maximum spacing not more than  $\frac{3}{4}d$ , as is recommended on page 151.

If values of  $s$  in (59) and (62) give spacing less than  $\frac{3}{4}d$ , the smaller distance must be used. This is not at all unusual in deep beams. For example,<sup>1</sup> slabs 30 inches deep carrying heavy railway traffic over 23-foot spans in Chicago, have the U-shaped stirrups 18 inches apart.

**Points for Bending-up Bars.** Since the bending moments in a beam decrease from the maximum near the middle to zero at, or near, the ends, it follows that the same amount of horizontal reinforcement is not required throughout the whole length of the beam.

If  $M$  be the maximum bending moment of a beam fixed at the ends,  $M_1$  be the moment at any other point as  $b$ ,  $w$  the uniform load between  $a$  and  $b$ , and  $wl/2$  the shear at the left support

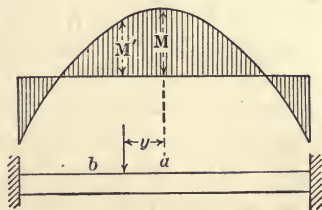

FIG. 37.

$$M_1 = M - \frac{1}{2} wx^2$$

from which the bending moment at any point may be computed.

In reinforced beams extending over several spans there is more or less continuity over and fixedness at the supports. As it is unknown at the time of making the design what the exact

<sup>1</sup> For details of tests of three of these beams see Bulletin No. 28, University of Illinois Engineering Experiment Station, 1908.



distribution of the loads will be, it is usual to assume the maximum positive bending moment to be  $\frac{1}{2} w l^2$  at the middle of all beams except the end spans where it is  $10 w l^2$ . The maximum negative bending moments are  $\frac{1}{2} w l^2$  at all supports except those at the ends where the moment is  $\frac{1}{5} w l^2$ . If the diagrams of bending moments be assumed to be parabolas with origins at the mid-sections of the beams, the height of the diagrams being the sums of the positive and negative moments, the curves

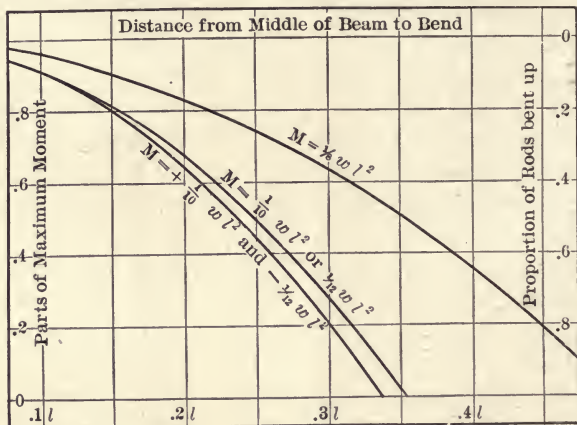

FIG. 38.

in Fig. 38 may be plotted and are to be used in finding the points at which any number of rods may be dispensed with, in the tension side, and bent up for web reinforcement. For example, let the reinforcement consist of 2 one-inch, 2 seven-eighth-inch, and 2 three-quarter-inch rods, arranged symmetrically with the larger ones outside. The whole cross area of the steel is, then, from page 156, 3.657 square inches. The pair in the middle of the breadth, to be bent up nearest the middle of the beam, have an area of 0.8836 square inches or 0.24 of the whole. Hence, where the bending moment is but 0.76 of the maximum, the other four rods are sufficient to provide for it. In Fig. 38, for  $M = \frac{1}{2} w l^2$ , it is seen that 0.24 of the area of the rods may be bent up at a point  $0.17 l$  from the middle. The other two rods to be bent up have an area of 1.203 square inches, or there will be left 1.57 square inches or 0.43 of the whole. In Fig. 38 it is seen that 0.57 of the steel may be bent up at  $0.27 l$  from



the middle. The two outside rods run the whole length of the beam. Usually the rods are continued a little farther than the minimum distance, bent up to a point near the top of the beam and again bent to a horizontal position, where they become tensile reinforcement to resist the negative moment near the supports. This method is not quite accurate since the resisting moment of a beam does not vary directly as the amount of reinforcement. However, the above process makes the stress in the rods nearly constant but decreasing from the middle, while the stress in the concrete is also decreased from that at the middle, but not directly with the bending moment.

As determined by (2),  $u = V \div moj$ , a certain number of rods must always run to the ends of a beam whether they are needed to resist flexure or not.

**Beams not Requiring Web Reinforcement.** Most reinforced concrete beams of rectangular cross-section are in the form of comparatively thin and wide slabs. These slabs frequently form the flanges of T-beams, and, as such, are entirely in compression, but between the T-beams they act as simple beams. Unless the slabs are of unusual depth the concrete may be able to take all the diagonal stresses, and stirrups may be unnecessary. It may be readily ascertained whether or not this is the case when the depth and span are known. From (16), page 40,  $M = N_1 C b d^2$ , and, for uniform loading,

$$c w l^2 = N_1 C b d^2.$$

Also

$$V = \frac{1}{2} w l$$

or

$$v = \frac{w l}{2 b j}$$

combining,

$$\frac{l}{\bar{d}} = \frac{N_1 C d}{2 c v j} \quad (65)$$

in which  $c$  is the coefficient depending upon the way in which the ends of the beams are fixed. For a simple beam  $c$  is  $\frac{1}{8}$ . If  $j$  be  $0.875 d$ ,  $v$  be 40,  $S_t$  be 16,000, and  $C$  be 650 pounds per square inch,  $N_1$  is 0.166 from Plate I, and

$$\frac{l}{\bar{d}} = \frac{1.54}{c} = 12.3 \text{ for simple beams.}$$

If  $c$  be  $\frac{1}{10}$ ,  $l/\bar{d} = 15.4$ , and for  $c = \frac{1}{12}$ ,  $l/\bar{d} = 18.5$ .

For concrete of strength such as assumed, stirrups must

therefore be provided if the length be not more than  $12.3 d$  for simple beams, and  $15.4 d$  or  $18.5 d$  for beams having ends partially or entirely fixed.

**Bond Stresses in Web Reinforcement-stirrups.** It is evident that for economy of design the bond between the web reinforcement and the concrete should be equal to the strength of the rods. As was shown on page 25, the length of grip of the rod should be

$$x = d_1 S_t \div 4 u.$$

Substituting the value of  $S_t$  from (87) this becomes

$$x = \frac{V's}{\pi d_1 j m u} \quad (66)$$

in which  $m$  is the number of stirrups in the area  $bs$ . It will be noted that  $x$  varies inversely as  $d_1 m$ . This expression applies to square bars if 4 be substituted for  $\pi$ . For ordinary working values,  $s$  may be taken as  $\frac{3}{4} d$ ,  $j$  as  $.875 d$ , and  $u$  from 75 to 80 pounds per square inch of contact between steel and concrete, then for round rods

$$x = \frac{0.273 V'}{d_1 m u} \text{ or } x = \frac{0.215 V'}{d_1 m u} \text{ for square bars} \quad (67)$$

$$\text{or } x = \frac{0.0035 V'}{d_1 m} \text{ or } x = \frac{0.0028 V'}{d_1 m} \text{ for square bars} \quad (68)$$

In this expression  $V'$  is the vertical shear not taken by the concrete. If  $V$  be the shear due to loads the value of  $x$  is

$$x = \frac{.0035 (V - 35 bd)}{d_1 m} \text{ for rods} \quad (69)$$

$$= \frac{0.0028 V}{d_1 m} \text{ for bars} \quad (70)$$

When the safe shearing strength of the concrete is 40 lb. per sq. in., and that of the whole beam 120 lb. per sq. in., or when  $V'$  is  $\frac{2}{3} V$ ,

$$x = \frac{0.0023 V}{d_1 m} \text{ or } x = \frac{0.0018 V}{d_1 m} \text{ for bars.}$$

When the stirrups are vertical the length is limited by the depth of the beam. Since the tension side of the beam is apt to contain many fine vertical cracks it is not reasonable to expect full bond strength throughout the entire depth. Experiments

show that it is safe to assume the grip of a rod to be  $\frac{6}{10}$  of its length in computing bond strength.

In designing, all the factors in (66) are generally known or assumed except  $d_1$  and  $m$ , the product of which may be found from the same equation:

$$\begin{aligned} md_1 &= \frac{0.0035 V'}{x}, \text{ or for squares } \frac{0.0028 V'}{d} \\ &= \frac{0.006 V'}{d}, \text{ or for squares } \frac{0.0046 V'}{d} \\ &= \frac{0.006 (V - 35 bd)}{d} \text{ for round rods} \\ &= \frac{0.0046 (V - 35 bd)}{d} \text{ for square bars} \end{aligned}$$

$$\text{and } md_1 = \frac{0.004 V}{d}, \text{ or for squares } \frac{0.003 V}{d} \quad (71)$$

when the concrete takes  $\frac{1}{3}$  and the stirrups take  $\frac{2}{3}$  of the vertical shear. If rods of several sizes be used  $md_1$  is the sum of the diameters.

For example, let it be required to reinforce a beam against diagonal tension when  $b$ ,  $d$ , and  $l$  are 10 inches, 20 inches, and 10 feet respectively, and the uniform load is 2000 lb. per linear foot. The maximum shear is  $2000 \times 5 = 10,000$  pounds. The concrete will take  $35 \times 10 \times 20 = 7000$  pounds, hence,  $V'$  is 3000 pounds. Then  $md_1 = .006 \times 3000 \div 20 = 0.9$  inch, or 4 quarter-inch rods. At the ends the spacing will be not greater than  $s = 14,000 \times 0.25 \times 20 \div 3000 = 23$  inches, but  $s$  is otherwise limited to  $\frac{3}{4}$  of  $20 = 15$  inches. If two half-inch rods be used,  $s$  is computed to be 47 inches, which arrangement is less economical. By using even smaller rods the computed value of  $s$  could be made to agree with the specified limit,  $\frac{3}{4} d$ ; such sizes are, however, unusual for this purpose. The next stirrups are 15 inches nearer the middle, where they carry but 500 pounds of shear and but two rods need be used.

**Bond Stresses in Bent-up Rods.** If the above expressions for  $x$  and  $d_1 m$  be multiplied by  $\sin \alpha$ , they will apply to rods inclined at that angle with the horizontal. Usually the only case of inclined web reinforcement is that of the bent-up bars



of the horizontal reinforcement. In order that they may be bent up at frequent intervals, the rods should be small and numerous rather than large and few, which arrangement also provides better bond.

**Transverse Spacing of Reinforcement.** In order that there shall be beam action it is necessary, not only that there be perfect bond between the steel and the adjacent concrete, but also that the steel and adjacent concrete shall not shear away from the remainder of the concrete. This condition requires that the bond between the steel and the concrete be equal to the shearing strength of the concrete between the rods. Only the bond on the surface of the rod above the plane of least concrete is effective in causing shear in that plane, the bond on the remainder of the rod being exerted upon the concrete below. Thus in (a), Fig. 39,  $\frac{1}{2} \pi d_1 u = s S_s$ , in (b),  $d_1 u = s S_s$ , and in (c),  $2 d_1 u = s S_s$ . As the shearing strength of concrete may be safely taken at more than three halves that of bond, the values of  $s$  in the

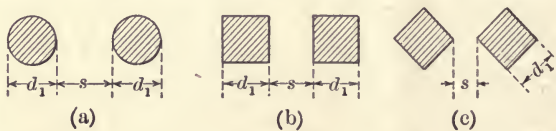

FIG. 39.

above expressions become  $1.05 d_1$ ,  $0.7 d_1$ , and  $1.33 d_1$ . The last is an unusual ar-

angement, and if the diagonal instead of the side be taken as the thickness of the bar, the clear width of the concrete will be 0.94 times the diagonal.

The reinforcement is usually put in place within the forms before the concrete is poured, and it is essential that enough space be left between the rods to allow the concrete to entirely surround the steel and to fill the forms. Between the steel and the outside of the beam the concrete acts as a protection to the reinforcement against fire and dampness. For these purposes it is not possible to prove very definitely the thickness needed, but the recommendations of the Joint Committee represent usual practice. See page 144.

**Working Rule for Transverse Spacing of Reinforcement.** The recommended practice is given on page 150, and, in designing beams, the width must accordingly be, at least,

$$b = (1.5 + 2.5 n) d_1,$$



Where  $n$  is the number and  $d_1$  the thickness of the rods. In addition there must be a width of at least

$$b = 4 + 2.5 (n - 1) d_1 \text{ for girders,}$$

or 
$$b = 3 + 2.5 (n - 1) d_1 \text{ for beams.}$$

For ultimate strength of the beam, a greater width may be of advantage since adhesion to the horizontal rods is partly destroyed and the strength is largely dependent upon the anchorage at the ends. This anchorage may be more effectual as the width of the beam is increased.

**The Inclination of Bent-up Bars.** At a point in a beam where the bending moment has decreased from the maximum sufficiently to allow a part of the horizontal rods to be dispensed with, they may be (a) discontinued, (b) turned over to form a hook, or (c) continued diagonally upward toward the top of the beam. The first alternative is not desirable as the bond in the concrete near the middle of the beam is not as good as would be the case near the end where the moments are smaller. Also, when a part of the bars are discontinued the stress in those remaining becomes immediately increased, which fact impairs the bond between the steel and the concrete. This latter objection applies also to the anchoring of the rods at such points by hooks. Usually the rods are bent up to form diagonal reinforcement. This arrangement is desirable for several reasons: the horizontal components of the upturned bars act with those unbent in taking the tension due to bending, and so the resisting moment is decreased gradually, as it should be. Again, such a rod, being rigidly attached to the horizontal part and extending into concrete in compression, is in the best possible position to offer resistance to diagonal tension, and is put in place with less extra expense than is a detached diagonal member and an anchorage for the horizontal rod.

The horizontal stress in a rod is, at the bend, transferred to the concrete as compression, and if the bend be too abrupt, the unit stress may become excessive. In Fig. 40  $r$  is the radius of the curve around which the rod is bent, and the compression stresses may be represented by some such figure as is shown in the

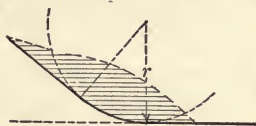

FIG. 40.

shaded part. If the length of the curve over which the rod exerts compression be assumed to be  $r$  and the unit compression be  $C$ ,

$$Crd = \pi d^2 S_t \div 4$$

$$r = 0.7854 d S_t \div C \quad (72)$$

The rod is imbedded in the concrete and the compression is exerted over but a small part of the whole cross-section. Also the concrete is normally in tension, and, for these reasons, a relatively high stress, as 1000 lb. sq. in., may be assumed for the value of  $C$ . If the working strength of the steel be taken as 16,000 pounds per square inch, the stress at the point where the bend occurs will seldom be more than three-fourths of this, or 12,000 lb. sq. in. In any given case the stress may be computed. Substituting these values of  $S_t$  and  $C$  in the above expression,  $r$  becomes

$$r = .7854 \times 12,000 d \div 1000 = 9.4 d.$$

If the arc in compression be taken as  $45^\circ$ ,  $r$  becomes  $12 d$ . As cracks following the line of the rod are seldom seen in tests of beams having even sharper bends in the reinforcement, it may be assumed that curves such as indicated will be satisfactory.

**Waterproofing and Fireproofing Qualities of Concrete.** As the tension side of a beam is liable to contain small cracks extending past the reinforcement, it may be questioned whether or not the imbedded steel is apt to become rusty and subject to corrosion from moisture and other causes. Most of the tests and observations in this connection have been made on steel imbedded in large blocks of concrete, and kept alternately under water and in air for various periods of time. These tests usually fail to show any marked effect of the water upon the steel where there has been perfect union between the metal and the concrete. In general, rusting occurs only under the combined action of moisture and carbonic acid. The preserving quality of concrete is then dependent upon its ability to exclude one of these agents from contact with the steel. In the case of large blocks of concrete under compression the reinforcement may be perfectly protected by the fact that the concrete is

water-tight. In the tension sides of beams, however, there are always some cracks which may become filled with moist, smoky air, and conditions favorable to the formation of rust may result if the metal be exposed. As concrete contains a large proportion of lime, it readily absorbs and neutralizes the carbonic acid, and effectually protects the steel if it completely covers the latter with even a thin film. In order that this film may be continuous the concrete should be mixed wet, and should contain enough fine material to render it dense. Bars taken from such concrete usually have a coating of that material that is removed only by considerable friction, and the conclusion is that imbedded steel is not liable to rust even when the unit stress in it approaches the elastic limit. Several references to tests concerning this subject are noted below.<sup>1</sup>

The Baltimore and San Francisco fires and numerous smaller conflagrations have afforded opportunities for the study of the effect of great heat on concrete structures, as they are usually built. In addition, some tests have been conducted with heat at a known intensity, and other causes and effects more accurately determined than can be the case in a burning building. As concrete in its manufacture has passed through a period of intense heat it suffers but little from the further application of high temperatures. There was, however, some question as to the effect of the concrete in preserving the reinforcing steel from surrounding fire.

The fireproofing qualities of concrete seem to be due to the fact that it is, of itself, not inflammable, and also to the fact that it is a poor conductor of heat. The mixture in setting combines chemically with quite a large proportion of water which is vaporized by heat and has a decidedly cooling effect; and the material so changed has a lower thermal conductivity than before. All concrete is somewhat porous and, the entrained air being of very low conductivity, this fact adds further protection to the metal. In this respect cinder concrete seems somewhat better than that made of the purer quartz sands.

Both the experimental tests and observations of results of large fires have been fully reported and only the summary of

<sup>1</sup> *Engineering Record*, Vol. LVII, page 105; *Proc. Am. Soc. Testing Materials*, Vols. V, VI, and VII; *Engineering News*, August, 1904, June 16, 1904, page 561.



conclusions need be given here.<sup>1</sup> The conclusions to be drawn are that sharp corners of columns and beams are more susceptible to attack than wide, flat surfaces, such as slabs. Ample protection seems to be afforded by 2 to 2½ inches and ¾ to 1 inch of concrete in the two cases respectively. Only the steel in actual contact with the flame seems to be affected. In the first reference below it is reported that 1500° Fahr. for two hours at the surface of a plate resulted in only 500° to 700° Fahr. 2 inches under the surface, while at 3 inches below the temperature was 212° Fahr. Also, the temperatures of a bar protruding into a temperature of 1700° Fahr. were 1000° at 2 inches, 500° at 5 inches, and 212° at 8 inches inside the surface.

In extreme cases reinforced concrete buildings may be rendered valueless by fire, but the destruction will be accomplished very slowly.

**Temperature Stresses.** When concrete structures, such as long retaining walls, arches, and spandrel walls, and continuous or fixed beams, are subjected to changes of temperature, they will tend to increase or decrease in length according to a known law. If the resulting stresses be sufficient, the concrete will be cracked at points of least strength. As the strength of concrete is much less in tension than in compression, the results of a fall in temperature are more serious, usually, than in case of a rise. The problem of reinforcing for temperature stresses is not at all to prevent cracks, but only to cause their uniform distribution along the entire length of the structure, thus keeping the width of any one within desired limits. The coefficient of contraction of dense concrete such as is used in important work, has been determined<sup>2</sup> with considerable accuracy, and may be taken as .0000055. The range of temperature in concrete is not nearly that of the atmosphere, and a drop of 50° Fahr. is, perhaps, all that need be allowed for. As the coefficient of expansion of steel, 0.0000065, differs but slightly from that of concrete, and as the steel is somewhat protected by the covering of concrete, little error will result from assuming equal change in length in the two substances.

<sup>1</sup> See *Proc. Am. Soc. Civil Engineers*, Vols. 51, 55 and 59. *Cement*, May, 1902, page 95; *Eng. News*, October, 1902, page 334; January, 1904, page 30, March 24, 1904. *Insurance Engineering*, 1901, page 483. *Engineering Record*, April 12, 1902, page 341.

<sup>2</sup> *Journal Western Soc. Eng.*, Vol. VI, page 49.



If  $D$  be the drop in temperature from normal the contraction is  $0.0000055 Dl$ . If the tensile strength of concrete be 300 lb. sq. in., and  $E$  be 2,000,000, the whole elongation is

$$\lambda = \frac{Pl}{AE} = 0.0000055 Dl$$

and

$$D = 27^\circ,$$

so cracks will occur in concrete at some particularly weak spot on the surface when the temperature is lowered by this amount. With increasing cold the cracks become deeper till the steel is reached. Here there can be no opening of the crack until the bond between the concrete and the steel is impaired. As the bond at the crack loosens, the concrete slips back, the bar stretches and its cross-area becomes smaller. This action impairs or breaks the bond farther back, and the bar stretches over the space  $y$  on each side of the crack, as in Fig. 41, till equilibrium is established between the stress and the bond. Beyond this point the steel and concrete contract equally, as the bond is perfect over the spaces  $x$ , which extends to a

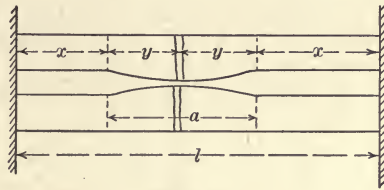

FIG. 41.

point  $y$  distant from the next crack or to the immovable wall as shown. If there be but one crack in the distance  $l$ , the tensile strength of the concrete section and of the bond are equal. As the unit tensile and bond stresses are practically equal, or may be determined for any particular case, an equation may be written:  $2x\pi d_1 u/2 = AS/p$ , or  $4pAux = ASd_1$ , where  $AS/p$  is the tensile strength of the concrete and  $u$  is somewhat less than the ultimate unit bond strength. The bond stress in the distance  $x$  decreases from  $u$  to nearly zero at the wall, and the average is  $u/2$  for this distance, then if  $p$  be the ratio of steel to concrete area and  $d_1$  the diameter of the rod or the thickness of the bar,

$$p = \frac{d_1}{4x}$$

The contraction in the rod in the space  $x$  is the same as the expansion in the distance  $y$ , as  $l$  is constant, each being  $.0000055$

$Dx$ , or, if  $D$  be  $50^\circ$ ,  $y = .000275 x$ . If the elastic limit of steel be 33,000 lb. sq. in.,

$$.000275 x = \frac{33,000 y}{E}$$

and  
also

$$x = 4 y,$$

$$2 x + 2 y = l$$

$$x = \frac{l}{2.5}$$

so

$$p = \frac{d_1}{1.6 l} \quad (73)$$

The constants will vary somewhat for different concretes, but it will be noted that the distance between cracks is inversely

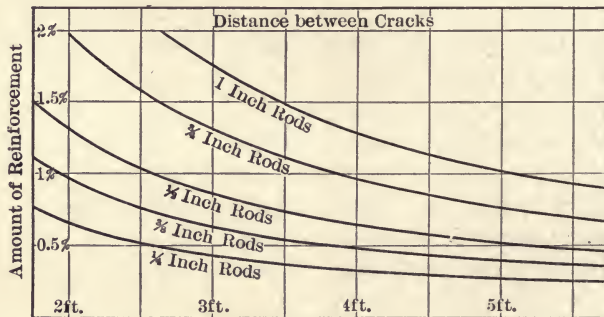

FIG. 42.

proportional to the amount of reinforcement. Also, that, for economy, the reinforcement should be made up of small rods, while no amount of reinforcing will prevent cracks or diminish their aggregate width, which will always be  $\Delta D l$ , when  $\Delta$  is the coefficient of expansion. Fig. 42 is plotted from (73) for several sizes of rods, either square or round.

For example, let the railing of a bridge be 300 feet long and fixed at the ends. The contraction due to  $50^\circ$  fall in temperature will be  $.0000055 \times 50 \times 300 \times 12 = 0.99$  inches, which amount will be the sum of the widths of all the cracks. If there be 99 cracks, each 0.01 inch wide,  $l$  in (73) will be 3 feet, and from Fig. 42 the required amount of reinforcement is found to be 0.44 per cent. for  $\frac{1}{4}$ -inch rods, or 0.88 per cent. for half-inch rods. If 0.5 per cent. of half-inch rods be used, the cracks will

be 5.2 feet apart and the width of each will be  $0.99 \times 5.2 \div 300 = 0.017$  inches.

If the concrete contracts in hardening, cracks will result if the tensile strength be exceeded by the resulting stress. As the steel is otherwise unstressed it will resist contraction of the concrete and be in compression where the bond is intact, and in tension where the bond is destroyed, as it is near the cracks. As the coefficient of contraction during hardening, is uncertain, the same analysis as above cannot be employed, but the whole amount of reinforcement necessary may be determined. As before, the unit tensile and bond strengths may be assumed to be practically the same, and, for equilibrium, the strength of the concrete cross-section will equal that of the steel. The average stress in the concrete will be half the ultimate, as it varies from that amount to zero after the cracks occur. Before the concrete is thoroughly set the tensile strength will be small, perhaps not over 150 lb. sq. in., and the elastic limit of the steel may be taken as 33,000 lb. sq. in. as above. Then  $\frac{1}{2} \times 150 A = pA \times 33,000$  and  $p = .0023$ . As there is much uncertainty concerning the strength of concrete during this stage of hardening this result is only approximate.

**Working Rule.** It is the common custom to insert about  $\frac{1}{3}$  of one per cent. of reinforcement near the surface of a wall to provide for cracks due to temperature and to hardening, using small rods for the purpose. If the structure be fixed in two directions the reinforcement must be placed accordingly.

### PROBLEMS

37. A simple beam of 20 feet length is 12 inches wide and 24 inches deep. It carries, including its own weight, a load of 1200 lb. per linear foot. Find the size and spacing of the stirrups, allowing 30 lb. sq. in. as the maximum shearing stress in the concrete.

38. If the above beam be reinforced with four  $\frac{1}{8}$  inch square bars, at what point may the two inside ones be bent up?

39. What uniform load will the beam in the last problem carry safely without stirrups?

40. Prove the formulas for transverse spacing of reinforcing rods given on pages 82 and 83.

41. How will Fig. 41 be changed if the tension in the steel be assumed to decrease gradually from the elastic limit at the crack to zero, where the bond is perfect?

42. Prove that vertical or diagonal reinforcement tends to diminish the tension in the lower horizontal steel.



**Combined Flexural and Axial Stresses in Beams.** Such combinations of stresses may occur in beams confined between

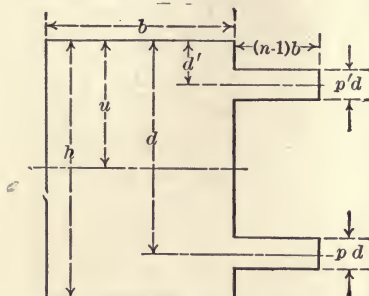

FIG. 43.

walls, in columns, dams, retaining walls, and arch rings. The bending moment may result from lateral pressure or it may be due to the eccentric application of the stresses in the direction of the axis.

While not practically true, theoretically the same condition of stiffness in a section may be secured by substituting for the reinforcing steel  $n$  times its area of concrete at the same distance from the neutral axis as was the steel. Fig. 43 shows the concrete added to one side forming what is known as the transformed section. The area of the transformed section is

$$A_t = A_c + (n - 1) (A + A')$$

in which  $A_c$  is the area of the concrete section  $bh$ ,

$$I_t = I + (n - 1) I_s,$$

in which  $I_t$ ,  $I$ , and  $I_s$  are the moments of inertia of the transformed section, of the concrete section  $bh$ , and of the steel respectively, about the gravity axis of the concrete section.

If the section be rectangular the distance from the upper fiber to the center of gravity is

$$u = \frac{h^2/2 + (n - 1) / b (Ad + A'd')}{h + (n - 1) / b (A + A')} \quad (74)$$

and 
$$I = b/3 [u^3 + (h - u)^3]. \quad (75)$$

Since  $p^3$  is small,

$$I_s = A (d - u)^2 + A' (u - d')^2 \text{ nearly.} \quad (76)$$

If, as in (a), Fig. 44 the resultant,  $R$ , of forces on one side of a section pierce the section at a point outside the gravity axis, bending will result. The resultant may be resolved into forces perpendicular and parallel to the section, as  $H$  and  $V$ . The former is the normal force causing flexure, and the latter is the

shear. If  $R$  be applied a distance,  $e$ , from the gravity axis, the bending moment is

$$M = He$$

$$\text{and } C = \frac{H}{A_c + (n-1)(A + A')} + \frac{Heu}{I + (n-1)I_s} \quad (77)$$

$$\text{also } C' = \frac{H}{A_c + (n-1)(A + A')} - \frac{He(h-u)}{I + (n-1)I_s} \quad (78)$$

The maximum or minimum fiber compression is, thus, due to the uniform load,  $H$ , over the entire section and to the bending. In Fig. 44 the stress diagram for uniform load alone would be rectangular and of the width shown on  $xx$ , the gravity axis. The difference between such a diagram and the one shown would be the stress diagram for bending alone.

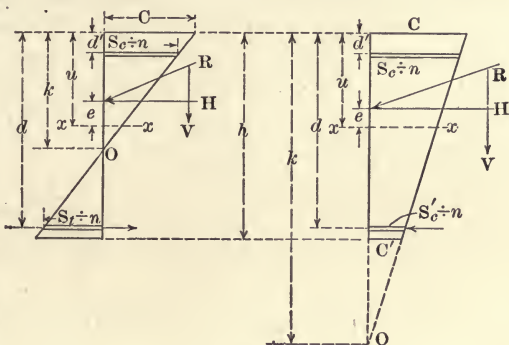

FIG. 44.

The unit stress in the steel is  $n$  times that in the concrete fibers at the same distance from the axis; so if the steel be located as shown in the figure,

$$S_c = n \left[ \frac{H}{A_c + (n-1)(A + A')} + \frac{He(u-d')}{I + (n-1)I_s} \right] \quad (79)$$

and

$$S'_c \text{ or } S_t = n \left[ \frac{H}{A_c + (n-1)(A + A')} - \frac{He(d-u)}{I + (n-1)I_s} \right] \quad (80)$$

where  $S_c$  is the stress in the steel on the same side of the axis as  $H$ , and  $S'_c$  in (a), and  $S_t$  in (b), refer to steel on the opposite side.

These formulas are general, whatever the form of the cross-section, and whatever the eccentricity may be, and are readily applied when numerical values of the factors are substituted. When the eccentricity is so great that concrete in tension becomes cracked, the effective area of the concrete is no longer  $bh$ , while

$I$  and  $u$  become variable. In this case the above formulas are not readily applied and others will be deduced later. This case occurs when the value of  $C'$  in (78) becomes negative and will be called Case II.

**Case I. Rectangular Section with Symmetrical Reinforcement, all in Compression.** In very many instances the section considered is rectangular, and the above formulas may be made more simple when numerical values are substituted. In designs wherein compression extends over the entire section, the reinforcement is frequently placed, in equal amounts, at the same distances from the outer fibers on either side. Here the transformed section is symmetrical about the axis, midway between the top and bottom,  $u = \frac{1}{2} h$  and  $I$  may be taken as  $\frac{1}{12} bh^3$ . As already defined,  $2p$  is the area of the steel divided by the effective area of the whole section, so  $2p = (A + A') \div bh$ . Making these substitutions

$$C = \frac{H}{bh} \left( \frac{1}{1 + 2(n-1)p} + \frac{6eh}{h^2 + 24p(n-1)(u-d')^2} \right) \quad (81)$$

$$C' = \frac{H}{bh} \left( \frac{1}{1 + 2(n-1)p} - \frac{6eh}{h^2 + 24p(n-1)(u-d')^2} \right) \quad (82)$$

$$S_c = \frac{nH}{bh} \left( \frac{1}{1 + 2(n-1)p} + \frac{12(u-d')e}{h^2 + 24p(n-1)(u-d')^2} \right) \quad (83)$$

$$S'_c = \frac{nH}{bh} \left( \frac{1}{1 + 2(n-1)p} - \frac{12(u-d')e}{h^2 + 24p(n-1)(u-d')^2} \right) \quad (84)$$

If the value of  $e$  be such that  $C'$  is more than the safe stress for concrete in tension, formula (82) does not apply, and the computation must be made under Case II.

**Diagram for Case I.** If values be assumed, for  $n = 15$  and for  $u - d' = 0.4h$ , the formulas become

$$C = \frac{H}{bh} \left( \frac{1}{1 + 28p} + \frac{e}{h} \frac{6}{1 + 53.8p} \right) = N_6 \frac{H}{bh} \quad (85)$$

$$C' = \frac{H}{bh} \left( \frac{1}{1 + 28p} - \frac{e}{h} \frac{6}{1 + 53.8p} \right) = N'_6 \frac{H}{bh} \quad (86)$$

$$S_c = \frac{H}{bh} \left( \frac{15}{1 + 28p} + \frac{e}{h} \frac{72}{1 + 53.8p} \right) = N''_6 \frac{H}{bh} \quad (87)$$



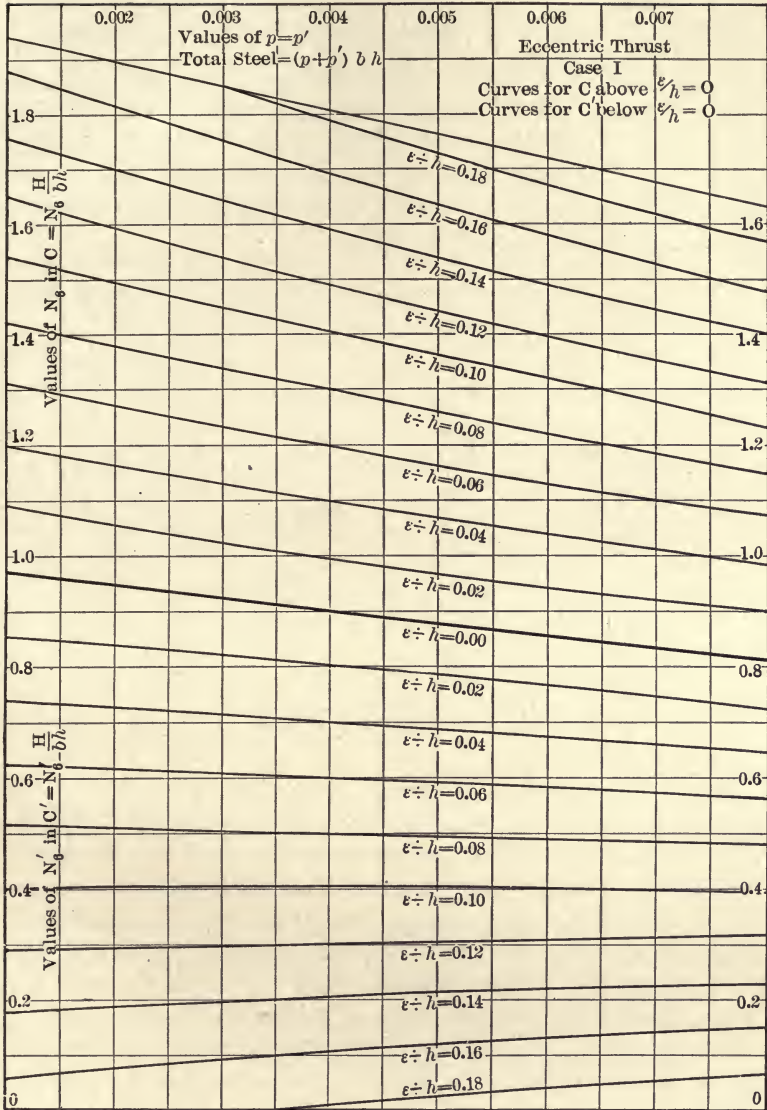

PLATE VIII.

$$S_c' = \frac{H}{bh} \left( \frac{15}{1 + 28p} - \frac{e}{h} \frac{72}{1 + 53.8p} \right) = N_6''' \frac{H}{bh} \quad (88)$$

where  $p$  is half the total amount of steel in the whole section.

Values of  $C$  and  $C'$  are plotted on Plate VIII, and of  $S_c$  and  $S_c'$  on Plate IX, the diagrams extending only over such values of  $e \div h$  as being the problem under Case I. It is apparent that  $C$  is the critical value, as it is always greater than  $C'$ , and also greater than  $S_c/n$ . In the diagram  $p$  is, for convenience, the proportion of steel at each edge.

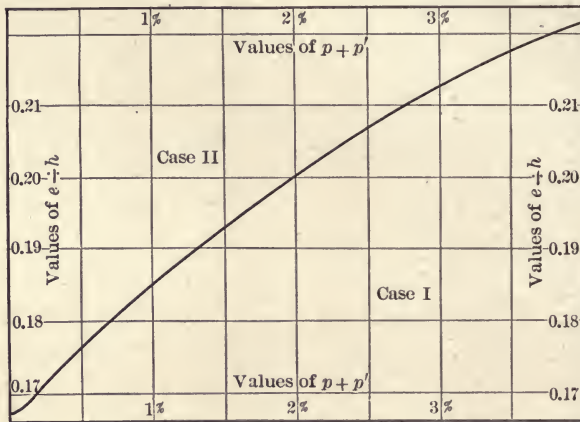

FIG. 45.

Fig. 45 shows the curve separating Case I from Case II. For example, if  $p + p'$  be  $\frac{1}{2}$  of 1 per cent., values of  $e \div h$  under .177 indicate Case I, and larger values Case II.

If the rectangular section be that of a column, free to bend in any direction, the denominator in  $e/h$  is not necessarily the longer of the two axes, but the fraction must, for safe design, be the larger of the two values,  $e/h$  and  $e/b$ . In the case of a beam, eccentricity in the direction of the shorter dimension of the section is not usually considered, since a floor or other bracing is usually attached in such manner as will prevent lateral flexure.

**Case II. Tension and Compression in the Section.** The formulas in Case I apply when there are small tensile stresses in the concrete such as will not cause cracks. When the latter





fraction within the parenthesis of (82) becomes larger than the first,  $C'$  changes sign and the numerical value indicates the unit tension in the concrete.

In Fig. 46 all the tension is assumed to be in the steel. Then for equilibrium in a rectangular section

$$\frac{bCk}{2} + A' \left( S_c - C \frac{k-d'}{k} \right) - AS_t = H \quad (89)$$

$$\frac{bCk}{2} \left( u - \frac{k}{3} \right) + A' \left( S_c - C \frac{k-d'}{k} \right) (u-d') + AS_t (d-u) = M \quad (90)$$

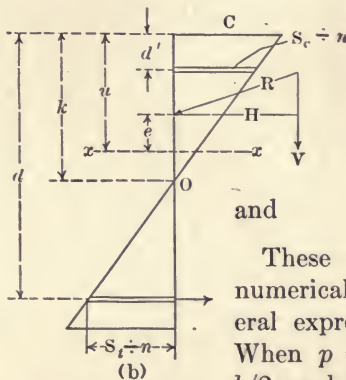

FIG. 46.

the center of moments being at the gravity axis of the section.

Because of the conservation of plane sections

$$C : S_t \div n = k : d - k$$

$$C : S_c \div n = k : k - d'$$

and

These equations may be solved when numerical values are inserted, but the literal expression for  $k$  is quite complicated. When  $p = p'$  and  $d' = h - d$ ,  $u$  becomes  $h/2$ , and the expressions may be made more simple. With some approximations, a formula involving  $k$  may be written after multiplying (89) by  $e$

and equating it to (90).

$$k^3 - 3k^2 \left( \frac{h}{2} - e \right) + 12kenph - 6pn(eh^2 + 2u_1^2h) = 0 \quad (91)$$

where  $u_1$  is  $h/2 - d'$  and  $e$  is the eccentricity of the point of application of the external forces. The value of  $k$  may be found by trial, or, when  $n = 15$  and  $u_1 = \frac{1}{10}h$ , in Plate X. After  $k$  is found the stresses may be determined for given values of  $H$  or  $M$  and  $e$ .

$$C = \frac{2Hk}{bk^2 + 2pbhn(2k-h)} \quad (92)$$

$$S_t = nC \frac{2u_1 + h - 2k}{2k} \quad (93)$$

$$S_c = nC \frac{2u_1 - h + 2k}{2k} \quad (94)$$

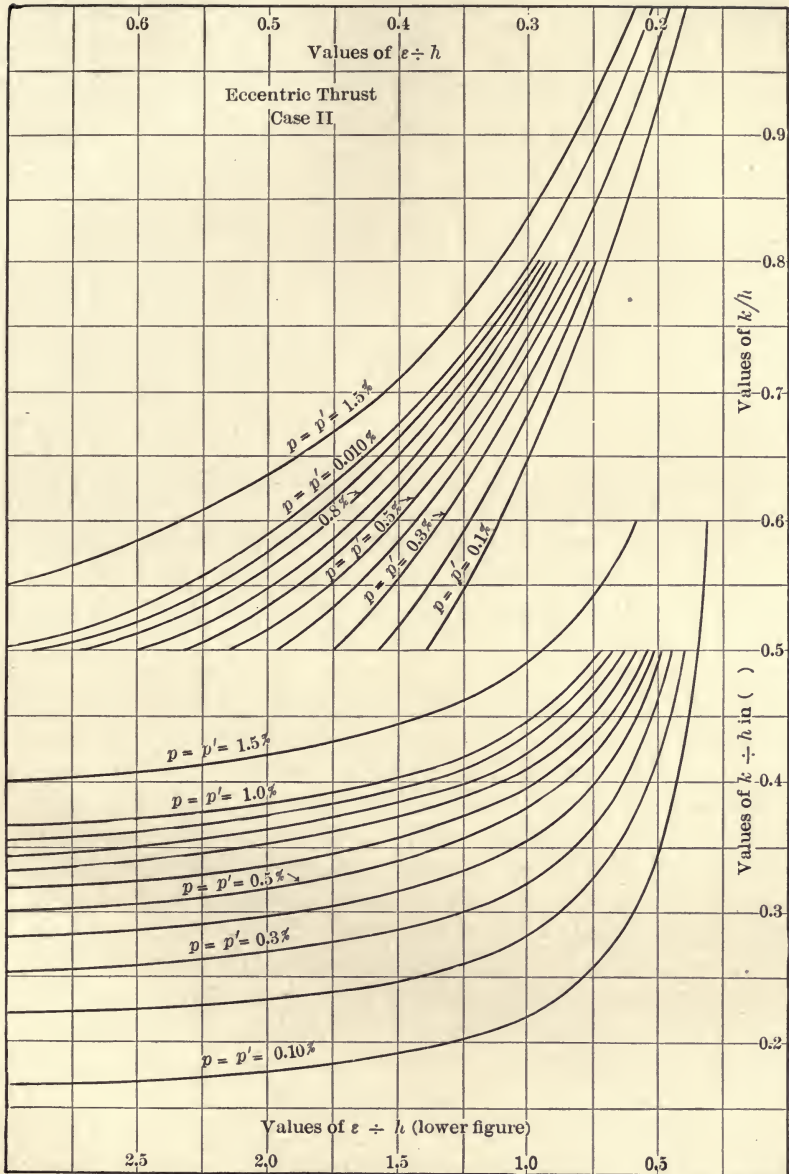

PLATE X.

If the reinforcement be placed  $h/10$  from the upper and lower edges,  $pbh$  at each point,  $u_1 = .4h$ , and the last three formulas reduce as follows:

$$C = \frac{2 Hk}{bk^2 + 30 pbh (2k - h)} \quad (95)$$

$$Cr = S_t = 15 C \frac{.9h - k}{k} \quad (96)$$

$$Cr' = S_c = 15 C \frac{k - .1h}{k} \quad (97)$$

$$r = 15 \frac{.9h - k}{k} \quad (98)$$

also 
$$M = \frac{e}{h} \left( \frac{k}{2h} + 30p - 15 \frac{ph}{k} \right) Cbh^2 \quad (99)$$

$$= N_7 Cbh^2 \quad (100)$$

In these formulas  $p$  is the reinforcement at both top and bottom of the beam, and is, hence, half the whole. Also, since these equations and those of Case I are intimately connected,  $p$  is  $A \div bh$  rather than  $A \div bd$ . In plotting values of  $k$  in Plate X, or in extending the same if desired, it is much simpler to assume  $k$  and solve for  $e/h$  since this factor is less involved than is  $k$ .

For example, to illustrate the use of Plates VIII–XI and the formulas upon which they depend, let the depth of an arch ring be 15 inches, and let the resulting pressure be 6000 pounds for each inch in length. If the reinforcement be .0075 at  $h/10$  from intrados and extrados, and the resultant pressure be applied 2 inches from the middle, and at an angle of  $5^\circ$  with the right section, what will be the unit pressure in the concrete at each edge and in the inner and outer steel? Here  $e/h$  is  $2 \div 15 = 0.133$ , and, by Fig. 45, the problem falls clearly in Case I. The normal pressure,  $H$ , for 1 inch of breadth is  $6000 \times \cos 5^\circ = 5976$ , and the moment is  $5976 \times 2 = 11,952$  lb. in. By formula (85), or by the diagram in Plate VIII,

$$C = \frac{5976}{1 \times 15} \left( \frac{1}{1 + .14 \times \frac{3}{2}} + .133 \frac{6}{1 + .269 \times \frac{3}{2}} \right) =$$

$$\frac{5976}{15} \times 1.39 = 560 \text{ lb. sq. in.}, C' = \frac{5976}{1 \times 15} \times .256 = 104 \text{ lb. sq. in.}$$



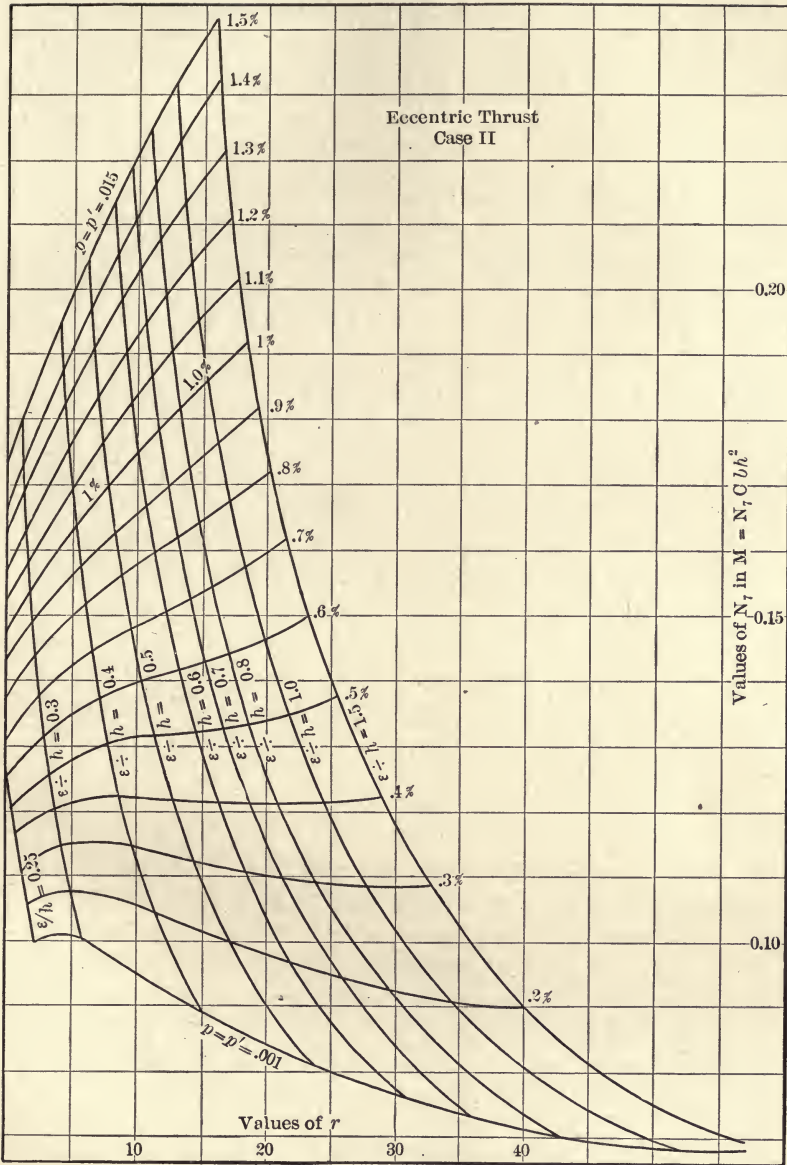

PLATE XI.

In the lower part of Plate VIII, the factor .256 is taken directly.

$$S'_c = \frac{5976}{15} \left( \frac{15}{1.21} + \frac{9.6}{1.404} \right) = 7660 \text{ lb. sq. in.}$$

and 
$$S'_c = \frac{5976}{15} \times 5.6 = 2230 \text{ lb. sq. in.}$$

The factors for the stress in the steel are found in Plate IX.

Let the following assumptions be made:  $b = 8$  inches,  $h = 35$  inches,  $A = A' = 1.12$  square inches,  $M = 520,000$  lb. in.,  $n = 15$ , and reinforcement placed symmetrically. If the moment be caused by an axial load of 29,000 pounds, it is required to find the stresses in the concrete and in the steel. The percentage of reinforcement is .4, and the eccentricity is  $520,000 \div 29,000 = 17.9$  inches. A reference to Fig. 45 shows that the problem belongs to Case II and in Plate XI, for  $p = 0.4$  per cent. and  $e/h = 0.512$ ,  $N_7$  is found to be 0.122. Then  $C = 520,000 \div (.122 \times 8 \times 35^2) = 433$  lb. sq. in. At the bottom of Plate XI,  $r$  is found to be 14, and from (97)  $r'$  is 11.7, so  $S'_t = 433 \times 14 = 6060$ , and  $S_c = 433 \times 11.7 = 5100$  lb. sq. in.

A beam is 14 inches wide and 24 inches deep. The bending moment is 525,000 lb. in., and the eccentricity is 8 inches. If the working strength of the concrete be 600 lb. sq. in., how should the beam be reinforced. Here the eccentricity ratio is  $8 \div 24$ , and Fig. 45 shows the problem to be one for the application of Case II for any value of  $p$  there given. In Plate XI,  $N_7 = 525,000 \div (600 \times 15 \times 24 \times 24) = 0.109$ . At the intersection of this value of  $N_7$  and  $e/h = 0.3$ ,  $p$  is seen to be 0.24 per cent., which is also the value of  $p'$ .

In the last example let  $e/h$  be changed to  $\frac{1}{6}$ , involving Case I, as shown by Fig. 45.  $N_7 = 600 \times 24 \times 14 \times 24 \div 525,000 = 1.54$ . In Plate VIII this factor, with  $e/h = \frac{1}{6}$ , calls for about 0.74 per cent. of steel at each edge. It will be noted that this problem assumes the same bending moment as the last, while the eccentricity has been reduced. This, of course, means that the axial force,  $H$ , must be increased in the same ratio, and the necessary increase in the percentage is thus explained.

#### PROBLEMS

43. Read, in *Transactions of American Society of Civil Engineers*, Vol. XLI, the article on safe stresses in steel columns.

44. Deduce a formula for  $M = N C b h^2$  in Case I, by the method employed in Case II.

45. The bending moment in a certain section of a beam is 500,000 lb. in., the resulting stress being applied 4 inches from the middle, the breadth and depth are 12 and 20 inches respectively. If the reinforcement be  $p = p' = .8$  per cent., what values have  $C$ ,  $C'$ ,  $S_c$ , and  $S_t$ ?

46. In the last problem, what will be the stresses if the same axial force be applied 2 inches from the middle?

47. In the same problem, what will be the stresses if the same bending moment be occasioned by an axial force applied 2 inches from the middle?

48. Design a reinforced concrete beam of 1:2:4 concrete and mild steel, the length being 18 feet, the load 500 pounds per linear foot, besides the weight of the beam, and the axial load 2000 pounds, applied 4 inches from the middle of the section.

**Flexure and Axial Tension.** Whether under Case I or Case II, the above discussion applies as well to tension as to compression, when either stress is added to that of bending. In (81) and (82) it is to be noted that both  $C$  and  $C'$  depend upon the sum of the stresses due to direct compression and to flexure. The first fraction in these equations give the compressive stress due to axial forces, and these stresses will simply change sign if the force parallel to the axis be changed. Hence, the same formulas and diagrams apply for axial tension as for axial compression under Case I.

The formula used in finding the value of  $k$  (74) applies when the direction of the thrust is considered. Since  $He = M$ , the sign of  $e$  changes with that of  $H$ , so the formula for  $K$  in the case of axial compression is changed to suit the case of axial tension if the sign of  $e$  in (91) be changed wherever it occurs. The formula then becomes

$$k^3 - 3k^2(h/2 + e) - 12kenph + 6pn(eh^2 - 2u_1^2h) = 0$$

also

$$C = \frac{-2Hk}{bk^2 + 2pbhn(2k - h)}$$

With these formulas problems of this nature may be solved or diagrams similar to Plates IX and X may be readily constructed.

Instances of such a combination of stresses are rather rare in reinforced concrete design, since masonry of any kind is not well adapted to take tension; but in any case there should be no trouble experienced in adapting any formula for a positive thrust to a problem involving thrust in an opposite direction.



## PROBLEM

49. Construct diagrams similar to Plates X and XI for values of  $k$  and  $N'_7$  when axial tension is combined with flexure.

*Columns*

Concrete is widely used for columns, and may or may not be employed with steel in this way. When steel is used in this connection, the concrete is sometimes but a covering or filler for the purpose of adding beauty, symmetry, and fire protection. It is then not essential to the security of the structure although it gives some additional strength and stiffness. This type is not strictly reinforced concrete, and the analysis of stresses in such designs need not be taken up here. The steel in these columns is made up of structural shapes in a variety of designs, and no part of the load is assigned to the concrete. This style of column is effective, and is to be highly commended.<sup>1</sup>

Plain columns will be referred to for the particular purpose of comparing the strength of such with that of columns reinforced in different ways. It may be said that the most economical reinforcement, or means of strengthening, is additional or better cement in the mortar of which the column is composed. Where the space is not too limited, plain concrete is much used for short columns.

**Columns with Longitudinal Reinforcement.** In general, column reinforcement is of two kinds, longitudinal and circumferential. The latter kind is usually in the form of a spiral, either flat or of wire, or made of bands or hoops, and is called "hooped." The intended action of these two varieties of reinforcement is very dissimilar in the two cases. In the former the metal acts in direct compression, and its shortening under the load is the same as that for the concrete, the accompanying stresses depending upon the coefficient of elasticity of the steel and of the concrete. In the hooped columns the metal is used to confine the concrete, which takes all the axial stress, thus preventing disintegration by crushing or by diagonal shear.

Upon the assumption that the load is uniformly distributed over the cross-section of the column, the steel should be sym-

<sup>1</sup> For an example of the use of structural steel with concrete see *Trans. Am. Soc. of C. E.*, 1908, Vol. LX.

metrically distributed over that area. The distance of the metal from the outside would be immaterial, and the reinforcement might even be placed in the middle. However, columns are never exactly straight, and the loads are seldom centrally applied, so the rods are usually not over 2 inches from the outside. Fig. 47 (b) shows bands of wire used to prevent buckling of the rods

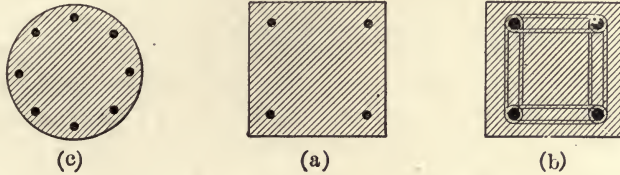

FIG. 47.

under excessive loads, when the concrete takes a continually decreasing proportion of the load. Since the deformation of steel and concrete is the same, the stresses vary with  $E_c$  and  $E_s$ ; the value of  $n$  may change from 12 to 25 during a test of a column and the ratio of stresses changes accordingly.

Let  $A$  = the area of steel in the section

$A_c$  = the total area of the section

$P$  = the total load on the column.

Then 
$$P = C(A_c - A) + S_c A$$

$$= C(A_c - pA_c + npA_c)$$

$$= CA_c [1 + p(n - 1)] \quad (101)$$

Solving, 
$$p = \frac{P - CA_c}{AC_c(n - 1)} \quad (102)$$

also 
$$A_c = \frac{P}{C[1 + p(n - 1)]} \quad (103)$$

The excess of strength of the reinforced over the plain concrete column is

$$A(S_c - C) = pA_c C(n - 1) \quad (104)$$

and the ratio of increase is

$$\frac{pA_c C(n - 1)}{A_c C} = p(n - 1) \quad (105)$$

The ratio of increase in strength is seen to be independent of  $C$ .

These relations are based upon the supposition that the rods and the concrete are firmly connected by the bond, so that they act together. Experiments show that, under ordinary conditions, this assumption is correct, and that the steel will carry the proportion of the working load indicated by the above formulas. Ultimate failure is sometimes caused by the buckling of the reinforcement which causes the outside concrete to

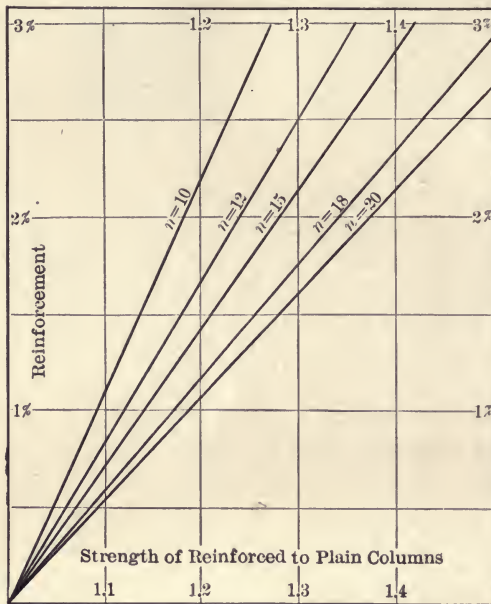

FIG. 48.

scale and the cross-section to be thereby reduced. Hence the steel should not be placed too near the surface and about  $1\frac{1}{2}$  inches of concrete usually covers the rods on the outside.

As an example of the use of these formulas, let it be required to determine the proper size of a square column, reinforced with 2 per cent. of steel, to carry a load of 100,000 pounds with a unit stress of 450 pounds in the concrete. Let  $n = 15$ . In (103)  $A_c = 100,000 \div 450 (1 + 0.02 \times 14) = 174$  square inches, or the column should be 13.2 inches square.

Again, what will be additional strength of the column if the reinforcement be increased to  $2\frac{1}{2}$  per cent.? From (101) the increase in strength changes from  $0.02 \times 14 \times 174 \times 450$  to  $.025 \times 14 \times 174 \times 450$  or 10,960 pounds for each percentage of steel. In the first case the strength of the concrete column has been increased by  $0.02 \times 14$  or 28 per cent., and in the second case by  $0.025 \times 14$  or 35 per cent. by the addition of the steel.

These relations are shown in Fig. 48. The disproportion between the strength of steel and that of concrete is emphasized



more as the latter becomes leaner, or as  $n$  becomes greater. Hence, for the same percentage of steel, the percentage of increase in strength of the reinforced over the plain column is greater with the leaner concrete. Referring to Fig. 48, it is seen that 2 per cent. of steel increases the strength of a plain column 38 per cent. when  $E = 1,500,000$ , but the increase is only 18 per cent. if  $E$  be 3,000,000, or if  $n$  be 10.

As an example of the use of Fig. 48, let the column be  $11 \times 11$  inches, the load 60,000 pounds, and the working strength of the concrete be 400 lb. per sq. in. If  $n$  be 15, what per cent. of steel is needed? The stress per square inch of cross-section is  $60,000 \div 121 = 496$  pounds, while but 400 pounds is to be allowed per square inch of concrete. So the per cent. of increase in strength must be 24, and the diagram shows that 1.7 per cent. of steel is needed.

**Tests of Plain Columns.** The following table is a summary of tests of plain columns taken from Bulletin No. 20, of the University of Illinois Engineering Experiment Station, 1907. These results should be compared with those for compression of cubes given on page 16. These columns were cylindrical, 12 inches in diameter, and 10 feet long. In general, failure took place in the middle half of the length, the exceptions being when local imperfections were apparent.

“In general, two somewhat distinct forms of failure were observed, (a) a failure which may be termed a diagonal shearing failure, and (b) a failure which may be termed simple compression. In the first the fracture was angular in nature, having the appearance of a diagonal shearing failure characteristic of the manner of failure in compression so common in brittle materials. In these failures the columns broke suddenly and without warning, some of them breaking after the machine had been stopped and while no additional load was being applied. A loud report accompanied the failure. The second column failed suddenly and had given so little warning that the instruments had not been removed. In the second form of failure, here called “simple compression,” the column shattered, cracking longitudinally for some distance, the cracks being well distributed over the faces of the column. In some of these, the failure was not noted until the weighed load began to decrease, and the position of the failure was not determined until the machine had produced a further shortening of the column. As will be seen in the table, nearly all the richer mixtures (1-1½-3 and 1-2-4) gave diagonal shearing failures, and the columns made with lean mixtures crushed throughout the whole fracture in what are here termed simple compression failures.

... For both forms of failure, it may be stated in general that the approach of the ultimate strength of the column might have been predicted from the increase in the rate of shortening and from the shape of the load-deformation diagram."<sup>1</sup>

SUMMARY OF TESTS OF PLAIN CONCRETE COLUMNS

Mixture	Age days	Maximum load lbs. per sq. in.	Manner of failure	Initial modulus of elasticity
1-1½-3	66	2120	Diagonal shearing without warning	2,800,000
"	62	2480	" " " "	3,890,000
1-2-4	58	1165	Diagonal shearing	2,230,000
"	69	2000	General crushing	3,350,000
"	65	2210	" "	3,440,000
"	64	1590	" "	3,390,000
"	62	1945 <sup>2</sup>	Diagonal shearing	2,660,000
"	72	1460 <sup>2</sup>	General crushing	3,380,000
"	64	1810	Sudden diagonal shearing	2,830,000
1-3-6	61	955	Slow general crushing	—
"	62	1110	General crushing	—
1-4-8	63	575	Slow general crushing	—
"	63	575	" " "	—
1-2-4	203	1925	General crushing	3,270,000
"	194	1845	" "	3,140,000
"	181	1770	" "	3,600,000
"	187	2680	Sudden diagonal shearing	3,000,000
"	187	2160	Diagonal shearing	3,100,000
"	201	1770	General crushing	2,770,000
1-2-3¼	12 mos.	2650	Diagonal shearing	—
"	16 mos.	2770	General crushing	—

The table shows clearly that the richer mixtures produce columns of much higher strength than do the lean ones. The average strength of the several mixtures is as follows: 1-1½-3 concrete, 2300 lb. per sq. in.; 1-2-4 concrete, 1740 lb. per sq. in.; 1-3-6 concrete, 1030 lb. per sq. in., and 1-4-8 concrete, 575 lb. per sq. in.

**Working Load for Plain Concrete Columns.** The safe-unit load for such columns as recommended by the Joint Committee (see page 152) is 450 lb. per sq. in. on concrete, of which cubes will hold 2000 lb. sq. in. The length of the columns should not exceed 12 diameters, the load should not be eccentric, and

<sup>1</sup> Made of Universal cement. All others made of Chicago A A.

<sup>2</sup> Quotation from above-named bulletin.

the age should be 28 days, otherwise the stated safe load should be modified accordingly.

**Tests of Columns with Longitudinal Reinforcement.** The following table is from Bulletin No. 10, University of Illinois Engineering Experiment Station. The mixture was, in each case, 1-2-3 $\frac{3}{4}$  concrete. The elastic limit of the steel was 39,800 pounds per square inch.

Length feet	Age days	Cross-section inches	Reinforcement		Crushing strength lb. per sq. in.	Modulus of elasticity
			Variety	Per cent.		
12	71	12 × 12	4- $\frac{3}{4}$ in. rods	1.20	1587	2,570,000
12	71	"	{ 4- $\frac{3}{4}$ " "	1.21	1862	2,340,000
			{ 12- $\frac{1}{4}$ " ties			
12	65	"	4- $\frac{3}{4}$ rods	1.21	1850	2,570,000
12	65	"	{ 4- $\frac{3}{4}$ " "	1.21	1936	2,430,000
			{ 12- $\frac{1}{4}$ " ties			
12	69	9 × 9	4- $\frac{5}{8}$ rods	1.52	1577	2,330,000
12	70	"	4- $\frac{5}{8}$ " "	1.52	1600	2,090,000
12	65	"	{ 4- $\frac{5}{8}$ " "	1.50	1280	1,800,000
			{ 12- $\frac{1}{4}$ " ties			
9	66	"	{ 4- $\frac{5}{8}$ " rods	1.48	2335	2,500,000
			{ 9- $\frac{1}{4}$ " ties			
12	63	"	{ 4- $\frac{5}{8}$ " rods	1.50	1367	2,000,000
			{ 12- $\frac{1}{4}$ " ties			
9	59	"	{ 4- $\frac{5}{8}$ " rods	1.49	1607	1,900,000
			{ 9- $\frac{1}{4}$ " ties			
6	67	"	4- $\frac{5}{8}$ rods	1.47	2206	1,900,000
12	69	12 × 12	none	0	1710	3,150,000
12	64	9 × 9	"	0	2004	2,530,000
12	65	12 × 12	"	0	1610	2,500,000
12	61	"	"	0	1709	2,370,000
6	63	"	"	0	1189	2,000,000
6	65	9 × 9	"	0	1079	1,490,000

When the concrete is stressed to the ultimate,  $n$  is probably as much as 18. Using this value in (103), and substituting the average values for the 12 inches × 12 inches - 12 feet columns with 1.21 per cent. reinforcement, gives

$$C(1 + .0121 \times 17) = 1809$$

$$C = 1500 \text{ lb. per sq. in.}$$

The average strength of the plain columns of the same dimensions is 1676 lb. per sq. in. For the 9" × 9"-12' columns the



computed value of  $C$  is 1160, and the table gives 2004 lb. sq. in. for a single test, showing that the assumed value of  $n$  is much too large for agreement. The result corresponds fairly well

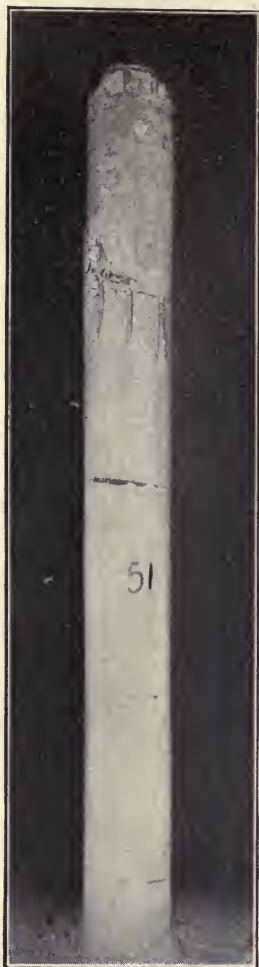

FIG. 49a.



FIG. 49b

with the minimum crushing strength for plain concrete in this table, and also in that on page 16 for 1:2:4 mixture.

Ultimate failure of columns reinforced in this way sometimes takes place through the buckling of the rods between the ties which are usually spaced about a foot apart.

### Working Load for Columns with Longitudinal Reinforcement.

As given on page 152 the recommended unit stress over the cross-section of the column reinforced only with longitudinal rods is  $450(1 + 14 p)$  lb. sq. in. Since the value of  $E_c$  becomes materially less as the unit stresses increase, the factor of safety obtained by dividing the ultimate by the working stress is less than that actually resulting from the use of that working stress. Hence, in case the ultimate strength of a particular mixture is definitely known, the factor, 450, in the above formula may be changed to one found by dividing the known strength by a suitable factor of safety, usually 4.

**Columns with Hooped Reinforcement.** In this construction the office of the reinforcement is only to prevent lateral displacement of the component parts of the concrete while the column is under axial stress. Foundations of sand are known to be stable if the tendency of the grains to move in a plane perpendicular to the direction of the pressure be prevented. The bands, hoops, or spirals do not and cannot take any of the stress in the direction of the axis of the column, but resist the lateral component of the diagonal shear and the swelling shown in Figs. 50 and 51.

The first published reports of experiments on columns of this kind were made in 1902 by Considère, in France.<sup>1</sup> Later, among

<sup>1</sup> *Beton und Eisen*, No. V, 1902. *Génie Civil*, November, 1902.



FIG. 50.

other forms, there were columns tested of octagonal section 1 m. long and 27.5 cm. in diameter at the spiral. The reinforcement consisted of wire wound, with various spacing or pitch, around

longitudinal rods, arranged symmetrically in a circle 15 mm. from the outside. These tests were made at Stuttgart in 1905 and showed decided increase in strength of such columns over those of plain concrete, and the publication of the results created wide interest in this type of construction. Considère concluded that the ultimate load for such columns was  $1.5 A_1 C + S' (A_2 + 24 A_3)$ , in which  $A_1$  is the area of the cross-section inside the spiral, assumed to be  $\frac{2}{3}$  of the whole area,  $C$  is the ultimate stress of the unreinforced concrete,  $S'$  is the elastic limit of the steel,  $A_2$  is the area of the cross-section of the rods, and  $A_3$  is that obtained by dividing the volume of the spiral by the volume of the column inside the spiral. This formula assumes that the spiral is 2.4 times as effective as the longitudinal steel. The above equation may be stated in general form as

$$C_1 = C + pm$$



FIG. 51.

in which  $C_1$  is the unit strength of the column,  $C$  is the unit strength of a plain column of like dimensions,  $p$  is the volume of the spiral divided by that of the column core, and  $m$  is a factor, found by experiment, indicating the effect of the hoops upon the strength of the column.

While the hooping on columns is of great value in making



them capable of large deformation before breaking, it may be easily shown that it can exert very little influence upon the strength of the column until the ultimate strength of the concrete has been reached.

Most substances, when subjected to tension or compression along one axis, will, as a consequence, contract or expand along axes perpendicular to the first. The quotient obtained by dividing this secondary deformation by the first is called Poisson's ratio, and is represented by  $u$ . In the case of concrete under working stresses, this ratio has been found to be from  $\frac{1}{10}$  to  $\frac{1}{8}$ .

Under axial pressure a column tends to take the form shown in (a), Fig. 52. The hoops prevent this lateral deformation and stresses in both steel and concrete result. In every part of the section, as in (c), the axial force,  $P$ , produces forces in all directions in one plane, which may be resolved into  $P'$  and  $P''$  at right angles with each other and in a plane perpendicular to the direction in which  $P$  acts.

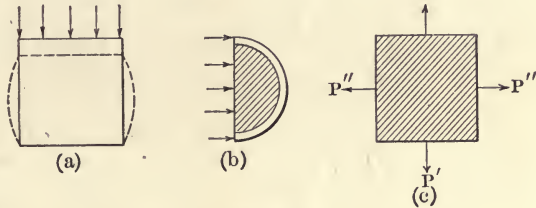

FIG. 52.

It is readily seen that the pair of forces,  $P'$ , produces  $uP'$ , opposing  $P''$ , and so the force exerted by the hoops, necessary to restrain the deformation of the concrete laterally, is not greater than that to restrain it in one direction. If the axial unit stress at a section be  $C$ , the lateral unit stress at a diameter, as shown in (b), is  $uC$ , which produces a lateral deformation perpendicular to the diameter equal to  $uC/E_c$ . This deformation is the same in the hoops as in the concrete, and the stress produced is determined by  $E_s$ . Then, as explained above, this deformation and stress slightly exceed those actually present in the steel, so

$$\frac{S}{E_s} = \frac{S}{nE_c} < \frac{uC}{E_c}$$

and

$$S < unC$$

Letting  $u = \frac{1}{10}$ ,  $C = 600$  lb. sq. in. and  $n = 15$ , this reduces to

$$S < 900 \text{ lb. per sq. in.}$$

Experiments confirm the formula in showing that the stress in the hoops is very small for working loads on the concrete. As  $C$  increases,  $u$  and  $n$  become larger, and, in extreme cases, these may be 2000 lb. per sq. in.,  $\frac{1}{2}$  and 20 respectively. Then  $S$  will be about 8000 lb. per sq. in.

**Tests of Hooped Columns.** Since 1905 many series of tests on this type of column have been made and results published by some of the institutions named in Chapter III. In the main they each confirm the others rather than indicate distinctly new methods or results of investigation. The tests selected for illustration here apply, as many others do not, to columns reinforced only with hoops or spirals without longitudinal rods. The thin strips of metal, used to maintain the even spacing of the hoops, are not capable of taking a material amount of compression, since they are practically on the outside of the column. For a very full description of these tests and a thorough discussion of the results the reader is referred to Bulletin No. 20, University of Illinois Engineering Experiment Station, 1907.

## SUMMARY OF TESTS OF BAND-HOOPED COLUMNS

12 inch diameter columns. Length 10 feet

Reinforcement		Age days	Strength of column lb. per sq. in.		Increase in strength per 1% of reinforcement		Initial coefficient of elasticity
Kind	Per cent.		Rein- forced diameter	Plain (from diagram)	Lb. per sq. in.	Per cent. of increase	
No. 16, 2 in., c to c	1.085	60	2384	1600	725	45	2,670,000
“ “ “	1.085	57	2150	1400	690	49	2,340,000
“ “ “	1.050	59	2182	1450	695	46	2,640,000
No. 12, 2 in., c to c	2.081	63	2860	1600	605	38	2,910,000
“ “ “	2.071	69	2660	1200	705	59	2,000,000
“ “ “	2.120	60	3110	1750	640	37	2,920,000
No. 8, 2 in., c to c	3.22	60	3000	1250	545	44	2,280,000
“ “ “	3.20	66	3715	1650	645	39	2,670,000
“ “ “	3.20	63	2890	1900	310	16	3,160,000
No. 12, 3 in., c to c	1.39	60	2735	1650	780	47	3,000,000
No. 12, 4 in., c to c	1.02	59	2275	1600	660	41	2,670,000
“ “ “	1.02	66	2178	1500	665	44	3,000,000

9 inch diameter columns. Length 10 feet

<sup>1</sup> No. 16, 2 in., c to c	1.35	70	1345	650	515	79	1,080,000
2 " " " "	1.41	56	1260	600	470	78	1,200,000
" " " "	1.47	65	2140	1200	640	53	2,400,000
" " " "	2.73	67	2970	1600	500	31	2,670,000
<sup>2</sup> No. 12, 2 in., c to c	2.94	67	3561	1950	550	28	3,550,000
2 " " " "	2.80	81	3685	2150	550	26	3,910,000

## SUMMARY OF TESTS OF SPIRAL-HOOPEO COLUMNS

Length, 10 feet. Diameter, 12 inches. Pitch, 1 inch

High Carbon Steel

Reinforcement		Age days	Strength of column		Increase in strength per 1% of rein- forcement		Initial coefficient of elasticity
Size of wire	Per cent.		Reinforced	Plain (from diagram)	Lb. per sq. in.	Per cent of increase	
No. 7	0.85	56	2503	1600	1060	66	2,670,000
"	0.85	63	2506	1700	950	56	2,840,000
<sup>3</sup> "	0.82	57	2010	1400	—	—	2,800,000
$\frac{1}{4}$ inch	1.73	57	2718	1400	760	54	2,000,000
"	1.67	60	3800	1900	1140	60	2,720,000
"	1.68	63	3793	1900	1130	59	2,540,000

Mild Steel

No. 7	0.84	60	2080	1350	870	64	2,250,000
"	0.85	64	2203	1500	830	55	2,500,000
"	0.84	61	2220	1450	920	63	2,420,000
$\frac{1}{4}$ inch	1.64	58	2068	1150	560	49	1,920,000
"	1.71	62	3404	1800	940	52	3,280,000
"	—	59	—	—	—	—	—

A 1-2-4 mixture was used in every case.

<sup>1</sup> 1-4-8 mixture. <sup>2</sup> 1-1 $\frac{1}{2}$ -3 mixture. All others were 1-2-4 mixture.<sup>3</sup> This column was loaded with 2000 pounds per sq. in., when the hoops were stripped and it was tested as a plain column with the result given in the table.



The seventh column of the table indicates per cent. of increase in strength of the reinforced over the plain concrete (as determined from the diagram below) for each 1 per cent. of reinforcement, and is found by dividing column six by column five.

The strength of a plain column of the same material is approximately found from the stress-strain diagram plotted for each test of a reinforced column. The diagrams for two of the specimens are shown here. Fig. 53 being for the sixth in the Table for Band-Hooped, and Fig. 54 for the fifth in the last table above. As is common to all such diagrams, there is, within narrow limits, a decided change in the slope of this curve, the first part representing the action of the column before the hoops are brought into tension. The next stage is represented very

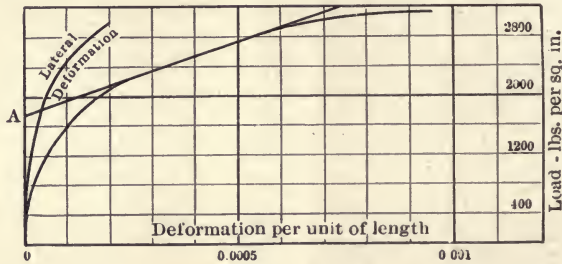

FIG. 53.

nearly by a straight line and continues until nearly the ultimate load is imposed. By producing this line backward to *A*, on an ordinate through the origin, the load is found that is very nearly the ultimate for the plain column as determined by other tests on such columns.

An inspection of these or similar stress-strain diagrams shows nearly a straight line until the unit load imposed is considerably in excess of the working stresses; next, a rapid change in inclination of the curve until the unit deformation is, perhaps, 0.0015, during which time a readjustment of stresses takes place between the concrete and the steel; then, a period during which stresses and deformations change in like ratio, and finally a period of ultimate failure with large deformations and small increase or some decrease in the loads.

The ultimate axial deformations are influenced somewhat by the fact that there is considerable lateral deformation in the

column, especially as the ultimate load is approached. Figs. 49, 50, and 51 show the appearance of specimens of a band-hooped and likewise of a spiral-hooped column failure. The very decided change in the value of the coefficient of elasticity from the initial to the ultimate, of course, is a consequence of the conditions stated. The stress-strain diagrams for all the tests recorded in the tables cannot be reproduced here, but it may be said that the shortening of the column under the load depends upon the amount and type of reinforcement, being more with spirals than with hoops. As compared with the shortening of a plain column, the spiral, for each one per cent. of reinforcement allows about twice the excess of axial deformation, as does the band-hoops, but, at the same

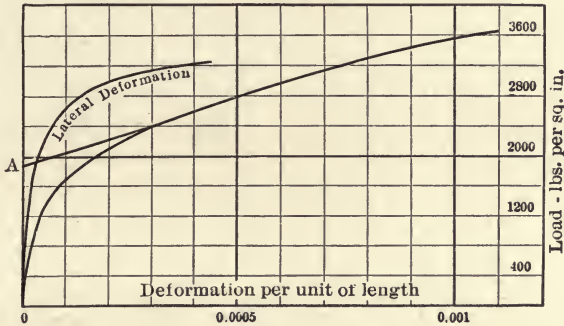

FIG. 54.

time, will sustain materially greater loads, as shown by the tables.

If the coefficients of elasticity of the hooped columns be compared with those for the plain concrete columns in the table on page 106, the rather remarkable fact is apparent that the hooping does not serve to diminish deformation in a column even under working loads. The average value of  $E_c$  from the table for plain columns is 3,090,000 lb. per sq. in. for the 1:2:4 mixture, while for banded reinforcement it is 2,666,000, and for the spiral 2,540,000 lb. per sq. in. There seems to be no known reason for this action of the reinforcement, unless it be that, during fabrication, more perfect compacting of the plain concrete is possible without it. However, the shortening of a column, of such length as is found in engineering practice, is not materially different whether  $E_c$  be 1,500,000 or 3,000,000

lb. sq. in. For example, let the unit stress be 600 lb. sq. in. and the length 25 feet. Then the shortening will be  $300 \times 600 \div 1,500,000$  or  $300 \times 600 \div 3,000,000 = 0.12$  inch or 0.06 inch, according to the value of  $E_c$  used.

During the above tests the hooped columns shortened from  $\frac{3}{4}$  inch to  $1\frac{3}{4}$  inches in the 10 feet of length, while the lateral deflection was apparent even before the maximum loads were imposed. In some cases this lateral deformation was as much as 5 inches, after the period of maximum load had been passed, but while the column was in one piece and still capable of bearing some load. Columns of this kind are actually broken into two pieces with considerable difficulty.

**The Strength Added by Hoops.** Referring to the above tables of tests, it is seen that the gain in strength of the 12-inch banded columns over the plain concrete is 639, or, omitting the 310 as belonging to a column known to be exceptional, 669 lb. sq. in. for each one per cent. of reinforcement. The corresponding increase for the 9-inch columns is 538 lb. per sq. in. The next column of figures shows the per cent. of increase for each one per cent. of reinforcement. The change of mixture to 1-4-8 and 1- $1\frac{1}{2}$ -3 seems to have but little effect upon the strength added to the 9-inch columns by the steel, but is shown distinctly in "per cent. of increase."

The spiral hooping adds more than do the bands to the column strength, the increase being an average of 1008 and 890 lb. sq. in. for the high carbon and mild steel respectively, the next to the last test being omitted as it was known to be not representative. With this large additional strength was a greater ultimate compression, more lateral deflection of the axis of the column, and perhaps more squeezing out of the concrete between the hoops.

The author of the Bulletin concludes that the general formula, given on page 103 may be adapted to use by substituting the following constants. Then for band-hooped columns,

$$C' = 1600 + 65,000 p \quad (106)$$

and for spiral-hooped columns

$$C' = 1600 + 100,000 p \quad (107)$$

giving about an average of results for mild and high carbon



steel. These formulas are only to indicate the ultimate and not the working loads.

**Working Loads for Hooped Columns.** The Joint Committee (see pages 151 and 152) recommend that, when the length does not exceed 12 diameters, the working stress may be  $450 \times 1.20 = 540$  lb. per sq. in. if the plain concrete be able to hold 2000 lb. per sq. in., and, in general, the working stress may be taken as  $1.20 \times 22.50$  per cent. of the ultimate strength of the concrete at the age of 28 days. It will be noted that this is not far from what would result if the ultimate strength by the above formulas be divided by four.

**Columns with Hooped and Longitudinal Reinforcement.** The formula of Considère, given above, page (87), is intended to apply to this type of construction,  $S'A_2$  being the expression for the strength added by the rods. To make his formula conform to the instructions issued by the Minister of Public Works of France, Considère, in 1906, published a modified form of his expression, which is, in pounds per square inch,

$$C_1 = C + 34,000 (p + 2.1 p') \quad (103)$$

in which  $p$  and  $p'$  are proportions of steel found as explained above,  $C_1$  is the unit strength of the reinforced, and  $C$  that for the plain column. If the section be octagonal and the steel not very near the outside, the strength of the area of concrete inside the steel may be multiplied by 1.5 for the total strength of the concrete.

Such formulas have particular reference to the ultimate rather than the working load, although the effect of the rods is felt from the first application of stress. To get the full effect of rods the joints, if any, should be carefully made, either by lapping them so as to secure the proper bond or by butting them closely together at the ends. If the rods be large and correspondingly few in number it is sometimes advisable to provide sleeves to secure the continuity of the steel. If the rods be placed, at least,  $1\frac{1}{2}$  inches inside the surface, they seldom buckle under working loads, and the hooping, no doubt, serves to prevent any such tendency. For this purpose the amount of steel in the bands seldom needs be as much as one per cent.

It seems probable that the best results are obtained when

## CONSIDÈRE'S COLUMNS

No.	Spiral reinforcement		Longitudinal reinforcement		Per cent spiral reinforcement	Per cent longitudinal reinforcement	Per cent total reinforcement	Unit stress at first crack lb. per sq. in.	Ultimate unit stress lb. per sq. in.	Ratio strength of reinforced to plain concrete
	Pitch inches	Diameter inches	No. rods	Diameter inches						
1	—	None	None	None	None	None	None	1892	1892	1.0
2	1.50	$\frac{3}{16}$	4	$\frac{1}{4}$	0.63	0.25	0.88	2262	2262	1.19
3	1.46	$\frac{1}{8}$	4	$\frac{1}{4}$	1.25	0.25	1.50	2290	2532	1.34
4	1.65	$\frac{3}{8}$	4	$\frac{1}{4}$	2.20	0.25	2.45	2418	3414	1.80
5	1.50	$\frac{3}{16}$	8	$\frac{7}{16}$	0.63	1.22	1.85	3186	3215	1.70
6	1.46	$\frac{1}{8}$	8	$\frac{7}{16}$	1.25	1.22	2.47	3272	3271	1.73
7	1.69	$\frac{3}{8}$	8	$\frac{7}{16}$	2.20	1.22	3.42	3442	3997	2.12
8	1.22	$\frac{1}{4}$	4	$\frac{1}{4}$	1.49	0.25	1.74	2788	2845	1.50
9	1.58	$\frac{3}{8}$	4	$\frac{1}{4}$	2.32	0.25	2.57	2418	3001	1.59
10	1.61	$\frac{1}{2}$	4	$\frac{1}{4}$	3.30	0.25	3.55	2560	3641	1.92
11	1.46	$\frac{9}{16}$	4	$\frac{1}{4}$	5.00	0.25	5.25	2247	3499	1.85
12 <sup>1</sup>	1.58	$\frac{1}{4}$	8	$\frac{3}{16}$	1.16	0.25	1.41	2318	2318	1.22
12 <sup>2</sup>	1.58	$\frac{3}{8}$	8	$\frac{1}{4}$	2.32	0.49	2.81	2333	3271	1.73
12 <sup>3</sup>	1.58	$\frac{9}{16}$	8	$\frac{3}{8}$	4.62	1.01	5.63	2617	4295	2.27
13 <sup>1</sup>	3.15	$\frac{1}{4}$	8	$\frac{1}{4}$	0.58	0.49	1.07	2304	2304	1.22
13 <sup>2</sup>	3.15	$\frac{3}{8}$	8	$\frac{3}{8}$	1.18	1.01	2.19	2546	2574	1.36
13 <sup>3</sup>	3.15	$\frac{9}{16}$	8	$\frac{1}{2}$	2.31	1.45	3.76	2646	2830	1.50
14 <sup>1</sup>	4.72	$\frac{1}{4}$	8	$\frac{3}{8}$	0.39	1.01	1.40	2205	2205	1.16
14 <sup>2</sup>	4.72	$\frac{3}{8}$	8	$\frac{1}{2}$	0.78	1.45	2.23	2603	2603	1.37
14 <sup>3</sup>	4.72	$\frac{9}{16}$	8	$\frac{9}{16}$	1.54	1.96	3.50	2944	2944	1.56

the reinforcement is about equally divided between the hooping and the longitudinal rods.

**Tests of Columns with both Longitudinal and Hooped Reinforcement.** The following tests, referred to before on page 109, were made on octagonal columns of 625  $cm^2$  section and one meter long. They were conducted for the owners of the German rights of Considère's patents at a building site, and without effort to exceed the care usually attained in construction. Fig. 55 shows a cross-section of one of these columns. The tests were made under the direction of Professor Bach, of The Royal Technical High School of Stutt-

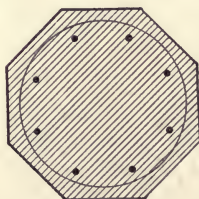

FIG. 55.

gart, and the results were published in 1905. The fact that the length is short in comparison with the diameter makes the results of the tests of less practical value than would have been the case with longer samples.

The diameters of the wire are given in the nearest English equivalent of the metric dimensions and so are not exact. The percentage of steel is computed on the basis of the whole area of the cross-section as the hoops were  $1\frac{1}{2}$  inches inside the surface. By comparing the added strength with the computed addition according to formula (108) it is seen that there is a fair agreement while the pitch remains about  $\frac{1}{2}$ , but the measured strength does not equal the computed in the last six tests. The spiral does not seem to be 2.4 times as effective as the longitudinal reinforcement when the percentage of the former is large as compared with the latter.

It is not possible to determine just what is the effect of the hoops or of the rods, but it seems that the latter may be effectively used to the same extent as the spirals as is shown by Nos. 5, 6, and 7.

The following tests were made at the Watertown Arsenal in 1905, and were published in "Tests of Metals" in 1906. The hoops were riveted, the concrete was 1:2:4 mixture, the diameter was in each case  $10\frac{1}{2}$  inches, and the length was 8 feet. The columns were 5 to 6 months old when the tests were made. The longitudinal reinforcement was made up of  $1 \times 1 \times \frac{1}{8}$  inch angles; the hoops were  $0.12 \times 1.5$  inches.

COLUMNS WITH HOOPS AND LONGITUDINAL ANGLES

Reinforcement		Per cent. hoops	Per cent. angles	Strength lbs. per sq. in.	Increase over plain column	Increase over hooped column	Per cent. of increase per 1 per cent. of	
Number hoops	Number angles						Hoops	Angles
None	None	None	None	1413	—	—	—	—
13	0	1	0	2232	819	—	58	—
13	4	1	1.0	3029	1616	797	58	56
25	0	1.8	0	3428	2015	—	79	—
25	4	1.8	1.0	4189	2776	761	79	54
47	0	3.4	0	5289	3856	—	80	—

It may be said that the longitudinal reinforcement is effective in the early stages of the tests, or within the working loads,



while the hoops increase the ultimate strength. In the table the beneficial effect of decreasing the pitch of the hooping is readily seen. While one per cent. of hooping adds 58 per cent. to the strength, 3.4 per cent. adds 272 per cent., and the latter is 38 per cent. more effective per unit of cross-section. In making these comparisons it should be noted that the strength of the plain concrete column was below normal.

**Working Loads.** If the reinforcing bars be firmly imbedded in the concrete the elastic limit of the steel is a controlling factor in determining the safe strength of the column. If the stress in the metal be taken as  $\frac{1}{4}$  the elastic limit, or about 8000 lb. per sq. in., the stress in the concrete will be this amount divided by  $n$ , or 530 lb. per sq. in., and this may safely be used if  $p$  be as much as one per cent.

The Joint Committee recommends (see page 152) 38 per cent. of the ultimate strength of the plain column, or 600 lb. per sq. in. for good grade of concrete.

**Long Columns.** When the length is not more than about eight or ten times the diameter, the strength of the column differs but little from the cube or the short cylinder, as is apparent from the records of tests given before. Between the limits, length = 10 diameters and length = 15 diameters, the computations and recommended unit stresses may be used as given in this chapter. Beyond the last-named ratio the action of the load is not so nearly that of direct crushing and the effect of the bending moment must be recognized from the first. Concrete, whether plain or reinforced, is not specially adapted to this type of construction, and is not so used to a great extent.

The ordinary formulas for columns of other materials may theoretically be adapted to those of concrete when the constants have been well determined. This question has not been given the attention necessary to a final statement as to the value of  $\phi$  in the formula, but the form of the equation should be

$$\frac{P}{A} = \frac{C}{1 + \phi \frac{l^2}{r^2}}$$

in which  $\phi$  is the constant to be determined for various conditions of reinforcement, mixture, and methods used in fixing the ends, and  $r$  is the radius of gyration. Some tests on long

columns of the "Gray" section have been made at the University of Illinois Engineering Experiment Station which show that a straight line formula may be used. The columns were made of angles and tie plates wound with a wire spiral. The steel was 13 sq. in. in cross-section or 10.8 per cent. of the gross column area. The columns were from 4 ft. 8 in. to 19 ft. 4 in. in length and 16 inches across the section, which included a fire-proofing covering 2 inches thick. The compressive strength of cubes of the concrete was 2150 lb. per sq. in. The ultimate strength of the steel column was

$$P = A \frac{35,000}{1 + \frac{l^2}{12,000r^2}}$$

and for the longest column  $l^2/r^2$  was 59.5.

The ultimate strength of the reinforced column was given by

$$P = A (5100 + 45 l/d)$$

The area of the concrete case was 120 sq. in.

Many of the tests on long columns seem to indicate that the loss of strength with the increase of length is largely due to the fact that the number of weak spots in the column is proportionally increased. Long columns often break near or at the end rather than near the middle.

### PROBLEMS

50. Find the size of a square column to have 2 per cent. of longitudinal reinforcement only, and to sustain a load of 100,000 pounds. Assume 1:2:4 mixture and mild steel.

51. The diameter of a column is 8 inches, and the imposed load is to be 105,000 pounds. What is the required amount of reinforcement in the form of longitudinal bars?

52. A square column 10 by 10 inches carries a load of 125,000. If the reinforcement be  $4\frac{3}{8}$ -inch. round rods, what is the stress in the steel and in the concrete?

53. What should be the diameter of a column, reinforced with 1 per cent. of hooping, safely to carry a load of 90,000 pounds?

54. The load on a column is to be 200,000 pounds. If the diameter be 18 inches, what per cent. of hooped reinforcement is required to keep the stresses within safe limits?

55. If the load be 75,000 pounds, the diameter 7 inches,  $p = 1$  per cent., find the stresses in the concrete and in the steel.

56. Required the area of a column 10 feet long carrying a load of 400 tons, having 3 per cent. of longitudinal and 1 per cent. of hooped reinforcement.

57. In Problem 51 what amount of reinforcement will be sufficient if it be equally divided between hoops and longitudinals?

**Beams Supported in More than Two Places.** Under this head may be included continuous beams, or those supported at various points in the span, and also those supported along lines not parallel to each other, as slabs resting on three or more edges.

**Continuous Beams.** When the bending moments at all points in a continuous beam are known, the beam is designed or investigated by the same formulas as are used for the purpose with simple beams. These moments, in turn, depend upon the moments at the various supports which, for uniform loads, are determined by the application of what is called "the theorem of three moments," as deduced by Clapeyron in 1857. This theorem<sup>1</sup> assumes that the supports are all on the same level, and that the moments of inertia of the cross-sections are uniform throughout all the spans. In reinforced concrete construction the first assumption is usually correct, the second one often is not. The moments at the supports due to concentrated loads may also be found by method of reasoning not very different from that for uniform loads, and it is not necessary to present either method here in great detail.

By means of the theorem of three moments a general formula for the negative bending moments at any support, for equal spans and uniform loads, may be deduced.<sup>2</sup> This formula is

$$M_r = - \frac{\Delta_{r-2} D_{n-r+1} - D_{r-2} \Delta_{n-r}}{2 \Delta_{n-1}} w l^2 \quad (109)$$

in which  $r$  is the number of the support from the left, and  $n$  is the number of spans. Also

$$\Delta_0 = 1, \Delta_1 = 4, D_0 = 0 \text{ and } D_1 = 1.$$

$$\text{In general} \quad \Delta_r = 4 \Delta_{r-1} - \Delta_{r-2}$$

$$\text{and} \quad D_r = \Delta_{r-1} - D_{r-1}.$$

<sup>1</sup> See Merriman's *Mechanics of Materials*, Chap. VIII.

<sup>2</sup> See article by A. R. Crathorne in *Science*, April 29, 1910.



Making these substitutions the following values of  $\Delta$  and  $D$  are found.

$$\begin{array}{cccc} \Delta_0 = 1 & \Delta_3 = 56 & D_0 = 0 & D_3 = 12 \\ \Delta_1 = 4 & \Delta_4 = 209 & D_1 = 1 & D_4 = 44 \\ \Delta_2 = 15 & \Delta_5 = 780 & D_2 = 3 & D_5 = 165 \end{array}$$

Other values may be easily added if required.

As an example, let it be required to find the bending moment at the third support from the left in a continuous beam of five spans. Here  $M_3 = -(\Delta_1 D_3 - D_1 \Delta_2) \div 2 \Delta_4 w l^2 = 3/38 w l^2$ .

The positive moment at  $x$  to the right of a support is  $M' - V'x + \frac{1}{2} w x^2$  where  $M'$  is the moment at the support to the left of the section and  $V'$  is the shear just to the right of the same support. The value of  $V'$  is found from

$$V'l = M'' - M' + \frac{1}{2} w l^2$$

in which  $M''$  is the moment at the support to the right of the given section. The shear at the other end of the panel is always  $w l - V'$ .

The maximum positive moment is at  $x = V' \div w$ , and becomes

$$M = M'_n + V'_n/2 w$$

The subscript indicates the number of the panel considered.

Continuous beams of reinforced concrete are nearly always built with fixed ends and are rigidly attached to the intermediate supports. That the latter fact is not considered in the computations of the moments is a practice on the side of safety. If the beam of four spans be fixed at the ends and supported in uniform spans, with a uniform load on all the spans, the maximum negative bending moment at the supports is

$$M = -\frac{1}{2} w l^2$$

and the maximum positive moments between supports is

$$M = \frac{1}{24} w l^2.$$

If the ends be simply supported, the maximum moments become

$$M = -\frac{3}{8} w l^2.$$

and

$$M = \frac{1^2}{1^2 8^2} w l^2.$$

For either more or fewer spans, generally, the moments will be less than these. It is possible, by omitting the loads on a part of some spans, to slightly increase these moments, but this fact is partly, at least, balanced by the rigidity of the connections between beam and the columns or other beams forming the supports. In practice, moreover, it is impossible to omit all of the load on any panel as the weight of the concrete itself is considerable.

**Working Moments for Continuous Beams.** In view of the above-named considerations it has become the practice to make the maximum moments, both positive and negative,  $\frac{1}{12} w l^2$ , except at the ends of the beam and at the middle of the end panels where the moments are taken as,  $\frac{1}{10} w l^2$ . In these expressions  $w$  is both the live and the dead load per linear foot. If the beam be a slab continuous over several floor beams the moments are uniformly  $\frac{1}{12} w l^2$ . These figures are in almost universal use, both in this country and in Europe, and are believed to represent conservative practice if the concrete be well made and if both that and the steel be erected in a workmanlike manner.

**Slabs Supported on Four Sides.** This question involves two problems, (a) the stresses in the slab itself, and (b) the distribution of the loads carried by the slab upon the supporting beams. Reliable tests and thorough analyses have been made concerning the stresses in slabs of homogeneous material by Bach, Grashof, and others, but they are not, in all respects, applicable to reinforced concrete. There are numerous difficulties in the way of making many tests of full-sized floor slabs of, say, 15 feet square. As a result few such tests have been made in such a way as to be useful as references.

The usual method employed in computing the stresses in a slab, supported or fixed around the edges, and reinforced with rods parallel to the sides, is to, first, find the proportion of the whole load carried by each system of reinforcement, and then consider the slab a simple beam or fixed beam, as the case may be. This method is only approximate, but stresses so computed should be larger than those actually existing.

Let Fig. 56 represent a slab, of length  $l$  and breadth  $b$ , resting upon beams on the four sides. Let the reinforcement consist of rods parallel to  $l$  and to  $b$ , and let the load be uniform over

the area  $bl$ . It is required to find  $w_1$  and  $w_2$ , the parts of the whole unit load,  $w$ , that is carried by the reinforcement parallel to  $xx$  and by that parallel to  $yy$ . The deflections of the strips of unit width at  $a$ , a point on a diagonal, are, of course, the same for  $xx$  as for  $yy$ , and are proportional to the fourth power of the length of the strip. Hence,  $w_1b^4 = w_2l^4$ , and, since  $w_1 + w_2 = w$

$$\frac{w_1}{w - w_1} = \frac{l^4}{b^4}$$

or

$$\frac{w_1}{w} = \frac{l^4}{b^4 + l^4}$$

which represents the proportion of the load carried by the system parallel to the shorter axis. From this formula the following table is easily deduced,

$\frac{l}{b}$	1.0	1.1	1.2	1.3	1.4	1.5	2.0
$\frac{w_1}{w}$	.50	.59	.67	.74	.80	.84	.89

Thus, if a slab be  $10 \times 12$ , the system parallel to the shorter axis carries more than two-thirds of the load. The steel parallel to the longer axis will not be stressed sufficiently to make its use economical if the disproportion in the lengths of the sides be great. For this reason it is common to use the longer system only to provide for shrinkage and expansion stresses if  $l/b$  be more than 1.5, and to provide for the carrying of the entire load on the transverse system.

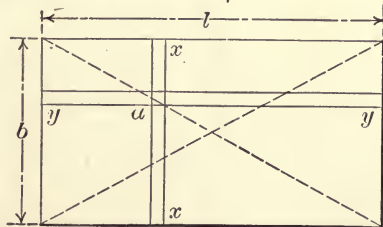

FIG. 56.

Under a uniform load the slab deflects from a plane to a curved surface. The intersection of this surface and a plane perpendicular to the slab is a curve, the equation of which depends upon the amount and distribution of the reinforcement. Were this equation known it would be possible to compute the stress at any point from the deformation, and the reinforcement could be distributed as needed. It is readily seen that, in the beam



of length  $b$  and width  $l$ , the supports parallel to  $b$  diminish the stresses along those sides and, hence, less reinforcement is needed in the strips  $xx$ , that are near the ends than in those near the middle. Even without exact computation some difference in the spacing of the rods may be made, and the saving of steel thus possible is considerable, but the spacing is usually even.

Having determined, from the table, the proportion of the load carried by the transverse reinforcement, the moment is  $\frac{1}{8} w_1 b^2$  if the slab be simply supported. If the slab be continuous the moment will be  $\frac{1}{12} w_1 b^2$  or  $\frac{1}{10} w_1 b^2$ , according to the rules laid down under continuous beams above. The recommendations of the Joint Committee will be found on page 148, and are to be followed in design and investigation. It will be found that panels should be either comparatively long and narrow, so that one system of reinforcement can take all the load, or else square, so that the load may be evenly divided between the two systems and the working strength of steel may be fully developed in both.

**Distribution of Floor Loads to Beams.** If but one system of reinforcement be used, all the load on the slab is considered to be carried to the beams at the ends, and the uncertain part that is carried to the girders supporting the beams is ignored in the computations. The same assumption will be made in case the slab is reinforced in two directions unless it be nearly square. In such cases it is certain that this assumption will not hold good.

Fig. 57 represents a slab, nearly square, resting upon the four surrounding beams. If the slab be reinforced in both directions the load will be carried to the two sets of parallel beams as indicated in the above table, page 125. Of the part of the load that is carried to the beams  $ad$  and  $bc$ , one-half is, evidently, supported by each of these beams if the load be uniform. If the beams  $ab$  and  $dc$ , with the part of the load carried by them, are to be considered quite separately from the other two, the load on beam  $ad$  is represented by  $adfe$ , uniformly distributed along  $ad$ . The effect, however, of the support afforded by beams  $ab$  and  $dc$  is to prevent a uniform distribution of a uniform load. If the relations between the deflection, the bending moment, and the reactions of a beam with a uniform load be considered, it is at once apparent that

the loads are not uniform along the beams. Let a section be passed through  $ef$ , midway between  $ad$  and  $cb$ , cutting the loaded slab in some unknown curve. The longest ordinate to this curve will be at the middle. Let narrow strips,  $xx$ , be passed, intersecting  $ef$  at various points, where the deflections on  $xx$  will be the same as on  $ef$ . The strip,  $xx$ , passing through the middle of  $ef$ , has a greater deflection and, hence, a greater reaction on  $ad$  than have strips nearer  $ab$  and  $dc$ . If the curve of the loaded slab surface were known, the reaction of the strips could be determined with considerable certainty, and even without such knowledge it is clear that the loads are greater toward the middle of the beams.

Fig. 57 shows three assumptions as to the distribution of loads from the slabs. The curve  $ahd$  is a parabola, and  $agd$  a triangle, each having the area  $ae fd$ , which represents the weight carried to the beam  $ad$ , if the thickness

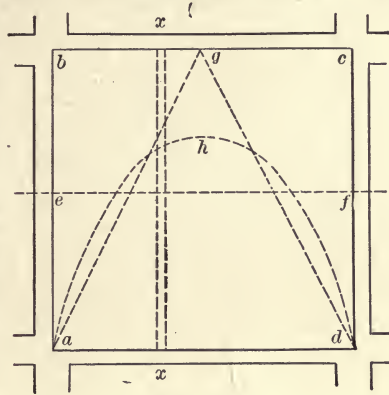

FIG. 57.

of the slab and the load be uniform. The rectangle  $ae fd$  represents a uniform distribution of the load.

If the load be applied as ordinates of the parabola the bending moment at the middle of the longer beam will be

$$M = \frac{wl^4}{b^4 + l^4} \frac{bl}{4} \left( \frac{l}{2} - \frac{3l}{16} \right)$$

$$= \frac{5}{64} w_1 bl^2 \quad (110)$$

or for the shorter beam

$$M = \frac{5}{64} w_2 b^2 l \quad (111)$$

in which  $w$  is the uniform load per unit of area on the slab, and  $w_1$  and  $w_2$  are the parts of that unit load that go to the longer and shorter beams respectively, as given in the table on page 125. If the slab be square,  $w_1$  is  $w/2$  and  $M = \frac{5}{128} wl^3$ .

Applying the loads in the form of a triangle having its apex

at the middle of the beam, the maximum moment will be, for the longer beam

$$M = \frac{wl^4}{b^4 + l^4} \frac{bl}{4} \left( \frac{l}{2} - \frac{l}{6} \right) \\ = \frac{1}{12} w_1 b l^2 \quad (112)$$

and for the shorter beam  $M = \frac{1}{12} w_2 b^2 l$ . (113)

If the slab be square, the moment becomes  $\frac{1}{24} w l^3$ , which is slightly larger than just found for the parabola.

The distribution being considered as uniform, the maximum moment for the beams supporting a square slab is  $\frac{1}{32} w l^3$ , which result is in error to an appreciable extent. These moments are those due to the loads on one panel only.

If the beams supporting the slab be continuous the above moments will be somewhat reduced by the amount of negative moments at each support. These negative moments may be computed by methods given in the reference at the foot of page 122, but this refinement is seldom attempted. The recommendations of the Joint Committee will be found on page 148, and it will be noted that triangular distribution of loads on the beam is the one advocated. This gives the highest factor of safety of the three methods just discussed.

For example, a five-inch slab is to be  $10' \times 12'$ ; the uniform load, including its own weight, is to be 250 pounds per square foot. It is required to find the proper amount of reinforcement in each direction in the slab and the bending moments in the supporting beams. If the slab, loaded with  $w_1$  per square foot, be considered as simply supported on the two longer beams, the bending moment is  $\frac{1}{8} \times .67 \times 250 \times 1200 \times 12 = 301,500$  lb. in. By reference to Plate I,  $N$  is found to be 0.14, and  $p$  must be about .0048. The percentage in the other rods need be only sufficient to support  $w (1.00 - .67) = 82.5$  pounds per square foot, then  $N$  is 0.10 and  $p$  is .002. If the distribution of loads to the beams be according to the ordinates of a triangle, the bending moments at the middle of the longer and shorter beams will be, from (112) and (113),  $\frac{1}{12} \times 250 \times .67 \times 120 \times 144 \times 12 = 2,900,000$  lb. in., and  $\frac{1}{12} \times 250 \times .33 \times 144 \times 100 \times 12 = 1,190,000$  lb. in. In the distribution according to ordinates of a parabola, the two moments are 2,720,000 lb. in., and



1,115,000 lb. in. respectively. The uniform distribution would make the moments 2,225,000 lb. in. and 893,000 lb. in. respectively.

**Girderless Floors.** For several years floors have been built after a design that is simply a thin slab resting upon columns, but the beam and girder construction has been much more common. The pioneer in the field of girderless design has disclaimed any very theoretical analysis of stresses<sup>1</sup> in the slabs, but has built many floors of this kind that are apparently satis-

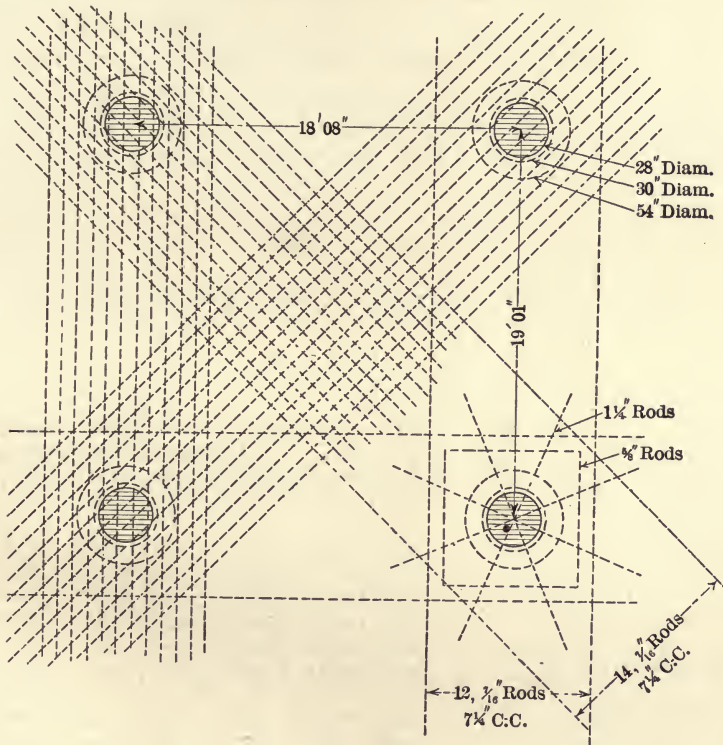

FIG. 58.

factory. It is probable that the lack of certainty as to the stresses resulting from loads on this type of floor has made other designs the more common. Many tests of loaded floors have been made from time to time to determine the deflections

<sup>1</sup> See *Trans. Am. Soc. C. E.*, Vol. LVI, 1906, pp. 297-309.

and whether or not dangerous cracks appear, but the test alluded to below is of special interest and reliability.

The test<sup>1</sup> was made on eight adjacent panels over an area three panels square, one corner panel being omitted. The dimensions of the panels were 18 feet, 8 inches by 19 feet, 1 inch, and the slab was  $9\frac{3}{8}$  inches thick. The concrete was good quality 1-2-4 mixture, and the floor was designed to carry a uniform load of 225 pounds per square foot. During the test the applied load was 350 pounds per square foot. The amount and distribution of the metal reinforcement are shown in Fig. 58. It is seen that the rods are arranged in bands between the columns each way, and also on both diagonals of the panels. In this manner the entire slab is covered, and, around the column heads, the three systems overlap. In addition, eight radial  $1\frac{1}{4}$ -inch rods are inserted over the columns. The summary of observed stresses is given in the following table:

SUMMARY OF STRESSES

	Load, 225 lb. sq. ft.			Load, 350 lb. sq. ft.				
	Live load	Dead load	Total	Live load	Dead load	Total		
<i>Steel overhead</i>								
Diagonal band	{	Maximum	13,800	6900	20,700	24,200	6900	31,100
		Average	11,000	5500	16,500	18,800	5500	24,300
Cross band	{	Maximum	10,000	5000	15,000	18,800	5000	23,800
		Average	9,000	4500	13,500	17,200	4500	21,700
<i>Steel at Center</i>								
Diagonal band	{	Maximum	2,400	1200	3,600	4,800	1200	6,000
		Average	2,000	1000	3,000	4,800	1000	5,800
Cross band	{	Maximum	2,800	1400	4,200	8,000	1400	9,400
		Average	2,500	1300	3,800	6,600	1300	7,900
Outer panels	{	Maximum	4,600	2300	6,900	10,400	2300	12,700
		Average	3,800	1900	5,700	8,000	1900	9,900
<i>Concrete at Capital</i>								
Diagonal direction	{	Maximum	530	265	795	800	265	1,065
		Average	500	250	750	750	250	1,000
Cross direction	{	Maximum	500	250	750	800	250	1,050
		Average	468	234	700	750	234	984

The author of the paper quoted concludes that the test indicates that the moments are much greater at the support than

<sup>1</sup> By Arthur R. Lord, described in *Engineering Record*, January, 1911.

at the center of the span, that the latter stresses are much smaller than usually computed, and that the steel at the center receives its maximum stress when one panel only is loaded. The points of maximum negative moment were found to be nearly over the edges of the capitals of the columns, or about  $0.2 L$  from the middle of the column head,  $L$  being the length of the side of a panel. The points of inflection are about  $0.55 L$  apart, or about  $0.225 L$  from the middle of the projection of the column. The size of the capital of the column is of vital importance and a diameter of less than  $0.2 L$  will cause excessive shearing and flexural stresses.

### PROBLEMS

58. A 4-inch slab is 12 feet by 15 feet, and carries a uniform load of 200 pounds per square foot. Find the reinforcement necessary in the slab in both directions, and also find the bending moment in the supporting beams.

59. Deduce the positive and negative bending moments in a continuous beam of four equal spans if the loads be distributed as the ordinates of a triangle.

60. Read the article by Mr. P. E. Stevens, *Trans. Am. Soc. C. E.*, Vol. LX, 1908, on moments in continuous beams of non-uniform moments of inertia.

61. A square slab is to support a load of 175 pounds per square foot of area. If the span in each direction be 18 feet, and the whole amount of reinforcement be one per cent., what should be the thickness of the slab from top to bottom?

62. What uniform load per square foot can be safely carried by a square slab 15 feet on a side, if the depth be 4 inches and the reinforcement be 0.8 per cent.?

63. What should be the dimensions of the supporting beams in the last two problems if the reinforcement be 1 per cent. and the depth equal to two times the breadth?



## CHAPTER V

### ELEMENTARY DESIGN

**Economical Proportions of Beams.** As reinforced concrete beams are composed of material of different cost, and as the breadth and depth are involved to different extents in making up the strength, the cost of beams of the same strength may vary considerably with different designs.

Let  $q = \frac{\text{value of steel per unit of volume}}{\text{value of concrete per unit of volume}}$

$v =$  value of steel per unit of volume

$v' =$  value of concrete per unit of volume

$V =$  value of the beam per unit of length

Then  $V = b d v' + A v$

(a) *When the breadth is constant*, a certain breadth is required to securely bond the reinforcement. From (15), (7) and (8)

$$V = \sqrt{\frac{6(r+n)^2 b M}{n C (3r+2n)}} v' + \frac{n}{2r(r+n)} \sqrt{\frac{6(r+n)^2 b M}{n C (3r+2n)}} v \quad (114)$$

$$= \left( \frac{r+n}{\sqrt{3r+2n}} + \frac{n}{2r\sqrt{3r+2n}} q \right) \sqrt{\frac{6 b M}{n C}} v'$$

$$\frac{dV}{dr} = \frac{3r+n}{(3r+2n)^{\frac{3}{2}}} - n q \frac{9r+4n}{2r^2(3r+2n)^{\frac{3}{2}}}$$

Putting this equal to zero and simplifying,

$$r^3 + \frac{n}{3} r^2 - \frac{3nq}{2} r - \frac{2n^2q}{3} = 0$$

Dividing by  $n^3$

$$\frac{r^3}{n^3} + \frac{r^2}{3n^2} - \frac{3q}{2n} \cdot \frac{r}{n} - \frac{2q}{3n} = 0 \quad (115)$$

This equation is plotted in Plate XII with  $r/n$  as ordinates, and  $q/n$  as abscissas. The solution gives approximately

$$r = 1.246 \sqrt{nq} \quad (116)$$

This is the value of  $r$  necessary to make  $V$  in equation (114) a minimum. When  $r$  is known,  $p$  and  $d$  are readily found from Plate I.

(b) *When the Depth is Constant.* From formula (15) and (7) a value of  $V$  is found which contains  $d$  instead of  $b$  as above.

$$V = \frac{6 Mv'}{Cdn} \left( \frac{(r+n)^2}{3r+2n} + \frac{(n+r)ng}{2r(3r+2n)} \right) \quad (117)$$

$$\frac{dV}{dr} = \frac{6 Mv'}{Cdn} \left( \frac{2(r+n)(3r+2n) - 3(r+n)^2}{(3r+2n)^2} + \right.$$

$$\left. \frac{qnr(3r+2n) - 2ng(r+n)(3r+n)}{2r^2(3r+2n)^2} \right)$$

Putting this equal to zero and reducing gives

$$r^4 + \frac{4}{3}nr^3 + \left( \frac{n^2}{3} - \frac{qn}{2} \right) r^2 - n^2qr - \frac{1}{3}n^3q = 0$$

Dividing by  $n^4$  (118)

$$\left( \frac{r}{n} \right)^4 + \frac{4}{3} \left( \frac{r}{n} \right)^3 + \left( \frac{1}{3} - \frac{q}{2n} \right) \frac{r^2}{n^2} - \frac{q}{n} \frac{r}{n} - \frac{q}{3n} = 0$$

In Plate XII the curve representing this equation is marked "depth constant." For values of  $q$  and  $n$  in common use, the curve is approximately given by

$$r = .8 \sqrt{ng} \quad (119)$$

From this curve, and approximately from (118), the value of  $r$  that makes  $V$  in (117) a minimum is found. Then the beam may be designed from Plate I. Since the head room is often fixed, it is a common problem to design beams with a given depth.

(c) *When the Area of the Cross-section is Constant.* It may happen that the area, as determined by (a) or (b), will not be sufficiently great to insure the necessary shearing strength which is the unit shearing strength multiplied by  $bd$ . For any given problem  $bd$  is, then, a constant which is known and which may be substituted in (16), giving an equation with  $N_1$  and  $d$  as variables. Plate I shows that the percentage of steel decreases with  $N_1$ , so  $d$  should be made large for minimum cost. If either the breadth or the depth be otherwise limited, the necessary

area of cross-section must be provided for by a variation in the other dimension.

The cross-section is, however, seldom fixed by the shearing stresses except near the end of the beam.

(d) *When the Ratio of Breadth to Depth is Fixed.* This condition is sometimes imposed to preserve symmetry and for other reasons. From (15) there may be deduced

$$b^3 d^3 = \frac{b}{d} \left( \frac{6 (r + n)^2 M}{Cn (3r + 2n)} \right)^2$$

and

$$V = \left( \frac{b \cdot 36 M^2}{d \cdot C^2 n^2} \right)^{\frac{1}{3}} v \left( \frac{(r + n)^{\frac{4}{3}}}{(3r + 2n)^{\frac{4}{3}}} + \frac{qn (r + n)^{\frac{4}{3}}}{2r (r + n) (3r + 2n)^{\frac{4}{3}}} \right) \quad (120)$$

By putting the first derivative equal to zero there results

$$\frac{r^4}{n^4} + \frac{4r^3}{3n^3} + \frac{1r^2}{3n^2} - \frac{qr^2}{nn^2} - \frac{19qr}{12nn} - \frac{1q}{2n} = 0 \quad (121)$$

This curve is platted on Plate XII, and from it the value of  $r$  is found that will make the cost a minimum. The value of  $r$  is also given approximately by the equation

$$r = 1.05\sqrt{nq} \quad (122)$$

Of the three curves thus far platted on Plate XII that representing a constant breadth is seen to show the most rapid change in  $r$  for a given change in  $q$ .

(e) *When the Breadth is Constant and the Stress is Ultimate.* Using the parabolic relation, formula (38) may be changed to

$$bd = \left( \frac{3Mb}{Cn} \right)^{\frac{1}{2}} \frac{r + 2n}{(4r + 5n)^{\frac{1}{2}}}$$

and

$$V = \left( \frac{3Mb}{Cn} \right)^{\frac{1}{2}} v' \left( \frac{r + 2n}{(4r + 5n)^{\frac{1}{2}}} + \frac{4nq}{3r(4r + 5n)^{\frac{1}{2}}} \right) \quad (123)$$

Then the first derivative of  $V$  with respect to  $r$  equated to zero gives

$$\frac{r^3}{n^3} + \frac{1r^2}{2n^2} - 4\frac{qr}{nn} - \frac{10q}{3n} = 0 \quad (124)$$

A part of this curve is shown in Plate XI and may be extended by the approximate value of

$$r = 2.07\sqrt{nq} \quad (125)$$

but  $r$  is seldom more than  $4n$ .



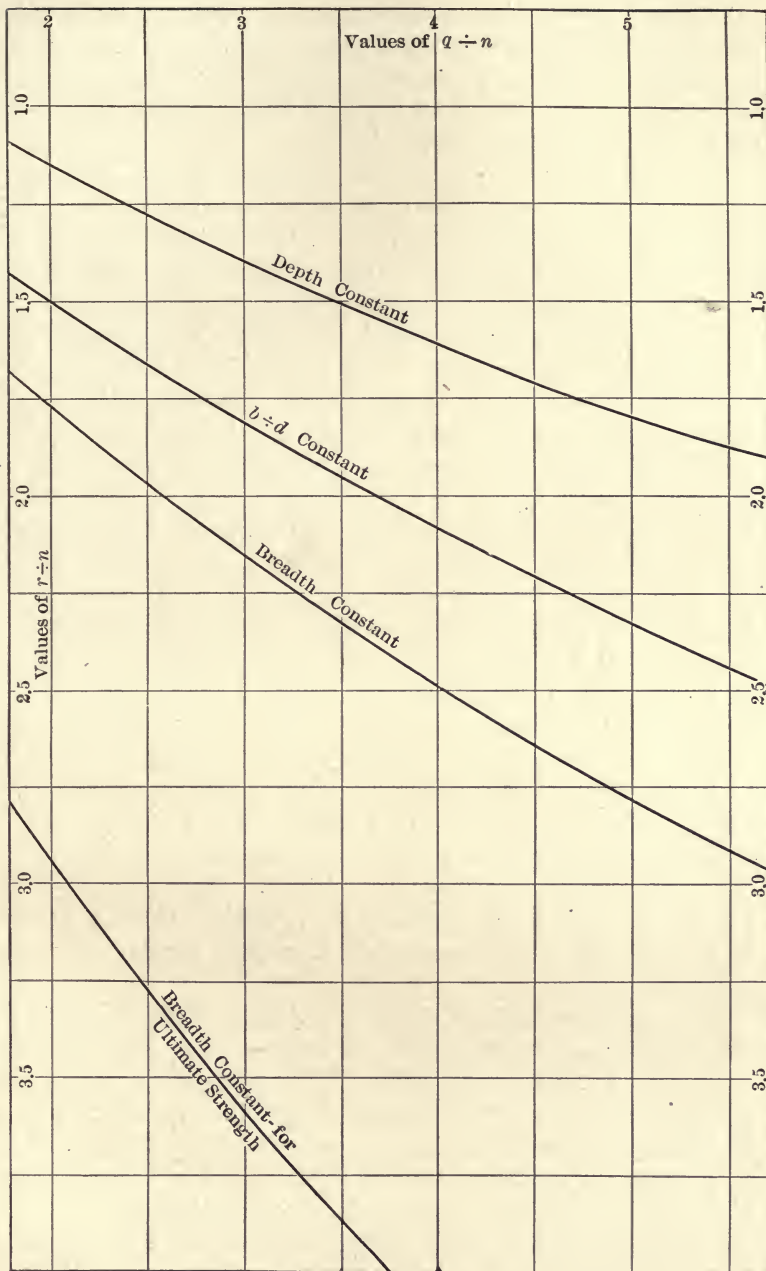

PLATE XII.

The above discussion involves but few phases of the subject of economic design and is given more to indicate methods than to designate results. The analysis may be extended to include the weight of the beam itself but it is usual to allow for a dead load of about one-half the line load.

In a T-beam there are four dimensions and the amount of steel to be determined and, as a result, formulas become unwieldy unless some assumptions are made. If the flange be designed separately to carry the load between beams, the design of the T-beam will be that of the web and the flange remains constant.

For example, let it be required to design a rectangular beam 15 feet long to have a safe bending moment of 500,000 lb. in. Let the price of the steel be  $3\frac{1}{2}$  cents per pound and that of the concrete \$8 per cubic yard, and let the breadth be fixed at 15 inches. Plate XIII gives, for these prices, 58 for the value of  $q$ . Or, if  $n$  be 15,  $q/n = 3.87$ . With this value of  $q/n$ , Plate XII gives 2.44 for  $r/n$  and  $r = 36.6$ , and Plate I, in turn, gives  $N_1 = .132$  and  $p = .4$  per cent. of reinforcement. Then,  $132 \times 600 \times 15 \times d^2 = 500,000$  and  $d = 20.5$  inches. The cost of the beams will be  $15 \times 20.5 \times 15 \div 3888 \times 8 = \$9.49$  for the concrete and  $9.47 \times .004 \times 58 = \$2.20$  for the steel, or \$11.69 total. This does not include the inch and a half of depth below the reinforcement as this is constant whatever the design may be.

If the depth be taken as 19 inches,  $N_1 = 500,000 \div (15 \times 19^2 \times 600) = .154$ ,  $r = 28$  and  $p = .0062$ . Then the price will be, for the beam,  $15 \times 19 \times 15 \div 3888 \times 8 (1 + .0062 \times 58) = \$11.95$ . If the depth be assumed as 21 inches  $N_1 = 500,000 \div (15 \times 21^2 \times 600) = .126$  and  $p = .00355$ . Then the cost of the beam is  $15 \times 21 \times 15 \div 3888 \times 8(1 + .00355 \times 58) = \$11.76$ . Both these prices are seen to be but slightly greater than that deduced by (a).

As an example under (b) let it be necessary to fix the depth in the above beam at 18 inches. It is required to find the most economical breadth. From Plate XII  $r$  is found to be 27.5 and Plate I gives  $.156 \times 600 \times 324 b = 500,000$ , from which  $b = 16.5$  inches and  $p$  is .0065. The beam will cost  $8 \times 16.5 \times 18 \times 15 \div 3888 (1 + .0065 \times 58) = \$12.61$ . For  $b = 15$  inches the cost is \$12.67 and for  $b = 18$  this is increased to \$12.95.

The shear in the above examples is  $\frac{1}{2} W = 11,111$  pounds and for  $b = 15$  and  $d = 20$ ,  $v$  is 37 pounds per square inch. This is

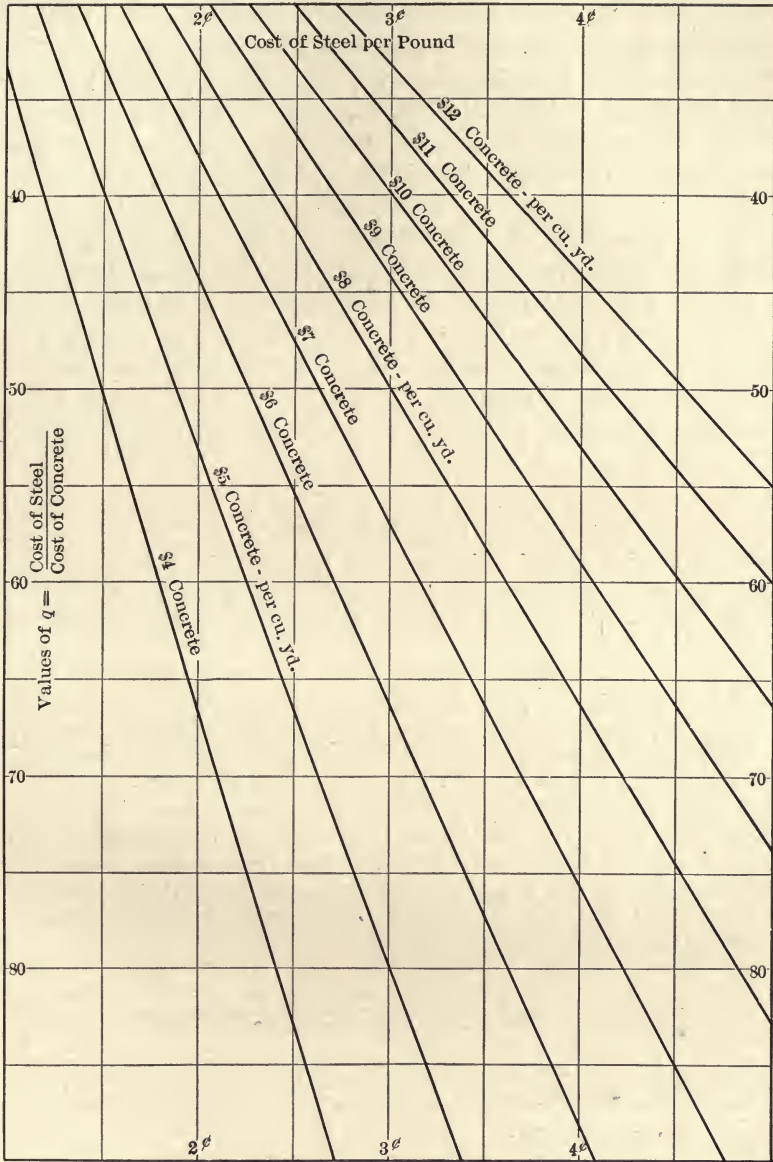

PLATE XIII.



not excessive even if none of the rods be bent up as they nearly always are. Here the shear is not a controlling factor in the design.

As an example of design when  $d/b$  is fixed let this ratio be 2.5, with the length of beam, the bending moment, and the prices as before. From Plate XII  $r$  is found to be 30.8. Plate I gives  $N_1$  as .146 and  $p$  as .00532. Then  $.146 \times 600 \times 6.25b^3 = 500,000$ , and  $b = 9.7$  inches and  $d = 24.3$  inches. The cost of this beam is  $9.7 \times 24.3 \times 15 \times 8 \div 3888 (1 + .00532 \times 58) = \$9.52$ . When  $b$  is 9 inches  $N_1$  is .183 and  $p$  is .0107 and the cost becomes  $9 \times 22.5 \times 15 \times 8 \div 3888 (1 + .0107 \times 58) = \$11.20$ . If  $b$  were assumed to be 11 inches  $N_1$  would be .091 and  $p$  would be .0016. Then the value would be  $11 \times 27.5 \times 15 \times 8 \div 3888 (1 + 58 \times .0016) = \$10.20$ .

If  $d/b$  be assumed as 20.5/15 the deduced value of the width will be 15 inches as in the example under (a).

#### PROBLEMS

64. If the breadth of a beam be 12 inches,  $C$  be 500 lb. sq. in., steel be 3 cents per pound, and concrete \$6 per cubic yard, what will be the least cost of a beam to safely withstand a bending moment of 400,000 lb. in.?

65. Deduce formulas for economic dimensions of beams, taking into account the weight of the beam itself.

66. A beam was designed to carry a load causing a bending moment of 360,000 pounds inches,  $C$  was 500 lb. sq. in.,  $b$  was 10 inches, and  $d$  was 22 inches. If the cost of steel were 2½ cents per pound, what was the cost of the concrete, if the design were economical and the depth were fixed? What when the breadth and when  $b/d$  were fixed?

67. A beam is 12 inches by 24 inches and 16 feet span. With  $b/d$  fixed,  $C = 500$  lb. sq. in., steel at 3 cents per pound, and concrete at \$7 per cubic yard, what percentage of steel can be used with economy, and what will be the bending moment?

#### REPORT OF THE JOINT COMMITTEE

At the annual convention of the American Society of Civil Engineers held at Asheville, N. C., June 11, 1903, the following resolution was adopted:

It is the sense of this meeting that a special committee be appointed to take up the question of concrete and steel concrete, and that such committee cooperate with the American Society for Testing Materials

and the American Railway Engineering and Maintenance of Way Association.

Following the adoption of this resolution, a special committee on concrete and steel concrete was appointed by the Board of Direction on May 31, 1904. At the annual meeting, held January 18, 1905, the title of this special committee was, at the request of the committee, changed to "Special Committee on Concrete and Reinforced Concrete."

At the annual meeting of the American Society for Testing Materials held July 1, 1903, at the Delaware Water Gap, the following resolution was unanimously adopted:

That the Executive Committee be requested to consider the desirability of appointing a committee on "Reinforced Concrete," with a view of cooperating with the committees of other societies in the study of the subject.

At the meeting of the Executive Committee of this Society, held December 5, 1903, a special committee on "Reinforced Concrete" was appointed.

The American Railway Engineering and Maintenance of Way Association appointed a Committee on Masonry on July 20, 1899, with instructions as a part of its duties to prepare specifications for concrete masonry. A preliminary set of specifications for Portland cement concrete was reported to and adopted by the Association on March 19, 1903. At the meeting held in Chicago on March 17, 1904, the Committee on Masonry was authorized to cooperate with the special committee on Concrete and Reinforced Concrete of the American Society of Civil Engineers, and following this action a special sub-committee was appointed.

At a meeting of the several special committees representing the above mentioned Societies, and also a committee appointed by the Association of American Portland Cement Manufacturers, held at Atlantic City, N. J., June 17, 1904, arrangements were completed for collaborating the work of these several committees through the formation of the joint committee on Concrete and Reinforced Concrete.

Some of the specifications recommended by this joint committee have been quoted in Chapter II. The following quotations are inserted here to furnish a guide for class-room design

and also because they represent standard practice among American engineers.

#### PREPARATION AND PLACING OF MORTAR AND CONCRETE

1. **Proportions.** The materials to be used in concrete should be carefully selected, of uniform quality, and proportioned with a view to securing as nearly as possible a maximum density.

(a) *Unit of Measure.* — The unit of measure should be the barrel, which should be taken as containing 3.8 cubic feet. Four bags containing 94 pounds of cement each should be considered the equivalent of one barrel. Fine and coarse aggregate should be measured separately as loosely thrown into the measuring receptacle.

(b) *Relation of Fine and Coarse Aggregate.* — The fine and coarse aggregate should be used in such relative proportions as will insure maximum density. In unimportant work it is sufficient to do this by individual judgment, using correspondingly higher proportions of cement; for important work these proportions should be carefully determined by density experiments and the sizing of the fine and coarse aggregates should be uniformly maintained or the proportions changed to meet the varying sizes.

(c) *Relation of Cement and Aggregates.* — For reinforced concrete construction a density proportion based on 1:6 should generally be used, *i.e.*, one part of cement to a total of six parts of fine and coarse aggregates measured separately.

In columns richer mixtures are often required, while for massive masonry or rubble concrete a leaner mixture of 1:9 or even 1:12 may be used. These proportions should be determined by the strength or wearing qualities required in the construction at the critical period of its use. Experienced judgment based on individual observation and tests of similar conditions in similar localities is the best guide as to the proper proportions for any particular case.

2. **Mixing.** The ingredients of concrete should be thoroughly mixed to the desired consistency, and the mixing should continue until the cement is uniformly distributed and the mass is uniform in color and homogeneous, since maximum density and therefore greatest strength of a given mixture depend largely on thorough and complete mixing.



(a) *Measuring Ingredients.* — Methods of measurements of the proportions of the various ingredients, including the water, should be used, which will secure separate uniform measurements at all times.

(b) *Machine Mixing.* — When the conditions will permit, a machine mixer of a type which insures the uniform proportioning of the materials throughout the mass should be used, since a more thorough and uniform consistency can be thus obtained.

(c) *Hand Mixing.* — When it is necessary to mix by hand, the mixing should be on a water-tight platform and especial precautions should be taken to turn the materials until they are homogeneous in appearance and color.

(d) *Consistency.* — The materials should be mixed wet enough to produce a concrete of such a consistency as will flow into the forms and about the metal reinforcement, and which, at the same time, can be conveyed from the mixer to the forms without separation of the coarse aggregate from the mortar.

(e) *Retempering.* — Retempering mortar or concrete, *i.e.*, remixing with water after it has partially set, should not be permitted.

**3. Placing of Concrete.** (a) *Methods.* — Concrete after the addition of water to the mix should be handled rapidly, and in as small masses as is practicable, from the place of mixing to the place of final deposit, and under no circumstances should concrete be used that has partially set before final placing. A slow-setting cement should be used when a long time is likely to occur between mixing and final placing.

The concrete should be deposited in such a manner as will permit the most thorough compacting, such as can be obtained by working with a straight shovel or slicing tool kept moving up and down until all the ingredients have settled in their proper place by gravity and the surplus water has been forced to the surface.

In depositing the concrete under water, special care should be exercised to prevent the cement from being floated away, and to prevent the formation of laitance, which hardens very slowly and forms a poor surface on which to deposit fresh concrete. Laitance is formed in both still and running water, and should be removed before placing fresh concrete.

Before placing the concrete, care should be taken to see that

the forms are substantial and thoroughly wetted and the space to be occupied by the concrete is free from débris. When the placing of the concrete is suspended, all necessary grooves for joining future work should be made before the concrete has had time to set.

When work is resumed, concrete previously placed should be roughened, thoroughly cleansed of foreign material and laitance, drenched and slushed with a mortar consisting of one part Portland cement and not more than two parts fine aggregate.

The faces of concrete exposed to premature drying should be kept wet for a period of at least seven days.

(b) *Freezing Weather.* — Concrete for reinforced structures should not be mixed or deposited at a freezing temperature, unless special precautions are taken to avoid the use of materials containing frost or covered with ice crystals, and to provide means to prevent the concrete from freezing after being placed in position and until it has thoroughly hardened.

(c) *Rubble Concrete.* — Where the concrete is to be deposited in massive work, its value may be improved and its cost materially reduced through the use of clean stones thoroughly embedded in the concrete as near together as is possible and still entirely surrounded by concrete.

4. **Forms.** Forms should be substantial and unyielding, so that the concrete shall conform to the designed dimensions and contours, and should be tight to prevent the leakage of mortar.

The time for removal of forms is one of the most important steps in the erection of a structure of concrete or reinforced concrete. Care should be taken to inspect the concrete and ascertain its hardness before removing the forms.

So many conditions affect the hardening of concrete that the proper time for the removal of the forms should be decided by some competent and responsible person, especially where the atmospheric conditions are unfavorable.

#### DETAILS OF CONSTRUCTION

1. **Joints.** (a) *Reinforcement.* — Wherever in tension reinforcement it is necessary to splice the reinforcing bars, the length of lap shall be determined on the basis of the safe bond stress and the stress in the bar at the point of splice; or a connection shall be made between the bars of sufficient strength to

carry the stress. Splices at points of maximum stress should be avoided. In columns large bars should be properly butted and spliced; small bars may be treated as indicated for tension reinforcement or their stress may be taken off by being imbedded in large masses of concrete. At foundations, bearing plates should be provided for large bars or structural forms.

(b) *Concrete*. — For concrete construction it is desirable to cast the entire structure at one operation, but as this is not always possible, especially in large structures, it is necessary to stop the work at some convenient point. This point should be selected so that the resulting joint may have the least possible effect on the strength of the structure. It is therefore recommended that the joint in columns be made flush with the lower side of the girders; that the joints in girders be at a point midway between supports, but should a beam intersect a girder at this point, the joint should be offset a distance equal to twice the width of the beam; that the joints in the members of a floor system should in general be made at or near the center of the span.

Joints in columns should be perpendicular to the axis of the column, and in girders, beams, and floor slabs perpendicular to the plane of their surfaces.

2. **Shrinkage.** Girders should never be constructed over freshly formed columns without permitting a period of at least two hours to elapse, thus providing for settlement or shrinkage in the columns. Before resuming work, the top of the column should be thoroughly cleansed of foreign matter and laitance. If the concrete in the column has become hard, the top should also be drenched and slushed with a mortar consisting of one part Portland cement and not more than two parts fine aggregate before placing additional concrete.

3. **Temperature Changes.** Concrete is sensitive to temperature changes, and it is necessary to take this fact into account in designing and erecting concrete structures. In some positions the concrete is subjected to a much greater fluctuation in temperature than in others, and in such cases joints are necessary. The frequency of these joints will depend, first upon the range of temperature to which concrete will be subjected; second, upon the quantity and position of the reinforcement. These points should be determined and provided for in the



design. In massive work, such as retaining walls, abutments, etc., built without reinforcement, joints should be provided, approximately, every 50 ft. throughout the length of the structure. To provide against the structures being thrown out of line by unequal settlement, each section of the wall may be tongued and grooved into the adjoining section. To provide against unsightly cracks, due to unequal settlement, a joint should be made at all sharp angles.

4. **Fire-proofing.** The actual fire tests of concrete and reinforced concrete have been limited, but experience, together with the results of tests so far made, indicate that concrete may be safely used for fire-proofing purposes. Concrete itself is incombustible and reasonably proof against fire when composed of a siliceous sand and a hard coarse aggregate such as igneous rock.

For a fire-proof covering these same materials may be used or clean hard burned cinders may be substituted for the coarse aggregate.

The low rate of heat conductivity of concrete is one reason for its value for fire-proofing. The dehydration of the water of crystallization of concrete probably begins at about 500° F. and is completed at about 900° F., but experience indicates that the volatilization of the water absorbs heat from the surrounding mass, which, together with the resistance of the air cells, tends to increase the heat resistance of the concrete, so that the process of dehydration is very much retarded. The concrete that is actually affected by fire remains in position and affords protection to the concrete beneath it.

It is recommended that in monolithic concrete columns, the concrete to a depth of one and one-half inches be considered as protective covering and not included in the effective section.

The thickness of the protective coating required depends upon the probable duration of a fire which is likely to occur in the structure and should be based on the rate of heat conductivity. The question of the conductivity of concrete is one which requires further study and investigation before a definite rate for different classes of concrete can be fully established. However, for ordinary conditions it is recommended that the metal in girders and columns be protected by a minimum of two inches of concrete; that the metal in beams be protected by a minimum

of one and one-half inches of concrete, and that the metal in floor slabs be protected by a minimum of one inch of concrete.

It is recommended that the corners of columns, girders, and beams be beveled or rounded, as a sharp corner is more seriously affected by fire than a round one.

**5. Waterproofing.** Many expedients have been used to render concrete impervious to water under normal conditions, and also under pressure conditions that exist in reservoirs, dams, and conduits of various kinds. Experience shows, however, that where mortar or concrete is proportioned to obtain the greatest practicable density and is mixed to a rather wet consistency, the resulting mortar or concrete is impervious under ordinary conditions. A concrete of dry consistency is more or less pervious to water, and compounds of various kinds have been mixed with the concrete or applied as a wash to the surface for the purpose of making it water-tight. Many of these compounds are of but temporary value and in time lose their power of imparting impermeability to concrete.

In the case of subways, long retaining walls, and reservoirs, leakage cracks may be prevented by horizontal and vertical reinforcement properly proportioned and located, provided the concrete itself is impervious.

Such reinforcement distributes the stretch due to contraction or settlement so that the cracks are too minute to permit leakage, or are soon closed by infiltration of silt.

Asphaltic or coal-tar preparations, applied either as a mastic or as a coating on felt or cloth fabric, are used for waterproofing, and should be proof against injury by liquids or gases.

**6. Surface Finish.** Concrete is a material of an individual type, and should not be used in imitation of other structural materials. One of the important problems connected with the use of concrete is the character of the finish of exposed surfaces. The finish of the surface should be determined before the concrete is placed, and the work conducted so as to make possible the finish desired. For many forms of construction the natural surface of the concrete is unobjectionable, but frequently the marks of the boards and the flat dead surface are displeasing, and make some special treatment desirable. A treatment of the surface which removes the film of mortar and brings the coarser particles of the concrete into relief is frequently used to

remove the form markings, break the monotonous appearance of the surface, and make it more pleasing. Plastering of surfaces should be avoided, for the other methods of treatment are more reliable and usually much more satisfactory. Plastering, even if carefully applied, is likely to peel off under the action of frost or temperature changes.

## DESIGN

1. **Massive Concrete.** In the design of massive concrete or plain concrete, no account should be taken of the tensile strength of the material, and sections should usually be so proportioned as to avoid tensile stresses. This will generally be accomplished, in the case of rectangular shapes, if the line of pressure is kept within the middle third of the section, but in very large structures, such as high masonry dams, a more exact analysis may be required. Structures of massive concrete are able to resist unbalanced lateral forces by reason of their weight, hence the element of weight rather than strength often determines the design. A relatively cheap and weak concrete will therefore often be suitable for massive concrete structures. Owing to its low extensibility, the contraction due to hardening and to temperature changes requires special consideration, and, except in the case of very massive walls, such as dams, it is desirable to provide joints at intervals to localize the effect of such contraction. The spacing of such joints will depend upon the form and dimensions of the structure and its degree of exposure.

Massive concrete is also a suitable material for arches of moderate span where the conditions as to foundations are favorable.

2. **Reinforced Concrete.** By the use of metal reinforcement to resist the principal tensile stresses, the concrete becomes available for general use in a great variety of structures and structural forms. This combination of concrete and steel is particularly advantageous in beams where both compression and tension exist; it is also advantageous in the column, where the main stresses are compressive, but where cross-bending may exist. The theory of design will therefore relate mainly to the analysis of beams and columns.

3. **General Assumptions.** (a) *Loads.* — The loads or forces to be resisted consist of:



1. *The dead load*, which includes the weight of the structure and fixed loads and forces.

2. *The live load* or the loads and forces which are variable. The dynamic effect of the live load will often require consideration. Any allowance for the dynamic effect is preferably taken into account by adding the desired amount to the live load or to the live load stresses. The working stresses hereinafter recommended are intended to apply to the equivalent static stresses so determined.

In the case of high buildings the live load on columns may be reduced in accordance with the usual practice.

(b) *Lengths of Beams and Columns*. — The span length for beams and slabs shall be taken as the distance from center to center of supports, but shall not be taken to exceed the clear span plus the depth of beam or slab. Brackets shall not be considered as reducing the clear span in the sense here intended.

The length of columns shall be taken as the maximum unsupported length.

(c) *Internal Stresses*. — As a basis for calculations relating to the strength of structures, the following assumptions are recommended:

1. Calculations should be made with reference to working stresses and safe loads rather than with reference to ultimate strength and ultimate loads.

2. A plane section before bending remains plane after bending.

3. The modulus of elasticity of concrete in compression within the usual limits of working stresses is constant. The distribution of compressive stresses in beams is therefore rectilinear.

4. In calculating the moment of resistance of beams the tensile stresses in the concrete shall be neglected.

5. Perfect adhesion is assumed between concrete and reinforcement. Under compressive stresses the two materials are therefore stressed in proportion to their moduli of elasticity.

6. The ratio of the modulus of elasticity of steel to the modulus of elasticity of concrete may be taken at 15.

7. Initial stress in the reinforcement due to contraction or expansion in the concrete may be neglected.

It is appreciated that the assumptions herein given are not entirely borne out by experimental data. They are given in the

interest of simplicity and uniformity, and variations from exact conditions are taken into account in the selection of formulas and working stresses.

For calculations relative to deflections the tensile strength of the concrete should be taken into account. For such calculations, also, a value of 8 to 12 for the ratio of the moduli corresponds more nearly to the actual conditions and may well be used.

**4. Tee Beams.** In beam and slab construction, an effective bond should be provided at the junction of the beam and slab. When the principal slab reinforcement is parallel to the beam, transverse reinforcement should be used, extending over the beam and well into the slab.

Where adequate bond between slab and web of beam is provided, the slab may be considered as an integral part of the beam, but its effective width shall be determined by the following rules:

(a) It shall not exceed one-fourth of the span length of the beam;

(b) Its overhanging width on either side of the web shall not exceed 4 times the thickness of the slab.

In the design of tee beams acting as continuous beams, due consideration should be given to the compressive stresses at the support.

**5. Floor Slabs.** Floor slabs should be designed and reinforced as continuous over the supports. If the length of the slab exceeds 1.5 times its width the entire load should be carried by transverse reinforcement. Square slabs may well be reinforced in both directions.<sup>1</sup>

The loads carried to beams by slabs which are reinforced in two directions will not be uniformly distributed to the supporting beam, and may be assumed to vary in accordance with the

<sup>1</sup>The exact distribution of load on square and rectangular slabs, supported on four sides and reinforced in both directions, cannot readily be determined. The following method of calculation is recognized to be faulty, but it is offered as a tentative method which will give results on the safe side. The distribution of load is first to be determined by the formula

$$r = \frac{l^4}{l^4 + b^4}$$

in which  $r$  = proportion of load carried by the transverse reinforcement,

ordinates of a triangle. The moments in the beams should be calculated accordingly.

**6. Continuous Beams and Slabs.** When the beam or slab is continuous over its supports, reinforcement should be fully provided at points of negative moment. In computing the positive and negative moments in beams and slabs continuous over several supports, due to uniformly distributed loads, the following rules are recommended:

(a) That for floor slabs the bending moments at center and at support be taken at  $\frac{wl^2}{12}$  for both dead and live loads, where  $w$  represents the load per linear foot and  $l$  the span length.

(b) That for beams the bending moment at center and at support for interior spans be taken at  $\frac{wl^2}{12}$ , and for end spans it be taken at  $\frac{wl^2}{10}$  for center and adjoining support for both dead and live loads.

In the case of beams and slabs continuous for two spans only, or of spans of unusual length, more exact calculations should be made. Special consideration is also required in the case of concentrated loads.

Where beams are reinforced on the compression side, the steel may be assumed to carry its proportion of stress in accordance with the provisions of Chap. VII, Section 3, *c*, paragraph 6. In the case of continuous beams, tensile and compressive reinforcement over supports must extend sufficiently beyond the support to develop the requisite bond strength.

**7. Bond Strength and Spacing of Bars.** Adequate bond

$l$  = length, and  $b$  = breadth of slab. For various ratios of  $l/b$  the values of  $r$  are as follows:

$l/b$	$r$
1	0.50
1.1	0.59
1.2	0.67
1.3	0.75
1.4	0.80
1.5	0.83

Using the values above specified, each set of reinforcement is to be calculated in the same manner as slabs having supports on two sides only, but the total amount of reinforcement thus determined may be reduced 25 per cent. by gradually increasing the rod spacing from the third point to the edge of the slab.



strength should be provided in accordance with the formula hereinafter given. Where a portion of the bars is bent up near the end of a beam, the bond stress in the remaining straight bars will be less than is represented by the theoretical formula.

Where high bond resistance is required, the deformed bar is a suitable means of supplying the necessary strength. Adequate bond strength throughout the length of a bar is preferable to end anchorage, but such anchorage may properly be used in special cases. Anchorage furnished by short bends at a right angle is less effective than hooks consisting of turns through  $180^\circ$ .

The lateral spacing of parallel bars should not be less than two and one-half diameters, center to center, nor should the distance from the side of the beam to the center of the nearest bar be less than two diameters. The clear spacing between two layers of bars should not be less than  $\frac{1}{2}$ -in.

**8. Shear and Diagonal Tension.** Calculations for web resistance shall be made on the basis of maximum shearing stress as determined by the formulas hereinafter given. When the maximum shearing stresses exceed the value allowed for the concrete alone, web reinforcement must be provided to aid in carrying the diagonal tension stresses. This web reinforcement may consist of bent bars, or inclined or vertical members attached to or looped about the horizontal reinforcement. Where inclined members are used, the connection to the horizontal reinforcement shall be such as to insure against slip.

Experiments bearing on the design of details of web reinforcement are not yet complete enough to allow more than general and tentative recommendations to be made. It is well established, however, that a very moderate amount of reinforcement, such as is furnished by a few bars bent up at small inclination, increases the strength of a beam against failure by diagonal tension to a considerable degree; and that a sufficient amount of web reinforcement can readily be provided to increase the shearing resistance to a value from three or more times that found when the bars are all horizontal and no web reinforcement is used. The following allowable values for the maximum shearing stress are therefore recommended, based on the working stresses, 5 on page 154.

(a) For beams with horizontal bars only 40 lb. per sq. in.

(b) For beams in which a part of the horizontal reinforcement is used in the form of bent-up bars, arranged with due respect to the shearing stresses, a higher value may be allowed, but not exceed 60 lb. per sq. in.

(c) For beams thoroughly reinforced for shear a value not exceeding 120 lb. per sq. in.

In the calculation of web reinforcement to provide the strength required under *c* above, the concrete may be counted upon as carrying one-third of the shear. The remainder is to be provided for by means of metal reinforcement consisting of bent bars or stirrups, but preferably both. The requisite amount of such reinforcement may be estimated on the assumption that the entire shear on a section, less the amount assumed to be carried by the concrete, is carried by the reinforcement in a length of beam equal to its depth.

The longitudinal spacing of stirrups or bent rods shall not exceed three-fourths the depth of the beam.

It is important that adequate bond strength be provided to develop fully the assumed strength of all shear reinforcement.

Inasmuch as small deformations in the horizontal reinforcement tend to prevent the formation of diagonal cracks, a beam will be strengthened against diagonal tension failure by so arranging the horizontal reinforcement that the unit stresses at points of large shear shall be relatively low.

**9. Columns.** It is recommended that the ratio of unsupported length of column to its least width be limited to 15.

The effective area of the column shall be taken as the area within the protective covering, as defined under Fireproofing or in the case of hooped columns or columns reinforced with structural shapes it shall be taken as the area within the hooping or structural shapes.

Columns may be reinforced by means of longitudinal bars, by bands or hoops, by bands or hoops together with longitudinal bars, or by structural forms which in themselves are sufficiently rigid to act as columns. The general effect of bands or hoops is greatly to increase the "toughness" of the column and its ultimate strength, but hooping has little effect upon its behavior within the limit of elasticity. It thus renders the concrete a safer and more reliable material and should permit the use of a

somewhat higher working stress. The beneficial effects of "toughening" are adequately provided by a moderate amount of hooping, a larger amount serving mainly to increase the ultimate strength and the possible deformation before ultimate failure.

The following recommendations are made for the relative working stresses in the concrete for the several types of columns:

(a) Columns with longitudinal reinforcement only, the unit stress recommended for axial compression under Working Stresses, Section 3.

(b) Columns with reinforcement of bands or hoops, as hereinafter specified, stresses 20 per cent. higher than given for *a*.

(c) Columns reinforced with not less than 1 per cent. and not more than 4 per cent. of longitudinal bars and with bands or hoops, stresses 45 per cent. higher than given for *a*.

(d) Columns reinforced with structural steel column units which thoroughly encase the concrete core, stresses 45 per cent. higher than given for *a*.

In all cases, longitudinal steel is assumed to carry its proportion of stress in accordance with Section 3. The hoops or bands are not to be counted upon directly as adding to the strength of the column.

Bars composing longitudinal reinforcement shall be straight, and shall have sufficient lateral support to be securely held in place until the concrete has set.

Where bands or hoops are used, the total amount of such reinforcement shall not be less than 1 per cent. of the volume of the column enclosed. The clear spacing of such bands or hoops shall not be greater than one-fourth the diameter of the enclosed column. Adequate means must be provided to hold bands or hoops in place so as to form a column, the core of which shall be straight and well centered.

Bending stresses due to eccentric loads must be provided for by increasing the section until the maximum stress does not exceed the values above specified.

**10. Reinforcing for Shrinkage and Temperature Stresses.** Where large areas of concrete are exposed to atmospheric conditions, the changes of form due to shrinkage (resulting from



hardening) and to action of temperature are such that large cracks will occur in the mass, unless precautions are taken to so distribute the stresses as either to prevent the cracks altogether or to render them very small. The size of the cracks will be directly proportional to the diameter of the reinforcing bars and inversely proportional to the percentage of reinforcement and also to its bond resistance per unit of surface area. To be most effective, therefore, reinforcement should be placed near the surface and well distributed, and a form of reinforcement used which will develop a high bond resistance.

### WORKING STRESSES

1. **General Assumptions.** The following working stresses are recommended for static loads. Proper allowances for vibration and impact are to be added to live loads where necessary to produce an equivalent static load before applying the unit stresses in proportioning parts.

In selecting the permissible working stress to be allowed on concrete, we should be guided by the working stresses usually allowed for other materials of construction, so that all structures of the same class but composed of different materials may have approximately the same degree of safety.

The stresses for concrete are proposed for concrete composed of one part Portland cement and six parts of aggregate, capable of developing an average compressive strength of 2000 pounds per square inch at 28 days, when tested in cylinders 8 inches in diameter and 16 inches long, under laboratory conditions of manufacture and storage, using the same consistency as is used in the field. In considering the factors recommended with relation to this strength, it is to be borne in mind that the strength at 28 days is by no means the ultimate which will be developed at a longer period, and therefore they do not correspond with the real factor of safety. On concretes, in which the material of the aggregate is inferior, all stresses should be proportionally reduced, and similar reduction should be made when leaner mixes are to be used. On the other hand, if, with the best quality of aggregates, the richness is increased, an increase may be made in all working stresses proportional to the increase in compressive strength at 28 days, but this increase shall not exceed 25 per cent.

2. **Bearing.** When compression is applied to a surface of concrete larger than the loaded area, a stress of 32.5 per cent. of the compressive strength at 28 days, or 650 pounds per square inch on the above-described concrete, may be allowed. This pressure is probably unnecessarily low when the ratio of the stressed area to the whole area of the concrete is much below unity, but is recommended for general use rather than a variable unit based upon this ratio.

3. **Axial Compression.** For concentric compression on a plain concrete column or pier, the length of which does not exceed 12 diameters, 22.5 per cent. of the compressive strength at 28 days, or 450 lb. per sq. in. on 2000 lb. concrete, may be allowed.

For other forms of columns the stresses obtained from the ratio given under Design, Section 9, may govern.

4. **Compression in Extreme Fiber.** The extreme fiber stress of a beam, calculated on the assumption of a constant modulus of elasticity for concrete under working stresses, may be allowed to reach 32.5 per cent. of the compressive strength at 28 days, or 650 lb. per sq. in. for 2000-lb. concrete. Adjacent to the support of continuous beams, stresses 15 per cent. higher may be used.

5. **Shear and Diagonal Tension.** Where pure shearing stress occurs, that is, uncombined with compression normal to the shearing surface, and with all tension normal to the shearing plane provided for reinforcement, a shearing stress of 6 per cent. of the compressive strength at 28 days, or 120 lb. per sq. in. on 2000-lb. concrete, may be allowed. Where the shear is combined with an equal compression, as on a section of a column at  $45^\circ$  with the axis, the stress may equal one-half the compressive stress allowed. For ratios of compressive stress to shear intermediate between 0 and 1, proportionate shearing stresses shall be used.

In calculations on beams in which diagonal tension is considered to be taken by the concrete, the vertical shearing stresses should not exceed 2 per cent. of the compressive strength at 28 days, or 40 lb. per sq. in. for 2000-lb. concrete.

6. **Bond.** The bonding stress between concrete and plain reinforcing bars may be assumed at 4 per cent. of the compressive strength at 28 days, or 80 lb. per sq. in. for 2000-lb. concrete;

in the case of drawn wire, 2 per cent. or 40 lb. on 2000-lb. concrete.

7. **Reinforcement.** The tensile stress in steel should not exceed 16,000 lb. per sq. in. The compressive stress in reinforcing steel should not exceed 16,000 lb. per sq. in., or 15 times the working compressive stress in the concrete.

In structural steel members, the working stresses adopted by the American Railway Engineering and Maintenance of Way Association are recommended.

8. **Modulus of Elasticity.** The value of the modulus of elasticity of concrete has a wide range, depending upon the materials used, the age, the range of stresses between which it is considered, as well as other conditions. It is recommended that in all computations it be assumed as one-fifteenth that of steel, as, while not rigorously accurate, this assumption will give safe results. (See table on next page.)

#### *Design of a T-beam*

It is required to design a beam of this description to carry a load of 2000 pounds, besides its own weight, per linear foot of span, which is 36 feet. If the depth and width of neither the web nor the flange be limited by special conditions, there are, with the amount of reinforcement, five quantities to be assumed or found. These quantities are:  $b$ ,  $b'$ ,  $t$ ,  $d$ , and  $p$ . Often the flange is a part of a floor and must be designed as a slab supported by two adjacent beams and so  $t$  is thus fixed. The part of the slab that may be considered as a part of the T-beam is indefinite, but practically the width is limited as described on page 148. The width of the web,  $b'$ , is limited by the condition that the steel must be properly spaced and also that the strength of  $b'd$  in shear shall be sufficient. The depth is limited practically by the requirements as to head room underneath, while  $p$  may be assumed within rather narrow limits. In this problem it is assumed that the beam is isolated and supported at the ends.

A concrete of medium quality will be assumed and working values of concrete in compression, in shear, and of steel in tension are taken as 600, 30, and 16,000 lb. per sq. in. respectively. In sections containing stirrups and bent-up bars the shear is increased to 90 lb. per sq. in.



## AREAS, WEIGHTS, AND SPACING OF ROUND RODS

Diameter, Inches	Area Square Inches	Perimeter, Inches	Weight per foot Pounds	For Depth of 10 Inches the Spacing, in Inches, is for Steel to the amount of				
				0.2%	0.4%	0.6%	0.8%	1.0%
$\frac{1}{4}$	.0491	.7854	.167	2.45	1.23	0.82	0.61	0.491
$\frac{5}{16}$	.0767	.9818	.261	3.83	1.92	1.28	0.96	0.767
$\frac{3}{8}$	.1104	1.1781	.376	5.52	2.76	1.84	1.38	1.104
$\frac{7}{16}$	.1503	1.3745	.511	7.51	3.76	2.50	1.88	1.503
$\frac{1}{2}$	.1963	1.5708	.668	9.82	4.91	3.27	2.45	1.963
$\frac{9}{16}$	.2485	1.7672	.845	12.42	6.21	4.14	3.10	2.485
$\frac{5}{8}$	.3068	1.9635	1.043	15.34	7.67	5.11	3.83	3.068
$\frac{11}{16}$	.3712	2.1599	1.262	18.57	9.28	6.18	4.64	3.712
$\frac{3}{4}$	.4418	2.3562	1.502	22.09	11.04	7.36	5.52	4.418
$\frac{13}{16}$	.5185	2.5526	1.763	25.93	12.96	8.64	6.48	5.185
$\frac{7}{8}$	.6013	2.7489	2.044	30.06	15.03	10.02	7.51	6.013
$\frac{15}{16}$	.6903	2.9453	2.347	34.53	17.26	11.51	8.63	6.903
1	.7854	3.1416	2.670	39.27	19.64	13.09	9.82	7.854
$1\frac{1}{8}$	.9940	3.5343	3.380	49.70	24.85	16.57	12.42	9.940
$1\frac{1}{4}$	1.2272	3.9270	4.172	61.36	30.68	20.45	15.34	12.272
$1\frac{3}{8}$	1.4849	4.3197	5.049	74.25	37.12	24.75	18.56	14.849
$1\frac{1}{2}$	1.7671	4.7124	6.008	88.35	44.17	29.45	22.09	17.671

## AREAS, WEIGHTS, AND SPACING OF SQUARE BARS

$\frac{1}{4}$	.0625	1.00	.212	3.13	1.56	1.04	0.78	0.625
$\frac{5}{16}$	.0977	1.25	.332	4.88	2.44	1.63	1.22	0.977
$\frac{3}{8}$	.1406	1.50	.478	7.03	3.56	2.34	1.76	1.406
$\frac{7}{16}$	.1914	1.75	.651	9.57	4.78	3.19	2.39	1.914
$\frac{1}{2}$	.2500	2.00	.850	12.50	6.25	4.16	3.13	2.500
$\frac{9}{16}$	.3164	2.25	1.076	15.82	7.91	5.27	3.96	3.164
$\frac{5}{8}$	.3906	2.50	1.328	19.53	9.76	6.51	4.88	3.906
$\frac{11}{16}$	.4727	2.75	1.607	23.63	11.81	7.88	5.91	4.727
$\frac{3}{4}$	.5625	3.00	1.913	28.12	14.06	9.37	7.03	5.625
$\frac{13}{16}$	.6602	3.25	2.245	33.01	16.50	11.00	8.25	6.602
$\frac{7}{8}$	.7656	3.50	2.603	38.28	19.14	12.76	9.57	7.656
$\frac{15}{16}$	.8789	3.75	2.988	43.94	21.97	14.65	10.98	8.789
1	1.0000	4.00	3.400	50.00	25.00	16.66	12.50	10.000
$1\frac{1}{8}$	1.2656	4.50	4.303	63.28	31.64	21.09	15.82	12.656
$1\frac{1}{4}$	1.5625	5.00	5.313	78.12	39.06	26.04	19.53	15.625
$1\frac{3}{8}$	1.8906	5.50	6.428	94.53	47.26	31.51	23.63	18.906
$1\frac{1}{2}$	2.2500	6.00	7.650	112.50	56.25	37.50	28.12	22.500

**Cross-section According to Shear.** The first requirement in making a design is to know the weight of the structure or, as this is always unknown, to assume a weight such that the preliminary design may not have to be much changed when the true weight becomes known. It is customary to assume the dead load as  $\frac{1}{3}$  or  $\frac{1}{2}$  the live load and, in this case, the former fraction will be used. With this assumption the cross-section at the end necessary to carry the vertical shear may be found. The dead load is  $\frac{1}{3} \times 2000$  lb. per linear foot and the shear is  $\frac{2}{3} \times 2000 \times 18 = 48,000$  lb. The section,  $b'd$ , is then  $48,000 \div 90 = 533$  sq. in. since all the shear is to be taken by the web. The web must be wide enough to give proper spacing for the reinforcing bars and is comparatively larger in small beams than in large ones, as the latter frequently have the steel in two horizontal rows and as the outside covering of concrete is constant. Usually, if  $d$  be taken as 2 or  $2\frac{1}{2}$  times  $b'$  in small beams and as 3 to 4 times  $d$  in large ones, it will be found that but little change in  $b'$  will be necessary when the computations are remade with known weights. If  $d = 3b'$  in this case,  $b'$  becomes  $\sqrt{533 \div 33} = 13.5$  and  $d$  is 40.5 inches.

**Flange Width According to Moments.** For the assumed weights, the moment is  $M = \frac{1}{8} \times 2670 \times 36 \times 36 \times 12 = 5,200,000$  lb. in. Now, in Plate III, page 51, either  $t$ ,  $b$ , or  $p$  may be assumed and, as  $t$  is not limited,  $p$  will be taken as 0.5 per cent. and  $t$ , usually between  $0.5 b'$  and  $0.75 b'$ , as 10 inches. Then  $N_3 = 0.139$  and  $b = 5,200,000 \div (.139 \times 40.5 \times 40.5 \times 60) = 38$  inches. The dimensions have now been determined tentatively and the weight may be recomputed. The area of cross-section is  $38 \times 10 + b'(h-10)$  in which  $h$  may be taken, for trial, as 44 inches. The weight of the beam is  $(38 \times 10 + 34 \times 13.5) 150 \div 144 = 875$  lb. per linear foot, and the whole load is 2875 lb. per linear foot, whereas 2670 was assumed. The bending moment, hence, will be increased 7.7 per cent. and  $p$  or one of the dimensions must be changed accordingly. The depth may be made 42 inches,  $b$  changed to 41.5 inches or  $p$  to 0.7 per cent. In this case the change will be made in the breadth. The shear is also somewhat increased and  $d$  may have to be changed on this account.

**The Reinforcement.** The area of reinforcement is  $41.5 \times 40.5 \times 0.005 = 8.4$  sq. in. This amount is supplied by seven

bars  $1\frac{1}{8}$  inches square having an area of  $7 \times 1.265 = 8.86$  sq. in. The steel will be arranged in two horizontal rows of three above and four below. The necessary width is from page 82,  $b = 1.125 (1.5 + 2.5 \times 4) = 12.94$  inches and so the assumed width is sufficient. The center of gravity of the bars is  $\frac{1}{4}$  of the vertical distance between the lines through the centers of the bars in the two rows. The clear distance between the two rows must be half an inch, so the whole depth of the beam is  $40.5 + 0.64 + 0.5 + 2 = 43.64$  or 44 inches as assumed. The depth at the end of the beam, to the middle of the lower bars, is  $41\frac{3}{8}$  in. The shearing stress is  $51,750 \div (41.4 \times 13.5) = 91.2$  lb. sq. in. So  $b'$  is made 14 in.

**Points for Bending up Bars.** The first bars to be bent up are those in the upper row nearest the middle of  $b'$ ; in this problem

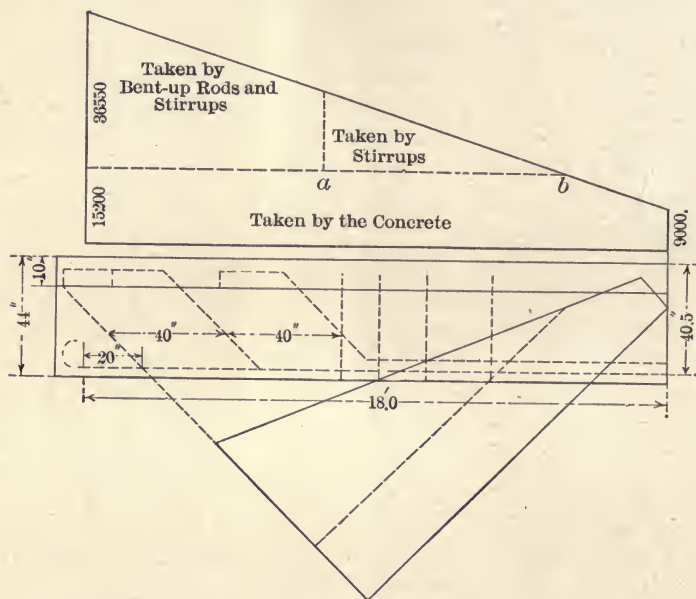

FIG. 59.

one bar will be bent up, then others in pairs. In Fig. 38 it is seen that  $\frac{1}{4}$  of the bars may be bent up at  $0.19l$ ,  $\frac{3}{7}$  at  $0.34$ , and  $\frac{5}{7}$  at  $0.42l$  or at 6.9, 12.3, and 15.2 feet from the middle of the beam. As was stated on page 77, the spacing of the web reinforcement depends upon the strength of the bar and of the bond



and also upon the depth of the beam. As these bars are, as is usual, to be bent to an angle of  $45^\circ$  with the horizontal, they cannot be spaced more than 40.5 inches apart, and the first bar must be continued straight beyond the length required by the bending moment.

**Spacing the Web Reinforcement.** The vertical shear at the end of the beam is  $18 \times 2875 = 51,750$  pounds and at the middle  $v = 2000 \times 18 \div 4 = 9000$  pounds. The value of  $j$  is, by (24) page 49,  $j = d - [3 \times 40.5 \times 15 - 20 (15 + 16.7)] t \div [6 \times 40.5 \times 15 - 30 (15 \times 16.7)] = 36.3$  inches. The concrete is capable of carrying  $30 \times 36.3 \times 14 = 15,200$  pounds of shear while the web reinforcement takes the remainder or 36,600 pounds. The diagram of shears is shown in Fig. 59. The bent-up rods nearest the ends should pass over the support well below the neutral axis and so the point of bending should not be more than  $\frac{1}{2}d$  from the support. The shear to be carried by these two rods may, then, be taken as about 37,000 pounds. From (62)  $s = 2 \times 1.265 \times 16,000 \times 36.3 \div (37,000 \times .707) = 55$  inches, so the bars will be spaced 40 inches apart. At 80 inches from the support the shear is 21,000 pounds and  $s = 1.265 \times 16,000 \times 36.3 \div (21,000 \times .707) = 49$  inches. As both values of  $s$  are greater than the depth the spacing will be 40 inches, as shown, the first bend being not over  $\frac{1}{2}d$  from the support.

**Bond Stresses of the Bars.** As has been shown before, the grip of the bent-up rods should be about 50 diameters, which distance is secured by bending them in the upper part of the beam as shown in Fig. 59. The rods nearest the end of the beam may be bent as are the others if the beam extends far enough over the support.

**The Stirrups.** In Fig. 59 it is seen that a part of the shear is provided for by neither the concrete nor by the bent-up

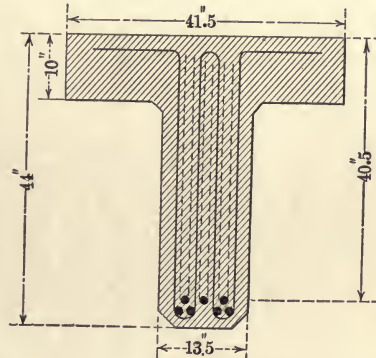

FIG. 60.

rods and so stirrups are to be inserted. To secure better bond small rods are used and a diameter of  $\frac{3}{8}$  inch will be selected. Where the first stirrup is to be placed the shear is about 18,000

pounds. The stirrups will be made in two continuous loops, passing under the horizontal rods as shown in Fig. 60. Then the area is  $4 \times 0.11 = 0.44$  square inches. Substituting in (59)  $s = 0.44 \times 16,000 \times 36.3 \div 18,000 = 14.2$  inches. Since the shear to be carried by the stirrups decreases uniformly over about 80 inches, the average spacing will be  $14.2 \times 2 = 28.4$  inches, and three spaces and four stirrups will suffice. The triangle in the shear diagram, representing the shear taken by the stirrups, is to be divided into three equal areas or, in general, into  $n - 1$  trapezoids and one triangle having equal areas,  $n$  being the number of spaces. If  $l'$  be the distance  $ab$ , the horizontal dimensions of these figures will be

$$l' \frac{\sqrt{n} - \sqrt{n-1}}{\sqrt{n}}, l' \frac{\sqrt{n-1} - \sqrt{n-2}}{\sqrt{n}},$$

$$l' \frac{\sqrt{n-2} - \sqrt{n-3}}{\sqrt{n}} \dots \dots \frac{l'}{\sqrt{n}}$$

the first expression being, practically, the same as  $s$  computed from (59), and the last one the base of the triangle. The numerical equivalents of the above expressions are tabulated in Fig. 61 for values of  $n$  not exceeding 10, and beyond this number the smaller divisions become nearly uniform.

In this case there are three spaces which will be given by multiplying  $l'$  by the fractions in the column having 3 at the top or  $80 \times .578 = 46$ ,  $80 \times .238 = 19$  and  $80 \times .184 = 15$ . These spaces may be laid off on  $l$  and the stirrups are placed at the centers of gravity of the trapezoids so formed, giving the spacing shown in the figure.

NUMBER OF SPACES									
1	2	3	4	5	6	7	8	9	10
1.00	.293	.184	.134	.105	.087	.074	.064	.057	.051
	.707	.238	.159	.120	.096	.080	.070	.061	.054
		.578	.207	.142	.109	.089	.075	.066	.058
			.500	.185	.131	.101	.084	.071	.062
				.448	.169	.121	.096	.079	.068
					.408	.157	.112	.089	.075
						.378	.146	.106	.085
							.353	.138	.101
								.333	.130
									.316

Table Giving Spacing of Stirrups

Parts of  $l'$

FIG. 61.

It is usual to insert stirrups also in the part of the beam between  $a$  and the end as additional security. This is to be done here, although the figure shows only those taking the shear not otherwise provided for. The minimum spacing is to be continued to the support.

If the numbers in Fig. 61 be divided by the sine of the angle the bent-up rods make with the horizontal, they apply to the spacing of such rods.

**Investigation for the Flange.** Should it be possible that the load may be applied to one flange rather than uniformly over the whole top it may be necessary to provide transverse reinforcement in the upper side of the beam. If half the live load be placed toward one side of the top, and one foot of length be considered as a cantilever beam having a length of 14 inches, the bending moment will be  $(1000 + 10 \times 14 \times 150) \times \frac{1}{2} \times 14 = 8000$  lb. in. From (7) page 39,  $A$  is found to be 0.08 square inches per linear foot. If the stirrups be extended transversely some distance beyond the width of the web, ample security will be given. In case the flange is a part of a floor system the reinforcement in the lower side of the slabs is bent up and continued over the beams. An angle, such as those between the flange and the stem, is always a source of weakness and it is good practice to bevel, or round off, the corners of the forms to make the change in depth less abrupt.

**Diagram for Solution of Slabs and Beams.** For office use it is desirable to have a quick and accurate method of finding dimensions of beams and slabs without making use of the ordinary formulas. In Vol. LIV, Part E, page 537, of *Trans. Am. Soc. Civil Engineers*, Dr. F. von Emberger shows a diagram which, drawn to proper scale, is very useful in this connection. This diagram is shown to small scale in Fig. 62. As the article mentioned above is readily accessible to very many no description of the method of construction will be given here.

Several examples are given showing the use of the diagram which is readily constructed from the given equations.

**Sequence of Computations in the Design of T-beams.** To the end that such work shall proceed in logical order, the steps, as given above, will be repeated in the form of instructions.



**General Instructions.** All computations should be in a notebook, one side of the leaves being reserved for miscellaneous and trial operations, while finished results are on the opposite page.

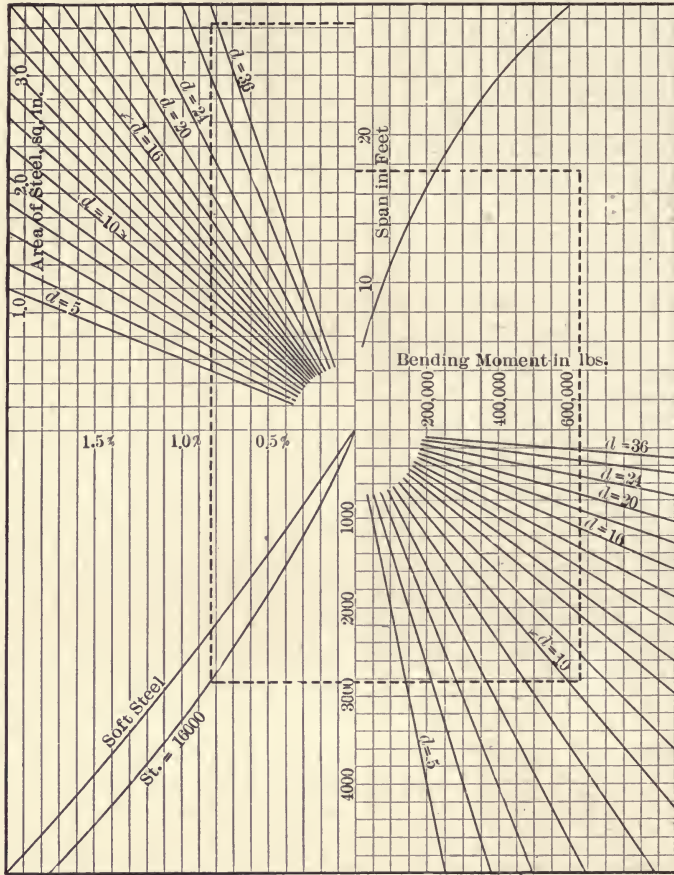

FIG. 62.

The size of the trimmed sheet of paper shall be — in. × — in.

The dimensions of the border line shall be — in. × — in.

The scale to be used shall be — in. = 1 foot.

The plan shall be in the lower left hand corner.

The side elevation shall be in the upper left hand corner.

The end elevation, or cross-section, shall be in the upper right hand corner.

The title, bill of material, and notes shall be in the lower right hand corner.

The shear and moment diagrams shall be below the side elevation.

**Data.** Isolated T-beam, supported at the ends. Length of span — feet. Weight of concrete, 150 pounds per cubic foot. Live load — pounds per linear foot,  $C = 500$  to  $650$ ,  $S_t = 15,000$  to  $16,000$ , and  $v = 30$  to  $40$  pounds per square inch. In sections through reinforcement  $v = 90$  to  $120$  pounds per square inch. Bond stress  $80$  pounds per square inch,  $n = 15$ .

**The Order of Computation.** The calculations are taken up as follows:

1. Assume the dead load to be  $\frac{1}{3}$  or  $\frac{1}{2}$  of live load.
2. Find the maximum shear at supports.
3. Compute the web section,  $b'd$ , to support the shear.
4. Assume relative proportions for  $b'$  and  $d$ . The depth is usually from  $2b'$  to  $2\frac{1}{2}b'$  for small beams and from  $3b'$  to  $4b'$  for large ones.
5. Choose thickness of the flange, usually from  $\frac{1}{2}b'$  to  $\frac{3}{4}b'$ .
6. Compute the bending moment for assumed dimensions,  $M = \frac{1}{8}wl^2$ .
7. Assume  $b$  or  $p$  and find  $p$  or  $b$  from Plate III, page 51.
8. Compute the width of web from the spacing of the reinforcement and change the previous assumption if necessary. Allow 2 inches of concrete outside of rods in beams of more than 20 inches depth, and use spacing according to page 82. Find center of gravity of reinforcement.
9. Find total depth,  $h$ , and compute the dead load. With the new loads, recompute the shear and bending moment and change assumed dimensions accordingly.
10. Determine the points at which rods may be bent up, using Fig. 38. Provide the straight rods with sufficient length of grip, making hooks at the ends if necessary. Use (66).
11. Find  $j$  and  $k$  from (24) and (26).
12. Construct the shear diagram and determine the parts of the shear to be carried by the concrete, the bent-up rods, and the stirrups. The rods are to be bent up in pairs. Those in the upper row and near the middle of  $b'$  are bent up first.

13. Determine the spacing of the bent-up rods and the stirrups, using (62) and Fig. 61. The spacing of rods and stirrups must not exceed  $d$  and  $\frac{3}{4}d$  respectively.

14. Investigate the flange transverse bending stresses under eccentric loading and for shear in the plane of the side of the web produced.

15. Design the support so that the vertical compressive stress shall not be excessive, and that sufficient anchorage for reinforcement be secured. Usually the support should be, at least,  $b' \times \frac{1}{2}d$ .

#### PROBLEMS

68. Prove that the spacing given in Fig. 61 may be accomplished graphically as follows: Let  $l'$  be divided into  $n$  equal spaces, and from each division point let perpendiculars be erected to the semicircle drawn with  $l'$  as a diameter. With one end of  $l'$  as a center, arcs are drawn from the tops of the perpendiculars to  $l'$ , thus dividing  $l'$  as specified.

69. Compute the cost of the T-beam designed above, using concrete in place at \$8 per cubic yard, and steel in place at 3 cents per pound.

70. Find the minimum cost if  $t$  be made to vary between 6 inches and 12 inches, and  $p$  be the other variable.

71. If  $t$ ,  $b$ , and  $b'$  be constant, find  $p$  and  $d$  for minimum cost.

**Design of Reinforced Retaining Walls.** The design of retaining walls is not nearly as accurate and satisfactory as that of dams and reservoir walls. The reason is that little is known regarding the lateral pressure of the earth filling except in special cases.<sup>1</sup> Many valuable experiments have been made in attempts to correct the present uncertainty regarding the action of loose material that is restrained to a slope steeper than that of its natural repose, but no universally accepted rules have resulted. If materials described as sand, loam, shingle, clay, and so forth, were the same everywhere and at all times, it would be comparatively easy to so tabulate the results of observations and experiments that formulas for pressure, that might be depended upon, could be deduced, but such is not the case. Even in a given bank, the pressure varies rapidly and decidedly with changes of conditions as to moisture, water, heat, and frost. In some cases the initial pressure is the maximum while, on the other hand, retaining walls have failed after decades of seeming stability.

<sup>1</sup> See Vol. LXX. *Transactions Am. Soc. C. E.*, 1910.



The lateral pressure of loose material undoubtedly varies somewhat with the unit weight, but more with the degree of fluidity, as indicated by the angle of repose which appears as a factor in nearly all such formulas. As the coefficient of friction, or the tangent of the angle of repose is not generally known, it is customary to design solid masonry retaining walls according to precedent rather than in accordance with any formula for earth pressure. Reinforced concrete retaining walls are of a newer type than the solid, and so there are fewer examples of designs that have proved satisfactory. It would, then, seem that the proper method to pursue is to design the reinforced wall to have the same degree of security as has been determined for the solid type. This may be done by finding the pressure of a backing against a vertical plane, of height equal to that of the wall, through the back of the footing which, combined with the weight of the wall and of the prism of earth between the wall and the vertical plane mentioned above, will cause the resultant to pass through the outside of the middle third of the base. The pressure of the earth against the vertical may be taken as  $\frac{1}{2} w' h^2$ , in which  $w'$  is the unit weight of a fluid that would cause the same pressure, horizontally, as does the earth and  $h$  is the height of the wall. The prism is supposed to act vertically, without horizontal pressure in addition to that of the earth back of it. This method of analysis might be called that of finding the equivalent liquid pressure of earth, but it is that only to the extent of considering the horizontal pressure as varying as the square of the height. The unit weight of the prism is the actual unit weight which is very different from the liquid unit weight to be computed for the earth behind the prism.

A masonry wall, with suitable foundations, is usually considered of proper cross-section if the top has a thickness sufficient to withstand shocks to which it may be liable, as two to three feet, a nearly vertical face, as 1 to 12, and a width of base equal to four-tenths or five-tenths of the height.<sup>1</sup> For such a wall it may be readily shown that  $w'$  is from 18 pounds to 25 pounds per cubic foot when the resultant pressure passes through the outside of the middle third of the base, and the weights of

<sup>1</sup> See Bulletin No. 108, Am. Railway Engineering and Maintenance of Way Association, February, 1909.

masonry and of the earth prism are 150 and 100 pounds respectively per cubic foot. With these assumptions the pressure between the earth and the masonry at the foundation is, at the outer edge, two times the average pressure and is zero at the inner edge.

Reinforced concrete retaining walls are, in general, of two types, as shown in Fig. 63. The cantilever type is shown in (a), and the counterpart type in (b). The former is seldom used

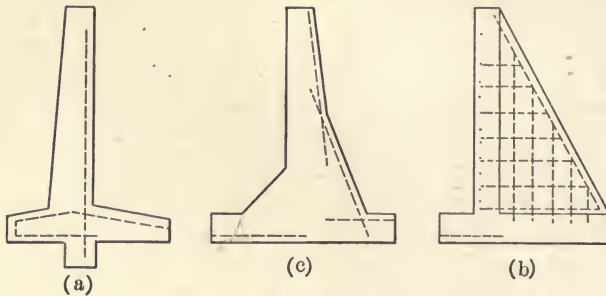

FIG. 63.

with a height exceeding 25 feet, and the latter is used for both high and low walls. The semi-gravity type is shown in (c). This is used exclusively on some railroads in the middle West.

#### *Design of a Cantilever Retaining Wall*

Let the height of the wall above ground be 16 feet, and let the top of the footing be 2 feet below ground. The unit horizontal pressure of the earth backing is assumed to be 25 pounds per square foot. The safe compressive strength of the concrete is 400 pounds per square inch, the allowable tensile strength of the steel is 12,500 pounds per square inch, the bond strength is 80 pounds per square inch, the diagonal tensile strength of the concrete is 40 pounds per square inch, and  $n$  is 15. The weight of concrete is 150, and of earth is 100 pounds per cubic foot.

The wall is seen to be composed of three cantilevers, the vertical wall restraining the earth, the front of the footing which is in tension on the under side, and the rear of the footing which is in tension on the upper side. These will be designed in order.

**The Vertical Wall.** The pressure of the earth will be possibly dependent upon the amount of surcharge above the level of

the top of the wall, so the unit horizontal earth pressure is assumed rather large, 25 pounds per square foot of vertical projection of the wall. As such a wall weighs less than a solid wall of the same height, it may be tentatively assumed that the base will be  $0.45 \times 20 = 9$  feet. The bending moment of the earth against the vertical wall at the top of the footing will be  $M = 12.5 \times 18^3 \times 12 \div 3 = 291,600$  lb. in. If  $p$  be taken as 0.005 in Plate I,  $t = \sqrt{291600 \div (.144 \times 12. \times 400)} = 20.5$  inches to the middle of the steel, or 23 inches over all. The thickness required to resist bending varies as  $h^3$ , and so decreases rapidly toward the top, but considerable thickness is required at the top to resist shocks, frost, and so forth, and this is here taken as 10 inches. The inside batter is made uniform to reduce the price of the forms, so the thickness at 6 feet and 12 feet from the top is 14.3 inches and 18.7 inches respectively.

**Reinforcement in Vertical Wall.** If the reinforcement be made up of  $\frac{7}{8}$  inch round rods, the spacing at the footing will be  $0.6013 \div (0.005 \times 20.5) = 5.85$  inches. At a point 12 feet below the top the bending moment is 87,000 lb. in., and at 6 feet below it is 11,000 lb. in. Referring to Plate I or (13), it is seen that less than  $\frac{1}{3}$  and  $\frac{1}{6}$  of the reinforcement used at the footing will be sufficient at these points respectively. So every third rod is carried up 6 feet and every sixth one to the top of the wall. The most important point to be considered in the design of this type of retaining wall is the anchoring of the rods in the footing. This question will be taken up when the dimensions of the latter are determined.

It will be noted that making a uniform batter decreases the necessary amount of steel and allows the use of simpler and cheaper forms. Longitudinal rods are inserted to prevent large cracks. These are more liable to occur near the top and on the outside, and so these parts are more heavily reinforced than the others. If  $p = 0.004$  be inserted at the top, the spacing of  $\frac{1}{2}$ -inch round rods will be  $0.196 \div (10 \times 0.004) = 5$  inches. This average will be preserved if the spacing be 8 inches in front and 12 inches at the back of the wall.

**Shear at Top of Footing.** The horizontal pressure against a foot of wall is  $\frac{1}{2} \times 25 \times 18 \times 18 = 4050$  pounds, and the unit shear is  $4050 \div (12 \times 20.5) = 16.5$  lb. sq. in., which may be carried by the concrete.



**Design of the Footing.** Frequently the projection of the footing in front of the wall is limited by property lines; otherwise, with a given length of base, the stability of the wall is made maximum by varying  $EC$  and  $DB$  in Fig. 65. For sim-

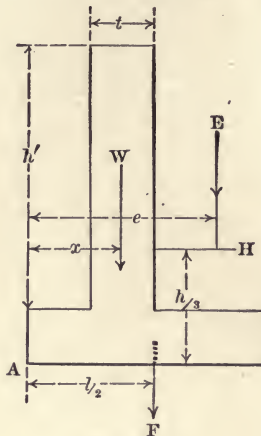

FIG. 64.

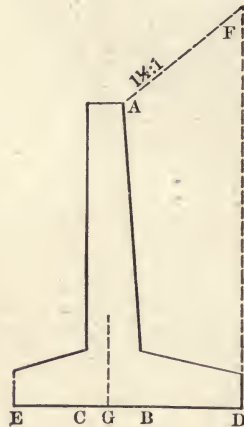

FIG. 65.

plicity, let the section be as in Fig. 64, and let moments be taken about  $A$ . Then  $Wx + Ee + Fl/2 - Hh/3 = M$ .

$$\text{But } e = \frac{x}{2} + \frac{l}{2} + \frac{t}{4} \text{ and } E = w'h' \left( l - x - \frac{t}{2} \right)$$

also  $w$  and  $w'$  are the unit weights of masonry and of earth,

$$M = h'twx + h'w' \left( \frac{l^2}{2} - \frac{x^2}{2} - \frac{tx}{2} - \frac{t^2}{8} \right) + \frac{Flw}{2} - \frac{Hh}{3}$$

$$\frac{dM}{dx} = h'tw - h'w' \left( x + \frac{t}{2} \right) = 0$$

$$\text{then } x = t \left( \frac{w}{w'} - \frac{1}{2} \right)$$

and, for usual values,  $x = t$  for maximum stability. It is usually attempted to bring the resultant of all forces inside the middle third of the base, and to have this point under the vertical part of the wall. In this problem the base was assumed to be 9 feet in length. The projection in front will be taken as 2.5 feet. The height of earth over  $D$  becomes 21.8 feet. The weights of the prism of earth, the wall, and the footing are 10,300, 3710, and 2700 pounds respectively. These weights are found to act at distances of 3.55, 0.16, and 1.5 feet respectively from

the outer third point. The resisting moment about this point is then  $10,300 \times 3.55 + 3710 \times 0.16 + 2700 \times 1.5 = 41,240$  lb. ft. The overturning moment about the same point is  $12.5 \times 20^3 \div 6 = 33,333$  lb. ft., and the base need not be changed in length. The weights act at  $41,240 \div (10,350 + 3710 + 2700) = 2.48$  feet from the outer edge of the middle third. The pressure of the earth is 5000 pounds, and acts at 6.67 feet above the bottom of the footing. The resultant may be drawn to scale, as shown in Fig. 67, and the point of application is found to be 0.48 feet to the right of the outer edge of the middle third of the base, and so the assumption of 9 feet as the length of the base was proper. Had the resultant fallen outside the middle third a few trials would have indicated the amount to be added to the base at each end.

**The Bearing Power of the Soil.** Aside from the question of overturning on account of the horizontal pressure of the earth, the footing must be of such length as to bring the unit pressure within the safe bearing power of the earth beneath. The unit pressure at the outer edge of the wall depends upon the weight of the wall and the prism of earth above it, and also upon the eccentricity of the point of application of the forces above. When the resultant is at the edge of the middle third the maximum pressure on the base is double the mean. If the resultant be outside the  $\frac{1}{3}$  point and  $e$  the eccentricity, the maximum pressure is given by  $2W \div 3(l/2 - e)$ , and if inside, by  $W/l + 6We/l^2$ . In this problem the maximum pressure on the soil will not exceed  $16,710 \times 2 \div 9 = 3715$  pounds per square foot, if the resultant pass through the  $\frac{1}{3}$  point, or 3130 pounds per square foot if the forces be as computed above.

**The Outer Cantilever.** The length of the cantilever is taken as  $2.5 + (1.9 \div 2) = 3.5$  feet. The downward weight is  $2 \times 2.5 \times 100 + 2.5 \times 2 \times 150 = 1250$  pounds, having a lever arm of 2.2 feet. The upward pressure of the earth is  $(3150 + 2150) \times 3.5 \div 2 = 9300$  pounds, having a lever arm of 1.86 feet. The moment about the point under the middle of the vertical slab is  $9300 \times 1.86 - 1250 \times 2.2 = 15,350$  lb. ft. The effective depth of the footing may be taken at  $24 - 2.5 = 21.5$  inches, as assumed, and this is to be investigated. A convenient way of anchoring the rods in the vertical slab is to bend them into the horizontal to form the reinforcement of the outer cantilever.

If all these rods be used in this way the value of  $p$  is  $0.6013 \div (5.85 \times 21.5) = 0.0047$ . Using Plate I,  $15,350 \times 12 = 0.140 \times 400 \times 12 d^2$  and  $d$  is 16.6 inches. This shows that not all the vertical bars are needed for this purpose, but they serve to reduce the bond stress. In Plate I,  $r$  is 33.5 and  $S_t = 400 \times 33.5 = 13,400$  lb. sq. in. If the working bond stress be 80 lb. sq. in., the length of grip required is  $\pi \cdot \frac{7}{8} \cdot 80 x = 13,400 \times 0.6013$  and  $x = 37$  inches. This distance is secured by turning the rods upward as shown. The cantilever must be examined as to the bond stress developed. The formula is (2), page 25, and the shear is found to be 7000 pounds, at the point  $C$ , for a linear foot of wall. Then  $u = 7000 \div (21.5 \times \frac{7}{8} \times 2.75 \times 12/5.85) = 66$  lb. sq. in., which is not in excess of the allowable bond stress. Had this exceeded 80 pounds per square inch the depth at the edge of the vertical slab would have been increased accordingly. The depth necessary to take the vertical shear is  $7000 \div (12 \times 35) = 16.7$  inches, which is also less than that assumed. Half way out, the shear is 3730 pounds, which requires a depth of 9.5 inches to keep the bond stress at 80 lb. sq. in., and 9.0 inches to keep the shearing stress at 40 lb. sq. in. As inequalities in the character of the soil may increase the unit pressure at some points, the depth at the end of the cantilever will be made 12 inches, and that at the vertical slab 24 inches as assumed.

**The Inner Cantilever.** Considering the whole prism of earth above this part of the footing to be supported by the earth below  $BD$ , the shear at  $B$  is  $10,350 + 1380 - 5750 = 5980$  pounds. Then the spacing of  $\frac{7}{8}$  inch round rods will be in accordance with (2)  $m_o = V \div u_j = 5980 \div (80 \times \frac{7}{8} \times 21.5) = 4.0$  inches. As the circumference of the rod is 2.75 inches,  $m = 4.0 \div 2.75 = 1.45$ , and the spacing is  $12 \div 1.45 = 8.25$  inches. The depth necessary to keep the unit shearing stress at 40 pounds per square inch is  $V \div (35 \times 12 d)$ , so the depth becomes  $d = 14.3$  inches which is less than that assumed. With  $\frac{7}{8}$  inch rods spaced at  $8\frac{1}{4}$  inches the per cent. of reinforcement is  $0.6013 \div (21.5 \times 8.25) = 0.34$ . In Plate I it is seen that  $N_1$  is 0.124, so, the moment of the prism of earth, the footing and the upward pressure under the footing being 195,000 lb. in., the required depth is  $d^2 = 195,000 \div (0.124 \times 400 \times 12) = 328$  and  $d = 18.1$  inches, also less than was assumed. If  $d = 18.1$



inches be adopted, the spacing of the reinforcement will be  $8.25 \times 18.1 \div 21.5 = 6.9$  inches. In the problem, the depth of both sides of the footing will be 24 inches at the vertical slab, and 12 inches at the extremities.

**Anchoring the Reinforcement.** In this type of retaining wall it is most important that the ends of the rods be secure against slipping. Fig. 66 shows common methods of placing the steel in the footing.

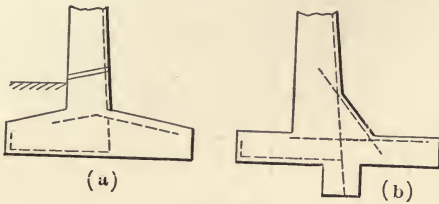

FIG. 66.

If the earth back of the wall be put in place before the outer footing is covered, the projection shown below the footing slab in (b) may be necessary to prevent sliding, and it is often made to serve this purpose and also to provide length of grip for the vertical rods. This is, perhaps, the most common design for footings. The arrangement shown in (a) may be used only when the footing is deep in comparison with the height of the wall. If the reinforcement be of large diameters there is some advantage in using only straight rods, but sizes up to one inch are readily bent to any desired angle.

**Drainage.** As the pressure of the earth against the wall increases greatly with the addition of moisture in the backing, it is well to provide means of carrying off any accumulation of water that may tend to exist back of the wall. This is done by means of drain pipe extending through the wall just above the level of the ground, as shown in Fig. 66 (a).

**Forms.** A design for a form for this variety of wall is shown in Fig. 68. This design was made by the engineers of the Isthmian Canal Commission for a reservoir wall.

#### *Sequence of Work in Design of Cantilever Retaining Wall*

**General Instructions.** Size of sheet is 22"  $\times$  30" — border 28"  $\times$  30".

Scale of drawing is 1 inch = 4 feet.

The cross-section is in the upper left hand corner. Under this the diagram of pressures on the ground, and the plan showing reinforcement in the footing below.

In the upper right hand corner is the elevation of ten feet of

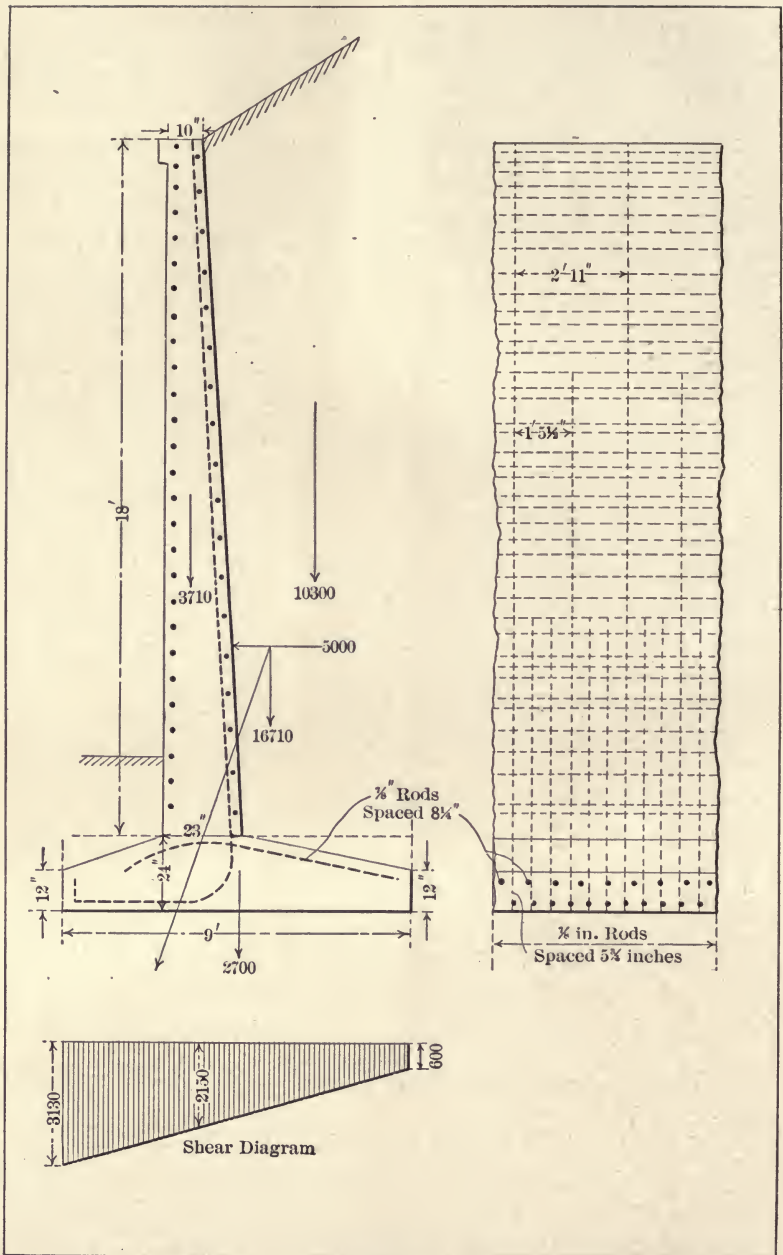

FIG. 67.

wall, showing spacing and length of reinforcing bars. Below this is a bill of material for ten feet of wall. The title is in the lower right hand corner.

**Data.** Gravel foundation. Allowable pressure 5 tons per square foot. Earth filling back of wall weighs 100 pounds per cubic foot. The surcharge is  $1\frac{1}{2}$  to 1. The pressure of the earth against the wall is assumed  $\frac{1}{2} \times 25 \times h^2$ .

Concrete weighs 150 pounds per cubic foot.  $C = 400$ ,  $S_t = 12,500$ ,  $u = 80$ , and  $v = 40$  pounds per square inch,  $n = 15$ . The height of wall is —. The computations are for one linear foot of wall.

**Design — The Vertical Wall.** Assume  $0.45 h$  or  $0.5 h$  as

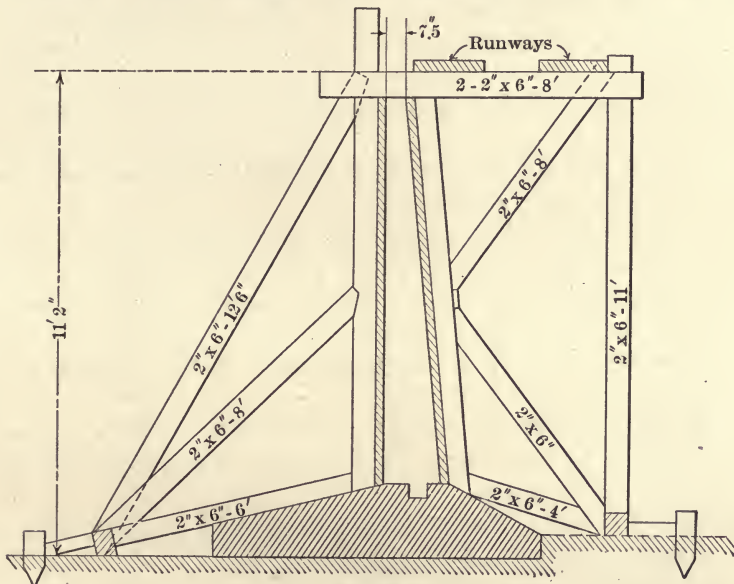

FIG. 68.

length of the base, and locate the vertical slab nearly over the outer  $\frac{1}{3}$  point. Assume the thickness of the base, as  $h/10$ , or sufficient to extend below frost.

Assume a thickness of 10 inches to 12 inches at the top of the wall and compute the thickness at the top of the footing. In high walls one or two thicknesses at intermediate heights may be computed and the batter determined accordingly. About 0.005 is a common value for  $p$ .



Compute the weight of the vertical wall, the footing, and the earth prism. Also find the horizontal pressure of the earth against the wall, and the lever arms of the weights with the  $\frac{1}{3}$  point as a center. Compute the moments of external forces about the outer  $\frac{1}{3}$  point as a center, and change the length of the base if the overturning moment be in excess, or the safe earth pressure under the footing be exceeded.

Determine the spacing of the vertical reinforcement.

Determine the spacing of the horizontal reinforcement for temperature stresses, using  $p = 0.004$ . About  $\frac{2}{3}$  of this should be on the face of the wall. Test the wall at the top of the footing for shear and bond stresses.

**The Outer Cantilever.** Compute the vertical pressure on the ground under the footing at each end, and draw the pressure diagram.

Find the shear under the inner and outer edges of the vertical wall.

Compute the upward pressures on the footing on each side of the middle of the vertical wall.

Take the center of moments under the middle of the vertical wall, and with an assumed value of  $p$ , find the depth of the footing for bending, for shear and for bond stresses. Change the assumed depth if found necessary.

Make the thickness at the outer edge of the cantilever at least 12 inches.

**The Inner Cantilever.** Make computations similar to those for the outer cantilever and check assumed depth for moments, for shear, and for bond.

Make the inner edge 12 inches deep, and connect with a computed depth at the vertical slab.

**The Reinforcement.** Compute the length of grip necessary to secure the ends of the vertical rods according to one of the ways shown in Fig. 66, and provide hooks if space for grip be limited.

Allow a covering of  $1\frac{1}{2}$  to 2 inches of concrete over all reinforcement.

#### *Design of a Counterfort Retaining Wall*

It is not common to construct retaining walls of the cantilever type higher than 25 feet, although there might be some economy

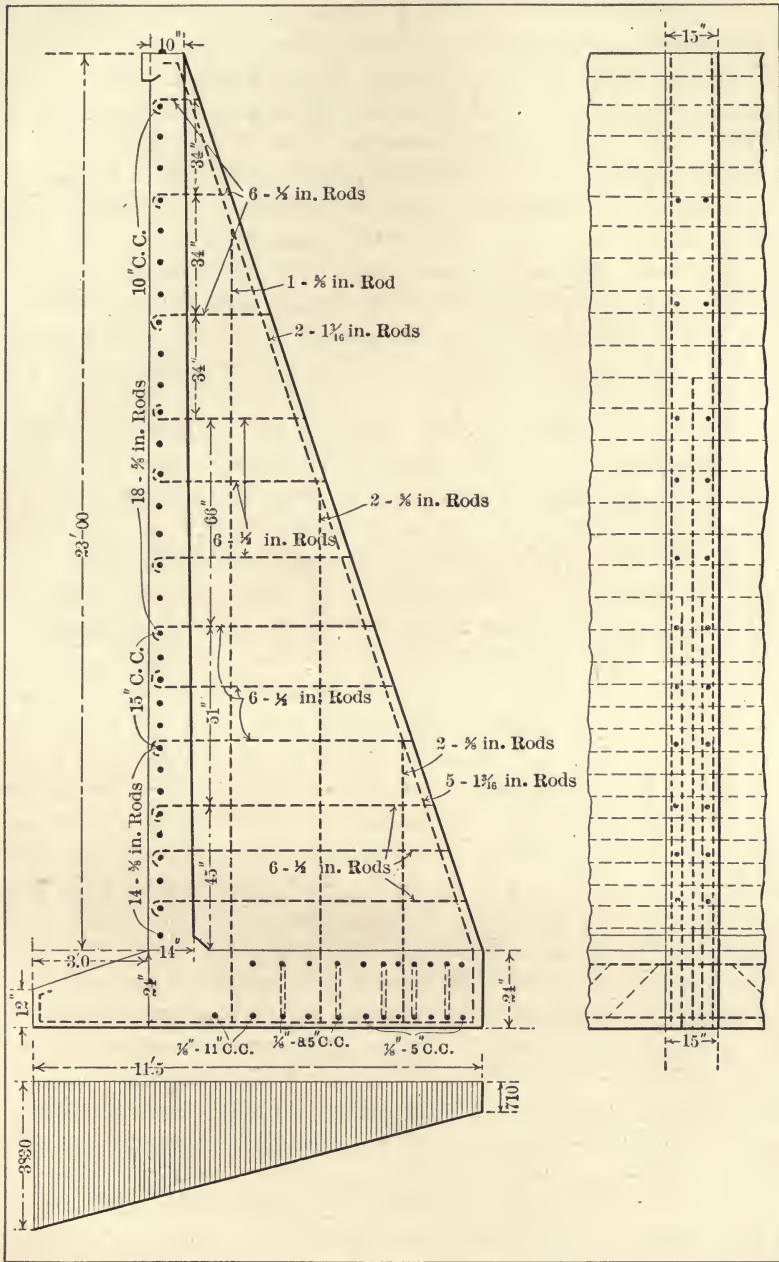

FIG. 69.

in so doing. In the wall with counterforts the vertical slab is a horizontal beam fixed to the counterforts and supporting a horizontal load. The inner footing is also a simple, rather than a cantilever beam. The outer footing is a cantilever and the counterfort is usually so considered.

**The Vertical Slab.** The unit horizontal pressure of the earth will be taken, as before, at 25 pounds per square foot. The height is 25 feet, and the base will be assumed to be  $25 \times 0.45 = 11.5$  feet. The safe stress on the steel will be 16,000 lb. sq. in., and for the concrete 500 lb. sq. in. The values of bond and shearing strength will be 80 and 40 lb. sq. in. respectively, and  $n$  is 15. The safe pressure on the ground is assumed to be 5 tons per square foot.

Assuming the footing to be 2 feet thick and the counterforts 10 feet apart, center to center, the bending moment on the slab at the top of the footing will be for a breadth of 12 inches,  $M = \frac{1}{16} 25 \times 23 \times 10 \times 10 \times 12 = 69,000$  lb. in. If  $p$  be 0.005, Plate I gives  $69,000 = 0.144 \times 500 \times 12 d^2$ , or  $d = 9$  inches. Adding 2.5 inches outside the middle of the rods, the thickness is 11.5 inches. This thickness must be tested for shear and for bond. The shear is  $25 \times 23 \times 5 = 2875$  pounds if the thickness of the counterfort be neglected. Then  $v = 2875 \div (12 \times 9) = 26.7$  pounds per square inch, and the thickness is sufficient. If the reinforcement be  $9 \times 12 \times 0.005 = 0.54$  sq. in., and made up of rods of  $\frac{5}{8}$  inch diameter, the spacing will be  $12 \times 0.307 \div 0.54 = 6.8$  inches. To make the bond stress 80 lb. sq. in.,  $d = 2875 \times 6.8 \div (1.964 \times \frac{7}{8} \times 12 \times 80) = 11.8$  inches. So the thickness at the top of the footing is, with the covering outside the rods, 14 inches instead of 11.5 inches required by the bending moment. As the shear varies directly with the depth of earth, the spacing is increased accordingly. At a third of the height of the wall above the footing the spacing is  $6.8 \times 1.5 = 10.2$  inches. As the temperature stresses increase toward the top the spacing for the upper two-thirds of the height may be kept uniform. The slab may be of uniform thickness if the saving in expense of forms will be more than the cost of the added concrete. In this design the top will be made 10 inches and the batter on the back will be uniform. At the supports the bending moment is negative and numerically equal to the positive moment at the middle of the span. The moment



is negative for about one-fifth of the span on each side of the counterfort, and the outer reinforcement may be bent inward to carry it. The expense of bending the rods and fixing them in position is sometimes more than that of providing other rods of similar size and spacing over the counterforts. The latter method will be adopted in this problem.

As the unit shear does not exceed 40 pounds per square inch no diagonal reinforcement is required.

**The Footing.** The length of the outer cantilever will be assumed to be 3 feet. The weight of the vertical slab is  $\frac{1}{2}(10 + 14) \times 23 \times 150 \div 12 = 3450$  pounds. The prism of earth with the  $1\frac{1}{2}$  to 1 slope weighs  $\frac{2}{3}(7.33 + 7.66) 100 + \frac{1}{2} \times 7.66 \times 5.1 \times 100 = 19,210$  pounds, and the footing, if 2 feet thick, weighs  $11.5 \times 2 \times 150 = 3450$  pounds. The center of gravity of these forces is found to be 6.92 feet from *E* (Fig. 65). The horizontal pressure per foot of length of the earth backing is  $P = \frac{1}{2} \times 25 \times 25 \times 25 = 7812$  pounds applied 8.33 feet above the base. From similar triangles, the resultant force is found to pierce the base 0.6 feet inside the middle third of the length, or 1.32 feet from the middle, so the assumption as to the length of base was correct if the allowable pressure on the ground be not exceeded. The pressure on the earth at *E*, Fig. 65, is

$$\frac{26110}{11.5} + \frac{6 \times 1.32 \times 26110}{11.5 \times 11.5} = 3830 \text{ pounds}$$

and, at *D*, 710 pounds per square foot. This is well within the assumed bearing power of the earth under the footing.

The weight of the wall and of the prism of earth is, for assumed dimensions, 26,100 pounds. The horizontal pressure is 7812 pounds or 0.30 of the weight. To prevent sliding the coefficient of friction should be considerably more than 0.30. Usually the footing is in a trench dug for the purpose and sliding can only take place when the wall is forced into this solid bank of earth. If the wall be built on top of ground, the covering of the footing to be done later, projections into the earth under the footing are provided. This projection may be at the rear extremity of the footing and may be used to lengthen the grip of the tension rods in the counterforts, or it may be built where the ground is most solid, or under the center of gravity of the loads. In this problem it is assumed that no such projection is needed to prevent sliding.

**The Outer Cantilever.** The reinforcement may be assumed upon the basis of  $p = 0.005$  for the depth of 2 feet. If  $\frac{7}{8}$  inch rods be used the spacing will be  $0.6013 \div (22 \times 0.005) = 5.5$  inches. The depth, as determined by the bond, will be  $d = V \div 70 mo = (3830 + 2990) \cdot 1.5 \div 70 \times 2.75 \times 2.2 = 24.2$  inches to the middle of the steel. For shear,  $d = 10,230 \div (12 \times 35) = 24.4$  inches. For sufficient bending strength  $d^2 = M \div N_1Cb$ . The center of moments will be taken under the middle of the vertical wall as in the previous problem. The upward pressure increases from 2820 pounds under the wall to 3830 at the outer end, and the lever arm of the resultant is found to be  $3.6 (2820 + 3830 \times 2) \div 3 (2820 + 3830) = 1.89$  feet. Using Plate I,  $d^2 = 3325 \times 3.6 \times 1.89 \div (0.144 \times 500) = 315$  square inches, and  $d = 17.8$  inches to the center of the steel. Hence, the thickness at the vertical wall will be taken as the greatest of these three determinations, or  $24.4 + 2.5 = 26.9$  inches. At the outer extremity the thickness may be reduced to 12 inches. It is well to avoid sharp reentrant angles on either side of the vertical slab, and the forms may be so built as to avoid them without much extra expense. The rods will not be stressed to their limit in tension, so the grip will be sufficient if they are not formed into books in front, while more than 25 diameters are available in the rear.

**The Inner Floor Slab.** In this type the inner slab is a continuous beam partially fixed at the counterforts which form the supports. In the design of the outer cantilever the slight downward pressure of the covering of earth was neglected, but here the resultant of the upward and downward forces must be considered. As the former pressure decreases and the latter increases with the distance from the vertical slab, the resultant is maximum at the inner extremity of the footing and so a strip one foot wide at that point will be considered.

The average upward pressure on this strip is 845 lb. linear in., the average depth of earth over the back of the footing is 26.1 feet and the corresponding weight of a prism of a square foot of horizontal section is 2610 pounds. To this is added the weight of 2 cubic feet of masonry forming the footing, so the uniform load on the beam is  $2610 + 300 - 845 = 2065$  pounds per linear foot of beam 12 inches wide. The length of the beam will be taken as the distance between the middle of the counter-

forts or ten feet.  $M = \frac{1}{10} \times 2065 \times 100 \times 12 = 247,800 = N_1 \times 500 \times 12 d^2$ , and  $N_1 d^2 = 41.7$  square inches. If  $p = 0.005$ ,  $N_1 = 0.144$ , and  $d = 17.0$  inches to the middle of the steel. The shear at the edge of the counterfort, assuming the latter to have a width of 16 inches, is 8920 pounds, and  $d = 8920 \div (12 \times 35) = 21.3$  inches. For bond stresses of 80 pounds per square inch on  $\frac{7}{8}$  inch round rods spaced 5 inch c. to c. the depth is  $8920 \div (80 \times 2.4 \times 2.75) = 17.0$  inches. The depth at the counterfort will, hence, be  $21.3 + 2.5 = 23.8$  inches as required for proper shearing stress. This depth might be reduced to 20.5 inches at places where the shear is sufficiently decreased, but sometimes the saving of concrete does not equal the increased price of construction, and the depth will be made uniform. The spacing of the rods will be increased toward the vertical slab. At 3 feet from the end the shear is 5200 pounds, and the spacing is increased to  $5 \times 9035 \div 5200 = 8.5$  inches; at 4 feet from the end the shear is 4800 pounds and the spacing is 10.7 inches.

The bending moment is negative at the supports and reinforcement equal to that on the under side is inserted at the top and extended  $\frac{1}{2}$  of the clear span on each side of the counterfort.

**The Counterfort.** The vertical slab is kept in an upright position by the counterforts which may be considered as cantilever beams, fixed to the footing, and supporting the horizontal pressure of the earth backing. Each counterfort will then carry the load against 10 feet of wall, and the bending moment resulting is 5,926,000 lb. in. The depth of the beam on a line through the vertical slab at the top of the footing and perpendicular to the back edge of the counterfort is 90 inches to the reinforcement. Then from Plate I,  $5,926,000 = 0.144 \times 500 \times b \times 8100$  and  $b = 10.2$  inches. Then  $A = 0.005 \times 90 \times 10.2 = 5.6$  sq. in. This area will be supplied by five  $1\frac{3}{8}$  inch round rods, and the thickness of the counterfort must be  $3 + 2.5 \times 4 \times 1.2 = 15$  inches. At 15 feet below the top the bending moment is  $50 \times 15^3 = 168,750$  lb. in., and, at a point 8 feet higher, the moment is  $50 \times 7^3 = 17,150$  lb. in. The effective depths of the counterfort at these points are 56 and 26 inches respectively, and  $N_1 \div r$  may be found. At 15 feet below the top  $N_1 \div r = 0.0021$ , and, by trial in Plate I,  $p$  is found to be 0.0023, which corresponds to a steel cross-section of  $16 \times 56 \times 0.0022 = 2.06$



square inches. Two of the  $1\frac{3}{8}$  inch rods will be sufficient, and these will be continued to the top.

As the concrete is assumed to be incapable of supporting tensile stresses the counterfort must be bonded to the vertical and footing slabs by reinforcing rods. The force tending to part the slabs and the counterfort is the shear along the horizontal and vertical edges of the latter. At the top of the footing the shear on one foot in height is  $25 \times 23 \times 8.75 = 5050$  pounds. If half-inch round rods be used the number in 12 inches of height of wall will be  $5050 \div (0.196 \times 16,000) = 1.6$ . These rods are inserted in pairs, each hooked around the outer horizontal reinforcing bars and extending back 50 diameters into the counterfort. The spacing of these pairs at the footing will be  $12 \div 0.8 = 15$  inches. At 20 feet below the top the shear on 12 inches of height is 4375 pounds; at 15 feet, 3300 pounds; at 10 feet, 2200 pounds, and at 5 feet, 1100 pounds. The spacing of the pairs of bonding rods between these limits will accordingly be 17, 22, and 34 inches. The arrangement of the twelve pairs of rods is shown in Fig. 69.

In a similar manner the necessary bond between the counterfort and the footing slab is determined. At *D*, Fig. 65, the downward tension on the counterfort caused by the shear on both sides is 17,840 pounds on 12 inches of the length *DE*. On the succeeding spaces 12 inches wide the tension is decreased 2960 pounds per foot. At the extremity the tension is taken by the diagonal rods which are carried to the under side of the slab and there bent toward the front. The tension at  $2\frac{1}{2}$  feet from *D* is 11,900 pounds and two  $\frac{3}{4}$ -inch round rods are provided. They extend upward to the batter of the counterfort and downward to hook around the lower reinforcement of the slab. At  $4\frac{1}{2}$  feet from *D* the tension is 5980, and two  $\frac{5}{8}$  inch rounds are sufficient. At  $6\frac{1}{2}$  feet from the end one  $\frac{1}{2}$  inch rod is inserted and secured as just described.

**The Reinforcement.** The rods parallel to the batter of the counterfort are bent over to form hooks at the upper ends, and, at the lower ends, they may be bent into a horizontal position by a curve toward the front. In some designs sufficient anchorage is secured by extending the footing and the rods downward without bending the latter into hooks. In most walls of this type the length to be reinforced is greater than

that of the rods, and the latter must be overlapped in order that the tension may be continuous. If the beam be continuous and separate rods are provided for the negative moment the rods may be joined where they are not in tension and no overlapping is required. If the same rods be bent up to take the negative moment the splicing may best be arranged near the points of inflection.

In most designs there is sufficient length of grip to keep the bond stresses within proper limits even without hooked ends if the estimated load be not exceeded. In case of failure due to unforeseen loads the hooks serve to render collapse less sudden, although they may be entirely inert under working loads and ordinary conditions.

*Sequence of Work in Design of a Counterfort Retaining Wall*

**General Instructions.** Size of drawing sheet, 22"  $\times$  30"; border, 20"  $\times$  28".

Scale of drawing, 1 inch = 4 feet.

Drawing covers two counterforts and included bay. Plan is in lower left hand corner, section is above it. Rear elevation in upper right hand corner. The title, data, and bill of materials are in the lower right hand corner. Show sizes of all reinforcing steel and indicate the location of bends and hooks.

**Data.** Gravel foundation capable of sustaining 5 tons per square foot. Earth filling back of wall having surcharge of slope of 1.5 to 1. The horizontal pressure of earth is taken as 25 pounds per square foot at the top and increasing directly as the depth. The weight of filling is 100, and of the concrete 150 pounds per cubic foot. The allowable stresses are  $S_t = 16,000$ ,  $C = 500$ ,  $u = 80$ , and  $v = 40$ , all in lb. per sq. in. The value of  $\mu$  is 15.

The height of the wall is — feet, and the counterforts are spaced — center to center.

**Design.** (1) For trial assume the base as  $0.45 h$ . Assume the thickness of the footing as 24 inches for heights not over 25 feet.

(2) **The Vertical Wall.** Compute the thickness of a horizontal strip of the vertical slab 12 inches high at the top of the footing, also at  $\frac{2}{3}$  and at  $\frac{1}{3}$  of the depth. The vertical slab is

considered as a continuous beam supported by the counterforts. The positive and negative bending moments are each  $\frac{1}{10} wl^2$ . The front of the wall is vertical and the minimum allowable thickness at the top is 10 inches. Make a coping extending 4 inches in front and 12 inches deep.

Compute the shearing and bond stresses at the supports and change the thickness as computed for bending if necessary. Use  $u = V/moj$  and  $V = 35 bd$ . If diagonal tension anywhere exceeds 40 lb. sq. in. insert diagonal reinforcement. Provide reinforcement for negative moments at the supports.

Compute the spacing of the horizontal reinforcement.

**The Footing.** Assume the length of the outer footing from  $\frac{1}{4}$  to  $\frac{1}{3}$ , the assumed length of the base. Compute the weights and positions of centers of gravity of the prism of earth above the back footing, of the vertical wall and of the footing. Combine these weights and the horizontal pressure of the earth and find where the resultant pierces the base. This point should be within the middle third, otherwise the length of the base must be changed. Draw the pressure diagram and see that the allowable pressure on the ground be not exceeded.

Test the foundation for safety against sliding.

**The Outer Cantilever.** Assume the reinforcement to be 0.005 of the vertical cross-section and made up of small rods. Neglect the downward pressure of the earth and of the slab itself and find, from the pressure diagram, the upward bending moment and the vertical shear. Compute the thickness of the cantilever for bending, for shear, and for bond stresses.

**The Inner Slab.** Find, from the pressure diagram, the bending moment and the shear on the inner edge of the slab, taking a strip 12 inches wide. Compute the thickness according to bending, shear, and bond. Adopt the largest of these results as the depth. Make the depth uniform and vary the reinforcement according to the stresses.

**The Counterforts.** Consider the counterfort as a cantilever beam having an assumed width of — inches and a depth equal the perpendicular distance from the front of the vertical wall to the batter of the rear of the counterfort. Compute the reinforcement necessary along the sloping edge of the counterfort, considering the bending moment to be  $50 h^3$ , at the base, at  $\frac{2}{3} h$ , and at  $\frac{1}{3} h$ . Use the shear on both sides of the counter-



fort as loads producing tension between it and the horizontal and vertical slabs and determine the bonding reinforcement necessary.

**The Reinforcement.** Provide, in every case, a length of grip such that the bond strength beyond any section equals the tensile stress in the section; or  $AS_t = moux$ . If  $S_t$  be 16,000 lb. sq. in.,  $x$  is about 50 diameters.

Provide, over the supports, sufficient reinforcement to carry the negative stresses. Extend this reinforcement  $\frac{1}{2}$  of the clear span on each side of the counterforts.

The tension rods at the back of the counterfort are anchored by being bent into the horizontal at the bottom of the footing. The upper ends are bent into hooks. The other rods in the counterfort are hooked around the horizontal reinforcing rods in the footing and vertical slabs and extend straight inward or upward.

**Bill of Material.** Make a complete list of material needed for one bay, including the cement, sand, gravel, and broken stone; length and diameters of reinforcing rods; lumber for forms; amount of excavation and labor.

**Estimate of Cost.** Make an estimate of the cost of a bay of the wall, using the following prices: cement, at — per bbl.; sand, — cu. yd.; gravel, — per cu. yd.; broken stone, — cu. yd.; lumber, at — per M; labor, at — per day; superintendence, at —; depreciation and interest —.

## THE ALGEBRAIC INVESTIGATION OF AN ARCH

An arch is somewhat like the upper chord of a truss in that it may be entirely in compression, the tension chord being supplied by the earth between the abutments. If the abutments be free to move they are pressed outward by the thrust of the arch, the lower chord is broken, and the arch may fail precisely as a truss would fail under similar circumstances. Under this conception, the arch is more like a truss than like a beam, but most of the points of difference are more apparent than real.

**Types.** Stone arches may be built of blocks resting one upon another without cementing material between them, and devoid of tensile strength as a whole. Arches of concrete masonry may be built to act in like manner, but a monolithic

construction is more common. Again, the arch may be considered as stable only by gravity action, or as somewhat elastic and capable of regaining its original shape after the loading

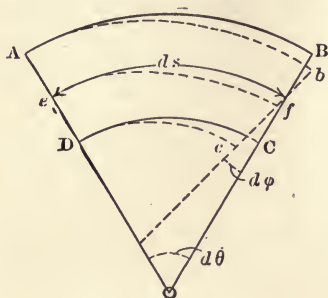

FIG. 70.

has been removed. With steel reinforcement inserted near the intrados and extrados, the arch ring is capable of taking tension or compression at the outer edges, and a method of analysis of stresses which takes into account the elasticity of the material is usually adopted. Some tests on arches show that, even for the voussoir type, the elastic theory

gives the best indication of the stresses resulting from the loads.

**Analysis.** Let  $ABCD$  in Fig. 70 be an elementary length of an arch ring, and  $\delta\theta$  the angle between the radial sections at the ends. If the result along the arch ring be applied otherwise than at the gravity axis,  $ef$ , the angle  $\delta\theta$  changes by  $\delta\phi$ , being made larger or smaller according as the point of application of the pressure is below or above the axis. As the radius of curvature is large in comparison

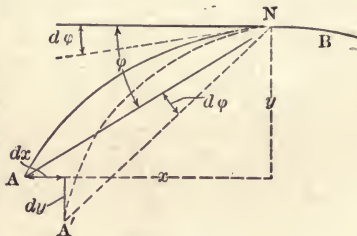

FIG. 71.

with depth of the arch ring,  $bB$  and  $cC$  may, without material error, be considered equal. Under the application of this thrust the deformation at a point distant  $z$  from the gravity axis is  $z \delta\phi$ . Or if  $z$  be  $fb = c$  the corresponding stress is, from the usual formula for deformation,  $\lambda = Pl/AE$ , and if  $C$  be the unit stress,

$$C = \frac{c\delta\phi E}{\delta s}$$

but from

$$M = CI/c$$

$$C = Mc/I = c\delta\phi E/\delta s$$

from which

$$\delta\phi = M\delta s/EI$$

and

$$M = EI \frac{\delta\phi}{\delta s}$$

In Fig. 71  $AB$  is the position of the gravity axis of the arch

ring before the loads are applied. If it be free to move, there is a tendency for  $A$  to take the position  $A'$  under the action of loads between  $A$  and any point as  $N$ . The distance  $AA'$  is  $AN \delta\phi$ , and, from similar triangles,  $\delta y: AN \delta\phi = x: AN$ ; also,  $\delta x: AN \delta\phi = y: AN$ , or

$$\begin{aligned} & \delta x = y \delta\phi \text{ and } \delta y = x \delta\phi \\ \text{but, as above,} & \delta\phi = M \delta s / EI \\ \text{so} & \delta x = My \delta s / EI \\ \text{and} & \delta y = Mx \delta s / EI. \end{aligned}$$

If the integration be extended over the length  $AB$ ,

$$\begin{aligned} \phi &= \int_B^A M \frac{\delta s}{EI} \\ x &= \int_B^A My \frac{\delta s}{EI} \\ y &= \int_B^A Mx \frac{\delta s}{EI} \end{aligned}$$

While these formulas are somewhat less strictly true for small finite lengths of arc,  $s$ , than for infinitesimal lengths,  $\delta s$ , no material error results if the fraction  $\delta s / I$  be considered a constant when the finite lengths,  $s$ , vary as  $I$  for all sections between  $A$  and  $B$ . Then,  $E$  being constant,

$$\Sigma \phi = s / EI \Sigma_B^A M \quad (126)$$

$$\Sigma x = s / EI \Sigma_B^A My \quad (127)$$

$$\Sigma y = s / EI \Sigma_B^A Mx \quad (128)$$

These are the three fundamental equations for arch analysis. The three additional equations may be written from the conditions of equilibrium:

$$\text{The algebraic sum of the horizontal forces} = \text{zero}, \quad (129)$$

$$\text{The algebraic sum of the vertical forces} = \text{zero}, \quad (130)$$

$$\text{The algebraic sum of the moments at any point} = \text{zero}. \quad (131)$$

These six equations are sufficient for the solution of arches of the three types in common use.

Arches are built having (a) hinges at each support, and at the crown; (b) hinges at the supports only; and (c) hingeless.



**The Three-hinged Arch.** (a) In Fig. 72 the resultant of any load,  $P$ , on a three-hinged arch must pass through definite points at  $A$ ,  $C$ , and  $B$  on the arch axis, and, there being no

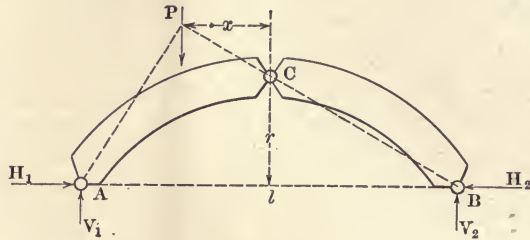

FIG. 72.

eccentricity of the point of application, there can be no moments at these points. Then, taking the moments about  $B$ ,  $A$ , and  $C$ ,

$$V_1 l - P(l/2 + x) = 0$$

$$V_2 l - P(l/2 - x) = 0$$

$$H_1 r + Px - V_1 l/2 = 0$$

$$V_1 + V_2 - P = 0$$

$$H_1 - H_2 = 0.$$

If the loads be inclined, the same equations result if horizontal and vertical components be used instead of  $P$ . With the horizontal and vertical components of the reactions and

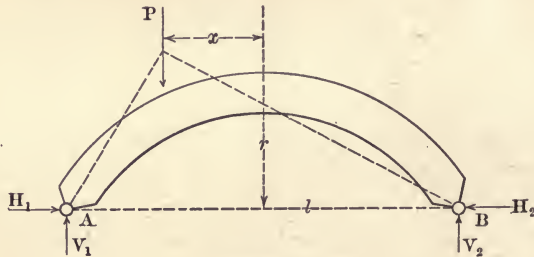

FIG. 73.

the points of application known, the shear and the bending moments may be readily determined at any point.

**The Two-hinged Arch.** (b) In Fig. 73 the two-hinged arch is free to rotate at  $A$  and  $B$ , but is otherwise fixed at these points. Hence, equations (127) and (128) become

$$\sum_B^A My = 0 \text{ and } \sum_B^A Mx = 0$$

also

$$\begin{aligned} H_1 - H_2 &= 0 \\ V_1 l - P(l/2 + x) &= 0 \\ V_1 + V_2 - P &= 0 \end{aligned}$$

These equations, modified as in (a) for inclined loads, may be solved for  $H_1$ ,  $H_2$ ,  $V_1$ , and  $V_2$ , after which the moment, thrust, and shear at any section may be found.

**The Hingeless Arch.** (c) In the hingeless arch, Fig. 74, the points of application of the resultant on the right or on the

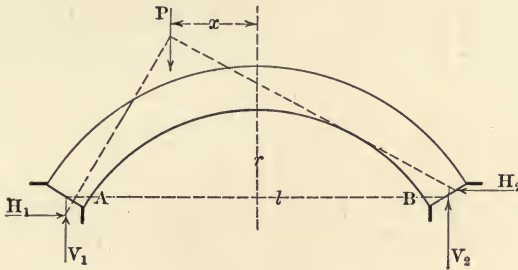

FIG. 74.

left are unknown, and there are usually bending moments,  $M_2$  and  $M_1$  at these points. There are then, at each support, three unknown quantities, or six in all,  $M_1$ ,  $M_2$ ,  $H_1$ ,  $H_2$ ,  $V_1$ , and  $V_2$ , to be found and all of equations (126)–(131) are needed. Since the arch is fixed at  $A$  and  $B$  there is no change in the direction of the tangent to the curve of the gravity axis of the arch ring at these points, so (126) becomes zero. Also, according to definition,  $A$  and  $B$  do not change relatively as to height or distance apart, so (127) and (128) also become zero. In the above formulas  $M$  represents the resisting moment in the arch ring, and, to be of use in the analysis or stresses, must be expressed in terms of the moments of the loads.

In Fig. 75 the arch ring is separated at the crown and the forces are replaced by their resultant,  $T_c$ , which is resolved into components,  $H_c$  and  $V_c$ . For the right half of the arch the moment at the crown,  $M_c$ , is positive when  $T_c$  is applied above the gravity axis, and  $V_c$  is positive when  $T_c$  is inclined upward as shown, otherwise  $M_c$  and  $V_c$  are negative. If  $m_r$  be the moment of loads between the crown and any point,  $xy$ ,

on the right of the crown,  $M_r$ , the resulting moment at that point, and  $M_c$ , the bending moment at the crown  $H_c e$

$$M_r = M_c + m_r + H_c y \neq V_c x \quad (132)$$

and 
$$M_l = M_c + m_l + H_c y = V_c x \quad (133)$$

The signs of all moments producing compression in the upper fibers of the arch ring are positive, and each half of the arch is considered as a cantilever beam. Hence  $m$  is always negative,  $M_c$  has like signs, and  $V_c$  opposite signs on the right and left sides of the crown.

Since in Fig. 71  $A$  is any point on the gravity axis of the arch, it may be taken at the crown and the limits of the summations in (126), (127), and (128) will be over half the arch. Then

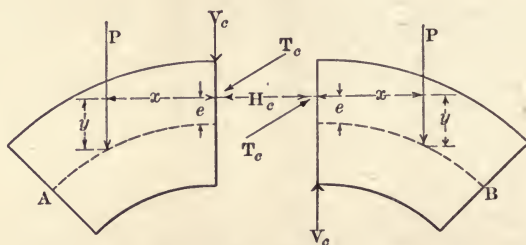

FIG. 75.

the summation on either side of the side of the crown will be numerically equal in (126) and (127), but with opposite signs.

Letting  $M_l$  and  $M_r$  indicate  $\sum_C^A M$  and  $\sum_C^B M$  respectively in Fig. 74, there may be written from (126), (127), and (128),

$$\sum M_l = - \sum M_r \quad (134)$$

$$\sum M_l y = - \sum M_r y \quad (135)$$

$$\sum M_l x = \sum M_r x \quad (136)$$

The above summations are obtained as follows: the arch ring is divided into parts such that  $s/I$  is constant, and the load and point of application of the same are computed for each division. The moments of all forces between each load and the crown are computed about the point of application of each load, and the results are added.

After substituting the values given in (132) and (133) the following equations result:



$$2 n M_c + 2 H_c \Sigma y + \Sigma m_l + \Sigma m_r = 0 \quad (137)$$

$$2 M_c \Sigma y + 2 H_c \Sigma y^2 + \Sigma m_l y + \Sigma m_r y = 0 \quad (138)$$

$$2 V_c \Sigma x^2 + \Sigma m_l x - \Sigma m_r x = 0. \quad (139)$$

The moment  $M_c$  is constant for a given loading, but in the summation it occurs once for each of the loads considered, and,  $n$  being the number of loads on each side of the crown,  $\Sigma M_c = n M_c$ .

From (139)

$$V_c = \frac{(\Sigma m_r - \Sigma m_l) x}{2 \Sigma x^2} \quad (140)$$

From (137) and (138)

$$H_c = \frac{n (\Sigma m_l y + \Sigma m_r y) - (\Sigma m_l + \Sigma m_r) \Sigma y}{2 [(\Sigma y)^2 - n \Sigma y^2]} = 0 \quad (141)$$

$$M_c = - \frac{\Sigma y (\Sigma m_l y + \Sigma m_r y) - (\Sigma m_l + \Sigma m_r) \Sigma y^2}{2 [(\Sigma y)^2 - n \Sigma y^2]} \quad (142)$$

These equations are sufficient for the computation of the stresses at any point in the arch ring when the loads and the points of application are known.

The distances  $x$  and  $y$  are measured from a scale drawing of the arch, and the moments of loads are readily computed algebraically, or they may be found graphically as will be shown below. For this purpose the equilibrium polygon will be so drawn as to be available for the algebraic as well as for the graphic method of solution, and it need not be repeated. (See page 194).

**Stresses at any Section.** After the numerical values of  $V_c$ ,  $H_c$ , and  $M_c$  have been found, the resultant pressure,  $T$ , at any section is best found from the force polygon. The component of  $T$  in the direction of the radial section is the shear, and that normal to the section is the thrust at that section. Then the bending moment at any section is given by formulas (132) and (133).

Having the bending moments given, the stresses in a reinforced concrete arch ring are obtained by applying the principles on pages 90 to 100.

**Stresses Due to Temperature.** A rise or fall in temperature tends to cause a change in the length of the span of an arch. As the arch proper is much more susceptible to such changes

than is the earth or rock upon which the abutments rest, there will be a relative as well as an absolute change in the lengths of span of the arch and of that between the abutments. In the analysis of stresses it may be assumed that the distance

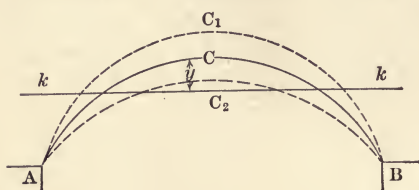

FIG. 76.

between the abutments remains constant. In an arch with hinges the temperature stresses are nearly zero, as the curve is free to change direction at two or three points, but in the hingeless type, the curve assumes the dotted positions in Fig. 76 only by resisting bending at A and B, and creating stresses along the entire curve. If  $e$  be the coefficient of expansion of concrete,  $t$  the change in temperature from the normal, and  $l$  the span, the change in length of the span will be, if not resisted,  $tel$ . This is  $\Sigma x$  in (127). Since there can be no change in the direction of the tangents at A and B, (126) is zero. Hence,

$$2 \sum_C^A M y \frac{s}{EI} = tel$$

and

$$2 \sum_C^A M \frac{s}{EI} = 0$$

Also, since no external loads are considered and the arch is symmetrical,  $m$  and  $V$  are zero, and on either side of the crown

$$M = M_c + H_c y \quad (143)$$

combining these three equations,

$$2 s/EI (M_c \Sigma y + H_c \Sigma y^2) = tel$$

and

$$n M_c + H_c \Sigma y = 0,$$

from which

$$H_c = \pm \frac{ntel}{2[n \Sigma y^2 - (\Sigma y)^2]} \frac{IE}{s} \quad (144)$$

and

$$M_c = - \frac{H_c \Sigma y}{n} \quad (145)$$

also

$$M = M_c + H_c y. \quad (146)$$

The thrust acts along the line  $kk$ , Fig. 76, which is  $\Sigma y \div n$  below the crown, and forms the closing line of the equilibrium polygon. The shear and normal pressure on any section are

found by the resolution of  $H$ , as was done with  $R$  in the discussion of external loads.

The positive sign in (144) is used when  $t$  indicates a rise in temperature and the negative sign when the change is downward.

The dimensions of the arch are usually in feet, and so  $E$  is in pounds per square foot, or about  $2,000,000 \times 144$ .

The bending moment at any point is  $M_c + H_c y$ , and if the above value of  $M_c$  be known, the bending moment at any point is given by the product of  $H$  and the distance of the point from  $kk$ . Hence it is seen that,  $H_c$  being positive, all moments above the line  $kk$  are negative, and all moments below  $kk$  are positive. For a fall in temperature,  $H_c$  is negative and the signs of the moments are reversed.

**Effect of Arch Ring Shortening due to Thrust.** The compression caused by the thrust along the arch ring would, if not resisted, make the arc shorter, and it has an effect similar to that due to a fall in temperature. The change in length of span  $l$ , due to an average stress  $C$ , in the concrete is  $Cl/E$ , which corresponds to  $tel$ , the change in length due to temperature variation, or,

$$H = -\frac{ncl}{2[n \sum y^2 - (\sum y)^2]} \frac{I}{s} \quad (147)$$

$$\text{At the crown} \quad M_c = -\frac{H_c \sum y}{n} \quad (148)$$

$$\text{and in general} \quad M = M_c + H_c y. \quad (149)$$

With the thrust and moment given, the eccentricity may be found and the stress in the concrete determined by the principles, pages 90-100.

The combination of stresses will be given in the design of an arch, page 206.

## THE GRAPHIC ANALYSIS OF A HINGELESS ARCH

**Principles.** In Fig. 77,  $a_1, a_2 \dots a_n$ , is the gravity axis of the arch ring, and  $c_1, c_2 \dots c_n$  is the equilibrium polygon of  $n$  loads assumed to be drawn in proper position. Then the bending moment at any section, as  $a_3$ , is the product of the pole distance of the force polygon from which  $c_1, c_2 \dots c_n$  is



constructed, and of the intercept  $a_3c_3$ ; or  $M = H \cdot a_3c_3$ . Since  $H$  is constant for any given force polygon, the fundamental formulas, (134), (135), and (136) become

$$\Sigma ac = 0, \Sigma ac \cdot y = 0, \text{ and } \Sigma ac \cdot x = 0$$

the origin of coördinates being at the middle of the span, and  $xy$  coördinates of any point on the line  $a_1, a_3, a_n$ .

If the force polygon be drawn with the true pole distance, and the true equilibrium polygon be in position, the stresses in

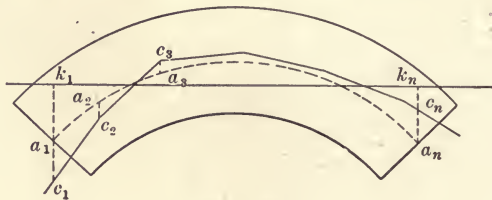

FIG. 77.

the arch ring may be found for any point. The problem then is to determine the true pole distance, and at least one point on the arch ring through which the true equilibrium polygon must pass.

For some system of symmetrical loading the line of pressure represented by the polygon  $c_1, c_2, c_n$  will fall, everywhere, on the gravity axis  $a_1, a_2, a_n$ . The pressure at the ends of the span,  $a_1, a_n$ , cause reactions at these points which may be resolved into vertical and horizontal forces. The closing line of the polygon will then be  $a_1, k_1, k_n, a_n$ , and the position of  $k_1, k_n$  is to be determined.

In Fig. 77 let  $ak$  and  $ck$  represent the intercepts between the line  $k_1k_n$  and the curve  $a_1a_n$ , and polygon  $c_1c_n$  respectively,

then

$$ac = ck - ak$$

$$\text{from above formulas, } \Sigma ac = \Sigma ck - \Sigma ak = 0 \quad (150)$$

$$\Sigma ck \cdot x - \Sigma ak \cdot x = 0 \quad (151)$$

$$\Sigma ck \cdot y - \Sigma ak \cdot y = 0 \quad (152)$$

The position of the curve  $a_1, a_2 \dots a_n$  is already determined and (151) and (150) are satisfied if  $\Sigma ak$  and  $\Sigma ak \cdot x$  are each zero. The last formula (152) is satisfied only when  $c_1 \dots c_n$

is drawn from a force polygon having the true pole distance, as will be shown later.

**Locating  $k'k'$ .** In Fig. 78  $\Sigma c'k'$  is zero and equation (150) is satisfied when  $k'k'$  is so drawn that  $c'_1k'p' + c'_nk'p' = p'bp'$ , or, otherwise, when the area of the trapezoid  $c'_1k'k'c'_n$  equals the area of the segment  $c_1bc_n$ . One of an infinite number of positions of  $k'k'$  then satisfies the first condition when  $o'k'$  is the mean ordinate of  $c'_1bc'_n$  and  $o'c'_1 = o'c'_n$ .

The second equation (151) is satisfied when  $\Sigma ak \cdot x = \Sigma ck \cdot x = 0$ , or, in other words, when the center of gravity of the trapezoid  $c'_1k'c'_n$  is on the vertical line through the center of gravity

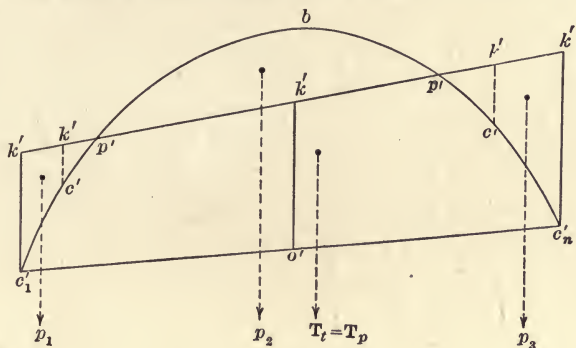

FIG. 78.

of the equilibrium polygon  $c'_1bc'_n$ . This may be readily shown. Let  $c'_1k'p'$ ,  $bp'p'$ , and  $p'k'c'_n$  be represented by  $p_1, p_2$  and  $p_3$ , and let the centers of these areas, or forces, be at  $x_1, x_2, x_3$  from the origin of coördinates. Also, let  $T_t$  and  $T_p$  be the areas of the trapezoid and the equilibrium polygon respectively, with centers of gravity  $x_t$  and  $x_p$  from the origin. Then

$$T_t \bar{x}_t = T_p \bar{x}_p + (p_1 x_1 - p_2 x_2 + p_3 x_3)$$

$$= T_p \bar{x}_p + \Sigma c'k' \cdot x$$

or

$$T_t \bar{x}_t = T_p \bar{x}_p$$

and

$$x_t = x_p$$

since

$$\Sigma c'k' \cdot x = 0 \text{ and } T_t = T_p.$$

When the polygon  $c'_1bc'_n$  represents the gravity axis of a symmetrical arch,  $c'$  and  $k'$  become  $a$  and  $k$ , then  $a_1kkan$  becomes a rectangle, and  $kk$  is parallel to  $a_1an$ , Fig. 77, and at a distance above it equal to the mean ordinate of the segment  $a_1a_3a_n$  or to the area  $a_1a_3a_n \div a_1a_n$ .

When the gravity axis of the arch is in the form of a parabola the distance  $a_1k$  is  $\frac{2}{3}$  of the rise. If the curve of the gravity axis be a segment of a circle the distance  $a_1k = a_nk$  is given in the following table:

$R \div S$	$a_1k$	$R \div S$	$a_1k$	$R \div S$	$a_1k$	$R \div S$	$a_1k$	$R \div S$	$a_1k$	$R \div S$	$a_1k$
.05	.663	.10	.672	.15	.680	.20	.688	.25	.698	.30	.714
.06	.669	.11	.673	.16	.682	.21	.689	.26	.701	.40	.745
.07	.669	.12	.675	.17	.684	.22	.691	.27	.704	.50	.785
.08	.670	.13	.677	.18	.686	.23	.693	.28	.707	—	—
.09	.672	.14	.679	.19	.687	.24	.695	.29	.711	—	—

When the gravity axis is an irregular curve, as is usually the case, the height of  $kk$  above the line  $a_1a_n$  is determined by dividing the span into an even number of spaces, equidistant apart, having the crown in the middle of one of the spaces, and finding the mean of the ordinates at each division point. This is the usual method and it is essential that the sum of the ordinates multiplied by the length of a space does not differ materially from the area of the segment covered.

$$\text{TO MAKE } \Sigma ck \cdot y = \Sigma ak \cdot y$$

**The Trial Equilibrium Polygon.** In general, the pole distance is unknown, and after assuming a trial pole, a trial equilibrium polygon is drawn. From this trial polygon and the three formulas (150), (151), and (152), the true pole and the true equilibrium polygon are found.

In Fig. 79 (b), the loads are laid off to scale, and a trial pole is chosen opposite the point on the load line between the loads next to and on either side of the crown. The trial equilibrium polygon is then drawn as shown in (c). (In general the trial polygon may be drawn with any assumed pole, but for use in the algebraic solution, pages 187–189, the pole is here taken as indicated. If, then, the line through the two points mentioned be extended, the bending moments of any loads about the crown is given by the product of the intercept, between that line and the equilibrium polygon, and the pole distance.)

Having the equilibrium polygon completed, the span, Fig. 79 (c), is divided into an even number of equal spaces, often the same as that of the loads, one of the spaces being bisected



by the middle of the span. The mean of the ordinates is laid off at the middle and the point  $o'$  is thus located. If any line  $k'k'$  be drawn through  $o'$ , and verticals through  $c'$  and  $c'_n$ , the areas  $c'k'k'c'_n$  and  $c'_1c'_9c'_n$  are equal, or  $\Sigma c'k' = 0$ . If, in addition, the center of gravity of the trapezoid be on that

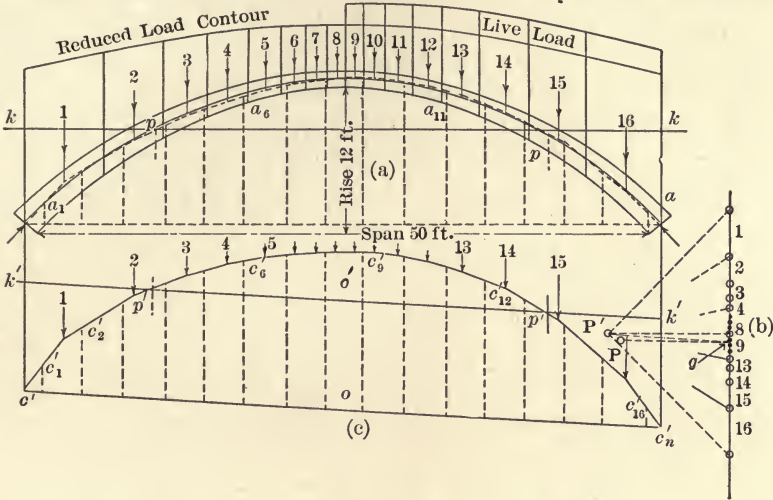

FIG. 79.

through that of the segment,  $\Sigma c'k' \cdot x$  is zero. The problem, then, is to so proportion  $c'k'$  and  $c'_nk'$  that the center of gravity of the trapezoid falls at the proper distance from  $c'$ . In any trapezoid, as that in Fig. 80, the center of gravity is located by the equations

$$x = h \frac{b + 2c}{3(b + c)} \quad x_1 = h \frac{2b + c}{3(b + c)} \quad \text{and} \quad y = \frac{ab + b^2}{3(b + c)} + \frac{a + c}{3}$$

From these equations it may be shown that, if  $e = l/2 - x$ ,  $c = (b + c)(l + 6e) \div 2l$ , and  $b = (b + c)(l - 6e) \div 2l$ . In the problem now being considered  $e$  is the distance from the center of gravity of the segment enclosed by trial equilibrium polygon to the middle of the span,  $b$  is  $c'k'$  if  $e$  be on the

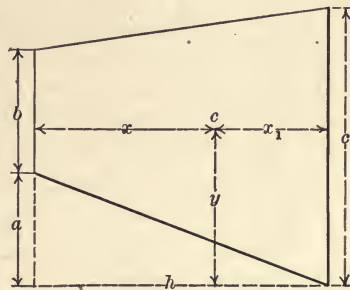

FIG. 80.

right of the middle of the span, otherwise  $b$  is  $c'_nk'$  and  $c$  is  $c'k'$ .

That is, the larger of  $c'k'$  and  $c'_nk'$  is on the same side of the middle of the span as is  $e$ . Then

$$c'k' = \frac{l - 6e}{l} oo' \text{ and } c'_nk' = \frac{l + 6e}{l} oo'$$

and  $k'k'$  may be correctly located.

The distance  $e$  is easily computed from the ordinates at the division points. The differences in the lengths of ordinates at like distances from the middle of the span are multiplied by their distances from the middle, the products are then summed and divided by the sum of the ordinates. Then, in Fig. 79 (b),

$$e = [\frac{1}{2} (o_5 - o_4) + \frac{3}{2} (o_6 - o_3) + \frac{5}{2} (o_7 - o_2) + \frac{7}{2} (o_8 - o_1)] \div \Sigma o$$

The ordinates, as  $o_6$  are from  $a_6$  to  $c'c'_n$ .

This result gives  $e$  in terms of spaces. The verticals at  $c'$  and  $c'_n$  may now be laid off and  $k'k'$  may be drawn. It should be noticed that this construction refers to  $c'c'_6c'_n$  as a geometrical figure and not to the line of action of the loads themselves. The latter could be found by producing  $c'c'_1$  and  $c'_nc'_{n-1}$  to their intersection.

If the inflection points,  $p'$ , where the line  $k'k'$  crosses the trial equilibrium polygon, be projected up to  $kk$  in (a), two points through which the true equilibrium polygon must pass are located.

**The True Equilibrium Polygon.** If in Fig. 79 (b) a line be drawn through  $P'$ , parallel to  $k'k'$ , the force line will be divided into two parts representing the reactions of the loads at the supports. If a horizontal line be drawn through this point of division, and if  $P'$  be projected vertically upon it, a new pole  $P''$  will be found and a new equilibrium polygon may be drawn having  $k'k'$  horizontal.

If this polygon be drawn in (79) (a) through  $pp$ ,  $\Sigma ck$  will be equal to  $\Sigma M$  and  $\Sigma ck \cdot x$  will equal  $\Sigma M \cdot x$ , but, in general,  $\Sigma ck \cdot y$  will not equal  $\Sigma ak \cdot y$ . Since  $y'$ , in (c), varies as the pole distance, the true pole distance,  $H$ , may be found when  $\Sigma ak \cdot y$  and  $\Sigma ck \cdot y$  have been scaled and

$$\text{True pole distance: Trial pole distance: } : \Sigma ak \cdot y : \Sigma c'k' \cdot y'$$

With this new pole distance the true equilibrium polygon is drawn through  $pp$  in (a), and the three conditions:  $\Sigma M = 0$ ;  $\Sigma M \cdot x = 0$ , and  $\Sigma M \cdot y = 0$  are satisfied.

From this point the determination of the stresses are identical with the same work in the algebraic solution of the problem on pages 184-186.

**Temperature Stresses.** Since the stresses depend upon  $M_c$  and  $H_c$  the method given under the algebraic solution is used. It must be remembered that the values of  $y$  in the two methods differ by the rise of the arch, being measured downward from the crown in one case and upward from the middle of the span in the other. With this exception the same formulas apply in both methods.

**Stresses Due to Arch Ring Shortening.** The same remarks as made regarding temperature stresses apply to the determination of stresses of this character.

#### *Design of a Reinforced Concrete Elastic Arch Ring*

**Loads and Dimensions.** It is required to design, and compute the stresses in, a reinforced concrete arch ring of 50 feet clear span and of 12 feet rise, and having no hinges either at the crown or at the springing line. The load will be assumed as 150 pounds per square foot in addition to the dead load. This loading is suitable for rather heavy traffic, such as would exist on roads near large cities. In case more definite knowledge concerning the traffic to be carried is available, more exact loading may be used in the computations. As a live load is apt to be concentrated it is usual to assume heavier unit loading for short than for long spans. The loads which are carried to the arch ring by a spandrel filling of earth, are well distributed, and it is quite common to assume a supposed equivalent uniform load even when some heavy concentrated loads, such as a road roller, have to be carried. If the earth filling be shallow, a definite rolling live load should be imposed. Road rollers and traction engines may weigh 15 tons and an electric street railway car may have as much as 6 tons on an axle.<sup>1</sup> The level spandrel filling is taken as 3 feet deep at the crown.

The intrados is the arc of a circle and the depth, in inches, of the arch ring at the crown is computed from the formula<sup>2</sup>

$$t = \sqrt{s} + 0.1 s + 0.005 w_l + 0.0025 w_a$$

<sup>1</sup>For a discussion of moments due to street railway cars see article by the author in *Street Railway Journal*, April 11, 1903, page 252.

<sup>2</sup>*Engineering Record*, Nov. 4, 1905, p. 562.



in which  $s$  is the span in feet,  $w_e$  and  $w_l$  are the live load and dead load at the crown in pounds per square foot respectively. This is known as Weld's formula and, while it does not take into account the rise of the arch, is quite satisfactory for the purpose of preliminary design. Substituting the dimensions in this problem, the crown thickness is found to be 13.5 inches. The thickness at the springing is from two to three times that at the crown, or in this problem 26 inches. The thickness at the crown is taken, for trial, as 13.0 inches.

**The Curves for the Intrados and the Extrados.** When the arch is comparatively flat the segment of a circle is often used for both intrados and extrados with the result that the line of pressure will fall near the curve midway between them. A rather more graceful appearance is given if the radii be diminished near the abutments and the curve made to approach the form of an ellipse. The preliminary extrados is a smooth curve between points fixed by the thickness of the arch ring at the crown at the haunch and at the skewback. The curve midway between the intrados and extrados is the linear arch which, in the computations, is the presentative of the masonry ring. This curve is on the gravity axis of the arch.

**Making  $ds/I$  Constant.** The next step is to divide the arch ring so that  $dsi \div I$  is constant from the crown to the springing line. The moment of inertia here used is that of the concrete cross-section combined with that of the steel, or the transformed section as described in Chapter IV, page 90. The percentage of steel to be used varies with the ratio of live to dead load, being more for short than for long spans. In this problem the steel will be assumed as one per cent. of the cross-section at the crown, one half at 2 inches from the intrados, and half at the same distance from the extrados. Throughout the greater part of the arch ring the steel will be nearly 1/10 of the thickness of the concrete from the edge, and the diagrams in Chap. IV may be used.

In Fig. 82 the length  $CA$  is that of half the gravity axis of the arch while the curve is plotted by ordinates equal to the transformed moments of inertia at six places along the arch

ring. The value of  $I_c$  at the crown is  $\frac{1}{12} \times 12 \times 13^3 + 0.01 \times 15 \times 156 \times \frac{(13 - 4)^2}{2} = 2760 \text{ in.}^4 = 0.129 \text{ ft.}^4$ . The other

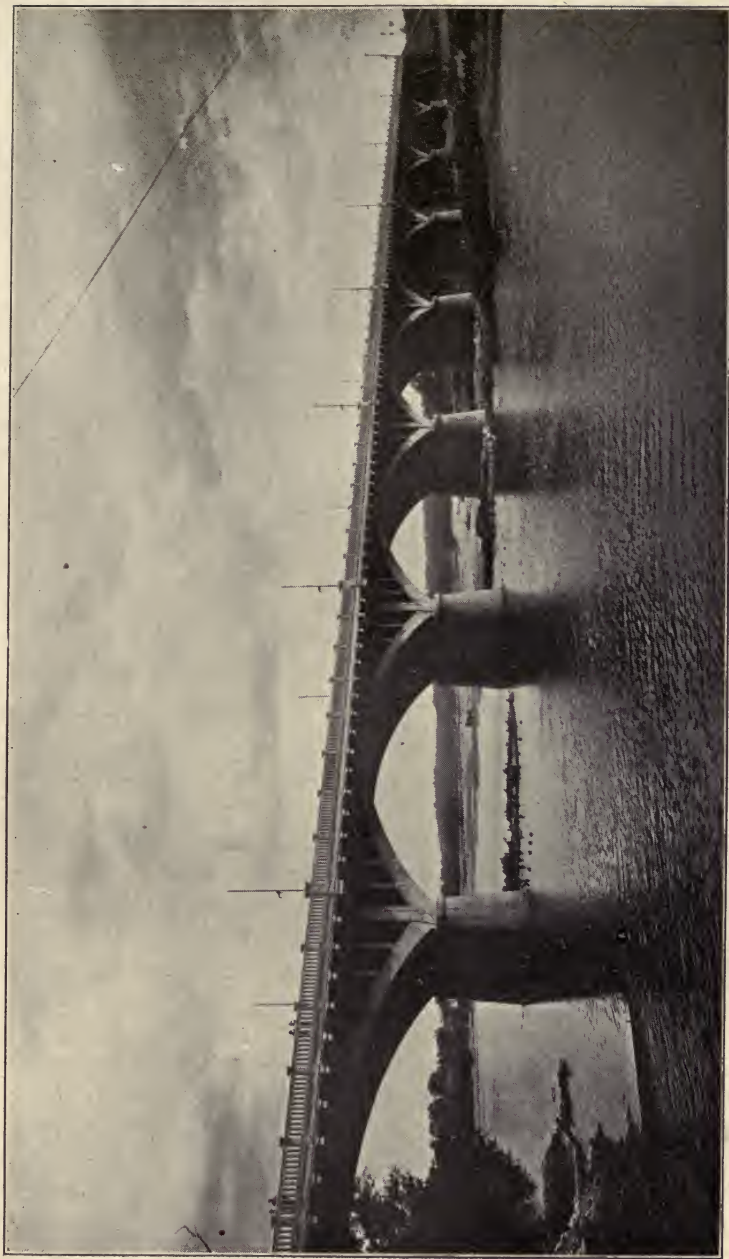

FIG. 81.

ordinates are found in like manner. The length  $CA$  is to be so divided into the various parts,  $ds$ , eight in this case, that each  $ds$  divided by the ordinate to its middle point will be constant. This is done by trial by finding  $I_a$ , the average of several ordinates, and the average  $ds$ , or  $CA \div 8$ . The length of the gravity axis of half the arch ring is found by scale to be 29.3 feet, so the average  $ds$  is  $29.3 \div 8 = 3.66$  feet. The average of the

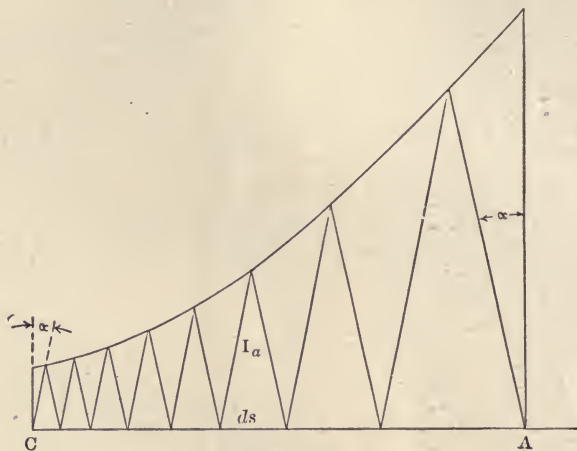

FIG. 82.

ordinates is found to be 0.488, so the tangent of the angle  $\alpha$  is  $ds \div 2 I_a$  or  $3.66 \div 0.976 = 3.8$ . This is only approximate since it is based upon ordinates spaced equidistant apart while, in the final division, most of the ordinates will be taken where the arch ring is thin. Assuming  $\tan \alpha$  somewhat over 4, and beginning at  $C$ , the triangles in Fig. 82 are drawn as shown. The final diagonal should pass through  $A$ , which result is accomplished by a few changes in the assumption of  $\tan \alpha$ . The intercepts on  $CA$  are scaled and laid off on the gravity axis as values of  $ds$ . The ordinates in Fig. 82 are plotted to a larger scale than is  $AC$  and  $\tan \alpha$  is determined by corresponding scales. The weight of the parts of the arch ring of length  $ds$  is combined, with that of the spandrel filling and live load over the horizontal projection of the same lengths, into a single load on each  $ds$ . At points where this load passes through the gravity axis of the arch ring the thickness of the ring is scaled and the transformed moment of inertia is computed. Then  $ds \div I_t$



should be constant. By scale the values of  $ds$  are found to be 1.44; 1.76; 2.05; 2.56; 3.16; 4.16; 5.65; and 8.52 feet respectively.

**The Reduced Load Contour.** For convenience in finding the points of application of the loads, the depths of equivalent spandrel and live loads of the same unit weight as the arch ring are found and plotted above the arch ring in Fig. 79. The center of gravity of a trapezoid is found graphically as shown in Fig. 83. The shorter segment of each diagonal, as  $Ao$  and  $Do$ , are laid off on the longer segments at  $c$  and  $b$ , and the center of gravity of the triangle  $obc$  is on that of the trapezoid. The spandrel filling is assumed to weigh 100 pounds per cubic foot or  $\frac{5}{7}$  that of the arch ring while the live load is that of a layer of masonry 12.9 inches deep. The contour for the reduced spandrel filling is, at all points, a distance above the extrados equal to  $\frac{5}{7}$  of the depth of the actual spandrel filling. The live load is assumed to cover half the span and the contour for this load is everywhere 12.9 inches above that for the spandrel filling.

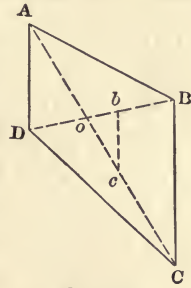

FIG. 83.

**The Load Diagram.** The load on any length  $ds$  is found by multiplying the area of the corresponding trapezoid, in square feet, by 140, the lower limit of the trapezoid being the intrados of the arch ring. In this manner the loads in pounds are found to be

No.	Load	Arm	No.	Load	Arm	No.	Load	Arm	No.	Load	Arm
1	8830	22.70	5	1275	6.51	9	850	0.72	13	2350	9.37
2	4580	17.11	6	1000	4.20	10	1060	2.32	14	3220	12.78
3	2660	12.79	7	800	2.32	11	1310	4.20	15	5300	17.09
4	1875	9.38	8	630	0.72	12	1650	6.51	16	9760	22.68

The arm in this table is the distance from each load to the middle of the span. Before drawing the force or equilibrium polygons it should be ascertained whether or not  $ds \div I$  is constant. To do this the thickness of the arch ring is scaled at each load and the transformed moment of inertia found. These moments, together with the values of  $ds$ , are given in the following table:

Load	$d_s$	$I_t$	Ratio	Load	$d_s$	$I_t$	Ratio
1	8.52	0.911	9.35	5	2.57	0.276	9.32
2	5.65	0.605	9.34	6	2.05	0.220	9.32
3	4.16	0.444	9.37	7	1.74	0.187	9.33
4	3.17	0.340	9.32	8	1.44	0.154	9.35

As both  $d_s$  and  $I_t$  are found by scale, and therefore subject to some error, the ratio is fairly exact.

**The Trial Equilibrium Polygon.** With the magnitude and position of each load known, the force and trial equilibrium polygons may be constructed. The pole distance is assumed at 20,000 pounds and the pole is opposite the point on the load line between the 8th and 9th loads. The loads are assumed to act vertically so the load line is straight as shown in (b). The equilibrium polygon is tangent to the line of resistance and hence for a continuous load, coincides with that curve only at the points of tangency. For this reason ordinates through the trial equilibrium polygon at points other than those just established under the loads should be used. In this problem the span of the trial equilibrium polygon, which is that of the gravity axis of the arch ring, is divided into 16 equal parts so that one part is bisected by the point at the crown of the arch. As these division points do not fall upon those under the assumed loads, the area of the polygon is given with sufficient accuracy by the product of the sum of the ordinates by the length of one of the equal spaces. The ordinates are scaled and recorded in the table in the second column. The mean of these ordinates, 8.37 feet, is laid off on a vertical through the middle of the span to locate one point,  $o'$ , through which  $k'k'$  must pass to satisfy the condition that  $\Sigma c'k' = \text{zero}$ . The values in column 3, below, are the differences between ordinates at like distances from  $o'$ , as  $o_{16} - o_1$ ;  $o_{15} - o_2$  and so forth. The sum of the product of each difference by the respective distances to the middle divided by the sum of the ordinates is the distance of the center of gravity of the polygon from the middle. Thus, the eccentricity,  $e = 51.57 \div 16 (13 \times \frac{1}{2} + 35 \times \frac{3}{2} + 50 \times \frac{5}{2} + 55 \times \frac{7}{2} + 50 \times \frac{9}{2} + 45 \times \frac{11}{2} + 28 \times \frac{13}{2} + 3 \times \frac{15}{2}) \div 13393 = 0.252$  feet to the right of the middle. Then  $c'k' = 8.37 (51.74 - 6 \times 0.252) \div$

51.74 = 8.12 feet on the left, and  $c'k' = 8.37 (51.74 + 6 \times 0.252) \div 51.74 = 8.61$  feet on the right.

No.	$O$	$O_r - O_l$	$m$	$y$	$k$	$m \cdot y$	$k \cdot y$
1	1.85		- 6.25	1.72	- 6.60	- 10.76	- 11.35
2	4.70		- 3.50	4.62	- 3.64	- 16.17	- 16.80
3	6.92		- 1.30	6.84	- 1.40	- 8.90	- 9.58
4	8.53		+ 0.28	8.60	+ 0.36	+ 2.41	+ 3.10
5	9.80		1.53	9.92	1.68	15.18	16.67
6	10.70		2.37	10.88	2.66	25.80	28.95
7	11.35		3.00	11.52	3.32	34.56	38.30
8	11.72		3.35	11.82	3.62	39.60	42.80
9	11.85	13	3.40	11.82	3.62	40.10	42.80
10	11.70	35	3.18	11.52	3.32	23.60	38.30
11	11.20	50	2.72	10.88	2.66	29.60	28.95
12	11.35	55	1.85	9.92	1.68	18.33	16.67
13	9.03	50	0.55	8.60	0.36	4.73	3.10
14	7.37	45	- 1.14	- 6.84	- 1.40	- 7.80	- 9.58
15	4.98	28	- 3.40	4.62	- 3.64	- 15.70	- 16.80
16	1.88	3	- 6.64	1.72	- 6.60	- 11.43	- 11.35
	133.93		0.00	131.84	0.00	176.15	184.18

With the line  $k'k'$  drawn, the intercepts  $c'k'$  are scaled and tabulated in column  $m$ . The values of  $y$  are the ordinates from the chord to the curve of the gravity axis in (a). The mean value of  $y$ , 8.24 feet, is the distance of  $kk$  above the chord of the gravity axis and  $kk$  is drawn parallel to this chord. The values in column  $k$  are the intercepts  $ck$  in (a). The ordinates,  $m$ , vary inversely as the pole distance and therefore the sums of the last two columns are made alike by a suitable change in the assumed pole distance or

True pole distance: 20,000 = 176.15 : 184.18

True pole distance = 19150 pounds.

Through the trial pole a line is drawn parallel to the chord of the trial equilibrium polygon  $c'c'$  to intersect the load line at  $g$ . The true pole distance is then laid off on a horizontal line through  $g$  to locate the true pole, or in general, on a line parallel to the chord of the gravity axis.

**The True Equilibrium Polygon.** If the inflection points  $p'$  be projected upward to the line  $kk$  in (a), two points  $p$  will be fixed, through which the true equilibrium polygon must pass. Beginning at either point  $p$ , the true equilibrium polygon is



drawn parallel to the corresponding rays through the true pole and the proper points on the load line. This polygon should pass through the other point  $p$ , which fact serves as a check on the accuracy of the work. The true equilibrium polygon is usually drawn whether the solution is by the algebraic or by the graphic method. At the points where the equilibrium polygon crosses the gravity axis of the arch there is no bending due to loads, while the bending moments are everywhere given by the product of the component of the thrust perpendicular to a section and the intercept between the polygon and the axis on the same section. The same result is obtained from the product of the true pole distance and the vertical intercept at the same section.

**Stresses Due to Loads.** In this problem the eccentricities of the polygon are scaled on radial lines at the 16 points of even division of the span and tabulated on page 203. The thrusts are scaled from the force polygon, the difference between those on the right and on the left being due to the difference in loads. The bending moment at any point, as 11, is then  $19,500 \times 0.2 = 3900$  lb. ft. The results given in the column  $h$  are obtained by scaling the thickness of the arch ring at the points of division. The amount of steel reinforcement is assumed to be constant and so the percentage or ratio changes inversely as  $h$ . With these results scaled and tabulated, the stresses are found as described under the subject of combined Flexural and Axial Stresses pp. 90-100. Thus, the compressive stress at point 1 is larger at the intrados than at the extrados since the eccentricity is on that side of the gravity axis. This stress is represented by  $C$  in (81) while that at the extrados is  $C'$  in (82). Since the reinforcement is symmetrically placed with reference to the gravity axis and not far from  $1/10 h$  from the outer edges, Plate VIII may be used if the example falls under Case I. From Fig. 45 it is seen that Case I applies whenever  $e/h$  is less than 0.178 for  $p + p' = 0.52$  per cent. as is the case here. This means that the arch ring at this section is in compression from intrados to extrados and, in fact, the same is true of all parts of this arch. In Plate VIII, for  $p = p' = 0.0026$  and  $e/h = 0.03$ ,  $N_6$  is 1.09 and  $C = N_6 H/bh = 1.09 \times 29400 \div (144 \times 2.08) = 107$  lb. sq. in. at the intrados. At the extrados  $C'$  is found from the same plate where

Point	Eccentricity		Thrust - Pounds		$h$ Feet	$e + h$		% $A + bh$
	Left	Right	Left	Right		Left	Right	
1-16	- 0.06	- 0.32	29400	31280	2.08	0.030	0.154	0.52
2-15	- 0.06	- 0.10	23500	24280	1.84	0.033	0.055	0.58
3-14	- 0.04	+ 0.10	23500	24280	1.60	0.025	0.063	0.67
4-13	- 0.09	+ 0.15	21100	21360	1.46	0.062	0.103	0.74
5-12	- 0.09	+ 0.24	20169	20160	1.34	0.067	0.179	0.81
6-11	- 0.10	+ 0.20	19600	19500	1.20	0.083	0.167	0.90
7-10	- 0.08	+ 0.13	19300	19200	1.16	0.069	0.102	0.95
8-9	- 0.00	+ 0.08	19120	19050	1.14	0	0.104	0.98
Spring	- 0.18	- 0.50	29400	31280	2.17	0.830	0.230	0.50

$N_6'$  is 0.77 and  $C' = 0.77 \times 29400 \div (144 \times 2.08) = 76$  pounds per square inch. In a similar manner the stresses at the intrados and extrados are computed for other points on the arch and inserted in the table. The positive sign indicates tension and the negative sign compression. The numbers in the column headed, for instance, 2 - 15 apply to either point 2 or 15 according to the position of the live load. The position of the line of thrust with reference to the gravity axis determines whether the maximum stresses are on the intrados or the extrados.

**Temperature Stresses.** The range of temperature in the interior of the arch ring is somewhat indefinite. If the roadway be supported on columns which, in turn, rest upon the arch, leaving the same exposed on all sides, the range is evidently greater than when the spandrel filling is solid. For the problem now being discussed it will be assumed that the temperature varies between 25° Fahr. above and the same amount below the normal. As stated in a previous chapter the coefficient of expansion may be taken as 0.0000055 for concrete.

The thrust due to temperature changes is given by formula (144) and, making the proper substitutions, it is found numerically. From (b) Fig. 79 the values of  $y$  are found to be 10.12, 7.22, 5.00, 3.24, 1.92, 0.96, 0.32, and 0.02 feet for subscripts 1 to 8. It will be noted that these values of  $y$  are measured downward from the horizontal line through the highest load points on the arch rather than upward from the chord. The mean value of

TABLE OF FINAL STRESSES IN THE ARCH RING

	1-15		2-15		3-14		4-13		5-12		6-11		7-10		8-9	
	Int.	Ext.	Int.	Ext.	Int.	Ext.	Int.	Ext.	Int.	Ext.	Int.	Ext.	Int.	Ext.	Int.	Ext.
Dead Load .....	-107	-76	-98	-66	-106	-80	-123	-56	-130	-59	-148	-55	-141	-64	-103	-103
Live and Dead Load .....	-183	-4	-99	-4	-8	-132	-2	-145	-40	-149	-61	-194	-63	-159	-13	-110
Temperature, Rise .....	0	-80	0	-50	0	-36	-14	0	-62	0	-113	0	-150	0	-160	0
Temperature, Fall .....	-80	0	-50	0	-36	0	0	-14	0	-62	0	-113	0	-150	0	-160
Shortening .....	-37	0	-20	0	-15	0	0	-5	0	-25	0	-45	0	-60	0	-64
Maximum Compression...	300	156	169	116	157	108	137	164	192	236	261	352	291	369	263	334

Zero stresses indicate some tension to be taken by the steel.  
All stresses are in lb. per sq. in.



$ds/I$  is found from the previous work to be 9.34. Then,  $n$  being the number of divisions in half the arch,

$$H_c = \frac{8 \times 25 \times 51.74 \times 0.0000055}{2 (8 \times 194.75 - 829.44)} \frac{288000000}{9.34} = 1210 \text{ pounds.}$$

Also  $M_c = -1210 \times 28.8 \div 8 = 4350$  lb. ft. The positive sign is used when the temperature is above and the negative sign when it is below the normal. The thrust is applied at the mean of  $y$ , = 3.60, below the crown, and the eccentricity of application is the difference between this value and  $y$ . These distances are given in the second column of the following table. The thickness of the arch ring is  $h$  so  $e/h$  is known and  $k/h$  is taken from Plate X. The value of  $k$  is then found and  $C$ , the stress on the edge of the arch ring which is in the greater compression is determined from (92). If the thickness of the arch be measured radially, the thrust is the component of  $H_c$  normal to the section considered. Thus at points 1 and 16 the normal component of  $Hc$  is 850 pounds.

Point	Eccentricity Feet	$h$ ft.	$e/h$	$k/h$	$k$ in.	$k^2$
1	- 6.52	2.08	3.13	0.240	6.00	36.0
2	- 3.62	1.84	1.97	0.270	6.20	38.4
3	- 1.40	1.60	0.87	0.340	6.54	42.5
4	0.36	1.46	0.25	0.830	14.50	210.3
5	1.68	1.34	1.25	0.330	5.32	28.30
6	2.64	1.20	2.20	0.305	4.32	18.66
7	3.28	1.16	2.73	0.295	4.10	16.81
8	3.58	1.14	3.14	0.295	4.05	16.40

For these values of  $p$  and  $e/h$  it will be found from Fig. 45 that one edge of the arch ring is in tension at every point. At point 1,  $C = (2 \times 850 \times 6) \div [12 \times 36 + 30 \times 0.0026 \times 25 (12 - 25) 12] = 80$  lb. sq. in. The tension in the steel at the other edge will be, from (96), 3300 lb. sq. in. The stresses at other points are found in similar manner and inserted in the table on page 206.

In Fig. 84 the half arch ring is represented as being fixed at the springing line and, at the crown, by the forces exerted by the other half of the arch. The thrust,  $H$ , due to change of temperature, acts outward in case of a rise and inward in case of a fall, on the two cantilevers above and below the line  $kk$ .

With this consideration in mind there can be no ambiguity as to the nature of the stresses resulting from temperature changes alone. Accordingly the temperature stresses at all points are

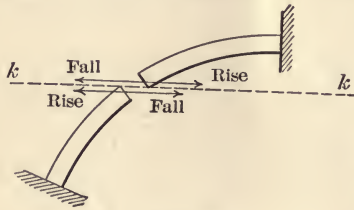

FIG. 84.

notably the eccentricity of the points of application of the thrust. In this case the thrust at each point is found from the force polygon and divided by the areas of the sections of the arch ring at the corresponding points. An average of 110 lb. per. sq. in. seems to be a reasonable value of the compression which produces a shortening equal to that produced by a fall of  $t'$  degrees. Then as  $t'el = Pl \div AE$ ,  $t' = 110 \div (2,000,000 \times 0.0000055) = 10$  degrees or 40 per cent. of 25 degrees. Hence the stresses due to arch shortening are 40 per cent. of those due to fall of temperature and may thus be computed from values of the latter in the table of final stresses.

**Final Tension and Compression Stresses.** The dead load stresses and those due to arch ring shortening are always active, and stresses due to rise and fall of temperature are to be chosen to give maximum tension and compression at intrados and extrados. Thus at 1 or 16 the maximum compression at the intrados is  $-183 - 37 - 80 = 300$  lb. sq. in. The maximum compression at the extrados is  $-76 - 80 = -156$  lb. sq. in. The stresses at other points are found in a similar manner. The stresses in the steel are low and may be found by formula (96).

It will be noted that, in an arch of this variety, the temperature stresses are very important and that in sections near the crown they are greater than those due to the live and dead loads. If the arch be of large span, as 100 feet, the live load should be placed in several positions and the stresses found. Usually four positions are sufficient to give maximum stresses. Professor Wm. Cain suggests<sup>1</sup> a trial of live loads over three, five, six, and ten tenths of the span. A more exact method is

<sup>1</sup> *Trans. Amer. Soc. C. E.*, Vol. IV, pp. 191-193.

computed for both intrados and extrados and the results are placed in the proper columns of the table, page 206.

#### Stresses Due to Shortening.

The average compression in the arch ring is somewhat indefinite owing to several causes,

described by the same author, and others, by<sup>1</sup> which a single load is placed successively at all division points, the effect noted, and all possible combinations used to find the maximum stresses.

Another valuable discussion of possible combinations of stresses in arches is given by Mr. A. H. Fuller in *Trans. Amer. Soc. C.E.* in connection with the paper mentioned above.

**Shearing Stresses.** If the direction of the line of pressure be different from that of the gravity axis the radial component of the resultant pressure is the shear in the section. At point 16 the thrust is 31,280 pounds and by scale the radial component is found to be  $\frac{1}{3}$  of this, or 3910 pounds. The area at this point is  $25 \times 12 = 300$  sq. in., and the shear is 13 pounds per square inch. Stirrups or diagonal tension rods are sometimes inserted for the double purpose of holding the main reinforcement in place and also to prevent distortion due to excessive concentrated loads.

**Final Dimensions.** An inspection of the table of stresses shows that the preliminary assumptions as to thickness of the arch at the crown and at the springing were about right. The appearance is somewhat improved by a curve of smaller radius near the springing line. The reinforcement will be furnished by one inch rods spaced six inches center to center.

**Abutments.** In arches, more than with any other class of structures, it is essential that the foundations be unyielding. The elastic theory is applied upon this assumption and every effort is made to render the hypothesis justifiable. Abutments may fail (a) on account of too great uniform pressure, (b) on account of improper distribution of the pressure through crushing or overturning and (c) by sliding.

In Fig. 85 the thrust, 16, is transmitted by the arch to the amount of 31,280 pounds. This is combined with the weight,  $v$ , of the abutment with the earth filling over it and the thrust,  $h$ , of the earth below the springing lines, if the ground be soft, to

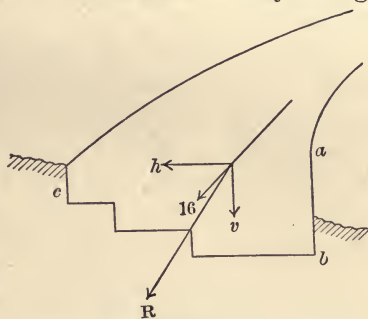

FIG. 85.

<sup>1</sup> "Theory of Solid and Braced Elastic Arches." D. Van Nostrand Co.



form the resultant  $R$ . In this case it is assumed that the foundation is on hard pan capable of sustaining a load of 5 tons per square foot. The distance from the roadway to  $c$  is scaled, the weight of earth filling is computed, the live load for length  $ca$  is found and both are added to the weight of an assumed area of concrete  $abc$  to produce  $v$ . The weight so found is combined with the maximum thrust of the arch ring, as at load 16 of the force polygon, Fig. 79. The maximum unit pressure due to  $R$  is found as in the case of retaining walls, and must not exceed 5 tons per square foot. The details of this abutment design are proposed as a separate problem for the student.

**Symmetrical Proportions.** Attention is called to Fig. 81, which shows a reinforced concrete bridge at Austin, Texas. This structure was designed by Waddell and Harrington, and illustrates the possibility of combining pleasing details with grand proportions.

#### *Sequence of Work in Arch Design*

**General Instructions.** Size of drawing sheet is 22"  $\times$  30"; border, 20"  $\times$  28". The scale of the arch ring is 1 inch = 2 feet, that of the force polygon is 1 inch = 2000 pounds. The arch ring is at the top of the sheet, the force polygon is at the right, and the trial equilibrium polygon is below the arch ring.

**Data.** Clear span, —; rise, —;  $C =$  —;  $S_t =$  — lb. sq. in.; shear in concrete alone, — lb. sq. in.; with diagonal reinforcement, — lb. sq. in.; bond, — lb. sq. in.;  $n = 15$   $E_c = 2,000,000$  inches<sup>4</sup>; per cent. of steel at crown = —. Dead load: concrete, — lb. cu. ft.; earth filling, — lb. cu. ft.; ballast, paving, etc., — lb. cu. ft.

Live load: — lb. per sq. ft. Assume the live load as extending over one-half of the arch ring for spans up to 50 feet. For long spans the live load should also be tried over  $\frac{1}{3}$  and  $\frac{2}{3}$  of the span.

The loads are considered to act vertically unless the rise of the arch is about  $\frac{1}{3}$  of the span.

**Design.** (1) Determine the thickness of the arch ring at the crown by Weld's formula:  $t = \sqrt{s + 0.1s + 0.005 w_l + 0.0025 w_d}$  in inches.

(2) Lay out the arch ring of the clear span and rise, using either segmental circular, a three or a five-centered curve for the

intrados. Use a segment of a circle for the extrados. The thickness at the springing line is from 2 to 2.5 that at the crown, at the quarter points it is about 1.3 that at the crown.

(3) Draw the gravity axis midway between the extrados and intrados. This curve may often be the segment of a circle.

(4) Divide the arch ring by vertical lines into parts such that  $ds/I$  is constant. From 8 to 20 divisions are usually sufficient. For method see page 198. The reinforcement is usually taken, for trial, as about one per cent. of the area of a section of the arch ring at the crown. This is placed from  $1\frac{1}{4}$  to  $2\frac{1}{2}$  inches from the edges.

(5) Construct a reduced contour load line above the arch. Divide the area between the intrados and the reduced contour by vertical lines through the points established in (4). Find the area and center of gravity of each trapezoid to determine the magnitude and point of application of the loads. Number these loads from left to right.

(6) Draw the load line, assume a pole opposite the point between the two loads on either side of the crown, and draw the rays. (The rays may be omitted.)

(7) Draw the trial equilibrium polygon and the closing chord. Scale the ordinates between the chord and the polygon, find the mean ordinate and the eccentricity, and locate  $k'k'$  as described on page 196.

(8) Scale the ordinates between the chord and the gravity axis in (a), Fig. 79, and locate  $kk$ . On  $kk$  plot the points  $p$  from the intersection of the trial equilibrium polygon and the line  $k'k'$ . Tabulate the ordinates to the gravity axis and the trial equilibrium polygon, and compute the true pole distance as indicated on page 196.

(9) Draw the true equilibrium polygon through the points  $p$ . Scale the eccentricities and compute the stresses due to loads at the intrados and extrados in the manner described in Chapter IV. Find the shear at all points.

(10) Compute the thrust due to temperature changes according to formula (144).

(11) Compute the stresses at intrados and extrados due to temperature changes. Refer to Fig. 82 in determining the nature of these stresses.

(12) Find  $t'$ , the change in temperature that would produce

stresses equal to those due to average compression in the arch ring. Find the stresses due to shortening of the arch ring by the ratio  $t \div t'$ .

(13) Make a table of stresses similar to that on page 206, and find the final maximum and minimum stresses at intrados and extrados.

(14) Compare the final stresses with those allowable and make such changes in the thickness of the arch ring or in the amount of reinforcement as are necessary to make the assumed and computed stresses agree.

(15) Design an abutment, estimate the pressures on it, combine its weight with these pressures, and find the maximum resulting pressure on the ground. If the allowable earth resistance be exceeded, increase the width of the footing accordingly.

### *Design of a Beam and Girder Floor*

This design will not be worked out in numerical detail, but the sequence of computation with proper references to foregoing

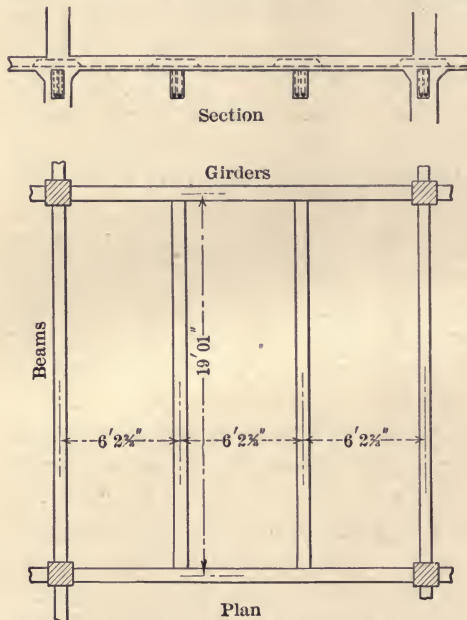

FIG. 86.

pages will be given. The panels will be assumed of the same dimensions and carrying the same load as the girderless floor on page 129, 18 ft. 8 in. by 19 ft. 1 in., and divided as shown in Fig. 86.

The slabs are 6 feet  $2\frac{2}{3}$  inches in span, partially fixed and continuous, and the bending moment may be taken as  $\frac{1}{2} w l^2$ . The thickness may be assumed, to determine the load, as 4 inches, so the live and dead load is  $225 + \frac{1}{3} \times 150 = 275$  lb. sq. ft. Assume the allowable

stresses in steel and concrete to be 16,000 and 600 lb. sq. in. The solution is made by means of Plate I.



**The Beams.** These are 19 ft. 1 in. in length, and carry, beside their own load,  $225 \times 6 \times 19.08$  pounds. The dead load may be assumed at half the added load. The slab forms the flange of a T-beam, of which the web is to be designed. The section area is first determined to resist the shear, as explained in the design of the T-beam, page 157. The width of flange is to be taken in accordance with the recommendation of the Joint Committee, page 150. The amount or percentage of steel may be assumed, and the width of the web made to conform with this assumption, page 82. The negative bending moment may be taken as  $\frac{1}{10} wl^2$ , and the beam is rectangular with double reinforcement rather than of T-section at the supports. In the computations Plate II may be used. It is possible that the section may have to be deepened at the supports to keep the area of steel reasonable. A new depth is assumed and the new percentage of steel is thus fixed, the stresses are computed and a new assumption as to depth is made if necessary. The design of diagonal tension members, stirrups, and bent-up rods is made as explained before. The section at the support is investigated for bond stresses.

**The Girders.** The girders have a span of 18 feet 8 inches, and the loads may be assumed to be applied at the third points. The whole load is taken for trial, as 150 per cent. of the applied load. The width of the web is determined by the shear, and the breadth or depth may be assumed. The amount of steel is computed and the breadth is changed if necessary. For economy, the depth is made as great as circumstances will allow. Negative bending occurs over the supports, the T-section there becomes rectangular, and the depth may be increased for a short distance. The computations are made by means of the formulas for double reinforced rectangular beams and Plate II. Diagonal tension reinforcement is provided for by bent-up rods and stirrups as described before. At the supports the sections are investigated for bond stresses and changes are made in dimensions if necessary. The weights are recomputed, and sections may be verified or altered accordingly. In choosing the steel the difficulties in handling large rods should be considered, and on the other hand a complexity of rods interferes with the best results in pouring the concrete. Rods  $\frac{7}{8}$  inch in diameter are much used in tension, and  $\frac{3}{8}$  and  $\frac{1}{2}$ -inch rods for stirrups.

*Sequence of Work. Design of Reinforced Concrete Hollow Dam*

**General Instructions.** Size of drawing sheet 22"  $\times$  30"; border, 20"  $\times$  28".

Scale of drawing: 1 inch = 4 feet.

Show a vertical section through a buttress at right angles to the axis of the dam. Make this drawing at left end of the sheet.

Show an elevation including a panel and two buttresses, looking upstream. Draw this elevation to the right of the vertical section.

Show all reinforcing bars in both section and elevation; indicate on the vertical section the forces acting, the centers of gravity as used, and diagrams for pressure upon the foundation.

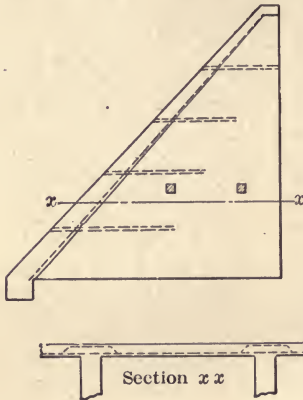

FIG. 87.

**Data.** Elevation of river bed = 120; crest of dam = 160; high water = 158.

The slope of the upstream face = 45°; down-stream face vertical with no wall between buttresses.

Try a crest 2 feet wide; buttresses 2 feet thick at bottom and 1 foot thick at top; spaced 10 feet  $C$  to  $C$ ; struts between buttresses 12"  $\times$  12" spaced 10 feet apart horizontally and 20 feet apart vertically.

The foundation at the river-bed elevation is solid rock, so no concrete floor will be used.

Allowable pressure on foundation 15 tons per sq. ft.; weight of concrete, 150 pounds per sq. ft.;  $C$  = 500 lb. per sq. in.;  $S_t$  = 15,000 lb. per sq. in.;  $v'$  = 30 lb. per sq. in.; for plain concrete, and 100 lb. for reinforced concrete; bond stress = 80 lb. per sq. in.;  $n$  = 15.

**Design.** 1. Calculate thickness of the face slab at the bottom of the dam, at *ele.* 135, and at *ele.* 150, using  $M = \frac{1}{16} w l^2$  for both positive and negative moments. Consider the weight of the slab in calculating the maximum bending moment.

2. Test the thickness of the slab at the buttresses for shear.

3. Find the weight of the concrete in one panel, including slab, struts, and one buttress. Call this  $W$ .

4. Calculate the total water pressure, both vertical and horizontal, on one panel. Call these  $V$  and  $N$  respectively.

5. Find the weight due to concrete and water at bottom of a buttress on a strip one foot wide. This equals  $\frac{W + V}{2}$  since buttress is 2 feet wide at bottom (neglecting the component of the weight of the slab parallel to the face which is carried at the base of the slab between buttresses).

6. Find the center of gravity of a panel of the concrete referred to downstream edge. Find c.g. of slab buttress and struts separately, then take moments to find c.g. of the panel, that is, the point of application of  $W$ .

7. Find point of application of  $H$  and  $V$ .

8. Find center of gravity of  $W$  and  $V$  combined.

9. Find point where the resultant of  $W + V$  and  $H$  cuts the base of the dam referred to down-stream edge.

10. Find maximum and minimum pressures per sq. ft. on the foundation, using general formula:  $P = \frac{W}{l} \pm \frac{6 dW}{l^2}$ .

11. Draw diagram showing distribution of pressure along the base due to the combination of water and concrete.

12. Determine the stability against overturning, taking moments about the downstream edge. Factor of safety of 3.

13. Determine the stability of the dam against sliding using 0.70 as coefficient of friction. Factor of safety of 1. (Adhesion of concrete, and toe and heel walls offer additional resistance.)

14. Determine the effect of shearing resistance upon sliding. (Make heel wall 4 feet deep and wide as base of apron slab. If the required factors of safety are not reached a new design should be made by widening the cut or making a small slope angle.)

15. Determine the factor of safety against crushing.

16. Choose and arrange reinforcing rods in the slab, considering normal stress, shear, bond, and diagonal tension.

17. Put in horizontal rods to bind the slab to the buttresses. No calculations are necessary since the slab is in compression against the buttresses.



18. Reinforce the struts as columns.
19. Determine how such reinforcement for the bending moment due to the weight of the strut is necessary.
20. Compute the cost per linear foot of dam. Concrete \$8 per cubic yard and steel 3 cents per pound.

# INDEX

- Abutments of an Arch, 209
- Adhesion of Concrete to Steel (see Bond). 23, 31
- Aggregate, 12, 140
- Analyses
  - arch, algebraic, 183
  - arch, graphic, 191
  - parabolic assumption 55-68
  - straight line assumption, 38
  - see chap. IV, 37
- Anchoring Bars, 24, 150, 167
- Ancient Reinforced Concrete structures, 1
- Angle of Bent-up Bars, 83
- Areas of Rods and Bars, table 156
- Arches
  - abutments, 209
  - analysis, algebraic 183, graphic 191
  - dead loads, 197
  - depth of keystone, 197
  - earth pressure, 197
  - example of design, 197
  - extrados, 198
  - formulas, general, 184, 185
  - formulas for thrust, moment and shear at crown, 189
  - hingeless, 187
  - intrados, 198
  - live loads, 197
  - moment at crown, 189
  - ring shortening, 191
  - steel reinforcement, 198
  - stresses in ring, 189
  - temperature stresses, 189
  - three-hinge arch, 186,
  - thrust at crown, 189
  - two-hinge arch, 186
- Axial loads 90-101
- Bag of portland cement, weight of, 140
- Bands in columns, 111, 116
- Barrel of portland cement, 140
- Bars, deformed, 24
  - depth of concrete below, 144
  - length to develop tensile strength, 80
  - points of bending up, 77
  - spacing of, 77, 82
  - Table of weights, areas and perimeters, 156
- Beams
  - analyses, 39, 146
  - axial loads, 90
  - continuous, 122, 123, 124, 149
  - diagonal tension, 71
  - diagrams for (see Diagrams)
  - double reinforcement, 44
  - economic proportions, 132
  - formulas (see Formulas)
  - homogeneous, 69
  - horizontal shear, 69
  - manner of failures, 29, 74
  - neutral axis, 26
  - parabolic analysis, 55-59
  - repetition of loads, 32
  - shear, 17
  - slab loads on, 126
  - spacing of tension bars, 82
  - straight line analysis, 39,
  - T-beam (see T-beams)
  - tension failures, 29
  - vertical shear, 68
  - web stresses, 76
- Bond of concrete to steel, 22
  - formula for, 25
  - mechanical, 24
  - stresses in retaining walls, 176
  - tests for, 31
  - working stress, 24, 154
- Broken stone, specifications, 12
  - amount in cu. yd. concrete, 35
- Cement, approximate quantities in cu. yd. concrete, 35
  - barrel, volume, 140
  - barrel, weight, 140
  - cost, ratio diagram, 137
  - in cu. yd. concrete, 35
  - production in U. S., 3
  - specifications, 6
  - tests, 6
- Cinder concrete, 85
- Columns,
  - effective area of, 151
  - failures, diagrams of, 108-109, 110
  - formulas for 103, 111, 117, 120, 121
  - hooped or spiral reinforcement, 112, 113
  - increase in strength due to reinforcement, 104

- longitudinal reinforcement, 107  
 strength of plain columns 105, 106  
 strength of reinforced columns, 112, 113  
   Tests of plain, 105, 106  
   Tests, Considère's, 118  
   Tests, Univ. of Illinois, 105  
   Tests, Watertown, 119  
   Use of, 102  
   working rules for, 152  
 Compression strength of concrete, 16  
 working strength of concrete, 17  
 Concrete, bond with steel 23, 31  
   cinder, 85  
   consistency, 141  
   crushing strength, 16  
   elasticity, 19, 20  
   expansion, 86  
   fatigue of, 31, 32  
   fireproofing, 84, 144  
   heat conductivity, 86  
   ingredients in a cubic yard, 35  
   mixing, 140  
   placing, 141  
   relation to aggregate, 140  
   shrinkage, 143  
   strength of, 14, 15, 16, 17, 18, 19, 23, 31  
   uses, of 4  
   waterproofing, 145  
   working strength, 16, 17, 19, 24, 153, 154, 155  
 Consistency of concrete, 7, 141  
 Continuous beams, 122, 123, 124, 149  
   spans, 147  
 Cracks in walls due to temperature, 87  
 Crathorne, A. R., 122  
  
 Dam, design of hollow, 214  
 Diagonal tension, 68, 154  
 Diagram of sieve analysis, 9  
   stress-strain, 21, 32, 38, 58, 114, 115  
   stresses in beams, 37  
   for rectangular beams, 41  
   double reinforced beams, 47  
   for T-beams, 51  
   full parabolic relation, 59  
   general parabolic relation, 63, 65  
    $k \div d$  in terms of  $q$ , 67  
   stresses in a homogeneous beam, 72  
   of points for bending up bars, 78  
   of distances between cracks, 88  
   for stresses under flexure and axial loads, 93, 94, 95, 97, 99  
   showing ratio of strength of reinforced to plain columns, 104  
   for determining economic proportions in beams, 135  
   showing ratio of cost of steel to that of concrete, 137  
 Double reinforcement of beams, 44  
  
 Earth, bearing power of, 169  
   horizontal pressure of, 165  
   weight of, 166  
 Economic proportions of beams, 132  
 Elastic deformation of steel, 35  
   limit of steel, 35  
 Equilibrium polygon, trial, 202  
 Equilibrium polygon true, 203  
 Expansion and contraction of concrete, 32  
  
 Fatigue of concrete, 31, 32  
 Fineness of concrete, 6  
 Fireproofing of concrete, 84, 85, 144  
 Fires, effect of, on concrete, 85  
 Flexural tests of beams, 25  
 Flexural and axial loads on beams, 90-101  
   axial compression, 92-95  
   axial tension, 101  
   diagrams for, 93, 94, 95, 97, 99  
 Floor slabs, 124-127  
 Floors, beam and girder design, 212  
   girderless, 129  
   loads from slabs, 127  
 Forms, 142, 171, 173  
 Formulas, bond, 25  
   diagonal tension, 71  
   double reinforcement, 44  
   flexural, 39, 40  
   flexural and axial loads, 93-98  
   for arch analysis, 184-191  
   for economic designs of beam, 132, 134  
   for columns, 103, 111, 116, 121  
   T-beams, 49, 53  
   ultimate loads, 56-61  
   web stresses, 76  
 Freezing weather, laying concrete in, 142  
 Frictional resistance of bars, 22  
 Fuller's rule for proportioning concrete, 35  
  
 Girders (see Beams)  
 Gravel, coarseness of, 12  
  
 Heat conductivity of concrete, 86  
 Hingeless arch, 187  
 Historical sketch, 1  
 Hooke's law, 37  
 Hooks, for anchoring, 24, 150



- Hooped columns, 109-118
- Live loads, on highways, 197  
assumptions for design, 157
- Mechanical bond, 24
- Merriman's formulas for continuous beams, 122
- Moments, due to eccentric loads, 91  
in an arch ring, 188
- Mortar, retempering, 141
- Mushroom system of floors, 129
- Neutral axis, 26
- Nomenclature, general, 38
- Parabolic theory of stresses, 55-67
- Perimeters of rods and bars, 156
- Pressure of earth, 165
- Placing concrete, 141  
in freezing weather, 142
- Plates (see Diagrams)
- Portland cement specifications, 6
- Proportioning concrete, 34, 35
- Quantities, ingredients in cu. yd. concrete, 35
- Reinforced concrete, elongation, 32  
fire-resisting qualities, 84, 85  
history of, 1  
repeated loads, 31, 32  
shrinkage, 33  
temperature stresses, 189, 205  
uses of, 4  
working stresses, bond, 24, 31, 154  
compression, 17, 154  
diagonal tension, 150  
shear, 19, 31, 150  
tension, 14
- Retaining Walls, design, 164, 174  
anchoring reinforcement, 171  
bond stresses, 170  
footing, 167, 177  
forms, 142, 171, 173  
reinforcement, 166, 174, 180  
shear at footing, 166  
sequence of computation, 171, 181  
thrust of earth, 165
- Rods (see Bars)
- Rubble concrete, 142
- Sand, easy tests of, 11  
effect of good and bad, 11  
relation to broken stone, 140  
specifications, 7
- Shear definition, 17  
strength of concrete in, 18  
working stresses, 19, 154
- Shrinkage of concrete during construction, 143  
reinforcement for, 152
- Sieve analysis of sand, 9
- Specifications for, aggregates, 12  
cement, 6  
mixing, 140  
sand, 7  
steel reinforcement, 34
- Slab, diagram for solution of, 162  
load distribution to beams, 126  
reinforcement for, 148  
supported on four sides, 125
- Spacing of bars, 77, 149, 156  
of stirrups, 76, 151, 160  
rule for, 82
- Surface finish, 145
- Steel, coefficient of elasticity, 34, 155  
coefficient of expansion, 86  
corrosion of, 84  
specifications for, 34  
strength of, 34  
working strength of, 155, 166, 176
- Stirrups, bond stresses in, 80  
spacing, 76, 151, 160  
stresses in, 80  
table for spacing, 160
- Stress-strain diagram, 21
- Stresses, assumptions for computations, 147
- Tables for analysis of sand, 10  
areas of rods, 156  
bond strength of concrete and steel, 23, 31  
coefficient of elasticity of concrete, 20  
columns, strength of, 106, 107, 112, 113, 118, 119  
compressive strength of concrete, 16, 18, 19  
concrete, ingredients in cu. yd., 30  
determination of neutral axis, 27, 28  
distribution of loads from slabs to beams, 125  
location of  $k'$   $k'$  in an arch, 194  
perimeters of rods, 156  
production of concrete in U. S., 3  
shearing strength of concrete, 18, 19, 31  
spacing of rods, 156  
strength of steel, 34  
stresses in girderless floors, 130  
stirrups, spacing of, 160  
T-beams; strength, of 52  
tensile strength of concrete, 14, 15  
weight of bars and rods, 156
- Talbot, Prof. A. N. tests by, 41

- T-beam, analysis of stresses, 48  
  design, 155  
  relation of floor slab to flange, 148  
  strength of, 52
- Temperature stresses, in arches, 189, 205  
  reinforcement for, 88, 89
- Tests (see Bond, Compression, Shear, etc.)
- Theory of reinforced concrete beams, assumptions, 147
- Three-hinged arch, 186
- Thrust in an arch ring, stresses due to, 191
- Two-hinged arch, 186
- Voids, classification of sand by, 10
- Walls (see Retaining Walls)
- Waterproofing, 145
- Web reinforcement, 24, 75-83, 150, 151
- Weight of bars, 156  
  bag cement, 140  
  barrel cement, 140  
  cubic foot of earth, 166  
  reinforced concrete per cu. ft., 33  
  rods, 156  
  sand per cu. ft., 10
- Working stresses columns, 152  
  concrete, bond, 24, 154  
  compression, 17, 154  
  shear, 19, 154  
  tension, 16  
  for steel, 155















UNIVERSITY OF CALIFORNIA LIBRARY

This book is DUE on the last date stamped below.

Fine schedule: 25 cents on first day overdue  
50 cents on fourth day overdue  
One dollar on seventh day overdue.

MAY 23 1947

13Apr 57 DL

REC'D LD

MAY 21 1957

22Jan'50 MB

14Jun'50 AM

15Dec'52 JK

DEC 1 1952 LU

LD 21-100m-12,'46 (A2012s16)4120

224122

TA 683

B7

*Barthe*



