

ENGIN. MAR 31 1981
CORNELL
UNIVERSITY
LIBRARY



GIFT OF

Louis L. Otto

ENGINEERING

CORNELL UNIVERSITY LIBRARY



3 1924 057 832 457



Cornell University Library

The original of this book is in
the Cornell University Library.

There are no known copyright restrictions in
the United States on the use of the text.

WORKS OF DR. THURSTON.

Materials of Engineering.

A work designed for Engineers, Students, and Artisans in Wood, Metal, and Stone. Also as a TEXT-BOOK in scientific schools, showing the properties of the subjects treated. Well illustrated. In three parts, repeatedly revised, to date.

Part I. The Non-Metallic Materials of Engineering and Metallurgy.

With Measures in British and Metric Units, and Metric and Reduction Tables. 8vo, cloth..... \$2 00

Part II. Iron and Steel.

The Ores of Iron ; Methods of Reduction ; Manufacturing Processes ; Chemical and Physical Properties of Iron and Steel ; Strength, Ductility, Elasticity, and Resistance ; Effects of Time, Temperature, and Repeated Strain ; Methods of Test ; Specifications. 3vo, cloth..... 3 50

Part III. The Alloys and their Constituents.

Copper, Tin, Zinc, Lead, Antimony, Bismuth, Nickel, Aluminum, etc. ; The Brasses, Bronzes ; Copper-Tin-Zinc Alloys ; Other Valuable Alloys ; Their Qualities, Peculiar Characteristics ; Uses and Special Adaptations ; Thurston's "Maximum Alloys" ; Strength of the Alloys as Commonly Made, and as Affected by Conditions ; The Mechanical Treatment of Metals. 8vo, cloth, 2 50
"As intimated above, this work will form one of the most complete as well as modern treatises upon the materials used in all sorts of building constructions. As a whole it forms a very comprehensive and practical book for engineers, both civil and mechanical."—*American Machinist*.

"We regard this as a most useful book for reference in its departments ; it should be in every engineer's library."—*Mechanical Engineer*.

Materials of Construction.

A Text-book for Technical Schools, condensed from Thurston's "Materials of Engineering." Treating of Iron and Steel, their ores, manufacture, properties, and uses ; the useful metals and their alloys, especially brasses and bronzes, and their "kalchoids": strength, ductility, resistance, and elasticity, effects of prolonged and oft-repeated loading, crystallization and granulation ; peculiar metals : Thurston's "maximum alloys" ; stone ; timber : preservative processes, etc., etc. Many illustrations. Thick 8vo, cloth, repeatedly revised, to date..... 5 00

"Prof. Thurston has rendered a great service to the profession by the publication of this thorough, yet comprehensive, text-book. . . . The book meets a long-felt want, and the well-known reputation of its author is a sufficient guarantee for its accuracy and thoroughness."—*Building*.

Stationary Steam-Engines.

Especially adapted to Electric-Lighting Purposes. Treating of the Development of Steam-engines—the principles of Construction and Economy, with descriptions of Moderate and High Speed and Compound Engines. Revised and Enlarged. 8vo, cloth..... 2 50

"This work must prove to be of great interest to both manufacturers and users of steam-engines."—*Builder and Wood-Worker*.

A Manual of the Steam-Boiler : Design, Construction, and Operation.

Containing:—History ; Structure ; Design—Materials ; Strength and other Characteristics—Fuels and Combustion—Heat ; Its Production, Measurement and Transfer ; Efficiencies of Heating-Surfaces—Heat as Energy ; Thermodynamics of the Boiler—Steam ; Vaporization ; Superheating ; Condensation—Conditions Controlling Boiler-Design—Designing the Steam-Boiler—Accessories ; Settings ; Proportioning Chimneys—Construction of Boilers—Specifications ; Contracts ; Inspection and Tests—Operation and Care of Boilers—The Several Efficiencies of the Steam-Boiler—Steam-Boiler Trials—Steam-Boiler Explosions—Tables and Notes ; Sample Specifications, etc. Reports on Boiler-Trials. Seventh edition, revised. 8vo, 925 pages. Very fully illustrated.

\$5 00

Steam-Boiler Explosions in Theory and in Practice.

Containing: Causes of—Preventives—Emergencies—Low Water—Consequences—Management—Safety—Incrustation—Experimental Investigations, etc., etc. With many illustrations, 12mo, cloth.

1 50

"Prof. Thurston has had exceptional facilities for investigating the causes of boiler explosions, and throughout this work there will be found matter of peculiar interest to practical men."—*American Machinist*.

"It is a work that might well be in the hands of every one having to do with steam-boilers, either in design or use."—*Engineering News*.

A Hand-Book of Engine and Boiler Trials, and the Use of the Indicator and the Prony Brake.

Fourth edition, revised. 8vo, cloth. Copiously illustrated.
(Published also in French, as translated by M. Roussel ; Paris, Baudry et Cie.)

5 00

"Taken altogether, this book is one which every engineer will find of value, containing, as it does, much information in regard to Engine and Boiler Trials which has heretofore been available only in the form of scattered papers in the transactions of engineering societies, pamphlet reports, note-books, etc."—*Railroad Gazette*.

Conversion Tables

Of the Metric and British or United States WEIGHTS AND MEASURES. 8vo, cloth

1 00

"Mr. Thurston's book is an admirably useful one, and the very difficulty and unfamiliarity of the metric system renders such a volume as this almost indispensable to Mechanics, Engineers, Students, and in fact all classes of people."—*Mechanical News*.

Reflections on the Motive Power of Heat,

And on Machines fitted to develop that Power. From the original French of N. L. S. Carnot. 12mo, cloth. Supplemented by Sir Wm. Thomson's commentary. Revised. Portraits of Carnot and Lord Kelvin.

2 00

From Mons. Haton de la Goupillière, Director of the *Ecole Nationale Supérieure des Mines de France*, and President of *La Société d'Encouragement pour l'Industrie Nationale* :

"I have received the volume so kindly sent me, which contains the translation of the work of Carnot. You have rendered tribute to the founder of the science of thermodynamics in a manner that will be appreciated by the whole French people."

History of the Growth of the Steam-Engine.

(Pub. by D. Appleton & Co., N. Y.) 12mo, cloth. Revised to date.

1 75

Heat as a Form of Energy.

(Pub. by Houghton, Mifflin & Co., N. Y.) 12mo, cloth.

1 25

Life of Robert Fulton.

(Pub. by Dodd, Mead & Co., N. Y.) 12mo, cloth.

75

A Manual of the Steam-Engine.

A Companion to the Manual of Steam-Boilers. By Prof. Robt. H. Thurston. 2 vols. 8vo, cloth. Very fully illustrated. Repeatedly revised, to date. \$10 00

Part I. History, Structure, and Theory.

For Engineers and Technical Schools. (Advanced Courses.) Nearly 1000 pages. Fifth edition, revised and enlarged. 8vo, cloth. 6 00

Part II. Design, Construction, and Operation.

For Engineers and Technical Schools. (Special courses in Steam-Engineering.) Nearly 1000 pages. Fourth edition, revised and enlarged. 8vo, cloth. 6 00

Those who desire an edition of this work in French can obtain it from Baudry et Cie., Rue des Saints-Pères, 15, Paris.

"We know of no other work on the steam-engine which fills the field which this work attempts, and it therefore will prove a valuable addition to any steam-engineer's library. It differs from other treatises by giving, in addition to the thermo-dynamic treatment of the ideal steam-engine, with which the existing treatises are filled *ad nauseam*, a similar treatise of the *real* engine."—*Engineering and Mining Journal, New York City.*

"In this important work the history of the steam-engine, its theory, practice, and experimental working are set before us. The theory of the steam-engine is well treated, and in an interesting manner. The subject of cylinder condensation is treated at great length. The question of friction in engines is carefully handled, etc., etc. Taken as a whole, these volumes form a valuable work of reference for steam-engine students and engineers."—*Engineering, London, England.*

"The hope with which we concluded the notice of the first volume of this work has been realized, and our expectations in regard to the importance of the second have not been disappointed. The practical aim has been fully carried out, and we find in the book all that it is necessary to know about the designing, construction, and operation of engines; about the choice of the model, the materials and the lubricants; about engine and boiler trials; about contracts. The volume, which closes with an original and important study of the financial problem involved in the construction of steam-engines, is necessary to constructors, useful to students, and constitutes a collection of matter independent of the first part, in which the theory is developed. *The publication is a success worthy of all praise.*"—Prof. FRANCESCO SINI-GAGLIA, *Bollettino del Collegio degli Ingegneri ed Architetti, Naples.*

Treatise on Friction and Lost Work in Machinery and Mill Work.

Containing an explanation of the Theory of Friction, and an account of the various Lubricants in general use, with a record of various experiments to deduce the laws of Friction and Lubricated Surfaces, etc. Copiously illustrated. 8vo, cloth. Repeatedly revised, to date. 3 00

"It is not too high praise to say that the present treatise is exhaustive, and a complete review of the whole subject."—*American Engineer.*

Development of the Philosophy of the Steam-Engine.

12mo, cloth. 0 75

"This small book of forty-eight pages, prepared with the care and precision one would expect from the scholarly director of the Sibley College of Engineering, contains all the popular information that the general student would want, and at the same time a succinct account covering so much ground as to be of great value to the specialist."—*Public Opinion.*

The Publishers and the Author will be grateful to any of the readers of this volume who will kindly call their attention to any errors of omission or of commission that they may find therein. It is intended to make our publications standard works of study and reference, and, to that end, the greatest accuracy is sought. It rarely happens that the early editions of works of any size are free from errors; but it is the endeavor of the Publishers to have them removed immediately upon being discovered, and it is therefore desired that the Author may be aided in his task of revision, from time to time, by the kindly criticism of his readers.

JOHN WILEY & SONS.

43 & 45 EAST NINETEENTH STREET.

[Frontispiece.]

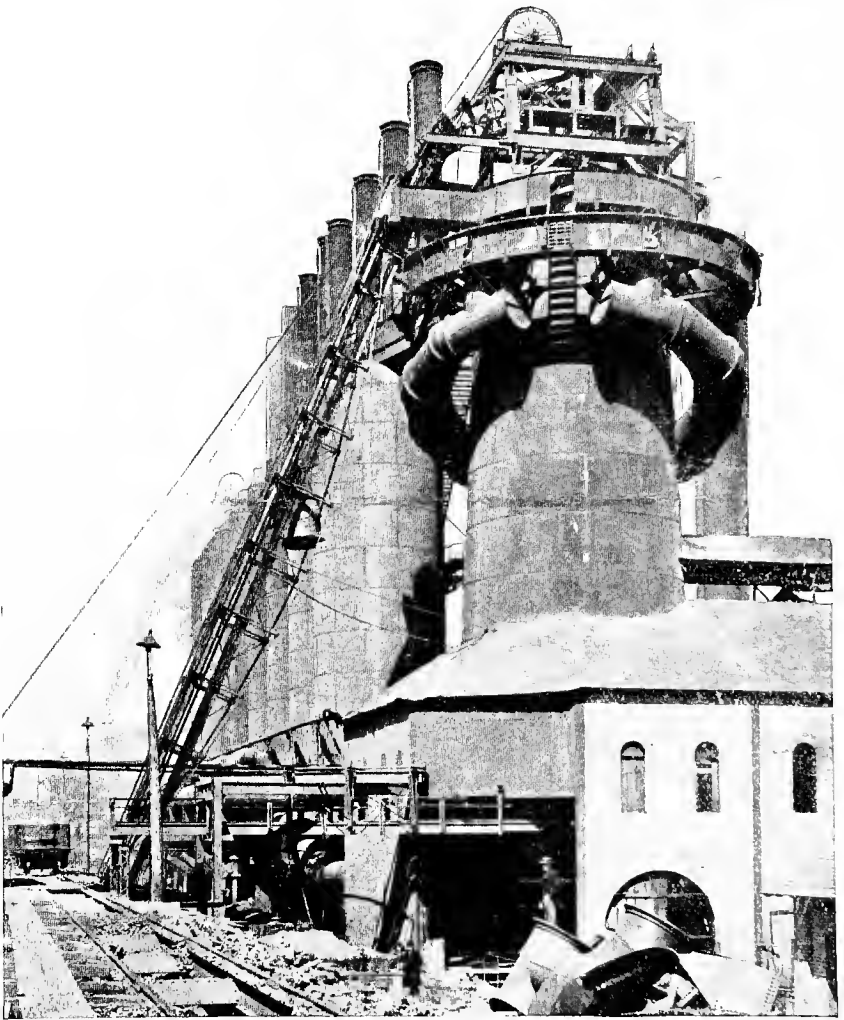

BLAST-FURNACE
WITH STOVES AND BUILDINGS.

A TREATISE
ON
IRON AND STEEL.

PART II.
MATERIALS OF ENGINEERING.

BY
ROBERT H. THURSTON, M.A., LL.D., DR. ENG'G,
DIRECTOR OF SISLEY COLLEGE, CORNELL UNIVERSITY; PAST PRESIDENT AMERICAN SOCIETY
OF MECHANICAL ENGINEERS; MEMBER OF AMERICAN SOCIETY CIVIL ENGINEERS,
AMERICAN INSTITUTE MINING ENGINEERS, SOCIÉTÉ DES INGÉNIEURS CIVILS,
VEREIN DEUTSCHER INGENIEURE, OESTERREICHISCHER INGENIEUR-
UND ARCHITEKTENVEREIN, INSTITUTION OF ENGINEERS AND
SHIPBUILDERS OF SCOTLAND, BRITISH INSTITUTION OF
NAVAL ARCHITECTS; FELLOW OF AM. ASSOC.
FOR ADVANCEMENT OF SCIENCE, NEW
YORK ACADEMY OF SCIENCES,
ETC., ETC., ETC.

NINTH REVISED EDITION.

FIRST THOUSAND.

NEW YORK:
JOHN WILEY & SONS,
LONDON: CHAPMAN & HALL, LIMITED.

1903.

COPYRIGHT, 1883,
BY ROBERT H. THURSTON.

COPYRIGHT, 1888,
BY ROBERT H. THURSTON.

COPYRIGHT, 1898,
BY ROBERT H. THURSTON.

COPYRIGHT, 1903,
BY ROBERT H. THURSTON.

CONTENTS.

CHAPTER I.

QUALITIES OF THE METALS.

ART	PAGE
1. Comparison with other Materials.....	3
2. Metals and Alloys.....	4
3. Metal defined.....	4
4. Useful Metals.....	5
5. Distribution of Ores.....	6
6. Requirements of the Engineer.....	6
7. Special Qualities of the Metals.....	7
8. Relative Tenacities.....	7
9. Hardness.....	8
10. Conductivity.....	8
11. Density and Lustre.....	8
12. Ductility and Malleability.....	9
13. Fusibility.....	10
14. Latent Heat.....	12
15. Alloys defined; Qualities.....	14
16. Specific Heats of Metals.....	15
17. Expansion of Metals.....	17
18. Application of Principles.....	19
19. Force of Expansion.....	19

CHAPTER II.

HISTORY, PRINCIPLES, MATERIALS OF METALLURGICAL WORK.

20. Early Ideas of Metallurgy.....	21
21. Valuable Qualities of Metals.....	23
22. Metallurgy defined.....	23
23. Calcination and Roasting.....	26
24. Smelting.....	27

ART.	PAGE
25. Fluxes	27
26. Fuels.....	29

CHAPTER III.

HISTORICAL SKETCH OF IRON MANUFACTURE.

27. Iron ; its properties.....	31
28. Wrought Iron of Ancient Times.....	32
29. Prehistoric Metallurgy.....	32
30. Greek ".....	33
31. Egyptian ".....	34
32. Early Methods.....	35
33. Direct Process.....	37
34. Catalan Forge ; Blast Furnace.....	41
35. Puddling.....	44
36. Six Epochs of Metallurgy.....	45
37. American Iron-making.....	45
38. New England Iron-works.....	49
39. Iron-making in the Middle States.....	52
40. Later Statistics.....	56

CHAPTER IV.

THE ORES OF IRON.

41. Ores Classified.....	58
42. Meteoric Iron.....	60
43. Telluric ".....	61
44. Magnetic ores.....	62
45. Red Hematite.....	64
46. Brown ".....	67
47. Spathic Ores.....	70
48. Clay Iron Ore.....	71
49. Iron Pyrites.....	73
50. Chrome Iron Ores.....	73
51. Titaniferous Ores.....	76
52. Wolfram.....	78
53. Artificial Ores.....	78
54. Deleterious Elements.....	78
55. Value of Ores.....	80
56. Analyzing Ores.....	80

ART.	PAGE
57. Assaying.....	81
58. Determination of Value of Ores.....	82
59. Mushet's Classification of Ores.....	82
60. Relative Value of Ores.....	84
61. Intrinsic " ".....	86
62. Commercial " ".....	87
63. Dressing Ores.....	89
64. Weathering Ores.....	89

CHAPTER V.

REDUCTION OF ORES; PRODUCTION OF CAST IRON.

65. Preliminary Operations.....	91
66. Grading the Ores.....	91
67. Calcination and Roasting.....	91
68. Methods of Roasting.....	92
69. Roasting in Heaps.....	93
70. " " Kilns.....	94
71. Making up the Furnace Charge.....	95
72. Character of Ore desirable.....	95
73. Composition of Charges.....	96
74. Making up Charges.....	100
75. Form and Proportions of Blast Furnaces.....	100
76. Shape of the Furnace.....	104
77. Costs.....	106
78. Putting Furnace in Blast.....	107
79. Chemistry of Reduction.....	108
80. Bell's, Akerman's, other Researches.....	109
81. Charges in the Furnace.....	113
82. Densities and Specific Heats.....	113
83. Size of Blast Furnace.....	114
84. Height " ".....	115
85. Temperature of Furnace.....	115
86. " " Blast.....	117
87. Losses.....	121
88. Record of the Furnace.....	122
89. Cinder or Slag.....	122
90. Casting.....	124
91. Hot-blast Stoves.....	125
92. Whitwell's ".....	129

ART.	PAGE
93. Blowing Engines	130
94. Air Supply	131
95. Hoists	134
96. Air Hoists	138
97. Steam "	139
98. Water Supply	139
99. Steam Boilers	139
100. Stock Houses	140
101. General Arrangement	141
102. Book-keeping	142
103. Locating the Blast Furnace	144
104. Value of a Furnace	146
105. Managing the Furnace	147
106. Grades of Cast Iron	150
107. Bloomary; Catalan Furnaces	151
108. American " "	152
109. Siemens' Process	153

CHAPTER VI.

MANUFACTURE OF WROUGHT IRON.

110. Characteristics of Wrought Iron	155
111. Decarbonizing Processes	155
112. Forge Process	156
113. Refineries	157
114. Puddling Processes	158
115. Boiling	161
116. Theory of Puddling	162
117. New Methods	165
118. Rotating Puddling Machines	166
119. The Puddle Ball	172
120. Mill-Work	173
121. Hammering	176
122. Squeezing	177
123. Rolling	179
124. Rolls	179
125. Roll-trains	182
126. Rail and Beam Mills	183
127. Continuous Mills	183
128. Universal "	183

CONTENTS.

vii

ART.	PAGE
129. Three-high Mills.....	184
130. Reversing “.....	185
131. Distribution of Men.....	186
132. Hewitt's Mill.....	186
133. Power demanded for Rolls.....	188
134. Rate of Cooling.....	189
135. Efficiency of Rolls.....	190
136. Rolled Iron.....	192
137. Forms of Rolled Iron.....	193
138. Wire-drawing.....	196
139. Draw-plates.....	198
140. Resistance in Wire-drawing.....	199
141. Wire-gauges.....	201
142. Effect of Rolling or Drawing on Strength.....	201
143. Peculiar Shapes.....	203
144. Designing.....	204
145. Malleablized Cast Iron.....	205
146. Tin-plate.....	206
147. “ “ making.....	208
148. “ “ weights.....	208
149. Russian Sheet Iron.....	209

CHAPTER VII.

MANUFACTURE OF STEEL.

150. Steel; Definitions.....	210
151. Steel-making Processes.....	216
152. Direct Processes.....	219
153. Carbonization of Iron.....	221
154. Steel of Cementation.....	223
155. Cast Steel.....	226
156. Crucible Steel.....	227
157. Open-hearth Steels.....	231
158. Siemens' Direct Process.....	235
159. Fluxing Steels.....	239
160. Pneumatic or Bessemer Steel.....	241
161. Plant and Apparatus.....	246
162. Operation of the Bessemer Process.....	254
163. Properties of Bessemer Steel.....	258

ART.	PAGE
164. Dephosphorization.....	259
165. Qualities of Steel.....	261
166. Decarbonization of Cast Iron.....	263
167. Chrome and Tungsten Steels.....	266
168. Phosphorus Steels.....	270

CHAPTER VIII.

CHEMICAL AND PHYSICAL PROPERTIES OF IRON AND STEEL.

169. Pure and Commercial Iron.....	272
170. Effect of the Elements on Iron.....	273
171. Chemical Composition of Irons.....	280
172. Analyses of Cast Irons.....	282
173. " " Ordnance Irons.....	285
174. Cold and Hot-blast Irons.....	287
175. Charcoal, Coke and Anthracite Irons.....	287
176. Analysis of Wrought Iron.....	288
177. Chemistry of Cementation.....	296
178. Composition of Crucible Steels.....	297
179. " " Bessemer and Siemens' Steels.....	300
180. Chemistry of the Bessemer Process.....	303
181. Reactions in the Converter.....	304
182. Tungsten, Phosphorus and Chrome Steels.....	307
183. Welding influenced by Composition.....	309
184. Chemical and Physical Tests.....	313
185. Physical Properties of Iron.....	314
186. " " " Cast Iron.....	316
187. " " " Steel.....	317
188. Working Steel.....	318
189. Tempering.....	323
190. Theory of Hardening and Tempering.....	327
191. Hardening by Compression.....	328
192. Corrosion of Iron and Steel.....	328
193. Durability " ".....	331
194. Preservation " ".....	332
195. Paints.....	333
196. Special Preservative Compositions.....	335
197. Protection of Steam Boilers.....	337

CHAPTER IX.

ART.	STRENGTH OF IRON AND STEEL.	PAGE
198.	Forms of Resistance.....	339
199.	Factors of Safety.....	340
200.	Limiting Values of Stress.....	343
201.	Measures of Resistance.....	343
202.	Methods " "	345
203.	Equations of Curves of Resistance.....	346
204.	Series of Elastic Limits.....	347
205.	Strain Diagrams.....	349
206.	Effect of Shock.....	355
207.	Resilience.....	356
208.	Proportioning to resist Shock.....	359
209.	Value of Iron and Steel.....	360
210.	Effect of Composition on Strength.....	361
211.	Conditions Modifying Strength.....	364
212.	Internal Stress and Strain.....	365
213.	Methods of Test.....	366
214.	Testing Machines.....	368
215.	Riehle's Machine.....	368
216.	Gill's "	370
217.	Olsen's "	371
218.	Emery's " Fairbank's Machine.....	372
219.	Impact Tests.....	375
220.	Fairbank's Transverse Machine.....	376
221.	Thurston's Autographic "	379
222.	Form of Test Piece.....	384
223.	Methods of Testing.....	390
224.	" " Record	391
225.	Records of Test	393
226.	" " "	400
227.	Tenacity of Irons	400
228.	" " Commercial Irons.....	404
229.	" variable with Size.....	407
230.	Chain Iron ; Strength.....	409
231.	Wire ; Tenacity.....	413
232.	Strength of Long Bars	415
233.	Effect of Piling and Reworking.....	416
234.	Tenacity of Ingot Irons and Steels	417

ART.	PAGE
235. Resilience of Steels.	422
236. Tenacity of Bridge Steels.	423
237. " " Steel Rails	425
238. " " Steel Boiler Plate.	426
239. Bessemer and Siemens-Martin Steels compared.	427
240. Tenacity of Steel Wire.	428
241. " " Special Steels.	430
242. " " Steel Castings.	431
243. Tests of Steel in Tools.	433
244. Tenacity of Cast Iron.	439
245. Strain Diagrams of Cast Irons.	444
246. Stayed Surfaces.	445
247. Cylindrical Boiler Shells.	448
248. Cast-Iron Cylinders.	450
249. Resistance to Compression.	456
250. " " as determined by Structure, etc.	457
251. Strain-diagrams ; Cast Iron in Compression.	460
252. Long bars in Compression.	461
253. Wrought Iron in " "	462
254. Flues and Cylinders in Compression.	463
255. Columns and Struts.	465
256. Flexure of Columns.	466
257. Long Columns.	466
258. Formulas for Columns	468
259. Geometrical Moment of Inertia.	475
260. Practical Applications.	477
261. Transverse Strength	482
262. Methods of Resistance.	485
263. Theory of Rupture	486
264. Formulas for Beams	488
265. Modulus of Rupture.	489
266. Sections of Beams.	493
267. Beams of Uniform Strength.	495
268. Theory of Elastic Resistance.	496
269. Experiments on Beams.	502
270. Strength of Beams ; Constants	505
271. Tables " "	509
272. Shearing.	517
273. Riveted Work.	518
274. Shearing of Nuts.	521

ART.	PAGE
275. Punching.....	523
276. Torsional Resistance.....	523
277. Strength of Shafts.....	526
278. Strain Diagrams of Metals.....	531
279. " " " Wrought Iron.....	533
280. Inspection of Wrought Iron Test Pieces.....	537
281. Strain Diagrams of Mild Steels.....	539
282. " " " Tool ".....	542
283. Inspection of Steel Test Pieces.....	544
284. Fractures of Surfaces in Tension.....	547

CHAPTER X.

EFFECT OF TEMPERATURE AND TIME ON RESISTANCE; FLOW OF METAL; FATIGUE; WÖHLER'S LAW; LAUNHARDT'S FORMULA.

285. Effect of Heat on Strength.....	550
286. Experiments of Styffe and Sandberg.....	556
287. " " other Investigators.....	559
288. Conclusions as to Change of Temperature.....	566
289. Stress Produced by " " ".....	568
290. Effect of Sudden " " ".....	568
291. " " Age and Exposure.....	576
292. Crystallization.....	578
293. Flow of Metals.....	585
294. Relief of Internal Stresses by Rest.....	588
295. Effect of Time under Stress.....	590
296. Velocity of Rupture; Shock.....	592
297. Rate of Set.....	594
298. Variation of Normal Elastic Limits.....	600
299. Evidence of Overstrain.....	604
300. Effect of Orthogonal Strains.....	608
301. Conclusions Relating to Elastic Limits.....	610
302. Cold Rolling.....	615
303. Effect of Varying Load; Wöhler's Law.....	618

CHAPTER XI.

SPECIFICATIONS; TESTS; INSPECTION.

304. Specifications Generally.....	628
305. " " for Boiler Work.....	631

ART.	PAGE
306. "Short" Irons.....	632
307. Bridge Work, Specifications.....	633
308. Bridge Work, Specifications, Remarks.....	642
309. Structure of Iron and Steel.....	645
310. Standard of Tests.....	647
311. " for Various Classes.....	648
312. Specification for Steel.....	651
313. " " Welded Metal.....	651
314. " " Railway Materials.....	652
315. " " Plate.....	653
316. " " Construction Iron.....	655
317. " " Girders and Floors.....	658
318. British Specifications.....	659
319. Admiralty and Lloyd's Tests.....	659
320. American Specifications.....	660
321. Cooper Lines.....	661
322. Inspector's Duties.....	662

APPENDIX.

Corrosion of Iron.....	667
Requisites for Painting Iron.....	668
Tenacity of Irons and Steels.....	669
Open-Hearth Steels.....	670
Nickel Steel.....	671
Manganese Steel.....	674
Tests of Nickel Steel.....	675
Composition <i>vs.</i> Quality in Irons.....	679
Strength of Steel Balls.....	682
Specification for Steel Pins.....	683
" " Bar Iron and Steel.....	684
" " Stay-bolt Iron.....	684
Tests of Steel Wheels.....	686
" " " of Cast Iron.....	686
" " Axles.....	687
" " Plate and Rivet Steels.....	687

THE MATERIALS OF ENGINEERING.

PART II.

IRON AND STEEL.

IRON AND STEEL.

CHAPTER I.

QUALITIES OF THE METALS.

1. Comparison with other Materials of Construction.—

As has already been seen, the stones, both natural and artificial, have but limited application in mechanical engineering. While their hardness, density, infusibility, and especially their immunity from injury by oxidation, are all valuable qualities, which fit them peculiarly for use in foundations, in architectural constructions, and in positions where compressive stresses and the action of natural destructive agencies only are to be encountered, their comparatively slight tensile strength, the impossibility of making strong joints, and their deficiency in elasticity and resilience, render them totally useless for the majority of the constructions of the engineer.

The several kinds of timber have a wider range of application, and those most used unite great strength with lightness, and are easily worked. There are many kinds of structures, in which wood, therefore, may be used with advantage, and it is not unusual to construct, in timber, framing which is intended to resist considerable forces. In bridge and roof construction, large quantities of timber are employed; vast quantities are used in house-carpentry; and, on account of its lightness, cleanliness, and the ease with which it can be shaped, it is the only material used by the joiner and the cabinet-maker.

In mechanical engineering, however, it has comparatively

few applications. On the western rivers of the United States, it is sometimes used, as it has been for more than half a century, for the "pitmans," or connecting rods of steam engines. On the rivers of the eastern coast, it is still the material usually employed in the construction of the "gal-lows-frames" of the beam-engines generally adopted there in paddle-wheel steamers. Formerly, the framing of machinery for working textile materials, was usually made of wood; it has, however, now been here entirely superseded by iron.

The engineer now seldom finds use for it, except for applications which are somewhat outside his own peculiar province, or for temporary purposes. Even in pattern-making, it seems to be becoming less used, as the progress of the art of "sweeping" moulds, and of making patterns of iron, plaster, and other materials, enables the founder to dispense with it. In bridge construction, except where wood of the stronger and stiffer varieties is plentiful, and where the spans are comparatively short, iron has already taken its place. In architecture, iron is displacing wood as well as stone.

Timber has its disadvantages in the difficulty, if not impossibility, of making the joints of abutting pieces capable of withstanding tensile stress; in the difficulty of giving it any desired form without sacrificing its strength completely by cutting across its grain, and in the difficulty of preserving it from decay and from destruction by fire.

In the construction of machinery, its lack of rigidity, its softness, and its slight strength in comparison with the common and useful metals, are additional and decisive objections to its general application.

2. The Metals and their Alloys are the materials of which the engineer constructs machinery.

It is necessary, therefore, that one of the first steps taken by the student of engineering should be the acquirement of a very complete and accurate knowledge of the sources, methods of preparation, and properties of the useful metals.

3. Metal is the name applied to above fifty of the chemical elements. The larger number of the metals are but

little known, and many are found in such extremely minute quantities, that we are not well acquainted with either their chemical or their physical characteristics. Some approach the non-metallic elements so nearly, in their properties, that they are placed sometimes in the one class, and sometimes in the other. Very few of the metals are well fitted for use in construction, but, fortunately, those few are comparatively widely distributed, and are readily reduced from their oxides or sulphides, in which states of combination they are almost invariably found in nature.

These "useful metals" are iron—in its various forms of cast iron, malleable or wrought iron, and steel—copper, lead, tin, zinc, antimony, bismuth and nickel, and occasionally aluminum, and rarer metals, are used for similar purposes.

From this list of metals, and from their alloys, the engineer can almost invariably obtain precisely the quality of material which he requires in construction. He finds, here, substances that exceed the stones in strength, in durability under the ordinary conditions of mechanical wear, and in the readiness and firmness with which they may be united. They are superior to timber of the best varieties in strength, hardness, elasticity and resilience, and have, in addition, the important advantages, that they may be given any desired form without sacrificing strength, and may be united readily and firmly to resist any kind of stress.

By proper selection, or combination, the engineer may secure any desired strength, from that of lead, at the lower, to the immense tenacity of tempered steel, at the upper limit. He obtains any degree of hardness, or fusibility, and almost any desired immunity from injury by natural destroying agencies. Elasticity, toughness, density, resonance, and varying shades of color, smoothness, or lustre, may also be secured.

4. The Useful Metals, so called, are not found "native," with the exception of copper and bismuth.

Copper is mined, in an uncombined state, in large quantities, in the great metal-bearing region of Lake Superior; and elsewhere it is found combined with sulphur.

Iron is found in every quarter of the globe, combined with oxygen, or not unfrequently with sulphur. The other useful metals all exist in combination with one or the other of these two non-metallic substances.

5. The Laws Governing Distribution of the Ores of the metals are comprehended in the science of geology. The detection of their presence in any locality, and bringing them to the surface of the ground, free from the foreign earthy substances which accompany them, is the work of the mining engineer, and of the miner. The "reduction" of the metals from ores, by chemical and mechanical processes, constitutes the business of the metallurgist. The engineer takes the metals, as they are brought into the market, and makes use of them in the construction of permanent or movable structures.

6. The Requirements of the Engineer include some acquaintance with the general principles, and with the experimental knowledge, which are to be obtained by the study of geology, of mining and of metallurgy, to aid him in selecting the metals used in his constructions; since their qualities cannot always be determined by simple inspection, and it is not always possible to subject them to such tests as he may consider desirable before purchasing. In such cases, a knowledge of the localities whence the ores were obtained, familiarity with the processes of manufactures, and with the nature of the materials employed by the metallurgist, coupled with a knowledge of the effects of various foreign substances upon the quality of the metal, may enable the engineer to judge with some accuracy what metal will best suit his purposes, and what will be likely to prove valueless. He is also thus enabled to judge, should the purchased material prove defective, where the defect in quality originated, and to place the responsibility where it belongs.

The student will seek this knowledge in special works on geology and metallurgy. But brief reference can be made to these subjects here.

7. The Special Qualities of the Useful Metals which give them their importance as materials of construction are.

their *strength, hardness, density, ductility, malleability, fusibility, lustre, and conductivity.*

Strength, or the resistance offered to distortion and fracture, is their most valuable quality. The strength of metals and alloys in general use, has been very carefully determined by experiment, and will be given hereafter.

Of the metals in our list, lead is the least tenacious, and steel is the strongest.

8. The Relative Tenacities are approximately as below, lead being taken as the standard.

TABLE I.
RELATIVE TENACITIES OF METALS.

Lead	1.0	Cast iron.....	7 to 12
Tin.....	1.3	Wrought iron.....	20 to 40
Zinc	2.0	Steel.....	40 to 100
Worked copper.....	12 to 20	Aluminium	10

No two pieces of metal, even nominally of the same grade, have precisely the same strength. The figures can therefore only represent approximate ratios; as every variation of purity, structure, or even of temperature, is found to affect their strength.

Cast metal is usually weaker than the same metal, after having passed through the rolls or under the hammer; those which can be drawn into wire, are still more considerably strengthened by that process. Metals are stronger at ordinary temperatures than when highly heated, and "annealing" is usually found to reduce their strength, although frequently increasing their ductility. "Hardening," as in steel, usually produces the contrary effect. The presence of impurities and the formation of alloys produce changes of strength, sometimes increasing, sometimes diminishing it. Thus, the addition of carbon to pure iron increases its strength up to a limit, which, being passed, a diminution of strength takes place. Alloying iron with other metals generally reduces its strength; and union with sulphur or with phosphorus impairs it very seriously under some circumstances.

Copper alloyed with tin, or zinc, in certain proportions, is

strengthened; and the addition of a small percentage of phosphorus to the alloy has a marked effect in increasing its tenacity and ductility.

9. Hardness varies in the metals as considerably as their tenacity, and, like the latter quality, is greatly influenced in the same metal by very slight changes, either physical or chemical.

Thus, wrought iron is hardened by cold hammering, and softened by annealing. Steel has its hardness wonderfully affected by the process of tempering. The addition of scarcely more than a trace of impurity often produces a marked change in the degree of hardness of other metals.

10. Conductivity, or their power of transmitting molecular vibrations of either heat or electricity, is another property of the metals, upon which is founded many useful applications.

For example: Except for the readiness with which iron conducts heat, accepting it from the hot furnace gases, on the one side, and transmitting it to the water, on the other, we should be unable to construct the steam boiler of this metal. Of the "useful" metals, copper has by far the highest conductivity, and is only second in this respect to gold and silver, the best known conductors. Its conductivity is greatly reduced by the presence of foreign substances.

The powers of conduction for heat and electricity seem to have very similar relative values. Conductivity is reduced by increase of temperature and by presence of impurities.

The following table of relative conductivities was determined by the experiments of Despretz, and very closely confirmed by Forbes.

TABLE II.

RELATIVE CONDUCTIVITIES OF METALS.

Gold	1,000	Zinc	360
Silver	973	Tin	304 *
Copper	878	Lead	180
Iron	374	Marble	25

11. Density and Lustre are less important, but are often

exceedingly useful properties. The specific gravities of metals to be described are as follows:

TABLE III.
SPECIFIC GRAVITIES OF METALS.

(Water = 1.)

Aluminum.....	2.60 to 2.70	Steel	7.80 to 7.90
Antimony.....	6.60 to 6.70	Copper.....	8.60 to 8.90
Zinc.....	6.80 to 7.20	Nickel.....	8.80 —
Cast iron.....	7.00 to 7.35	Bismuth.....	9.00 —
Tin	7.30 to 7.50	Lead.....	11.20 to 11.40
Wrought iron.....	7.60 to 7.80		

The “metallic lustre” is a property of the metals almost peculiar to them, and constitutes one of their marked characteristics.

Polished steel, and an alloy of copper and tin known as *speculum metal*, burnished copper and aluminum, as well as the precious metals, gold and silver, exhibit this beautiful and peculiar lustre very strikingly.

Tin, lead, and zinc, are lustrous, but they are not capable of taking a sufficiently high polish to exhibit this quality in such a degree as the metals first named.

12. Ductility and Malleability are properties of the metals scarcely less important to the engineer than that of tenacity. The ductility of a metal or an alloy is its capacity for being drawn out into wire, by being pulled through holes in the wire drawers' plates, each hole being slightly smaller than the preceding, until the wire reaches a limit of fineness which is determined by the degree of its ductility, and, as well, by the skill of the workman.

Great tenacity, in proportion to the degree of hardness, or high tenacity, a low elastic limit and a certain viscosity, is the combination of qualities required to insure durability.

Gold has been drawn until the wire measured but $\frac{1}{8000}$ inch in diameter, and silver and platinum are nearly as ductile. Iron and copper are the most ductile of the common metals.

The following is a table of the relative ductility of metals :

TABLE IV.

ORDER OF DUCTILITY OF METALS.

1. Gold,	4. Iron,	7. Zinc,
2. Silver,	5. Copper,	8. Tin,
3. Platinum,	6. Aluminum,	9. Lead.

The *malleability* of a metal, or the power which it possesses of being rolled into sheets without tearing or breaking, is determined by its relative tenacity and softness.

Gold is the most malleable of all metals, and has been beaten into sheets of which it would require 300,000 to make up a thickness of one inch.

Wrought iron of good quality, and the softer grades of steel, are very malleable ; the former has been rolled to less than $\frac{1}{1000}$ of an inch (0.00254 centimetre) thickness. Cast iron and hard steels are neither malleable nor ductile.

Copper is very malleable, as well as ductile, if kept soft by frequent annealing ; tin possesses this property, also ; and zinc, although quite brittle when cold, becomes malleable at a temperature somewhat exceeding the boiling point of water ; its temperature being still further elevated, it again becomes brittle, so much so that it may be powdered in a mortar. Some of the copper-tin alloys exhibit the same peculiarity.

Lead can be rolled into quite thin sheets, but it is less malleable than either copper, tin, or the precious metals.

In the following list, the metals named are placed in the order of their malleability.

TABLE V.

ORDER OF MALLEABILITY OF METALS.

1. Gold,	4. Tin,	7. Zinc, *
2. Silver,	5. Platinum,	8. Iron,
3. Copper,	6. Lead,	9. Nickel.

13. The Fusibility of the Metals, or their property of

becoming liquid, at a temperature which is always the same for the same metal, is a quality which has an important bearing upon their useful applications in the arts.

All solids which do not undergo decomposition by heat before reaching that temperature, have definite "melting points."

The metals differ more widely in their temperatures of fusion than even in density. Solidified mercury melts at nearly 40° below zero, Fahr. (− 40° Cent.); while platinum requires the highest temperature attainable with the oxyhydrogen blow-pipe. The more common metals fuse at temperatures quite readily attainable, although none of them melt at temperatures approaching those ordinarily met with in nature.

Some of the metals may even be readily volatilized, and probably all are vaporized, to a slight degree at least, at very high temperatures. Mercury boils at 330° Cent. (626° Fahr.). Zinc can be distilled at a bright red heat, and copper and gold are known to give off minute quantities of vapor at temperatures frequently occurring during the process of manufacture.

By means of extremely delicate processes, M. Violle has lately determined the fusing point of the more refractory metals. The following are given as the exact temperatures for five of these metals in the order of their fusibility: Silver, 1,749° Fahr., 954° Cent.; Gold, 1,863° Fahr., 1,017° Cent.; Copper, 1,890° Fahr., 1,032° Cent.; Platinum, 3,195° Fahr., 1,957 Cent.; Iridium, 3,510 Fahr., 1,988 Cent. It will be seen that pure copper requires a higher temperature to fuse it than gold. Iridium is the most difficult to melt of all metals.

The low temperatures of fusion of tin, lead, bismuth, and antimony, allow of their being readily applied as solders, either alloyed or separately. Cast iron, copper and its alloys, and other metals, melt at temperatures which are easily reached, and the iron and the brass founders are thus enabled by the processes of moulding and casting, to produce the most intricate forms readily and cheaply, and thus, when

desired, to obtain large numbers of precise copies of the same pattern.

Wrought iron requires for fusion, a temperature which can only be obtained with great difficulty and usually at considerable expense. It is, therefore, usually only worked by the processes of forging.

The melting points of some of the more important metals are as follows :

TABLE VI.
TEMPERATURE OF FUSION OF METALS.

	Fahr.	Cent.
Mercury.....	- 39°	- 39°
Ice	+ 32	+ 0
Tin.....	420	216
Bismuth	490	254
Lead.....	630	332
Zinc.....	700	371
Silver.....	1,280	693
Brass.....	1,870	1,021
Copper.....	2,550	1,118
Cast iron.....	2,750	1,510
Wrought iron.....	4,000 (?)	2,201 (?)

The temperatures of fusion of pure iron, or of wrought iron, are very high, and are not precisely known, no means of accurate measurement having yet been applied to their determination.

The table on the following page gives the temperatures at which a series of alloys made under the direction of the Author were cast. They are not the temperatures of fusion, but the lower figures may be taken as usually but little removed from that point.

14. Latent Heat.—In passing from the solid to the liquid state, a certain amount of heat disappears, being expended in producing this change of physical conditions.

Latent Heat, as this is called, varies in amount with different substances. On page 14 are the latent heats of several, as obtained by M. Person, expressed in thermal units.*

* This thermal unit is the quantity of heat required to raise the temperature of unity in weight of water at maximum density, one degree in temperature.

TABLE VII.
ESTIMATED TEMPERATURES OF CASTING OF ALLOYS.

COPPER-TIN ALLOYS.

NUMBER.	COMPOSITION BY ORIGINAL MIXTURES.		WEIGHT OF WATER.	WEIGHT OF METAL.	TEMPERATURES OF WATER, CENTIGRADE SCALE.			ASSUMED SPECIFIC HEAT.	CALCULATED TEMPERATURES.	
	Copper.	Tin.			Initial.	Final.	Range.		Cent.	Fahr.
31	97.5	2.5	907	74	8.3	22.8	14.5	0.094177	1909.9	3469.8
32	92.5	7.5	907	101	12.8	31.7	18.9	0.092231	1871.9	3401.4
33	87.5	12.5	907	149	16.7	42.8	26.1	0.090285	1802.6	3276.6
34	82.5	17.5	907	362	9.4	60.0	50.6	0.088339	1495.1	2723.0
35	77.5	22.5	907	225	15.0	47.3	32.3	0.086393	1554.5	2829.2
36	72.5	27.5	907	157	11.7	33.3	21.6	0.084447	1511.8	2751.8
37	67.5	32.5	907	97	11.1	26.1	15.0	0.082501	1726.2	3148.8
38	62.5	37.5	907	177	10.6	31.7	21.1	0.080555	1373.9	2503.4
39	57.5	42.5	907	129	17.2	32.8	15.6	0.078609	1428.0	2602.4
40	52.5	47.5	907	214	8.3	35.0	26.7	0.076663	1511.1	2751.8
41	47.5	52.5	907	216	12.2	50.5	38.3	0.074717	2205.0	4001.0
42	42.5	57.5	907	328	9.5	47.2	37.8	0.072771	1063.8	1945.4
43	37.5	62.5	907	293	13.9	38.9	25.0	0.070825	1131.7	2067.8
44	32.5	67.5	907	255	28.9	32.2	23.3	0.068879	1756.9	3192.8
45	27.5	72.5	907	85	7.8	18.3	10.5	0.066933	1701.6	3093.8
46	22.5	77.5	907	277	12.2	38.9	26.7	0.064987	1382.7	2519.6
47	17.5	82.5	907	241	15.5	37.2	21.7	0.063041	1331.1	2427.8
48	12.5	87.5	907	104	14.4	22.7	8.3	0.061095	1211.9	2211.8
49	7.5	92.5	907	240	18.9	33.3	14.4	0.059149	966.5	1752.8
50	2.5	97.5	907	154	20.5	27.2	6.7	0.057203	725.3	1337.0

COPPER-ZINC ALLOYS.

NUMBER.	COMPOSITION BY ORIGINAL MIXTURE.		WEIGHTS, GRAMS.		TEMPERATURES, FAHRENHEIT (DEGREES).			ASSUMED SPECIFIC HEAT.	TEMPERATURES OF CASTING, (DEGREES).		REMARKS.
	Copper.	Zinc.	Water.	Metal.	Initial.	Final.	Range.		Fahr.	Cent.	
22	97.5	2.5	Temperature not taken.	
23	92.5	7.5	907	167.26	64	112	48	0.09518	2847.2	1564.	
24	87.5	12.5	907	Temperature not taken.	
25	82.5	17.5	907	277.17	64	140	76	0.09522	2752.3	1511.3	
26	77.5	22.5	907	482.59	68	188	120	0.09524	2558.7	1403.7	
27	72.5	27.5	907	426.95	60	158	98	0.09526	2343.9	1284.4	
28	67.5	32.5	907	577.70	64	180	116	0.09528	2091.8	1144.3	
29	62.5	37.5	907	439.55	63	168	105	0.09530	2441.9	1338.8	
30	57.5	42.5	907	397.42	58	158	100	0.09532	2552.7	1400.4	
31	52.5	47.5	907	339.05	60	142	82	0.09534	2444.3	1339.5	
32	47.5	52.5	907	296.53	54	130	76	0.09536	2568.2	1409.	
33	42.5	57.5	907	388.15	68	158	90	0.09538	2363.3	1295.1	
34	37.5	62.5	907	327.33	64	142	78	0.09540	2407.9	1319.9	
35	32.5	67.5	907	224.45	88	138	50	0.09542	2255.8	1235.4	
36	27.5	72.5	907	221.19	66	112	46	0.09544	2088.7	1142.6	
37	22.5	77.5	907	322.52	62	125	63	0.09546	1981.3	1082.9	
38	17.5	82.5	907	278.40	59	104	45	0.09548	1639.7	893.1	
39	12.5	87.5	907	165.18	68	95	27	0.09550	1647.7	897.6	
40	7.5	92.5	907	197.87	55	92	37	0.09552	1867.9	1019.9	
41	2.5	97.5	907	180.36	67	93	26	0.09554	1464.8	794.3	

TABLE VIII.

LATENT HEATS OF METALS.

	Cent.	Fahr.
Tin	14.25	25.65
Bismuth	12.64	22.75
Lead	5.37	9.67
Water	79.25	142.65
Silver	21.07	37.93
Cadmium	13.66	24.59

15. **Alloys** are formed by fusing together two or more metals. In the alloys, metallic qualities and chemical properties are not always completely altered or masked, as is the case in chemical combinations with the non-metals.

The physical properties of the alloys are, however, sometimes quite different from those of the constituent metals, notwithstanding the fact that the compounds formed are apparently not definite, as in cases of true chemical combinations. It would appear probable that the force of chemical affinity performs some part in the formation of the alloy. It is not improbable that a definite compound is usually formed which either dissolves, or is dissolved in, any excess of either constituent which may be present.

Examples of alloys are seen in gold and silver coins, in which the precious metals are hardened by alloying them with copper, to give them greater durability. Copper is too soft and tough to allow of its being conveniently worked, and it is therefore, for most purposes, alloyed with tin or zinc, and these alloys—bronze and brass—are, by varying the proportions of the metals used, adapted to a wide range of useful application. Alloys of copper and tin exhibit strikingly the fact, noted above, that the alloy may have widely different properties from either constituent.

Speculum metal is composed of 33 per cent. of tin fused with 67 per cent. of copper. Its color is nearly white, it is extremely hard, exceedingly brittle, and takes a magnificent polish. The latter property gives it value for reflectors of telescopes. Its metallic lustre resembles neither of its con-

stituents, and its tenacity is but about 20 per cent. of that of the weaker metal.

Type metal, also, formed by alloying lead and antimony, in the proportions of four of the former and one of the latter, is a hard alloy, capable of being cast in moulds, taking form very perfectly, and it differs greatly in its properties from either lead or antimony.

It is usually found that the temperature of fusion of an alloy is below, and often considerably below, that of either constituent metal. Thus lead, bismuth, tin, and cadmium, melt respectively at 630°, 495°, 420°, and 540° Fahr. (332°, 257°, 216°, and 282° Cent.).

Alloys of 2 parts bismuth, 1 tin, and 1 lead; of 8 lead, 15 bismuth, 4 tin, and 3 cadmium, melt at 208° to 210° Fahr., and at 150° Fahr. respectively (98° to 99°, and 66° Cent.). Another alloy of lead with antimony—50 parts of the former to 1 of the latter—gives a metal much stronger and harder than lead, yet flexible, and possessing no traces of the brittleness of antimony. The strength of alloys is usually greater than that of the metals composing them.

These interesting characteristics of the alloys will be discussed at greater length when treating of those compounds hereafter.

16. Specific Heats.—The effect of heat upon metallic substances in the production of changes of volume and of temperature varies considerably.

The *Specific Heats* of a number are given below; they measure in thermal units the quantity of heat required to change the temperature of a pound or a kilogramme of the metal one degree.

TABLE IX.

SPECIFIC HEATS OF METALS.

Gray cast iron.....	0.1298	Zinc.....	0.0956
Steel.....	0.1175	Copper.....	0.0952
Wrought iron.....	0.1138	Brass.....	0.0939
Nickel.....	0.1086	Tin.....	0.0562
Cobalt.....	0.1070	Bismuth.....	0.0308

Thus the following table exhibits the relationship between the combining numbers and specific heats of the metals; the product of specific heat and of combining number is seen to be very nearly constant.

TABLE X.
SPECIFIC HEATS AND COMBINING NUMBERS.

METALS.	COMBINING NUMBER.	SPECIFIC HEAT (REGNAULT).	PRODUCT.
Aluminum	27	0.2143	5.8
Antimony	122	0.0508	6.1
Arsenic	75	0.0814	6.1
Bismuth	210	0.0308	6.5
Cadmium	112	0.0567	6.3
Copper	63.5	0.0951	6.0
Gold	196	0.0324	6.4
Lead	207	0.0314	6.4
Iron	56	0.1138	6.1
Magnesium	24	0.2499	6.0
Manganese	55	0.1217	6.7
Mercury (solid)	200	0.0325	6.5
Nickel	59	0.1089	6.4
Palladium	106	0.0593	6.3
Platinum	197.6	0.0329	6.5
Potassium	39.1	0.1695	6.5
Silver	108	0.0570	6.2
Sodium	23	0.2934	6.7
Tin	118	0.0562	6.6
Zinc	65	0.0956	6.2

The specific heats are slightly variable with change of temperature. This change has been carefully studied only in a few cases. Holman deduces,* by collating results of experiments published by known authorities, for the specific heat of iron :

$$\left. \begin{aligned} k &= 0.10687 + 0.0000304(t^\circ - 32) + 0.0000000238(t - 32)^2 \\ k &= 0.10687 + 0.0000547t + 0.0000000428t^2 \end{aligned} \right\} \dots (1)$$

for the Fahrenheit and Centigrade scales respectively.

For platinum he obtains :

$$\left. \begin{aligned} k &= 0.0328 + 0.000003022(t - 32) + 0.00000000009(t - 32)^2, \\ k &= 0.0328 + 0.00000544t + 0.00000000016t^2, \end{aligned} \right.$$

* *Journal Franklin Institute*, August, 1882.

while Richards gives for aluminium,

$$K = 0.222 + 0.0001t^\circ \text{ (Cent.)} \dots \dots \dots (2).$$

The figures given in the table above are mean values between the temperatures of freezing and of boiling, of the quantity of heat, in thermal units, required to produce a change of temperature of one degree. Their values have been shown by Dulong and Petit to increase with the rise of temperature, as does the specific heat of water itself. When melted their specific heats are greater than when solid. The specific heat of tin, which, when solid, is 0.0562, becomes 0.0637 when liquid. The same is true of water, the specific heat of which being 1, that of ice is 0.504.

The specific heats, as above given, may be considered to represent the number of units of water which would be raised in temperature one degree by the addition of the amount of heat which would raise one unit of weight of the metal one degree. Specific heat is sometimes called "Capacity for Heat."

17. The Expansion of the Metals by increase of temperature is exhibited by the following table of *coefficients of linear expansion*.

TABLE XI.

COEFFICIENTS OF EXPANSION OF METALS [32° F. (0° C.) TO 212° F. (100° C.)]

Glass.....	0.000,861,30
Platinum.....	0.000,884,20
Steel, soft.....	0.001,078,800
Iron, cast.....	0.001,125,000
Iron, wrought.....	0.001,220,400
Steel, hardened.....	0.001,239,500
Copper.....	0.001,718,200
Bronze.....	0.001,816,700
Brass.....	0.001,878,200
Tin.....	0.002,173,000
Lead.....	0.002,857,500
Zinc.....	0.002,941,700

Mr. J. E. Howard finds the coefficient for iron and steel to vary from 0.0000067302 per degree Fahr. to 0.0000061700, the latter for hard tool steel.

These coefficients are not absolutely constant, but vary with the physical conditions of the metals. They are not the same with the same material in its form of cast, rolled, hammered, hardened, or annealed metal. The value of the coefficient of expansion also increases slightly with increase of temperature.

To determine the length, L' , of a bar at any given temperature, t' , knowing its length, L , at any other temperature, t , we have the formulas:

$$L' = \frac{L\left(1 + \frac{at'}{180}\right)}{1 + \frac{at}{180}}, \text{ for Fahr. scale, (3).}$$

$$L' = \frac{L\left(1 + \frac{at'}{100}\right)}{1 + \frac{at}{100}}, \text{ for Cent. scale, (4).}$$

where a is the coefficient given above.

TABLE XII.

EXPANSIONS OF VOLUME PER DEGREE CENT.*

Glass.....	.00002 to .00003
Iron.....	.000035 to .000044
Copper.....	.000052 to .000057
Platinum.....	.000026 to .000029
Lead.....	.000084 to .000089
Tin.....	.000058 to .000069
Zinc.....	.000087 to .000090
Brass.....	.000053 to .000056
Steel.....	.000032 to .000042
Cast iron.....	about .000033

These results are partly from direct observation, and partly calculated from observed linear expansion.

* Abridged from Watts's *Dictionary of Chemistry*.

The coefficients of cubical expansion are obtained by multiplying those of linear expansion by three.

The freezing point being assumed as a standard of temperature, in these applications we may determine readily the density of a metal at any other temperature, since the density will vary inversely as the volume.

If the volume at standard temperature be 1, and A the coefficient of cubical expansion, we may construct a formula to determine the density D' at any given temperature; it will be as follows:

$$D' = \frac{D(1 + At)}{1 + At'} \dots \dots \dots (5).$$

Alloys usually have coefficients of expansion nearly equal to a mean of the coefficients of the metals composing them.

18. Applications of the Principles just stated are met with very frequently in the arts; and the engineer constantly finds occasions arising on which he must keep the effects of change of temperature carefully provided for.

Steam pipes are fitted with expansion-joints. Castings are given proportions quite different, frequently, from those dictated by the consideration simply of the laws of resistance to mechanical force. In laying railroad track the rails are, in cold weather, placed with a considerable space between their ends, to allow for expansion under the heats of summer. Grate bars are fitted loosely into their places to allow for their expansion after the fire has been started.

19. The Force with which Contraction or Expansion takes place is, within ordinary ranges of temperature, proportioned to the extent of the range.

Barlow's experiments indicated that a bar of iron might be stretched $\frac{1}{10000}$ of its length for each ton (1,016 kilogrammes) of stress per square inch of section. This increase of length is produced by a change of temperature of 16° Fahr. (9° Cent.). A pound of iron undergoing a change of temperature of 180° Fahr. (82° Cent.), increases about $\frac{1}{80}$ in volume, and is capable of doing 16,000 foot pounds (2,212 kilogramme-metres) of work by the expenditure of this heat.

It sometimes becomes necessary, in designing bridges and other constructions, to calculate with care the probable magnitude and effects of forces arising from changes of temperature, where parts are confined, as well as in the amount of change in dimensions with change of temperature, when they are not rigidly fixed.

In estimating strains arising from expansion and contraction with changes of temperature, it is advisable to base the calculations, if possible, upon experimental determinations of the elasticity and of the expansion of the metal which it is proposed to use, since the various grades of the same metal often differ considerably in both expansibility and extensibility. Such calculations will be given in the chapters on strength of iron and steel.

Many cases occur in which it is impossible to estimate, even approximately, the magnitude of forces brought into action by changes of form due to alteration of temperature.

In some cases these forces will be liable to produce rupture, whatever the amount of metal introduced to meet the stress, and increasing the size of parts only renders it more certain that fracture will take place. This is especially true of castings made in brittle and inelastic metal, as ordinary cast iron. Glass vessels for laboratories, and the water-gauge glasses for steam boilers, are purposely made thin to enable them to meet safely sudden and local changes of temperature. Such forces are frequently important elements of weakness in structures. Explosions of steam boilers have occurred in consequence of strains produced by unequal expansion of portions subjected to varying temperatures; and new designs for boilers should always be examined with the greatest care to determine whether such injury can occur. These effects of heat upon the metal must, therefore, be carefully studied while designing parts of machinery or other structures intended to be made of cast iron, or of hard bronze, or brass, and with special care when of large size.

CHAPTER II.

HISTORY, GENERAL PRINCIPLES, AND MATERIALS OF METAL LURGICAL WORK.

20. **The Ancients**, at the commencement, and immediately before the Christian era, were familiar with but seven metals. In still earlier days, and before the most advanced of the human race had fairly emerged from barbarism, the only materials used in the rude constructions of those times were wood and stone.

The weapons of man, in prehistoric times, were at first, made of hard wood, of bone, or of stone, fashioned with long and patient labor, into rude and inefficient forms. As the race gradually advanced in knowledge and intelligence, they acquired, by some fortunate circumstance, a knowledge of the methods of reducing from the ores the more easily deoxidized metals, and, still later, those which cling with tenacity to oxygen, and require considerable knowledge and skill, and special apparatus for their reduction to the metallic state; and at a still very early period, they applied the more common and more generally useful metals in their rude manufactures.

It has thus happened, that mankind has passed through what are designated by the geologists, as the ages of stone, of bronze, and of iron, and may be considered as having just entered upon an age of steel.

The earliest of historical records indicate that, long previous to their date, some metals were worked, although with rude apparatus, and in an exceedingly unintelligent manner. The Bible states that Tubal Cain, the great-grandson of Adam, was an artificer in brass and in iron; and several sacred writers refer to the use of these metals, and of gold and silver, in very early times. Profane writers, also, present

similar testimony ; and the discovery of implements of metal among the ruins of the ancient cities of Asia and Africa, and in the copper mines and other localities of North America, indicate that some knowledge of metallurgy was acquired many centuries before our era.

The Chinese, at a time far back of even their oldest historical records and traditions, seem to have been workers in iron and in bronze.

Evidence has been found, in Hindostan, that the inhabitants of the Indian peninsula, at an era of their history, of which we have lost every trace, were able not only to reduce these metals from their ores by rude metallurgical processes, but that they actually constructed in metal, works which are looked upon as remarkable for their magnitude.

The Chaldeans, four thousand years ago, the Persians, the Egyptians, and the Aztec inhabitants of America, if not an earlier race, had some knowledge of the reduction and of the manufacture of metals.

It is, probably, quite impossible to ascertain when, by whom, or how the first steps were taken in the progress of metallurgy. Ancient writers were quite as ignorant on this subject, as are the metallurgists of the present day. The profane historians invariably either attribute the discovery of useful metals to their gods, or deified those men to whom they supposed themselves indebted for discovery or improvement of the metals, and of the processes of their manufacture.

It is probable that copper may have been the first metal worked by these early metallurgists, and that tin was next discovered and used to harden the copper, as is done at the present time. In the manufacture of bronze, the ancients became very skillful, probably long before the discovery and use of iron. The bronze implements discovered on both continents have sometimes nearly the hardness and sharpness of our steel tools.

It is only within a comparatively recent period, however, that metallurgy has become well understood. To insure its rapid and uninterrupted progress, it was necessary that the

science of chemistry should be first placed upon a solid basis, and this was only done when, about a century ago, Lavoisier introduced the use of the balance, and by his example, led his brother chemists to employ exact methods of research.

21. The Valuable Qualities of the Metals used in construction are very greatly influenced by the presence of impurities, and by their union with exceedingly minute quantities of the other elements, both metallic and non-metallic.

In the processes by which the metals are reduced from their ores, and prepared for the market, there is always greater or less liability of producing variations of quality and differences of grade, in consequence of the impossibility of always avoiding contamination by contact with injurious elements during these operations, even where the ore was originally pure.

It is necessary, therefore, to learn something of these methods of preparation, and of the manner in which the several elements, which may be expected to be found present in the manufactured metal, affect its quality.

22. Metallurgy is the art of separating the metals from the chemical combinations, in which they are met in nature, freeing them from impurities with which they may be mechanically mingled, and reducing them to the state in which they are found in our markets, and in which they are adapted for application in construction.

The chemical combinations from which the useful metals are obtained, are usually either the sulphides or the oxides. The common ores of iron are peroxides, either hydrated or anhydrous, and copper is generally, except in the Lake Superior mining region of the United States, reduced from the state of sulphide.

Lead is usually found combined with sulphur, forming a sulphide known as galena.

Zinc is found and mined as an oxide, as a sulphide, and also as carbonate and silicate.

The sulphide of iron is rarely or never mined as an ore

of iron, although abundantly distributed in the form of pyrites.

The following table* illustrates the general character of the chief chemical processes employed for the purpose of reducing metals of ordinary occurrence from their ores.

TABLE XIII.

METAL-EXTRACTING PROCESSES IN COMMON USE.

I.—NATIVE METALS.

- By mechanical means..... *e.g.* gold washing.
- By simple fusion (liquefaction)... *e.g.* bismuth.
- By solution in mercury..... *e.g.* gold-quartz.
- By solution in aqueous chemicals. *e.g.* gold-quartz.

II.—SIMPLE ORES; *i. e.*, containing only one metal.

A.—OXIDES.

- Analytic By simple heating..... *e.g.* mercury, silver.
- Single decom- { By heating in hydrogen *e.g.* nickel, iron.
- position... { By heating in carbon oxide..... *e.g.* iron (blast furnace).
- { By heating with carbon (coal, } *e.g.* { tin, arsenic, zinc, iron,
- { coke, etc.)..... } *e.g.* { antimony.

B.—CHLORIDES, FLUORIDES, ETC.

- Analytic By heating alone. *e.g.* platinum, gold.
- { By heating in hydrogen *e.g.* silver.
- Single decom- { By action of cheaper metal, etc.
- position... { By (a) wet processes *e.g.* copper, gold.
- { By (b) dry processes. *e.g.* magnesium, aluminium.
- { By (c) amalgamation processes ... *e.g.* silver.

C.—SULPHIDES.

- Single decom- { By heating with air..... *e.g.* mercury, copper, lead.
- position... { By heating with cheaper metal, etc. *e.g.* mercury, antimony, lead.
- Double de- { By roasting to oxide and reducing } *e.g.* iron, zinc, antimony.
- composition { as above..... } *e.g.* iron, zinc, antimony.
- followed by { By converting into chloride and } *e.g.* silver.
- single de- { treating as above..... } *e.g.* silver.
- composition

D.—CARBONATES.

- Single decom- { By heating with carbon *e.g.* zinc, sodium, potassium.
- position... {
- Double de- { By roasting to oxide and reducing } *e.g.* iron.
- composition { as above..... } *e.g.* iron.
- followed by { By converting into chloride and } *e.g.* copper.
- single de- { treating as above..... } *e.g.* copper.
- composition

* *Metals and Applications.* G. A. Wright, London, 1878.

III.—*COMPLEX ORES*; i. e., *containing more than one metal.*

- | | | |
|--|------------------|----------------------------------|
| I. Alloy extracted by some or other process, as above.... | } <i>e. g.</i> { | silver-lead alloy, spiegeleisen. |
| II. Special processes adopted for extraction of metals separately..... | | |
| | } <i>e. g.</i> | cupriferos pyrites. |
| | | |

It is not the purpose of the Author to describe these processes at length, except in the cases of iron reduction. For the treatment of the metals less frequently used by the engineer, the reader is referred to special treatises on metallurgy.

In the reduction of metallic ores, the earthy impurities are separated as completely as possible by selection, and by mechanical methods, and the operation of smelting follows, during which, by chemical processes, the remaining impurities, whether mechanically or chemically united with the metal, are removed. Earthy matters are removed in the furnace, by the use of properly selected and skillfully proportioned fluxes.

The ores, in their then purified condition, are deoxidized by the action of carbon, or of carbonic oxide, at high temperatures. The sulphides are decomposed by burning out their sulphur, as it is usually found that the affinity of sulphur for the oxygen of the atmosphere is greater than for the metal with which it is found in combination.

In these processes, high temperatures are requisite, as the chemical reaction to be secured can usually only occur satisfactorily when one or all of the substances treated are in either the liquid or the gaseous state.

In the reduction of iron ores, for example, the limestone which is used as a flux must be melted, as must be the silica with which it is to unite, and which it is to remove from the ore, before this desired union can take place; and, also, in order that the silicate formed may flow to the bottom and out of the tap hole of the furnace.

The oxide left after the removal of earthy matters, must be brought in contact with carbon in the gaseous state as carbonic oxide, to insure its reduction; and the finally re-

duced metal must be retained liquid, in order that it may be conveniently removed from the furnace.

The temperatures required and allowable in reducing the various ores are widely different. Iron, copper, bismuth, lead, and nickel are reduced at a bright red heat; while ores of tin, zinc, and manganese must be made white hot, zinc being volatilized in the process of smelting.

Phosphorus is an element which is sometimes met with in the reduction of ores of the useful metals, and its presence in the metals is generally very seriously objectionable. In iron, and particularly in that which is intended for steel making, its existence in measurable quantities is so deleterious as to often condemn the product. It can be removed only with very great difficulty, and metallurgists endeavor to avoid the use of materials containing even a trace of it. The processes adopted for its removal are such as present to it some element for which it has more affinity at high temperatures than for the metal.

The process of reduction of a metal from its ores, and its separation from earthy or metallic impurities, sometimes consists of a single operation, sometimes of two or more.

23. Calcination or Roasting.—The first process to which the ore is subjected, after leaving the mine, is frequently that of *Calcination* or of *Roasting*, by which the ore is disintegrated, and during which sulphur, carbonic acid, and other volatile elements and compounds are eliminated.

In these processes the ores are not mixed with a flux, and the temperature is not raised so high as to produce either fusion or reduction. This is found to be an economical process with nearly all ores of iron, and it is also adopted in the reduction of lead and zinc. The operation is performed either in the open air or in kilns. The former method is adopted with ores capable of withstanding somewhat elevated temperatures, such as the ores of iron.

Roasting in heaps in the open air is conducted as follows: The ground selected is first covered with a layer of wood, or six inches or more in depth of coal. Over this is spread a layer of ore from one to two feet thick, the quantity being

determined for each case by experience, and varying with the character of the ore. Another layer of fuel is added, and this is covered with another layer of ore. Alternate layers are thus added to the pile, until it has reached the desired height. The pile is then fired, and the ore, under the action of the moderate temperature produced by the smouldering fire, is slowly roasted and becomes well prepared for the succeeding process of reduction.

It loses its water, whether of combination or free, gives up its carbonic acid, loses a portion, if not all, of the sulphur which may have been united with it, and the disintegration produced fits it for more thorough intermixture with fluxes, and for more rapid and complete reduction.

The second, and the most usually satisfactory, method with iron ores is that of roasting in kilns.

The fuel and the ore are charged alternately into the kilns in such a manner as to become intimately mixed, and the process is similar in all respects to that which goes on in the previously described method. With kilns, however, the operation can be carried on continuously, the roasted ore being removed at the bottom, and new material supplied at the top as required. This method requires comparatively little space, and does not necessitate the accumulation of immense masses of ore "in stock," as does calcination by the other method. The expense of the construction of the kilns is an objection which is usually more than counterbalanced by the advantages of the process.

24. Smelting.—The final process of reduction, that of *Smelting*, which usually requires still higher temperature, and which immediately succeeds calcination, is conducted in various ways, the outlines of which will be given in those chapters relating to the several metals.

25. Fluxes are used in nearly all of the metallurgical processes, and their characteristics are determined by the special requirements of each case.

Fluxes are, as the name (from *fluo*, to flow) indicates, substances which assist in reducing the solid materials in the

smelting furnace, to the liquid state, forming a compound known as slag, or sometimes as cinder.

It frequently happens that two substances, having a powerful affinity for each other, will unite chemically, when brought in contact, and fuse into a new compound at a much lower temperature than that at which either will melt alone.

Silica fuses only at an extremely high temperature, if isolated, or if heated in contact with bodies for which it has no affinity; but, if mixed with an alkali, as potash, soda, or lime, the mixture fuses readily. The two first-named alkalies are too expensive for general use in metallurgy; but the latter is plentifully distributed, as a carbonate, and it is therefore the flux generally used in removing silica from ores by fusion.

Borax similarly unites with oxide of iron to produce a readily fusible glass; and it is, therefore, often used by the blacksmith as a *flux* when welding iron.

Quartz Sand is also used by the blacksmith for precisely the same purpose. Being composed almost purely of silicic acid, it forms a readily fusible silicate with the oxides of iron, and it is used wherever the mass of iron is of considerable size, and is capable of bearing, without injury, the high temperature necessary for its fusion.

Fluor-spar, a native fluoride of calcium, has been frequently and extensively used as a flux. Its name was given to it in consequence of that fact. It is a very valuable fluxing material, and is used where the expense of obtaining it does not forbid its application. It has special advantages arising from the fact that it is composed of two elements, both of which perform an active and a useful part in the removal of the non-metallic constituents of ores. In the removal of sulphur and phosphorus from iron, it also possesses the great advantage that the resulting compounds produced by its union with those elements are gaseous, and pass off up the chimney instead of remaining either solid or liquid in the furnace, and contaminating the iron by their contact.

Since the aim, in selecting a flux, is, usually, to form, with the impurities to be removed, a readily fusible glass, such

materials are selected, in each case, as are found, by analysis, or by trial, to unite in those proportions which produce such a compound.

The "*slag*" thus formed should usually be a compound silicate of lime and alumina, as free as possible from refractory substances, like magnesia, and from the oxides of the metal treated.

The flux used, therefore, where an ore contains excess of silex, is a mixture of lime and alumina—as, for example, limestone and clay.

Where the ore already contains alumina, limestone only may be needed. In the reduction of iron ores, limestone is very generally the only material added as a flux.

26. The fuels used in engineering and metallurgy are considered very fully in Chapter IV., Part I., of this work.

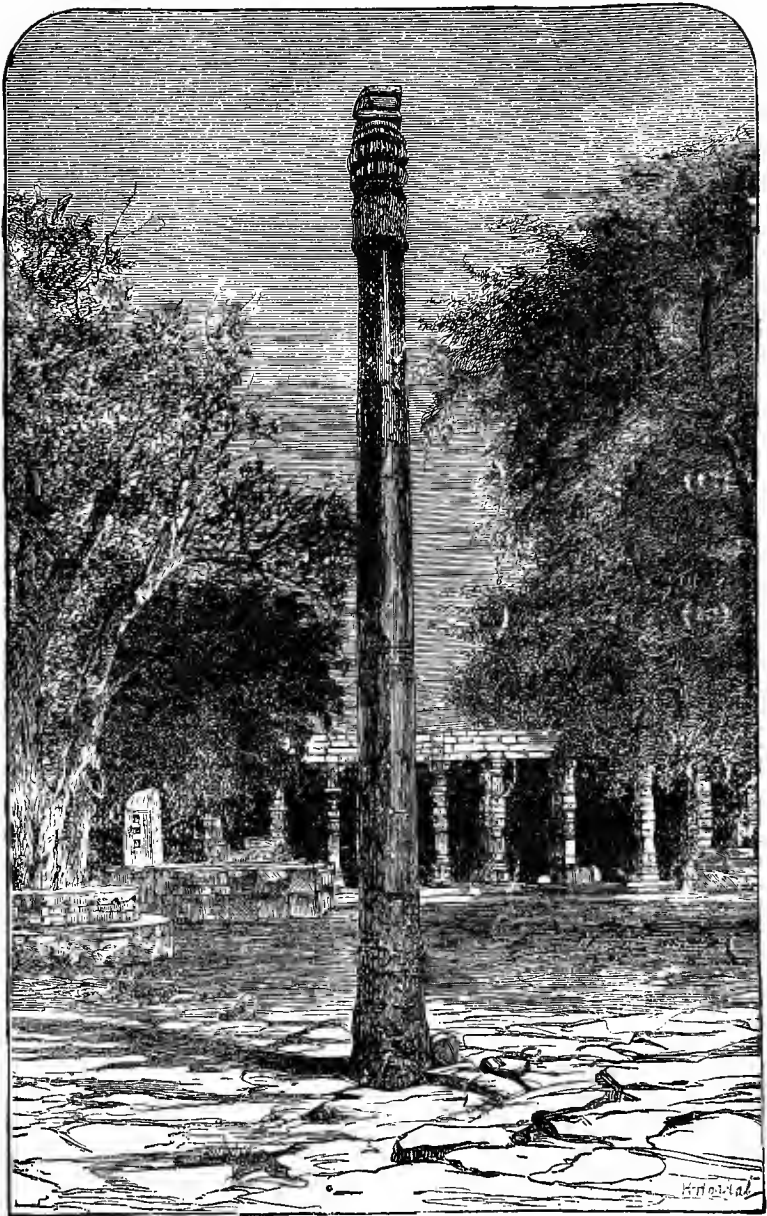

FIG. 1.—THE IRON "LAHT," OR PILLAR, OF DELHI.

CHAPTER III.

HISTORICAL SKETCH OF THE IRON MANUFACTURE.

27. **Iron** is the most important of all the metals, not only because of superiority in its combination of strength, ductility, malleability, facility of welding, of casting, and otherwise assuming useful shapes, and the wide range of character which it takes when united in various proportions with carbon and other elements, but also in consequence of the wide and abundant distribution of its ores, and of the ease with which the metal may be reduced from them by simple metallurgical processes, and the facility with which it may be given any one of its many shades of quality. As cast iron, it is obtained either readily fusible or difficult to melt, hard and brittle, soft and readily worked, or finally as strong and elastic as the cheaper grades of wrought iron. As wrought iron, it may be obtained nearly as soft and ductile as copper, or harder and stronger than any metal except steel. Its property of uniting by welding gives it an inestimable value for general construction. As steel, its great strength and elasticity, and its wide range of quality, as given by tempering, and by variation in proportion of hardening elements, fit it for uses of the utmost importance, and enable it to fill a place for which no other material is nearly as well adapted. Iron ores have a range of distribution and an abundance only comparable to that of the fuels which are essential to their reduction.

28. **Wrought, or Malleable Iron**, has been known from a period which antedates history, and by several nations. A wedge of iron has been found in the Great Pyramid; hence it was known in the time of Moses, 1500 B.C., and in the time of Cheops, 3500 B.C., or possibly in the 7th Egyptian Dynasty, or still further back, in the time of Menes, 4400 B.C.

Mr. A. L. Holley exhibited, at a meeting of the Institute of Mining Engineers, a specimen of iron, which had probably been made centuries before the Christian era, having been found under the obelisk, which is now to be seen in Central Park, New York City. Dr. Wendel found it to have the following composition:

Iron.....	98.738
Carbon.....	0.521
Sulphur.....	0.009
Silicon.....	0.017
Phosphorus.....	0.048
Manganese.....	0.116
Nickel and cobalt.....	0.079
Copper.....	0.102
Calcium.....	0.218
Magnesium.....	0.018
Aluminum.....	0.070
Slag.....	0.150
	<hr/>
Total.....	100.096

Tested by tension, its strength was 54,500 pounds per square inch (3,831 kgs. per sq. cm.) and it stretched 14 per cent., which are fair figures for modern iron.

Notwithstanding the antiquity of iron, its use was generally unknown to the inhabitants of the East Indies, owing probably to the fact that "iron, though the most common, is the most difficult of all the metals to obtain in a state fit for use; and the discovery of the method of working it seems to have been posterior to the use of gold, silver, and copper."

The precious metals, being more fusible, and oftener found in a virgin state, are more readily observed by mankind, and were, therefore, earlier known.

29. In the earlier ages, gold and silver, and particularly copper, were employed for many purposes for which iron is now used.

The most abundant deposits of mineral treasure are usually covered by the largest growth of wood; it has been naturally suggested that in clearing the land by burning the forests, veins of metallic ore lying near the surface would be

fused by the heat, and thus discovered. But iron ore, requiring a more intense heat, remained longer undiscovered. Even when brought to the metallic state, iron, in most of its forms, is not worked as easily as the more malleable, but rarer metals.

We find that the principal weapons, tools, and metallic manufactures of the early ages, and of the half-civilized nations of modern times, were formed of bronze, brass, and alloys of tin with gold, silver, and copper. Nevertheless, the statement that bronze was made before iron is doubted by Percy, the eminent English metallurgist.

When America was first discovered and settled, the use of metals by natives was principally confined to the manufacture of trinkets of gold, silver, and copper, with which to adorn the person. Their best tools and their weapons were sharpened flints and shells; and their only means of felling a tree, and of forming a canoe from its trunk, was by the application of fire. A few tribes possessed the art of casting in gold and silver, and many specimens of their art have been found in the *huacas* or graves of those races.

Weapons of copper alloyed with tin were made by the Peruvians and Mexicans. Lead was known, and knives, of iron which is supposed to have been of meteoric origin, have been found among the Esquimaux and the savages of the Northwest coast.

30. Tubal Cain is stated * to have been an artificer in iron as well as brass.

Homer exhibits a knowledge, not only of the existence of the metal and of the methods of working it, but also of the art of tempering what was probably a crude form of steel, and which afterward became quite abundant among both Greeks and Romans.

The following passage, translated by Cowper, occurs in the description of the games instituted by Achilles on occasion of the death of Patroclus:

“ The hero next an iron clod produced,
Rough from the forge, and went to task the might

* Genesis, iv. 22.

Of King Aetion ; but when him he slew,
 Pelides glorious chief with other spoils
 From Thebes conveyed it in his fleet to Troy.
 He stood erect, and to the Greeks he cried :—
 ‘ Come forth, who also shall this prize dispute.
 How far so e'er remote the winner's fields,
 This lump shall serve his wants five circling years ;
 His shepherd shall not, or his plow need
 In quest of iron seek the distant town,
 But hence he shall himself their wants supply.’ ”

Iliad, b. xxiii.

Æschylus, who lived four hundred years before the Christian era, writes of iron and steel as being worked by the Scythians or Chalybians, and the name Chalybs thus came to be applied by the Greeks to their best qualities of steel ; and through the Latin has acquired a position in our own language, water and chemical compounds containing iron being known as “ *chalybeate*.”

The “ northern iron ” mentioned by Jeremiah, and the “ bright iron ” of Ezekiel, in which the Tyrians traded, were perhaps the product of Chalybia—“ the mother of iron,” as Scythia was called by a Greek poet.

It is thought that Chalybia supplied the early Britons with iron, and they were taught the art of smelting by the Phœnicians. Chariots armed with scythes, spears, broadswords, and iron rings, and also iron money, seem to have existed in Great Britain before the Roman Conquest, but improvements in smelting and working iron were introduced by the followers of Julius Cæsar.

The Romans, in the time of Diodorus Siculus, had already learned of the existence of the still noted ores of Elba.

Pliny, the Elder, speaks of the multitudinous uses of the metal, and quotes Hesiod to the effect that the Dactyli brought iron from Phrygia into Greece nearly fifteen centuries before Christ.

31. The Egyptians, before the time of the Ptolemies, probably had a knowledge of the metal and of the methods of working it ; and the Assyrian antiquities contributed to modern museums frequently contain forged iron, and are

attributed to a period preceding, by nearly a thousand years, the birth of Christ.

Implements, not only of copper (which is said to have been so tempered by a process, no longer known, as to be elastic and hard enough to cut granite with ease), but also iron, have been left to us by the ancient Egyptians.

The existence of the pillar of iron at Delhi, in India (See sketches in figures 1 and 2), indicates that iron working had, at the time of its erection, attained a very considerable degree of advancement. The dimensions of this remarkable column are as follows :

Height above ground, 22 feet (6.7 metres).

As excavated below ground thus far, 26 feet (7.9 metres).

Estimated length not less than 60 feet (18.3 metres).

Lower diameter, 16.4 inches (41.6 cm.).

Upper diameter, 12.5 inches (31.8 cm.).

It contains about 80 cubic feet (2.2 cu. m.) of metal and weighs upwards of 17 tons (or tonnes).

The date of this column (which seems to be made up of a large number of blooms of 60 or 80 pounds (27 to 36 kilogrammes) weight, each welded together at the forge), is not well ascertained, but is supposed to be not far from 900 B. C. Dr. Percy has analyzed and tested a piece of this iron column, of which a cast has been placed in the South Kensington Museum, London, and has pronounced it to be soft wrought iron.

Col. Pearse discovered archaic iron and steel tools in tumuli in India, which are supposed to date from 1500 B.C. Iron beams have been found in Indian temples, and the early Chinese and Egyptian peoples attained some degree of success in iron making on a small scale.

32. Early Methods.—The methods by which these early iron-working nations reduced iron from its ores and gave it its various characteristic forms are not well determined.



FIG. 2.—CAPITAL OF THE "LAHT" OF DELHI.

It is quite certain that both wrought iron and steel were known before cast iron, which seems to be a comparatively modern product.

At the time of the discovery of Great Britain by the Romans, the inhabitants had already learned to reduce iron ores in the rude furnaces which are still in use in a modified form in many parts of the world, and known as "*bloomaris*"—a simple open furnace with a blast produced sometimes artificially, and sometimes merely by leading a draught passage out from under the hearth toward the side from which came the prevailing strong winds.

A *fabrica*, or military forge, was erected at Bath, near the well-wooded, iron producing, hills of Monmouthshire and Gloucestershire, about A. D. 120. There are great beds of iron cinders in the forest of Dean, in the vicinity of Sheffield, and in other parts of England, and in which Roman coins have been found imbedded, which prove the manufacture of iron by the Romans to have attained a very considerable magnitude. The earliest of these masses of scoriæ were found on the hill-tops, where the furnaces had been erected to obtain more powerful currents of air. These currents were admitted through holes on all sides. After the invention of the bellows, the furnaces were built in the valleys. The slag of these ancient bloomaries was rich in iron, and they, for a long time, furnished to more modern furnaces a supply of material from which was made very excellent iron.

The increase of the iron manufacture necessarily caused the destruction of the forests, and this became so serious that an attempt was made, in the first year of the reign of Queen Elizabeth, to prevent it. The destruction of trees was not only prohibited, but also the erection of iron works within certain limits. Similar structures have been found in Belgium, which are attributed to the Romans of Cæsar's time, and Mungo Park found others in modern times in Africa. In these furnaces but a moderate heat could be obtained, but small quantities of ore could be worked at once, and the deoxidation of the ore must have been very imperfect, and the work must have been exceedingly slow. As the tem-

perature attainable was insufficient to fuse the ore, and as the methods of hammering the reduced metal must have been very imperfect, the product was a crude and imperfectly worked wrought iron.

The same method of extracting iron from its ores in a malleable state, as in ancient times, is now practiced by the natives of India, Borneo, and Africa. This ancient method is also still employed in Europe, and in some portions of the United States. It is called the Direct Process, to distinguish it from the modern or Indirect Process, in which cast iron is first produced.

33. The Direct Process.—It is not known when this method originated. The apparatus used is very simple, consisting of a small furnace or hearth and a blowing machine. Very rich ores are used, and charcoal is the only fuel. A small mass of iron is obtained, which is malleable, and is hammered out into a flat, square mass, called a bloom. This is then drawn out under the hammer into a bar. The term bloom is still retained in common use, and is clearly derived, according to Dr. Percy, from the Saxon word *bloma*, which is defined by Bosworth as “metal, mass, lump.” The furnaces in which this process was carried on, were called, as they are still, Bloomaries.

It is apparent from the large accumulations of slag which are found in various parts of India, that the Hindoos have carried on the Direct Process from a very early time, and very little progress seems to have been since made in the art. These furnaces are very small, and hours of unintermitted labor were required to reduce a bloom weighing a few pounds only. The ores used are usually magnetic oxide and rich red and brown hematites.

The bloomary furnaces are divided into three types. The first kind is that employed in the western part of India, and through the Deccan. This is the rudest furnace in use. The other kinds are found in Central India, and in the Northwest. They are quite similar to the simple Catalan forges and to the German Stückofen. They are far superior to the first kind, and are capable of yielding considerable

masses of iron or of crude steel. The blast is produced by bellows. The more common kind consists merely of the skin of a goat. A nozzle of bamboo is inserted at the neck, and at the other end is a slit for the admission of air, with pieces of split bamboo firmly tied on the exterior, to act as a valve. Each furnace is provided with two or more of these goat-skin bellows. The man who works them sits cross-legged between them, working them alternately to keep up a regular blast.

The anvil is made of wrought iron, and is small and nearly square, and has not a beak like a modern anvil. The hammer, tongs, and other tools are quite similar to those familiar to us. The hard woods, such as teak and babool, are used for making the charcoal which is used as fuel. The smaller example of the first kind of furnace is only 2 feet (0.6 metre) high. It yields 5 or 6 pounds of iron (2.2 to 2.7 kilogrammes) at a charge. Those of larger size, such as are used in the Decan, are often 4 feet high (1.2 metres), and produce 30 pounds (13.6 kilogrammes) of iron at a charge. They are circular in form, 10 to 15 inches (25.4 to 38.1 centimetres) in diameter at the hearth, and from 6 to 12 inches (15 to 30 centimetres) at the top. There are two openings at the bottom, through one of which the blast is driven, and the slag and the iron are removed through the other.

The operation of smelting is as follows: The furnace, when new, is dried by keeping a fire in it for some hours. Two pipes or tuyeres about a foot (0.3 metre) long and an inch (2.5 centimetres) in internal diameter, made of earthenware, are placed side by side in the opening at the front of the furnace, projecting about one-fourth their length into the furnace. They are 3 or 4 inches (7.6 to 10 centimetres) above the bottom, and a bellows is attached to each. The openings are then filled with clay. The furnace is first half-filled with charcoal, and the fire is then lighted, and the furnace filled to the top with fuel. As the charcoal sinks down, charges of ore and charcoal are alternately added until the proper quantity of ore has been introduced. The blast is then urged as much as possible, and the maximum available temperature main-

tained to the end of the process. In 4 or 6 hours a bloom is made, the front of the furnace is removed, and the small mass of mingled iron, cinder, and charcoal is withdrawn. The iron should be found hot enough to be hammered without reheating into a moderately sound bloom. A thick viscid cinder is expressed during the latter process.

The second kind of furnace is a cylindrical cavity in a bank of well-tempered clay, from 15 to 18 inches (38 to 45 centimetres) in diameter, and about $2\frac{1}{2}$ feet (0.76 metre) deep. The bank is frequently extended lengthwise, and contains a row of two or three similar cavities. Two openings are made on opposite sides at the bottom of each cavity.

When the charge is ready for removal, it is formed into a ball and withdrawn at the top of the furnace by a pair of tongs. When the bloom is removed, the cinder is tapped off through the front, and fresh charges of ore and fuel are supplied. Six balls of about 20 pounds (9.08 kilogrammes) weight each are made in a day's work of 16 hours. These are hammered without reheating into sound blooms.

The third type of furnace is a structure of clay, in the side of a mound. Its height is from 8 to 10 feet (2.4 to 3 metres) outside, and from 6 to 7 feet (1.8 to 2.1 metres) inside. The bottom of the hearth is thus from 2 to 3 feet (0.6 to 0.9 metre) above the ground outside. It is $1\frac{1}{2}$ feet (0.45 metre) square inside, and of uniform size from top to bottom. The front wall is 5 or 6 inches (12.7 to 15.24 centimetres) thick, and may be readily removed. The bottom of the furnace is made of a tile of dried clay, containing several small holes punched nearly through. It is set at an angle of about 45 degrees with the back furnace wall. This bottom plate is first put in, cow-dung is then introduced to the depth of about 12 inches (30.5 centimetres). On the top of this bed are placed two earthen tuyeres, which are about $1\frac{1}{2}$ feet (0.45 metre) long, projecting into the furnace nearly to the back. The furnace being partly filled with fuel, the fire is lighted, and the furnace is finally filled up.

The blast is applied from the front, and the man working the bellows sits upon a scaffold, raised a little way from the

ground. Fuel and ore are alternately charged, and cinder is tapped out occasionally by pushing an iron bar into the furnace through the holes at the hearth. These holes are then stopped with clay, one after another, as the iron accumulates at the bottom, and rises above them. When the tuyeres are burned away by the iron which has then risen to them, the process ceases. The hearth plate is removed with an iron bar, and the mass at the bottom of the furnace falls out.

The bloom sometimes weighs 150 to 200 pounds (68 to 91 kilogrammes). It is scored by a sharp-edged sledge, and when cold is broken into several pieces. It is usually a mixture of malleable iron and "natural" steel. When it is intended to produce steel, a larger charge of charcoal is adopted and the blast is supplied at a lower pressure. The steely parts, on fracture, resemble often the best blister steel from Swedish iron. They are moderately heated in a charcoal fire, and are cut into pieces of a proper size for edge-tools.

If iron is wanted, the pieces of the bloom are heated to the welding point, and are then worked into bars, often losing in the process all the properties of steel.

Sometimes cast iron is produced. The smelters have much difficulty in separating it from the rest of the iron. When this occurs, the temperature of the furnace has been too high.

Iron is made in Upper Burmah, principally at Puppa. No artificial blast is used here, and this distinguishes the Burmese from the Indian methods of iron manufacture. The direct process is also practiced in the island of Borneo. The natives of Africa manufacture iron by this same process.

The natives of Madagascar have thus made iron from a very early date. Their furnaces are always beside a stream. The ore is broken into small pieces, and very carefully freed from earthy matter. The furnaces are usually sunk 2 or 3 feet (0.6 to 0.9 metre) into the ground, and are made of stones covered outside with clay. A small quantity of charcoal is kindled at the bottom of the furnace, and it is then filled

with ore, either mixed with charcoal or in alternate layers of ore and fuel. It is then covered with clay. The blast is furnished by two pairs of wooden piston pumps, generally made of tree trunks. After the furnace has been some time white hot, it is allowed to cool. When opened, the iron is found in lumps at the bottom.

The earthen floor of the house of the native smith forms the hearth for his forge fire, which is kept together by three or four stones. The bellows are similar to those of the blast furnace. The anvil is about 6 inches (15.24 centimetres) square and 6 inches (15.24 centimetres) high, let into a thick piece of wood fixed in the ground, with the water trough and tools beside it.

34. The Catalan Process: The Blast Furnace.—The Catalan process derives its name from the province of Cata-

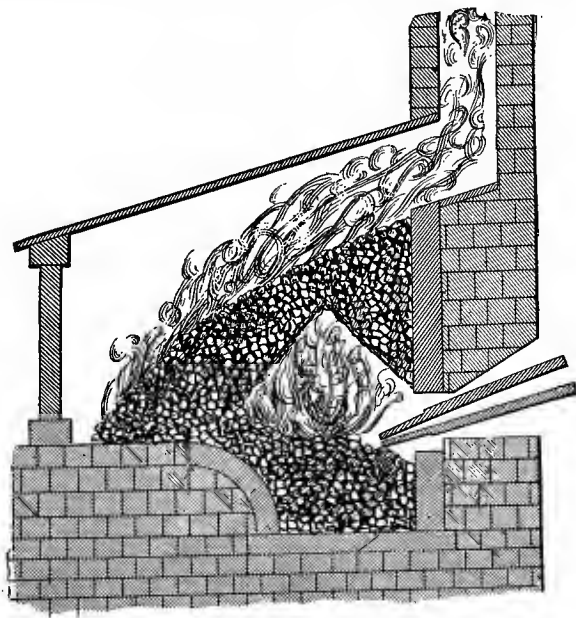

FIG. 3.—THE CATALAN FORGE.

lonia in the North of Spain, where it was practiced to a great extent.

The Catalan Forge consists of a furnace, blowing apparatus, and a hammer. A fall of water of from 11 to 12 feet (3.3 to 3.6 metres) is usually secured to drive the blowing machine. Brown hematite ore is usually preferred, but other ores are used. Charcoal is always used for fuel.

The Direct Process of iron making was practiced in the French Pyrenees as early as A. D. 1293, and has never since been completely given up. Dr. Percy considers it probable that it was established in Spain and France much earlier than the date just given. Originally, it was conducted on but a very small scale.

These rude furnaces, gradually, by increase in size and the application of a more powerful blast, probably grew into the now familiar form of the blast furnace; and the character of the product became as gradually changed, until it assumed the form now known as cast iron.

At what period this revolution in iron manufacture was completed, is not definitely known. It is probable that cast iron was regularly made as early as the middle of the sixteenth century.

During the early part of the seventeenth century, many attempts were made to smelt iron with pit-coal, which had already come into somewhat extensive use for domestic and other purposes.

In 1619, Dud Dudley, a son of Lord Edward Dudley, while superintending his father's furnaces in Worcestershire, England, succeeded in using coal from the neighboring mines as a substitute for charcoal, and made *three* tons per week of cast iron. A patent was issued to Lord Dudley during the same year, and its date marks the beginning of a brief period of successful manufacturing.

In 1651 commercial difficulties drove Dudley out of business, and the use of pit-coal ceased for nearly a century.

About 1735, Abraham Darby, then the manager of the Colebrook Dale Iron Works, made the experiment of treating coal as he had been accustomed to treat wood in preparing charcoal for the blast furnace. After a trial of the coke thus made as a substitute for charcoal (the experiment occupying

several days), his success was complete, and from that time to the present, the use of coal and coke has continued without interruption.

It was but a short time before this that the art of making castings had been acquired or rediscovered by Abraham Darby, the father of the Darby just mentioned. This was in 1706.

Glasgow and its vicinity has now become a very important iron district; this development has been very rapid, particularly since the invention of the hot-blast.

The hot-blast process has produced a complete revolution in the trade of all iron-producing countries, and this change introduced the latest era in the history of this metal—the era which precedes the age of steel.

For this process a patent was secured by Mr. Neilson, in 1824. The patent covered an improved application of air to produce heat in forges and furnaces where bellows or other blowing apparatus are required. The blast was to be heated in a closed air-vessel to a high temperature, before being carried to the furnace, the air vessel being heated by a fire separate from that to which the blast was applied. Such facilities have been thus afforded for the reduction of refractory ores that the quantity of iron produced per ton of coal has been increased very greatly, and the coal does not necessarily require to be coked, or the ores to be calcined.

The more important of the recent changes of the iron manufacture have been: the direct production of wrought iron from rich ores in a reverberatory furnace, accomplished by Mr. Clay, in 1840, and later, by Siemens; the use of oxide of manganese in the production of steel, first attempted by Reynolds, in 1799, and now universally practiced.

Crane, in 1836, and Budd, in 1842, introduced the use of anthracite, stone-coal, or culm in blast furnaces, with a blast of high pressure heated to a high temperature. The application of peat has also been occasionally successful, very good qualities of iron being produced with it in the United States, on the Continent of Europe, and in Ireland.

35. **Puddling.**—In 1783–84, Cort, of Gosport, invented the processes of puddling and rolling, which he foresaw were to become of great importance in the production of iron. He obtained his first patent in 1783, for “a peculiar method and process of preparing, welding, and working various sorts of iron, and of reducing the same into ‘uses’ by machinery, and a furnace and other apparatus adapted to the same purpose.” His second patent was issued in February, 1784, upon his process of “shingling, welding, and manufacturing iron and steel into bars, plates, rods, and otherwise, of purer quality, in larger quantities, by a more effectual application of fires and machinery, and with a greater yield, than any method before put in practice.”

In his first patent he described his system of faggoting and heating scraps and bars, welding them into a mass, and compressing them into form by means of rolls and the hammers. We are, therefore, indebted to Cort for the introduction of the rolling mill.

In his second patent Cort claimed a reverberatory furnace having a concave bottom, into which the fluid metal is run from the smelting furnace. This furnace was heated by coal. He showed how the cast metal could be rendered malleable by a process of stirring with rabbles, or puddling, while exposed to the oxidizing current of flame and air. He describes the stirring of the metal till ebullition ceases, and its collection, as it becomes viscous and pasty, into balls for blooms. He describes the hammering of these to get rid of the slag, and their subsequent reduction to a marketable shape by the processes described in his first patent.

The extensive introduction of the steam engine of James Watt marked the commencement of a new epoch in the history of iron manufacture. It soon came into general use, its immense power, economy, and convenience of application, making it of inestimable value.

Puddling and refining iron by the action of gas flame have been practiced in Silesia a long time, and more recently Mr. C. W. Siemens has applied his regenerative gas furnace to this work. Nasmyth invented the steam hammer in 1842.

It has received many modifications in the hands of Morrison, Sellers, Condie, and others.

The utilization of the waste gaseous products of the puddling furnace was attempted by Teague, in 1832, and Meckenheim, in 1842, and by many later inventors.

Kelly, in the United States, and Bessemer, in Great Britain, have introduced the pneumatic process of making wrought iron and steel by decarbonizing it in a fluid state by forcing through it a multitude of streams of air. Other manufacturers, by modifying the puddling process, are producing a homogeneous and malleable steel in the form of plates and bars.

36. The Six Epochs.—Fairbairn specifies five distinct epochs in the history of the iron trade.

The *first* that of the employment of an artificial blast to accelerate combustion.

The *second* that of the employment of coke for reduction, about the year 1750.

The *third* that of the introduction of the steam-engine.

The *fourth* epoch is that of the introduction of puddling and rolling iron.

The *fifth* is that which is marked by the application of the hot-blast, which has increased the production of iron four-fold, and has enabled the iron master to smelt otherwise useless and unreducible ores.

A *sixth* should be added—that of the introduction of the pneumatic and open-hearth processes of making ingot irons and steels.

37. American Iron Making.—At the date of the colonization of America the demand for iron was greatly increased, while the production of British furnaces, already insufficient for the demand, was declining with the destruction of forests.

The enormous extent of the American forests, and the supposed mineral wealth of America, attracted many adventurers. In their explorations rich deposits of iron ores were discovered, and early attempts were made to work them.

The commencement of the iron manufactures in the British Colonies dates back to the beginning of the seventeenth

century. In 1610 Sir Thomas Gates testified before the Council in London that in Virginia were "divers sorts of minerals, especially of iron ore, lying upon the surface of the ground, which had been tested in England and found to make as good iron as any in Europe."*

In 1619 the London Company sent out a large body of emigrants. Of these, about 150 had been engaged in the manufacture of iron, and it was proposed to erect iron works in the colony. Works for smelting the ore were soon built on Falling Creek, a branch of James River, not far from Jamestown, the first settlement in the colony, and about thirty-two miles from the sea. The first mine opened was found to yield very good iron, and while they were greatly encouraged, and other similar enterprises were about to be undertaken, an attack was made upon them in May, 1622, by the Indians, whose jealousy had unfortunately been aroused, and the whole company with their families, including the superintendent and his men, over 300 people, were destroyed. No iron works were built in Virginia for many years after this event.

The discovery of iron ore seems to have been anticipated by the Court of Assistants in London, who superintended the emigration to Massachusetts Bay, in 1630. Thomas Graves, of Gravesend, in Kent, was authorized by the Company to visit New England, as a "man experienced in iron works, in salt works, in measuring and surveying of lands and fortifications, in lead, copper, and alum mynes." It was afterward agreed that he should visit Naumkeag (Salem) "and exercise his scientific qualifications as circumstances might require, as additional to the services he might render, and which were specified before; he was acquainted with finding lime-stones, planning aqueducts, drawing maps, and architecture." Graves settled at Charlestown, but it is not known that he made any discoveries of mines. *

In November, 1637, the General Court of Massachusetts granted to Abraham Shaw one half the benefit of "any coles

* *A True Declaration of Virginia*, p. 22.

or yron stone w^{ch} shall bee found in any comon ground w^{ch} is in the countrys disposing.”

Bog iron ore was early discovered at Saugus or Lynn, in Eastern Massachusetts, and supplied the furnaces of that colony. It is deposited in the peat bogs and ponds, and large quantities of it were found near Lynn, where the first attempt to manufacture iron in New England was made in 1643-4.

Bridges, in 1643, took to London some specimens of ore from the ponds of Saugus, and uniting with John Winthrop, Jr., who had preceded him two years before, a company was formed called the “Company of Undertakers for the Iron Works.” Winthrop, accompanied by a corps of workmen, returned to New England the same year, and preparations were immediately made for an extensive manufacture of iron, including smelting, forging, and refining of the metal. Heaps of cinder still mark the site of these early works.

At about the same time other works were started at Braintree, Mass., by the same company, and, in 1646, Winthrop commenced another establishment at Pequot, now New London, Conn.

In 1646 the General Court allowed Leader to purchase guns belonging to the colony to smelt at this foundry. Henry Leonard, who aided in making the first castings in America, with his brother, established a forge at Rainham, and was one of the first of a large number of American iron-masters of that name.

Another of the principal workmen who came from England with Winthrop, was Joseph Jenks, a native of Hammersmith, near London, who was called the Tubal-Cain of New England. Lewis, in his History of Lynn, says, “Joseph Jenks deserves to be held in perpetual remembrance in American history as being the *first* founder who worked in brass and iron on the Western Continent. By his hands the first models were made, and the first castings taken of many domestic implements and iron tools. The first article said to have been cast was a small Iron pot, capable of containing a quart. Thomas Hudson, of the same family with the celebrated Hendrick Hudson, was the first proprietor of the lands on

the Saugus River, where the Iron Foundry stood. When the Forge was established, he procured the first casting, which was the famous old iron pot, which he preserved as a curiosity, and it has been handed down in the family ever since."

Many of the seaboard towns of New England, situated on the drift and tertiary deposits, contain, or are environed by, lakes and ponds, at the bottom of which are deposited, by the water which has drained through the surrounding hills, large quantities of bog ore. This forms amorphous masses, or is crystallized into compact hydrate. The deposits, when removed, are renewed, at intervals of twenty or thirty years, by the process just described. Furnaces and forges, for smelting and working up the metal with charcoal from the neighborhood, were once quite numerous in Plymouth County, Mass. When the wood or ore became exhausted, and cheaper pig-iron from the coal regions of Pennsylvania rendered smelting in these localities no longer profitable, they were abandoned. These ores were readily fused, and when combined with silicious ores, produced very good castings. Sea shells were used as flux.

James and Henry Leonard were the first to commence the manufacture of iron, in Bristol County, Mass., building at Rainham the first forge in America. Henry soon removed to New Jersey, where he settled, while James lived and died in Rainham.

Vanderdonck, a Dutch historian of New Netherlands, says that about this time the people of New England cast their cannon, plates, pots, and cannon balls in iron from native ores.

Mallison, who claimed to be the sole promoter of the manufacture of hollow-ware, such as pots, kettles, etc., in *sand moulds*, petitioned the legislature, in March, 1739, for a grant of unimproved land. He claimed that the province "saved annually twenty thousand pounds importations," and in acknowledgment of his claim the General Court allowed him 200 acres (80.8 hectares) of unimproved land.

Jeremy Floris, an ingenious Englishman, introduced the art of casting in sand, in place of clay moulds. He practiced

the improvement in Kingston. Here the first experiments in smelting with anthracite coal are said to have been made.

38. New England Iron Works.—In 1731 there were in New England six furnaces for hollow-ware, and nineteen forges or bloomeries making bar iron, one slitting-mill, and a manufactory of nails. At that time there were no blast furnaces, nor any refineries of pig metal. Refineries came in use within the succeeding fifteen or twenty years. Three-quarters of a century later these furnaces were principally supplied from the New Jersey ore beds. With the pine wood of the neighborhood, about one and a half cords (5.4 cubic metres) were required to make 100 bushels (3.5 cubic metres) of charcoal. Six men could make 200 loads in three months. An acre of well timbered land yielded about 20 loads. The price paid on delivery at the furnaces was 15 to 20 shillings for a load of 80 bushels (2.8 cubic metres). One hundred and twenty bushels (4.2 cubic metres) smelted a ton (1,016 kilogrammes) of pig-iron. At each furnace eight or ten men were employed besides laborers.

In 1804, furnaces were about 20 feet (6 metres) high and 8 feet (2.4 metres) diameter at the boshes. Two huge bellows, 22 feet (6.6 metres) long and 4 (1.2 metres) wide, furnished the blast, and were worked by a water-wheel 25 feet (7.5 metres) in diameter. The furnaces were kept in blast 16 or 18 weeks. Two or three blasts were made in six months, yielding 200 tons (203,200 kilogrammes) of hollow-ware and other castings.

The expenses per annum were nearly the following on a product of 360 tons :

2,000 cords (7,240 cubic metres) of wood converted into 1,400 loads of charcoal, @ \$2.50	\$3,500.00
725 tons (736,600 kilogrammes) of ore, @ \$6.00	4,350.00
2 sets of hearth stone	150.00
Paid the founder \$1.00 per ton (1,016 kilogrammes)	360.00
Paid workmen \$6.50 per ton (1,016 kilogrammes)	<u>2,340.00</u>
Total	\$10,700.00
Cost per ton at the furnace, \$29.78.	

The first rolling and slitting mills in New England were erected at Middleboro, at very nearly the date, 1749, of the act of Parliament "to encourage the Importation of Pig and Bar iron from His Majesty's colonies in America; and to prevent the erection of any Mill or other engine for Slitting or Rolling of Iron, or any Plating Forge to work with a Tilt Hammer, or any Furnace for making Steel in any of said colonies."

In 1798 Plymouth and Bristol counties had in operation fourteen blast and six air furnaces, twenty forges and seven rolling and slitting mills, and many nail and smith shops.

The furnaces are said to have produced 1,500 to 1,800 tons (1,524,000 to 1,828,800 kilogrammes) of iron ware; and the forges upward of 1,000 tons (1,016,000 kilogrammes) of bar iron per year. The mills produced about 1,500 tons (1,524,000 kilogrammes) per annum.

Several rich beds of magnetic ore occur in the Connecticut valley. Some contain over 80 per cent. of the sesquioxides and peroxides. Attempts to smelt them at the end of the eighteenth century were not entirely successful.

Berkshire County contains some of the most valuable iron ores of Massachusetts. The beds of brown hydrate of iron are numerous and extensive throughout the county, at the edge of the lower Silurian limestone. This ore is frequently fibrous and concretionary, but often it is compact, and frequently occurs as red or yellow ochre. The most abundant deposits, wrought in open quarries, are in the towns of West Stockbridge, Richmond, and Lenox, and in Great Barrington and Pittsfield." These ores contain from 35 to 50 per cent. metallic iron.

For many years, several cold-blast charcoal furnaces have been engaged in making superior forge iron of the "Salisbury brand," as the ore is similar to that of the well known Salisbury mines in Litchfield County, Conn. Production is now limited by the scarcity of charcoal. Hot blast and anthracite coal are now adopted in furnaces making high-grade foundry iron.

The Lenox Iron Works Company built in 1765 their charcoal hot-blast furnace. The first forges in Rhode Island were

built in the towns bordering on Bristol County, Mass. Pig-iron and a variety of castings were the chief product, the ore not being much used for making malleable iron and steel.

One of the largest masses of magnetic oxide in New England is found in Cumberland, R. I. Although early discovered, and adapted to the manufacture of malleable iron and steel, it was, and is still, worked but intermittently.

In 1735, Samuel Waldo erected a furnace and foundry on the Pawtucket River, in the town of Scituate, which place is still well known as Hope Furnace. Naval ordnance, large bells, and a variety of other castings were made here during the War of the Revolution. The ore bed was four or five miles from the furnace in the channel of a small stream. A few years after the war, a steam engine was constructed at this furnace by Joseph Brown, of Providence, R. I., to drain the shaft.

Manufacturing bar and sheet iron, steel, nail-rods, nails, farming implements, stoves, and other castings, household utensils, anchors and bells, formed the principal industries of this State, at the end of the last century. Two slitting and rolling mills, three anchor forges, two nail-cutting machines, and several other establishments, driven by water-wheels were erected at Pawtucket Falls at this period.

At Salisbury, Conn., a bed of brown hematite ore, which is still worked, was explored as early as 1732. Two years after, Philip Livingstone, of Albany, N. Y., with others, started a furnace or bloomery smelting this ore, at Limerock, five miles from the ore bed. Pig-iron and various castings were made there in 1736. In 1762, a Mr. Hazleton built a blast furnace in Salisbury. This furnace was rebuilt in 1770, and in 1831 it was the oldest in the vicinity.

It produced annually from 500 to 600 tons (508,000 to 609,600 kilogrammes) of pig-iron. A third furnace was built in 1805. During the first half century, 2,000 tons (2,032,000 kilogrammes) of ore were raised annually.

The excellence of the ore, and the strength of the iron produced from it, gave Salisbury a reputation which it still retains. Ordnance and supplies were cast there during the Revolutionary War.

In the beginning of this century, between four and five tons of ore were raised annually from the great bed at Ore Hill. The Salisbury furnace was generally kept in blast four or five months in each year, producing from 18 to 20 tons (18,288 to 20,320 kilogrammes) of iron per week.

Iron was manufactured in 1761 from a black iron-sand found on the coast, and much interest was awakened in America and England.

Rev. Jared Eliot, of Killingworth, first succeeded in making iron from the magnetic iron sands of New England, and the gold medal of the Society of Arts was awarded him for the discovery in 1764. Wootz, or East Indian steel, is made by the Hindoos from a similar iron sand in clay furnaces.

39. Iron Making in the Middle States.—In 1750, iron ore was discovered in the town of Monroe, N. Y., at the south end of Sterling mountain. A year later, the first charcoal blast furnace was erected in Warwick. These works, called the Sterling Iron Works, were built for the manufacture of anchors. A forge was built at Monroe, near the furnace, where anchors are said to have been made. From 500 to 1,000 tons (508,000 to 1,016,000 kilogrammes) of ore were taken yearly from the Sterling mine, and an aggregate of about 140,000 tons up to 1842 (142,240,000 kilogrammes). Before and during the Revolution, about 1,500 tons (1,524,000 kilogrammes) of pig-iron were made here. Of this, 1,000 tons (1,016,000 kilogrammes) were made into bar. Mr. Peter Townsend made anchors at this place in 1773, and in 1776 he produced the first steel in the province, first from pig, and later from bar iron, by the German method. The first blister steel made in the State was made by Peter Townsend, Jr., in 1810. The first cannon was cast by Mr. Townsend in 1816. The great iron chain stretched across the Hudson, near West Point, in 1778, was forged at these works. It weighed 186 tons (188,976 kilogrammes), and was made in six weeks, under the inspection of Col. Timothy Pickering. The links of this chain weighed 140 pounds (63 kilogrammes) each. Some are still preserved among the revolutionary relics at Newburgh on the Hudson, and at New York.

The first large *steam cylinder* made in America was cast at the foundry of Sharp & Curtenius, in New York, for the steam engine of the water-works then under construction.

When the Champlain Canal furnished an outlet to the Adirondack region, the first furnace of the Adirondack Iron and Steel Company was erected. A blast furnace with forge fires and a puddling furnace were added, and a good business was done. The iron made was remarkably well adapted to the manufacture of nails and steel.

The manufacture of *cast steel* was first successful in this country at the Adirondack Steel Works of this company, in Jersey City. Specimens of steel and of the iron from which it was made received the premium at the London International Exhibition of 1851.

Rich veins of magnetic oxide and brown hematite ore are also found in New Jersey, and the earliest iron works in that State were situated in Shrewsbury, in Monmouth County. Morris County also contained an abundance and a great variety of ores. At the end of the eighteenth century ten mines were worked in Morris County. Two furnaces, three rolling and slitting mills, and about forty forges having from two to four fires each, were then in operation. In 1855 there were over eighty iron mines within the four counties of Sussex, Passaic, Morris, and Warren. Mining was commenced at Clinton over a century and a half ago, supplying the Union Furnace before and during the Revolution. Steel was made at Trenton, in 1776.

A charcoal furnace was built, in 1743, at Oreford, Warren County. It was 8 feet (2.4 metres) in diameter of bosh, and 38 feet (11.4 metres) in height. It produced, in 1857, 900 tons (914,400 kilogrammes) of iron, nearly all of which was made into car-wheels on the spot. The ore was obtained from a mine half a mile distant, opened in 1743, yielding rich magnetic ore. At Andover, in Sussex County, forty miles from New York, a mine of magnetic ore was opened and a blast furnace erected before the war. The bar-iron produced was of a superior quality. Iron from this furnace was sent to

England and there made into steel, and it was pronounced equal to the best Swedish and Russian metal.

Mr. Hewitt obtained a title to this mine in 1847, which had then remained a long time unworked. He began iron making later with Peter Cooper, Esq., of New York, and his son, Edward Cooper. Under their direction the manufacture of iron from these ores became one of the most extensive in the country.

The first experiments with the Bessemer process in this country were made at their works in 1856, and at their Trenton Rolling Mill the first wrought-iron beams for fire-proof buildings are said to have been made.

The manufacture of iron was attempted at Franklin, from Franklinite ore, just before the Revolution. The attempt, however, did not prove a success, in consequence of the presence of zinc and manganese. The Franklin Furnace was built in 1770. Mr. Edwin Post, at Stanhope, made iron from the same ore by a Catalan forge, which iron was found to have a superior tenacity.

The swamps and low grounds of New Jersey contain large quantities of bog iron ore. Several furnaces were erected, during the last century, for smelting these ores with charcoal, but they were either given up or converted into foundries after the anthracite iron manufacture was introduced.

The mineral deposits of Pennsylvania and the adjacent coal beds offered great advantages for the manufacture of iron, and were utilized at an early date. In 1683 William Penn mentions "Mineral of Copper and Iron in divers places" in the Province, and Gabriel Thomas, in 1698, describes the rich deposits of iron ore.

In Newcastle County, now the State of Delaware, a deposit of iron ore exists called Iron Hill, near which iron works were erected during the administration of Sir William Keith, 1717 to 1726. The first iron manufactured in Pennsylvania was probably made in Coventry Township, Chester County, about 1720. In 1728 there were four furnaces in blast in Pennsylvania. The Warwick Charcoal Blast Furnace was built in 1736, and in 1776 this, with the Reading Furnace,

were casting cannon for the State. These furnaces, when in blast, made 25 to 30 tons of iron per week. In 1780 pig iron was quoted at £300 Continental currency. In 1789 £6 10s. was paid in Pennsylvania currency, equivalent to \$17.33½. In 1800 pig metal was worth £10 per ton, or \$26.67⅓. Henry B. Grubb built the Mount Vernon Furnace in 1800. It produced 50 to 55 tons (50,800 to 55,880 kilogrammes) of iron weekly. The first rolling and slitting mill in Pennsylvania was built at Chester County in 1746. The earliest encouraging experiment in the employment of anthracite coal in the blast furnace, which gave a practical result, was made in the Pioneer Hot Blast Furnace at Pottsville, in Schuylkill County, Pa.

The first use of anthracite coal in a forge fire or grate was made at Wilkesbarre, in the Wyoming coal basin, as early as 1768 or 69.

The prosperity of Pittsburgh is chiefly due to the great bituminous coal seam in its vicinity, and to the abundance of iron ore in the adjacent counties. The Penns secured the coal beds in 1784. The first furnace was built in 1790, on the Youghiogeny by Turnbull & Co., who used the neighboring clay ores. A smelting furnace and foundry were built in 1804, in Pittsburgh, and a rolling mill in 1812.

In 1787 Thomas Paine conceived the project of employing iron for architectural purposes. A permanent bridge over the Schuylkill was proposed, to be built without piers, and Paine offered to build an iron bridge with a single arch of 400 feet span. It was, however, considered too hazardous, but Paine carried his plans into execution in France and England.

Robert Stephenson, the eminent civil engineer, speaking of the bridge over the Wear, erected at Sunderland, in 1794, and partly composed of the remains of one by Paine, said "we wonder at rather than admire a structure which, as regards its proportions and the small quantity of materials employed in its construction, will probably remain unrivalled."

Iron works were built at an early date in Delaware, smelting the bog ores. Governor Keith, of Pennsylvania, had iron works in Newcastle County, in 1726. Iron and castings were

manufactured in Sussex County before 1776. Maryland and Virginia sent their first samples of iron to England in 1718. In 1719 the Legislature of Maryland granted 100 acres (40.4 hectares) of land to any who would erect furnaces and forges in the Province. Eight furnaces and nine forges were erected within the next generation.

40. Later Statistics.—Mr. Wells states that the manufacture of iron in the United States may be divided into two periods, the first dating from the settlement of the country to the end of the year 1862; the second from 1863 to 1873. Its growth during the first period was gradual but steady; while during the second there was a very marked change in its rapid increase, owing to the war and also the extensive construction of railroads.

Before the Revolution pig and bar iron were among the regular exports of this country, and after the war the progress of this industry was very rapid. About the year 1791 we find it recorded that "a dangerous rivalry to British iron interests was apprehended in the American States not only in the production of rough iron, from the cheapness of fuel and quality of the iron, but also in articles of steel cutlery and other finished products, from the dexterity of the Americans in the manufacture of scythes, axes, nails," etc.

In 1810 the quantity of bar-iron produced was estimated at 40,000 tons (40,640,000 kilogrammes), against about 9,000 (9,144,000 kilogrammes) imported. There were 153 furnaces producing 53,908 tons of iron (54,770,528 kilogrammes), and 4 steel furnaces producing 917 tons (49,424,636 kilogrammes) of steel.

Iron manufactures were greatly crippled during the year which followed the war of 1812, although not entirely interrupted, and in 1816 the total import of pig iron was but 329 tons (334,264 kilogrammes). By 1824 business had revived, and the product of this year exceeded 100,000 tons (101,600,000 kilogrammes), and in 1832 it was reported at 200,000 tons (203,200,000 kilogrammes).

In 1837 the first furnace for smelting with anthracite coal was built, and at the close of 1843 there were twenty.

In 1835 iron began to be extensively employed for rail-

roads, and during that year 465 miles of road were constructed, and, in 1838, 416 miles (637 kilometres); in 1840 516 (825.6 kilometres), and, in 1841, 717 (1,147 kilometres).

The following figures indicate the progress of the pig-iron industry :

In 1850, 564,755 tons; in 1860, 919,770; in 1870, 1,865,000; in 1880, 3,835,191; in 1885, 4,044,525; in 1900, 13,789,242.

The production of cast steel in the United States, in 1872, was 40,000 tons, and, in 1881, 89,762 tons.

In 1868 the production of Bessemer steel was 8,500 tons; in 1899, about 10,700,000. The total annual product of this department, in the manufacture of rails for railroads, is as follows. Iron rail-making ceased about 1884.

TOTAL RAIL PRODUCTION IN THE UNITED STATES.

1849.....	24,314	tons.....	24,703,024	kilogrammes.
1860.....	205,038	tons.....	208,318,608	kilogrammes.
1870.....	620,000	tons.....	629,920,000	kilogrammes.
1880.....	1,461,837	tons.....	1,351,365,120	kilogrammes.
1900.....	2,550,000	tons.....	2,600,000,000	kilos, nearly.

The total consumption of iron was estimated, in 1840, at about 40 pounds (18.18 kilogrammes) *per capita*; in 1846 at 60 pounds (27.24 kilogrammes); in 1860 at 64 pounds (29.09 kilogrammes); and in 1890 at 300 pounds (136 kilogrammes).

The *per capita* consumption of Great Britain and of Belgium, for 1867, was 189 pounds (85.9 kilogrammes); and of France 69½ pounds (31.51 kilogrammes).

For the year 1872 the consumption of iron in the United States *per capita* was estimated at 150 pounds (68.2 kilogrammes), and that of Great Britain at 200 pounds (90.9 kilogrammes). In 1900 this figure was about 400 for the U. S.

CHAPTER IV.

THE ORES OF IRON.

41. **The Ores of Iron** are almost exclusively oxides and carbonates of varying degrees of purity. Ores cannot properly be so called when containing less than 25 per cent. of iron. For special purposes, the compounds of iron with sulphur and other elements are sometimes, though infrequently, utilized.

Ores of iron are distributed in great variety throughout every quarter of the world and in the deposits of nearly every geological age, but principally, and in the greatest purity, among the older rocks. The Huronian and Laurentian systems of North American rocks, the metamorphic rocks of Sweden and Norway, the Devonian deposits in England and the north of Europe, the rocks of Spain, Sardinia, and northern Africa, and the carboniferous limestones of the northwest of England, are all yielding ores of great richness and purity. The carboniferous deposits offer, in many localities, excellent ores heavily charged with combustible material.

The Oolitic ores are often worked, but usually contain a serious amount of phosphorus.

The United States are very rich in iron ores, and deposits are found in nearly every State.

The State of Michigan, on the borders of Lake Superior, contains immense deposits of very rich and pure ores; quite as valuable ores are found near Lake Champlain, in New York; and the State of Missouri is equally fortunate in the possession of deposits near St. Louis, which are not excelled by any known ores. New England, New York, New Jersey, Pennsylvania, and the whole range of the Alleghanies, in fact, extending to the Gulf of Mexico, contain large, accessible,

and valuable beds. The States of Ohio, Illinois, and Indiana are underlaid, in many places, by iron ore, and every year brings to light new deposits and sees new workings established.

The Atlantic coast of the United States is the water-shed of the Alleghanian range of mountains, and consists of primary rocks. The Mississippi valley and the interior of the country generally is underlaid by the secondary formations, while the tertiary rocks border the former.

The Ores of Iron are classified by the geologist as :

- (1.) Primary—Magnetic, Specular, and Red Hematite.
- (2.) Brown Hematites.
- (3.) Fossil Ores—from the Upper Silurian.
- (4.) Carbonates—usually from Coal measures.
- (5.) Bog Ores—of recent origin.

The mineralogist classes the ores as follows :

TABLE XIV.
MINERALOGICAL CLASSIFICATION OF ORES.

ORES.	CRYSTALLINE FORM.	COLOR OF POWDER.	HARDNESS.	SPECIFIC GRAVITY.
<i>Ferric Oxide—Red Hematite.</i>				
Hematite	Hexagonal	{ Cherry red to red- dish brown	5.5-6.5	5.5-5.3
<i>Ferric Oxide Hydrated—Brown Hematite.</i>				
Limnite	Massive	{ Yellowish brown } to rusty yellow	5-5.5	3.6-4
Xanthosiderite.	Massive or fibrous.	Ochre yellow	2.5	
Limonite	Massive or earthy.	Yellowish brown ..	5-5.5	3.6-4
Göthite	Orthorhombic ..	{ Brownish to ochre } yellow	5-5.5	4-4.4
Turgite	Massive	Reddish	5-6	3.5-3.7
<i>Ferrous Carbonate—Spathic Ore.</i>				
Siderite	Hexagonal	White	3.5-4.5	3.7-3.9
<i>Magnetic Oxide—Magnetite.</i>				
Magnetite	Isometric	Black	5.5-6.5	4.9-5.2

The chemical structure is as follows:

ORES.	FORMULA.	PER CENT. METALLIC IRON.	WATER.	CARBONIC ACID.
Hematite	Fe_2O_3	70.00		
Limnite	$\text{Fe}_2\text{O}_3, 3\text{H}_2\text{O}$	52.34	25.23	
Xanthosiderite	$\text{Fe}_2\text{O}_3, 2\text{H}_2\text{O}$	57.14	18.37	
Limonite	$2\text{Fe}_2\text{O}_3, 3\text{H}_2\text{O}$	59.90	14.43	
Göthite	$\text{Fe}_2\text{O}_3, \text{H}_2\text{O}$	63.03	10.11	
Turgite	$2\text{Fe}_2\text{O}_3, \text{H}_2\text{O}$	66.28	5.33	
Siderite	FeO, CO_2	48.27	37.93
Magnetite	Fe_3O_4	72.41		

There are also two species of native iron—iron found naturally in metallic form. These are meteoric and telluric iron; the former is found occasionally in all parts of the earth's surface, and the masses discovered vary in size from several tons weight to that of fine grains, and even powder; the second is found in but two or three places on the earth's surface, imbedded in rocky strata.

The characteristics of these several forms of minerals are widely different mechanically, physically, and chemically.

42. Meteoric Iron resembles closely, in all its characteristics, the artificially produced metal which will be minutely described in the proper place. It often forms a part of earthy meteorites, but is usually found isolated or only alloyed with nickel and with a trace of other elements. The largest masses have been found in Siberia, Mexico, and South America.

A meteoric iron from California, analyzed by Cairns gave the following:

Iron.....	81.480	Calcium.....	0.163
Nickel.....	17.173	Carbon.....	0.071
Cobalt.....	0.604	Silicon.....	0.032*
Aluminum.....	0.088	Phosphorus.....	0.308
Chromium.....	0.020	Sulphur.....	0.012
Magnesium.....	0.010	Potassium.....	0.026
Total.....			99.987

Aluminum, calcium, and potassium have seldom been found in meteoric iron. Manganese and copper, usually present, are here absent.

Watts gives the following analyses of meteoric iron from widely separated localities. The supposed extra telluric origin of this material is also indicated by this similarity.

TABLE XV.
ANALYSES OF METEORIC IRON.

FELL AT	BOHUMILITZ, BOHEMIA, IN 1829.	KRASNO- JANSK, SI- BERIA.	HRASCHINA, CROATIA, 1751.	CAPE AFRICA.	CLAIRBORNE, ALABAMA.	POTOSI.	NORTH AMER- ICA.	BITBERG, NEAR TREVES.
WEIGHT.	103 lbs. 46.76 kilos.	1600 lbs. 726 kilos.	71 lbs. 32.23 kilos.	500 lbs. 136 kilos.				3300 lbs. 1498 kilos.
ANALYST.	Berzelius.		Wehrle.		Jackson.	Mowen.	Silliman and Hunt.	Stromeyer.
Iron.....	93.78	88.04	89.78	85.61	66.56	83.57	92.58	81.8
Nickel.....	3.81	10.73	8.89	12.27	24.71	12.67	5.71	11.9
Cobalt.....	0.21	0.46	0.67	0.89	1.0
Copper.....	0.07	trace.
Manganese....	0.13	3.24	0.2
Chromium.....	trace.
Tin.....	trace.
Magnesium....	0.05
Arsenic.....	trace.
Sulphur.....	trace.	4.00	5.1
Iron sulphide..	2.30
Carbon.....	0.04
Chlorine.....	1.48	0.91
Insoluble.....	2.20	0.48	1.40
	100.00	100.00	99.34	98.77	99.99	99.45	99.69	100.0

The color of meteoric iron is very like that of platinum; the surfaces of the masses are usually somewhat oxidized.

43. **Telluric Iron** is exceedingly rare. It is found in plates and grains, and has a specific gravity of from 7 to 7.8. It exists in a thin vein, reported as two inches (5.08 centimetres) thick, at Canaan, Connecticut, in mica slate, and there con-

taining 91.8 per cent. iron with 7 per cent. carbon. This is properly a "cast iron." It is found at Grenoble in brown hematite and quartz, and in South America associated with platinum, and in some other places. It has been stated by Wöhler to occur usually in the "passive state," possessing no observable chemical affinity.

44. **Magnetic Iron Oxide**, Fe_3O_4 , *Magnetite*, or the *Magnetic Ore of Iron*, is the richest, and usually the purest, of the ores. It contains, when purest, 72.41 per cent. metallic iron. It is usually black in color, has a defined crystalline form, is strongly magnetic and very coherent, and its masses are usually homogeneous in character and compact. The most characteristic form of this ore is known as "loadstone," or "lead-stone," from its power of producing artificially magnets and endowing the compass needle with its peculiar powers. This quality is said to have been first noted at Magnesia in Asia Minor, from which place the name is derived.

The magnetic ore occurs in extensive deposits in the United States, in Sweden and Norway, and in Siberia. Its specific gravity varies from 4.9 to 5.1. It often occurs as a black sand containing some titanate acid; more usually it forms large deposits, and even mountain masses. It is very widely distributed in the United States. Excellent Magnetites are found in New York State, New Jersey, New England, and in the State of Michigan. They exist in North Carolina in extraordinary purity, rivaling the celebrated Danemora ore of Sweden.

It furnishes iron of excellent quality, and all of the best steels in the world are made from this ore. The celebrated "Wootz" steel of India is made from an "iron sand" composed of finely divided magnetite. It is sometimes, however, seriously contaminated with sulphur and with phosphorus, from the iron pyrites and the phosphate of lime which accompany it.

Franklinite, $3(\text{FeO}, \text{ZnO}, \text{MnO}) + (\text{Fe}_2\text{O}_3, \text{Mn}_2\text{O}_3)$, a celebrated New Jersey ore, is a magnetite containing 45.16 per cent. iron, with zinc and manganese oxide, which have replaced

ferric oxide. It is worked for the zinc, and the iron oxide remaining is then reduced, and a metal rich in manganese known as "spiegeleisen" is obtained. The preceding analyses of magnetic ores of the United States give a very complete exposition of their character.

Foreign magnetic ores have, according to Watts, the following composition :

TABLE XVII.

ANALYSES OF EUROPEAN MAGNETIC ORES.

SOURCE.	DART-MOOR.	CORNWALL.		ROSEDALE.		DANNE-MORA.
ANALYST.	Riley.	Noah.		Northcutt.	Pattinson.	Karsten.
Ferric Oxide	62.20	44.40	66.50	12.22	32.67	70.23
Ferrous Oxide.....	17.32	20.00	13.00	35.25	33.85	29.65
Manganous Oxide ..	0.14	0.16	0.56	0.69	
Alumina	3.81	5.20	3.60	14.10	3.15	
Lime.....	5.52	0.60	0.56	2.38	2.86	
Magnesia.....	1.82	1.00	1.52	3.95	1.59	
Potash and Soda....	0.10	trace	
Silica.....	9.66	9.65	6.95	
Carbonic Acid.....	16.25	10.36	
Phosphoric Acid....	0.10	0.50	0.57	1.41	
Sulphuric Acid.....	0.04	0.04	trace	trace	
Iron Pyrites.....	0.07	trace	0.03	
Water { combined ..	0.28	} 2.50	} 3.20	} 4.80	} 3.76	
{ hygroscopic.	0.34					
Insoluble in acid	24.20	9.40	0.84	
	101.36	98.60	98.95	98.60	98.16	99.88
Metallic Iron.....	57.01	35.94	49.17	71.68

45. **Red Hematite**, Fe_2O_3 , the native ferric oxide, sesquioxide or peroxide, is nearly as rich an ore as the magnetite ; it contains 70 per cent. metallic iron and 30 per cent. oxygen, and is anhydrous when pure. It is found in various forms, as massive, granular, crystalline, or earthy. Red hematite occurs also in large veins or beds, and frequently is associated with silica in the form of quartz, and with spar. Red ochre

is an earthy variety of this ore. Specular ore, iron glance, micaceous ore, is a crystallized variety of the red hematite with a crystalline structure, and often with beautifully splendid and iridescent facets. Its usual color is a very dark gray approaching black. Its crystals are of the hexagonal system.

Specular ore frequently contains titanium and manganese, which partially replace the iron and form thus the titaniferous and manganiferous ores. The presence of these elements is indicative of the absence of injurious elements, and they probably are also of direct advantage. They, however, render the ore less readily fusible. The compact, fibrous, and columnar forms are most common. The red hematites are distinguished by their bright red color when scratched.

These ores are, as a class, of great purity, and furnish the makers of cast iron for Bessemer works with nearly all their raw material.

Red hematite ores are very widely and plentifully distributed. They are found in the Lake Superior (Marquette) mining region, at the Iron Mountain and neighboring deposits in Missouri (Iron Mountain, Pilot Knob, Shepherd Mountain); in northern New York and in New England; in Canada and Nova Scotia; and in many other localities in North America. A very fine deposit exists in the Cumberland district, in England; in North Lancashire; in Ireland; and in Glamorganshire, Wales. Large deposits are worked in Northern Europe, especially in Scandinavia. Bona, Algeria, has mines of very pure ore, which supply the Bessemer works of England and Continental Europe. The following analyses of ores found in the United States, belonging to this class, is also useful as indicating the composition of the red hematite of other portions of the world. The richness and purity of these ores is well exhibited by comparing their composition with the analyses given in the other tables contained in this chapter. They make the finest malleable irons. Wrought iron made from them is remarkable for its strength and ductility.

The following are analyses of some celebrated European ores, as given by Watts :

TABLE XIX.
ANALYSES OF EUROPEAN RED HEMATITES.

SOURCE.	WHITEHAVEN.		ULVERSTONE.		CLEATOR.	ULVERSTONE.	WHIT-CHURCH, SOUTH WALES.
	Analyst.	W. A.	Dick.	Spiller.	R. Smith.	Dick.	
Ferric oxide.....	98.71	95.16	94.23	90.94	90.55	86.50	66.55
Ferrous oxide.....	1.13
Manganous oxide....	trace.	0.24	0.23	0.25	0.10	0.21	1.13
Alumina.....	0.06	0.63	trace	1.43	0.30	2.79
Lime.....	trace	0.07	0.05	0.99	0.71	2.77	9.40
Magnesia.....	trace	trace	0.06	1.46	1.39
Potash.....	0.42
Soda.....	0.15
Silica.....	1.00	5.66	4.90	6.68	7.05	6.18	8.90
Carbonic acid.....	0.78	2.96	5.73
Phosphoric acid.....	trace	trace	trace	trace	trace	trace	1.02
Sulphuric acid.....	trace	0.09	0.24	trace	0.11	1.31
Iron pyrites.....	trace	0.03
Water { hygroscopic.....	0.39	} 2.12
Water { combined	0.17	
Organic substance...	0.38
	99.71	101.19	100.72	98.88	99.90	100.49	102.42
Metallic iron.....	69.10	66.60	65.98	63.66	63.25	60.55	47.47

46. **Brown Hematite, Hydrated Hematite, Hydrated Ferric Oxide,** $2\text{Fe}_2\text{O}_3 + 3\text{H}_2\text{O}$, contains, when pure, 85.6 per cent. ferric oxide and 14.4 per cent. water. In its various forms of brown ore, lake ore, bog ore, marsh ore, and ochre, it belongs to the more recent deposits, and is extremely abundant. All varieties of this ore contain a considerable proportion of water chemically combined, and very frequently a large amount of hygroscopic moisture, and the several varieties form a somewhat regularly graded series, terminating on the one hand with ores scarcely distinguishable from the red hematites, and on the other with earthy iron ores heavily loaded with water. The red streak of the red ores grades off in this series through brown to the yellow of the earthy ochres.

Turgite, which possesses least water, has a red streak closely resembling that of the red hematites. It also resembles the latter closely in structure and all physical properties.

Limonite, which is the usual form of brown hematite, contains, when pure, 59.92 per cent. metallic iron. It often contains some manganese, and is not infrequently seriously contaminated with phosphorus and sulphur, and intermingled with organic matters.

This ore is always, probably, of recent formation, and is derived from the more ancient ores by chemical and physical alteration, and from minerals containing iron, which is washed out and transported mechanically in flowing water to other localities, where it is precipitated in the hydrated form. It is by this process that the bog-ores are supposed to have been formed in recent times. Solution occurs where the metal may be taken up as a proto-carbonate, as a sulphate, or as the base of a salt produced by an organic acid. In its more compact forms it is found in large beds, in isolated masses, in stalactitic form, in distinct nodules, in fine grains, and in the condition of a powder. It can be distinguished by its brown or yellow streak, when scratched. In the United States, it is the most generally distributed of all the ores, and from it is produced the principal part of the varieties of foundry iron made. It is less well adapted for the manufacture of wrought iron, and is entirely unfit for making steel.

The brown hematite of Salisbury, Connecticut, of Berkshire, Massachusetts, of Dutchess and the adjacent counties in New York, and one or two deposits in Pennsylvania, are distinguished for their purity.

A line of deposits of this ore underlies the Alleghany and Appalachian chains of mountains from end to end, and the deposits which have long been worked in Alabama are of immense extent and great value.

This ore is found and worked in many localities in Ohio, Indiana, Kentucky, and Tennessee, and exists also in Arkansas, Colorado, Montana, New Mexico, and Texas. Large deposits exist in Canada, and on the Continent of Europe. It is extensively worked in France, and the ores of the mining

TABLE XX.
ANALYSES OF BROWN HEMATITES OF THE UNITED STATES.

SOURCE.	FISCAT- COUNTY, MAINE.	YORK COUNTY, PENNSYLVANIA.	CENTRE COUNTY, PENNSYLVANIA.	LIME- STONE COUNTY, ALABAMA.	FIB- ROUS BROWN HEMATITE, ALABAMA.	FERRY COUNTY, INDIANA.	PUTNAM COUNTY, WEST VIRGINIA.			WASHING- TON COUNT- Y, TEN- NESSEE.	BERK- SHIRE COUNTY, MASSACHU- SETTS.	OSAGE COUNTY, MISSOURI.	SALISBU- RY, CON- NECTI- CUT.	HARDIN COUNTY, ILLINOIS.	
							Bed No. 1.	Bed No. 2.	Bed No. 3.						
Analyst.	Leeds.						Owen.	Whittlesey.			Fisher.	Jackson.	Leeds.		
Ferric Oxide.....	76.87	47.49	81.55	80.65	82.82	69.5	0.25	2.50	0.42	82.27	70.0	77.42	81.13	81.22	
Manganic Oxide	4.32	0.10	0.26	0.77	0.25	0.27	4.0	0.60	
Manganous Oxide	
Silica.....	0.71	26.70	4.53	0.29	16.35	8.84	7.42	3.05	8.05	3.68	0.145	
Alumina.....	7.34	1.49	0.09	0.35	3.00	1.28	9.3	1.68	
Lime.....	1.67	trace	trace	trace	6.08	0.20	0.7	
Magnesia.....	0.25	0.47	trace	3.5	
Water.....	19.25	8.90	11.70	12.37	14.62	8.0	9.71	10.56	13.15	12.0	12.49	13.81	11.46	
Phosphoric Acid .	0.10	2.67	0.16	0.92	0.15	0.90	0.17	0.09	0.176	trace	
Sulphuric Acid .	3.10	
Sulphur.....	0.24	0.203	0.147	trace	
Insoluble matter	5.58	16.0	4.3	
Ferrous Oxide...	trace	
	100.03	99.58	100.00	99.87	99.00	100.0	100.313	91.0	98.283	108.52	97.660	
Metallic Iron.....	56.45	57.97	48.6	58.10	50.15	56.80	57.6	55.3	

districts of the Rhine, of Carinthia, and Styria, are of excellent quality, and furnish large quantities of good iron. In Great Britain it is worked in Cumberland, Devonshire, Durham, Gloucestershire, Northamptonshire, and Lincolnshire. The celebrated "lake ores" of Sweden are of this class. They are collected by dredging in the Swedish lakes.

Yellow ochre is a strongly hydrated hematite, and umber is a somewhat similar variety of this ore, containing oxide of manganese.

TABLE XXI.

ANALYSES OF BROWN HEMATITES OF EUROPE.

SOURCE.	DEAN FOREST.			DEVON- SHIRE.	NORTHAMP- TONSHIRE.		WEARDALE.	
	Dick.		Price.	Dick.	Dick.		Tookey.	Spiller.
Ferric Oxide	90.05	89.80	89.28	89.39	76.00	74.32	72.08	49.57
Ferrous Oxide	trace	10.77
Manganous Oxide..	0.88	0.04	0.33	0.40	0.57	6.60	3.06
Alumina	0.14	0.98	0.52	2.30	2.91	0.40	0.84
Lime	0.06	0.51	0.33	0.41	0.76	0.56	5.69
Magnesia	0.20	0.40	0.20	0.11	0.18	1.90	1.21
Potash	0.05
Silica	0.92	2.14	0.98	1.42	5.33	6.03	4.09	6.64
Carbonic Acid	0.57	0.13	14.49
Phosphoric Acid . . .	0.09	0.13	trace	0.13	1.03	3.17	0.22	0.01
Sulphuric Acid	trace	trace	trace	trace
Iron Pyrites	trace	trace	0.06	0.03
Water } hygroscopic	9.74	8.83	1.80	12.40	1.81
Water } combined	9.22	7.05				11.89
Organic substance..	trace	trace
	101.60	101.05	100.00	101.15	99.78	100.46	98.38	100.80
Metallic Iron	63.04	62.86	62.57	62.60	53.20	52.05	49.78	43.02

47. *Spathic Iron Ore, Sparry Ore, Native Ferrous Carbonate Siderite*, FeO, CO_2 , consists principally of Ferrous Carbonate, and, when pure, contains 48.27 per cent. of metallic iron. A portion of the iron is almost invariably replaced by other elements, as lime, magnesia, or manganese. Its form is usually crystalline, the crystals having the same structure as those of calc spar, and often, in thin scales, translu-

cent and brilliant; it has a specific gravity of 3.7 to 3.8. In fibrous nodular masses it is known as Sphaero-Siderite. Its color grades from white to yellow and brown, and its chemical composition, on exposure to the air, is altered, the mineral becoming a brown hematite. It is frequently quite free from objectionable elements, and is the most generally valuable of all ores, not only because of its purity, but because the manganese and zinc found with it are of value in the processes of reduction. It has been called a "steel ore," from the fact that these peculiarities make it exceptionally valuable in the manufacture of all but the finest grades of steel. German steel is usually made from this ore, and it is the ore which supplies spiegeleisen for modern steel-making.

48. **Clay Iron Ore, Agrillaceous Ore, Clay Ironstone,** is of similar composition to the preceding, except that the carbonate is here mixed with the sedimentary formations, and especially of the coal measures. It is sometimes found in beds and sometimes in nodular masses, imbedded in clay. It is somewhat hard, has nearly the same range of color as the pure spathic ore, is of less density, and quite variable in composition and value.

Blackband Iron Ore is found in the coal measures, and consists of a clay ironstone largely intermingled with carbon, as bituminous coal. The proportion of carbon varies from a very insignificant amount to above twenty-four per cent. This admixture of carbon assists in reduction of the ore to an extent that is frequently of great economical importance.

The three classes of spathic ore just described yield not far from one-half of all the iron made in Great Britain. They are rarely worked in the United States.

These ores are, when calcined previous to smelting, changed into impure oxides by the elimination of the acid constituent, and usually lose about one-half their original weight. The spathic ores darken when roasted, becoming nearly black in consequence of the change into peroxide. They may pass through the condition of limonite and assume the character of red hematite. The carbonate ores have been found at a number of places in the United States. Siderite

exists at Roxbury, Connecticut, in several places in Pennsylvania, West Virginia, and in Ohio, Indiana, and Kentucky. The blackband ore of Washington Township, Indiana, has been stated to be the richest ore in that State, and the similar ores of Ohio give promise of becoming of great value. The carbonate ores of Pennsylvania, found in Scranton, are now worked, and at Laurel Hill, near the Conemaugh, they are found in large deposits.

TABLE XXII.

ANALYSES OF CARBONATE ORES OF THE UNITED STATES.

SOURCE.	FAYETTE COUNTY PENNSYLVANIA.	KENAWHA RIVER, WEST VIRGINIA.	SIDERITE, WESTERN PENNSYLVANIA.
Analyst.	Leeds.	Rodgers.	Leeds.
Ferrous oxide.....	45.27	22.44
Ferric oxide.....	0.64	81.11	8.95
Silica.....	11.24	29.76
Alumina.....	8.14	0.28	10.40
Lime.....	1.72	2.94
Magnesia.....	1.51	1.24
Water.....	0.03	11.10	2.62
Organic matter.....	0.95
Carbonic acid.....	30.32	17.34
Phosphoric acid.....	0.17	trace
Sulphur.....	trace	6.54
Manganous oxide.....	1.85
Potash and soda.....	2.46
Lithia.....	trace
	99.99	99.03	100.00
Metallic iron.....	56.77

The carbonate ores occur in Great Britain as spathic ore at Weardale, in county Durham, at Brendon, in Somersetshire, and in Devonshire. The clay ironstone is found in extensive deposits in Derbyshire, Staffordshire, Yorkshire, and in South Wales. The most important, commercially, are the beds of impure carbonate, or clay ironstone, obtained from the lias of the Cleveland hills of Yorkshire, and reduced in the smelt-

ing furnaces of Middlesborough-on-Tees and the adjacent towns. One seam of this ore is ten or twelve feet in thickness (3.3 to 4 metres). The yield here is about 20,000 tons per acre (60,190,400 kilogrammes per hectare); these ores have made the district wealthy, built up large towns, and the manufacture of low-grade, but cheap, iron has been carried on here in a manner that is remarkable for both a commercial and a metallurgical development elsewhere unequalled.

The British blackband ores are found most abundantly and in richest character in Lancashire, and Ayrshire in Scotland. The richest yield the best known brands of Scotch iron. They usually contain 15 or 20 per cent. of iron, but the proportion sometimes rises to 40 per cent.

The carbonates are found, of great purity and value, on the Continent of Europe, in Prussia, Styria, and Carinthia.

Blackband is found in Westphalia, but it contains a remarkably large percentage of phosphoric acid; this ranges from 20 to 50 per cent.

The carbonates are also found in some parts of France.

49. Iron Bisulphide, Iron Pyrites, FeS_2 , are not utilized as an ore of iron, although very abundantly distributed as a native iron bisulphide, a mixture of iron and copper sulphide, and in the several forms of yellow and white iron pyrites, magnetic pyrites, arsenical pyrites, in greater or less purity. The purest pyrites contain 53.33 per cent. of iron, and 46.67 per cent. sulphur. This material is used as a source of sulphur.

50. Chrome Iron Ore, Impure Chromate of Iron, Chromite, Fe_2O_3 , Cr_4O_3 , or $3FeCrCr_2MgAl_2Fe_2O_2$, is a somewhat abundant ore of iron and chromium, which has recently assumed some importance in making the "chrome-steels."

It occurs in serpentine masses in veins or beds, has a compact or granular structure, of dark brown or black color, giving a brown streak. It has a metallic lustre, is opaque, brittle, has a conchoidal fracture, and is sometimes magnetic.

It is found in the U. S. in Maryland, Pennsylvania, and N. Carolina, and in the Shetland Islands, Norway, Tuscany, Siberia, France, Austria, Syria, and many other parts of the

TABLE XXII.—ANALYSES OF EUROPEAN CARBONATES.

SOURCE.	EHREN-FRIEDERS-DORF, SAXONY.	MUSNER, STAHL-BERG, PRUSSIA.	ALTEN-STYRIA. (Cal-cied.)	BLACKBAND, SCOTLAND.	WESTPHALIA BEST BLACKBAND ROASTED.	SOURCE.	LOWHOOR, YORKSHIRE.	STAFFORD-SHIRE.		PONTYPOOL, SOUTH WALES.	MIDDLES-BRO.	NORTHAMP-TONSHIRE.
								Foley.	Dick.			
Analyst.	Magnus.			Colquhoun.		Analyst.	Spiller.	Dick.	Riley.	Percy.	Dick.	
Ferric oxide.....	67.22	0.33	7.704	Ferric oxide.....	1.45	0.12	0.50	2.86	3.31	
Ferrous oxide.....	36.81	46.22	4.69	38.80	54.715	Ferrous oxide.....	36.14	51.07	44.50	43.02	33.29	
Manganous oxide..	25.31	10.55	0.07	Manganous oxide..	1.38	2.36	0.73	0.40	1.11	
Manganic oxide....	3.36	0.934	Alumina.....	6.74	2.47	5.95	5.87	7.89	
Alumina.....	2.49	6.20	4.034	Lime.....	2.70	1.74	2.05	
Lime.....	0.75	1.25	5.30	4.643	Magnesia.....	2.17	1.10	3.26	5.21	11.77	
Magnesia.....	2.73	4.11	6.70	2.222	Silica.....	17.37	3.02	10.81	7.17	19.49	
Silica.....	1.08	12.49	10.80	20.532	Carbonic acid.....	26.57	33.03	30.92	25.50	24.79	
Carbonic acid.....	38.35	38.38	3.35	30.76	0.760	Phosphoric acid....	0.34	1.12	0.23	2.81	0.22	
Phosphoric acid...	trace	0.719	Iron pyrites.....	0.10	0.17	0.11	0.13	
Iron pyrites.....	Water { hygroscopic.	0.61	0.76	0.34	
Water.....	0.09	1.418	Water { combined...}	1.16	0.99	3.14	0.54	
Sulphuric acid.....	0.49	0.498	Sulphuric acid.....	trace	trace	trace	
Sulphur.....	0.16	Sulphur.....	0.04	
Organic substance..	1.87	2.941	Organic substance..	2.40	1.24	0.21	0.15	0.08	
						Potash.....	0.65	0.28	0.20	
						Soda.....	0.13	
						Zinc.....	5.14	0.50	
	100.47	99.80	99.45	100.06	101.120		99.78	99.31	100.16	100.61	103.36	
Metallic iron.....	28.63			30.00		Metallic iron.....	29.12	39.88	34.96	35.46	28.28	

world. It is only used as an important source of metal by the manufacturers of chrome-steel in the United States.

TABLE XXIV.

ANALYSES OF CHROME IRON ORES.

SOURCE.	BALTIMORE, MARYLAND.	BALTIMORE, MARYLAND, (Crystallized.)	LANCASTER COUNTY, PENNSYLVANIA.		VOLTERRA, TUSCANY.	BERESOFF, SIBERIA.
	Abich.		Franke.	Garrett.	Bechi.	Moberg.
Chromic oxide	55.37	58.25	55.14	63.38	44.23	59.80
Chromous oxide	1.61	4.39
Ferric oxide	1.10	12.06	0.33
Ferrous oxide	18.04	20.13	18.02	38.66	35.32	18.59
Alumina	13.97	11.85	5.75	20.83	10.93
Magnesia	10.04	7.45	9.39	6.74
Protoxide of nickel	2.28
	98.52	99.39	100.36	104.32	100.71	100.45

51. **Titaniferous Ore, Titanate of Iron, Ilmenite, $Fe_2Ti + Fe_2O_3$,** is an ore which is of common occurrence, usually associated with the peroxide of iron; it contains 36.82 per cent. iron. It is found crystalline and in the form of compact masses, and also as a titaniferous iron sand. It is a hard, heavy mineral, with submetallic lustre, dark gray to black color, with brownish red or black streaks, opaque, and with conchoidal fracture, and is slightly magnetic. It is very difficult to fuse.

A large mass of titaniferous ore exists at Cumberland, R. I., and it is found in Connecticut, New York, North Carolina, Pennsylvania, Vermont, and other parts of the United States and Canada.

It occurs in South America, in Norway and Sweden, Germany, Austria, and on the banks of the river Mersey.

The titaniferous ores are usually very free from phosphorus, and their use in the making of iron has been restricted merely by their refractory character. With the high temperature attainable with the hot blast they are reducible,

and have been very successfully worked in Norway, even when containing a somewhat large proportion of titanitic acid.

52. Wolfram, Tungstate of Iron, $\text{FeO}, \text{MnO}, \text{WO}_3$, is an ore of tungsten and iron which has given promise of value, like the chrome and titaniferous ores, by its property of giving peculiar and valuable qualities to iron obtained from it. Its structure varies like the preceding; it is hard, very heavy, has a metallic lustre, a dark gray or nearly black color, dark reddish-brown streak, is opaque, and sometimes slightly magnetic. It is found associated with ores of tin, of lead, and of bismuth, in the United States, in Great Britain, and on the Continent of Europe. Ores of iron containing wolfram have been used in the production of a peculiar kind of steel.

53. Artificial Ores are occasionally mixed with natural oxides or "mine" in the making of iron. The tap-cinder from puddling furnaces is often very rich in iron, although usually charged also with injurious elements which enter it from the iron in the puddling process. It has been used more commonly since the general introduction of the hot blast, which has enabled comparatively "lean" and refractory ores to be reduced in the blast-furnace. The "cinder-pig" thus made is not generally regarded as good or strong iron, but it possesses the advantage for some purposes of giving fluidity of the molten metal, and of making exceptionally sound castings—advantages due to the presence of phosphorus. It sometimes happens that blast-furnace slag is itself so rich in iron and so free from hurtful admixture of foreign elements that it is sent through the furnace again as a part of new charges.

54. The deleterious effect of the elements which are found united with the ferric oxide in iron ores is determined in amount, not only by their own nature, but by the proportions in which they occur, and by the proportions which they bear to each other.

In general, the value of an ore is determined, in this regard, by the effect of the element in producing change of quality of the metal. The iron is usually found to contain in greater or less degree all the elements originally present in the ore from which it was made.

In some cases, as with manganese and the metals of its class, a considerable portion is discharged from the ore into the furnace-slag and into the cinder of the puddling furnace, in other cases, as with phosphorus, it is extremely difficult to prevent all, or nearly all, passing into the iron. The effect of each of the more common elements, and those having most marked influence on the character of the iron, will be considered in the chapter on iron and its properties.

The presence of chromium, magnesium, manganese, and titanium in an ore gives it a higher temperature of fusion, and may, if in considerable quantity, render it so refractory as to be quite incapable of reduction in the smaller furnaces and in those having cold blast.

The presence of silica, lime, and alumina in the proportions hereinafter noted (Art. 89) as giving a satisfactory character of slag is an advantage. Any variation from these proportions is disadvantageous.

The presence of sulphur is seriously objectionable in most cases, but in very small quantity is not fatal, and manganese is also its antidote to a certain extent. The latter element is usually considered desirable in moderate quantity, as are the other metals of its class.

Phosphorus is usually considered the most hurtful of all known ingredients in ores, and it cannot, by any known process, be wholly removed. It has, however, been recently learned that good metal may be made from ores heavily charged with phosphorus when the proportion of carbon present is properly limited.

The effect of minute proportions of the elements present in ores has yet to be studied with such care, and investigated with such accuracy, as to determine satisfactorily the effect of foreign elements when present in minute proportions and when having mutually modifying influence.

The physical condition of the ore modifies its value in several ways:

(a.) Compact ores, if not extremely hard, can be readily broken into proper size for reduction. Friable ores are liable to become ground into fine powder, and thus to be subject to

loss in transportation and to give trouble in the blast-furnace. They should be mixed, when possible, with other ores.

(*b.*) The crystalline character of the ore is supposed by some experienced metallurgists and iron-makers to have some influence in determining the value of the metal produced from it. Steel makers sometimes select ores best adapted to the production of the finer grades by observing their crystalline structure. It has even been said that some similarity exists between the structural character of the steel and that of the ore from which it comes. Whether this, if true, is due primarily to simple crystallographic peculiarities, or to peculiarities of chemical constitution which produce such modification, is not known.

Volatile matters present in an ore are usually only injurious in consequence of adding to the cost of production by the expense of removing them. Incidentally, they sometimes afford an advantage by rendering the ore more open and permeable by the reducing gases after their expulsion.

55. The Value of an Ore depends upon :

- (*a.*)—Its qualitative chemical constitution.
- (*b.*)—The quantitative proportions of its components.
- (*c.*)—Its physical character.
- (*d.*)—The relation of cost of supply to the market price.

To determine the advisability of attempting to use any ore, therefore, the first step consists in the careful examination of the mineral to ascertain what is its composition and its character as a reducible ore.

The next step should be to examine the locality from which it is to be obtained, and to estimate the cost of working the deposit and of transportation to the point at which the ore is to be used.

The final procedure is to compare the data thus secured with those obtained by examination of competing ores and districts.

56. The Analyses of the Ore may be conducted by either the wet or the dry process. By the wet or "humid" method, it is usual to determine as accurately as may be desired the

chemical constitution of the ore, and to ascertain with greater or less accuracy the percentages of foreign elements present, and especially of those which exert most marked influence on the quality of the product. The details of the most approved methods are given in works on chemical analysis.

The metallurgist and the engineer usually send their specimens to a metallurgical chemist for this analysis. The chemist determines, with especial care, the proportions in which iron, silica, manganese, calcium, magnesium, sulphur, and phosphorus and moisture occur. Titanium is often looked for, and other elements are determined when it is expected that they may affect the character of the ore in any important degree.

57. The Dry Method, or Assaying, is practiced by both the chemist and the metallurgist. By the preceding process the exact quantity of any element existing in the ore may be determined; but it does not afford a means of determining, except by inference, the quality of the metal derivable from the ore. The dry process is analogous in its character to the operation of smelting, by which the iron is made, and it results similarly in the production of the metallic iron. It therefore permits a judgment to be formed of the character of the iron to be expected as a product of the smelting operation, and more directly of its commercial value. The process is a simple one, is conveniently carried on without the peculiar and cumbersome outfit of the laboratory, and it is therefore the process most practiced by the metallurgist and the engineer.

The assay-furnace usually resembles closely the furnace of the brass-founder. It consists of a fire-brick structure of rectangular horizontal section, and sufficiently large to take one or two crucibles. A furnace fifteen or eighteen inches square (38 to 45 centimetres) and twenty inches or two feet (51 to 61 centimetres) deep is a usual size. The fuel is coal or coke, or a mixture of both. The crucible should be carefully selected and of the best material. It is either mounted on a piece of brick or tile in the midst of the fire, or it is similarly imbedded in the burning fuel. A cover of fire-clay, or made of the same material as the crucible, is luted upon it.

The crucible is placed in the furnace and removed by means of tongs of convenient shape and size.

Fluxes are used—consisting of lime, borax, glass, potash, soda, charcoal, etc.—either singly or mixed together, according to the character of the ore and the precise object to be attained. A knowledge of the constitution of the ore, as determined by the wet method, is valuable as giving a means of judging the best proportions of mixture to be adopted for the flux. When this is not obtainable, the assayer may make several assays, varying the character of the flux until he secures the best results.

The crucible is prepared by filling it with a brasque of four parts powdered charcoal, moistened with one part molasses, well kneaded and hard pressed into place, or driven with a mallet; it is then dried in an oven slowly and thoroughly at so low a heat that the molasses is not charred. A hole is cut down into the mass of charcoal, leaving a lining a quarter of an inch or more in thickness. The ore is carefully powdered, and is then mixed with its flux and placed in the cavity prepared for it, the cover of the crucible, or a cap of charcoal, is then placed upon it, and the joint, luted with fire-clay, is thus hermetically sealed.

This lining supplies carbon for reduction, does not permit adherence of slag or metal to the sides, and strengthens the crucible itself. The slag comes out clean, and can be weighed, and the button contains the whole of the metal.

The crucibles are placed in the midst of the fuel within the furnace, two or three together, and the fire, which should have been allowed to burn low, gradually urged to greater intensity until the fusing point of the charge is attained. It is kept at that point from one to two and a half or three hours, or even more with very refractory ores like ilmenite; it is then allowed to cool; the crucible is removed, slightly jarred to detach any particles that may be clinging to its sides, and set aside to cool. When cold, the cover is removed and the contents examined. If the operation has been successful, a "button" of reduced metal is found at the bottom under the solidified slag. If the heat has been too low, or if the flux has been in-

sufficient in quantity or of improper composition, the charge is found incompletely reduced, and is either a mass of slightly changed character, or is permeated by threads or interspersed metallic beads and grains, and the operation must be repeated. If the experiment is successful, the metallic button is covered with a slag of a gray or green tint and resembling an impure glass. Assays should be made in duplicate or triplicate.

58. To determine the Value of metal assayed: The slag is crushed to a fine powder; the whole is then stirred with a magnet to detect and preserve any minute particles of iron that may have been imbedded in it, and such particles as are found are weighed carefully with the mass of metal found in the bottom of the crucible, and the percentage of metallic iron in the ore is calculated.

By this process, the yield of an ore is determined with considerable accuracy. As the method is very similar to the operation of smelting in the blast furnace, and as the metal obtained is very similar in composition and quality, the assay is usually more satisfactory to the furnace-manager and the iron-maker than the analysis made in the laboratory by the wet method. Both methods should, however, always be adopted where possible.

The quality of the metal obtained by assaying is determined by striking it with a hammer, and noting its strength and malleability. The button should flatten somewhat before breaking, and should present a grayish fracture free from any crystalline appearances. If brittle, weak or crystalline, the metal is defective in character, either in consequence of impurity of the ore, or of defects in the kind and proportions of materials used as flux. The assay should be repeated, in the latter case, with other fluxes, to determine to which cause the fault is due. If due to improper fluxing, experiment will determine the best kinds and proportions of mixture for flux, and it may afford valuable indications of the best proportions of blast-furnace charge.

59. Mushet classifies Ores to be assayed as argillaceous, calcareous, and siliceous, and grades the fluxes in classes suitable for each kind of ore, thus:

TABLE XXVI.

MUSHET'S CLASSIFICATION OF ORES.

I.—*Argillaceous Ores.*

Composition of . . .	}	Ores	{	Clay	(a) 0.50	(b) 0.50
				Lime	0.333	0.35
				Silica	0.167	0.15
					<hr style="width: 50px; margin: 0 auto;"/> 1.00	<hr style="width: 50px; margin: 0 auto;"/> 1.00
Composition of . . .	}	Fluxes	{	Bottle glass	(a) 1.00	(b) 1.00
				Chalk	0.75	1.00
				Charcoal	0.125	0.188
					<hr style="width: 50px; margin: 0 auto;"/> 1.875	<hr style="width: 50px; margin: 0 auto;"/> 2.188

The weights last given are in parts per part by weight of ore.

II.—*Calcareous Ores.*

Composition of . . .	}	Ores	{	Lime	(a) 0.583	(b) 0.500
				Clay	0.250	0.300
				Silica	0.167	0.200
					<hr style="width: 50px; margin: 0 auto;"/> 1.000	<hr style="width: 50px; margin: 0 auto;"/> 1.000
Composition of . . .	}	Fluxes	{	Bottle glass	(a) 1.250	(b) 1.000
				Chalk	0.375	0.500
				Charcoal	0.188	0.125
					<hr style="width: 50px; margin: 0 auto;"/> 1.813	<hr style="width: 50px; margin: 0 auto;"/> 1.625

III.—*Siliceous Ores.*

Composition of . . .	}	Ores	{	Silica	(a) 0.480	(b) 0.455
				Lime	0.320	0.318
				Clay	0.200	0.227
					<hr style="width: 50px; margin: 0 auto;"/> 1.000	<hr style="width: 50px; margin: 0 auto;"/> 1.000
Composition of . . .	}	Fluxes	{	Bottle glass	(a) 0.875	(b) 0.875
				Chalk	0.750	0.625
				Charcoal	0.188	0.125
					<hr style="width: 50px; margin: 0 auto;"/> 1.813	<hr style="width: 50px; margin: 0 auto;"/> 1.625

For very rich ores, containing small quantities of silica, the proportion of flux per ounce is thought to be

Chalk.	0.375	to	0.500
Charcoal.....			0.125

Borax and alkaline carbonates are often added as fluxes, and are very useful with refractory ores.

Blossom uses for the preliminary assay of an ore of unknown character,

	(a)	(b)	(c)	(d)	
Silica,	2.5	1.0	4.0	2.5	grammes
Lime,	2.5	4.0	1.5	2.5	"
Ore,	10.0	10.0	10.0	10.0	"

of which (a) is used for very pure ores, (b) for siliceous ores, (c) for calcareous ores, and (d) for clay ores. For ores containing titanium, a little fluor spar, 0.5 to 10 grammes, is added.

Where ores used have been already analyzed, the effort is made to add fluxes in such proportions as to give finally the proportions recommended by Percy for the slag. The slag, when containing manganese, has the color of the amethyst when a trace is present, shading through yellow and green to brown, as the quantity of manganese is increased. Titanium causes the slag to become very dark, even black, resinous and scoriaceous and wrinkled; in minute quantities it colors the slag blue. The surface is often coated with a copper-colored salt of titanium. Chromium affects the slag somewhat similarly. Improper proportions produce a slag heterogeneous in structure, and may cause failure to secure a reduction of the ore.

When the button contains sulphur, it is "hot-short," powdering under the hammer at a high temperature, but is tougher when cold; phosphorus produces the reverse effect, making the metal "cold-short"; manganese makes the button hard, white, strong and crystalline; titanium has a similar effect, but the button is duller in lustre when fractured.

60. The Relative Value of Ores as a function of the

percentage of pure oxide may be determined with some approximation to accuracy somewhat as the estimate of the value of a fuel containing a given amount of ash is made.

The depreciation due to the presence of gangue is a consequence of the following:

First. The increased cost of mining a given amount of iron oxide.

Second. The increased cost of transportation of the ore per ton of iron oxide.

Third. The increased cost of reduction of the ore per ton of iron oxide.

Fourth. The cost of additional wear of furnace due to the presence of an excess of material passed through it.

Fifth. The cost of removal and final disposal of the additional amount of slag produced by the excess of gangue.

It consequently follows that minerals containing a certain quantity of iron oxide would have absolutely no value as an ore; that below this percentage it would cost so much to work that the furnace manager could not afford to accept it as a gift, and that, above this minimum degree of purity, the value of the ore would increase up to pure oxide. It may be assumed, as a basis, that an ore containing 40 per cent. or less of iron oxide has no market value.

The cost of the removal of the excess of slag cannot be well introduced, as it is a very variable function.

The cost of mining, transportation, and fusing the gangue may be taken as equal to that of the same items as charged against the oxide. The intrinsic value of the oxide is, by reference to the preceding statement, indicated to be sufficient to enable it to carry one and a half times its weight of gangue.

The value of the ore is, therefore, approximately,

$$V = 1 - A - \frac{2}{3}A = 1 - 1.67A,$$

in which the value of pure oxide is unity, and A is the percentage of gangue.

The relative value of the two ores would be

$$\frac{V}{V_1} = \frac{1 - 1.67A}{1 - 1.67A_1}.$$

61. **The Intrinsic Value of an Ore**, as determined by its physical character, is ascertainable only by observing the cost of working the ores classed by their physical characteristics. The cost of the production of each ore is readily estimated by the mining engineer, or by the miner who has had experience in the working of a variety of ores. An illustration of the distribution of items of cost is given in the succeeding paragraph. The actual cost of an ore at the mine, "on the bank," varies from 50 cents, where soft and merely shoveled out of a bank like earth, to \$3 when compact, hard, and difficult of access, and troublesome to work, and to "bring to bank."

To this cost of mining is to be added about 10 cents for each handling, and 2 cents per ton per mile (1.2 cents per tonne per kilometre) for transportation by rail. Hence the total cost,

$$C = M + 0.10H + 0.02D,$$

where M is the cost of mining in dollars per ton, H the number of times the ore is handled, D the distance carried by rail in miles. The cost of wagoning varies too greatly to be included in the estimate.*

The actual cost of a magnetic ore bought at market rates, delivered at the furnace, in a case which may be taken in illustration, was, very closely,

$$V = 1.5I,$$

where the value in dollars per ton was V , and the metallic iron was I .

* It is rarely less than 25 cents, and may become 75 cents per ton per mile.

If O represents proportion of oxide, the cost was about

$$V = 1.1O.$$

62. The Commercial Value of an Ore is largely dependent on the method of mining, which will vary greatly with the location and character of the deposit and the structure of the ore. The market price, the cost of production, and the intrinsic value of an ore, have no natural relation to each other, are seldom found to have any exact proportion, and it often occurs that the commercial quotations of different ores vary greatly from their relative values to the purchaser or the furnace manager.

In general the same methods of mining are adopted for iron ores as for other minerals of similar distribution and physical character.

When the ores are compact and stone-like, and are located at the surface or rising in masses like the "iron mountains" of Rhode Island, Michigan, and Missouri, they are worked by the ordinary process of quarrying. Many of the deposits of brown hematite which are thus situated are soft, and can be shoveled like loose earth.

When the deposits are below ground they are mined like other deposits of similar physical character; and, if soft, the expense of timbering becomes important.

The magnetic and specular ores, and the red hematites, may frequently be worked without timbering.

The following table is given by T. B. Brooks, of Michigan, in the *Report of the Geology of the State of Michigan*, as the average cost, in 1877, of mining the hard, compact, magnetic and specular ores of the Lake Superior mining district.

It will be noted that the cost of mining an ore, in per cent. of the cost of those referred to in the table, which may be taken as a standard, may be expressed, approximately,

$$V = 0.3A + 0.4B + 0.1C + 0.15D + 0.05E,$$

TABLE XXVII.—COST OF EXTRACTION OF IRON ORE.—BROOKS.

	EACH ITEM IN PERCENTAGE OF TOTAL COST PRICE.	COST IN CENTS.	PROPORTIONATE COST OF A TON IN		
			Labor.	Stores.	
I. Preparatory work	Explorations..... 0.6 Sinking shafts..... 1.5 Drifts and levels..... 6.1 Roads..... 0.6 Uncovering rock..... 13.2 Miscellaneous..... 6.1 Holes in stopes..... 4.2 Holes in fragments..... 4.9 Sledging, sorting, etc. } Loading..... } Handing rock..... } Miscellaneous..... } Powder and fuse..... } Nitro-glycerine..... } Steel drills..... } Other tools..... } Blacksmith's supplies..... } Blacksmith's labor..... } Drivers and grooms..... } Fodder..... } Carts, sled, harness, etc. } Manual labor, loading ore..... } Steam power, labor, repairs, materials..... } Salaries and office expenses... } Taxes, all kinds..... }	1.5 4.0 16.0 1.7 35.0 16.0 11.0 13.0 35.0 25.0 21.0 9.5 (?) 1.8 4.3 4.7 11.0 15.0 11.0 0.6 3.5 11.2 12.2	62.0 12.2	12.2	
II. Mining proper (labor)	13.3 39.8 9.5 7.9 3.6 (?) 0.7 11.9 1.6 4.3 4.7 4.2 5.7 4.2 15.6 1.3 4.2 4.6	105.0 25.0 21.0 9.5 (?) 1.8 4.3 4.7 11.0 15.0 11.0 0.6 3.5 11.2 12.2	105.0	21.0 21.0	6.0
III. Mine, store and tools	100.0	100.0	100.0	100.0	
IV. Drawing ore and pumping.		41.3	27.2	14.1	
V. Office expenses, incidentals.		12.2	6.2	6.0	
		\$2.64	\$2.10.7	\$0.53.3	

in which the symbols represent, respectively,

V , the cost of mining,		C , mining tools and stores,
A , preparatory work,		D , raising ore and draining mines,
B , labor in the mine.		E , office expenses.

Multiplying through by 2.5 will give a value, M , which may be substituted in the equation of Art. 61, to obtain the cost of the production of the ore in dollars. It bears no fixed relation to the market value except that it may never be permitted to exceed that value. The expense of taking coal from the seam varies, with the thickness of the latter, from 50 cents to \$1 per ton (10.16 kilogrammes), the thicker seams giving least cost. The expense of working ore of similar physical character, and similarly situated, is about the same.

63. The Dressing of Ores should precede their shipment to the blast-furnace. Ores are never found in a state of absolute purity, and they are frequently mixed with large quantities of rock, earth, etc., which form the "gangue." The separation of the ore from the gangue is the operation known as "dressing the ore."

As the ore coming from the mine is, when compact, rarely either broken to proper size or uniform, it is usually broken up either at the mine or at the furnace. Contracts for ore usually specify the size to which it shall be broken. The separation of gangue is sometimes accomplished by machinery, in which the differences in physical character of the ore and the gangue are utilized in securing their division. The difference is rarely great enough, however, to permit the adoption of this plan, and the masses of foreign material are usually picked out by hand. After breaking the ore and separating the gangue as completely as it can profitably be done, it is "sorted" into heaps varying in character from the cleanest of the ore to the poorest quality which can be sold in the market. The gangue is carted away and dumped where ever it can be disposed of most readily. Earthy matters are sometimes removed by washing.

64. "Weathering Ores" is sometimes a final process in their preparation for use at the furnace. This consists in

their exposure to the air for a considerable time, in order to secure further separation of the foreign matter, the oxidation of the sulphur of pyrites, and the washing away of all impurities which can be removed by rain. This process often occupies months, and sometimes years. Pure and very hard ores are not usually weathered. Ores which are very friable and would be liable to be washed away cannot be exposed to this action.

CHAPTER V.

THE REDUCTION OF IRON ORES—PRODUCTION OF CAST IRON.

65. Preliminary Operations.—The ore supplied to the furnace manager, to whom the duty of superintending all the operations of reduction of the metal is intrusted, is usually subjected to some preliminary treatment before the process of reduction or “smelting” is attempted at the smelting or blast furnace.

These preparatory processes are:

- (a) “Grading” the ore.
- (b) Calcination or roasting.
- (c) Mixing to make up the desired proportions of ore-charge.

66. The Grading of the Ore is not necessary at the furnace when it has already been properly done at the mine. When received at the furnace it is stored in “bins,” each of which receptacles is appropriated to one grade of ore. Several grades are frequently kept in the stock-house, both because it is generally found that mixtures work best in the furnace, and because the varying demands of the market can be met by changing the proportions of the several ores in the charge to produce higher or lower grades of metal.

When the sorting at the mines has not been carefully done, or when a greater number of grades than usual are required, sorting is also practiced at the furnace, and the ore is then distributed to the several bins of the stock-house, which building is erected as near the furnace-stack as possible.

67. Calcination and Roasting are sometimes conducted at the mines, but more usually at the furnace. The terms calcination and roasting are often used interchangeably by

iron makers. Some authorities make an important distinction.

Wagner defines calcination as the exposure of ores to a moderately high temperature with or without access of air, and roasting as the heating of ores to a higher temperature, but under the fusing point, with access of air.

The object of calcination is to expel all volatile constituents, as water, carbonic acid, or bituminous substances, and to soften and open the ores, making them more permeable to the reducing gases, and more easily reducible to the metallic state.

Roasting produces the same result, but more promptly and completely, and the access of air secures oxidation of combustible constituents, and the change of protoxides to peroxides, as occurs in the roasting of spathic iron ores and of magnetites.

The addition of salt is practiced in the roasting of some ores, as of silver, to produce alteration by conversion of the sulphides.

Sulphur, arsenic, zinc, and some other elements, pass off as acid or basic oxides, either free or united with other compounds forming salts.

Iron ores are usually subjected to the second or roasting process. Magnetite ore is roasted to secure openness of structure and to drive off the sulphur and arsenic, and to oxidize the blende, galena, and other impurities which often accompany it; specular iron ores are roasted to drive out pyrites, and other ores to remove water and carbonic acid. Ores containing siliceous matter must be roasted. Especial care is needed when gray iron is to be made.

68. Roasting is performed either in heaps in the open air, or in kilns. During the process the ores lose from 2 to 5 per cent., where nearly pure oxide, to 20 or 30 per cent. in the case of argillaceous ores, and 40 or 50 per cent., in some cases where a blackband, highly charged with carbonaceous matters, is roasted. In the latter case the combustible material in the ore is often nearly sufficient to supply the heat required in the process. This treatment of ores is less frequently

adopted in the United States than in Europe, and has been less usual since the introduction of the hot blast than previously. It is still invariably adopted with ores containing large quantities of volatile substances, and, in Sweden, is usually practiced even with ores, like the magnetites, which contain little or no such matter.

Argillaceous ores, originally containing 30 per cent. metallic iron, contain, after roasting, about 55 per cent.; similarly the percentage of metal rises, in the blackband ores of Scotland, from $33\frac{1}{3}$ to 70 per cent. By thus increasing the richness of the ore a considerable economy of expenditure of fuel in the blast furnace is obtained, and as roasting may often be carried on with fuel unfit for use in the furnace, a marked saving is often effected. In the roasting of blackband ore some deoxidation may occur, but more usually the result is a peroxidation of any protoxide present.

69. Roasting in Heaps is practiced where fuel is cheap and ore inexpensive. It requires a considerable amount of fuel, necessitates keeping large quantities of ore and fuel on hand, and the ore-heaps occupy a large area of ground. The process is uncertain and irregular in its operation, as it is impossible to secure perfect uniformity in the distribution of heat.

The ore to be roasted is first broken into lumps of from 4 to 8 inches (10 to 20 centimetres) diameter. A bed of fuel is prepared, either coal or wood, of a thickness of from 6 to 10 inches (15 to 25 centimetres); over this is spread a layer of ore of from 1 to 2 feet (0.3 to 0.6 metres) in thickness, according to the kind of ore and size of lumps. The coarser and more refractory ores are piled higher. The ore and fuel are thus arranged in alternate strata, and the pile is raised to a height of from 5 or 6 to 30 feet (1.83 to 9.1 metres). Where charcoal is used as fuel the base of the pile is generally of wood, in billets, and the volume of fuel is from 5 to 20 per cent. that of the ore; the former proportion is usual under favorable conditions. Where the ore is fine, chimneys are formed in the heaps, in which the fires are started, and by which the heat is distributed and the combustion regulated. The requi-

sites of satisfactory working are slow combustion, uniform distribution of materials, and a temperature moderately high but always below the fusing point of the ore.

The proportion of fuel to ore is necessarily determined by experiment. The time required varies with the size of the heap, and sometimes extends over several months.

Roasting in mounds instead of in widely spread low heaps, is sometimes practiced. It requires less fuel, but costs more for labor, than the preceding method. A space of about 100 square feet (9.3 square metres), usually oblong in shape, is surrounded by low walls with fire chambers within or below them. Small chimneys are built for draught. In some cases several of these structures are built under a shed roof, divided from each other by party walls. This method is best suited for use with finely crushed materials, and demands much care and some skill on the part of the attendants.

70. Roasting in Kilns, or in shaft furnaces, is practiced very generally, as it is much more economical of fuel, more uniform in results, and far more convenient than the methods already described. It is, therefore, far preferable, as is often the case in the United States, where fuel and labor are not so cheap as to make the saving insufficient to compensate for increased cost of plant.

The kilns should have large capacity in order that the roasting may be done slowly and effectively. They should work continuously and regularly. The ore and fuel are introduced in alternate layers at the top of the furnace, and the roasted ore is removed at the bottom. Several kilns are worked, usually at each smelting furnace. The best kilns are built of boiler plate and lined with fire-brick. The ore and fuel are often brought in cars to the kiln, the rails being laid over their tops, and the stock dropped directly into the top of the kiln.

Preliminary roasting is sometimes omitted, and the blast furnace is given exceptional height in order that roasting may be completed in the furnace itself before the process of reduction commences. The limit to height of furnace, which is fixed by the strength of the fuel and ore, or by the maximum

“burden” practicable, also places a limit upon the extent to which this method can be carried.

The time required for expulsion of volatile matters and for producing the desired change of structural character, varies with every ore. It is usually said that magnetites and sparry ores should be held at high temperature a week, and the less refractory ores from 2 to 4 days, in the kiln. In heaps, more time is needed, as a week to each 20 tons (20,320 kilogrammes), where the quantities vary from 50 to 150 tons (50,800 to 152,400 kilogrammes). The immense piles fired in Europe sometimes burn several months, and the weathering of ores, which is a slow process of roasting by the heat of the sun and of oxidation, sometimes occupies years.

71. Making up the Furnace-Charge is an operation which demands both a knowledge of the chemistry of the blast furnace and of ores, and actual experience in furnace management; the last is absolutely essential to satisfactory production.

The proportions of the charge are determined by the character of the ore, the fuel, and the flux, by the size and method of working of the furnace, and by the character of product required. In general the object to be attained is to secure reduction of the ore most rapidly and completely, with the least expense possible, without risk of injury to the furnace, without the introduction of injurious elements into the pig metal, and to produce a metal of the highest degree of carbonization consistent with other prescribed conditions.

72. The Character of the Ore is not always a matter of choice. When possible, magnetic ores are selected where the cast iron produced is to be made into fine cast steel. Specular or magnetic ores are suitable for “low” steels and fine wrought iron, and the other ores make foundry iron of various qualities.

Charcoal, as fuel, contaminates the product least. Coke and anthracite coal, if carefully selected, make good iron; the bituminous coals are least valuable, and are generally used only for making cheaper grades, as they contain objectionable proportions of sulphur.

The temperature of blast influences the choice of other materials. As the hot-blast causes the reduction of silica and the introduction of impurities to a much greater extent than the cold-blast, it is more essential that with the former greater care should be taken in selecting stock. Wood and peat have sometimes been tried in the blast furnace, but not with such results as to have secured their continued use as fuel.

Limestone, which is the usual flux, should be carefully examined where a choice is permitted. The presence of phosphorus is quite usual, and its effect, except for making very fluid foundry iron, is very objectionable. Magnesian limestone is refractory, and cannot be well managed, especially at the low temperature of the cold-blast furnace.

Fluor spar, which is sometimes used with limestone, should be examined for phosphorus, which may be present as apatite.

Silica, alumina, and magnesia, in fixed relative proportions, are required in the blast furnace, and are usually found in the ore.

The fluxes are best when containing some iron. When the ore is siliceous, lime and clay are added as flux; calcareous ores require silex and alumina; and clay ores are fluxed with sand and limestone. The slag produced by the fusion of the flux with the earthy matters in the ore, should, according to Percy, consist of silica 38, lime 47, alumina 15, and, according to Overman, silica 40, lime 20, alumina 12, and magnesia 12; the presence of manganese and oxide of iron is of advantage. Bodeman gives, as the composition of the most readily fusible silicate of alumina and lime, silica 56, lime 30, alumina 14. Very wide variations of proportion are thus sometimes observed without serious loss of quality of product. The proportion of lime is rarely brought up to that indicated by Percy, except with very rich ores.

73. Charges.—Ore containing 60 per cent. of iron has been used in the following proportions per ton, or kilogramme, of foundry iron made (temperature of blast, 900° Fahr., 482° Cent.):

Magnetic ore.....	1.67 tons, or kilogrammes.
Limestone.....	0.65 ton, or kilogramme.
Coal (anthracite).....	1.33 tons, or kilogrammes.
Total charge per ton (1,016 kilo- grammes) iron.....	<u>3.65 tons, or kilogrammes.</u>

A similar ore, containing 50 per cent. of metal, was used as follows:

Magnetic ore.....	2.00 tons, or kilogrammes.
Limestone.....	1.2 tons, or kilogrammes.
Coal.....	1.6 tons, or kilogrammes.
Total.....	<u>4.8 tons, or kilogrammes.</u>

For ore containing 40 per cent. of iron :

Magnetic ore.....	2.50 tons, or kilogrammes.
Limestone.....	1.75 tons, or kilogrammes.
Coal.....	2.00 tons, or kilogrammes.
Total.....	<u>6.25 tons, or kilogrammes.</u>

A Swedish charge is made up of

Siliceous magnetite.....	1.5 tons, or kilogrammes.
Very pure magnetite.....	0.3 ton, or kilogramme.
Manganiferous magnetite.....	0.2 ton, or kilogramme.
Specular hematite.....	0.2 ton, or kilogramme.
Scrap iron.....	0.1 ton, or kilogramme.
Limestone.....	0.4 ton, or kilogramme.
Total.....	<u>2.7 tons, or kilogrammes.</u>

One hundred and eighty bushels (6,343 litres) of charcoal is used per ton (1,016 kilogrammes) of ore. The iron made is about one-half the weight of ore charged. It contains considerable sulphur, but is found, nevertheless, to be excellent ordnance iron.

Specular and red hematite charges are made up in a similar manner, as, for example, per ton or kilogramme :

Ore.....	1.5 tons, or kilogrammes.
Limestone.....	0.4 ton, or kilogramme.
Coal (semi-bituminous).....	1.8 tons, or kilogrammes.
Total.....	<u>3.7 tons, or kilogrammes.</u>

The yield is one ton or kilogramme of No. 1 foundry iron. The ores contained 66 per cent. iron. In another example, with temperature of blast, 750° Fahr. (379° Cent.):

Red hematite.....	0.6 ton, or kilogramme.
Specular ore.....	0.6 ton, or kilogramme.
Brown hematite.....	0.6 ton, or kilogramme.
Limestone.....	0.5 ton, or kilogramme.
Coal.....	2.0 tons, or kilogrammes,
Total.....	<u>4.3 tons, or kilogrammes.</u>

Red hematite from the north-west of England (Cumberland), is charged in the proportion of

Red ore.....	400
Argillaceous ore.....	25
Charcoal.....	400

and makes a gray pig-iron, which is well adapted for use in the pneumatic process of making steel, and for malleableized cast iron.

The records of a month's work at a furnace, using magnetic ores, in the United States, gave :

Ore charged.....	2,500,000 lbs.....	1,112,400 kilos.
Coke charged.....	1,500,000 lbs.....	680,400 kilos.
Coal charged.....	1,500,000 lbs.....	680,400 kilos.
Limestone charged.....	600,000 lbs.....	272,160 kilos.

and product of iron 650 tons (660,400 kilogrammes) of No. 1 forge pig.

The yield of the ore was therefore above 60 per cent.

With brown hematite, roasted, similar proportions of charge are used. Argillaceous ores in the proportions of charge per ton, or kilogramme.

Ores.....	2.5 tons, or kilos.
Limestone.....	0.8 ton, or kilo.
Coke.....	1.5 tons, or kilos.
Coal.....	0.2 ton, or kilo.
Total.....	<u>5.0 tons, or kilos.</u>

yielded, with the blast at 600° Fahr. (316° Cent.), a fair

quality of gray iron. In another case, the charge had the proportions :

Ore.....	3.00 tons,	or	3,048 kilos.
Limestone.....	0.75 ton,	or	762 kilos.
Coke.....	2.25 tons,	or	2,286 kilos.
Total.....	6.00 tons,	or	5,996 kilos.

and made a foundry iron of good quality.

A mixture of ores in the proportions :

Argillaceous ores.....	2.0 tons,	or	2,032 kilos.
Red hematite ores.....	2.0 tons,	or	2,032 kilos.
Brown hematites ore....	0.6 ton,	or	610 kilos.
Total.....	4.6 tons,	or	4,674 kilos.

yielded No. 2 gray iron, of excellent quality.

Kent gives the following as the distribution of solid materials in proposed charge for each 100 parts of iron produced :*

TABLE XXVIII.

COMPOSITION OF FURNACE CHARGE.

CHARGE.		IRON.	SLAG.	GAS.
Ore, 160 lbs. (72.64 kilos.)	Iron	94.75	94.75
	Oxygen.....	39.62	39.62
	Phosphorus.....	0.43	0.43
	Titanic acid.....	0.64	0.64
	Lime.....	1.83	1.83
	Magnesia.....	0.37	0.37
	Alumina.....	3.73	3.73
	Silica.....	13.83	13.83
	Sulphur.....	1.12	1.12
	Moisture.....	3.57	3.57
Coal, 130 lbs. (59.02 kilos.)	Oxide of manganese.....	0.11	0.11
	Carbon.....	118.95	4.15	114.80
	Silica.....	3.95	3.95
	Alumina.....	3.02	3.02
	Ferric oxide.....	1.01	0.91 fer's. ox.	0.10 oxygen.
	Lime.....	1.12	1.12
	Vol. matter and sulphur..	1.95	1.95
	Lime.....	9.12	9.12
	Magnesia.....	5.79	5.79
	Carboic acid.....	12.78	3.49 carbon.
Limestone, 29.64 lbs. (13.45 kilos.)	Alumina.....	0.24	0.24	9.25 oxygen.
	Silica.....	1.44	0.77	0.77 oxygen.
	Water.....	0.27	0.27	0.27
			0.67 silicon.	
Total.....		319.64	100.00	44.66
				174.98

* *Engineering and Mining Journal*, Vol. xxii.

74. **The Constituents of the Charge** are weighed out separately, and, for small furnaces especially, are very carefully mixed before charging into the furnace. In mixing, each kind of ore and the flux, after it has been broken properly, is weighed, and spread over the floor in strata of uniform thickness, one over another, and the charges are taken in barrows to the furnace from this heap.

Large furnaces are charged with a stated number of barrows of each material regularly in rotation.

Changes of proportions are sometimes necessary. A reduction of the proportion of fuel produces a greater tendency to yield white iron, and gray iron is obtained by using some excess of fuel. When furnaces work cold, and when "bears" commence forming, the proportion of fuel must be increased. Such changes should always be made as gradually as possible in order that their effect may be observed in time to avoid injury to the furnace, waste of fuel, or loss of quality of product.

75. **The Form and Dimensions of the Blast Furnace** in which the ore is commonly reduced vary greatly. Charcoal furnaces, shown in the figure, are usually of small size; furnaces using coke or anthracite coal are often very large. The former are seldom 10 feet (3 metres) in diameter, or 40 feet (12.19 metres) high; the latter are often 75 feet (22.5 metres) high and above 25 feet (7.5 metres) in diameter of bosh, and have been built for coke in Yorkshire, Great Britain, 28 feet (8.4 metres) diam-

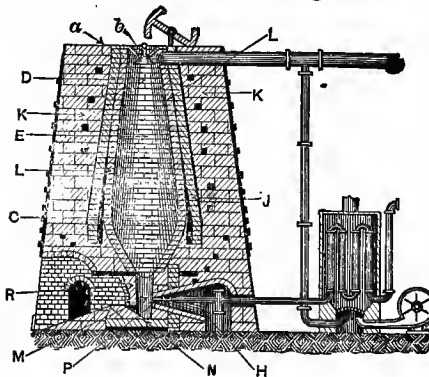

FIG. 4.—CHARCOAL FURNACE.

eter, and a maximum height of over 100 feet (30.5 metres) has been attained.

A charcoal furnace 9 feet (2.7 metres) in diameter and 32 feet (9.6 metres) high, making 1,500 tons (1,524,000 kilo-

furnaces using coke or anthracite coal are often very large. The former are seldom 10 feet (3 metres) in diameter, or 40 feet (12.19 metres) high; the latter are often 75 feet (22.5 metres) high and above 25 feet (7.5 metres) in diameter of bosh, and have been built for coke in Yorkshire, Great Britain, 28 feet (8.4 metres) diam-

grammes) of cold-blast iron per year, represents a usual practice in the United States, and a coke or anthracite furnace 20 feet (6 metres) in diameter of bosh and 75 feet (21 metres) high, with a capacity for making 20,000 tons (20,320,000 kilogrammes) of hot-blast iron per annum, is representative of ordinary practice; more than four times this product has been made. Furnaces of considerably larger size have been built.

The figure represents the warm-blast charcoal furnace. The charge is thrown from the charging-floor, *a*, into the hopper, *b*, and rests upon the cone, *D*. A lighted taper is thrown upon it to inflame the furnace gases which rise when the charge enters, and the cone is then quickly depressed and as quickly elevated again, the ore falling into the furnace during the instant that the top is thus opened.

As the fuel is burned, and the reduced ore and cinder tapped off at the bottom, the furnace is kept filled from the top.

Each charge, entering at the throat of the furnace, *D*, gradually slides down the stack, *EE*, to the bosh, *CC*, and, finally, the carbon having been withdrawn by oxidation and by combination with the iron, the latter and the slag fall into the hearth, *A*, and are tapped off at the front of the furnace.

The air which supports combustion is forced into the furnace under a pressure of from 1 pound in some coke furnaces and $2\frac{1}{2}$ pounds per square inch (0.16 atmosphere) in small charcoal furnaces, to 9 pounds (0.6 atmosphere) or more in large anthracite furnaces, and at a temperature which varies from that of the atmosphere to 1,000° Fahr. (593° Cent.), and sometimes to 1,200° (649° Cent.), or even 1,400 Fahr. (760° Cent.). It enters through the tuyeres, *P*, which latter are set in the tuyere arches, *II*.

The tuyeres and the arches are kept cool by the circulation of water through them, either in coiled pipes or in their hollow walls.

The walls of the furnace are double and are separated by a space, *JJ*, which is filled with water-worn sand, ordinary soil, broken bricks, or refuse material of any kind that will not coke at the high temperature likely to exist there. The

outer walls, *KK*, are usually built of red brick, and where unprotected by an external jacket, they should be sufficiently "hard burned" to resist the action of the weather. Less strength and greater range of elasticity may be found suitable where a sheet-iron jacket covers the whole structure. The inner walls, *LL*, are constructed of fire-brick, which may be obtained of any required shape and of any convenient size from the makers. It should not be liable to great change of dimensions with change of temperature. The whole furnace is usually banded with iron hoops, or is encased in a jacket of boiler plate, which gives it strength and protects it from the injurious action of the rain.

The hearth, *mm*, is built of fire-brick arranged as in the "plate-band" of the architect, or of some refractory stone set in as large masses as possible. It is very carefully laid, and every precaution is taken to prevent injury by the escape of fluid iron through it. The hearth is sometimes floated up by the formation of a pool of molten iron below it or between its layers. It has sometimes happened, also, that the molten iron has found its way down through the foundation, and large quantities have been lost.

The reduced metal and slag fall into the crucible, *A*, and the cinder flows off through the opening between the trough, *N*, and the dam-plate, *R*, while the former is tapped out at the tap-hole, which is situated at the bottom of the crucible. The tap-hole is plugged with sand, which material is easily driven into the opening, forms a perfect seal and is readily removed by an iron bar. The front of the furnace at the dam-plate is frequently closed by a "cinder-block," through which a hole is made of proper size, and the slag or cinder issues from this continuously. Where this plan has been properly carried out, it is said to result in greater regularity of action, an increased and more uniform yield, greater economy of fuel, and a reduced waste of blast. Fig. 13, page 129, represents the modern iron-jacketed furnace, with fire-brick stoves, and all the usual arrangements of a large anthracite furnace.

The Rachette blast furnace is an European form of furnace of limited actual application. It is of rectangular hori-

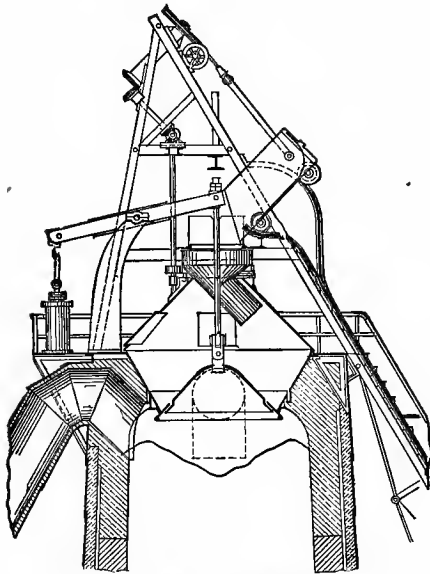

COPYRIGHTED BY GASSIEN'S MAGAZINE, NEW YORK
BLAST-FURNACE TOP.

zontal section, narrow and long, and widens all the way from the tuyeres to the top.

A blast furnace should be built with care and skill of the best material, and the masonry should be laid up slowly and given ample time to set. The foundation is sometimes made of concrete or beton, and, in such cases, should be given ample

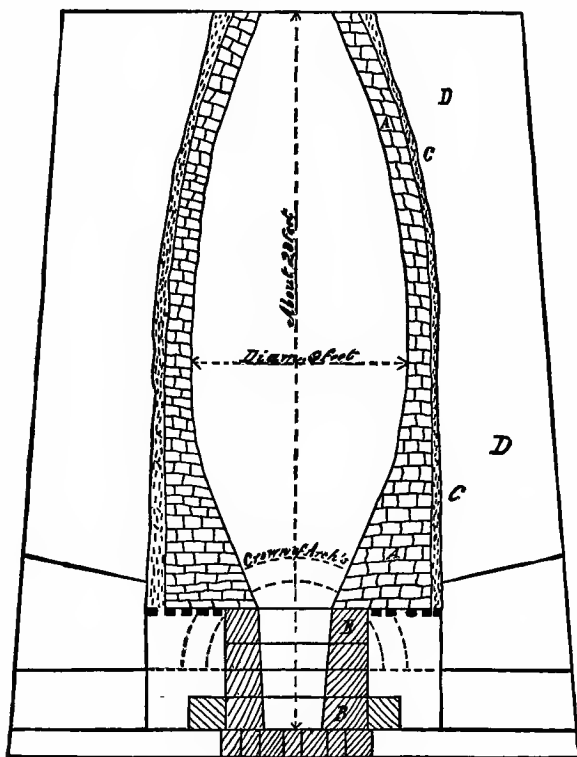

FIG. 5.—FURNACE SECTION.

depth—six to eight feet for large furnaces—and the walls of the furnace should only be started after the foundation is sufficiently firm to bear the superincumbent weight without cracking or settling. Fig. 5 is a section of a charcoal furnace of fair size, which has done good work.

Fig. 6 represents a section of one of the latest forms of

charcoal furnace now used at Salisbury, Conn. The air for this is conducted from the blower to the pipe, *A*, which is located in an oven, *OO*, into which the hot gases from the furnace are admitted through an archway, *F*.

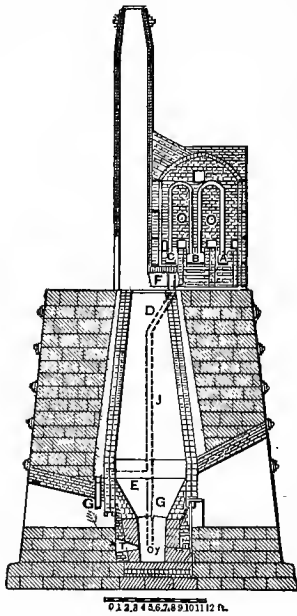

FIG. 6.—CHARCOAL FURNACE.

The blast for the furnaces is warmed up to about 400° Fahr. (205° Cent.), and has a pressure of from one-half to three-quarters of a pound per square inch (.03 to .05 atmosphere).

76. The Shape of the Blast Furnace is, to a limited extent, optional; narrow tops cause greatest separation of the fine from the coarse material of the charge descending in the furnace, and do not exhibit the effect of scaffolding promptly. Wide tops carry more stock, are sensitive, as indicators of scaffolding, and do not cause the separation of coarse from fine parts of charge; they usually do better and cheaper work than the preceding, provided they are driven harder than narrow furnaces. Blast pressures of nine and ten pounds (0.6 to 0.7 atmosphere) are not considered too high for anthracite or coke furnaces. A height of 75 to 80 feet (22.5 to 24.0 metres) for anthracite and coke furnaces gives a good

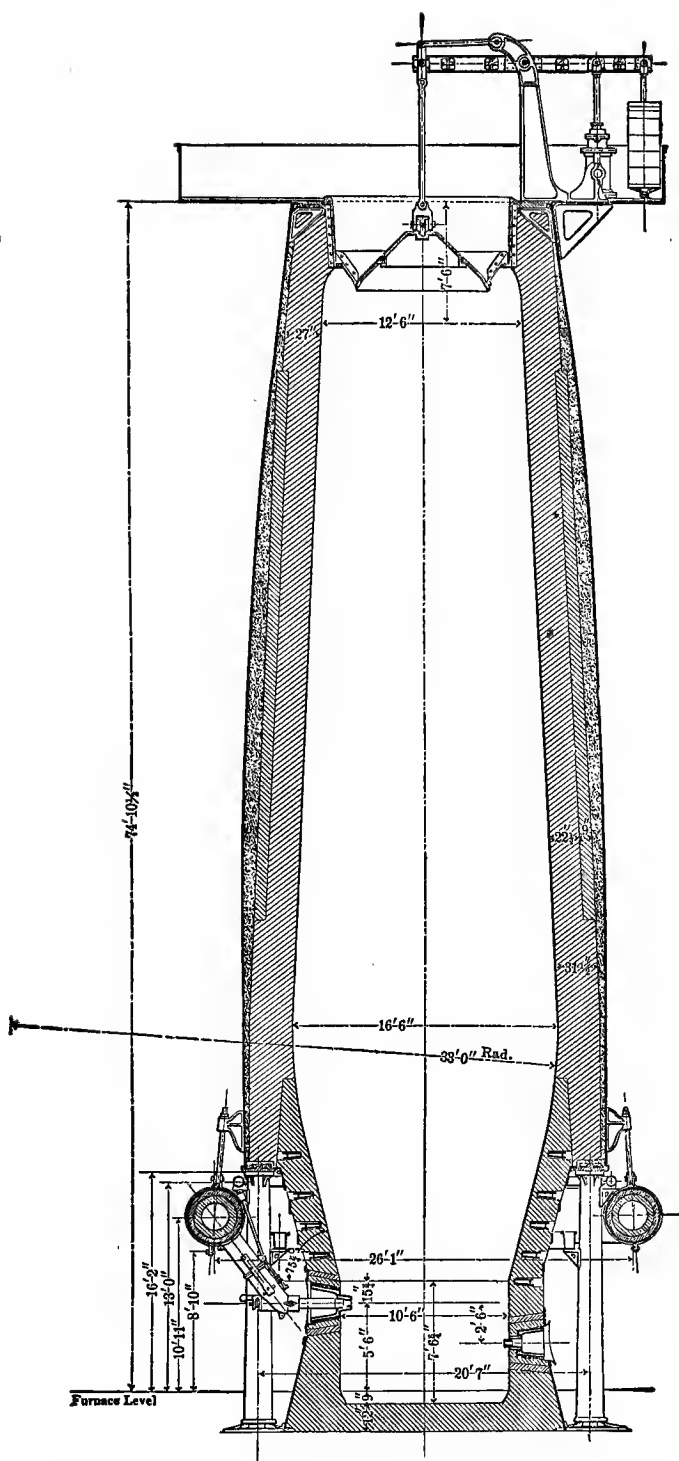

FIG. 6a.—ELEVATION DOVER (U. S.) COKE-FURNACE.



FIG. 6*b*.—MODERN BLAST FURNACES.

working condition. Scaffolding occurs whenever any part of the furnace-wall within the zone of fusion becomes cooled below the temperature of fusion.

The stock then adheres to the furnace wall and prevents the material above from descending regularly, by forming an abutment to an arch, which is naturally formed above it, and thus sustaining the whole mass, until, the supports giving way suddenly, it lets down the stock; and then the process repeats itself. This is usually checked by increasing the temperature of the blast; but it may be less effectively overcome by other means.

As coke is more bulky than anthracite, a furnace running on coke will carry but about half the stock of an anthracite furnace. Coke introduced into an anthracite furnace increases the temperature and elevates the zone of fusion. Anthracite added to coke raises the pressure by its closer packing and its pasty character at high temperatures. Tuyeres are best placed high, say 5 feet (1.5 metres) or more above the hearth, and the cinder-notch 2 feet (0.6 metres) lower, to keep the cinder well under the streams of entering air. The pool of iron lying molten in the hearth is full of coal; and there the carbonization is completed out of contact with air, from which it is separated by the superincumbent blanket of cinder. Coke is porous, spongy, and burns at about 900° Fahr., or about 500° Cent. Anthracite is hard, compact, dense, and takes fire at perhaps 1,300° Fahr., or about 700° Cent.

An excessively high temperature causes an excessively large reduction of silicon. This is an advantage for Bessemer steels, in slow working, but not for iron for other uses.

Anthracite should be broken somewhat finely (cubes of 3 to 4 inches, 7.62 to 8.16 centimetres), in order to secure surface for ignition and combustion, as it cannot burn through-out like the more spongy coke.

Ordinary anthracite furnaces run stock through in 2½ to 3 days; charcoal, in often less than half a day; and coke in a single day or less, the temperature of the blast being 800° to 900° Fahr., or about 450° to 500° Cent.

In furnaces working properly, the air supply should be

just sufficient to supply the oxygen necessary to burn the carbonic oxide.

77. Cost.—An accurate method of calculating cost in estimates where the composition of ore, fuel, and flux is known, would include separate estimates of all elements as obtained by analysis, and would give a result thus, using figures supplied the Author by Messrs. Taws & Hartmann* for a case in which coal costs \$2.86 at furnace, limestone, 50 cents per ton (1,016 kilogrammes) and ore \$3.00, when containing 46 per cent. iron, 16 per cent. silica, and 28 per cent. lime and other basic materials.

Four pounds or kilogrammes of limestone are estimated for per pound or kilogramme of silica present, and the cinder is reckoned as having five times the weight of the silica. The coal is taken as at a furnace running with blast at about 1,200° Fahr. (649° Cent.), and running gas at about 275° Fahr. (135° Cent.), where 1,400 pounds (636 kilogrammes) were consumed per ton (1,016 kilogrammes), and the cinder calls for 0.309 of its own weight of coal.

The statement then reads thus :

WEIGHT OF COAL.

For one ton (1,016 kilogrammes) iron.....	1,400 lbs.	636 kilos.
For cinder 3,900 lbs. × 0.309.....	1,205 "	547 "
Total.....	2,605 "	1,183 "

WEIGHT OF ORE.

46 per cent. ore per ton, 2.176 tons..	4,875 lbs.	2,213.00 kilos.
16 " silica, 0.16 × 4.875.....	780 "	353.12 "
28 " lime, etc., 0.28 × 4,875....	1,365 "	619.71 "
46 " iron ore, 0.46 × 4,875.....	2,240 "	1,015.96 "
Total.....	9,260 "	4,201.79 "

LIMESTONE.

780 × 4 (4 × silicon).....	3,120 lbs.	1,416.48 kilos.
Deduct bases in ore.....	1,365 "	619.71 "
Total.....	2,485 "	2,035.19 "

* Bulletin Iron and Steel Assoc., Vol. XIII., p. 69.

Finally we make up cost, thus :

Coal	$\frac{2,600}{2,240} = 1.17$	ton @ \$2.86	\$3.35
Ore	$\frac{4,875}{2,240} = 2.176$	" " 3.00	6.52
Stone	$\frac{1,755}{2,240} = 0.800$	" " .50	40
Int., repairs, etc			2.40
Labor			1.58
Total			14.35

The same authority estimates average cost of labor per ton of iron made thus, as low figures :—

70 per cent. ore	\$1.10
60 " "	1.30
50 " "	1.50
40 " "	1.70

Costs, are, however, continually changing with price of labor. They are now (1898) not far from two thirds the above figure.

Estimates are best made on No. 3 iron.

78. Putting the Furnace in Blast is an operation which requires great care and considerable time ; since rapid elevation of temperatures, caused by irregular expansion, would be certain to crack the lining of the furnace, and might produce serious damage.

The dam-stone is left out of place until the furnace is heated up. A small fire is first made in the crucible, and a gentle heat gradually dries the masonry of the interior, and warms up the furnace walls. This fire is kept up some days, and is then very gradually increased by adding fuel and small quantities of ore and flux, until, after several weeks, the furnace is filled to the mouth. As the supply of fuel is increased, and the furnace becomes hot enough to reduce the ore, and to melt the cinder, ore and flux are added in larger proportions, and the blast is finally turned on, and the operation of smelting is then fairly commenced. The furnace is very gradually supplied with a larger and larger proportion of ore and flux, and its "burden" is thus increased, until,

after some weeks, it is producing a maximum amount of iron. In some cases, the furnace is filled at once to the top, and, with a low charge of ore, started at once making iron.

When the furnace goes out of blast, as it must after a run which may be a few months or may be eight or ten years, the same care is taken in cooling it down. In this case, the proportion of ore in the charge is gradually reduced and that of limestone increased, until, finally, the fire burns out, and the furnace stands full of burned lime. It is then left to cool, and is not opened until it has become quite cold.

79. The Chemistry of the Process of ore reduction in the blast furnace has been carefully studied, and is becoming well understood. The reactions are too complicated and numerous for description here. They are given in works on metallurgy. The principal chemical changes may, however, be briefly stated.

The charges, entering at the bell, slowly descend toward the hearth; the air, forced into the furnace through the tuyeres, rises through the mass of material filling the shaft, and, meeting with fuel at a temperature much higher than that required to produce combustion, the oxygen unites with the carbon of the fuel to form carbonic oxide and carbonic acid. The carbon dioxide at once meets with other fuel, and surrenders to it one atom of oxygen, and two molecules of carbon monoxide are produced, and this gas rises through the superincumbent material, accompanied by all the nitrogen of the air.

Below the zone of incandescent carbon, the metal present is deoxidized, and to some extent carbonized. Above this zone the rising carbon monoxide meets the unchanged ore, and at a temperature which, while permitting deoxidation, does not fuse the iron. Here a portion of the gas takes up another atom of oxygen, thus becoming carbonic acid, and in that state passes out of the top of the furnace.

The issuing gas is not entirely free from carbonic oxide. Much of the carbon monoxide escapes complete oxidation, and the furnace exhibits a gradual decrease in the proportions of carbonic oxide, and increase of carbonic acid,

from the bottom to the top. In the issuing gas, in cases cited by Percy and other authorities, the proportion of carbonic oxide falls from about 35 or 40 per cent. at the tuyeres to 25 per cent. at the top, while the proportion of carbonic acid is still more variable, but usually reaches about 12 or 15 per cent. at the furnace mouth.

The proportions in a typical case were :

	Volumes.
Nitrogen.....	55
Carbonic oxide.....	25
Carbonic acid.....	10
Hydrogen.....	6
Marsh gas.....	3
Olefiant gas.....	1
	100

The total distribution of all materials in the furnace, including gases, is given by Kent for the case already quoted, in the article above on ore-mixtures, in Table XXIX.

80. Investigations made by Akerman, Bell, Gruner, Schinz and Tunner, have yielded some valuable results.

Schinz, of Strasburg, first showed it to be essential that the analyses of the waste gases should be made a basis of all conclusions as to the character and succession of phenomena of reduction. He showed experimentally that the influence of temperature, quantity of gases, proportion of carbonic oxide present, time given, and the quality of material, were all to be carefully observed, and that each had an important influence in determining reactions. He indicated that, when the precise character of the charge is known, it is possible to calculate, by analyzing the waste gases, the quantity of carbon not burned at the tuyeres.

Bell made a series of analyses of escaping gases, and concluded that, in the cases examined—the reduction of calcined argillaceous ores, with coke as fuel—the reduction of the ore was completed at a very low temperature, and the size and form of the pieces of ore modified the position in the furnace, and the temperature, at which the change occurs. He concludes that, with sufficient time to permit complete permeation of the ore by the reducing gases, a temperature of 637°

TABLE XXIX.—DISTRIBUTION OF ALL THE MATERIALS OF THE CHARGE.

CHARGE.	LBS.	IRON.	CARBON.	OXYGEN.	NITROGEN.	WATER AND VOLATILE MATTER.	SULPHUR.	PHOSPHORUS.	SILICA.	LIME.	MAGNESIA.	ALUMINA.	TITANIC ACID.	MANGANOUS OXIDE.
Ore.....	160.9	94.75	39.62	3.57	1.12	.43	13.83	1.83	.37	.37	.64	.11
Coal.....	130.	fer's ox.	118.95	.10	1.95	3.95	1.12	3.02
Limestone.....	29.64	3.49	{ .77 } { 9.29 }2767 silicon.	9.12	5.79	.24
Air.....	584.56	134.51	450.05
Moisture in air.....	3.62	3.62
Total.....	907.82	95.66	122.44	184.29	450.05	9.41	1.12	.43	18.45	12.07	6.16	6.99	.64	.11
Subtract iron.....	100.00	94.75	4.1543	.67 silicon.
Subtract slag.....	44.66	fer's ox.	17.78	12.07	6.16	6.99	.64	.11
Leaves gas.....	763.16	118.29	184.29	450.05	9.41	1.12
Composition of gas, per cent.....	15.50	24.15	58.97	1.24	.14
Composition of slag, per cent.....	2.04 fer's ox.	39.81	27.03	13.79	15.65	1.43	.25

Percentage of carbonic acid $[CO^2 = \frac{1}{2}(3O - 4C)] = 9.38$
 " " " oxide $[CO = \frac{1}{2}(3C - 3O)] = 30.07$ } $C + O = 39.65$ per cent. Ratio $\frac{CO}{CO^2} = 0.3186$.

to 842° Fahr. (336° to 450° Cent.) is sufficient for insuring complete reduction. Other authorities place the figures much higher. Tunner stating the process to commence at 1,256° Fahr. (680° Cent.), and to end at 2,552° Fahr. (1,400° Cent.), the latter temperature being that of incipient fusion of cast iron. Bell found the process of reduction to commence as low as 284° Fahr. (140° Cent.), and from that temperature up to 410° Fahr. (210° Cent.). The temperature of oxidation of metallic iron by carbonic acid is, according to Bell, about 779° Fahr. (415° Cent.). The same authority supposes the expulsion of the oxygen from the ore to take place near the top of the furnace. At the same time the carbon of a part of the carbonic oxide is withdrawn and deposited by the splitting of the gas into its elements, and a simultaneous formation of carbonic oxide. Thus, $2CO = CO^2 + C$. At higher temperatures near the tuyeres, this peculiar action ceases. Schinz had noted the deposition of carbon before Bell's explanation was given.

The impregnation of the iron by carbon, to form "cast iron," is supposed to commence at the lower limit of temperature, and to be checked at a red heat. It is unknown whether a further absorption of carbon occurs on contact of the metal with the incandescent carbon in the crucible.

The carbonic acid of the limestone used as flux, is believed to leave the furnace reduced principally to carbonic oxide, which belief is not, however, shared by all metallurgists.

The efficiency of the fuel, or the calorific efficiency of the furnace, is considered by Mr. Bell to be indicated by the value of the ratio of the two carbon compounds leaving the furnace, *i. e.*, $\frac{CO^2}{CO}$, and Gruner confirms this view. The author is inclined to suppose that the working of hot-blast furnaces should be gauged by the composition of the gases at the chimney rather than at the top of the furnace. Kent has shown* that an index of ultimate efficiency is the ratio of the weight of gases escaping from all the chimneys to the weight of oxygen contained in them if combustion has become com-

* *Engineering and Mining Journal*, 1876.

plete. A great loss of efficiency usually occurs by waste of heating power of the gases. A certain amount of carbon monoxide is necessary to heat the blast and make steam, and a perfect oxidation of carbon in the furnace would render the working of the furnace inefficient by compelling the use of a cold blast. The quantity $\frac{CO^2}{CO}$ is taken, however, as the index of the working of the furnace *per se*. The absolute value which makes the efficiency a maximum will probably vary with every variation in character of charge, temperature of blast, and size and form of furnace. A common value in Yorkshire (England) practice, is 0.60; the maximum theoretical value would be 1.2; more usual values are from 0.45 to 0.50, and a practical maximum 0.8.

Bell supposes the development and expenditure of heat in the furnace treated of by him, to be as follows:

TABLE XXX.
DISPOSITION OF HEAT.

	BRITISH HEAT UNITS PER CWT.
Heat produced from the combustion of fuel, about	81,536
“ received with the blast	11,919
Total	93,455
Heat expended in Evaporation of moisture in fuel.....	312
“ Reducing iron.....	33,108
“ Introducing carbon.....	1,440
“ Expelling carbonic acid from flux.....	5,054
“ Decomposing carbonic acid.....	5,248
“ Reducing moisture.....	2,720
“ Reducing other elements.....	4,174
“ Fusing the reduced metal.....	6,600
“ Fusing the cinder.....	16,720
“ Loss by conduction, radiation, etc.....	18,079
Total.....	93,455

To convert to metric measures, one heat unit per pound equals 0.556 calorie per kilogramme.

The heat required for complete reduction is seen to be about one third the total amount demanded for all purposes. The advantage in heating the blast is seen, also, to consist in

the avoidance of the necessity of heating so great a quantity of material within the furnace, and in thus securing higher temperatures and more rapid fusion of the charge.

81. The Changes in the Furnace, other than those above described, are, principally, incidental reductions of compounds of silicon, sulphur, phosphorus, and other elements, the formation and fusion of slag, and the fusion of the pig iron produced.

The silicon is principally taken away as silica in the slag, with the lime, magnesia, and a small proportion of sulphur and phosphorus possibly. The remainder passes into the iron with some carbon, the greater part of the sulphur, and nearly all of the phosphorus, and with small proportions or traces of every metallic element present in the furnace charge.

The issuing cinder is a silicate of lime and magnesia, with small proportions of other elements; and the metal tapped from the furnace contains from 3 to 6 per cent. carbon, from 1 to 3 per cent. silicon, and minute quantities of other elements. Its precise constitution will be treated of at some length hereafter.

82. The Specific Gravities, and Specific Heats at the boiling point of water, for materials charged into the blast furnace, are as follows:

TABLE XXXI.
SPECIFIC HEATS AND SPECIFIC GRAVITIES.

MATERIAL.	SPECIFIC GRAVITY.	SPECIFIC HEAT.	WEIGHT.	
			PER CUBIC METRE IN KILOGRAMMES.	PER CUBIC FOOT IN POUNDS.
Anthracite coal.	1.27 to 1.92	0.2017	1,270 to 1,920	79 to 120
Bituminous coal.	1.23 to 1.36	0.2009	1,230 to 1,360	77 to 85
Coke.	0.76 to 0.82	0.1571	760 to 820	47 to 50
Soft charcoals.	0.38 to 0.40	0.2415	380 to 400	24 to 25
Hard charcoals.	0.45 to 0.48	0.2415	450 to 480	28 to 30
Magnetic ore.	5.3 to 6.0	0.1667	5,300 to 6,000	331 to 374
Red hematite.	4.7 to 5.3	0.172	4,700 to 5,300	293 to 331
Brown hematite.	3.9 to 4.0	0.154	3,900 to 4,730	243 to 250
Spathic ores, raw.	3.6 to 3.9	0.116	3,600 to 3,900	225 to 243
Spathic ores, roasted.	4.61 to 4.73	0.16	4,610 to 4,730	288 to 295
Limestone.	2.25 to 2.84	0.1666	2,250 to 2,840	140 to 177
Lime.	2.00 to 3.08	0.217	2,000 to 3,080	125 to 192

Knowing these quantities, it is easy to estimate temperatures and quantities of heat wherever definite conditions of operation can be stated.

The specific heats increase slowly with rise of temperature, approximately doubling with an increase of $1,652^{\circ}$ Fahr. (800° Cent.) for coke, becoming increased four times in the same range with limestone, and increasing 50 per cent. with lime and with hard ores, and 10 per cent. with charcoal.

At $3,632^{\circ}$ Fahr. ($2,000^{\circ}$ Cent.) charcoal has a specific heat of 0.30, coke 0.50, pig metal 0.167, and slag 0.4.

83. The Size of the Blast Furnace has an important influence in determining the cost of production and the yield, as shown in Fig. 8. The ordinary sizes of furnaces using different fuels and hot and cold blast have already been given. The direction of change has been, for many years, in that of enlarged stacks.

The largest furnaces in the world are those in the Cleveland district, in the North Riding of Yorkshire, England, the largest having been 30 feet (9 metres) in diameter and the highest exceeding 100 feet (30 metres) in altitude. It is found that neither the economy nor the yield of the furnace increases to any important extent with the increase in capacity over these extreme dimensions. The largest furnace of 30 feet (10 metres) bosh, has been reduced in diameter to 27 feet (9 metres) by lining it. With the same class of furnace, 200 cubic feet (5.7 cubic metres) of capacity is demanded per ton (1,016 kilogrammes) of iron made per day in furnaces of 5,000 cubic feet (141.6 cubic metres) contents, while 300 cubic feet (8.5 cubic metres) are required per ton (1,016 kilogrammes) with furnaces of double this size, and 500 (14.16 cubic metres) in furnaces of the largest size named.

In the United States coke-furnaces are worked 100 to 105 feet high, 23 to 25 feet in diameter, with blast supplied by stoves 120 feet in height, reversed each two hours. The pressure of blast ranges up to above 20 pounds per square inch, its temperature to 1000° or 1500° F., and the product to 500 or 800 tons per twenty-four hours, 180,000 to 300,000 tons per year. (Figs. 6a, 6b.)

In the locality named, sizes of furnaces have been reduced

to about 75 feet (22.5 metres) high, and 27 feet (8.1 metres) in diameter as maxima, and in other places to considerably smaller dimensions.

84. **The Height of Furnace** is generally limited by the power of the materials charged to resist the pressure of the superincumbent mass as they approach the lower part of the furnace; and this limitation of height also limits the diameter of the shaft, as an excess in the latter dimension introduces a difficulty in securing a proper distribution of the ascending currents of reducing gases. The proper ratio of height to maximum diameter is fixed, by usual practice, at 3 in coke furnaces and at about 4 in anthracite furnaces. After reaching a certain altitude, also, no useful gain is secured by this transfer of heat from the gases to the material in the upper part of the stack.

85. **Temperature of Furnace.**—Bell presents the adjacent figure as illustrating the distribution of work and adjustment of temperatures in the blast furnace; the temperature falling as the rising gases flow through the successive zones of fusion of the reduced metal, of absorption of carbon, calcining of limestone, and of reduction of ore, from a white to a dull red heat, and finally issue still hot and pass off to the stove.

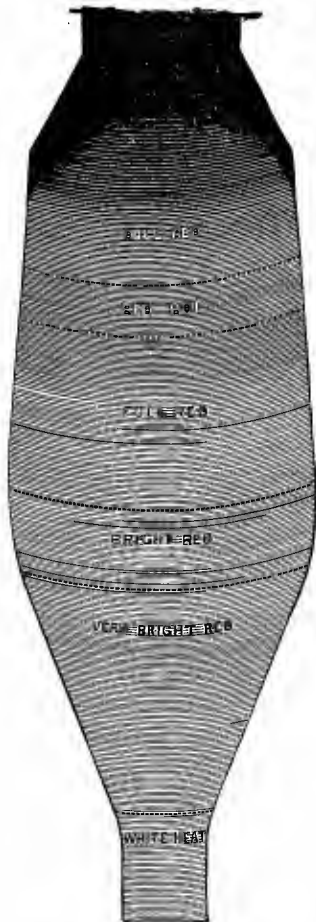

FIG. 7.—TEMPERATURES OF FURNACE.

The proportions of furnace to produce maximum efficiency in yield and economy will vary somewhat in every locality. The accompanying diagram, Fig. 8, is given by Bell as

indicating the rate of increase of economy observed by him with increase of size of furnace.

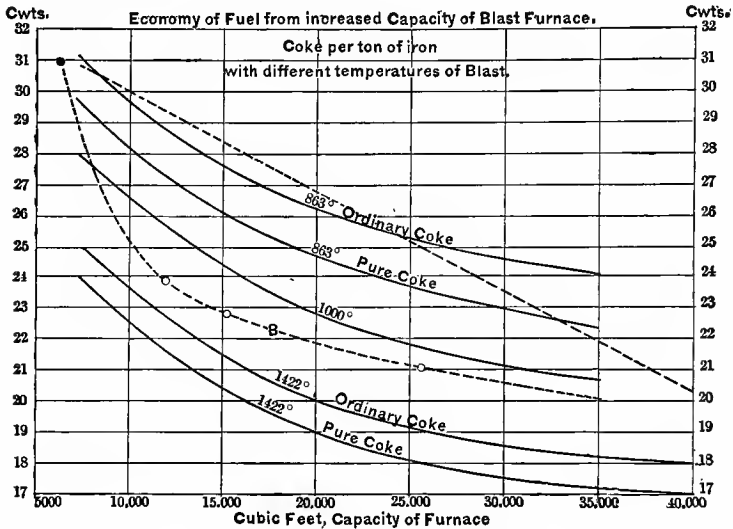

FIG. 8.—ECONOMY OF FURNACE.

It will be noticed that the increase is rapid with small sizes, and that it becomes less and less as the size is increased, and continually approaches a maximum at which this benefit disappears. It is also seen that (Fig 8), temperature of blast

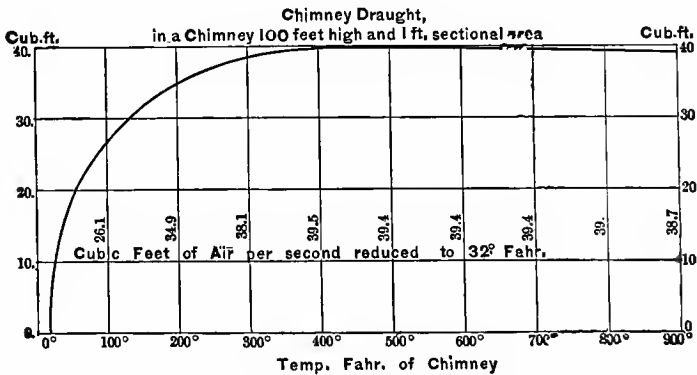

FIG. 9.—TEMPERATURE OF CHIMNEY.

and draught affect the rate of increase. The greatest economy is obtained with pure coke, maximum temperature of blast, and a maximum of 40,000 cubic feet (1,132.8 cubic metres) capacity of furnace, under which conditions a ton of iron is made with 17 cwt. (77.27 kilos.) of coke.

86. The Temperature of the Blast has an influence upon the economy and yield of furnace, which is also limited in its value. In this case the limits are determined by three conditions.

The benefit derivable from increasing temperature of blast becomes less and less as the higher temperatures attainable are approached. After a time a temperature is reached beyond which it would not be found economical to go, the increased advantage in saving fuel and increased yield being compensated by increase in various running expenses.

The elevation of temperature of blast is also limited by the power of endurance of the materials composing the hot-blast stove and the pipes. A cast-iron pipe cannot sustain a temperature much exceeding 1,112° Fahr. (600° Cent.), for long periods of time. Fire-brick stoves may, however, be used to vastly higher temperature, 1,600° Fahr. (871° Cent.) having been actually attained.

The temperature attainable in the stove is further limited by the quantity and quality of the combustible gases coming from the stack. This limit of temperature will vary with every change of air supply also.

The heating power of the gases and the maximum temperature possible can be readily ascertained when the composition of the gases and the character of the air supply is known, by the method of which the following case, given by Kent, is an illustration. Take as composition of waste gases.

Carbonic oxide	30.25
Carbonic acid	9.30
Nitrogen	58.78
Hydrogen, water, and volatile matter.....	1.67
	<hr/>
	100.00

These are supposed to have a heating power sufficient to

raise steam for the engines and to heat the blast. The heating power is derived from two sources: 1st. Their sensible heat; and, 2d. The combustion of their carbonic oxide.

Assuming the gases, as they reach the boilers and ovens, to have a temperature of 500° Fahr. (260° Cent.), we arrive at a measure of their heating power, as follows:

The specific heat of the gases is found by multiplying the percentage of each constituent by its own specific heat, and adding the results. thus:

CO.....	30.25 × 0.2479 =	7.499
CO ₂	9.30 × 0.2164 =	2.013
N.....	58.78 × 0.2440 =	14.342
H ₂ O.....	1.67 × 0.480 =	0.802
	100.	24.656

Whence the specific heat = 0.246

The heating power due to the temperature, then, is $468 \times 0.246 = 115.15$ British thermal units per pound. The heating power due to the combustion is $\frac{30.25}{100} \times 4,325 = 1,308.31$ British thermal units per pound (4,325 being the heat of combustion of CO according to Favre and Silbermann). The weight of the gases discharged per minute being 650.02 pounds, their total heating power above 32° Fahr. is $650.02 \times (115.13 + 1,308.31) = 925,264.47$ British thermal units.

The amount of air theoretically necessary to burn these gases is that whose oxygen is just sufficient to burn the CO to CO₂, or 0.1729 pounds of oxygen per pound of gas. The air corresponding to this is $0.1729 \times \frac{100}{23.01} = 0.7514$ pounds. The amount *actually* required in practice is at present unknown, for there appear to have been no experiments made on the subject, nor are there any analyses on record of the escaping gases in the chimneys of the boilers or ovens, from which such amount might be calculated.

It is asserted by various authorities on combustion, that in ordinary coal fires from $1\frac{3}{4}$ times to twice as much air should be supplied as is necessary to burn the carbon of the fuel to carbonic acid.

Assuming a like figure in the present case, viz., that twice as much air is required to burn the gas as is theoretically necessary, or $.7514 \times 2 = 1.5028$ pounds per pound of the gas, we have a means of arriving at the probable temperature of the fire in the ovens and under the boilers. The elevation of temperature of the fire above the temperature at which the air and fuel are supplied to the furnace may be computed by dividing the total heat of combustion of one pound of fuel by the weight and the specific heat of the whole products of its combustion, and of the air employed for their dilution under constant pressure. We have:

$$\text{Elevation of temperature} = \frac{1308.31}{1 \times 0.24656 + 1.5028 \times 0.2377} = 2167^\circ \text{ Fahr.}$$

To this must be added the average temperature of the gases and the air supplied (the latter say at 60° Fahr., 15° Cent.), which is

$$\frac{1 \times 500^\circ + 1.5028 \times 60}{2.5028} = 236^\circ \text{ Fahr. (111}^\circ \text{ Cent.).}$$

The temperature of the fire is, therefore,

$$2167 + 236 = 2402^\circ \text{ Fahr. (1311}^\circ \text{ Cent.),}$$

which is far above the temperature of ignition of the waste gases.

If by more economical working of the furnace itself the ratio $\frac{CO_2}{CO}$ be increased, the temperature of the fire will be diminished, as will also the heating power of the gases. Although then the ratio $\frac{CO_2}{CO}$ is the index of the calorific efficiency of the furnace, as stated by Bell and Gruner, it must by no means be so much increased as to render the gases either incombustible or of insufficient heating power.

The gases issuing from the top of furnaces having an exceptionally high temperature of blast, are cooler than those issuing from furnaces having a colder blast. This fact also

assists in producing a limit of temperature. The fact is due to the reception of the larger proportion of heat in the former furnace, from its blast, and the less proportion from combustion. Combustion also involves less gas, and the smaller volume is more completely cooled in rising through the furnace. The minimum temperature of gases tends to remain constant at about 392° Fahr. (200° Cent.), according to Gruner, in consequence of the regulating effect of the dissociation of the carbonic oxide, which can only occur above a fixed limit. The maximum temperature of blast, with even fire-brick stoves, may be taken at about the higher figure above given.

The accompanying graphic representation, Fig. 10, is

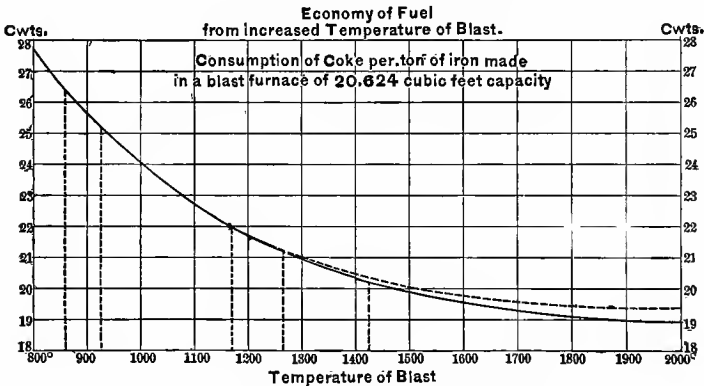

FIG. 10.—ECONOMY OF HIGH TEMPERATURES.

given by Bell, illustrating the gradual approximation to a maximum of the benefit derivable from increasing temperature of blast.

It represents the consumption of coke per ton (1,016 kilogrammes) of iron made in a furnace of 25,624 cubic feet (724.7 cubic metres) capacity. The figures corresponding to 800° , 925° , 1175° , 1275° , and 1425° Fahr. (450° , 490° , 591° , 630° , and 768° Cent.) are observed; all others are determined by plotting the curve.

The benefit of increasing the temperature of blast is least marked in furnaces of great height used for smelting ores which are easy of reduction.

The cause of the increased economy following elevation of temperature of blast is considered to be principally the decreased volume of air demanded, and its consequent still further increase of temperature above that obtainable when the heat is derived from combustion. In the latter case the heat is distributed throughout the large volume of nitrogen entering with the supporter of combustion, and the temperature reduced by this dilution.

In general, the smaller the quantity of material, whether solid or gaseous, passing through the furnace with a given production of iron, the less the expenditure of heat, and hence the less the cost of reduction of the ore. The smaller the mass, also, the more the time allowed for the chemical reaction, and the more complete those changes.

The larger and more economical furnaces utilize about 85 per cent. of the heat generated, or, as stated by Gruner, about 75 per cent. of the available heating capacity of the fuel.

87. A considerable Loss in the Efficiency of a blast furnace occurs through leakages, etc., about the pipes and tuyeres. From experiments made by Mr. J. M. Hartman, on a new plant in good order, and communicated to the Author, the following table of constant leakages is obtained :

With	2 lbs. pressure	5 per cent. of displacement of blowing piston.
"	4 lbs.	" 10 "
"	6 lbs.	" 15 "
"	8 lbs.	" 20 "
"	10 lbs.	" 25 "

If the loss in leakages exceeds these figures, a careful examination should be made with a view to stopping them.

The total value of 10,000 feet (283.25 cubic metres) of air per minute, compressed to one and a half atmospheres, and heated, is \$119 for 24 hours, or say \$5 per hour. If the loss in leakage with this volume of air is 25 per cent. over the figures given in the table, then there is a daily loss of about \$24 in a useless expenditure of heat and power, with a further loss of 20 per cent. in the yield of the furnace.

88. Kent* gives the following as the record of a blast furnace for one month, which may be taken as the work of an anthracite furnace of average economy, but of small size :

TABLE XXXII.
RECORD OF A BLAST-FURNACE FOR ONE MONTH.

DAY.	CHARGES.						REVOLUTIONS OF ENGINE PER MINUTE	BLAST.		PRODUCT.			ATMOSPHERE.			BURDEN. Ore and Limestone.
	Coal.		Ore.		Lime-stone.			Pressure. lbs.	Heat.	Tons.	Cwt.	Average grade.	Tempera- ture.	Barom- eter.	Moisture, per cent.	
	Tons.	Cwt.	Tons.	Cwt.	Tons.	Cwt.										
1	31	10	48	6	13	10	22	6½	740	21	15	1.49	48.0	29.96	0.68	2300.644
2	32	5	49	9	13	16	22	6½	740	26	5	1.72	42.7	29.95	0.71	2200.644
3	31	10	46	11	13	10	22	6½	740	24	10	1.11	40.0	30.04	0.68	2150.652
4	31	10	45	9	13	14	22	6½	740	24	.	2.00	39.6	30.22	0.52
5	30	15	44	2	13	7	22	6½	740	25	10	1.17	39.7	29.97	0.52
6	30	15	44	2	13	7	22	6½	740	22	15	1.00	37.3	29.92	0.51
7	31	10	45	3	13	14	22	6½	740	24	5	1.12	39.7	29.84	0.57	2300.652
8	30	..	45	11	13	..	22	6½	740	21	10	1.09	35.0	29.97	0.46
9	30	..	46	..	13	..	22	6½	740	25	5	1.08	31.3	30.03	0.46
10	30	..	46	..	13	..	22	6½	740	24	..	1.12	35.0	30.07	0.46
11	32	5	49	9	14	..	22	6½	740	21	15	1.41	40.0	30.11	0.47
12	30	15	47	3	13	7	22	6½	740	24	..	1.04	41.7	29.94	0.53
13	31	10	48	6	13	14	22	6½	740	24	5	1.10	22.0	30.25	0.32
14	31	10	48	6	13	14	22	6½	740	24	10	1.12	27.7	30.37	0.38
15	31	10	48	6	13	14	22	6½	740	24	5	1.18	36.6	30.20	0.43
16	30	15	47	3	13	7	22	6½	740	24	15	1.08	42.7	29.92	0.61
17	30	15	47	3	13	7	22	6½	740	23	15	1.15	39.6	29.70	0.43
18	30	15	47	3	13	7	22	6½	740	22	..	1.40	31.0	29.73	0.40
19	27	15	42	11	13	..	22	6½	740	21	10	1.13	31.0	29.67	0.52
20	30	..	46	..	13	..	22	6½	740	20	5	1.51	28.7	29.79	0.52
21	30	15	47	3	13	7	22	6½	740	25	10	1.42	42.0	29.67	0.50
22	31	10	48	6	13	14	22	6½	740	24	15	2.16	48.0	29.77	0.50
23	30	..	46	..	13	..	21½	6	740	24	5	2.00	38.3	29.77	0.61
24	30	15	47	3	13	7	22	6½	740	23	5	1.75	35.3	29.37	0.62
25	30	15	47	3	13	7	21	5¾	740	23	5	2.47	36.7	29.63	0.55
26	32	5	49	9	14	..	21	5¾	740	24	5	2.65	38.0	29.95	0.51
27	31	10	45	11	12	18	21	5¾	740	24	5	1.37	38.7	30.03	0.45	2100.609
28	32	5	49	9	13	15	21	5¾	740	24	..	1.22	39.6	30.02	0.43	2300.644
29	30	15	47	3	13	7	21	5¾	740	23	5	1.11	44.0	30.07	0.49
30	31	10	48	6	13	14	21	5¾	740	24	5	1.70	48.0	29.64	0.88

89. The Cinder or Slag issuing from the blast furnace is a kind of impure glass. It is usually opaque and deeply colored, but is sometimes transparent, and is occasionally perfectly white. Its colors vary from a deep brown or black to a barely perceptible tint of purple ; it is often green, gray, or blue. In structure it is sometimes compact and strong,

* Graphic Method of keeping the Record of working a Blast Furnace, read before the American Institute of Mining Engineers, at the Amenia meeting, October, 1877.

closely resembling stone, and sometimes light, spongy, and friable, like pumice.

When black or green, it contains iron, or iron and manganese; if purple and translucent, manganese is present; a blue color indicates sulphur, and blistered slags are said to contain titanium.

A good quality of cinder is fluid, free from iron, usually grayish in color, stony in fracture when cold, and does not chill rapidly.

When possible, the fusing temperature is brought closely to that of the iron; a higher melting point causes danger of congealing in the furnace; a lower temperature of fusion is apt to cause loss of iron by solution in the cinder.

An example of a good slag had the following approximate composition (see also p. 124):

Silica.....	44
Alumina.....	15
Lime.....	29
Magnesia.....	6
Iron oxide.....	2
Manganese.....	1
Potash.....	2
Sulphur and phosphorus.....	1
	100

The character of the slag is closely watched by the blast-furnace manager; from it he derives a knowledge of the manner in which his furnace is working.

Blast-furnace cinders are classified as monosilicates, bisilicates, trisilicates or subsilicates, but it is seen that they are generally double silicates of lime and alumina, with some admixture of silicate of magnesia and other bases, and holding in solution oxides of iron and manganese, and have a very wide range of composition.

When basic in character, they are of dull gray color and stony in structure, having a high temperature of fusion; they are only safely made in large furnaces with hot blast, but are best adapted to securing complete reduction and the production of foundry and Bessemer grades of cast iron. This kind also takes up more sulphur than do acid cinders.

The fusibility becomes greater with increase of the silica until its proportion reaches about sixty per cent.; when exceptionally rich in silica, the cinder takes up oxide of iron freely, and it is then called a "scouring cinder."

The blast-furnace cinder is usually run into iron tank cars and carried away to be used as filling, or dumped wherever its presence will be least likely to be objectionable. It is sometimes carried away by a stream of running water, into which it falls from the extremity of the cinder-trough. No completely successful scheme has yet been devised for its utilization, although it has sometimes been used for building blocks, paving, and in mortar and cements, and as a non-conducting protector for heated masses.

The following analyses illustrate the variety of composition which is observed in furnace cinder: A is a slag from a charcoal furnace using rich and pure ores, B from an anthracite furnace making gray forge pig, C from a furnace using soft coal and making gray iron, D from a similar furnace making white iron, E from a coke furnace making gray iron. The last three were using ores containing sulphur.

TABLE XXXIII.
COMPOSITION OF SLAGS.

	A.	B.	C.	D.	E.
Silica.....	61.0	43.1	38.5	43.1	27.5
Lime.....	20.0	32.0	33.4	30.0	39.0
Alumina.....	5.5	14.0	14.4	15.0	24.8
Oxide of iron.....	3.3	1.4	0.8	2.5	0.8
“ “ manganese.....	2.6	1.5	1.5	1.5	0.4
“ “ magnesia.....	7.1	7.5	7.5	5.0	3.5
Calcic sulphide.....	0.5	2.4	2.0	1.8
Potash.....	1.5	1.4	1.5
Phosphoric acid.....	0.2	0.3
	99.5	100.0	100.2	100.5	99.6

Cinder flowing from the furnace carries away from 1,600 to 2,000 British thermal units of heat per pound.

90. The Iron tapped from the Furnace is led by properly

arranged channels to the "pig bed." This is usually a considerable area of sand leveled off and scored longitudinally and transversely to form moulds. The main channel, called the "sow," of each section, has on each side smaller channels of about four feet (1.22 metres) length, in each of which a "pig" is cast. The whole arrangement resembles somewhat that of a gridiron. When forge iron of high grade is to be made, the pig metal is often cast in iron moulds instead of in sand, to avoid the introduction of silicon. The pig bed is covered by a roof to protect it from the weather. This "casting-house" is built close against the stack of the furnace.

When the metal has cooled in the pig bed, the pigs are broken from the sow and are stacked in the yard, or are sent off to market after they have been graded, numbered, and distributed into lots of similar quality. The sow is sometimes also sent to market after it has been broken into pieces of proper size to handle; in other cases it is charged into the furnace and remelted.

The iron having been removed, the pig bed is made up anew ready for the next cast.

The casting-house is usually built of substantial and fire-proof materials. Brick walls and an iron roof are adopted when the expense can be met without serious inconvenience.

The gases are taken from the top of the furnace through a sheet-iron pipe leading out at the side, under the charging floor, and led to the hot-blast stoves and to the steam boilers. The gas main is lined with fire-brick to prevent escape of heat and to prevent rapid oxidation of the iron pipe at the comparatively high temperature which would be given it by direct contact with the heated gases. The gas main is sometimes carried some distance a little above or below ground to the stoves.

91. The Hot-blast Stoves or ovens are of either iron or brick. The former consist of sets of cast-iron pipes of various forms and variously arranged in different cases, inclosed in large chambers lined with fire-brick. The blast is driven through the pipes, which are kept heated by the burning

gases from the furnace, which latter are inflamed in the inclosing chamber.

In some forms of stove the gases are burned in a "combustion chamber," and the heated products of combustion rise into an upper chamber containing the set of pipes carrying the blast. This system is claimed to possess the advantage of giving greater uniformity of heat and less danger of cracking the pipes by sudden and great changes of temperature.

In other forms, the gas is burned in contact with the pipes, and but one chamber is used.

The forms of pipe adopted are very numerous. In some ovens, mains are led across the chamber parallel with its sides. The blast enters one main and passes over into the other through a set of **n**-shaped pipes, emerging from the second main, whence it is conducted to the tuyeres. The intermediate pipes are usually of elliptical or oval section, having the longer diameter in line with the mains. This form permits expansion and contraction with change of temperature to take place with little danger of frequent fracture of the pipes.

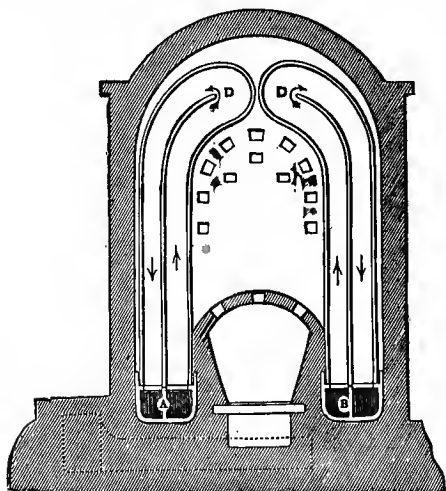

FIG. 11.—“PISTOL-PIPES.”

In other forms of cast-iron pipes, they are divided by a diaphragm into two parts. The air is led into the main, rises into one of these chambers, returns through the other to the main, which it traverses until reaching the next pipe, it enters that, and thus passes from pipe to pipe until it emerges at the extremity of the main fully heated. In such stoves, several mains are laid down, each carrying a set of these double pipes.

A modification of this form of pipe which has been found

to work well is that known as the "pistol-pipe," in which the upper extremity is enlarged, giving the pipe the shape of a pistol erected muzzle downward, the well at the top of the pipe representing the butt, Fig. 11. This form permits a reduced velocity of gas at the top of the pipe, and gives an increased area of heating surface; opposite pipes have their tops turned toward each other, forming an arch above the chamber through which the hot products of combustion are rising, and the whole makes a very efficient form of stove.

A recent form of stove is fitted with iron pipes suspended from above, instead of being supported from beneath. It is stated that this modification increases the durability of iron pipes very greatly.

The least area of heating surface required to give the maximum temperature permanently sustainable by cast-iron pipes is considered by some engineers to be from 1,000 to 1,200 square feet per 1,000 cubic feet (3.26 to 3.9 square metres per cubic metre) of air passing per minute; the proportion is often much less. A pair of furnaces having three blowing engines of 84 inches (213 centimetres) diameter of blowing cylinders and 5 feet (4.57 metres) stroke of piston and making 20 to 30 double strokes per minute, when fitted up with twelve stoves, each containing 14 double pipes 16 feet (14.16 metres) long, 19 inches (48.26 centimetres) wide, and 5 inches (12.7 centimetres) deep, received the blast at a temperature of 1,130° Fahr. (610° Cent.). In this example each stove had a separate chimney.

The limit of temperature with iron stoves is so low that, at many furnaces, stoves are now built of fire-brick throughout, including heating surfaces. These are comparatively expensive, but they have been used with a blast heated to 1,382° Fahr. (750° Cent.), and even 1,742 Fahr. (950° Cent.) has been attained at times. When these stoves are constructed in such form that they are not liable to become choked with the dust carried over with the combustible gases, they are found to give excellent results. These stoves are usually constructed upon the principle of the regenerative, or the fire-brick furnace, as, for example, in the stoves of

Cowper and Whitwell. In the Sellers regenerator, the action is continuous, as in the cast-iron stoves, and the structure is, like them, composed of pipes. The material of the pipe is a refractory clay.

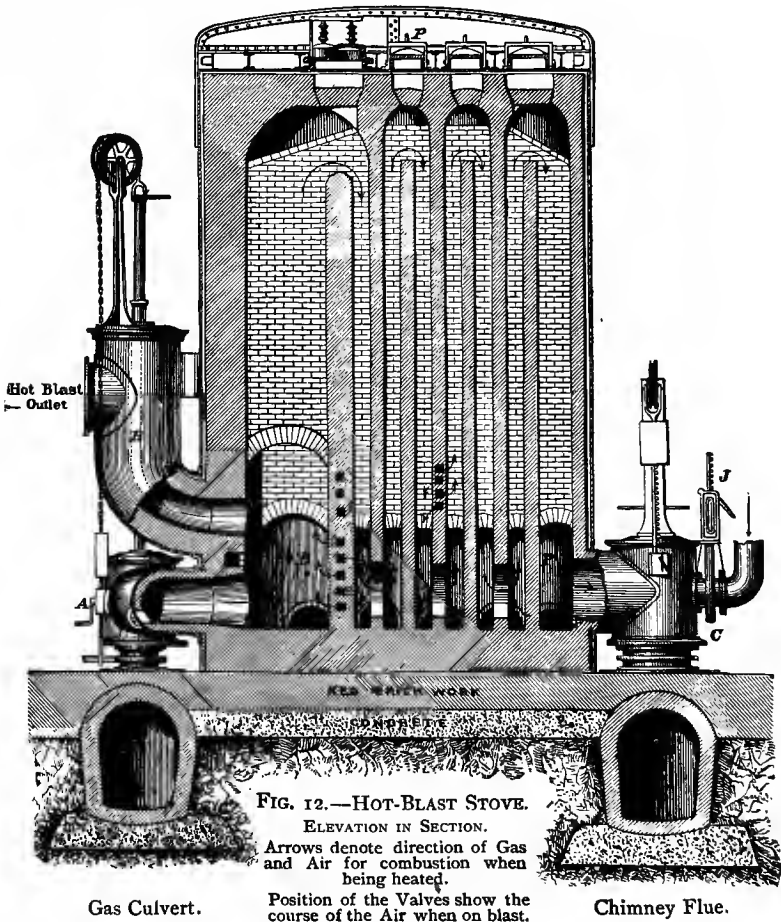

The fire-brick stoves must usually be given two or three times greater area of heating surface than cast-iron stoves. The weight of brick used is about one ton (1,106 kilogrammes)

for each 20 square feet (1.8 square metres) of heating surface.

92. The Whitwell Stove (Figs. 12, 13) is a modification of the regenerative apparatus used in gas furnaces, and its

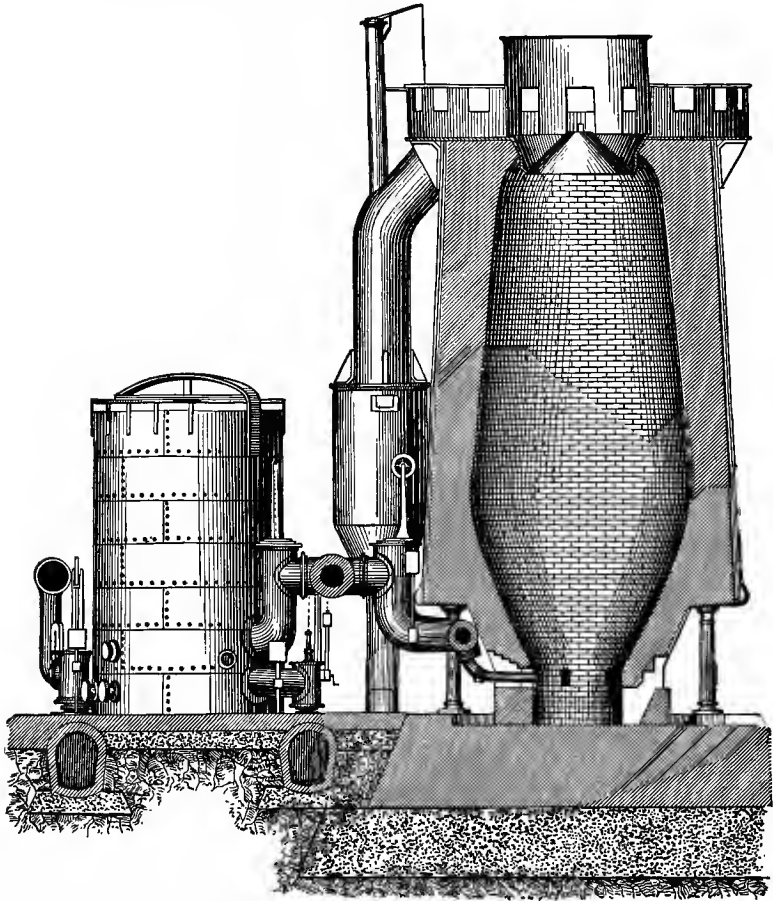

FIG. 13.—ANTHRACITE BLAST FURNACE, GAS TUBING, HOT-BLAST MAIN, AND STOVES.

method of operation is very similar. They are stated to bear the highest attainable temperature, to be free from lia-

bility to wear and tear, easily cleaned even when hot, free from leakage, to produce no loss of pressure of blast, to be very efficient regulators of temperatures, and to secure great economy over iron stoves. For a production of 6,000 tons (6,096,000 kilogrammes) per month, two of these stoves are fitted, each of about 6,000 cubic feet (170.00 metres) volume and of 10,000 to 15,000 square feet (950 to 1,425 square metres) of heating surface.

93. Blowing Machinery.—The blast is forced into the blast-mains by blowing machinery driven either by water or steam; the latter is the usual motor.

The steam cylinder and blowing cylinder are generally parts of one machine, which is called the blowing-engine. In the most common, and in some respects best, form the cylinders are vertical, the air cylinder above the steam cylinder, and the pistons have a common rod. A large fly-wheel is used to insure a uniform motion. The ratio of piston area is determined by the relative mean pressures on the two pistons. A blowing-engine having steam cylinders 45 inches (143 centimetres) diameter and air cylinders 72 inches (183 centimetres) diameter, making 14 revolutions per minute, took in about 200,000 cubic feet (5,632 metres) of air per hour and delivered it under a pressure, at the tuyeres, of 4 pounds per square inch (0.28 kilogrammes per square centimetre), drawing steam from four plain cylinder steam boilers 5 feet (1.5 metres) in diameter each and 36 feet (10.8 metres) long. The furnace was 66 feet (20 metres) high, 17 feet (5.1 metres) in diameter of bosh, had 5 tuyeres 6 inches (15 centimetres) diameter inside supplied with a blast heated to about 932° Fahr., (500° Cent.). The stoves were of cast iron, three in number, and contained, each, 24 pipes 14 feet (4.2 metres) long, and 9 inches (22½ centimetres) internal diameter. The speed of piston is usually, in Pennsylvania, not far from 225 feet (67.5 metres) per minute but rises to 300.

Blowing engines are often built with a beam mounted on columns and linked to the piston of a vertical steam cylinder at one end, and to that of a blowing cylinder at the other. Horizontal blowing engines are also sometimes built. En-

gines of the latter class have sometimes been constructed like steam pumps without fly-wheel, which, notwithstanding some irregularity of motion, are said to perform well.

Blowing engines have been built having air cylinders as large as 12 feet (3.6 metres) in diameter, and with a stroke of 12 feet (3.6 metres) in length, which, making 19 strokes per minute, delivered more than 50,000 cubic feet (1,416 cubic metres) of air per minute against a pressure of 3 pounds per square inch. Pressures now often attain 25 pounds.

The size of blast mains should be made so great that the resistance due to friction should be small, and that they may serve as reservoirs to equalize the pressure of blast. A diameter of from one third to one half that of the blowing cylinders is adopted. The full area of section should be preserved in the valve passages and up to the tuyeres. If Q is the quantity of air supplied per minute, the diameter

may be taken $d = \frac{\sqrt{Q}}{3}$ inches. Safety valves should be fitted

to relieve the pipes from excess of pressure. Stop valves in the pipes enable the attendants to shut off or modify the supply of air to either furnace.

The valves of the steam cylinders are like those of other simple forms of steam engine; those of the blowing cylinders are sometimes slide-valves of metal, but usually flap-valves of leather or vulcanized caoutchouc.

94. Estimating the Air Supply to be obtained from a set of blowing cylinders of which the dimensions are known, is thus performed: Let A = area of blowing cylinder piston in square feet; C = length of stroke in feet; R = number of revolutions of engine or double strokes of piston, per minute; v = volume of air expelled at each revolution, in cubic feet; V = volume of air entering blowing cylinder per minute; V' = volume of air entering reservoir per minute; V'' = volume of air entering furnace per minute; p = pressure of external air in pounds per square inch above a vacuum; p' = pressure in the reservoir in pounds per square inch above a vacuum; p'' = pressure at the furnace in pounds per square inch above

a vacuum. Then $V = 2ALR$; $V' = vR = mV$, in which m has the following values at the pressure p' :

BRITISH p' .	ATMOS- PHERES.	m .	BRITISH p' .	ATMOS- PHERES.	m .
15	1.05	0.986	20	1.40	0.801
16	1.12	0.942	21	1.47	0.776
17	1.19	0.902	22	1.54	0.751
18	1.26	0.866	23	1.61	0.728
19	1.33	0.834	24	1.68	0.706

The air reduced by compression from the volume V to $V' = mV$, passes through the mains to the hot-blast ovens, and is heated to a high temperature and considerably increased in volume. While passing from the blowing-engine to the stoves it loses some of the heat due to compression, which loss is partially compensated by the increase of temperature due to frictional resistance in the pipe.

If A = area of frictional surface in square feet;

V = velocity of current in feet per second;

H = weight of a cubic foot of the flowing gas in pounds;

A' = cross-sectional area of pipe in square inches;

t = loss of pressure in pounds per square inch;

$$t = 0.0001 \frac{AHV^2}{A'}, \text{ nearly;}$$

or, in metric measures, kilogrammes, and centimetres,

$$t_m = 0.000004 \frac{A_m H_m V_m^2}{A_m}, \text{ nearly.}$$

Assuming the total loss of temperature to be practically unimportant, the volume V' reaches the stoves at a tempera-

ture exceeding that of the external atmosphere, if at 60° Fahr. (27° Cent.), as below :

BRITISH. ϕ'	ATMOSPHERES.	INCREASE.	ϕ'	AT.	INCREASE.
15	1.05	3.16° Fahr. (1.76° Cent.)	20	1.40	48.76° Fahr. (27.10° Cent.)
16	1.12	12.97° Fahr. (7.21° Cent.)	21	1.47	56.80° Fahr. (31.55° Cent.)
17	1.19	22.44° Fahr. (12.37° Cent.)	22	1.54	64.65° Fahr. (35.92° Cent.)
18	1.26	31.53° Fahr. (17.51° Cent.)	23	1.61	72.25° Fahr. (40.15° Cent.)
19	1.33	40.27° Fahr. (23.37° Cent.)	24	1.68	79.83° Fahr. (44.35° Cent.)

Let

T = the absolute temperature on entering the oven,

T' = the absolute temperature on emerging.

[The absolute temperature is obtained by adding to temperatures Fahrenheit 461.2°, and to temperatures on the Centigrade scale, 273°.]

The volume of air issuing from the hot-blast apparatus will then be

$$V'' = nV'$$

in which

$$n = \frac{T'}{T}.$$

The coefficient of dilatation of air and other permanent gases by heat is, under constant pressure, .003665 for the Centigrade scale, and .002036 per degree Fahrenheit.

The effective area of tuyere opening must evidently be equal to the quotient of the volume of air passing per minute divided by its velocity. The actual area will be the effective area thus found divided by the coefficient of contraction, which is from 0.92 to 0.95.

The engine-power required to furnish the supply of air demanded is estimated by obtaining the product of the volume of air passing into the blowing cylinders per minute by the mean pressure plus from one to two pounds excess due to

frictional resistance in the engine and the resistance of valves, and dividing this quantity by the work done per minute by a horse-power (33,000 foot-pounds or 4,500 kilogram-metres).

If R = revolutions per minute, A = area of air-cylinder piston in square inches, L = length of stroke in feet, P = the pressure of the atmosphere, P' = the pressure of blast at its exit from the blowing cylinder, in pounds per square inch, the horse power,

$$HP = \frac{2RALP \left(1 + \text{hyp log } \frac{P'}{P} \right)}{33,000}, \text{ nearly.}$$

In metric measures, kilogrammes and centimetres,

$$HP_m = 0.0005 \left[2RA_m L_m P_m \left(1 + \text{hyp log } \frac{P'_m}{P_m} \right) \right], \text{ nearly,}$$

and the size of steam piston is $A = \frac{33,000 HP}{2 P'' LR}$ when P'' is the mean steam pressure.

The quantity of air required will vary from 500,000 (41,160 cubic metres) to 1,000,000 cubic feet (82,320 cubic metres) in good furnaces, per ton of iron made. The lower figure represents good performance with rich, fusible ore, and the latter quantity is required when the ores are lean and refractory. A good anthracite furnace, running on ores yielding 50 per cent. iron, and requiring three-fourths their weight of flux and fully their weight of fuel, required over 800,000 cubic feet (22,656 cubic metres) of air, or about 400,000 cubic feet per ton of coal (11,328 cubic metres per 1,016 kilogrammes), and from 7.5 to 15 pounds per pound of iron made. A pound of air at 32° Fahr. (0° Cent.) and at atmospheric pressure has a volume of 12.4 cubic feet. A kilogramme of air measures 0.77 cubic metre.

95. Hoists or Elevators.—The material charged into the furnace is raised to the charging floor by hoists or elevators, which are operated by ropes and winding-drums, by water, or by steam or pneumatic pressure. The last two forms seem usually preferred.

The *Winding-Drum*, when used, is usually turned by a pair of small, quick-working steam-engines. The rope is about $\frac{3}{4}$ inch (1.9 centimetres) in diameter, of steel or iron wire. A brake controls the drum and gives the attendant control of the platform when descending. All parts should be given a large factor of safety.

An inclined plane was formerly very frequently built for the hoistway, and the charges were raised in wagons running on rails.

The *Water-Bucket Hoist* consists of a set of timber supports and guides, at the top of which are pulleys carrying the rope or chain, which, at one end, is attached to the traveling platform or cage of the hoist, and at the other is secured to a large "bucket." Both bucket and platform are guided by the timber frame of the hoist. The bucket is alternately filled and emptied, receiving its water from a reservoir at the level of the charging floor and discharging its contents into another reservoir, or into a tail-race at the bottom of the hoist. The motion of bucket and cage is controlled by a brake, and latches at top and bottom hold them when they are to be kept stationary. The bucket and cage may be made of either wood or iron, the latter being preferred.

Water is supplied from some natural or artificial source, by gravity or by force pumps, or through hydrant pipes.

The supply-cock of the reservoir and the discharging-cock of the bucket are usually opened and closed by hand.

When the bucket is at the top, the cage is at the bottom of the hoist. When filled with water, the former overbalances the weight of the latter and its load, and, being unlatched, descends, pulling up the loaded platform with which it is connected by the rope or chain passing over the pulleys at the top. When the charges have been thrown into the furnace, the unloaded barrows are wheeled back upon the platform.

Meantime the bucket has been emptied, and the weight of the cage now preponderating, it descends, raising the empty bucket to the top.

This apparatus is simple in construction and durable, but

it is heavy, slow in operation, and quite bulky. It is much less used than formerly. From 20 to 50 per cent. of the whole energy of the water supply is wasted by friction and loss of head.

The *Plunger Hoist*, or water-pressure hoist, is a hydraulic press which either carries the platform directly or raises it through the intervention of pulleys and tackles. In the first, a strong hollow iron cylinder, of a length somewhat exceeding the height through which the platform is to be raised, is sunk into the earth in a vertical position. Water, under a pressure of sometimes 300 or 400 pounds per square inch (21 to 28 kilogrammes per square centimetre), is led from forcing pumps, or from an "accumulator," into this cylinder, and forces up a "plunger," which is fitted to the latter, and which carries the platform. The lower end of the cylinder is closed, the upper end is fitted with a stuffing-box, or a collar packing which prevents leakage as the plunger slides vertically through it.

The load at the plunger is equal to the weight of useful maximum load added to the weight of plunger and platform plus the frictional resistance to sliding, which varies somewhat, but which may be taken at one-tenth. Calling W = the maximum load, and W' = the weight of the moving parts of the hoist in pounds, d = the diameter of the plunger in inches, and p = the available pressure of water in the cylinder of the press in pounds per square inch,

$$d = \sqrt{1.1 \frac{W + W'}{\frac{1}{4} p \pi}} = 1.2 \sqrt{\frac{W + W'}{p}}, \text{ nearly.}$$

The accumulator consists of a heavily weighted plunger of considerable volume rising and falling under its load in a cylinder like that of the hydraulic press. A set of pumps driven continuously forces water into the accumulator, while it is drawn out intermittently by the working apparatus to which the water is supplied. This accumulator, or store-cylinder, must have such volume that it shall not be exhausted completely at any time, and its plunger must be loaded with the weight needed to preserve the maximum pressure desired.

By its use, small pumps and a small prime-motor acting continuously are enabled to supply water, which is drawn by the hoist in comparatively large volumes and intermittently, thus securing economy of maintenance, and, usually, of first cost. The accumulator is also useful as a safety-valve.

The connecting pipes should be made as large as is consistent with economy of cost, to reduce frictional losses. The velocity of the hoist is variable; one foot (0.3 metre) per second is a speed sometimes adopted. The expenditure of power at the pumps is frequently one-half greater than that usefully applied by the hoist.

An empirical formula for thickness of water pipes, used by some engineers, is

$$t = 0.000055Hd + 0.5,$$

in which d is the diameter, t the thickness in inches, and H is the total maximum head of water in feet; for thickness and diameter in centimetres and head in metres we have

$$t = 0.0018Hd + 1.5, \text{ nearly.}$$

Pipes with sockets are generally used, although flanged pipes are common.

The thickness of hydraulic press cylinders, and of pipes, also, may be taken by Barlow's formula, which gives an excess of strength:

$$t = \frac{rp}{f - p},$$

in which t = the thickness in inches, r = the internal radius in inches, p = the assumed bursting pressure in pounds per square inch, and f = the tenacity of the material in pounds per square inch.

For radius and thickness in centimetres, strength and pressure in kilogrammes per square centimetre, we have

$$t = \frac{r p}{f - p}.$$

The form of hydraulic hoist with which pulleys are used requires a shorter plunger, and one of larger area than that just described, the two dimensions varying in inverse ratio and proportionally with the velocity-ratio of the pulley combination. A small additional frictional resistance must be allowed for. This form is of less first cost.

The pressures used are limited by circumstances. The maximum, as determined by the ultimate safe pressures for the material used, are, in hydraulic presses, about 4 tons (630 kilogrammes per square centimetre) for ordinary cast iron, 6 tons (940 kilogrammes per square centimetre) when lined with copper, and from 7 to 10 tons (1,090 to 1,560 kilogrammes per square centimetre) when made of wrought iron or steel.

96. The *Pneumatic*, or *Air Hoist*, consists of a cylinder of proper size traversed by a piston, which is connected by ropes, carried over large pulleys, to the platform of the hoist. By a pressure exceeding that of the atmosphere, on the one side, or sometimes by the creation of a partial vacuum on the other side, the piston is caused to move through the cylinder, raising the load. The cylinder must be nicely bored, and the piston well fitted and carefully packed. The pressure adopted is usually that of the blast of the furnace, and the air is, in such cases, supplied by the main blowing engines.

The diameter of the piston may be calculated as for the hydraulic hoist. The efficiency of this hoist is greater. In one of the best designs of this form of hoist the working cylinder stands in the middle of the hoistway, and there is a platform on each side, both of which move together. In other forms the cylinder has the platform built around it. In some cases, hoists are constructed having two platforms or cages so arranged that, while one is ascending the other is descending, and vice versa, balancing each other.

For a furnace using 1,000 tons (1,016,000 kilogrammes) of material per week, the elevator, or hoist, would be calculated to carry two barrows of 500 pounds (227 kilogrammes) each, or about 1,000 pounds (454 kilogrammes) total, and the cylinder would be about 30 inches (762 centimetres) in diameter, as usually designed. The platform may be calcu-

lated to rise with greater velocity than that of the hydraulic hoist.

This is the most generally approved form of furnace hoist.

97. The *Steam Hoist* is of similar form, and is worked by steam taken from the boilers supplying the blowing and pumping engines. In this class the piston often forms a counterbalance to the platform, and is, if necessary, weighted.

98. The **Water Supply** of the blast-furnace is an important detail. Water is required for the tuyeres, for the steam boilers and the condenser, and, frequently, for the hydraulic hoist and other minor accessories.

It is necessary to secure such a supply that the furnace may not be interrupted in the driest seasons. The required head is sometimes secured by a natural fall, sometimes by direct pumping, and sometimes by means of a large reservoir, at the required elevation, which is kept filled by forcing pumps. The water should be as pure as possible to avoid injury to boilers and to tuyeres by the formation of incrustation. Salts of lime are the most common impurities. They are removed to a greater or less extent, frequently, by heating, or by the use of chemicals, which render the precipitate pulverulent and readily removed, or which produce solutions which may be removed by occasional "blowing out" of the boiler, and which do not precipitate insoluble "scale."

99. The **Steam Boilers** are placed as near the engines as possible. The type may be, to some extent, a matter of choice, but they are usually of plain cylindrical form, set in brick-work, and fitted both with grates for use with solid fuel and with chambers and supply-conduits for gas from the furnace-top.

The extent of heating surface is determined by the quantity of steam required by the pumps and blowing engines. This amount is variable, but may be taken with ordinarily good machinery, as equivalent to about 35 pounds of water evaporated per hour per horse-power (15.64 kilogrammes per cheval). As a maximum, a square foot of heating surface for each six pounds of water (or about one square metre for each 30 kilogrammes) per hour may be given for solid fuel. With

gas, the lower temperature of fire usually compels the use of more boiler surface. One square foot of heating-surface to each two pounds (one square metre for each 10 kilogrammes) of water per hour is not unusual, the range of practice falling between fifteen and twenty square feet of heating surface per horse-power (1.3 to 1.8 square metres per cheval) of blowing engines.

The boilers should be well constructed of iron boiler plate, having a tenacity of about 55,000 pounds per square inch (3,850 kilogrammes per square centimetre) of section, and moderately ductile; or better of steel, containing less than 0.3 per cent. of carbon, and having a tenacity of about 60,000 pounds per square inch (4,221 kilogrammes per square centimetre) and a ductility equal to that of the best iron. It should soften when heated, and suddenly cooled; if it hardens, as does tool-steel, it is too hard, and contains too much carbon.

The boilers should have a factor of safety, when new, of at least six, and it should not be allowed to become seriously weakened by corrosion, or other form of injury.

Each boiler should have its own safety-valve, a steam-gauge, and a reliable means of determining the height of water within it. The usual causes of injury and of explosions are corrosion, low water, and faulty safety-valves and steam-gauges, which permit excessive pressure without giving relief to it or indicating its existence. "Low water detectors," and "high pressure alarms," which call attention to these dangerous conditions, are often used.

Provision should be carefully made to secure complete combustion of the fuel without excessive air-supply, the best possible protection against corrosion, accessibility for inspection, cleaning and repairs, and intelligent and careful management. Inspection should take place at regular and frequent intervals, and the boilers should at all times be kept in thorough repair.

100. The Stock-Houses are built as near the furnace as possible, and their size depends upon the amount of available capital, the method of obtaining the materials of the furnace

charge, the climate, cost of building material, and of land and other conditions.

A stock-house of sufficient size to contain one month's stock, is a usual size. The building is best built of brick, with an iron roof, if the size of the furnace and the financial condition of the proprietors permit. In calculating its dimensions, coal may be reckoned as occupying 40 cubic feet per ton (1.12 cubic metres per tonne), limestone 20 (0.56 metre per tonne), and ore from 15 to 25 (0.42 to 0.7 metre per tonne), according to quality and size. Separate bins are usually provided within the stock-house for the several qualities of ore, as well as for coal and limestone.

101. The General Arrangement of the furnace and its accessories is determined by local conditions, and by questions of finance. Furnaces are usually erected in pairs, where possible, with hoists between them, and a casting-house in common. The stock-house is placed near the furnaces, and sometimes one roof covers all. The engines, boilers, and hot-blast ovens are grouped closely about the furnace. Where calcining kilns are used, they are usually placed between the ore-bins and the elevators.

The general design should be such as to secure the least possible expenditure of labor in carrying the materials through the stock-house, kilns, and furnace, the least possible loss of air and gas by leakage, and the least waste of heat.

If the material supplied to the furnace can be brought by rail above the bins, and dropped into them directly, or into the calcining kilns, some expense for hoisting is usually avoided. The furnace-plant is to be located at a point from which the aggregate cost of transportation of materials to, and of product from, it shall be a minimum.

The distance from which it will be most economical to transport fuel, ore, and flux, and the manufactured products, will be nearly inversely as the quantities of each demanded or produced.

The cost of land and of construction will modify the problem in an important degree in many instances.

Water transportation is much less expensive than trans-

portation on land, and is to be preferred where a choice is offered. Cost of transportation is usually taken at twenty cents per ton per mile by wagon on the highway, one to two cents by rail, and one cent or less by water. These quantities vary greatly with difference in character of route, distance traversed, and rate of speed.

Where furnaces are situated near the mines, tramways of wood, or fitted with iron rails, weighing often as little as twenty-four pounds per yard (11.9 kilogrammes per metre), are used, the wagons being comparatively small, and drawn by horses.

In some instances, a low grade throughout permits the transportation of material by the action of gravity alone, the descending loaded cars or wagons raising the unloaded train to the starting point.

The connection of loaded to unloaded wagons is made by wire or steel rope, such as is used on elevators, passing over a pulley at the head of the incline, and having a diameter of from 1,000 to 2,500 times that of the wire of which the rope is made. The tenacity of such ropes may be taken at 60,000 pounds per square inch if of iron, and 80,000 (4,200 and 5,600 kilogs. per square centimetre) respectively, when of steel.

102. The System of Book-keeping adopted at blast-furnaces is extremely simple, and enables the cost of iron and profits to be determined readily. Few personal accounts are kept. The iron made is charged with cost of materials and of labor, office expenses and repairs, and the interest account, and is credited with receipts on sales. Thus accounts are opened with each of these items, and the pig-metal balance-sheet gives the cost and profits of the business.

The cost of making iron is always estimated whenever the project of building a blast furnace is entered upon. It must sometimes be entirely a matter of estimate, but, usually, experience at furnaces in the neighborhood of the proposed location, or in other districts, similar in character of material, and in their topography and relations to the market, enables a tolerably correct determination of cost and profit to be made.

The following is an estimate of cost of iron in a good locality, at which magnetic and hematite ores are both obtainable, and transportation comparatively inexpensive:

Ore, magnetic.. 1.5 tons @ \$4.00.....	\$6.00
Ore, hematite .. 0.5 tons @ 4.00.....	2.00
Coal	1.6 tons @ 4.00..... 6.40
Limestone	0.7 tons @ 1.50..... 1.05
Labor	2.50
Interest on \$500,000 @ 7 per cent. per ton of iron.....	1.00
Repairs and losses @ 10 per cent. per ton of iron.....	1.43
	<u>20.38</u>
Transportation to market of one ton of iron.....	1.00
	<u>\$21.38</u>

The following is an estimate which has been made for iron made with charcoal, in Alabama:

100 bushels of charcoal, @ 9½c.....	\$9.50
Ore	1.50
Limestone, ¼ ton50
Labor	2.50
Transportation to market, one ton pig-iron.....	6.00
	<u>\$20.00</u>

The statistics of blast-furnace work in Pennsylvania furnaces, during the twenty years succeeding 1855, as given by Church, present the following figures:

	MINIMUM.			COST PER TON OF PIG-IRON PRODUCED.				
	COST PER TON.			Coal.	Ore.	Flux.	Labor and Repairs.	Total.
1862.	2.37	2.59	0.34	4.79	4.79	0.47	2.45	13.05
				MAXIMUM.				
1864.	7.03	4.79	0.73	16.51	11.60	1.16	6.80	36.07
	AVERAGE FOR TWENTY YEARS.							
1855-1875.	3.61	4.15	0.60	7.74	8.45	0.88	4.72	22.94

These furnaces were large; the makers mined their own

ores, which were low grade, smelted with anthracite coal with hot-blast, 900° Fahr. (482° Cent.), under high pressure. The fuel ranged from 2½ tons or kilogrammes per ton or kilogramme of pig, to less than 2 tons or kilogrammes.

The raw materials used in iron making owe their value to the labor expended in their procurement. The cost of the metal consists, therefore, principally of wages; and, by reference to the above figures, it will be seen that the production of a ton of pig iron costs ten or twelve days of labor.

The average costs are usual figures, but, in times of depression, they may fall, as seen, nearly one half. For active periods the cost is usually from \$10 to \$15, and the market price \$15 to \$25, according to quality, \$20 representing average price nearly. Gray forge-pig has sold as low as \$10, and No. 1 Foundry as high as \$30, for special brands. The market reports of the trade journals always furnish current prices, and should always be consulted in making estimates.

103. The Location of the Blast Furnace is originally determined by the relative positions, topographical and political, of the ores, the fuel, and the fluxes used, and of the markets. Where the materials used are found in contiguous localities, as often happens, the furnace is usually located at a point as near as possible to that district. Where the materials are necessarily transported considerable distances, the cost may be reduced by location near the ore bed.

The materials used are, in order of quantity: ore, fuel, flux. Other things being equal, that furnace will be most economically located which is placed near the mines. In the cost of transportation is included, as a very important item, the expense of handling. The material should be brought to the furnace without change from one car to another. The transfer from one wagon, car or boat to another is more costly than miles of transportation.

Where the ores and fuel are widely separated, location is often determined by the facilities for marketing the iron, and the furnace is so placed that the total of all the costs of transportation and of working shall be a minimum.

If the quantities transported are O' , O'' , O''' , respectively,

and the cost of carriage is c dollars per ton, the distance for each being S' , S'' , S''' , the total cost,

$$K = cO'S' + cO''S'' + cO'''S'''$$

should, other things being equal, be made a minimum.

The total cost in all cases, of all materials, and of all running expenses reduced to amount expended per ton of iron made, is to be made a minimum.

In these costs is to be reckoned insurance, and under this head is to be included all risks of property due to local, to financial, to social, or to political causes. The latter may even prove controlling conditions in some cases.

The precise location of the furnace should not be determined upon until after very careful study of the various proposed sites, and after a consultation with all holders of capital affected by it directly and indirectly, as far as possible.

The cost of the structures is determined by local conditions largely, such as the availability of materials for brick-making, of stone quarries, of the manufactories of machinery, cost of skilled and unskilled labor, as well as the design and dimensions of the establishment.

An estimate for a furnace of 25 feet (7.6 metres) bosh and 85 feet (25.84 metres) high, was made for the Author in course of business, as follows :

COST OF MATERIALS.

Foundations.....	\$5,300
Fire-brick, plain.....	37,500
Red brick, plain.....	24,800
Cast iron.....	25,000
Engines, 84 inches (213.36 centimetres) diameter of air cylinder, 7 feet (2.13 metres) stroke.....	13,000
Boilers, 6, 36 inches (91.44 centimetres) diameter, 40 feet (12.2 metres) long.....	6,500
Pumps.....	2,500
Hoist.....	3,500
Sheet-iron work.....	4,000
Valves, pipes, etc.....	5,500
Sundry expenses.....	1,500
Total.....	<u>\$145,600</u>

A furnace 14 feet (4.266 metres) in diameter of bosh, 60 feet high (18.28 metres), with blowing engine having a steam cylinder 33 inches (83.82 centimetres) and a blowing cylinder 72 inches (182.88 centimetres) in diameter, and 6 feet (1.83 metres) stroke of piston, supplied with steam by 4 cylindrical boilers 40 inches (101.6 centimetres) in diameter, and 36 feet (11.54 metres) long each, and fitted with hot-blast stoves, and a stock-house holding four months' supply of coal, cost \$150,000 in times of rather high prices.

104. Determining the Value of a Furnace in actual operation, the engineer is required to inspect the furnace and its accessories, and its location, and learn the methods of working and management, means of transportation, cost of labor and materials, and value of the surrounding property. He must be able to report on the following points:

Ore, character, composition, cost, behavior in the furnace.
The same as to fuel and flux.

Method of weathering ore, method of roasting, cost.

Ore mixture, proportions, method of mixing, cost.

Hoists: kind, capacity and efficiency; size of barrows.

Furnaces: number and dimensions, age, time since blowing in, temperature, volume, and pressure of blast, and details of construction and management.

Blowing engines; number, size and capacity, design, situation, character of accessories.

Method of charging, size of charge and its proportions, number of charges passing through furnace in 24 hours, method of keeping account of charges.

Character of product, applications, extent of production; consumption of ore, fuel, and flux per ton produced; cost.

Character of slags, methods of disposal.

Composition, temperature, quality, color, and utilization of the furnace gases.

Peculiarities of location, arrangement, design and construction, of management, of ore, fuel, flux or product, and of deposits in the gas flues.

All of the above points must be carefully considered in determining the value of any furnaces.

The capitalist will further wish to know :

The names and character of the managers, and of those holding the stock.

The amount of capital stock, the amount paid up in cash, and the amount paid in other ways, and how paid.

The character and market cash value of assets and working capital.

The extent and character of all liabilities in full detail.

Amount of orders, prices and costs ; rate of growth.

In some cases it will be necessary to ascertain whether the stock has been or is to be "watered"; whether the product or the methods of working are new ; and other special points that may distinguish an individual case.

105. The Management of the Blast Furnace, in matters of detail, is determined by the size and proportion of the furnace, the nature of the materials charged, and the character of product desired, and is modified by all circumstances which affect the value of the product and the cost of its production. As in all other commercial operations, the enterprise is so managed, if possible, as to secure the maximum profit to the proprietors continuously for the longest possible period. Managers frequently pursue a tentative method in proportioning charges, fixing the temperature of blast, and in other matters of detail ; and an experienced and skillful manager can usually adjust the proportions of the charge very successfully after an examination of the available materials, and can keep the furnace running steadily, and secure a uniform yield and quality of product without a definite knowledge of the chemical constitution of the materials. A knowledge of the chemistry of the process of reduction and of the theory of the blast furnace, however, is usually considered important as a part of the preparation of the furnace manager as well as of that of the metallurgical engineer.

In the management of the furnace, it is desirable to obtain :

Iron of dark foundry grades, and of the greatest obtainable purity ;

Slags free from iron, but containing all foreign matters

which enter the charge, and sufficiently fusible to flow freely at the lowest temperature existing within the furnace ;

The least expenditure of fuel, consistent with the production of the best iron ;

Uninterrupted and uniform operation of all machinery and processes.

The darker grades of iron are of much greater value than the light gray and white irons, which latter are only available for making wrought iron, or, to a slight extent, for mixing with the very darkest grades. Good white, gray, dark Bessemer pig, and the finest of the dark gray, strong and tough cast irons, used for making car-wheels, hold, in the market, the relative values, 60, 75, 90, and 100, nearly.

The existence of very small proportions of sulphur and phosphorus reduces the value of this metal often 30 per cent.

The proportions giving a good slag have already been given as determined by Percy, and as adopted in practice.

Any deviation from the formula raises the melting-point, and increases the liability of the furnace to injury by the formation of "bears," and by the interruption of its working by this solidification of the slag. The presence of magnesia in excess is more objectionable than that of lime, and the latter is usually present in some excess over Percy's proportion. The higher the temperature of furnace, the greater the latitude permitted.

Economy of fuel is obtained by careful and uniform mixture of charge, and great regularity of working. Dark irons cannot be produced with the same economy of fuel as lighter grades, and a high temperature of blast aids in economizing coal. Variations of temperature, and especially in humidity of the air, produce variations of working, which a skillful manager will seek to counteract by changes in his charge, and in temperature of blast. Furnaces producing gray iron in warm, dry weather, will be likely to yield a lighter grade in cold and wet seasons, unless the proportion of fuel is increased, and the temperature of blast can be raised.

The manager is guided, to a great degree, by the appearance of the slag, and by its physical characteristics. If too

thick, the proportion of charge must be changed to give greater fusibility to the slag, or the temperature of the furnace must be elevated by using a greater proportion of fuel, or a higher temperature of blast. If too thin, the furnace-manager pursues an opposite course. If the slag is blackish green, too much iron is present, and more flux must be used. A light yellowish green, or a pink shade, indicates the presence of manganese, and is a good indication. Light gray, and stony, or a foamy, vitreous white slag, indicate complete reduction, and usually appear with foundry and Bessemer grades of iron.

The yield of the furnace is dependent upon many conditions; as size of furnace, character of the charge, temperature of blast, volume, humidity, and pressure of air-supply, and in a less degree upon the details. The iron contained in the ore should all appear in the pig-metal.

A cold-blast charcoal furnace, 9 feet (2.7 metres) in diameter, has given an average yield of 12 tons (12,168 kilogrammes) per week when running on red-hematite ores.

A coke-furnace, 70 feet (21.3 metres) high, of 25 feet (7.6 metres) bosh, running on roasted argillaceous ores, with a blast at a temperature of 1,100° Fahr. (593° Cent.), produces 400 to 500 tons (406,400 to 508,000 kilogrammes) per week.

A furnace 16 feet (4.8 metres) diameter, 66 feet (20 metres) high, using mixed anthracite and coke in the proportion of 1 to 3 by weight, and running on hard hematite ores, the temperature of blast reaching 900° Fahr. (482° Cent.), yields 350 tons (355,600 kilogrammes) of iron per week.

A furnace 20 feet (6 metres) in diameter, using anthracite alone, has often produced 2,800 tons (2,844,800 kilogrammes) per week, and the largest and most hard-driven coke-furnaces double even this output.

Small furnaces, running on easily smelted ores, sometimes exhibit great economy and a large yield. The Urbana furnace (Austria) is reported to have made 140 tons (142,440 kilogrammes) per week, consuming but 1,600 pounds (726.4 kilogrammes) of charcoal per ton (1,016 kilogrammes) of iron made. The stack is 36 feet (10.9 metres) high, and of

1,200 cubic feet (31 cubic metres) capacity. The blast has a temperature of but 390° Fahr. (199° Cent.). The best yield of larger furnaces is seen in the diagrams, Figs. 8 and 10, Arts. 85 and 86.

106. Cast Iron is the name given to the product of the blast furnace. It consists of metallic iron chemically united with carbon in proportions varying from two to nearly six per cent., silicon to the amount of sometimes five per cent., and usually manganese, phosphorus, and sulphur, in smaller proportions. Foundry irons also contain carbon in two forms, chemically united, forming a carbide, and mechanically mingled with the metal in the form of graphite. Minute quantities of calcium and other substances are also found in it. Analyses will be given hereafter.

The cast iron, when removed from the casting house, is assorted and sent to market in several grades. The darkest kinds of metal, which contain most carbon, are called foundry-pig, and the lighter grades forge-pig. The classification is usually as No. 1 Foundry, No. 2 Foundry, No. 3, or Gray Forge Iron, Mottled Iron, and White Iron.

The darker grades are used for castings, and the lighter for the manufacture of wrought iron.

The characteristics of the several grades of iron are thus summarized:

Foundry Irons.—No. 1 (Dark Gray Iron): Fracture dark gray, with high metallic lustre. Crystals large, with lustre resembling surface of fresh-cut lead. Makes fine castings; fuses easily; flows freely, is soft and rather ductile.

No. 2 (Gray Iron): Fracture gray; lustre clearly metallic; crystals smaller than preceding; a freely melting, free flowing, and moderately strong iron.

No. 3 (Light Gray Iron): Fracture light gray; crystals small; lustre dull; crystals larger and brighter near centre; makes best material for large castings.

Forge Irons.—No. 4 (Bright Iron): Fracture light gray; crystals small; lustre slight; too infusible and pasty for foundry use; makes good mill iron.

No. 5 (Mottled Iron): Fracture dull, silvery white; line

of whiter iron around edge of fracture; speckled with gray within; hard, brittle, but sometimes a good forge iron.

No. 6 (White): Fracture silver white; often bright; granulated texture, with radiating lines of crystallization; extremely hard and brittle; useless except for low grade puddled iron.

The properties of cast iron will form the subject of a succeeding chapter.

107. The Bloomary, or Catalan Process.—The reduction of ores of iron is sometimes practiced by other methods than that already described. The most common is that known as the Bloomary, or the Catalan Forge Process. It is practiced in Spain, as indicated by its name, in Sweden and Germany, and perhaps other parts of Europe, and, in a rude way, in Asia and Africa, as already described in Art. 34, page 41.

The product is wrought iron or steel in masses called "blooms," which vary in size with the size of furnace, up to 300 or 350 lbs. (136 to 159 kilos) in weight.

The process can be made commercially successful in districts in which very rich ores and abundance of wood for charcoal can be obtained and at low prices.

The furnace usually consists of an open hearth of about 28 inches (70 centimetres) depth to rear wall, and 30 inches (76 centimetres) width, and with tuyeres inserted 2 feet (0.6 metres) below the level of the top of the mass of fuel.

The casing is of cast iron, double and supplied with water, to keep it from becoming overheated. Above the hearth a stack is built to carry away the products of combustion. The hearth is open at the front like an ordinary open fireplace. The blast is supplied under a pressure of from $1\frac{1}{2}$ to 2 pounds per square inch (0.11 to 0.14 kilogrammes per square centimetre), and heated to a temperature rarely if ever measured, but generally supposed to be 600° to 800° Fahr. (316° to 426° Cent.). The heating pipes are bent U tubes placed in the stack.

The tuyeres are either pointed horizontally or slightly inclined downward, and have a segmental opening for the better distribution of the blast.

In working ores by this process, the furnace is filled with

charcoal, the fire lighted, and the blast turned on. When the whole is well ignited, the ore, calcined and coarsely pulverized under stamps or breakers, is sprinkled with a shovel over the surface of the mass of fuel in small quantities, and at short intervals basketfuls of charcoal are added as the fire burns down. The ore is deoxidized by the carbon of the fuel as it works downward, and the metal finally aggregates in an unfused pasty mass of agglutinated grains at the bottom of the hearth, like a great sponge. The cinder fills its pores and surrounds it as a liquid bath, and is tapped off occasionally at the front.

A "loup" weighing about 300 pounds (136 kilogrammes) is formed in about three hours. This is lifted out from under the mass of fuel and is worked under a hammer of about 5,000 pounds (2,272 kilogrammes) weight into a billet or bloom, being reheated, when necessary, at the bloomary fire.

The men work in two "shifts" of twelve hours each, and each fire is expected to yield from one ton to 2,500 pounds (1,136 kilogrammes) per day. The amount of fuel used varies from 200 to 300 bushels (5,664 to 8,496 litres), 3,500 to 5,000 lbs., per ton ($1\frac{1}{2}$ to $2\frac{1}{2}$ kilogrammes per kilogramme), according to the skill of the iron-maker and the quality of ore and fuel. The total cost of the bloom is not far from that of puddling iron. One ton (1,016 kilogrammes) of finished metal requires from $1\frac{1}{2}$ to $1\frac{3}{4}$ tons (1,524 to 1,778 kilogrammes) of selected ore, which is equivalent to from $2\frac{1}{2}$ to 4 tons (2,540 to 4,064 kilogrammes) of ore as mined.

108. The American Bloomary Process, for making iron direct from the ore, is a modification of the old German process, although it is in many places incorrectly spoken of as the Catalan Process. Like the Catalan, it is adapted to rich ores of iron that are free from all impurities save gangue, which, before entering the furnace, must be removed as far as possible. Ores to be profitably worked by this process usually contain above 90 per cent. of magnetic oxide of iron. The ore is by this method roasted, crushed, and then subjected to this process. The furnace is composed of cast-iron plates 2 or 3 inches (5 to 7.5 centimetres) thick joined together, form-

ing an open box, which, at the base, is from 24 to 30 inches in its length (61 to 76 centimetres) at right angles to the tuyere, while the dimensions are 27 to 32 inches (68 to 81 cm.) laterally. In the rear, parallel to the tuyere, it is from 28 to 36 inches (71 to 91 cm.) deep. In front, however, it is from 15 to 19 inches (38 to 48 centimetres), to make room for the "fore plate." This rectangular space is known as the "fire box," and it is here that the reduction takes place. The air pressure is from $1\frac{1}{2}$ to 2 pounds per square inch (0.11 to 0.14 kilogramme per square centimetre). The stack, through which the products of combustion and gases pass, is of rectangular section and of sufficient size to receive the whole furnace under it. This stack is about 20 feet high (6.1 metres).

The higher the temperature of the blast the less fuel consumed. It ordinarily varies from 600° to 800° Fahr. (316° to 426° Cent.), but it has been found that by raising the temperature of the blast, the tendency for the impurities present to enter into the iron is increased.

One "D"-shaped tuyere is used, made of $\frac{1}{2}$ -inch (1.27 centimetres) wrought iron. The nozzle is about a foot (18 centimetres) long, and is inclined at an angle of about 15° . If this angle is too low, the capacity of the furnace is diminished by the coal forming a crust on the bottom; if it is too high the blast cuts through the loup. The ordinary cost of a furnace such as is described here is about \$600. The remainder of the process closely resembles the Catalan. The amount of fuel used is from 300 to 350 bushels (8,496 to 9,912 litres) of charcoal per ton of iron. A ton is said to have been produced with an expenditure of 240 bushels (6,796 litres). The production of a furnace of the size described averages 1 ton (1,016 kilogrammes) in 24 hours, or about 300 tons (304,800 kilogrammes) in a year.

109. The Siemens Process of reduction of ore, or "Direct Process," as this method is termed, is one which has attracted much attention, but one which is not yet generally introduced. In this process the ore and flux are fused together in the reducing flame of the regenerative furnace,

and the cinder is tapped off at intervals, leaving, finally, the molten iron on the hearth, to be drawn off into ingot moulds. The process occupies four or five hours, and the product consists of four or five tons of wrought iron or steel.

In the latest modification of this process Mr. Siemens avoids the serious difficulty attending the reduction of an ore on the hearth of the reverberatory furnace by effecting the change in a rotating cylinder similar to the rotating puddling furnace, to be hereafter described, and by adopting a peculiar composition for the lining.

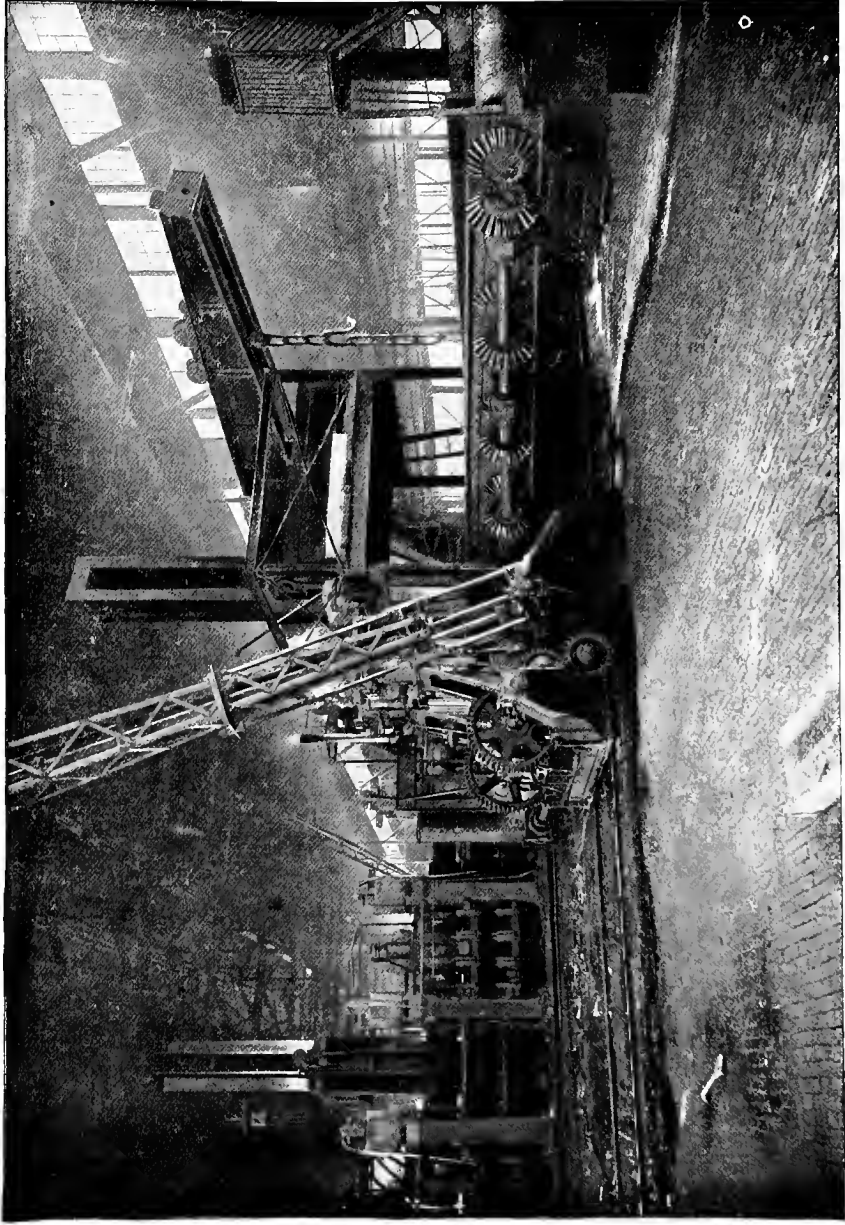

COPYRIGHTED BY CASSIEN'S MAGAZINE, NEW YORK.

CARNEGIE HEAVY MILL. (35-inch.)

CHAPTER VI.

THE MANUFACTURE OF WROUGHT OR MALLEABLE IRON.

110. Wrought Iron is distinguished from cast iron, chemically, by its comparative freedom from carbon, silicon, and other elements which enter into the composition of the product of the blast furnace to such an extent as to form an important part of the latter material, and by its greater strength, ductility, and homogeneousness. It has immensely greater value as a material of construction. Its peculiar properties will be considered at length in a succeeding chapter devoted to that subject.

It may be manufactured by the direct reduction of the ore, as in the bloomery, the Siemens and the other "direct" processes already described; but by far the greater part of the wrought iron which appears in the market is made from cast iron by the removal of carbon, silicon, and impurities by the process of refining and puddling, and is worked into marketable shape by rolling or by hammering.

Very large quantities of a metal which resembles wrought iron closely in chemical composition and in mechanical properties—and which is properly classed with malleable or wrought iron—is made by the pneumatic, or Bessemer process, and by the Siemens-Martin process, and sold in the market as "low steel," "Bessemer steel," or "Siemens-Martin steel," or, as lately proposed, under the name of "ingot iron."

These processes of manufacture will be described in a chapter on the manufacture of steel.

111. The Decarbonizing Process consists in the subjecting of molten cast iron to the oxidizing flame of a reverberatory furnace until the carbon has been burned out and the metal is sufficiently pure to become pasty, and to cohere in spongy masses at the maximum temperature of the furnace.

For these processes, the lighter grades of cast iron are selected as containing least carbon, and therefore demanding less labor, and as they are cheaper than the dark, foundry grades.

Cast irons containing sulphur and phosphorus are less valuable than irons free from these elements, as the former yield a malleable iron which is brittle and difficult to work and to weld at high temperatures, and the latter make the product brittle and non-ductile when cold. Manganese, from its chemical relations as an antidote to sulphur, is a desirable ingredient. All other foreign substances are undesirable. The carbon and silicon are removed during the process of conversion; the sulphur is partly driven off, as is manganese; the phosphorus is retained in the iron.

The earliest processes of making wrought iron were, as already stated, direct processes. The earliest process of reduction of cast iron, and that which was practiced at the time of the invention of puddling by Cort, is still practiced, and is known as the Refinery or Forge Process.

112. The Forge Process is, in method of working, similar to the bloomary process, and the forge fire is constructed very much as is the bloomary.

Instead, however, of reducing ore by expelling its oxygen in presence of an excess of carbon, the forge process burns out carbon from cast iron in presence of an excess of oxygen.

As practiced in the United States, where the process is adopted to a limited extent in making blooms and billets to be worked into boiler-plate, it consists in melting down pig-iron on a shallow hearth under a blast until about 250 pounds (113 kilogrammes) is collected under the tuyeres. The molten mass is stirred with an iron rabble and the blast kept on it until, the carbon having been burned out, the iron becomes pasty and adherent, and can be worked into a ball. The cinder which collects as the impurities are worked out, is now and then tapped off. When steel is made by this process the cinder is retained, and the ball is worked in a bath of the molten slag. When ready to "ball up," the temperature of the fire is raised, the metal worked over to free it from cin-

ders, and then balled up and removed from the fire to be worked into billets or blooms.

One fire worked twelve or thirteen hours per day by a single shift of hands, produces five or six "loups" weighing about 200 pounds (91 kilogrammes) each. If the iron has been refined previously, as described in the succeeding article, the production is sometimes doubled. The consumption of pig-iron and of charcoal in this process is about 1,800 and 2,400 pounds (817 and 1,090 kilos) respectively. The greater number of forges of this kind in the United States are in Pennsylvania. The process is adopted, to some extent, in Sweden, Germany, and other parts of Europe. In a large number of cases, establishments started as bloomeries have been changed into forges for the reduction of malleable from cast iron.

113. Refineries are forges in which the process just described is interrupted when but a portion of the carbon and other oxidizable substances are removed from the cast iron.

The refinery is usually larger than the forge above described, measuring $3\frac{1}{2}$ feet (1.06 metres) wide to the back, $5\frac{1}{2}$ feet (1.67 metres) long, and its hearth has a depth of a foot or eighteen inches (0.304 or 0.456 metre). From one to two tons (1,016 to 2,032 kilogrammes) of pig-iron can be melted down and retained in it. The large size of the hearth compels the use of four or more tuyeres.

The metal is sometimes run into the refinery from the blast furnace, and sometimes charged in pigs and melted in the forge. The metal, subjected to the action of the blast, "boils," and gradually loses carbon, and is finally tapped off on the casting-floor, or into moulds, in which it assumes the form of flat plates about ten feet (3.04 metres) long, three feet (.91 metre) wide, and two inches (5.08 centimetres) thick. These plates are broken up and used in the forge or in the puddling furnace.

Each charge requires about two hours for complete refining.

The loss of iron is from 8 to 20 per cent., according to the skill of the workmen. The usual loss is about ten per cent.

The expenditure of fuel is about one part to five parts of iron in good work. This "finery furnace" is also called a "running-out fire." One fire will refine from 10 to 20 tons (10,160 to 20,320 kilogrammes) of metal per day. Either coke or charcoal may be used as fuel.

The "fine metal" is a white cast iron, from which nearly all silicon, a large part of its carbon, and much of its manganese and sulphur, as well as some phosphorus, have been removed. The slag, which contains those substances which are not volatilized, is a silicate of iron containing about 53½ per cent. iron oxide, and 14½ per cent. silicon, and 32 per cent. oxygen, the formation of the silicate involving a serious loss of iron.

114. Puddling and Boiling are modifications of the same process, and in both the refining, as already described, is carried on until the character of the metal is entirely changed, and the product is obtained which is known as malleable or wrought iron.

In the manufacture of malleable iron by these processes, the metal is melted as in refining, but the fusion takes place on the hearth of a reverberatory furnace in which the metal only comes in contact with the gaseous products of combustion, and is thus less exposed to contamination by the deleterious elements found in fuel, and the necessity of a powerful blast to secure a supply of air is avoided. Draught is secured by a moderately tall chimney, or by a fan-blower, and controlled in the former case by a damper on the chimney-top.

While the metal lies in the molten state on the hearth the puddler stirs it with an iron rabble, and thus brings every portion in contact with the decarbonizing flame. This oxidizing action of the air is seconded by the presence of fluxes rich in oxygen, such as magnetic hematite ores, or scales from the blacksmith's forge. Slag and cinder, rich in iron oxide, are sometimes used where they can be obtained free from sulphur and phosphorus, or where the puddled iron is of a cheap grade.

In "dry-puddling" the puddler relies upon the action of

the air principally; in "wet-puddling" the work is largely done by the oxides used in "fettling." The first method is usually called, simply, puddling, the latter is often known as "boiling," or as "pig boiling."

The form of reverberatory furnace ordinarily used in the puddling process, is illustrated by Fig. 14.

The hearth, *A*, is made, usually, of plates of cast iron, carried on brick walls or on short iron pillars, *bb*. It is usually about five or six feet (1.5 to 1.8 metres) in length, and four feet in width, opposite the charging door. This hearth is covered thoroughly with slag, or with a "fettling" of iron oxide, which is melted down upon it to protect the plates from the solvent and corroding action of the charge.

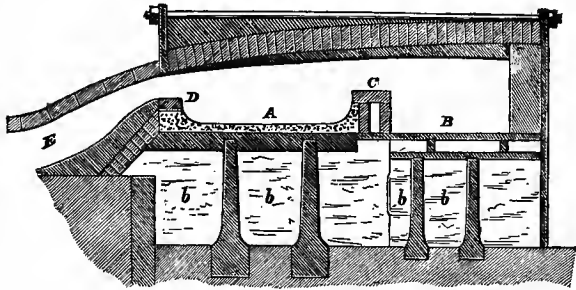

FIG. 14.—PUDDLING FURNACE—VERTICAL SECTION.

The fire is built, usually, of bituminous coal, in the fireplace, *B*. The grates are generally single square rods of iron separately detachable. They can be removed singly to clean any part of the fire, or replaced when any one of them is burned out or droops under excessive heat.

The area of grate is usually six square feet (0.56 square metre), and sometimes ten feet (0.93 square metre), or more, its precise dimensions being determined by the character of the metal used, of draught, and of fuel. Between the grate and the hearth is a fire-brick wall, or "bridge-wall," *C*, extending from side to side, rising sufficiently high to prevent any portion of the fuel passing over on the hearth or any molten iron falling over upon the fuel.

Resting upon and extending around the sides of the hearth is a box, or a double wall of cast iron, eight or ten inches (20 to 25 centimetres) high, through which hollow box

water circulates, preventing its fusion. The iron bottom is also sometimes double and similarly kept cool. Air is sometimes substituted for water as a cooling medium. The sides, like the bottom, are carefully protected by a coating of slag and ore laid on under so high a temperature that it may be readily moulded.

At the end nearest the chimney, the hearth terminates at a second bridge or "altar," *D*, which prevents the overflow of the molten metal at that end. Beyond this bridge-wall, the furnace flue inclines downward and terminates at the chimney flue, *E*, the cross-section of which is usually given 20 per cent. of the area of the fire-grate. At the foot of the incline is an opening out of which the molten slag passes after leaving the hearth and overflowing at the altar. On the side of the furnace, opposite the middle of the hearth, is the working door. It is about 20 inches (51 centimetres) square, and is closed by a slide lined with fire-brick, which is arranged to rise and fall vertically, and is counterbalanced. A small opening at the bottom of the door, large enough to admit the puddler's rabble, permits the workman to stir the charge without serious discomfort, and without admitting cold air to chill the furnace and check the draught.

The roof of the furnace is an arch of fire-brick, about two feet (0.6 metre) high at the fire-place, and sloping gradually, until, at the chimney, it is less than a foot above the bottom of the flue.

Outside the furnace, at the opening at the foot of the chimney—the floss-hole—a fire is maintained to keep the escaping cinder fluid until it has fairly left the furnace. In some furnaces a charging-door is placed near the altar, through which the pig-metal is placed "on the bank" to be melted down.

The original process, as practiced by Cort, the inventor, was that of dry puddling. He made up his furnace-bottom with quartz sand, and used iron containing little carbon, removing that remaining by the oxidizing action of the flame alone. Refined iron, and the white and mottled grades, are generally used in this process, as they promptly become

decarbonized, assume a pasty condition, and can then be balled up. The cinder-bath is produced by the union of the silica present with iron-oxide. The loss of metal is variable, but may be taken at an average of nearly ten per cent. In the time of Cort a furnace could be made to produce but about ten tons (10,160 kilogrammes) per week. Subsequent improvements, including the ventilated bottom, doubled this quantity.

115. *In the Boiling Process*, or that of "wet-puddling," the furnace is made rather deeper than for puddling. Rich cinder is used for fettling, and is charged into the furnace, and mingles with the pig-iron, its oxygen taking up the carbon of the iron, and thus hastening the process of decarbonization, the melting and molten iron lying in a bath of fluid cinder.

Unrefined iron can be worked by this method, and instead of losing iron, if the process is well managed, some gain of weight is made by reducing the oxide charged, and the fettling of the furnace. The first process, often called simply puddling, is in use in making low grades of iron from white pig-metal. In the boiling process, No. 3 pig-metal is generally used, but sometimes gray pig, and in other cases, refined iron.

The charge of the puddling furnace is about five hundred pounds (227 kilogrammes) of pig-metal, which is laid carefully on the bed of the furnace, or broken up and piled on the bank and around the sides. In the boiling process, the necessary amount, 100 pounds (45 kilogrammes), more or less, of cinder, or ore, and hammer-scale is added.

The door is then closed, and the damper opened wide, and the charge is melted down, the puddler moving the pieces among each other to secure a regular and not too rapid fusion, and to give the flame free access to the metal. Fusion commences in fifteen or twenty minutes, and in a half hour the charge lies in a molten pool on the hearth, and assumes a pasty condition. The puddler stirs the fluid mass with his rabble, checking the draught to give more time for completing the chemical reactions, and even chills the metal by throwing water upon it. The heat is again increased, and

the intermingling of iron and cinder produces a rapid union of oxygen and carbon, and this evolution of carbonic acid and oxide produces rapid "boiling" and frothing. The lining of the furnace yields oxygen also by the reduction of the oxide of which it is composed.

The boiling soon ceases, and small masses of reduced iron appear here and there. In an hour or more from the commencement, the whole mass is an aggregation of pasty grains, and the puddler, raising the temperature of the furnace to its maximum, works the iron which has been "brought to nature" into a half dozen spongy masses of convenient size; weighing about sixty to eighty pounds (27 to 36 kilogrammes) or more each, meantime working his fire until a smoky flame appears, and thus he secures the now nearly pure iron from oxidation. The balls thus made are heated up to welding temperature, well worked and compacted, and finally removed from the furnace.

Using gray iron, six heats are made in twelve hours; with white iron seven can be made. The loss of weight of pig amounts to under ten per cent., and the fuel used amounts to about one ton or kilogramme of coal per ton or kilogramme of iron made by the process of boiling. With refined iron, the consumption of metal is about 2,300 pounds per ton (1,044 kilogrammes per 1,016 kilogrammes), and of fuel about $\frac{3}{4}$ ton (762 kilogrammes). Two men are employed at each furnace, the puddler requiring an assistant to manage the fire, and to aid in lifting the iron into and out of the furnace. The best work is done when the iron is puddled in small quantities.

116. The Principles and Theory of Puddling are evidently very simple. Urbin divides the process into five periods: that of fusion; that of purification; that of refining to produce grain; that of carbonizing the grain, and that of final refining by the flame.

While melting, a part of the metal is oxidized, and the resulting oxide unites with the cinder present in decarbonizing the remainder of the charge. The decarbonization produces nearly pure iron, and after refining the grain the proc-

ess of recarbonizing may go so far as to produce a puddled steel. The extent of this recarbonizing, and of the final refining under the flame, determine whether the product shall be a kind of steel or a malleable iron.

The office of the oxides used, as slag, cinder, scale, or iron ore, is to oxidize the carbon and impurities present in the pig-metal. The bath formed of these substances surrounds and permeates the grains of reduced iron toward the end of the process, and the richer in iron, the more completely does it answer the purpose of giving a fine grain. It must, however, contain a sufficiently moderate quantity of metal to permit the formation of protoxides. If sufficiently basic, yet rich in iron, it will cause a moderately slow decarbonization, will be fluid enough to permit very free circulation of the grains of metal when formed, and will be readily separated from the sponge when the puddle balls are made up.

The best cinder will be fluid and white in color. It chills quickly in the air, and has a peculiar greasy appearance. If too acid it will usually have a red tinge, will be quite fluid, and will solidify quite slowly outside the furnace.

In selecting and mixing the metal to be charged, the design should be to secure a uniform character of product and good quality. The best pig metal will make the best wrought-iron. Irons of very different quality cannot usually be worked well together.

The cinder charged is usually obtained from under the hammer as scale, or from the rolls; it is liable to produce an injurious effect by returning to the metal objectionable ingredients, and by making the iron work dry. Wrought scrap is often used in making up the charge. It should always be added in small pieces, such as can be easily handled by the puddler with his rabble.

By proper management of the fire, the puddler obtains either an oxidizing or a carbonizing flame. The character of the flame is not only important as modifying the action of the gaseous current on the iron directly, but, by reaction, upon the slag.

In puddling pig metal containing sulphur or copper, lead

or zinc, more time is required than with pig free from these impurities. Some waste is likely to arise from this increased time, which permits greater oxidation. The slag contains the wasted iron as ferrous and manganese silicates and magnetic oxide, and is charged with the sulphur and phosphorus removed in the states of sulphide and phosphate, and the loss of iron is supposed to be always increased with increase in the proportion of these separate impurities. The presence of manganese has, nevertheless, been shown by Caron and others to be useful by its counteraction of deleterious effects of sulphur, as in the pneumatic process. As the silicate of iron, which forms the body of the slag, contains between three and four times as much iron as silicon, the existence of an excess of silicon in the pig metal involves serious loss of metal in puddling. The removal of 3 per cent. silicon would cause a loss of about 10 per cent. iron. The time required for removal of carbon is given as follows :

TABLE XXXIV.

PROGRESS OF DECARBONIZATION.

	Time.	Carbon.	Silicon.
Pig Metal Charged.....	12 M.	2.275	2.720
Sample No. 1.....	12.40 P.M.	2.726	0.915
Sample No. 2.....	1.00 P.M.	2.905	0.197
Sample No. 4.....	1.20 P.M.	2.305	0.182
Sample No. 6.....	1.40 P.M.	1.206	0.163
Sample No. 8.....	1.50 P.M.	0.772	0.168
Puddled Bar, 9.....	0.296	0.120
Wire-rod, 10.....	0.111	0.088

It is seen that the silicon is nearly all removed before the carbon is attacked and during the first period of low temperature, and that the removal of the carbon occurs rapidly during the second half of the process. Siemens has shown that no silicon is taken up by fluid cast metal in contact with silica or silicates, and has stated that the removal of the silicon and carbon is due to the action of the oxides contained in the cinder alone, which oxides are decomposed, yielding the oxygen to the carbon, and adding to the bath the iron thus reduced. This indicates the wastefulness of the dry process, as above

shown, and the comparative economy of wet-puddling or boiling. The loss of metal in the first, or the amount of oxide needed in the second, is thus calculated, the formula for the oxide being Fe_3O_4 , and the atomic weight, 232. The atomic weight of the iron is $3 \times 56 = 168$, and hence there is required, in weight of oxide, $\frac{232}{168}W = 1.4W$, where W represents the weight of iron to be reduced, and an equal weight is needed to form the bath of cinder. It is vastly cheaper to supply this as oxide than to oxidize the metal on the hearth.

The quantity of heat carried away by the water circulating through the water bottom and the sides of the puddling furnace has been found, by experiment, to amount, in some cases, to but about 60,000 British thermal units (15,000 calories) per hour.

The gases discharged from the common form of puddling furnace are at so high a temperature that a vast quantity of heat is necessarily lost. The heat needed for melting one ton of metal is less than that obtained from 150 pounds (68 kilogrammes) of good coal. As already shown, the immense loss here experienced can be reduced by increase of temperature of fire, or by utilizing waste heat, as in the Siemens furnace, or in heating steam boilers.

117. New Methods of Puddling, and especially methods of *mechanical puddling*, which are intended to supersede the usual method of working the bath with the rabble in the hand of the puddler, are little practiced.

Many devices, in which the puddler's rabble is worked by machinery, have been invented, but, although adopted to some extent in Europe, none have come into extensive use. It has usually been found necessary to employ the same number of workmen as before, and the expense of the building and maintenance of the machinery is considerable. The quality of the product is rarely as good as when the puddling is done by hand.

Siemens has puddled iron successfully in the reverberatory furnace under the neutral flame of the regenerative furnace, the requisite oxygen coming entirely from the cinder and fettling. He has turned out 18 heats in 24 hours, effecting

reduction entirely by the cinder, his yield exceeding the charge in quality and weight.

In the Henderson Process, which is one of the most promising, the process of manipulation is nearly the same as in ordinary boiling, but the inventor introduces a peculiar cinder, by the addition to the bath of a flux containing fluor spar and titaniferous iron ore. Impurities pass off as volatile fluorides. Pig-iron, containing nearly 1.5 per cent. of phosphorus, has been made into wrought iron, proven, by Kirkaldy, to be of excellent quality. Iron made from pig containing 0.91 per cent. of phosphorus, was found to contain, according to analysis by Williams, but 0.09 in the finished metal. In other instances the proportion was reduced from 1.35 to 0.04 per cent. Pig-iron, containing considerable sulphur, was made into puddled iron containing but a trace.

In the Ellershausen Process of refining metal to be used in the manufacture of puddled iron, the stream of molten iron issuing from the blast furnace is led along troughs lined with oxides, and, by the same reactions which occur in refining, the carbon and silicon are partially removed.

The most generally introduced, and, as thought by many engineers, the most promising improvement, is the introduction of rotating or revolving furnaces, such as have been devised by Danks, Sellers, and Siemens.

118. Rotating Puddling Machines are a form of puddling furnace in which the metal is agitated by the revolution of the furnace instead of by the puddler's rabble. The general plan is very old; but the first invention of this class to obtain an extended trial was that of Samuel Danks, of Pittsburgh, Pennsylvania; it has been introduced, with varying success, both in the United States and Europe. This apparatus (Fig. 15) consists of a cylindrical vessel, *A*, 4 feet (1.2 metres) or more in its internal diameter, and of nearly the same length, mounted on rollers in such a manner that it can be rotated by means of gearing. It is open at each end and receives the flame from a furnace, *B*, at one end, and delivers the gases to a chimney flue, *C*, at the other end.

A fan-blast supplies oxygen above as well as below the bed

of the fuel. The part of the chimney flue next the barrel of the furnace is detachable and can be swung aside to admit the charge of metal, or to permit the introduction of a rabble, or of the tongs used in removing the puddle-ball. A crane, *D*, takes its weight.

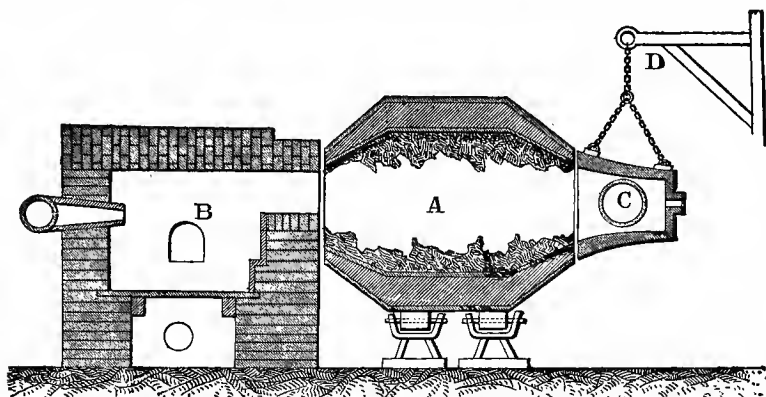

FIG. 15.—DANKS' FURNACE.

The barrel of the furnace is of iron and constructed of staves hooped with strong wrought-iron bands. It is lined first with a paste of pulverized iron ore and clean lime, and, after this has set, with a fettling of iron ore fused in place while the furnace is slowly revolving. This lining weighs from 2 to 3 tons (2,032 to 3,048 kilogrammes) in furnaces capable of taking 600 to 750 lbs. (272 to 341 kilos) at a charge.

The furnace is either charged with solid pig-metal, or with molten cast iron from a cupola. The barrel is revolved, when the charge is perfectly fluid, once or twice a minute. When the iron begins to thicken, toward the end of the process, the motion of the furnace is stopped, and the cinder is tapped off at so high a temperature, that it is very fluid. The furnace is then started, and driven at a speed of six to seven revolutions per minute, until the violently agitated iron becomes pasty. Speed is again reduced to two or three revolutions per minute, and the sponge is thus worked

into a ball, which is removed by means of a fork carried in slings by a crane. Refined metal is puddled in 35 minutes after melting. The puddle-ball sometimes weighs 1,000 pounds (454 kilogrammes) or more, and the charge of pig-metal as much as 2,000 (909 kilogrammes). The machinery for working it into bar is necessarily specially designed to handle these great masses. Spencer and Crompton, in Great Britain, and other inventors, have introduced modifications of this furnace. Siemens has used a furnace of this class in making iron direct from the ore.

The Rotating Puddling Machine of Messrs. Sellers & Co. (Fig. 16), is an egg-shaped rotating vessel, having an opening

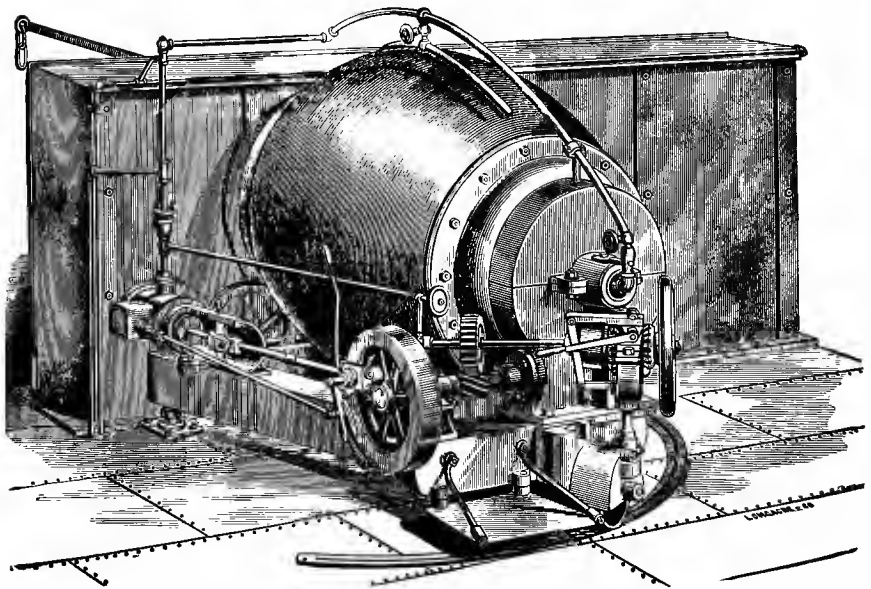

FIG. 16.—SELLERS' PUDDLER.

only at one end, through which the flame from the furnace enters at its upper side, and issues below, after eddying over through the revolving chamber, which is mounted on a set of friction wheels at each end. The whole system, including

the steam-engine by which it is rotated, and by means of which also the vessel is caused to swing horizontally through an arc of 90° when it is to be charged, or when iron is to be removed, is mounted upon a platform pivoted at the end nearest the flue, and sustained by wheels traversing a set of tramways on the floor.

Friction clutches throw the engine into gear when it is designed either to revolve the "bowl," as the vessel is sometimes called, or to turn the vessel into position for charging or working. The gas used for heating this furnace is supplied by gas-producers, and rejected heat is economized by regenerators. Heat issuing through the wall is intercepted by a water back.

The iron to be puddled is usually charged molten, from a cupola. The process of puddling is similar to that practiced with the Danks furnace, but the higher temperature of the furnace gases, and their greater uniformity of character and purity, are claimed advantages, as are those due to the peculiarities of design. The ability—secured by the use of these furnaces—to handle large masses with economy of labor and convenience, is the most marked of their advantages.

In the above-described furnace, the chamber revolves in the vertical plane. In other and later forms, as Ehrenwerth's and Pernot's furnaces, this revolution takes place in the horizontal plane.

Mansley's (British) and Ehrenwerth's (Bohemian) machines are reverberatory furnaces, in which the hearth is circular in form, detached from the body of the structure, and mounted upon a vertical shaft, by means of which it can be set in motion rotating in the horizontal plane. The joint between the hearth and the adjacent parts of the furnace is closed by a water-seal, the edge of the hearth carrying a flange, which dips into a circular water-trough attached to the furnace. In this furnace the molten metal is stirred by broad-bladed rabblers, held by the workman or by mechanism, as may be thought best. The charge weighs from three-quarters of a ton to one ton (762 to 1,016 kilo-

grammes). The power required to rotate the hearth 20 to 25 times per minute is given as $\frac{1}{2}$ to $\frac{3}{4}$ horse-power.

A saving of fuel, time, and capital, the health of the puddler, and a peculiar uniformity of product, are advantages claimed for these furnaces.

Pernot's Puddling Furnace is quite similar in form to the preceding, but the plane of revolution of the "pot," or basin-

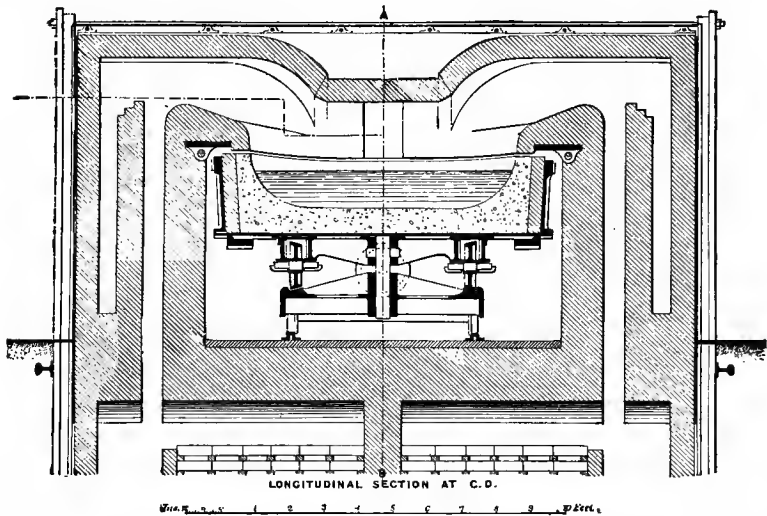

FIG. 17.—PERNOT'S FURNACE.

shaped hearth, is inclined at an angle of 10° or 15° from the horizontal, the lower side being next the charging door. The pot is kept cool by the circulation of water through its double sides and bottom. A fan-blast is used. The inclination of the pot causes a flow and intermixture of the molten metal, like that in the Danks type of furnace.

The retention of the ordinary form of reverberatory furnace permits the use of a charging door, as in the ordinary furnace, and this combination of the two details affords exceptional opportunity for working the charge, and for dividing it into any convenient number of puddle-balls. One

of the most important of the advantages of this type is, that the pot may be mounted on a movable carriage, and then arranged to be wheeled bodily out of the furnace and back again, when the lining requires repairs, thus saving the time usually lost in waiting for the furnace to cool.

A furnace having a hearth 7 feet 10½ inches (2.4 metres) in diameter, takes a charge of one ton (1,016 kilogrammes).

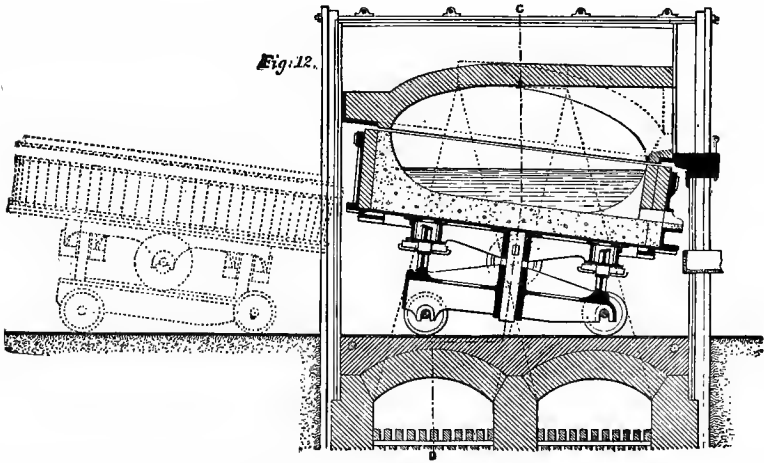

FIG. 18.—PERNOT'S FURNACE.

Four, and sometimes five charges of pig-iron can be worked in twelve hours, and each charge is worked into from fourteen to twenty balls. One furnace puddles 8 or 9 tons (8,128 or 9,144 kilogrammes) from refined iron in twelve hours, losing one-third as much iron as is lost with the ordinary furnace, and with a saving of 20 to 25 per cent. of fuel. With common pig-metal the saving is greater, sometimes reaching 33 per cent. This furnace is used in making steel.

The following statement gives the cost of puddling, as reported by the Home Iron Works, 1874 (to-day iron can be made at two thirds this cost):

COST OF PUDDLING (DURFEE).

	Ordinary Process.		Rotating Furnace.	
Pig-metal	1.654 tons,	\$27.73	1.061 tons,	\$25.68
Fuel coal.....	1.002 tons,	3.78	0.703 ton,	2.46
Wrought iron scrap.....	0.019 ton,	0.42	0.057 ton,	1.00
Hammer slag.....	0.025 ton,	0.10	0.078 ton,	0.32
Labor.....		3.35		3.35
Repairs.....		1.18		1.18
Miscellaneous.....		1.52		1.63
		<u>\$38.08</u>		<u>\$35.62</u>
Deduct scrap bar.....				.65
				<u>\$34.97</u>

119. The Puddle-Ball, as withdrawn from the furnace, is a spongy mass of iron, of which the pores and smaller cavities are filled with liquid cinder. The chemical composition of the mass is therefore neither uniform nor otherwise satisfactory. The ball contains iron, generally almost completely decarbonized, and mingled with an impure silicate of iron, into which has passed nearly all the silicon originally contained in the pig metal, and some of the sulphur, with a small part of the phosphorus, and the greater part of all other impurities. The carbon originally present has been oxidized, and has passed off by the chimney. In making "puddled steel," just as much carbon is left in the sponge as can be retained without depriving the metal of its power of welding. This is so small a quantity, however, that the metal might usually be better denominated iron.

The puddle-ball is as heterogeneous in its physical condition as in its chemical composition. It is irregularly porous, full of cavities of all sizes and shapes. The ductile metal is permeated with the brittle and non-coherent cinder in every part, and in all proportions. The skill of the puddler is displayed in reducing these defects, and in producing a puddle-ball of the greatest possible purity and homogeneity of character.

Even with the greatest care, the workman finally takes from the furnace a mass of barely cohering metal, dripping with liquid cinder, and the object of succeeding processes is

to reduce this sponge to the form of homogeneous, strong, and ductile plate or bar.

No process yet known, except absolutely remelting, can free the metal entirely from the cinder, and it consequently happens that all common iron made from puddled metal contains enough cinder to give it a fibrous character. The best irons have, however, an exceedingly fine and uniform fibre. Hence steel has largely replaced iron.

120. Mill Work comprehends the several processes by which the puddle-ball is converted into finished bar or plate. The first operation, that of shingling, or of squeezing, has for its object the removal of the cinder from the ball while still molten. The ball is transferred directly from the puddling furnace to be squeezed by the squeezer, or to be shingled under the hammer, and there compressed until the liquid cinder is forced out, as water is squeezed from a sponge by the hand, and the ball is compacted into a dense billet or bloom of wrought, or malleable iron. It has then the form either of a parallelepiped, or of a cylinder, and is at once carried to the rolls. The rolling mill reduces the bloom by repeated operations to the shape of a plate, or a bar, and to the dimensions required.

In most cases, the "muck-bar," as it is called after its passage through the first or puddle-train of rolls, is cut and laid up in "piles" of convenient size, and, after reheating in the reheating furnace, is rerolled.

Repetition of this process improves the quality, and increases the uniformity of the product. The iron is called, after once reworking, "merchant bar," and, after a second operation, "best bar," and "wire iron," or refined bar. The muck-bar, or puddle-bar, is rough on its edges, coarsely granular in the fracture, and has slight tenacity, but considerable hardness. Merchant bar is of ordinarily good quality, smooth, ductile, fibrous, and strong, and the rerolled metal is of the finest quality, and should be able to bear the severest of the tests described in a subsequent article. This reheating and reworking improves the quality of the metal by securing greater homogeneousness, and by the

removal of a portion of the carbon and silicon left in the puddle-bar.

The best Yorkshire (English) irons are made by the method just described. The puddle-balls, however, are beaten under the hammer into flat masses, about one foot (0.3 metre) square, and $1\frac{1}{2}$ to $2\frac{1}{2}$ inches (3.8 to 6.3 centimetres) thick, and these are then broken up for inspection and assorted, the best made into the finer grades of iron, and those of less excellent quality worked into cheaper iron. The best grades are thus produced of uniformly fine quality.

The shape and dimensions of the piles, as built up to go into the reheating furnace, preparatory to being rolled into bars or plates, vary with the shape and size of the latter. In making merchant bar, the piles are of such form that they are lengthened from 20 to 60 times in the process of rolling, and their cross section correspondingly reduced. To secure uniformity in the character of the finished iron this proportion should be varied as uniformly as possible, from piles for large bars, in which the least reduction takes place, to those for small bars, in which the work done on the metal is greatest. To secure the least possible loss of strength in making large bars the proportion of work done in rolling, and the decrease of cross section of pile, should be the greater, if possible, with larger sizes of bar.

"*Horseshoe iron*" is made of old horseshoes, worked into slabs or balls and rolled and rerolled, making the finest of iron.

In making the better grades of iron rails, the piles are built up of puddle-bar, and made of a section 8 to 10 inches (20 to 25 centimetres) square, and capped, top and bottom, with slabs of iron of good quality, in order to secure good wearing power.

These piles are hammered, or rolled, or first hammered and then rolled, into a bloom, or billet, which is again heated, and finally carried to the rail-train and rolled into a rail.

The rail, when taken from the rolls, is cut to proper length, straightened, punched, properly marked, and sent to market. Piles for beams are similarly made and worked.

Piles for plate-iron are made more nearly square, and are comparatively thin and flat. For the best plate, slabs of selected puddled iron are piled together, and are usually welded under the hammer into conveniently shaped masses, preparatory to rolling. Special shapes, and some heavy pieces, as shafts for large steam-vessels, are "fagoted" and worked to shape under the hammer. The piles for such work are either made of rolled bar, or of scrap-metal of various shapes, sizes, and kinds. Carefully selected scrap makes excellent iron, as it has already been well worked.

The process of fagoting consists in binding a considerable number of bars into a pile or fagot, and these fagots are worked under the hammer like piles made in the way already described. Shafts are lengthened by piling or fagoting at the ends, and gradually building them out by additional fagoting as the mass is worked into shape under the hammer. Railroad axles are made both by rolling and by shaping under the hammer as just described. Tires and bands are often made by rolling. Very heavy plates, as the armor plates of ships, are usually made by welding together, in the rolls, several thinner plates. They are sometimes built up under the hammer. The *hydraulic forging-press*, up to 10,000 tons capacity or more, now often supersedes the hammer.

Reheating is usually performed in a reverberatory furnace; melting pig metal for the purpose of charging rotary puddling furnaces is sometimes done in reverberatory furnaces, but usually in cupola furnaces—vertical furnaces cylindrical in form; in which the metal and fuel, with a small portion of flux, are charged as in blast furnaces, and from which the molten metal is drawn off at the bottom as required. Powerful blowing apparatus must be used to secure the needed air-supply.

121. Hammering.—The puddle-balls, when taken from the furnace, are compressed by either hammering or "squeezing" into blooms. At first, and frequently at the present time, heavy helve-hammers, Fig. 19, were used for this purpose. The hammer and its helve are usually of cast iron, although

the former is sometimes of oak or hickory. The weight resting on the anvil is from 5 to 8 tons (5,080 to 8,128 kilogrammes), the former being most frequently adopted. The hammer is raised by a revolving wheel with projecting wipers, or by a set of cams, which elevate the hammer to the necessary height, 15 to 20 inches (38 to 50 centimetres), and allow

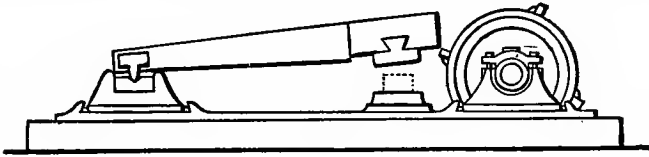

FIG. 19.

it to drop upon the puddle-ball. The rear end of the helve is carried by standards secured to a bed-plate, which extends under the anvil and cam-shaft bearings. The whole is mounted upon a foundation of timber and stone, or of timber alone, which frequently contains over 1,500 cubic feet (42.5 cubic metres) of oak. The whole structure weighs 30, or even 40 tons (30,480 to 40,064 kilogrammes), and covers a space of 20 to 25 by 6 to 8 feet (6 to 7 by 1.8 to 2.1 metres). The anvil block weighs 5 tons (5,080 kilogrammes) or more, the hammer itself nearly a ton (1,016 kilogrammes), and the helve several tons. The hammer makes from 50 to 75 blows per minute. When not in use, the end of the helve is caught at the extreme height of rise and supported by a prop.

When a puddle-ball is ready, it is laid on the anvil block and held by tongs in the hands of the hammer-man. The prop is knocked out, and the hammer, by a rapid succession of blows, works the ball into a bloom, the hammer-man meantime turning it from side to side, and sometimes presenting the end of the billet to the hammer. The bloom is taken from the anvil in a half minute, completely formed.

The steam-hammer, Fig. 20, in which the hammer is carried on the piston-rod of a steam engine, and rises and falls vertically, is now used to some extent. In that illustrated the piston-rod is very large, and the weight so great that no

“tup” is needed. The hammer-head is secured to the rod by a wedge-shaped ring, which is tightened up at every blow. The piston is welded to the rod. The valve-motion of the steam-hammer is usually made to work either automatically or by hand. That used for hammering puddle-balls is usually operated by hand.

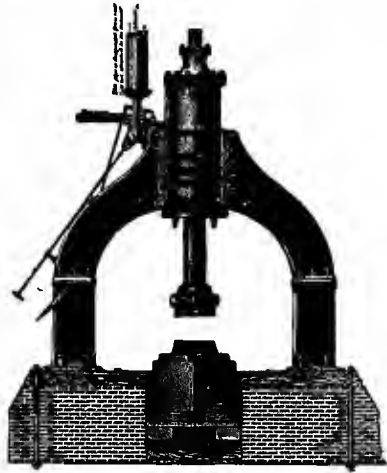

FIG. 20.

It is stated by iron makers that the impossibility of varying the intensity of the blow of the helve-hammer is an advantage not possessed by the steam-hammer. The expulsion of the fluid cinder from the puddle-ball is principally effected by the first heavy blows.

With the steam-hammer, the operator may strike light blows at first, and work the ball into a bloom of which the weight will be increased, but the quality seriously reduced, by the presence of an excess of cinder.

122. **The Squeezer** is now oftener employed than the hammer in compressing the puddle-ball: The older form, Fig. 21, is known as the “alligator” squeezer. It consists of an anvil-block, upon which the puddle-ball is laid, as in hammering, and a vibrating jaw, which alternately presses down

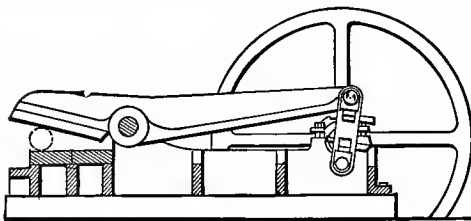

FIG. 21.

upon the puddle-ball and rises again to permit its manipulation by the workman. The jaw forms one end of a strong lever, pivoted near the working end, and operated by a crank-

shaft and link, or connecting-rod, at the opposite extremity. There are sometimes two compressing parts, one on each side the axis on which the lever vibrates. The machine is often driven by connecting its crank-shaft to the puddle-train, or roughing rolls, by a connecting-spindle or coupling, such as is used for connecting the roll train to its driver.

The jaw and the anvil may be kept cool by the circulation of water through them in small lap-welded iron pipes cast in them.

The parts of the squeezer are subjected to immense stresses whenever the puddle-ball has, by accident or negligence, been permitted to get too cool. The resistance of white-hot iron to compression is very small, and, at a bright red heat, is only one-fourth that of cold iron; but the resistance increases with very great rapidity as the metal loses its heat. The squeezer is necessarily made very strong to meet such accidental strains. The length of life of the several parts is stated to be often but a month for crank-brasses, and of parts exposed to strain simply from three months to a year.

The Rotary, the Burden, or the Cam Squeezer, as it is variously called, is very generally used in the United States, and to a considerable extent in Europe.

This consists of a large cam mounted, sometimes on a vertical and sometimes on a horizontal, shaft, and revolving within a fixed cast-iron cylindrical casing. The puddle-ball is inserted at one side, at the moment when the space between the cam and the casing is widest at that point, and it is seized by the cam and rolled around within the casing, gradually assuming a cylindrical form as the space grows narrower, and finally issuing in the form of a billet ready for the rolls.

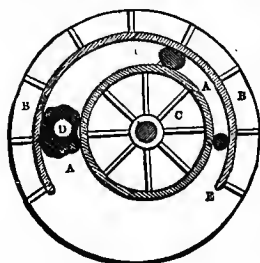

FIG. 22.—BURDEN SQUEEZER.

In another form the revolving shaft carries a cylinder instead of a cam, and the cylindrical casing is placed eccentrically to obtain a gradually diminishing space in which the billet is formed. This is the "Burden Squeezer." A

modification of the first of these forms has no casing, but the ball is compressed and formed between a vertical cam and a pair of rolls beneath it, on which rolls the puddle-ball is placed.

In some cases, the bloom is compressed lengthwise by the blows of a hammer while taking form in the squeezer. This gives a better and sounder bloom than can be obtained otherwise.

In still another form of squeezer, three pairs of rolls are used, one above another, the higher set being placed nearly on a level with the floor of the mill. The upper set are at such a distance apart that they will just seize the puddle-ball, and, compressing it somewhat, drop it between the intermediate rolls, which, in turn, deliver it still further compressed to the lower set, which turn out a finished bloom. The bloom drops from the third pair of rolls upon an apron, which raises it again to the floor of the mill.

123. Rolling Iron.—The puddle-ball is usually worked into a bloom five or six inches in diameter, and fifteen or eighteen inches long (12 to 15 by 38 to 45 centimetres), and is then taken to the rolling-mill.

These rolls are called the puddle-train or the roughing rolls, sometimes the breaking-down or the blooming rolls. In them the iron is first given the form of a bar, preparatory to being reheated and again subjected to the rolling process in the finishing train. The process of rolling was invented by Henry Cort, and at about the same time with his invention of the puddling process, the two inventions properly forming but details of one process. It was patented in 1784.

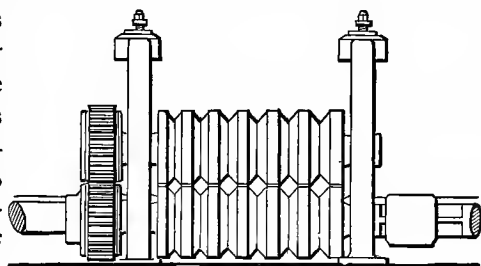

FIG. 23.—ROLLS.

124. The Common Form of Rolls, as adopted for both roughing and finishing, is shown in Fig. 23, in which

the roughing and a finishing train are shown as often driven together. These rolls, plain or grooved, are employed in making bars for the market, plate, flat bars for tram-rail and for beams, and for making wire rods. The finishing train for plates, beams, rails, and all kinds of heavy work, is gradually becoming superseded by either the "three-high" mill, or by the "reversing mill," to be hereafter described.

As usually made, the roll-train consists of pairs of heavy rolls so grooved that the bloom from the squeezer or the hammer may be readily entered at the first and largest grooves, where, passing through, it is reduced considerably in transverse dimensions and correspondingly extended, and can then be entered at the next groove, which is of smaller section. After passing through all the grooves in the roughing rolls, the slab or bar is sent to the next set or pair.

The first grooves in the first pair of rolls are often scored transversely, to insure their seizure of the bloom. The surfaces are hardened by casting the rolls in "chills."

The bloom, after each "pass," is lifted by the workman and sent back over the top roll to be entered again, and this is repeated until the mass has passed through all the grooves and is ready to enter the next set of rolls. This compression and change of form still further reduces the amount of slag in the iron. The operation results in the conversion of the rough bloom into a bar, which usually assumes a length of about 10 feet (3 metres), a breadth of 4 inches, and a depth of 1 inch (10 by 2½ centimetres).

The form of groove varies with the character of the work to be done. In the roughing rolls, as shown in the engraving, they are of such shape as to produce a bar of rectangular section. In the finishing rolls they are given a form which, in the first passes, is such as will take the bar or billet readily, and they change in form so as to gradually modify the section, finally delivering the bar in the form required. In small mills making light bar and wire iron, three rolls are used, one above the other, the middle roll turning in a direction opposite to the other two. In this case, the bar is entered on one side, between the lower and the middle rolls, and is returned between

the middle and the upper rolls, passing each way alternately, until it has gone through all the grooves, and finally emerges completely shaped.

The standards carrying the rolls are called " housings." The " body " of the roll is the portion between the housings. The " journals " are the portions within the housings, and support the rolls, while the ends, or " wabblers," project beyond the housings, and are seized and the rolls turned by the couplings and their connecting spindles. The bearings or " chucks " carrying the roll journals are capable of moving vertically in the housings. The lower box of the bearings of the lower roll is carried on the housing. The upper roll rides in bearings supported on the caps of the bearings of the lower roll, and is kept in position by the interposition of wedges between the two chucks, of which the lower is called the " carrier." Very strong screws, working through nuts in the top of the housings, bear upon the upper part of each box on the " riders " of the upper roll, and hold it down while the bar is passing through. The housings are supported by strong iron bed plates, to which they are bolted firmly. These plates are held down upon the foundation by heavy foundation bolts, and the foundation itself is deep and solid, and constructed of carefully laid masonry. The bed plates are sometimes made like a lathe bed, and the housings are thus rendered capable of lateral adjustment and of removal without inconvenience.

The connecting spindles are shafts of cast iron of such size that they will break under heavy strains more readily than the rolls, and from this fact they have been called " breaking spindles." The couplings which connect each end of the spindle to the roll, or driving shaft, are usually made weaker than the spindles. These pieces are fitted loosely to each other in order to permit considerable variation of position in the axes of the rolls without liability to breakage.

The rolls are made of a good and strong iron which will chill well. The housings are made of the very best and toughest iron, and the spindles and couplings of ordinary foundry iron.

“Rests” (pieces of wrought iron with edges of steel) are placed before the rolls and just below the level of the top of the lower roll upon which the bloom or bar is slid into the grooves, and “guides” are arranged on the opposite side to receive the bar and lead it from the rolls. Small roll-trains having guides on each side are called “guide-mills.” Without these guides small bars or rods are liable to “collar,” or, jamming in the grooves, wind about the roll. Heavy rolls for beams and rails are fitted also with side guides, to prevent lateral deviation. Wire brushes are also added, in some cases, to clean the issuing bars.

125. The Train is driven by a heavy shaft turned by the prime mover, which may be either a steam engine or a water wheel. A pair of gears, seen in the figure at the left of the train, and mounted in an independent pair of housings, connects the two lines of rolls. A line of water pipes is carried along the top of the train for the purpose of keeping the rolls and their bearings cool by a continually trickling stream.

The size of rolls varies with the character of their work. Heavy plate mills have rolls as large as 30 inches (76 centimetres) in diameter, and sometimes 8 feet (2.62 metres) or more in length. Twelve-inch and 8-inch (30 and 20 centimetres) trains are common sizes. Roughing rolls are 5 feet (1.5 metres) between housings, and 18 inches diameter.

The intermediate train, when one is used, and the finishing train, are carefully proportioned in general dimensions and in the graduation of the shapes and sizes of their grooves.

The rolls for plate mills are simply plain cylinders, and the thickness of the plate is determined by adjusting, at each pass, the screws which fix the position of the top roll. The ratios of successive reductions of section should be sensibly equal and, approximately at least,

$$r = 100 - 100 \div \sqrt[n]{\frac{S}{s}};$$

where n is the number of reductions, and S and s the areas.

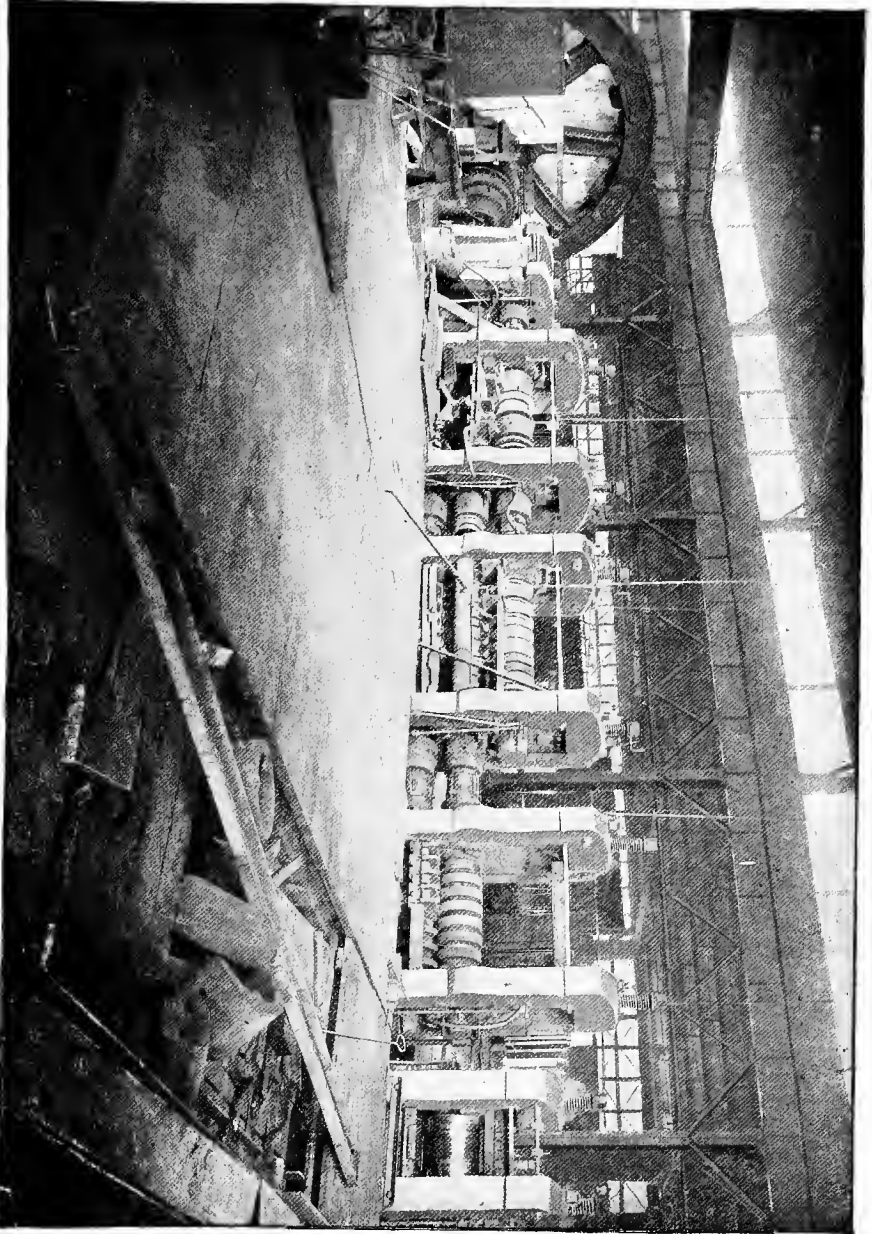

COPYRIGHTED BY CASSIER'S MAGAZINE, NEW YORK.

MERCHANT MILL. III. Co.

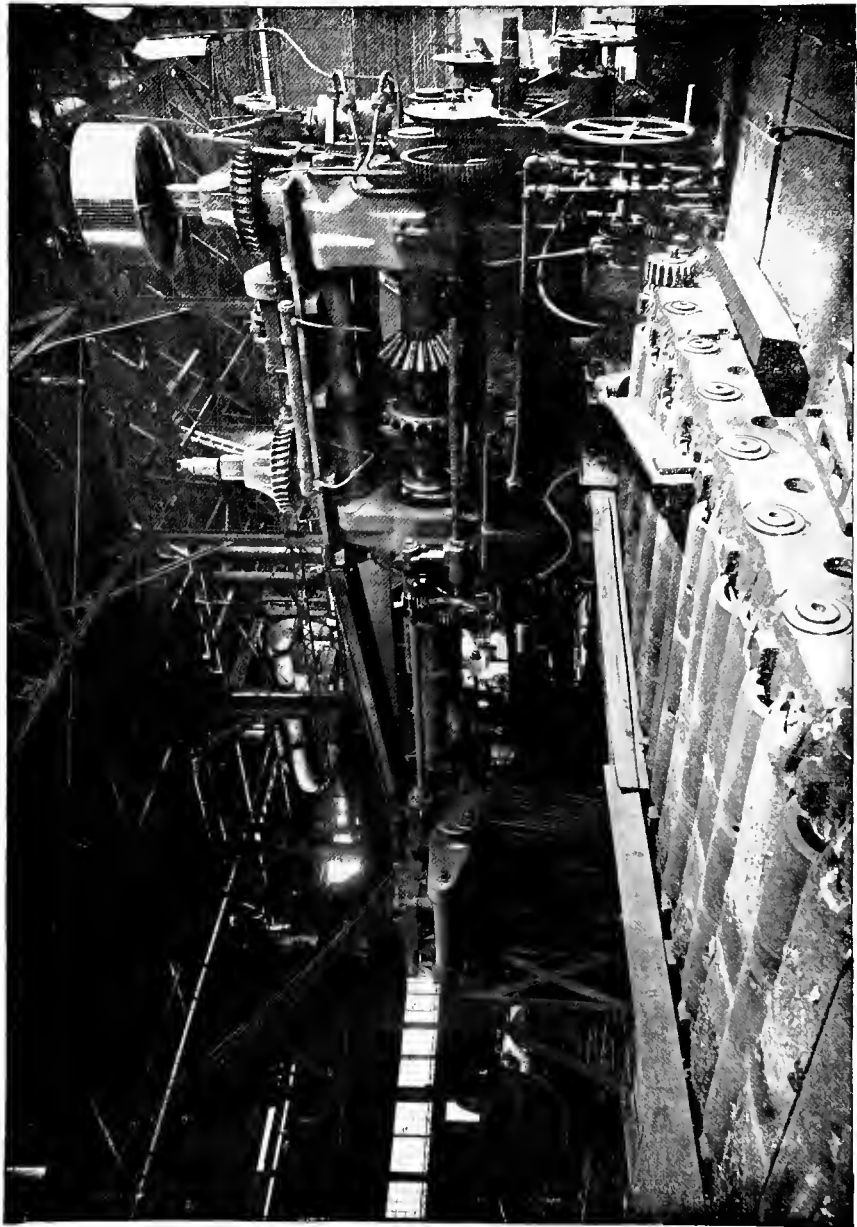

COPYRIGHTED BY CASBIE'S MAGAZINE, NEW YORK.

CARNEGIE PLATE ROLLS. (48-inch.)

126. In Rail and Beam Mills, collars project from the top roll, entering grooves in the bottom roll, and the space left between the collars and the bottom of the grooves is of the form and size required to shape the beam or the rail as it passes through in the groove. The larger parts of the bottom roll, separating the grooves, are called "collars," and that roll is known as the "collared roll." Similar rolls, having comparatively deep and narrow grooves and collars, are used for dividing flat iron into several small rods, and are called "slitting" rolls.

The velocity of the rolls varies with the character of the work, being greatest for light, and comparatively slow for heavy work. The extreme speeds for plate and bar mills are about 60 and 250 revolutions per minute respectively. Wire mills are driven very much faster.

127. The "Continuous Mill," invented by Bedson, consists of several sets of rolls, sometimes as many as sixteen, placed one in advance of the other, and each receiving the rod from its leader, and delivering it to its follower. It is used for rolling wire. A bar an inch ($2\frac{1}{2}$ centimetres) or more square, and 12 or 15 feet (3.6 or 4.5 metres) long, is heated throughout, and entered into the first pair of rolls. Passing from roll to roll, it is finally delivered as a long wire a quarter of an inch (0.6 centimetre) or less in diameter. The speeds are so adjusted that the rod is slightly drawn between each pair of rolls, and so that the rapidity of working is sufficient to keep up the temperature of the wire.

128. The "Universal Mill" is a form of mill in which the iron is acted upon in two directions, usually by horizontal and by vertical rollers, at each pass.

It was patented in 1853, and has received many modifications adapting it to special kinds of work. It is largely used for rolling beams, channel-bars, and girders.

As usually constructed, the universal mill consists of a pair of ordinary horizontal rolls, mounted in housings, and driven in the usual way, and of a pair of vertical rolls placed as close to the former as possible, and so mounted and driven that they can be moved toward or from each other

at pleasure by means of heavy adjusting screws, and the thickness of the pieces operated upon thus determined as by means of the housing screws of the horizontal rolls.

The adjusting screws are turned by a worm-shaft, which is operated by hand, usually, and engages worm-wheels on the heads of the screws. The vertical rolls are driven by bevel wheels and pinions, placed under the floor of the mill. To secure the lateral adjustment, the spur-pinion is made long enough to remain in action with its gear while the latter traverses with the roll.

129. The "Three-High" Mill consists of three rollers, as already stated, mounted in the same pair of housings, and driven together, the middle being, usually, the driving-roll, and revolving in the opposite direction from the others. This form of mill, when used for small work, requires no special appliances. For heavy work, it is fitted with various forms of mechanism, adapted to lifting the iron from the one level to the other. This mill has been used many years on small trains, but has not been, until recently, much used for heavy work.

In the best form of this device for rail-mills and beam-mills, the middle roll works into the bottom and top roll grooves, both of the latter being collared rolls.

The middle roll is somewhat larger than the bottom, to avoid liability of "collaring" taking place; and the top roll is still larger than the middle roll.

The guides, which receive and lead the rail or beam as it emerges from the rolls, are made slightly adjustable and yielding, as first designed by Mr. Charles Hewitt, to follow the rolls in their vertical adjustments. They are limited in range by a properly set cross-bar, which passes across their "heels." The guides are held up to their work by springs.

Vertical adjustments are effected by making the middle roll fixed, and the top and bottom rolls both movable.

In working with this mill, the bloom, ingot, or pile, whichever may be the form of the mass to be operated upon, is sent through the first groove, between the bottom and middle rolls, returned between the top and middle, and again

sent into a groove between the bottom and middle rolls, and thus sent forward and backward, until it leaves the last groove a finished bar.

The shape of the grooves and their relative sizes should be made such that no "fins" can be formed, by the protrusion of an excess of metal outside the groove into the space on either side between the rolls. Should a fin be formed, however, in any one groove, it is removed by becoming rolled down in the next groove.

130. The Reversing Mill is another mill in which the labor and expense attending the return of the bar from back to front at every pass in the ordinary "two-high" mill is avoided. It is a two-high mill in which the rolls are driven in such a manner that their motion can be reversed at each pass, and the bar brought back through the roll grooves. With the same speed of rolls, the work is done as quickly, and with the same number of movements, as in the three-high mill, just described. The reversal of motion, where the rolls are driven by a continuously moving engine or water-wheel, is produced by the use of a double clutch, keyed on the line of driving shafting and a train of three bevel-gears, of which two are loose on the clutch-shaft, and are driven in reverse directions by the third, which is keyed upon the engine-shaft. The clutch engaging the two gears, on either side of it, alternately, the rolls are reversed at each engagement.

In another form, the reversal is accomplished by attaching the driving engine directly to the rolls, and thus giving it the same speed of rotation. The engine has no fly-wheel, and consists of two steam cylinders with driving cranks placed at right angles to each other. The engine is thus so constructed as to be easily reversed, and this reversal with the rolls is produced at each pass by means of a shifting Stephenson link. For large engines, driving heavy rolls at high speed, the valve is moved by means of an hydraulic cylinder, so attached as to move the link.

The clutch is not found objectionable at very low speeds; but sudden reversal at high or even moderate speeds, is accompanied by serious shocks, and consequent strain and

danger of breakage. To avoid annoyance and danger involved in the use of the ordinary clutch, Napier introduced a "friction-clutch."

The use of the reversing steam-engine has been found satisfactory at all speeds, as its action is always easy and free from shock. It was first used by Ramsbottom, at Crewe, England, on rolls 24 inches (61 centimetres) in diameter, and 6 feet (1.8 metres) long, making 21 revolutions per minute, and giving a surface speed of 50 feet (9.1 metres) per minute to the rolls. The engines were geared to the train in such a manner as to give a piston-speed of 380 feet (115 metres) per minute.

131. The Distribution of Workmen at a heavy mill is as follows:

The pile, or bloom, is brought from the heating-furnace by the "buggyman," on an iron two-wheeled carriage, or "buggy," or in tongs suspended from an overhead railway, and he enters it in the first groove of the roughing-rolls. The "hookers-up," and the "catcher," under the eye of the "rougner," raise it and return it, and then pass it from one side to the other alternately, until it finally leaves the last groove, the "buggyman" assisting the other men by allowing the bar to fall on his buggy, and assisting in forcing it through the grooves. After the bar is transferred to the finishing rolls, the "finisher" takes charge, and the operation of rolling the now greatly extended bar is continued as before, until it leaves the last groove. It is then taken away to be straightened, and cut to the proper length.

Very heavy plates, as armor-plates, are received on buggies on each side of the rolls, instead of being caught on the rear side by the hooker-up. The lifting of the plate to return it over the roll in the two-high mill, when this is done at all, is usually done by steam or hydraulic lifts. Reversing mills are better for this work.

132. Hewitt's Mill.—The methods of raising and lowering the metal at the two-high, or at the three-high mills, are quite various. A table is frequently made to receive the bar, beam, or plate, and fitted with small rollers, over which the

metal may be easily slid. This table is, in some cases, raised and depressed by a steam-piston, and in other designs by hydraulic lifts. The table is usually counterweighted.

In a device invented by Mr. Charles Hewitt, a table on each side of the rolls is supported on a set of counterpoise levers, in such a manner that it shall have the height of rise needed. As fitted to the three-high mill, the table on the side on which the iron is first entered is given a greater rise than that on the opposite sides. For a middle-roll, 26 inches (6.6 centimetres) in diameter, Mr. Hewitt gives the two tables a rise of 31 and 21 inches (79 and 53 centimetres) respectively.

The two sets of levers are thus so proportioned that the one will carry its table from a point five inches below the lower grooves to a level with the upper grooves; while the other table carries the iron from a level five inches below the upper grooves to a level with the lower. By this difference of rise and fall on the opposite sides the inventor was able to secure such a difference of lever-arms, that the iron would be raised by the counterpoise on the one side, and would itself raise the counterpoise on that side in which the lever arms supporting the tables were longest.

In this arrangement, the weight of the iron does the work of transferring itself from one level to the other, and a small steam-engine or hydraulic press only is needed to control the apparatus.

A table moving transversely on the top of those just described permits the transfer of the iron laterally from groove to groove. In the plan here referred to, this lateral motion of the upper table is secured by attaching to each table an inclined rod, which rods are pivoted, each to its table at the upper end and to the floor at the lower end. As the table rises and falls, the attached rod pushes or pulls it to one side and to the other alternately.

As the rods are placed on opposite sides, the two upper tables move opposite ways laterally, although rising and falling simultaneously. The lower end of each rod is adjustable in a curved slot in a bracket secured to the floor, and the lateral movement of the table is thus made variable.

Mr. Hewitt uses water tanks as counterbalances, in order to secure a ready adjustment of weights.

133. The Power Required to Drive Rolling Mills is obtained usually from steam-engines, but sometimes from water-wheels. It is transmitted to the rolls generally by shafting and gearing. Gearing is sometimes avoided, on large trains by attaching steam-engines directly to the rolls, and on small trains belting is now coming into use.

In many mills the several trains of rolls are driven by one large and powerful engine; it is now becoming more common to drive each train by a separate engine of smaller size, and usually of high speed. The advantages of this plan consist in the independence of each train, and the safety thus secured against the stoppage of the whole establishment by the breaking down of one engine. The single engine must also usually be kept in motion continually, though often driving but a single train or a single tool. The independent engines can often be stopped, oiled up, and adjustments made without inconvenience, even during the regular working hours. The saving of steam in the latter case is sometimes important, and is further aided by the higher speed of piston and greater expansion secured by the directly attached engine.

In rolling-mill engines, a speed of piston of 800 feet (243 metres) a minute is sometimes attained, and 60 revolutions with a stroke of piston of five feet (1.5 metres), is not uncommon in late practice.

The amount of power demanded by rolling mills varies immensely with variations of size and character of work.

A puddling train consisting of a roughing mill, a pair of 18-inch (46 centimetres) finishing rolls, with squeezers and shears, rolling per week 250 to 350 tons (254,000 to 355,600 kilogrammes) of bar, 3 to 4 inches (7 to 10 centimetres) wide and $\frac{3}{4}$ to one inch (1.9 to 2.5 centimetres) thick, requires 40 to 50 horse-power when unloaded, and the resistance is nearly doubled when the iron is passing through the rolls. Such a train would be driven by an engine of about one horse-power for each four tons per week of product.

A rail-train is driven by a power of one horse for each

three tons of finished product per week, and produces from 600 to 900 tons (609,600 to 914,400 kilogrammes).

A "merchant-mill," producing small bars, requires from 80 to 100 horse-power to drive two trains of 18-inch (46 centimetres) rolls; a train of 12-inch (30.4 centimetres) rolls requires about 50 horse-power, and a train of 8-inch (20.3 centimetres) rolls, somewhat more.

A plate-mill, rolling plates $5\frac{1}{2}$ feet (1.06 metres) wide and $\frac{1}{2}$ inch (1.27 centimetres) thick, having rolls 30 inches (76.2 centimetres) in diameter, making 60 revolutions per minute, requires about 60 horse-power when running light, of which nearly one-third is expended on the fly-wheel journals, the wheel weighing about 30 tons (30,480 kilogrammes). The power required while the plate is in the rolls has been found, by experiment, to vary from 200 to 300 horse-power, of which a large proportion is alternately stored in and restored by the fly-wheel and moving parts of the roll-train. These figures are, however, subject to very great variation, and are rarely found to be capable of reduction to any practical rule for calculation.

The use of small, direct-acting, non-condensing engines, in place of the large beam engines once common, the introduction of three-high, high-speed, or reversing mills, of the universal mill, and especially the continuous roll mill, for small work, greatly reduce the amount of work demanded of the engine per ton of iron rolled. These, and the introduction also, in the United States especially, of belting in place of gearing, for the transmission of power to small roll-trains, are important steps in the direction of economy of power.

134. The Rate of Cooling while the iron is passing through the rolls varies greatly with the temperature at its first pass, and with the magnitude and shape of the mass. The smaller the ratio of cubic to superficial dimensions, the more rapid is the loss of heat. Wire cools very suddenly; large beams and heavy shafting cool quite slowly. The wire issues from the train comparatively cool, while the larger pieces are still red hot when laid on the floor. The more rapid the compression and reduction of section, also, the more

completely is the loss of temperature by conduction and radiation compensated by the generation of heat in the expenditure upon the metal of mechanical energy. A high speed of rolls is, in this respect, advantageous in making small bars and wire, and the number of passes is made as small as is possible without incurring liability to injury of rolls or of the bar by the squeezing of the metal outside the grooves, thus forming "fins," or of meeting with difficulty in entering the metal into succeeding grooves.

The hotter the iron the higher the velocity of the rolls, the greater their diameter and their strength, and the less marked the change in form of section, the greater is the amount of reduction allowable at each pass. Small rolls tend most to elongate, and large rolls to spread the metal. The designing of rolls with a view to securing rapid reduction and economy of time, labor and power, requires an unusual degree of skill, knowledge, experience, and good judgment.

135. **Efficiency of the Rolls.**—Making use of Rankine's formula for efficiency of axles (Machinery and Millwork, p. 431):

$$\text{Efficiency} = \frac{1 + \frac{fr}{m}}{1 + \frac{fr}{l}}$$

if r' is the radius of the body of the rolls, and r is the radius of the journal,

$$m = r \text{ and } l = r' - r.$$

Then the efficiency becomes

$$\text{Efficiency} = \frac{1 + f}{1 + \frac{fr}{r' - r}}, \dots \dots \dots (1).$$

in which f is the coefficient of friction.

In every case the friction of the journals adds to the resistance overcome by the driving power in the proportion

$$R = fL, \quad \dots \dots \dots (2).$$

in which R is the resistance at the roll-journal due to friction, f the coefficient of friction, and L the load on the journal.

Plate-iron, when passing through the rolls, is reduced in thickness from AB to DE , Fig. 24. Its resistance may be treated as constant during the small interval of time required in its passage, and is equal, per unit of area of metal, to p . The total load, L , thrown upon the journals

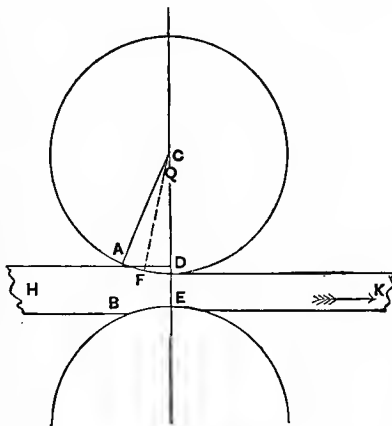

FIG. 24.

of the rolls, θ representing the angle of contact, ACD , and θ' the angle ACF , for any other point F , p the pressure per square inch in the metal, and l the length of the line of contact, will vary as $p l \int_0^{\theta'} \cos \theta d\theta$,

$$\begin{aligned} \therefore L &= p l \sin \theta' \\ &= \frac{p l A D}{r}. \quad \dots \dots \dots (3). \end{aligned}$$

The resistance offered by the plate or bar to the impelling effort acting in the direction HK , varies as $p l \int_0^{\theta'} \sin \theta d\theta$,

$$\begin{aligned} \therefore R'' &= p l \cos \theta' \\ &= \frac{p l \sqrt{r'^2 - AD^2}}{r'}. \quad \dots \dots \dots (4). \end{aligned}$$

Then the resistance, reduced to the driving point, becomes

$$R = \frac{pl\sqrt{r'^2 - AD^2}}{r'} \cdot \frac{1 + f}{1 + \frac{fr}{r' - r}} \cdot C \quad \dots \quad (5).$$

in which C is a constant representing the ratio of the speed of the driving point assumed to the speed of the point of application of the effort.

If v is the velocity of the driving point, and v'' that of the metal in the rolls, the work done per second, or the energy expended, is

$$Rv = C''R''v'' \quad \dots \quad (6).$$

in which C'' is a constant to be determined for each case by experiment.

The efficiency is

$$\text{Effic.} = \frac{R''v''}{Rv} = \frac{1}{C''} \quad \dots \quad (7),$$

where the units are the pounds, the foot, and the second. The value of the efficiency is, most frequently, below 0.5.

136. The Product of the Rolling Mill is either bar iron, plate, or sheet iron, beams, girders, or peculiar shapes made for special kinds of work.

The quality of the product of the rolling mill depends upon the original quality of the metal, upon the care taken in rolling, and upon the cleanliness of surfaces which are welded together in the process.

This will be considered at length when treating of iron as a material of construction.

The manager of the rolling mill endeavors to see that the puddling is efficiently performed, that the puddle-ball is made up as free as possible from cinder, that the cinder in the ball when taken from the puddling furnace is worked out as completely as possible under the hammer, or in the squeezers, that the iron is carried through the roughing-rolls while still at a proper temperature, that the reheating and

subsequent rolling is done at a good heat, that all surfaces are perfectly clean where they are to come in contact and to be welded together, and that cinder and scales of oxide are not allowed to collect on the metal or on the rolls, where they may produce roughness or depression in the finished surface of the iron.

A complete and rigid system of inspection and individual responsibility for work done should be instituted and kept up in every mill.

137. Forms of Wrought Iron.—The forms of wrought iron met with in market may be divided into six general classes, viz. :

1st. *Bar iron*, whose forms, round, square, and flat, are so generally known as to render little further description necessary.

Bars are usually known as either round, square, octagonal, or flat, according to the shape of their cross-section, and the former are rolled from less than one-quarter up to six inches in diameter. Except for shafting and chain cables, a greater diameter than $1\frac{1}{2}$ inches is seldom called for. Beams are seldom larger than 15 inches in depth, and are given an I-shaped section. Sheet iron is now used—boiler plate—as thick as $1\frac{1}{4}$ inches (3.2 centimetres), but the most common sizes are $\frac{1}{4}$, $\frac{5}{16}$, and $\frac{3}{8}$ inches thick (0.63, 0.78, and 0.95 centimetre). Their breadth is usually from 2 to 4 feet (0.61 to 1.22 metres), and length such as will not make them too heavy to be handled by three or four men. Armor plate has been rolled 26 inches (66 centimetres) in thickness.

2d. *Special forms* of bars, including :

Angle iron, having a section like the letter **L** ; it is rolled into lengths similar to bar iron (Fig. 34).

T-iron having a section like the letter **T** (Fig. 25).



FIG. 25.



FIG. 26.

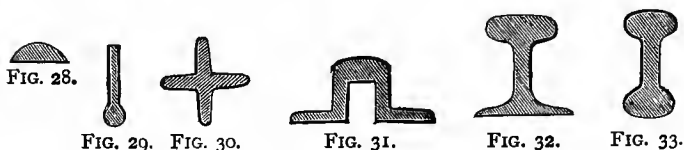

FIG. 27.

Channel iron (Fig. 26).

Beam iron (Fig. 27).

Half-round iron (Fig. 28).



Bulb iron (Fig. 29).

Feathered iron (Fig. 30.)

These several forms are designed to meet special requirements in bridge, house, or ship construction.

3d. *Rails.* The shapes now in use are :

Bridge rail (Fig. 31).

Flat-bottomed or **T**-rail (Fig. 32).

Double-headed rail (Fig. 33).

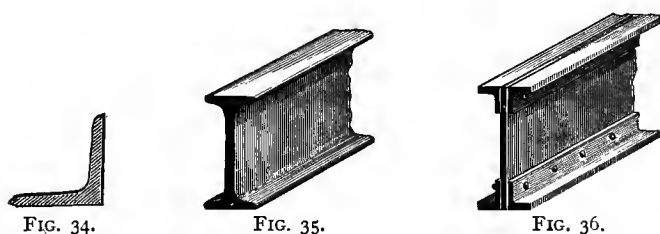

The flat-bottomed rail is the one in common use in this country.

4th. *Beams and girders*, either solid, as Fig. 35, or built up, as in Fig. 36.

5th. *Sheet iron*, of all shapes and sizes.

Special forms, not standard, can usually be obtained from the mill; but these, as well as odd sizes and irregular shapes, are charged for as extras.

The boiler-plate manufacturers have settled upon the nomenclature of plate-boiler thus:

(1st.) On and after January 15, 1881, the letters *C. No. 1* are to be dropped in stamping plate iron, and the word *Refined* be substituted therefor.

(2d.) On and after January 15, 1881, the letters *C. H. No. 1*

and *C. H. No. 1 Shell*, before used in stamping plate iron, are to be dropped, and the word *Shell* substituted therefor.

No change was made in the designation of flange iron, which remains "C. H. No. 1 Flange."

Originally, the best boiler plate for shells was stamped "C. No. 1," *i. e.*, "Charcoal No. 1," and the next grade "C. No. 2." Manufacturers of plates for marine boilers were, however, required to stamp the grade called for as a standard by the Navy Department, "C. H. No. 1," *i. e.*, "Charcoal Hammered No. 1." From that time the "C. No. 1" brand has been used for the second grade. But the same grade from different mills is not always of the same quality.

To get reliable boiler iron, the purchaser will buy plates bearing the private stamp of a reliable mill as well as the grade.

The old designations are still very generally retained, however, in the trade. Of these, "C. No. 1," Charcoal No. 1, is quite a hard iron, which does not flange well, and is used in boiler shells, and wherever it is not to be subjected to great changes of shape; its tenacity is usually about 40,000 or 45,000 pounds per square inch (2,812 to 3,295 kilogs. per sq. cm.). "C. No. 1 R. H." is a better grade, and makes a durable fire-box iron, but cannot usually be well flanged.

"C. H. No. 1 S." is sold especially for boiler shells and similar purposes; it is still stronger than the preceding; it is unfit for flanging. The tenacity of this iron ranges from 50,000 to 55,000 pounds per square inch (3,515 to 3,767 kilogs. per sq. cm.) tested lengthwise the sheet and about three-fourths this strength in the other direction. "C. H. No. 1 F.," Charcoal Hammered No. 1 Flange Iron, is of about equal strength with C. H. No. 1 S., but is more thoroughly refined, and is soft, ductile, and tough enough to flange well; its superior homogeneousness gives it nearly equal tenacity in both directions. "C. H. No. 1 F. B.," Charcoal Hammered No. 1, Fire-box Iron, is a harder and rather stronger iron, which may also be flanged. "C. H. No. 1 F. F. B.," Charcoal Hammered No. 1 Flange, Fire-box Iron, is a still better grade.

Single refined iron is that produced by cutting up the "muck bars" obtained by rolling the puddle-ball, piling, heating, and re-rolling it to size.

Double refined iron is that which is made by repeating the latter process, and rolling to size.

Good "double refined iron" is usually expected to have a tenacity in large pieces, as in bridge rods, of at least 50,000 pounds per square inch (3,515 kilogs. per sq. cm.), and an elastic limit, as generally measured, of 26,000 to 30,000 (1,848 to 2,109 kilogs. to the sq. cm.). It should bend double over a bar of its own diameter.

Compression members of structures are usually made of "single refined iron." Tension members are expected to be of better grade, and are made of "double refined iron."

6th. *Wire.*

138. Wire-Drawing.—As small rods cannot usually be reduced to the sizes distinctively classed as wire in the rolling mill, wire is generally produced by the process known as *wire-drawing*. The larger sizes above $\frac{1}{8}$ inch (0.32 centimetre) diameter are, however, often rolled, and especially where the iron is of too poor quality to permit it to "draw."

In ancient times, B.C. 1500, wire was made by hammering the metal into thin plates, and cutting from these plates very narrow square wires, which were subsequently hammered into cylindrical form.* Wire was also, B.C. 800, drawn down under the hammer directly.† As early as the beginning of the 14th century, it was made by drawing through draw-plates. Accounts of wire-drawing machinery appeared two centuries later, in Germany, and it was adopted in Great Britain as early as the middle of the 17th century, and gradually displaced the older method of production by hand, which was already giving employment to many workmen.

The "billet" is prepared for wire-drawing with exceptional care, and must, for small sizes particularly, be of the best obtainable metal. Ordinarily good iron will draw down to No. 14 (0.083 inch, 0.21 centimetre), and very good iron will draw

* Exodus, xxxix. 3.

† Odyssey, Lib. VIII.

to No. 25 (0.02 inch, 0.05 centimetre), but only the finest known iron can be drawn as fine as Nos. 30 to 36 (0.012 to 0.004 inch, 0.03 to 0.01 centimetre). Fine wire is made from selected scrap, or from the best grades of charcoal iron. In preparing the billet, the scrap-iron is melted down in a charcoal fire under a strong blast, and worked into a compact and homogeneous bloom. The bloom is hammered, re-heated in a reverberatory furnace, again hammered, and finally rolled into rods. These rods are cut up, piled, re-heated, and again rolled, the final product being wire-rods. The rolls used are from 8 to 12 inches (0.20 to 0.30 centimetres) in diameter, the former being used principally in the United States, and the latter in Europe. The former are driven at the rate of 450 to 500 revolutions per minute.

The rate of reduction is determined by the relative sectional area of the wire-rod and the billet, and their areas form the extremes of a geometrical series, of which the rate of reduction between successive passes is the ratio. Thus:

$$N = \frac{\log A - \log a}{\log r} + 1,$$

in which N is the number of grooves, A and a respectively the areas of the first and the last, and r the ratio.

Where $A = 2.28$ square inches, $a = 0.06$ square inch, and $r = 1.3$, N becomes 15, which may be taken to represent good practice. About 0.02 is allowed for the shrinkage in area in iron in cooling from the rolling heat to the temperature of the air.

The area of each groove is obtained by multiplying the area of the adjacent groove by the ratio of reduction.

In rolling, when the shape of cross section is changed from one simple form to another at each pass, the reduction is effected with greater economy of power. In rolling wire rods, therefore, the shapes of grooves are made alternately square and oval, oval and round, or feathered and square, or round, until the finishing grooves are reached, which give the rod its proper cylindrical form.

The finished wire rods are reeled up as they leave the rolls, and the coils are taken to a forge where the ends are made tapering, that they may readily be entered into the draw-plate and pass through so far that the point may be seized by the nippers or "grippers," by which they are to be drawn. The surface of the metal is cleaned thoroughly by immersion in dilute sulphuric acid and by subsequent washing, and is then covered with a coating of lime-water or other alkaline wash, to prevent oxidation during the operation of drawing.

The wire is then drawn by passing through draw-plates, or die-plates, of which the holes are made smaller and smaller until the wire is given the required size. As the metal is hardened by the process, it is annealed occasionally—usually after reduction two or three sizes—in annealing pots heated to a dull red heat, and by subsequent very slow cooling. A slight expansion takes place during this operation. The protecting coating must be renewed as often as it is removed by this process. To prevent oxidation while annealing, the wire is sometimes heated in a non-oxidizing atmosphere or in presence of some flux.

139. The Draw-Plates, or Die-Plates, are blocks of cast-steel perforated with conical holes carefully gauged, the smallest diameter of each being that of the wire to be drawn from it. These holes are frequently gauged by the workman, and, when worn, the metal is hammered around the small end of the hole to close it up, and then carefully reamed out to size again. The taper of these holes is best made slight, as in Fig. 37.



FIG. 37.

The wire-blocks, or wire-drawing machines, consist of a substantial bench on which is mounted a strong cast-iron drum, ordinarily about 2 feet in diameter for No. 10 (0.13 inch, 0.33 centimetre) wire, on which the wire winds as it is drawn through the plate. This drum is turned by a vertical spindle 2 inches in diameter, on which it is mounted, square projections on a cam mounted on the spindle entering recesses of similar form in the disk which forms the bottom of the drum. This cam or cross-head which drives the drum is carried by a square por-

tion of the spindle which passes through a hole in the cam. When the drum is raised far enough to clear the projections which drive it, it turns freely on the spindle, and can be rotated either forward or backward. A set of levers keeps the drum in any desired position, either engaged with the driving lugs or above them, where it may be conveniently turned or stopped at will. These levers are worked by the foot. In a later and better machine the drum is driven by a friction-cone instead of by a clutch.

The vertical spindle is driven by a horizontal shaft and bevel gearing, and the latter shaft by pulleys belted from the line-shafting.

The draw-plate is mounted on the bench in a frame strongly bolted down to the table.

The coil of wire to be drawn is mounted on a reel conveniently placed, and the end of the point, tapered sufficiently, is carried through the plate and seized by "nippers" or "grippers" attached to the driving cam.

The spindle being set in motion, the wire is drawn through the die-plate far enough to permit of its being securely clamped to the drum. It is then released from the nippers and made fast to the drum, which is then set in motion, and the coil is drawn through the plate, winding on the drum as it issues, and is now one size, and sometimes two sizes, smaller than before.

The moment of resistance in drawing No. 10 to No. 11 (0.134 inch to 0.12 inch, 0.34 to 0.3 centimetre), as given by experiments made for the Author, is about 350 foot-pounds (48.3 kilogrammetres); the velocity of the wire is about 250 feet (76 metres) per minute. Larger wire is drawn on drums of 1 or 2 inches ($2\frac{1}{2}$ to 5 centimetres) greater diameter and at lower speeds, reaching a minimum of 150 feet (45.6 metres) per minute. Smaller sizes are drawn on drums of 22 inch (56 centimetres) or less diameter, and at speeds running up to 500 feet (152 metres) per minute.

140. The Resistance offered by Wire in passing through the draw-plate varies with the size of wire, character of metal, and arrangement, proportions, and management of the wire-

blocks. Good metal, under ordinarily good conditions, requires, to reduce it one size, from 100 pounds (45.4 kilogrammes) with the finer, to 1,000 pounds (454 kilogrammes) of the larger grades. The ratio of reduction of area of section is usually about $1\frac{1}{2}$ to 1.

An approximate value for good wire is obtained by the empirical equation

$$P = \frac{30}{0.250 - d};$$

in metric measures,

$$P_m = \frac{14}{0.25 - 0.4d_m},$$

in which P is the pull and d is the diameter of the wire.

The velocity of drawing is, customarily, in feet per minute, nearly

$$V = 25N,$$

where N is the number of the wire on the Birmingham gauge.

The power demanded is, therefore, at the draw plate, in British measures,

$$\frac{PV}{33,000} = \frac{750N}{33,000(0.250 - d)}.$$

In drawing down billets, the heaviest work and greatest reduction of size take place in the "roughing" or "nipping" blocks, and no special attention is paid to the size or to gauging. The last drawing is done in the "finishing blocks," and the wire is carefully drawn precisely to gauge.

In "wet-drawing" the metal is drawn directly from the lees-tub in which it receives the alkaline coating, and the wire is thus preserved from oxidation, as is also the draw-plate, and is, at the same time, lubricated. Lime-

coated wire is drawn through grease. Bright wire is drawn dry.

Wire is often "coppered" by drawing it through a bath of solution of copper sulphate, or is tinned or "galvanized" by leading it through a bath of tin or of zinc kept at a temperature slightly above the melting point, to the finishing block.

When finished, sizes 0, to 20 are made up into "bundles" weighing 63 lbs. (28.6 kilos) each, and smaller sizes into "stones" of 12 lbs. (5.4 kilos) each. The smallest size ordinarily met with is No. 36 (0.004 inch, 0.102 centimetre diameter), but No. 40 (0.003 inch, 0.008 centimetre diameter) has been made.

141. Sizes.—Wire is gauged by the "Birmingham Wire Gauge" in Great Britain, and by the "American Gauge" sometimes, but not usually, in the United States. The table on page 202 gives the sizes of the standard numbers.

142. The Processes of Rolling and of Wire-Drawing, greatly increase the strength of iron. Good iron, which, in round bars, 2 inches (5.08 centimetres) in diameter, has a tenacity of 54,000 pounds (3,780 kilogrammes per square centimetre) per square inch, when rolled into one inch rods often attains a strength of 60,000 pounds (4,200 kilogrammes). When drawn into No. 10 wire (0.134 in., 0.34 centimetre), its strength becomes about 90,000 (6,300 kilogrammes), and Nos. 15 and 20 (0.072 and 0.035 in., 1.8288 and 0.88899 millimetres), respectively, have a tenacity of about 100,000 and 111,000 pounds per square inch (7,030 and 7,733 kilogrammes per square centimetre). A wire $\frac{1}{8}$ inch (0.31 centimetre) in diameter is ordinarily expected to sustain 1,000 pounds (454 kilogrammes), and one of $\frac{1}{32}$ inch (0.079 centimetre) diameter, should carry 100 pounds (45.4 kilogrammes).

In wire mills, great skill and judgment are necessary in choosing good metal, and in preserving its excellent qualities throughout the processes of reduction in the rolling mill and in drawing.

Good iron for fine wire must be pure, free from cinder, strong and ductile, and probably must have a comparatively

TABLE XXXV.

GAUGE OF WIRE.

NUMBER OF GAUGE.	DIAMETER, BIRMINGHAM GAUGE.		DIAMETER, AMERICAN GAUGE.	
	INCH.	MILLIMETRES.	INCH.	MILLIMETRES.
0000	.454	11.532	.46	11.684
000	.425	10.795	.40694	10.336
00	.38	9.6519	.3648	9.266
0	.34	8.6359	.32486	8.2511
1	.3	7.6199	.2893	7.3481
2	.284	7.2135	.25763	6.5437
3	.259	6.5785	.22942	5.8272
4	.238	6.0451	.20431	5.1894
5	.22	5.588	.18194	4.6212
6	.203	5.1562	.16202	4.1153
7	.18	4.572	.14428	3.6647
8	.165	4.191	.12849	3.2636
9	.148	3.7592	.11443	2.9065
10	.134	3.4036	.10189	2.588
11	.12	3.048	.090742	2.3048
12	.109	2.7686	.080808	2.0525
13	.095	2.413	.071961	1.8278
14	.083	2.1082	.064084	1.6277
15	.072	1.8288	.057068	1.4495
16	.065	1.651	.05082	1.2908
17	.058	1.4732	.045257	1.1495
18	.049	1.2446	.040305	1.0237
19	.042	1.0668	.03589	.9116
20	.035	.88899	.031961	.8118
21	.032	.81279	.028462	.7229
22	.028	.71119	.025347	.64381
23	.025	.63646	.022571	.5733
24	.022	.55879	.0201	.51054
25	.02	.508	.0179	.45466
26	.018	.4572	.01594	.40487
27	.016	.4064	.014195	.36055
28	.014	.3556	.012641	.32108
29	.013	.33096	.011257	.28593
30	.012	.3048	.010025	.25463
31	.01	.254	.008928	.22677
32	.009	.2286	.00795	.20193
33	.008	.2032	.00708	.17983
34	.007	.1778	.006304	.16012
35	.005	.127	.000614	.14259
36	.004	.1016	.005	.127
37004453	.11311
38003965	.10071
39003531	.08969
40003144	.07986

low elastic limit. It has been observed, that of two irons selected, both having great strength and ductility, that which stood lowest in *both* respects would draw into the finest wire. The only peculiarity detected by the Author, in this case, was a comparatively low elastic limit, as shown on the automatically produced strain-diagram.

Charcoal-bloom iron is usually found best adapted for wire-drawing if free from cinder and coal.

Very excellent metal has been made by the Bessemer and Siemens-Martin process for wire of sizes exceeding No. 10.

143. Irregular and Peculiar Shapes, which cannot be produced in the rolling mill, are given to wrought iron by the process of forging. This constitutes a trade, the methods and principles of which are properly the subject of a special treatise.

The art consists principally in working simple forms, as bar or plate iron, into more complicated shapes, by hammering at a bright red heat, and in making up larger masses and forming them as desired, by welding together smaller pieces. This work is sometimes done by the common hammer and sledge, and on the anvil and in formers by the blacksmith, sometimes under the steam or trip-hammer, or under the drop-press. It is also sometimes done under the hydraulic press. The practice of special methods, and the use of special tools for peculiar forms and sizes, is an important branch of the art. The conditions of success in doing this class of work are: the choice of iron free from sulphur and phosphorus, but containing some silicon where it is to be welded; working at a bright red heat, and welding at a white heat, or "welding-heat," with thorough fluxing; working rapidly, and with the least possible number of heats; and keeping the direction of "grain" as nearly as possible in the line of strain anticipated, and without breaking the fibre.

Irregular shapes and peculiar forms are made in cast iron by the processes of *moulding and founding*, which must also be described in detail in special treatises on that trade, on designing work to be made in cast iron, and on pattern-making.

The method, briefly described, consists in the preparation of a pattern, or mould, usually of wood, but sometimes of plaster or of metal—of the shape of the piece to be made, modified in some respects to avoid difficulties arising in moulding.

This pattern is imbedded in moulding sand, and, when removed, leaves an impression which has the shape of the casting which is to be made. Molten metal, poured into the mould thus made, solidifies in the desired shape. Cavities in the casting are produced, sometimes, by making similar cavities in the pattern, and moulding within them masses of sand, which displace metal in the mould so as to produce the proper form of cavity in the casting. Oftener, however, a projection is made on the exterior of the pattern, which corresponds in location and in its cross-section with the mouth of the opening desired. These "core-prints" leave in the mould impressions, into which the "cores" fit, and by which the latter are firmly held. The cores are masses of sand, which have been moulded in "core-boxes," and given precisely the shape of the cavity, but with extensions at those points at which the cavity comes to the exterior surface of the castings. These extensions fit into the impressions made by the core-prints, and the core is thus held in place while the molten metal is flowing around it.

144. The Work of Designing metal parts of machinery involves the intelligent consideration of the cheapest and most satisfactory methods of moulding those which are to be cast, as well as of forging parts made of wrought iron and steel. The pattern-maker must also know how to prepare the pattern, so as to avoid the difficulties frequently met with in moulding.

The moulder is required to know how to mould the piece in order to secure sound castings; and the founder must understand the mixing and melting of metals in such a manner as will give castings of the required quality. The engineer should know what forms can be cheaply made in cast metal, and what cannot be cast without difficulty, or without liability to come from the mould unsound. He should be

able to instruct the pattern-maker in regard to the form to be given the pattern in order to make the moulder's work easy and satisfactory, to tell the moulder how to mould the pattern, with what to fill his flask, and how to introduce the molten metal, and to provide for the escape of air, gas, and vapor, and he should be able to specify to the founder the brands and mixtures of iron to be chosen.

145. Malleableized Cast Iron, or malleable cast iron and steel castings, are castings made originally of ordinary cast iron, which have been subjected to a process of decarbonization which results in the production of a crude wrought iron. The process is conveniently applicable only to small castings, although pieces of considerable size are sometimes thus treated. Handles, latches, and other similar articles, cheap harness mountings, ploughshares, iron handles for tools, wheels and pinions, and many small parts of machinery are made of malleable cast iron, or as steel castings.

For such pieces, charcoal cast iron of the best quality should be selected in order to insure the greatest possible purity in the malleable product.

The castings are made in the usual way, and are then imbedded in oxide of iron—in the form, usually, of hematite ore—or in peroxide of manganese, and exposed to the temperature of a full red heat for a sufficient length of time to insure the nearly complete removal of the carbon. The process, with large pieces, requires many days.

If the iron is carefully selected, and the decarbonization is thoroughly performed, the castings are nearly as strong, and sometimes hardly less malleable, than fairly good wrought iron, and they can be worked like that metal. They will not weld, however.

The pig-iron should be very free from sulphur and phosphorus. The best makers have usually melted the metal in crucibles having a capacity of 50 to 75 pounds (22 to 34 kilogrammes), keeping it carefully covered to exclude cinder and other foreign matter.

The furnace is similar to that of the brass foundry, from 2 to 2½ feet (0.6 to 0.75 metre) square, and the fire is kept up

by natural draught. The temperature is determined with sufficient accuracy for the practical purposes of the founder by withdrawing a portion on an iron bar. If hot enough, the drop burns on exposure to the air. If right, the metal is poured quickly.

The "cementation," or decarbonization, is conducted in cast-iron boxes, in which the articles, if small, are packed in alternate layers with the decarbonizing material. As a maximum, about 800 or 1,000 pounds of castings are treated at once. The largest pieces require the longest time. The fire is quickly raised to the maximum temperature, but at the close of the process the furnace is cooled very slowly. The operation requires from three to five days with ordinary small castings, and may take some weeks for large pieces. This process was invented in 1759.

Decarbonization is often performed, in the production of steel castings, by a process of dilution accompanied with, possibly, some "dissociation." By the preceding method the carbon takes oxygen from the surrounding oxides, and passes off as carbon monoxide (carbonic oxide); in the process now referred to the carbon of the cast iron is shared between the latter and the wrought iron mixed with it in the melting pot, and a small portion may possibly pass off oxidized. The latter method has been practiced to some extent for a century.

Selected cast iron and good wrought iron are melted down together in the crucible and cast in moulds like cast iron. The metal thus produced contains a percentage of carbon, which is determined by the proportions of cast and wrought iron in the mixture. The amount is so small, frequently, that the castings made can be forged like wrought iron. The process is properly a steel-making process, and will be considered at greater length when treating of the manufacture of steel.

146. Tin-Plate is sheet iron coated on both sides with a very thin layer of tin. The market is supplied with two kinds: charcoal plate, and coke plate.

The blooms intended for manufacture into tin-plate are

prepared in Wales, whence the greater part of the tin-plate in the market is received, by refining with charcoal and reworking after reheating in a coke fire.

The metal selected is usually perceptibly red-short, the effect of sulphur, although deleterious at a high temperature, being to confer upon the metal exceptional toughness when cold. Steel has gradually taken the place of iron.

The pig-iron loses about 25 per cent. of weight in refining and conversion into bar. The bar is usually about 30 feet (9.1 metres) long, 6 inches (15.2 centimetres) wide, and $1\frac{1}{2}$ or $1\frac{3}{4}$ inches (3.8 to 4.4 centimetres) thick.

The bars are cut up into pieces a foot long, piled, reheated, and rolled into finished bars, losing again about 25 per cent. in weight, and taking about $\frac{5}{8}$ or $\frac{3}{4}$ ton (635 to 762 kilogrammes) of coke per ton (1,016 kilogs). The short finished bars are given such size and proportions as best fit them to be worked into plate of the thickness and other dimensions proposed. The bars, cut to proper length, are taken to the rolling mill, where they are reheated in a reverberatory furnace, rolled, doubled, and reheated, and again rolled, the rolling being repeated from four to six times, and the bar gradually assumes the form of a small, rectangular sheet, which, after being sheared to gauge, is ready for the operations preparatory to tinning. In rolling the bar, it is passed through the rolls with its axis parallel to that of the roll. Throughout these processes the greatest care is taken to keep the metal, when heating it, under a deoxidizing flame, and to avoid every cause of injury of surface, as by the formation of scales.

The pile of plates, brought finally from the rolls, is "opened," the sheets separated, each bar having made, usually, eight or sixteen sheets. The more frequently they are doubled, the greater the waste in rolling.

The plates are next "pickled," in a bath of dilute sulphuric or hydrochloric acid in leaden vessels heated by a fire beneath, are then washed thoroughly two or three times, and finally dried and annealed by heating in tight boxes to a bright red heat, and slowly cooled.

The annealed plates are "cold rolled" between very

smooth and accurately turned rolls, again annealed at a moderate temperature, and pickled and washed again. Those which are not well cleaned and smooth are scoured with fine sand, and all are singly examined and are handed to the tinner as nearly as possible absolutely clean.

147. The Tinning is done by a "gang" consisting of the "tinman," the "wash-man," the "grease-boy," and the "list-boy." The first receives and inspects the plates and places them in a trough of clean water, whence they are taken as required and immersed in a vessel containing warm melted grease. When well coated with grease they are put into the "tin-pot" and submerged in molten tin, the surface of which is flooded with grease, and kept clean by plunging into it wooden sticks, the gas and vapor evolved from which carry impurities to the surface, and check oxidation. This tinning is repeated in the "wash-pot," which contains tin of better grade, and at a lower temperature, and the plates are again carefully brushed and cleaned, and, finally, are dipped into another compartment of the wash-pot, in which they take a coating of the best quality of tin. The plates are then removed to the "grease-pot," in which, under grease, a small quantity of tin is kept at a temperature exceeding the melting-point, the superfluous metal is drained off the plates. On removal, they are cooled in the "cold pot."

The "list pot" contains molten tin in a pool at the bottom, only about a quarter of an inch deep. The line of tin of excessive thickness, which forms at the lower edge of the plate when draining and cooling, is here melted off, and the plates are scoured with bran and woolen cloths, and are ready for inspection, classification, and packing for market.

148. A Box of "IC" plates contains 225 sheets, each $13\frac{3}{4} \times 10$ inches, and, if standard, weighs 112 pounds. If not less than 109, nor more than 115, the box would pass in the market. A box of "HC" tin weighs 119 pounds; one of "IX" weighs 140; one of "IXXXXXX" weighs 245. "D" plates are packed 100 in a box, are $16\frac{3}{4} \times 12\frac{1}{2}$, and weigh from "DC," 98, to "DXXXX," 189 pounds.

In making coke plates, the cast iron is refined, and is

usually puddled instead of being decarbonized in the refinery. The loss of metal is about the same.

"*Terne-plates*" are tinned with an "alloy" of tin and lead; the proportion of tin varies from one-third to two-thirds. These plates are largely used for roofing.

149. Russian Sheet-Iron is a thin sheet iron used for purposes requiring a smooth polished surface, which is not likely to oxidize readily, as for stove-pipe. The bright surface coating consists of iron oxide. It is made of a fine quality of wrought iron, rolled and annealed. The polish is given by hammering packages of the sheets with charcoal interposed. The best is imported from Russia; but less excellent iron of this class is made in other countries.

In Russian works, selected iron is hammered into slabs of the right size to make each a finished sheet. The slab is passed through the rolls three or four times, and subsequently hammered again. Several sheets are then heated to a full red heat, covered with charcoal shaken on them from a bag made of coarse linen, and piled with covering sheets of heavier iron, top and bottom. The pile is then worked down under a heavy hammer, nearly to the finished size. When cool, the hammering ceases, the plates are separated, reheated, and piled again with cold plates interposed, the hot and cold sheets alternating in the pile, and hammering them until cool, they are finished. They are then separated, cut to size, weighed and assorted for the market. The loss of metal in the manufacture is sometimes 30 per cent.

The sheets are usually about 5 feet by $2\frac{1}{2}$ (1.6 by 0.8 metres) in size, and weigh from 6 to 12 pounds (2.7 to 5.4 kilogs), exceptionally heavy plates being made, however, weighing 30 pounds (13.6 kilogs).

The rolls make 75 or 80 revolutions per minute, and require driving power of about 40 horse-power. The hammers have very broad faces.

The finished sheets should be capable of being bent from four to six times without cracking.

CHAPTER VII.

THE MANUFACTURE OF STEEL.

150. Steel is variously defined by acknowledged authorities, and the metals known in the market and to the trade as steel cannot be completely and satisfactorily classed under any definitions yet proposed.

The term includes, as formerly accepted, all impure irons which, in consequence of the presence of other elements, have the property of hardening by sudden cooling from a high temperature, and of taking a definite "temper," or degree of hardness, by a definite modification of temperature, and which may also be forged.

It has been more recently proposed to define steel as a compound consisting principally of iron, which has been rendered homogeneous by fusion; still another definition is "iron recarbonized." The first definition is based upon composition and properties; the others upon the method of manufacture. The latter compels the engineer to ascertain the history of the metal before he can give it a name. The trade has practically adopted the last method of nomenclature.

An international committee, appointed at the instance of the American Institute of Mining Engineers, in the year 1876, recommended the following nomenclature:

I. That all malleable compounds of iron with its ordinary ingredients, which are aggregated from pasty masses, or from piles, or from any forms of iron not in a fluid state, and which will not sensibly harden and temper, and which generally resemble what is called "wrought iron," shall be called **WELD-IRON** (German, *Schweisseisen*; French, *fer soudé*).

II. That such compounds, when they will, from any cause, harden and temper, and which resemble what is now called

“puddled-steel,” shall be called WELD-STEEL (German, *Schweiss-stahl*; French, *acier soudé*).

III. That all compounds of iron with its ordinary ingredients, which have been cast from a fluid state into malleable masses, and which will not sensibly harden by being quenched in water, while at a red heat, shall be called INGOT-IRON (German, *Flusseisen*; French, *fer fondu*).

IV. That all such compounds, when they will from any cause so harden, shall be called INGOT-STEEL (German, *Fluss-stahl*; French, *acier fondu*).

As arranged by Wedding, the following is the scheme of the system :

Iron.	{	Forgeable; difficult to melt :	I.	{	Obtained in a fluid state :	{	Hardening :
		Forgeable iron			A. Ingot iron.		1. Ingot steel.
		Not forgeable; easy to melt :			Obtained in a non-fluid state :		Not hardening :
		Pig iron.			B. Weld iron.		2. Ingot iron.
							Hardening :
							3. Weld steel.
							Not hardening :
							4. Weld iron.
							C. White pig.
							D. Gray pig.

There may be added, called as formerly, *Remelted pig iron*—cast iron; *remelted steel* of every description—cast steel. Here the division following the fluid or non-fluid state keeps the principal place; the hardening only the second.

The grades are practically distinguished quite readily, thus:

I. and II. by their capability of being readily forged, or otherwise; A and B by their characteristic fracture; C and D by their color. Or, by chemical analysis, according to Wedding, the percentage of carbon will be :

Iron	{	I. contains from 0.0 to 0.3 per cent.	{	Steel	{	1 from 0.6 to 3 per cent. C.
		2 and 4 contain from 0 to 0.6 per cent.				3 from 0.6 to 3 per cent. C.
		II. contains 2 to 3½ per cent.				

The higher figure for steel is unusually large.

The American Institute of Mining Engineers, discussing the report of the International Committee on Nomenclature,

rather than by a chemical analysis. The basis is the measured elongation of specimens of standard size broken by tension; and nine grades are made, covering a range of 16 per cent. elongation in division A, 19 per cent. in division B, and 22 per cent. in division C. The test-bars are of 0.31 square inch (200 square millimetres) section, and 0.3937 inch (1 centimetre) long in the neck, and are hardened in oil. The elongations are as follows:

NO. OF GRADE.	1	2	3	4	5	6	7	8	9	10	11
A, { per cent. of elongation..... }	13	15	17	19	31	23	25	27	29
B, " "	13	15	17	19	31	23	25	27	29	32	..
C, " "	13	15	17	19	31	23	25	27	29	32	35

The addition of carbon to iron hardens the metal, decreases its ductility and its malleability, and renders it more fusible and less resilient. When in higher proportions than one-half per cent. and less than two per cent., it makes a steel capable of being hardened, and of taking a temper.

An accepted Swedish classification (Siljanfors), according to Grüner, is the following:

NUMBER.	CARBON.	CHARACTERISTICS.	
		Welds.	Forges.
1	0.0200	No.	With difficulty.
1½	0.0175	No.	Fairly. .
2	0.0150	No.	Well.
2½	0.0125	With difficulty.	Quite well.
3	0.0100	Yes.	Very well.
3½	0.0075	Readily.	Very well.
4	0.0050	Well.	Very well.
4½	0.0025	Excellently.	Perfectly.
5	0.0005	Perfectly.	Perfectly.

The last two grades are classed as hard and homogeneous irons, respectively.

An Austrian official classification is the following:

NO.	CARBON.	CHARACTERISTICS.	
1	1.58 to 1.38 per cent.	Will not weld.	Seldom used.
2	1.38 to 1.12 "	Will weld.	Used for hard tools.
3	1.12 to 0.88 "	Welds fairly.	Used for chisels, etc.
4	0.88 to 0.62 "	Welds quite easily.	Used for files, etc.
5	0.62 to 0.38 "	Welds readily.	Used for rails and tires.
6	0.38 to 0.15 "	Will not temper.	Used for boiler plates.
7	0.15 to 0.05 "	Will not temper.	Substitute for iron.

Steel is usually classified in the United States by its percentage of carbon, but sometimes by physical tests. In one example, four grades of steel for tires, axles, and forgings, are thus distinguished: *

CLASSES.	I.		II.		III.		IV.	
	Lbs. per sq. inch.	Kilos. per sq. cm.	Lbs. per sq. inch.	Kilos. per sq. cm.	Lbs. per sq. inch.	Kilos. per sq. cm.	Lbs. per sq. inch.	Kilos. per sq. cm.
Tenacity.....	67,800	4,746	79,600	5,572	86,500	6,055	94,000	6,580
Limit of elasticity.....	33,000	2,310	37,000	2,590	43,000	3,010	46,500	3,255
Elongation, per cent.....	26		23		20		17	
Reduction of section, per cent	52		44		39		36.7	

These metals are all low in carbon.

A very complete classification for the market by analysis is illustrated by the following, which is given by Metcalf:

NUMBER.	CARBON.	DIFFERENCES.	IRON.
1	0.00 302	99.614
2	0.00 447	0.00 145	99.454
3	0.00 564	0.00 117	99.363
4	0.00 719	0.00 155	99.270
5	0.00 801	0.00 082	99.119
6	0.00 848	0.00 047	99.085
7	0.00 867	0.00 019	99.044
8	0.00 869	0.00 002	99.040 "
9	0.00 947	0.00 078	98.900
10	0.01 005	0.00 057	98.860
11	0.01 047	0.00 042	98.752
12	0.01 097	0.00 052	98.753
Mean		0.00 072	

* These figures are probably sufficiently exact to be comparable.

These grades are selected by the eye, all ingots being "topped"—*i. e.*, having the top broken off—before being rolled, inspected, and assorted into these grades.

Although the proportion of carbon mainly determines the grade or temper of a steel, other elements frequently, and sometimes greatly, modify its quality. Silicon, manganese, chromium, sulphur, and phosphorus, are the most common of these modifying ingredients. Steels made by alloying iron with tungsten, chromium, and titanium, are sometimes called "compound" steels.

The distinction which is often made between irons and steels according to method of manufacture, and which classes metal made by any process involving welding, and metal made by melting and casting into ingots as steel, is sometimes made the basis of a double classification of steels, thus :

CARBON, PER CENT.	WELDED METAL. ("IRONS.")	CAST METAL. ("STEELS.")
0 to 0.25	Common iron.	} Very soft steel. } "Homogeneous metal." Soft steel. Semi-soft steel. } Hard steel. } Tool steel.
0.15 to 0.45	Granular iron.	
0.45 to 0.55	Steely iron; puddled steel.	
0.55 to 1.50	Cemented iron or steel.	

One of the largest makers of Europe divides all steel into four classes :

1st Class.—Extra mild steels. Carbon, 0.05 to 0.20 per cent. Tensile strength, 25 to 32 tons per square inch. Extension, 20 to 27 per cent. in 8 inches of length. These steels weld and do not temper. Used for boiler-plates, ship-plates, girder-plates, nails, wire, etc.

2d Class.—Mild steel. Carbon, 0.20 to 0.35 per cent. Tensile strength, 32 to 38 tons per square inch. Extension, 15 to 20 per cent. Scarcely weldable, and hardens a little. Used for railway axles, tires, rails, guns, and other pieces exposed to heavy strains.

3d Class.—Hard steel. Carbon, 0.35 to 0.50 per cent.

Tensile strength, 38 to 46 tons per square inch. Extension, 15 to 20 per cent. Do not weld, but may be tempered. Used for rails, special tires, springs, guide-bars of steam-engines, pieces subject to friction, spindles, hammers, pumps.

4th Class.—Extra hard steel. Carbon, 0.50 to 0.65 per cent. Tensile strength, 46 to 51 tons per square inch. Extension, 5 to 10 per cent. Do not weld, but may be strongly tempered. Used for delicate springs, files, saws, and various cutting tools.

The peculiarities and the characteristics of the several grades of carbon steels, and the differences produced by the introduction of the various metallic and non-metallic elements found in manufactured steels, and the modification of quality produced by special treatment, will be described at length in a chapter on the properties of steel.

The International Committee's classification may be put in the following convenient form:

I. CANNOT HARDEN—IRON.		II. CAN HARDEN—STEEL.	
<i>Puddled iron.</i> <i>Bloomary iron.</i> <i>Malleable castings.</i> <i>Bessemer iron.</i> <i>Siemens-Martin iron.</i> <i>Crucible iron.</i>	A, has not been fused— <i>weld iron.</i> B, has been fused— <i>ingot iron.</i>	Weld Metal. Ingot Metal.	A, has not been fused— <i>weld steel.</i> B, has been fused— <i>ingot steel.</i> <i>Blisters steel.</i> <i>Puddled steel.</i> <i>Shear steel.</i> <i>Bessemer steel.</i> <i>Siemens-Martin steel.</i> <i>Crucible steel.</i>

151. The Steel-Making Processes may be divided into three classes: (1.) That which includes those steels made of malleable or wrought iron carburetted; (2.) That which comprehends all processes in which metal rich in carbon, as common cast iron, is partially decarbonized; (3.) That in which highly carburetted iron is first completely decarbonized and then recarbonized to the proper degree in a single process.

The common "Crucible Process" is of the first class; one form of the pneumatic process, and the ordinary methods of making "Puddled Steel," belong to the second; while the now generally practiced pneumatic method known as the Bessemer process, and the "Siemens-Martin Process," are examples of the third class.

Many steel-making processes are known, and several are extensively practiced. Those best known, and which furnish nearly all the steel found in the market, are the Crucible, the Bessemer, and the Siemens-Martin processes. Direct reduction from the ore, and the manufacture of steel by puddling, are less generally practiced.

The processes of steel-making are not subject to the same uncertainty of nomenclature as their products. Although either process may yield a product which is not indisputably a steel, there is no serious disagreement of authorities in the classification of methods.

The following is that adopted by the Author :

(1.) "*Direct*" processes of reduction from the ore, as the bloomy process ;

(2.) *Carburization of Wrought Iron*, as in the cementation process ;

(3.) *Decarbonization of Iron* rich in carbon, as in the Bessemer process.

The Carburization of Wrought Iron may be performed in either of several ways, as :

(2a.) By fusion with solid carbon or with solid compounds of carbon.

(2b.) By heating, in presence of solid carbon compounds, without fusion.

(2c.) By heating in the presence of gaseous carbon, and without fusion.

Decarbonization of highly carbonized iron may be secured :

(3a.) By fusing in contact with solid oxidizing materials ;

(3b.) By fusion in presence of gaseous oxygen ;

(3c.) By heating without fusion, in contact with solid oxidizing materials ;

(3d.) By heating, without fusion, in an atmosphere of oxidizing gases.

The following are examples of each :

DIRECT PRODUCTION.

(1.) The bloomy process ; Siemens' ore process.

CARBURIZATION.

(2*a.*) The production of crucible steel by fusion of wrought-iron with carbon. The production of Siemens-Martin steel by fusion of wrought and cast-iron together.

(2*b.*) The production of cement, or blister steel, and of Wootz or Indian steel, by heating iron in presence of carbon, and the method of partial conversion known as case-hardening.

(2*c.*) The method of producing steel by heating in an atmosphere of carbon-laden gases, such as hydrocarbons, as proposed by Mackintosh and others.

DECARBONIZATION.

(3*a.*) The process of producing puddled steel by "boiling"; of decarbonizing cast iron by fusion in presence of oxidizing salts, as nitrate of soda in the Heaton process; the fusion of cast-iron with ore, as proposed by Uchatius.

(3*b.*) The fusion in presence of air or of other oxygen-laden atmosphere, as in the Bessemer process, and in Peter's and Wilson's processes.

(3*c.*) The processes of making "steel castings" by heating castings of iron in a bed of oxide or other solid material rich in oxygen.

(3*d.*) The process of reduction of cast-iron to steel by heating in an atmosphere containing oxygen and nitrogen, as in common air, such as: Turner's method of heating in sand; Herzeel's method of heating in steam; and Thomas's use of carbonic acid.

There are two processes by which metal already made, whether steel or iron, is rendered more perfectly homogeneous. These are:

(1.) By cutting up into pieces of convenient size and shape, piling and hammering, the operation being repeated until the desired degree of uniformity is secured.

This process may give a product which will approximate but can never fully attain, thorough homogeneousness,

nor can it give freedom from mechanically combined impurities.

(2.) By melting the metal, purifying while in fusion, and casting it into ingots or other desired shapes.

This method secures the greatest possible refinement of product by permitting both mechanical separation and thorough fluxing out of impurities.

152. The Direct Processes of Making Steel from the ore, have, as stated, been practiced from very early times. The primitive methods of ore-reduction probably frequently produced steel, and all nations, of even pre-historic times, when familiar with iron, have probably also been acquainted with steel.

The Catalan process, which ordinarily produces iron, may, by the use of an excess of fuel, be made to yield steel. In such case roasted spathic ores are frequently used, and the tuyeres are set nearly horizontal. With care and skill, a marketable product may be obtained. This "natural steel" has been made by the direct method in India and Burmah for many centuries, and is still made in Corsica and Catalonia.

From the time of Leucas, 1791, to the present, many attempts have been made to devise a direct process of steel making by the addition of carbon-supplying material to the ore, which should yield a valuable quality of metal with such economy and certainty as to secure for it a market; but, up to the present time, all extensively practiced methods are of the indirect class, and produce steel from manufactured iron. The carbonizing material is usually a solid fuel, as charcoal or coke; but, in some cases, liquid or gaseous hydrocarbons have been used. In the direct processes, the steel is usually obtained in the form of a ball or sponge, and its treatment is that adopted when iron is the product.

One of the best known of modern direct processes is that of C. W. Siemens. It is conducted in a rotating furnace, the form and proportions of which adapt it to this peculiar method.

The ore to be reduced is broken up very fine, the pieces not exceeding peas or beans in size, and is mixed with lime or

other flux in such proportion that the gangue contained in the mass shall form a fluid basic slag without taking up much protoxide of iron. When the ore is a hematite, or contains silica, some alumina is added, in the form of aluminous iron ores, and manganese in manganiferous ores.

To avoid the injury to the lining, which has proved a fatal defect in many processes of direct reduction in lined furnaces, Siemens adopts a lining of Bauxite, of which the best consisted of

Alumina.....	53.62
Peroxide iron.....	42.26
Silica.....	4.12
	<hr/>
	100.00

This is mixed and cemented with 3 per cent. of clay and 6 per cent. of graphite. Silicate of soda, which is also used instead of clay, possesses the advantage over plastic clay that it sets at a comparatively low temperature.

The furnace being properly lined and heated, about a ton (1,016 kilogrammes) of prepared ore and flux is charged, and the furnace is revolved slowly. In three-quarters of an hour this charge is well heated, and a quarter of a ton (229 kilogrammes), or rather more, of fine coal is added; and the speed of rotation is then increased. The reactions take place with great rapidity, the ore is fused and reduced, and the flux unites with the siliceous gangue, producing a fluid cinder. The furnace is then again slowly revolved; carbonic oxide issues from the charge, and is consumed by heated air, which is admitted into the furnace only during this period of reaction; the gas from the producer being almost entirely shut off.

When the reduction is complete the machine is stopped, the liquid slag tapped off, and the metal is balled up by again rotating the furnace chamber. If fuel is used in sufficient quantity the product is steel; if the amount of fuel is restricted, iron is produced.

The process occupies about two hours, and the product

is about a half-ton (508 kilogrammes) of metal. Each furnace should yield about five tons (5,080 kilogrammes) per day.

When the furnace is producing iron, and steel is to be made from the product, the sponge is generally removed to a steel-melting furnace and there carbonized. This latter is probably the most satisfactory method. In making steel, one-eighth of a pound of fuel is capable of supplying the heat absorbed by the fusion of each pound of reduced metal.

Thus, allowing no waste, from 700 to 900 pounds of fuel should be sufficient to make a ton of steel. Actually, in consequence of losses by conduction, radiation, and the discharge of hot gases into the atmosphere, the consumption is from 1,400 to 1,600 pounds of fuel.

153. Carburization of Iron, resulting in the production of steel, is practiced in several ways, and many methods have been devised which have not come into general use. The most important of known processes is that of the carburization of wrought iron, usually in the form of bar-iron. Nothing is known of the circumstances of its invention, or of the date and place of its earliest adoption. It was described by Réaumur in 1722 in a special treatise, in which, also, he details experiments which he had himself made.

The affinity of carbon for iron is considerable at a high heat, and acts at even comparatively low temperatures when iron is long imbedded in finely divided carbon.

The process of conversion, called the "*cementation process*," consists in the imbedding of the iron to be converted into steel in powdered charcoal, and its submission to a high temperature, until the penetration of the mass of metal by carbon has taken place, and their union has become so complete as to convert the iron into steel.

In another, the "*crucible process*," which is very extensively practiced, the iron is carburized by fusion with carbon, and such other materials as are considered necessary to give a steel of the required quality.

In Chenot's process, a metallic sponge, produced by reduction of ore without fusion, is saturated with substances

rich in carbon, as resin, tar, or fatty matter, in proper proportion, and is compressed in moulds, which give it the most convenient size and shape. This moulded metal is next fused in crucibles, and the molten metal is cast in ingot moulds. The charges vary from 40 to 60 pounds (1.8 to 2.7 kilogrammes) in weight, and the operation requires from four to five hours. This method was introduced by Chenot about the year 1858, but has not come into general use. The process invented by Chas. Macintosh, in 1825, is an illustration of a class of methods, the introduction of which has been often attempted, but never with full success. The iron is subjected, at a high temperature, to the action of gases containing carbon, or of the vapors of volatile hydrocarbons.

Although the modern process of cementation was introduced, probably, at some time during the 17th century, it is not improbably derived from the rude process still in use among the Hindoos, in the production of "Wootz" steel. In this process, iron, in pieces weighing from five ounces to sometimes two pounds (140 grammes to 0.9 kilogramme), is packed in a crucible with one-tenth its weight of dried chips from the stem of the *Cassia auriculata*, and is covered with green leaves of the *Asclepias gigantea*, or of the *Convolvulus laurifolius*; the crucible is then filled up with clay. When the clay is well dried, the crucibles are heated in a furnace formed by digging a crucible-shaped pit large enough to contain a considerable number of crucibles—usually fifteen. Belows of ox-hide furnish the blast. The crucibles are placed so as to form an arch or dome, and a fire of charcoal is built in its interior. The operation of fusing the metal occupies about four hours, and the product is sometimes a very fine quality of steel.

The crucibles are usually small—about four inches (10 centimetres) high—and the button of steel weighs but a few ounces. The steel is malleable, and is drawn out, by hammering, into bars for the market. The best samples can only be forged at a low red heat, and with great care, as the steel contains too much carbon to work well— $1\frac{1}{2}$ per cent.

or more. It is of low specific gravity—7.2 to 7.6—takes a high temper, and makes good cutting tools.

154. Steel of Cementation.—A very usual method of making steel consists in the carburization of bar iron by heating in charcoal, and subsequently working under the hammer or melting in crucibles. The first step in the process is that of conversion or cementation.

The "converting furnace," Fig. 38, as built by the best steel-makers, is a structure of brick-work inclosing a pair of fire-brick boxes, troughs, chests, or pots, as they are variously termed, in which the bars are placed in a bed of charcoal. Beneath these chests is a fire-place, the flames from which envelop the chests while passing to the chimney. These chests are open, and a fire-brick arch is turned over them. The ends of this arched roof are closed in; but openings are left, through which a workman can enter to fill the chests. Flues from the fire-place are led up between and around the chests, and the flames, after enveloping the latter and filling the arch, pass out on either side, entering low chimneys, whence they issue into a tall, open-topped, pyramidal covering of brick-work, which constitutes the main and external portion of the whole structure.

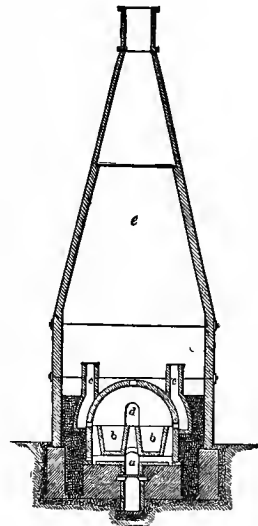

FIG. 38.—CONVERTING FURNACE.

The size of furnace varies somewhat with different makers. The usual size of chest, as adopted by Sheffield makers, is from 8 to 15 feet (2.4 to 4.6 metres) long, and 2 to 3 feet (0.61 to 0.91 metre) wide. The height of the pyramidal stack is usually 30 or 40 feet (9.1 to 12.2 metres); its base has a length of about three times that of the chest, and is twice the width of the pair of chests inclosed. Sometimes two pairs of chests are placed side by side, and the width of base is then about two-thirds its length.

The bars selected for cementation are $\frac{5}{16}$ to $\frac{3}{4}$ -inch (0.8 to 2 centimetres) thick, 3 inches (7.6 centimetres) wide, and of such length that they may be conveniently packed in the converting furnace.

A thin layer of coarsely ground charcoal is spread over the bottom of the chest, and on this the bars are laid with spaces between them, which are filled with ground charcoal, while another layer covers the iron; this last layer is, in turn, made the bed for another set of bars. Alternate layers of iron and coal are thus laid down until the chest is nearly filled, leaving room for a thicker layer of charcoal at the top. The whole is finally covered with fine, dry sand, or clay, or is plastered over with "wheelswarf"—the sand from grindstones. Care is taken to exclude the air very thoroughly.

"Trial bars" are placed where they may be withdrawn, through openings left in the chest, for the purpose of occasionally determining, by their examination, the condition of the steel. These openings are plugged with clay, and the manholes in the heads of the arch are closed by bricks.

The powdered charcoal, used as the "cement," is usually made from hard wood, and is sometimes mixed with a small proportion of salt and of wood-ash. The last-named materials are expected to flux the silica contained in the charcoal, and thus to prevent injury of the steel by the absorption of silicon.

The iron used is very carefully selected, if tool-steel is to be made, and is the purest known in the market. Swedish iron is used almost exclusively by British steel-makers, and largely by makers in the United States. The latter also use a few well-tried brands of iron, which are generally made from Lake Champlain or from Lake Superior ores. For machinery steel and cheaper grades, other less costly and less pure ores and irons are used.

The troughs having been charged and closed up, the fire is started and the furnace is slowly heated up, attaining, in two or three days, a temperature of about 2,000° Fahr. (1,095° Cent.), at, or above, which temperature it is held for several days. Steel for tools requiring a considerable degree of car-

bonization, and made from the heavier sizes of iron, is a week in acquiring the necessary temperature, is retained a week or ten days at maximum heat, and occupies nearly a week cooling down; thus, three weeks' time is needed to convert each charge. Each furnace makes sixteen charges per annum. With thinner metal, and a lower degree of carbonization, less time is required; a week of maximum heat answers for shear steel, and four or five days for spring steel.

During the latter portion of this period, the trial bars are occasionally examined, and the gradual change of texture, which indicates the gradual introduction of the carbon as it penetrates the metal, is observed. When the carburization has become satisfactorily complete, the furnace is cooled down and the steel removed.

The bars are then found to have become somewhat increased in dimensions, with a corresponding decrease of density, and are seen to be "blistered" in many places, by the bursting off of a pellicle of surface metal where the carbon oxides have forced their way out. The metal has become hard and elastic, with the granular fracture and all the characteristics of steel. The proportion of carbon is a maximum at the surface, and regularly decreases toward the centre of the bar, the carbon necessarily penetrating the metal, under a gradual decrease in "head," by a slowly progressing flow from the surface. The texture is usually irregular and crystalline, the color white; the grain is finest toward the centre and coarsest toward the surface.

Case-hardening is a modification of this process, in which cementation is only carried so far as to give a steely character to a thin surface layer.

The "cement" used contains less carbon, and often consists largely of nitrogenous matter and hydrocarbons, such as are found in scraps of leather. A common mixture consists of about ninety per cent. carbon, and ten per cent. of carbonate of lime or of potash. The prussiate of potash—potassium ferrocyanide—is often added.

Blister steel, which is the product of conversion by the usual method, is, in consequence of its irregular constitution,

and structure, unfit for general use, although sometimes made into cheap grades of tools. It is largely used only for conversion into "shear steel" when containing so little carbon as to weld readily, and into cast steel when containing too much carbon to permit welding. From one to two parts of fuel are consumed, according to degree of carbonization, per part of steel made.

Shear steel is made from blister steel by shearing the bars into short lengths, piling, reheating, and drawing down at a good welding heat, using a flux to insure thorough union into a sound bar.

A common method consists in piling five bars of blister steel, of which one is longer than the others, and serves as a handle by which the mass is manipulated under a tilt-hammer. The bundle is secured by wrapping with wire; the flux is clean sand. As soon as the pile is compacted sufficiently by a few blows of the hammer, the binding wire is knocked off, and the pile is reheated and drawn down to the desired finished size. This process of piling and drawing down greatly improves the metal; the bar of tilted steel is much superior in strength, ductility, and homogeneity, to the blister steel from which it is made. A repetition of this process gives "double shear" steel, and still further improves it. Double shear steel is used for cheap edge tools and some other instruments, but cannot be used for fine work.

The hammer used for tilting the steel is light and quick working, making 300 or 400 blows per minute, and capable of regulation by the workman.

Tilted steel is usually considered better than rolled; the hammer is almost invariably used in working shear steel.

155. "Cast Steel" is produced whenever fused steel is cast into ingots, or other forms, for the market. It is made by all methods which involve fusion, either in the operation of steel-making or subsequently. The tool steels and other fine grades are all cast steels.

The finest cast steels in the market are usually produced either by melting in crucibles and casting blister steels, or by

fusing together, in crucibles, wrought iron, carbon, and flux, and casting in ingots after thorough fusion.

The products of these methods are both known as "crucible steel," and constitute the greater part of all steel used for cutlery, fine tools, and every kind of work for which metal of the greatest possible purity and uniformity of composition and character is demanded.

In some few cases, these steels have now been displaced by the product of the Siemens and the Bessemer processes, which latter have the advantage of greater cheapness.

156. Crucible Cast Steel, as made by melting blister or cemented steel to give it a homogeneous character, is the standard steel for fine tools. This process was introduced in Great Britain, and was probably invented, by Benjamin Huntsman, about the year 1770. He was then living near Sheffield.

The "crucibles" or pots (Figs. 39, 40, 41) in which steel is melted, as used at Sheffield and by many American makers, are composed of a fine and very refractory clay. They are about 16 inches (40 centimetres) high, 7 or 8 inches (17 to 20 centimetres) in greatest diameter, and weigh about 25 pounds (11.3 kilogrammes). To make each pot, 20 or 22 pounds (9.1

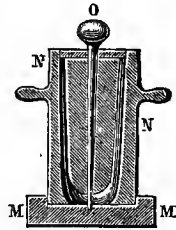

FIG. 39.



FIG. 40.



FIG. 41.

to 9.9 kilogrammes) of new clay, 1 or 2 pounds ($\frac{1}{2}$ to 1 kilogramme) of cinder, and 2 or 3 pounds (1 to 1.3 kilogrammes) of old pot material are ground together very thoroughly, and 5 or 10 per cent. of ground coke-dust is often added. The material is mixed and kneaded by treading under foot on the "treading floor" 8 or 10 hours, and is then ready for use. The pots are then formed by hand, and are allowed to dry a week or more before "annealing" them by slowly and steadily raising them to a bright red heat, and as slowly and steadily cooling them.

In the United States, crucibles are very extensively used in which the clay is mixed with a considerable proportion of graphite. These pots wear better than those of clay. They yield some carbon to the metal, and this is compensated by a corresponding reduction of the charge of carbon introduced. These crucibles are often larger than those first described, and carry from 40 to 70, or even 80 pounds (18 to 36 kilogrammes) of steel.

Steel-melting furnaces (Fig. 42) are usually plain fire-brick structures with rectangular chambers, each of a size sufficient

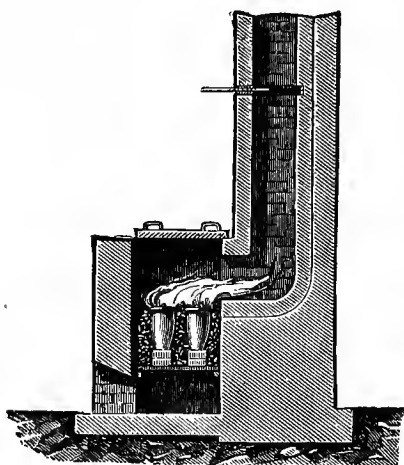

FIG. 42.—CRUCIBLE FURNACE.

to permit the introduction of two crucibles. These chambers are arranged side by side before a common flue, and with their tops level with the floor. The ash pits are reached from a trench or "cave," extending along the front of the row. A high chimney gives the sharp draught which is essential to secure the intense heat demanded in steel melting. Coke is the usual fuel.

The crucible is charged with the proper weight of metal and carbon as required, together with a small percentage of spiegeleisen or other manganese-bearing materials after they are placed in the furnace.

The use of manganese was first practiced by Josiah M. Heath, who patented the process in 1839; but it is probable that manufacturers sometimes used fluxes containing manganese at an earlier date, without, however, knowing the reason of their efficiency.

The precise action of manganese is not fully determined. Without it, only the purest known irons could be used in making steel, and even those were not usually capable of

being converted into a thoroughly malleable product. By the addition of a small quantity of manganese, which rarely exceeds in amount, in the cast steel as finally produced, one eighth of one per cent., the metal becomes easy to work, and in every way improved. It acts as a corrective of red shortness and an "antidote" to sulphur; but this action takes place, however, without removal of the sulphur. Its effect is to produce hardness without great brittleness, while giving the steel greater malleability at high heats. Manganese also assists by reducing liability to the formation of blow holes in the ingot by absorption of oxygen.

The pots are set in the furnace upon stands made of clay, which sustain them clear of the grate bars. They are charged with the broken blister steel and manganese, and sometimes with a flux of broken bottle-glass, are carefully covered with a lid of crucible clay, and allowed to remain at a temperature exceeding, probably, 3,600° Fahr. (about 2,000 Cent.) an hour or an hour and a half, the furnace being, meantime, kept well supplied with fuel and at the highest temperature possible.

When the steel, at the end of this time, is found to be thoroughly melted, it is "teemed," *i. e.*, poured off. The "puller out," protecting his clothing and person by coarse bagging or cloth saturated with water, stands directly on the top of the furnace and raises the crucible from its bed with a pair of large tongs fitted with handles 4 feet (1.2 metres) or more in length, and swings it out into the "teeming hole," as it is called, a square, iron-lined hole in the floor, large enough and deep enough to take it in.

The melter next takes the pot in the "teeming tongs," and pours the molten metal into the ingot mould, a helper standing by with a "flux stick," to prevent the escape of flux with the steel.

The ingot has either an octagonal section or a section like a square with the corners removed; it tapers slightly from end to end. The mould is in two halves, and is coated within with a preparation containing soot or other form of carbon. The ingot, when removed from the mould, is "topped," *i. e.*, a small piece is knocked from the upper end

with a heavy hammer or sledge, and inspected by an experienced judge of the metal, who assort the several qualities into standard lots, each of which is of a definite "temper." With care and skill, differences of less than one tenth of one per cent. carbon are noted, and, in some cases, selected tool steels of high grades have been distinguished by the eye when differing one twentieth of one per cent. in proportion of carbon.

The ingots are finally hammered and rolled into forms suitable for the market.

The "*mixture*" introduced into the crucible has a composition which is determined by the character of the available materials and of the product demanded.

It usually consists of either blister steel produced by the cementation process, with a small percentage of carburet, or of peroxide, or of other compounds of manganese, with some suitable flux; or it is chiefly selected iron of fine quality, with a definite proportion of charcoal and of manganese and flux.

Chromium, titanium, tungsten, and other elements, are sometimes introduced, as in the production of chrome steel or of titanium or tungsten steels, so called.

The principal properties of the crucible steels and of carbon steels generally will be discussed in a later chapter. In structure they are usually very uniform and homogeneous, granular, compact and dense, and are generally found better fitted for purposes demanding fine quality than are other kinds of steel. Although each crucible contains but a small quantity of metal, immensely large castings are made by fusing the metal all at one time in a large number of crucibles, which are systematically emptied into a common reservoir or mould. Castings weighing many tons are sometimes thus made.

Crucible steels are principally used for cutlery and other tools; but they are sometimes made with so low a proportion of carbon as to be properly denominated "homogeneous iron," and are then used for boiler-plates, axles, lining tubes for ordnance, and for parts of machinery in which homo-

geneousness, ductility and strength are desired in combination.

Wootz, or Indian steel, is made by the second of these crucible processes, as already described.

Cast steels owe their excellence to the care taken in the selection of the raw material used, to the extraordinary skill acquired in assorting it, and to the great uniformity of quality and texture insured by fusion. The harder kinds of cast steel made from cement steel require the addition of carbon in the crucible when the process of cementation is interrupted before the degree of carburization demanded for the cast steel is fully attained.

As steel in fusion absorbs oxygen freely, the exclusion of the air from the melting pot is important. The higher the temperature, and the less the proportion of carbon, the more freely is gas absorbed. The crucibles, when of purest clay, can only be used a few times. Those of mixed clay and graphite are more durable. In pouring, the temperature should be as low as possible, without incurring danger of premature solidification. The moulds should be warmed before they are used, should be kept hot until filled, and should then be promptly and carefully covered.

Puddled steel is often remelted for large castings. The hardness, the lack of ductility, and the diminished welding power of the steels make it necessary to observe greater precaution in working them than in the working of iron, and their susceptibility to injury by prolonged high temperature compels greater care in heating them. The ingots are worked at from a moderately high red heat to a low yellow heat; at too high a temperature they burn, scintillate, and lose carbon; at too low temperatures they crack, and refuse to weld.

157. "Open Hearth Cast Steel" is produced by melting in large quantities on the hearth of a reverberatory furnace. The class includes steels produced by the Siemens-Martin process, to be described later. The Siemens furnace is used as a melting furnace for steel, both when melting in crucibles, and when melting on the hearth in masses of four

or five tons (4,064 to 5,080 kilogrammes). This latter is the most practicable method of producing large ingots and castings. By the old method the melting of a ton (1,016 kilogrammes) of steel requires often three to four tons (3,048 to 4,068 kilogrammes) of coke; by the Siemens furnace the work is done readily with a ton (1,016 kilogrammes) or less of the cheapest fuel, the breakage of crucibles is greatly reduced, and the lining of the furnace is better preserved.

Steel, melted on the Siemens open hearth, requires the consumption of three-quarters of a ton (762 kilogrammes) or less of fuel per ton of metal, and the rapidity of melting is very much greater than in pots.

The high temperature required for steel melting has precluded the use, to any considerable extent, of the ordinary form of reverberatory furnace, and the Siemens furnace is the only one which has, up to the present time, been adopted for this work with satisfactory and general success.

Steel making on the open hearth of the Siemens furnace, as proposed by C. W. Siemens, was first practiced in France with commercial success, by the Messrs. Martin, in 1865. The process is generally known as the *Siemens-Martin process*.

This method is sometimes regarded as one of decarburization of cast iron by the addition of uncarburized metal; it is perhaps more correctly a method of imparting a definite proportion of carbon to wrought iron by mixture, in fusion, with cast iron. It is extensively practiced, and is the principal, and, practically, as yet, the only competitor with the pneumatic process in the production of soft and low grade steels. It may be used for the production of tool-steels, but it is seldom so applied.

For this process the bed of the reverberatory furnace is given a form somewhat resembling that of the puddling furnace, and the lining, or bed, is made of selected clean silicious sand, containing some alumina or magnesia. Bauxite, containing 65 per cent. alumina, 15 per cent. silex, 5 per cent. iron-oxide, and some water in combination, makes a good lining also, so long as it can be retained in place.

A charge of scrap iron, or old rail-ends, either iron or

steel, is introduced after the furnace has been brought up to a full white heat, and to this is added the required amount of cast iron. The weight of a charge is from 8 or 10 to 60 or more tons (8,064 to 60,960 kilogrammes). The following represents a fair charge in the old process:

	Pounds.	Kilogrammes.
Pig metal; No. 3, or white iron.....	50,000	22,720
Wrought-iron scrap, or puddle bar.....	45,000	20,430
Spiegeleisen.....	5,000	2,270
	<hr/>	<hr/>
	100,000	45,420

With a 40-ton furnace, a product of 7,000 tons or more, annually, has been obtained.

As practiced in some French establishments, the following are the details of the process as given by Kohn :

The pig and scrap iron and steel are heated separately before charging into the steel furnace. A charge of about 2,000 pounds (900 kilogrammes) of the heated pig metal is first placed on the hearth and melted down. The scrap steel, and wrought iron, heated to a white heat, are next added in charges of 440 pounds (about 200 kilogrammes) at intervals of a half hour, each charge being melted down and thoroughly incorporated in the bath before the next is added.

Recarburization becomes complete in six or seven hours, and the mass becomes pasty, as in puddling, after the fusion of 4,840 to 5,280 pounds (2,200 to 2,400 kilogrammes) of wrought iron.

Recarburization is then effected to the customary extent by the addition of cast iron, in, usually, four charges of 440 pounds (200 kilogrammes) each, this metal being similar to that first charged, and generally containing some manganese.

The bath is covered with a slag of blast-furnace cinder, rendered more silicious by the addition of sand, and the metal is kept fused any desired length of time while adjusting its quality. The total weight of metal charged, as above, is usually about 8,800 pounds (4,000 kilogrammes), and the product is not far from 8,140 pounds (3,700 kilogrammes). The exact proportions will vary with the composition of

the materials used, and with the character of product demanded.

The charge is melted down under an oxidizing flame, and the carbon is thus partly removed by burning out, and the exact proportion required is then secured by dilution with malleable metal. The molten cast metal forms a liquid bath on the hearth, into which the wrought iron gradually dissolves. The metals having been thoroughly fused, the process is continued until samples taken from the furnace and tested exhibit the desired quality, or until they indicate complete decarburization. In the latter case, the spiegeleisen, or other manganese-bearing material is added, and tests of samples are again taken to determine quality.

If the metal is not now of precisely the quality wanted, the addition of cast iron or spiegeleisen, or of wrought iron, is continued, as required, until the steel is found to be of the exact character demanded; and it is then tapped off into ingot moulds.

The cast iron should be carefully selected, and especially free from phosphorus when steel containing considerable carbon is to be made. The wrought iron should be selected with similar care, when fine steels are to be produced, and the spiegeleisen should always be very free from either phosphorus or sulphur; it usually contains ten per cent. or more of metallic manganese. The softer the grade of steel made, the richer should the spiegeleisen be made in manganese, and the lower its proportion of carbon.

For steels containing a very small proportion of carbon, a comparatively high percentage of phosphorus, or other hardening element, is admissible.

The cost of the steel will vary greatly with the cost of scrap metal and of cast iron, but is usually, in gross, not far from that of making steel by the pneumatic process.

Each furnace requires three furnace-men, and outside labor to handle the product. The cost of repairs varies greatly with the management. It should be a small item. The total cost of steel per ton (1,016 kilogrammes) should not exceed the value of ten days' laborers' work.

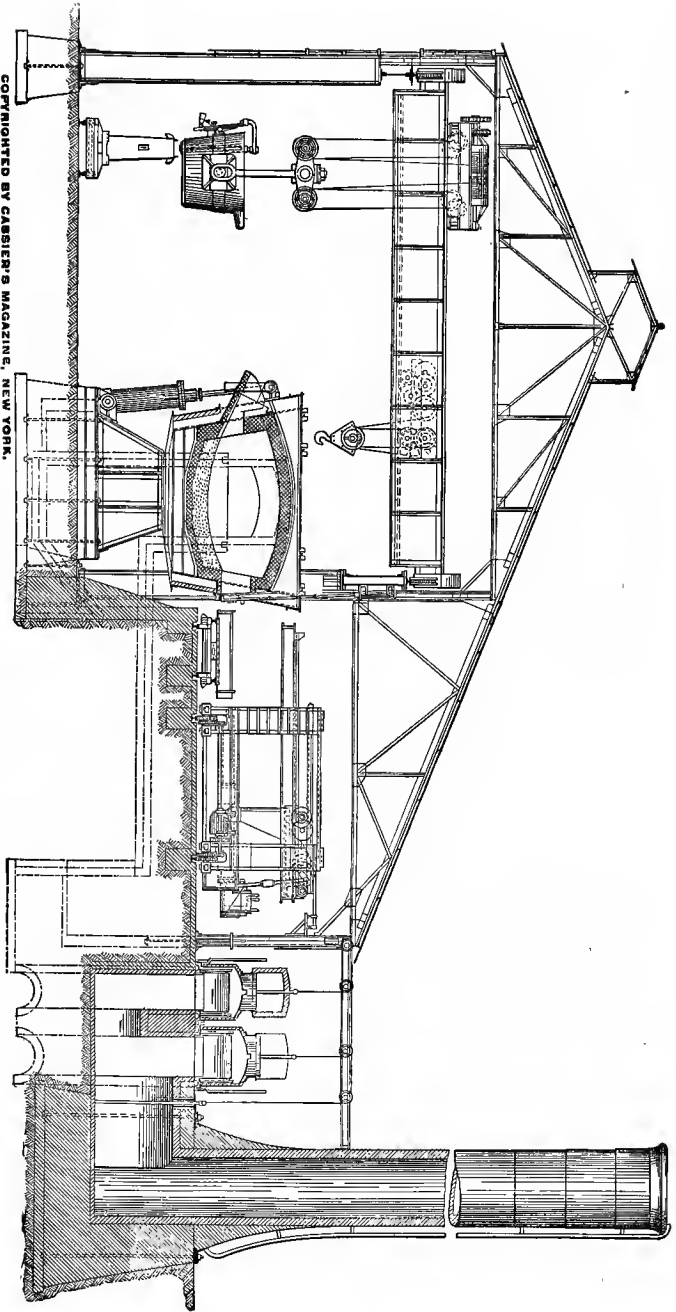

COPYRIGHTED BY CASBIER'S MAGAZINE, NEW YORK.

OPEN-HEARTH "PLANT."

This process possesses some peculiar and important advantages. The steel lying on the open hearth, under a flame which may be made oxidizing, deoxidizing, or neutral at pleasure, may be sampled at convenience, retained in fusion any desired length of time, and treated in any way that may be necessary in the modification of its quality.

The plant is simple, inexpensive, and can be, from time to time, enlarged, as may be considered expedient, without limit. The range of quality of material available for use is less restricted than in some other processes, and in making "mild steels"—"ingot irons"—as little as 0.10 per cent. carbon can easily be reached.

158. The "Direct Process" of steel making, as practiced by Siemens, is similar to that already described as producing malleable iron, except that the final step in the process is the addition of spiegeleisen, in the manner described above, to recarburize the iron to the desired degree.

After the addition of this spiegeleisen, the metal is sampled and tested, and, if found of proper quality, is tapped off. If it requires an additional dose of carbon or manganese, more pig-metal or more spiegeleisen is added, and, if the carbon or the manganese is in excess, the bath is modified by addition of scrap iron, or of ore, and by exposure to the oxidizing flame. When found to be precisely of the character demanded, the steel is tapped off into ingot moulds, and finally sent to the rolling mill, or shaped under the hammer.

The process above described is, in greater detail, as given by its inventor, as follows :

In the Bessemer process, carbon, silicon, and manganese appear to be eliminated uniformly. In the open-hearth process, the degree and the time of elimination are quite different. During the time the charge is passing into the fluid state, carbon, silicon, and manganese are all more or less oxidized, leaving usually about 50 per cent. of the total amount contained in the charge, this quantity varying slightly with the temperature of the furnace. As soon as the whole of the charge is fluid, the carbon remains almost, if not entirely, unchanged, until the whole of the silicon and manganese are oxidized, which process

takes from three to four hours. During the time occupied in the oxidation of the silicon and the manganese—no gas being given off—the metal in the bath remains tranquil. When the silicon is reduced to about 0.02 per cent., and the manganese has disappeared entirely, the oxidation of the carbon commences, and the evolution of carbonic oxide throws the metal into violent ebullition; it is described by the melters as “being on the boil.” This ebullition continues more or less until the carbon is reduced to 0.10 per cent. or under, when the metal becomes perfectly quiet, and the slag, which half an hour previously had been of a brownish tinge, begins to blacken from a slight oxidation of the metal. From a number of analyses made to determine the oxidation of carbon, silicon, and manganese, during the different periods of the process, two have been selected. No. 1 was an ordinary pig and ore charge with about 25 per cent. of scrap. No. 2 was a similar charge, as far as composition was concerned; but after the pig and scrap were melted, sufficient spiegeleisen was added to give by calculation 1.5 per cent. manganese. Samples of the metal in each case were taken every half hour and carefully analyzed, with the following results:

TABLE XXXVI.
CHANGES IN THE SIEMENS PROCESS.

NO. 1.

NO.	CARBON. Per cent.	SILICON. Per cent.
1	1.00	1.281
2	1.00	1.118
3	1.00	.508
4	1.00	.326
5	1.00	.232
6	1.00	.046
7	1.00	.020 on the boil.
8	.80
9	.55
10	.44
11	.25
12	.18
13	.10
14	.06

NO. 2.

NO.	CARBON.	SILICON.	MANGANESE.
	Per cent.	Per cent.	Per cent.
1	1.34	1.60	1.40
2	1.34	.910	.792
3	1.34	.260	.100
4	1.34	.140
5	1.34	.080
6	1.34	.023
7	1.34
8	1.34
9	1.10
10	1.00
11	.90
12	.68
13	.50

When pure iron is used, no appreciable alteration takes place in the percentage of phosphorus contained in the pig and scrap, but it is necessary to employ only the purest. Several experiments were made at one time on a series of charges at Landore, from the same cargo of pig iron—a No. 1 hematite—and ores from various districts, no scrap being used in any of the charges, and the following results were obtained, showing the retention of sulphur.

NAME OF ORE USED.	SULPHUR IN PIG IRON.	SULPHUR IN FINISHED STEEL.
	Per cent.	Per cent.
Elba	0.025	0.032
Marbella.....	0.025	0.064
Sommoostro.....	0.025	0.025
Mokta.....	0.025	0.025
Tagus.....	0.025	0.064
Soumah	0.025	0.048

To insure that the iron was homogeneous, samples were taken in each case when the metal was melted, and it was found uniform throughout. The whole of these charges were manufactured into plates, which had a breaking strain of from 25 to 29 tons per square inch (45.5 to 45.6 kilogrammes per square millimetre), and elongated from 25 to 30 per cent. in 8 inches.

The pig iron most suitable for the open-hearth process—the sulphur and phosphorus being low—is that containing the least carbon and silicon. In the first place, it contains a higher percentage of iron, and, in the second, it does not require to be so long in the melting furnace before the metal is completely decarbonized. Moreover, pig iron containing a large percentage of silicon, although it is all oxidized, invariably yields inferior steel. More than 0.50 per cent. of manganese is objectionable, not only on account of the delay it causes, but because of the destruction of the silica bottom by the formation of a fusible silicate of manganese. From long experience, it has been found that steels from different brands of hematite pig iron, chemically the same and made from the same ores, not only act differently in the furnace, taking more time, cutting the bottom, etc., but in their finished state show a marked difference in their tensile and other tests. When first noticed, this was attributed to some defect in the mode of analysis, which failed to detect minute traces of elements possibly derived from the coke or limestone used in their manufacture; but it was found that two cargoes of pig iron, of different brands, both of which worked in a most unsatisfactory manner by themselves, gave, when mixed in equal proportions, results which were everything that could be desired. Others invariably gave good results *per se*, and by mixing as many brands as possible uniform results may be obtained.

Experiments made at Landore show that no metal added to the bath of steel has the slightest effect, so far as the elimination of sulphur is concerned, and manganese is the only metal that will counteract it. Manganese is indispensable in steel made by an oxidizing process. An ingot from a charge composed of Swedish pig iron and puddled bar made from the best hematite pig containing no manganese, will break into pieces at the first blow of a hammer, whilst a similar ingot containing 0.08 per cent. manganese will forge. Tungsten, alloyed with steel in small amount appears to harden it without detracting from its toughness.

159. The Fluxing of the Steel, more especially with a view to the removal of phosphorus, when that element is present in objectionable quantity, is a subject which has attracted much attention from metallurgists.

Henderson's process, applied to steel making, is an example of such an effort. In this process, fluxing is effected by the use of the fluorides and oxides, fluor-spar and iron oxide, as in the puddling process introduced by the same metallurgist. These materials are usually applied as a fettling on the bottom and the sides of the furnace, but may be injected in a finely divided state into the bath of molten metal. Oxide of manganese is added with oxide of iron; and any lime present, or added in the process, assists in the formation of cinder.

Making spring steel, the following figures are given : *

Cast iron is taken as containing 3 per cent. carbon, 1 per cent. silicon, $\frac{1}{2}$ per cent. manganese, and 0.12 per cent. phosphorus; 75 pounds (34 kilogrammes) of fluor-spar are used per ton (1,016 kilogrammes) of steel made. We then have, as an estimate :

Fluor-spar, 75 lbs. (34 kilogrammes), @ \$13.00 per ton.....	\$0.48
Ore, hematite, 356 lbs. (162 kilogrammes), @ \$12.00 per ton.	1.91
Labor.....	.29
Coal.....	.14
Waste.....	1.00
	3.82

which is the cost, exclusive of cost of pig iron. From this is deducted the value of the slags produced, which may be sent to the blast furnace.

Iron containing 1 per cent. phosphorus may require :

150 lbs. (68.2 kilogrammes) spar, @ \$13.00 per ton.....	\$0.96
450 lbs. (203 kilogrammes) ore, @ \$12.00 per ton.....	2.70
Labor.....	.29
Coal.....	.14
Waste.....	1.00
	5.09

The slags and the recovered phosphorus are assumed by the inventor of this method to have value. It is stated that this process results in the elimination, to a very complete degree, of the sulphur and the silicon as well as the phosphorus.

The open-hearth process of steel making by either of the above methods will occupy six or seven hours to each charge, usually, and it is often customary to undertake but one heat at each twelve-hour shift.

Mr. Martin advises for mixtures usually, 1000 parts of wrought iron, and about 800 parts dark cast iron, when hard steels are to be made, and 700 parts cast iron when making soft steels; the proportions varying somewhat, however, with the character of the iron used. The loss is not far from 6 per cent. of the weight of iron charged, and the weight of fuel is 25 or 30 per cent. more than that of steel made.

The Talbot Continuous Open-Hearth Process employs a tilting furnace which may be operated at a capacity of from 20 tons upward; 100 to 150 or even 200 tons is asserted to be entirely practicable. The charge is run in from the cupola, blast furnace or mixer, desiliconized wholly and decarbonized largely by a blanket of slag rich in oxides, and reduced ultimately in the usual way. The charge is run off and its place supplied by a new charge; the bottom being at no time allowed to become exposed. The time required with twenty-ton charges is about 3 hours and 40 minutes.* Thirty charges a week may be worked.

Scrap-iron used is introduced at the blast furnace or the cupola. The Wellman furnace permits the steel to be tapped off at one side and the slag at the opposite side. A basic lining is preferred. With more than 20 per cent. iron in the slag, the carbon and phosphorus are eliminated together and freely; when falling to 12 per cent. the carbon passes out less rapidly than the phosphorus. About 105 or 110 tons of steel are obtained for each 100 tons of iron charged. Tapping and charging small quantities makes the process continuous.

Dr. Miller gives the following as the composition of the pig iron and of the steel made from it by this method:

* Proceedings Iron and Steel Institute, 1900.

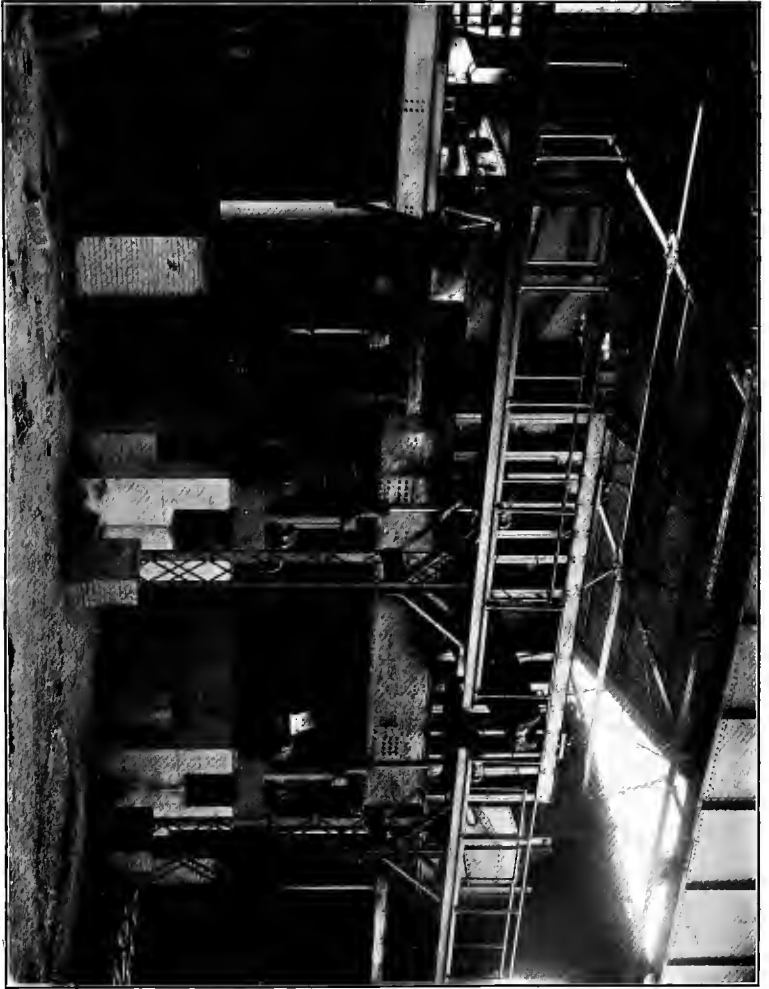

WELLMAN'S "LIFTING FURNACE."

[To face page 210.]

ELEMENTS.	PIG IRON.	CRUDE STEEL.	STEEL-IRON.
Carbon	2.83	1.8	0.99
Silicon	2.95	0.27	0.15
Sulphur	0.11	0.02	trace
Phosphorus.....	1.46	0.30	0.29
Arsenic.....	0.04	0.04	0.02
Manganese	0.32	0.09	0.09
Calcium.....	0.32	0.31
Sodium.....	0.14	trace
Iron	92.29	97.03	98.14

The principal peculiarity of this process is the very great reduction of the proportion of silicon and the removal of a considerable proportion of sulphur and phosphorus.

The character of the steels made by the above described methods is very variable, and depends upon the character of the materials found available, and upon the skill with which the work is done. The steels thus made, and especially those produced by the open-hearth process in general use, are generally "low" steels, such as are best adapted to those purposes for which iron was formerly exclusively used, and should be classed as "ingot" iron, rather than as ingot steel.

The Siemens-Martin process is peculiarly well adapted to making fine grades of such metal. It is more or less economical than the Bessemer process, according to the value of the scrap wrought iron, although the continually increasing production of the standard plant in the latter branch of manufacture is making it more difficult to compete when extreme exactness in securing the specified grade is not demanded.

160. The Pneumatic Method of Steel Making, generally known as the Bessemer Process, is the most extensively practiced and the most productive, by far, of all known methods of making ingot metal.

It has been known since the time of Cort that the agitation of molten cast iron, in presence of oxygen, will produce combustion and removal of carbon, and the reduction of the cast iron to the state of malleable iron or of steel.

The pneumatic process secures such an agitation, and a

very thorough intermixture of the fluid iron with the oxidizing atmosphere, by causing the latter to stream up through the molten mass in innumerable minute bubbles; the rapid combustion thus secured is sufficient to supply all heat needed, not only to retain the metal in a fused condition, but, also, so rapidly and so greatly to elevate its temperature during the operation, that the product, even when entirely deprived of carbon, remains a perfectly fluid wrought iron in the converting vessel.

The process was invented independently by Henry Bessemer, in Great Britain, and by William Kelley, in the United States. Patents were issued to both by the U. S. Patent Office, and their interests were combined when the manufacture was established. Bessemer's patent dates from November, 1856, and Kelley's from January, 1857, the latter having been granted after a declaration of interference. Kelley at first forced air under high pressure downward into the mass of molten metal in comparatively few and large streams; Bessemer began in a somewhat similar way, treating steel in crucibles. In both cases, the metal was converted so slowly that chilling took place before the work was completed. When the same operation was conducted in the more effective method now familiar to engineers, it became at once a practically useful process. Since the date of the early patents, this manufacture has grown to enormous proportions. It is the source of the greater part of the "steel" rails now used; it furnishes a large amount of "steel boiler-plates," and is supplying some tool steel. Its product, and the "mild steels" resembling Bessemer metal, which are made by the open-hearth processes, seem likely ultimately to take the place of iron made by the older processes in all forms of construction. The quality of the product may be graded without difficulty from the lowest to the highest percentages of carbon, and can thus be given any desired tenacity, hardness, or ductility. This fact, and its freedom from fibre or cinder-streaks, and from other physical defects, give it manifest advantages, to which are to be added its cheapness and availability in all desired shapes.

The quality of the metal is primarily dependent upon the purity of the ores used in the manufacture of the pig-iron, from which the product is obtained. As no phosphorus is usually removed from the iron, only the best of known ores, containing one-tenth per cent. or less of this element, are generally used in the manufacture of "Bessemer Pig." The ores of the Lake Superior, of the Lake Champlain, and of the Iron Mountain districts of the United States, of Cumberland, in Great Britain, of Bilbao, in Spain, and the rich and pure ores of Algeria, are those most used by American and British makers; while Germany and Austria draw their supplies from the best ores to be found in their mountainous districts. France obtains ores from Algeria, and Sweden possesses fine qualities of native ore. Analyses of such ores have already been given (Arts. 44, 45, 46). To be of value in making pig-iron to be used in this process, the ore must be very free from phosphorus; and the pig-iron should be rich in silicon, as it is upon the oxidation of silicon that the steel-maker relies greatly to secure the high temperature which must be attained during the "blow."

The following table gives the composition of three samples of spiegeleisen, such as finds a ready sale among steel makers:

TABLE XXXVII.
COMPOSITION OF SPIEGELEISEN.

	A.	B.	C.
Iron	85.570	84.455	84.122
Manganese.....	9.142	10.625	10.568
Copper	0.032	0.034	0.036
Cobalt and Nickel.....	0.005	0.005	0.004
Silicon.....	0.068	0.368	0.286
Carbon	5.048	4.304	4.907
Sulphur.....	0.002
Phosphorus.....	0.037	0.044	0.014
Aluminum	0.082	0.045	0.032
Calcium	0.015	0.016	0.021

The spiegeleisen used in this process as a recarburizer is principally of European make, although the franklinite of

New Jersey supplies a part to the American market ; it should be pure and rich, and should contain considerable carbon, especially when used in making the harder grades of ingot metal.

Where the product is intended to be a soft ingot-iron, if spiegeleisen is used, it is difficult to secure sound ingots without the introduction of too large a proportion of carbon, as the needed proportion of manganese carries with it an excess of carbon. In such cases, mechanical compression of the ingot, or the substituting of another alloy, must be resorted to.

An alloy of iron and manganese, known as "ferro-manganese," is made for this special purpose ; it contains from 25 or 35 per cent., or even more metallic manganese. An ore, from which it is sometimes made, has the composition :

Silica	28.6	Lime.....	2.4
Alumina	8.1	Magnesia.....	0.3
Peroxide iron.....	19.4	Water	3.4
Peroxide manganese.....	37.2	Loss.....	0.6
Total			<u>100.0</u>

The franklinite variety of spiegeleisen or of ferromanganese is obtained, in the United States, from an ore containing about

Peroxide iron	68.88	Silica	1.40
Peroxide manganese....	18.17	Alumina.....	0.73
Oxide zinc	10.81	Loss	0.01
Total.....			<u>100.00</u>

in which exists 48 per cent. metallic iron, and 13 per cent. metallic manganese. The zinc is volatilized during the process of smelting.

Another ore used in the United States contains :

Peroxide of manganese.....	79.50
Peroxide of iron.....	6.50
Water ..	3.50
Phosphate of lime.....	trace
Gangue.....	<u>10.50</u>
Total.....	100.00

Containing 50.5 per cent. metallic manganese.

The cast manganese obtained was as follows:

Manganese.....	96.90
Iron	1.05
Aluminum.....	0.10
Calcium	0.05
Phosphorus.....	0.05
Sulphur.....	0.05
Silicon.....	0.85
Carbon.....	0.95
Total.....	100.00

This cast manganese, when refined, had the following composition:

Manganese.....	99.910
Iron.....	0.050
Silicon.....	0.015
Carbon.....	0.025
Other substances.....	traces
Total.....	100.000

The Theory of the Pneumatic Process is as simple as are the operations themselves; nevertheless, great care, skill, and judgment are demanded in working it. When air is forced in small streams into the lower portion of a vessel filled with molten cast iron, it ascends rapidly through the mass and becomes further broken up into minute bubbles, setting the liquid metal into rapid circulation, and breaking up its currents into eddies; the air thus comes into contact with every portion of the iron, and attacks all combustible elements in the order of their affinity for oxygen at that high temperature. These elements are principally silicon, carbon, and iron, the sulphur passing off with the other elements to but slight extent, and the phosphorus usually remaining unacted on. The first element to become oxidized is the silicon, of which the pig-iron charged usually carries between 2 and 3 per cent.; when this has been nearly all burned out, and, in the form of liquid silica, floats as a slag upon the upper surface of the mass of molten iron, the carbon is attacked and passes off with other gaseous products. Finally, when the

oxygen can find so little of the more readily oxidized elements that its affinities still remain unsatisfied, oxidation of the iron itself begins, and the process should be interrupted. There now remains in the vessel a liquid mass of decarbonized and nearly pure iron, in which but very minute quantities of either carbon or silica are to be found, and which may contain a small amount of iron oxide, if the process has been carried too far.

The next step is a recarbonizing operation, by which the desired amount of carbon is added to give the steely quality called for, of manganese to secure the most perfect soundness of ingot, and of silicon to aid in obtaining soundness and to give good welding qualities. Were manganese not added, and were the ingot solidified without compression, the product would be found, especially if containing little carbon, full of "blow-holes," or cells containing air and gas. On analysis this gas is found to consist principally of nitrogen and hydrogen, and the surfaces of the cells exhibit some oxidation. The gas, when analyzed, had the composition, in one example :

Oxygen.....	2.14		Hydrogen.....	56.42
Carbon monoxide.....	2.08		Nitrogen.....	39.36
Total.....				<u>100.00</u>

Manganese having a strong affinity for oxygen, withdraws it from the iron, and thus prevents injury by the production of oxide.

161. The Plant and Apparatus standard in the United States may be taken as illustrative of a highly efficient arrangement. It owes its excellence largely to the skill and intelligence of the men who have developed it in this country, and principally to Mr. A. L. Holley, who designed the works and nearly all peculiar details observable either in arrangement of plant or form of apparatus.

It usually consists of a pair of "5-ton converters," with accessory apparatus. A pair of such converting vessels was originally expected to make about 80 tons (81,280 kilogrammes) per day, or 25,000 tons (25,480,000 kilogrammes)

[To face page 246.]

**BESSEMER STEEL-WORKS,
JOHNSTOWN, PA.**

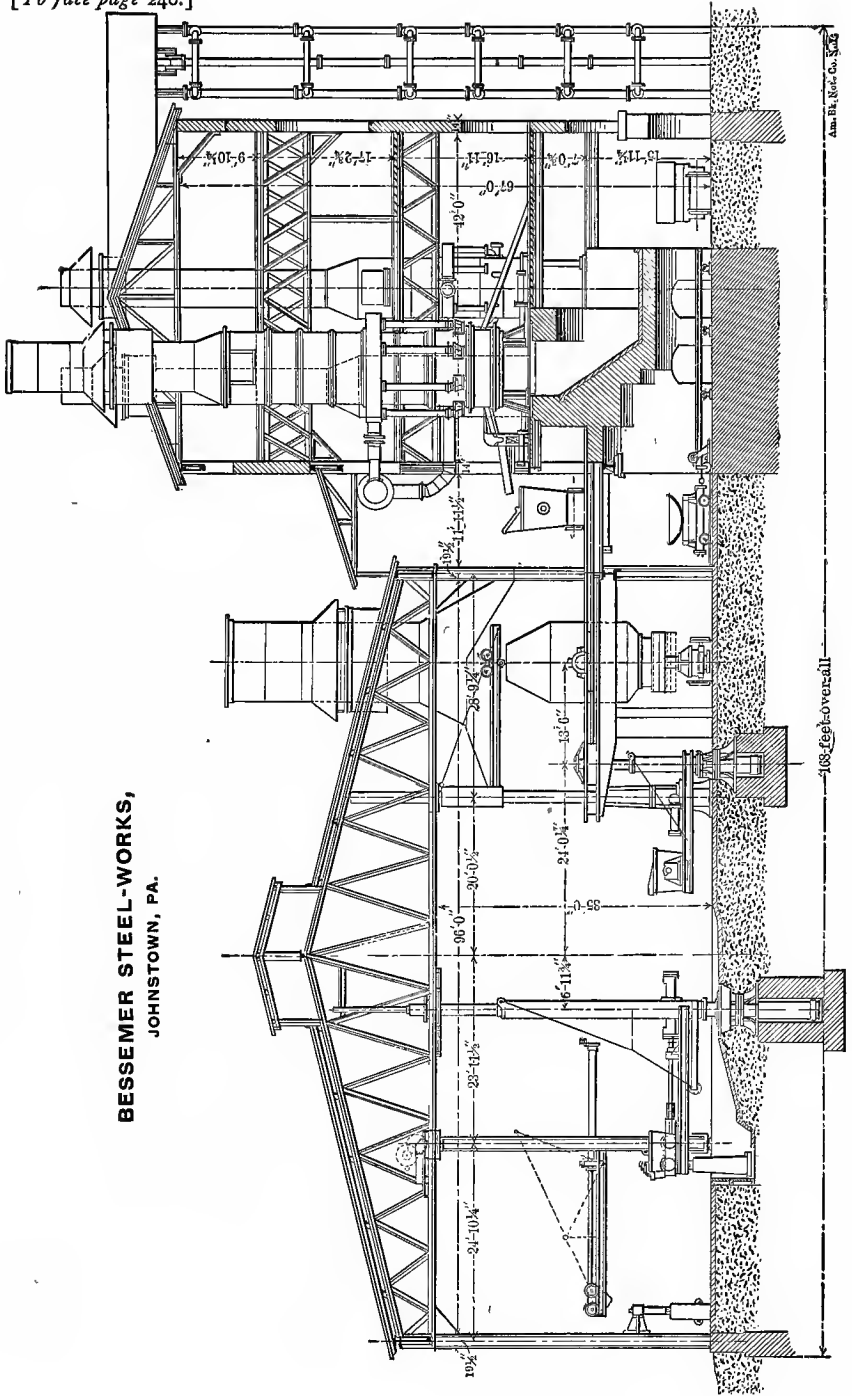

per annum. The charge has been gradually increased, and the number of heats as well, until 10 tons (10,160 kilogrammes) per charge, and 80 heats, or even 120 a day, giving a production of 300,000 tons (304,800,000 kilogrammes) per year, has been obtained from this plant.

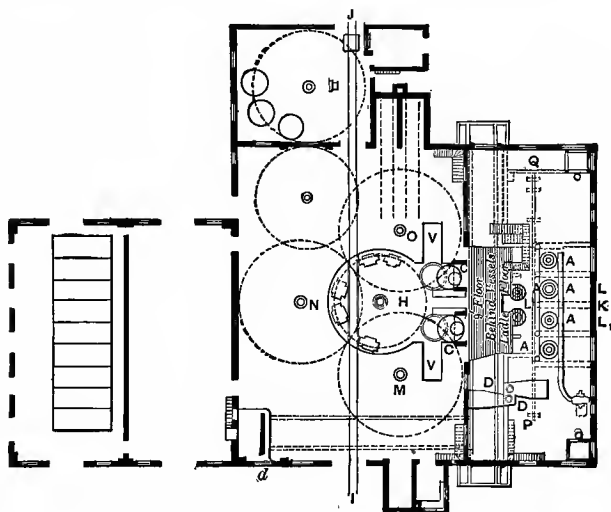

FIG. 43.—AMERICAN 5-TON BESSEMER PLANT.

The general arrangement of plant is shown in the accompanying drawings. Fig. 43 represents the ground plan as designed by Holley, and Fig. 44 is a section laterally on the centre line of the pit surrounding the converter.

The cast iron is melted in cupolas, *A, A, A, A*, Fig. 43 in plan, and seen in elevation in the section resting upon the second floor of the converting house, at the right of the converters, *C, C*.

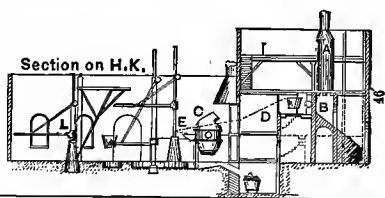

FIG. 44.—SECTION OF BESSEMER WORKS.

Materials are hoisted from the lower levels by hydraulic

elevators placed at each end of the charging floor, the one for fuel, the other for metal. The barrows on which the charge is transported are of iron, and carry about a ton (1,016 kilogrammes) of iron each, or $\frac{3}{4}$ -ton (772 kilogrammes) of coal. One barrow for each 8 or 10 tons of steel made per day is sufficient.

The metal is charged with the limestone required for the flux, and with about one sixth or one eighth its weight of fuel. This small consumption of fuel is one of the sources of economy secured by this plant. Reverberatory furnaces, often used elsewhere for melting, are less liable to injure the product by the introduction of sulphur and phosphorus when these elements are present in fuel and flux; but they are vastly more expensive in operation. With good fuel and pure limestone the cupola gives good economical results, however, without injury to the iron.

The cupola furnaces (Fig. 45) used are made especially for this work, and, as designed originally by Mr. J. B. Pearse, are made with much greater depth of hearth, greater tuyere area, and straighter boshes than the foundry cupola, in order to fit them to carry more iron and to melt it more rapidly. A usual form is of elliptical transverse section, 3.5 by 6.5 feet diameter (1.1 \times 2 metres) and 13 or 15 feet (4 or 4.6 metres) high, and with a total cross-section of all tuyeres of about 200 square inches (0.13 square metre). In charging these cupolas a bed is first laid of about $2\frac{1}{2}$ tons (2,540 kilogrammes) of fuel, above which is placed $1\frac{1}{4}$ tons (1,245 kilogrammes) of pig iron, then a half ton (508 kilogrammes) of fuel, and above that $1\frac{1}{4}$ tons (1,245 kilogrammes) of iron, and so on until the cupola is full to the charging door. A little limestone is now and then added as a flux. Such cupolas will melt

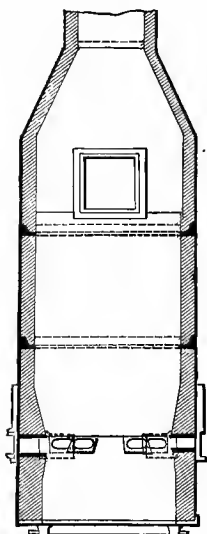

FIG. 45.

50 tons (50,800 kilogrammes) of iron in eight hours. From

the cupolas the iron, when ready, is tapped into 12-ton (1,392 kilogrammes) ladles standing on balanced scales, where it is weighed and where it remains until the converter is ready to receive it. This arrangement permits the determination to be made of the amount of spiegeleisen needed, and the great capacity of the ladles permits the manager to use them as reservoirs into which the molten iron from the cupola can be run instead of lying in the cupola hearths and interrupting the melting process when they become too full.

Air is supplied to the cupolas by fan-blowers, at a pressure of nearly or quite one pound per square inch (0.07 kilogramme per square centimetre). The cinder and other material dumped from the cupola slides down the inclined plane *B*, and are deposited near the cinder-mill, in which they are ground; they are then assorted, and any iron found in the mass is saved and remelted. The cinder is cooled and broken up by a stream of water from a hose.

From the ladles, *L, L*, the molten iron is poured into troughs, *D, E*, or runners, of which an upper movable section, *D*, is attached at one end to the ladle *L*, while the other end is carried on rollers, thus being given a power of self-adjustment as the ladle turns, and while discharging the stream of molten iron into a single lower fixed section, *E*, which receives it from both ladles. The latter has two branches, each leading to a converter, so that the metal can be charged into either, as required.

In this "melting department," as this portion of the steel-works is called, are also placed the furnaces, *D, D*, in which the spiegeleisen is melted. These are usually reverberatory furnaces; cupolas, although sometimes used, are found less well adapted to this work, since the metal is often kept in the molten condition for so long a time, that it might, in the comparatively cool and unheated

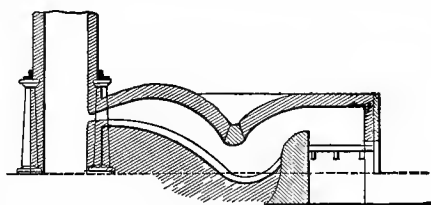

FIG. 46.

hearth of a cupola, get chilled. Where, as in the more productive works, the demand for spiegeleisen very frequently recurs, cupolas give good results; they are in all cases vastly more economical of fuel than the other furnaces.

In American works the reverberatory furnace, Fig. 46, is usually built with a slope, on which the metal is charged, near the flue, where the flame impinges most violently, and where it will be most rapidly melted, although it is then most liable to injury by oxidation of its manganese, which element has an exceedingly strong affinity for oxygen. In Europe, the furnace, Fig. 47, is often so built that the metal may be charged upon the slope of the bed, near the bridge-wall, where, although melted less quickly, it is less liable to oxidation.

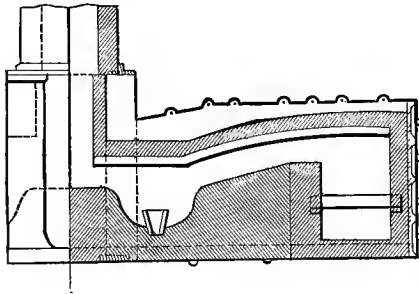

FIG. 47.

The space below the furnaces, as shown in the figures, is large enough to permit storage of raw materials for linings and repairs, and all common stores. A "crusher" and set of rolls on the cupola floor are used for crush-

ing the materials to be mixed for linings. A wide gangway is carried entirely through this building on the ground level, and gives a roadway for the carriage of material.

The "converting department" is placed in front of the melting department, and here two converters are mounted side by side, above the general ground level. In European works, Figs. 48, 49, they are usually placed in a pit sunk in the floor, and opposite each other, an arrangement which is less convenient, and causes the workmen to suffer more from heat than where everything is above ground. In front of the converters, *A*, is the casting pit, in the centre of which is a hydraulic crane, *C*, and around which are three other cranes, by which the ingots and ingot-moulds, *D*, are handled. Nearly on a level with the trunnions of the converters is another

floor, on which workmen may stand, and where materials can be placed while repairs are going on ; it is reached from the hoists, which open on this level, and the workmen enter upon it from the melting house by a side passage, when firing or repairing the converters, or when inspecting the converter bottoms. The cranes, *K*, swing completely around, the middle one handling all ladles and ingots in the pit, and transferring its load within reach of the other three, which latter convey it to the storage space, near the pit, or to a carriage, which traverses a railway of 30-inch (76.2 centimetres) gauge, passing over the scale, on which the weighing is done. At the left of the latter is the weigh-house, where, also, are rammed the converter - bottom linings.

The buildings at the extreme left contain the boilers, engines, and pumps. The engines used for blowing the air through the converters are of various forms. The most usual arrange-

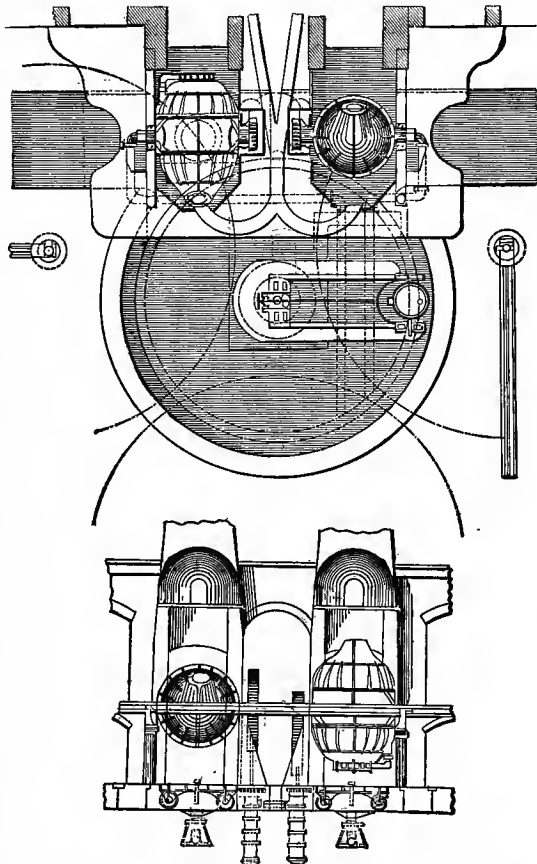

FIG. 48.

ment includes two independent engines, with steam and air cylinders and fly-wheels complete, in order to avoid the entire cessation of work that must otherwise follow upon the break-down of a coupled engine. Condensing engines 42 to 44 inches (1.07 to 1.12 metres) in diameter of steam cylinders, and about 54 inches (1.37 metres) in diameter of air-cylinders, with a stroke of piston of 5 feet (1.5 metres), and working steam of 60 to 70 pounds per square inch (4.2 to 4.9 kilogrammes per square centimetre), are adopted with a "5-ton (5,080 kilogrammes) plant."

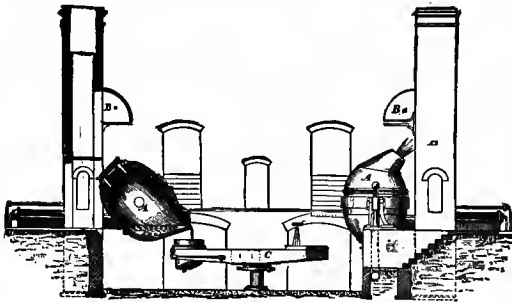

FIG. 49.

The water supply for the hydraulic cranes, and for the apparatus handling the converters and the hoists, is obtained from direct-acting steam pumps forcing water under a pressure, at the

accumulator, of 350 to 400 pounds per square inch (24.6 to 28 kilogrammes per square centimetre).

The converter is the only part of the plant which demands more minute description.

In the sketch, Fig. 51, is seen the lower part of this vessel, the general outline of which is seen in the above illustrations already described. The bottom of the

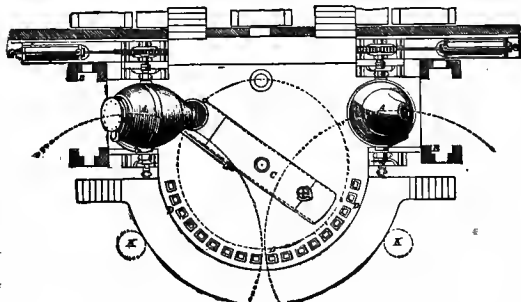

FIG. 50.

converter consists of a hollow detachable box, into which the

blast, which enters at the trunnion, is conveyed by side-pipes, and from which it rises through a large number of small holes, which traverse the lining mass, *A*, which protects the bottom from injury. The sides of the converter are also covered by the thick, infusible lining, *B, B*, of ganister or of ground siliceous stone, mixed with 10 to 12 per cent. fire-clay. The composition of ganister, and of the artificial substitute in use, is about: silica, 93; alumina, 4, with 3 per cent. of other substances. The mass, *A*, is mould-

ed upon the top of the blast-box, as seen below, and the imbedded tuyeres are firmly held by adhesion in the mass, and steadied also by the metal plate, which forms the top of the blast-box.

When the lining is worn down, and the tuyeres become too short for further safe working, the bottom is removed, and another, which has been meantime prepared, is put in its place as shown in the sketch. An open space, *C, D*, is left in order that no impediment may arise from too close a fit, and this space is tamped full by driving through an annular space, *D*, which is left open by the construction adopted. This space is three or four inches (7 to 10 centimetres) wide, and the filling is a mixture of ganister and fire-clay worked moist and driven snugly in place. This is done while the converter lining is still red hot; and occupies from three quarters to one hour after the opening has been trimmed and smoothed out.

The bottom requires frequent replacement; the con-

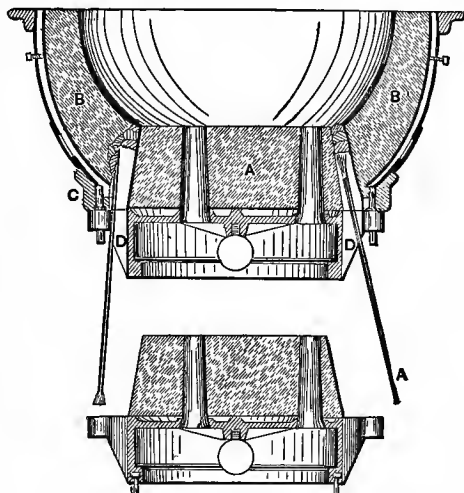

FIGS. 51, 52.—CONVERTER BOTTOM.

verter itself requires less frequent relining. The latter is divided into three separate sections, which can be lined independently. The relining of the upper and lower parts is usually done in the weigh-house. The middle part, being fixed by the trunnions, is relined in place.

These linings are worn away by both mechanical wear and by chemical action. The replacement of the converter bottom, when worn, does not cause delay, nor does it reduce production; but the relining of the converter itself often causes serious loss by stopping all work. During its working period, however, 80 or 90 charges per day of 24 hours can be made into steel, and 75 charges have been made in 12 hours.

In Holley's latest form of converter, the trunnion ring is detachable, and the whole converter can be removed for relining, another being kept ready to take its place at the removal of the first.

Of the pig metal melted in the cupola, about 85 per cent. appears in the form of ingot steel, the remaining 15 per cent. is lost by oxidation and by the formation of "skulls" and slag. A nominally 10-ton (10,160 kilogrammes) plant produces, usually, 20,000 to 30,000 tons (10,320,000 to 15,480,000 kilogrammes) per month, and sometimes greatly exceeds this figure. This rate of production has been steadily growing from the beginning, and is still increasing.

162. Operation.—The following is, in brief, the method of operation: The cast iron is melted in the cupola—or, if fears are entertained of the introduction of injurious elements from the fuel, in a reverberatory furnace, and after complete fusion, it is transferred to the converting vessel.

Before the iron is run into the converting vessel a fire of charcoal or coke is started within it, and a gentle blast turned on until the interior has been raised to a white heat. It is then ready for the charge, which has meantime been melted in a cupola or air furnace.

To fill the converting vessel, it is turned on its trunnions until the charge may be run into it, and so far that the molten metal shall not fill the tuyeres. The blast then is turned on at a pressure of from 15 to 25 pounds per square

inch (1.4 to 1.8 kilogrammes per square centimetre) according to the depth of the charge; it enters at the bottom in a multitude of fine jets, through orifices about a quarter of an inch (0.6 centimetre) diameter. The vessel is then turned into the vertical position, and the blast, permeating every portion of the liquid metal, seizes upon the oxidizable elements present, burning them out.

The operator watches the process with great care, observing the indications of the pressure gauge, the sound issuing from the converting vessel, the character of the flame, sparks and smoke issuing from the nozzle, and noting the duration of the phenomena exhibited as the operation proceeds.

At the instant that the blast commences passing through the metal, oxidation begins. The air, expanding violently as it rises, dividing into large globules or minute bubbles, seizes, as it goes, first upon the silicon. As the current passes from the converter to the chimney, it exhibits but little smoke, and carries with it large and brilliant sparks.

The metal, instead of being cooled by the great volumes of cold air forced through it, grows hotter and more liquid as combustion proceeds at the surfaces of the innumerable continually rising air-bubbles.

The whole mass becomes agitated until the vessel, and often its foundation, trembles. A regular muffled clapping sound is heard as the iron thrown up by the blast falls back again, and in six or eight minutes from the commencement of the process the sparks diminish suddenly in number, and a flame appears, first dull and red, but soon changing to a long tongue of fire, as the air, finding no more silicon with which to combine, seizes the carbon.

The silica formed in the first stage of the process combines with any oxide of iron then or subsequently present, and with it makes a glassy cinder that covers the surface and assists in retaining the heat of the iron.

As combustion progresses, the flame becomes, for a short time, partially obscured by smoke; then it clears again, and a voluminous clear white flame indicates that the graphite has all been burned away, that the combined carbon has

begun to leave the iron, and that if the process is not checked at the proper moment, the iron itself will soon begin to burn.

As the end of the operation approaches, some loss of iron is unavoidable. The temperature has become much higher than the melting point of cast iron; for the converter now contains a mass of nearly pure wrought iron, perfectly fluid, its whole mass pervaded by minute globules of air, which no longer finds sufficient combustible matter to satisfy its affinity unless it takes the iron itself. After the appearance of the white flame the detonations gradually cease, and after about fifteen minutes from the beginning the flame grows irregular and fitful, and then suddenly disappears.

The process is completed; the converting vessel is rapidly turned down, and the blast shut off. The iron is found, if then examined, to be almost perfectly pure malleable iron, which may be run into ingots and passed through the rolls or worked under the hammer.

As a low steel is, for most purposes, far more valuable than any wrought iron, and as the iron in its present state is "short," in consequence of the presence of iron oxide and of gas, the charge is next recarbonized to a certain extent before being removed from the converter. For this purpose some franklinite, spiegeleisen, or other manganiferous cast iron is melted in a cupola before the conversion of the charge is commenced. As soon as the process of decarbonization has ceased, a quantity of the recarbonizing material, in such proportion, usually 5 or 8 per cent., as is determined by the kind of steel required, is added to the purified iron.

The materials alloying perfectly, the carbon, manganese and silicon are diffused uniformly in proper proportion throughout the charge, and thorough intermixture is insured by blowing it in the converter when necessary. The whole time occupied in changing into steel a charge of say twenty thousand pounds (about 10,000 kilogrammes) of cast iron and forming it into ingots is less than half an hour.

The operation might be shortened, and the recarbonization avoided, by stopping the process before the carbon is all con-

sumed, and considerable quantities of cheap steel have been sometimes made in this way. But the rapidity with which combustion proceeds renders the method unreliable and the product variable in quality, and it is found far more satisfactory to complete the decarbonization and then to add a known quantity of carbon by the method already described.

The steel from the converter is run into moulds, where the ingots rapidly cool, and in 30 or 35 minutes the largest masses are taken out and placed in a heating furnace or a "soaking pit," and are kept at a sufficiently high temperature to work freely while the interior cools to such an extent that the ingot may be safely carried through the rolls or forged to the desired shape under the hammer.

The capacity of the converting vessels has recently been gradually increased until some larger manufacturers are converting 12 tons (12,192 kilogrammes) at a single charge; but converters of 5 tons (5,080 kilogrammes) and of 10 (10,160 kilogrammes) tons capacity are most usually employed, and larger vessels are seldom used in the United States.

The result of a moderately productive week's work of one pair of 10-ton (10,160 kilogrammes) converters gave in one instance a product of nearly 10,000 tons (10,160,000 kilogrammes), and produced 750 tons (660,000 kilogrammes) waste scrap. The product of an American plant, as here described, has in one case been reported as often above 40,000 tons (40,640,000 kilogrammes) of ingots for one month's work, and yielding 35,000 (36,000,000 kilogrammes) tons of finished product (rails).

The steel, when completely recarbonized, is, as above stated, poured off into a ladle, which distributes it to the ingot-moulds, which are made of gray iron of open texture, washed within with clay or plumbago, and set in a circle about the outer circumference of the ingot pit.

The ingots so produced are a foot (0.3 metre) or more square at their lower ends, tapering to a cross-section ten per cent. less at the top, and each ingot is usually so proportioned as to furnish material for either two or three rails,

where railroad metal is to be made, in order to save in the weight of rail ends returned as scrap.

The large ingots also furnish better steel, as they are worked more in the process of rolling. They are $3\frac{1}{2}$ to 6 feet (1.06 to 1.5 metres, nearly) in length, and usually weigh from 1,300 to 3,000 pounds (590 to 1,400 kilogrammes). Even heavier ingots are sometimes made. The ingots are sometimes hammered, but oftener rolled, into blooms of about one-fourth their original section, and are then sent to the rail-train.

Where the blooms are rolled, a "three-high mill" is generally employed, which is somewhat similar in general plan to those already described, but which are specially adapted to their work by ingenious and important details designed by their builders or the engineers of the works. In some of these mills, as designed by Mr. George Fritz, the movements of the bloom on the table, including the entering of it into the rolls, the lateral shifting, and even the turning of the piece, are all done by steam power.

In the United States the rail-train is usually made in three lengths of 21-inch (53 centimetres) rolls, or of two lengths of 24-inch (61 centimetres) rolls; they are "three-high," and are very strongly built; they can deliver 450 tons (457,200 kilogrammes) or more of finished rails per day of 24 hours. Rails are now made 60 feet long.

163. The Steel made by this Process is principally used in the manufacture of steel rails; a considerable amount is employed for boiler-plates, and also for axles and for running parts of machinery.

Good steel for either of these purposes is so low (0.20 or 0.15 per cent.) in carbon that it should properly be classed as ingot-iron. The desired strength, toughness, and freedom from liability to harden with changing temperature when placed under such conditions, for example, as are met with in boiler-construction and working, can only be secured by care in the selection of the best of ores, and choosing the best of pig-metal for the preparatory processes, and avoiding the introduction of excess of any of the hardening elements.

The pig-iron should not contain more than 2 per cent. silicon, usually, although $2\frac{1}{2}$ per cent. is often allowed, and $1\frac{1}{2}$ per cent. is considered a minimum; less would cause chilling, or working too cold in the converter. Too much silicon causes rapid wear of linings by producing excessive heat and from waste of iron, and makes the product too hard when the steel retains 0.1 per cent. silicon or more.

The pig-iron should contain less than 0.1 per cent. sulphur, and less than one-half that proportion of phosphorus is desirable. Equal care should be observed in selecting fuel and flux. The purer the iron, the higher is the percentage of carbon admissible in the finished steel.

164. Phosphorus is never desirable; but very good ingot-iron has been made from ores and pig-iron containing a considerable amount of that element.

Many attempts have been made to produce good mild steels by dephosphorizing iron "high" in phosphorus. Of such processes, those of Heaton and of Henderson are examples. The Ponsard Furnace, with blast nozzles like Berard's, has been used with some success in such attempts, and the use of basic linings in the Bessemer converter with Holley's improvements is one of the latest methods. This latter is due to Snelus, and to Thomas and Gilchrist, the former using the magnesian lime obtained from dolomite, and the two last-named chemists using a mixture of lime and silicate of soda; the same plan has been invented in the United States by Jacob Reese, and this method is known as "the basic dephosphorizing process."*

Jeans gives the following diagram, as prepared by Richards, to illustrate the action in such cases.†

In this case, the converter was charged with about 13,200 pounds (6,000 kilogrammes) pig-iron and about $7\frac{1}{2}$ per cent. of lime, and a blast of 25 pounds per square inch (0.176 kilogramme on the square centimetre) was applied. The phosphorus, carbon, and silicon were burned out, as seen in the

* The Basic Dephosphorizing Process; *Trans. Eng'rs. Soc.*, of West. Pennsylvania, Dec. 21st, 1880.

† *Steel; its History, Manufacture, &c.*, London, 1880.

diagram, the silicon going first at the rate of about one-fourth per cent. per minute for nine minutes, and then more and more slowly until, at the end of $17\frac{1}{2}$ minutes, it had practically all gone. The carbon commenced burning at the end of three minutes at the rate of one-fifth per cent. per minute, and was all gone at about the same time that the last of the silicon disappeared, at the end of the blow.

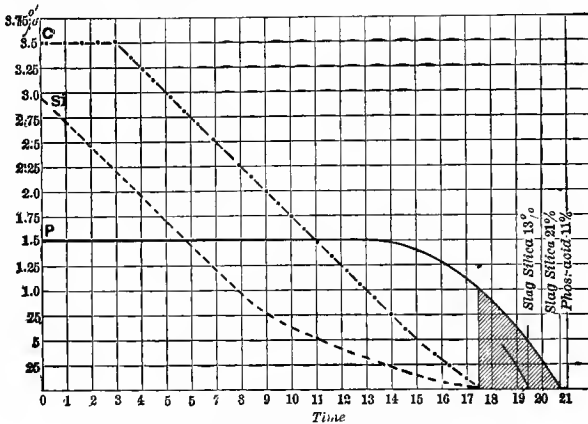

FIG. 53.—ELIMINATION OF ELEMENTS.

Six minutes from the beginning of the blow a mixture of one-third oxide of iron and two-thirds lime, to the amount of 13 per cent. of the charge, was introduced. It was only at the end of 12 minutes that the phosphorus, which amounted to 1.5 per cent. in the pig-metal, began to leave it, at first slowly then more and more rapidly, until at the end of 16 minutes it was burning at the rate of one-fourth per cent. per minute, leaving almost none at the end of the blow. This charge was overblown—*i. e.*, blown after the carbon had gone—three minutes, at the end of which period, $20\frac{1}{2}$ minutes from the beginning, the phosphorus had very nearly all been removed. The rails made from this charge are said to have been of excellent quality.

Where phosphorus exists in objectionable quantity, and the attempt is thus made to remove it by the use of lime and by substitution of basic for the acid silica linings usually adopted,

these basic linings are found far less durable than the acid lining, and the necessity consequently arises for the adoption of some method of quickly and cheaply replacing them.

By the plan adopted by Holley, this requirement is met. The whole converter, *A*, is made detachable from a supporting ring, *B*, which is carried by the trunnions—as seen in the figure—which latter and the ring are left in place when the converter is taken away for relining. Meantime another converting vessel, which has been previously prepared, is put in place, and the work goes on, while the first is taken away and relined at leisure. The delay for repairs, which would ordinarily reduce the output of American works one-half, is thus avoided, and the use of iron containing a small proportion of phosphorus becomes less objectionable.

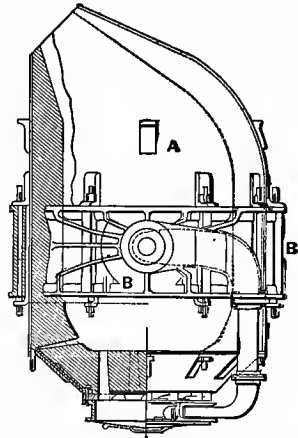

FIG. 54.—CONVERTER.

Dolomitic or magnesian limestones are used in the production of the lime, and this lime, formed into bricks, and baked, is fitted into the converter as a lining.

The cost of production is greatly reduced when, as is sometimes the case, the pig-iron is taken to the converter directly from the blast furnace. This has been done even when they are two miles or more apart.

165. The Quality of the Steel produced, which is primarily dependent upon the nature of the materials employed, may be improved by either or all of several chemical and physical processes.

The use of manganese is customary, in all standard methods of steel making, for the purpose of reducing the porosity of ingots; it acts by absorbing oxygen dissolved in or mechanically mixed with the molten metal, and by antagonizing the ill effects of any sulphur present. Where the metal is made very "low" in carbon, other expedients have been adopted,

as the use of silicon, which may be introduced as a silicate. This element is allowable in small proportion in ingot-iron, and if added in such quantities as to absorb all free oxygen, without combining to a serious extent with the iron, it is found to be of very decided value. The presence of minute

quantities of silicon in iron intended to be forged and welded is of advantage, since it acts as an efficient flux.

Boiler-plate "steel" usually contains less than 0.25 per cent. carbon, and is properly iron; the same may be said of rail "steel," and of that made for all common purposes and "uses." The softer varieties may be "spun" like yellow brass.

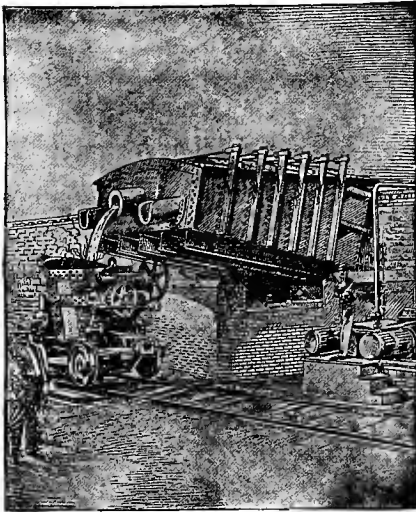

W. R. JONES' MIXER.

Capt. W. R. Jones' mixer serves the purpose

of a storage tank from which the supply of hot metal from the blast-furnaces is drawn for the converters, and also insures a much more uniform grade of iron, since several casts are mixed together and their inequalities neutralized. In order to secure a continuous supply of hot metal sufficiently uniform in regard to its different chemical constituents, the storage tank should have a capacity of at least four blast-furnace casts; so that for stacks of the 500-ton class, making 6 casts of 80 tons per day, the mixer should have a capacity of 320 tons.

The Whitworth method consists in the subjection of the metal, while cooling and solidifying, to the pressure of a powerful hydraulic press, and the effect, as will be seen hereafter, is as satisfactory as it is remarkable.

[To face page 262.]

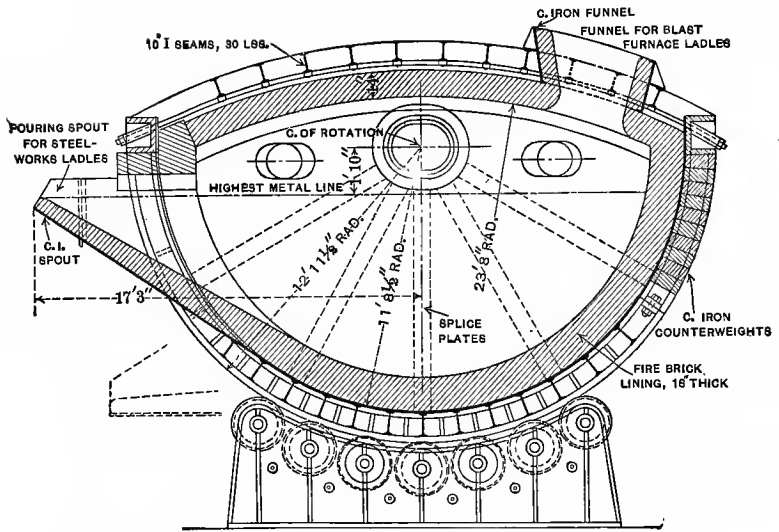

JONES' MIXER.—SECTION.

Cold-rolling is found to be useful where the metal is an ingot-iron, as well as in the case of the "weld-iron" made by puddling; but in both cases it is necessary to operate upon ductile metals to secure complete success.

166. The Decarbonization of Cast Iron by gases, by other methods than that just described, is a source of some of the steel of commerce. The puddling process has already been described, as practiced in the manufacture of "weld-iron," and it has been seen that it may be adopted in the manufacture of steel; the principal difference of method being that, in the latter case, the puddler checks the process before the carbon has been quite all removed, and balls up the sponge as soon as it can be made to cohere into a single mass.

The manufacture of *puddled steel* has been less practiced since the introduction of the open-hearth and the pneumatic processes of steel-making of Siemens, Martin, and Bessemer, but it is still carried on to some extent.

In this puddling operation the furnace is similar, usually, to that used in puddling iron. Heating may be, and sometimes is, done with gaseous fuel used in the regenerative puddling furnace. The cast iron selected should be of fine quality, and especially free from phosphorus; although the puddling process may be successfully worked with a more highly charged iron than can be used in either the Siemens-Martin, or the Bessemer process.

The presence of silicon in moderate amount, and of manganese, is an advantage, and sulphur, in small quantity, does no serious harm.

The charge is made up of gray iron, and the weight is usually 400 to 450 pounds (182 to 204 kilogrammes); it is first melted at a high heat, and then held at a temperature but little above that of fusion. It now has a cream-like viscosity, and parts with its carbon gradually, and surrenders some phosphorus. The process is one of "boiling," and the decarbonizing effect of the fettling is often promoted by special mixtures, and by the addition of cinder, iron-oxide, and other compounds, as the fluorides and titaniferous ores used in the Henderson process.

The rabble is used vigorously, and when the stirring has brought the whole mass of iron into intimate contact with the decarburizing materials, boiling takes place with great energy and considerable effervescence. The graphite, carbon and nearly all the silicon are quickly removed, and the iron has then become, if the operation is then checked, a white cast-iron of silvery fracture, hard, and very brittle; all carbon remaining is in combination with the iron. Continuing the operation, raising the temperature of the furnace, as the removal of carbon becomes more difficult, nearly to that reached in puddling iron, decarburization goes on until signs of incipient solidification are observed, when the heat is lessened until the metal glows with a dull yellow light. The temperature is reduced earlier as the carbon is desired in higher proportion. The sponge is balled, and the operation concluded, as in making iron.

In some cases, as in Riepe's process, the peroxide of manganese, common salt, and clay are mixed and used as a flux while the boiling is going on. Riepe produced either a mild steel or hard iron, and completed the steel-making process by reheating the bars of steel thus made in charges of about a half ton (508 kilogrammes) weight, in a strongly reducing flame on the bed of a reverberatory furnace constructed for the purpose. The introduction of the oxide of manganese assists, as it is stated, by taking up the silica which had previously caused waste by the formation of a silicate of iron, and the alkaline portion of the flux aids by displacing iron from its basic condition in the cinder.

The production of steel of uniform quality by puddling is rarely found possible, and the character of the product and its uniformity depend very greatly upon the experience and skill of the puddler. Careful inspection only can insure the sending to market, or the selection for specified uses, of the desired quality of steel.

Puddled steel has usually been found to cost about 25 per cent. more than puddled iron, in consequence of the greater value of the cast iron, and the greater length of time and higher skill needed in making it. This material is inter-

mediate in grade between iron and the hard steels, and can never be produced of such high quality, or so rich in carbon as to compete with the latter.

The following is a fair example of its composition and that of the iron of which it was made :

TABLE XXXVIII.
ANALYSIS OF PUDDLED STEEL.—PARRY.

	PUDDLED STEEL.	CAST IRON.
Carbon.....	0.501	2.680
Silicon.....	0.106	2.212
Sulphur.....	0.002	0.125
Phosphorus.....	0.096	0.426
Manganese.....	0.144	1.230
Iron, by diff.....	99.151	90.327
	100.000	100.000

Bérard's process is a method of steel-making which, in principle and in practice, is, in some respects, intermediate between the puddling and the pneumatic processes. In the latter, the attempt to refine the product by the introduction of non-oxidizing gases has not been successful, although attempted by Bessemer and by many other inventors, in various ways. The danger of chilling the metal by prolonging the operation beyond the period at which the removal of carbon is completed, is too serious to permit such methods to be made successful in any case yet known. Steam, carbon monoxide, and the hydrocarbons, the gases usually introduced, are incapable of increasing or of holding the temperature attained during the decarburizing process, and the former, even if highly superheated, abstracts heat rapidly, in consequence of its very high specific heat.

Bérard seeks this result by fusing cast iron in the reverberatory gas-furnace, and working the furnace with gaseous currents, which are alternately air and hydrocarbons, the former to give the desired heating effect, and the latter to remove the sulphur and phosphorus contained in the iron by offering

them hydrogen with which to combine. The furnace is supplied with its air and gases as is usual with Siemens furnaces. The furnace itself is double, and the two compartments are separated by a third space filled with incandescent coke. The bed of each melting division is made up of a mixture of clay and carbonaceous material. The entering gases and air are supplied to either compartment as required, and they are sent into the right and left compartments of the furnace alternately. That body of gas which passes over the bed of hot coke takes up carbon, and gives a reducing flame, while the stream which passes direct to the chimney is oxidizing.

Both hearths being charged with pig-iron, 1,320 pounds (600 kilogrammes) each, the molten iron stands on the hearth at a depth of about 4 inches (0.1 metre), and is subjected to the action of a blast from two tuyeres set at the side of the furnace inclined downward at an angle of about 45° , and dipping into the bath to a depth determined by an adjusting mechanism. The heated blast is sent in through one, and the carbon monoxide and hydrocarbons used, through the other. The operation is quite similar in theory to the pneumatic process, and the steel produced is similar, except that the refining is more complete here. The metal, when fully refined, is tapped off, and the subsequent treatment is not in any respect peculiar. The alternate heating and refining permits the operator to keep the iron fluid as long as is necessary, and the heating action of the blast and burning gases of the furnace counteract the cooling effect of the blast from the tuyeres. This process has not been fully introduced, and its commercial value is not determined. The method is here described as illustrative of the direction of attempted improvement.

167. Peculiar Steels are produced by the introduction of unusual elements into common steel, or by alloying such elements with iron.

“*Chrome-Steel*” is made by alloying iron or carbon-steel with chromium in proportions which are determined by the quality desired. The methods of manufacture are similar to those adopted in making carbon-steel, and it may be made

either on the open hearth or in pots. The latter is the usual method, and, in detail, is precisely like the standard process of making crucible steel, by melting iron in presence of carbon, except that the proper proportion of chromium is added. This is usually in the form of chrome ore; it is reduced by the carbon, and the metal finally produced contains both carbon and chromium. According to Kern, manganese may be dispensed with. Chrome-steel may also be made by fusing together chrome ore—which contains both chromium and iron—powdered charcoal, and any good flux, thus obtaining an alloy, ferro-chromium, which may be remelted with iron to produce chrome-steel, or used in the converter.

Three numbers are made by the manufacturers supplying the United States, of which No. 1, extra, is used for tools of the hardest kinds; it is said to be capable of cutting chilled cast iron; No. 2 is made for turning, and milling and planing tools; No. 3 is best fitted for making chisels, fine edge-tools, dies, and other similar work. Steels of special quality are made, when desired, for mill-picks, rock-drills, and such tools, for springs and for guns.

These steels have very peculiar qualities. Boussingault, who studied ferro-chrome alloys as early as 1821, states that the alloy must contain carbon if it is to be tempered, or is desired to possess elasticity.

Kern's formulas for mixtures used by him in making chrome-steel are as follows:

	I.		II.	
	LBS.	KILOS.	LBS.	KILOS.
Bessemer steel, No. 1	52.8	24.00	22	10.00
“ “ No. 2	11.0	5.00	48.4	22.00
Iron	11.0	5.00	4.4	2.00
Chrome ironstone	1.65	0.75	1.43	0.65
Limestone55	0.25	.77	0.35

	III.		IV.	
	LBS.	KILOS.	LBS.	KILOS.
Martin steel, No. 3.....	45.1	20.50	4.4	2.00
“ “ No. 4.....	10.	4.50	41.8	19.00
Refined cast iron.....	19.25	8.75	26.4	12.00
Chrome ironstone.....	1.65	0.75	2.75	1.25
Limestone.....	1.1	0.50	1.60	0.75

The Bessemer steel, No. 1, used in the above, contains from 0.20 to 0.25 per cent. of carbon; No. 2, from 0.45 to 0.55 per cent. Martin steel, No. 3, contains 0.80 to 0.90, and No. 4, from 1.0 to 1.3 per cent.

Kern considers No. 1 best adapted for steel plates and rifle barrels; No. 2, for parts of machinery, cannon, tires, and axles; No. 3, for instruments, cannon reinforce-rings, and saws; and No. 4, for chisels and planing tools.

In preparing the charges, chrome ironstone and limestone are calcined and ground, and the raw materials employed in the preparation of the steel, cut in pieces of one inch square. The mixture is placed in crucibles of fire-clay, previously heated. The chrome ironstone and limestone are put in the bottom of the crucible, and the other ingredients on top, and the heat is obtained from an ordinary coke crucible, or Siemens gas crucible, furnace.

The tenacity of these grades of steel is less than that of corresponding grades of American chrome-steels. The figures for the latter have been reported as high as from 73.1 to 88.8 tons per square inch (11,500 to 14,000 kilogrammes per square centimetre), while the Russian steel is stated to have, as a maximum, but about two-thirds the first figure. The ferro-chromium used has a varying composition, but sometimes contains 50 or even 60 per cent. chromium.

Complete analyses and statements of strength will be given in later chapters.

This steel has been extensively used in the construction of

safes and in tool-making, and the softer grades have been employed in bridge building.

Tungsten Steel, or wolfram steel, is an alloy of iron, carbon, and tungsten, which is made at several European works. It is not a new kind of steel, as Oriental damasked steels have been found to contain tungsten. Bernouilli found, by experiments in the Royal Foundry at Berlin, that when gray cast iron and tungstic acid are melted together, tungsten steel is produced, provided the iron is melted in a finely divided state, as in the form of chips or turnings.

The addition of tungsten to iron gives a peculiar hardness and strength, which, in the absence of carbon, is not increased by tempering. When the amount of tungsten present is considerable, this steel becomes very difficult to work.

The tungsten in these steels is usually derived from its principal ore, wolfram, a tungstate of iron and manganese, by reduction at a very high temperature with charcoal. The product is usually a compound of iron, tungsten, manganese, and sometimes tin. The ore requires purification before reduction, as it contains sulphur and arsenic. Of the ferro-tungsten thus obtained, from 5 to 25 or 30 per cent., according to the nature of the other materials used and character of the steel desired, is added to the iron and melted in pots with a flux, as in other methods of crucible-steel making. Tungsten is sometimes added to Bessemer and to open-hearth steel. Molybdenum is said to be better than tungsten.

Mushet's steel is thus made: Pulverized wolfram is mixed with its own weight of melted pitch; this mixture is added to the iron and flux in the crucible, and the whole is then melted in the steel furnace at a high heat.

Alloys of cast iron and tungsten are sometimes made and sold to steel-makers, who use them in admixture with carbon-steel.

Like chrome steel, tungsten steel, of the quality which finds a sale as tool steel, is quite easily worked at a red heat; but it must be handled by a careful and experienced workman to get the best results. The harder grades cannot be cut by the file, and no tungsten steel can be tempered; it is

shaped at one forging operation, and ground into exact form when cool.

The Author has found chrome and tungsten steels far more durable than the carbon steels with which they compete; on the other hand the difficulties and peculiarities noted in working them are obstacles which retard their introduction. Where the carbon steel cannot be made to stand, these peculiar steels are the only metals which can be used for cutting tools. Their great wearing power gives them especial value where gauges or standard sizes of tools are especially desired to retain standard size as long as possible while in use. Magnets made of these steels are said to possess great permanency.

By subjecting tools made of steels of this class, including those containing molybdenum, to rapid cooling from high temperatures (1500° to 1900° F.), the Taylor-White process produces a tool capable of cutting continuously at speeds far above those ordinarily practicable. (See Appendix.)

168. Other Kinds of Steel, and many other processes of steel making than those described have been proposed, and have, occasionally, been introduced; but none other has come into general use. Attempts have been made to produce so-called "phosphorus steels;" but the hardening and strengthening property of phosphorus, although undeniably great, is accompanied by such serious reduction of ductility and elastic range, especially when carbon is present, that no phosphorus steels have come into market that can be used for tools. Very low grades, or, more exactly, ingot iron in which a moderate amount of phosphorus occurs, have been made from ores containing considerable phosphorus, and, in the absence of carbon, are found to have a good degree of ductility and strength. The maximum percentage permissible in rails is said to be 0.28 to 0.33 per cent. when the carbon is below 0.25 or 0.20 per cent. Above this proportion, the metal is difficult to roll when hot, and is cold-short at ordinary temperatures. Such "steel" is made at Terre-Noire on the open hearth of a Siemens furnace. The gray pig-iron used con-

tains about 5 per cent. carbon, and $1\frac{1}{2}$ or 2 per cent. silicon; the white "forge-pig" used contained $2\frac{1}{2}$ to 3 per cent. combined carbon, and is free from silicon. The scrap iron and rail steel, which forms from two-thirds to seven-eighths the total weight charged, is, at Terre-Noire, also "high" in phosphorus. The following is the composition of a charge using white pig :

	LBS.	KILOGRAMMES.	PER CENT. P.
White pig-iron.....	3,850	1,750	0.1
Steel scrap.....	1,760	800	0.1
Old steel rails.....	7,370	3,350	0.35
Ferro-manganese (60 per cent.)...	308	140	0.27
	13,288	6,040	

Seven or eight hours are occupied in making a charge, and one furnace yields 17 or 18 tons (17,272 to 18,288 kilogrammes) in 24 hours; the steel contains 0.25 per cent. phosphorus. The quality of the product is greatly improved by working, and the ingot should be made large, and thus a large reduction secured in the rolling-mill.

Phosphorus works out, when re-heating steel, more rapidly than carbon, and, for this reason, this steel varies in quality, when reheated, more than common steel. Experiments by the Author have shown that phosphorus steels are very liable to crack in hardening if made sufficiently hard to temper; that they have a higher elastic limit than carbon steels of equal strength; that they possess somewhat greater elastic resilience, or shock-resisting power, but are more liable to break under shocks exceeding their elastic limit; that they do not make good tools, and do not temper well, but may be accepted for rails and similar uses when very low in carbon.

"Manganese steels" for edge tools are made with 12 per cent. manganese; "mild" steels with 10 per cent., if without carbon, and 20 per cent. for very hard steels.

CHAPTER VIII.

CHEMICAL AND PHYSICAL PROPERTIES OF IRON AND STEEL.

169. Chemically and absolutely pure Iron is probably an unknown substance. Nearly pure iron is made by several methods of manufacture, or it may be deposited by electrolysis. Such metal has an exceedingly strong affinity for oxygen, sulphur, phosphorus, and some other elements, and alloys readily with many metals which are always present in its ores, or in fuel or flux, in small proportions. As it approximates to the chemically pure condition it assumes more perfectly the character of a silvery white and very lustrous metal, soft, ductile, and malleable, and, though tough, not remarkably strong; it is very heavy, its density, as deposited by electrolysis, being 8.14; is very easily oxidized; and it is an excellent conductor of heat and electricity. In consequence of its greed for oxygen, even ordinary and impure merchant iron requires to be alloyed with some silicon or other fluxing element, to make it weld easily; but, thus alloyed, it welds readily at a bright red or a white heat, at which latter temperature it is in a pasty state. Its melting point is unknown, but is higher than that of commercial wrought iron, for which the melting point is given by Pouillet at about 2,910° Fahr. (1,599° Cent.), and higher than for hard steel (2,533° Fahr., 1,389° Cent.). Alloyed with minute quantities of those elements which are usually present in its ores, it becomes harder, stronger, less ductile, and of less density, and is, for purposes of commerce and construction, thus made more valuable. The elements which almost invariably contaminate it or alloy with it are carbon, silicon, sulphur, and phosphorus in small quantities, and traces are found of aluminum, calcium, titanium, tungsten, and other metals. The

purest ores only are used in the manufacture of the best qualities of iron and steel.

The familiar grades of iron—wrought iron, steel, cast iron—vary in chemical composition from approximate purity to compounds containing 5 per cent. or more of foreign elements, principally carbon and silicon.

Commercial wrought iron of good quality contains from 0.05 per cent. of foreign elements, in the softer and purer grades, to 0.30 per cent. or more in the harder irons. Its texture is more or less fibrous if made by the processes producing weld-iron, and it often exhibits some fibre, although from a different cause, even when worked into shape from ingots. In the former case the fibre is produced by the drawing out of masses of cinder, inclosed in the sponge, into long lines of non-coherent substance, as the iron is worked under the hammer or in the rolls; in the latter case each line is the trace of an air-cell, originally of spherical form, in the ingot, but which has been similarly extended in working. The fineness and silkiness of this fibre, and the general texture of the iron, are gauges of its quality.

Magnetism is readily induced in irons, and is stronger as the iron is purer; but it is more permanent as the iron contains more carbon or other steel-making elements; and this property affords another means of determining its quality, and gives some idea of its composition.

Oxidation usually occurs less readily as the iron becomes more complex in composition; but it does not occur at ordinary temperatures, even with the best wrought iron, except in the presence of both carbonic acid and moisture; rust once appearing on polished surfaces, accelerates oxidation.

The scales of oxide formed on iron when highly heated differ in composition and physical character from the rust formed under more usual conditions; it is magnetic, while rust is the peroxide of iron. The former is extremely hard, smooth, bluish-black in color, and is elastic and durable.

170. The Influence of the Elements found in iron and steel is determined, not only by their own character, but, as has already been stated, by their mutual interactions.

Carbon is the most important of all these substances. When added to pure iron, it hardens and strengthens, while reducing ductility and ultimate resilience. It also, in a proportion exceeding about one-half per cent. (or less, in presence of other hardening elements), confers upon the steel the property of hardening when suddenly cooled, and of regaining its original softness by slow reduction of temperature from red heat—in other words, the property of “taking a temper.” Below this limit, as in “boiler steels,” wrongly so called, containing 0.20 to 0.15 per cent. carbon, the metal should soften when suddenly cooled, and this fact furnishes a “test” for such metal. Between $\frac{1}{2}$ per cent, or something above, and $1\frac{3}{4}$ to 2 per cent. carbon, the quality of the steel varies from that of the softest of the “mild” steels, to the hardest of the tool-steels; passing the upper limit, the metal becomes too unmanageable and brittle for use even in the harder kinds of tools. Through this whole range the metal is capable of being forged, and can sometimes be welded even when containing as much as one per cent. carbon. The presence of silicon renders welding less difficult. Iron alloyed with over two per cent. carbon is rarely made in the refined state; all such metal is found in the market in the state of cast iron, which contains all those elements which crude iron brings with it from the ore, and from fluxes and fuels used in its reduction. Throughout the whole series, the amount of manganese, silicon, phosphorus and other “hardening elements” present, have an important influence in determining the character of the steel, and the effect of carbon as well.

The steels in the market are usually distinguished from the irons, malleable and cast, by their freedom from phosphorus, and the completeness with which they have been refined, as well as by the proportion of carbon contained in them.

The cast irons grow harder with increase in the proportion of *combined* carbon; but, passing a certain limit, they begin to exhibit the influence of graphitic carbon, and become softer and weaker, until, when containing five or six per cent. carbon, one-half of which is often in the graph-

itic state, they become very soft and easily cut, of low density, and of little strength.

The value of steel in the market approaches a maximum as it approximates to 0.8 or 1 per cent. carbon, with freedom from any other elements except manganese and silicon, which should be present in very small quantities.

Manganese hardens iron and steel, and, at the same time, usually diminishes its malleability and ductility to a less extent than does carbon. If, however, but little carbon is present, the effect of manganese is quite similar to that of carbon alone, and a steel can be made of very great tenacity, combined with great ductility and resilience. Its effect on metallic iron, in presence of other elements, is not fully determined. It is even considered by some chemists as simply an antidote to the other more injurious elements present, as sulphur and oxygen, while it is itself a lesser evil. It has usually been found that iron ores containing manganese make excellent steel.

This element is of value when the steel is to be forged or welded, and in the various processes of steel making, as a preventive of the formation of oxides that would impede in the former case, and by preventing that porosity which steel cast in ingots would always exhibit, in consequence of their absorption of oxygen, if manganese were absent. Manganese is very effective as a preventive of the hot shortness caused by sulphur, which latter element it counteracts very completely when present in the crude steel in moderate amount. Ingot-iron and steel low in carbon, and especially very low in phosphorus, is increased in strength and ductility also, by the addition of small doses of manganese, and the degree of hardening on tempering the steels is increased by its presence. Steel containing considerable carbon may take up nearly 1 per cent. manganese, if otherwise pure, and yet lose little ductility, while gaining considerably in tenacity and in tempering quality.

Mushet, one of the oldest and best authorities, considers that manganese should only be added as an antidote to sulphur, silicon, and oxygen, and that all these elements, as well as phosphorus, should be kept out of the steel to the utmost

possible extent. In this opinion, Siemens and other later authorities agree, and all unite in stating that toughness can best be secured by insuring purity of metal, whether iron or steel. Recent practice does not, however, follow this view, as the manufacture of a "manganese steel," containing little carbon, has become a well-established branch of steel making. Its presence in spring-steel has been found objectionable.

Phosphorus is the most injurious of all the elements which usually contaminate iron and steel. It confers hardness; but that quality can be far more satisfactorily obtained when desired, by the addition of other elements. It greatly reduces ductility, and causes a serious degree of cold-shortness in both iron and steel; even in foundry grades of cast iron it should usually not be admitted in higher proportion than $\frac{1}{2}$ per cent., except when fluidity is desired even at the expense of considerable loss of strength. Cast-iron containing phosphorus is peculiarly liable to break under shock, and the same is true of wrought iron and steel in which it may exist in measurable amount, unless it be the only hardening element present in any notable quantity. Good tool steel should not contain more than 0.010 or 0.015 per cent., but ingot-iron and mild steel may contain, if otherwise pure, as much as 0.1 per cent., which amount has actually been found in some spring-steel.

When nearly free from all other hardening elements, iron sometimes contains 0.35 to 0.40 per cent. phosphorus, and yet exhibits fair quality.

The effect of this element is to increase elasticity, to elevate the elastic limit, and to increase slightly the modulus of elasticity.

Wedding exhibits the method of variation of the maximum allowable percentage of phosphorus in iron and steel, varying in proportion of carbon, by a curve shown in full line in the figure. One-fourth the proportions thus given, as exhibited by the dotted curve, *T*, introduced by the Author, may be taken as the usual limit for metals of good reputation in our markets. Some few cast irons, having a reputation for fluidity when melted, contain higher propor-

tions. Wade's experiments on metal for ordnance indicate $\frac{1}{2}$ per cent. phosphorus to be the maximum allowable, and $\frac{1}{4}$ per cent. to be a usual proportion in such cast iron as is used for guns; such iron contains about 3 per cent. carbon.

Sulphur causes brittleness at high temperatures in all grades of iron and steel. Its effect is most marked in the absence of other impurities, and it is therefore most objectionable in the finer grades of tool

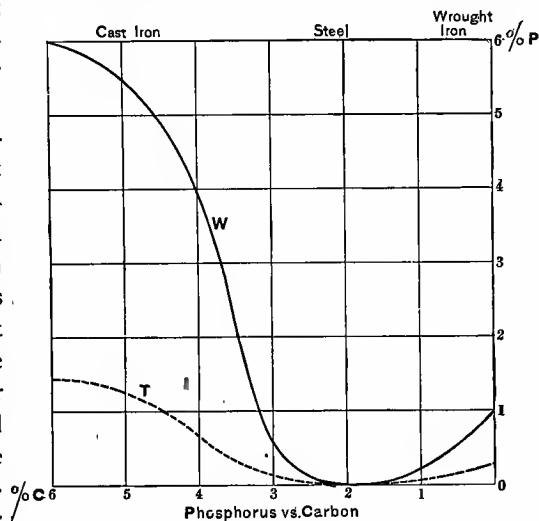

FIG. 55.

steel, and in iron or mild steel, which is to be welded. Its antidote is manganese, which greatly reduces its ill effect. Iron and steel containing 0.2 per cent. are not easily welded, and this figure may be taken as the extreme maximum allowable in any malleable iron or steel.

When bar-iron, containing a considerable amount of sulphur, is converted into steel by the method of cementation, a considerable amount of that element may be eliminated as bisulphide of carbon, and the steel made may be of fair quality. Using iron of a good degree of purity, the steel becomes almost perfectly free from sulphur, and particularly is this the case where manganese is present. Since the effect of sulphur is to produce hot-shortness only, its presence in moderate quantity is not objectionable in either iron or steel castings. It is stated by some authorities that iron and steel castings are stronger and tougher when containing sulphur, and it has even been added in making iron castings, both for

this reason and because it gives greater fluidity to the molten metal; ordnance iron has sometimes been thus treated.

Sulphur is eliminated to some extent in the Bessemer converter when the basic process is adopted.

Silicon is a hardening element, and its influence is the greater as the metal is otherwise purer. In weld-iron and in soft steels it is of value in small quantity where the metal is to be welded, either in the process of manufacture or in subsequent forging. In the various processes of making ingot-steel it is of use, like manganese, as a preventive of injury by oxidation, or by the formation of air-cells and production of porous ingots, and, consequently, of non-homogeneous blooms, bars, or rails. In the pneumatic process its presence has been seen to be of direct advantage in supplying fuel needed to elevate the temperature of the molten mass in the converter to a higher point than could be obtained by combustion of carbon alone. It is of further use, in some cases, if added after the blow, as it gives a sound ingot and a weldable steel. One-twentieth of one per cent. is said to be sufficient to produce a decided beneficial effect in this latter case.

In its hardening power silicon resembles carbon, which element it may replace to a limited extent. Good irons and steels usually contain from 0.10 to 0.25 per cent. of silicon; while cases are reported in which, in the absence of other hardening elements, between one and two per cent. of silicon has been found in iron of apparently good quality.

Bessemer cast irons are expected to contain from 2 to $2\frac{1}{2}$ per cent. silicon, but foundry irons should contain very little; when the latter contain an excess they become weak, brittle, and peculiarly liable to crack in large castings; this latter defect is exaggerated by the presence of phosphorus. Two per cent. may be taken as the usual limit for silicon in cast iron, one-half per cent. for the steels, and one-fourth or one-fifth per cent. for good wrought irons.

Nitrogen is said by many chemists to be invariably a constituent of all grades of metal which exhibit steel-like properties, and it is by some considered an essential constituent; it has been found in all grades of both iron and steel in propor-

tions varying from 0.01 to 0.20 per cent., the usual proportion being about 0.05 per cent.

All methods of steel-making include the exposure of the iron used to the action of nitrogenous compounds or of nitrogen in the gaseous condition; but the element has been found in wrought iron in higher proportion than in steel, and it seems not to be, in itself, a steel-making element.

All the familiar metals have been alloyed with iron, but the resulting product has in no case become commercially introduced. Nickel has been alloyed with iron, and iron has been added to bronze and to brass; in each case the alloy has exhibited some peculiar properties. Nickel steel has come into use for armor-plate and ordnance.

So-called titanium and silicon steels have been made; but analysis has not shown them to contain either metal in any notable quantity, and such peculiar qualities as they may have exhibited have been supposed to be due to the presence of other elements.

Tin alloys freely with iron, but no use has been made of the product. Nickel and cobalt alloy with iron and steel, giving them a whiteness and lustre, and without seriously impairing ductility when added in small doses. Gold and platinum will unite with iron and steel, and the latter was found by Faraday to add strength and to give fineness of grain when not exceeding in amount one per cent. of the whole. Antimony injures iron by making it brittle and difficult to work. Arsenic in minute quantities strengthens steel.

Copper has been found by the Author to strengthen and toughen steel, when added in very small quantity, and Tredgold* states that it has a similar effect upon cast iron.

Wrought iron containing some tenths per cent. of copper, is red-short; in some of the best irons from Siberia were found from 0.01 to 0.03 per cent. of copper, and in some specimens of steel 0.2 per cent.; this steel was not brittle, and had been used with success for manufacturing steel axles. The presence of copper was noted in several specimens of cast iron coming

* Tredgold on Cast Iron.

from blast-furnaces of the South Oural mountains. These specimens, when examined and analyzed, showed that the presence of copper in cast iron may amount to a higher percentage than in steel or iron without injuring the quality of the metal. The specimen examined was used for castings; it filled up the moulds well, and had a fine appearance; when freshly cut it had a dark-gray color. Under the microscope small grains of copper were easily seen in the mass of the metal. This cast iron had the following average composition: *

	Per Cent.
Iron.....	83.514
Copper.....	8.123
Tin.....	1.252
Cobalt.....	0.501
Silicium.....	0.952
Tungsten.....	0.125
Carbon.....	3.001
Manganese.....	2.312
	99.780

The case illustrates well both the variety and extent to which other elements may enter into union with iron.

171. The Chemical Composition of the various classes of iron and steel has already been indicated as determining their nomenclature and uses. Beginning with the most impure of the cast irons and passing through the several grades of cast iron, steel, and malleable or wrought iron, it has been seen that their qualities and their applications are generally determined primarily by the proportions of carbon present, and secondarily by the effect of sulphur, phosphorus, chromium, manganese, silicon, and the other less usual ingredients which give them peculiar characteristics.

Of the Cast Irons, "No. 1 Foundry Iron" is the softest grade, is richest in carbon, and is the darkest in color of all the irons; it is weak, moderately tough, of low density, and is quite fluid when molten. It is used principally for mixing with harder grades or for purposes which compel repeated or

* *Chem. News.*

prolonged fusion. It is the most expensive of all grades of cast iron. It is to a very slight extent malleable, ductile, and somewhat flexible, is very easily worked by the file and by cutting tools. Its fracture is bright and granular, and of a bluish-gray color. Its texture is finer and more close-grained as its color is lighter. When melted it has much more fluidity than the lighter grades, flows smoothly, and fills the moulds well, taking a good impression from the minutest lines of the mould, and rarely causes trouble by "cold shuts" or "blow-holes." The best qualities have a medium fineness and closeness of texture; a clear, dark-gray color; a clean, brilliant fracture, with sharp edges; and a density that is not far from 7.2. Coarseness of grain, a dull color, and irregular structure, indicate an inferior iron. When annealed, gray cast iron is softened, weakened, and reduced in density.

"No. 2 Foundry Iron" contains less carbon than No. 1, is harder, stronger and denser, and has a finer, closer grain; it is of more frequent use than either of the other foundry grades, and is the iron most called for in all ordinary kinds of work. Its specific gravity is about 7.3.

"No. 3 Foundry Iron" is still lower in carbon, is whiter, stronger, denser, and finer in grain. It is too hard and brittle for general use, and is purchased to mix with softer irons. It often has a slightly mottled surface of fracture.

The Forge Irons are numbered 4, 5, and 6 by many makers; of these the first is often called "Bright Iron," the second "Mottled," and the third "White." White iron is very hard and brittle, but strong and dense, attaining a specific gravity of 7.5 or more. It cannot be easily filed, but takes a very high polish if ground. Its fracture is clean, bright, and silvery white, usually granular, but sometimes plainly crystalline. It burns with bright scintillation at the melting temperature. Annealing reduces its density, but increases its strength.

The forge irons are generally converted into wrought irons by the puddling process. The rich gray irons containing silicon are converted by the pneumatic method. The carbon

contained in white iron is all combined, as it is in steel; that in the gray irons is, to a considerable extent, graphitic.

The appearance of the fracture and the physical qualities of the darker grades of iron are considerably modified by variations in the size of the castings made of them, and in the rate of cooling. A large casting cooling slowly retains much of its carbon in the graphitic condition, while a small piece rapidly cooled will become whiter, and will exhibit a "chill," produced by more complete combination of its carbon with the iron. This change affects the superficial portions of iron cast in contact with "chills," or masses of iron set in the mould for the purpose, to an extent which is determined by the grade of the iron and by the amount of silicon and carbon present. For example, a well known brand of "chilling iron" is thus numbered:

- No. 1.—Soft; does not chill.
- No. 2.—Harder; does not chill.
- No. 3.—Still harder; does not chill.
- No. 3½.—Just shows a chill on the surface.
- No. 4.—Chills to the depth of ½ to ¾ inch.
- No. 4½.—Chills to the depth of 1 to 2 inches.
- No. 5.—Mottled iron.
- No. 6.—White iron, "all chill."

The depth of chill is determined in each grade by the facility with which the carbon may be changed from the graphitic to the combined state.

172. Analyses of the several Grades of Cast Iron have been made in great numbers and with extreme accuracy. Examples of good foundry irons are the following, made from magnetic ores:

Carbon.....	4.81	3.94
Silicon.....	1.18	2.43
Sulphur.....	trace	0.04
Phosphorus.....	0.12	0.04
Manganese.....	0.99	0.11
Iron and loss.....	92.90	93.44
	100.00	100.00

The first is Swedish, the second is an iron made in the United States.

Of irons made from red hematite, Abel* gives the following:

ELEMENTS.	1.	2.	3.	4.
Carbon, graphitic....	0.	trace	trace	0.35
Carbon, combined....	3.22	2.24	2.30	1.86
Silicon	3.02	2.77	2.72	2.63
Sulphur	0.	0.01	0.05	0.10
Phosphorus	0.06	0.05	0.05	0.03
Manganese.....	0.11	0.07	trace	0.07
Arsenic.....	trace	trace	trace	trace
Copper.....	trace	trace	trace	trace

The very fluid irons known as "Scotch pig" (some of which are made in the United States); contain considerable phosphorus. Thus No. 1 irons have been found to give the following:

Carbon, combined.....	3.00	3.40 per cent.
Carbon, graphitic.....	0.28	0.46 "
Silicon.....	3.50	2.93 "
Phosphorus.....	0.98	0.75 "
Sulphur.....	0.02	0.04 "
Manganese.....	1.58	1.62 "
Copper	0.10	0.07 "
Iron and loss.....	90.54	90.73 "
	100.00	100.00 per cent.

The best of the real Scotch irons are made by smelting mixtures of black-band and red hematite ores. They have the very valuable quality of retaining their gray character in even very small castings; they melt easily, flow freely, and take a very fine impression in the mould. They shrink less than one per cent.—one-tenth inch per foot—and are very useful for mixing with lighter irons and with scrap. The cheaper brands contain too much silicon and phosphorus. Somewhat similar irons are made in the United States from ores of

* "Cast Iron Experiments."

Eastern Pennsylvania, which have nearly the fluidity and other qualities of Scotch iron with much greater strength.

American pig-iron (Acadia; Abel) made from red and brown hematites have the composition :

NOS.	1	2
Carbon.....	3.50	3.27
Silicon.....	0.84	0.67
Sulphur.....	0.02	0.01
Phosphorus.....	0.19	0.28
Manganese.....	0.44	0.37
Iron and loss.....	95.01	95.40
	100.00	100.00

As an example of a Bessemer pig-iron made in Northern New York we have : *

	Per Cent.
Carbon, combined.....	1.17
“ graphitic.....	2.88
Silicon.....	2.64
Sulphur.....	trace.
Phosphorus.....	0.066
Slag, etc.....	0.42
Iron.....	82.82
	<u>99.996</u>

The following series of irons illustrate the variation of grade with change of composition : †

Kind.	Gray.	Gray.	Gray Forge.	White.	White.
Carbon.....	2.48	3.12	3.74	2.32	2.23
Silicon.....	3.48	0.78	1.00	0.29	0.24
Sulphur.....	0.37	0.09	0.34	0.08
Phosphorus.....	0.22	1.03	0.70	0.86	1.53
Manganese.....	0.27	0.25	0.21
Iron.....	93.88	94.80	95.10	99.39	95.71

* *Trans. Amer. Inst. Mining Eng.*, Vol. II., p. 66.

† *Ibid.*

A "first-class iron," classed as No. 1 Gray Foundry Iron, made from equal parts Pennsylvania hematite and fossil ore, and having a soft and coarse-grained texture, contained, according to Britton's analysis :

	Per Cent.
Carbon, combined.....	0.56
" graphitic.....	3.43
Silicon.....	2.15
Sulphur.....	trace
Phosphorus.....	0.36
Calcium.....	0.07
Iron by difference.....	93.49
	<hr/>
	100.06

A good iron for the Bessemer process is reported by the same authority as having :

	Per Cent.
Carbon, combined.....	0.38
" graphitic.....	3.98
Silicon.....	2.45
Sulphur.....	trace
Phosphorus.....	0.09
Calcium.....	0.07
Manganese.....	1.25
Iron.....	91.72
Loss.....	0.09
	<hr/>
	100.03

American pig-irons of good quality contain usually about 6.5 per cent. of foreign elements.

A cast iron, which was rejected as unfit for use in large castings on account of liability to crack, contained 0.81 sulphur, 0.049 phosphorus, and silicon 3.08 per cent.; a specimen of good machinery iron, taken from the castings, contained, as the analysis was reported to the Author, sulphur 0.053, phosphorus 0.47, and silicon 1.37 per cent.

173. **An Examination of the Analyses** of the Ordnance-irons reported upon by Major Wade, U. S. A.,* shows the average of the best and condemned guns to have contained phosphorus in the proportion of 0.4 and 1.2 per cent., the best

* *Metals for Cannon*, p. 377.

guns containing one-third as much as those condemned ; the proportion of the graphitic carbon was not greatly different (2.1 and 2.7 per cent.), but the good iron contained twice as much combined (1.81 to 0.83 per cent.).

The specific gravity of the best class averaged 7.2, and the best of all about 7.26, while the condemned guns generally had a density of 7.02 to 7.08. The tenacities of the two classes were as 27,200 to 22,100 pounds per square inch (1,905 to 1,550 kilogrammes per square centimetre).

The following are examples of one specimen taken from each class as representative, respectively, of good and of bad metal for ordnance, or for any purpose demanding, above all other requisites, strength, and shock-resisting power, while yet requiring such ease of working as shall make its manufacture reasonably inexpensive : *

	NO. 1. Per Cent.	NO. 2. Per Cent.
Carbon, combined	1.70	0.80
“ graphitic.....	2.20	3.20
Silicon.....	0.30	1.08
Sulphur.....	0.04
Phosphorus.....	0.44	0.76
Manganese.....	3.55	1.30
Magnesium.....	0.06	0.10
Calcium.....	trace	trace
Aluminum.....	0.28	0.16
Iron	91.84	93.17
Specific gravity.....	7.22	7.08
Tenacity, lbs. per sq. in.....	31,734	18,335
“ * kgs. per sq. cm.....	2,220	1,285

In the above examples the quantity of manganese is remarkably large ; in the other examples exhibiting similar differences, it was present only to the amount of a fraction of one per cent. Ordnance iron usually carries considerable manganese, however.

The following is an example of an excellent and very strong iron for general foundry purposes, particularly for light and rather thin castings, as, for example, piano frames :

* Wade's Report, *Metals for Cannon*, pp. 375-396.

	Per Cent.
Carbon, combined.....	0.15
" graphitic.....	3.34
Silicon.....	1.20
Manganese....	0.50
Sulphur.....	0.08
Phosphorus.....	0.00
Iron by difference.....	94.73
	100.00
Specific gravity.....	7.28
Tenacity, lbs. per sq. in....	30,500
" kgs. per sq. cm....	2,136

174. Cold and Hot Blast Irons differ considerably in quality, and this difference is so marked and so generally well understood that the market prices of iron, made by the two methods differ greatly.

The higher temperature of furnaces having a hot blast causes a more complete deoxidation of the ores and the reduction of elements which are less readily deoxidized at the lower temperatures of cold-blast furnaces. The effect of heating the blast is, therefore, to cause loss of quality by increasing the proportion of deleterious elements reduced, and which combine with the iron, while greatly increasing the yield of the furnace, and decreasing the cost of fuel. When the finest quality of iron is demanded, pure ores, fuel free from sulphur and phosphorus, and flux equally pure, must be used. Hence "Cold Blast Charcoal Iron" is demanded in many cases, to the exclusion of other grades.

It has been stated by some writers that the amount of phosphorus is greater in hot than in cold-blast iron. This is considered by Percy and other chemists, and by experienced furnace-men a mistake, as it is found that all phosphorus goes into the iron in any case.

175. Charcoal, Coke, and Anthracite Irons differ in value for the same reason that cold-blast and hot-blast irons differ. Coal, as mined, usually contains some impurities, and some kinds of bituminous coal are very seriously contaminated by sulphur. Anthracite, used as fuel in the blast furnace, while cheap in certain localities, and convenient to handle, and while giving intense heat, has some objectionable

qualities; the "anthracite irons" are, therefore, often found to be of unsatisfactory character. Bituminous coals are sometimes used "raw" in the furnace, and the "raw coal iron" thus made is often very hot-short, in consequence of the presence of an excessive amount of sulphur. To secure immunity from this injury, the bituminous coals are usually coked, and the iron made with coke is, usually, if the flux is free from phosphorus, of good quality. Charcoal has the least proportion of injurious elements of all the fuels used in making iron in the blast furnace, and the charcoal irons are, therefore, of better quality, other things being equal, than the other kinds of cast iron. Charcoal furnaces are also usually small, as this fuel is too weak to carry a heavy burden, and the temperature attained within them is less likely to become excessive. They are usually supplied with a blast that is either cold or very moderately warmed—a circumstance which aids in securing excellence of quality of product.

176. **The Chemical Change produced by Puddling**, and usually in the manufacture of either weld or ingot iron, has been described as a removal of the impurities contained in cast iron, the principal of which are carbon and silicon. This process is traced by Dr. Hartmann* in a series of analyses which are, in part, given below.

Beginning with a fair quality of No. 3 cold-blast gray pig-iron made with coke, and having the composition :

12 M.	FIRST ANALYSIS. Per cent.	SECOND ANALYSIS. Per cent.	AVERAGE. Per cent.
Carbon.....	2.320	2.230	2.274
Silicon.....	2.770	2.670	2.720
Phosphorus.....	0.580	0.710	0.645
Sulphur.....	0.318	0.228	0.302
Manganese and Aluminum.....	traces	traces	traces
Iron.....	94.059	94.059	94.059
Total.....	100.047	99.957	100.

* Waltz und Puddle Meister.

The charge of 200 pounds (100 kilogrammes) became fully melted in forty minutes. The silicon had already begun to burn out very rapidly, and the carbon had remained unchanged. One hour from the time of charging the sample taken out contained

	Carbon.	Silicon.
Original pig.....	2.274	2.720
First sample, 12.40 P.M.....	2.726	0.915
Second sample, 1.00 P.M.....	2.905	0.197

The carbon had increased 0.629, whilst the silicon had diminished over 90 per cent.

A second sample contained

1 P.M.	First Analysis.	Second Analysis.	Average.
Carbon.....	2.910	2.900	2.905
Silicon.....	0.226	0.168	0.197

The first differed from No. 1 in being slightly malleable when hot, whilst No. 1 was brittle. The cinder remained after cooling on the surface, and not mixed with the metallic iron, as in the second analysis of sample No. 3, which was taken out five minutes later.

Boiling soon commenced, and the sample next analyzed contained a considerable amount of cinder, which was with difficulty removed. It contained

1.10 P.M.	First Analysis.	Second Analysis.	Average.
Carbon.....	2.468	2.421	2.444
Silicon.....	0.188	0.200	0.194

This sample consisted largely of minute globular grains adhering to each other and to the slag with which they were mingled with a strong glutinous adhesion, even when very hot. The grains were black, lustrous, and very brittle.

Eighty minutes from the beginning, a sample taken out for analysis somewhat resembled the last. While cooling it, little jets of blue flame were seen to burst out from it. The grains were finer than before, and their coherence was so slight that the mass was easily broken up. Their color was a lustrous black, their fracture silvery white, and the metal

was as brittle as glass. The carbon and silicon contained were as below:

1.20 P.M.	First Analysis.	Second Analysis.	Average.
Carbon	2.335	2.376	2.355
Silicon.....	0.187	0.178	0.182

The boiling was in full operation when the above sample was taken, the heat had been reduced, and the puddler was working the bath with his rabble. The molten mass had swollen to four times its original volume. The silicon was still passing off, and the carbon had become somewhat reduced in amount.

At 1.35 P.M., ninety-five minutes from the beginning, boiling ceased, and the mass began to shrink in volume. The carbon had ceased to burn rapidly, and the bubbling carbon monoxide no longer puffed up the semi-fluid iron. The damper had been nearly closed, the flame had become strongly charged with smoke, and the puddler had begun to "ball up" the sponge.

The sample now taken contained:

1.35 P.M.	First Analysis.	Second Analysis.	Average.
Carbon	1.614	1.681	1.647
Silicon.....	0.188	0.178	0.185

It had lost a large amount of carbon since the preceding sample was taken, but the silicon had been but slightly changed. The sample was somewhat malleable, and could be beaten flat and smooth by the hammer.

In five minutes more a sample taken out gave:

1.40 P.M.	First Analysis.	Second Analysis.	Average.
Carbon	1.253	1.160	1.206
Silicon.....	0.167	0.160	0.163

In this case the appearance was similar to the last. Blue flames of carbonic oxide appeared while it was cooling; its grains had increased in size and could be welded together. The slag was more easily separated than before. Just at this time the mass in the furnace was divided, the metal being

separated from the great mass of cinder by the puddler, as he made up his ball.

A sample taken out at 1.45, after 105 minutes' working, contained still larger grains, and analysis showed the rapid loss of carbon, already noted, to be still going on. The grains were decidedly more malleable than before. This contained:

1.45 P.M.	First Analysis.	Second Analysis.	Average.
Carbon	1.000	0.927	0.963
Silicon.....	0.160	0.167	0.163

Five minutes later the metal contained:

1:50 P.M.	First Analysis.	Second Analysis.	Average.
Carbon.....	0.771	0.773	0.772
Silicon.....	0.170	0.167	0.168

The grains were still larger, more coherent, and more malleable and tenacious. Each grain was coated with slag, and was thus perfectly protected against oxidation, as was shown by the fact that portions of the sample remained in the laboratory unoxidized many months.

The puddle-ball was next hammered, and rolled into a bar, which was found to contain:

	First Analysis.	Second Analysis.	Average.
Carbon.....	0.291	0.301	0.296
Silicon.....	0.130	0.110	0.120
Sulpbur.....	0.132	0.126	0.134
Phosphorus.....	0.139	0.139

The puddle bar was cut and piled, and was rolled into wire-iron, which was found to contain:

	First Analysis.	Second Analysis.	Average.
Carbon.....	0.100	0.122	0.111
Silicon.....	0.095	0.082	0.088
Sulphur.....	0.093	0.096	0.094
Phosphorus. ...	0.117	0.117

All four elements, sulphur, phosphorus, silicon, and carbon, are seen to have been reduced to a minimum, which is, in each case, not far from one-tenth of one per cent. Here,

as in the basic pneumatic process, the phosphorus is evidently the last to go ; but it does begin to pass out at the end of the puddling process after the burning out of the other elements has nearly ceased, and its reduction continues—even during the process of working the sponge, and of making the bloom and the bar.

Collating all these analyses, we have :

SAMPLE.	TIME P.M.	CARBON.	SILICON.
Original pig.....	2.275	2.720
No. 1.....	12.40	2.726	0.915
No. 2.....	1.00	2.905	0.197
No. 3.....	1.5	2.444	0.194
No. 4.....	1.20	2.305	0.182
No. 5.....	1.35	1.647	0.183
No. 6.....	1.40	1.206	0.163
No. 7.....	1.45	0.963	0.163
No. 8.....	1.50	0.772	0.168
Puddle bar.....	0.296	0.120
Wire-iron.....	0.111	0.088

Comparing these results with the account already given of the pneumatic process, it is seen that the order of operations and the method of removal of foreign elements is precisely the same in both. The silicon starts first, and immediately on subjecting the molten pig-iron to the oxygen of the air ; after the silicon has nearly reached a minimum, the carbon rapidly passes out, and it is only when both are nearly gone that phosphorus begins to pass off ; dephosphorization is a process which only goes on when no other oxidizable metalloids are present. The slag remaining in the furnace, after the withdrawal of the balls, had the following constitution :

Silicic acid.....	16.53
Protoxide of iron.....	66.23
Sulphide of iron.....	6.80
Phosphoric acid.....	3.80
Protoxide of manganese.....	4.90
Alumina.....	1.04
Lime.....	0.70
Total.....	100.00

Thus the slag contains nearly all the impurities of the original pig metal, as was remarked in an earlier chapter.

Finished Malleable, or Weld-iron, as made by puddling in the instance above cited, has been seen to have been a composition, which, allowing $\frac{1}{2}$ per cent. for cinder and other undetermined constituents, contained :

Carbon.....	0.111
Silicon	0.088
Sulphur.....	0.094
Phosphorus.....	0.117
Slag, etc.....	0.500
Iron by difference.....	99.090
Total.....	100.000

Swedish iron of fine "J. B." quality, which is a good standard for comparison, has a composition, according to Percy, of

Carbon.....	0.087
Silicon	0.056
Sulphur.....	0.005
Arsenic.....	trace
Iron.....	99.220

Copper is said by Eggertz to be present in some Swedish iron to the extent of 0.03 per cent.

Lowmoor iron, made for armor-plate, is reported by Percy as containing :

Carbon.....	0.016
Silicon.....	0.122
Sulphur.....	0.104
Phosphorus.....	0.106
Manganese.....	0.280

with traces of cobalt and nickel. It has a specific gravity of 7.8, and a tenacity of 55,202 pounds per square inch (3,881 kilogs. per square centimetre).

A remarkably pure sample of Bowling iron was reported*

* *Appleton's Chemical Journal*, 1873, p. 15.

as made from a pig, of which the analysis accompanies that of the wrought iron made from it thus :

	PIG.	BAR.
Carbon, combined.....	0.581	} 0.272
“ graphitic.....	3.155	
Silicon.....	1.346	0.000
Sulphur.....	0.070	trace
Phosphorus.....	0.635	0.000
Manganese.....	1.472	0.000
Iron by difference.....	92.741	99.798
Total.....	100.000	100.000

This is the purest iron made, commercially, of which the Author has record.

These are all extraordinarily good irons, and are such as are made by but few makers of weld-iron either in the United States or in Europe.

The following analyses made by Blair,* of four samples of the purest irons supplied in the market for chain-iron, are of value as illustrative of the character of the best weld-irons made for general use, and of very good iron (two each).

MARK.	O, $1\frac{3}{4}$ "	L, $1\frac{1}{2}$ "	Px, $1\frac{3}{4}$ "	K', $1\frac{1}{2}$ "	D, $1\frac{1}{2}$ "
Carbon, combined.....	0.033	0.429	0.057	0.069	} 0.024
Carbon, graphitic.....	0.009	0.024	0.009	0.010	
Silicon.....	0.073	0.105	0.020	0.159	0.108
Sulphur.....	0.004	trace	0.001	0.004	0.005
Phosphorus.....	0.078	0.065	0.075	0.161	0.158
Manganese.....	0.005	0.006	0.009	0.026	0.038
Copper.....	0.046	0.008	0.008	0.079	0.018
Cobalt.....	0.034	trace	0.020	0.027	0.031
Nickel.....	0.037	0.011	0.023	0.034	0.021
Slag.....	0.974	0.326	1.214	0.470

Of irons of lowest grade analyzed are the following :

* Report of U. S. Board on Tests of Iron, Steel, etc., pp. 247-248.

MARK.	<i>P</i> , 1''	<i>Ƴ</i> , 1½	<i>M</i> , 1½	CONTRACT.
Carbon, combined.....	0.025	0.043	0.053	} 0.026 0.000
Carbon, graphitic.....	0.008	0.008		
Silicon.....	0.182	0.303	0.187	0.238
Sulphur.....	0.009	0.003	0.011	0.046
Phosphorus.....	0.250	0.213	0.166	0.328
Manganese.....	0.033	0.007	0.012	trace
Copper.....	0.081	0.011	0.498	0.134
Cobalt.....	0.037	0.013	0.047	0.039
Nickel.....	0.057	0.008	0.026	0.042
Slag.....	0.848	1.230	0.994	0.768

Of the whole collection that sample marked *Px*, was considered best for general purposes; it is seen to have had a very small proportion of impurities, although considerable slag was mechanically mixed with it.

The iron marked *O*, had remarkable ductility, and but little tenacity. *L* was very strong, but its high percentage of carbon made it comparatively brittle, and it was difficult to weld; it is, properly, "weld-steel." *Ƴ* was weak, brittle, and of unsatisfactory quality, in consequence of the presence of an excessive amount of silicon and of slag. *M* had an unusual proportion of copper, and was strong and moderately ductile, but it was almost impossible to weld it properly; once welded, however, the point of junction was very strong.

It was concluded from the study of the series of irons from which the above are selected, that phosphorus may be allowed in any proportion less than 0.10 per cent., and may even be of advantage where the carbon is below 0.03, and silicon less than 0.15 per cent. Silicon in excess, it is concluded, reduces strength, but loss of tenacity and ductility are oftener due to the presence of silica than to that of silicon. It was found that the same brand of iron may vary greatly in chemical constitution and physical character. With iron of fairly good composition, the quality is determined much more by differences in working, and peculiarities in method of manufacture, than by minute differences of composition such as usually exist.

Meteoric Iron is of no value to the engineer, and is of interest only as an example of native iron. A sample analyzed by Cairns contained :

Iron	81.480	Calcium.....	0.163
Nickel	17.173	Carbon.....	0.071
Cobalt.....	0.604	Silicon.....	0.032
Aluminum.....	0.088	Phosphorus.....	0.308
Chromium.....	0.020	Sulphur.....	0.012
Magnesium	0.010	Potassium.....	0.026
Total.....			99.987

Of the twelve elements quantitatively determined by this analysis, aluminum, calcium, and potassium have been rarely observed in meteoric iron—meteors free from silicates—while the absence of copper, tin, manganese and sodium, is to be noted.

The reduction of cast iron to the malleable state by the process described (Art. 145) as *malleabilizing*, has been studied by Dr. Miller, who gives the following analyses* of the cast iron used, and of the product :

Carbon ; combined.....	2.217	0.434
Carbon ; graphitic.....	0.583	0.431
Silicon.....	0.931	0.409
Aluminum	trace	trace
Sulphur.....	0.015	0.000
Phosphorus.....	trace	trace
Sand.....	0.502	

Carbon, in the combined state, was greatly reduced, while the graphitic carbon remained little changed. The silicon was reduced one-half, and the sulphur entirely removed ; this reduction of sulphur has been observed in that process of cementation also which yields cemented steel.

177. The Process of Cementation and production of blister-steel has been carefully studied by many chemists. Boussingault † subjected a sample of fine Swedish iron to this process, with the following results :

The cementing-boxes had a capacity of 175 cubic feet (4.9

* Percy, p. III.

† Comptes Rendus.

cubic metres), and each held 30,000 pounds (13,630 kilogrammes) of iron, and about one-eighth that weight of the brasque, which supplied carbon to the metal. After cementation, the steel, which had then been in the box a month, including time allowed for cooling, presented a silver white fracture, and had undergone a change, which is exhibited by the accompanying table :

	Weight.	Iron.	Carbon.	Silicon.	Sulphur.	Phosphorus.	Manganese
Iron....	2,000 gr.	99.47	0.03	0.0106	0.0015	0.0057	0.0090
Steel ...	2,026 gr.	99.57	0.16	0.0031	0.0005	0.0066	0.0071

178. Crucible Steels, whether made by cementation and subsequent fusion or directly by fusion of iron in presence of carbon, have the same composition in the same grade, except that the former method eliminates impurities rather more perfectly than the latter. Steels are graded by their physical structure, as seen by the eye of the experienced steel-maker. This grading is done with wonderful exactness, and the grades so established are usually in precisely the order of their proportion of carbon. Analyses, made by Langley for Mr. Metcalf, of a set of eight samples selected for analysis, and for tests of their strength by the Author, gave the following composition :

TABLE XXXIX.
COMPOSITION OF STEELS.

NO.	IRON BY DIFFERENCE	DIFFERENCE.	CARBON.	DIFFERENCE.	SILICON.	PHOSPHORUS.	SULPHUR.	MANGANESE.	REMARKS.
1	99.554404029	.022	trace	} Underdetermined.	Maximum errors. Silicon00 002 Phosphorus00 01 Carbon00 03
2	99.325	.129	.599	.195	.039	.035	.00 002		
3	99.143	.182	.789	.190	.026	.040	.00 002		
4	99.062	.081	.856	.067	.023	.056	.00 003		
5	98.965	.097	.867	.011	.126	.040	.00 000		
6	98.801	.164	.939	.072	.205	.037	.00 000		.00 018
7	98.745	.056	1.036	.097	.181	.029	.00 000		.00 009
8	98.673	.072	1.166	.130	.138	.019	.00 004		.00 000
Mean differences.		.0976	0.952					} Underdetermined.
									Max. Min.
									Iron..... .182 .056
									Carbon... .195 .011

A year afterward, the same steel-maker selected twelve samples in similar order with the following result (Fig. 57) :

Below are diagrams, showing the relations of the different elements in these two series. The break in the column

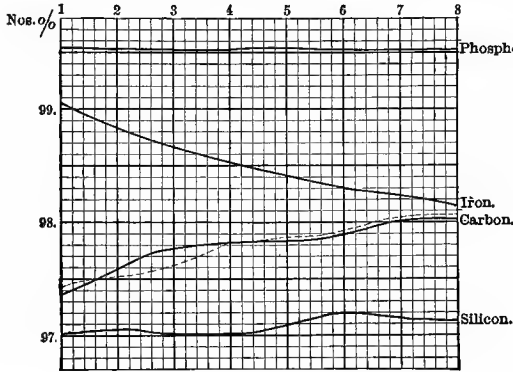

FIG. 56, FIRST SERIES.—TABLE XXXIX.

of differences of iron in Table XXXIX. is due to the abnormal amount of silicon in No. 6, from, doubtless, some accident in taking the drillings.

The dotted line in the first diagram shows the carbon of

the second series. The vertical scale is one-tenth per cent. to each division.

It is seen that the carbon is the only element which follows the change of grades; the other elements are almost invariable in all samples.

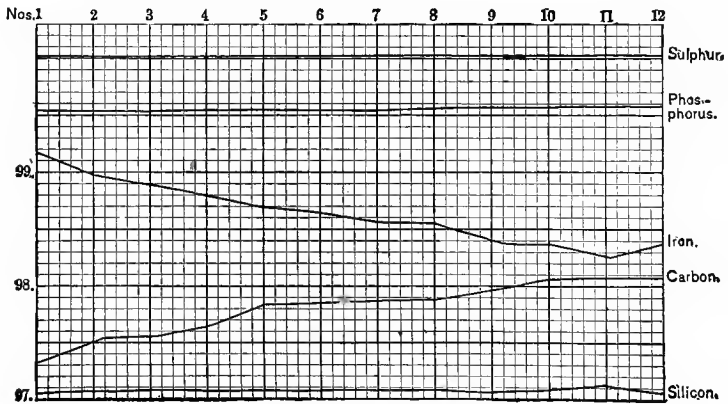

FIG. 57, SECOND SERIES.

Of all these steels, the only example of a "mild steel" is No. 1, in the first series, and Nos. 1, 2, and 3, in the second.

The higher numbers are tool-steels, and the intermediate grades are machinery steels, although of good composition for soft tools. It is evident that, where the steel is known to be made from pure material, the engineer may rely either upon tests made by an expert chemist, or upon the eye of the experienced steel-maker, in selecting the steel required for any specified purpose.

A set of steels analyzed by Blair, for the U. S. Board, as above, had the following composition :

NUMBER.	TOTAL CARBON.	SILICON.	SULPHUR.	PHOSPHORUS.	MANGANESE.	COPPER.	COBALT.	NICKEL.
	Per Cent.	Per Cent.	Per Cent.	Per Cent.	Per Cent.	Per Cent.	Per Cent.	Per Cent.
1	0.973	0.213	0.003	0.025	0.073	0.008	0.008	trace
2	0.886	0.196	0.002	0.037	0.185	0.006	0.018	0.021
3	0.694	0.128	trace	0.057	0.137	0.010	0.010	0.013
4	0.994	0.140	0.003	0.027	0.101	0.006	0.021	0.018
5	0.401	0.085	0.006	0.032	0.112	0.008	0.021	0.026
6	0.905	0.061	trace	0.026	0.108	0.004	0.016	0.018
7	0.915	0.191	0.002	0.026	0.086	0.002	0.018	0.013
8	0.238	0.105	0.012	0.034	0.184	0.022	0.016	0.021
9	0.463	0.121	0.002	0.020	trace	0.003	0.018	0.018
10	0.009	0.163	0.009	0.084	0.020	0.023	0.021	0.016

In this set, Nos. 3, 5, 8, 9 are mild steels, and No. 10 is an ingot iron. All are of fine quality, and have a good reputation in the market.

The steel-maker indicates the proportion of carbon contained in steel by designating its "*temper*," a term which must be carefully distinguished from the "*tempering*" of the tool-dresser and mechanic.

Seeböhm gives the following list of useful tempers for cast steel :

Razor Temper ($1\frac{1}{2}$ per cent. carbon). This steel is so easily burnt by being overheated, that it can only be placed in the hands of a very skillful workman. When properly treated, it will do twice the work of ordinary tool steel for turning chilled rolls, etc.

Saw-file Temper ($1\frac{3}{8}$ per cent. carbon) requires careful treatment, and, although it will stand more fire than the preceding temper, should not be heated above a cherry red.

Tool Temper ($1\frac{1}{4}$ per cent. carbon) is the most useful temper for turning tools, drills, and planing-machine tools, in the hands of ordinary workmen. It is possible to weld cast steel of this temper with care and skill.

Spindle Temper ($1\frac{1}{8}$ per cent. carbon) is a very useful temper for mill-picks, circular cutters, very large turning tools, taps, screwing dies, etc. It requires considerable care in welding.

Chisel Temper (1 per cent. carbon) is an extremely useful temper, combining great toughness in the unhardened state, with capacity of hardening at a low heat. It may also be welded without much difficulty, and is well adapted for tools where the unhardened part is required to bear the blow of a hammer without breaking but where a hard cutting edge is required, such as cold chisels, etc.

Set Temper ($\frac{7}{8}$ per cent. carbon). This temper is adapted for tools where the chief "punishment" is on the unhardened part, such as cold sets, which have to stand the blows of a very heavy hammer.

Die Temper ($\frac{3}{4}$ per cent. carbon) is the most suitable temper for tools, where the surface only is required to be hard, and where the capacity to withstand great pressure is of importance, such as stamping or pressing dies, boiler-cups, etc. Both the last two tempers may be easily welded by a mechanic accustomed to weld cast steel.*

179. The Pneumatic and Open-Hearth Processes are usually employed only in the manufacture of soft steels and ingot-irons; the latter is by far the most useful product.

A report to the Iron Office in Sweden contains the following analyses of Bessemer steels: †

Nos. 1 to 5 grade up from the softest ingot-iron to rather hard tool-steel; their analyses indicate excellent quality; they are "low" in phosphorus, free from sulphur, contain a little silicon, and a fair amount of manganese.

* Die-makers in the United States use the harder steels for much of their work.

† *Metallurgical Review*, 1877.

	C.	Si.	Mn.	P.	S.
1. Steel made from the blast furnace without addition of spiegeleisen, at Westanfors, Sweden.....	Per Cent. 0.085	Per Cent. 0.008	Per Cent. trace	Per Cent. 0.025	Per Cent. trace
2. " " " " " "	0.300	0.044	0.179	0.033	trace
3. " " " " " "	0.700	0.032	0.256	trace
4. " " " " " "	0.950	0.047	0.463	0.032	trace
5. " " " " " "	1.050	0.067	0.355	trace
6. Barrow-in-Furness—For coarse wire.....	0.200	0.179	0.214	0.026	0.030
7. Germany—For rail heads.....	0.128	0.306	0.386	0.034	0.040
8. " —For rails (from iron poor in manganese) ..	0.150	0.091	0.264	0.032	0.025
9. " —For rails (from mixture of Workington hematite and German manganese pig).....	0.046	0.634	0.638	0.093	0.045
10. Neuberg—For boiler plate direct from the blast furnace.....	0.250	0.016	0.136	0.010
11. " —Iron first remelted in cupola.....	0.300	0.056	0.273	0.041	0.040

Barrow ingot-iron, No. 6, is of acknowledged excellence, and the same may be said of the German and Austrian ingot-irons, which conclude the list.

Kerpeley gives the following analyses of different qualities of Bessemer steel rails:

	<i>a.</i>	<i>b.</i>	<i>c.</i>	<i>d.</i>	<i>e.</i>
Carbon.....	0.082	0.126	0.313	0.314	0.218
Silicon.....	0.902	0.452	0.078	0.047	0.068
Slag.....	0.016
Phosphorus.....	0.042	0.071	0.046	0.080
Sulphur.....	0.064	0.076	0.046	0.035
Copper.....	trace	trace	0.336	0.123
Manganese.....	1.277	0.851	0.515	0.165	0.317

Rails *a* were soft and bad, *b* were somewhat harder, while *c*, *d*, and *e* were hard, and of excellent quality. Kerpeley draws attention to the circumstance, shown by analyses *a* and *b* particularly, that manganese and silicon do not harden steel low in carbon, and that their hardening effect decreases, even if the percentage of both is high, as the quantities of both approach equality. As long as the percentage of silicon is not much more than one-half of that of manganese, the hardening effect of both is noticeable, provided the percentage of carbon does not fall below 0.15 per cent.

Rails made for the principal railroads of the U. S. are expected to contain, as maxima, Dr. Dudley's proportions:

Phosphorus.....	00.10
Silicon.....	00.04
Carbon.....	00.25 to 00.35
Manganese.....	00.30 to 00.40

Steels much higher in carbon have now been found satisfactory.

A Bessemer steel, made at Troy, N. Y., and analyzed by Blair, contained per cent.:

Carbon.	Silicon.	Sulphur.	Phosphorus.	Manganese.	Copper.
0.468	0.161	0.030	0.054	1.143	0.048

with minute quantities of cobalt and nickel.

Two samples of Martin "steel" (ingot-iron) made at Trenton, N. J., contained:

	Per Cent.	Per Cent.
Carbon ; combined.....	0.002	0.423
Carbon ; graphitic.....	0.046	0.042
Silicon.....	0.008	0.068
Sulphur.....	0.034	0.007
Phosphorus.....	0.130	0.068
Manganese.....	0.101	0.511
Copper.....	0.007	0.010
Cobalt.....	0.029	0.053
Nickel.....	0.047	0.052

A set of steels made by the same process by an American firm, noted for the excellence of its "steel boiler-plate," were found to contain (softest grades):

	A ₁	A ₂	B ₁	B ₂	C ₁	C ₂
Carbon ; combined.....	0.243	0.225	0.375	0.384	0.744	0.733
Carbon ; graphitic.....	0.011	0.019	0.012	0.012	0.012	0.017
Silicon.....	0.013	0.008	0.070	0.070	0.074	0.067
Sulphur.....	0.058	0.066	0.038	0.043	0.043	0.042
Phosphorus.....	0.128	0.132	0.092	0.094	0.104	0.107
Manganese.....	0.341	0.362	0.685	0.649	0.465	0.471
Copper.....	0.278	0.308	0.210	0.240	0.346	0.356
Cobalt.....	0.045	0.047	0.050	0.041	0.052	0.057
Nickel.....	0.065	0.057	0.115	0.105	0.120	0.135

180. **The Series of Changes** by which the ores of iron become first cast iron and then ingot-metal, by passing through first the blast furnace, and then the Bessemer converter, is well illustrated by the following analyses of Swedish ores and metals, as given by Ackerman :

The Iron Ores and Limestone employed at the charcoal-blast furnaces at Westanfors and Fagersta have the following composition :

	IRON-ORE FROM THE MINES OF—			LIMESTONE FROM HEDKÄRRA.
	Ostra Stor- tågten.	Granrot.	Gründal.	
Silica.....	27.49	3.10	6.35	10.82
Alumina.....	1.30	2.05	1.15	7.15
Lime.....	2.16	1.20	2.65	36.61
Magnesia.....	1.76	1.05	3.85	6.86
Protoxide of manganese .	0.81	10.40	5.50	1.25
Protoxide of iron.....	20.74	23.56	22.82
Sesquioxide of iron.....	46.14	52.44	50.78
Carbonic acid.....	6.10	5.95	37.18
Phosphoric acid.....	0.016	0.009	0.014	0.007
	100.426	99.909	99.064	99.877

These ores are mixed with the limestone, used as a flux, to form a charge—exclusive of fuel—having the following composition :

	Per Cent.
Silica.....	11.93
Alumina.....	2.50
Lime.....	7.51
Magnesia.....	2.76
Protoxide of manganese.....	5.63
Protoxide of iron.....	19.76
Sesquioxide of iron.....	43.89
Carbonic acid.....	6.02
Phosphoric acid.....	0.013

The yield of pig-iron is 48 or 50 per cent., and has an average constitution of :

Carbon, combined.....	3.460
Carbon, graphitic.....	1.289
Silicon.....	0.771
Manganese.....	4.491
Phosphorus.....	0.027
Sulphur.....	trace.

The slag from the blast-furnace has :

Silica	41.96
Alumina	7.02
Lime	25.04
Magnesia.....	17.75
Protoxide of manganese	6.57
Protoxide of iron.....	0.23
Alkalies	not determined.
	98.57

The iron tapped from the furnace is not made into pig, but is at once taken into the steel-works, and there converted by the pneumatic process into either ingot-iron or steel, of such grades as the market demands. No spiegeleisen, or "specular iron," such as may be used if desired in Swedish works for re-carburizing, is added in the case here described; but the "blow" is stopped when the carbon has been burnt out sufficiently. The ore and metal are so good that no red shortness is observable in the finished product, notwithstanding the entire disuse of its antidote—manganese.

The several standard grades of steel made as above gave the following analyses :

	CARBON.	SILICON.	MANGANESE.	PHOSPHORUS.	SULPHUR.
	Per Cent.	Per Cent.	Per Cent.	Per Cent.	
(a) Steel for soft plates, railway-axles, etc.....	0.085	0.008	trace	0.025	trace
(b) Steel for gun-barrels, shafts, etc.....	0.25	0.036	0.234	0.022	trace
(c) Soft steel for tools—saws, etc.....	0.70	0.032	0.256	0.023	trace
(d) Hard steel for tools—chisels, turning-tools, etc.	1.05	0.067	0.355	0.028	trace

181. The Reactions occurring in the Converter are

shown by a series of analyses made by King at the Bethlehem Iron Works, and reported to the American Institute of Mining Engineers.* The blow lasted 18 minutes. The converter had 12 tuyeres, each with 12 holes of $\frac{3}{8}$ -inch (0.95 centimetre) diameter. The number of revolutions of blowing engine 2 minutes after start was 38 per minute, with a pressure of $28\frac{1}{2}$ pounds (2 kilogrammes per square centimetre); 12 minutes after start, 43 per minute, pressure of $23\frac{1}{2}$ pounds (1.65 kilogrammes per square centimetre); and 15 minutes after start, 42 per minute. Eight samples of metal were taken, namely, one of the pig charged, three during the blow, one at the end of the blow, one of the spiegel, one of the final product, and one of the scrap charged before the addition of metal to the converter. Five corresponding samples of slag were also taken. The samples of metal were cast in small ingots, and borings were taken from different parts of these ingots by drilling, great care being taken that they were not much heated while being drilled. The slags were dumped at once from the small ladle into a can of water so as to cool rapidly, and they were then dried in a thermostat. The sampling was done with care, particles of ganister and shots of metal being separated from the slag. The elements to

ANALYSES OF BESSEMER METAL.

	I.	II.	III.	IV.	V.	VI.	VII.	VIII.
	Metal charged.	8 minutes after start.	15 minutes after start.	17 minutes after start.	18 minutes after start.	Spiegel.	Final product.	Scrap.
Specific gravity.....	6.866 6.818	7.4869	6.4476 6.20	7.369 7.114	6.7056 6.792	74.899	6.6907 6.459	7.541
Total carbon.....	3.543 3.500	3.199 3.231	1.230 1.270	0.2071 0.2069	0.0338 0.0340	4.338 4.396	0.367 0.374	0.2640 0.2643
Graphite.....	3.16 3.17	0.415 0.438	0.236 0.272	0.0297 0.0273	0.0095 0.0094	0.824 0.827	0.0187 0.0188	0.01493 0.01463
Combined carbon.....	0.383 0.390	2.784 2.783	0.995 0.999	0.1775 0.1797	9.0245 0.0246	3.569 3.514	0.349 0.356	0.2491 0.2497
Silicon.....	2.384 2.398	1.07 1.10	0.108 0.107	0.058 0.050	0.0369 0.0429	0.66 0.67 0.68	0.06015 0.06085	0.103 0.117
Manganese.....	0.4956 0.4913	0.1511 0.1504	0.133 0.134	0.129 0.130	0.097 0.105	16.12899 16.15689	1.17498 1.16610	1.2293 1.2123
Phosphorus.....	0.089	0.092	0.0761	0.069(?)	0.0897

* Transactions 1880.

which attention was especially directed were graphitic and combined carbon, manganese, and silicon. The results, which are given below, are similar to those obtained by others where the charges are manganese.

The results of the analyses of the slags are as follows:

ANALYSES OF SLAGS.

	I.	II.	III.	IV.	V.
	8 minutes after start.	15 minutes after start.	17 minutes after start.	18 minutes after start.	After addi- tion of spie- gel.
Specific gravity.....	2.979	2.282	2.411	2.937	2.770
Silica	62.656	73.214	75.604	61.293	64.143
	62.641	73.260	75.668	61.300	64.165
Alumina and phosphoric acid.	7.984	4.512	5.203	4.217	5.661
	7.985	4.515	5.186	4.267	5.761
Ferrous oxide.....	1.066	none.	none.	13.506	14.007
	1.890			13.446	13.892
Manganous oxide.....	15.789	11.839	10.922	10.863	12.813
	15.773	11.824	10.921	10.787	12.807
Lime	0.659	1.110	0.960	0.747	0.745
	0.653		0.040		0.740
Magnesia.....	0.444	0.641	0.399	0.288	0.244
	0.518		0.360		0.234
Metallic iron.....	10.502	8.724	7.717	9.086	2.387
	10.540	8.712	7.693	9.165	2.401

The conclusions to be drawn from the above analyses are:

1. Phosphorus is not eliminated where a silicious lining is used, but the proportion is slightly increased, owing to the diminution of weight of the charge of metal.

2. Graphitic carbon is converted into combined carbon, during the first period of the blow, by the elimination of the silicon, the total carbon remaining about the same. In the second period the total carbon is rapidly eliminated.

3. Silicon is oxidized during the first and second periods, at the conclusion of which it is nearly all oxidized.

4. Manganese decreases rapidly during the first period, and more gradually during the remainder of the blow.

5. By the addition of the spiegel the manganese, carbon, and silicon are increased in the metal, and the iron in the slags is decreased.

6. The final slag carries the silicon and manganese of the charge, and contains 25.56 per cent. of iron.

7. The first period, of eight minutes, is characterized by a low temperature, during which the silicon and manganese are oxidized; the second period of nine minutes, or "boil," is marked by a high temperature, during which the carbon is oxidized rapidly; and the third period, or last minute of blow, by the rapid oxidation of the iron.

The following table indicates the variety and the quality of the ores sometimes used by Bessemer steel manufacturers:

BESSEMER ORE ANALYSES.

NAME.	LOCATION.	CONTENTS.			
		Iron.	Mn.	Phos.	Ins. Matter.
Pilot Knob.	Missouri	60.272	0.017	12.936
Palomares.	Spain.....	47.028	12.433	0.028	2.200
Kloman...	Lake Superior.....	63.42	0.155
McComber.	".....	52.671	2.597	0.029	12.700
Lowell.....	Menominee Range.	55.36	0.017	15.55
Almeria.....	Spain.....	53.01	6.333	0.01	3.07
Champion..	Lake Superior.....	66.45	0.039	2.80
Curry.....	Menominee Range.	61.813	0.024	6.176
Carthagea	Spain.....	27.378	22.890	0.017	6.200
Tapra.....	Algeria	62.162	0.507	0.053	1.970
Republic...	Lake Superior.....	68.376	0.043	1.800
Manganese.	Virginia.....	6.971	41.320	0.156	13.316

182. Chrome Steels made at Brooklyn, N. Y., under the direction of Mr. Baur, the patentee, contained

	No. 1.	No. 2.	No. 3.
Carbon, combined.....	0.627	0.439	0.461
Carbon, graphitic.....	0.012	0.015	0.000
Silicon.....	0.154	0.136	0.116
Sulphur.....	trace	0.001	trace
Phosphorus.....	0.007	0.019	0.020
Manganese.....	0.050	0.023	0.027
Copper.....	0.008	0.000	trace
Chromium.....	1.044	0.921	0.612

These steels are peculiar in composition as well as in structure and behavior when worked. Their peculiarities consist not only in the presence of chromium, but in the absence of manganese. They contain carbon with nearly the same variation of proportion as chromium, and their character must be evidently dependent upon the combined influence of both elements.

The Author has met with no complete analyses of *Tungsten Steel*. Such samples as have been examined are reported to contain from 1 to 3 per cent. tungsten, and tests of their tenacity indicate 25 per cent. greater strength in some cases than that of carbon tool steels with which they were compared.* A good ordnance metal contained: † Tungsten, 0.3 per cent.; Carbon, 0.52; Silicon, 0.04; Sulphur, 0.005; Phosphorus, 0.04; and had a strength of 77 tons per square inch (12,125 kilogrammes per square centimetre).

Phosphorus Steels are properly common steels in which the other hardening elements are reduced to a minimum. Euverte, studying such steels (ingot-irons) at Terre-noire, concludes:

(1.) It is desirable, in order to obtain phosphoretted steel of suitable quality, not to exceed 0.3 to 0.35 per cent. of phosphorus; and in order that even this proportion may be admissible, the carbon must not exceed 0.15 to 0.18 per cent.

(2.) The presence of silicon must be avoided as far as possible. Manganese does not, however, appear to be objectionable; and it would even seem that a proportion, in the steel, of 0.4 to 0.6 per cent. is favorable to the quality.

(3.) To obtain good steels, of this kind, it is indispensable to employ the Siemens-Martin process of fusion, taking as point of departure those varieties of cast iron that are not siliceous, and that contain the smallest possible proportion of carbon.

(4.) A very small percentage of carbon being one of the essential conditions of success in the operation, carbon must not be added in any form; and the process should be finished

* Percy, p. 294.

† Jeans, p. 531.

by the addition of ferro-manganese, as rich as possible. The alloy containing 60 to 64 per cent. of manganese, now regularly made at Terre-noire, appears to be indispensable in obtaining the results of which particulars have been given above.

(5.) These various conditions being fulfilled, it appears evident that rails of metal containing above 0.3 per cent. of phosphorus may be made that will fulfill, in the most satisfactory manner, all the conditions of resistance that may be reasonably required of a good steel rail.

(6.) It has been shown, by precise and repeated experiments, that the metal becomes more resisting in proportion as it has been subjected to a greater amount of mechanical work.

(7.) It is important, for this reason, that the metal should be cast into ingots as large as possible, in proportion to the final section to be produced; and, further, it should be worked at as low a temperature as possible, in order, at the same time, to subject it to a greater amount of mechanical work, and to avoid the deterioration which is inevitably produced in working it at a somewhat high heat.

183. Influence of Composition on Welding Quality.—The work of the Committee on Chain Cables of the United States Board Appointed to Test Iron, Steel, etc., has revealed many valuable facts, and their conclusions may be stated in brief:

“1st. That any wrought iron, of whatever ordinary composition, may be welded to itself in an oxidizing atmosphere at a certain temperature, which may differ very largely from that one which is vaguely known as a ‘welding heat.’

“2d. That in a non-oxidizing atmosphere, heterogeneous irons, however impure, may be soundly welded at indefinitely high temperatures.

“Irons in which there is much carbon require to be welded at a very low heat; phosphorus in excess calls for the same. Coarse iron with much slag requires a high heat and hard hammering, and even then there is a liability for ‘faces’ to form throughout the whole surface of the lap, which faces

simply stick together, and are liable to draw. A very close, fibrous iron also requires a high heat and hard, rapid hammering; the reason for which is that the heavy blows previously required to make the scarf or lap have so amalgamated the fibres one with another that when the two laps are brought into contact the fibres of each do not intermingle thoroughly, and they, too, are frequently simply stuck together, adhesion taking the place of a process similar to felting, which occurs in welding an iron with a rather open fibre. With this a low heat is required, which seems to penetrate and expand the fibres so that they intermingle, and the two laps are held together by a net-work. Moderate hammering is necessary with this type of iron, which is seldom found to possess great tensile strength, but nearly always has great resilience.

“An iron in which sulphur is in excess can be bent and welded at a high heat, but the more moderate heat at which the bend and scarf are usually made is trying to it, and ‘*red-short links*’ are frequently cracked in bending.

“All the irons tested were so low in sulphur that this ingredient could not have materially affected welding power.

“The irregular differences in the working and reduction of the bars which affected all other physical properties, affected this property also.

“The $1\frac{1}{4}$ -inch bar of iron, E, presents an exception; it stands high on the list in welding capacity, and contains copper 0.31 (average Cu. in iron E, 0.34). Its phosphorus, slag and silicon are about average. But the bar is also remarkable in containing nickel 0.35, and cobalt 0.11. No other irons contain any notable amount of them, except iron M, which has Co. .07, and Ni. .08; but it also has Cu. 0.17 per cent.* The welds of this iron were very strong, the links breaking oftener at the butt than at the weld.

“Two links made from iron E† were analyzed from speci-

* This iron may have received the copper while being rolled in a train ordinarily used for copper at the Navy Yard, Washington, D. C., where it was manufactured.

† The letters here given are those of the same irons under a different nomenclature from that adopted by the Board as shown later.

mens taken at the weld end and at the butt end. The weld end had been reheated and hammered twice; the butt end had not been hammered, and had received second heat only by conduction from the other end. The analyses show that silicon and slag only were materially affected by twice heating and hammering, as follows:

	Si.	Slag.
" 1½-inch bar, weld end	0.182	0.998
1½-inch bar, butt end	0.203	1.074
1¾-inch bar, weld end	0.177	1.388
1¾-inch bar, butt end	0.261	1.732

" In oxidizing to silica the Si. introduced a small amount of flux which should have aided welding by preventing oxidation or by carrying off oxide of iron; but the amount was so very small in this case that its effect cannot be traced. Nor does iron N, in which Si. was highest (0.18 to 0.32), confirm this notion. Although the other impurities were not high, and the iron was not overworked, it welded badly.

" Phosphorus, up to the limit of ¼ per cent., had not a notable effect on welding. It was lowest in iron P, which welded soundly, but all impurities were low, and welding power was traced to the reduction of the bar by direct experiment. The same is true of iron P. Omitting one course of piling and hammering largely helped its welding power. Iron F welded badly, not necessarily on account of its P. 0.25; for iron L, with P. 0.23, and iron C, with P. 0.18, welded soundly. Iron E had high P., 0.23 (0.21 to 0.32). While its surfaces unite well, the links broke through the weld when they were made at a high heat, which may be accounted for by the fact that phosphorus increases fluidity, and hence capacity for oxidation. The value of short chains is in the following order: P. 0.23, 0.18, 0.07, 0.09, 0.20, 0.20, 0.19, 0.17, 0.19, 0.25, 0.19, 0.22, 0.15.

" Carbon notably affected welding. It ran as follows, in connection with regularly decreasing welding power: C. 0.015, 0.002, 0.043, 0.066, 0.026, 0.032, 0.032, 0.042, 0.055, 0.033, 0.032, 0.0044, 0.68, and, including A, 0.351.

" The weld-steel, or steely-iron, A (C. 0.035), when treated

by the uniform method usually adopted for chain-cable irons, made the worst welds. Iron B, with carbon so low as 0.07, made bad welds, although it was otherwise a good average chain-iron, with a medium amount of impurity. Carbon, in a greater degree than phosphorus, promotes fluidity, hence the iron is 'burned' at the ordinary welding temperatures of low-carbon irons.

"Slag was highest (2.26 per cent.) in the 2-inch bar of iron J, which welded less soundly than any other bar of the same iron, and below average as compared with the other irons. Slag should theoretically improve welding, like any flux, but its effects in these experiments could not be definitely traced.

"The want of uniformity in the chemical composition of the *same brand of iron*, is a conspicuous defect which is readily accounted for. In iron E, silicon varied from 0.16 to 0.26; in iron N, it varied from 0.18 to 0.32; in iron C, phosphorus varied from 0.12 to 0.24; and in iron N, from 0.14 to 0.29.

"Starting with a uniform pig iron, the puddling process may or may not remove a large amount of silicon, phosphorus and carbon, according to the temperature and agitation of the bath, the 'fix' used in the furnace, etc.

"Both iron and steel have been so perfectly united that the seam could not be discovered, and the strength was as great as it was at any point, by accurately planing and thoroughly cleaning the surfaces, binding the two pieces together, subjecting them to a welding heat, and pressing them together by a few blows. But when the thinnest film of oxide of iron was placed between similar smooth surfaces a weld could not be effected.

"Heterogeneous steel-scrap, having a much larger variation in composition than any irons, placed in a box composed of wrought-iron side and end pieces laid together, is, on a commercial scale, heated to the high temperature which the wrought iron will stand, and then rolled into bars which are more homogeneous than ordinary wrought iron. The wrought-iron box so settles together, as the heat increases, that it

nearly excludes the oxidizing atmosphere of the furnace, and no film of oxide of iron is interposed between the surfaces. At the same time the inclosed and more fusible steel is partially melted, so that the impurities are partly forced out and partly diffused throughout the mass."

184. Conclusions from Comparison of Chemical and Physical Tests.—(1.) Although most of the irons under consideration are much alike in composition, the hardening effects of phosphorus and silicon can be traced, and that of carbon is very obvious. Phosphorus up to 0.10 per cent. does not harm, and probably improves, irons containing silicon not above 0.15 and carbon not above 0.03. None of the ingredients, except carbon, in the proportions present, seem to very notably affect welding by ordinary methods.

(2.) The strength of wrought iron and its welding power by ordinary methods are varied more by the amount of its reduction in rolling than by its ordinary differences in composition. Uniform strength may be promoted by uniform reduction, but only at such increased cost of manufacture that the practice is not likely to obtain. Therefore, the reduced strength of large bars made by ordinary methods should be considered in designing machinery and structures.

(3.) The U. S. Board has demonstrated that the tenacity of 2-inch bar iron, as customarily made for chain-cable, should be between 48,000 and 52,000 pounds per square inch, and of 1-inch bar between 53,000 and 57,000 pounds, and that stronger irons than these make worse cables because they have low ductility and welding power.

(4.) Chemical analyses, made in connection with physical tests, are indispensable to conclusions about either the character or treatment of iron.

(5.) Analyses prove that the same brand of wrought iron may be heterogeneous in composition, and they emphasize the previously known fact that wrought-iron-making processes, as compared with the cheap steel processes, necessarily give an uncertain character to the former material, while to the latter the desired quality may be imparted with certainty and uniformity.

(6.) The ordinary practice of welding is capable of radical improvement. The perfection of means for welding in a non-oxidizing atmosphere would seem to be the promising direction of improvement.

185. The Physical Properties of Iron vary with its chemical composition, and through an immensely extended range of quality. The strength, elasticity, and ductility of iron and steel will be considered in another chapter; we have here to refer only to those more purely physical properties which are not usually considered of such direct and general importance in engineering work.

As has been seen, and as will be noted by the reader of the reports of metallurgical chemists, cast iron contains, usually, in its several grades :

	Per Cent
Carbon.....	2.25 to 5.5
Silicon	0.15 to 5.5
Manganese.....	0.00 to 3.0
Sulphur.....	0.00 to 1.0
Phosphorus.....	0.00 to 1.5

Wrought iron and steel contain from one-tenth to one-fourth these proportions. With every change in absolute, and with all changes of relative proportions of alloying substances, the physical properties of these metals undergo greater or less change, and it is only when the exact chemical constitution of the metals, and the method and extent to which they have been worked are known, that the skillful metallurgist or engineer can confidently say what is the quality of the metal, and what will be found to be its peculiarities. Conversely, knowing the character of the work to be done, and the method by which the material is to be subjected to strain, or to physical or chemical action, he can so write his specifications as to secure the metal best adapted to the proposed purpose.

Pure Iron, as has been stated, is almost unknown. Those specimens produced in the chemical laboratory by chemical reactions, or by electrolysis, are described as silver-white, very ductile and malleable, softer than any commercial iron, but breaking with either a granular or a crystalline fracture.

Its specific gravity is given at 8.13 to 8.14, and after remelting about 7.85.

Iron crystallizes in the cubical system, when subjected to long continued heat and, perhaps, to jarring. It has a fusing point at not far from 3,632° Fahr. (2,000° Cent.), and has been volatilized, according to Elsner,* at a temperature of about 5,432° Fahr. (3,000° Cent.).

Commercial Malleable or Wrought Iron (weld-iron) has a specific gravity of from 7.5 to 7.8, determined by its chemical composition and physical structure. Its specific heat is given by Regnault at 0.113795, and it is said to increase slightly with increase in carbon; it conducts heat at a rate, according to Despretz, of 0.3743, the conductivity of gold being taken as unity.

Its linear expansion may be taken at .0000677 per degree Fahr., or .000012 per degree Cent. It expands, between ordinary temperatures and a white heat, about 0.013, and about 0.008 between a red and a white heat. Its melting point is lowered, as the proportion of carbon and other foreign elements increase.

The Electric Conductivity of good iron is given at from 0.15 to 0.20, copper being 1. It is strongly affected by the magnet, and its magnetic power is reduced, but is rendered more permanent, by the addition of carbon; it loses magnetic power with increasing temperature, its magnetism vanishing at a bright red or a white heat.

The Hardness of Iron increases with the addition of carbon, manganese, chromium, or phosphorus. Pure iron is probably too soft to be of value in the arts. Its tenacity increases with the addition of hardening elements, and is reduced by elevation of temperature; after passing through the pasty, or welding temperature, it becomes liquid.

Malleability and Tenacity are usually affected in opposite ways by the addition of foreign elements to pure iron; both will vary, but not in the same ratio in all cases; carbon reduces the malleability to a less extent for a given increase

* *Les Mondes*, 1873, p. 404.

of tenacity than any other of the elements usually found in iron or steel; except, perhaps, manganese in small doses, which is said not to seriously reduce malleability. Ductility is affected in the same manner as malleability. Increase of temperature increases both the latter qualities.

With some irons, heating to a red heat and suddenly cooling in water causes hardening; but the best grades either undergo no change, or perceptibly soften when so treated. The ingot-irons—"mild steels"—are thus softened if of the quality considered best for use in boiler-plate, or for bridges and similar purposes.

The Texture of Iron varies greatly with its treatment. Ingots of either iron or steel are often of crystalline or granular structure, but both acquire a fine grain, and iron takes a silky, fibrous texture when well worked under the hammer or in the rolls. The granular and sometimes the crystalline character reappears after prolonged cold-hammering, or often after repeated heavy shocks.

186. Cast Iron has a specific gravity of 7.00 to 7.60, averaging 7.25 or 7.30 for the finest grades of ordnance-iron and engine castings. Good cast iron melts at about $2,732^{\circ}$ Fahr. ($1,500^{\circ}$ Cent.), but the fusing point varies with variations of composition. White iron passes through a semi-fluid condition at the melting-point, and only flows freely at a considerably higher temperature; it is easily chilled by sudden cooling, and, when slowly cooled, usually becomes more gray as the cooling is more retarded. On the other hand, a gray iron may in some cases become nearly white on being suddenly cooled.

The specific heat of gray iron averages 0.13983, according to Regnault, and that of white iron 0.12728. Cast iron expands more than wrought iron, and the pattern makers' rule allows a "shrink" of one-eighth inch to the foot (1 centimetre per metre) in cooling from the temperature of solidification to that of the atmosphere. Rinman found the shrinkage to be 0.013 from the red heat, and 0.020 from a white heat.

Cast iron, on the whole, contracts on solidifying, but, at

the moment of solidification, a slight expansion takes place which causes it to "set" in contact with the mould, and it thus makes good castings.

Guettier* gives the following figures for cast iron :

	S. G.	COEFF. OF EXPANSION.
Dark Foundry Iron.....	6.80	0.001111 Roy.
Gray " "	7.20	0.001182 Dulong.
Mottled Cast "	7.35	<i>Specific Heat.</i>
White " "	7.60	0.12893 Regnault.
Very white iron	7.80	0.1400 Pouillet.

187. Steel of good quality has a grayish white color, approaching in the finer grades a silver white, and has a lustre which is superior to that of the cruder sorts of wrought iron, but not to that of the finest grades; it retains its polish much better than iron. In hardness the true steels are superior to all ordinary grades of iron, but some chilled cast irons and some kinds of white iron will cut substances that resist the hardest steels. The strength of steel is greater than that of iron, and, within usual commercial limits, is the higher as the proportion of hardening elements is greater. It is of comparatively low ductility and malleability, but it can be forged, and all but the hardest grades of the tool steels can be welded by an expert workman. It becomes quite soft at a high heat, and can then be easily forged, but is liable to lose quality in the operation. Its specific gravity varies from 7.55 to 7.8. Steel melts at a higher temperature than cast iron, but less than malleable iron, and its fusion point may be taken at 3,272° Fahr. (1,800° Cent.) for tool steels, though variable with the proportion of carbon and other elements present. Its specific heat is given by Regnault as 0.11840; its extension is about 0.010 when raised to the red heat, and 0.012 at a white heat. Its electric conductivity is nearly that of iron. The magnetism of tool steel is very permanent.

Tempering is a process which gives steel any desired degree

* *L'emploi de la Fonte de Fer* ; Paris, 1861.

of hardness, and the power of accepting this change of physical condition is the most valuable property of steel, and constitutes its distinguishing peculiarity. Sudden cooling from a high heat hardens, and slow cooling softens, this remarkable metal. The tool maker or tool dresser, by adopting the one or the other or both of these methods in succession, is able to secure any temper that he desires.

The hardening liquid is usually either water or oil, but solutions, as of salt in water, and other liquids, as mercury, are sometimes used. The same liquid will produce different effects at different temperatures either of the fluid or of the steel. When highly heated and plunged into cold mercury, good tool steel becomes exceedingly hard, and will cut nearly all known substances. At moderate heats the Author has found steel both strengthened and toughened by mercury also. Heated to a lower temperature and plunged into a hot oil-bath, it is not made much softer, but is greatly strengthened and toughened. See Art. 189.

188. The Working of Tool-Steel involves, usually, forging, hardening and tempering, to obtain a certain well determined hardness and temper. "Hardening" is a process of sudden cooling which results in the production of so great a degree of hardness that some method of softening to the desired temper must usually be practiced, to give the tool or other piece of steel the quality or "temper" demanded. This second process is known as that of "tempering." It is sometimes possible to temper without prior hardening.

The effect of hardening is well illustrated by an experiment devised by Metcalf.*

A small bar of tool-steel is nicked deeply at intervals of three-fourths of an inch or an inch (1.9 to 2.54 centimetres) for a length of 6 or 8 inches (15 to 20 centimetres). The bar is heated in such a manner that the extremity shall be white-hot, and the heat gradually reduced along the bar until, at the other end of the nicked part, the steel is below the red heat; then, numbering the pieces, as in the illustration, from

* *Metallurgical Review*, 1877.

1 to 8, beginning at the white-hot end, No. 1 will be white-hot and scintillating; No. 2 white-hot; No. 3 bright yellow; No. 4

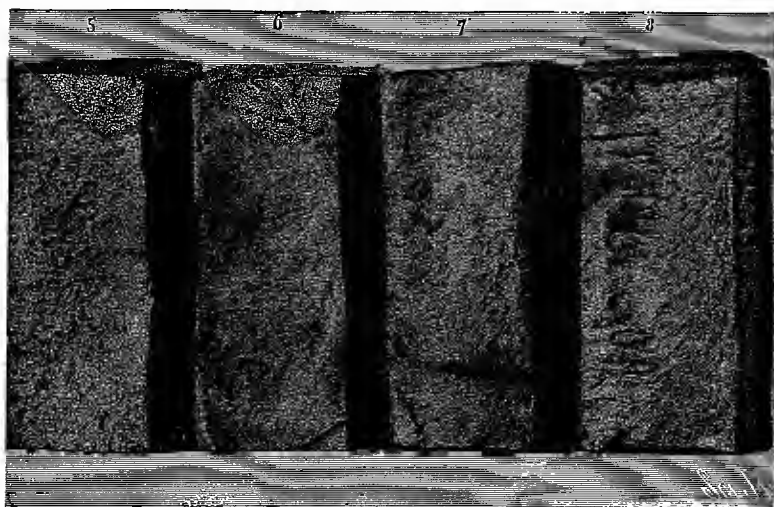
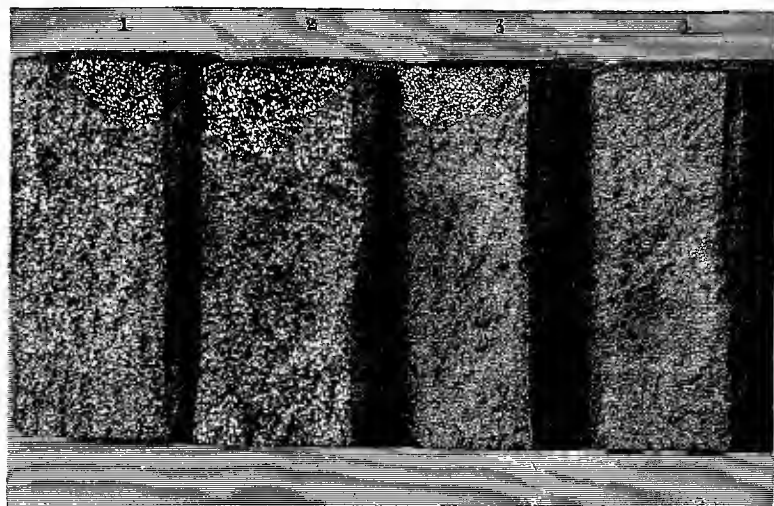

FIG. 58.—GRAIN OF STEEL.

low yellow, or orange; No. 5 bright red; No. 6 dull red; No. 7 a low red heat; and No. 8 will be a black heat. Quenching in water and cooling thoroughly, and then trying the several pieces with a file, No. 1 will be found too hard to cut, and will scratch glass; Nos. 2, 3 and 4 will be very hard; 5 and 6 quite hard enough for any ordinary tools; No. 7 hard enough to "tap steel;" and No. 8 will be unhardened, the hardening temper being, according to the observations of the Author, above 932° Fahr. (500° Cent.). Breaking up the bar, No. 1 will be found as brittle as glass or quartz; No. 2 nearly as brittle; Nos. 3, 4 and 5 each a little less brittle, and a little tougher and stronger, as the number is higher; Nos. 6 and 7 will be tough and very much stronger than No. 8 and the unheated bar, which retain all their original toughness.

In texture and color No. 1 will be coarse, yellowish, and very lustrous; No. 2 will be coarse and not quite so yellow as No. 1; No. 3 will be finer than 1 or 2, and coarser than No. 8, and will have a "fiery" lustre; No. 4, like No. 3, not quite so coarse, yet coarser than No. 8; No. 5 will be about the same size grain as No. 8, but will have "fiery" lustre; No. 6 will be much finer than No. 8, will have no "fiery" lustre, will be hard through, and very strong. This exhibits the "refining" by hardening. No. 7 will be refined and hard on the corners and edges, and rather coarser, and not quite as hard in the middle, and about the right heat for hardening taps, and milling tools, the teeth of which will be amply hard, while there will be no danger of cracking the tool. No. 8 exhibits the original grain of the bar.

A crack, as seen in No. 4, usually extends along to the refined piece, but rarely, if ever, beyond it. The investigator concludes:

(1.) Any difference in temperature sufficiently great to be seen by the color, will cause a corresponding difference in the grain. This variation in grain will produce internal strains and cracks.

(2.) Any temperature so high as to open the grain so that the hardened piece will be coarser than the original bar, will

cause the hardened piece to be brittle, and liable to crack and crumble on the edges in use.

(3.) A temperature high enough to cause a piece to harden through, but not high enough to open the grain, will cause the piece to "refine," to be stronger than the untempered bar, and to carry a tough, keen, cutting edge.

(4.) A temperature which will harden and refine the corners and edges of a bar but which will not harden the bar through, is just the right heat at which to harden taps, rose-bitts, and complicated cutters of any shape, as it will harden the teeth sufficiently without risk of cracking, and will leave the mass of the tool soft and tough, so that it can yield a little to pressure, and thus prevent the teeth tearing out. These four rules are general, and apply equally well to any quality of steel or to any temper of steel.

(5.) Steel that is so mild that it will not harden in the ordinary acceptance of the term, will show differences of grain corresponding to variations in temperature.

To restore any of the first seven pieces shown in Fig. 58 to the original structure as shown in the last, it is only necessary to heat it through to a good red heat, not to a high red, allow it to stay at this temperature for ten minutes to thirty minutes, according to the size of the piece, and then to cool slowly. If upon the first trial the restoration should be found incomplete, and the piece, upon being fractured, should still show some fiery grains, a second heating, continued a little longer than the first, would cause a restoration of structure. This property of restoration is not peculiar to any steel. A piece restored from overheating, is never quite as good as it would have remained if it had never been abused; and no occasion should ever be given for the use of this process of restoration except as an interesting experiment. The original and proper strength of fine steel can never be fully restored after it has once been destroyed by overheating.

A set of six samples treated as above were examined by Langley, and their densities compared with those of untreated bars from the same ingots. The samples were from the set

numbered 1 to 12, in Art. 178. The results were thus shown:*

	1	2	3	4	5	6	7	8	9	10	11	12
Ingot density.....	7.855	7.836	7.841	7.829	7.838	7.824	7.819	7.818	7.813	7.000	7.803	7.805
Ingot carbon.....	0.302	0.490	0.589	0.649	0.801	0.841	0.867	0.871	0.955	1.007	1.058	1.079
Order of samples from bar
S. G. Burned 1.....	7.818	7.791	7.789	7.752	7.744	7.69a
2.....	7.814	7.811	7.784	7.755	7.749	7.741
3.....	7.823	7.830	7.780	7.758	7.755	7.769
4.....	7.826	7.84d	7.808	7.773	7.789	7.798
5.....	7.831	7.806	7.812	7.790	7.812	7.811
Cold 6.....	7.844	7.824	7.829	7.825	7.826	7.825

The density decreases in the unheated bar from 7.855 to 7.805, as the carbon increases from 0.302 to 1.079. It decreases with the increase in hardness in each sample, and the change is greatest with the steel containing most carbon; it consequently happens that hard steels are much more liable to crack and warp, or twist in hardening, than softer grades; the coefficient of expansion is also less for soft than for hard steels.

Repeated hardening, even from a very low temperature, increases still further the volume of the steel, with corresponding reduction of density.

A high heat may be permitted in working steel where hardening or tempering is not to follow, as it will forge well, unless very hard, and, if quickly handled, need not be perceptibly injured. Long exposure to a high temperature is liable to injure it by giving it a coarse grain, and by causing loss of carbon.

Steel should usually, and especially when it is to be tempered, be worked at a moderate temperature, should be very uniformly heated, and should be worked rapidly. "Soaking" in the fire may cause serious loss of quality.

The fire should be clean, heavy, and just hot enough to heat rapidly without burning or softening the edges and corners of the steel; it should have a deoxidizing flame. Welding can be best done by using melted and ground borax as a flux, and the forging should be so conducted as to refine

* *American Chemist*, Nov., 1876.

the steel, and to leave the edges and corners sharp and sound.

When hardening, a very uniform heat is required for pieces of uniform section, and higher heat is necessary as the size of its section increases; but this difference should not be great, and it should be very carefully graded, as a high heat produces a coarse, open grain, and irregularity of heating is likely to cause cracking from internal strain. Cooling should be moderately rapid, complete, and perfectly regular. The bath should be large, and supplied with running water when large pieces are to be hardened. Tempering should be done very carefully, and the cooling should take place slowly and very regularly throughout the piece. The lowest heat at which the steel will harden is best. Hot steel, if not intended to be tempered, should always be cooled slowly, and in a dry place of uniform temperature. When annealing, heating slowly to a low heat, and cooling in ashes or other non-conducting material, gives the best results.

Pieces of very small section are sometimes tempered by contact with a smooth surface of cold metal; they may be annealed by cooling slowly in contact with, and simultaneously with, a larger mass of heated iron. Charcoal is the best fuel for use in working steel, and coke is better than coal.

To prevent loss of carbon, small articles are often covered with a flux having carbonizing or deoxidizing properties.

The edge of steel tools cutting hard alloys or steels may be held often by lubrication with petroleum.

189. In Drawing the Temper, the hardened steel is usually reheated until the scale of oxide on the surface assumes a certain color; which color indicates a certain temperature which is constant, or nearly so, for any one steel, and is slightly different for different steels. The colors and the tempers so obtained are usually given as on page 324.

According to De Bonneville,* in hardening springs, those of light wire, or long in proportion to their diameter, should be placed on a mandrel fitting loosely, and heated while on

* *Van Nostrand's Magazine*, 1878; p. 391, *et seq.*

TEMPERATURE.		COLOR.	USE.
Cent.	Fahr.		
220°	428°	Pale yellow.	Surgical instruments.
230	446	Straw.	Penknives, razors ; wood-tools.
255	491	Brown-yellow.	Chisels and scissors.
265	509	Purplish.	Axes ; heavy knives.
275	527	Purple.	Table knives ; springs.
290	534	Pale blue.	Watch-springs ; swords.
295	563	Dark blue.	Fine saws, drills.
315	600	Very dark blue.	Hand-saws.
350	662	{ Very dark blue, verging on green. }	{ Too soft for any ordinary tools.

it to prevent bending and disarrangement of the coils during the heating process. The fire should be clear, of green coal ; sometimes a fire is built around a piece of gas pipe, with the spring inserted ; this causes the spring to be uniformly heated. Being heated to a cherry red, the spring must be plunged into clear water slightly heated, and held there till quite cold.

If it is then found black and if not evenly mottled with white spots, it would indicate an insufficient hardness arising from the quality of the steel or insufficient heating ; steel, when of good quality, is sufficiently heated when it just forms a scale on coming from the fire.

If the hardening process is found difficult, the water should be salted till it becomes a strong brine, and the hardening repeated till the steel appears white when taken out of the water, as it will if well hardened ; the whiteness of the surface being a better test than the file would be, because steel of a straw color will not file, and any degree of hardness between straw color and white cannot be distinguished by this test.

The temper of a spring lowered from a white hardness to a blue, is not the same as that lowered from a black or even a mottled hardness to a blue ; and hence, for the sake of evenness in the temper, all those of a dark or mottled appearance should be reheated.

The most reliable method of tempering an ordinary spring, is to "blaze it off ;" *i. e.*, boil it off in the oil, heating and reheating the oil to a blaze, and dipping and redipping it in two or three times ; after the boiling and the blazing takes

place freely all over the spring, and has, on the last removal from the tank, burned out at any one point, it should be placed in warm water and left to cool.

The thicker the spring, the longer it should be subjected to this process of blazing and dipping, so that every part of the spring shall be equally heated inside and out. It is well that the spring should be reversed and revolved in the oil, in order that heat may not accumulate at any one point, and thus make an uneven temper. A good oil composition for hardening consists of :

Spermaceti oil	48	parts.
Neats'-foot oil.....	47	"
Rendered beef suet.....	4	"
Resin	1	"

The tank in which it is placed should have a close-fitting cover, which will put out the blaze when the tempering is finished.

The colors adopted are not invariable for even the same purposes ; different makers temper their tools somewhat differently. Watchmakers' tools are heated in the flame of a blow-pipe or of a lamp, and are hardened either in the air, or by plunging their points into wax or tallow. Saws and springs are often hardened in mixtures of wax and oil, tallow or suet ; the tempering is done by "blazing off" the grease. Car-springs and carriage springs are heated to a low red heat, cooled in hot or in warm oil, and left without further tempering. Large pieces must be "drawn" more in tempering than small ones. The peculiar steels mentioned in Art. 182 require a very different treatment from the carbon steels.

Chrome steel may be forged like any other, but all tools drawn from a large body to an edge should be allowed to cool off after forging, and should be reheated for tempering, as the interior of the mass retains the heat at which it was forged long after the external surface has cooled. It is still too hot for tempering, and is liable to crack on cooling.

The following table shows more generally the proper treat-

ment of tool-steels in tempering for various purposes, water being used in cooling :

TABLE XL.
SCALE FOR TEMPERING TOOLS OF CARBON STEEL.

MATERIAL CUT.	TOOLS URGED BY—										NOMENCLATURE.
	PRESSURE.					IMPACT.					
	A	B	C	D	E	F	G	H	K		
Unannealed Steel.	0	1	2	2	3	4	2	2	7		0. To remain as dipped.
Annealed Steel.	1	2	2	3	3	5	3				1. Light straw color. 2. Dark straw color.
Chilled Cast iron.	0	0									3. Orange color. 4. Reddish purple color.
Hard Cast iron.	0	2	3	3	4	2					5. Purple color. 6. Bluish purple color.
Soft Cast iron.	1	3	3	3	5	3					7. Dark blue color. 8. Light blue color.
Gun Metal (Bronze).	1	2	3	3	6	6					9. Bluish gray color. 10. Soft.
Yellow Brass.	2	3	3	3	6	6					A. Turning or planing tools.
Soft composition.	3	4	3	3	7	7					B. Drills, bits. C. Taps, dies.
Wrought Iron.	3	6	3	3	7	7	4				D. Rimmers. E. Cold chisels.
Copper.	4	6	3	3	7	7	4				F. Flogging chisels. G. Caulking tools.
Wood.	6	6									H. Hammers. K. Springs.

Chrome steels, and also the wolfram steels, should be hardened at the lowest heat possible—a dark cherry red, seen only in the shade—and they will then be found to have maxi-

imum strength and hardness. The temper is not "drawn" for ordinary tools. Pieces of small size, or having thin edges, are slightly drawn in temper at the edge or point. Too great heat causes the grain to become coarse and granular, and the article must then be reheated and slowly cooled to restore the fine grain required in good tools. When annealing it this steel should be slowly and uniformly heated to a barely visible red-heat, and laid aside to cool under lime, ashes, or sand. With careful handling it can be made to weld perfectly.

190. The Changes due to Hardening and Tempering are not fully understood. The temperature at which the change occurs with common tool-steel seems to be about that at which the metal begins to exhibit color—a low, barely visible red-heat, as seen in the dark. Any treatment which, quickly reducing the temperature, causes the passing of this line on the scale of temperature, hardens steel. It would seem, therefore, that at a low heat but slight cooling is necessary to harden steel. Even metals in fusion, when their melting points are below this critical temperature, may be used in tempering, and will produce this effect to an extent which is determined by the difference of the temperatures of the metals at the moment, and by their relative conductivities and capacities for heat.

Water is the most efficient of all fluids if properly used, as it has a high specific heat and great capacity for taking up heat while changing in temperature or while vaporizing. It acts most efficiently when thrown upon the steel in fine spray from under great pressure, and a stream of flowing water is better than still water where great hardness is desired, as a vaporous cushion protects the surface of the metal in quiet water, and checks the absorption of heat; a stream of boiling water often hardens more than does still, but cold, water. The highest efficiency is attained when the amount of water used is just sufficient to evaporate completely.

The change which occurs in hardening steel is, then, a physical alteration of structure which occurs at some point between 800° and 1,000° Fahr. (427° to 538° Cent.), and it is

the more complete as the reduction of temperature of the metal is the more rapid. Jarolineck places the critical temperature at 932° Fahr. (500° Cent.), as determined by him experimentally. The "self-hardening," and possibly some other steels, have cutting speeds which increase with the temperature from which they are cooled, up to about 1,500° or 1,600° F., then fall off until a minimum is reached at about 1,700°, after which increase again begins, and the cutting speed rapidly increases up to temperatures approximating 2,000°, at which point the speed may become two or three times the earlier maximum. The "Taylor-White" process involves this treatment.*

191. Compression of Steel while Cooling has been practiced by Clémendot. Thus, metals, if compressed by a sufficiently high pressure to somewhat increase their density, and held thus compressed while cooling from a full "cherry-red" heat, are permanently strengthened. The effect upon steel is precisely that obtained by tempering. This process is therefore called by him "*tempering by compression.*"

Hammering produces this effect, but hydraulic pressure is better.

The advantages claimed for the Clémendot method are: (1.) It may be graduated and adapted to any special case. (2.) The operation may be specified in advance by prescribing the intensity of pressure to be applied. (3.) It is a more exact, manageable, and certain process than the usual methods of hardening and tempering.

The effect of this compression has been found by M. Lan † to be an alteration in the proportion of combined carbon, as in the tempering by the ordinary method, thus:

Carbon total.	A.	B.	C.	D.	Mean.	Free C.
Uncompressed steel..0.70	0.49	0.50	0.47	0.50	0.490	0.210
Compressed steel...0.70	0.60	0.59	0.55	0.60	0.585	0.115

192. Cofrosion of Iron and Steel, and the chemical changes which produce or accompany that method of dete-

* *Jour. Frank. Inst.*, Sept., 1901.

† *Comptes Rendus*, Vol. xciv., 1882, p. 952.

rioration, cannot go on in the air except when both moisture and carbonic acid are present, or unless the temperature is considerably higher than that of the atmosphere. When exposed to the action of free oxygen, however, under either of these conditions, the metal is corroded—rusts—rapidly or slowly, according to its purity. Wrought iron rusts quickly in damp situations, and especially when near decaying wood or other source of carbonic acid; while steels are corroded with less rapidity, and cast iron is comparatively little acted upon. The presence of acids in the atmosphere accelerates corrosion, and the smoke of sulphur-charged coal, or smoke charged with pyroligneous acid, frequently causes the oxidation of out-of-door iron structures.

The composition of the rust forming upon surfaces of iron is determined by the method of oxidation, but is principally peroxide of iron. Calvert gives the following:

	Rust from Conway Bridge.	Llangollen.
Fe ₂ O ₃	93.094	92.900
FeO	5.810	6.177
Carbonate of iron	0.900	0.617
Silica	0.196	0.121
Ammonia	traces	traces
Carbonate of lime	0.295

A series of experiments made to determine the effect of different oxidizing media, after four months' exposure of clean iron and steel blades, gave the following result: *

Dry oxygen—no oxidation.

Damp oxygen—in three experiments one blade only was slightly oxidized.

Dry carbonic acid—no oxidation.

Damp carbonic acid—slight appearance of a white precipitate upon the iron (found to be carbonate of iron).

Dry carbonic acid and oxygen—no oxidation.

Damp carbonic acid and oxygen—oxidation very rapid.

Dry and damp oxygen and ammonia—no oxidation.

Indicating that oxidation is principally due to the presence of carbonic acid with oxygen.

* *Chemical News*, 1870-1871.

When distilled water was deprived of its gases by boiling, and a bright blade introduced, it became in the course of a few days here and there covered with rust. The spots where the oxidation had taken place were found to mark impurities in the iron, which had induced a galvanic action, precisely as a mere trace of zinc placed on one end of the blade would establish a voltaic current.

Kent has shown* that the rusting of iron railroad bridges is sometimes greatly accelerated by the action of the sulphurous gases and the acids contained in the smoke issuing from the locomotive, and that sulphurous acid rapidly changes to sulphuric acid in the presence of iron and moisture, thus greatly accelerating corrosion. Iron and steel absorb acids, both gaseous and liquid, and are therefore probably permanently injured whenever exposed to them.

Calvert experimented upon iron immersed in water containing carbonic acid, in sea water, and in very dilute solutions of hydrochloric, sulphuric, and acetic acids. A piece of cast iron placed in a dilute acetic acid solution for two years, was reduced in weight from 15.324 grammes to $3\frac{1}{2}$ grammes, and in specific gravity from 7.858 to 2.631, while the bulk and outward shape remained the same. The iron had gradually been dissolved or extracted from the mass, and in its place remained a carbon compound of less specific weight, and small cohesive force. The original cast iron contained 95 per cent. of iron and 3 per cent. of carbon, the new compound only 80 per cent. of iron and 11 per cent. of carbon. Iron immersed in water containing carbonic acid was also found to oxidize rapidly. Iron exposed to the wash of the warm aerated water of the jet condensers of steam engines is often very rapidly oxidized, and the mass remaining after a few years often has the appearance, texture, and softness of plumbago, so completely is the iron removed and the carbon isolated.

Mallett, experimenting for the British Association,† found the rate of corrosion of cast iron greatly accelerated by

* *Iron Age*, 1875.

† *Proc. Inst. C. E.*, 1843.

irregular and rapid cooling, and retarded by a slow and uniform reduction of temperature while in the mould.

The rate of corrosion is usually nearly constant for long periods of time, but it is retarded by removal of the coating formed by the rust, as, if left, it creates a voltaic couple, which accelerates corrosion.

Hard iron, free from graphite, but rich in combined carbon, rusts with least rapidity, and with about equal rapidity in the sea as in the air, in an insular climate. Two metals of different character as to composition or texture being in contact, the one is protected at the expense of the other. Foul sea-water, as "bilge-water," corrodes iron very rapidly.

The rate of corrosion of iron is too variable to permit any statement of general application. In several cases the plates of iron ships have been found to be reduced in thickness in the bilges and along the keel strake, at the rate of 0.0025 inch (0.06 millimetres) per year, as ordinarily protected by paint, while it is stated that iron roofs, exposed to the smoke of locomotives, have sometimes lasted but four years.

The iron hulls of heavy iron-clads have sometimes been locally corroded through in a single cruise, where peculiarities of composition or of structure, or the proximity of copper or of masses of iron of different grade or quality had caused local action. (See Appendix.)

193. Durability of Iron and Steel.—Thwaite* gives the following as the measure of the probable years' life of iron and steel undergoing corrosion, assuming the metal to be uniform in thickness. Thin parts corrode most rapidly.

$$T = \frac{W}{CL},$$

in which W is the weight of the metal in pounds, of one foot in length of the surface exposed; L is the length in feet, of its perimeter, and C a constant, of which the following are values :

* Molesworth, p. 32, 21st ed., 1882.

VALUES OF *C*.

MATERIAL IN	SEA WATER.		RIVER WATER.		IMPURE AIR.	AVERAGE SEA WATER
	Foul.	Clear.	Foul.	Clear, or in air.		
Cast iron.....	.0656	.0635	.0381	.0113	.0476
Wrought iron.....	.1956	.1255	.1440	.0123	.1254
Steel.....	.1944	.0970	.1133	.0125	.1252
Cast iron, skin removed...	.2301	.0880	.0728	.0109	.0854
“ galvanized.....	.0895	.0359	.0371	.0048	.0199
“ in contact with brass, copper, or gun bronze.....						0.19 to 0.35
Wrought iron in contact with brass, copper, or gun bronze.....						0.30 to 0.45

When wear is added to the effect of oxidation, the “life” of a piece of iron or steel may be greatly shortened. If kept well painted, multiply the result by two.

The mean duration of rails of Bessemer steel is, according to experiments in Germany, about sixteen years. Ten years of trial at Oberhausen, on an experimental section of the line between Cologne and Minden, has shown that the renewals during the period of trial were 76.7 per cent. of the rails of iron of fine grain, 63.3 of those of cementation steel, 33.3 per cent. of those of puddled steel, and 3.4 per cent. Bessemer steel.

194. The Preservation of Iron and Steel is accomplished usually by painting, sometimes by plating it.

As the more porous varieties will absorb gases freely and some liquids to a moderate extent, Sterling has proposed to saturate the metal with mineral oil; heating the iron and forcing the liquid into the pores by external fluid pressure, after first freeing the pores from air by an air-pump, or other convenient means of securing a vacuum in the inclosing chamber.

Temperatures of 300° to 350° Fahr. (150° to 177° Cent.), and pressures of 10 to 20 atmospheres are said to be sufficient for all purposes.

Voltaic action may be relied upon to protect iron against corrosion in some situations. Zinc is introduced into steam boilers for the double purpose of preventing corrosion, and of

checking the deposition of scale. It is sometimes useful in the open air where rusting is so seriously objectionable as to justify the use of so expensive a preventative. The zinc itself is often quickly destroyed,

Zinc has been used as a plating, or sheathing, on iron ships, as by the plan proposed by Daft,* and in some cases with good results.

Mallett has proposed the use of lime-water to check the internal corrosion of the bottoms of iron ships where exposed to the action of bilge-water, and uses a solution of the oxychloride of copper, or other poisonous metallic salts, in the paint applied externally, to check fouling and consequent oxidation; the amalgam of zinc and mercury is also sometimes used to protect iron plates.

195. The Paints and Preservation Compositions in use are very numerous: Coal-tar, asphaltum and the mineral oils are all used, the latter having the advantage, in the crude state, of being free from oxygen and having no tendency to absorb it. [See Part I. for Composition of Paints.]

The animal and vegetable fats and oils are used temporarily in many cases, and, if free from acid, are useful.

Surfaces of iron are painted with red-lead and oil, with oxide of iron mixed with oil, or with oxide of zinc similarly prepared, and Colton proposes mixtures to be made thus for ships' bottoms:

First, cover the vessel's bottom with two or even three coats of red lead, and give time for each to dry hard. Then melt in an iron pot a mixture of two parts beeswax, two parts tallow, and one part pine resin; mix thoroughly, and apply hot one or two coats. This mixture may be tinted with vermilion or chrome green. It is not necessary to use any poisonous substance, as it is only by its softness and gradual wear that it is kept clean. Second mix red lead and granular metallic zinc, ground fine, or such a mineral as we have mentioned—crystalline and granular in its character. Put on two or three coats, and allow each to set; they will

* *Fouling and Corrosion of Iron Ships*, London, 1867.

never dry hard. The zinc will slowly wear off, keeping the whole surface clean, while there will be left enough lead to preserve the iron from rust. The oil used for these pigments is linseed—boiled as little as possible, and thinned with spirits of turpentine.

Sterling prepares a varnish for this purpose by dissolving gum copal in paraffine oil, placing the iron in it, and heating it under increased pressure. Iron vessels, tinned inside, which can be hermetically sealed, are used, heated by superheated steam. Scott uses the following mixture :

Coal tar.....	6 gallons.
Black varnish.....	3 “
Wood tar oil.....	2 “
Japanese glue.....	1 “
Red lead.....	28 lbs.
Portland cement.....	14 “
Arsenic.....	14 “

The Author has used fish-oil as a preservative of steam boilers out of use for long periods of time, with success, and has found some vegetable paints of unknown composition far more durable, when exposed to the weather, than red lead and oil.

Red lead mixed with barytes and raw linseed oil or zinc oxide similarly prepared are probably the best compositions for painting iron. The oil usually constitutes about 10 per cent. of the mixture and the barytes may be introduced to the extent of double the weight of the lead.

Where practicable the Barff method of protection may be adopted. It consists in heating the iron or steel to be treated to a temperature of 500° Fahr. (260° Cent.) in an atmosphere of steam, and thus securing an even and impermeable coating of the black (ferric) oxide.

Where more complete protection is demanded, the iron is heated to 1,200° Fahr. (649° Cent.), and is said to be thus made impregnable against the attack of even the acrid vapors of the chemical laboratory, and to remain unaffected by

any temperature below the red heat. This is, in fact, a process of producing "Russia iron," the glazed surface of which has the same composition as Barff's protecting coating.

Iron gun-carriages and similar plate-iron structures are preserved in store by first cleaning them carefully, and then covering them with two coats of iron paint, after washing in hot linseed oil. Tools and bright parts of small work are preserved by frequently rubbing them with good sperm oil, and "bright work," not likely to be suddenly required for use, or if to be packed for transportation, is covered with a mixture of tallow and white lead ground in oil. A mixture of one part by weight of tallow to six of white lead is useful for preserving the bright parts of marine steam engines; the Author has used one of tallow to eight or ten of lead, as better where greater hardness and permanence are desirable, as during transportation of heavy pieces of finished work.

Metals should always be stored in dry, well-aired buildings, and usually on the ground floor. Iron and steel bars are stacked on end, or stored in racks. Sheet-iron, tin, sheet-copper and zinc, are well oiled, and stored on edge in racks. Tools in store are often sprinkled with quicklime or charcoal.

196. Special Compositions are used, and special methods are applied in some cases. Gun-barrels and some other small pieces of finished work are often "browned," The mixture used is thus made :

1.5	parts	alcohol.
1.5	"	tincture of steel ; chloride of iron.
1.5	"	bichloride mercury.
1.5	"	sweet spirits of nitre.
1.0	"	blue vitriol.
0.75	"	nitric acid.

These are mixed and dissolved in a quart of pure water.

The piece to be browned is very carefully cleaned, and is given a clear, fresh metallic surface, by the use of fine emery or the file, and all grease is removed by rubbing with lime-dust. The surface is then rusted by 24 hours' exposure to the air, and is next well scrubbed with a steel scratch-brush.

The browning mixture is then applied at intervals of several hours, the rust produced during each period being well rubbed in with the brush before applying the next coat. When well browned, the surface is washed in hot water, and, when dry and cold, it is well oiled. A varnish of shellac and dragon's blood, dissolved in alcohol, is used when desired.

Lacquer for iron ordnance is made of

12	parts	black lead.
12	"	red lead.
5	"	litharge.
5	"	lampblack.
66	"	linseed oil.

The mixture is boiled 20 minutes, with constant stirring.

Another formula is the following :

3.75	parts	ground umber.
3.75	"	shellac.
3.75	"	ivory black.
3.75	"	litharge.
7.25	"	spirits turpentine.
78	"	linseed oil.

In this case the oil is first boiled half an hour, and the mixture is then boiled 24 hours.

A less complex and cheaper mixture consists of :

16	parts	coal tar.
1	part	turpentine.

Lacquering is best and most easily done out of doors in the warm season ; the lacquer is laid on with sheep-skin gloves, made up with the wool outside.

For small pieces, and for waterproof materials, a lacquer is made of beeswax and turpentine, with a little linseed oil ; for polished work of

80.5	parts	linseed oil.
11.25	"	white lead in oil.
5.5	"	litharge.
2.75	"	rosin.

Heat it to simmering over a slow fire, adding the lead and rosin after straining, and stirring while cooling.

A lacquer for finished parts of brass or bronze instruments is made by dissolving shellac, or sticklac, in alcohol, and is applied to the piece while the latter is warm. Sticklac is best. Such parts are sometimes blackened with dilute nitric acid.

Gas mains and other pipes laid underground are protected against corrosion by a coating of coal tar. This is sometimes mixed with Burgundy pitch, oil, and resin. The mixture is heated to about 400° Fahr. (204° Cent.); the pipes are lowered into the bath and allowed to take the temperature of the liquid, when they are taken out and set on end to drain and cool. When cold they are ready for use.

Iron can be cleaned before painting by dipping first into a solution of vitriol, or other acid, and then into an alkaline solution—lime, potash, or soda. (See Appendix.)

197. Steam Boilers are preserved against corrosion by various special methods. They are sometimes dried thoroughly by means of stoves, if necessary, and then closed up with a quantity of caustic lime in their water bottoms or lower water spaces. Occasional inspection prevents injury occurring undetected in any case.

When new boilers are stored they are usually painted inside and out. Air should be excluded from them by closing all man-holes, etc. Working boilers are best preserved by a thin coating of scale on their heating surfaces. Mineral oils being used for lubrication of their engines, decay is far less likely to take place rapidly. Steel corrodes less rapidly than iron, and the common brands of iron corrode less than the finer. Zinc placed within boilers, and in amount one thirty-fifth the area of the heating surface, was found, by the British Admiralty, to protect them perfectly. A pound (0.45 kilogrammes) of carbonate of soda to every ton (or *tonne*) of coal burned, is ordered to be pumped into boilers at sea, to give the water an alkaline reaction. Boilers of sea-going vessels average a life of nine or ten years.

Cast-iron pipes should be protected by oiling immediately

after cleaning in the foundry, and before they are laid, by heating and coating with some bituminous material, as above. Their cost is thus increased from one to two dollars per ton, but their life may be increased many years—sometimes twenty years may elapse without serious deterioration. Corrosion is here not only a cause of loss of metal, but often of injury to the contents of the pipe, and of retardation of flow by filling it up.

The factor of safety for iron construction is made large enough to cover a considerable loss of strength by oxidation.

Galvanized iron is often painted as well as ungalvanized metal. In galvanizing iron, the article is "pickled" six or eight hours in acidulated water (about one per cent. sulphuric acid); it is then scoured and well rinsed in clean water, and finally immersed in lime water until wanted. A bath of chloride of zinc and sal ammoniac (8:1) is prepared; the iron is dipped and then carefully dried before sending it to the galvanizing trough. The latter contains molten zinc, the surface of which is protected by sal ammoniac or charcoal. The iron is kept in this bath until fully up to its temperature, when it is removed ready for use.

Concrete, if well mixed and well laid down, preserves iron imbedded in it indefinitely. Iron in the cemented bases of Egyptian obelisks has endured, without apparent injury, thousands of years. Iron uncovered at Pompeii showed no signs of oxidation where it had been covered with volcanic dust and ashes. Drift-bolts of iron, taken from concrete under a lighthouse keeper's dwelling, have been found perfectly preserved. (Trans. Am. Soc. C. E., Vol. XXVIII.)

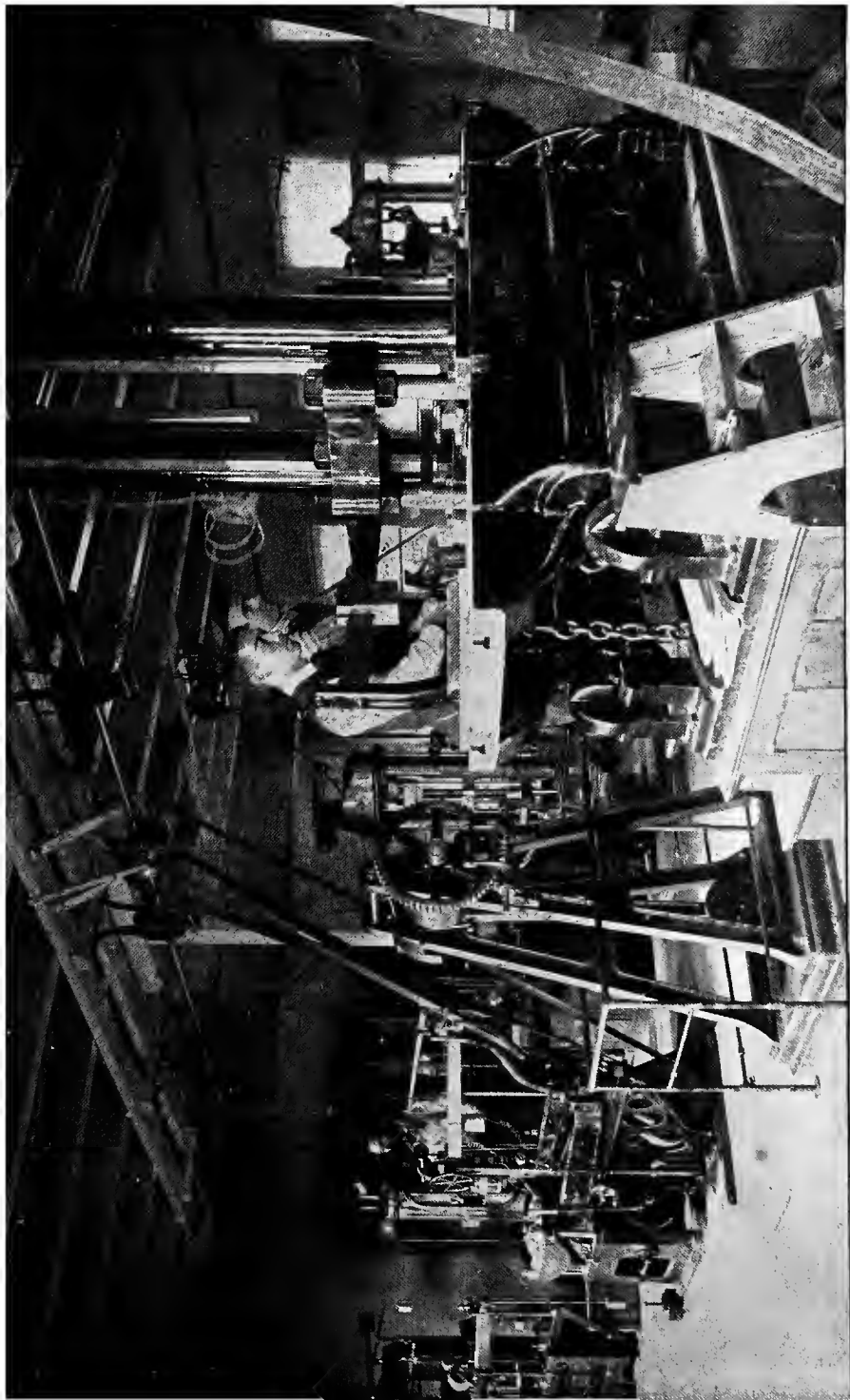

LABORATORY OF STRENGTH OF MATERIALS: SIBLEY COLLEGE, CORNELL UNIVERSITY. ORGANIZED BY R. H. THURSTON, 1885.

[Face page 339.]

CHAPTER IX.

STRENGTH, ELASTICITY, AND RESILIENCE OF IRON AND STEEL.

198. The Resistance of Iron and Steel to rupture may be brought into play by either of five methods of stress, which have been thus divided by the Author :

Longitudinal.....	{ Tensile : resisting pulling force. Compression : resisting crushing force
Transverse.....	{ Shearing : resisting cutting across. Bending : resisting cross breaking. Torsional : resisting twisting stress.

Two or more of these methods of distortion may affect a piece at once, as is illustrated in the action of a crank or of any lever acting on the end of a shaft, tending, at the same time, to bend, to twist, and to shear it. Pieces must be so proportioned, therefore, as to be safe against any combination of stresses to which they are liable to be subjected under usual conditions of work.

When a load is applied to any part of a structure or of a machine, it causes a change of form which may be very slight, but which always takes place, however small the load. This change of form is resisted by the internal molecular forces of the piece, *i. e.*, by its cohesion. The change of form thus produced is called *strain*, and the acting force is a *stress*.

The *Ultimate Strength* of a piece is the maximum resistance under load—the greatest stress that can exist before rupture. The *Proof Strength* is the load applied to determine the value of the material tested when it is not intended that observable deformation shall take place. It is usually equal, or nearly so, to the maximum elastic resistance of the piece. It is sometimes said that this load, long continued, will produce

fracture; but, as will be seen hereafter, this is not necessarily, even if ever, true.

The *Working Load* is that which the piece is proportioned to bear. It is the load carried in ordinary working, and is usually less than the proof load, and is always some fraction, determined by circumstances, of the ultimate strength.

A *Dead Load* is applied without shock, and, once applied, remains unchanged, as, *e. g.*, the weight of a bridge; it produces a uniform stress. A *Live Load* is applied suddenly, and may produce a variable stress, as, *e. g.*, by the passage of a railroad train over a bridge.

The *Extension* or *Distortion* of the strained piece is related to the load in a manner best indicated by the strain diagrams to be given. Its value as a factor of the measure of shock-resisting power, or of resilience, is exhibited in a later article. It also has importance as indicating the ductile qualities of the metal.

The *Reduction of Area of Section* under a breaking load is similarly indicative of the ductility of the material, and is to be noted in conjunction with the distortion.

E. g. A considerable reduction of section with a smaller proportional extension would indicate a lack of homogeneity, and that the piece had broken at a weak part of the bar. The greater the extension in proportion to the reduction of area in tension, the more uniform the character of the metal.

199. Factors of Safety.—The ultimate strength, or maximum capacity for resisting stress, has a ratio to the maximum stress due to the working load, which, although less in metal than in wooden or stone structures, is, nevertheless, made of considerable magnitude in many cases. It is much greater under moving than under steady "dead" loads, and varies with the character of the material used. For machinery it is usually 6 or 8; for structures erected by the civil engineer, from 5 to 6. The following may be taken as minimum values of this "factor of safety:"

MATERIAL.	LOAD.		SHOCK.	
	Dead.	Live.		
Wrought iron ; soft steel....	3	6	8 +	Ratio of Ultimate Strength to Working Load.
Tool and machinery steel....	3	6	9 +	
Cast iron.....	4	7	10 to 15	

The Proof Strength usually exceeds the working load from 50 per cent., with tough metals, to 200 or 300 per cent. where cast iron is used. It should usually be below the elastic limit of the material, and the value of metals should be generally considered as limited by their elastic resistance.

As this resistance, with brittle materials, is often nearly equal to their ultimate strength, a set of factors of safety, based on the elastic limit, would differ much from those above given for ductile metals, but would be about the same for all brittle materials, thus :

MATERIAL.	LOAD.		SHOCK.	
	Dead.	Live.		
Wrought Iron ; Soft Steel.....	1	2	3	Ratio of Elastic Resistance to Working Load.
Machinery Steel.....	1½	3	5	
Tool Steel.....	2	4	6	
Cast Iron ; Foundry.....	3	6	8 to 12	

The figure given for shock is to be taken as approximate, but used only when it is not practicable to calculate the energy of impact and the resilience of the piece meeting it, and thus to make an exact calculation of proportions.

The factors of safety adopted for iron and steel are lower than those usually admissible for construction in other materials in consequence of the fact that the elastic limit and the elastic resilience, or shock-resisting power of the former seem to increase, up to a limit, with strain ; while the latter

gradually yield under comparatively low stresses, as will be seen hereafter. In common practice, the factor of safety covers not only risks of injury by accidental excessive stresses, but deterioration with time, uncertainty as to the character of uninspected material, and sometimes equally great uncertainty as to the absolute correctness of the formulas and the constants used in the calculations. As inspection becomes more efficient and trustworthy; as our knowledge of the effect of prolonged and of intermitted stress becomes more certain and complete; as our formulas are improved and rationalized, and as their empirically determined constants are more exactly obtained, the factor of safety is gradually reduced, and will finally become a minimum when the engineer acquires the ability to assume with confidence the conditions to be estimated upon, and to say with precision how his materials will continuously carry their loads.

In general, parts of structures are so proportioned as to carry their loads without risk of exceeding their elastic limits; and in such cases the factor of safety should probably always be referred to the elastic limit. When a margin is demanded to meet risks of occasional extraordinary stresses that are liable to produce rupture, as in machinery, the factor is to be based on the ultimate strength. This difference may dictate the adoption of different forms as well as proportions.

The elastic limit is made the basis of estimates by nearly all French engineers, while the ultimate strength is taken by German engineers, using a factor of safety of larger magnitude. British and American engineers usually base all calculations on the ultimate strength, although the former system is extending in general practice, and the limit of working load is made to fall within the limit of elasticity.

Where the stresses are intermitted, the position of the elastic limit has especial importance, since it is found by experience that the load may be removed and applied an indefinite number of times within this limit without producing fracture, while, when it exceeds this amount, a comparatively few applications may cause rupture. For general pur-

poses, the position of the limit of elasticity is of far more importance than the ultimate strength.

200. Limiting Values of Stress, due to the working load, are often fixed which constitute the provisions for safety.

Tension members, in heavy structures, when of wrought iron, are usually calculated for a load of 10,000 pounds per square inch (703 kilogrammes per square centimetre). Struts and compression members are loaded to 8,000 (562 kilogrammes), and members subjected to orthogonal stresses are allowed from 5,000 to 7,000 pounds (350 to 500 kilogrammes). Steel is allowed, in such structures, fifty per cent. higher loads; cast iron is often loaded to one-third the given figures.

It is sometimes customary, in bridge-work, to allow an increase of assumed load, when moving, of 15 to 25 per cent. on small spans, of 10 per cent. on spans of 50 to 100 feet, but no more on large spans.

In other cases, the estimates are based on an assumed load of 5,000 or 6,000 pounds per running foot (7,450 to 9,000 kilogrammes per metre), on short spans; 3,000 to 4,000 pounds per foot (4,500 to 6,000 kilogrammes per metre), on spans of 50 to 150 feet (15 to 45 metres), and from one ton to 2,500 pounds (3,400 to 3,700 kilogrammes per metre) on very long spans—300 to 500 feet (90 to 150 metres). It may be questioned whether a moving load can produce the effect of impact to any serious extent.

In some cases it is advisable to design some minor part, or element, of a train with a lower factor of safety, to insure that when a breakdown does occur it shall be certain to take place where it will do least harm.

For example, a "breaking piece" connects the engine-shaft with the rolls in rolling mills, since cold iron is sure to be entered into the rolls occasionally, and will inevitably break the weakest element of the train transmitting power.

201. The Measure of Resistance to *strain* is determined, in form, by the character of the *stress*. By stress is here understood the force exerted, and by strain the change of form produced by it.

Tenacity is resistance to a pulling stress, and is measured

by the resistance of a section, one unit in area, as in pounds or tons on the square inch, or in kilogrammes per square centimetre or square millimetre. Then, if T represents the tenacity and K is the section resisting rupture, the total load that can be sustained is, as a maximum,

$$P = TK \dots \dots \dots (1)$$

Compression is similarly measured, and if C be the maximum resistance to compression per unit of area, and K the section, the maximum load will be

$$P = CK \dots \dots \dots (2)$$

Shearing is resisted by forces expressed in the same way, and the maximum shearing stress borne by any section is

$$P = SK \dots \dots \dots (3)$$

Bending Stresses are measured by moments expressed by the product of the bending effort into its lever-arm about the section strained, and if P is the resultant load, l the lever-arm and M the moment of resistance of the section considered,

$$Pl = M \dots \dots \dots (4)$$

Torsional Stresses are also measured by the moment of the stress exerted, and the quantity of attacking and resisting moments is expressed as in the last case.

Elasticity is measured by the longitudinal force, which, acting on a unit of area of the resisting section, if elasticity were to remain unimpaired, would extend the piece to double its original length. Within the limit at which elasticity is unimpaired, the variation of length is proportional to the force acting, and if E is the "*Modulus of Elasticity*," l the length, and e the extension, P being the total load, and K the section :

$$E = \frac{Pl}{eK} \dots \dots \dots (5)$$

$$e = \frac{Pl}{EK} \dots \dots \dots (6)$$

The *Coefficients* entering into these several expressions for resistance of materials are often called *Moduli*, and the forms of the expressions in which they appear are deduced by the Theory of the Resistance of Materials, and the processes are given in detail in works on that subject.*

These moduli, or coefficients, as will be seen, have values which are rarely the same in any two cases; but vary not only with the kind of material, but with every variation, in the same substance, of structure, size, form, age, chemical composition or physical character, with every change of temperature, and even with the rate of distortion and method of action of the distorting force. Values for each familiar material, for a wide range of conditions, will be given in the following pages.

202. Method of Resistance to Stress.—When a piece of metal is subjected to stress exceeding its power of resistance for the moment, and gradually increasing up to the limit at which rupture takes place, it yields and becomes distorted at a rate which has a definitely variable relation to the magnitude of the distorting force; this relation, although very similar for all metals of any one kind, differs greatly for different metals, and is subject to observable alteration by every measurable difference in chemical composition or in physical structure.

Thus, in Fig. 59, let this operation be represented by the several curves, *a*, *b*, *c*, *d*, etc., the elevation of any point on the curve above the axis of abscissas, *OX*, being made proportional to the resistance to distortion of the piece, and to the equivalent distorting stress, at the instant when its distance from the left side of the diagram, or the axis of ordinates, *OY*, measures the coincident distortion. As drawn, the strain-diagram, *a a'*, is such as would be made by a soft metal like tin or lead; *b b'* represents a harder, and *c c'* a still harder and stronger metal, as zinc and rolled copper. If the smallest divisions measure the per cent. of extension horizontally, and 10,000 pounds per square inch (703 kilogrammes per square

* Consult *Resistance of Materials*; D. V. Wood: N. Y., J. Wiley & Sons.

centimetre) vertically, dd' , would fairly represent a hard iron, or a puddled or a "mild" steel; while ff' and gg' would be strain diagrams of hard, and of very hard tool steels, respectively.

The points marked $e, e', e'',$ etc., are the so-called "elastic

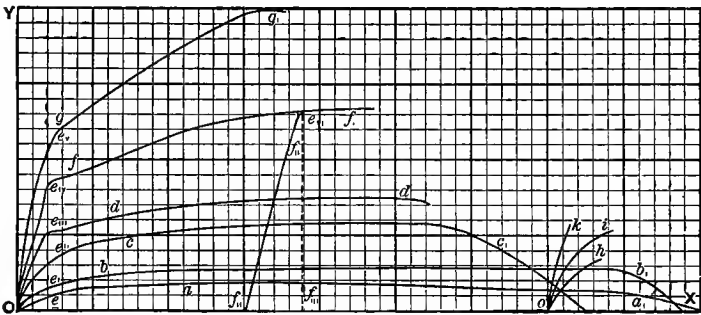

FIG. 59.—STRAIN-DIAGRAMS.

limits," at which the rate of distortion more or less suddenly changes, and the elevation becomes more nearly equal to the permanent change of form, and at these points the resistance to further change increases much more slowly than before. This change of rate of increase in resistance continues until a maximum is reached, and, passing that point, the piece either breaks, as at f' and g' , or yields more and more easily until distortion ceases, or until fracture takes place, and it becomes zero at the base line, as at X .

Such curves have been called by the Author "Strain-diagrams," and will be considered at greater length hereafter.

203. Equations of Curves of Resistance or Strain-diagrams.—These curves are, at the start, often nearly parabolic, and the strain-diagrams of cast iron, h, i, k , having their origin at o , are usually capable of being quite accurately expressed by an equation of the parabolic form, as

$$P = A \frac{e}{l} - B \frac{e^2}{l^2} \dots \dots \dots (7)$$

in which Hodgkinson found the constants for gray English cast iron in tension to be

$$A = 14,000,000; B = 3,000,000,000,$$

and where $\frac{e}{l}$ is the ratio of elongation to the length of the piece, and P , the load, is measured for tension, in pounds on the square inch of resisting section.

For wrought iron of fair quality, and for the initial part of the diagram, the Author has, in some experiments, obtained : *

$$A = 20,000,000; B = 100,000,000.$$

For soft steels for rails, he obtained nearly

$$A = 25,000,000; B = 125,000,000;$$

and for several tool-steels an average of

$$A = 30,000,000; B = 1,000,000,000.$$

The coefficient A , above, is the modulus of elasticity. Reducing the above quantities to metric measure—kilogrammes on the square centimetre—we have :

	A.	B.
For gray cast iron.....	984,200	210,900,000
For fair wrought iron.....	1,407,000	7,030,000
For soft steel.....	1,757,500	8,787,500
For tool steel.....	2,109,000	70,300,000

204. The Series of Elastic Limits.—If, at any moment, the stress producing distortion is relaxed, the piece recoils and continues this reversed distortion until, all load being taken off, the recoil ceases and the piece takes its “permanent set.” This change is shown in the figure at $f'' f''$, the gradual reduction of load and coincident partial restoration of shape being represented by a succession of points forming the line $f'' f''$, each of which points has a position which is determined by the elastic resistance of the piece as now altered by

* Mechanical Treatment of Metals; *Metallurgical Review*, 1877.

the strain to which it has been subjected. The distance $O f''$ measures the permanent set, and the distance $f'' f'''$ measures the recoil.

The piece now has qualities which are quite different from those which distinguished it originally, and it may be regarded as a new specimen and as quite a different metal. Its strain-diagram now has its origin at f'' , and the piece being once more strained, its behavior will be represented by the curve $f'' f''' e^v, f'$, a curve which often bears little resemblance to the original diagram O, f, f' . The new diagram shows an elastic limit at e^v , and very much higher than the original limit e^v . Had this experiment been performed at at any other point along the line $f f'$, the same result would have followed. It thus becomes evident that the strain-diagram is a curve of elastic limits, each point being at once representative of the resistance of the piece in a certain condition of distortion, and of its elastic limit as then strained.

It becomes necessary to distinguish these elastic limits in describing the behavior of strained metals, and, as will be seen subsequently, the elastic limits here described are, under some conditions, altered by strain, and we thus have another form of elastic limit to be defined by a special term.

In this work the original elastic limit of the piece in its ordinary state, as at e, e', e'' , etc., will be called either the *Original*, or the *Primitive, Elastic Limit*, and the elastic limit corresponding to any point in the strain-diagram produced by gradual, unintermitted strain, will be called the *Normal Elastic Limit* for the given strain. It is seen that the diagram representing this kind of strain is a *Curve of Normal Elastic Limits*.

The elastic limit is often said to be that point at which a permanent set takes place. As will be seen, on studying actual strain-diagrams to be hereafter given, and which exhibit accurately the behavior of the metal under stress, there is no such point. It was supposed probable by Hodgkinson that every stress, however slight, may produce a permanent change of form, and this is found to be the fact by later investigations. The Author has detected sets far within

the elastic limit shown on the strain-diagram for every familiar metal and alloy. This fact is best shown by the automatically produced strain-diagram obtained from the "autographic recording machine," on which it is easy to measure extensions of the most severely strained fibre, even though as small as one ten-millionth of an inch—*i. e.*, corresponding to less than one-tenth of a degree of torsion of the standard test-piece.

When it is not practicable to measure more accurately than with ordinary instruments, the elastic limit for iron and steel is often assumed to exist at an extension of 0.001 of the length of the part measured.

The "resilience," the work of rupture, or of distortion, is measured by the area of the diagram to either limit.

205. Strain-Diagrams.—The tables on pages 351–353 illustrate the usual methods of recording results of test as adopted by various investigators. One method of test to be described results in the production of an automatically produced "strain-diagram," of which the ordinates represent stresses and the abscissas the distortions caused by these stresses. This system may be applied to other methods of test, and has been found by the Author, in his own work, to give a much readier means of exhibiting the character of the material tested than the tabular statements, such as are given in this article. Such diagrams have already been described. The advantage possessed by these curves of resistances, or of the normal succession of elastic limits, over any other method of record, consists in the fact that they present to the mind at a glance every characteristic of the metal tested; the position absolute and relative of the elastic limit; the method of variations of resistance with stress and strain; the ultimate strength of the piece, and the resilience, both elastic and total.

It will be seen later that the autographic strain-diagram produced by the torsion machine exhibits the peculiarities of the metal at the elastic limit and the immediate vicinity with extraordinary accuracy in consequence of the enormous magnification of the initial part of the diagram; but it will

be found that the plotted diagram, representing the tabulated figures of the tension or compression on the transverse tests, may often enable the elastic limit to be located where an inspection of the figures themselves gives but a slight clue. The strain-diagram also gives an exact and easily measured value of resilience, while the tables give no measure of that important quality.

The following illustrates the method of preparation of such curves from the records. Tables XLI., XLII., following, are records of test of pieces of a bar of "ingot iron" tested under the direction of the Author for the Committee on Chemical Research of the United States Board appointed to test metals. The tables also present the chemical composition of the metal.

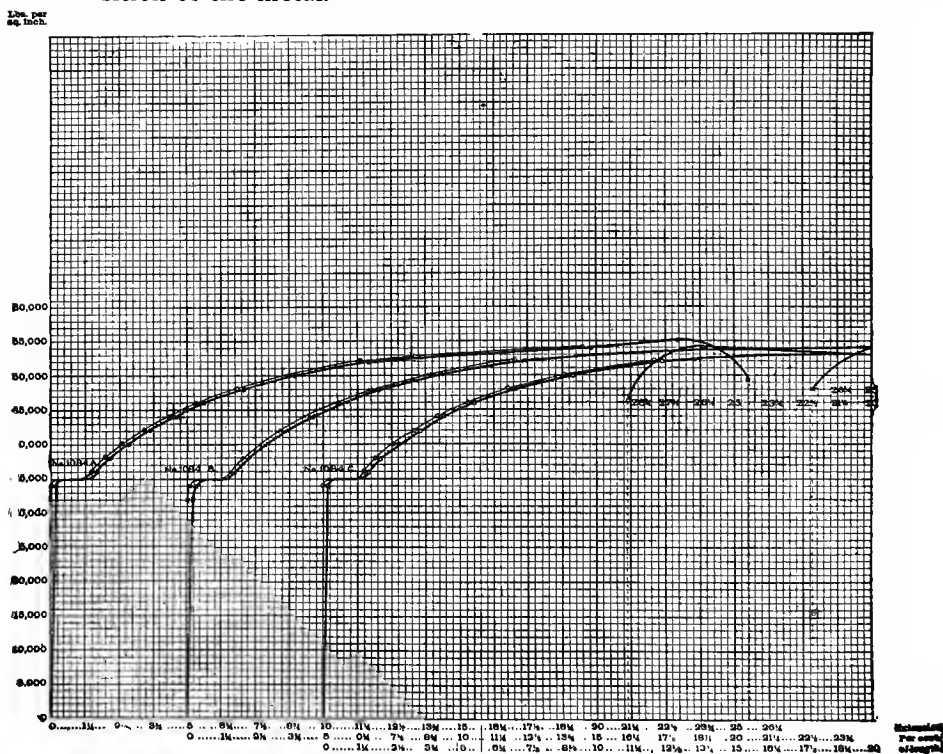

FIG. 60.—STRAIN-DIAGRAMS OF INGOT-IRON.

TABLE XLI.

RECORD OF TESTS BY TENSILE STRESS.

STEEL FURNISHED COMMITTEE ON CHEMICAL RESEARCH.

Original mark, X. B. Iron. No. 1084 A. Dimensions: Length, 6"; diameter, 0.798".

LOADS.		EXTENSIONS AND SETS.		LOADS.		EXTENSIONS AND SETS.	
Actual.	Per sq. inch.	Actual.	Per cent. of length.	Actual.	Per sq. inch.	Actual.	Per cent. of length.
<i>Pounds.</i>	<i>Pounds.</i>			<i>Pounds.</i>	<i>Pounds.</i>		
150				150		Set .4094	Set 6.823
2,000	4,000	.0010	.016	25,000	50,000	.5421	9.035
4,000	8,000	.0019	.032	150		Set .5259	Set 8.765
6,000	12,000	.0030	.050	26,000	52,000	.7017	11.694
8,000	16,000	.0042	.070	150		Set .6839	Set 11.398
10,000	20,000	.0053	.088	27,000	54,000	1.1930	19.883
12,000	24,000	.0063	.105	150		Set 1.1721	Set 19.535
14,000	28,000	.0073	.122	27,500	55,000	1.3700	22.833
15,000		.0080	.133	24,775	49,550	1.5300	25.500
16,000	32,000	.0086	.143				
150		Set .0008	Set .013				
17,000	34,000	.0094	.157				
150		Set .0012	Set .020				
18,000	36,000	.0102	1.710				
150		Set .0030	Set 1.550				
19,000	38,000	.0128	2.136				
150		Set .0183	Set 1.971				
20,000	40,000	.0177	2.795				
150		Set .0167	Set 2.611				
21,000	42,000	.0191	3.651				
150		Set .0272	Set 3.453				
22,000	44,000	.0213	4.522				
150		Set .0286	Set 4.310				
23,000	46,000	.0366	5.610				
150		Set .0322	Set 5.386				
24,000	48,000	.0443	7.072				

Elastic limit, pounds, per square inch, 34,500.
Modulus of elasticity, 22,286,000.
Modulus of resilience: elastic, 27.60; ultimate, 12,521.
Breaking load per square inch: original section, 55,000; fractured section, 97,200.
Ultimate extension, per cent. of length, 25.50.

ANALYSIS.

	Per Cent.	Per Cent.	
Sulphur.....	0.007	Manganese.....	0.063
Phosphorus...	0.179	Copper.....	0.013
Silicon.....	0.219	Cobalt.....	0.075
Graphite.....	0.008	Nickel.....	0.055
Comb. carbon.	0.049		

TABLE XLII.

Original mark, X. B. iron. No. 1084 B. Dimensions: Length, 6"; diameter, 0.798".

150				22,000	44,000		
2,000	4,000	.0006	.010	150		Set .2772	Set 4.620
4,000	8,000	.0014	.023	23,000	46,000	.3661	Set 4.460
6,000	12,000	.0022	.037	150		Set .3323	Set 5.768
8,000	16,000	.0033	.055	24,000	48,000	.4319	Set 5.538
10,000	20,000	.0042	.070	150		Set .4162	Set 7.181
12,000	24,000	.0051	.085	25,000	50,000	.5565	9.275
14,000	28,000	.0062	.103	150		Set .5398	Set 8.996
16,000	32,000	.0070	.117	26,000	52,000	.7419	12.365
150		Set .0002	Set .003	150		Set .7241	Set 12.066
17,000	34,000	.0167	.278	27,000	54,000	1.4800	24.667
150		Set .0015	Set .025	24,000	48,000	1.6300	27.167
18,000	36,000	.0165	1.775				
150		Set .0969	Set 1.615				
19,000	38,000	.1325	2.208				
150		Set .1223	Set 2.038				
20,000	40,000	.1749	2.915				
150		Set .1636	Set 2.727				
21,000	42,000	.2244	3.740				
150		Set .2122	Set 3.536				

Elastic limit, pounds per square inch, 34,000.
Modulus of elasticity, 26,250,000.
Modulus of resilience: elastic, 22.42; ultimate, 13,360.
Breaking load per square inch: original section, 54,000; fractured section, 94,500.
Ultimate extension, per cent. of length, 27.17.

Plotting these records, we obtain the strain-diagrams, A and B, in the preceding figure, in which the ordinates are measured in pounds per square inch, and the abscissas in per cent. of extension.

The curve is nearly parabolic, but has an irregularity at the start, which marks the elastic limit. The *dark* line is the true curve, and the *light* line is a curve of the sets recorded in the table. Curve A terminates at 25¼ per cent. of stretch. B runs off the plate, and is turned back on itself again for convenience in illustration, ending at 28¼.

Similarly Tables XLIII. and XLIV. are plotted in the succeeding figure. The metal is an "ingot-steel" of excellent tool-steel quality, and of the composition indicated in the tables.

TABLE XLIII.

RECORD OF TESTS BY TENSILE STRESS.

STEEL FURNISHED COMMITTEE ON CHEMICAL RESEARCH.

Original mark, 8 M. B. & P. No. 1072 A. Dimensions: Length, 6"; diameter, .625".

LOADS.		EXTENSIONS AND SETS.		LOADS.		EXTENSIONS AND SETS.	
Actual.	Per sq. inch.	Actual.	Per cent. of length.	Actual.	Per sq. inch.	Actual.	Per cent. of length.
<i>Pounds.</i>	<i>Pounds.</i>			<i>Pounds.</i>	<i>Pounds.</i>		
150				29,000	94,526	.1509	2.515
2,000	6,519	.0017	.028	150	Set	.1166	Set 1.948
4,000	13,038	.0032	.053	30,000	97,785	.1676	2.793
6,000	19,537	.0040	.067	150	Set	.1314	Set 2.190
8,000	26,076	.0058	.097	31,000	101,045	.1867	3.112
10,000	32,595	.0072	.120	150	Set	.1479	Set 2.465
12,000	39,114	.0088	.147	32,000	104,304	.2077	3.462
14,000	45,633	.0103	.172	100	Set	.1671	et 2.785
16,000	52,152	.0119	.198	33,000	107,564	.2356	3.927
18,000	58,671	.0136	.227	150	Set	.1922	Set 3.203
150	Set	.0003	Set	34,000	110,823	.2662	4.437
19,000	61,911	.0143	.238	150	Set	.2266	Set 3.667
150	Set	.0015	Set	30,000	114,083	.3050	5.083
19,100	62,256	.0347	.578	36,000	117,342	.3550	5.917
150	Set	.0180	Set	36,500	118,972	.3800	6.333
20,000	65,190	.0474	.790	37,000	120,602	.4350	7.250
150	Set	.0289	Set	37,500	122,231	.6050	10.083
21,000	68,450	.0509	.948	Elastic limit, pounds per square inch, 61,931.			
150	Set	.0164	Set	Modulus of elasticity, 26,386,000.			
22,000	71,709	.0653	1.088	Modulus of resiliency: elastic, 73.70; ultimate, 10,546.25.			
150	Set	.0430	Set	Breaking load per square inch; original section, 122,231; fractured section, 150,100.			
23,000	74,969	.0755	1.258	Ultimate extension, per cent. of length, 10.08.			
150	Set	.0522	Set				
24,000	78,228	.0868	1.447				
150	Set	.0675	Set				
25,000	81,488	.0964	1.607				
150	Set	.0699	Set				
26,000	84,747	.1090	1.817				
150	Set	.0804	Set				
27,000	88,007	.1212	2.020				
150	Set	.0920	Set				
28,000	91,266	.1367	2.278				
150	Set	.1043	Set				

ANALYSIS.			
	Per Cent.		Per Cent.
Sulphur	None.	Manganese	0.245
Phosphorus	0.019	Copper	trace.
Silicon	0.157	Cobalt	trace.
Graphite	0.008	Nickel	None.
Comb. carbon	0.984		

TABLE XLIV.

RECORD OF TESTS BY TENSILE STRESS,

STEEL FURNISHED COMMITTEE ON CHEMICAL RESEARCH.

Original mark, 8 M. B. & P. No. 1072 B. Dimensions: Length, 6''; diameter, .625''.

LOADS.		EXTENSIONS AND SETS.		LOADS.		EXTENSIONS AND SETS.	
Actual.	Per sq. inch.	Actual.	Per cent. of length.	Actual.	Per sq. inch.	Actual.	Per Cent. of length.
<i>Pounds.</i>	<i>Pounds.</i>			<i>Pounds.</i>	<i>Pounds.</i>		
150	150	Set .0912	Set 1.520
2,000	6,519	.0017	.028	27,000	88,007	.1343	2.238
4,000	13,038	.0029	.048	28,000	91,266	.1497	2.495
60,000	19,557	.0044	.073	150	Set .1166	Set 1.743
8,000	26,076	.0057	.095	29,000	94,526	.1665	2.775
10,000	32,595	.0072	.120	150	Set .1316	Set 2.193
12,000	39,114	.0085	.142	30,000	97,785	.1850	3.083
14,000	45,633	.0100	.167	31,000	101,045	.2060	3.433
16,000	52,152	.0116	.193	150	Set .1676	Set 2.793
17,000	55,412	.0124	.207	32,000	104,304	.2331	3.885
18,000	58,671	.0180	.300	150	Set .1911	Set 3.185
150	Set .0044	Set .073	33,000	107,564	.2633	4.388
18,400	59,975	.0189	.315	150	Set .2190	Set 3.650
18,500	60,301	.0443	.738	34,000	110,823	.3025	5.042
150	Set .0268	Set .447	150	Set .2555	Set 4.258
19,000	61,931	.0484	.807	35,000	114,083	.3554	5.923
150	Set .0304	Set .507	150	Set .3067	Set 5.112
20,000	65,190	.0560	.933	36,000	117,342	.4300	7.167
150	Set .0368	Set .613	150	Set .3823	Set 6.372
21,000	68,450	.0657	1.095	37,000	120,602	.6650	11.083
150	Set .0448	Set .747	35,500	118,972	.7825	13.042
22,000	71,709	.0754	1.257	Elastic limit, pounds per square inch, 59,975.			
150	Set .0532	Set .887	Modulus of elasticity, 27,416,000.			
23,000	74,969	.0866	1.443	Modulus of resilience: elastic, 94.46; ultimate, 11.375.			
150	Set .0623	Set 1.038	Breaking load per square inch: original section, 120,602; fractured section, 147,000.			
24,000	78,228	.0970	1.617	Ultimate extension, per cent. of length, 13.04.			
150	Set .0711	Set 1.185	Permanent extension or set, per cent. of length, measured from broken test-piece, 10.08.			
25,000	81,488	.1080	1.800				
150	Set .0806	Set 1.343				
26,000	84,747	.1205	2.083				

Plotting these records, we obtain a diagram characteristicly different from the preceding. The elastic limit has risen to the ultimate strength of those just described; the tenacity is about double, and the ductility vastly less. The elastic resilience is proportionally increased, but the ultimate resilience is rather less. All observations are indicated by dots. These curves will be frequently alluded to later.

On comparing the curve of the strain-diagram with the curve of sets, it is seen that the latter lies outside the former throughout, as it evidently should, and that sets may occur far within the "elastic limit," and probably quite down to the starting-point—the origin of the curve. This corrobora-

tion of Hodgkinson's deduction, that every load, however small, produces a set, is more conclusively exhibited in the

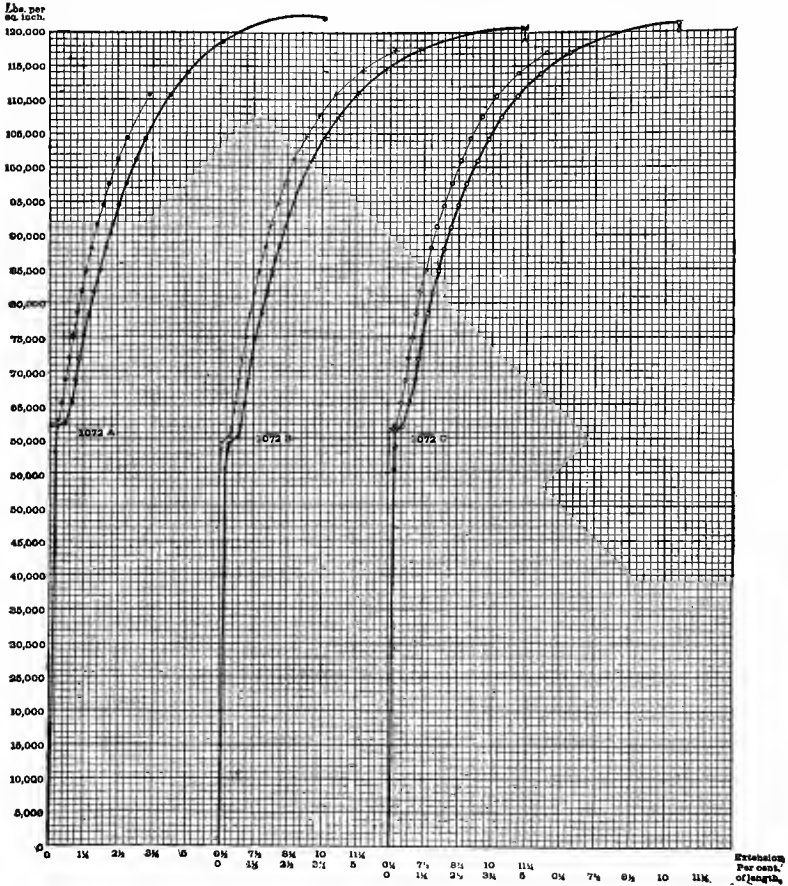

FIG. 61.—STRAIN-DIAGRAMS OF INGOT-STEEL.

autographic diagrams to be given, on some of which the Author has obtained a record of sets nearly at the origin. The "elasticity lines" of these curves will also be found to be invariably steeper than the initial line of the diagram, whether taken within or without the elastic limit; which fact is also probably conclusive of the same deduction.

It is seen that, within the elastic limit, both sets and elongations are proportional to the loads, that the same is true on any elastic line, and that loads and elongations are nearly proportional everywhere beyond the elastic limit, within a moderate range, although the total distortion then bears a far higher ratio to the load, while the sets become nearly equal to the total elongations.

206. Effect of Shock or Impact; Resilience.—The behavior of iron or steel under moving or “live” load and under shock is not the same as when gradually and steadily strained by a slowly applied or static stress. In the latter case the metal undergoes the changes illustrated above by the strain diagrams given until a point is reached at which equilibrium occurs between the applied load and resisting forces, and the body rests indefinitely, as under a permanent load, without other change occurring than such settlement of parts as will bring the whole structural resistance into play.

When a freely moving body strikes upon the resisting piece, on the other hand, it only comes to rest when all its kinetic energy is taken up by the resisting piece; there is then an equality of *vis viva* expended and work done, which is expressed thus:

$$\frac{WV^2}{2g} = \int_0^s p \, dx = p_m s;$$

in which expression W is the weight of the striking body, V its velocity, p the resisting force at any instant, p_m the mean resistance up to the point at which equilibrium occurs, and s is the distance through which resistance is met.

As has been seen, the resistance may usually be taken as varying approximately with the ordinates of a parabola, the abscissas representing extensions. The mean resistance is, therefore, nearly two-thirds the maximum, and

$$\frac{WV^2}{2g} = \int_0^s p \, dx = p_m s = \frac{2}{3} et = ae^2, \text{ nearly; } \dots (8)$$

where e is the extension, and t the maximum resistance at

that extension, and a a constant. Brittle materials, like hard cast iron and very hard-tempered steel, have a straight line for their strain-diagrams, and the coefficient becomes $\frac{1}{2}$ instead of $\frac{2}{3}$, and

$$\frac{WV^2}{2g} = ae^2 = \frac{1}{2}et = \frac{1}{2} \frac{t^2}{E} \dots \dots (9)$$

207. Resilience, or Spring, is the work of resistance up to the elastic limit. This will be hereafter called *Elastic Resilience*, measuring resistance to shock in any case. The modulus of elasticity being known, the Modulus of Elastic Resilience is obtained by dividing half the square of the maximum elastic resistance by the modulus of elasticity, E , as above, and the work done to the primitive elastic limit is obtained by multiplying this modulus of resilience by the volume of the bar.*

The total area of the diagram, measuring the total work done up to rupture, will be called a measure of *Total* or *Ultimate Resilience*. Mallet's Coefficient of Total Resilience is the half product of maximum resistance into total extension. It is correct for brittle substances and for all cases in which the primitive elastic limit is found at the point of rupture. With tough materials, the coefficient is, as stated above, more nearly two-thirds. Unity of length and of section being taken, this coefficient is here called the Modulus of Resilience.

When the energy of a striking body exceeds the total resilience of the material the piece will be broken. When the energy expended is less, the piece will be strained until the work done in resistance equals that energy, when the body will be brought to rest.

As the work of resistance is partly due to the inertia of the particles of the resisting piece, the strain-diagram area is always less than the real work of resistance, and, at high velocities, may be very considerably less, the difference being expended in deforming that part of the piece at which the blow is received. In predicting the effect of a shock, it is

* Rankine and some other writers take this modulus as $\frac{t^2}{E}$, instead of $\frac{1}{2} \frac{t^2}{E}$.

therefore necessary to know not only the energy stored in the moving mass and the method of variation of the resistance, but also the striking velocity. To meet a shock successfully it is seen that resilience must be secured sufficient to take up the shock without rupture, or, if possible, without serious deformation. It is usual, and in most cases necessary, to make an *elastic* resilience greater than the maximum energy of any attacking body. Toughness, rather than simple tenacity, is the essential quality, and, for this reason, weld or ingot iron, not hard steel, is chosen for the armor-plate and armor-bolts of iron-clads and spring-tempered steel for parts of machinery exposed to shock.

Moving Loads produce an effect intermediate between that due to static stress and that due to the shock of a freely moving body acting by its inertia wholly; these cases are, therefore, met in design by the use of a higher factor of safety, as above. In any case the work of both the attacking and the resisting body should be calculated when possible, and the factor of safety applied as in meeting static stress.

As is seen by a glance at the strain-diagram *ff* (Fig. 59), the piece once strained has a higher elastic resilience than at first, and it is therefore safer against permanent distortion by moderate shocks, while the approach of permanent extension to a limit renders it less secure against shocks of such great intensity as to endanger the piece.

When the shock is completely taken up the piece recoils, as at $e''f''f''$, until it settles at such a point on that line—assuming the shock to have extended the piece to the point e'' —that the static resistance just equilibrates the static load. This point is usually reached after a series of vibrations on either side of it has occurred. With perfect elasticity this point is at one half the maximum resistance or elongation attained. Thus we have

$$\int_0^x p \, dx = \frac{WV^2}{2g}; \quad \dots \dots \dots (10)$$

but p varies as x within the elastic limit, which limit has now

risen to some new point along the line of normal elastic limits, as e^v . Taking the origin at the foot of $f''f''$, since the variations of length along the line Ox are equal to the elongations and to the distances traversed as the load falls; and as stresses are now proportional to elongations,

$$p = ax; Wh = Ws; \text{ and } W = P \quad \dots \quad (11)$$

when the resisting force is p , the elongations x , while h and s are maximum fall and elongation, and P is the maximum resistance to the load at rest. Then

$$\int_0^s p \, dx = a \int_0^s x \, dx = \frac{a}{2} s^2 = Ws \quad \therefore s = \frac{2W}{a} \quad \dots \quad (12)$$

For a static load, if s' is the elongation,

$$W = P = as' \quad \therefore s' = \frac{W}{a}.$$

Hence, $\frac{s'}{s} = \frac{1}{2} \quad \dots \quad \dots \quad (13)$

and the extension and the corresponding stress due to the sudden application of a load are double those produced by a static load.

Where the applied load is a pressure and not a weight, *i. e.* where considerable energy in a moving body is not to be absorbed, as in the action of steam in a steam engine, the only increase of strain produced by a suddenly applied load is that produced by the inertia of such of those parts of the mass attacked as may have taken up motion and energy. This latter case is illustrated by the surging of the cables of a suspension bridge in a high wind. This action may become dangerous, and has caused the fall of large bridges and other important structures.

Tetmajer* would classify metals by the value of their work of ultimate resistance, or "working capacity," *i. e.*, as

* Eisenbahn, Zurich, Oct. 15, 1881, p. 92; Abstracts of Papers, Inst. C. E., LXVI., LXVII., pp. 58; 22.

the Author calls it, "ultimate resilience," as measured by

$$w = aTe \quad (14)$$

the product of a factor, *a*, for each piece, into the ultimate tenacity, *T*, and the elongation, *e*, for the unit of measure. When *T* is in pounds per square inch, or kilogrammes per square centimetre, and *e* in per cent. the value of

$$c = \frac{w}{a} = Te \quad (15)$$

is a measure of the value of the metal, thus :

If iron has a tenacity of 50,000 pounds per square inch (3,515 kilogrammes per square centimetre), and elongates 0.20, the value of *Te* is 10,000 foot-pounds (703 kilogrammetres) per unit of length and of section.

The following are the standard values for standard classes, as proposed :

A. PUDDLED IRON.		
Class.	<i>c</i> : Pounds × per cent.	<i>c</i> : Tonnes × per cent.
I.....	9,750	68
II.....	6,850	48
III.....	4,850	34
IV.....	3,425	24
B. MALLEABLE CAST METAL (IRON OR STEEL).		
I.....	12,250	93

The specifications would demand metal having at least the above value of *c*, and a tenacity exceeding, say :

Rivet iron.....	55,000 lbs. per sq. in. (3.6 tonnes per sq. cm.).
Bar iron.....	55,000 " " " " (3.6 " " " ").
Steel rails or tires..	70,000 " " " " (4.9 " " " ").
Steel boiler plate..	60,000 " " " " (4.2 " " " ").

208. Proportioning to resist Shock.—The problem of proportioning parts to resist shock is thus seen to involve a determination of the energy, or "living force," of the load at impact, and an adjustment of proportion of section and shape of piece attacked such that its work of elastic or of

ultimate resilience, whichever is taken as the limit, shall exceed that energy in a proportion measured by the factor of safety adopted. For ordinary live loads and moderate impact, requiring no specially detailed consideration, the factors of safety already given (Art. 199), as based upon ultimate strength simply, are considered sufficient; in all cases of doubt, or when heavy shock is anticipated, calculations of energy and resilience are necessary, and these demand a complete knowledge of the character, chemical, physical and structural, of every piece involved; of its method of resilience and of yielding under stress, and of every condition influencing the application of the attacking force—in other words, a complete knowledge of the material used, of the members constructed of it, and of the circumstances likely to bring about its failure.

The form of such parts should usually be determined on the assumption that deformation may some time occur, and such expedients as that of Hodgkinson in enlarging the section on the weaker side, as well as the adoption of a larger factor of safety based on ultimate strength, are advisable.

209. Value of Iron and Steel as shown by Strain-Diagrams.—The accompanying set of strain-diagrams may be taken as representative of the behavior of good samples of the various grades of wrought iron and of steel above described.

The diagrams *a a*, *b b*, *c c*, are those of commercial irons of good quality, soft, medium and hard respectively, and all of high ductility. * The elastic limits of *a* and *b* differ greatly in position, and the irons themselves are characteristically different. The one is in a condition of initial internal strain which has weakened it against external stresses; but, that strain being relieved by flow under strain, the iron is finally found to be stronger than the second piece.

It is evident that the first is less valuable than the second, however, under any stresses that occur within the usual limits of distortion; the engineer would choose *b* as having a higher elastic limit and much greater elastic resilience.

The "elasticity line," *e' e'*, shows the amount of spring and of set at the point at which it is taken, and gives a

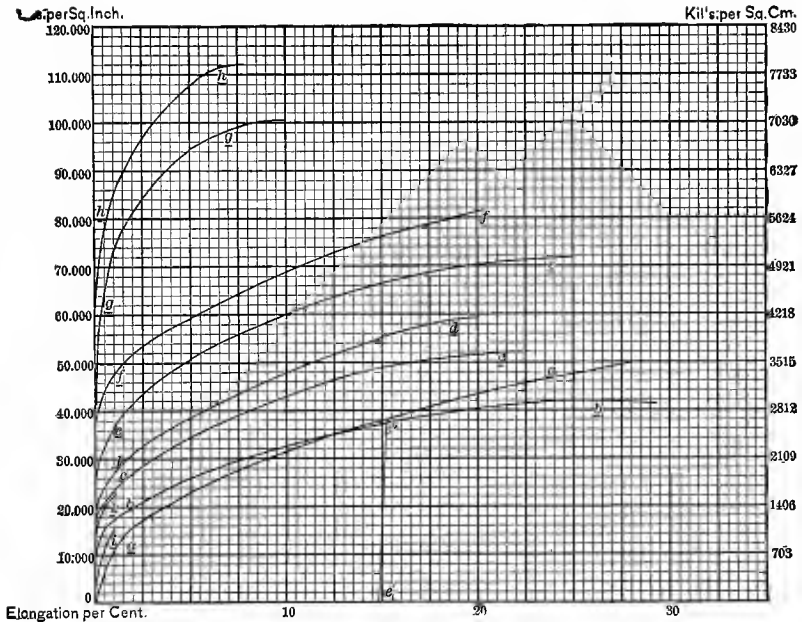

FIG. 62.—STRAIN-DIAGRAMS OF IRON AND STEEL.

measure of the modulus of elasticity. The harder iron, *dd*, is probably actually a puddled steel, and has been made by balling up the sponge in the puddling furnace too early to permit complete reduction of carbon. The gradual increase in strength, with increase of carbon, and rise of the elastic limit, are shown, as well as the coincident loss of ductility, in the diagrams, *e*, *f*, *g*, and *h*, which are those of steels containing from 0.35 to 1 per cent. carbon; *e* and *f* are the diagrams from excellent samples of the product of the open-hearth and pneumatic processes, and the stronger specimens are representatives of the average crucible steel.

The increase of resilience within the elastic range is seen to be very great as the percentage of carbon is increased.

210. Chemical Composition of Iron and Steel.—*Iron.*—This determines the real character of any sample, although differences of physical character and of molecular structure often seriously modify the value of pieces into the composi-

tion of which they enter. With cast metal, where sound castings have been secured, the chemical constitution of the metal being known from analyses, the value of the metal for purposes of construction may be usually well judged; and a comparison of the data given by the chemist, with the specific gravity of the metal, will generally be sufficient to determine its character with great exactness. Specifications for cast iron or cast steel may usually be safely so drawn as to make the acceptance of the material dependent upon accordance with specified formulas of composition and density.

Thus: A good, gray foundry iron, free from phosphorus and low in silicon, and having a density of 7.25 to 7.28, is, unless containing some peculiar and unusual constituent in excess, a safe iron to use for all purposes demanding strength. Wrought iron and "mild" steels are, on the other hand, so greatly modified by the processes of preparation in the mill, that actual test can only be safely depended upon to determine their value in construction.

Statements of the strength of iron or steel are not of great value in any case, when the metal of which the strength or ductility is given is specified by its trade or generic name simply without a statement of its precise chemical composition and physical character. Wrought iron varies in composition and in structure to such an extent that, while the softest and purest varieties often have a tenacity of but about 40,000 pounds per square inch (2,812 kilogrammes per square centimetre), some so-called wrought irons (properly puddled steels) have been met with by the Author in the market having a tenacity of double that figure; some samples extend 25 per cent. before breaking, while others, with similar shape and size of test-piece, are found nearly as brittle as cast iron.

Cast iron varies in tenacity from as low as 10,000 pounds per square inch (703 kilogrammes per square centimetre) to more than 50,000 pounds (3,515 kilogrammes per square centimetre); while metals are sold under the name of "steel" having tenacities varying from that of wrought iron up to over 100 tons per square inch (15,746 kilogrammes per square centimetre).

In the examples of results of tests of iron and steel which will be hereafter given, therefore, the character of the metal tested will usually be exactly defined by its chemical composition.

In comparing the results of test with the chemical constitution of the material, it will be found that, in general, elements which increase tenacity also decrease ductility and resilience.

Thus: carbon increases strength up to a limit beyond which an excess begins to weaken it, as at the limit which separates steel from cast iron; but every addition of strength takes place at the sacrifice of that ductility which is an essential property of good iron.

Phosphorus adds strength, as do manganese and other less common constituents; but, in each case, a limit to increasing strength is reached, and, in each case, the increase of strength noted is accompanied by an equally or more noticeable loss of ductility. It sometimes happens, however, that the elastic resilience increases, with addition of such elements, up to a limit; which limit is, however, reached long before the increase of strength ceases.

Composition of Steels.—The influence of the most common hardening elements upon the valuable qualities of "rail-steel" and similar metals has not been studied sufficiently to determine their precise effect and their modifying action as mutually reacting upon each other. The hardening elements most usually met with in iron and steel are carbon, silicon, manganese, and phosphorus. Dr. Dudley* takes the effect of manganese, carbon, silicon, and phosphorus, to be as the numbers 3, 5, $7\frac{1}{2}$, and 15, and reckons the sum of their effects in "phosphorus units" on this basis, allowing 0.05, 0.03, 0.02, and 0.01 per cent. respectively of these elements, taken in the order just given, as each equivalent to one unit. He concludes that the sum should not exceed 31 or 32 in rails and other soft ingot-metals, this figure being obtained, as above, by adding together the phosphorus percentage, one-half the silicon, one-third the carbon, and one-fifth the manganese. Taken singly,

* *Trans. Am. Inst. Mining Eng'rs*, Vol. VII.

the limit for phosphorus is placed at a maximum of 0.10 per cent., silicon at 0.04, manganese at 0.30 or 0.40, and, for such metals, carbon at 0.25 to 0.30 per cent. Higher proportions make the material too brittle for rails and similar uses.

Dr. Dudley concludes from these and from subsequent researches that, in the torsion tests, the slower wearing rails in each group, except, perhaps, on the high sides of curves, are characterized in general by lower height and greater length of diagram. In the tensile tests, the slower wearing rails are, in general, characterized by lower tensile strength and greater elongation than the more rapidly wearing ones. In the shearing tests, the same thing appears, viz., in general, lower shearing stress and greater abrasion. And in the bending tests we see the same result, perhaps more strongly than in any of the other tests, viz., that the slower wearing rails are, in general, those which have the lower bending stress and the greater amount of deflection before rupture. In density, the slower wearing rails have the greater density. Again, in the chemical composition, the slower wearing rails are characterized in general by the lower amounts of the substances determined, carbon, phosphorus, silicon, and manganese, while in phosphorus units the same thing may be seen, viz., in general, the slower wearing rails are characterized by the presence of lower numbers of phosphorus units. Further investigation is needed to determine the validity of these conclusions.

Steels containing more carbon are still more carefully chosen with a view to the avoidance of the loss of ductility due to the action of other elements in presence of carbon.

Manganese steels, *i. e.*, steels containing a high percentage of manganese, having but little carbon or other of the hardening elements, are found to have peculiar value for many purposes of construction; but their use must be carefully avoided in steam boilers, or elsewhere, when exposed to great and rapid changes of temperature.

211. Modifying Conditions.—The chemical composition of cast iron will usually, and especially if checked by a determination of density, serve well as a guide to the selection of

iron of any specified character for use in construction ; yet it is always advisable to supplement the analysis by the determination of its physical characteristics as revealed by inspection and by test. The openness or closeness of grain, the shade of color, the depth of chill, and other properties capable of detection by the senses, are valuable guides to the experienced engineer.

The same is true of all forms of ingot metal, whether worked or unworked. Steels are selected by visual inspection with great accuracy and certainty, but the engineer usually desires to compare the chemist's analysis with the results of mechanical tests, as well as to obtain the judgment of the steel-maker who inspects the topped ingots.

The products of the pneumatic and of the open-hearth processes are now customarily tested both by the chemist's and by physical tests.

The influence of mechanical treatment during the process of manufacturing wrought iron and puddled steel—the "weld" metals—is very great in the modification of their valuable properties. This is the case to such an extent that the quality of these materials can but rarely be safely judged from chemical analysis. The presence or absence of cinder, the amount of reduction in the rolls or under the hammer, and the temperature and other conditions of working, are circumstances that modify quality to such an extent as usually, with the better kinds of metal, to entirely obscure variations due to accidental differences in chemical constitution ; with other irons and steels both sets of conditions concur to determine quality. It is never safe, therefore, to base specifications for these materials upon chemical composition alone ; actual test is usually demanded as a basis for their acceptance or rejection.

212. Internal Stress and Strain.—The tests made to determine the character of any material are not decisive, even when the chemical composition and the general physical character are also known, unless the effects of various modifications of external condition and of molecular relations are also ascertained. The influence of heat and cold, time of exposure to stress and other external conditions will be

discussed hereafter. Internal molecular conditions are modified, in some cases, to a very important degree by peculiar conditions of manufacture. Such changes often take effect in the production of *internal stresses* coming of internal strains consequent upon, for example, too rapidly cooling an irregularly shaped, or a massive, casting, or that internal flow under strain which accompanies the forging or rolling of malleable metals.

Such internal strains often so weaken large or badly shaped iron castings that they break without other external stress than such as comes of their change of temperature when lying in the sun, or they may even break when lying undisturbed in their moulds. Large castings are never expected by the engineer to exhibit the strength of small ones, and large sections of wrought iron and of steel exhibit a smaller tenacity than small bars. A wrought-iron bar five inches in diameter has been broken under a load of 36,000 pounds per square inch (2,531 kilogrammes per square centimetre), when a rod one inch (2.54 centimetres) square of the same material sustained 60,000 (4,218 kilogrammes per square centimetre), and wire of the same quality, but reduced to one-tenth the latter section, exhibits a tenacity still higher by one-third. These differences are partly due, probably, to the fact that even wire is chemically purified by heating and working; but they are also largely due to differences in the extent to which internal strains modify resisting power.

It is evident that materials, to be acceptable to the engineer, must be homogeneous as to internal strain as well as in physical and chemical structure.

213. The Methods of Testing to determine the strength, and of determining other valuable qualities of iron and steel, are like those generally adopted for other materials of construction:—First, the direct measurement of strength and ductility, by subjecting the material, in some convenient and usually standard form, to stresses easily and accurately measurable. Secondly, the determination of other qualities, as the behavior of the metal when worked cold or hot, its welding power, or its qualities as exhibited when made into tools.

Frequently, a determination of the influence of form upon its resisting power, or of its behavior in large sections as part of a complete structure, is considered essential. These last tests are applied to selected specimens which are taken as representative of the whole lot, except where the tests are made to determine the behavior of the metal within the primitive elastic limit, or within a defined working limit. In this latter case, the tests determine, to a certain extent, the character of pieces actually used, and such tests should be made whenever possible.

When the general character of the material is well known, tests within the elastic limit may reveal with certainty and accuracy all that the engineer desires to know. The elastic properties of the metal are, in such cases, well determined, and if any serious defect exists, the consequent exceptional value of the modulus of elasticity, or the peculiarities of the initial part of the strain-diagram, will exhibit the fact of its presence, and lead to the rejection of the piece. Those tests which are thus made on parts intended for use are of peculiar value, and should always be made by the engineer when practicable. (See *Trans. A. S. Mech. Engrs.*, Vol. XI., p. 604.)

In making tests of iron and steel it is customary to employ "*Testing-Machines.*" Tests of transverse strength of bars, beams, and girders, are sometimes made by supporting them properly at each end, and applying known weights at the middle. Completed structures, as bridges, are tested by a load exceeding the heaviest that can be expected to come upon them in regular work, and their final acceptance or rejection is made to depend upon the result of this trial. As every variation of form and size of piece, as well as of physical and chemical character, causes a variation in strength, elasticity, and resilience of the piece tested, it is necessary, to determine the influence of such modifications, to make standard forms and dimensions of test-piece, where testing for quality simply, and to modify specifications so as to allow for such differences in proportioning the dimensions of parts of structures. The tests of small specimens may be of great value in determining the character of materials used, when the

extent of modification, which is produced by change of form and dimensions, is well understood; but such tests may be fatally misleading in the absence of such knowledge.

214. Testing Machines are used for testing small sections and pieces of moderate length. They are usually built by manufacturers who make a business of supplying them to engineers and other purchasers, and are generally made of several standard sizes. The machine is frequently fitted up to test both longitudinally and transversely; although the tests generally made are in but one direction.

215. Riehle's Machine.—The Author has been accustomed to keep in use a machine specially intended to test in tension and compression, and also separate machines for transverse and torsional tests.

The *Tension-Machine* is a modified form of that shown in Fig. 63. The design is peculiar; it consists of two strong cast-iron columns, secured to a massive bed frame of the same material; above these columns is fastened a heavy cross-piece, also of cast iron, containing two sockets, in which rest the knife-edges of a large scale-beam. The upper chuck is

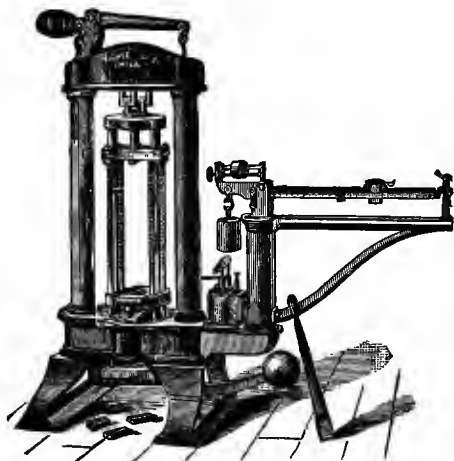

FIG. 63.—TENSION TESTING MACHINE.

suspended by eye-rods from two knife-edges, $\frac{1}{2}$ inch to one side of centre of a heavy wrought iron block, which is hung by two links from two pairs of knife-edges projecting from the scale-beam on opposite sides of the knife-edges of the latter, and at equal distances from them, the whole making a very powerful beam combination. All the knife-edges are of tempered

steel, and the sockets and eyes are lined with the same ma-

terial, thus reducing friction to a minimum. The load is applied by means of a hydraulic press, with a fixed plunger and movable cylinder; to the latter the lower chuck is fastened by means of an adjustable staple and link. The stress to which the test-piece is subjected is measured by means of suspended weights and a sliding poise. The specimen is secured in the chucks either by wedge-jaws or bored chucks.

The machine shown in the figure has a set of levers, like those used in heavy scales, in place of the "differential beam" preferably used by the Author.

The extensions are measured by means of an instrument, Fig. 64, in which contact is indicated by an "electric contact apparatus." This instrument consists of two accurately made micrometer screws, working snugly in nuts secured in a frame which is fastened to the head of the specimen by a screw clamp. It is so shaped that the micrometer screws run parallel to and equidistant from the neck of the specimen on opposite sides. A similar frame is clamped to the lower head of the specimen, and from it project two insulated metallic points, each opposite one of the micrometer screws. Electric connection is made between the two insulated points and one pole of a voltaic cell, and also between the micrometer screws and the other pole. As soon as one of the micrometer screws is brought in contact with the opposite insulated point a current is established, which fact is immediately revealed by the stroke of an electric bell placed in the circuit. The pitch of the screws is 0.02 of an inch (0.508 mm.), and their heads are divided into 200 equal parts; hence a rotary advance of one division on the screw-head produces a linear advance of one ten-thousandth (0.0001) of an inch (0.00254 mm.).

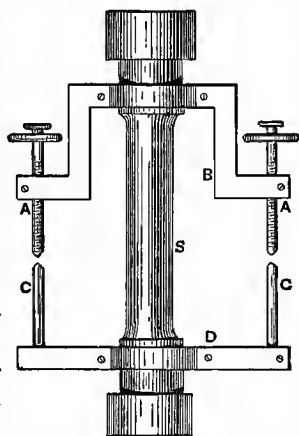

FIG. 64.—MEASURING INSTRUMENT.

A vertical scale, divided into fiftieths of an inch (0.508 mm.), is fastened to the frame of the instrument, set very close to each screw-head and parallel to the axis of the screw; these serve to mark the starting point of the former, and also to indicate the number of revolutions made. By means of this double instrument the extensions can be measured with great certainty and precision, and irregularities in the structure of the material, causing one side of the specimen to stretch more rapidly than the other, do not diminish the accuracy of the measurements, since half the sum of the extensions indicated by the two screws is always the true extension caused by the respective loads.

The use of the hydraulic press is occasionally found to bring with it some disadvantages. The leakage of the press or of the pump is itself objectionable, and, where leakage occurs, it is difficult to retain the stress at a fixed amount during the time required in the measurement of extensions. In such cases absolute rigidity in the machine is important.

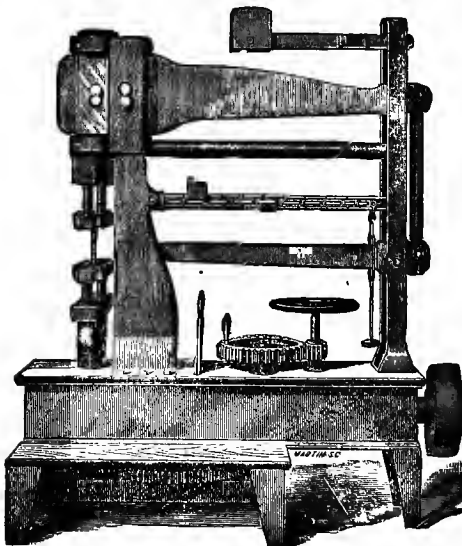

FIG. 65.—GILL'S TESTING MACHINE.

Machines have been designed in which the stress is applied by mechanism, which usually consists of a train of gearing operated by hand or by power transmitted from some prime mover, and itself operating a pulling or compressing screw. The author has used a machine of this character, which is illustrated in the next engraving.

216. Gill's Machine.—The stress is applied in this machine either by hand or by a belt leading to the pulley at the

right, and a lever placed at the left of the hand wheel transfers the connection to one or the other mechanism as required, by operating a friction-clutch. The stress is transmitted through a large screw, at the left, to the specimen, and through the latter a series of levers to the weigh-beam which carries two adjustable weights—sliding poises—by means of which the alterations of the load are accurately and conveniently measureable up to 10,000 pounds per square inch (703 kilogrammes per square centimetre). A stirrup at the right carries weights which are added, 10,000 pounds (4,536 kilogrammes) at a time, as the stress is increased, the sliding poises being used to produce intermediate loads.

In this machine the weighing-head is kept exactly in line by cylindrical guides, of which the bearings and those of the pulling-head are finished at one operation by the boring arbor of the boring machine.

217. Olsen's Machine.—The next Testing Machine is of

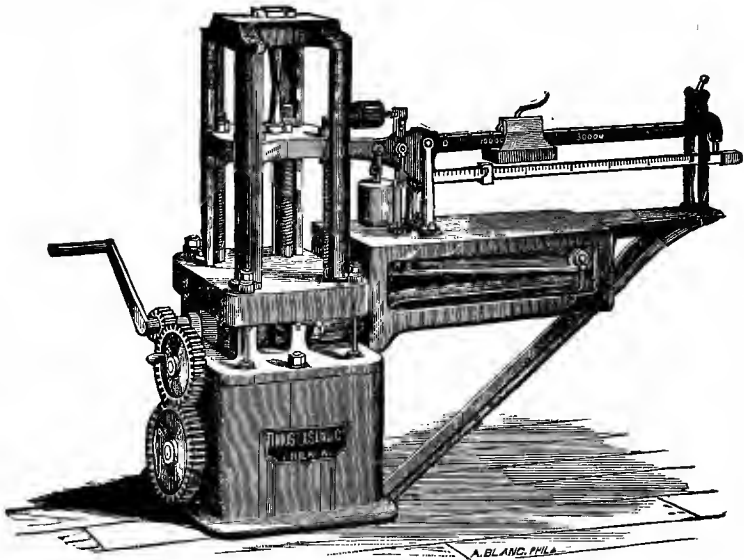

FIG. 66.—THE OLSEN TESTING MACHINE.

the same class as the machine just described. It consists

(Fig. 66) of a heavy base containing the gearing required to turn the straining screws, which pull downward a pulling-head in which the lower end of the test-piece is secured. The upper end of the piece is made fast in an upper pulling-head which is supported on four standards, which receive the stress as a thrust, and transmit it to the base through a strong beam which is connected in turn by levers to the weighing beam, where the stress is measured by the adjustment of two sliding poises—one for heavy loads, the other for smaller amounts. Special devices are ingeniously fitted for holding test-pieces.

218. Emery's Machine.—Very heavy machines have been constructed capable of testing metals under stresses measured by hundreds of tons. Such machines are usually hydraulic presses so arranged that the load may be determined by reference to a pressure-gauge which measures the pressure of the liquid within the press. With such machines the results are not usually to be accepted as more than fairly approximate.

An amount, which may usually be taken as nearly $\frac{20}{d}$ per cent., is to be deducted from the recorded load for friction of plungers, d being the diameter in inches ($\frac{1}{2d}$ for the diameter in metres). In some cases a set of levers is added even to very large machines, to weigh the loads. Such machines are used by Kirkaldy, Styffe, Bauschinger, and other distinguished investigators, and a large proportion of recorded work has been done upon testing machines of this class.

The work of the United States Board appointed to test iron, steel, and other metals (1875-9), was principally carried on in the Washington Navy Yard and in the Mechanical Laboratory of the Stevens Institute of Technology, on machines of the class illustrated above. That Board, however, constructed a very large and wonderfully accurate machine, designed by A. H. Emery, on which to determine the strength of large sections and parts of structures. It has been tested up to stresses of 1,000,000 pounds (453,600 kilogrammes).

This machine (Frontis.) consists of a hydraulic press,

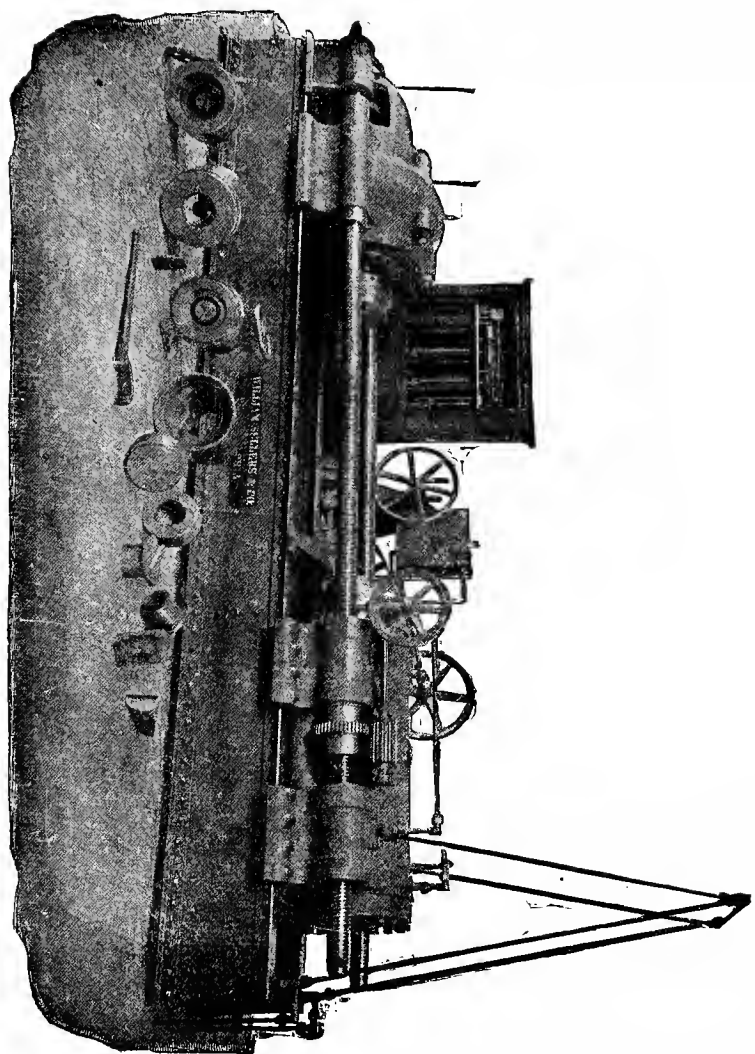

FIG. 66a.—EMERY (200,000-LB.) TESTING-MACHINE OF SIBLEY COLLEGE, CORNELL UNIVERSITY.

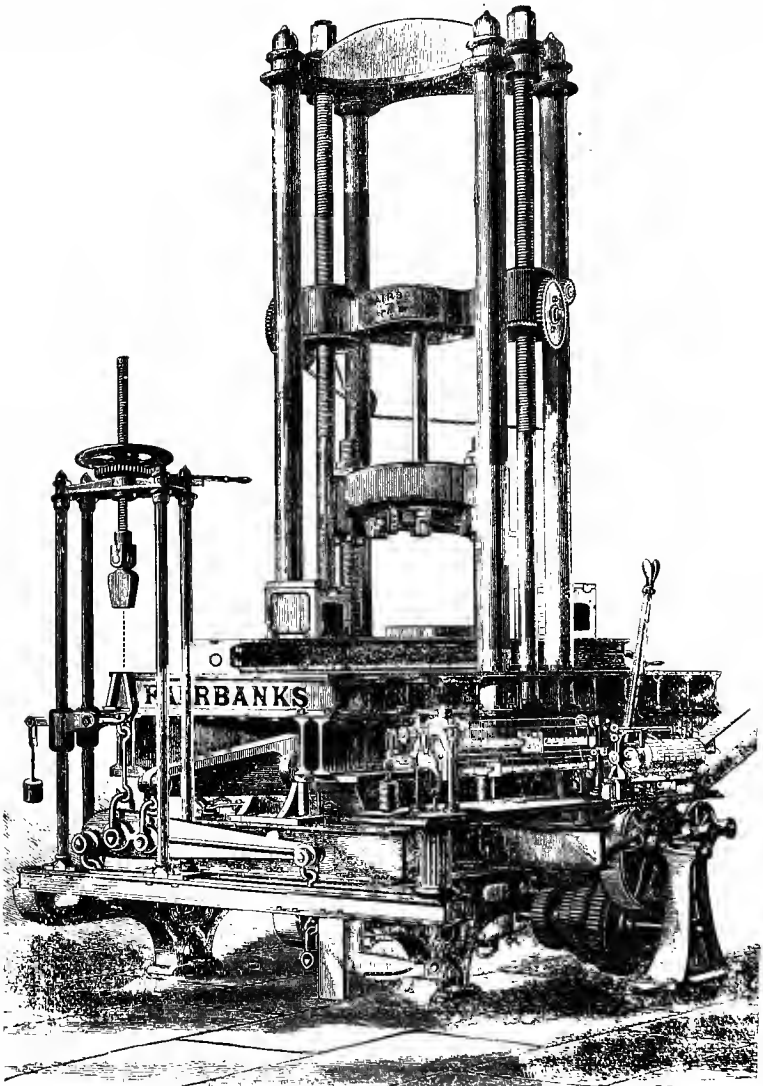

FIG. 67.

which is adjustable within a certain range, as to distance, from the weighing apparatus fixed at one end of the machine, the two being connected by a pair of screws 8 inches (20.32 centimetres) in diameter, and 48 feet (14.8 metres) long, and so arranged that specimens from 1 inch (2.54 centimetres) to 30 feet (9 metres) long, and in width as great as 30 inches (0.75 metres) can be tested. The position of the straining-head is given it by a set of bronze nuts fitted to the screws and traversing with the hydraulic press, their motion being given them by a belt leading from a line of shafting driven by a small steam engine, which also drives the pumps. The stresses are measured by scale-beams to which they are transmitted through a set of diaphragms and cells containing a mixture of alcohol and glycerine, and which operates as a frictionless reducing mechanism. The movement of the indicating pointer is 420,000 times as great as that of the head receiving and transmitting the stress. The machine is practically frictionless, and is, consequently, once standardized, almost absolutely accurate. No knife-edges are used; all points of junction in the weigh beams are, instead, fitted with thin sheets of steel capable of spring to the extent that a beam usually turns on its knife-edge without nearly approaching the elastic limit. There is thus secured entire immunity from losses due to friction or imperfection of knife-edges. The pumps supply the press through an accumulator, to avoid liability to shock transmitted from them.

The whole machine is mounted upon a heavy and deep foundation.

Among the tests made before acceptance by the Board were the following :

A link of hard wrought iron, 5 inches (12.7 centimetres) in diameter between the eyes, was slowly strained in tension, and broke at 722,800 pounds (328,000 kilogrammes). The diameter before breaking at the point of fracture was 5.04 inches (12.8 centimetres); after breaking, 4.98 inches (12.6 centimetres).

A horse-hair was next tested; $\frac{7}{10000}$ ths of an inch (0.17 millimetre) in diameter; it stretched 30 per cent., and broke

at 1 pound (0.45 kilogramme). Other horse-hairs varied in tenacity between one and two pounds.

218 a. The Fairbanks Testing Machine.—The cut on the opposite page gives an illustration of a "Lever Testing Machine," by Fairbanks & Co.

The machine has a large rectangular platform, 10 feet (3.0 m.) by 4 feet (1.2 m.); and the accuracy of the machine may at any time be tested by placing standard weights upon this platform.

The machine is adapted for making tests in tension, compression, and transverse stress, up to 200,000 lbs. (90,720 kilogs.), and up to 12 feet (3.7 m.) in length. It also has appliances for applying shearing, bulging, punching, and torsional stresses.

The jaws for holding specimens are so arranged that the ordinary rolled shapes, such as angles, channels, I-beams, etc., can be placed in the machine, and broken in full size, whether by tension, compression or transverse stress. By means of this provision in the design of the machine, it is possible to arrive at the actual strength of all rolled shapes very satisfactorily.

On the end of the beam-shelf there may be seen a small cylinder, carrying a sheet of cross-section paper. The weighing apparatus of the testing machine is so arranged that the action of the machine is entirely automatic. The beam forms an automatic shunt, such that, as it rises or falls, the current from a battery is shunted through two electro-magnets concealed within the poise. These magnets actuate corresponding trains of clock-work; so that, when the beam rises, the poise rolls out, and when it falls the poise rolls backward. The registering cylinder, carrying the sheet of cross-section paper, is operated in a similar manner by the same current; so that it is moved to and fro, in exact correspondence with the motion of the poise. A piece of steel tape is arranged to pass along the specimen, and is connected with the pencil carried on the top of the cylinder. As a result, the entire action of the stress, and corresponding strain upon the test-specimen, is recorded on the cross-section paper. The current which actuates the mechanism, and keeps the

machine in motion, flows through the piece itself, and as a consequence, the rupture of the test-piece breaks the current, and the whole apparatus comes to a standstill.

219. Tests by Impact are considered better adapted to the determination of the quality of the metal worked into rails, axles of railway rolling-stock, and in chain cables, than any other tests. The method adopted by the Chain-cable Committee of the U. S. Board was as follows :

Test-pieces 2 inches (5.08 centimetres) in diameter, and not less than twelve diameters in length, were placed across a hole through an anvil 8 inches (20.3 centimetres) in diameter, the centres being directly under the edge of a wedge-shaped hammer, which was raised to various heights and allowed to drop upon them.

Bars of some irons tested by this method could, while in their normal condition, the skin being in no manner nicked or weakened, be broken in two by blows of less than 3,000 foot-pounds force ; with other irons it is necessary to weaken them by a circular score $\frac{1}{8}$ of an inch (0.08 centimetre) deep, it not being convenient to use a hammer of over one hundred pounds' weight and one which could be raised but thirty feet. This cut through the skin reduced the resistance of the bar in the same manner that it is reduced by the ordinary method of nicking with a cold-chisel ; but with this machine the force of the blow could be regulated and known, and the weakening produced by the cuts made uniform. The wedge-shaped portion of the striking edge of the hammer permitted a bar to bend to an angle of 120° .

Through the data collected by the test, by this method of a large number of bars of various irons, differing widely in character, they were able to partially trace their characteristics, as displayed under tension, and as produced by impact. Iron with high tensile strength generally proved to be possessed of but comparatively low resilience ; it would break under the blows with but slight deflection, and leave a fractured surface, smooth as though the bar had been cut in two by a sharp knife, the ends of the fibres showing, like steel, a fine, slightly granular surface.

Irons of coarse, slightly worked character have a smooth

and bright surface, but the coarse, granular appearance of the cut fibres showed how slightly they had been affected by the rolls.

Iron with a high elastic limit resisted the first blow with but little injury or deflection; but, the deflection once started by subsequent blows, it then yielded more at each than did other irons with a lower limit, which latter were more affected by the first blow. Some irons, after having been weakened by the circular cut through the skin, resist, with slight injury, blows which would break bars of the same size of other irons which had not been so weakened.

There are many irons valuable for many purposes, which do not yield good results under this form of test; but, however valuable for other purposes, the material which proves brittle under test cannot be expected when made into cable, and subjected to strains of a similar nature, to prove equal to its work.

Iron which is materially weakened by a repetition of slight sudden strains, none of which produce perceptible injury, but which do so injure it that eventually a strain no greater, and perhaps much less, than those previously encountered, will destroy it, is not suitable for cable. Iron of which the strength depends upon its remaining perfectly free from abrasion or slight cracks, is not suitable for cables.

220. Transverse Testing-Machines.—*For testing transverse resistance*, the Author has been accustomed, when loads not exceeding about 5 tons (5,080 kilogrammes) were to be carried, to use a machine designed for this special purpose. It is illustrated in Fig. 68.

It consists of a platform scale, on the platform of which rests a heavy cast-iron beam, *C*, to which are fastened the supports, *DD*, at the required distances apart. The pressure is applied by means of the hand-wheel on the upper end of the screw, *K*, which screw passes through the nut, *E*, and terminates in the sliding cross-head, *I*. This cross-head serves both as a guide and as a pressure-block. The test-piece, *L*, rests upon mandrels mounted upon the supports, *DD*, at the

required distance apart. The loads are weighed in the usual manner at *M*.

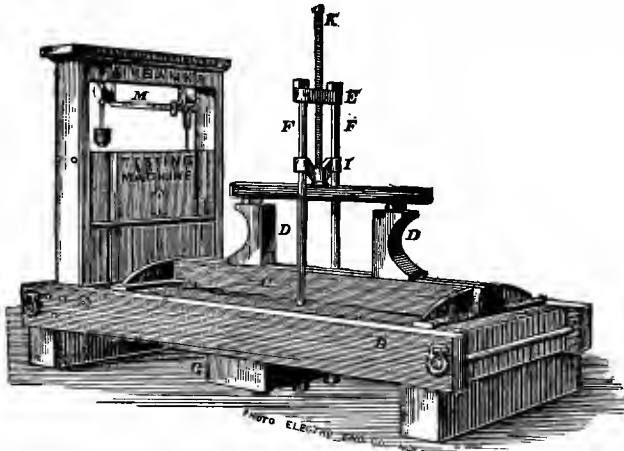

FIG. 68.—FAIRBANKS' TRANSVERSE TESTING-MACHINE.

The instrument for measuring deflections is not shown in the cut; it consists of an accurately cut micrometer screw of steel, having a pitch of 0.025 inch (0.063 centimetre), working in a nut of the same material mounted in a brass frame. This instrument is supported by a rod of considerable rigidity and of sufficient length, which is secured to the beam, *C*, close to the tension rods, *FF*, and in such a manner that the micrometer is directly over the cross-head, in the same vertical plane with the test-piece, and very near and parallel with the axis of the large screw, *K*. The micrometer screw is provided with a head which is divided into 250 equal parts. Thus, a rotary motion of one division produces an advance in the direction of the axis of the micrometer screw of 0.0001 inch (0.00025 centimetre). A scale divided into fortieths of an inch is fastened to the frame of the instrument, in close proximity to the head and parallel to the axis of the screw; it serves to mark the starting point and indicates the number of revolutions made in taking a measurement with the screw.

To insure accurate readings of the deflections, the method above described of determining measurements by electric

contact is also employed here. Where tests are to be made in which heavier loads are to be carried, an attachment to the machine commonly used for tests by tension is fitted in its place, and the tests are then made on that machine.

In some cases, as where large girders or structures of considerable magnitude are to be tested, loads must be directly applied.

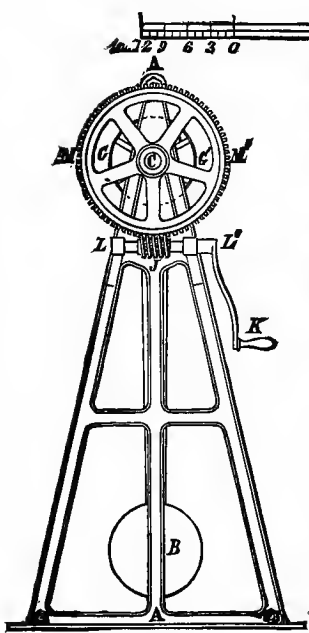

Fig. 69.

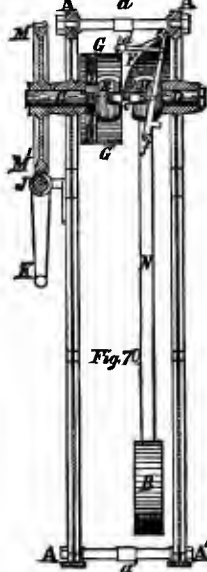
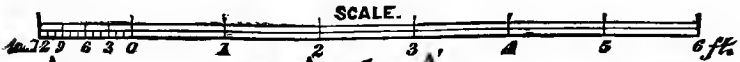

Fig. 70.

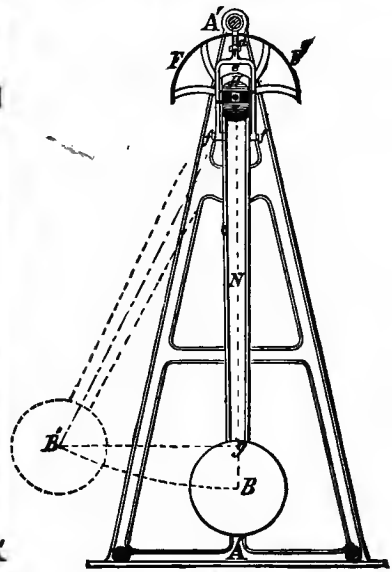

Fig. 71.

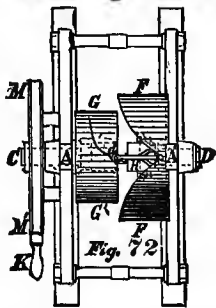

Fig. 72.

221. The "Autographic" Testing-Machine devised by the Author is used where it is desired to obtain a knowledge of the general character of the metal, including its elasticity and resilience, and the method of variation of its normal series of elastic limits, and where a permanent graphical record is found useful. It is shown in the accompanying figures.

Fig. 74 is a perspective view of this machine; Fig. 69 is a front elevation; Fig. 70, a longitudinal section on line AA of Fig. 69; Fig. 71, a transverse section on $a a'$ of Fig. 70, and Fig. 72 is a plan with the top cross-bolt a removed. It consists of two A-shaped frames, AA and $A'A'$, shown in all the figures. These are firmly mounted on a heavy bed-plate, which is shown in Fig. 74. The frames are secured to each other by cross-bolts, a and a' . Near the top of each of these frames are spindles, C and D , Figs. 69, 70, and 71, each of which has a head, E and H , with a slot or jaw to receive and hold the square heads of the specimens. The two spindles are not connected to each other in any way, excepting by the specimen which is placed in the jaws to be tested, as shown at c in Figs. 70 and 71. To the spindle D a long arm, HB , is attached, which carries a heavy weight, B , at the lower end. The spindle C has a worm-gear wheel, MM' , attached to its outer end. This wheel is driven by a worm, \mathcal{F} , on the shaft LL' , which is turned by a hand crank, K . When a specimen, c , is placed in the two jaws, E, H , as shown in Fig. 70, and the spindle C is turned by the worm gear, the effect is to twist the specimen c , which would turn the spindle, D ; but in order to do this the weight, B , Figs. 70 and 71, on the end of the arm, N , must be swung in the direction in which the specimen is twisted. But the farther the arm, N , is moved from a vertical position, the greater will be the resistance of the weight, B , to the turning of the shaft, while the movement of the arm and weight is effected by the force exerted through the specimen, c , so that the position of the arm and weight will at all times give a measure of the torsional stress, which is exerted on the specimen, Fig. 73, by the spindle C , and transmitted by the former to the spindle D .

But as this torsional stress which is exerted on the specimen is increased, it will at once commence to "give way," or be twisted

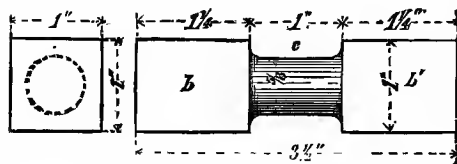

FIG. 73.—TEST-PIECE.

more or less by the stress according to the quality of the material. In making such torsional tests, it is essential that we should

know how much the specimen was twisted, as the strains to which it was subjected were increased. If we could procure a record of this, it would be an indication of the capacity of the material to resist such stresses, or, in other words, of its quality. The testing-machine, which has been described, was designed by the Author for this purpose. The record is made in the following way: To the spindle *C*, a cylindrical drum, *G G'*, Figs. 70, 71, and 72, is attached, which is covered with a suitable sheet of paper. Fig. 72 is a plan of the top of the machine, which shows the drum, *G G'*. To the arm, *N*, a pencil-holder, *d e f*, Figs. 70 and 71, is pivoted at *f f*, and carries a pencil, *d*, the point of which bears on the paper on the drum, *G G'*. Now supposing that the specimen in the machine should offer no resistance, but should merely twist, the pencil would then remain stationary, and as the drum is revolved the pencil would trace a straight line on the paper, the length of which line would measure the amount by which the specimen was twisted. If, on the other hand, a specimen be supposed to resist and to twist simultaneously, as is always the case, then it will presently be seen that the spindle, *D*, would be turned, and the arm, *N*, with its weight would be moved from a vertical position a distance proportional to the strain resisted by the specimen. The pencil-holder, being attached to the arm, *N*, would move with it. As explained before, the distance which the arm, *N*, and its weight are moved from a vertical position indicates the stress on the specimen. Next, in order to make a record of this distance, a "guide-curve," *F F'*, shown most clearly in Fig.

72, is attached to the frame of the machine, so that when the arm, *N*, and the pencil-holder are moved out of their vertical position, shown in Figs. 70 and 72, the pencil is



FIG. 74.—AUTOGRAPHIC MACHINE.

moved toward the left by the guide-curve, which is of such a form that the lateral movement which it gives to the pencil is proportional to the moment of the weight, B , on the end of the arm, N . Now suppose, if such a thing were possible, that a specimen were tested which would not "give" or twist at all; in that case, the spindles, C and D , and the drum, $G G'$, and the pencil would turn together, or their movements would be simultaneous, so that the pencil would draw a straight line along the paper. But there is no material known which would not yield or twist more or less, so that the pencil will always draw some form of curved line, somewhat like that shown by $G d$, Fig. 72, which indicates the quality of the material tested.

Before describing the nature of these curves, it should be explained that the test-pieces are held in a central position in the jaws by lathe "centres," which are placed in suitable holes drilled in the spindles for that purpose. The centre in the head, H , is fixed, whereas the one in E is movable, and has a helical spring behind it which presses it outward, and thus holds the specimen up to the centre in the head, H . The specimen is then held securely by wedges, which are shown by black shading in Figs. 70 and 71, above and below the specimen c .

In these machines, each inch of ordinate denotes 100 foot-pounds of moment transmitted through the test-piece, and each inch of abscissa indicates 10 degrees of torsion. The friction of the machine is not recorded, but is determined when the machine is standardized, and is added in calculating the results.

By the use of this machine, the metal tested is compelled to tell its own story, and to give a permanent record and graphical representation of its strength, elasticity and every other quality which is brought into play during its test, and thus to exhibit all its characteristic peculiarities.

The strain-diagram produced in this manner is usually similar in general form to those which are illustrated elsewhere in this chapter, and a few of which will be presented in fac simile.

TABLE XLV.

MAXIMUM EXTENSIONS; TEST-PIECES 1 INCH (2.54 CENTIMETRES) LONG,
 $\frac{5}{8}$ INCH (1.6 CENTIMETRES) DIAMETER.

If A = total angle of torsion, then the extension of an exterior fibre is

$$e = \sqrt{I + A^2 \times 0.0002974775} - I$$

ANGLE OF TORSION.	EXTENSION.	EQUIVALENT REDUCED SECTION.	ANGLE OF TORSION.	EXTENSION.	EQUIVALENT REDUCED SECTION.	ANGLE OF TORSION.	EXTENSION.	EQUIVALENT REDUCED SECTION.
Deg.			Deg.			Deg.		
1	0.000,015	1.000	46	0.030,993	0.969	225	0.583,029	0.632
2	0.000,060	1.000	48	0.033,702	0.967	230	0.604,262	0.623
3	0.000,134	1.000	50	0.036,518	0.965	235	0.625,675	0.615
4	0.000,238	1.000	55	0.044,025	0.957	240	0.647,261	0.607
5	0.000,372	1.000	60	0.052,184	0.950	245	0.669,014	0.592
6	0.000,535	1.000	65	0.060,983	0.942	250	0.690,927	0.594
7	0.000,729	0.999	70	0.070,404	0.934	255	0.712,994	0.584
8	0.000,951	0.999	75	0.080,431	0.925	260	0.735,208	0.576
9	0.001,204	0.999	80	0.091,048	0.917	265	0.757,565	0.568
10	0.001,486	0.999	85	0.102,232	0.907	270	0.780,059	0.562
11	0.001,798	0.998	90	0.113,980	0.898	275	0.802,685	0.555
12	0.002,140	0.998	95	0.126,265	0.889	280	0.825,438	0.548
13	0.002,511	0.998	100	0.139,069	0.879	285	0.848,313	0.531
14	0.002,911	0.997	105	0.152,375	0.868	290	0.871,306	0.534
15	0.003,341	0.997	110	0.166,168	0.858	295	0.894,412	0.528
16	0.003,800	0.996	115	0.180,430	0.847	300	0.917,628	0.522
17	0.004,289	0.996	120	0.195,143	0.837	305	0.940,944	0.515
18	0.004,807	0.996	125	0.210,293	0.826	310	0.964,372	0.509
19	0.005,355	0.995	130	0.225,862	0.816	315	0.987,893	0.503
20	0.005,932	0.994	135	0.241,834	0.805	320	1.011,509	0.497
21	0.006,538	0.994	140	0.258,195	0.795	325	1.035,216	0.492
22	0.007,173	0.993	145	0.274,930	0.784	330	1.059,012	0.486
23	0.007,838	0.993	150	0.292,023	0.774	335	1.082,893	0.480
24	0.008,531	0.992	155	0.309,462	0.764	340	1.106,855	0.475
25	0.009,253	0.991	160	0.327,231	0.754	345	1.130,898	0.469
26	0.010,005	0.990	165	0.345,319	0.743	350	1.155,017	0.464
27	0.010,785	0.989	170	0.363,712	0.734	355	1.179,211	0.459
28	0.011,594	0.989	175	0.382,398	0.723	360	1.203,476	0.454
29	0.012,432	0.998	180	0.401,366	0.714	370	1.252,214	0.444
30	0.013,298	0.987	185	0.420,604	0.704	380	1.301,217	0.434
32	0.015,117	0.985	190	0.440,102	0.694	390	1.350,454	0.425
34	0.017,049	0.983	195	0.459,849	0.685	400	1.399,925	0.417
36	0.019,094	0.981	200	0.479,834	0.676	420	1.490,501	0.400
38	0.021,252	0.979	205	0.500,050	0.667	460	1.700,856	0.370
40	0.023,522	0.977	210	0.520,485	0.658	500	1.904,641	0.344
42	0.025,902	0.975	215	0.541,133	0.649	540	2.110,377	0.321
44	0.028,393	0.972	220	0.561,983	0.641	600	2.421,869	0.292

Its ordinates measure stresses in foot-pounds of torsional

moment on a scale of 100-foot pounds to the inch (5.52 kilogrammetres per vertical centimetre). The abscissas measure degrees of angular distortion on a scale of 10 per inch (4 per centimetre), and a printed table of extensions is used to obtain the corresponding value of the extension of a line of fibre on the surface of the distorted parts of test-piece which is initially parallel to the axis. The same quantity can be obtained by the use of the formula

$$e = \sqrt{(1 + 0.00002974775A^2)} - 1 \quad . . . \quad (16)$$

in which A is the total angle of torsion, and where the standard dimensions of test-piece are taken, *i.e.* diameter, $\frac{5}{8}$ inch (1.59 centimetre); length, 1 inch (2.54 centimetres).

The preceding table exhibits the measurements of extension as deduced from the strain-diagram produced by this machine. The figures given represent the per cent. of extension of an exterior line of particles, or a fibre, originally parallel with the axis, but, after fracture, forming a helix of increased linear dimension. The maximum extension given in Table XLV., as corresponding to the angle indicated on the strain-diagram at the elastic limit, is the extension, as a fraction of the total length, at the *proof-strain*. The extension corresponding to the angle at which the maximum resistance is attained is taken to be the maximum ductility under direct *tension*, as indicated by reduction of section. The extension given in the table at the angle shown by the strain-diagram to be the maximum angle before the commencement of rupture is a measure of the maximum ductility under *torsion*.

222. The Variation of Form of Test-Piece so considerably modifies the apparent tenacity of iron and steel that it is necessary to note the size and shape of the specimen tested before an intelligent understanding of the value of the material can be arrived at by examination of data secured by test. When a piece of metal is subjected to stress and slowly pulled asunder, it will yield at the weakest section first, and if that section is of considerably less area than adjacent parts,

Fig. 75, or if the metal is not ductile, it will often break sharply, and without stretching appreciably, as seen in Fig. 77; the fractured surface will have a granular appearance, and the behavior of the piece, as a whole, may be like that of a brittle casting, even although actually made of tough and ductile metal, when the piece is deeply scored

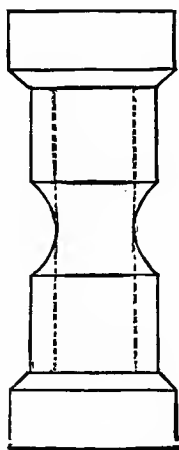

FIG. 75.—Incorrect.

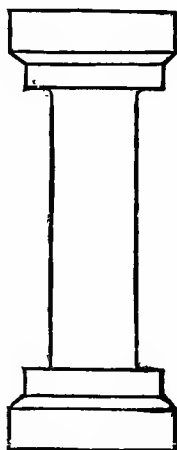

FIG. 76.—Correct.

FORMS OF TEST PIECES FOR TENSION.

When a bar of very ductile metal, of perfectly uniform cross-section, Fig. 76, is broken, on the other hand, it will, at first, if of uniform quality, gradually stretch with a nearly uniform reduction of section from end to end. Toward the ends, where held by the machine, this reduction of area is less perceivable, and on the extreme ends where no strain can occur, except from the compressing action of the grips, the original area of section is retained, diminution taking place from that point to the most strained part by a gradual taper or by a sudden reduction of section, according to the method adopted of holding the rod. When the stress has attained so great an intensity that the weakest section is strained beyond its elastic limit, "flow" begins there, and,

while the extension of other parts continues slowly, the portions immediately adjacent to the overstrained section stretch more and more rapidly as this local reduction of section continues, and finally fracture takes place. This locally reduced portion of the rod has a length which is dependent upon the character of the metal and the size of the piece.



FIG. 77.

Hard and brittle materials exhibit very little reduction and the reduced portion is short, as in Fig. 77; ductile and tough metals exhibit a marked reduction over a length of several diameters, and great reduction at the fractured section, as seen in Fig. 78. Of the samples shown in the figures, the first is of a good, but a badly worked, iron, and the second from the same metal after it had been more thoroughly worked.

When the breaking section is determined by deeply grooving the test-piece, the results of test are higher by 5 or 10 per cent. than when the cylinders are not so cut, if the metal is hard and brittle, and by 20 to 25 per cent. with tough and ductile irons or steels. In ordinary work this difference will average at least 20 per cent. with the ductile metals. A good bridge or cable iron in pieces of 1 inch (2.54 centimetres) diameter cut from 2-inch (5.08 centimetres) bar, exhibited a tenacity of 50,000 pounds per square inch in long test-pieces, and 60,000 in short grooved specimens (3,515 to 4,218 kilogrammes per square centimetre). Cast irons will give practically equal results by both tests, as will hard steels and very coarse-grained hard wrought irons.

Since these differences are so great that it is necessary to ascertain the form of samples tested before the results of test can be properly interpreted, it becomes advisable to use a test-piece of standard shape and size for all tests the results of which are to be compared. The figures given hereafter, when not otherwise stated, may be assumed to apply to pieces

of one half square inch area (3.23 square centimetres) of section, and at least 5 diameters in length. This length is usually quite sufficient, and is taken by the Author as a minimum. For other lengths, the extension is measured by a constant function of the total length plus a function of the diameter, which varies with the quality of the metal and the shape of the test-piece. It may be expressed by the formula

$$e = al + f(d) \dots \dots (17)$$

The elongation often increases from 20 up to 40 per cent., as the test-piece is shortened from 5 inches (12.7 centimetres) to $\frac{1}{2}$ inch (1.27 centimetres) in length, while the contraction of section is, on the other hand, decreased from 50 down to 25 per cent., nearly. Fairbairn,* testing good round bar-iron, found that the extension for lengths varying from 10 inches (25.4 centimetres) to 10 feet (3.28 metres) could be expressed, for such iron, by the formula

$$e = 18 + \frac{25}{l} \dots \dots (18)$$



FIG. 78.

where l is the length of bar in inches. In metric measures this becomes

$$e = 18 + \frac{63.5}{l};$$

l = length in centimetres; e = elongation per unit of length.

This influence of form is as important in testing soft steels as in working on iron. Col. Wilmot, testing Bessemer "steel" at the Woolwich Arsenal, G. B., obtained the following figures :

* *Useful Information*, Second series, p. 301.

Form.	Test-piece.	TENACITY:	
		Lbs. per sq. in. ;	kilogs per sq. cm
Grooved, Fig. 75,	Highest.....	162,974	11,457
	Lowest	136,490	9,595
	Average.....	153,677	10,803
Long cylinder.....	Highest.....	123,165	8,658
	Lowest	103,255	7,259
	Average.....	114,460	8,047

The difference amounts to between 30 and 35 per cent., the groove giving an abnormally high figure.

It is evident from the above that the elongation must be proportionably much greater in short specimens than in long pieces. This is well shown in Table XLVI. of tests made by Beardslee, for the United States Board.*

TABLE XLVI.

TESTS OF TEST-PIECES OF VARYING PROPORTIONS—TENSION.

NUMBER.	LENGTH.		PER CENT. OF ELONGATION.		DIAMETER.		PER CENT. OF CONTRACTION OF AREA		STRESS WHEN PIECE BEGAN TO STRETCH OBSERVABLY.		BREAKING-STRESS.		REMARKS.
	Original.	Final.	Original.	Reduced.	Original.	Reduced.	Observed stress.	Stress per square inch.	Observed stress.	Stress per square inch.			
	In.	In.	In.	In.	Lbs.	Lbs.	Lbs.	Lbs.					
1	5.000	6.522	30.0	.708	568	49.3	13,400	26,800	26,000	51,989	Elastic limit, 26,795 lbs. per sq. in.		
2	3.938	5.204	32.0	.708	.564	50.0	14,000	28,000	26,200	52,389	Elastic limit, 28,194 lbs. per sq. in.		
3	4.500	5.853	30.0	.707	.584	46.3	14,000	28,200	26,190	52,495	Elastic limit, 28,062 lbs. per sq. in.		
4	3.500	4.635	31.6	.701	.570	48.0	13,000	26,450	26,070	53,052	Elastic limit, 27,268 lbs. per sq. in.		
5	3.000	3.977	33.0	.702	.571	48.0	14,000	28,420	26,100	52,984			
6	2.472	3.266	32.1	.709	.589	45.6	14,000	27,920	26,500	52,852			
7	1.989	2.644	32.0	.708	.591	45.0	14,000	28,000	26,500	53,169			
8	1.500	2.026	35.0	.707	.590	45.2	15,500	31,320	26,275	52,666			
9	1.000	1.354	35.4	.708	.600	43.5	16,675	33,350	26,590	53,169			
10	0.500	0.708	41.6	.708	.635	36.6	18,760	37,520	28,665	57,318			

With such brittle materials as the cast irons, the difference becomes unimportant. Beardslee found a difference of but 1 per cent. in certain cases. The more brittle the material the less this variation of the observed tenacity.

As will be seen later, even more important variations follow changes of proportion of pieces in compression. No test-piece should be of very small diameter, as inaccuracy is

* Report, p. 104.

[To face page 389.]

TABLE XLVIA.

EFFECTS OF VARIATION IN FORM OF TEST PIECE.

Form of Specimens Nos. 5783 to 5791.

Form of Specimens Nos. 5867 to 5869.

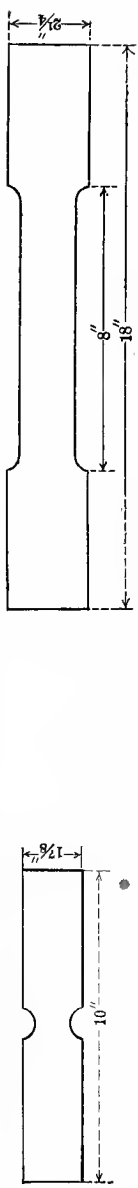

No. of Test.	Dimensions.		Sectional Area.	Elastic Limit.		Tensile Strength.		Elongation in 8 Inches.		Area at Fracture.	Contraction of Area.	Appearance of Fracture.	Elongation of Inch Sections.
	Width.	Thickness.		Total.	Per Square Inch.	Total.	Per Square Inch.	Ins.	Per Cent.				
5783	1.00	.424	Sq. in. .424	Pounds	Per Square Inch.	Pounds 24,970	Per Square Inch. 58,890	Ins.	Per Cent.	Inches. Sq. In. .83 X .24 = .199	% 53.1	Silky	Inches.
5784	1.00	.434	.434	25,290	58,27082 X .23 = .189	56.5	"	"
5785	1.00	.447	.447	25,310	57,74082 X .23 = .189	57.7	"	"
5786	1.00	.411	.411	24,650	59,97085 X .22 = .187	54.5	"	"
5787	1.00	.429	.429	24,160	56,32078 X .23 = .179	58.3	"	"
5788	1.00	.440	.440	24,995	56,81079 X .23 = .182	58.6	"	"
5789	1.00	.438	.438	25,280	57,72083 X .22 = .183	58.2	"	"
5790	1.00	.426	.426	24,880	58,40083 X .22 = .183	57.1	"	"
5791	1.00	.422	.422	24,470	57,99083 X .22 = .183	56.6	"	"
5867 Dome	1.496	.370	.553	20,250	36,620	29,170	52,750	2.08	26.0	1.08 X .21 = .227	58.9	"	.12, .19, .24, .72, .28, .23, .18, .12,
5868 Dome	1.495	.377	.564	21,100	37,410	32,050	56,830	2.09	26.1	1.11 X .23 = .255	54.8	"	.12, .25, .22, .27, .65, .27, .26, .11,
5869 Dome	1.497	.370	.554	19,980	36,060	29,060	52,450	1.99	24.9	1.10 X .20 = .220	60.3	Silky, slightly lamellar	.13, .66, .36, .22, .19, .19, 20, .10

more probable with a small than with a large piece, and the errors are more likely to be increased in reduction to the stress per square inch. The length should not be less than four times the diameter in any case, and with soft, ductile metal, five or six diameters would be preferable for tension.

Where much work is to be done, it is quite important that a set of standard shapes of test pieces should be selected, and that all the tests should be made upon samples worked to standard size and form. Thus, tension-pieces are often made of the shapes seen in the figure, when testing square, cylindrical, or flat samples, or samples cut from the solid. The last is a shape called for under the U. S. inspection laws when testing boiler-plate; but it should never be used, if choice is permitted, as it gives no chance of stretching, and is therefore nearly useless as a gauge of the quality of the metal; it will undoubtedly be abandoned in course of time, as it invariably gives too high a figure, and does not distinguish the hard and brittle from the better and tougher materials which are desired in construction.

The dimensions adopted by the Author are one-half square inch (3.23 square centimetres) section for all metals except the tool steels (0.798 inch; 2 centimetres diameter, when round), and one-eighth or one-quarter square inch (0.81 to 1.61 square centimetres area; 0.398 or 0.565 inch or 1.4 centimetres diameter) for the latter, at the smallest cross-section. Kent, who sketches the above, takes these shapes, making them, if of tool steel, $\frac{11}{16}$ inch diameter (1.75 centimetre), or $\frac{3}{8}$ square inch (2.44 square centimetres) area;

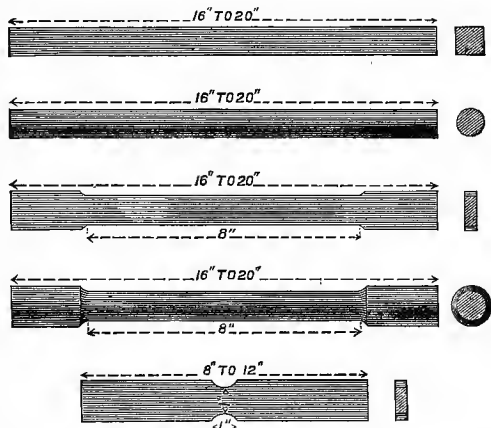

FIG. 79.—SHAPES FOR TEST PIECES.

in other metals either $\frac{3}{4}$ -inch (1.9 centimetres) diameter or 0.44 square inch (2.84 square centimetres), or as above. The edges should be true and smooth, and the fillets $\frac{1}{2}$ -inch radius.

For compression tests of metal, 1 inch (2.54 centimetres) long and $\frac{1}{2}$ -inch (1.27 centimetres) diameter, ends perfectly square, is recommended. For stone and brick, a 2-inch (5.08 centimetres) cube. Transverse test-pieces should not be less than 1 foot, nor more than 4 feet in length, when to be handled in ordinary machines.

The standard specimen will be taken as above, and good wrought iron of such shape and size should exhibit a tenacity of at least 50,000 pounds (3,515 kilogrammes per square centimetre) if from bars not exceeding 2 inches (5.08 centimetres) diameter, and should stretch 25 per cent. with 40 per cent. reduction of area. Such test-pieces have the advantage of giving uniform comparable and minimum figures for tenacity, and of permitting accurate determinations of elongation.

Test-pieces are only satisfactory in form when turned in the lathe, as the coincidence of the central line of figure with the line of pull is thus most perfectly insured. When, as with sheet metal, this cannot be done readily, care must be taken to secure proportions of length and cross-section as nearly alike those of the standard test-piece as possible, and to secure symmetry and exactness of form and dimension; such pieces are liable to yield by tearing when not well made and properly adjusted in the machine.

223. The Method of Use of Testing Machines is, in general, the same for all cases, and is only modified by methods of holding the piece and of taking measurements which may be peculiar to the machine used.

The piece being carefully adjusted in the clamps, and the measuring apparatus so attached that its indications may be relied upon, and that it is not likely to be injured by any accident during the test, the load is very slowly and steadily applied. At intervals, readings of elongation and of load are taken and recorded, and the observer, noting their rate of increase, after a time detects a change in their ratio which indicates that the elastic limit is reached, and that extension is

taking place more rapidly with each accession of load. The fracture of the piece can usually be anticipated, and the measuring apparatus is removed before danger is incurred of its injury by the shock of breaking. With brittle materials the final break takes place suddenly, and without warning. The observer must therefore depend upon his knowledge that such material is likely to break at not far from a known load. Ductile substances usually pass a limit of maximum load, and break after stretching an appreciable amount with gradually diminishing resistance.

When "sets" are to be measured, all load is removed at intervals during the test, and the piece is permitted to recoil. The difference between its length now unloaded and the original length, is the "set." This set is usually partly temporary, and the piece, if left unloaded, will often very slowly contract for a considerable time, thus perceptibly reducing the set, which then becomes permanent. It is not advisable to take measurements of set unless for a special purpose, as each relaxation of the piece modifies its resisting power, and makes comparison with other samples less easy and satisfactory.

When broken, the pieces are removed from the machine, their final length is measured, and they are carefully examined to obtain such knowledge of the quality of the metal as may be secured by a study of their texture and of the character of their fracture.

224. The Method of Record is a matter of some importance in making researches relating to the strength of materials. The Author has been accustomed to use printed blanks for such work. The following are the headings adopted.

Of these blanks, the first is used indifferently for either tension or compression, and the last for miscellaneous purposes.

An examination of the records to be given in the following pages will show that the customs of the various departments, as well as of individual investigators, differ greatly, not only in the extent to which the minuteness of measurement is carried, but also in their methods of securing results and recording them. The columns in the blanks here given are not always all filled out.

225. Records of Tests.—The following are figures derived from such a test by tension, as made for the Author:

TABLE XLVII.

TEST OF WROUGHT IRON, LENGTH 8" (19.32 CM.); DIAM., 0.798" (2.03 CM.).

LOADS.		MICROMETER READINGS.		EXTENSIONS.		SETS.	
Actual.	Per sq. inch.			Actual.	Per Cent.	Actual.	Per Cent.
1506600	.7913
2,000	4,000	.6628	.7910	.0013	.016
4,000	8,000	.6637	.7922	.0023	.029
6,000	12,000	.6646	.7930	.0035	.044
8,000	16,000	.6606	.7946	.0050	.063
10,000	12,000	.6630	.7948	.0058	.073
1506600	.79140001	.001
11,000	22,000	.6639	.7951	.0064	.030
12,000	24,000	.6700	.7953	.0070	.037
1506603	.79150003	.004
13,000	26,000	.6715	.7967	.0080	.100
13,500	27,000	.6728	.7959	.0087	.109
14,000	28,000	.7242	.8424	.0577	.721
1507133	.83510486	.608
15,000	30,000	.7535	.8712	.0867	1.084
1507417	.86320763	.960
17,000	34,000	.8474	.9618	.1790	2.238
1508326	.95181666	2.083
19,000	38,000	.9720	1.0856	.3032	3.790
1509562	1.07322391	3.613
21,000	42,000	1.1710	1.2811	.5004	6.255
150	1.1524	1.26634337	6.043
22,000	44,000	1.3303	1.4381	.6586	8.233
150	1.3102	1.42126401	8.001
22,500	45,000	1.4575	1.5441	.7752	9.690
23,000	46,000	1.5610	1.6670	.8884	11.105
23,500	47,000	1.7646	1.8693	1.0913	13.841
23,750	47,500		9.47	1.4700	18.375
21,800	43,600		9.54	1.5400	19.250

Actual.	ELASTIC LIMIT.				Ultimate Elongation, per cent. of length = 19½. Reduction of Area, per cent., = 31.99. Modulus of Elasticity = 24,365,000 lbs. on sq. in. Modulus of Elasticity = 1,712,860 kilogrammes on sq. cm.
Lbs.	Kgs.	Lbs. per sq. in.	Kgs. per sq. cm.		
13,500	6140	27,000	1,898		
BREAKING LOAD.					
Original Sect.		Fractured Sect.		FINAL DIMENSIONS. Length = 9".54 Diameter = 0".658	
Lbs. per sq. in.	Kgs. per sq. cm.	Lbs. per sq. in.	Kgs. per sq. cm.		
47,500	3,340	69,840	4,910		

The following is the record of a test of wrought iron made by the Ordnance Department, U. S. N.

TABLE XLVIII.
RECORD OF TEST OF WROUGHT IRON.

WEIGHT PER SQUARE INCH OF SECTION.	EXTENSION.	FIRST DIFFERENCE.	RESTORATION.	FIRST DIFFERENCE.	PERMANENT SET.	FIRST DIFFERENCE.
Lbs.						
1,500	0.00000	0.00000	0.00000	0.00000	0.00000	0.00000
3,000	0.00000	0.00000	0.00000	0.00000	0.00000	0.00000
4,500	0.00000	0.00000	0.00000	0.00000	0.00000	0.00000
6,000	0.00000	0.00000	0.00000	0.00000	0.00000	0.00000
7,500	0.00000	0.00000	0.00000	0.00000	0.00000	0.00000
9,000	0.00000	0.00000	0.00000	0.00000	0.00000	0.00000
10,500	0.00000	0.00000	0.00000	0.00000	0.00000	0.00000
12,000	0.00000	0.00000	0.00000	0.00000	0.00000	0.00000
13,500	0.00000	0.00000	0.00000	0.00000	0.00000	0.00000
15,000	0.00000	0.00000	0.00000	0.00000	0.00000	0.00000
16,500	0.00100	0.00000	0.00100	0.00000	0.00000	0.00000
18,000	0.00150	0.00050	0.00150	0.00050	0.00000	0.00000
19,500	0.00200	0.00050	0.00200	0.00050	0.00000	0.00000
21,000	0.00225	0.00025	0.00225	0.00025	0.00000	0.00000
22,500	0.00250	0.00025	0.00150	—0.00075	0.00100	0.00100
24,000	0.00275	0.00025	0.00125	—0.00025	0.00150	0.00050
25,500	0.00300	0.00025	0.00100	—0.00025	0.00200	0.00050
27,000	0.00350	0.00050	0.00125	0.00025	0.00225	0.00025
28,500	0.00500	0.00150	0.00200	0.00075	0.00300	0.00075
30,000	0.00550	0.00050	0.00125	—0.00075	0.00425	0.00125
31,500	0.00750	0.00200	0.00200	0.00075	0.00550	0.00125
33,000	0.00950	0.00200	0.00100	0.00100	0.00850	0.00300
34,500	0.01550	0.00600	0.00100	0.00000	0.01450	0.00600
36,000	0.02000	0.00450	0.00200	0.00100	0.01800	0.00350
37,500	0.02500	0.00500	0.00100	—0.00100	0.02400	0.00600
39,000	0.02800	0.00300	0.00150	0.00050	0.02650	0.00250
40,500	0.03400	0.00600	0.00250	0.00100	0.03150	0.00500
42,000	0.04000	0.00600	0.00275	0.00025	0.03725	0.00575
43,500	0.06150	0.02150	0.00750	0.00475	0.05400	0.01675
45,000	0.06450	0.00300	0.00800	0.00050	0.05650	0.00250
46,500	0.06650	0.00200	0.00350	—0.00450	0.06300	0.00650
48,000	0.06900	0.00250	0.00250	—0.00100	0.06650	0.00350
49,500	0.08650	0.01750	0.00200	0.00050	0.08450	0.01800
51,000	0.10200	0.01550	0.00200	0.00000	0.10000	0.01550
52,500	0.12550	0.02250	0.00300	0.00100	0.12250	0.02250
53,000	0.31100	0.18550	Specimen broke.			

Specific gravity..... 7.6810 | Character of rupture... Fine, fibrous.
Original diameter..... 0".650 | Total elongation..... 0".311
Diameter at point of rupture.. 0".453

This sample was 2 inches (5.08 centimetres) in length between shoulders, and 0.65 inch (1.65 centimetres) in diameter. It had a tenacity of 53,070 pounds per square inch (3,732 kilogrammes per square centimetre), and was considered good iron. A length of 5 or 8 inches would have been better.

The following table represents the results in metric measures, as reduced by Morin, of one of Hodgkinson's most complete tests of a bar of good wrought iron :

TABLE XLIX.
TEST OF WROUGHT IRON (BAR).

WEIGHT IN KILOGRAMMES PER SQUARE CENTI- METRE. <i>P.</i>	ELONGATION PER METRE OF LENGTH.		COEFFICIENT OF ELASTICITY PER SQUARE METRE. <i>E.</i>
	Total <i>e.</i>	Permanent.	
Kilogrammes.	Metres.	Millimetres.	Kilogrammes.
187.429	0.000082117	22,824,500,000
374.930	0.000185261	20,216,200,000
562.406	0.000283704	0.00254	19,824,100,000
749.456	0.000379467	0.0033894	19,704,000,000
937.430	0.000475113	0.0042398	19,729,909,000
1124.813	0.000570792	0.00508	19,706,000,000
1312.283	0.000665647	9.0067705	19,714,600,000
1499.720	0.000760311	0.0100879	19,320,300,000
1687.219	0.0008573265	0.0330283	19,320,700,000
1874.645	0.001012911	0.0829955	18,398,100,000
2063.580	0.001283361	0.2616950	16,079,200,000
2249.627	0.002227205
2403.653	0.004287185	3.0709900	5,606,590,000
2624.564	0.009156490	8.4690700	2,866,380,000
.....	0.009950970	8.5748700
2812.033	0.010492805	9.1023600	2,681,520,000
Repeated after 1 hour.	0.011750313
" " 2 "	0.011858889
" " 3 "	0.011933837
" " 4 "	0.011942168
" " 5 "	0.011958835
" " 6 "	0.011967140
" " 7 "	0.012027114
" " 8 "	0.012027014
" " 9 "	0.012027114
" " 10 "	0.012027114
2999.500	0.017888263	16.5145	1,676,820,000
2999.500	0.019478898
.....	0.01984831	18.4212
.....	0.02022006	18.8886
3186.973	0.02148590	19.7954	1,483,290,000
.....	0.02169401
.....	0.02170242
.....	0.02170242	22.0119
3374.440	0.02477441	22.7087	1,362,020,000
.....	0.02514184
.....	0.02522512
3561.900	0.03493542	32.8201	1,019,580,000
.....	0.03519357
.....	0.03520190
3745.361

The next two examples* are good illustrations of the completeness with which the careful engineer conducts such tests when the results are specially important :

* Report of U. S. Bureau of Ordnance, War Dept., 1881.

TABLE L.

EXTENSION, RESTORATION AND PERMANENT SET OF A SOLID CYLINDER OF STEEL, 3 INCHES LONG (BETWEEN SHOULDER) AND 0.622 INCH DIAMETER, TAKEN FROM BRECH-RECEIVER FOR 11-INCH BRECH-LOADING RIFLE.

WRIGHT PER SQUARE INCH OF SECTION.	EXTENSION PER INCH IN LENGTH.	SUCCESSIVE EXTENSION PER INCH IN LENGTH.	RESTORATION PER INCH IN LENGTH.	SUCCESSIVE RESTORATION PER INCH IN LENGTH.	PERMANENT SET PER INCH IN LENGTH.	SUCCESSIVE PERMANENT SET PER INCH IN LENGTH.
<i>Pounds.</i>	<i>Inches.</i>	<i>Inches.</i>	<i>Inches.</i>	<i>Inches.</i>	<i>Inches.</i>	<i>Inches.</i>
1,000	0.00000	0.00000	0.00000	0.00000	0.00000	0.00000
2,000	.00000	.00000	.00000	.00000	.00000	.00000
3,000	.00000	.00000	.00000	.00000	.00000	.00000
4,000	.00033	.00033	.00033	.00033	.00000	.00000
5,000	.00033	.00033	.00033	.00033	.00000	.00000
6,000	.00033	.00000	.00033	.00000	.00000	.00000
7,000	.00033	.00000	.00033	.00000	.00000	.00000
8,000	.00033	.00000	.00033	.00000	.00000	.00000
9,000	.00033	.00000	.00033	.00000	.00000	.00000
10,000	.00033	.00000	.00033	.00000	.00000	.00000
11,000	.00033	.00000	.00033	.00000	.00000	.00000
12,000	.00033	.00000	.00033	.00000	.00000	.00000
13,000	.00033	.00000	.00033	.00000	.00000	.00000
14,000	.00033	.00000	.00033	.00000	.00000	.00000
15,000	.00033	.00000	.00033	.00000	.00000	.00000
16,000	.00067	.00034	.00067	.00034	.00000	.00000
17,000	.00067	.00000	.00067	.00000	.00000	.00000
18,000	.00067	.00000	.00067	.00000	.00000	.00000
19,000	.00133	.00066	.00100	.00033	.00033	.00033
20,000	.00233	.00100	.00100	.00000	.00133	.00100
21,000	.00300	.00067	.00100	.00000	.00200	.00067
22,000	.00400	.00100	.00100	.00000	.00300	.00100
23,000	.00467	.00067	.00100	.00000	.00365	.00067
24,000	.00533	.00066	.00100	.00000	.00433	.00066
25,000	.00633	.00100	.00133	.00033	.00500	.00067
26,000	.00700	.00067	.00133	.00000	.00567	.00067
27,000	.00767	.00067	.00133	.00000	.00633	.00066
28,000	.00900	.00133	.00100	— .00033	.00800	.00167
29,000	.00967	.00067	.00100	.00000	.00867	.00067
30,000	.01067	.00100	.00133	.00033	.00933	.00066
31,000	.01200	.00133	.00133	.00000	.01067	.00134
32,000	.01300	.00100	.00167	.00034	.01133	.00066
33,000	.01433	.00133	.00167	.00000	.01267	.00134
34,000	.01567	.00134	.00133	— .00034	.01433	.00166
35,000	.01700	.00133	.00133	.00000	.01567	.00134
36,000	.01800	.00100	.00133	.00000	.01667	.00100
37,000	.01967	.00167	.00133	.00000	.01833	.00156
38,000	.02133	.00166	.00167	.00034	.01967	.00134
39,000	.02433	.00300	.00167	.00000	.02267	.00300
40,000	.02567	.00134	.00267	.00000	.02400	.00133
41,000	.02733	.00166	.00167	.00000	.02567	.00167
42,000	.02867	.00134	.00167	.00000	.02700	.00133
43,000	.03033	.00166	.00200	.00033	.02833	.00133
44,000	.03300	.00267	.00233	.00033	.03067	.00234
45,000	.03433	.00133	.00200	— .00033	.03233	.00166
46,000	.03900	.00467	.00233	.00033	.03667	.00434
47,000	.04167	.00267	.00233	.00000	.03933	.00266
48,000	.04367	.00200	.00233	.00000	.04133	.00200
49,000	.04700	.00333	.00267	.00014	.04433	.00300
50,000	.05100	.00400	.00300	— .00067	.04900	.00467
51,000	.05333	.00433	.00300	.00100	.05233	.00333
52,000	.05667	.00534	.00233	— .00067	.05633	.00600
53,000	.06667	.00600	.00300	.00067	.06367	.00534
54,000	.06867	.00200	.00233	— .00067	.06633	.00266
55,000	.07867	.00100	.00300	.00067	.07567	.00934
56,000	.08333	.00466	.00300	.00000	.08033	.00466
57,000	.09500	.01167	.00300	.00000	.09200	.01167
58,000	.10233	.00733	.00333	.00033	.09900	.00700
59,000	.11800	.01567	.00333	.00000	.11467	.01567
60,000	.13700	.01900	.00367	.00034	.13333	.01866
61,000	.17900	.03200	0.04000	0.00033	0.16500	0.03167
62,000	0.30367	0.13467	(*)	(*)	(*)	(*)

* Specimen broke.

GENERAL SUMMARY.

Tensile Strength per sq. in.	62,000 lbs.	Original area of cross-section. . . sq. in.	0.3038
Elastic limit.	19,000 lbs.	Area after rupture.	sq. in. 0.1611
Extension per in., at elastic limit. . . .	0.00133 in.	Position of rupture	1/8 from shoulder.
Extension per in. at rupture.	0.30367 in.	Character of fracture.	Fibrous.

The following are given by Kent * as the figures resulting from a test of cast-iron :

TABLE LI.

RECORD OF TEST OF CAST IRON.

Length, 5'' (12.7 centimetres) ; Diameter, 1.125'' (2.86 centimetres).

LOAD.	EXTENSION IN FIVE INCHES.			COEFFICIENT OF ELASTICITY.
	Right hand.	Left hand.	Mean.	
Lbs. per sq. in.	Inch.	Inch.	Inch.	
500	0.0007	— 0.0005	0.0001	25,000,000
1,000	0.0010	— 0.0006	0.0002	25,000,000
1,400	0.0012	— 0.0005	0.0003	23,333,333
2,000	0.0014	— 0.0003	0.0006	16,666,667
2,500	0.0015	0.0000	0.0008	15,625,000
3,000	0.0017	0.0003	0.0010	15,000,000
4,000	0.0026	0.0000	0.0013	15,384,615
5,000	0.0024	0.0011	0.0018	13,888,889
6,000	0.0027	0.0016	0.0022	13,636,364
7,000	0.0032	0.0019	0.0026	13,076,923
8,000	0.0035	0.0028	0.0032	12,500,000
9,000	0.0039	0.0034	0.0037	12,162,162
10,000	0.0044	0.0038	0.0041	12,195,119
11,000	0.0050	0.0044	0.0047	11,702,128
12,000	0.0053	0.0055	0.0054	11,250,000
13,000	0.0057	0.0061	0.0059	11,016,949
14,000	0.0066	0.0066	0.0066	10,606,061
15,000	0.0074	0.0076	0.0075	10,000,000
16,000	0.0083	0.0086	0.0085	9,411,706
17,000	0.0090	0.0093	0.0092	9,239,130
18,000	0.0097	0.0104	0.0101	8,910,891
19,000	0.0108	0.0116	0.0112	8,482,143
20,000	0.0120	0.0130	0.0125	8,000,000
21,000	0.0134	0.0145	0.0140	7,500,000
22,000	0.0152	0.0168	0.0160	6,875,000
23,000	0.0171	0.0197	0.0184	6,140,218
23,285	Broke.			

The extensions were measured on both sides the specimens, and the amount of its bending was thus determined. The ultimate resistance was 23,285 pounds per square inch (1,537 kilogrammes per square centimetre); the coefficient, or modulus of elasticity, as obtained by dividing the load by the

* *Van Nostrand's Magazine*, Vol. 20.

extension per unit of length was $\frac{5 \times 1,000}{.0002} = 25,000,000$ pounds per square inch (1,757,500 kilogrammes per square centimetre) at the start, but steadily diminished to one fourth that value at the point of fracture.

TABLE LII.—RECORD OF TESTS BY IMPACT OF FAG-ENDS OF 2-INCH BARS, ROLLED DOWN TO 1½-INCH.

NUMBER OF TESTS.	DIAMETER.	FIRST BLOW.		REMARKS.	NUMBER OF TESTS.	DIAMETER.	FIRST BLOW.		REMARKS.
		Work, foot-pounds.	Effect and deflection.				Work, foot-pounds.	Effect and deflection.	
1	1 1/4"	3,000	□	Slightly fire cracked.	44	1 1/4"	3,000	□	Rejected; steely.
2	1 1/4"	3,000	V.	Good.	45	1 1/4"	3,000	S. C.	All gray.
3	1 1/4"	3,000	V.	Do.	46	1 1/4"	3,000	□	Fine, steely; rejected.
4	1 1/4"	3,000	Do.	47	1 1/4"	3,000	B. C.	End hanging.
5	1 1/4"	3,000	S. C.	Slight fire cracks.	48	1 1/4"	3,000	B. C.	Screw.
6	1 1/4"	3,000	S. C.	Do.	49	1 1/4"	3,000	□	Fine, steely.
7	1 1/4"	3,000	C.	Very good.	50	1 1/4"	3,000	V.	Slight fire cracks.
8	1 1/4"	3,000	C.	Do.	51	1 1/4"	3,000	S. C.	Fire cracked slightly.
9	1 1/4"	3,000	C.	Very slight fire cracks,	52	1 1/4"	3,000	B. C.	All gray fibre.
10	1 1/4"	3,000	F.	90 per cent. gray.	53	1 1/4"	3,000	B. C.	Do.
11	1 1/4"	3,000	V.	Do.	54	1 1/4"	3,000	□	50 per cent. bright.
12	1 1/4"	3,000	V.	Slight fire cracks.	55	1 1/4"	3,000	□	All gray; very dark.
13	1 1/4"	3,000	Half in two; gray fibre.	56	1 1/4"	5,000	C.	All gray; good piece.
14	1 1/4"	3,000	□	Fine, steely.	57	1 1/4"	3,000	C.	All gray.
15	1 1/4"	3,000	V.	Good.	58	1 1/4"	3,000	S. C.	Do.
16	1 1/4"	3,000	S. C.	Do.	59	1 1/4"	3,000	Half in two; long fibre.
17	1 1/4"	3,000	S. C.	Do.	60	1 1/4"	3,000	Dull gray; rejected.
18	1 1/4"	3,000	S. C.	Do.	61	1 1/4"	3,000	□	50 per cent. bright.
19	1 1/4"	3,000	S. C.	Do.	62	1 1/4"	3,000	V.	Slight fire cracks.
20	1 1/4"	3,000	□	Short, bright steely.	63	1 1/4"	3,000	F.	End hanging.
21	1 1/4"	3,000	S. C.	Gray fibre.	64	1 1/4"	3,000	B. C.	Gray fibre.
22	1 1/4"	3,000	V.	Slight fire cracks.	65	1 1/4"	3,000	B. C.	Gray fibre; end hanging.
23	1 1/4"	3,000	V.	Gray fibre.	66	1 1/4"	3,000	S. C.	Long fibre.
24	1 1/4"	3,000	S. C.	Do.	67	1 1/4"	3,000	F.	Half in two; long fibre.
25	1 1/4"	3,000	□	50 per cent. bright.	68	1 1/4"	3,000	□	98 per cent. gray fibre;
26	1 1/4"	3,000	V.	Very good.					short.
27	1 1/4"	3,000	B. C.	All gray.	69	1 1/4"	3,000	C.	90 per cent. gray fibre.
28	1 1/4"	3,000	□	90 per cent. bright.					short.
29	1 1/4"	3,000	F.	98 per cent. gray.	70	1 1/4"	3,000	□	All gray fibre; short.
30	1 1/4"	3,000	V.	Good.	71	1 1/4"	3,000	V.	Long fibre.
31	1 1/4"	3,000	S. C.	Do.	72	1 1/4"	3,000	□	Fine, bright steely.
32	1 1/4"	3,000	S. C.	Slight fire cracks.	73	1 1/4"	3,000	115°	Thread chased on it; bent
33	1 1/4"	3,000	□	Fine, steely.					double.
34	1 1/4"	3,000	V.	Gray fibre: good.	74	1 1/4"	3,000	□	Fine, steely.
35	1 1/4"	3,000	V.	Do.	75	1 1/4"	3,000	□	Short gray fibre.
36	1 1/4"	3,000	B. C.	Do.	76	1 1/4"	3,000	V.	Fire cracked.
37	1 1/4"	3,000	C.	Do.	77	1 1/4"	3,000	V.	Do.
38	1 1/4"	3,000	C.	Do.	78	1 1/4"	3,000	V.	Do.
39	1 1/4"	3,000	C.	Do.	79	1 1/4"	3,000	F.	End hanging.
40	1 1/4"	3,000	C.	95 per cent. dull gray.	80	1 1/4"	3,000	B. C.	Long fibre.
41	1 1/4"	3,000	□	Steely.	81	1 1/4"	3,000	S. C.	Do.
42	1 1/4"	3,000	T. B.	Long fibre.	82	1 1/4"	3,000	V.	Slight fire cracks.
43	1 1/4"	3,000	T. B.	Do.	83	1 1/4"	3,000	V.	Do.

Temperature, 95°, 19.5°, and 24° Fahr. at 7 35 A. M., noon, and 4-35 P. M.
Nos 48 and 73 were, before being tested, made into screws.

Table LII. is a record of tests of cable irons by impact :

SYMBOLS USED IN THE TABLE.

The symbols by which the effects of the blows are described are given by the Committee thus :

“V.”—A fine silvery line has become visible on the lower part of the score, indicating an approach to

“S. C.”—A slight crack, in which a needle-point could be inserted.

“C.”—A crack wide and deep enough to insert the edge of a knife.

“+.”—An increase of the opening, but not enough to term

“B. C.”—A bad crack.

“F.” or “T. B.”—A fracture in which the ends are torn apart, leaving long, jagged splinters.

“ $\frac{1}{2}$ F.”—An incomplete fracture of the same nature, the ends still remaining connected.

“□.”—A short, square break, with little or no deflection, the fractured surfaces showing smooth, as though cut in two.

These examples are sufficient to illustrate the method of recording data.

226. Records and Use of Autographic Machines.—Table LIII., following, illustrates the use of the Autographic Machine in securing data, by test of a collection of tool steels examined for the Committee on Tool Steels of the U. S. Board testing metals. The angles of torsion and diameters of test-piece are denoted by θ and H , as before.

Analyses of these steels are given in the section on composition of steels.

227. Tenacity of Irons.—The composition and structure of the material, as has been already stated, modifies the tenacity of iron and steel. Good wrought iron varies in tenacity from 40,000 pounds per square inch (2,812 kilogrammes per square centimetre) upward, and this variation

TABLE LIII.—TESTS BY TORSION.

Specimens made from round bar, 1" diameter.

STEEL.	STIFFNESS.	RESILIENCE.	MODULUS OF ELASTICITY.	MODULUS OF RESISTANCE TO TORSION.			RELATIVE VALUE OF—					
				Elastic. $A_e = \frac{M'^4}{H^{30}e}$	Proof. $A' = \frac{M'}{H^3}$	Ultimate. $A = \frac{M}{H^3}$	Stiffness.	Resilience.	Relative elasticity.	Elastic. $A_e = \frac{M'^4}{H^{30}e}$	Proof. $A' = \frac{M'}{H^3}$	Ultimate. $A = \frac{M}{H^3}$
A.....	82.440	243.295	51,442,047	1443.56	557.22	1742.08	.9453	.5766	1.0000	.9417	.6185	.9256
B.....	71.905	421.920	47,561,542	1247.85	507.33	1538.42	.8245	1.0000	.9033	.8141	.5631	.8174
C.....	57.710	222.220	37,534,285	1007.44	658.39	1563.31	.6617	.5267	.7129	.6572	.7308	.8306
D.....	72.090	251.150	40,786,044	1259.48	458.55	1246.25	.8266	.5953	.7748	.8216	.5090	.6622
E.....	71.820	364.540	39,408,088	1256.48	497.63	1607.65	.8235	.8640	.7486	.8196	.5524	.8542
F.....	87.210	318.710	40,747,559	1532.97	737.38	1882.06	1.0000	.7554	.7740	1.0000	.8185	1.0000

continues, as carbon is added, through the several grades of steel until more than 200,000 pounds per square inch (14,060 kilogrammes per square centimetre) is attained. Cast iron varies from 10,000 pounds per inch (703 kilogrammes per square centimetre) to above 40,000 (2,812 kilogrammes per square centimetre), according to purity and physical character. The figures in Table LV. will exhibit these variations of composition, as observed in 2-inch bars (5.08 centimetres) of so-called standard irons under usual conditions, and when tested in pieces of standard form, as determined by Beardslee, for the U. S. Board testing Iron and Steel.*

These irons, when tested, gave the following figures for tenacity and ductility:

TABLE LIV.

RELATIVE VALUES OF BAR-IRONS, IN TENACITY, REDUCTION OF AREA, AND ELONGATION.

ORDER OF VALUE.	TENACITY. <i>T</i>			REDUCTION OF AREA.		ELONGATION.	
	Iron.	Pounds per sq. in.	Kilos. on sq. cm.	Iron.	Per Cent.	Iron.	Per Cent.
1	A	66,598	4,682	P	54.2	I	29.9
2	B	58,050	4,110	M	48.0	F	23.2
3	C	56,673	3,983	I	48.9	P	22.7
4	D	56,001	3,937	O	48.1	M	22.2
5	E	55,932	3,932	J	47.8	K	22.0
6	F	54,775	3,851	F	46.6	O	21.9
7	G	54,329	3,819	K	46.2	H	21.8
8	H	54,271	3,815	H	45.3	E	21.0
9	I	54,091	3,803	C	43.8	C	20.9
10	J	53,292	3,746	E	38.2	G	20.2
11	K	53,107	3,726	D	38.1	J	18.2
12	L	52,704	3,709	B	38.0	D	18.0
13	M	52,579	3,696	L	36.1	B	17.9
14	N	51,754	3,638	G	33.0	L	17.2
15	O	51,153	3,596	A	30.4	N	12.6
16	P	51,134	3,595	N	25.9	A	8.3

A comparison of these results with the data given in the

* Report, p. 250.

TABLE LV.—PRINCIPAL PHYSICAL AND CHEMICAL CHARACTERISTICS OF SIXTEEN IRONS.

	A	B	C	D	E	F	G	H	I	J	K	L	M	N	O	P
<i>a</i> Order in tenacity.....	1	2	3	4	5	6	7	8	9	10	11	12	13	14	15	16
<i>b</i> " in reduction of area.....	15	12	9	11	10	6	14	8	3	5	7	13	3	16	4	1
<i>c</i> " in elongation.....	16	13	9	12	8	2	10	7	1	11	5	14	4	15	6	3
<i>d</i> " in welding value.....	..	13	6	8	12	10	9	11	4	..	7	1	2	..	5	3
<i>e</i> " in power of resisting shocks.....	14	12	6	7	11	9	13	3	7	6	2	9	1	14	4	4
Average α to ϵ	8	7	6	7.5	7.5	6	10.5	8	6	7.5	9	12.5	7.5	15	9.5	8
Total average.....	11.5	10.2	8.6	8.5	8.8	8.6	10.6	5.4	4.8	8	6.4	10	4.4	15	7	5
	Per Cent.	Per Cent.	Per Cent.	Per Cent.	Per Cent.	Per Cent.	Per Cent.	Per Cent.	Per Cent.	Per Cent.	Per Cent.	Per Cent.	Per Cent.	Per Cent.	Per Cent.	Per Cent.
PERCENTAGES OF—																
Phosphorus.....	0.072	0.152	0.203	0.169	0.225	0.250	0.191	0.187	0.095	0.154	0.193	0.231	0.178	0.202	0.241	0.072
Silicon.....	0.095	0.149	0.147	0.154	0.184	0.182	0.169	0.163	0.028	0.160	0.163	0.156	0.130	0.271	0.160	0.072
Carbon.....	0.350	0.068	0.029	0.042	0.044	0.033	0.055	0.052	0.066	0.033	0.032	0.035	0.002	0.039	0.026	0.043
Copper.....	0.009	0.058	0.011	0.046	0.353	0.081	0.032	0.010	0.008	0.014	0.006	0.038	0.172	0.009	0.002	0.046
Manganese.....	0.014	0.022	0.030	0.021	0.020	0.033	0.038	0.031	0.009	0.084	0.039	0.037	0.031	0.023	0.048	0.006
Cobalt.....	0.008	0.019	0.026	0.029	0.070	0.037	0.029	0.026	0.020	0.023	0.042	0.047	0.068	0.006	0.018	0.032
Nickel.....	0.014	0.040	0.027	0.031	0.132	0.057	0.023	0.013	0.023	0.028	0.042	0.037	0.078	0.014	0.028	0.031
Slag.....	0.331	0.445	0.723	1.044	0.848	1.760	1.214	0.546	1.210	1.156	0.065	1.071

preceding table, will exhibit the influence of the several elements which are found in combination with iron, and will illustrate what has been stated in regard to their effect upon its valuable physical qualities. The irons which have lowest numbers in the general average (Table LV.), stand, on the whole, highest, and are seen to be those which, like those marked M, I, P, contain little phosphorus, silicon, or carbon, although in some cases containing considerable slag; those which best combine strength and ductility, are I, F, C, B, either very low in the hardening elements, as the first, or very well worked and free from slag, while containing a small proportion of hardening elements, as the last two. The worst specimen of all, N, is peculiar in its high figure for silicon (0.271); the best of all, M, has but 0.002 per cent. carbon. A study of these tables is instructive, and is the more valuable as these are as yet the only accessible data obtained by so complete a comparison of physical and chemical characteristics, and by the examination of a wide range of quality of wrought iron.

It will be noticed in the above, and in succeeding records of test, that the reduction of area, and, consequently, the ultimate resistance to stress measured per square inch of fractured section, is very variable. The soft irons and steels exhibit great reduction at the breaking section, while the hard irons and steels are very slightly reduced. The difference between the breaking stress per square inch of original, and per square inch of fractured, section is very considerable with the first, and very little with the second, class of metals, and the measurement by fractured area is evidently the better gauge of their quality. Kirkaldy would always class metals by the second method; in this matter the Author fully agrees with him.

228. The Tenacity of the Commercial Grades of Iron is not uniform, but they may be grouped roughly by classes, according to shape and dimensions, and average figures given for each class, which are subject to modification by all the conditions already noted.

•

The following figures are derived from experiments upon good examples of several grades of iron plate.

Sixteen experiments upon high-grade boiler plate resulted as follows : *

	Measures.	
	Metric.	British.
Average breaking weight	3,803	54,123
Highest " "	4,007	57,012
Lowest " "	3,642	51,813
Variation in <i>per centum</i> of highest.....	9.1	

Fifteen experiments made upon the best grades of flange irons gave :

	Measures.	
	Metric.	British.
Average breaking weight	2,960	42,144
Highest " "	3,746	53,277
Lowest " "	2,320	33,003
Variation in <i>per centum</i> of highest.....	38	

Six experiments upon hard Bessemer steel gave :

	Measures.	
	Metric.	British.
Average breaking weight	5,877	83,621
Highest " "	6,087	86,580
Lowest " "	5,237	74,509
Variation in <i>per centum</i> of highest.....	14	

Five experiments were made upon the best boiler plate :

	Measures.	
	Metric.	British.
Average breaking weight	4,177	58,984
Highest " "	4,710	64,000
Lowest " "	3,887	55,300
Variation in <i>per centum</i> of highest.....	14	

Six experiments upon samples of tank-iron, by three makers, gave :

	Measures.	
	Metric.	British.
Average breaking weight, Maker No. 1	3,079	43,831
Highest " " " "	3,739	53,174
Lowest " " " "	2,538	36,111
Variation in <i>per centum</i> of highest.....	32	

	Measures.	
	Metric.	British.
Average breaking weight, Maker No. 2	2,953	42,011
Highest " " " "	3,392	48,425
Lowest " " " "	5,510	35,679
Variation in <i>per centum</i> of highest	28	
Average breaking weight, Maker No. 3	2,896	41,249
Highest " " " "	3,676	52,277
Lowest " " " "	2,320	33,003
Variation in <i>per centum</i> of highest	38	

In another series, of which the results were supplied to the Author by Mr. C. Huston, the following figures were obtained:

TABLE LVI.

TESTS OF BOILER-PLATE.

NAME.	TENACITY. <i>T</i>		ELASTIC LIMIT.	
	Lbs. per sq. inch.	Kilogs. per sq. cm.	Lbs. per sq. inch.	Kilogs. per sq. cm.
"Best boiled"	55,000	3,550	31,500	2,214
"Best flange charcoal"	56,000	3,557	35,000	2,460
"Double-worked boiled"	40,000	2,812
"Best flange"	56,400	3,560	30,000	2,109

The figures are all higher than those usually expected by the engineer when buying iron.

The last mentioned grade had a tenacity per square inch of fractured section of 87,000 pounds (5,673 kilogrammes per square centimetre), and was reduced in section 20 per cent.

Best "C. H. No. 1" plate, $\frac{3}{8}$ th inch (0.95 centimetre) thick, tested by Kent, exhibited a tenacity of very nearly 60,000 pounds per square inch (4,218 kilogrammes per square centimetre) of original area, elongated 15 per cent., and its

resistance per square inch of fractured section was 76,000 pounds (5,378 kilogrammes per square centimetre.)

229. Variations of Tenacity with Size.—Bar-irons exhibit a wide difference of strength, due to difference of section alone. This variation may be expressed approximately with good irons, such as the Author has studied in this relation, by the formulas,

$$\left. \begin{aligned} T &= 56,000 - 20,000 \log d \\ T_m &= 4,500 - 1,406 \log d_m \end{aligned} \right\} \dots \dots (19)$$

Where T and T_m measure the tenacity in British and metric measures respectively, and d and d_m the diameter of the piece, or its least dimension.

Where it is desired to use an expression which is not logarithmic it will usually be safe to adopt in specifications the following:

$$T = \frac{60,000}{\sqrt[4]{d}}; \quad T_m = \frac{4,000}{\sqrt[4]{d}} \quad \dots \dots (20)$$

The Edgemoor Iron Company adopt, for wrought iron in tension, the formula,

$$T = 52,000 - \frac{7,000 A}{B},$$

in which A is the area, and B the periphery of the section.*

The experiments made by Beardslee for the United States Board gave results for rolled iron of various qualities, as follows: †

* *Ohio Railway Report*, 1881, p. 379.

† Report, 1878.

TABLE LVII.
TESTS OF CHAIN IRON.

CENTIMETRES.	DIAMETER, INCHES.	STRENGTH LBS. PER SQUARE INCH. T	KILOGRAMMES PER SQUARE CENTIMETRES. T_m	ELASTIC LIMIT LBS. PER SQUARE INCH.	KILOGRAMMES PER SQUARE CENTIMETRE.
.64		59,885	4,210
.96		54,090	3,578	40,980	2,881
1.27		52,275 to 62,700	3,675 to 4,408	39,126	2,751
1.59		52,050 to 57,660	3,687 to 4,053
1.90		51,546	3,624	35,933	2,490
2.22		50,630	3,559	33,931	2,382
2.54	1	51,400 to 61,727	3,613 to 4,339	31,300 to 39,230	2,200 to 2,756
2.70	1 $\frac{1}{8}$
2.86	1 $\frac{1}{4}$	50,149 to 60,458	3,525 to 4,250	26,787 to 41,311	1,881 to 2,900
3.02	1 $\frac{3}{8}$
3.18	1 $\frac{1}{2}$	50,040 to 59,461	3,518 to 4,181	27,643 to 39,608	1,943 to 2,784
3.32	1 $\frac{5}{8}$	54,518	3,833	35,898	2,522
3.50	1 $\frac{3}{4}$	50,594 to 58,926	3,557 to 4,142	25,930 to 39,103	1,823 to 2,749
3.66	1 $\frac{7}{8}$	50,400 to 53,944	3,543 to 3,792	32,411 to 32,655	2,278 to 2,291
3.81	1 $\frac{7}{8}$	49,292 to 57,317	3,465 to 4,029	27,708 to 38,417	1,948 to 2,701
3.97	1 $\frac{7}{8}$
4.13	1 $\frac{7}{8}$	49,030 to 57,402	3,447 to 4,035	27,695 to 35,889	1,947 to 2,524
4.18	1 $\frac{7}{8}$	49,821 to 57,789	3,502 to 4,063	33,145 to 38,310	2,330 to 2,694
4.45	1 $\frac{7}{8}$	49,738 to 57,874	3,496 to 4,068	26,541 to 36,572	1,765 to 2,572
4.60	1 $\frac{7}{8}$	48,953 to 56,577	3,441 to 3,977	29,767 to 33,565	2,095 to 2,360
4.76	1 $\frac{7}{8}$	47,478 to 55,803	3,338 to 3,823	23,250 to 35,641	1,634 to 2,505
4.91	1 $\frac{7}{8}$	51,242 to 51,707	3,602 to 3,633
5.08	2	46,151 to 60,213	3,244 to 4,233	27,318 to 36,184	1,920 to 2,544
5.24	2 $\frac{1}{8}$	49,422 to 51,539	3,473 to 3,623
5.40	2 $\frac{1}{8}$	48,324 to 51,225	3,401 to 3,601	30,459	2,141
5.56	2 $\frac{1}{8}$	51,666	3,632
5.82	2 $\frac{1}{8}$	46,866 to 51,530	3,295 to 3,623	28,241 to 32,163	1,985 to 2,204
6.35	2 $\frac{1}{8}$	47,344 to 48,475	3,328 to 3,408	28,932 to 28,941	2,024 to 2,105
6.98	2 $\frac{1}{4}$	46,446	3,265	26,333	1,851
7.62	3	47,761	3,358	26,400	1,856
8.28	3 $\frac{1}{4}$	47,014	3,405	24,591	1,720
8.90	3 $\frac{1}{4}$	47,000	3,294	34,961	1,662
9.54	3 $\frac{3}{4}$	46,667	3,381	23,636	1,641
10.16	4	46,322	3,256	23,430

General Deductions.—The figures in Table LVIII. have been taken by the Author as fair values of the tenacity of good average merchant iron.

Kirkaldy* found that pieces of 1 $\frac{1}{4}$ inch (3.2 centimetres)

* Experiments on Wrought Iron and Steel.

bar rolled down to 1 inch (2.54 centimetres), $\frac{3}{4}$ inch (1.9 centimetres) and $\frac{1}{2}$ inch (1.27 centimetres) diameter increased in tenacity 20 per cent. while decreasing in ductility 5 per cent.

TABLE LVIII.

TENACITY OF GOOD IRON.

DIAMETER.		TENACITY. <i>T</i>	
Centimetres.	Inches.	Lbs. per square inch.	Kilogrammes Per square inch.
.64	$\frac{1}{4}$	60,000	4,218
1.27	$\frac{1}{2}$	58,000	4,077
1.90	$\frac{3}{4}$	56,000	3,947
2.54	1	55,500	3,902
3.18	1 $\frac{1}{4}$	54,500	3,838
3.81	1 $\frac{1}{2}$	53,500	3,761
4.45	1 $\frac{3}{4}$	52,000	3,656
5.08	2	50,000	3,515
5.72	2 $\frac{1}{4}$	49,000	3,445
6.35	2 $\frac{1}{2}$	48,900	3,374
7.62	3	47,500	3,320
8.90	3 $\frac{1}{2}$	47,000	3,304
10.16	4	46,000	3,234
12.70	5	44,000	3,093

Forging has the same effect as rolling.

The elastic limit is also usually lower in large than in small masses, as is also the elongation.

230. Chain Iron.—The Committee on Chain Cables reporting to the United States Board appointed in 1875 to test iron, steel, etc., objected to the then standard cable proving-strains, asserting that as tension in excess will probably injure the cable, it becomes a matter of importance to fix upon a strain for each size which, while sufficient to secure the detection of unduly weak links, *will not produce such*. American manufacturers of cable use, for each size, a stress which is prescribed by the standard proof-table of the British

Admiralty, and their cables are sold with a guaranty that they have been so proved. The committee considers that, as applied to cables made from American bar-iron, this standard is faulty in two important respects:

(1.) The stress prescribed by it for every kind of cable is *too great*.

(2.) The stresses for the different sizes are unequal in their proportion to the strength of the links.

They assign the following reasons for these opinions:

(1.) The stress for all sizes is based upon the assumption that the cable-bolts of all diameters possess a strength equal to 60,000 pounds per square inch. Few bars of American iron are equal to this strength, and when they are their cost precludes their use as cable-iron; and, as has been shown in the investigations by tension, although this strength may be found in the small bars it is not found in the large sizes of the same iron.

(2.) If the bars of all sizes did possess this strength, the "proof" is still too great, for it probably exceeds by a considerable amount the *elastic*

limit of the links.

Testing iron cable of various sizes in short sections, Fig. 80, and comparing their strength with that of the bars from which they were made, they gave the following table (p. 411) as representing a calculated graded series of probable figures for tenacities and the results of actual tests.

Having thus fixed upon a suitable strength for each sized bar, they deduce the probable strength of cables made from them, by the aid of the percentages of the strength of bar which will probably be developed by the links, as indicated by such irons as they have examined.

In this table of strength of links it is considered that no iron should be expected to possess in link form over 170 per cent., that no suitable chain-iron should possess less than 155 per cent., of the strength of the bar, and that the average

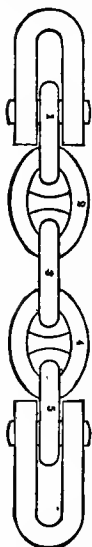

FIG. 80.—
TEST-
LINKS.

strength of a number of tested sections should not be less than 163 per cent. ; such average to be made from fairly uniform quality of iron.

TABLE LIX.

COMPARISON OF CALCULATED WITH ACTUAL STRENGTH OF BARS.

SIZE OF BAR.	STRENGTH.		DIFFERENCE.	NUMBER OF IRONS.	NUMBER OF TESTS.
	Calculated.	By actual tests.			
<i>Inches.</i>	<i>Pounds.</i>	<i>Pounds.</i>	<i>Pounds.</i>		
2	157,080	157,580	500	9	35
1 $\frac{1}{2}$	148,137
1 $\frac{3}{8}$	139,430	141,120	1,690	9	26
1 $\frac{1}{8}$	130,966	131,975	1,009	5	8
1 $\frac{1}{4}$	122,745	124,580	1,835	13	33
1 $\frac{1}{8}$	114,770	115,690	920	4	7
1 $\frac{1}{2}$	107,040	108,800	1,760	10	25
1 $\frac{3}{8}$	99,560
1 $\frac{1}{8}$	92,322	93,358	1,036	13	34
1 $\frac{1}{4}$	85,339	85,000	339	6	12
1 $\frac{3}{8}$	78,607	79,311	704	9	27
1 $\frac{1}{8}$	72,133	74,505	2,372	1	94
1 $\frac{1}{4}$	65,914	66,724	810	9	106
1 $\frac{3}{8}$	59,958
1 $\frac{1}{8}$	54,261	54,570	309	9	29
1 $\frac{1}{4}$	48,800
1	43,665	44,126	461	6	26

The table on the next page represents the variations of proof stress recommended compared with those previously in use. The new table was approved by the Navy Department.

The important points of difference between the recommended table and the one in use are :

(1.) In the former the proof-stress is for every size uniform in its proportion to the probable strength of the links, in the latter it varies with every change of size.

(2.) Unless the elastic limit of the link is a greater proportion of its ultimate strength than that of the bar was to its

strength, the strains of the table in use exceed this limit greatly upon all sizes, while those of the former do not.

TABLE LX.

COMPARISON OF THE PROVING-STRESSES RECOMMENDED AND STRAINS IN USE.

SIZE OF CABLE.	RECOMMENDED PROVING STRESS.	PROBABLE PERCENTAGE OF STRENGTH OF—		ADMIRALTY PROVING STRESS.	PROBABLE PERCENTAGE OF STRENGTH OF—	
		Strongest link.	Weakest link.		Strongest link.	Weakest link.
<i>Inches.</i>	<i>Pounds.</i>			<i>Pounds.</i>		
2	121,737	45.5	50	161,280	60.3	66.2
1 $\frac{1}{8}$	114,806	45.5	50	151,357	60.1	65.9
1 $\frac{3}{8}$	108,058	45.5	50	141,750	59.8	65.5
1 $\frac{1}{2}$	101,499	45.5	50	132,457	59.4	65.2
1 $\frac{3}{4}$	95,128	45.5	50	123,480	59.1	64.9
1 $\frac{5}{8}$	88,947	45.5	50	114,817	58.8	64.5
1 $\frac{7}{8}$	82,956	45.5	50	106,470	58.5	64.1
1 $\frac{9}{8}$	77,159	45.5	50	98,437	58.2	63.7
1 $\frac{1}{2}$	71,550	45.5	50	90,720	57.8	63.3
1 $\frac{3}{4}$	66,138	45.5	50	83,317	57.4	62.9
1 $\frac{5}{8}$	60,920	45.5	50	76,230	57.0	62.5
1 $\frac{7}{8}$	55,903	45.5	50	69,457	56.6	62.1
1 $\frac{1}{4}$	51,084	45.5	50	63,000	56.2	61.6
1 $\frac{3}{8}$	46,468	45.5	50	56,857	55.7	61.1
1 $\frac{1}{2}$	42,053	45.5	50	51,030	55.3	60.6
1 $\frac{3}{4}$	37,820	45.5	50	45,517	54.8	60.1
1	33,840	45.5	50	40,320	54.3	59.5

(3.) The recommended table recognizes the probability of there being introduced into cables links made from bars which, although of equally good iron as the rest, are, through faults in rolling, more or less *scant*, and in consequence possess less strength than bars rolled true, which deficiency will be carried into the links. Should there be by accident a few links of 1 $\frac{1}{8}$ " in a 2" cable, the Admiralty proof would strain the strongest of such links to over 62 per cent., and the weakest to over 70 per cent. of the actual strength.

The heating and working of iron in making chains or other

finished work reduces their carbon, eliminates phosphorus and other oxidizable elements, and thus reduces tenacity and elastic resistance, and often introduces oxide and produces silicates which injure the welding qualities and reduce ductility. These alterations are often so great that it happens that the best bar, as gauged by the accepted standard test, does not make the best chain or finished rod. The strongest bar is very apt to make the weakest chain.

A link of chain cable has the form seen in Fig. 81, and if made of strong and consequently of hard iron, is likely to break on the "quarter weld" in the sketch. The weld end is usually most likely to yield, while the butt rarely breaks. With some soft grades of iron, the studded link shown is, contrary to the commonly accepted opinion, much weaker than the same link with the stud omitted. With coarse, hard, brittle iron, this difference is less observable. The stud serves to hold the sides of the link apart and to prevent "gripping," and the production of a stiff stretch of chain under heavy strain, and also to reduce the danger of a "kink."

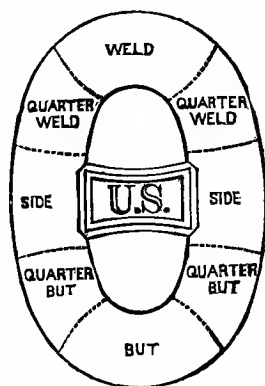

FIG. 81.—STUDED LINK.

Chains were found to differ 17 to 25 per cent. in strength when nominally alike. The most perfect uniformity of quality should be demanded in such work. The usual strength of a good cable is 160 to 165 per cent. of that of the bar used in making it, often falling, in less excellent grades, to 150, and sometimes rising to 170. Low tenacity gives good welding quality, and makes the best welded work. The proof-strain should be made very nearly the minimum elastic limit permitted.

231. Wire.—Tests of small sizes of iron wire of good quality, down to the finest of common wire, as made for the Author by William Hewitt, gave the following figures :

TABLE LXI.
TENACITY OF IRON WIRE.

NO.	ORIGINAL DIAMETER.		FINAL.		TENACITY.	
	Inches.	Centi- metres.	Inches.	Centi- metres.	Lbs. per sq. in.	Kilogs. per sq. cm.
10	.1340	.340	.1330	.338	92,890*	6,530
11	.1205	.305	.1185	.303	84,442†	5,936
12	.1040	.255	.1010	.257	93,158	6,555
13	.0925	.225	.0920	.234	100,297*	7,050
14	.0800	.203	.0795	.203	94,299	6,629
15	.0710	.178	.0680	.173	98,384‡	6,915
16	.0640	.163	.0635	.161	93,876	6,600
17	.0535	.139	.0532	.135	105,871	7,442
18	.0465	.118	.0400	.101	119,536§	8,403
19	.0385	.098	.0385	.098	87,617	6,159
20	.0335	.085	.0335	.085	111,184	7,816
21	.0290	.074	.0290	.074	113,546	7,982

The tenacity of "medium soft" telegraph wire may be taken as follows, for the several sizes obtainable in the market :

TABLE LXII.
TENACITY OF IRON TELEGRAPH WIRE.

NO. B. W. G.	DIAMETER.		WEIGHT PER YARD OR METRE.		TENACITY. <i>T</i>	
	In.	Cm.	Lbs.	Kilogs.	Lbs.	Kilogs.
1	0.30	0.76	0.688	0.313	4,000	1,800
2	0.28	0.70	0.599	0.272	3,400	1,500
3	0.26	0.66	0.517	0.235	2,900	1,300
4	0.24	0.61	0.440	0.200	2,500	1,150
5	0.22	0.56	0.370	0.170	2,200	1,000
6	0.20	0.50	0.305	0.139	1,800	800
7	0.19	0.48	0.262	0.119	1,500	650
8	0.17	0.43	0.221	0.100	1,200	550
9	0.16	0.40	0.184	0.084	950	440
10	0.14	0.35	0.150	0.068	800	360
12	0.11	0.28	0.092	0.042	500	230
14	0.09	0.23	0.055	0.025	350	160
16	0.07	0.18	0.032	0.015	200	90

* Hard drawn. † Soft. ‡ Soft : Extension, 0.12½. § Very hard. Comparison sample of Norway iron, very soft, broke at just one-half this figure.

HOMOGENEITY OF OPEN-HEARTH METAL. (H. H. CAMPBELL.)

Heat 10,699. Acid Open Hearth. Test-bars, $\frac{1}{4}$ " Rolled Rounds.				Heat 10,910. Acid Open Hearth. Test-bars, $\frac{1}{4}$ " Rolled Rounds.			
Elastic Limit. Lbs. per Sq. In.	Ultimate Strength. Lbs. per Sq. In.	Elong. in 8 In. Per Cent.	Reduct. of Area. Per Cent.	Elastic Limit. Lbs. per Sq. In.	Ultimate Strength. Lbs. per Sq. In.	Elong. in 8 In. Per Cent.	Reduct. of Area. Per Cent.
35,900	53,510	28.75	64.14	31,140	52,760	32.75	60.60
36,450	54,790	31.75	64.58	31,790	52,750	32.75	61.20
36,000	56,150	28.75	62.71	31,540	53,000	31.50	56.50
36,225	55,600	31.25	64.48	31,250	52,000	32.25	63.30
36,090	55,830	31.00	64.71	31,250	52,320	34.00	64.10
36,315	55,830	32.00	65.18	31,080	52,320	32.50	57.10
36,740	56,370	31.50	64.84	31,160	52,830	32.75	61.80
36,350	55,090	29.50	62.87	31,250	53,160	32.75	58.10
36,450	57,510	31.25	64.25	31,040	52,160	32.75	61.80
36,125	56,900	30.75	64.26	32,050	53,840	32.50	59.60
37,580	56,600	33.50	64.16	31,660	53,580	32.50	61.10
36,900	57,510	30.50	65.16	31,700	52,480	32.25	53.10
37,220	57,420	31.25	63.28	32,550	52,580	34.00	63.10
37,130	57,280	31.75	64.16	32,570	52,960	32.75	65.40
36,000	57,050	31.25	65.75	33,330	53,050	33.00	60.40
35,860	57,190	31.25	64.23	33,580	53,860	33.00	60.40
36,615	57,440	31.25	64.74
36,450	57,670	31.75	66.46
37,165	57,580	32.75	63.68
36,640	57,350	31.25	63.18
Av. 36,510	56,538	31.15	64.34	Av. 31,809	52,853	32.75	60.48

Heat 11,018. Acid Open Hearth. Test-bars, $\frac{1}{4}$ " Rolled Rounds.				Heat 1,820. Basic Open Hearth. Test-bars, $\frac{1}{4}$ " Rolled Rounds.			
Elastic Limit. Lbs. per Sq. In.	Ultimate Strength. Lbs. per Sq. In.	Elong. in 8 In. Per Cent.	Reduct. of Area. Per Cent.	Elastic Limit. Lbs. per Sq. In.	Ultimate Strength. Lbs. per Sq. In.	Elong. in 8 In. Per Cent.	Reduct. of Area. Per Cent.
36,700	58,400	28.00	66.20	33,065	48,340	34.50	71.87
37,150	57,840	30.75	65.60	31,530	47,380	35.00	72.05
37,280	56,880	29.50	58.60	33,650	48,450	35.00	72.05
36,060	56,940	28.50	53.30	31,600	48,230	37.00	74.14
36,420	56,700	30.75	63.10	33,340	49,175	36.25	70.09
36,060	57,180	30.25	65.50	32,760	48,560	33.75	72.95
35,780	56,800	31.00	65.40	33,260	47,730	35.00	74.49
36,700	57,440	30.00	63.80	32,130	48,785	34.00	71.80
35,780	56,800	31.00	65.40	32,935	48,640	34.25	71.92
36,700	57,440	30.00	63.80	33,270	49,440	34.00	71.48
35,700	56,900	32.50	67.10	32,900	47,835	34.00	72.72
37,020	57,180	31.25	59.70	31,920	48,050	33.75	71.42
37,400	57,320	30.50	68.10	32,185	48,360	36.25	74.28
37,260	56,780	30.25	67.20	33,880	48,400	33.75	73.64
37,480	57,420	31.00	66.30
Av. 36,634	57,201	30.35	63.94	Av. 32,745	48,384	34.75	72.49

Very soft and pure wire will have 20 or 25 per cent. less tenacity than is above given, while hard wire may give figures exceeding the above by an equal amount. In consequence of this variability it would be useless to express tenacities more precisely. *Turning iron down* has no important effect on the tenacity.

The considerable variations always observable in the general rate of increase of tenacity, which, other things being equal, accompanies reduction of size of wire, are due to the hardening of the wire in the draw-plate, and occasional restoration to its softest condition by annealing.

Beardslee has found the change of tenacity in forged and rolled bars, above noted, to be due to differences in amount of work done in the mill upon the iron. The extent of reduction of the pile sent to the rolls from the heating furnace is variable, its cross-sectional area being originally from 20 to 60 times that of the bar, the higher figure being that for the smallest bars. On making this reduction uniform, it is found that the tenacity of bars varies much less, in different sizes, and that the change becomes nearly uniform from end to end of the series of sizes, and becomes also very small in amount. By properly shaping the piles at the heating furnace, and by putting as much work on large as on small bars, it was found that a 2-inch (5.08 centimetres) bar could be given a strength superior by over 10 per cent., and a 4-inch (10.17 centimetres) could be made stronger by above 20 per cent. than iron of those sizes as usually made for the market. The surface of a bar is usually somewhat stronger than the interior.

The Limit of Elasticity will be found at from two-fifths the ultimate strength in soft, pure irons, to three-fifths in harder irons, and from three-fifths in the steels to nearly the ultimate strength with harder steels and cast irons. Barlow found good wrought iron to elongate one ten-thousandth its length per ton per square inch up to the limit at about 10 tons. The relation between the *series* of elastic limits, and the maximum resistance of the iron or the steel is well shown in strain-diagrams, which exhibit graphically the varying

relation of the stress applied to the strain produced by it throughout the process of breaking.

232. Experiments on Long Bars are seldom made, and but few are on record.

The following data were obtained from tests made for the Phoenix Iron Company :

TABLE LXIII.
TESTS OF LONG BARS OF WROUGHT IRON.

NUMBER OF BARS.	SIZE.	LENGTH.	STRETCH. INCHES.	MODULUS OF ELASTICITY. E
23	3 × $\frac{7}{8}$	35' 0"	.2587	32,470,000
24	$3\frac{1}{2}$ × $1\frac{1}{2}$	35' 0"	.2617	32,098,000
9	4 × $1\frac{3}{8}$	27' 6"	.2033	32,464,700
24	$3\frac{1}{2}$ × $1\frac{1}{4}$	35' 0"	.2500	33,600,000
24	3 × $1\frac{3}{4}$	35' 0"	.2633	31,902,000
12	4 × $1\frac{3}{8}$	35' 0"	.2692	31,203,000
24	2 × I	24' $9\frac{1}{2}$ "	.1948	30,544,000
36	$2\frac{7}{8}$ "	11' 9"	.0953	29,380,000
48	$2\frac{1}{2}$ "	11' 9"	.0955	29,319,000
68	$2\frac{1}{2}$ "	11' 11"	.0998	28,056,000
48	$2\frac{1}{8}$ "	11' 9"	.1008	27,777,777
72	$2\frac{3}{8}$ "	11' 9"	.0940	29,787,000
120	$2\frac{5}{8}$ "	11' 9"	.0947	29,567,000

233. Repeatedly Piling and Reworking improves the quality of wrought iron up to a limit at which injury is done by overworking and burning it. Clay's experiments on good fibrous puddled iron repiled, reheated, and reworked, resulted as shown in the table on next page.*

The iron thus treated exhibits increasing strength until it has been reheated five or six times, and then gradually loses tenacity at a rate which seems to be an accelerating one. Forging iron is similar in effect, and improves the metal up to a limit seldom reached in small masses.

The forging of large masses usually includes too often repeated piling and welding of smaller pieces, and it is thence

* Fairbairn, p. 249.

found difficult to secure soundness and strength. This is particularly the case where the forging is done with hammers of insufficient weight. The iron suffers, not only from reheating, but from the gradual loosening and weakening of the cohesion of the metal within the mass at depths at which the beneficial effect of the hammer is not felt.

TABLE LXIV.

EFFECT OF REHEATING.

NUMBER.	QUALITY.	TENACITY.	
		Pounds per square inch.	Kilogrammes per square centimetre.
1	Puddled Bar.	43,904	3,086
2	Piled and reheated.	52,864	3,718
3	Repiled and reheated.	59,585	4,190
4	" " "	59,585	4,190
5	" " "	57,344	4,028
6	" " "	61,824	4,344
7	" " "	59,585	4,190
8	" " "	57,344	4,028
9	" " "	57,344	4,028
10	" " "	54,104	3,802
11	" " "	51,968	3,655
12	" " "	43,904	3,086

The effect of prolonged heating is sometimes seen in a granular, or even crystalline, structure of the iron, which indicates serious loss of tenacity. Large masses must always be made with great care, and used with caution and with a high factor of safety. Ingot iron is always to be preferred to welded masses of forged material for shafts of steamers and similar uses.

234. The Tenacity of Ingot Irons and Steels is less subject to variation by accidental modifications of structure and composition than is that of wrought iron. The steels are usually homogeneous and well worked, and are comparatively free from objectionable elements, their variation in quality being determined principally by the amount of carbon present, which element occurs in a proportion fixed by the maker,

and varying within a very narrow range. The softest grades of ingot iron and steel approach the character of wrought irons; but their comparative freedom from slag, and their purity, usually make them superior to all ordinary irons in combined strength and ductility. The products of the Bessemer and of the open-hearth processes vary in tenacity from 60,000 pounds per square inch (4,218 kilogrammes per square centimetre) to more than double that figure; while the crucible steels often, and occasionally the preceding, are sometimes four times as strong, a tenacity of 200,000 pounds per square inch (14,060 kilogrammes per square centimetre) being sometimes exceeded.

TABLE LXV.

CHEMICAL ANALYSES OF INGOT IRONS AND STEELS.

Arranged according to per cent. of Carbon.

NUMBER.	CARBON.			SULPHUR.	PHOSPHORUS.	SILICON.	MANGANESE.	COPPER.	COBALT.	NICKEL.	REMARKS.
	Total.	Combined.	Graphitic.								
1	.009009	.084	.163	.020	.023	.021	.016	
2	.057	.049	.008	.007	.179	.219	.063	.013	.075	.055	
3	.130	.116	.014	.029	.045	.011	.192	.002	trace	trace	
4	.234	.230	.004	trace	.039	.084	none	.014	.036	.057	.115 Antimony.
5	.238012	.034	.105	.184	.022	.016	.021	
6	.401006	.032	.085	.112	.008	.021	.026	
7	.463002	.020	.121	trace	.003	.018	.018	
8	.577	.459	.118	.026	.108	.108	.185	none	trace	none	
9	.639	.627	.012	trace	.007	.154	.050	.008	"	"	1.044 Chromium.
10	.691	.675	.016	.028	.065	.028	.459	.022	"	trace	
11	.756	.744	.012	.043	.104	.074	.465	.346	.052	.120	
12	.806	.793	.013	none	.019	.172	.193	none	none	none	
13	.873	.833	.040	trace	.015	.134	.046	.003	trace	.023	
14	.923	.908	.015	.002	.014	.141	.036	.003	"	.018	
15	.996	.984	.008	none	.019	.157	.245	trace	"	none	
16	1.072	1.059	.013	"	.022	.162	.252	"	"	"	
17	1.121	1.108	.013	"	.023	.206	.269	"	"	"	
18	1.154	1.142	.012	"	.020	.204	.282	"	"	"	
19	1.328	1.244	.084	"	.017	.246	.262	none	"	"	

An investigation of the qualities of the various grades of

ingot iron and steel, and especially as affected by variation of composition, was undertaken, 1875-78, by the "U. S. Board testing Iron, Steel, and other Metals," which was interrupted by the failure of needed appropriations. The foregoing selected samples of steel tested for the Committee on Chemical Research by the Author, exhibited the widest range of composition, from that of the softest ingot iron to the hardest tool steel (Table LXV.).

These steels were tested in the manner already described, with the result exhibited in the next table. A comparison of the two sets of data will exhibit the influence of variation of composition upon tenacity, as well as the wide range of composition of these ingot metals as found in the market.

TABLE LXVI.

TENACITY OF INGOT IRONS AND STEELS.

NUMBER.	ELONGATION.	ELASTIC LIMIT.		ULTIMATE STRENGTH.		MODULUS OF ELASTICITY. <i>E</i>	
		Kilogs. per sq. cm.	Lbs. per sq. in.	Kilogs. per sq. cm.	Lbs. per sq. inch.	Kilogs. per square cm.	Lbs. per sq. inch.
	Per cent.						
1	29.67	1,683	26,500	3,123	43,000	1,801,859	25,631,000
2	25.50	2,425	34,500	3,867	55,000	1,566,706	22,286,000
3	34.33	2,004	28,500	3,656	52,000	1,974,376	28,085,000
4	20.83	1,828	26,000	4,218	60,000	1,913,288	27,216,000
5	12.00	3,473	49,400	4,900	69,700	1,727,793	24,576,000
6	21.67	3,567	50,743	5,012	71,300	1,989,209	28,296,000
7	20.17	2,840	44,000	4,991	71,000	1,657,127	23,558,000
8	19.50	3,359	47,800	5,842	83,100	1,847,836	26,285,000
9	2.75	3,515	50,000	6,643	94,500	1,833,143	26,076,000
10	3.58	3,550	50,500	7,100	101,000	2,051,987	29,189,000
11	1.00	4,583	65,190	7,128	101,400	1,616,900	23,000,000
12	9.75	3,550	50,500	7,902	112,400	2,054,368	29,223,000
13	8.17	3,550	50,500	7,951	113,100	1,833,143	26,076,000
14	11.08	3,585	51,000	8,349	118,900	1,805,374	25,681,000
15	10.08	4,352	61,900	8,591	122,200	1,853,936	26,386,000
16	7.67	4,787	68,100	8,647	123,000	1,915,876	27,252,000
17	8.08	4,787	68,100	8,823	125,500	1,939,155	27,584,000
18	8.67	5,287	75,200	9,166	130,380	1,880,174	26,745,000
19	7.33	5,294	75,300	9,412	135,300	1,936,203	27,542,000

A singular uniformity of tenacity and of elastic limit is

observed within limited ranges of quality, with sudden changes at the limits of each range. On the whole, a gradual increase, both in tenacity and in elastic limit, is seen as the proportion of carbon is increased. The modulus of elasticity varies irregularly within a moderate range, and is evidently not affected by the proportion of carbon present. The quality of the metal is usually determined principally by the proportion of carbon, but is also affected, to a considerable extent, by the silicon and manganese, as well as by phosphorus.

The considerable variation here exhibited is partly due to the fact that these steels were supplied by several makers, who presumably used iron from different ores and adopted different mixtures in the crucible, and partly due to the varying hardness produced by accidental variation in rate of cooling, when delivered hot from the rolls.

The strength of good specimens of these metals, as they came from the mill, has been found by the Author to be, as a minimum, about

$$\left. \begin{aligned} T &= 60,000 + 70,000 C \\ T_m &= 4,218 + 4,921 C \end{aligned} \right\} \dots \dots (21)$$

where T is the tenacity in pounds per square inch, and T_m in kilogrammes on the square centimetre; * C is the percentage of carbon. For annealed samples † of good ingot iron and steel,

$$\left. \begin{aligned} T &= 50,000 + 60,000 C \\ T_m &= 3,515 + 4,218 C \end{aligned} \right\} \dots \dots (22)$$

Thus, as illustrating these cases, the Author has found the following figures by test :

* *Trans. Amer. Soc. C. E.*, 1874. (See Appendix.)

† *Structures in Iron and Steel*; Weyrauch, translated by Dubois: N. Y., 1877.

TABLE LXVII.
TENACITY OF STEEL.

CARBON.	TENACITY. <i>T</i>			
	By Test.		By Calculation.	
Per cent.	Lbs. per square inch.	Kilogrammes per square centimetre.	Lbs. per square inch.	Kilogrammes per square centimetre.
0.53	79,062	5,558	81,740	5,746
0.65	93,404	6,566	88,940	6,153
0.80	99,538	6,997	98,060	6,893
0.87	106,979	7,520	102,020	7,171
1.01	109,209	7,677	110,300	7,754
1.09	116,394	8,183	113,480	7,978

The elastic limits, for all common grades, are not far from 0.6 the ultimate.

Bauschinger, experimenting upon Ternitz Bessemer steel, deduced the following :

$$\left. \begin{aligned} T_m &= 4,350 (1 + C^2) \\ i. e. T &= 61,870 (1 + C^2) \end{aligned} \right\} \dots \dots \dots (23)$$

which equation expresses the results of his tests with great accuracy.* American steels are seen to be slightly stronger than the European.

Weyrauch gives as a minimum set of values, such as may be used as a basis for specifications :

$$\left. \begin{aligned} T_m &= 3,700 (1 + C) \\ i. e., T &= 52,625 (1 + C) \end{aligned} \right\} \dots \dots \dots (24)$$

which formula is probably also sufficiently exact as expressing the strength of good, pure iron and steel containing no appreciable quantity of the hardening elements other than carbon. For $C = 0$, $T = 52,625$ pounds per square inch

* "Versuche ueber die Festigkeit des Bessemerstahls," etc.

(3,700 kilogrammes per square centimetre), which is a usual figure for good bridge, cable, and blacksmith's iron of about 2 inches (5.08 centimetres) diameter.

235. As a general rule, the Elongations of Steel of the finest grades are diminished as the tenacity increases, and in steels tested for Trautwine* this reduction is nearly proportional to the increase in strength. Calling the shock-resisting power of the piece—or, more correctly, its work of resistance—equal to two-thirds the product of the ultimate resistance by the total elongation, its *total resilience*, R , we get

$$\left. \begin{aligned} R &= \frac{2}{3} T \times El = 4,000 \text{ foot-pounds nearly} \\ R_m &= \frac{2}{3} T_m \times El_m = 2.81 \text{ kilogrammetres} \end{aligned} \right\} \quad (25)$$

the first value being that for one square inch sectional area and one foot in length, the latter for one square centimetre area of cross-section and one centimetre in length. Then we have from the above :

$$\left. \begin{aligned} El &= \frac{6,000}{T} \\ El_m &= \frac{4.2}{T_m} \end{aligned} \right\} \dots \dots \dots (26)$$

for the elongation per inch or centimetre at the point of rupture.

This extension varies in crucible steels containing, as in the above examples, the usual proportion of manganese, from 10 per cent. at the lower limit to $\frac{1}{2}$ per cent. at the higher. When care is taken to secure freedom from those elements which produce cold-shortness, higher values of elongation and resilience may be secured.

Makers of open-hearth steel have thus often been able to guarantee a tenacity of 80,000 pounds per square inch (5,624 kilogrammes per square centimetre), with an elongation of 20 per cent. and an elastic resistance of 50 per cent. of the

* Civil Engineer's Pocket Book.

NICKEL STEEL: ORDNANCE BUREAU, U. S. N. (Page 431.)

No. 4,816.

Marks, U. S. N. 1.
Diameter, ".564.

Sectional area, .25 square inch.
Gauged length, 3".

Applied Loads.		Elongation per Inch.	Successive Elongation per Inch.	Permanent Set.	Successive Permanent Set.	Remarks.	
Total.	Per Square Inch.						
Pounds.	Pounds.	Inch.	Inch.	Inch.	Inch.		
250	1,000	0.	0.	0.	0.	Initial load.	
1,250	5,000	.000100	.000100	0.	0.		
2,500	10,000	.000333	.000233	0.	0.		
5,000	20,000	.000767	.000434	0.	0.		
6,250	25,000	.001000	.000533	0.	0.		
7,500	30,000	.001267	.000633	0.	0.		
8,750	35,000	.001433	.000766	0.	0.		
9,500	38,000	.001633	.000900	0.	0.		
10,000	40,000	.001700	.001067	0.	0.		
11,250	45,000	.001933	.001233	0.	0.		
12,500	50,000	.002100	.001467	0.	0.		
13,750	55,000	.002333	.001733	0.	0.		
15,000	60,000	.002600	.002067	0.	0.		
16,250	65,000	.002733	.002433	0.	0.		
17,500	70,000	.003000	.002867	.000033	.000033		
18,750	75,000	.003300	.003300	.000033	0.		
20,000	80,000	.003600	.003800	.000100	.000067		
21,000	84,000	.003733	.004233	0.	0.		
21,250	85,000	.004000	.004767	.000333	.000233		Elastic limit.
22,000	88,000	.004267	.005300	0.	0.		
22,250	89,000	.004333	.005866	0.	0.		
22,500	90,000	.004567	.006434	.000667	.000334		
22,750	91,000	.004700	.007000	0.	0.		
23,000	92,000	.004900	.007600	0.	0.		
23,250	93,000	.005000	.008100	0.	0.		
23,500	94,000	.005300	.008700	0.	0.		
23,750	95,000	.005400	.009300	0.	0.		
24,000	96,000	.005733	.009933	0.	0.		
24,250	97,000	.006000	.010667	0.	0.		
24,500	98,000	.006500	.011500	0.	0.		
24,750	99,000	.006867	.012467	0.	0.		
25,000	100,000	.007400	.013533	0.	0.		
26,000	104,000	.0133	.0159	0.	0.		
27,000	108,000	.0233	.0180	0.	0.		
28,000	112,000	.0400	.0217	0.	0.		
29,000	116,000	.0600	.0260	0.	0.		
30,000	120,000	.0800	.0300	0.	0.		
31,000	124,000	.1067	.0367	0.	0.		
32,000	128,000	.1733	.0666	0.	0.		
32,710	130,840					Tensile strength.	

GENERAL SUMMARY.

Specific gravity	8.0683
Hardness	31.30
Tensile strength per square inch of original section	130,840 pounds
Elastic limit per square inch of original section	84,000 pounds
Elongation per inch after rupture	.2533 inch
Elongation per inch under strain at elastic limit	.003733 inch
Reduction in diameter at point of rupture	.184 inch
Reduction in area after rupture, per cent. of original section	54.6
Position of rupture	.74" from neck
Character of broken surface	fine silky; cup-shaped ends; serrated radial lines
Elongation of inch sections	.12", .19", .45"

CHEMICAL COMPOSITION.

	Per Cent.
Carbon	0.531
Manganese	0.873
Silicon	0.370
Sulphur	0.202
Phosphorus	0.026
Nickel	30.970

ultimate. The total resilience of such metal is, therefore, about $\frac{2}{3} \times 80,000 \times .20 = 10,667$ foot-pounds per inch of section and foot of length, nearly 7.5 kilogrammetres for samples one square centimetre in section and a centimetre in length. At the elastic limit, the *elastic resilience* may be taken at about

$$R_e = \frac{1}{2} T_e \times El,$$

one-half the product of the elastic resistance by the elongation. This elongation is usually not far from one-tenth per cent., and the elastic limit rises from two-fifths in soft irons to nearly the ultimate resistance in hardened steel; for tool steels it may be taken at two-thirds, and for the softer grades usually at one-half.

By reducing the carbon and adding manganese some extraordinary metals are obtained. A "steel" containing 0.10 per cent. carbon and 0.45 per cent. manganese, has exhibited a tenacity of 90,000 pounds per square inch (6,327 kilogrammes per square centimetre) and an extension of 25 per cent.

The Elongation of Steel Bars may be reckoned at about three-fourths that of iron up to the elastic limit.

236. Boiler and Bridge Plate Steels, made by the pneumatic and open-hearth processes, have nearly the same strength as bars made by the same methods. The following are figures obtained by Hill* for open-hearth steel:

TABLE LXVIII.

TENACITY OF O. H. BRIDGE PLATE—FRACTURED LENGTHWISE.

CARBON.	RESISTANCE ELASTIC.		RESISTANCE ULTIMATE. <i>T</i>		ELONGATION.
	Pounds per square inch.	Kilogrammes per square centimetre.	Pounds per square inch.	Kilogrammes per square centimetre.	
0.30	49,353	3,469	93,339	6,561	.16
0.40	63,227	4,444	86,410	6,074	.14
0.50	65,070	4,574	83,190	5,823	.10

* *Trans. Eng'rs. Soc. of West. Pennsylvania*, 1880.

TABLE LXIX.

TENACITY OF O. H. BRIDGE PLATE—FRACTURED CROSSWISE.

CARBON.	RESISTANCE, ELASTIC.		RESISTANCE, ULTIMATE. <i>T</i>		ELONGATION.
	Pounds per square inch.	Kilogrammes per square centimetre.	Pounds per square inch.	Kilogrammes per square centimetre.	
0.30	49,510	3,480	95,453	6,710	.18
0.40	63,723	4,480	87,780	6,171	.16
0.50	65,300	4,580	84,995	5,975	.15

Boiler and bridge plates are usually strongest in the direction of the length of the sheet. Uniformity of strength may be secured by rolling equally in both directions from a pile having nearly the shape of the finished sheet. The more thoroughly the metal is worked in the process of manufacture, the better its quality; this remark is especially true of cold-short iron and steel.

Welded bars show that while steel can be perfectly welded, there is often a loss of nearly 30 per cent. of ultimate strength, as compared with the original bar; moreover, the elastic limit is too near the ultimate strength, and the percentage of elongation too small to give sufficient warning of impending failure. It will, therefore, be safe to conclude that welded members in steel construction, while no worse than welded iron ones, are not desirable, and, in fact, ought not to be admitted at all, except where the grade of steel used is very low, and then the greatest caution in working and annealing will be required.

Rails made either of iron or of soft steel exhibit about the same tenacity as heavy plate. It is found advisable to secure such small proportions of the hardening elements that the tenacity shall not exceed 65,000 to 70,000 pounds to the square inch (4,581 to 4,921 kilogrammes per square centimetre), and that an elongation of at least 20 per cent. shall be obtained. Such rails have the composition indicated in Articles 80, 237.

237. **Tenacity of Rail Steel.**—The following are data obtained by Dr. Dudley from rails in use on the Pennsylvania Railway,* the average of several samples being taken :

TABLE LXX.
TENACITY OF RAILS.

GRADE.	TENACITY. <i>T</i>		ELONGATION.	COMPOSITION.				
	Pounds per square inch.	Kilogrammes per square centimetre.		Carbon.	Phosphorus.	Silicon.	Manganese.	Phosphorus.
			Per cent.	Per ct.	Per ct.	Per ct.	Per ct.	Units.
<i>a</i>	79,625	5,597	19.6	.324	.076	.102	.562	34.8
<i>b</i>	81,250	5,732	15.6	.379	.095	.051	.669	37.9
<i>c</i>	72,750	5,114	22.5	.308	.054	.045	.439	26.7
<i>d</i>	76,750	5,396	11.5	.438	.127	.031	.656	42.0
<i>e</i>	75,125	5,325	17.1	.334	.077	.060	.491	31.3
<i>f</i>	80,188	5,637	14.2	.390	.106	.047	.647	38.9

Of these samples, *a* and *b* wore respectively well and badly on a straight line; *c* and *d* behaved similarly different on curves; *e* and *f* represent averages of good and of bad wear under all conditions noted, and each is an average of 32 samples. The hardest rails had greater tenacity and yet less endurance than the softer and tougher specimens.

The resistance of ingot iron, or mild steel plate (of class *a*, last table, Art. 180), to "bulging stress," was found by Kirkaldy in the following manner: Disks one foot (0.305 metre) in diameter were forced, by a hemispherical-ended bar turned to a radius of five inches, through circular openings 10 inches (0.254 metre) in diameter, and the resistance noted thus:

THICKNESS.	$\frac{5}{8}$	$\frac{1}{2}$	$\frac{3}{8}$	$\frac{1}{4}$	$\frac{1}{8}$
Unannealed pounds..	215,685	162,735	104,846	71,800	35,397
Annealed pounds..	198,005	154,230	95,605	59,425	25,435
Unannealed kilogrammes..	97,815	73,817	47,558	32,568	16,056
Annealed kilogrammes..	89,815	69,859	43,366	26,955	11,437

* *Trans. Amer. Inst. Mining Engineers*, 1881.

Every sample tested came out uninjured by either cracking or lamination. The figures given are the averages given by twenty specimens, of which ten were annealed before test.

238. Tenacity of Steel Boiler Plate.—Several "steels," made as described at the close of Art. 157, were tested by Kirkaldy in the form of boiler plate (class *a*), and the following figures were obtained by that author as the data so derived:

TABLE LXXI.

SWEDISH BOILER PLATES UNDER TENSION.

DESCRIPTION.	MARKED.	TEST-NUMBER	ORIGINAL SIZE.		ORIGINAL AREA.	ELASTIC STRESS PER SQUARE INCH.		ULTIMATE STRESS PER SQUARE INCH.		RATIO OF ELASTIC TO ULTIMATE.	CONTRACTION OF AREA AT FRACTURE.		EXTENSIONS, SETS AT	APPEARANCE OF FRACTURE.
			<i>H.</i>	<i>Inches.</i>		<i>Sq. in.</i>	<i>Lbs.</i>	<i>Lbs.</i>	<i>P. c.</i>		<i>P. c.</i>	<i>P. c.</i>		
Unannealed.	No. 1.	1,006	0.95 × .129	1.283	53,300	74,915	71.1	43.1	0.00	10.8	100	per cent. silky.		
	1.	1,012	0.95 × .250	2.487	37,900	60,480	62.7	48.5	0.22	28.2	Do.	Do.		
	1.	1,018	0.95 × .380	3.781	20,500	51,456	57.3	59.3	7.33	36.1	Do.	Do.		
	1.	1,024	0.95 × .495	4.025	31,100	55,803	55.7	50.0	5.82	36.4	Do.	Do.		
	1.	1,030	0.95 × .625	6.218	28,000	52,924	52.9	55.1	6.66	37.2	Do.	Do.		
Annealed.	2.	1,909	0.95 × .124	1.233	35,500	57,485	61.8	57.1	1.11	22.9	Do.	Do.		
	2.	1,915	0.95 × .255	2.537	33,800	54,543	62.6	60.9	3.90	33.8	Do.	Do.		
	2.	1,921	0.95 × .380	3.781	38,900	51,076	56.0	63.4	7.39	35.8	Do.	Do.		
	2.	1,907	0.95 × .490	4.875	27,800	51,338	54.2	61.0	8.70	38.5	Do.	Do.		
	2.	1,933	0.95 × .628	6.248	25,500	50,432	50.6	62.0	9.98	34.4	Do.	Do.		
Unannealed average.....						35,960	59,116	59.9	51.2	4.01	2.97			
Annealed average.....						30,000	52,975	57.0	60.9	6.22	33.1			

The mean resistance in metric measures is, therefore, for metals of the character and composition of those of which the analysis is given at the head of Art. 227, when annealed, 2,109 kilogrammes per square centimetre of section, and when unannealed, as they come from the plate rolls, 2,528 kilogrammes. The metal is obviously ingot iron.

The characteristics of such metal as is here considered

are best shown by the strain-diagrams exhibited in illustration of Art. 205.

239. Pneumatic and Open-Hearth Steels Compared.—The two last described steel-making processes, the pneumatic and the open-hearth, are sometimes carried on in the same establishment, and thus an opportunity is offered of comparing them directly. This is the case at the Newburgh works.

The following are average results of their work: *

One hundred pounds or kilogrammes of Bessemer pig iron is produced from:

	Lbs. or Kilogs.
Ore, calcined.....	215
Limestone.....	14
Charcoal.....	90
Total.....	319

A similar weight of Bessemer ingots requires:

	Lbs. or Kilogs.
Pig (dark gray).....	108.7
Iron and steel scrap.....	3.7
Ferro-manganese, or spiegeleisen.....	0.8
Total.....	113.2

The same weight of Siemens-Martin ingots demands:

	Lbs. or Kilogs.
Pig (white and mottled).....	30.7
Scrap.....	71.0
Ferro-manganese, or spiegeleisen.....	2.8
Total.....	104.5
Mill cinder.....	1.5
Coal.....	75.0

An equal weight of refined Bessemer steel requires:

	Lbs. or Kilogs.
Steel from converter.....	95.0
Scrap.....	4.3
Ferro-manganese or spiegeleisen.....	5.7
Total.....	105.0
Coal.....	43.0

* *Engineering*, Oct. 6, 1882, p. 325.

The steels produced have the following composition :

	BESSEMER.			OPEN-HEARTH.		
	Hard.	Medium.	Soft.	Hard.	Medium.	Soft.
Carbon	0.638	0.368	0.126	0.687	0.303	0.167
Silicon	0.464	0.172	0.135	0.046	0.010	0.023
Sulphur	0.009	0.015	0.014	0.008	0.006	0.013
Phosphorus	0.042	0.044	0.060	0.036	0.045	0.062
Manganese.....	0.640	0.417	0.158	0.404	0.290	0.044
Cobalt (traces of nickel).	0.640	0.020	0.030
Copper.....	0.100	0.037	0.112	0.119	0.075	0.076
Iron (by difference).....	98.127	98.927	99.395	98.700	99.241	99.615

These steels, when tested by tension, gave the results recorded in the following table :

MATERIAL.	TENACITY. <i>T</i>		EXTENSION.	REDUCTION OF AREA.
	Lbs. per sq. in.	Kilogs. per sq. cm.		
Hard ingot ; refined Bessemer steel.....	135,072	9496.5	Per cent. 15.8	Per cent. 22.0
Refined steel.....	106,624	7475.7	20.0	28.7
Medium Bessemer axle	95,872	6711.8	21.0	29.4
“ “ tire.....	74,144	5412.5	32.0	51.4
Soft Bessemer plate	78,624	5527.2	25.5	48.7
Soft ingot iron, or Bessemer tire.....	73,920	5196.5	23.6	59.0
Soft ingot iron ; Siemens-Martin plate...	68,688	4828.8	32.2	66.1
Heavy refined iron plate.....	53,984	3795.1	23.0	32.1
“ “	51,276	3776.0	27.9	31.3

240. **Tenacity of Steel Wire.**—Wire cannot be made from hard steels, but the softer grades often make excellent wire. The same variation in strength occurs with variation in size that was noted in the case of iron wire. Records taken from reports of tests of wire for the East River bridge at New York, were furnished the Author by the engineers in

charge of the work. This wire was supplied under specifications calling for No. 8 wire (0.165 inch, 0.42 centimetre in diameter) to weigh 0.715 pound per foot in length (1.1 kilogrammes per metre), to break under a load not less than 3,400 pounds (15.45 kilogrammes), equivalent to 160,000 pounds per square inch of section (11,250 kilogrammes per square centimetre), to have an elastic limit of 0.47 the breaking load, and a modulus of elasticity of 27,000,000 to 29,000,000 (or 14,552,100,000 to 14,692,700,000 in metric measures). The crucible steel supplied for test exhibited tenacities varying from 125,000 to 200,000 pounds per square inch (8,787 to 14,060 kilogrammes per square centimetre), stretching from 7 to 21 per cent., and giving moduli of elasticity varying from twenty-eight to thirty-one millions, and usually about twenty-nine millions.

The "Bessemer steel" wires sustained 150,000 to 178,000 pounds per square inch (10,535 to 12,513 kilogrammes per square centimetre), elongated 4 to 2 per cent., and gave nearly the same moduli of elasticity. "Open-hearth" steel wire ranged in tenacity from 175,000 to 182,000 pounds per square inch (12,300 to 12,975 kilogrammes per square centimetre), and stretched 42 to 22 per cent.; the modulus of elasticity was as above. All three methods of manufacture were evidently capable of producing satisfactory wire.

Crucible steel wire has been made, according to Roebling, of a tenacity of 300,000 pounds per square inch (21,090 kilogrammes per square centimetre).

Steel-wire rope is used for rigging and for cables and hawsers, and is stated to have three times the strength of hempen rope of similar size. Tests were made at the Portsmouth dockyard. The sizes tested were, respectively, 7 inches, 6 inches, and 5½ inches (17.78, 15.24, and 14.01 centimetres) in circumference, and were guaranteed to have a breaking strain of 110 tons, 80 tons, and 67 tons (111,765, 81,280, 68,076 kilogrammes) respectively. They broke at 118 tons, 92 tons, and 75 tons (120,000, 93,560, 76,272 kilogrammes), in each case considerably higher than the guaranteed stress, although the ropes actually tested were picked out at random. The core

of each rope is formed of tarred hemp, over which are twisted the strands of wire.

The variations in strength noted above for different sizes of iron are not as considerable in the soft steels and ingot irons, but they become even more observable in the harder grades, and are too variable to be expressed with useful approximation by any formula. Hard steels are rarely made in large pieces where their use is avoidable.

241. The Tenacity of Special Steels is reported as very high. Samples of Chrome Steel tested at West Point foundry gave results as stated below. Twelve samples cut from Nos. 1, 2, and 3 octagon tool-steel, $1\frac{3}{4}$ inches (4.44 centimetres) in diameter being tested, one half as furnished, one half (mark H) after heating them.

TABLE LXXII.
TENACITY OF CHROME STEEL.

	DENSITY.	TENACITY. <i>T'</i>	
		Lbs. per sq. in.	Kgs. per sq. cm.
Bar No. 1	7.8464	181,830	12,783
“ 1	7.8450	179,020	12,584
“ 2	7.8339	176,920	12,437
“ 2	7.8511	198,910	13,983
“ 3	7.8161	173,770	12,409
“ 3	7.8556	163,760	11,502
“ 1 H.	7.8373	183,620	12,908
“ 1 H.	7.8488	174,750	12,284
“ 2 H.	7.8386	168,530	11,856
“ 2 H.	7.8401	193,210	13,582
“ 3 H.	7.8229	174,540	12,270
“ 3 H.	7.8194	190,910	13,418
Average	179,980	12,652

The Author has found this steel more ductile than carbon steel. The figures are high, but not higher than have been given by carbon steel.

No. 8 chrome steel wire tested by the New York and Brooklyn Bridge Company, sustained about the same stress as carbon steel.

Tungsten Steel tested by Styffe, having the composition, C., 0.0052; Si., 0.0004; Tungsten, 0.003; P., 0.0004; S., 0.00005, broke at about 160,000 pounds per square inch (11,248 kilogrammes per square centimetre), elongating 13 per cent., with a reduction of section of 46 per cent.

The following table shows the average physical qualities that should be obtained in forgings made of the several grades of steel mentioned, the test specimens being 2 inches long between measuring points and $\frac{1}{2}$ inch in diameter and cut from full-sized prolongations of the forgings after treatment; the elastic limit being determined not by the drop of the beam, but by an electric micrometer:

	Tensile strength.	Elastic limit.	Extension percentage.	Contraction percentage.
<i>Simple Steel.</i>				
(1) Annealed	58,000	28,000	28	55
(2) "	80,000	37,000	23	45
(3) Oil-tempered, with axial hole	80,000	45,000	25	50
<i>Nickel Steel.</i>				
(4) Annealed.....	80,000	45,000	23	45
(5) Oil-tempered, with axial hole	80,000	50,000	25	50
(6) " " " "	90,000	60,000	22	50

"*Manganese Steels*," containing considerable percentages of manganese, have been made, by Hadfield, particularly, which have been found to be of great value for structural work. Between 2.50 and 7 per cent. Mn. makes steel brittle; but, from the latter limit to 20 per cent., the alloy exhibited exceptionally excellent qualities; having sometimes double the tenacity of carbon steels of equal ductility. Nickel steels are finding extensive use in marine engineering. (Appendix.)

242. "**Steel Castings**" are often so variable in composition and structure as to be safe only when used with a very considerable factor of safety. When well made, however, they are found valuable as a substitute for cast iron or bronze, as they possess the strength of the best bronze, and cost far

less; while their superior strength makes them more desirable, in many cases than cast iron, notwithstanding their greater cost. The best "steel castings" have the strength of good forgings, and are therefore used where forgings would be either very difficult to make, or would be too expensive. They should contain less than one-half per cent. of silicon or of carbon, if sound castings can be secured, and should contain as little manganese as is necessary to give them soundness.

The following are data derived from tests* of well annealed steel castings of known composition:

TABLE LXXIII.
TENACITY OF STEEL CASTINGS.

CHEMICAL COMPOSITION.			TENACITY. <i>T</i>		FINAL ELONGATION.
			Pounds per square inch.	Kilogrammes per square centimetre.	
C.	Si.	Mn.			Per cent.
.26	.26	.41	68,096	4,787	27.5
.30	.22	.63	69,440	4,882	24.0
.35	.23	.61	80,640	5,667	21.5
.425	.27	.75	105,036	7,384	13.1
.50	.40	.66	101,248	7,118	5.0
.55	.40	1.00	103,712	7,291	9.8
.77	.46	.67	75,262	5,291	1.5
.96	.62	.64	85,792	6,031	1.0

It is important that all such castings should be annealed, as otherwise serious loss of strength may be incurred. Steel castings made by the open-hearth method may be obtained of any desired composition, from a minimum of one-fourth or one-third per cent. in the hardening elements. They are used for gearing, axle-boxes, cross-heads, and such other forms as cannot be cheaply made of wrought iron. Their malleability is an important quality, not simply because of the toughness of the casting and its greater safety where shocks are to be met, but also as permitting change of shape

* *Iron*, 1880.

by forging when, as is sometimes the case, it becomes desirable so to alter them.

243. Steels for Tools were tested by Chief Engineer David Smith, U. S. N., chairman of a committee of the U. S. Board appointed to test metals, and the results are here given as reported by that committee.

The steels were obtained from both American and English makers, and had the composition, as determined by Mr. A. A. Blair, shown in the table on the next page.

Their specific gravities were found to vary somewhat, thus :

TABLE LXXIV.
SPECIFIC GRAVITIES OF TOOL STEELS.

STEEL.	$2\frac{1}{2}'' \times 1\frac{3}{4}''$	$2'' \times 1\frac{1}{4}''$	ROUND.	OCTAGON.	MEAN.
A	7.8124	7.7998	7.7873	7.8232	7.8132
B.....	7.8022	7.7943	7.8090	7.8161	7.8054
C.....	7.7979	7.7995	7.8087	7.8173	7.8058
D	7.7293	7.7473	7.8155	7.8028	7.7737
E.....	7.8000	7.8040	7.8044	7.8036	7.8030
F.....	7.8081	7.8012	7.8032	7.8132	7.8065
G.....	7.8042	7.8117	7.8148	7.8153	7.8113
H.....	7.7976	7.8010	7.8119	7.8093	7.8050
I.....	7.8163	7.8063	7.8158	7.8107	7.8123
J.....	7.8158	7.7930	7.8179	7.8205	7.8118
K.....	7.8122	7.7957	7.7372	7.8123	7.7894
L.....	7.7831	7.7952	7.8098	7.8177	7.8015
M.....	7.8308	7.8174	7.8054	7.8279	7.8204
N.....	7.7769	7.7880	7.8138	7.8249	7.8009
O	7.8313	7.8004	7.8232	7.8406	7.8239
P	7.7818	7.7776	7.8169	7.8170	7.7733
Q.....	7.8201	7.8177	7.8248	7.8127	7.8188

Method of Test.—The tools were used in turning, planing, slotting, chipping and drilling.

Before beginning the regular tests of the tools of the different steels, preliminary tests of six hours each were made, using similar tools belonging to the shop, in order to determine the speed, depth of cut, feed, etc., that were best adapted to the material operated upon.

The machines to be used in making the tests were then

TABLE LXXV.—CHEMICAL ANALYSES OF TOOL STEELS.

STEEL.	LABORATORY NUMBER.	CROSS-SECTION OF BAR.	PERCENTAGE OF—											
			Sulphur.	Phosphorus.	Silicon.	Total carbon.	Graphite.	Combined carbon.	Manganese.	Copper.	Cobalt.	Nickel.	Chromium.	Aluminum.
A	67	2 1/2" x 1 1/2"	trace	0.029	0.164	0.804	0.031	0.773	0.201	0.007	none	trace	none	0.032
A	89	Octagon	trace	{ 0.041 0.040	{ 0.136 0.129	0.953	0.043	0.920	0.226	0.007	trace	none	none
B	79	2" x 1 1/2"	trace	0.026	0.208	1.090	0.024	1.066	0.177	0.003	none	none	
B	88	Round	trace	0.020	0.177	1.057	0.023	1.054	0.135	0.003	none	none	
C	66	1 1/2" x 1 1/2"	0.002	0.027	0.142	1.049	0.031	1.054	0.130	0.003	trace	none	
C	66	Round	0.003	0.025	0.145	1.047	0.045	1.132	0.120	0.007	trace	none	
D	65	2" x 1 1/2"	0.003	0.027	0.306	1.345	0.207	1.138	0.245	0.017	trace	none	0.023	
E	86	2 1/2" x 1 1/2"	0.003	0.030	0.281	1.375	0.028	0.787	0.345	0.012	trace	none	0.022	
E	87	Round	0.008	0.028	0.261	0.705	0.027	0.766	0.372	0.017	trace	none	
E	64	Octagon	0.003	0.047	0.275	1.030	0.029	1.001	0.359	0.023	trace	none	0.024	
F	101	2 1/2" x 1 1/2"	trace	0.068	0.144	1.009	0.020	0.989	0.032	0.007	trace	0.433	
F	62	2" x 1 1/2"	0.005	0.021	0.129	0.825	0.014	0.811	0.245	0.007	trace	{ 0.551 0.636	0.034	
F	63	Octagon	trace	0.020	0.189	0.935	0.015	0.920	0.062	0.010	trace	{ 0.223 0.212	0.029	
G	99	Round	0.001	0.023	0.093	0.866	0.011	0.840	0.223	0.007	0.006	0.379	
H	80	2 1/2" x 1 1/2"	trace	0.023	0.319	1.034	0.028	1.026	0.343	0.003	trace	none	
H	11	2 1/2" x 1 1/2"	trace	0.041	0.189	1.176	0.033	1.143	0.177	0.005	trace	0.021	
I	11	Octagon	0.001	0.029	0.184	1.029	0.019	1.010	0.174	0.005	trace	0.010	
J	96	2" x 1 1/2"	trace	0.024	0.287	0.922	0.022	0.970	0.381	0.007	trace	none	
K	85	2" x 1 1/2"	trace	0.026	0.206	1.082	0.028	1.054	0.058	0.003	none	none	
K	77	Round	trace	0.025	0.231	1.111	0.029	1.082	0.050	0.002	trace	none	
L	98	2" x 1 1/2"	0.002	0.018	0.103	1.106	0.026	1.080	0.157	0.005	none	none	
L	76	Octagon	trace	0.019	0.248	1.083	0.021	1.062	0.149	0.002	trace	none	
M	89	2 1/2" x 1 1/2"	0.003	0.020	0.109	0.892	0.012	0.880	0.200	0.005	trace	none	
M	81	Round	trace	0.025	0.085	1.232	0.021	1.211	0.116	0.003	trace	none	0.022	
N	93	Octagon	0.002	0.027	0.070	1.005	0.029	0.977	0.098	0.013	trace	none	
N	94	2" x 1 1/2"	0.002	0.005	0.095	1.455	0.044	1.411	0.122	0.010	none	none	
N	93	Round	0.003	0.003	0.134	1.261	0.015	1.246	0.097	0.003	none	none	
O	70	2" x 1 1/2"	0.001	0.014	0.069	1.347	0.022	1.325	0.050	0.010	trace	none	
O	68	Round	trace	0.008	0.109	1.036	0.010	1.017	0.065	0.003	none	none	
P	72	2 1/2" x 1 1/2"	trace	0.005	1.279	1.199	0.013	1.186	0.039	0.005	0.018	{ 0.916 0.899	0.026	
P	100	Round	trace	0.023	0.167	0.877	0.033	0.844	0.017	none	trace	none	
O	95	2" x 1 1/2"	trace	0.026	0.116	1.116	0.034	1.082	0.044	0.007	trace	0.442	
O	91	Octagon	0.001	0.047	0.097	1.068	0.021	1.030	0.130	0.003	0.011	none	
O	82	1 1/2" x 1 1/2"	trace	0.027	0.177	1.068	0.010	1.049	0.055	0.007	trace	none	
* Q	96	1 1/2" x 1 1/2"	trace	0.027	0.226	1.065	0.027	1.038	0.066	0.007	trace	none	

adjusted in accordance with the determinations thus found, and remained under the same conditions throughout the experiments.

The length of the roll required to test one steel was found to be $7\frac{1}{2}$ inches, the width of plate in planing 5 inches, and the length of plate in slotting 7 inches, and these dimensions were adopted and followed as nearly as possible in making the tests of the steels.

The face of the plate operated upon in making all the tests in which they were used, was that which was downward in casting, and $30\frac{1}{4}$ inches long by $10\frac{1}{4}$ inches wide; the former being the length of the cut in planing, and the latter the length of the cut in the slotting tests.

Each tool (with the exception of chisels) was first weighed before securing it in position for the required work, and then used as long as it would hold its cut, when it was removed and made ready for use again. The cuttings were then weighed and the weight noted. The same was repeated with each and every tool tested.

With few exceptions the tools of each steel were used successively in their numerical order, until all had been used, when the same order was again followed and repeated with tools as often as required during the six hours devoted to each of the tests. At the close of each test the tools were again weighed, in order to determine the loss or waste of the steel due to dressing the tools. The cuttings were again weighed in the aggregate to serve as a check on the separate weights; but in no instance was there found any appreciable difference between the aggregate weight and the sum of the weights cut by each of the tools.

Results of Tests.—The following table presents a summary of the results obtained, with the relative standing of each steel, and the test of the cast iron worked by all the tools. These quantities are peculiarly valuable as presenting for the first time a set of results of tests of this character, in which the chemical and physical qualities of the metal were simultaneously determined.

TABLE LXXVI.—SUMMARY OF TESTS OF TOOL STEELS.

STEEL.	WEIGHT CUT PER TOOL, IN POUNDS.				CHIPPING, SQUARE INCHES ● CUT PER TOOL.	RELATIVE VALUES.						TEAR-SPON. $\frac{1}{2}$	COM- PRES- SION. C	TORSION.			MEAN SPECIFIC GRAVITY.
	Turning.	Planing.	Slotting.	Drilling.		Turning.	Planing.	Slotting.	Drilling.	Chipping.	Total.			Breaking weight per square inch	Weight per square inch at first per- ceptible com- pression.	Proof-stress, in foot- pounds.	
A	7.5635	8.3887	1.2615	2.5693	3.56	1.819	5.133	3.415	4.387	1.479	4.020	108.194	44.162	95.50	297.34	7.8132	
B	17.0463	8.0951	2.3082	4.3800	0.166	4.315	4.953	6.649	7.478	3.809	6.638	100.075	47.567	95.60	287.86	7.8054	
C	14.8625	7.5974	3.2884	3.3779	4.76	3.573	4.066	8.902	4.066	1.078	7.925	92.524	43.393	105.25	270.20	7.8056	
D	21.5513	10.9897	3.5150	3.1030	5.768	5.181	6.724	9.516	5.928	2.397	7.911	112.704	44.737	100.59	284.20	7.7737	
E	26.1432	8.4000	1.6080	3.3270	1.741	6.286	5.139	4.353	5.680	0.723	5.493	111.457	42.013	105.64	320.09	7.8065	
F	20.8476	11.5835	3.1444	3.1000	24.063	5.012	7.087	8.512	5.293	1.0000	8.892	104.756	42.013	105.64	318.11	7.8065	
G	28.2071	9.7155	2.5139	3.1660	5.625	6.781	5.944	4.808	4.808	2.138	6.618	110.572	48.652	125.51	300.38	7.8113	
H	20.0742	13.7385	2.4370	3.8200	5.596	4.826	8.406	6.597	6.522	2.326	7.102	114.335	44.473	111.87	292.58	7.8155	
I	15.0859	8.3400	0.9550	3.4500	0.255	3.627	5.103	5.568	5.800	3.846	5.952	106.453	45.773	90.65	280.87	7.8155	
J	32.5352	8.4795	3.6930	3.8000	7.708	6.181	5.188	6.821	6.821	3.903	8.899	109.440	42.098	102.37	316.03	7.8155	
K	25.7102	10.1665	2.7830	3.1230	4.688	6.181	6.221	7.930	1.948	1.948	7.173	91.025	40.343	102.92	292.74	7.8094	
L	21.0522	7.0920	2.0300	2.8500	8.938	5.060	4.872	5.495	4.866	2.052	5.534	95.414	48.061	99.71	278.81	7.8015	
M	16.0227	5.8800	1.2367	4.3500	8.707	3.985	3.580	3.348	3.348	3.919	5.591	99.330	43.263	99.86	288.81	7.8004	
N	13.4738	10.0880	1.5	3.8500	11.5	3.239	6.176	5.794	1.0000	4.779	7.426	91.945	42.330	103.59	268.02	7.8009	
O	15.6031	9.7340	2.3845	4.3700	6.688	3.751	5.956	6.855	7.641	4.779	6.839	115.922	41.054	90.10	272.08	7.8839	
P	41.5944	10.3435	2.0412	3.6090	8.769	1.0000	1.0000	7.150	9.577	3.352	1.0000	115.922	40.358	103.55	322.78	7.7733	
Q	9.6141	6.7090	1.2489	2.7120	8.025	2.311	4.105	3.381	4.630	3.364	4.400	99.614	43.258	98.95	288.61	7.8188	
Q*	12.8343	7.8053	

* Contributed by maker. † English Steel. ‡ Special bars. § Including actual work done by chisels partially worn.

CAST IRON.

TENSION, IN POUNDS.	COMPRESSION, IN POUNDS.		TORSION. SAMPLE $\frac{3}{4}$ " x $1\frac{1}{2}$ ".		MEAN SPECIFIC GRAVITY.
	Weight per square inch at first perceptible compression.	Crushing weight per square inch.	Proof-stress, in foot-pounds.	Ultimate stress, in foot-pounds.	
24,412	46,202	98,692	60,90	101.77	7.2115
			26,951,080		

Tempering.—In all the tests made by the tools of the different steels, as before remarked, they were tempered at a heat found by trial best adapted to the work, excepting those of *P* and *Q*, which were hardened and tempered under the direction of representatives of the makers. It will be seen, by reference to the records, that the tools of all the other steels, used for turning, planing, slotting, and drilling, were tempered at a pale straw color, excepting those of *H* and *O*, for drilling, which were found to do best when tempered at a deep straw, for no apparent reason unless it be that they were the two easiest steels to work.

In chipping, the chisels were all tempered at a brown to a brownish-purple color, excepting those of *H*, *M*, and *O*, which were found to work best when tempered at a purple color.

Heat of Hardening.—A certain relation exists between the heat of hardening and the work done by the steels. A large majority of the bars which gave higher results than the average in turning, planing, and slotting, hardened at a dull to a low red heat, while those which hardened at a higher heat gave lower results than the average, with the few following exceptions, for certain of the purposes mentioned :

The larger and smaller bars of *C* gave, in slotting, the relative results 6 and 2 respectively, and the large bar of *A*, 5, in planing, and these all hardened at a bright cherry-red heat.

Both bars of *F* hardened at a cherry-red, and gave for the larger, in planing and slotting, 3 and 4 respectively, and for the smaller 4, for the three purposes above named.

In drilling and chipping, the bars that gave results higher than the average, hardened at a dull to a cherry-red heat, and the only exception to this was the octagon bar of *F*, which hardened at a bright cherry-red, and gave the best results in chipping.

The lowest heat at which the bars giving the most favorable results in drilling and chipping would harden, averaged somewhat higher than those giving similar results in turning, planing, and slotting. This may be due, in a majority of instances, to the smaller percentage of combined carbon in the bars used for drills and chisels, as is shown by the table of

chemical analyses; but in the case of the round bars of *B* and *E*, in which the combined carbon, as well as all the other constituent elements are nearly the same as those of the larger bars of their respective lots, the fact of both of the round bars hardening at a higher heat than the larger ones must be attributed to some other cause.

Conclusions from Practical Tests.—The conclusions to be drawn from the results of the foregoing practical tests are given by the Committee as follows:

That there is a marked difference in the cutting qualities or the practical value of steels of different makers.

That the heat of tempering is independent of the quality of the steel.

That the character of the work determines the heat of tempering.

That the quality of a steel cannot be determined by its general appearance, although a fine and uniform grain of a silvery whiteness is an indication of good quality.

That the steels of American make compare very favorably with those of three celebrated English makers, and gave the best results in four out of the five tests made.

And that the steel best adapted to a given purpose is practically the cheapest at almost any price, as it will do better and more work, in a given time, with less power and labor, and with less wear and waste of its own material.

It was further noted that the quality of steel, as far as its cutting power was concerned, could not be predetermined by its general appearance; although a fine, close, and uniform grain of a silvery whiteness is in general an indication of good quality, yet a number of exceptions to the rule will be found by reference to the records. Prominent among these are the results given by the large tools of *F* steel in turning, which were greater than those of *N* and *O*, although the grains of the latter two steels were "fine and uniform," and "very fine and uniform," respectively, while that of *F* was "open, coarse, and irregular."

By comparing the results of the practical tests with the observed facility with which the steels were worked at the

heat given, it is found that those which required the greatest amount of hammering at a high heat to bring them into shape, or are what is termed "hard to work," gave, as a rule, the poorest results. On the other hand, those that were "worked very easily," or nearly the same as iron, although they gave much better results than the former in most cases, still were inferior, in nearly every instance, to others that were "worked easily" or "well" at a red to a bright cherry-red heat. The inferences to be drawn from the results of the tests are that both the *size* of the tool and the amount of hammering or rolling the original bar receives have an appreciable effect on the cutting qualities of a tool.

The effect of hammering was noticeable in giving to the steel the appearance of having a finer, more uniform, and closer grain, and this was more prominently observable in the grain of the fractured points of the larger tools when compared with that of the original bar.

A record of the loss of material due to dressing the tools was kept in the turning, planing, and slotting tests, and the results show, as a general rule, that the poorer the steel the greater is the loss from this cause, and that the relative losses are in the direct ratio of the number of changes of the tools required to be made during the tests.

Mild steel of proper quality can now be cut at the rate of 150 feet a minute, with good tools and lubrication, in automatic machines. "Taylor-White" and air-hardening steels may greatly exceed this figure.

It may be here remarked that when a tool began its work the reading of the dynamometer was a good indication of what it was going to do; if the reading was comparatively low the tool almost invariably gave good results, and the reverse was the case when the reading was high.

The characteristics of a good tool steel are well shown in Fig. 61, illustrating Article 205 on Strain Diagrams. Its high elastic limit indicates its hardness and elasticity, its smooth curve shows homogeneousness, and its great strength is exhibited by the altitude of the curve.

244. The Tenacity of Cast Iron, when the castings are

sound, is principally dependent upon its chemical composition, and can usually be fairly inferred from a study of the chemist's analysis. If a determination of density is also made, the engineer usually need not hesitate to base his acceptance or rejection of the material on the chemist's report. (See Appendix.)

The following data were obtained by Major Wade,* and those in the first lot are *selected* as representing good ordnance iron; the others bad:

TABLE LXXVII.
TENACITY OF CAST IRON.

TENACITY, T		SPECIFIC GRAVITY.	COMPOSITION, PER CENT.					
Lbs. per sq. in.	Kgs. per sq. cm.		Sulph.	Phos.	Carbon.		Silicon.	Manganese.
					Graphite.	Combined.		
Lot I.								
28,631	2,013	7.23	.07	...	2.20	2.40	.72
31,734	2,231	7.25	...	1.09	2.00	2.20	.78	1.50
31,311	2,201	7.21	.02	1.45	2.55	.33
31,734	2,231	7.22	2.20	1.70	.33	1.67
31,029	2,181	7.22	1.80	1.50	1.41
27,362	1,923	7.17	.06	1.90	2.05	1.31
Lot II.								
21,156	1,489	7.24	...	1.23	2.55	1.85	.44	.66
20,874	1,467	7.08	.03	2.45	.85	.65
21,579	1,516	7.08	.05	2.70	.70	.98
18,758	1,418	7.02	.07	2.80	.30	1.17

Wade's experiments were upon iron supplied the United States army for guns, were very numerous, and were exceedingly carefully made.

Classing the guns in the order of their value—1, 2, and 3—the following is the average of all for each class:

* Report on Metals for Cannon.

TABLE LXXXVIII.

MEAN TENACITY OF ORDNANCE CAST IRON.

CLASS.	SPECIFIC GRAVITY.	TENACITY. <i>T</i>		CARBON.	
		Lbs. per sq. in.	Kgs. per sq. cm.	Graphite.	Combined.
1	7.204	28,805	2,025	2.06	1.78
2	7.154	24,767	1,741	2.30	1.46
3	7.087	20,148	1,416	2.83	0.82

The best irons were generally richest in combined carbon and in manganese, and lowest in graphite, silicon, and phosphorus, and in total carbon.

Iron supplied to the United States army must be of uniform tenacity, should have a strength of 25,000 to 30,000 pounds per square inch (1,758 to 2,190 kilogrammes per square centimetre), and a specific gravity of about 7.245. Good gun iron is expected to range from 30,000 to 32,000 pounds per square inch (2,190 to 2,250 kilogrammes per square centimetre). Good car-wheel irons often exhibit nearly the tenacity of gun iron, and sometimes elongate three-fourths of 1 per cent. at fracture. Ordinary irons have a tenacity of about 20,000 pounds (1,406 kilogrammes), and often stretch less than 0.1 per cent. Dark irons, as No. 2, of good makes, have a tenacity equal to about two-thirds that of No. 4 of the same make, a good iron giving, in experiments by the Author,* 20,500 and 34,407 pounds per square inch (1,441 and 2,419 kilogrammes per square centimetre) respectively. These samples passed the elastic limit at 7,333 and 12,000 pounds per square inch (515 and 844 kilogrammes per square centimetre), and their moduli of elasticity were 11½ and 16 millions (nearly) pounds per square inch (8,045 to 11,248 kilogrammes per square centimetre). Their densities were 7.186 and 7.259. The average of a large number of tests of iron of all grades, but usually No. 3 machinery iron, is, in

* Report on Salisbury Irons, *R. R. Gazette*, 1877. Pamphlet, 1878.

tension, 18,800 pounds per square inch, as obtained by the Author, while Hodgkinson quotes, for English cast irons, about 16,000 (1,222 and 1,125 kilogrammes per square centimetre). The following may be taken as figures which should be given by the best sorts of cast irons :

TABLE LXXIX.

TENACITY OF GOOD CAST IRONS.

KIND.	TENACITY. T		SPECIFIC GRAVITY.
	Lbs. per sq. in.	Kgs. per sq. cm.	
Good pig iron.....	20,000	1,406	7.10
Tough cast iron.....	25,000	1,758	7.22
Hard cast iron.....	30,000	2,109	7.28
Good tough gun iron.....	30,000	2,109	7.25

It will usually be found that the best single index of the strength of cast iron is its density ; and the best machinery and good gun irons should, in small castings, have a tenacity of about

$$\left. \begin{aligned} T &= 25,000(D - 7) + 20,000 \\ T_m &= 1,758(D - 7) + 1,406 \end{aligned} \right\} \dots (27)$$

between the limits of density, $D = 7$; $D = 7.28$.

In heavy masses the strength of cast iron may be very seriously reduced, and usually is diminished appreciably, by the internal strains due to shrinkage, and by lessened specific gravity. Even in such small variations of section as Hodgkinson experimented upon—1, 2, and 3-inch sections—this loss of strength was very great ; the relative tenacities were as 100, 80, and 77, in test pieces from sample-bars such as are furnished under specification. James, repeating the experiment, obtained the figures 100, 66, and 60. The surface of a casting is usually, but not always, stronger than the interior of the mass.

The strength of cast iron of the usual foundry grades is generally increased by remelting, partly in consequence of the loss of carbon, and also, possibly, by the refining which occurs during the process. This change was noted by Wade when remelting No. 1 pig iron. Thus :

TABLE LXXX.
TENACITY OF REMELTED CAST IRON.

	SPECIFIC GRAVITY.	TENACITY. <i>T</i>	
		Lbs. per sq. in.	Kgs. per sq. cm.
First melting	7.032	14,000	984
Second melting	7.086	22,900	1,610
Third melting	7.198	30,229	2,207
Fourth melting	7.301	35,786	2,516

The same effect is produced by prolonged exposure to the flame of the reverberatory furnace, thus :

TABLE LXXXI.
TENACITY OF CAST IRON.

TIME OF FUSION.	TENACITY. <i>T</i>	
	Lbs. per sq. in.	Kgs. per sq. cm.
$\frac{1}{2}$ hour	17,843	1,254
1 hour	20,127	1,415
$1\frac{1}{2}$ hours	24,387	1,714
2 hours	34,496	2,425

Bramwell increased the strength of dark grades of cast iron more than 250 per cent. by four hours' fusion. In Fairbairn's experiments No. 3 iron was melted eighteen times, and a maximum increase of 220 per cent. was observed at the fourteenth melting.

245. Strain Diagrams of Cast Iron.—The accompanying diagram is the graphical representation of experiments made upon Salisbury cast iron referred to above. It is seen that such metal gives a parabolic strain diagram, and has no definite elastic limit. The Author has been accustomed to assume that the elastic limit may be taken at that point at which a

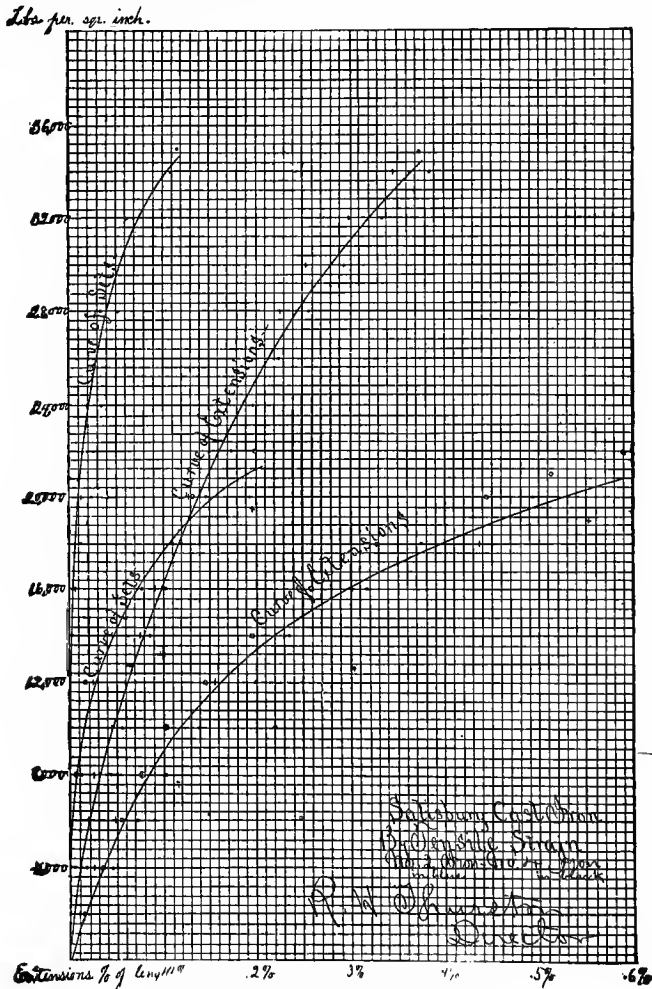

FIG. 82.—CAST IRON IN TENSION.

tangent to the curve makes an angle of 45° with the axes. This is fairly accurate for the harder varieties of iron, and, although less exact for softer irons, leads to no serious error.

246. Stays.—Where flat surfaces are secured against lateral pressure by stay-bolts, as is done in steam boilers, these bolts may yield either by breaking across, or by shearing the threads of the screw in the bolt or in the sheet. Such bolts should not be so proportioned that they are equally liable to break by either method, but should be given a large factor of safety (15 to 20) to allow for reduction of size by corrosion, from which kind of deterioration they are liable to suffer seriously. Wrought iron and soft steels are used for these bolts. They are secured through the plate, and the projecting ends are usually headed like rivets. Nuts are sometimes screwed on them instead of riveting them when they are not liable to injury by flame.

“Button-set” heads are from 25 to 35 stronger than the conical hammered head, and nuts give still greater strength.

Experiments made by Chief Engineers Sprague and Tower, for the U. S. Navy Department, lead to the following formula* and values of the coefficient a , p being the safe working pressure, t the thickness of plate, and d the distance from bolt to bolt :

$$p = a \frac{t^2}{d^2} \dots \dots \dots (28)$$

VALUES OF a IN BRITISH AND METRIC MEASURES.

	<i>A.</i>	<i>A_m.</i>
For iron plates and bolts.....	24,000	1,693
For steel plates and iron bolts.....	25,000	1,758
For steel plates and steel bolts.....	28,000	1,968
For iron plates and iron bolts with nuts.....	40,000	2,812
For copper plates and iron bolts.....	14,500	1,020

The working load is given in pounds on the square inch and kilogrammes per square centimetre, the measurements being taken in inches and centimetres. The heads, where riveted, are assumed to be made of the button shape.

* *Report on Boiler Bracing*; Washington, 1879.

The diameter of stay is made about $2\sqrt{t}$, the number of threads per inch 12, or 14 (5 or 6 per centimetre). A very high factor of safety, as above, is recommended for stays, to afford ample margin for loss by corrosion.

Lloyd's Rule for stayed plates is

$$p = \frac{a t_1^2}{p_1^2} \dots \dots \dots (29)$$

in which p is the working pressure in pounds on the square inch, t_1 the thickness of plate in sixteenths of an inch, and p_1 is the distance apart of the stays in inches.

The coefficient a has the following value :

- $a = 90$ for plate $\frac{7}{16}$ inch thick or less ; with screw stays and riveted heads ;
- $a = 100$ for plate $\frac{7}{16}$ inch thick or more ; screw stays and riveted heads ;
- $a = 110$ for plate $\frac{7}{16}$ inch thick or less ; screw stays and nuts ;
- $a = 120$ for plate $\frac{7}{16}$ inch thick or more ; screw stays and nuts ;
- $a = 140$ for plate $\frac{7}{16}$ inch thick or more ; screw stays with double nuts ;
- $a = 160$ for plate $\frac{7}{16}$ inch thick ; with screw stays, double nuts and washers.

The Board of Trade of Great Britain prescribes,

$$p = \frac{a (t_1 + 1)^2}{s - 6} \dots \dots \dots (30)$$

in which t_1 is the thickness of plate as above, and s is the area of surface supported, in square inches.

- $a = 100$ for plates not exposed to heat, and fitted with nuts and washers of 3" diameter and of $\frac{2}{3}$ the thickness of the plates ;
- $a = 90$ for same case, but with nuts only ;

- $a = 60$ where exposed to steam, and fitted with nuts and washers ;
- $a = 54$ for same case, with nuts only ;
- $a = 80$ where in contact with water ; with screw-stays and nuts ;
- $a = 60$ for latter case, and screw-stays riveted ;
- $a = 36$ for plates exposed to steam, screw-stays riveted.

Where girder-stays are used,

$$p = \frac{ad_1^3t_1^2}{(w - p_1)d_2l} \dots \dots \dots (31)$$

in which expression, d_1, t_1 are the depth and thickness of the girder, p_1 is the pitch of bolts carrying the girder ; d_2 is the distance between girders ; w is the width of crown ; l is the length of girder. Where one, two or three, and where four bolts, respectively, carry the girder, $a = 500, 750,$ and 850 .

Mr. D. K. Clark,* comparing data obtained experimentally with his own formulas for stayed surfaces, gives the following as safe values :

Deflection to the elastic limit,

$$d = \frac{d_1}{44} \dots \dots \dots (32)$$

where d is the "rise" of the arch, or the deflection, and d_1 the "pitch" of the stays.

Maximum pressure,

$$p = 407 \frac{tT}{d_1} \dots \dots \dots (33)$$

when t is the thickness and T the tenacity.

Elastic resistance,

$$\text{For iron, } p = 5,000 \frac{t}{d} \dots \dots \dots (34)$$

$$\text{For steel, } p = 5,700 \frac{t}{d} \dots \dots \dots (35)$$

* *Inst. C. E.*, 1877-78, Vol. LIII., abstracts.

For maximum pressure,

$$p = 0.215 \frac{tT}{d_1} \dots \dots \dots (39)$$

or, for iron,

$$p = 10,000 \frac{t}{d_1} \dots \dots \dots (40)$$

For steel,

$$p = 11,500 \frac{t}{d_1} \dots \dots \dots (41)$$

For cast iron,

$$p = 4,000 \frac{t}{d_1} \dots \dots \dots (42)$$

when t is the thickness, d_1 the diameter, and T the tenacity.

For spherical ends,

$$p = \frac{at}{\frac{d_1^2}{4v + v}} \dots \dots \dots (43)$$

where a is 108,000 for wrought iron, 125,000 for steel, 45,000 for cast iron, and v is the versed sine or rise of the head.

Lloyd's Rule for cylindrical shells of boilers is

$$p = \frac{abt}{d} \dots \dots \dots (44)$$

in which a is a constant, 10,000 for iron, b the percentage of strength of solid sheet retained at the joint, t is the thickness of the plate, and d the diameter of the shell. The value of b is thus reckoned (n = number of rows of rivets):

$$b = 100 \frac{p_1 - d_1}{p_1}, \text{ for the plate ;}$$

$$b = 100 \frac{na_1}{p_1 t}, \text{ for rivets in punched holes ;}$$

$$b = 90 \frac{na_1}{p_1 t}, \text{ for rivets in drilled holes ;}$$

where p_1 is the pitch of rivets; d_1 is their diameter; a_1 is the area of the rivet-section. When in double-shear, $1.75a_1$ is taken for a_1 . The factor of safety is taken at 6, and boilers are tested by water-pressure up to $2p$.

The iron is expected to have a tenacity of at least 21 tons per square inch; steel must bear 26 tons (3,307 to 4,095 kilogs. per sq. cm.).

Welds are found, when well made, to carry 75 to 85 per cent. of the sheet.

Steam-pipe is usually made with an enormous excess of strength, to meet accidental stresses, such as those due to motion of water within them. The Author has tested pipe broken by "water-hammer," as the engineer calls it, to 1,000 pounds per square inch (70 kilogrammes per sq. cm.) after it had been thus cracked in regular work in a long line, while the steam pressure was less than 100 pounds (7 kilogs. per sq. cm.). They had all been previously tested to about one-third this pressure.

248. Strength of Cast-Iron Cylinders.—Cylinders for steam engines are usually given a thickness greatly in excess of that demanded to safely resist the steam pressure; often, according to Haswell,

$$t = \frac{dp}{2500} + \frac{1}{8} \dots \dots \dots (45)$$

for vertical cylinders, where d is the internal diameter, and

$$t = \frac{dp}{2000} + \frac{1}{8} \dots \dots \dots (46)$$

for horizontal cylinders of considerable size.

In metric measures, kilogrammes and centimetres, these formulas become

$$t = \frac{dp}{200} + \frac{1}{3}, \text{ nearly } \dots \dots \dots (47)$$

$$t = \frac{dp}{160} + \frac{1}{3}, \text{ nearly } \dots \dots \dots (48)$$

If r_1 is the external, and r_2 the internal radius, T the tenacity of the metal, t its thickness, and p the intensity of the internal pressure, we have, for the *thin cylinder*, as an equation for equilibrium :

$$pr_2 = T(r_1 - r_2) = Tt, \text{ nearly } \dots \dots (49)$$

and

$$r_2 = \frac{Tt}{p} \dots \dots \dots (50)$$

$$t = r_1 - r_2 = \frac{pr_2}{T} \dots \dots \dots (51)$$

$$p = \frac{Tt}{r_2} \dots \dots \dots (52)$$

For the *thick cylinder*, however, the resistance at any internal annulus of the cylinder is less than T .

Thick Cylinders, technically so called, are those which are of such thickness that the mean resistance falls considerably below the full tenacity of the metal, as exhibited in thin cylinders, in low-pressure steam boiler shells, for example. Such cylinders are seen in the "hydraulic" press, and in ordnance.

*Barlow** assumes the area of section unchanged by stress, although the annulus is thinned somewhat by linear extension. If this is the fact, as the tension on any elementary ring must vary as the extension of the ring within the elastic limit, the stress in such element will be proportional to the reciprocal of the square of its radius, *i.e.*, it will be

$$p \propto \frac{1}{r^2} \dots \dots \dots (53)$$

and, taking the total resistance as $p'r_1$, when p' is the internal

fluid pressure, since the maximum stress at the inner radius is T , that on the inner elementary annulus is Tdx , and on any other annulus $\frac{Tr_2^2}{x^2} dx$; while the total resistance will be, on either side the cylinder,

$$p_1 r_2 = Tr_2^2 \int_{r_2}^{r_1} \frac{dx}{x^2} = T \frac{r_2(r_1 - r_2)}{r_2 + (r_1 - r_2)} = T \frac{r_2 t}{r_2 + t} \quad (54)$$

The maximum stress is at the interior, and may be equal, as taken above, to the tenacity, T , of the metal; then

$$T = \frac{p_1 r_1}{t} = \frac{p_1(r_2 + t)}{t} \quad \dots \quad (55)$$

and the thickness

$$t = \frac{p_1 r_2}{T - p_1} \quad \dots \quad (56)$$

while the ratio of the radii

$$\frac{r_1}{r_2} = \frac{Tt}{p_1} \div \frac{t(T - p_1)}{p_1} = \frac{T}{T - p_1} \quad \dots \quad (57)$$

Lamé's Formula, which is more generally accepted, and which is adopted by Rankine, gives smaller and more exact values than that of Barlow. In the above, no allowance is made for the compressive action of the internal expanding force upon the metal of the ring. The effect of the latter action is to make the intensity of pressure at any ring less than before by a constant quantity,

$$p \propto \frac{a}{r^2} - b,$$

and the tension by which the ring resists that pressure greater,

$$p' \propto \frac{a}{r^2} + b.$$

When $r = r_1, p = 0$; when $r = r_2, p = p_1$;

$$\text{then } p_1 = \frac{a}{r_2^2} - b, \text{ and } 0 = \frac{a}{r_1^2} - b,$$

$$a = p_1 \frac{r_1^2 r_2^2}{r_1^2 - r_2^2}; \quad b = p_1 \frac{r_2^2}{r_1^2 - r_2^2};$$

and the maximum possible stress on the inner ring is

$$T = \frac{a}{r_2^2} + b;$$

$$= p_1 \left(\frac{r_1^2}{r_1^2 - r_2^2} + \frac{r_2^2}{r_1^2 - r_2^2} \right).$$

$$T = p_1 \frac{r_1^2 + r_2^2}{r_1^2 - r_2^2} \dots \dots \dots (58)$$

$$p_1 = T \frac{r_1^2 - r_2^2}{r_1^2 + r_2^2} \dots \dots \dots (59)$$

and the ratio of inner and outer radii is

$$\frac{r_1}{r_2} = \sqrt{\frac{T + p_1}{T - p_1}} \dots \dots \dots (60)$$

Of these two formulas, the first gives the larger and consequently safer results, and, in the absence of certain knowledge of the distribution of pressure within the walls of the cylinder, is perhaps best.

For thick spheres, Lamé's formula becomes

$$p_1 = T \frac{r_1^3 - r_2^3}{r_1^3 - 2r_2^3} \dots \dots \dots (61)$$

$$\frac{r_1}{r_2} = \sqrt[3]{\frac{2(T + p_1)}{2T - p_1}} \dots \dots \dots (62)$$

Clark's formula* is more recent than the preceding. It is assumed that the expansion of concentric rings into which the cylinder may be conceived to be divided is inversely as their radii, and that the curve of stress will become parabolic if so laid down that the radii shall be taken as abscissas and the stresses as ordinates, the total resistance thus varying as the logarithm of the ratio of the radii. Then if the elastic limit be coincident with the ultimate strength, and

- T = the tenacity of the metal;
- R = the ratio, external diameter divided by internal;
- p = the bursting pressure;

$$p = T \times \text{hyp log } R \dots \dots \dots (63)$$

$$R = e^{\frac{p}{T}} \dots \dots \dots (64)$$

In other cases, instead of T take the value of the resistance at the elastic limit, and base the calculation of proportions upon the elastic limit and its appropriate factor of safety. The formulas as given are considered applicable to cast iron.

The strength of thick cast cylinders with heads cast in, may, however, sometimes be far in excess even of the calculated resistance of thin cylinders. The following are data obtained by test of cast iron (gun metal) cylinders made at the Watertown Arsenal, by Colonel T. T. S. Laidley, U. S. army.† These cylinders were eight in number, 11 inches (27.9 centimetres) in diameter, and 22½ inches (57 centimetres) long, bored out and lined with a thin copper or bronze tube or an iron cylinder and turned on the outside; they were, in fact, small lined guns. One set was lined with wrought iron, 0.9 inch (2.3

* *Rules and Tables*, p. 687.

† Ex. Doc. H. R., No. 12. Forty-seventh Cong., second session.

centimetres) thick; one lot with compressed bronze, 1/2 inch (1.27 centimetres) thick; and another with copper, 0.1 inch (0.254 centimetre) thick. Their dimensions were:

MARKS.	LENGTH.		EXTERNAL DIAMETER.		THICKNESS OF LINING.		DIAMETER OF BORE.	
	In.	Cm.	In.	Cm.	In.	Cm.	In.	Cm.
A 1	22 1/2	57	II	28	0.1	0.25	3.3	8.4
2	22 1/2	57	II	28	0.1	0.25	3.3	8.4
3	22 1/2	57	II	28	0.1	0.25	3.3	8.4
B 1	22	56	II	28	0.9	2.3	3.3	8.4
2	22	56	II	28	0.9	2.3	3.3	8.4
3	22	56	II	28	0.9	2.3	3.3	8.4
C 1	22	56	II	28	0.5	1.3	3.3	8.4
2	22	56	II	28	0.5	1.3	3.3	8.4
3	22	56	II	28	0.5	1.3	3.5	8.4

These cylinders were filled with wax and a plunger forced into the bore in the testing machine until bursting took place. The results were:

MARKS.....	A1.	A2.	A3.	B1.	B2.	B3.	C1.	C2.	C3.
Pressure: Lbs. per sq. in..	93,344	93,344,	92,366	74,936	81,120	71,853	86,722	82,420	70,888
Kgs. per sq. cm.	6,562	6,562	6,564	5,268	5,713	5,051	6,069	5,794	4,989

The cast iron used had the composition:

Phosphorus	0.371	Nickel	0.055
Silicon	1.471	Sulphur	0.043
Manganese	0.178	Carbon, combined	0.139
Copper	0.008	Carbon, graphitic	2.642
Cobalt	0.055		
Specific gravity	7.169		

Its tenacity was 30,000 pounds per square inch (2,109 kilogrammes per square centimetre).

The bronze and copper linings had tenacities of 42,190 and 45,290 pounds per square inch (2,966 and 3,184 kilogrammes per square centimetre) respectively, with exten-

sions of 5 and 7 per cent.; their specific gravities were 8.528 and 8.898.

Calling the diameters, inside and outside, 3.3 and 11 inches (8.4 and 28 centimetres, nearly), and the internal pressure 80,000 pounds per square inch (5,624 kilogrammes per square centimetre), it is seen that the total internal stress was $80,000 \times 3.3 = 264,000$ pounds per inch of length, and the stress on the metal $264,000 \div (11 - 3.3) = 34,300$ pounds per square inch (2,411 kilogrammes per square centimetre) nearly, and fully up to the strength estimated as a thin cylinder. The formulas for thick cylinders, judging from these tests, appear to be in error on the safe side; and very greatly so when, as is usually the case, the cylinder is short, and strengthened by having a head cast in. Such cylinders are generally also strengthened by very heavy flanges at the open end. Thin copper linings, as above, are often used to prevent the permeation of the iron by water.

249. Compression.—*Resistance of Iron and Steel to Compression* is measured by the same process as has already been described in treating of testing by tension. This form of resistance, is, however, governed in many cases by quite different laws, and is often modified by the size and shape of the piece tested to a much greater extent than is resistance to tensile stress. The method of rupture is not only different for different materials, but it is different with pieces of the same metal for every difference in size, shape, or proportion. Thus, a piece of weld, or ingot, iron or steel, if soft and tough, and in the form of a short cylindrical column, will gradually yield by crushing until it assumes the form of a cheese, or a button; the same metal in longer cylinders will yield similarly, until, reaching a certain limit of reduction, it will often split lengthwise; in still longer pieces, as in long columns, it will yield by bending laterally, and under a comparatively small load. A piece of hardened steel, or of brittle cast iron, will break by crushing into fragments, and will break up the more completely as it is harder and more brittle. Moderately tough cast iron will break into wedge-shaped pieces, and intermediate grades of iron and steel behave in

ways peculiar to each. Extremely hard metals exhibit no sign of yielding until their limit of resistance is reached, when they suddenly fly to pieces with great violence.

In all cases, resistance increases up to a limit beyond which the piece usually gives way suddenly, if the metal be hard or brittle; while ductile and malleable metals often offer constantly increasing resistance, the limit being reached only when the pressure becomes so great as to cause the metal to flow steadily. The larger the piece the higher the resistance per unit of cross-section.

In consequence of these variations due to form and size, it is even more necessary than when testing by tension to have a standard form of test-piece, and to report all observations as made upon such standard. Several writers have proposed a test-piece of one square inch area; but this is rather too large for many testing machines.

Kent* has proposed a cylindrical test-piece of one-half square inch cross-sectional area, and one inch in length (3.2257 square centimetres in area, and 2.54 centimetres long). Where not otherwise stated, this will be assumed as standard by the Author. The effect of alteration of form will be considered subsequently. (See Appendix: Strength of Steel Balls.)

250. The Structure of the Piece and its Chemical Composition determine the compressive resistance of iron and steel. With pure, well-worked metal, the resistance follows pretty closely the law by which tenacity changes with alteration in the proportion of carbon. Within the elastic limit, the behavior of the piece may be taken as the same with the two methods of stress; beyond that limit, the compressive strength usually exceeds the tensile in a proportion which varies greatly. In general, however, specifications may be based upon a formula similar in form to that given for tension thus:

$$\left. \begin{aligned} P &= 60,000 + 75,000 C \\ P_m &= 4,218 + 5,273 C \end{aligned} \right\} \dots \dots (65)$$

* *Van Nostrand's Magazine*, 1879.

in which P and P_m are the measures in British and metric units, respectively, of the resistance to compression.

Thus Bauschinger* obtained the following :

TABLE LXXXII.
RESISTANCE TO COMPRESSION.

CARBON.	RESISTANCE, C	
	Lbs. per sq. in.	Kilogs. per sq. cm.
0.14	67,994	4,780
0.19	76,672	5,390
0.46	90,043	6,330
0.51	99,561	7,000
0.55	87,765	6,170
0.57	93,314	6,550
0.66	93,314	6,550
0.78	103,912	7,305
0.87	127,169	8,940
0.96	140,683	9,890

The minimum figure may be taken as the crushing resistance of rather hard wrought iron ; but the results of tests of wrought iron are very variable, as might be expected from the differences known to exist, not only in the proportion of carbon in commercial wrought iron, but also in the proportions of other combining elements and of cinder. The figures given for wrought iron by various authorities vary from below 40,000 pounds (2,812 kilogrammes) to three times that amount. The Author would assume, in specifications, 55,000 pounds per square inch (3,868 kilogrammes per square centimetre) for test pieces of the standard dimensions, and would increase the figure, as above, with increase of carbon. The influence of other elements, including phosphorus and silicon, is quite as important here as in tension, and their effects are similar in character, but are as yet not as well determined as the effect of carbon.

* Weyrauch, p. 38.

Cast Iron has a power of resisting compression, which, as with other metals, may be taken within the elastic limit, or within the range of distortion and stress usual in application, as following the same law as resistance to extension. Its absolute value increases with the proportion of carbon, phosphorus, manganese, and silicon, in combination up to some undetermined limit, and decreases as the proportion is increased of graphitic carbon, of silicon, and other weakening substances. Sound castings will have maximum resistance to compression at a density not far from, though a little above, that which gives maximum tenacity. In general, specifications for cast iron under pressure should be similar in form to those framed for the same iron in tension. The iron should usually be No. 3 iron for ordinary work, and should have a density of 7.26 or 7.28.

The following figures are from the mean of a large number of tests of iron intended for ordnance :

TABLE LXXXIII.

RESISTANCE TO COMPRESSION—CAST IRON.

NUMBER.	SPECIFIC GRAVITY.	RESISTANCE. <i>C</i>		TENACITY.	
		Lbs. on sq. in.	Kilogs. on sq. cm.	Lbs. on sq. in.	Kilogs. on sq. cm.
1	7.087	99,770	7,014	20,877	1,468
2	7.182	139,834	9,830	30,670	2,171
3	7.246	158,018	11,118	35,633	2,505
4	7.270	159,930	11,253	39,508	2,777
5	7.340	167,037	11,743	32,458	2,282

The tenacities are presented for comparison, and the table so completed will enable all to be compared with the chemical composition and density of irons of similar tenacity as already given.

Tests of cast iron of similar grade to those reported pages

441, 444, as made by the Author in tension, gave the following results:

TABLE LXXXIV.
COMPRESSION AND DUCTILITY OF CAST IRON.

NUMBER.	RESISTANCE. <i>C</i>		TOTAL COMPRESSION.
	Lbs. on sq. in.	Kilogs. on sq. cm.	Per cent.
No. 2 iron.....	81,488	5,699	9.48
“ “	89,127	6,265	8.72
“ “	91,674	6,445	5.86
No. 4 “	127,323	8,951	9.95
“ “	127,323	8,951	9.50

The formula proposed by Hodgkinson for the rather weak cast iron used in his experiments is the following:

$$\left. \begin{aligned} P &= 170,763e - 36,318e^2 \\ P_m &= 12,004e - 2,553e^2 \end{aligned} \right\} \dots (66)$$

in which P and P_m are the loads in British and metric measures respectively, and e the corresponding elongation up to a limit which is rarely as high as one per cent., and is usually not far from the point of rupture.

251. Strain Diagrams of Cast Iron in Compression.—The accompanying figure contains the strain diagrams illustrating the experiments of the table. The elastic limit may be taken at one-half the ultimate resistance, although it cannot be definitely determined, since, as is best shown by the strain diagrams, the change in rate of distortion is too gradual to permit its identification. It is evident that the strain diagrams of iron and steel under compression have equations similar to that proposed for those of metal under tension. The stronger and stiffer sample is No. 4, and the weaker and more ductile is No. 2 iron. The small circles are the observations of extension and load; the crosses indicate corresponding sets.

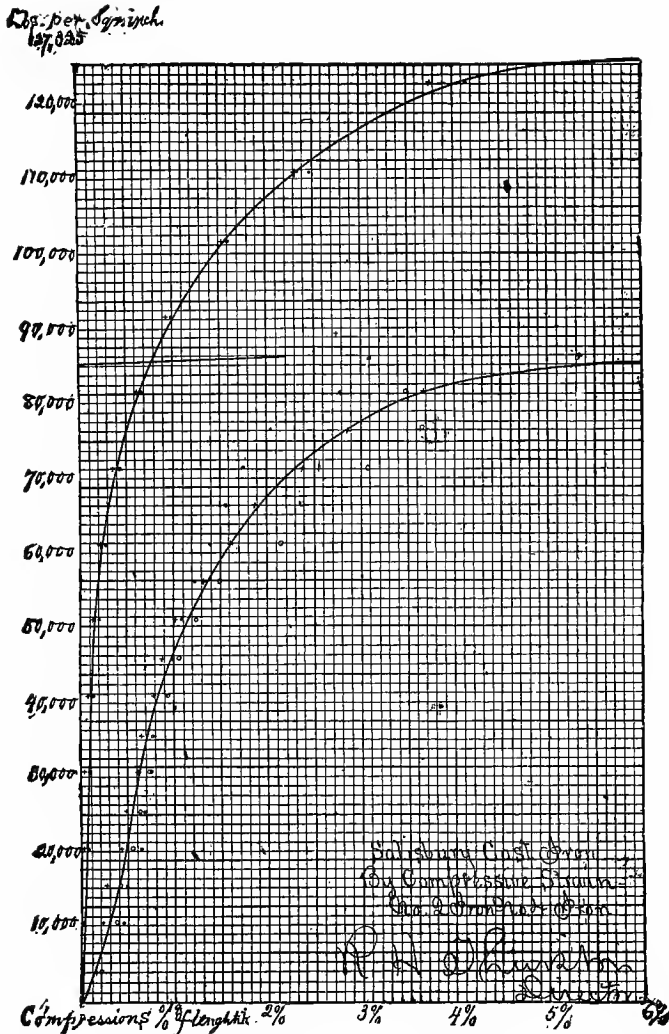

FIG. 83.—CAST IRON IN COMPRESSION.

252. Long Bars in Compression.—The following are the results obtained by Hodgkinson, testing cast-iron bars 10 feet (3.04 metres) long and of 1 inch (2.54 centimetres) area of section :

TABLE LXXXV.

RESISTANCE TO COMPRESSION, AND ELASTICITY OF CAST-IRON BARS.

LOAD. <i>C</i>		COMPRESSION.		MOD. ELASTICITY.	
Lbs. per sq. in.	Kgs. per sq. cm.	Total. <i>e</i>	Permanent.	Lbs. per sq. in.	Kgs. per sq. m.
2,064.74	145.1	.0001561	.00000391	13,231,300	9,293 × 10 ⁶
6,194.24	439.3	.0004981	.00003331	12,442,300	8,744 × 10 ⁶
10,323.73	725.5	.00082866	.00007053	12,467,100	8,761 × 10 ⁶
14,453.22	1,015.5	.00128025	.00011700	12,253,700	8,612 × 10 ⁶
18,582.71	1,305.9	.00154218	.00017085	12,058,100	8,474 × 10 ⁶
24,776.95	1,741.3	.00208016	.00036810	11,920,000	8,377 × 10 ⁶
33,030.8	2,326.7	.0029450	.00050768	11,222,750	7,887 × 10 ⁶

253. Wrought Iron in Compression.—The British “Steel Committee” tested iron and steel by compression in 1868–70, and found the elastic resistance of English wrought iron to lie between 10 and 14 tons per square inch, averaging about 12, or nearly 26,000 pounds per square inch (1,827.8 kilogrammes on the square centimetre), and an extension, to the elastic limit, of 0.097 per cent. (0.001 nearly).

Experimenting on steels, this committee found the elastic limit, in compression, at 50,000 pounds per square inch, nearly (3,515 kilogrammes per square centimetre), and at a percentage of compression ranging from 0.000065 to 0.000080 per ton per square inch, and a total of usually not far from 0.0018, without regard to kind of steel.

Kirkaldy, experimenting on the softer and purer iron of Sweden, obtained an average of about 25,000 pounds (1,757.5 kilogrammes on the square centimetre), and an ultimate resistance of nearly 175,000 pounds per square inch, with a 1-inch cube (12,300 kilogrammes on the square centimetre), and about one half that amount on a 1½-inch (3.82 centimetres) bar 2 diameters long. Ten diameters' length reduced the figures to about 15 per cent. of the maximum. The compression was nearly 50 per cent.

Tangye found the resistance of small areas of larger

masses under compression to be sensibly overcome at about 50,000 pounds per square inch, and a deep indentation to be produced by double that load (3,515 and 7,030 kilogrammes per square centimetre).

254. **Flues and Cylinders** subjected to external pressure resist that pressure in proportion to their stiffness and their compressive strength if thin, and if thick* sustain a pressure proportional to their thickness and maximum resistance to crushing.

Fairbairn,* experimenting on flues of thin iron, 0.04 inch (0.102 centimetre), of small diameter, 4 inches (10.2 centimetres) to 12 (31 centimetres), and from 20 inches (50.8 centimetres) to 5 feet (1.52 metres) long, found that their resistance to collapse varied inversely as the product of their lengths and their diameters, and directly as the 2.19 power of their thickness.

The following equation fairly expressed his results when p is the external pressure in pounds per square inch, t their thickness in inches, d their diameter. L is the length in feet :

$$t = \sqrt[2.19]{\frac{pdL}{806,000}}; p = 806,000 \frac{t^{2.19}}{dL} \quad \dots \quad (67)$$

or, for the length in inches,

$$p = 9,672,000 \frac{t^{2.19}}{dl} \quad \dots \quad (68)$$

In metric measures, kilogrammes and centimetres diameter, and metres of length,

$$p = 68,000 \frac{t^{2.19}}{dL}, \text{ nearly} \quad \dots \quad (69)$$

$$t = \sqrt[2.19]{\frac{pdL}{68,000}} \quad \dots \quad (70)$$

* *Useful Information.* Second Series.

For elliptical flues take $d = \frac{2a^2}{b}$; where a is the greater and b the lesser semi-axis.

These equations probably give too small values of t for heavy flues under high pressure.

Belpaire's rule, deduced from Fairbairn's experiments, is,

$$p = 1,057,180 \frac{t^{2.081}}{l^{0.564} a^{0.889}} \quad \dots \quad (71)$$

Lloyd's rule for flues is

$$p = \frac{at^2}{Ld} \quad \dots \quad (72)$$

in which a is made 89,600 pounds per square inch.

The *British Board of Trade rule* is, for cylindrical furnaces with butted joints,

$$p = \frac{at^2}{(L+1)d} \quad \dots \quad (73)$$

in which a is 90,000, provided, always,

$$p < 8,000 \frac{t}{d}.$$

For large joints $a = 70,000$ unless beveled to a true circle, when $a = 80,000$. If the work is not of the best quality, these values of a are reduced to 80,000, 60,000, and 70,000.

The factor of safety in boiler work should not be allowed to fall below 6. "Corrugated" flues are claimed to have double the strength and much greater elasticity than "plain" flues.

255. Resistance of Columns, Posts, or Struts.—The resistance of parts of structures under compression is often determined largely by their form and by the method of putting them together or of building them up. In construction

such parts are called pillars, posts, or struts, and are given all the various forms shown in the accompanying figures:



FIG. 84.—CROSS SECTIONS OF COLUMNS.

Their ends are usually fitted with bases or “shoes” of cast or forged iron, having, in accepted practice, a minimum thickness of

$$t = \frac{P}{12,000d};$$

where P is the total load in pounds, and d the diameter in inches of the pin sustaining the strut, as is common in American bridge construction. The first of the forms here shown is known as the “Phœnix” column. In all such pieces the resistance to compression is less than the figures already given for short pieces yielding by actual crushing.

256. Flexure of Columns.—It is shown, in works on the theory of the strength of materials, that the general equation for flexure of any piece subjected only to stress producing bending is, when I is the principal moment of inertia,*

$$EI \frac{d^2y}{dx^2} = -Py \quad (74)$$

the second member being negative when, as in the bending of very long columns, the moment of the flexing force is negative with respect to the moment of the resisting forces, y being the ordinate of any point in the curved axis, and x the abscissa, as the curve of the beam is concave to the axis of x . From this expression is derived, by Euler and later

* Discovered, and proven, by Prof. Robinson to be the principal moment for all cases. *Vide Strength of Wrought Iron Bridge Members; Van Nostrand's Science Series*, No. 60, equation (5).

authors, an equation for the load on a column, when both ends are rounded or pinned, thus :

The integral of equation 74 is,

$$y = a \sin \frac{x}{\sqrt{\frac{EI}{P}}};$$

but to make $y = 0$ at the extremities of the column, when $x = l$, we must have

$$\frac{l}{\sqrt{\frac{EI}{P}}} = \pi,$$

or equal some multiple of π ; thence we may put,

$$\frac{l}{\pi} = \sqrt{\frac{EI}{P}},$$

and, therefore,

$$P = \frac{\pi^2}{l^2} EI = 10 \frac{EI}{l^2}, \text{ nearly } \dots \dots (75)$$

in which l is the length, E the modulus of elasticity, P the load, and I the moment of inertia of the transverse section.

257. Strength of Columns of Great Length.—Since this resistance is independent of the extent of flexure, it is evident that, passing the limit of elasticity, where the law of variation of resistance changes, as will be seen by studying strain diagrams given later, the formula gives the breaking load, when, as in the case here taken, there is no external force aiding the column in the effort to retain its form. This expression is proposed by Navier* for columns 20 diameters or more in length. Later writers would restrict it to still more slender columns—30 to 40 diameters.

* *Resumé des Leçons* : Paris, 1838, p. 204.

When the column is cylindrical, the equation becomes,

$$P = \frac{1}{64} \pi^3 E \frac{d^4}{l^2} = \frac{1}{2} E \frac{d^4}{l^2}, \text{ nearly (76)}$$

and for square columns,

$$P = \frac{1}{12} \pi^3 E \frac{b^4}{l^2} = \frac{5}{6} E \frac{b^4}{l^2}, \text{ nearly . . . (77)}$$

This equation may be used for flat-ended columns 60 or 70 diameters long by multiplying the second member by 4, and to columns having one end flat, the other rounded, when 40 or 50 diameters long, by making the factor 2 ;* making the general equation,

$$P = 40 \frac{EI}{l^2}, \text{ nearly (78)}$$

and

$$P = 20 \frac{EI}{l^2}, \text{ nearly (79)}$$

While the equations become for cylinders,

$$P = 2 E \frac{d^4}{l^2} (80)$$

$$P = E \frac{d^4}{l^2} (81)$$

and for square pillars,

$$P = 3\frac{1}{3} E \frac{b^4}{l^2} (82)$$

$$P = 1\frac{2}{3} E \frac{b^4}{l^2} (83)$$

Hodgkinson's simple formula for the same column is given :

For long columns, fixed, solid,

$$\text{Cast iron, } P = 49.4 \frac{d^{8.55}}{L^{1.7}} (84)$$

* See *Strength of Bridge Members*, Robinson : New York, D. Van Nostrand, 1882, p. 107.

$$\text{Wrought iron, } P = 149.7 \frac{d^{3.55}}{L^{1.7}} \dots \dots (85)$$

For hollow columns,

$$\text{Cast iron, } P = 49.6 \frac{d_1^{3.55} - d^{3.55}}{L^{1.7}} \dots \dots (86)$$

the diameter being taken in inches, the length in feet, and the load in tons.

258. Standard Formulas for Strength of Columns.—In all ordinary cases of yielding of columns, and in all cases of short columns, even with rounded ends, the lateral resistances must be considered. For such cases, engineers are accustomed to use what is generally known as Gordon's formula—more properly called Tredgold's*—or a modification of wider application proposed by Rankine.†

Tredgold's formula is the following:

$$P = \frac{Cbd}{1 + a \left(\frac{l}{d}\right)^2} \dots \dots \dots (87)$$

for rectangular columns. The values of a and C are given as follows* in British measures:

	a	C
Cast iron.....	0.18	9,562
Wrought iron.....	0.16	17,800

This formula applies to pillars with rounded ends:

Gordon obtained constants for this formula from various sources, and it has become more generally known by his name. The following are the constants obtained from hollow columns for the modified formula, for fixed ends:

$$P = \frac{CK}{1 + a \left(\frac{l}{d}\right)^2} \dots \dots \dots *(88)$$

* *Tredgold on Strength of Cast Iron*, second edition, p. 183.

† *Applied Mechanics*, p. 305.

MATERIAL.	SECTION.	C.		a.
		Lbs. per sq. in.	Kilogs. per sq. cm.	
Cast iron	Circle.	80,000	5,624	0.0025
Cast iron	Square.	80,000	5,624	0.002
Wrought iron	Circle.	36,000	2,628	0.00033
Wrought iron	Square.	36,000	2,628	0.00017

C is the maximum resistance to crushing.

For rounded ends, or pin-connections, multiply a by 4, and for one end fixed, by 2.

In Gordon's formula, the load is in pounds the area, K , in square inches, and the length and diameter in the same units. All the values of C are lower than it is now customary to take them.

Rankine's formula is of more general application than Tredgold's, although derived by a similar process. It has the following form for a strut fixed at both ends :*

$$P = \frac{CK}{1 + a \left(\frac{l}{k}\right)^2} \dots \dots \dots (89)$$

in which P is the load, C the resistance to crushing in short pieces, both in the same terms, K the sectional area, l and k the length of the column, and the least radius of gyration of its cross section in the same units. For rounded ends, a is multiplied by 4, and for one end fixed, by $\frac{1}{3}$. The following are values of C and a as given by Rankine :

	C.		a.
	Lbs. on sq. in.	Kilogs. on sq. cm.	
Cast iron	80,000	5,624	$\frac{1}{400}$
Wrought iron	36,000	2,628	$\frac{1}{5800}$

* Rules and Tables, p. 210.

The formula of Tredgold and its modifications may be thus derived :

If the load on the head of a column be P , the intensity of the stress due that load, at any section, K , is

$$p' = \frac{P}{K} \dots \dots \dots (90)$$

and this is, as a maximum in short pieces and masses, equal to the resistance, C , to crushing given in the preceding tables.

But when a long pillar or column yields, it does so by bending transversely, and follows the law already given in connection with the deduction of Euler's formula. This brings a stress, p'' , due to bending solely, upon parts already strained by the stress, p' , producing a maximum,

$$p' + p'' = C \dots \dots \dots (91)$$

The value of p'' varies directly as the moment and inversely as the breadth and the square of the thickness of a rectangular section,* or as the cube of the diameter for a circular section of column, and if M is the bending moment of the load for a square section,

$$C = p' + p'' = \frac{P}{K} + a \frac{M}{bd^2} \dots \dots \dots (92)$$

and since the maximum allowable deflection is proportional to the square of the length divided by the thickness,

$$C = \frac{P}{K} + aP \frac{l^2}{bd^3}$$

$$= \frac{P}{K} \left[1 + a \left(\frac{l}{d} \right)^2 \right] \dots \dots \dots (93)$$

* Rankine ; *Applied Mechanics*, p. 305.

and the crushing load is

$$P = \frac{CK}{1 + a \left(\frac{l}{d}\right)^2} \dots \dots \dots (94)$$

while the maximum intensity of pressure will be

$$p = \frac{P}{K} = \frac{C}{1 + a \left(\frac{l}{d}\right)^2} \dots \dots \dots (95)$$

the values of which are always less than C , and decrease as the column is lengthened, finally becoming identical with that obtained with Euler's method.

It is evident that the same formula, with suitable alteration of the constant, a , may be written, as by Rankine, in (89).

The following are values of k^2 for solid sections and for hollow sections with thin sides :

TABLE LXXXVI.
VALUES OF RADII OF GYRATION.

<i>Form of Section.</i>	k^2 .
Solid ; rectangle.....	$\frac{1}{12} h^2$.
Thin ; square.....	$\frac{1}{6} h^2$.
Thin ; rectangle.....	$\frac{h^2}{12} \cdot \frac{h + 3b}{h + b}$
Solid ; cylinder.....	$\frac{1}{16} h^2$.
Thin ; cylinder.....	$\frac{1}{8} h^2$.
Angle iron ; equal flanges, of width b	$\frac{1}{24} b^2$.
Angle iron ; unequal flanges, of widths b and h	$\frac{b^2 h^2}{12 (b^2 + h^2)}$.
Cross of equal arms.....	$\frac{1}{24} h^2$.
H-iron ; breadth of flanges, b ; area, A ; area of web, B	$\frac{b^2}{12} \cdot \frac{A}{A + B}$.
Channel iron ; depth flange + $\frac{1}{2}$ thickness of web = h ; area web = B ; area flanges = A ...	$h^2 \left(\frac{A}{12 (A + B)} + \frac{AB}{4 (A + B)^2} \right)$

The value of C is 36,000 ; $a = \frac{1}{38000}$ for wrought iron ; $C = 80,000$; $a = \frac{1}{8400}$ for cast iron ; $h =$ least dimension.

For octagonal and other sections approaching either of the above figures, the nearest regular figures may be circum-

scribed about the line traversing the middle line of the metal composing the given section, and its dimensions used in the formula.

Robinson,* starting from the equation of moments (74) already given, and introducing stresses acting both longitudinally and transversely, has obtained more complex, but more exact expressions for the maximum loads sustained by columns thus :

If C is the coefficient for maximum resistance to crushing, as before, K the area of section, I its moment of inertia about an axis at its centre of gravity, d_1 the distance from the centre of gravity of the section to the fibre which breaks first, l the length of column in the same units, E the modulus of elasticity, we shall have

For flat ends :

$$P = \frac{CK}{1 + \frac{Kd_1^2}{2I} \left(\sqrt{1 + \frac{Cl^2}{\pi^2 E d_1^2}} - 1 \right)} \dots (96)$$

For rounded or pinned ends :

$$P = \frac{CK}{1 + \frac{Kd_1^2}{2I} \left(\sqrt{1 + \frac{4Cl^2}{\pi^2 E d_1^2}} - 1 \right)} \dots (97)$$

For one flat end :

$$P = \frac{CK}{1 + \frac{Kd_1^2}{2I} \left(\sqrt{1 + \frac{16}{9} \frac{Cl^2}{\pi^2 E d_1^2}} - 1 \right)} \dots (98)$$

For cylindrical columns, these become :

For flat ends,

$$P = \frac{\pi r^2 C}{1 + 2 \sqrt{\left(1 + \frac{Cl^2}{Er^2 \pi^2} \right) - 2}} \dots (99)$$

* *Strength of Wrought Iron Bridge Members, Van Nostrand's Science Series, No. 60.* By Prof. S. W. Robinson ; Ohio State University, p. 102, *et seq.*

For rounded ends,

$$P = \frac{\pi r^2 C}{1 + 2 \sqrt{\left(1 + \frac{4Cl^2}{Er^2\pi^2}\right) - 2}} \dots (100)$$

For one flat end,

$$P = \frac{\pi r^2 C}{1 + 2 \sqrt{\left(1 + \frac{16}{9} \frac{Cl^2}{\pi^2 Er^2}\right) - 2}} \dots (101)$$

These formulas give identical results with Euler's when the columns with flat ends exceed 72, with rounded ends 36, and those with one flat end 55 diameters in length.

For important work, the Rankine formula is preferred to the earlier expressions, and Robinson's can be used for a still wider range of conditions, and will probably give still more accurate results. The latter, in fact, involves the former, for, grouping the numerical factors into one coefficient, a , and introducing the principal radius of gyration, k , making

$$\frac{aCl^2}{4\pi^2 Ek^2} = v, \quad \text{and} \quad \frac{k^2}{d_1^2} = z,$$

we have

$$P = \frac{CK}{1 + v - v^2z + 2v^3z^2 - 5v^4z^3 + \text{etc.}} \dots (102)$$

which becomes Rankine's formula if the terms following the first two in the denominator are dropped. Greater accuracy can be secured by retaining all.

The general formulas to include all cases and conditions are:

For ordinary columns,

$$P = \frac{CK}{1 + \frac{d_1^2}{2k^2} \left\{ \sqrt{\left(1 + \frac{aCl^2}{\pi^2 Ed_1^2}\right) - 1} \right\}} \dots (103)$$

For very long columns (Euler),

$$P = \frac{4}{a} EK\pi^2 \frac{k^2}{l^2}.$$

At certain lengths these formulas give identical results, as when, for instance, cylindrical columns with flat ends = 72 diameters in length. To determine which formula to use in a particular case, the following criterion gives the length for identical results :

$$\frac{l}{2d_1} = \sqrt{\left(\frac{\pi^2 k E}{a d_1 C} \cdot \frac{d_1 + k}{d_1}\right)} \dots \quad (104)$$

In *Pin Connections of Columns* a certain amount of friction occurs, which, in the absence of jar, may aid in holding the column in shape. Robinson has adapted his formula to this case, and also to distinguish between fixed and square ends, by giving a in the above formulas the value,

$$a = \frac{4}{\left(1 + \frac{k_c \sqrt{K_c} + k_a \sqrt{K_a}}{2d_1 \sqrt{K_m}} + f \frac{r_a + r_b}{2k_m}\right)^2} \dots \quad (105)$$

in which k_c, k_a, K_c, K_a, K_m , are the principal radii of gyration and the areas of cross section at the two ends and at the middle of the column; r_a, r_b are the radii of the pins, and f is the coefficient of friction; f is from 0.2 or 0.3 in new to 0.5 in old columns. For fixed ends, change d_1 to k_m .

The formulas are rational expressions, and are applicable to members of any material of which the values of E and C are known, applying a factor of safety to C . In using the Rankine formula it will be seen that the assumed apparent factor of safety results, in fact, in the production of a higher actual factor.*

It is considered by the Author that "low" steel will be found a better material for struts than wrought iron. The Tredgold formula and its modifications can be used for such cases, provisionally making the value of C from 50,000 to 75,000 British (3,513 to 5,272 for metric) measures, according to quality of steel chosen, and that of a from $\frac{1}{30000}$ to $\frac{1}{20000}$, the larger figures being used with the harder steels. Direct ex-

* Robinson, p. 158.

periment is needed to determine these coefficients for the new metal now coming into the market.

259. The Geometrical Moment of Inertia, I , of the cross section, used in the preceding formulas and in those to be given later, is easily obtained by the algebraic formula : it is the sum of "the moments of the moments" of all elementary areas about any axis, and is given by the following expression :

$$I = \iint y^2 dy \cdot dz,$$

when the form of the section can be expressed by an equation taking the origin of co-ordinates at the centre of gravity of the section and the axis of z in the plane of bending. The square of the radius of gyration, or

$$k^2 = \frac{\iint y^2 dy \cdot dz}{\iint dy \cdot dz} \dots \dots \dots (106)$$

is obtained by dividing the moment of inertia of the surface by its area.

For many cases arising in practice, the value of I may be obtained by a simple graphic construction, thus: Divide the section into parallel layers, as in Fig. 85, and determine their

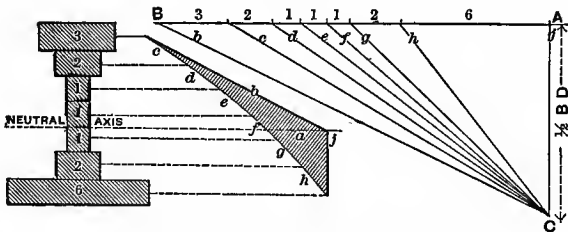

FIG. 85.—MOMENT OF INERTIA.

areas as in the sketch, 3, 2, 1, 1, 1, 2, 6. Lay off these quantities along a line, AB , thus making the total length equal to the area of the whole section. Draw $AC \doteq \frac{1}{2}AB$ and perpendicular to AB , and draw radii vectores from C to each point of division on AB . Finally, draw from horizontal lines passing through the centre of figure of each layer other lines parallel to the radii, as b parallel to b , c parallel to c , d parallel

to d , and thus form a closed polygon, the intersection of sides b and j locating the neutral axis.* Then if K is the area of the cross section taken, and K' is that of the polygon,

$$I = KK',$$

and

$$k^2 = \frac{I}{K} = K'.$$

When it is not possible or is difficult to integrate the expression

$$\iint y^2 dy dz = I,$$

and where the preceding graphical method is not convenient of application, a process of summation may be made to give a fair degree of approximation to a correct value. Thus, in the preceding figure, measure up the areas of the several layers, multiply each by the square of its distance from the "neutral line" or centre line passing normally to the plane of bending, and add the products to obtain the value of I . The more numerous the layers the more exact the result.

The following are values of the geometrical moment of inertia of the more commonly adopted figures of section :

TABLE LXXXVII.
MOMENTS OF INERTIA.

SECTION I .		SECTION I .	
1. Rectangle, solid.....	$\frac{bd^3}{12}$	6. Circle, solid.....	$\frac{\pi d^4}{64}$
2. Rectangle, hollow.....	$\frac{bd^3 - b_1d_1^3}{12}$	7. Circle, hollow.....	$\frac{\pi}{64}(d^4 - d_1^4)$
3. Square, solid.....	$\frac{d^4}{12}$	8. Ellipse, solid.....	$\frac{\pi}{64}bd^3$
4. Square, hollow.....	$\frac{d^4 - d_1^4}{12}$	9. Ellipse, hollow..	$\frac{\pi}{64}(bd^3 - b_1d_1^3)$
5. T-section.....	$\frac{bd^3 + b_1d_1^3}{12}$	10. I or II-section...	$\frac{bd^3 - b_1d_1^3}{12}$

in which expressions b is the breadth, d the depth of the rectangle, or the outside diameter in the circle and ellipse, b_1 , d_1 the minimum measure of the same lines, all except b , b_1 , in the plane of bending.

* Molesworth.

The moment of inertia is the *principal* moment of inertia, even when the applied forces are acting obliquely or longitudinally, and is therefore to be taken about the axis through the centre of gravity for all the formulas given, for either beams and girders or columns, and whatever the line of action of the applied effort.

260. Practical Applications.—The formula of Gordon for the resistance of iron columns to compression is used by nearly all engineers, the values of C and a being determined by the character of the material, and form of the column. For good iron and good work, such as should be found in all truss bridges, C may be taken at 40,000 pounds per square inch (2,812 kilogrammes per square centimetre), and for solid columns of square section, or hollow cylinders, $a = \frac{1}{3,000} = 0.000333$. For the steels, C may be taken at the figures already given for C , their resistance to compression, using a higher factor of safety for the harder grades, which are, however, rarely used in this form. Six is a usual value for the factor of safety.

It is evident that the value of a is variable with the form of column, and that the strongest form is that in which a is smallest. Cleeman * has calculated several values from experiment, and finds a range from $\frac{1}{594}$ to $\frac{1}{198,218}$.

These formulas are correct only for a single application of load. For repeated stresses, "Wohler's Law" must be considered, and for intermissions the law, discovered by the Author, of elevation of the primitive elastic limit (Chap. X.).

Since the theory of long columns, such as break by flexure, assumes their perfect elasticity; in conformity with Hooke's law, up to the point of rupture; since this is only true up to the limit of elasticity; and since, beyond the elastic limit, the rate of increase of resistance to distortion ceases to be directly proportional to the rate of distortion, but increases at some lower rate than that which holds up to that limit; it follows that, within the limit of elasticity, where such a limit exists, the maximum load produces a flexure

* *Proc. Engineers' Club of Phila.*, No. 2, 1881.

which, as the equations show, is indeterminate. Once passing the elastic limit, the load which the flexed column can support becomes less and less at a rate determined by the method of decrease of the ratio referred to. A column "crippled" is therefore a column broken, and once the lateral yielding commences, the load will destroy it. The accepted theory is therefore a safe theory for practical use. The factor for wrought iron, five, even, often adopted by engineers designing bridges, is by many considered as giving an ample margin of safety, and six is thought large. Columns as ordinarily designed are, therefore, probably perfectly safe. It is never intended that the elastic limit shall be exceeded.

Gordon's constants for columns, as derived from Hodgkinson's experiments, have been generally accepted; but the values of the constants, C and a , are evidently to be determined for each kind of metal and each form of column.

The values of p from Tredgold's formula (Gordon's constants, $C = 36,000$; $a = \frac{1}{3000}$), and also the values of $\frac{p}{4}$, are as follows, in British measures, for wrought-iron columns:

TABLE LXXXVIII.

MAXIMUM PRESSURES; CYLINDRICAL W. I. COLUMNS—C. A. SMITH.

(British measures; to obtain metric, multiply by 0.0703.)

$\frac{l}{d}$	$\frac{p}{4}$	p	$\frac{l}{d}$	$\frac{p}{4}$	p	$\frac{l}{d}$	$\frac{p}{4}$	p	$\frac{l}{d}$	$\frac{p}{4}$	p	$\frac{l}{d}$	$\frac{p}{4}$	p
1	8,097	35,088	21	7,847	31,388	41	5,768	23,072	61	4,027	16,108	81	2,824	11,296
2	8,098	35,052	22	7,750	31,000	42	5,667	22,668	62	3,945	15,780	82	2,777	11,008
3	8,073	35,892	23	7,651	30,604	43	5,568	22,272	63	3,874	15,496	83	2,730	10,920
4	8,052	35,868	24	7,550	30,200	44	5,470	21,880	64	3,805	15,220	84	2,685	10,740
5	8,025	35,700	25	7,448	29,792	45	5,373	21,492	65	3,737	14,948	85	2,641	10,554
6	8,025	35,574	26	7,345	29,380	46	5,277	21,108	66	3,671	14,684	86	2,597	10,388
7	8,855	35,420	27	7,240	28,960	47	5,181	20,732	67	3,605	14,420	87	2,555	10,220
8	8,812	35,248	28	7,135	28,540	48	5,090	20,360	68	3,541	14,164	88	2,513	10,052
9	8,763	35,052	29	7,029	28,116	49	4,999	19,996	69	3,479	13,916	89	2,472	9,888
10	8,710	34,840	30	6,923	27,692	50	4,909	19,636	70	3,416	13,672	90	2,432	9,728
11	8,651	34,604	31	6,816	27,264	51	4,820	19,280	71	3,358	13,432	91	2,393	9,572
12	8,588	34,352	32	6,710	26,840	52	4,733	18,932	72	3,299	13,196	92	2,355	9,420
13	8,520	34,080	33	6,603	26,412	53	4,648	18,592	73	3,242	12,968	93	2,318	9,272
14	8,448	33,792	34	6,496	25,984	54	4,564	18,256	74	3,185	12,740	94	2,281	9,124
15	8,372	33,488	35	6,390	25,560	55	4,481	17,924	75	3,130	12,520	95	2,245	8,980
16	8,292	33,168	36	6,285	25,140	56	4,400	17,600	76	3,076	12,304	96	2,210	8,840
17	8,209	32,836	37	6,180	24,720	57	4,321	17,284	77	3,024	12,096	97	2,176	8,704
18	8,123	32,492	38	6,076	24,304	58	4,243	16,972	78	2,972	11,888	98	2,142	8,568
19	8,033	32,132	39	5,972	23,888	59	4,166	16,664	79	2,922	11,688	99	2,109	8,436
20	7,941	31,764	40	5,869	23,476	60	4,091	16,364	80	2,872	11,488	100	2,077	8,308

By a comparison of this formula and the experiments upon which it was based, Messrs. B. Baker and C. A. Smith* find that the ultimate stress of tee, angle, cross, beam, and channel-iron columns is given very nearly by the Tredgold formula with $\frac{3l}{2d}$ used for $\frac{l}{d}$.

Unwin, for this case,† makes $C = 19$ tons (or tonnes), and $a = 0.0011$.

Solid Steel Pillars or Columns, fixed at the ends, may be proportioned by the Tredgold formula, using the constants $C = 30$ tons (or tonnes) for mild steels, and $C = 50$ for steel of about 0.8 per cent. carbon, and making $a = 0.001$ for high steel, $a = 0.0007$ for mild steel in cylindrical columns; $a = 0.0006$ for hard, and $a = 0.0004$ for soft steels in pillars of square section. For rounded or jointed ends, take $4a$ in place of a . Such columns are used in machinery, and are generally of slender form.

An *open column* built of channel bars united by latticed bracing, is to be taken as if the web were solid plate. Thus taken, and with the value of C obtained by tests of compressive strength of columns having lengths equal to their diameters, Rankine's rule, as here given, was found by Bouscaren to give results on square posts differing within 4 per cent. from those obtained by experiment. In the case of columns of less regular form and of less excellent workmanship, differences of 20 per cent. should be anticipated. Bridge columns and struts are now made very generally of either the Phoenix Section or of the simplest forms of section already figured above. The formulas given are readily applied to any of these shapes.

A moderately hard, strong, close-grained iron is best for columns, as well as for beams or other structures in which stiffness is essential. The thorough connection of parts is essential to secure the utmost strength of column and economy of material. Imperfect work in this direction has been found to reduce strength 20 per cent. The column should be so well put together that it may fail only by a general change of

* *R. R. Gazette*, Nov. 1, 1875, p. 465.

† *Iron Bridges and Roofs*.

form and not by local injury. Where the column rests at one end upon a pin, the fit should be exact.

The investigations of Hodgkinson, which form the basis of the engineer's work in this direction, indicated that, in practice, the strength of *long* columns with fixed ends is three times as great as those with joints or rounded ends; that the column or strut having one fixed and one rounded or loose end, is intermediate, the three cases having the relation 1, 2, 3. When having flat ends, they yield at three points—in the middle and near each end—when rounded or loose, in the middle only. The increase of the diameter at the middle gives greater strength to solid pillars, but has little effect on hollow columns; the gain, in the first case, is 10 or 12 per cent. The load carried on columns of similar form varies as the cross section.

Cast-iron Columns are used in many structures, and, if sound and of good material, are reliable. They are economical in cost of manufacture and of fitting, and are more durable when exposed to the weather than are columns of wrought iron. They are less safe where exposed to shock, and are, for that reason, seldom used in bridges or in structures liable to injury by that cause. Cast-iron pillars are more liable to defects of form of structure and of material than those of wrought iron; they are also more subject to injury by shock; they should always be designed with a higher factor of safety than wrought-iron pillars. The engineer has less confidence in cast iron, also, because of the difficulty of testing and of inspecting it satisfactorily. Cast-iron columns should not be given a thickness less than about $0.004l$, nor in any case less than $\frac{5}{8}$ inch (1.6 centimetres). Some engineers make this limit *o.1d.* Slight inequalities of thickness do not usually impair their strength.

The flanges of columns should be turned and fitted to the base, which should itself be smoothly faced to receive the column. Where the ends can be spread to form capital and base, the structure is greatly stiffened.

For short pillars of large diameter, cast iron is stronger than wrought, but when the length exceeds 15 to 20 diame-

ters, according to quality of metal, the wrought-iron column becomes the stronger, equaling steel at 200 diameters.

Short Columns, falling well within 25 diameters in length, whether of wrought iron, cast iron, steel, or timber, may be dimensioned on the assumption that they have nearly the maximum strength of the metal, and the factor of safety adjusted to cover the small discrepancy so introduced.

The proof load is often made one half the breaking load with wrought iron, and one third for cast-iron columns, while the working load is usually between one quarter and one sixth the breaking load.

Piston rods are usually considered as columns fixed at one end and rounded at the other.

Common practice has produced piston rods for steam engines which follow, very fairly, the formula

$$d = \sqrt[4]{\frac{d'^2 \rho L^2}{15,000}} + \frac{d'}{80} \dots \dots \dots (107)$$

in which d is the diameter of the piston rod, d' that of the cylinder, both in inches, and L the length of stroke in feet. In metric measures, kilogrammes and centimetres,

$$d_m = 1.3\sqrt[4]{d'^2 \rho L^2} + \frac{d'}{30}, \text{ nearly } \dots \dots (108)$$

The diameter may be more exactly obtained by a form of expression first proposed by Van Buren,* thus :

$$d = 0.006\sqrt{bP} \left(1 + .0008 \frac{l^2}{d^2} \right); \dots \dots (109)$$

or, when the ratio $\frac{l}{d}$ is given, thus :

$$d = a\sqrt{bP},$$

* *Strength of Iron Parts of Machinery* : New York, D. Van Nostrand, 1868.

in which a is a coefficient as below, b is the factor of safety, and P is the maximum pressure on the rod.

$\frac{l}{d} = 10$	$a = 0.0060.$
$\frac{l}{d} = 15$	$a = 0.0065.$
$\frac{l}{d} = 20$	$a = 0.0070.$

The value of $\frac{l}{d}$ is roughly estimated, and a readjustment made after the first calculation.

A lower factor of safety is, by some authorities, permitted in compression than in tension.

Connecting rods are treated as pillars with rounded ends, as are compression members of bridges with pin connections.

Piston rods and connecting rods may be calculated alike, using an expression of similar form, containing the diameter of the cylinder, D , and steam pressure, p . Thus:

$$d = aD\sqrt{bp} \quad (110)$$

in which may be taken

	$\frac{l}{d}$	a	b
CON. ROD :	10	0.00550	8
	15	0.00600	8
	20	0.00650	8
PISTON ROD :	10	0.00550	8
	15	0.00575	8
	20	0.00600	8

261. The Transverse Strength, or the resistance of any piece to bending, is determined by the longitudinal strength of the metal, both in tension and compression, by the form

of the piece, and by its absolute dimensions. When this method of stress affects a bar of iron or steel, there is called into action at every section a pair of forces resisting flexure, each acting about a "neutral line" at which the forces change sign. If a bar of iron is placed as shown in the illustration of the transverse testing machine (Art. 220), and if while supporting it at each end, the machine is made to apply a depressing force at the middle of the piece, the upper part of the bar is compressed, and the lower extended; while between these portions of strained metal is a plane of unstrained material, whose trace on the vertical plane is the neutral line. The moments of the forces by which the bar resists compression above and extension below this plane, together produce the measured resistance to flexure. The position of the neutral plane is determined by the relation existing between the magnitudes of the two forms of resistance; it may be considered as always at the middle of the section, within the elastic limit, while beyond that limit it approaches that side at which resistance is greatest at the moment. The total resistance to flexure, then, is measured by the sum of these two moments of resistance, which are themselves measured each by the product of the mean resistance of the strained parts of the most severely loaded cross section affected by it into its own lever arm.

By the ordinary theory, and its resulting equations, the resistances of particles to compression and to extension are taken proportional to their distance from the neutral surface; this is correct up to that limit of flexure at which the exterior sets of particles on the one side or on the other are forced beyond the elastic limit. With absolutely non-ductile materials, or materials destitute of viscosity, fracture occurs at this point; but, with ordinary materials, and notably with good iron, low steel, and all of the useful metals and alloys in common use, rupture does not then take place. The exterior portions of the mass are compressed on the one side, offering more and more resistance nearly, if not quite, up to the point of actual breaking, which breaking may only occur long after passing the elastic limit; on the other side, similar sets of

particles are drawn apart, passing the elastic limit for tension, and then resisting the stress with a more nearly constant force, "flow" occurring until the limit of that flow is reached, and rupture takes place.

Fracture thus may occur under either of several sets of conditions:

(1.) The material may be absolutely brittle. In this case the elastic limit and the limit of rupture coincide for both simple tension and simple compression. The piece will break with a snap when, under flexure, either limit is reached; or, as it may happen, when that limit is reached simultaneously on both sides at the instant of rupture.

(2.) The material may be slightly viscous. The flexure of the piece will produce compression or extension, or both, beyond the elastic limit before rupture occurs, giving three sets of conditions to be expressed by formulas. The increase of resistance, after passing the elastic limit, will not be the same for both forms of resistance, and each substance will probably be found characteristically distinguishable from every other.

It would appear from experiment that the resistance to compression will frequently increase with flexure in a very high ratio as compared with that to extension, thus swinging the neutral surface toward the compressed side, and with very hard and friable substances probably nearly to the limiting surface. This, probably, does not often happen with metals used in construction.

(3.) The material may be very ductile or viscous.* In this case the phenomena of flexure and rupture will be as last described, but of increased extent and importance. The resistances to extension and compression, as developed in this case, may be either approximately or accurately those observed in experiments producing rupture by direct tension and by direct compression. The neutral surface will be determined in position by the ratio of these ultimate resistances.

* Viscosity and high cohesive force may co-exist, as shown by Prof. Henry and Mon. H. Tresca.

No expressions have yet been derived by analysis, and constants determined by experiment, which enable the engineer to express by an equation the actual method of variation of internal resistances with variation of load and of deflection, for all materials; but sufficient accuracy is obtained for practical purposes in nearly all cases by treating the case in the simplest manner. Since the metals used in construction are rarely intended to yield beyond the elastic limit, it is usually sufficient to take the law found to exist within that limit as general for all actual deflections.

The resistance to ultimate rupture must follow a different law with all metals capable of flow, and of taking a set within the limit at which fracture takes place; since, in such cases, the resistance of any displaced particle is no longer proportional to its distance from the neutral plane and to the length of its lever arm, but is nearly or quite the maximum attainable in that material. Where pieces are short, also, the shearing stress produced by the load becomes too great to be neglected, and may even become the principal force acting to produce rupture; it is usually too small in beams and girders to be regarded.

262. Methods of Distribution of Resistances, in cases of flexure are exhibited in the accompanying figures.

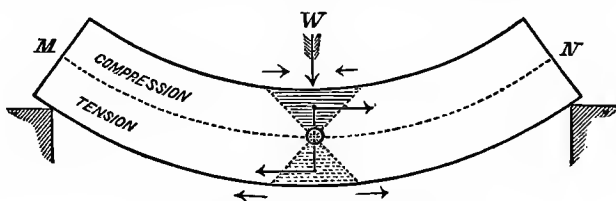

FIG. 86.—FLEXED ELASTIC BEAM.

In *MN*, the material being perfectly elastic up to the limit of flexure, the stress at any point is proportional to the area of the element strained, to the maximum elastic resistance of the material, and to the distance x of the element from the neutral plane *MON*. The resistance to flexure within the range of constant elasticity is therefore in this

case, as when the beam is ruptured, at that limit proportional to the breadth of the piece and to the square of the depth, where the section is rectangular.

Where a metallic beam is strained beyond the elastic limit at any part of its section, the stress outside that part is more nearly constant, and may become equal to the maximum resistance of the material, or

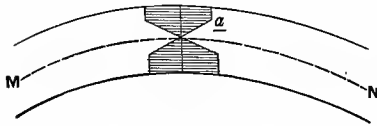

FIG. 87.

nearly so. Thus, in Fig. 87, the law of resistance changes at *a* and is no longer proportional to the distance of the strained particles from the neutral plane, but has the maximum possible value. This change may occur abruptly, as shown, or gradually, making the shaded parts exhibiting the magnitude of the stress, a pair of parabolas placed vertex to vertex. Finally, with all perfectly ductile materials, all parts of the section

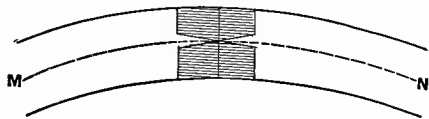

FIG. 88.

become equally strained, nearly as in Fig. 88, and we have the moment of resistance proportional to the breadth and to the square of the depth of the piece as before.

263. Theory of Rupture.*—In the usual case, in which the resistance to distortion varies from a maximum, *R*, at the outer surface to zero on the neutral plane, as in brittle materials, we have for the elementary area *dy dx*, for the resistance $\frac{R}{d_1} y$ per unit of area, and $\frac{R}{d_1} y dy dx$ on that area; while the moment of resistance, *M*, on that part of the whole section which lies on one side the neutral plane is obtained by integration from that line to the most strained fibre on either, at a distance, *d*₁, *R* being the “Modulus of Rupture”:

$$\frac{R}{d_1} \int_0^b \int_0^{d_1} y^2 dy dx = M \dots \dots (III)$$

* See Wood's “Resistance of Materials” for the Theory of Resistance.

i.e., the quotient of the modulus of rupture by the distance of the most strained fibre from the neutral line, multiplied by the moment of inertia.

When the resistance, after passing the elastic limit, becomes throughout—as sometimes may be nearly the case with ductile materials—equal to the maximum R , we have per unit of area, a resistance $R dy dx$, and for the moment

$$R \int_0^b \int_0^{d_1} y dy dx = M' \quad \quad (112)$$

For rectangular beams, when the neutral line may be taken at the middle of the section, as with non-ductile materials generally for the first, and for wrought iron frequently, or other substance having equal value of T and C , for the second case, we get, for the two cases respectively:

$$M = \frac{1}{8} R b d^2; \quad M^1 = \frac{1}{4} R b d^2 \quad \quad (113)$$

b being the breadth, and $d = 2d_1$ the total depth of section.

Thus, assuming the same value for ultimate resistance of cohesion, the ductile substance offers one half greater resistance than the non-ductile, and one half greater resistance just beyond than just within the elastic limit. Hence, also, it can only be expected that the value of R will coincide with the resistance to direct tension or direct compression in rare cases. The form of the strain diagram, as obtained by direct stress, should indicate the law of resistance to flexure, and furnish the forms of the functions and the values of constants needed for the correct theory of rupture. It is evident that the actual value of R may be compared with the values of T and C , to determine to what extent the case approaches that giving the second of these equations. Thus, the value of R for wrought iron, as determined under the first case, exceeds the value of T and C by one half, nearly, and this metal, therefore, falls under case second.

The first of these cases is that which it has been custom-

ary to assume as applicable in all cases. Its solution evidently gives results differing from the truth on the right side.

Examining equation (111), it is seen that the moment of resistance, M , is measured by the product of the "modulus" of rupture, R , into the quantity $\int \int y^2 dy dx$ divided by the depth d_1 to the neutral line, or, as shown by M. Navier, to the axis through the centre of gravity. The quantity $\int \int y^2 dy dx$, which is always a factor in this expression, is the moment of inertia, I , which has already been used in preceding articles.

It is evident that where, as is usual with metals, the material has different resisting powers in tension and compression, the areas on the opposite sides of the neutral axis may differ considerably, as, for example, in the case of cast iron, in which the resistance to crushing is several times as great as that offered to pulling stress. In such cases, the maximum resistance of the piece may be greatly increased by proportioning its section, as did Hodgkinson, with reference to this difference of resistances, extending the section laterally on the weaker side, and contracting it on the stronger.

The data to be here given are experimentally obtained figures, derived from tests of pieces of rectangular section; other forms will be considered later.

264. Formulas for Transverse Loading are deduced in all works on resistance of materials. For cases of rupture, when the beam is supported at the ends and loaded in the middle, for rectangular bars,

$$M = \frac{1}{4}Pl = \frac{1}{6}Rbd^2; \text{ and } R = \frac{3}{2} \frac{Pl}{bd^2}. \quad \dots \quad (114)$$

for non-ductile materials, and it may be assumed, in all cases in the engineer's practice, that the material tested is in practice either sufficiently elastic and rigid to justify the use of this formula, or is to be loaded only within its elastic limit. Then the formulas for other cases become:

(1.) Beam fixed at one end, load at the other:

$$Pl = \frac{1}{6}Rbd^2; \quad P = \frac{1}{6}R \frac{bd^2}{l} \dots \dots \dots (115)$$

(2.) Same, with load distributed uniformly :

$$\frac{1}{2} Wl = M ; \quad W = \frac{1}{3} R \frac{bd^2}{l} (116)$$

(3.) Beam supported at ends, loaded at middle :

$$\frac{1}{4} Pl = M ; \quad P = \frac{2}{3} R \frac{bd^2}{l} (117)$$

(4.) Same, uniformly loaded :

$$\frac{1}{8} Wl = M ; \quad W = \frac{4}{3} R \frac{bd^2}{l} (118)$$

(5.) Beam firmly fixed at ends, loaded at middle :

$$\frac{1}{8} Pl = M ; \quad P = \frac{4}{3} R \frac{bd^2}{l} (119)$$

Same determined by Barlow's experiments :

$$\frac{1}{6} Pl = M ; \quad P = R \frac{bd^2}{l} (120)$$

(6.) Same uniformly loaded :

$$\frac{1}{12} Wl = M ; \quad W = 2R \frac{bd^2}{l} (121)$$

(7.) Fixed at one end, supported at the other, load at the middle :

$$\frac{1}{8} Pl = M ; \quad P = \frac{4}{3} R \frac{bd^2}{l} (122)$$

All of these equations are, of course, "homogeneous."

Replacing bd^2 by $0.59d^3$, transforms these equations so as to apply very exactly to circular sections.

265. The Modulus of Rupture, R , being obtained by experiment and inserted in these formulas, the maximum load that a beam will support, when of similar shape and of that material, becomes calculable.

The value of the modulus of rupture is readily determined by experiment from the formula :

$$R = \frac{3}{2} \frac{l}{bd^2} (P + \frac{1}{2}W) \dots \dots (123)$$

when the weight of the beam, W , is taken. When the dimensions all become unity, we have, neglecting W ,

$$R = \frac{3}{2}P;$$

that is to say, the modulus of rupture is one and a half times the load which would break a bar unity in length, breadth and depth, supported at the ends and loaded in the middle. For British measures, it is 18 times the weight that would break a bar so loaded if one foot long, and one inch square in section.

Very ductile bars bend without breaking. The correct modulus of rupture in these cases, therefore, cannot be determined, and it is necessary to assume a given amount of bending as equivalent to breaking the bar or rendering it useless, and the modulus of rupture is calculated from the load causing this maximum deflection, to afford a means of comparing the transverse strengths of all bars which were tested.

The Limit of Elasticity is taken to be the point at which the deflections begin (usually suddenly) to increase in a greater ratio than the applied loads, and in the plotted curves of deflections it is the point at which the curve begins to diverge from its original and nearly vertical direction and becomes more nearly horizontal.

This point is not always clearly defined, and it is often difficult to fix its exact position.

The limit of elasticity coincides in some, though not in all, cases with the first observed set, or point at which the bar under test exhibits a deflection after the load is removed.

The point of "first appreciable set" given in some tables

is taken as a set of 0.01 inch, which is an amount much beyond the common limits of errors of observation.

For the purpose of comparing the resistances of the different bars to stress at the elastic limit and at the first appreciable set, with their resistances at the point of final rupture, values of

$$R_1 = \frac{3}{2} \frac{P_1 l}{bd^2}$$

are sometimes taken by the Author, in which P_1 is the load corresponding to the limit of elasticity or to appreciable set.

The value of R for iron and steel, exhibits the same variations with composition and structure that have been observed in test by longitudinal stress. A common expression for the strength of rectangular wrought-iron bars, supported at the ends and loaded in the middle, is

$$P = 26 \frac{bd^2}{l} \dots \dots \dots (124)$$

in tons, the measures being taken in inches. This would reduce to

$$P = \frac{2}{3} R \frac{bd^2}{l} = 58,240 \frac{bd^2}{l} \dots \dots \dots (125)$$

$$P_m = 4,100 \frac{b_m d_m^2}{l_m}, \quad \text{and } R = 87,360, \quad R_m = 6,150,$$

metric measures being indicated by the subscript m . This value greatly exceeds that of either T or C , and it is thus proved that this metal belongs to the ductile class of Article 263, and that its condition when, at the point of rupture, approximates to that covered by equation (112).

Good wrought iron should have a value of R not far from 80,000 where the measures are taken as above in inches and pounds, or about 5,600 for metric measures. Steel exhibits a nearly constant value of R for all grades, from 0.3 to 1 per cent. carbon, when it is made of equally good material. Bauschinger found the value of the modulus of rupture in metric measures to vary irregularly in steels containing

from 0.14 to 0.96 per cent. carbon, the maximum obtained being 9,600 when $C = 0.57$, and the minimum 7,645 when $C = 0.80$. No law seemed to govern the variation; $R_m = 8,500$ would seem to be a good general value for the steels tested, giving $R = 120,000$, nearly, for British measures.

The cast irons exhibit a very great variation in power of resisting bending stress. The strengthening influence of combined carbon, silicon, phosphorus, and manganese, and the weakening effect of silica and graphitic carbon, and of defects of structure, produce differences that are much greater than those met with in the malleable metals.

The following are results of tests made upon samples of good No. 2 and No. 4 cast irons; the average is given of several tests made for the Author, as on pages 441, 460:

TABLE LXXXIX.
TRANSVERSE RESISTANCE OF CAST IRON.

SAMPLES.	ELASTIC RESISTANCE.		DEFLECTIONS.	
	Load lbs.	Load kilogs.	Inches.	Centimetres.
No. 2.....	320	145.45	0.0789	0.20
No. 4.....	600	272.72	0.11066	0.28

SAMPLES.	ULTIMATE RESISTANCE.		MAXIMUM DEFLECTION.	
	Lbs.	Kilogs.	Inches.	Centimetres.
No. 2.....	1,383	629.09	0.5340	1.36
No. 4.....	2,060	936.4	0.5017	1.27

Bars, 22" × 1" × 1".

The moduli of rupture are therefore 45,740 and 67,980 in British measures, and 3,260 and 4,790 in metric; the section of the bar being one square inch (2.54 centimetres square), and the length between supports 22 inches (55.9 centimetres).

The correspondence noted in these values with the mean of those obtained for T and C would seem to indicate that the equation usually taken applies fairly to cast iron.

266. **Sections Other than Rectangular** are most common in iron and steel beams and girders. For the general case we have, as already shown, for moderate deflections :

$$M = \frac{RI}{y_1} (126)$$

where M is the moment of resistance to bending offered by the beam ; I is the Geometrical Moment of Inertia of the strained section, and y_1 is the distance of the neutral axis of the beam from the adjacent surface, when either tension or compression acts alone to produce M . When the neutral axis is at the middle of the section, and the resistances are equal above and below, the *total* moment of resistance becomes,

$$M = 4 R \frac{I}{d} (127)$$

d being the depth of the strained section.

Prof. C. A. Smith gives a simple, handy rule for the moment of resistance of sections of "tee" and "angle" irons exposed to flexure, thus :*

One-fourth the product of breadth, depth, and thickness of flange, in inches, is the moment of resistance in foot-tons ; *i. e.*,

$$\frac{bdt}{4} = M \text{ nearly.}$$

In metric measures, the divisor becomes 200 to give the moment in metre-tonnes.

The quantity thus obtained being taken as the working load, the maximum stress is about 10,000 pounds per square inch (703 kilogrammes per square centimetre).

The values of R given in the tables are not exact for

* *Railroad Gazette*, Nov. 13, 1875.

beams and girders of other than rectangular section, or for cases in which the neutral axis shifts its position under the load. If the value of R is taken as equal to the smaller of the two values T and C , any error will be on the safe side; or the factor of safety may be somewhat increased to allow for an overestimate.

The forms of section adopted will be seen in Article 270, on the working formulas for beams. It is evident that, in general, extending the extreme portions of the section where stresses become greatest, and restricting the intermediate part, or the "web," to the size needed to hold the other portions in proper relative positions, will produce forms of beam of greater strength, with a given weight of material, than can be obtained in the cases of rectangular, circular, or other simple forms of section.

Where the metal has equal strength to resist tension and compression, it is further evident that the top and bottom "flanges" should be of equal size; this constitutes the Tredgold "I-beam" usually made in wrought iron. When the metal is stronger in compression than in tension, as is the case with cast iron, the extended side should be enlarged; this was done by James Watt when making his "L-beam," and by Fairbairn and Hodgkinson, who first made the "I-beam," in which the compressed flange has an area less than that under tension in the same proportion that the resistance to compression exceeds the resistance to tension. For ordinary cast iron these areas are as six to one.

In many cases the form of section is determined by convenience in making or in building up. Beams and columns are often constructed of L, or "angle" iron, with plate iron, or with \sqcup , or "channel" iron, built up in various ways to form I-beams, Ξ -beams, or various sections approaching hexagonal or circular.

For all such cases the moment of inertia can be determined and inserted in the general formulas.

The transverse strength of "round iron" and steel of circular section may be taken as six-tenths the strength of bars of square section having their sides equal to the diam-

eter of the former. A hollow cylinder has a strength exceeding that of a solid cylinder of the same length, weight and volume. Triangular beams of cast iron are strongest when the edge resists compression, and their resistance becomes a maximum when the shape of section and the ratio of tensile strength to resistance in compression are so related that the beam, when at the point of rupture, is equally liable to break by yielding to either force.

267. Beams of Uniform Strength and Minimum Dimensions.—The following illustrations exhibit the forms of beams of uniform strength from end to end.

A beam fixed at one end, loaded at the other, as in

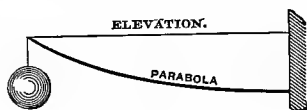

FIG. 89.

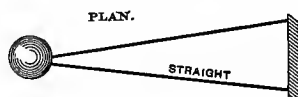

FIG. 90.

Fig. 89, if of uniform thickness horizontally, is a parabola in elevation, the vertex of the curve at the loaded end, and bd^2 is proportional to distance from that end. When of uniform depth, as in Fig. 90, the plan is triangular and the value of bd^2 as before. If carrying a uniformly distributed load,

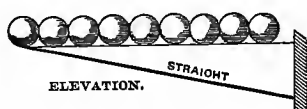

FIG. 91

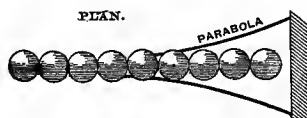

FIG. 92.

Fig. 91, the elevation is a triangle with apex at the outer end, if of uniform thickness; while if of uniform depth, Fig. 92, the plan becomes a pair of parabolas, as shown, making db^2 proportional to square of the distance from the point.

Beams supported at both ends and loaded in the middle, if of uniform thickness, Fig. 93, are a pair of parabolas in elevation, with vertices at the ends, and $bd^2 \propto$ distance from

the nearer support. When of uniform depth, Fig. 94, the plan is a pair of triangles, base to base, making bd^2 as above.

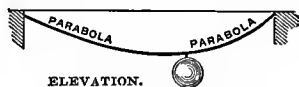

FIG. 93.



FIG. 94.

When uniformly loaded from end to end, Fig. 95, when of uniform depth the plan is a pair of parabolas with vertices at the middle of the beam ; while $bd^2 \propto$ product of the dis-



FIG. 95.

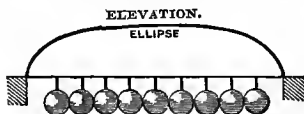

FIG. 96.

tances to the ends. If of uniform thickness horizontally, Fig. 96, the elevation is a semi-ellipse with bd^2 as before.

268. The Theory of Elastic Resistance, as generally accepted, is as follows :

In figure 97, which represents a longitudinal section through a loaded beam, let EF be the neutral line extending throughout its length. Let AB and CD be consecutive transverse sections separated by the distance dx ; $C'D'$ is the position of C when swung out of its original place by the action of the load W , and its intersection with the plane AB is found at R . Then, ab being the original length of any fibre at a distance $Ob = y_1$ from the neutral axis, $bc = \lambda$ will be its elongation, and if the radius of curvature, OR , is called ρ , we have

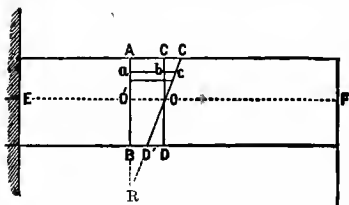

FIG. 97.

$$\lambda = \frac{y dx}{\rho} (128)$$

and the stress on any fibre of the area, $a = dy dz$, will be

$$p = Ea \frac{\lambda}{dx} = \frac{E}{\rho} y dy dz. \quad \dots \quad (129)$$

and the moment about the intersection with the neutral line is

$$py = \frac{E}{\rho} y^2 dy dz, \quad \dots \quad (130)$$

accordingly as the fibre is above or below that line.

The total moment will be

$$M = \frac{E}{\rho} \int_0^b \int_0^{d_1} y^2 dy dz + \frac{E}{\rho} \int_0^b \int_0^{d_2} y^2 dy dz. \quad \dots \quad (131)$$

For cases in which the section is symmetrical about the neutral line,

$$M = \frac{EI}{\rho} = \frac{E}{\rho} \int_0^b \int_{-\frac{1}{2}d}^{+\frac{1}{2}d} y^2 dy dz. \quad \dots \quad (132)$$

in which integrals b is the breadth of section, d_1 and d_2 are the depth of the half sections above and below EF , and d is the total depth. Also,

$$M = \frac{EI}{\rho}. \quad \dots \quad (133)$$

The value of ρ , the radius of curvature, is shown in works on the differential calculus to be

$$\rho = \pm \frac{\left(1 + \frac{dy^2}{dx^2}\right)^{\frac{3}{2}}}{\frac{d^2y}{dx^2}};$$

which value reduces the equation for $M = Pl$, as in Fig. 97, to

$$Pl = M = EI \frac{d^2y}{dx^2}. \quad \dots \quad (134)$$

when $\frac{dy^2}{dx^2}$ may, as is probably usually the case, be neglected.

Inserting the value of M in terms of x , we have, for example, with the "cantilever," or beam fixed at one end, loaded at the other, origin at the end :

$$(l-x)P = EI \frac{d^2y}{dx^2},$$

which, being integrated once, gives

$$\frac{dy}{dx} = \frac{P}{2EI} (2lx - x^2) + C.$$

When $x = 0$, $\frac{dy}{dx} = 0$, and $C = 0$.

Again integrating, and

$$y = \frac{P}{6EI} (3lx^2 - x^3) + C,$$

in which, where $x = 0$, $y = 0$ and $C = 0$, and the value for deflection at $x = l$, for this case is

$$D = \frac{1}{3} \frac{Pl^3}{EI},$$

as already given.

For uniform loading,

$$\frac{d^2y}{dx^2} = \frac{w}{2EI} (l-x)^2,$$

and

$$D = \frac{wl^4}{8EI}; \text{ etc.}$$

All usual cases are developed in treatises on the theory of the resistance of materials.

The elastic resistance to flexure is of greater importance in very many cases than the ultimate transverse strength, as

pieces are in machinery almost invariably, and in other structures usually rendered useless when the change of form exceeds a limit which is generally intended to be well within the elastic range.

The deflection of any piece of rectangular section is readily determined under the conditions usually assumed.

The formula for deflection of long bars tested by transverse stress, within the elastic limit, is

$$D = \left(P + \frac{5}{8} W \right) \frac{l^3}{4Ebd^3} \dots \dots (135)$$

where D is the deflection, P the applied load, W the weight of the bar between supports, E the coefficient (or, as generally termed, the modulus) of elasticity, l , b , and d the length between supports, breadth, and depth of the bar. The value of E found by tests by tensile stress is not always exactly the same as that obtained by transverse tests of long bars.

The formula just given for deflection of bars tested by transverse stress, viz. :

$$D = \frac{Pl^3}{4Ebd^3},$$

is not quite accurate, as it neglects the deflection due to shearing stress, which varies directly as the load. The true formula (the weight of the bar itself not being considered) is

$$D = \frac{Pl^3}{4Ebd^3} + \frac{3}{8} \frac{Pl}{E_s bd} \dots \dots (136)$$

in which E_s is the coefficient of elastic resistance to shearing.

In tests made by the Author, l , in general, is 22 inches; b and d are each one inch. The formula then reduces approximately to

$$D = \frac{2662P}{E} + \frac{33P}{4E_s}.$$

The value of E_s is often about $\frac{2}{3} E$, which would make the last term of the above equation

$$\frac{5 \times 33}{2 \times 4E} = \frac{20}{E} \text{ (nearly);}$$

a small fraction of the first term of the second member of the equation. The resistance to shearing may therefore be neglected in calculating the modulus of elasticity from such transverse tests of bars, as the error introduced is less than one-tenth of one per cent.

Whence,

$$E = \frac{l^3}{4Dbd^3} \left(P + \frac{5}{8} W \right),$$

from which latter formula the moduli of elasticity given in the tables are calculated.

It will be observed in experiments that, in many of them, especially in tests of the stronger metals, the modulus of elasticity increases slightly at the beginning of the test, then remains nearly constant for a certain distance, or slowly approaches a maximum, and then, at first slowly, and afterward very rapidly, decreases to the breaking point. This corresponds with what is shown in the plotted curve of deflections, viz., the beginning of the curve sometimes shows a slight curvature convex to the axis of abscissas, then a straight line slightly inclined from the vertical. The inclination from the vertical then increases, at first slowly and afterward more rapidly, till the curve takes a more nearly horizontal direction.

In some of the tables, the figures in the column headed "Modulus of Elasticity," are those which are considered the *most probable* moduli within the elastic limit, or which most nearly represent the relation between the stresses and the distortions within that limit. In most cases the maximum modulus is selected, unless the deflection corresponding to the maximum is so small a quantity as to render the probable error of the observation a large portion of the apparent deflection.

In a few instances the apparent modulus at the beginning of the test is much smaller than it soon afterward becomes;

and this indicates either a possible error or the existence of internal stress at this part of the test. The moduli should therefore be determined by rejecting the deflections at the beginning of the test, and taking the ratio of distortion to stress at a point where this ratio becomes sensibly constant.

The value of E has been already given. It usually varies but little with variation of composition, except in the cast irons, where it is lessened by presence of graphitic carbon.

In general, we have, within the elastic limit,

$$D = \frac{1}{3} \frac{Pl^3}{EI}; \quad P = \frac{3DEI}{l^3} \quad \dots \quad (137)$$

for the case of a beam fixed at one end and loaded at the other:

When uniformly loaded,

$$D = \frac{1}{8} \frac{Wl^3}{EI}; \quad W = \frac{8DEI}{l^3} \quad \dots \quad (138)$$

For beams supported at the ends, these equations for single and distributed loads are

$$D = \frac{1}{48} \frac{Pl^3}{EI}; \quad P = \frac{48DEI}{l^3} \quad \dots \quad (139)$$

$$D = \frac{1}{75} \frac{Wl^3}{EI}, \text{ nearly}; \quad W = \frac{75DEI}{l^3} \quad \dots \quad (140)$$

For beams fixed at the ends, we have

$$D = \frac{1}{200} \frac{Pl^3}{EI}, \text{ nearly}; \quad P = \frac{200DEI}{l^3} \quad \dots \quad (141)$$

$$D = \frac{1}{400} \frac{Wl^3}{EI}, \text{ nearly}; \quad W = \frac{400DEI}{l^3} \quad \dots \quad (142)$$

For rectangular beams,

$$I = \frac{1}{12} bd^3,$$

and we may write the simplified formula for a beam supported at the ends and loaded in the middle,

$$D = \frac{CPl^3}{bd^3} \dots \dots \dots (143)$$

For a beam fixed at one end and loaded at the other,

$$D = \frac{16CPl^3}{bd^3} \dots \dots \dots (144)$$

and, when uniformly loaded, the two cases give

$$D = \frac{5}{8} \frac{CWl^3}{bd^3}$$

and

$$D = \frac{6CWl^3}{bd^3} \dots \dots \dots (145)$$

Where the length is measured in inches,

$$C = \frac{1}{4E}, \text{ and when in feet, } C = \frac{1728}{4E}.$$

For the two cases it will be safe to take $E = 25,000,000$, and $C = 0.00000001$, and $C = 0.000017$, respectively, for iron.

For steel, which is a little stiffer, take $E = 29,000,000$, and $C = 0.000000008$, or $C = 0.000015$.

269. Results of Experience.—But little has been done experimentally to determine the flexure of metal beams of large sections.

The Phoenix Iron Company find their experience accordant with the approximate working formulas for I-shaped floor-beams and girders carrying uniformly distributed loads,

$$W = \frac{2}{3} d \left(a + \frac{1}{6} a_1 \right) \frac{T}{L} \dots \dots \dots (146)$$

$$D = \frac{0.004WL^3}{\left(a + \frac{1}{6} a_1 \right) d^3} \dots \dots \dots (147)$$

in which W is the distributed load in *tons* of 2,000 pounds, L the span in feet, a the area of one flange-section, a_1 that of web-section, d distance between centres of gravity of flanges in inches, T the tenacity per square inch of section, D the deflection of the beam in inches* under a load at the middle, D_1 the same under a distributed load.

The formula for W is thus derived: the top and bottom flanges will resist with a moment,

$$2T(a \times \frac{1}{2}d) = adT;$$

the moment of the web-resistance is

$$\frac{2}{3}T \cdot \frac{1}{2} \cdot d \cdot \frac{1}{2}a_1 = \frac{1}{6}a_1dT, \text{ nearly,}$$

and the total moment is

$$(a + \frac{1}{6}a_1)dT = \frac{1}{8}Wl = \frac{3}{8}WL,$$

$$\therefore W = \frac{2}{3} \frac{d(a + \frac{1}{6}a_1)T}{L}, \text{ nearly.}$$

The formula for D is obtained by substituting the approximate value of

$$I = \frac{1}{12}d^2(6a + a_1),$$

in the formula already given for deflection.

Deflection is usually limited to between 0.03 and 0.025 inch per foot length of girder, *i. e.*, from 0.0025 to 0.002 of total length between supports.

For a load in the middle, the deflection is

$$D_1 = \frac{0.006PL^3}{d^2(a + \frac{1}{6}a_1)} \dots \dots \dots (148)$$

* The trade circulars and pocket-books issued by reputable makers may be referred to for tables of values of W and D .

The following are the published data on which the above formulas are based :

TABLE XC.—TESTS OF W. I. BEAMS.

7 INCH BEAM. 60 LBS. PER YD. AREA 6 SQ. IN. CLEAR SPAN 21 FEET.				9 INCH BEAM. 87 LBS. PER YD. AREA 8.7 SQ. IN. CLEAR SPAN 21 FEET.				9 INCH BEAM. 150 LBS. PER YD. AREA 15 SQ. IN. CLEAR SPAN 14 FEET.			
Centre load, in lbs.	Deflection, inches.	Increase, inches.	Remarks.	Centre load, in lbs.	Deflection, inches.	Increase, inches.	Remarks.	Centre load, in lbs.	Deflection, inches.	Increase, inches.	Remarks.
2,000	0.468			2,000	0.228			5,608	0.102		
3,000	0.743	0.275		4,000	0.474	0.246	*	6,720	0.126	0.024	
4,000	1.020	0.277		6,000	0.720	0.246		7,840	0.148	0.022	
5,000	1.298	0.278		8,000	0.962	0.242		8,960	0.170	0.022	
	0.029	Perm. set.	Wt. rem'd.	10,000	1.201	0.239		10,080	0.192	0.022	
6,000	1.578	0.280			0.048	Perm. set.	Wt. rem'd.	11,200	0.214	0.022	
	0.030	Perm. set.	Wt. rem'd.	12,000	1.432	0.231		12,320	0.239	0.025	
7,000	1.887	0.309			0.050	Perm. set.	Wt. rem'd.	13,440	0.261	0.022	
	0.060	Perm. set.	Wt. rem'd.	13,000	1.580	0.148		14,560	0.287	0.026	
8,000	2.300	0.413			0.117	Perm. set.	Wt. rem'd.	15,680	0.310	0.023	
	0.183	Perm. set.	Wt. rem'd.	14,000	1.863	0.283		16,800	0.336	0.026	
9,000	3.540	1.240			0.269	Perm. set.	Wt. rem'd.	17,920	0.359	0.023	
9,500	5.298	1.758		16,000	3.256	1.393		19,040	0.382	0.023	
			Beams sunk slowly, top flange yield'g.	17,000	5.233	1.977		20,160	0.409	0.027	
10,000							Side deflection begins. Beam yields slowly at this load.	21,280	0.435	0.026	
				17,500	5.602	0.369		22,400	0.458	0.023	
								23,520	0.487	0.029	
								24,640	0.516	0.029	
								25,760	0.543	0.027	
								26,880	0.572	0.029	
								28,000	0.600	0.038	
								29,120	0.633	0.033	Load left stand 1 hour.
								29,120	0.682	0.049	Wt. off.
								0.082	Perm. set.		

12 INCH BEAM. 125 LBS. PER YARD. AREA 12 1/2 SQUARE INCHES. CLEAR SPAN 27 FEET.

13 INCH BEAM. 155 LBS. PER YARD. AREA 15 1/2 SQUARE INCHES. CLEAR SPAN 27 FEET.

15 INCH BEAM. 200 LBS. PER YARD. AREA 20 SQUARE INCHES. CLEAR SPAN 14 FEET.

Centre load, in lbs.	Deflection, inches.	Increase, inches.	Centre load, in lbs.	Deflection, inches.	Increase, inches.	Centre load.		Deflection, inches.	Increase, inches.
						In Lbs.	Tons.		
6,720	0.691	0.130	6,720	0.342	0.060	6,720	3	0.048	
7,840	0.821	0.127	7,840	0.402	0.060	8,060	4	0.060	0.012
8,960	0.948	0.113	8,960	0.462	0.061	11,200	5	0.073	0.013
10,080	1.067	0.125	10,080	0.523	0.057	13,440	6	0.090	0.017
11,200	1.186	0.142	11,200	0.580	0.059	15,680	7	0.105	0.015
12,320	1.328	0.138	12,320	0.639	0.068	17,920	8	0.120	0.015
13,440	1.466	0.104	13,440	0.707	0.071	20,160	9	0.134	0.014
14,560	1.630	0.170	14,560	0.778	0.067	22,400	10	0.148	0.014
15,680	1.800	0.176	15,680	0.845	0.068	24,640	11	0.161	0.013
16,800	1.976	0.252	16,800	0.913	0.079	26,880	12	0.178	0.017
17,920	2.228	0.227	17,920	0.992	0.071	29,120	13	0.191	0.013
19,040	2.455	0.287	19,040	1.063	0.086	31,360	14	0.206	0.015
20,160	2.742	0.290	20,160	1.140	0.160	33,600	15	0.222	0.016
20,720	2.900	0.158	22,400	1.300	0.196	35,840	16	0.234	0.012
20,720	2.965	0.065	24,640	1.505	0.258	38,080	17	0.246	0.012
			25,760	1.603	0.078	40,320	18	0.258	0.012
						42,600	19	0.271	0.015
						44,800	20	0.287	0.016
						47,040	21	0.305	0.018

Last load left on fifteen minutes. Deflection increasing to 2.965.

Load removed. Deflection decreased to 0.261 permanent set after lapse of half an hour.

Weight removed. Permanent set 0.016. After lapse of one hour the load of 15 tons was replaced, and caused a total deflection of 0.222 inches as before.

Steel Springs.—Mr. D. K. Clark found the deflection of locomotive and other railway springs to be

$$D = \frac{1.66s}{nbt^3} \dots \dots \dots (149)$$

and the working load to be

$$P = \frac{nbt^3}{11.3s} \dots \dots \dots (150)$$

when n = the number of plates in the spring, s = the span ; b and t = the breadth in inches and thickness in sixteenths ; D = the deflection in sixteenths of an inch ; and P = the load in tons.

270. Working Values for Beams.—A series of values for general use has been tabulated by Haswell,* as below, in British measures, after careful comparison with the results of experience, and of experimental investigation.

Such tables are in constant use among engineers, and formulas are usually reduced to these simpler forms for daily office work.















Office hand-books are in use in every profession, in which all the data, tables, and useful matter relating to daily routine work are compactly placed. Such hand-books, rather than a work of the character of that here presented, are consulted for information of this character. It can only be very concisely summarized here as illustrating the principles stated, and as exhibiting the more usual cases. All makers of repute furnish all required data for use in proportioning work in which peculiar shapes or special sizes are to be adopted.

It is not usual to design steel beams and angles for a fibre stress of 16,000 pounds per square inch, a shearing stress of 10,000, and a bearing load on rivets or bolts of 20,000.

* Haswell's *Pocket Book*. See also Trautwine's *Pocket Book* for working formulas and constants for office use; also Kent's *Pocket Book for M. E.*

TABLE XCI.—STRENGTH OF CAST-IRON BEAMS.





Beam supported at both ends; weight applied in the middle.

SECTION OF GIRDER OR BEAM.	FLANGES.		WIDTH OF VERTI- CAL WEB.	DEPTH OF GIRDER.	BREADTH OF GIR- DER.	AREA OF SECTION IN CENTRE.	BREAKING WEIGHT AT LENGTH OF ONE FOOT.	STRENGTH PER SQ. IN. OF SECTION.	CONSTANT C. $P = C \frac{Ad}{L} \dagger$
	Top.	Bottom.							
 Eq. area of flange at top and bottom.	Sq. ins. $1.75 \times 0.42 = 0.735$	Sq. ins. $1.77 \times 0.39 = 0.69$	0.29	5.125	1.77	2.82	30,150	10,768	2,100
 do.	$2.02 \times 0.515 = 1.045$	$2.02 \times 0.515 = 1.045$	0.51*	2.02	2.02	2.59	10,276	3,952	1,900
 Area of section of top and bottom, 1 to 6.	$2.23 \times 0.31 = 0.72$	$6.67 \times 0.66 = 4.4$	0.266	5.125	6.67	6.23	117,450	18,852	3,650
 —	—	$5 \times 0.3 = 1.5$	0.365	1.56	5.	1.96	7,280	3,714	2,350
 —	—	$23.9 \times 3.12 = 74.56$	3.3	36.1	23.9	183.5	8,066,240	43,958	1,200
 —	$0.5 \times 0.5 = 0.25$	$1.5 \times 0.5 = 0.75$	0.5	4.†	1.5	1.	19,980	19,980	5,000
 —	$1.5 \times 0.5 = 0.75$	$0.5 \times 0.5 = 0.25$	0.5	4.†	1.5	1.	7,252	7,252	1,800
 —	$4 \times 2 = 8$	—	2.	4.	4.	12.	33,600	2,800	700
 —	$5.1 \times 2.33 = 11.88$	$12.1 \times 2.07 = 25.04$	2.08	30.5	11.1	90.8	4,793,800	52,795	1,700
 Rectangular Prism.	—	—	0.994	2.012	2.994	2.025	9,440	4,662	2,350
 Open Beam.	1.005×0.98 0.995×1.01 1.005×0.98	1.005×0.99 $0.995 \times 1.$ 1.005×0.98	1.005 0.995 1.005	2.51 3.01 0.4	1.005 0.995 1.005	1.98 2. 1.98	12,340 15,420 21,765	6,232 7,710 10,992	2,450 2,550 2,700
 —	0.771×1.51 1.507×0.74 1.525×0.78	0.771×1.51 1.507×0.74 1.525×0.78	0.771 1.507 1.525	4.04 4.04 4.07	0.771 1.507 1.525	2.322 2.23 2.35	25,705 25,735 30,000	11,070 11,540 12,689	2,750 2,850 3,100
 Square Prism, Stress at Side.	—	—	1.02	1.01	1.02	1.032	2,635	2,552	2,500
 Cylinder.	—	—	1.122	1.122	1.122	0.989	2,370	2,396	2,150
 Square Prism, angle up.	—	—	0.443†	1.443	1.443	1.041	2,269	2,182	1,500

* Horizontal web. † Depth of opening, 3 inches. ‡ A area of section, d depth in inches, L the length in feet, and P the breaking weight in pounds.

TABLE XCII.—STRENGTH OF W. I. BEAMS.

Beam supported at both ends; weight applied in the middle.











SECTION OF GIRDER OR BEAM.	FLANGES.		WIDTH OF VERTICAL WEB.	DEPTH OF GIRDER.	BREADTH OF GIRDER.	AREA OF SECTION IN CENTRE.	BREAKING WEIGHT AT LENGTH OF ONE FOOT.	STRENGTH PER SQ. INCH OF SECTION.	CONSTANT C. $P = C \frac{Ad}{L}$
	Top.	Bottom.							
	Sq. Ins.	Sq. Ins.	Inch.	Inch.	Inch.	Sq. in.	Lbs.	Lbs.	Lbs.
 Solid,	2.5 × 1 = 2.5	4 × .38 = 1.52	.325	8.38	4.	6.295	132,000	20,952	2,500
"	2.85 × .38 = 1.08	—	.31	2.5	2.85	1.73	12,560	7,260	2,900
"	—	2.85 × .38 = 1.08	.31	2.5	2.85	1.73	12,032	6,955	2,750
"	—	3.5 × .6 = 2.1	.8	3.5	3.5	6.25	49,280	7,822	2,200
 Riv'd,	2.86 × .33 = .944	2.86 × .33 = .934	.66	3.7	2.86	3.88	56,000	14,433	3,800
"	5 × .25 = 1.25 2 of 2.25 × .3 = 2.82	—	.54	2.6	5.	4.07	23,485	5,770	2,250
"	2 of 3.5 × 3.5 × .5 = 7 2 of 2.125 × .28 = 1.19	2 of 3.5 × 3.5 × .5 = 7 2 of 2.125 × .30 × 1.29	.37	16.	7.37	19.02	768,000	38,593	2,400
"	—	—	.25	7.	4.5	4.26	170,660	40,345	5,800
"	—	—	Thick. of Plates.	5.8	3.8	1.24	23,670	14,089	3,200
"	—	—	.065	3.	1.95	.6	9,450	13,750	5,200
"	—	—	.1325	6.	4.	2.62	75,600	28,855	4,700
"	—	—	.124	24.	15.	9.6	375,000	39,063	1,600
"	—	—	.272	23.75	15.5	21.2	1,530,000	72,452	3,000
"	—	—	.525	24.	16.	41.45	3,864,000	93,221	3,900
"	—	—	.75	36.	24.	87.75	4,310,400	149,333	4,900
"	9.6 × .252 = 2.419	9.6 × .075 = .72	.074	9.5	9.5	4.36	146,528	33,607	3,450
"	9.26 × .149 = 1.378	9.25 × .269 = 2.488	.059	18.25	9.25	6.03	119,210	19,768	1,050
"	2.25 × .26 = .585	2.25 × .26 = .585	.131	15.	2.25	5.1	452,400	88,706	5,500
"	1 × .282 = .282	1 × .116 = .116	.067	8.	1.	1.47	123,794	84,214	10,300
"	24.*	128	—	54.	2.92	45.82	9,443,400	206,096	3,800
 Ellip. †	—	—	.375 t. .25 b. .125 s. .143	24.	16.	12.94	188,160	14,540	6,050
"	—	—	.143	15.	9.75	5.56	278,250	50,045	3,300
 Tubes,	—	—	.0408	12.	12.	1.4	44,200	31,571	2,600
"	—	—	.005	24.	24.	7.13	298,629	41,743	1,725

* Thickness of plates, bottom, .156; top, .147; sides, .099. Area of bottom, 8.8 inches.

† The lateral strength was ascertained to be 38,080, or .613 of its vertical strength. The ultimate deflection was 3/4 inches.

TABLE XCIII.—DEFLECTION OF BEAMS OF VARIOUS SECTIONS.

Beams supported at both ends; weight applied in the middle.

MATERIAL AND SECTION.	LENGTH OF BEARING.		BREADTH.	DEPTH.	DEPTH OF OPENING.	WEIGHT.	DEFLECTION.	CONSTANT, C.
	Ft.	Inch.	Inch.	Inch.	Inch.	Lbs.	Inch.	$P = 16CD \frac{bd^3}{P}$
Metals.								Lbs.
Cast iron, English.....	2	10	1.	1.	—	300	.16†	2,660
“ “ dry sand, square.	1	8	2.	2.	—	10,800	.11	1,756
“ “ green sand, “	1	8	2.	2.	—	5,000	.045†	1,988
 Flange, 5 × 3 ...	6	6	.36	1.55	—	112	.273	5,302
	6	6	.36	1.55	—	336	1.03	4,203
 Flange, 1.5 × .5...	6	6	.36	1.55	—	112	.27	5,303
	6	6	.36	1.55	—	336	.895	4,837
 Flange, 23.9 × 3.125 6.5 × 1 area 18	23	1	3.29	36.1	—	60,000	1.	2,986
	15		.91	14.	—	4,480	.3	1,261
 “ 4.5 × .875 9 × 1.25	22		1.12	36.	—	22,400	.094	3,035
 Rectangular, area 1.965	4	6	.975	2.015	—	712	.28	1,815
 Open beam area 2	4	6	1.	2.5	.5	712	.132	1,969
Wrought iron.								
Square.....	2	9	2.	2.	—	2,240	.068	2,678
Rectangle.....	2	9	1.5	3.	—	2,240	.074	971
 Flange, 4.5 × .5 Rib, 3.25 diameter,	10	3	.5	10.	—	3,136	.375†	1,126
 Flanges, 2 of 2.25 × .28 2.25 × .3	7		.25	7.	—	16,480	.25	16,480
 Tubes, thickness .03 in. } .525 “ }	3	9	1.9	3.	—	448	.1	289
	30		15.5	24.	—	5,685	.12	373
 Tubes, thickness .037 in. }	17		12.	12.	11.925	2,755	.65*	—
Corrugated plates.....	31	6	3.1	8.	—	4,480	.62	8,893
 Tubes, thickness .0416 in. } .143 “ }	17		9.25	14.62	13.535	2,262	.62*	—
	17		9.75	15.	14.714	16,800	1.39*	—
Steel, cast, soft.....	3	2	.23	.52	—	22	.331	4,107
Brass, cast.....	1		.7	.45	—	60	.04†	1,488

* Breaking weight.

† Elasticity perfect.

‡ Permanent set.

271. Tables of Rolled Girders.—The elements required in the proportioning of rolled beams and girders of standard sizes and shapes have been calculated for all usual dimensions by Hatfield,* and are given in Tables XCIV., XCV. and XCVI. The first of these tables contains the dimensions of cross section adopted by various makers, and the values of $I = \frac{1}{12}(bd^3 - b_1d_1^3)$, when b and b_1 are the breadth of flange and of web, and d and d_1 are their depths in inches. The second table gives the distances apart, centre to centre, adopted for dwellings and buildings in which the floor-loads are not exceptionally great, calculated by the formula.

$$c = \frac{255.009 I}{L^3} - \frac{w}{420} \dots \dots \dots (151)$$

in which c is the distance between centre lines of beams in inches; I is the moment of inertia in inch-pounds; L is the length of the beam in feet; w is the weight per yard in lbs.

The last of the three tables is calculated similarly for the use of beams and girders, of I-form, in heavily loaded floors, as in large stores and warehouses. These values of c were calculated by the formula

$$c = \frac{148.8 I}{L^3} - \frac{w}{960} \dots \dots \dots (152)$$

In these formulas, it is assumed that the value of the deflection is to be taken as

$$D = \frac{WL^3}{62000 bd^3}$$

for rectangular beams, a value obtained by experiment. The floor-load is taken at 70 pounds in dwellings and 250 pounds in warehouses; and a weight of 70 pounds per superficial foot for weight of arches and concrete between girders. The allowable deflection is assumed at 0.03 inch per lineal foot of beam for the first case and 0.045 for the second. All heavily loaded floors should be carefully recalculated.

* Transverse Strains; R. G. Hatfield. New York: J. Wiley and Sons, 1877.

British measures are used by all makers, and as the dimensions are all in that system, the tables are adapted to those measures.

TABLE XCIV.

ELEMENTS OF ROLLED-IRON BEAMS.

NAME.	$d =$ DEPTH.	WEIGHT PER YARD.	$b =$ BREADTH.	AVERAGE THICKNESS OF FLANGE.	THICKNESS OF WEB.	b_1	d_1	$I = \frac{bd^3}{12} - b_1d_1^3$
	In.	Lbs.	In.		In.	In.	In.	
Phoenix ...	4	18	2.	.268	.21	1.790	3.464	4.467
Paterson...	4	18	2.25	.281	.156	2.094	3.438	4.909
Phoenix ...	4	30	2.75	.400	.25	2.500	3.200	7.840
Trenton...	4	30	2.75	.400	.25	2.500	3.200	7.840
Buffalo....	4	30	2.75	.400	.25	2.500	3.200	7.840
Paterson...	4	30	2.75	.400	.25	2.500	3.200	7.840
Trenton...	4	37	3.	.456	.312	2.688	3.088	9.404
Paterson...	4	37	3.	.456	.312	2.688	3.088	9.404
Phoenix ...	5	30	2.75	.350	.25	2.500	4.300	12.082
Trenton...	5	30	2.75	.350	.25	2.500	4.300	12.082
Buffalo....	5	30	2.75	.350	.25	2.500	4.300	12.082
Paterson...	5	30	2.75	.350	.25	2.500	4.300	12.082
Phoenix ...	5	36	3.	.389	.3	2.700	4.222	14.317
Trenton...	5	40	3.	.454	.312	2.688	4.092	15.902
Paterson...	5	40	3.	.454	.312	2.688	4.092	15.902
Phoenix ...	6	40	2.75	.500	.25	2.500	5.000	23.458
Trenton...	6	40	3.	.454	.25	2.750	5.091	23.761
Buffalo....	6	40	3.	.454	.25	2.750	5.091	23.761
Paterson...	6	40	3.	.454	.25	2.750	5.091	23.761
Buffalo....	6	50	3.25	.532	.312	2.938	4.935	29.074
Trenton...	6	50	3.5	.500	.3	3.200	5.000	29.667
Paterson...	6	50	3.5	.500	.3	3.200	5.000	29.667
Phoenix ...	7	55	3.5	.484	.35	3.150	6.032	42.430
Trenton...	7	60	3.5	.540	.375	3.125	5.920	46.012
Buffalo....	7	60	3.5	.540	.375	3.125	5.920	46.012
Paterson...	7	60	3.5	.540	.275	3.125	5.920	46.012
Buffalo....	8	65	3.5	.560	.375	3.125	6.880	64.526
Phoenix ...	8	65	4.	.507	.35	3.650	6.886	66.963
Trenton...	8	65	4.	.554	.3	3.700	6.892	69.729
Paterson...	8	65	4.	.554	.3	3.700	6.892	69.729
Buffalo....	9	70	3.5	.500	.437	3.063	8.000	81.937
Trenton...	8	80	4.5	.606	.375	4.125	6.788	84.485
Paterson...	8	80	4.5	.610	.37	4.130	6.780	84.735

TABLE XCIV.—(Continued.)

ELEMENTS OF ROLLED-IRON BEAMS.

NAME.	$d =$ DEPTH.	WEIGHT PER YARD.	$b =$ BREADTH.	AVERAGE THICKNESS OF FLANGE.	THICKNESS OF WEB.	$b,$	$d,$	$I = \frac{bd^3}{12} - b'd'^3$
	In.	Lbs.	In.		In.	In.	In.	
Phoenix...	9	70	3.5	.660	.31	3.190	7.680	92.207
Trenton...	9	70	3.5	.672	.3	3.200	7.656	92.958
Paterson...	9	70	3.5	.672	.3	3.200	7.656	92.958
Phoenix...	9	84	4.	.667	.4	3.600	7.667	107.793
Buffalo...	9	90	4.	.643	.5	3.500	7.714	109.117
Paterson...	9	85	4.	.697	.384	3.616	7.605	110.461
Trenton...	9	85	4.	.701	.38	3.620	7.597	110.732
Buffalo...	10 $\frac{1}{2}$	90	4.437	.551	.437	4.000	9.397	151.436
Paterson...	9	125	4.5	.928	.58	3.920	7.143	154.320
Trenton...	9	125	4.5	.937	.57	3.930	7.125	154.917
Buffalo...	10 $\frac{1}{2}$	105	4.5	.656	.5	4.000	9.187	175.645
Phoenix...	10 $\frac{1}{2}$	135	4.5	.724	.44	4.060	9.052	183.164
Phoenix...	9	150	5.375	1.005	.6	4.775	6.990	190.630
Trenton...	10 $\frac{1}{2}$	105	4.5	.795	.375	4.125	8.909	191.040
Paterson...	10 $\frac{1}{2}$	105	4.5	.795	.375	4.125	8.909	191.040
Trenton...	10 $\frac{1}{2}$	135	5.	.945	.47	4.530	8.609	241.478
Paterson...	10 $\frac{1}{2}$	135	5.	.945	.47	4.530	8.609	241.478
Phoenix...	12	125	4.75	.777	.49	4.260	10.446	279.351
Buffalo...	12 $\frac{1}{4}$	125	4.5	.797	.5	4.000	10.656	286.019
Paterson...	12 $\frac{1}{4}$	125	4.79	.768	.48	4.310	10.714	292.050
Trenton...	12	125	4.8	.778	.47	4.330	10.693	294.136
Phoenix...	12	170	5.5	1.010	.59	4.910	9.980	385.284
Paterson...	12 $\frac{1}{4}$	170	5.5	.980	.6	4.900	10.280	398.936
Trenton...	12 $\frac{1}{8}$	170	5.5	.981	.6	4.900	10.351	402.538
Buffalo...	12 $\frac{1}{4}$	180	5.375	1.089	.625	4.750	10.072	418.945
Buffalo...	15	150	4.875	.761	.562	4.313	13.477	491.307
Paterson...	15 $\frac{3}{8}$	150	5.	.731	.56	4.440	13.725	502.883
Phoenix...	15	150	4.75	.882	.5	4.250	13.235	514.870
Trenton...	15 $\frac{3}{8}$	150	5.	.822	.5	4.500	13.542	528.223
Phoenix...	15	200	5.312	1.098	.65	4.662	12.803	678.684
Buffalo...	15	200	5.375	1.118	.625	4.750	12.763	688.775
Paterson...	15 $\frac{1}{8}$	200	5.5	1.048	.65	4.850	13.028	692.166
Trenton...	15 $\frac{1}{8}$	200	5.75	1.060	.6	5.150	13.004	714.205

TABLE XCV.

ROLLED-IRON BEAMS IN DWELLINGS, OFFICE BUILDINGS, AND HALLS OF ASSEMBLY.

Distances between Girders (*in feet*).

NAME.	DEPTH.	WEIGHT PER YARD.	LENGTH (<i>in feet</i>) BETWEEN BEARINGS.																			
			6	7	8	9	10	11	12	13	14	15	16	17	18	19	20	21	22			
Phoenix.	4	18	5.23	3.28	2.18	1.52																
Paterson	4	18	5.75	3.61	2.40	1.67	1.21															
Phoenix.	4	30	5.76	3.83	2.67	1.93	1.43														
Trenton.	4	30	5.76	3.83	2.67	1.93	1.43														
Buffalo.	4	30	5.76	3.83	2.67	1.93	1.43														
Paterson	4	30	5.76	3.83	2.67	1.93	1.43														
Trenton.	4	37	6.91	4.60	3.20	2.31	1.71	1.30													
Paterson	4	37	6.91	4.60	3.20	2.31	1.71	1.30													
Phoenix.	5	30	5.95	4.16	3.01	2.24	1.71	1.33												
Trenton.	5	30	5.95	4.16	3.01	2.24	1.71	1.33												
Buffalo..	5	30	5.95	4.16	3.01	2.24	1.71	1.33												
Paterson	5	30	5.95	4.16	3.01	2.24	1.71	1.33												
Phoenix.	5	36	7.05	4.02	3.57	2.66	2.03	1.58	1.24											
Trenton.	5	40	7.83	5.47	3.96	2.95	2.25	1.75	1.38											
Paterson	5	40	7.83	5.47	3.96	2.95	2.25	1.75	1.38											
Phoenix.	6	40	8.11	5.89	4.40	3.37	2.63	2.09	1.68	1.37									
Trenton.	6	40	8.22	5.97	4.46	3.41	2.66	2.11	1.70	1.38									
Buffalo..	6	40	8.22	5.97	4.46	3.41	2.66	2.11	1.70	1.38									
Paterson	6	40	8.22	5.97	4.46	3.41	2.66	2.11	1.70	1.38									
Buffalo..	6	50	7.30	5.45	4.17	3.26	2.58	2.08	1.69	1.39								
Trenton.	6	50	7.45	5.57	4.26	3.33	2.64	2.12	1.73	1.42								
Paterson	6	50	7.45	5.57	4.26	3.33	2.64	2.12	1.73	1.42								
Phoenix.	7	55	8.00	6.13	4.79	3.81	3.08	2.51	2.07	1.72	1.45						
Trenton.	7	60	8.67	6.65	5.20	4.13	3.33	2.72	2.25	1.87	1.57						
Buffalo..	7	60	8.67	6.65	5.20	4.13	3.33	2.72	2.25	1.87	1.57						
Paterson	7	60	8.67	6.65	5.20	4.13	3.33	2.72	2.25	1.87	1.57						
Buffalo..	8	65	9.37	7.34	5.84	4.72	3.86	3.19	2.67	2.24	1.90	1.62				
Phoenix.	8	65	7.62	6.07	4.91	4.01	3.32	2.77	2.33	1.98	1.69				
Trenton.	8	65	7.94	6.33	5.11	4.19	3.46	2.89	2.44	2.07	1.77				
Paterson	8	65	7.94	6.33	5.11	4.19	3.46	2.89	2.44	2.07	1.77				
Buffalo..	9	70	9.35	7.45	6.03	4.94	4.09	3.42	2.88	2.45	2.09	1.80			
Trenton.	8	80	9.62	7.66	6.19	5.07	4.20	3.50	2.95	2.50	2.14	1.83			
Paterson	8	80	9.65	7.69	6.21	5.09	4.21	3.52	2.96	2.51	2.14	1.84			

TABLE XCV.—(Continued.)

ROLLED-IRON BEAMS IN DWELLINGS, OFFICE BUILDINGS, AND HALLS OF ASSEMBLY.

Distances between Girders (*in feet*).

NAME.	DEPTH.	WEIGHT PER YARD.	LENGTH (<i>in feet</i>) BETWEEN BEARINGS.																																				
			14	15	16	17	18	19	20	21	22	23	24	25	26	27	28	29	30																				
Phoenix.	9	70	8.40	6.80	5.57	4.62	3.87	3.26	2.77	2.37	2.04	1.77																											
Trenton.	9	70	8.47	6.86	5.62	4.66	3.90	3.29	2.80	2.39	2.06	1.78																											
Paterson.	9	70	8.47	6.86	5.62	4.66	3.90	3.29	2.80	2.39	2.06	1.78																											
Phoenix.	9	84	9.82	7.95	6.51	5.40	4.51	3.81	3.24	2.77	2.36	2.06	1.79																										
Buffalo..	9	90	9.93	8.03	6.58	5.45	4.56	3.84	3.26	2.79	2.40	2.07	1.80																										
Paterson.	9	85	..	8.15	6.68	5.53	4.63	3.91	3.33	2.84	2.44	2.11	1.84																										
Trenton.	9	85	..	8.17	6.69	5.55	4.64	3.92	3.33	2.85	2.45	2.12	1.84																										
Buffalo..	10½	90	9.22	7.65	6.41	5.42	4.61	3.96	3.41	2.96	2.58	2.26	1.98	1.75																							
Paterson.	9	125	9.31	7.71	6.45	5.44	4.62	3.95	3.40	2.94	2.55	2.22	1.94	1.70																							
Trenton.	9	125	9.35	7.74	6.48	5.46	4.64	3.97	3.41	2.95	2.56	2.23	1.95	1.71																							
Buffalo..	10½	105	8.87	7.43	6.28	5.35	4.59	3.96	3.43	2.99	2.62	2.30	2.03	1.79																						
Phoenix.	10½	105	9.26	7.76	6.56	5.59	4.79	4.14	3.59	3.13	2.74	2.41	2.12	1.88																						
Phoenix.	9	150	9.54	7.98	6.73	5.72	4.89	4.21	3.64	3.16	2.75	2.41	2.11	1.86																						
Trenton.	10½	105	9.67	8.11	6.85	5.84	5.01	4.33	3.75	3.27	2.87	2.52	2.23	1.97	1.75																					
Paterson.	10½	105	9.67	8.11	6.85	5.84	5.01	4.33	3.75	3.27	2.87	2.52	2.23	1.97	1.75																					
Trenton.	10½	135	10.24	8.66	7.38	6.33	5.46	4.74	4.13	3.62	3.18	2.81	2.48	2.20	1.96																				
Paterson.	10½	135	10.24	8.66	7.38	6.33	5.46	4.74	4.13	3.62	3.18	2.81	2.48	2.20	1.96																				
Phoenix.	12	125	10.09	8.61	7.40	6.39	5.56	4.86	4.26	3.76	3.32	2.95	2.62	2.34																				
Buffalo..	12½	125	10.34	8.82	7.58	6.55	5.70	4.98	4.37	3.85	3.41	3.03	2.69	2.40																				
Paterson.	12½	125	10.56	9.01	7.75	6.70	5.82	5.09	4.47	3.94	3.49	3.10	2.76	2.46																				
Trenton.	12½	125	10.64	9.08	7.80	6.75	5.87	5.13	4.50	3.97	3.51	3.12	2.78	2.48																				
Phoenix.	12	170	10.21	8.82	7.67	6.70	5.88	5.19	4.59	4.07	3.62	3.23																				
Paterson.	12½	170	10.58	9.15	7.96	6.96	6.11	5.38	4.70	4.23	3.77	3.36																				
Trenton.	12½	170	10.68	9.24	8.03	7.02	6.17	5.44	4.81	4.27	3.80	3.40																				
Buffalo..	12½	180	9.61	8.35	7.30	6.41	5.65	5.00	4.44	3.95	3.53																				
Buffalo..	15	150	9.94	8.71	7.66	6.77	6.01	5.35	4.78	4.28																				
Paterson.	15	150	10.19	8.92	7.85	6.94	6.16	5.49	4.90	4.39																				
Phoenix.	15	150	10.44	9.14	8.05	7.11	6.32	5.63	5.03	4.51																				
Trenton.	15	150	10.72	9.39	8.27	7.31	6.49	5.78	5.17	4.63																				
Phoenix.	15	200	10.60	9.37	8.32	7.41	6.62	5.94																			
Buffalo..	15	200	10.77	9.52	8.45	7.53	6.73	6.03																			
Paterson.	15½	200	10.82	9.57	8.49	7.57	6.76	6.06																			
Trenton.	15½	200	11.18	9.89	8.78	7.82	6.99	6.27																			

TABLE XCVI.

ROLLED-IRON BEAMS IN FIRST-CLASS STORES.

Distances between Girders (*in feet*).

NAME.	DEPTH.	WEIGHT PER YARD.	LENGTH (<i>in feet</i>) BETWEEN BEARINGS.																
			6	7	8	9	10	11	12	13	14	15	16	17	18	19			
Phoenix.....	4	18	3.06	1.92	1.28														
Paterson.....	4	18	3.36	2.11	1.41														
Phoenix.....	4	30	5.37	3.37	2.25	1.57	1.14												
Trenton.....	4	30	5.37	3.37	2.25	1.57	1.14												
Buffalo.....	4	30	5.37	3.37	2.25	1.57	1.14												
Paterson.....	4	30	5.37	3.37	2.25	1.57	1.14												
Trenton.....	4	37	6.44	4.04	2.69	1.88	1.36												
Paterson.....	4	37	6.44	4.04	2.69	1.88	1.36												
Phoenix.....	5	30	8.29	5.21	3.48	2.43	1.77	1.32											
Trenton.....	5	30	8.29	5.21	3.48	2.43	1.77	1.32											
Buffalo.....	5	30	8.29	5.21	3.48	2.43	1.77	1.32											
Paterson.....	5	30	8.29	5.21	3.48	2.43	1.77	1.32											
Phoenix.....	5	36	...	6.17	4.12	2.88	2.09	1.56											
Trenton.....	5	40	...	6.86	4.58	3.20	2.32	1.74	1.33										
Paterson.....	5	40	...	6.86	4.58	3.20	2.32	1.74	1.33										
Phoenix.....	6	40	6.77	4.75	3.45	2.58	1.98	1.55									
Trenton.....	6	40	6.86	4.81	3.49	2.61	2.00	1.57									
Buffalo.....	6	40	6.86	4.81	3.49	2.61	2.00	1.57									
Paterson.....	6	40	6.86	4.81	3.49	2.61	2.00	1.57									
Buffalo.....	6	50	8.40	5.88	4.27	3.20	2.45	1.92	1.52								
Trenton.....	6	50	8.57	6.00	4.36	3.26	2.50	1.96	1.56								
Paterson.....	6	50	8.57	6.00	4.36	3.26	2.50	1.96	1.56								
Phoenix.....	7	65	8.60	6.26	4.69	3.60	2.82	2.24	1.81	1.48						
Trenton.....	7	60	9.33	6.78	5.08	3.90	3.05	2.43	1.97	1.62						
Buffalo.....	7	60	9.33	6.78	5.08	3.90	3.05	2.43	1.97	1.61						
Paterson.....	7	60	9.33	6.78	5.08	3.90	3.05	2.43	1.97	1.61						
Buffalo.....	8	65	9.53	7.15	5.49	4.30	3.43	2.78	2.28	1.80	1.58					
Phoenix.....	8	65	9.90	7.42	5.70	4.47	3.56	2.88	2.36	1.96	1.64					
Trenton.....	8	65	7.73	5.94	4.65	3.71	3.01	2.46	2.04	1.71						
Paterson.....	8	65	7.73	5.94	4.65	3.71	3.01	2.46	2.04	1.71						
Buffalo.....	9	70	9.09	6.98	5.48	4.37	3.54	2.90	2.41	2.02	1.70				
Trenton.....	8	80	9.36	7.19	5.64	4.50	3.64	2.99	2.48	2.07	1.75				
Paterson.....	8	80	9.39	7.21	5.66	4.51	3.65	2.99	2.48	2.08	1.75				

Buckled Plates are often used for flooring and for other cases of superficially distributed loads. They are usually square—a dished centre with plane flanges at the edges to take the bearing and to receive bolts.

Secured on all sides, they carry twice the load sustained if merely supported all around. Their stiffness varies as the square of the thickness and inversely as their radius of curvature. They are usually of iron, about 3 feet (0.91 metre) or 4 feet (1.22 metres) square, $\frac{1}{4}$ inch thick (0.62 centimetre) and buckled two inches. These plates will carry safely a half ton per square foot (0.09 metre). Steel plates are loaded twice as heavily.

Corrugated Plate is given a pitch of from 3 to 5 inches from crest to crest, and is largely used for roofing. Its load is taken* as

$$W = 44.6 \frac{tbd}{l} \dots \dots \dots (153)$$

where l , b , t and d are the length, breadth and thickness of plate and the total depth of the corrugations, all in inches. W = tons.

The strength of a rectangular plate being taken as unity when supported at two sides and loaded uniformly, the load that it will carry will vary as follows, according to method of support :

FORM OF PLATE.	SUPPORTED.	LOAD.	STRENGTH.
Square	On all sides	Distributed	2.
"	" " "	Central	6.
Circular	" " "	Distributed	3.14
"	" " "	Central	9.42
Square	Fixed (riveted) all around	Distributed	3.
"	" " " "	Central	9.
Circular	" " " "	Distributed	4.8
"	" " " "	Central	14.1

* Molesworth.

According to Grashof a circular plate will bear a pressure if bolted along the edge,

$$p = \frac{3}{2} \frac{Tt^2}{r^2} \dots \dots \dots (154)$$

when T is the tenacity, t the thickness, and r the radius, similar units being used throughout.

272. Shearing is produced by sets of opposed forces acting in the same or parallel planes, as where a punch is used or where metal is "sheared."

The shearing resistance of iron is usually taken as equal to its resistance to tension, and varies with form and dimensions from 45,000 to 60,000 pounds per square inch (3,164 to 4,218 kilogrammes per square centimetre). The shearing resistance of steel varies from that of good wrought iron to double that value or more, according to its composition. Steel is usually, however, less capable of resisting "unfair" strains than is iron, and a good value of this form of resistance may be taken as

$$\left. \begin{aligned} S &= 60,000 + 40,000 C \\ S_m &= 4,218 + 2,812 C \end{aligned} \right\} \dots \dots \dots (155)$$

where C is the percentage of carbon.

The shearing strength of cast iron varies irregularly from 15,000 to 40,000 pounds per square inch (1,055 to 2,812 kilogrammes per square centimetre) of sheared section, and is most safely taken at the lower figure. Its value is usually not far from that of the tensile resistance to which it may be taken as equal. The resistance of boiler plates to punching, of riveted wrought iron-work and of iron bridge pins to shearing has been found variable with ordinary materials between the limits, usually, of 50,000 and 55,000 pounds per square inch (3,515 to 3,866 kilogrammes), and may be taken in estimates and specifications at the lower amount. A very extensive set of experiments upon the strength of bolts and nuts, conducted by the Author, gave figures lower than the above by 20 per cent. or more.

In consequence of the liability, which is always to be apprehended, that the shearing will not take place in such a manner as to permit the piece sheared to offer its maximum resistance, it is usual to assume a loss of from one-fourth to one-fifth, and to take $S = \frac{3}{4}T$, or $S = \frac{4}{5}T$. Taking the latter proportion, the ordinary working value of S becomes, for iron 40,000 to 45,000 pounds, and

$$\left. \begin{aligned} S' &= 48,000 + 32,000 C \\ S'_m &= 3,374 + 2,250 C \end{aligned} \right\} \dots \dots (156)$$

for steel, which value may be used in all ordinary constructions built of known grades of good metal. For other cases not settled by experiment, the engineer assumes the maximum shearing resistance as nearly equal to the tenacity of the metal.

Coupling bolts, in shaft couplings, are exposed to this action. They may be proportioned either by making this stress, as above, a safe minimum, or by direct calculation from the size of shaft, as is done by Rankine, who makes their diameter,

$$d = \sqrt{\frac{d'^3}{3nr}} \dots \dots \dots (157)$$

in which d is the diameter of the bolt, d' that of the shaft, n the number of bolts, and r the radius of the circle passing through their centres.

273. Riveted work is subject to injury by the tearing out of the rivets through the sheet, when the shearing resistance of the latter is too low, by pulling off the heads when the stress is in line with the axis of the rivet, and by the shearing of the rivet when of too small area of section. The joint has maximum value when no more likely to yield in one of these ways than in another. *Loosely* fitted rivets and pins have from $\frac{2}{3}$ to $\frac{7}{8}$ the shearing resistance of tightly fitted rivets; which latter have practically the full strength due the section sheared. The diameter of the rivet should be about twice

the thickness of the plate, but the size is often determined by practical considerations. A common range of sizes is the following, although no fixed rule is settled upon :

TABLE XCVII.

		SIZE OF RIVETS.								
Thickness of plate, inches		$\frac{3}{16}$	$\frac{1}{4}$	$\frac{5}{16}$	$\frac{3}{8}$	$\frac{7}{16}$	$\frac{1}{2}$	$\frac{5}{8}$	$\frac{3}{4}$	
" " "	centimetres	0.48	0.64	0.80	0.96	1.12	1.27	1.60	1.92	
Diameter of rivet, inches		$\frac{1}{2}$	$\frac{5}{8}$	$\frac{3}{4}$	$\frac{7}{8}$	$\frac{7}{8}$	1	$1\frac{1}{4}$	$1\frac{1}{2}$	
" " "	centimetres	1.27	1.60	1.92	2.08	2.08	2.54	3.17	3.81	

The distance between centres, the *pitch* of the rivets, should be, in iron,

$$p = 0.7854 \frac{d^2}{t} + d \dots \dots \dots (158)$$

where d is the diameter of the rivet, t the thickness of the sheet.

In steel, the same rule applies when riveted with rivets of the same quality with the sheet ; otherwise, we must have, when S is the shearing resistance per unit of area of the rivet-section, and S' that of the sheet,

$$S \frac{\pi d^2}{4} = S'(p - d)t,$$

and

$$p = \frac{S}{S'} \frac{\pi d^2}{4t} + d$$

$$= 0.7854 \frac{Sd^2}{S't} + d \dots \dots \dots (159)$$

When the sheet is of rather hard steel and the rivet of iron, the sheet is liable to cut the rivet, and the value of S should therefore be taken low.

The length of the rivet is usually about

$$l = 2t + 2\frac{1}{4}d \dots \dots \dots (160)$$

exceeding the length of the rivet hole by $2\frac{1}{2}$ times its diameter.

For double riveting and joints held by several rows, n , of rivets,

$$p = 0.7854 \frac{Snd^2}{S't} + d. \quad \dots \quad (161)$$

The lap of the joint should be sufficient to allow ample margin for chipping or planing and caulking, as well as safe against the tearing out of the rivet.

Fairbairn gives the following table as exhibiting the proportions by him determined experimentally:

TABLE XCVIII.
PROPORTION OF RIVETS.

THICKNESS OF PLATE.		DIAMETER OF RIVETS.		LENGTH OF RIVETS		LAP OF SINGLE RIVETING.		PITCH OF RIVETS.	
In.	Cm.	In.	Cm.	In.	Cm.	In.	Cm.	In.	Cm.
$\frac{3}{16}$	0.48	$\frac{3}{8}$	0.95	$\frac{7}{8}$	2.22	$1\frac{1}{4}$	3.18	$1\frac{1}{4}$	3.18
$\frac{1}{4}$	0.64	$\frac{1}{2}$	1.27	$1\frac{1}{8}$	2.86	$1\frac{1}{2}$	3.81	$1\frac{1}{2}$	3.81
$\frac{1}{2}$	0.79	$\frac{3}{4}$	1.59	$1\frac{3}{8}$	3.49	$1\frac{3}{4}$	4.76	$1\frac{3}{4}$	4.13
$\frac{3}{4}$	0.95	1	1.91	$1\frac{1}{2}$	4.13	2	5.08	$1\frac{3}{4}$	4.45
1	1.27	$1\frac{1}{4}$	2.54	$2\frac{1}{4}$	5.72	$2\frac{1}{2}$	5.72	2	5.08
$1\frac{1}{4}$	1.59	$1\frac{1}{2}$	3.17	$2\frac{3}{4}$	6.99	$2\frac{3}{4}$	6.99	$2\frac{1}{2}$	6.35
$1\frac{3}{4}$	1.91	$1\frac{3}{4}$	3.81	$3\frac{1}{4}$	8.26	$3\frac{1}{4}$	8.26	3	7.62

Engineer-in-Chief W. H. Shock, U. S. N.,* finds bolts or rivets in double shear to exceed in resistance those in single shear by the following amount:

- $\frac{1}{2}$ inch (1.27 cm.) diameter..... 86.2 per cent.
- $\frac{3}{8}$ inch (1.59 cm.) diameter..... 97.0 per cent.
- $\frac{3}{4}$ inch (1.9 cm.) diameter..... 101.1 per cent.
- $\frac{7}{8}$ inch (2.22 cm.) diameter..... 82.6 per cent.
- 1 inch (2.54 cm.) diameter..... 85.0 per cent.

These results are too irregular to indicate any law, and it can only be said that the gain by double shear is usually 80

* Treatise on Steam Boilers, W. H. Shock, N. Y.: D. Van Nostrand, 1881.

or 90 per cent. The average of single shear is nearly 40,000 and in double shear, 35,000 pounds per square inch (2,812 and 2,460 kilogrammes per square centimetre). English iron, in boiler plate, when punched, gave* an average of about 55,000 pounds per square inch (3,867 kilogrammes per square centimetre).

Pins and Bolts in shear should be calculated with a large factor of safety when in thin metal, in order that they may not cut the eye.

Eyebars.—A common rule for “eyebars” at the head where receiving the pin, makes them thus :

Diameter of pin	1
Diameter of head, minimum	2 $\frac{2}{3}$
Radius of curve of neck	2
Width of body of bar	1 $\frac{1}{2}$

The end of the head should be increased in depth above the eye until equal to $1\frac{1}{3}$ the diameter of the pin, and it is a good practice to give the whole head an elliptical form, with a major axis 3, and minor axis $1\frac{2}{3}$ times the diameter of pin, in order to avoid distortion under stress which leads to tearing rather than a square break across the pin. A board of U. S. naval officers recommended the following proportions :

Breadth of bar	1
Diameter of pin	0.917
Thickness each side	0.555
Thickness at crown	0.722
Depth of eye	equal to thickness of bar.

274. **The Shearing of Nuts** has been studied by the Author, in an exhaustive series of experiments, with results as below.† It was, however, necessary to turn off the face of the nuts, and to reduce their thickness considerably, in order that they should strip instead of breaking the *steel* bolts on which they were tested. An ill-fitted nut will often strip the thread, and thus fail by shearing the metal; a well-fitted nut will always break its bolt if made of the usual

* *Proc. Inst. Mech. Eng'rs.*

† *R. R. Gazette, Iron Age, etc., 1877.*

proportions. When turned, as here, they broke through the side, or stripped, with nearly equal frequency. The $\frac{1}{2}$ -inch (1.27 centimetres) nuts were 0.44 inch (1.12 centimetres) thick; the $\frac{5}{8}$ -inch (1.59 centimetres) were 0.6 (1.52 centimetres); the $\frac{3}{4}$ -inch (1.91 centimetres) and the $\frac{7}{8}$ -inch (2.22 centimetres) nuts were both 0.72 inch (1.83 centimetres) thick.

Nuts broke and stripped without regularity at all loads, and the average figures given may be safely assumed to be fair figures for the basis of calculation of strength on the assumption that the nut will rupture by shearing.

TABLE XCIX.
STRIPPING OR BREAKING RESISTANCE.
Pounds per Square Inch of Shearing Area.

MATERIAL.		$\frac{1}{2}$ INCH.		$\frac{5}{8}$ INCH.		$\frac{3}{4}$ INCH.		$\frac{7}{8}$ INCH.	
		Cold Punched. Lbs.	Hot Pressed. Lbs.	Cold Punched. Lbs.	Hot Pressed. Lbs.	Cold Punched. Lbs.	Hot Pressed. Lbs.	Cold Punched. Lbs.	Hot Pressed. Lbs.
Stock Nuts.	Max.	43,908	39,387	46,159	36,937	41,238	36,776	40,939	40,411
	Min.	34,234	29,322	36,988	25,544	37,319	29,345	31,063	30,149
	Av'ge.	39,351	34,394	41,489	32,600	39,101	32,732	38,259	32,834
A Iron.	Max.	44,541	35,711	45,680	36,605	43,460	35,115	39,507	33,398
	Min.	26,459	25,977	38,700	30,006	38,011	29,450	33,402	27,525
	Av'ge.	37,739	31,299	41,063	33,691	40,956	33,561	36,847	31,304
B Iron.	Max.	48,307	39,236	45,699	39,722	43,905	35,278	40,048	33,355
	Min.	38,001	29,714	39,722	30,653	34,603	32,282	35,495	30,696
	Av'ge.	42,096	36,356	43,139	34,467	39,526	34,491	37,788	31,353

It would probably be safe to take the shearing resistance of cold-punched nuts at 40,000, and of hot pressed nuts at 35,000, pounds per square inch (2,812 and 2,460 kilogrammes on the square centimetre) in ordinary work.

The resistance that may usually be calculated upon, assuming iron used having a shearing resistance and tenacity of 50,000 pounds per square inch, is taken as for

	Lbs. per sq. in.	Kgs. per sq. cm.
Double-riveted joint	35,000	2,460
Single-riveted joint	28,000	1,468
Single-riveted joint—breaking joint	34,000	2,390

Resilience in Shearing is often essential in construction. The Author has found, in some cases, that the resilience of iron armor plate has been nearly

$$\frac{Wv^2}{2g} = 10,000dt^2 \dots \dots \dots (162)$$

and the thickness penetrated

$$t = \sqrt{\frac{Wv^2}{600,000d}} \dots \dots \dots (163)$$

when W is the weight of shot, v the striking velocity in feet per second, and d the diameter of the shot in inches. In metric measures, kilogrammes and metres,

$$\frac{Wv^2}{2g} = 15dt^2, \text{ nearly } \dots \dots \dots (164)$$

$$t = \sqrt{\frac{Wv^2}{1,000d}}, \text{ nearly } \dots \dots \dots (165)$$

The potential energy of gunpowder should be 250,000 or 300,000 foot-pounds per pound (80,000 or 90,000 kilogrammetres per kilogramme). The velocities of shot range up to over 2,000 feet (over 600 metres) per second.

275. Punching.—The strength of iron and steel is often greatly affected by punching, and it is usually specified, for riveted work, that no steel plates shall be punched to size, but that all rivet-holes shall either be punched small and the holes reamed out to size, or, better, that they shall be drilled and their edges slightly chamfered or rounded. With soft ingot iron, such as only should be used for steam boilers, this injury probably does not occur. Hard iron is sometimes injured by punching, but soft iron may even be strengthened by the process, sometimes as much as 10 per cent.*

276. The Torsional Strength and elasticity of iron and steel have been less thoroughly investigated than either of the other forms of resistance.

* *Railroad Gazette*, Nov. 13, 1876.

The moment of the applied force, as measured by the product of the magnitude of that force into the length of its lever-arm, at each instant equilibrates the resistance, and the formula for elastic resistance becomes :

$$Fl = M = \frac{2\pi s}{r_1} \int_{r_0}^{r_1} r^3 dr.$$

For solid cylinders,

$$Fl = M = 1.5708sr_1^3 = 0.2sd^3. \quad . \quad . \quad (166)$$

For hollow cylinders,

$$Fl = M = 1.5708s \left(\frac{r_1^4 - r_0^4}{r_1} \right) = 0.2s \cdot \frac{d_1^4 - d_0^4}{d_1}. \quad (167)$$

where F is the applied force, l its lever-arm, M its moment, s the resistance of the material on the unit of area, or the maximum stress, r_0 and r_1 are the radii of the shaft, internal and external, and d_0 and d_1 are the diameters.

The *angle of torsion* is proportional to the length of the part twisted and to the torsional moment. The formula giving its value is

$$\alpha = \frac{2Mx}{C\pi r_1^4} = \frac{32M}{\pi d_1^4} \cdot \frac{x}{C} = 10.2 \frac{Flx}{Cd_1^4}. \quad . \quad . \quad (168)$$

x being the length of the part twisted.

$$Fl = M = \alpha C \frac{\pi d_1^4}{32x} = 0.098C \frac{d_1^4 \alpha}{x}. \quad . \quad . \quad (169)$$

in which formulas C is the coefficient of elasticity of torsion, which may be taken as follows for British and metric measures :

	C .	C_m .	S .	S_m .
	Inches ; pounds.	Kgs. ; mm.	Lbs. on sq. in.	Kgs. on sq. cm.
Cast iron.....	3,000,000	2,100	20,000	1,400
Wrought iron and steel.....	10,000,000	7,000	{ 50,000 to 150,000	{ 3,500 to 10,500
Steel, tempered....	12,000,000	8,400	150,000	10,500

Helical Springs.—The torsion of a coiled wire in the form of a helical or a spiral spring, gives rise to resistance, which may be thus estimated: Assuming the weight, W , to be applied in the axial line, and thus to have a lever-arm, R :

$$WR = M = \frac{\pi \alpha}{32} \cdot \frac{Cd^4}{x} = \frac{\pi}{32} \cdot \frac{y}{R} \cdot \frac{Cd^4}{2\pi Rn} = \frac{Cy}{64} \cdot \frac{d^4}{nR^3} \quad (170)$$

$$y = \frac{64WnR^3}{Cd^4} \quad \dots \quad (171)$$

where α is the angle of torsion of the wire, as before, d the diameter, n the number of coils, and y is the deflection. The value of C is as above, and is sufficiently accurate to determine, generally, the size of the spring; but the spring itself should always be tested and standardized when intended for exact measurement, as in dynamometers and indicators.

Rankine gives for safe loading:

For round steel (d is in 16ths of an inch),

$$d = \sqrt[3]{\frac{wd_1}{3}} \quad \dots \quad (172)$$

For square steel,

$$d = \sqrt[3]{\frac{wd_1}{4.3}} \quad \dots \quad (173)$$

figures which are found to accord well with results of tests made under the direction of the Author.

In the report of a committee of the Institution of Engineers and Shipbuilders in Scotland, the following is proposed:

$$D = \frac{nwd_1^3}{ad} \quad \dots \quad (174)$$

in which D is the deflection in inches, n the number of coils, d_1 the diameter of the coil, w the load in pounds, d the diameter of the wire, and a a constant, 22 for round and 30 for square steel.

277. **The Strength of a Metal Shaft** depends not only on the magnitude of the ultimate resistance of the material, but upon the method of its action. With brittle materials, fracture must occur when the limit of resistance of the outer layers is reached; with ductile metals, capable of flow, fracture may not take place until all, or nearly all, parts of the cross section have been highly strained, the outer portions yielding by flow until the inner parts have been strained to their maximum.

For the first case, we have for the area of each elementary ring, $2\pi r dr$, for the stress upon it $s = \frac{s_1 r}{r_1}$, and for its lever-arm, r .

Then

$$Fl = M = \frac{2\pi s_1}{r} \int_{r_0}^{r_1} r^3 dr = \frac{1}{2} \frac{\pi s_1}{r_1} (r_1^4 - r_0^4) = \frac{1}{16} \pi \frac{s}{d_1} (d_1^4 - d_0^4). \quad (175)$$

for hollow shafts, and when $r_0 = 0$, $d_0 = 0$, as for solid shafts,

$$Fl = M = 1.5708 s_1 r_1^3 = 0.196 s_1 d^3 \quad \dots \quad (176)$$

To obtain the diameter, we have

For solid shafts,

$$d_1 = \sqrt[3]{\frac{5.1 Fl}{s_1}} \quad \dots \quad (177)$$

For hollow shafts,

$$d_1 = \sqrt[3]{\frac{5.1 Fl}{s_1 \left(1 - \frac{d_0^4}{d_1^4}\right)}} \quad \dots \quad (178)$$

In these formulas, the ultimate resistance may be taken as already given for tension, and the factor of safety should usually be large.

When the material is capable of flow to such an extent that the whole section resists with maximum effect, we have the elementary area as before— $2\pi r dr$, its lever-arm r , and the value of s becomes constant and equal to s_1 .

Then

$$Fl = 2\pi s_1 \int_{r_0}^{r_1} r^2 dr = \frac{2}{3} \pi s_1 (r_1^3 - r_0^3) = 0.26s_1 (d_1^3 - d_0^3). \quad (179)$$

and when $r_0 = 0$,

$$Fl = 0.26s_1 d_1^3 = 2.15s_1 r_1^3. \quad \dots \quad (180)$$

In such cases, therefore, the strength of the shaft is increased one-third by the ductility of the metal. It is uncertain to what extent this action occurs, and it is still more uncertain to what extent the action here occurring is a true shearing action. The last set of formulas, above deduced, are rarely used by the engineer.

When the section is square the resistance is increased about 40 per cent. above that of a circular section having a diameter equal to the side of the square.

The real condition of the metal under stress is undoubtedly always intermediate between the two cases above taken, the metal near the centre resisting as a solid shaft strained within the elastic limit at its outer bounding surface, while the external portion acts as a hollow shaft strained throughout beyond that limit. Assuming the latter to be strained to the maximum throughout, and taking r_1 r_2 as the radii of the two parts, the total resistance would be

$$\begin{aligned} Fl = M &= \frac{\pi}{2} s_1 r_1^3 + \frac{2\pi}{3} s_1 (r_2^3 - r_1^3) \\ &= 0.52s_1 (4r_2^3 - r_1^3). \quad \dots \quad (181) \end{aligned}$$

If α_e and α_r are the angles of torsion at the elastic limit of the piece and at the beginning of rupture or of flow,

$$r_1 = \frac{\alpha_e}{\alpha_r} r_2,$$

and

$$Fl = M = \frac{1}{6} \pi s r_2^3 \left(4 - \frac{\alpha_e^3}{\alpha_r^3} \right).$$

If $\alpha_e = \alpha_r$, $M = \frac{1}{2}\pi sr^3$, as already shown for brittle substances. When $\alpha_e = 0$, as in absolutely inelastic materials, did such exist, or when $\alpha_r = \infty$, as with perfectly ductile substances, $M = \frac{2}{3}\pi sr^3$, as already deduced for substances capable of unlimited flow.

When the torsional moment is given, the diameter of a shaft in inches is given by Molesworth as

$$d = \sqrt[3]{\frac{Pl}{K}} \dots \dots \dots (182)$$

in which

- d = diameter in inches.
- l = lever-arm in inches.
- P = twisting effort in pounds.

VALUES OF K .

Wrought iron.....	1,700	Cast iron	1,500
Cast steel	3,200	Gun bronze.....	460
Copper.....	380	Brass	425
Tin	220	Lead	170

Common formulas used in shop practice are :
 For steam-engine shafts and first-motion shafts,

$$d = 4.5 \sqrt[3]{\frac{HP}{R}} \dots \dots \dots (183)$$

For shafts for transmission,

$$d = 4 \sqrt[3]{\frac{HP}{R}} \dots \dots \dots (184)$$

where d is the diameter as above, HP the transmitted horse-power, and R the number of revolutions per minute.

The following may be taken as safer average working formulas for shafting of ordinary iron, often adopted in ordinary work :

For head shafts well supported against springing:

$$P = \frac{d^3 R}{125} = \frac{d_m^3 R}{2000}; \quad d = \sqrt[3]{\frac{125 HP}{R}}; \quad d_m = \sqrt[3]{\frac{2000 HP}{R}}. \quad (185)$$

For line shafting; hangers 8 feet ($2\frac{1}{2}$ metres) apart:

$$P = \frac{d^3 R}{90} = \frac{d_m^3 R}{1450}; \quad d = \sqrt[3]{\frac{90 HP}{R}}; \quad d_m = \sqrt[3]{\frac{1450 HP}{R}}. \quad (186)$$

For transmission simply; no pulleys:

$$P = \frac{d^3 R}{62.5} = \frac{d_m^3 R}{1000}; \quad d = \sqrt[3]{\frac{62.5 HP}{R}}; \quad d_m = \sqrt[3]{\frac{1000 HP}{R}}. \quad (187)$$

For cold-rolled iron, these formulas become:

$$HP = \frac{d^3 R}{75} = \frac{d_m^3 R}{1200}; \quad d = \sqrt[3]{\frac{75 HP}{R}}; \quad d_m = \sqrt[3]{\frac{1200 HP}{R}}. \quad (188)$$

$$HP = \frac{d^3 R}{55} = \frac{d_m^3 R}{880}; \quad d = \sqrt[3]{\frac{55 HP}{R}}; \quad d_m = \sqrt[3]{\frac{880 HP}{R}}. \quad (189)$$

$$HP = \frac{d^3 R}{35} = \frac{d_m^3 R}{550}; \quad d = \sqrt[3]{\frac{35 HP}{R}}; \quad d_m = \sqrt[3]{\frac{550 HP}{R}}. \quad (190)$$

Here HP = horse-power transmitted; d = diameter of shaft in inches; d_m in centimetres; R = revolutions per minute.

Francis gives the following as permissible distances between bearings for shaftings carrying no side strain:

TABLE C.
SPANS FOR SHAFTING.

DIAMETER OF SHAFT.		DISTANCE BETWEEN BEARINGS.			
		Wrought Iron.		Steel.	
Inches.	Centimetres.	Feet.	Metres.	Feet.	Metres.
2	5.08	15.5	4.7	15.9	4.8
3	7.62	17.7	5.4	18.2	5.5
4	10.16	19.5	6.0	20.0	6.1
5	12.70	20.9	6.4	21.6	6.5
6	15.24	22.3	6.8	22.9	6.9
7	17.78	23.5	7.1	24.1	7.3
8	20.32	24.6	7.5	25.2	7.7
9	22.86	25.5	7.8	26.2	8.0

These distances may usually be safely obtained from the formulas:

$$D = 12 \sqrt[3]{d}; D_m = 3 \sqrt[3]{d_m} \dots (191)$$

where D, D_m are distances in British and metric measures, between bearings, d, d_m are the diameters of the shafts.

In designing steam-engine shafts and other similar pieces the diameter is sometimes expressed in other terms. Thus the Author has used, in designing, the formula, for a single shaft, for long-stroked engines,

$$d = \sqrt[3]{\frac{d'^2 p L}{250}} \dots (192)$$

in which d is the minimum diameter of the shaft in inches, d' that of the steam cylinder in inches, and L the stroke of piston in feet, and p the steam pressure in pounds per square inch. In metric measures, kilogrammes, and centimetres,

$$d_m = 11 \sqrt[3]{d'^2 p l}, \text{ nearly } \dots (193)$$

For screw engines the diameter is usually from one-eighth to one-sixth greater.

Shafts are generally made of wrought iron; cold-rolled shafting is common; steel shafts and shafting are coming into use, both of common and Whitworth steel.

Cast iron is rarely used to resist this kind of stress.

278. The Metals, and their Strain Diagrams.*—Fig. 98 exhibits a series of curves which illustrate well the general characteristics and the peculiarities of representative specimens of the principal varieties of useful metals. In some cases two specimens have been chosen for illustration, of which one presents the average quality, while the other is the best and most characteristic of its class.

Wrought iron, as usually made, has a somewhat fibrous structure, which is produced by particles of cinder, originally left in the mass by the imperfect work of the puddler while forming the ball of sponge in his furnace, and which, not having been removed by the squeezers or by hammering the puddle ball, are, by the subsequent process of rolling, drawn out into long lines of non-cohering matter, and produce an effect upon the mass of metal which makes its behavior under stress somewhat similar to that of the stronger and more thready kinds of wood. In the low steels, also, in which, in consequence of the deficiency of manganese accompanying, almost of necessity, their low proportion of carbon, this fibrous structure is produced by cells and "bubble holes" in the ingot refusing to weld up in working, and drawing out into long microscopic, or less than microscopic, capillary openings.

In consequence of this structure we find a depression interrupting the regularity of their curves, immediately after passing the limit of elasticity, precisely as the same indication of the lack of homogeneousness of structure was seen in the diagrams produced by locust and hickory.†

The presence of internal strain constitutes an essential peculiarity of the metals which distinguishes them from or-

* From a paper by the Author; *Trans. Am. Soc. C. E.*, 1874. † Part 7

ganic materials. The latter are built up by the action of molecular forces, and their particles assume naturally, and probably invariably, positions of equilibrium as to strain. The same is true of naturally formed inorganic substances. The metals, however, are given form by external and artificially produced forces. Their molecules are compelled to assume certain relative positions, and those positions may be those of equilibrium, or they may be such as to strain the cohesive forces to the very limit of their reach. It even frequently happens, in large masses, that these internal strains actually result in rupture of portions of the material at various points, while in other places the particles are either strongly compressed, or are on the verge of complete separation by tension. This peculiar condition must evidently be of serious importance where the metal is brittle, as is illustrated by the behavior of cast iron, and particularly in ordnance. Even in ductile metals it must evidently produce a reduction in the power of the material to resist external forces.

Since straining the piece to the limit of elasticity brings all particles subject to this internal strain into a similar condition, as to strain, with adjacent particles, it is evident that indications of the existence of internal strain, and, through such indications, a knowledge of the value of the specimen, as affected by this condition, must be sought in the diagram before the sharp change of direction which usually marks the position of the limit of elasticity is reached. As already seen, the initial portion of the diagram, when the material is free from internal strain, is a straight line up to the limit of elasticity. A careful observation of the tests of materials of various qualities, while under test, has shown that, as would, from considerations to be stated more fully hereafter in treating of the theory of rupture, be expected, this line, with strained materials, becomes convex toward the base line, and the form of the curve, as will be shown, is parabolic. The initial portion of the diagram, therefore, determines readily whether the material tested has been subjected to internal strain, or whether it is homogeneous as to strain.

Missing Page

This is exhibited by the *direction* of this part of the line as well as by its form. The existence of internal strain causes a loss of stiffness, which is shown by the deviation of this part of the line from the vertical to a degree which becomes observable by comparing its inclination with that of the line of elastic resistance obtained by relaxing the distorting force—*i.e.*, the difference in inclination of the initial line of the diagram and the lines of elastic resistance, e, e, e , indicates the amount of existing internal strains. (See p. 346.)

279. Strain Diagram of Forged Iron.—In Fig. 98 the curves numbered 6, 1, 22 and 100, are the diagrams produced by three characteristic grades of wrought iron. The first is a quality of English iron, well known in our market as a superior metal. The second is one of the finest known brands of American iron, and the third is also of American make, but it does not usually come into the market in competition with well-known irons, in consequence of the high price which is consequent upon the necessary employment of an unusual amount of labor in securing its extraordinarily high character.

No. 6 at first yields rapidly under moderate force, only about 50 foot-pounds of torsional moment being required to twist it 5° . It then rapidly becomes more rigid, as the internal strains, so plainly indicated, are lost in this change of form, and at 6° of torsion the resistance becomes 60 foot-pounds, as measured at α . Here the elastic limit is reached. The next 3° produce no increase of resistance. This fact shows that this iron, which was not homogeneous as to strain, was also not homogeneous in structure. We conclude that it must be badly worked and seamy, and that it may have been rolled too cold; the former is the probable reason of its lack of homogeneous structure; the latter gave it its condition of internal strain. After the first 9° of torsion, resistance steadily rises to a maximum, which is reached only when just on the point of rupture, and the piece finally commences breaking at 250° , and is entirely broken off at 285° . Its maximum elongation, whose value is proportionable to the reduction of section noted with the standard testing machines, is 0.691.

The terminal portion of the line, after rupture commences, is not usually accurate as a measure of the relation of the force to the distortion. The increase of resistance between the angle 9° and the angle of rupture is produced by the additional effort in resistance due to the "flow," or drawing out of particles, as already indicated.

Applying the scale for tension, which in the case of these curves was very exactly 24,000 pounds per square inch for each inch measured vertically on the diagram, we find that the elastic limit was passed under a stress equivalent to a tension of 19,800 pounds per square inch, and that the ultimate tenacity was 59,200 pounds per square inch. When nearly at the maximum the specimen was relieved from stress, the pencil descending to the base line, and the elasticity of the piece produced a certain amount of recoil. The angle intercepted between the foot of this nearly vertical line, c , and the origin at O , measures the *set*, which is almost entirely permanent. The distance measured from the foot of the perpendicular let fall upon the axis of abscissas, from the head of this line to the foot of the line c , measures the elasticity, and is inversely proportional to the modulus. A comparison of the inclination of the line made by the pencil in reascending, on the renewal of the strain with the initial line of the diagram, gives the indication of the amount of internal strain originally existing in the piece.

It will be noticed that the horizontal movement of the pencil is recommenced at I , under a higher resistance than was recorded before the elastic line was formed. In this case the piece had been left under strain for some time before the stress was relieved, and the peculiarity noted is an example of an increase of resistance under stress,* or more properly of the elevation of the elastic limit, of which more marked examples will be shown subsequently.

The exceptional stiffness and limited elastic range here shown, as compared with the other examples given, is prob-

* *Vide* Transactions Am. Soc. C. E., Vol. II., page 290.

ably a phenomenon accompanying and due to this increase of resistance under stress.

Examining No. 1 in a similar manner, we find that it is far freer from internal strain than No. 6, its initial line being much more nearly straight and rising more rapidly. It is rather less homogeneous in structure, and is forced through an arc of 6° , after having passed its elastic limit, before it begins to offer an increasing resistance. It is evidently a better iron, but less well worked, and, as shown by the position of the elastic limit, is somewhat harder and stiffer. No. 1 retains its higher resistance quite up to the point at which No. 6 received its incidental accession of resistance by standing under strain, and the two pieces break at, practically, the same point; No. 1 having slightly the greater ductility. When the "elastic line," *e*, is formed just before fracture, it is seen that No. 1 has a greater elastic range and a lower modulus than No. 5. The elastic line formed by No. 1 at between 40° and 45° of torsion is seen to be very nearly parallel with that obtained near the terminal portion of the diagram, and illustrates the fact, here first revealed to the eye, that the elasticity of the specimen remains practically unchanged up to the point of incipient rupture; and this fact corroborates the deductions of Wertheim* and others who came to this conclusion from less satisfactory modes of research.

No. 22 illustrates the characteristics of a metal which represents one of the best qualities of wrought iron made, and with which every precaution has been taken to secure the greatest possible perfection, both in the raw material and in its manufacture. The line of this diagram, starting from *O*, rising with hardly perceptible variation from its general direction, turns, at the elastic limit, *a*, under a moment of about 80 foot-pounds, equivalent to a tension of about 24,000 pounds per square inch (1,680 kilogrammes per square cm.); and with between 2° and 3° of torsion only, and thence continues rising in a curve almost as smooth and reg-

* *Vide* Annales de Chimie et de Physique.

ular as if it had been constructed by a skilful draughtsman. Reaching a maximum of resistance to torsion of 220 foot-pounds and an equivalent tensile resistance of over 60,000 pounds per square inch (4,620 kilogrammes per square centimetre) at an angle of 345° , it retains this high resistance up to the point of rupture, some 358° from its starting point. The maximum elongation of its exterior fibres is 1.2, making them at rupture 2.2 times their original length. This would produce a probable breaking section in the common testing machine equal to 0.4545 of the original section.

From the beginning to the end this specimen exhibits its superiority, in all respects, over the less carefully made irons, Nos. 1 and 6, which are themselves good brands. The homogeneousness of No. 22 is almost perfect, both in regard to strain and to structure, the former being indicated by the straightness of the first part of the diagram and its parallelism with the "elastic line," e , produced at 217° , and the latter being proven by the accuracy with which the curve follows the parabolic path indicated by theory as that which should be produced by a ductile homogeneous material. At similar angles of torsion, No. 22 offers invariably much higher resistance than either Nos. 1 or 6, and this superiority, uniting with its much greater ductility, indicates an immensely greater resilience. It is evident that for many cases, where lightness combined with capacity to carry live loads and to resist heavy shocks are the essential requisites, this iron would be by far preferable, notwithstanding the cost of its manufacture, to any of the cheaper grades. Comparing their elasticities, as shown at 210° , 215° , it is seen that No. 22 is about equally stiff and elastic with No. 1, while both have a wider elastic range and are less rigid, and hence are softer, than No. 6, whose elastic line is seen at 221° . All of the characteristics here noted can be accurately gauged by measuring the diagrams.

No. 100 is the curve obtained from a piece of Swedish iron. Its characteristics are so well marked that one familiar with the metal would hardly fail to select this curve from among those of other irons. Its softness and its homogeneous

structure are its peculiarities. Its curve, at first, coincides perfectly with that of No. 6. It has, however, slightly less of the condition of internal strain, and a somewhat higher limit of elasticity. The elastic limit is found at $5\frac{1}{2}^{\circ}$ of torsion, and at a stress of 65 foot-pounds (9.1 kilogrammetres) of moment, equivalent to 19,500 pounds on the square inch (1,365 kilogrammes per square centimetre), in tension. Its increase of resistance, as successive layers are brought to their maximum and begin to flow, is very nearly the same as that of the specimens Nos. 1 and 6, and the line lies between the diagrams given by these irons up to 30° , and then falls slightly below the latter. At 220° it attains a maximum resisting power, and here the outer surface begins to rupture, after an ultimate stretch of lines formerly parallel to the axis amounting to 0.564. Had this elongation taken place in the direction of strain, as in the usual form of testing machine, it would have produced a reduction of section to 0.64 the original area.* At this point the stress in tension equivalent to the 176 foot-pounds (24.64 kilogram metres) of torsional stress, is 52,800 pounds per square inch (3,696 kilogrammes per square centimetre). From 250° the loss of resistance takes place rapidly, but the actual breaking off of the specimen did not occur until it had been given a complete revolution. This part of the diagram distinguishes the metal from all others, and shows distinctly the exceptionally tough, ductile and homogeneous character which gives the Swedish irons their superiority in steel making. No. 22, even, although much more extensible, is harder than No. 100, and yields more suddenly when it finally gives way.

280. Inspection of Fractured Test Pieces.—An examination of the broken test piece gives evidence confirmatory of the record. Thus, examining the broken test pieces from the autographic machine, as shown below, and comparing them, it will be found that the specimens themselves furnish almost as valuable information, after test, as the diagrams give, and they should always be carefully inspected with a

* Compare Styffe, *Strength of Iron and Steel*, p. 133, Nos. 26-30.

view to securing additional or corroborative information. Fig. 99 is a sketch of specimen No. 1, and shows its somewhat

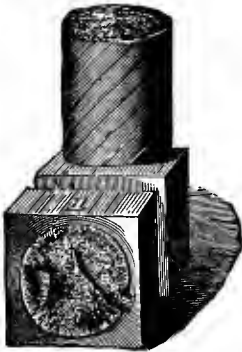

FIG. 99.



FIG. 100.

granular fracture, and the seamy structure produced by a defective method of working. Fig. 100, from specimen No. 16, more nearly resembles that which gave the diagram marked 6, Fig. 98. The metal is seen to be good, tough, and better in quality than No. 1, but it is even more seamy, and even less thoroughly worked, as is evidenced by the cracks extending around the neck, and by the irregularly distributed flaws seen on its end.



FIG. 101.

Fig. 101 exhibits the appearance of No. 22 after fracture, and shows, even more perfectly than the pencilled record, the excellent character of the material. The surface of the neck was originally smoothly turned and polished, and carefully fitted to gauge. Under test it has become curiously altered, and has assumed a rough, striated appearance, while the helical markings extend completely around it. The end has the peculiar appearance

which will be seen to be characteristic of tough and ductile

metals, and the uniformly bright appearance of every particle in the fractured section shows how all held together up to the instant of rupture, and that fracture finally took place by true shearing. Rupture by torsion thus brings to light every defect and reveals every excellence in the specimen. Rupture by tension rarely reveals more than the mere strength of the material.

281. Strain-Diagrams of Low Steels.—In Fig. 98, and above the curves just described, are a set obtained during experiments on “low steels,” produced by the Bessemer and Siemens-Martin processes. In general character the curves are seen to resemble those of the standard irons, as illustrated by Nos. 1 and 6. The irons contain usually barely a trace of carbon. These steels contain from one-third to five-eighths of one per cent. The irons are made by a process which leaves them more or less injured by the presence of impurities, from which the utmost care can never free them. The steels are made from metal which has been molten and cast, a process which allows a far more complete separation of slag and oxides. The low steels, however, are liable to an objectionable amount of porosity, due to the liberation of gas while the molten mass is solidifying, whenever the spiegeleisen, employed as a conveyer of carbon, carries little manganese. The results of these differences in constitution and treatment are readily seen by inspecting the curves. They show a stiffness equal to No. 6, and about the same degree of internal strain. They contain a sufficient number of the capillary channels produced by drawing down the pores while working the ingot into bar, to cause a lack of homogeneousness in structure very similar to that produced in iron by cinder. They have a much higher elastic limit and greater strength, and the softer grades have great ductility. In resilience, these softest steels excel all other metals, except the unusual example No. 22, and are evidently the best materials that are now obtainable for all uses where a tough, strong, ductile metal is needed to sustain safely heavy shocks. A comparison of the diagrams of two competing metals may thus be made to indicate how far a difference in

price should act as a bar to the use of the costlier one. For general purposes, a comparison of the resilience of the metals within the elastic limit is of supreme importance. No. 6 is seen to have more resilience within this limit than No. 1, and the steels far more than either; but No. 1 would take a set of considerable amount far within the true elastic limit, as indicated at *a*. The most valuable measure is obtained by determining the area intercepted between the "elastic line" and the perpendicular let fall from its upper end; this measures the resilience of elastic resistance, which is the really important quality.

No. 98 was cut from the head of an English Bessemer rail made from unmixed Cumberland ores. It contains nearly 0.4 per cent. carbon. It is quite homogeneous, has a limit of elasticity at 88 foot-pounds of torsional, or 26,400 pounds per square inch tensile stress, approaches its maximum of resistance rapidly, and at 210° the torsional moment becomes 225 foot-pounds, equivalent to 67,500 pounds per square inch tensile stress. It only breaks after a torsion of 283° , and with an ultimate elongation of 80 per cent., equivalent to a reduction of cross section to 0.556.

No. 76 is a Siemens-Martin steel made from mixed Lake Superior and Iron Mountain ores, and contained about the same amount of carbon as the preceding. It contains rather more phosphorus, which probably gives it its somewhat greater hardness, its higher limit of elasticity, and its somewhat reduced ductility. Its elastic limit is found at 104 foot-pounds of torsion, or 31,200 pounds tensile resistance, and its ultimate strength is almost precisely that of the preceding specimen. Its elongation is 0.66 maximum. Unless more seriously affected by extreme cold than No. 98, it would be preferred for rails, and, perhaps, for most purposes.

No. 67 is a somewhat "higher" steel, made by the same process. It is less homogeneous than the two just examined, has greater strength and a higher elastic limit, but less ductility. Its resilience is very nearly the same as that of Nos. 98 and 76. The elasticity of all these steels seems very exactly the same. The ductility of No. 67 is measured by

0.40 elongation. At *d*, is seen another illustration of elevation of the elastic limit. The piece was left twenty-four hours under maximum stress. The torsional force was then removed entirely. On renewing it, as is seen, the resistance of the specimen was found increased in a marked degree.

No. 69 is an American Bessemer steel, containing not far from 0.5 per cent. carbon. The same effect is seen here that was before noted, an increase of hardness, a higher elastic limit, and greater strength, obtained, however, by some sacrifice of both ductility and resilience. The elastic limit is approached at 130 foot-pounds of torsional moment, or 39,000 pounds tensile, and the maximum is 280 foot-pounds of moment and 84,000 pounds tensile resistance at 133° . Its maximum angle of torsion is 150° , its elongation 0.24.

No. 85 is a singular illustration of the effects of what is probably a peculiar modification of internal strain. It seems to have no characteristics in common with any other metal examined. Its diagram would seem to show a perfect homogeneousness as to strain, and a remarkable deficiency of homogeneity in structure. It begins to exhibit the indications of an elastic limit at *a*, under a torsional moment of 110 foot-pounds, or an apparent tensile stress of 33,000 pounds per square inch, and then rises at once, by a beautifully regular curve, to very nearly its maximum at 16° , and 176 foot-pounds. The maximum is finally reached at 130° , and thence the line slowly falls until fracture takes place at 195° . The maximum resistance seems* to be very exactly 60,000 pounds to the square inch. Its maximum elongation for exterior fibres is about 0.23. The resilience, taken at the elastic limit, is far higher than with common iron, and it is seen that this metal, in many respects, may compete with steel. Its elasticity was seen to remain constant wherever taken. This specimen was a piece of "cold-rolled" iron. It is probably really far from homogeneous as to strain, but its artificially pro-

* In exceptional cases, of which this is an example, this scale for tension gives too high values. The tensile strength is usually rather less than above given.

duced strains are symmetrically distributed about its axis, and being rendered perfectly uniform throughout each of the concentric cylinders into which it may be conceived to be divided, the effect, so far as this test, or so far as its application as shafting, for example, is concerned, is that of perfect homogeneity. The homogeneity in structure is readily explained by an examination of the pieces after fracture; they are fibrous, and have a grain as thread-like as oak; their condition is precisely what is shown by the diagram, and the metal itself is as anomalous as its curve.

282. Strain Diagrams of Tool Steels.—The “tool steels” differ chemically from the “low steels” in containing a higher percentage of carbon, and usually in being very nearly, though not absolutely, free from all injurious elements. Containing a higher proportion of carbon than the preceding class of metals, it is comparatively easy to secure homogeneity by the introduction of manganese, and, by the same means, to eliminate very perfectly the evil effects of any small proportion of sulphur that may be present. Their comparatively large admixture of carbon makes them harder and reduces their ductility, and since the reduction of ductility occurs to a greater degree than the increase of strength, the effect is also to reduce their resilience. The working of these metals is more thorough than is that of the less valuable steels or of iron. They are cast in comparatively small ingots, and are frequently drawn down under the hammer, instead of in the rolls, and are thus more completely freed from that form of irregularity in structure noticed so invariably in steels otherwise treated. The effect of increasing the proportion of carbon is to confer upon iron the property of hardening when heated to a high temperature and suddenly cool, and the invaluable property of “taking a temper.” The hardened steels are, however, comparatively brittle, the hardening being secured at the expense of ductility.

Referring to the figure, a set of diagrams will be found, having their origin at 180° , which are *fac-similes* of those automatically produced during experiments upon various kinds of tool steels.

No. 58 is an English metal, known in the market as "German crucible steel." It is remarkable as having a condition of internal strain which has distorted its diagram to such an extent as to completely hide the usual indication of the elastic limit. A careful inspection shows what may be taken for this point at about $14\frac{1}{2}^{\circ}$ of torsion, when the twisting moment was about 120 foot-pounds, and the tensile resistance 36,000 pounds per square inch (2,531 kilogrammes per square millimetre). The metal is homogeneous in structure, has an ultimate resistance of 302 foot-pounds of moment, or 90,600 pounds per square inch tensile resistance (6,369 kilogrammes per square millimetre). Its resilience is evidently inferior to that of the softer metals, and also less than the next higher and better grades. This metal contains about 0.60 to 0.65 per cent. carbon. Its elongation amounts to 0.045.

No. 53 is an English "double shear steel," of evidently very excellent structure, but less strong and less resilient than the preceding. Its exterior fibres are drawn out three per cent.

Nos. 41 and 61 are two specimens of one of the best English tool steels in our market. The first was tested as cut from the bar, but the second was carefully annealed before the experiment. In this instance annealing has caused a slight loss of resilience as well as a decided loss of strength. In No. 41 the limit of elasticity can hardly be detected, but seems to be at about the same point as in No. 61, at near 130 foot-pounds moment, and 39,000 pounds tension. The ultimate strength is nearly 119,000 pounds per square inch. The proportion of carbon is very closely 1 per cent. Its section would reduce by tension 0.05.

No. 70 is an American "spring steel," rather hard, but, as shown by its considerable resilience, of excellent quality, resembling remarkably the tool steel No. 41. It differs from the latter apparently by its much higher elastic limit. It is possible that this may have been caused by more rapidly cooling after leaving the rolls in which it was last worked. It is evident that, for exact comparison, all specimens should be

either equally well annealed, or should be tempered in a precisely similar manner and to the same degree.

Nos. 71 and 82 are American tool steels containing about 1.15 per cent. of carbon. The former is notable as having an elastic limit at 69,000 pounds and a probable deficiency of manganese, producing the usual indication of heterogeneous structure. Both of these steels lack resilience, and are less well adapted for tools like cold chisels, rock drills, and others which are subjected to blows, than for machine tools. They have a maximum elongation, respectively, of but 0.013 and 0.03.

283. Inspection of Steel Test Pieces.—Interesting and instructive as the study of these curves may be made, the information obtained from them is supplemented, in a most valuable manner, by that obtained by the inspection of the fractured specimens, upon which the peculiar action of a torsional strain has produced an effect in revealing the structure and quality of the metal that could be obtained in no other way.

Fig. 102 represents the appearance of No. 68, and Fig. 103 that of No. 58, while the peculiarities of the finest tool steels



FIG. 102.

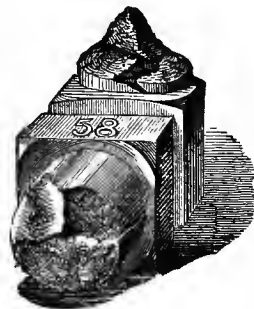
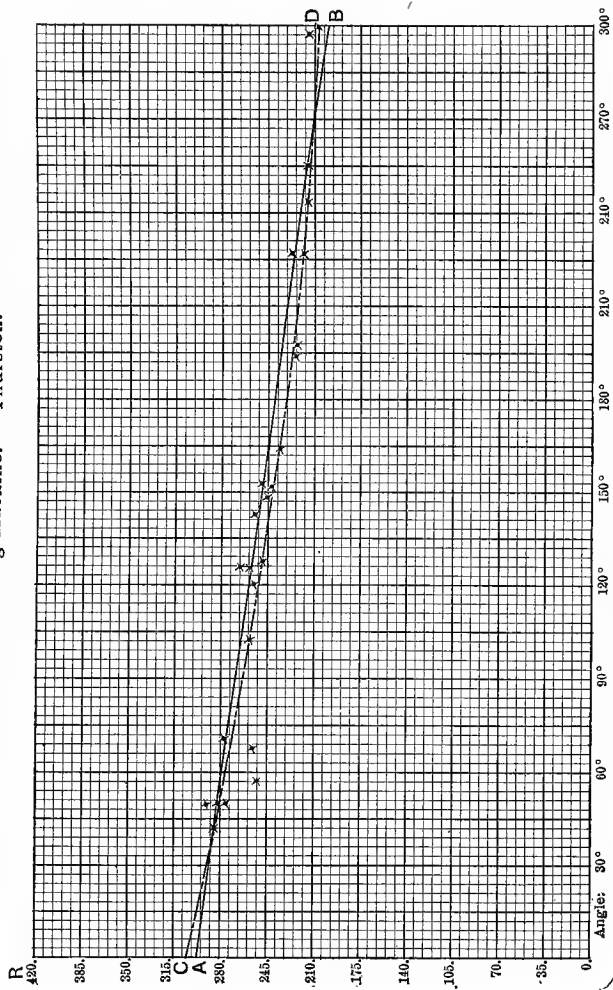

FIG. 103.

are seen in No. 71 as shown in Fig. 104. The smooth exterior of No. 68, which is a companion specimen to that giving diagram No. 69, and its bright and characteristic fracture,

RELATION OF TENSILE TO TORSIONAL RESISTANCES.*

For Steel; $R = \text{ratio of tenacity, lbs. per sq. in., torque in ft.-lbs., as determined for the "Autographic Recording Machine."} - \text{Thurston.}$



AB is a straight line. CD is an arc of a parabola.

* From Trans. A. S. C. E., July, 1878, No. clixiii.—R. H. T.

[To face page 544.]

resembling that of No. 22 somewhat, together indicate its nature perfectly, the first feature proving its strength and uniformity of structure, and the second showing, even to the inexperienced eye, its toughness. This is a representative specimen of low steels. No. 58 is seen to have retained, even more than No. 68, its original smoothly polished surface. Its fracture is less waxy, and much more irregular and sharply angular. The crack running down the side of the neck shows its relationship to the shear steels, which much oftener exhibit this effect of strain, in consequence of their lamellar character. No. 58 is evidently intermediate in its character between the soft steels, like No. 68, and the tool steels which are represented by No. 71, Fig. 104. In this test-piece the fracture is ragged and splintery, and the separated surfaces have a beautifully fine, even grain, which proves the excellence of the material. The surface, which was turned and polished in bringing the metal to size, remains as perfect as before the specimen was broken. By an inspection of the broken test pieces in this manner, the grade of the steel, and

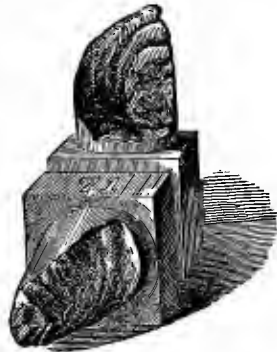

FIG. 104.

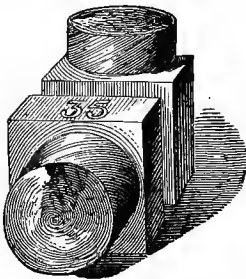

FIG. 105.

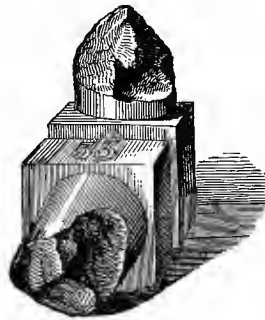

FIG. 106.

such properties also as are not revealed by an examination

of the diagram of strain, are very exactly ascertained by a novice, and, to the practiced eye, the slightest possible variations are readily distinguishable.

Fig. 105 shows the appearance of fracture of malleableized cast iron. Its semblance to wrought iron is very noticeable.

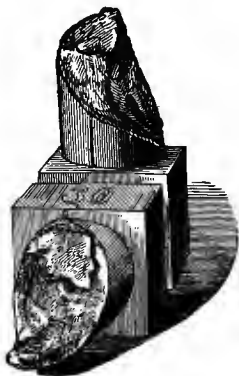

FIG. 107.

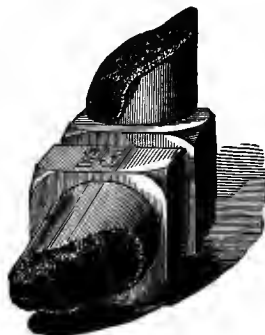

FIG. 108.

The lines running like the thread of a screw around the exterior of the neck, and the smooth, even fracture in a plane precisely perpendicular to the axis, are the instructive features. Fig. 106, representing No. 33, is a specimen similar in character to No. 37. The comparative lack of ductility, its less regular structure, and its less perfect transformation, are perfectly exhibited. Fig. 107 is an excellent cut of the white iron as cast and without malleableizing. Its surface, where fractured, has the general appearance of broken tool steel. The color and texture of the metal are distinctive, however. It has none of the "steely grain." Fig. 108 represents dark-gray cast iron. Its color, its granular structure and coarse grain, are markedly characteristic, and no one can fail to observe in the specimen the general character which is exactly given by the autographic diagrams of the testing machine.

284. Fractured Surfaces of Tension Test pieces.—The appearance of the fracture of good iron broken by tension

varies greatly with the rate of fracture. When broken slowly it should resemble that shown in Fig. 115, of Art. 287; fractured rapidly it may become like that seen in Fig. 116 of the same article. Fig. 109 represents the appearance of a surface of slightly cold-short, but otherwise excellent iron, forged in a large mass and broken suddenly.



FIG. 109.—FRACTURE OF MASSIVE IRON.

The following is the record, and illustrates well the loss of tenacity due to forging in large sizes :

TABLE CI.

TESTS MADE AT WATERTOWN ARSENAL, MASS., OF PIECES OF BEAM STRAP.

NUMBER.	LENGTH. INCHES.	GAUGED LENGTH. INCHES.	WIDTH.	THICKNESS.	SECT'AL AREA.	PERCENTAGE OF ELONGATION.	CON. OF AREA PER CENT.	LOAD APPLIED.	LBS. PER SQ. INCH.	ELASTIC LIMIT.	CLASSIFICATION OF FRACTURE.
1	Abt. 52	20	4.80	1.88	9.02	4.3	...	370,200	41.042	31,170	Granular.
2	" 52	20	4.80	1.74	8.35	4.	3.1	325,500	38,980	25,750	Granular from fine to coarse
3	" 52	20	4.82	1.97	9.55	16.6	383,000	40,320	26,320	Fibrous.	
4	" 52	20	4.75	2.07	9.83	7.	371,500	37,790	28,990	Granular, 90 %.	
5	" 52	20	4.75	1.67	7.93	8.2	16.8	338,000	42,620	26,480	Fibrous, 10 %.
6	" 52	20	4.75	1.74	8.26	2.2	11.1	281,000	34,020	28,450	Fibrous, 80 %.
											Granular, 10 %.

Nos. 1, 2, 3 were part of top of beam. Area, $5\frac{1}{8} \times 6\frac{1}{4}$ Average strength per square inch = 40,114 lbs. (2,820 kilogrammes per square centimetre). Average elastic limit per square inch = 27,747 lbs. (1,951 kilogrammes per square centimetre).

Nos. 4, 5, 6 were part of bottom member of strap. Average strength per square inch, 38,143 lbs. (2,681 kilogrammes per square centimetre). Average elastic limit per square inch, 27,973 lbs. (1,967 kilogrammes per square centimetre). Average strength per square inch of 1, 2, 3, 4, 5, and 6 = 39,129 lbs. (2,751 kilogrammes per square centimetre). Average elastic limit per square inch of 1, 2, 3, 4, 5, and 6 = 27,860 lbs. (1,959 kilogrammes per square centimetre).

This iron contained about 0.25 per cent. phosphorus and less than 0.1 per cent. carbon, and represents what would be considered an excellent sample of "phosphorus-iron."



FIG. 110.



FIG. 111.—FACES OF FRACTURE OF TEST-PIECE.

Figs. 110 and 111 exhibit the fracture of test pieces cut

out across the grain, and show the tearing of fibre from fibre which takes place in such cases.*

FACES OF FRACTURE.



FIG. 112.



FIG. 113.

Figs. 112 and 113 show the fractured surfaces of test pieces cut from the same mass, and may be compared with the two illustrations just referred to (Art's. 284, 287) as representing the break of slowly and quickly ruptured fibrous iron.

One of the most difficult problems in metallurgy is the provision of a steel combining high tenacity and elastic limit with good ductility. The requirement is illustrated in the manufacture of barrels for army rifles employing smokeless powders. Elastic limits above 75,000 pounds per square inch and elongations of 12 per cent. have been called for. The prescription for U. S. rifle-barrels has been: elastic limit 70,000 to 75,000 with tenacity of 100,000 to 120,000, elongation from 15 to 20 per cent. and contraction of section of 35 to 45 per cent. A steel which complies with these demands and also works well in the gun-making machines has C, 0.50; Mn, 0.80 to 1.00; Si, 0.10 to 0.18; and S and P not above 0.08 and 0.06 per cent. respectively. These specifications may be met by either Bessemer, open-hearth or crucible steel, and probably by the class of alloys which includes the "self-hardening steels."

The lower the temperature at which these steels are rolled the higher their working quality. Rolling at about 1000° F. and annealing at a slightly lower figure will usually give on the whole the best results.† Oil-tempering does not add to the tenacity or ductility of these steels.

* Mechanics, 1882, p. 245.

† Report of U. S. Bureau of Ordnance, 1900.

CHAPTER X.

TEMPERATURE AND TIME AS MODIFYING RESISTANCE ; FLOW OF METALS ; FATIGUE ; WOHLER'S LAW ; LAUNHARDT'S FORMULA.

285. The Effect of Heat and of variations of temperature upon the mechanical properties of metals has long been a subject of debate, and one which has not yet been satisfactorily settled by experiment.*

In general, it would appear that, in a perfectly homogeneous material, entirely free from internal strain, change of temperature would produce an alteration of strength and of ductility which would both be the reverse in direction of the variation of temperature.

The forces acting to produce mechanical changes being cohesive force, on the one hand, resisting external forces tending to produce distortion or rupture, while the force produced by the energy of heat-motion conspiring with external force to produce that distortion, and the molecules being at every instant in equilibrium between the force of cohesion on the one side, and the sum of the other two forces mentioned on the other, variations of form must ensue with every change in the relative magnitudes of these forces. A change of temperature produced by an increment of heat energy produces a reduction of cohesion by separation of particles, and the opposite change must cause an increase of cohesion by their approximation. Increase of temperature, by reducing the range of action of cohesion, by separating the particles and causing them to approach the limit of reach of cohesive force, reduces ductility, and the opposite change of temperature increases extensibility. The effect on resilience,

* This chapter contains some new matter and some extracted from a paper read by the Author before the Am. Society of Civil Engineers, 1874, and from a paper "On Molecular Changes in Iron," published in the *Iron Age*, 1873.

the product of ductility and strength, should, apparently, be still more marked than the variation of its factors.

The peculiar behavior of zinc, and the often observed brittleness of iron, at low temperatures, have given cause for doubting the truth of the above propositions; and until the phenomena accompanying variations in homogeneousness of structure and composition, and the introduction or removal of internal strain, have been very thoroughly investigated, it cannot be anticipated that the subject will become well understood. The character of polarity, that force of which the presence constitutes the distinguishing difference between solids and liquids, remains to be determined, and its determination may be expected to throw important light upon this subject.

Experiments of both physicists and engineers have failed, up to the present time, to give as much and as precise information as is needed to determine satisfactorily what rules should govern the proportions of structures, whether carrying dead loads or subjected to shocks or blows, at any given temperature below the usual range, or even at the low temperatures to be met during every winter in the latitude of New York or of London.

A committee of the Franklin Institute, of the State of Pennsylvania, consisting of Professor W. R. Johnson, Benjamin Reeves, and Professor A. D. Bache, were engaged during a period extending from April, 1832, to January, 1837, in experiments upon the tenacity of iron and of copper, under the varying conditions of ordinary use.

The experiments upon wrought iron were 73 in number, at temperatures between 212° and $1,317^{\circ}$ Fahr. (100° and 708° Cent.), and comparisons were made with the strength of the same bars at ordinary temperatures, as determined by 163 experiments.

This investigation disclosed the remarkable anomaly of the existence of a point in the scale of temperatures, usually, if not invariably, considerably above that of ordinary temperature, at which the metal exhibits a maximum of tenacity.

By heating a number of bars to 572° Fahr. (300° Cent.),

which was found to be very nearly the average temperature of maximum strength, and breaking them at that temperature, it was found that a mean of experiments, on the best qualities of rolled iron, gave this maximum as 15.17 per cent. higher than the tenacity of the same samples at ordinary temperatures.*

Taking 80° Fahr. (27° Cent.) as a standard temperature, the committee discovered that the fifth power of the diminution of tenacity from the maximum, determined as just stated, varied as the thirteenth power of the temperature above 80° Fahr., or

$$D^5 = C(T - 80^\circ)^{13},$$

where D = diminution of tenacity, T = temperature, C = a constant. At the temperature of about 400° and 1,200° Fahr. (204°, 649° Cent.), a marked departure from the curve took place, as already stated, the deviation from the law expressed by the formula becoming quite marked. About 1,100° Fahr. (593° Cent.), the loss of strength had a mean value of about 15 per cent., while at a welding heat it averaged nearly 25 per cent. In testing old boiler plate, a loss of strength by annealing was supposed to have been proven which amounted to about six per cent. The following are the tabulated results:

TABLE CII.
EXPERIMENTS FRANKLIN INSTITUTE, 1839.

CENT.	FAHR.	DIMINUTION P. C. OF MAX. TENACITY.	CENT.	FAHR.	DIMINUTION P. C. OF MAX. TENACITY.
271°	520°	0.0738	440°		0.2010
299		0.0869	500	932°	0.3324
311		0.0899	508		0.3593
316		0.0964	554		0.4478
332	630	0.1047	599		0.5514
350		0.1135	624	1,154	0.6000
378		0.1436	626		0.6011
389	732	0.1491	642		0.6352
390		0.1535	669		0.6622
408		0.1589	674	1,245	0.6715
410		0.1627	708	1,306	0.7001

* Report of Committee, p. 213.

A somewhat similar series of experiments was made by Sir Wm. Fairbairn upon rolled iron,* and the same behavior was noted, under varying temperatures, so well shown by the earlier researches of the committee of the Franklin Institute.

The tenacity of Staffordshire boiler plate was examined at temperatures varying from 0° Fahr. (− 18° Cent.) to a dull red heat—probably 1,000° Fahr. (538° Cent.). This iron is not of high quality, and some marked deviations were observed from the general direction of alteration of strength. The tenacity of the specimens gradually increased, as the temperature rose from 60° to 395° Fahr. (15° Cent. to 202° Cent.), and thence diminished, until at a red heat, the strength became reduced to the extent of 25 per cent. The tenacity recorded at 0° Fahr. (− 18° Cent.) was, however, 6 per cent. greater than the *mean* noted at any other observed higher temperatures, but not greater than that of individual specimens.

Other experiments were made upon rivet iron, which was necessarily of better quality than the Staffordshire plate. The tabular statement of the results shows a gradual and quite regular increase of tenacity from 60° to 325° Fahr. (15° to 163° Cent.), the strength being given at 68,816 and 84,046 pounds per square inch (4,837 to 6,008 kilogrammes per square centimetre) at those points respectively—a difference of 30 per cent. The tenacity then diminished as temperature rose, becoming reduced to 32,000 pounds per square inch (2,461 kilogrammes per square centimetre) at a red heat. The strength at 30° Fahr. (− 1° Cent.) was slightly greater than at ordinary temperatures, the figure given being 63,238 pounds per square inch (4,445 kilogrammes per square centimetre).

Experiments made by Fairbairn on the effect of temperature upon cast iron give less uniform results. †

Mr. Fairbairn remarks: ‡ “On the whole, we may infer

* British Association Report, 1856.

† British Association Report, vol. 6, 1837.

‡ On the Application of Wrought and Cast Iron to Building Purposes : London, 1844, p. 66.

that cast iron, of average quality, loses strength when heated beyond a mean temperature of 120° Fahr. (49° Cent.), and that it becomes insecure at the freezing point, or under 32° Fahr. (0° Cent.)." He supposed that the fact that, in some experiments, he found No. 3 iron to increase in strength with rising temperature, is due to its great "irregularity and rigidity."

David Kirkaldy, of Glasgow, in December, 1860, while conducting one of the most extended, accurate, and well-arranged experimental inquiries into the value of the tenacity of iron and steel that has yet been made,* took occasion to examine the action of frost upon them.

"A bar of Glasgow B, best $\frac{3}{4}$ -inch diameter, was converted into ten bolts, in the ordinary way. Six were exposed all night to intense frost, and tested in the morning with the thermometer at 23° Fahr. (5° Cent.). The others were kept in a warm place, and carefully protected during testing. Three were tested with gradual, and seven with sudden strains." When the strain was gradually applied there was very little difference between the specimens tested in the ordinary condition and the two that were frozen; the former bore 55,717, the latter 54,385 (3,817 and 3,813 kilogrammes per square centimetre), or 2.1 per cent. less. The difference under sudden strains is somewhat greater, viz., 3.6 per cent. less when frozen." This iron was of good quality, and Kirkaldy remarks that "had it been of a coarser description, the difference, when frozen, might have been much greater." He concludes† that "the breaking strain is reduced when the iron is frozen; with the strain gradually applied, the difference between a frozen and an unfrozen bolt is lessened as the iron is warmed by the drawing out of the specimen."

Mr. William Brockbank has described experiments made for the purpose of determining the effect of cold upon the cohesion of cast iron. Using a mixture of several irons of

* Experiments on Wrought Iron and Steel. David Kirkaldy, Glasgow, 1863, p. 85.

† Ibid, p. 95.

quite different qualities (Cleator red hematite, Pontypool and Blaenavon cold-blast, and Glengarnock hot-blast irons, with scrap added), he found a perceptible decrease of strength with decrease of temperature. He noted a similar effect where wrought iron was used. The experience of well-known iron masters was adduced in corroboration of these conclusions, the examples being, usually, instances of breakage by *shock*. The conclusion of the experimenter* was that "bar iron, boiler plate, wire billets, and rails, are most materially weakened by the action of intense cold, losing their toughness, becoming quite brittle under sudden impact, and having their structure changed from fibrous to crystalline."

Fairbairn attributes the more frequent breaking of wheel tires in cold weather to unequal strains due to shrinkage, rather than to loss of tenacity.

Dr. Joule concludes that "frost does *not* make either iron (cast or wrought) or steel brittle, and accidents arise from the neglect of the companies to submit wheels, axles, and all other parts of their rolling stock to a practical and sufficient test before using them."

Mr. Peter Spence experimented upon bars of cast iron one half inch square (1.27 centimetres), placed on supports nine inches (22.86 centimetres) apart, and broken by carefully applied and steady pressure.

Six experiments were made at 60° and six at 0° Fahr. (+ 15° and - 18° Cent.). He sums up the evidence thus: "The bars at zero broke with more regularity than at 60°, but instead of the results confirming the general impression as to cold rendering iron more brittle, they are calculated to substantiate an exactly opposite idea, namely, that reduction of temperature, *cæteris paribus*, increases the strength of cast iron." He found this increase to amount to 3½ per cent. between 60° and 0° (+ 15° and - 18° Cent.).

Subsequently Mr. Spence made a more extended series of experiments. He obtained 50 bars of cast iron (of mixed Scotch brands), each 3 feet (0.91 metre) long, and ½ inch

* *Nature*, 1871.

(1.27 centimetres) square, cut them into lengths of one foot (0.304 metre), and mixed them thoroughly. Seventy pieces were tested at zero, after 48 hours' exposure to a freezing mixture of salt and ice, and 70 were tested at 70° Fahr. (21° Cent.). The breaking weights of the pieces averaged 430.3 pounds (19.1 kilogrammes) warm, and 442.8 pounds (20.1 kilogrammes) at zero, the weight being placed midway between supports 9 inches apart.

Mr. Spence finally says: * "I have no hesitation in giving it as an ascertained law that a specimen of cast iron having at 70° Fahr. a given power of resistance to transverse strain, will, on its temperature being reduced to 0°, have that power increased 3 per cent."

286. Experiments of Styffe and Sandberg.—The most complete investigation ever made, particularly to determine the effect of changes of temperature in modifying the physical properties of iron and steel, was that of Knuff Styffe, the director of the Royal Technological Institute at Stockholm, Sweden, and supplemented by the experiments of Christer P. Sandberg, who translated the report of Styffe into English. The work of the first-named engineer was done at the instance of a committee appointed by the King of Sweden. It was commenced by Professor Angstrom, continued by Herr R. Thalen, of the University of Upsala, and by Engineer K. Cronstrand, and it was finally concluded, with the assistance of Cronstrand and Lindell, by Styffe, who wrote out the results of the whole investigation and made the report public. These labors were begun in 1863, and extended over several years.

The conclusions of Styffe were :

"(1.) That the strength of iron and steel is not diminished by cold, but that, even at the lowest temperature which ever occurs in Sweden, it is at least as great as at ordinary temperature (about 60° Fahr., 15° Cent.).

"(2.) That, at temperatures between 212° and 392° Fahr. (100° and 200° Cent.), the strength of steel is nearly the

* *Engineering.* London, 1871. Vol. II., p. 172.

same as at ordinary temperature, but in soft iron is always greater.

“(3.) That neither in steel nor in iron is the extensibility less in severe cold than at ordinary temperature, but that, from 266° to 320° Fahr. (130° to 160° Cent.), it is generally diminished, not to any great extent in steel, but considerably in iron.

“(4.) That the limit of elasticity in both steel and iron lies higher in severe cold, but that at about 284° Fahr. (140° Cent.), it is lower, at least in iron, than in ordinary temperatures.

“(5.) That the modulus of elasticity in both steel and iron is increased on reduction of temperature and diminished on elevation of temperature, but that these variations never exceed 0.05 per cent. for a change of temperature of 1.8° Fahr. (1° Cent.), and therefore that such variations, at least for ordinary purposes, are of no special importance.”

An equally well conducted series of experiments on transverse strength and the flexure of iron and steel, led to the following conclusions:

“(1.) Iron sustains at lower temperatures a greater, and at higher a smaller load than at the ordinary temperature, before it obtains any perceptible permanent deflections.

“(2.) The modulus of elasticity for steel and iron for flexure may, for practical purposes, and without committing any considerable error, be generally assumed equal to that for tension. It is diminished by permanent deflection, but may be restored by heating, especially if raised to a red heat.

“(3.) By hardening steel its modulus of elasticity is diminished, but this diminution has not, in any of the hardened bars examined, amounted to more than about 3 per cent.”

“(4.) The elastic force of iron and steel on flexure, as in tension, is increased on reduction of temperature, and diminished on elevation of temperature. The amount of this increase or decrease for a change of temperature equal to 1.8° Fahr. (1° Cent.) does not, however, in general amount to more than 0.03 per cent., and apparently never rises to 0.05 per cent.”

The experimenter states that “the results of the experi-

ments given above are evidently opposed to the opinion hitherto commonly entertained, viz., that steel and iron become weak or brittle at low temperatures," and gives it as his opinion that the cause of the frequent breakage of rails in cold weather, and of articles made of iron and steel, is unequal expansion and contraction and the rigidity of supports, where, as in the case with rails, frost may very greatly affect them.

Sandberg, while admitting the care and the accuracy which distinguished this extensive series of experiments, still doubted whether the reasons just given were the sole reasons why metals should more readily break in cold than in hot weather, and, having obtained the consent of the State Railway Administration, he conducted a series of experiments in the summer and winter of 1867, at Stockholm, to determine whether, with equal rigidity of supports, iron rails would yield with equal readiness to blows at the two extremes of temperature.

The rails experimented upon were each cut in halves, and one piece was tested in cold and the other warm weather, at temperatures of 10° and 84° Fahr. (− 12° and 29° Cent.), respectively. The supports at the end of the rails were granite blocks placed four feet (1.2 metres) apart, and resting on the smoothly levelled surface of the granite rock. They were broken by a heavy drop weighing 9 cwt. (409 kilogrammes).

Sandberg's conclusions from twenty experiments are thus given :

"(1.) That for such iron as is usually employed for rails in the three principal rail-making countries (Wales, France and Belgium), the breaking strain, as tested by sudden blows or shocks, is considerably influenced by cold, such iron exhibiting at 10° Fahr. (− 12° Cent.) only from one third to one fourth of the strength which it possesses at 84° Fahr. (29° Cent.).

"(2.) That the ductility and flexibility of such iron is also much affected by cold; rails broken at 10° Fahr. (− 12° Cent.) showing, on an average, a permanent deflection of less

than one inch, whilst the other halves of the same rails, broken at 84° Fahr. (29° Cent.), showed a set of more than 4 inches before fracture.

“(3.) That at summer heat the strength of Aberdare rails was 20 per cent. greater than that of the Creusot rails, but that in winter the latter were 20 per cent. stronger than the former.”

Sandberg suggests that this considerable lack of toughness at low temperatures may be due to the “cold-shortness” produced by the presence of phosphorus.

287. Other Experiments.—Jouraffsky, of St. Petersburg, has reported* the results of tests of rails made for the Russian government, which supplement the preceding in a very valuable manner. It was found that by placing pieces of rail from 6 feet to 8 feet long in a mixture of ice and salt, the temperature of the rail could be lowered in a very short space of time, during warm weather, 36° Fahr. (20° Cent.) below freezing-point.

A special commission, Messrs. Erakoff, Beck, Guerhard, Nicolai, and Feodossieff, was appointed to carry out a series of tests on this plan. Pieces of rail 6 feet (1.8 metres) long were taken in pairs, one of which was tested at the natural temperature, the others being placed in a box filled with a mixture of two parts of broken ice and one part of salt, and, after being cooled to a temperature of from $+3^{\circ}$ to -6° Fahr. (-16° to -21° Cent.), which occurred in half an hour, they were all submitted to the same tests. Altogether, 86 samples were tested, and these were, for the sake of comparison, divided into two groups, viz. : (1) Rails which broke under the test ; and (2) rails which stood the test.

The results indicated that the brittleness of the steel increases very much at low temperature if it contains more than a moderate amount of phosphorus, silicon, and carbon. The total of the three elements in the rails which broke under the test averages 0.54 per cent., and in those which stood the same test 0.41 per cent. ; the first average (0.54 per cent.) varying

* Communicated to the London meeting of the Iron and Steel Institute, 1879.

from 0.44 to 0.67 per cent., and the second average (0.41 per cent.) varying from 0.37 to 0.55 per cent.

The total of the three hardening elements are expressed in phosphorus units thus: For rails which stood the test, 19 units; for rails which broke under the same test, 31 units. In the first, the units vary from 16 to 22 (in one case only 25 being reached), and in the second, the difference was from 22 (and that only in two cases, all the others being higher) to 45 units. Reports from Russian railways have shown that 77 per cent. of the breakage of rails and tires occurs on those roads at a temperature below 32° Fahr. (0° Cent.).

The variation of strength of iron with rising temperature has been studied by Kollmann, using metal of the following composition:

	WELD-IRON.	WELD-IRON.	INGOT IRON.
C.....	0.10	0.12	0.23
Si.....	0.09	0.11	0.30
P.....	0.34	0.20	0.09
S.....	0.03	trace	0.05
Mn.....	0.07	0.14	0.86
Cu.....	0.07	0.06	0.07
Fe.....	99.30	99.36	98.40

These metals were rolled at temperatures varying from a maximum of 2,417° Fahr. (1,325° Cent.) at the roughing rolls, to 1,112° Fahr. (600° Cent.) as a minimum at the last pass. The results of the test of finished iron at various temperatures were the following, and the steel nearly the same in method of variation, although about 50 per cent. higher in tenacity at each point:

Temperature, {	Cent.....	0°	200°	300°	400°	600°	1,000°
	Fahr.....	32°	392°	572°	752°	1,112°	1,832°
Lbs. per sq. in.	53,300	52,600	47,900	38,950	9,860	112	
Tenacity, kgs. per sq. cm.	3,750	3,570	3,370	2,734	690	8	

The elastic limits decrease in nearly the same proportion. The extensions increase slowly up to the red heat.

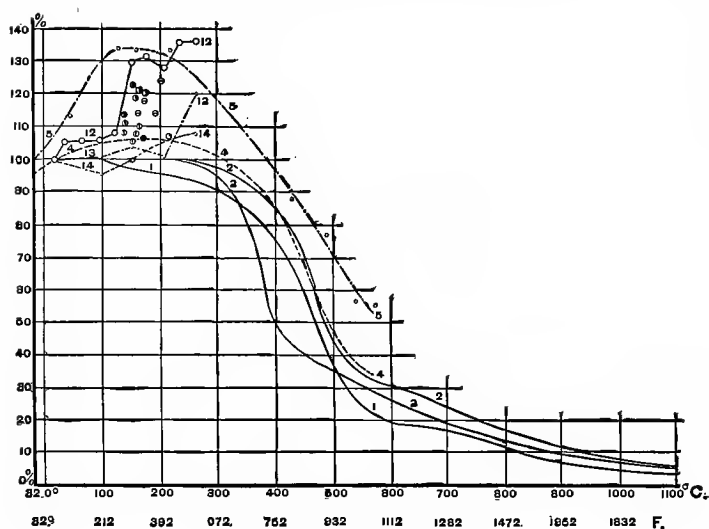

FIG. 114.—HEAT VS. TENACITY.

The diagram above* (Fig. 114) graphically represents the results of several series of experiments, some of which have just been described. It exhibits the general accordance of all later investigations with that of the Franklin Institute.

Curves Nos. 1 and 2 represent Kollmann's experiments on iron, and 3 on Bessemer "steel." No. 1 is ordinary, and 2 steely puddled iron.

Curve No. 4 represents the work of the Franklin Institute on wrought iron.

Curve No. 5 gives Fairbairn's results, working on English wrought irons.

Nos. 6 to 11 are Styffe's, and represent the experiments made by him on Swedish iron. The numbers do not appear, as these results do not fall into curves; these results are indicated by circles, each group being identified by the peculiar filling of the circles, as one set by a line cross-

* *Eisen und Stahl*, A. Martens; *Zeitschrift des Vereins Deutscher Ingenieure*; Feb. 1883, p. 127.

ing the centre, another by one across, a third by a full circle, etc.

The broken lines, 12 and 13, are British Admiralty experiments on blacksmiths' irons, and No. 14 on Siemens steel.

The first five series, only, are of value as indicating any law; and they exhibit plainly the general tendency already referred to, to a decrease of tenacity with increase of temperature.

Fairbairn's experiments, No. 5, best exhibit the maximum, first noted by the Committee of the Franklin Institute, at a temperature between that of boiling water and the red heat.

It will be observed that the measure of tenacity, at the left, is obtained by making the maximum of Kollmann unity. It will also be noted that Kollmann does not find a maximum as in curves 4 and 5, but, on the contrary, a more rapid reduction in strength at that temperature than beyond.

It would seem, therefore, that that peculiar phenomenon must be due to some accidental quality of the iron. The Author has attributed it to the existence in the iron, before test, of internal stresses which were relieved by flow as the metal was heated, disappearing at a temperature of 300° or 400° Fahr. (149° to 204° Cent.).

A singular modification of set by change of temperature was noted while testing springs in the mechanical laboratory of the Stevens Institute of Technology; * tested at 32° Fahr. (0° Cent.) the set of a coil of $\frac{5}{8}$ inch (1.59 centimetres) wire, twenty inches (50.8 centimetres) long, after a compression of $3\frac{1}{2}$ inches (8.9 centimetres) under a load of 5,000 pounds (2,268 kilogrammes) was 0.188 inch (0.48 centimetre), while at 212° Fahr. (100° Cent.) it was but 0.016 inch (0.04 centimetre).

The experiments of Mr. Oliver Williams,† in determining the change produced in the character of the fracture of iron by transverse strain, at extreme temperatures, indicate loss of ductility at *low* temperatures.

Two specimens of nut iron, from different bars, made at

* *Van Nostrand's Mag.*, 1878, p. 528. De Bonneville.

† *The Iron Age*, New York, March 13, 1873, p. 16.

Catasauqua, Pennsylvania, were first nicked with a cleft on one side only, and then broken under a hammer, at a temperature of about 20° Fahr. (− 7° Cent.). At this temperature, both specimens broke off short, showing a clearly defined granular, or steely iron fracture. The pieces were then gradually heated to about 75° Fahr. (24° Cent.), and then broken as before, developing a fine, clear, fibrous grain. The two fractures were but four inches (10.16 centimetres) apart, and are entirely different.



FIG. 115.—FRACTURE AT ORDINARY TEMPERATURE.

It has been long known that a granular fracture may be produced by a shock, in iron which appears fibrous when gradually torn apart. This was fully proven by Kirkaldy.* Mr. Williams was, probably, the first to make the experiment just described, and thus to make a direct comparison of the characteristics of fracture in the same iron at different temperatures.



FIG. 116.—FRACTURE AT LOW TEMPERATURE.

Valton has found † that some iron becomes brittle at temperatures of 572° or 752° Fahr. (300° to 400° Cent.), and regains ductility and toughness at higher temperatures. On the whole, the fracture of iron at low temperatures has been found to be charac-

* Experiments on Iron and Steel.

† *Bulletin Iron and Steel Assoc.*, Feb. 1877

teristic of a brittle material, while, at higher temperatures, it exhibits the appearance peculiar to ductile and somewhat viscous substances. The metal breaks, in the first case, with slight permanent set, and a short, granular fracture, and in the latter with, frequently, a considerable set, and the form of fracture indicating great ductility. The variation in the behavior of iron, as it approaches the welding heat, illustrates the latter condition in the most complete manner.

The effect of alteration of temperature upon cast iron has been less studied than its influence on the malleable metals. The few experiments made by the Author indicate greater susceptibility to the influence of heat than is observed in either wrought iron or steel. The accompanying diagram exhibits this comparison, as made by the use of the Autographic Testing Machine.*

In these experiments the testing machine was placed in the open air in mid-winter, and exposed with test piece under stress to temperatures falling as low as -10° Fahr. (-23° Cent.), and, again, taken indoors, and the tests continued at

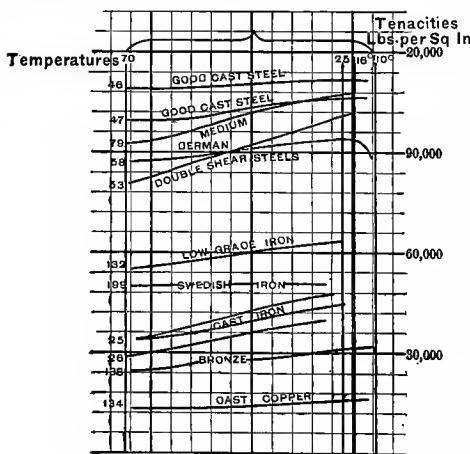

FIG. 117.—EFFECT OF COLD.

temperatures rising to $+70^{\circ}$ Fahr. ($+21^{\circ}$ Cent.). In the diagram, the horizontal scale at the top is a scale of temperatures, several points, as 70° , 25° , 18° , 10° , being marked; the vertical scale is one of tenacities. The several numbers attached at the extremities of the curves are those of the specimens tested. It will be noted that

* *Trans. Amer. Soc. C. E.*, 1874; *Jour. Franklin Inst.*, 1874. Vol. LXXVII., Pl. III.

cast iron shows greater loss of tenacity, at the higher temperatures than other metals, except a single piece of double shear steel.

Swedish iron seems almost unaffected, and cast copper is but slightly weakened. The effect of change of temperature is invariably, so far as observed, to produce a change of tenacity in the opposite direction, rise in temperature being accompanied by a decrease of strength and *vice versa*.

Valton found that a steel rod bent very well at a temperature a little below dull red, but broke at a temperature which may be called blue, the fracture showing that color. Portions of the rod which were below this temperature manifested much toughness, and bent without fracture. Charcoal pig iron from Tagilsk, made in 1770, irons obtained from the Ural in rods and sheets, soft Bessemer and Martin steels from Terrenoire, soft English steel and good English merchant bars, all gave the same results, whether the metal tested had been hammered or rolled. Valton found that the phenomenon had been long known to the workmen under his direction. In working sheet iron with the hammer, they wait until the metal had cooled further when approaching the temperature which would give the blue fracture when broken.

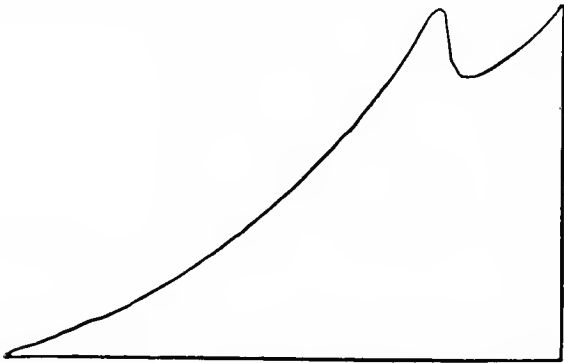

FIG. 118.—INCREASE OF VOLUME, 0° UP TO $2,776^{\circ}$ F., ($1,525^{\circ}$ C.).

He concludes that wrought iron, as well as some kinds of soft steel, even when of excellent quality, are very brittle at

a temperature a little below dull red heat— 577° to 752° Fahr. (between 300° and 400° Cent.).

The variation of strength follows quite closely the change of density, which latter is illustrated in the preceding diagram, which exhibits increase of volume from the freezing point.

The sudden fall of the line before reaching the melting point indicates the sudden increase of volume which castings exhibit while cooling, and which enables “sharp” castings to be secured. It is at the crest noted near this point that viscosity is observed. From this point back to the freezing point the variation follows a regular law.

288. Conclusions as to Effect of Change of Temperature.—It would thus seem that the general effect of increase or decrease of temperature is, with solid bodies, to decrease or increase their power of resistance to rupture, or to change of form, and their capability of sustaining “dead” loads; and we may conclude:

(1.) That the general effect of change of temperature is to produce change of ductility, and, consequently, change of resilience, or power of resisting shocks and of carrying “live loads.” This change is usually opposite in direction and greater in degree at ordinary temperatures than the variation simultaneously occurring in tenacity.

(2.) That marked exceptions to this general law have been noted, but that it seems invariably the fact that, wherever an exception is observed in the influence upon tenacity, an exception may also be detected in the effect upon resilience. Causes which produce increase of strength seem also to produce a simultaneous decrease of ductility, and *vice versa*.

(3.) That experiments upon copper, so far as they have been carried, indicate that (as to tenacity) the general law holds good with that metal.

(4.) That iron exhibits marked deviations from the law between ordinary temperatures and a point somewhere between 500° and 600° Fahr. (260° and 316° Cent.), the strength increasing between these limits to the extent of about 15 per cent. with good iron. The variation becomes more marked and the results more irregular, as the metal is more impure.

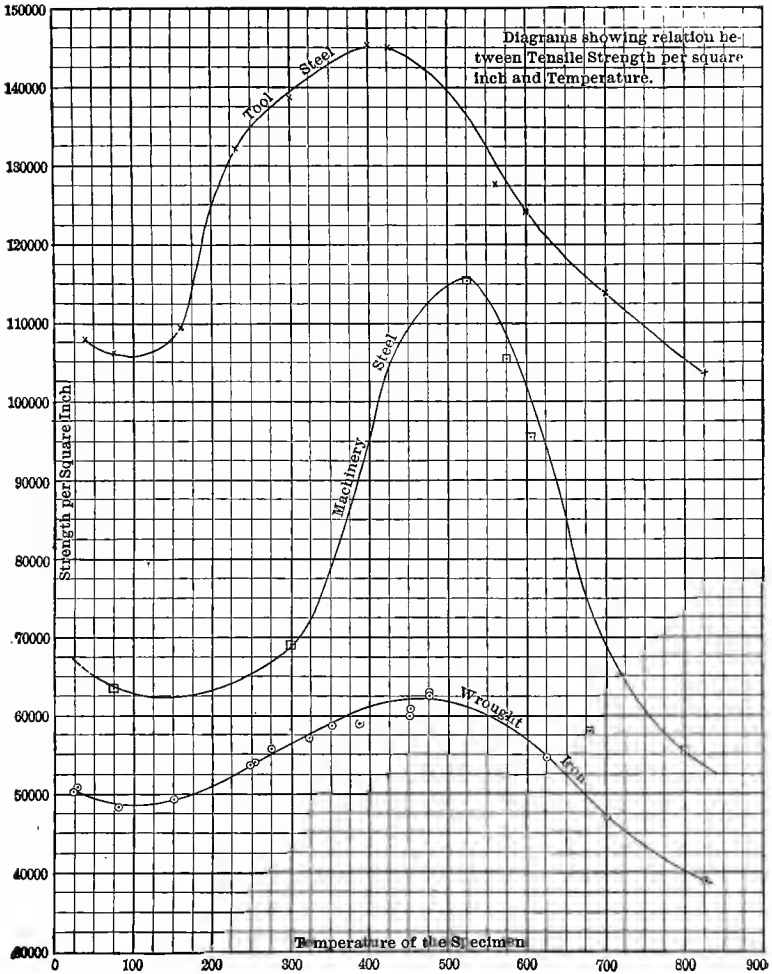

FIG. 118a.—TEMPERATURE AND TENACITY.
SIBLEY COLLEGE; CORNELL UNIVERSITY.

[To face page 567.]

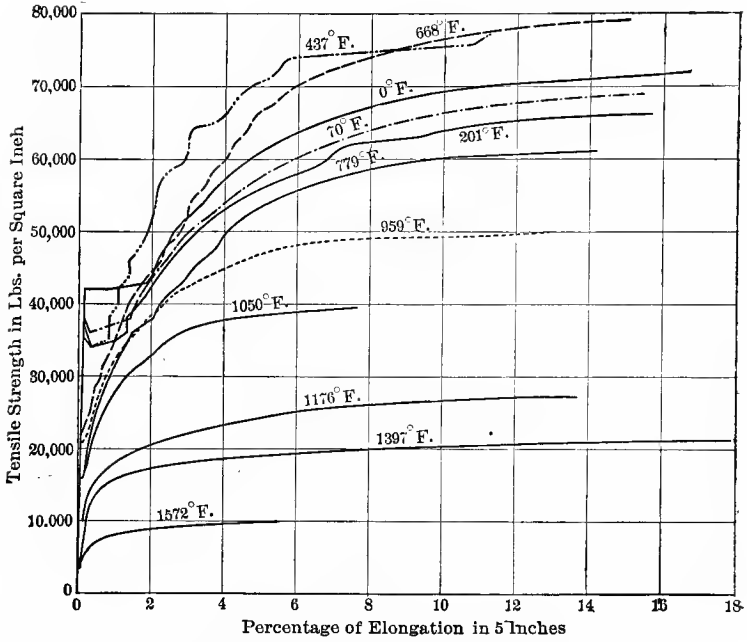

FIG. 1186.—TEMPERATURE AND TENACITY.

Steel Bars, 0.20 C, 0.45 Mn.—Watertown Arsenal, 1888.

(5.) That above 600° Fahr. (316° Cent.) and below 70° (21° Cent.), the general law holds good for iron, its tenacity increasing with diminishing temperature below the latter point at the rate of from 0.02 to 0.03 per cent. for each degree Fahrenheit, while its resilience decreases in an undetermined ratio, for good iron, and to the extent of reduction to one-third its ordinary value, or less, at 10° Fahr. (-12° Cent.) when cold-short, and, in the latter case, the set may be less than one-fourth that noted at a temperature of 84° Fahr. (29° Cent.).

(6.) That the viscosity, ductility, and resilience of metals are determined by identical conditions, and that the fracture of iron at low temperatures, has, accordingly, been found to be characteristic of a brittle material, while at the higher temperatures it exhibits the appearance peculiar to ductile and somewhat viscous substances. The metal breaks in the first case, with slight permanent set and a short granular fracture, and in the latter with frequently a considerable set and a form of fracture indicating great ductility. The variation in the behavior of iron, as it approaches a welding heat, illustrates the latter condition in the most complete manner.

(7.) That the precise action of the elements with which iron is liable to be contaminated, and the extent to which they modify its behavior under varying temperature, remain to be fully investigated, but that the presence of phosphorus and of other substances producing "cold-shortness," exaggerates to a great degree the effects of low temperature in producing loss of toughness and resilience.

(8.) That the modifications of the general law with other metals than iron and copper, and in the case of alloys, have not been studied, and are entirely unknown.

The practical result of the whole investigation is that iron and steel, and probably other metals, do not lose their power of sustaining absolutely "dead" loads at low temperatures, but that they do lose, to a very serious extent, their power of sustaining shocks or of resisting sharp blows, and that the factors of safety in structures need not be increased in the former case, where exposure to severe cold is

apprehended; but that machinery, rails, and other constructions which are to resist shocks, should have larger factors of safety, and should be most carefully protected, if possible, from extreme temperatures.

289. The Stress produced by Change of Temperature is easily calculated when the modulus of elasticity and the coefficient of expansion are known, thus :

- Let E = the modulus of elasticity ;
- λ = the change of length per degree and per unit of length ;
- Δt° = the difference of initial and final temperatures ;
- p = the stress produced, when rigidly confined.

Then :

$$p : E :: \lambda \Delta t^\circ : 1,$$

$$\therefore p = \lambda E \Delta t^\circ (1)$$

For good wrought iron and steel, taking E as 28,000,000 pounds on the square inch, or 2,000,000 kilogrammes on the square centimetre, and λ as 0.0000068 for Fahrenheit, and as 0.0000120 for Centigrade degrees :

$$\left. \begin{aligned} p &= 190 \Delta t^\circ \text{ Fahr., nearly} \\ &= 25 \Delta t^\circ \text{ Cent., nearly} \end{aligned} \right\} (2)$$

For cast iron, taking $E = 16,000,000$; $\lambda = 0.0000062$:

$$\left. \begin{aligned} p &= 100 \Delta t^\circ \text{ Fahr., nearly} \\ &= 12 \Delta t^\circ \text{ Cent., nearly} \end{aligned} \right\} (3)$$

The modulus is reduced by increasing temperature thus :

$$m = m_0(1 - at),$$

where, for centigrade scale, $a = 0.005$.

290. Sudden Variation of Temperature has an effect

upon steel which is very great when the proportion of carbon is not far from one per cent. With less carbon the effect is less observable, and with the wrought irons and with ingot metals containing less than one third per cent. carbon and other hardening elements, it becomes quite unimportant. Soft irons are still further softened by sudden reduction of temperature from the red heat. Cast irons, unless of the class known as "chilling irons," are much less affected than steel, and when very rich in graphitic carbon are not perceptibly hardened.

When either iron or steel is repeatedly heated and cooled, a permanent change of form takes place. Col. Clarke has shown* that cylinders repeatedly heated to a high temperature and suddenly cooled, become enlarged in diameter permanently. Pieces of tempered steel are larger than when untempered.

Cast-iron ordnance, after having been discharged many times, becomes unsafe in consequence of weakening, which is probably principally due to strains caused by sudden and irregular changes of temperature in service.

Such grades of steel as take a temper are greatly strengthened unless too highly hardened, in which case they become brittle from internal stresses. The Author has found tempering in mercury to increase greatly both the strength and the toughness of small pieces of good tool steel. Kirkaldy has found, by an extended series of experiments, that tempering tool steels in oil greatly increases both strength and elasticity, while hardening in water reduces both. The higher the temperature at which, without risk, the steel can be cooled, the greater is this increase of strength. Hard steels exhibit the fact better than soft steels. Dividing steels into series in the order of their contents in carbon, beginning with the softest grades, the following were the percentages of increase of strength from weakest to strongest: 11.8, 24.2, 40.7, 53.2, 57.0, 64.1, 70.9, 77.6. The harder steels were highly heated; the soft steels only moderately.

* *Philosophical Magazine*, 1863.

A set of samples of quite hard steel plate were tested at various grades of hardening, and gave the following rates of increase, beginning with the hardest: 56.4, 43.7, 40.6, 38.1, 30.0, 12.8. Such plates hardened in oil and riveted together with rivets of similar metal were as strong at the joint as the untempered steel in the body of the plate. Three pieces of tool steel gave confirmatory results. Unhardened, one had a tenacity of nearly 125,000 pounds per square inch (8,788 kilogrammes per square centimetre); hardened in water, a second gave 90,000 pounds nearly (6,327 kilogrammes); and the third, hardened in oil, rose in tenacity to nearly 200,000 pounds per square inch (14,060 kilogrammes per square centimetre). Steel plates gained from 12 to 56 per cent., according as they were hardened at a high or low heat. This general subject of tempering steels has already been considered at length in the preceding chapter.

Careful annealing always decreases the strength of either iron or steel, while increasing its ductility. *Masses* of brittle cast iron as well as of steel may, however, be sometimes strengthened, and may often be rendered less liable to spontaneous local rupture by the process of annealing, which, in such cases, decreases or removes internal stresses such as frequently exist in large bodies, and especially in large castings. *Masses* of steel may be tempered successfully in *oil*.

Tempered steels may have their tenacity and ductility *adjusted* to any desired relation within a limited range determined by quality. When extension is small and tenacity unnecessarily great, the steel may be rehardened and tempered to bring it nearer the demanded state.

At Terrenoire, steels found to be too hard are again heated and tempered in oil at a temperature lower than at that which they were previously tempered. By this means the extension is considerably increased, without diminishing the breaking strain too much. On the other hand, when the breaking strain is too low and the extension high, the new tempering is effected at a higher temperature than the preceding one. In regular working, all the steels required to excel in resilience, if in small pieces, are heated to a yellow

color, and at that temperature are plunged into a given weight of oil in the direction of their axes. They are allowed to cool in the oil, and are reheated at a temperature varying from bright cherry red to a dull cherry color, according to the composition of the metal, and then tempered again in a bath of oil in which they are allowed to cool. The first tempering transforms the too coarsely crystalline grain of the metal into a fine homogeneous grain; the second determines the molecular equilibrium of the casting, which corresponds to the chemical composition of the metal, and should be more or less high, according as the metal contains more or less than 0.3 per cent. of carbon, and 0.5 per cent. of manganese. The chemical composition of the metal suitable for such delicate manipulation is said to be comprised between narrow limits. The carbon varies from 0.28 per cent. to 0.32 per cent.; the manganese from 0.60 per cent. to 0.45 per cent. The sulphur can scarcely be detected, and the silicon is pretty nearly constant between 0.15 per cent. and 0.20 per cent.

Hill has studied the effect of sudden and slow cooling upon various mild steels and in various ways, with the results exhibited in the following tables :

TABLE CIII.

EFFECTS OF ANNEALING STEELS.

Carbon, per cent.	Dimensions.	Average tensile resistance of 5 test pieces in lbs., per sq. in. at			Average tensile resistance of 5 test pieces in lbs., per sq. in. at			Remarks.
		Elas. lim. Rupture.		Average elongation in 12 in. per cent.	Elas. lim. Rupture.		Average elongation in 12 in. per cent.	
		Unannealed.			Annealed.			
.30	1 1/2" x 1/4" x 24" 1 1/2 inches in clear.	43,100	76,400	24	Fractures fine; and silky throughout.
		32,300	59,200	29	
.40	1 1/2" x 1/4" x 24" 1 1/2 inches in clear.	49,300	90,900	17	Fracture as above.
		41,700	79,500	22	
.50	1 1/2" x 1/4" x 24" 1 1/2 inches in clear.	56,700	97,500	13	Fracture very good.
		48,800	90,700	16	

TABLE CIII.—Continued.

COOLING AT DIFFERENT TEMPERATURES.

Carbon, per cent.	Test.	Cold.	At black heat.	At dark cherry red.	At bright cherry red.	Remarks.
Ultimate per sq. in.	74,950	70,360	62,890	57,380		
P. c. elongation in one foot.	20.	23.	28.	36.		
Reduction of area, per cent.	35.	38.	44.	53.		

ANNEALING IN LIME AND OIL.

Carbon, per cent.	Test.	Cold.	Heated to dark cherry,		Heated to bright cherry.		Remarks.
			Cooled in Lime.	Cooled in Oil.	Cooled in Lime.	Cooled in Oil.	
Ultimate per sq. in.	93,200	79,890	83,130	71,930	75,310		
P. c. elongation.	15.3	22.3	19.8	25.3	21.8		
P.c. reduction of area..	30.	38.7	40.7	42.8	46.1		

STRENGTH OF EYE-BARS. $C = 0.30$ PER CENT.

Carbon, per cent.	Mark.	Elastic limit.	Ultimate Strength.	Per cent. elongation in 45 inches.	Contraction of area, per cent.	Broke.	
		Per sq. in. of section.					
.30	A	25,780	62,790	16.0	43.8	9.75 inches from pin-hole.	Cooled from cherry red in hot ashes.
	B	28,240	63,550	15.5	45.0	8.0 inches from pin-hole.	
	C	29,770	73,130	12.5	42.6	16 $\frac{1}{2}$ inches from pin-hole.	Cooled from cherry red; once in ashes, once in oil.
	D	28,030	68,330	10.8	44.2	About middle of bar.	
	E	32,330	68,760	10.5	46.3	About middle of bar.	Cooled from cherry red in oil.
	F	33,580	67,990	12.2	45.8	About middle of bar.	
1.	43,920	70,310	22.2	33.8	Test specimens cut from original bars before working. Section 1.072 sq. in. Elongations in 10 inches.	
2.	13,980	70,690	22.8	41.4		

The first set of figures exhibit the effect of similar treat-

ment upon "steels" of different proportions of carbon. All were heated to a cherry red heat and annealed in lime, 12 hours. The effect is seen to be greatest on the softest steel.* With such steels, repeated annealing at a moderate temperature is advisable. The second set of data show that the effect of annealing is greater at high than at low temperatures. The data next given confirm Kirkaldy's conclusions relative to cooling in oil, and the effect of the oil is found to be uniformly beneficial.

All the above tests were made on small pieces. Finally, a set of eye-bars were made of "steel" containing 0.3 per cent. carbon, tempered in oil, and tested by tension. The figures above given show a decided gain in resilience by the use of oil.

The following table shows the effect of cooling bars of the same material (tool steels) † slowly or rapidly.

If the results obtained indicate more than accidental variations, the limit of elasticity was higher in the end slowly cooled, while the tensile strength was somewhat lower.

The reduced area and per cent. of elongation are compared at the maximum load, the pieces having been finally broken by different methods.

So far as this evidence can be accepted, it indicates that the end which was slowly cooled was generally more ductile than the end which cooled rapidly. This is merely, however, the usual effect of annealing as compared with rapid cooling, and these experiments are principally of value as exhibiting the magnitude of this effect, and also the extent to which the quality of iron can be modified by adjusting the rate of cooling from the red heat. As a rule, annealing is best performed in non-conductors, which may at least tend to preserve the proportion of carbon unchanged, even if they do not, like bodies rich in carbon, tend to raise it.

* *Iron Age*, March, 1883; *Mechanics*, March, 1883.

† "Report of United States Board appointed to test iron, steel, etc.," Washington, D. C., 1878.

Experiments upon the steel castings of which analyses have been already given illustrate well the importance of annealing such metals as are liable to internal stresses, thus :

TABLE CV.

EFFECT OF ANNEALING STEEL CASTINGS.

TREATMENT.	ULTIMATE STRENGTH.		ELONGATION.
	Lbs. per square inch.	Kilogrammes per square centimetre.	Per cent.
Not annealed	89,289	6,177	4
Annealed.....	104,362	7,337	8
Not annealed	71,904	5,055	4.16
Annealed.....	81,984	5,703	14.6
Not annealed	53,782	3,781	1
Annealed.....	63,616	4,572	13
Not annealed	99,496	6,995	2
Annealed.....	98,560	6,929	12
Not annealed	71,944	5,258	1.65
Annealed.....	107,744	7,574	7.2
Not annealed	67,200	4,724	13.3
Annealed.....	67,296	4,731	27.5

The Author has found, during an investigation extending from some time in 1881 to date, that annealing renders iron wire subject to a gradual yielding under permanent loads much less than those determined by ordinary test.

Phosphorus in excess of 0.08 per cent. may cause marked crystallization after long annealing.

Professor Abel concludes, after a careful investigation, that the condition of the carbon in steel determines its condition as to hardness; that in annealed steel, the carbon exists

as a definite carbide of iron, which is found in smaller proportion as steel is hardened. Professor Hughes, studying the magnetic condition of the steel, concludes it to be an *alloy* of carbon and iron, the carbide described by Abel being broken up, on hardening, to form this alloy.*

291. Effect of Age and Exposure.†—There are many phenomena which cannot be conveniently exhibited by strain diagrams; such are the molecular changes which occupy long periods of time. These phenomena, which consist in alterations of chemical constitution and molecular changes of structure, are not less important to the mechanic and the engineer than those already described. Requiring usually, a considerable period of time for their production, they rarely attract attention, and it is only when the metal is finally inspected, after accidental or intentionally produced fracture, that these effects become observable.

The first change to be referred to is that gradual and imperceptible one which, occupying months and years, and under the ordinary influence of the weather going on slowly but surely, results finally in important modification of the proportions of the chemical elements present, and in a consequent equally considerable change of the mechanical properties of the metal.

Exposure to the weather, while producing oxidation, has another important effect: It sometimes produces an actual improvement in the character of the metal.

Old tools, which have been laid aside or lost for a long time, acquire exceptional excellence of quality. Razors which have lost their keenness and their temper recover when given time and opportunity to recuperate. A spring regains its tension when allowed to rest. Farmers leave their scythes exposed to the weather, sometimes from one season to another, and find their quality improved by it. Boiler makers frequently search old boilers carefully, when reopened for repairs after a long period of service, to find any tools that

* Trans. Inst. Mechanical Engineers of G. B., 1883.

† *Journal of the Franklin Institute*, June, 1875. *Scientific American*, March 27; 1875.—R. H. Thurston.

may have been left in them when last repaired; which, if found, are almost invariably of improved quality. The Author, when a boy, amusing himself in the shop, if denied the use of their tools by the workmen, looked about the scrap-heaps and under the windows for tools purposely or carelessly dropped by the workmen; and when one was found badly rusted by long exposure, it usually proved to be the best of steel. A most striking illustration of this improvement of the quality of wrought iron with time has come to the knowledge of the Author. The first wrought-iron T-rails were designed by Robert L. Stevens, about the year 1830, and were soon afterward laid down on the Camden and Amboy Railroad. These, when put down, were considered, and actually were, brittle and poor iron. Many years later, some still remained on sidings. Some of these rails were taken up and re-rolled into bar iron. The long period of exposure had so greatly changed the character of the metal that the effect was unmistakable.

There are probably, as the Author has concluded, two methods of improvement, each due to an independent molecular action. In the case of the razor and the spring, which regain their tempers when permitted to rest, a molecular rearrangement of particles, disturbed by change of temperature in one case and by alternate flexing and relaxing in the other, probably goes on, much as the elevation of the elastic limit and the increase of resisting power, discovered by the Author and shown on the strain diagram, takes place under strain and set. The other cases may probably be due to a combination of this physical change with another purely chemical action, which is illustrated best in the manufacture of steel by the cementation process. Here the element carbon enters the solid masses of iron, and diffuses itself with greater or less uniformity throughout their volume. There seems to exist a tendency to uniform distribution which is also seen in other chemical changes. Tools having "feather-edges" afford particularly good examples of the action of time in improving the metal.

When, therefore, wrought iron containing injurious ele-

ments capable of oxidation, is exposed to the weather, the surface may be relieved by the combination of these elements with oxygen, and the surcharged interior, by this tendency to uniform diffusion, is relieved by the flow of a portion to the surface, there to be oxidized and removed. This process goes on until the metal, after lapse of years, becomes comparatively pure. Meantime, the occurrence of jarring and tremor, such as rails are subjected to, may accelerate both this and the previously described change.

292. Crystallization.—The effect of strains frequently applied, during long intervals of time, is quite different, however, where they are so great as to exceed the elastic range



FIG. 119.—FRACTURED SURFACE OF CONNECTING ROD.

of the material. The effect of stresses which strain the metal beyond the elastic limit has already been referred to.

A still more marked case has come to the notice of the writer. The great testing machine at the Washington Navy Yard has a capacity of about 300 tons, and has been in use 35 years. Quite recently, Commander Beardslee subjected it to a stress of 288,000 lbs. (130,000 kilogrammes), which stress had frequently been approached before; but it subsequently broke down under about 100 tons. The connecting bar which gave way had a diameter of five inches, and should have originally had a strength of about 400 tons (406,400 kilogrammes). Examining it after rupture, the fractured section, Fig. 119, was found to exhibit strata of varying thickness, each having a characteristic form of break. Some were quite granular in appearance, but the larger proportion were distinctly crystalline. Some of these crystals are large and well defined. The laminae, or strata, preserve their characteristic peculiarities, whether of granulation or of crystallization, lying parallel to their axis and extending from the point of original fracture to a section about a foot distant, where the bar was broken a second time (and purposely), Fig. 120, under a steam ham-

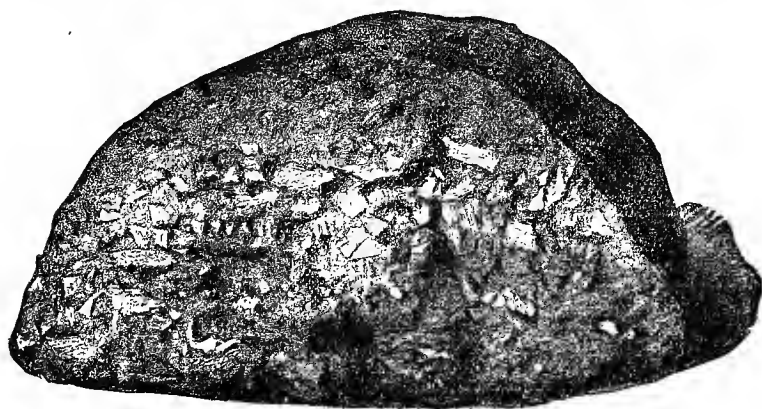

FIG. 120.—FRACTURED SURFACE OF CONNECTING ROD.

mer. It thus differs from the granular structure which distinguishes the surfaces of a fracture suddenly produced by a single shock and which is so generally confounded with real

crystallization. This remarkable specimen has been contributed by the Navy Department to the cabinet of the Author.

In a discussion which took place many years ago before the British Institution of Civil Engineers, Mr. J. E. McConnell produced a specimen of an axle which he thought furnished nearly incontestable evidence of crystallization. One portion of this axle was clearly of fibrous iron, but the other end broke off as short as glass. The axle was hammered under a steam hammer, then heated again and allowed to cool, after which it was found necessary to cut it almost half through and hammer it for a long time before it could be broken.

While forging a large shaft for a sea-going steamer at the Morgan Iron Works, in New York, some years ago, a "porter-bar" was employed which had been in the works and in frequent use for many years. This bar was about 20 feet (6.1 metres) long, 12 inches (29.5 centimetres) in diameter at the

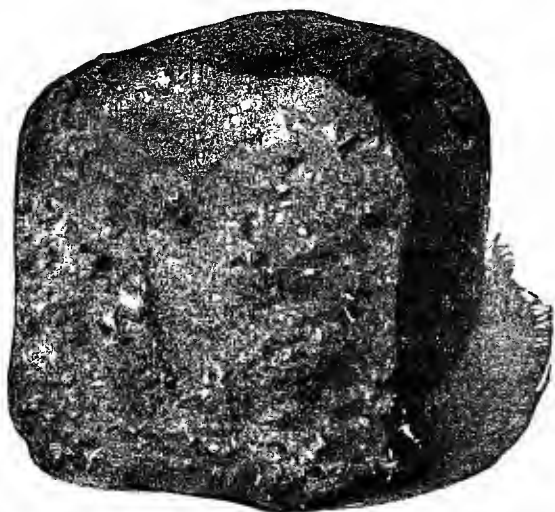

FIG. 121.—FRACTURED SURFACE OF LINK OF TESTING MACHINE.

small end, and 23 inches (58.4 centimetres) at the end welded to the forging. The whole mass was slung from the crane in

the usual way. While the shaft was under the hammer, the jar detached the end of the porter-bar on the free side of the sling, breaking it where it was about 15 inches (26.7 centimetres) in diameter, and entirely unstrained by the load, and detaching a piece weighing a ton or more. The load which would have been calculated as the breaking load hung upon the extreme end would have been about 14 tons (or tonnes). The fracture was partly granular, but largely crystalline. One crystal had faces a half inch (1.27 centimetres) square.

A student at the Stevens' Institute of Technology, while annealing a number of steel hammer heads, left them exposed all night to the high temperature of the air-furnace in the brass foundry. When finishing one of them, a careless blow broke it, and the fractured surface was found to possess a distinctly crystalline character.

In the illustration, Fig. 122 is a magnified representation of the surface of fracture. The two holes shown, penetrating the mass, are those

drilled in the first operation, preparatory to fitting the handle. The facets of the crystals are seen to be remarkably perfect and well defined. Fig. 123 represents the hammer on very nearly the natural scale. In this example, however, the faces were nearly all pentagonal, and were usually very perfectly formed. When imperfect crystals are developed, it is easy to mistake them, but the formation of pentagonal dodecahedra, in large numbers and in perfectly accurate forms, may

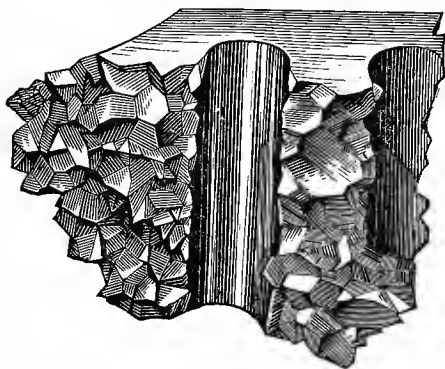

FIG. 122.—HAMMER-HEAD, MAGNIFIED.

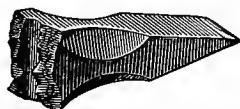

FIG. 123.—HAMMER-HEAD, NATURAL SIZE.

be formed in large numbers and in perfectly accurate forms, may

be considered unmistakable evidence of the fact that iron may crystallize in the cubic, or a modified system. This may apparently take place, according to some authorities, either by very long continued jarring of the particles beyond their elastic limits, or under the action of high temperature, by either mechanical or physical tremor. But no evidence is given here that a single suddenly applied force, producing fracture, may cause such a systematic and complete rearrangement of molecules. The granular fracture produced by sudden breaking, and the crystalline structure produced as above during long periods of time, are, apparently, as distinct in nature as they are in their causes.

But simple tremor, *where no sets of particles are separated so far as to exceed the elastic range*, and to pass beyond the limit of elasticity, does not seem to produce this effect.

In fact, some of the most striking illustrations of the improvement in the quality of wrought iron with time have occurred where severe jarring and tremor were common. As one example, the case of the wrought-iron T-rails, laid down on the Camden and Amboy Railroad in 1832, which have been already referred to, may be taken.

Here the metal has been subjected for many years to the strains and tremor accompanying the passage of trains without apparent tendency to crystallization, and with evident improvement in its quality.

Such crystallization as that last described has often been observed. Wöhler found cubic crystals in cast-iron plates which had been for some time kept at nearly the temperature of fusion in a furnace, and Augustine found similar crystals in gun-barrels; Percy found octahedra of considerable size in a bar which had been used in the melting pot of a glass furnace. Fairbairn asserts the occasional occurrence of such change due to shock, jar, and long-continued vibration. Miller found cubic crystallization plainly exhibited in Bessemer iron, which may, however, have been due to the presence of manganese. Hill shows* that heat may produce such

* *Iron Age*, 1882; *Mechanics*, 1882.

changes in the process of manufacturing large forgings, and denies the occurrence of true crystallization in cold iron. This can only be settled by further investigation.

Dr. Sorby has examined the structure of wrought iron and of steel with the microscope, and found the hammered bloom to be a mixture of crystals of iron and portions of slag. The rolled bar, Fig. 126, contained crystals also, but they were fresh crystals formed on the cooling of the bar, and it was apparent that the fibre seen at the fracture was produced during rupture, and was not a characteristic of the unaltered iron. The cementing process of steel making was found to develop a network of flat crystals of a hard carbide of iron. Cast steel, Fig. 125, was found to contain larger crystals, of a different form, which were reduced in size by subsequent working. Meteoric iron, Fig. 124, was found to exhibit the characteristics of an iron crystallized by long exposure to a temperature beneath that of fusion.

Dr. Sorby's paper has been published with illustrations, which are reproduced in the accompanying engravings.* The samples in question comprised armor plates, meteoric iron, cast iron and cast steel, and, as an inspection will show, exhibit a greatly varying structure. The specimen of cast steel is of very uniform structure, with no lines of weakness, while an inspection of the specimen of cast iron will reveal a number of plates of graphite, that naturally tend to diminish the strength of the metal. The armor plate, on the other hand, shows varying crystals and lines of welding, while the sample of meteoric iron shows a structure altogether unlike that of any artificial iron.

Martens has used the microscope in the examination of various grades of iron and of spiegeleisen,† with somewhat inconclusive results. But he finds that certain peculiarities and characteristics, due especially to the various mechanical operations which the material undergoes, either during the process of manufacture, or molecular changes to the manner in

* J. C. Bayles, in *Iron Age and Mechanics*, Mch., 1883; *Trans. Am. Inst. M. E.*, 1880.

† Verein zur Beförderung des Gewerbflusses, 1882.

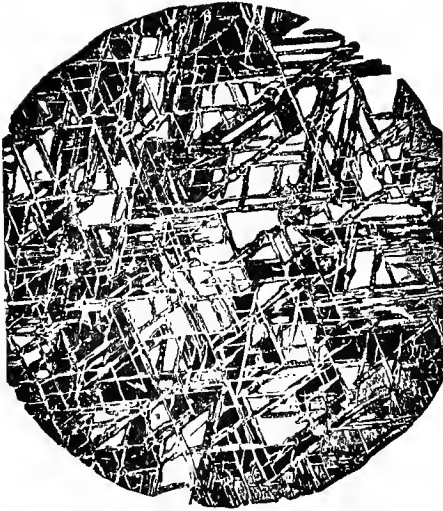

FIG. 124.—METEORIC IRON.

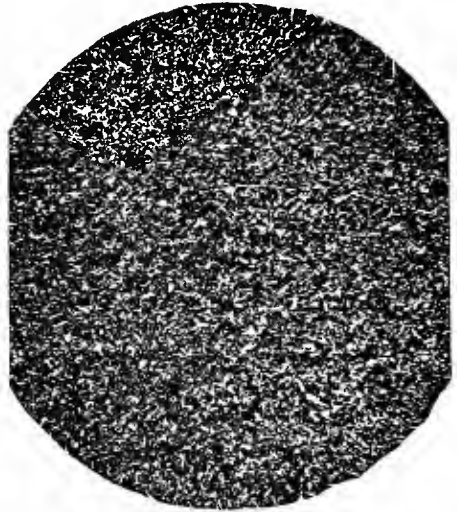

FIG. 125.—CAST STEEL.



FIG. 126.—ARMOR PLATE.

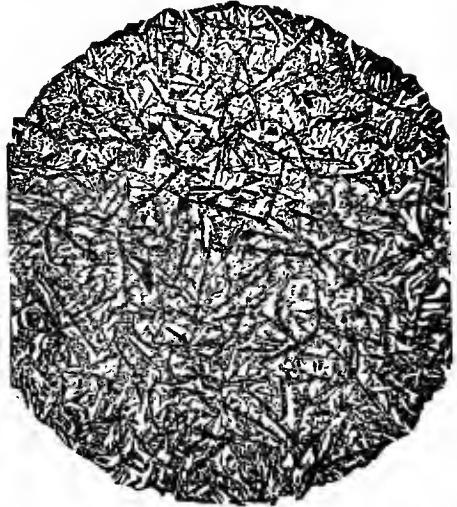

FIG. 127.—CAST IRON.

which it is strained in performing its functions as part of a structure, can probably thus be best and most satisfactorily investigated. An examination of a specimen of gray pig iron showed that the sharp veins of graphite seldom touched the surface of the white iron. In a specimen of spiegeleisen the individual figures have a definite shape, often resembling small fir trees, which end in lines, and finally in points. Similar observations have also been made in connection with soft gray pig iron, which is distributed through the spiegeleisen. The dark portions correspond to gray pig iron, Fig. 127, while the light portions represent the spiegel.

These phenomena are undoubtedly closely connected with the crystallization of iron. The crystals of graphite consist of a series of hexagonal scales, and the flakes, as a rule, occur in a developed state only in gray pig iron, being either entirely absent in spiegeleisen, or only of rare occurrence. As shown by microscopical examinations, crystals of iron are not perfectly pure, although it has been stated that crystals having the shape which Martens calls "fir-tree crystals," actually consist of pure iron. Crystals of both gray and white iron occur together, especially in iron which contains a large proportion of manganese. Martens finds that the fractured surfaces of bars which are broken under repeated use exhibit distinctive features.

Surfaces to be examined by the microscope should be first very carefully planed up and smoothly polished; they should next be well washed with a dilute alkaline solution, to remove all greasy matter, and finally "etched" with dilute acid sufficiently to exhibit well the structure of the metal. The latter process is best practised with very dilute nitric or hydrochloric acid, exposing the surface to its action a few minutes at a time, washing with water and repeating the operation until the surface is brought into the condition in which the microscope is found to best exhibit its characteristics.

293. The Flow of Metals.—M. Tresca, published in *La Poinçonnage des Métaux*, some experiments on the punching of iron, using a large diameter of punch upon small thickness

of metal. His experiments were made with a punch of 1.18 inches diameter (3 centimetres) on iron plates, the greatest thickness being 0.669 inch (1.8 centimetres), and the least 0.1968 inch (0.5 centimetre). He announced, as the result of his investigations, the general law that "when pressure is exerted upon the surface of any material, it is transmitted in the interior of the mass from particle to particle, and tends to produce a flow of metal in the direction in which the resistance is least."

Experiments made with nuts or bars punched cold show that an actual flow does take place in metals under pressure, which flow is governed by some law not yet enunciated.*

As the punch entered, a flow took place, which was greatest in the width—the direction of least resistance—the length being but slightly increased; the increase was greatest on the bottom face of the block. The metal at the top was therefore compelled to spread laterally, producing increased width.

The punched block was bulged in the width, producing a curved surface, concave toward the axis, greatest at the central line of its width, and decreasing gradually in either direction as it departs from that line.

The length is also increased, but not as noticeably as the width.



FIG. 128.

Fig. 128 represents, full size, the core punched from the block, Fig. 129; it is only $\frac{1}{8}$ inches in depth, while the hole from which it came was $1\frac{3}{4}$ inches deep. At first sight, it would seem that all the metal from the hole had been squeezed into the core, and, therefore, that its density must be increased. But the density of the block was 7.82. The core itself had a density of 7.78.

The density of the block is slightly more than that of the core; but this difference is probably due to the density of the surface being increased by chipping and filing, and also to the greater soundness of the block. As the density has not increased, there must have been a flow of metal from the core into the block.

* *Journal of the Franklin Institute*, March, 1878. D. Townsend.

These experiments were tried with other thicknesses ; the flow seemed to decrease directly as the diameter of the hole increased, and as the thickness of the bar decreased.

In order to show to the eye the flow which had thus occurred, several of the large nuts with their cores were planed in half. The resulting rectangular faces being brightly polished and perfectly clean, were then etched with acids of various strengths, when they presented the appearances of



FIG. 130.

FIGS. 129 and 130. The curved lines mark the laminæ, or plates, which were piled and rolled together to make up the bar. It will be

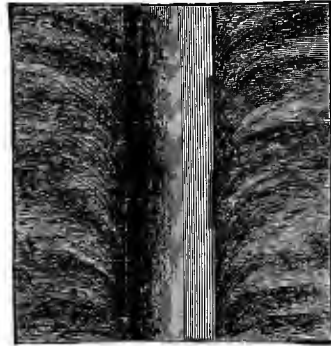

FIG. 129.

noticed that they all curve downward, and that the greatest curvature occurs at the top, remaining nearly constant for some distance, and then decreasing toward the bottom. The flow must have occurred when the punch first entered the bar, and continued regularly, until the pressure above parted the under face, and the core was forced out.

In the case represented in Figs. 131 and 132, the hole was punched *with* the grain, instead of *across* it, the result being that the superposed laminæ,

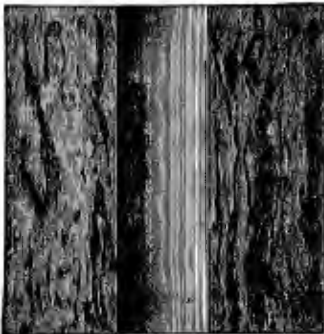

FIG. 131.

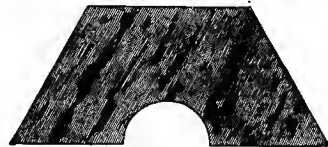

FIG. 132.

instead of being curved downward, were wrinkled or warped, from the flow and the conse-

quent pressure which took place, acting against their sides or faces.

Several experiments were tried by partially punching bars of the same thickness with punches that had the same diameter, but which varied in length according to the depth of the hole to be punched. The bars were uniformly $1\frac{3}{8}$ inches thick, and the punch $\frac{7}{8}$ inch in diameter.

In the last experiment the punch was stopped at a depth of $1\frac{1}{2}$ inches, the resulting block being shown in Fig. 134. The core projects from the bottom face nearly $\frac{1}{2}$ inch,

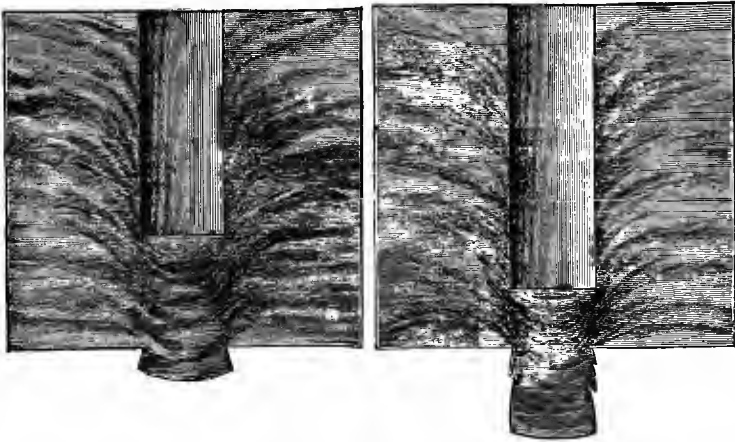

FIG. 133. PUNCHED NUTS ; FULL SIZE. FIG. 134.

and measures, as before, almost $\frac{3}{4}$ inch in depth. The layers, in this case, are all severed, and the line of parting of the core from the block is plainly visible. The process of punching these thick bars does not depend for its successful performance upon the time taken, but upon the accuracy and power of the machine, and the quality of the punch.

For account of Mechanical Processes, see Part 3, Chapter XIV.

294. Relief of Internal Stresses by Rest.—A method of *improvement* under such conditions as have been elsewhere described, and one which seems likely to have an effect of especial importance in castings in hardened and in tempered metals, is the gradual relief, by rest, of those internal

stresses which are induced by working malleable iron, by casting cast irons, and by tempering steel. These stresses are apparently relieved by the process of flow investigated by Prof. Henry and Mon. Tresca.

Rodman reports* the following tests of cannon tested in one case, a few days after they were cast, and in another case, more than six years later :

	S. G.	TENACITY.	ENDURANCE.
Cast in 1851 and proved same year.....	7.287	{ 37,811 } 2,658 }	72 fires.
Cast in 1846 and proved in 1852.....	7.247	{ 29,423 } 2,068 }	2,582 "
" " " " " " "	7.220	{ 22,989 } 1,616 }	800 "

Tenacities are given in pounds per square inch, and in kilogrammes per square centimetre. Rodman calls attention to this extraordinary difference, and explains the change in the manner already indicated, illustrating it by reference to the readiness with which pieces of metal under strain conform to the new shape given them, as when hoops bent upon barrels at first lose but little of their power of restoration, but afterward take permanently the bend given them; this process being repeated, they may finally take a bend that would at first have broken them. In the case above cited, the metal of highest tenacity proved weakest under fire. Hard and strong cast iron is most liable to internal stress.

The Author tested wires from the cables of the Fairmount Suspension Bridge, at Philadelphia, when taken down after 32 years' use, and found them fully equal in tenacity and ductility to wire of similar grade just from the wire mill. This tenacity was about 90,000 pounds per square inch (6,327 kilogrammes per square centimetre); they were 0.1236 inch (0.314 centimetre) in diameter.

Iron and steel wire is found stronger and more ductile after having been kept long in stock, than if tested when first

* Report on Metals for Cannon, p. 217.

made. It is, therefore, advisable to keep all strained metals out of use as long as is possible or convenient before subjecting them to stress.

295. The Effect of Time under Stress is also often observable, and is frequently even important. It is not the same for all metals, or even for different specimens of the same class.

M. Vicat states that in his experiments* four wires were loaded, respectively, with $\frac{1}{4}$, $\frac{1}{3}$, $\frac{1}{2}$ and $\frac{3}{4}$ their ultimate resistance, and their elongations were observed and recorded at intervals of one year.

The relative extensions observed indicated a gradual lengthening of the three which were strained beyond the elastic limit, and that most strained finally broke, after sustaining three-fourths its original ultimate breaking weight two years and nine months, the point of rupture being finally determined by the action of corrosion, which had not been entirely prevented.

The several extensions were as follows :

No. 1, sustaining $\frac{1}{4}$, 33 months.....	0.000 per cent.
No. 2, sustaining $\frac{1}{3}$, 33 months.....	0.275 per cent.
No. 3, sustaining $\frac{1}{2}$, 33 months.....	0.409 per cent.
No. 4, sustaining $\frac{3}{4}$, 33 months.....	0.613 per cent.

The rate of extension was nearly proportional to the times, and the total extension to the forces. M. Vicat concludes that metal thus overstrained will ultimately break, and his paper has been supposed to indicate a possibility of the ultimate failure of structures having originally an ample factor of safety.

Fairbairn made experiments of nearly the same nature as those of Vicat, upon cast-iron bars loaded transversely. These bars were $4\frac{1}{2}$ feet (1.4 metres) between supports, and loaded with two-thirds their breaking weights. Cold-blast iron increased in deflection from 1.27 inches (3.23 centimetres) to 1.31 inches (3.33 centimetres) in five years; the hot-blast bars

* *Annales de Chimie et de Physique*, 1834. Tome 54, p. 35.

deflected 1.46 inches (3.7 centimetres) to 1.62 inches (4.1 centimetres) in the same time. The deflection *decreased* after 1¼ years, and increased again during the last two.

The Author has similarly investigated the action of prolonged stress, using wire of Swedish iron; but one set of samples was annealed; the other, of two sets, was left hard, as drawn from the wire blocks. The size selected was No. 36, 0.004 inch (0.01 millimetre) diameter, and were loaded with 95, 90, 85, 80, 75, 70, 65 and 60 per cent. of the breaking load as obtained by the usual method of test. The result was (the strength of the hard was double that of the soft wire):

TABLE CVI.

ENDURANCE OF IRON WIRE UNDER STATIC LOAD.

PER CENT. MAX. STATIC LOAD.	TIME UNDER LOAD BEFORE FRACTURE.	
	Hard wire (unannealed).	Soft wire (annealed).
95	8 days.	3 minutes.
90	35 days.	5 minutes.
85	Unbroken at end of 16 mos.	1 day.
80	91 days.	266 days.
75	} Unbroken.	17 days.
70		455 days.
65		455 days.
	Several remain unbroken (1898) after 13 years.	All broken (1890).

This very remarkable difference between hard drawn and annealed iron, thus discovered by the Author, throws some light upon the discrepancy previously supposed to exist between the results of Vicat's experiments and common experience, as well as upon the conditions of safety of loaded iron structures. Soft irons and the "tin class" of metals and the woods are thus found to demand a higher factor of safety than hard iron. The elegant and valuable researches, also, of Mons. H. Tresca on the flow of solids,* and the illustrations of this action almost daily noticed by every engineer, seem to lend

* *Sur l'Écoulement des corps solides.* Paris, 1869-72.

confirmation to the supposition of Vicat. The experimental researches of Prof. Joseph Henry, on the viscosity of materials, and which proved the possibility of the co-existence of strong cohesive forces with great fluidity,* long ago proved also the possibility of a behavior in solids, under the action of great force, analogous to that noted in more fluid substances.

On the other hand, the researches of the writer, indicating by strain diagrams that the progress of this flow is often accompanied by increasing resistance, and the corroboratory evidence furnished by all such carefully made experiments on tensile resistance as those of King and Rodman, Kirkaldy and Styffe, have made it appear extremely doubtful whether hard iron is ever weakened by a continuance of any stress not originally capable of producing incipient rupture.

296. Velocity of Rupture ; Shock.—Kirkaldy concludes that the additional time occupied in testing certain specimens of which he determined the elongation "had no injurious effect in lessening the amount of breaking strain."† An examination of his tables shows those bars which were longest under strain to have had highest average resistance.

Wertheim supposed that greater resistance was offered to rapidly than to slowly produced rupture.

The experiments of the Author prove that, as had already been indicated by Kirkaldy, a lower resistance is offered by ordinary irons as the stress is more rapidly applied. This effect conspires with *vis viva* to produce rupture.

We conclude that the rapidity of action in cases of shock, and where materials sustain live loads, is a very important element in the determination of their resisting power, not only for the reason given already, but because the more rapidly common iron is ruptured the less is its resistance to fracture. This loss of resistance is about 15 per cent.‡ in some cases, noted by the Author, of moderately rapid distortion.

* *Proc. Am. Phil. Society*, 1844.

† *Experiments on Wrought Iron and Steel*, pp. 62, 83.

‡ Compare Kirkaldy, p. 83, where experiments which are possibly affected by the action of *vis viva* indicate a very similar effect.

The cause of this action bears a close relation to that operating to produce the opposite phenomenon of the elevation of the elastic limit by prolonged stress, to be described, and it may probably be simply another illustration of the effect of internal strain. Metals of the "tin class" exhibit, as has been shown by the Author,* an opposite effect. Rapidly broken they offer greater resistance than to a static or slowly applied load. It has also been seen that annealed iron has, in some respects, similar qualities.

With a very slow distortion the "flow" already described occurs, and but a small amount of internal strain is produced, since, by the action noticed when left at rest, this strain relieves itself as rapidly as produced. A more rapid distortion produces internal stress more rapidly than relief can take place, and the more quickly it occurs the less thoroughly can it be relieved, and the more is the total resistance of the piece reduced. Evidence confirmatory of this explanation is found in the fact that bodies most homogeneous as to strain exhibit these effects least.

It does not now seem remarkable that, at extremely high velocities, the most ductile substances exhibit similar behavior when fractured by shock or by a suddenly applied force, to substances which are really comparatively brittle.* In the production of this effect, which has been frequently observed in the fracture of iron, although the cause has not been recognized, the inertia of the mass attacked and the actual depreciation of resisting power just observed, conspire to produce results which would seem quite inexplicable, except for the evidently great concentration of energy here referred to, which, in consequence of this conspiring of inertia and resistance, brings the total effort upon a comparatively limited portion of the material, producing the short fracture, with its granular surfaces, which is the well-known characteristic of

* *Trans. Am. Soc. C. E.*, 1874, *et seq.*

† Specimens from wrought-iron targets shattered by shock of heavy ordnance, in the possession of the Author, exhibit this change in a very unmistakable manner.

sudden rupture. Any cause acting to produce increased density, as reduction of temperature, evidently must intensify this action of suddenly applied stress.

The liability of machinery and structures to injury by shock is thus greatly increased, and it is quite uncertain what is the proper factor of safety to adopt in cases in which the shocks are very suddenly produced.

Meantime the precautions to be taken by the engineer are: To prevent the occurrence of shock as far as possible, and to use in endangered parts light and elastic members, composed of the most ductile materials available, giving them such forms and combinations as shall distribute the distortion as uniformly and as widely as possible.

The behavior of materials subjected to sudden strain is thus seen to be so considerably modified by both internal and external conditions which are themselves variable in character, that it may still prove quite difficult to obtain mathematical expressions for the laws governing them. An approximation, of sufficient accuracy for some cases which frequently arise in practice, may be obtained for the safety factor by a study and comparison of experimental results.

297. "Rate of Set" of Metals Subject to Stress for Considerable Periods of Time.—The results of experiments made by the Author to determine the time required to produce "set" in metals loaded more or less heavily, and to ascertain what law governs the influence of time in determining the progress and the limit of change of form as the metal yields under loads, either very small or approaching the ultimate strength of the piece, were reported to the American Society of Civil Engineers, January, 1877.*

Two methods of testing bars by transverse stress were adopted. By the first method, the bar was bent to a certain carefully measured deflection, and there held, and its effort to straighten itself was as carefully measured. This effort was at first equal to the load required to bend the bar to the observed deflection, but it gradually became less and less as

* Trans. Am. Society of Civil Engineers, 1877. *Iron Age*, 1877.

the bar took a set, and finally either became constant, or the bar broke. In the first case, this loss of straightening power ceased when the bar had taken its set completely.

By the second method, the bar was similarly mounted between supports, but was then loaded with a "dead load" of a certain carefully measured amount, and the manner in which deflection took place and its amount, were very accurately observed. When the deflection no longer increased, and the bar remained at a constant deflection, the set was complete. In some cases the increase of deflection did not cease until the bar broke.

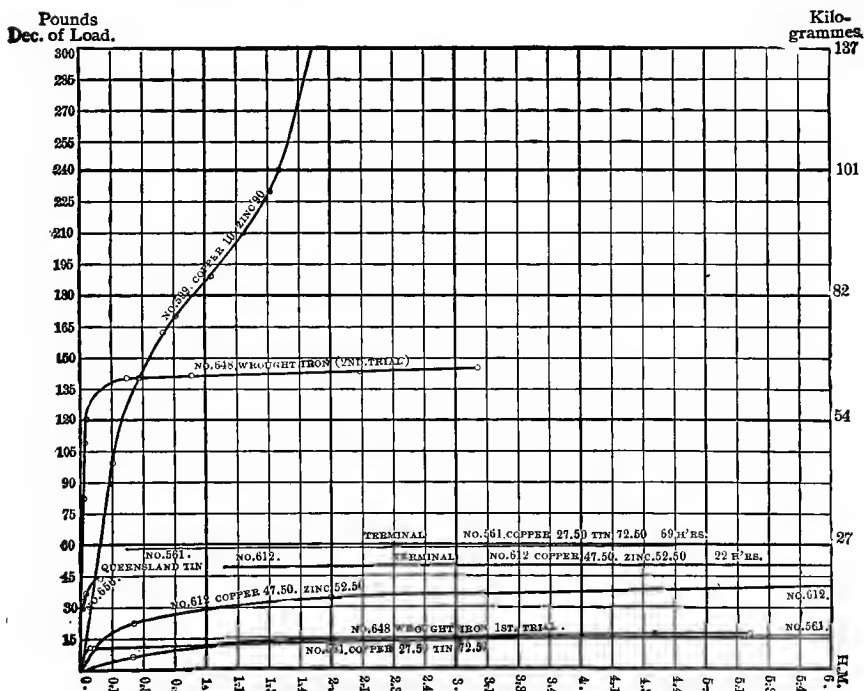

FIG. 135.—DECREASE OF RESISTANCE WITH TIME.

This research was thus divided into two parts: The first on the observed decrease of resistance at a fixed distortion; the

second on the observed increase of deflection under static loads. We here present the principal deductions.

Bars were prepared of square section, 1 inch (2.54 centimetres) in breadth and depth, and 22 inches (56 centimetres) in length between bearings. They were flexed in a machine for testing the resistance of materials to transverse stress, and the load and deflection carefully measured. As the bars were retained at a constant deflection, their effort to resume their original form gradually decreased, and the amount of this effort was from time to time noted. When this effort or resistance had become considerably decreased, the bar was released and the set measured. This operation was repeated with each until the law of decrease of elastic resistance was detected. Curves (Fig. 135) were constructed, illustrating graphically this law.

In all of these metals the set and the loss of effort to resume the original form were phenomena requiring time for their progress, and in all, except in the case of No. 599—which was loaded heavily—the change gradually became less and less rapid, tending constantly toward a maximum.

So far as the observation of the Author has extended, the latter is always the case under light loads. As heavier loads are added, and the maximum resistance of the material is approached, the change continues to progress longer, and, as in the case of the brass above described, it may progress so far as to produce rupture, when the load becomes heavy, if the metal does not belong to the "iron class." The brass broke under a stress 25 per cent. less than it had sustained previously.

Other experiments were conducted with the same object as those above described. In these experiments, however, the load, instead of the distortion, was made constant, and deflection was allowed to progress, its rate being observed, until the test piece either broke under the load or rapidly yielded, or until a permanent set was produced. The results of these experiments are in striking accordance with those conducted in the manner previously described; they exhibit the fact of a gradually changing rate of set for the several cases of light or heavy loads, and illustrate the distinctions between

the two classes of metals even more plainly than the preceding. The record and the strain diagrams (Fig. 136), which are its graphical representation, exhibit the method of research and its results.

Inches of Deflection.

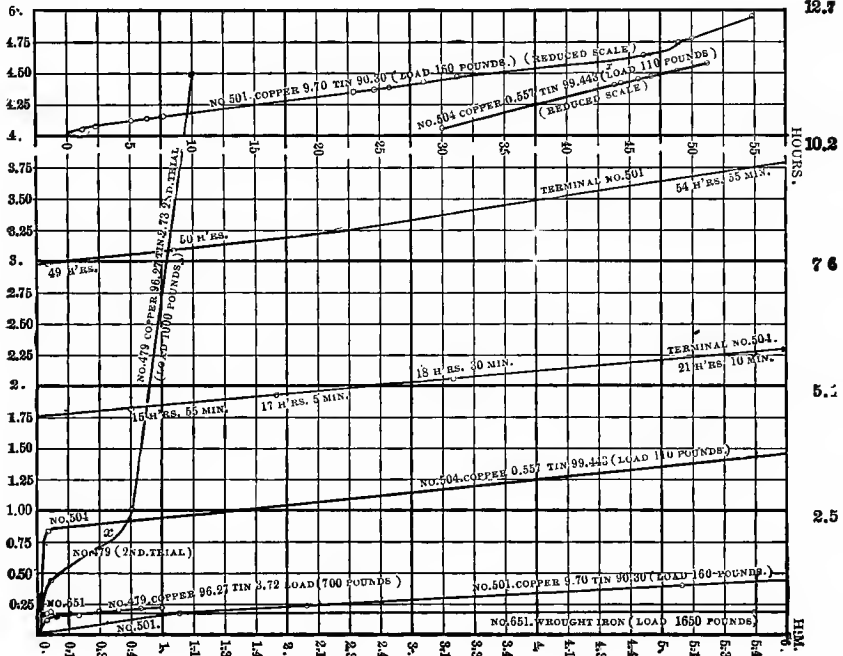

FIG. 136.—INCREASE OF DEFLECTION WITH TIME.

The test of No. 501 extended over nearly $2\frac{1}{2}$ days under observation, and then left for the night, was found next morning broken. The time of fracture is therefore unknown, as is the ultimate deflection. The record is, however, sufficient to determine the law, and the strain diagram (Fig. 136) is seen to be similar to that of the second test of No. 479, exhibiting the same tendency to the parabolic shape and the same change of law and reversal of curvature preceding final rupture; and it illustrates even more strikingly the fact that this class of metals is not safe against final rupture, even

though the load may have been borne a considerable time, and they have apparently been shown by actual test to be capable of sustaining it.

In further illustration of the peculiar characteristics of

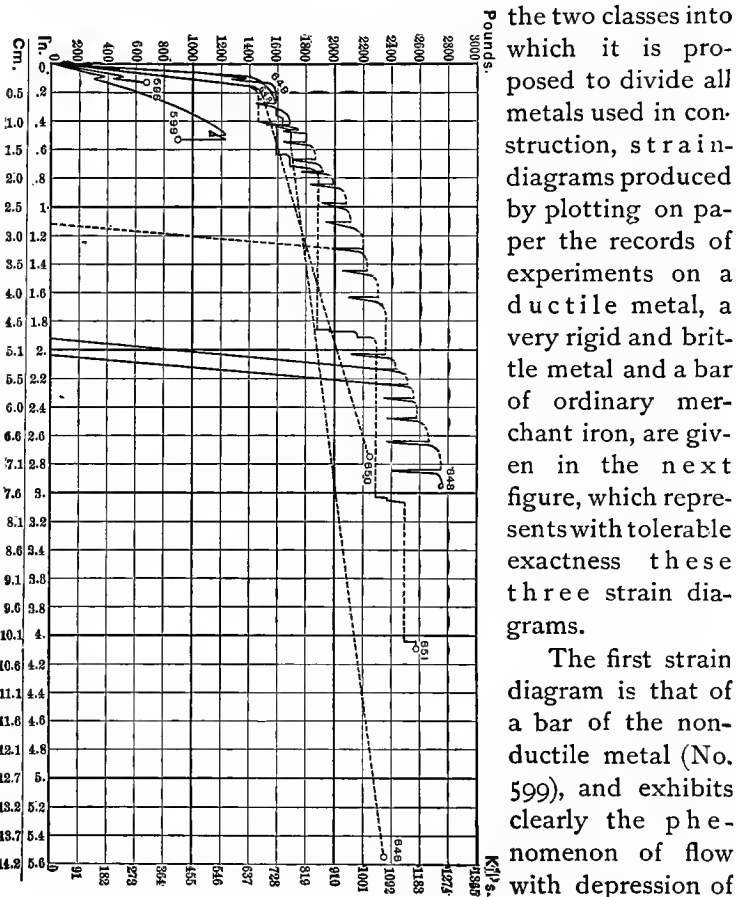

FIG. 137.—EXALTATION OF ELASTIC LIMITS.

during rest. The horizontal scale is proportional to deflections and the vertical to deflecting forces.

This bar was left under each load until deflection no longer increased before adding to the load.

Before the bar, under further deflection, had quite re-

the two classes into which it is proposed to divide all metals used in construction, strain-diagrams produced by plotting on paper the records of experiments on a ductile metal, a very rigid and brittle metal and a bar of ordinary merchant iron, are given in the next figure, which represents with tolerable exactness these three strain diagrams.

The first strain diagram is that of a bar of the non-ductile metal (No. 599), and exhibits clearly the phenomenon of flow with depression of the elastic limit

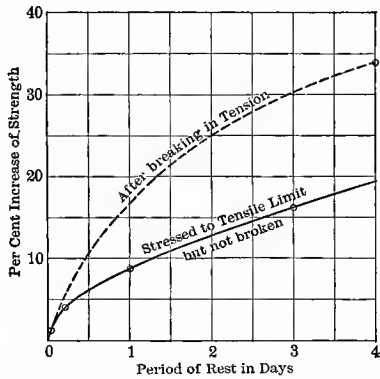
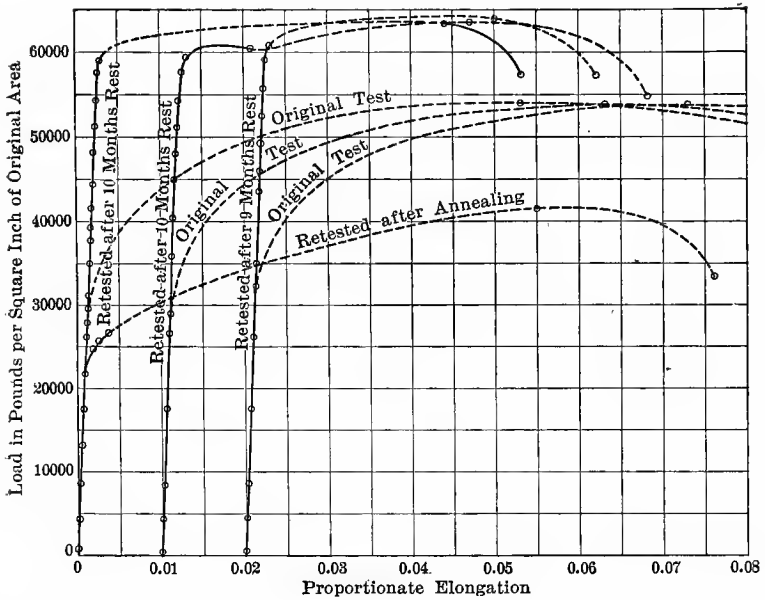

FIG. 137a.—EXALTATION OF ELASTIC LIMIT
Wrought Iron—Successive Tests. U. S. Repts., 1881-82

gained its original resisting power, a "time-test" was made, the deflection amounting to 0.5456 inch, and the weight applied being 1,233 pounds. The result noted was singular. The effort steadily decreased at a varying rate, which is indicated by the diagram of time and loads, and the bar finally snapped sharply, and the two halves fell upon the floor. The effort had decreased to 911 pounds. The deflection was precisely what it had been under the load of 1,233 pounds. The beam had balanced at 911 pounds for about three minutes when the fracture took place.

The bar was hard, brittle, and elastic, but must apparently be classed with tin in its behavior under either continued or intermitted stress.

There seems to the Author to exist a distinction, illustrated in these cases, between that "flow" which is seen in these metals, and that to which has been attributed the relief of internal stress and the elevation of the elastic limit by strain and with time.

This last phenomenon—the exaltation of the elastic limit by strain—has been observed very strikingly, by the writer, in the deflection of iron bars by transverse stress. The plate exhibits also the strain diagrams obtained by transverse deflection of four bars of ordinary merchant wrought iron, which were all cut from the same rod. Of these, two were tested in the Fairbanks machine, in which the deflection remains constant when the machine is untouched, while the load gradually decreases—or, more properly, while the effort of the bar to regain its original form, decreases. The other two were tested by dead loads—the load remaining constant, while the deflection may vary when the apparatus is left to itself.

These two pairs of specimens were broken; one in each set by adding weight steadily until the end of the test, so as to give as little time for elevation of elastic limits as was possible, and one in each set by intermittent stress, observing sets, and the elevation of the elastic limit of metals. As seen by study of these diagrams, both classes, when strained by flexure, gradually exhibit less and less effort to restore themselves to their original form.

In the case of the tin class, this loss of straightening power seems often to continue indefinitely, and, as in one example here illustrated, even until fracture occurs.

With iron and the class of which that metal is typical, this reduction of effort becomes gradually less and less rapid, and finally reaches a limit after attaining which the bar is found to have become strengthened, and the elastic limit to have become elevated. In this respect the two classes are affected by time of stress in precisely opposite ways.

The plate exhibits superior ultimate resistance of bars which have been intermittently strained, as well as elevation of the elastic limit. The parallelism of the "elasticity lines" obtained in taking sets, shows that the modulus of elasticity is unaffected by the causes of elevation of the elastic limit.

Evidence appealing directly to the senses has been presented in the course of experiment on the second class of metals, of intra-molecular flow. When a bar of tin is bent, it emits while bending the peculiar crackling sound, familiarly known as the "cry of tin." This sound has not been observed hitherto, so far as the Author is aware, when a bar has been held flexed and perfectly still. In several cases in experiments on flexure of metals of the second class, bars held at a constant deflection have emitted such sounds hour after hour, while taking set and losing their power of restoration of shape.*

298. The Variation of the Normal Elastic Limits with Time.—The elevation of the normal series of elastic limits, and of strength, by intermitting strain was discovered by the Author and by Captain Beardslee, of the U. S. Navy, independently, in the year 1873. It is variable in amount with different materials of the iron class, and the rate at which this exaltation progresses is also variable. With the same material and under the same conditions of manufacture and of subsequent treatment, the rate of exaltation is quite definite, and may be expressed by a very simple formula. The process of exaltation of the normal elastic limit due to any given degree of strain usually nearly approaches a maxi-

* *Trans. Am. Soc. C. E.*, 1876.

imum in the course of a few days of rest after strain, its progress being rapid at first and the rate of increase quickly diminishing with time. For some good bridge or machinery irons, the amount of the excess of the exalted limit, as shown by subsequent test, above the stress at which the load had been previously removed may be expressed approximately by the formula :

$$E' = 5 \log T + 1.50 \text{ per cent. ;}$$

in which the time, T , is given in hours of rest after removal of the tensile stress which produced the noted stretch.

Captain Beardslee found that, with good ductile iron, the ultimate strength is increased over 15 per cent. by being strained nearly to its limit of tenacity and then allowed to rest for at least one day. With coarse brittle iron, the increase of strength is not so great, a number of specimens of this character showing an average gain of about 6 per cent. Another set of experiments upon the action of this law was made by breaking a bar in its normal condition, and again, several days afterward, breaking one of the pieces. The second piece invariably showed a very much greater strength than the first, the gain in some cases being 20,000 pounds per square inch, or nearly 40 per cent.

This peculiar effect is well shown by a pair of bars exhibited in Fig. 138.

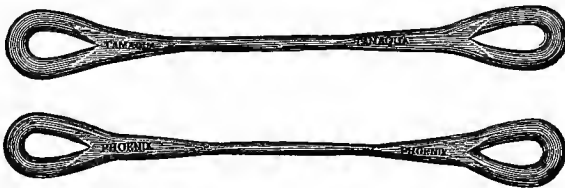

FIG. 138.—EFFECT OF INTERMITTED STRAIN.

The upper specimen broke in the eye while under test and after it had begun to draw down, as seen near the letter T in the name at the right. When repaired and again tested next day, it broke in a new place nearer the middle, and under 30

TABLE CVII.—ELEVATION OF THE MAXIMUM LIMIT OF STRESS.

NUMBER OF TEST.	SIZE OF BAR.	STRENGTH IN POUNDS PER SQUARE INCH.		INTERVAL BETWEEN TESTS.	GAIN IN STRENGTH.	RATIO OF CHANGES OF FORM AT TENSILE LIMIT TO THAT AT FRACTURE.		SPEED AT WHICH RUPTURE WAS EFFECTED.
		1st Test.	2d Test.			Reduction of area.	Elongation.	
13	I 1/4	50,825	51,351	1 minute ..	<i>Per cent.</i> 1	<i>Per cent.</i> 51	<i>Per cent.</i> 71	F.
14	I 1/4	48,809	49,110	1 minute ..	0.6	44	78	S.
15	I 1/4	49,877	50,614	3 minutes .	1.5	50	73	M.
16	I 1/4	49,024	49,637	3 minutes .	1.3	46	67	F.
17	I 1/4	49,865	50,388	3 minutes .	1.0	51	79	S.
18	I 1/4	49,345	49,993	1 hour	1.3	56	80	S.
19	I 1/4	49,358	50,219	2 hours....	1.7	56	85	S.
20	I 1/4	49,459	51,362	3 hours....	3.8	S.
21	I 1/4	49,484	51,546	4 hours....	4.2	S.
22	I 1/4	49,401	51,561	5 hours....	4.3	50	85	S.
23	I 1/4	49,206	51,906	6 hours....	5.6	56	83	S.
24	I 1/4	50,257	52,886	7 hours....	5	52	82	S.
25	I 1/4	50,013	52,572	8 hours....	5	54	80	S.
26	I 1/4	51,536	60,651	3 days	17.6	53	74	S.
27	I 1/4	49,935	58,251	3 days	17	58	80	S.
28	I 1/4	49,962	56,207	3 days	12.5	49	85	S.
29	I 1/4	49,175	57,635	3 days	17.2	56	76	S.
30	I 1/4	49,207	58,049	3 days	17.8	52	75	F.
31	I 1/4	50,143	58,136	3 days	14.1	54	80	S.
32	I 1/4	49,266	57,263	3 days	16.2	50	77	S.
33	I 1/4	49,438	57,991	3 days	17.3	51	79	S.
34	I 1/4	48,537	54,655	3 days	12.6	50	67	F.
35	I 1/4	48,597	57,124	3 days	17.5	61	85	M.
36	I 1/4	48,853	57,443	8 days	17.6	53	76	M.
37	I 1/4	50,015	59,047	8 days	18	51	83	M.
38	I 1/4	50,474	59,864	18 days	18.6	65	83	S.
39	I 1/4	50,178	58,314	18 days	16.1	66	88	S.
40	I 1/4	50,165	54,749	18 days	9	57	94	F.
41	I 1/4	49,676	59,184	25 days	19.1	56	79	M.
42	I 1/4	49,867	55,949	42 days	12.2	54	93	F.
43	I 1/4	51,128	60,902	6 months ..	19.1	57	84	S.
44	I 1/4	50,530	59,626	6 months ..	18	51	80	S.
45	I 1/4	49,101	57,877	6 months ..	17.8	52	79	M.
46	I 1/4	48,810	56,885	6 months ..	16.6	55	79	S.
47	I 1/4	51,838	57,188	6 months ..	10.3	47	75	S.
48	I 1/4	49,144	58,188	6 months ..	18.3	52	78	S.
49	I 1/4	48,792	57,403	6 months ..	17.2	49	95	F.
50	I 1/4	49,370	58,880	6 months ..	19.4	52	78	S.
51	2 1/2	49,250	58,020	6 months ..	17.7	53	76	S.
52	2 1/2	47,871	58,976	6 months ..	22.6	53	83	S.
53	2 1/2	46,702	54,458	6 months ..	16.6	51	78	S.
54	3	47,655	57,250	6 months ..	20	42	60	S.

ABSTRACT FROM DETAIL OF TESTS.

Average gain in less than 1 hour	1.1 per cent. (5 tests).
Average gain in less than 8 and over 1 hour.....	3.8 per cent. (8 tests).
Average gain in 3 days	16.2 per cent. (10 tests).
Average gain in 8 days	17.8 per cent. (2 tests).
Average gain in over 8 and less than 43 days	15.3 per cent. (5 tests).
Average gain in 6 months	17.9 per cent. (12 tests).

S. = Slow ; F. = Fast ; M. = Moderate speed.

per cent. heavier load ; while the point at which it was apparently breaking on the first day remained as when first taken from the machine. The second bar behaved in precisely the same manner, the increased resistance amounting to 25 per cent.

Captain Beardslee subsequently made for the Navy Department a very large number of determinations of the amount of this increase, and reported the results to the United States Board. The table opposite is the record of tests upon the ultimate strength, extending the period of rest or "refreshment" from one minute to six months.

Nothing is determined positively by this series of tests as regards the action of this law as affecting the ductility ; for, although the iron was probably of as uniform a structure as it is possible to produce with a set of bars of various diameters, yet there were differences in their characteristics, as found by various tests, which would probably affect some of the minor results in this series. Judged by the change of form alone, it would seem that the ductility of the material was slightly lessened.

The reduction of area of the same iron as shown :

	PER CENT.
By 23 test pieces, broken by a continued strain was	47.5
" 5 " " after rests of 1 to 3 minutes	48.5
" 8 " " after rests of 1 to 8 hours.....	47.2
" 12 " " after rests of 3 to 8 days.....	44.5
" 17 " " after rests of 18 days to 6 months.....	43.1

An examination of the records of pieces broken by a single continued strain shows that there were, with the latter, variations in reduction of area quite as great as those which, in this series, seem to indicate that an increase of the period of rest lessens the ductility.

The elongation was irregular ; that of those broken at once, and of those after six months' rest, coinciding at 29 per cent., while intermediate cases varied from 27.5 per cent. to 30 per cent.

The following record shows that the quality of iron greatly

affects the extent of this elevation of the normal series of elastic limits by intermitted stress:

TABLE CVIII.
EFFECT OF REST UPON IRONS. (U. S. Repts., 1901.)
"Common Refined Iron."

No. of Test.	Primitive Elastic Limit per Square Inch.	Overstraining Load per Square Inch.	Permanent Set.	Interval of Rest.	Secondary Elastic Limit per Square Inch.	Gain per Square Inch.	Tensile Strength per Square Inch.	Elongation.	Contraction of Area.
	Pounds.	Pounds.	Percent	Days.	Pounds.	Pounds	Pounds.	Percent	Per cent.
7407	31,000	48,220	19	32.1
a7411	27,800	30,000	.731	1	30,000	0	43,020	9.6	21.5
7414	34,000	35,000	1.890	1	38,000	3,000	50,800	22.4	36.4
7412	35,500	40,000	3.0	1	43,500	3,500	53,930	22.7	36.4
7413	35,400	45,000	6.6	1	49,500	4,500	53,000	19.6	33.5
7427	31,600	35,000	2.254	7	39,000	4,000	51,600	15.8	26.1
7428	33,000	40,000	4.1	8	46,500	6,500	54,800	22.1	36.4
7429	35,000	45,000	5.8	8	50,000	5,000	57,400	19.3	29.1
"Best Iron."									
7409	30,000	48,000	27.3	39.2
7418	29,000	30,000	2.030	1	32,500	2,500	47,700	27	43.3
7419	29,600	35,000	3.7	1	38,000	3,000	48,100	28.5	44.6
7420	29,400	40,000	6.1	1	44,000	4,000	48,920	27.8	41.9
7433	29,500	30,000	2.078	7	34,700	4,700	48,560	25.9	47.2
7434	29,300	35,000	3.7	7	39,000	4,000	49,560	25.8	43.3
7435	29,400	40,000	7.0	7	45,500	5,500	50,500	24.4	49.7
7436	27,000	30,000	1.857	50	34,000	4,000	49,900	25	43.3
7437	29,100	35,000	4.0	50	40,000	5,000	51,400	25.8	47.2
7438	28,000	40,000	6.7	51	46,000	6,000	52,800	25.2	44.6

These experiments indicate that a structure composed of iron of low ductility will receive comparatively slight benefit from the operation of this law, while ductile, fibrous metal, which possesses greater power to resist sudden strains, although less capable of resisting steady stress, gains in this latter power to a greater extent by the effect of strains already successfully borne.

299. Evidence of Overstrain.—Thus a piece once overstrained, carries, permanently, unmistakable evidence of the fact, and can be made to reveal the amount of such overstrain at any later time with a fair degree of accuracy. This evidence cannot be entirely destroyed, even by a moderate

degree of annealing. Often, only annealing from a high heat, or reheating and reworking can remove it absolutely. Thus, too, a structure, broken down by overstrain, retains in every piece a register of the maximum load to which that piece has been subjected; and the strain-sheet of the structure, as strained at the instant of breaking down, can be laid down.

Here may be found a means of tracing the overstrains which have resulted in the destruction or the injury of any iron or steel structure, and of ascertaining the cause and the method of its failure, in cases frequently happening, in which they are indeterminable by any of the usual methods of investigation.

In illustration of an application of facts known to the determination of the causes and the method of the injury or the destruction of a structure, assume a bridge to have been built with a span of 150 feet, and to have been given such proportions that, with a weight of 1,200 pounds per running foot, and a load of one ton per running foot, the maximum stress on end rods, or other members most strained, is as high as 20,000 pounds per square inch of section of metal. Suppose this bridge to have its tension members composed of a fair, but unrefined, iron, having an elastic limit at about 17,000 pounds per inch (1,195 kilogrammes per square centimetre), and a tenacity of 45,000 to 48,000 pounds (3,164 to 3,374 kilogrammes per square centimetre), and with an extensibility of about 20 per cent.

Suppose this structure to break down under a load exceeding that usually sustained in ordinary work, and portions of the several tension members to be subsequently removed, and, a few days after the accident, to be carefully tested, with the results shown on page 606.

The extensibility is found to be as little as from ten to fifteen per cent.

The tension members are straight bolts without upset ends, the threads being cut, as was formerly common, in such a manner that the section at the bottom of the thread is one-third less than the sectional area of the body of the bar. The location of the tested pieces in the structure being

noted, it is found that the stronger metal, having also the highest elastic limit, came from the neighborhood of the point at which the bridge gave way, and that the weakest metal, and that exhibiting the lowest elastic limit, came usually from points more or less remote from the break. It is not likely that in all cases the increase in the altitude of the elastic limit, and the increase noted in the ultimate strength of the samples would exhibit a regular order coincident with the order of the rods as to position in the structure; since the magnitude and the arrangement of the bars would, to a certain extent, determine the relative amounts of strain thrown upon them by overloading any one part of the truss. For present purposes, we may assume the order of arrangement to be thus coincident.

	ELASTIC LIMIT.		TENACITY.	
	British.	Metric.	British.	Metric.
Sample No. 1.....	16,500	1,160	46,000	3,243
" " 2.....	18,000	1,265	48,000	3,374
" " 3.....	20,000	1,406	48,000	3,374
" " 4.....	22,500	1,582	50,000	3,515
" " 5.....	25,000	1,758	52,000	3,656
" " 6.....	27,500	1,933	52,000	3,656
" " 7.....	28,000	1,968	52,000	3,656
" " 8.....	30,000	2,109	52,000	3,656
" " 9.....	32,000	2,250	53,000	3,726
" " 10.....	34,000	2,390	53,000	3,726

On examination of the figures as above given, the engineer would conclude: First, that the original apparent elastic limit of the iron used in this case must have been not far from 17,000 pounds per square inch, and that its tenacity was between 46,000 and 48,000 pounds; secondly, that this primitive elastic limit had been elevated, by subsequent loads exceeding that amount, to the higher figures given by the bars numbered from 3 to 10 inclusive; thirdly, that the ultimate strength of the material had been, in some examples given above, increased by similarly intermitted strain.

It would be concluded that the ordinary loads, such as had been carried previously to the entrance upon the bridge of that which caused its destruction, never exceeded, in their straining action, 16,500 pounds per square inch of section of tension rod at the part of the truss from which No. 1 had been taken, and that the other rods tested had carried, probably, at the time of the accident, loads approximately equal to those required to strain them to the extent measured by their elastic limits at the time of testing them.

It would be concluded that the rod from which No. 10 was cut was either that most strained by the load, and therefore nearest the point of fracture of the truss, or that it was very near that point, and it would be made the basis of comparison in further studying the case.

As this elastic limit approaches most nearly the breaking strength of the metal, we may apply the formula for the elevation of the elastic limit with time after intermitted strain, which has been above given as derived from tests of a metal of very similar quality. Taking the time of intermission as one week, the extent of the increase has a probable value not far from $E' = 5 \log. 168 + 1.5 =$ nearly $12\frac{1}{2}$ per cent. The magnitude of the stress upon this piece at the time of the accident was therefore 34,000, less one-ninth of that value, or about 30,000 pounds per square inch of cross section of the bar. This corresponds to about 45,000 pounds per square inch at the bottom of the thread, and is within 5 per cent. of the primitive breaking strength of the iron. The bar, if broken at the screwed portion, has therefore yielded under a dead load which was at least equal to its maximum resistance, or under a smaller load acting so suddenly as to have the effect of a real "live load." Or, the slight difference here noted may be due to a flaw at the point of fracture. However that may be, it is almost certain that the body of the rod has sustained a stress of not far from 30,000 pounds per square inch.

But it is found, on further investigation, that the load on the structure at the time of the accident was but sufficient to make the maximum stress on these rods—if properly distrib-

uted—20,000 pounds per square inch (1,406 kilogrammes per square centimetre) at the threaded part of the piece, which piece, it has been seen, has been broken by a strain nearly double that figure. The fact is at once inferable that the load came upon these members with such suddenness as to have at least the effect of a live load, and giving a maximum stress equal to twice that produced by the same load gradually applied, *i. e.*, the case in which the load falls through a height equal to the extension of the piece strained by it, the resistances being assumed to increase directly as the extension up to the point of rupture—an assumption which is approximately correct for brittle materials like hard cast iron, but quite erroneous in the case of some ductile materials, which latter sometimes give a “work of ultimate resistance” amounting to three-fourths or even five-sixths of the product of maximum resistance by the extension.

This accident was therefore caused by the entrance upon the bridge of a load capable of straining the metal to about one half of its ultimate strength, if slowly applied, but which, in consequence of its sudden application, doubled that stress. This sudden action may have been a consequence either of its coming upon the structure at a very high speed, or a result of the loosening of a nut, or of the breaking of a part of either the bridge floor or of one of the trucks of the train. The latter occurrence, permitting the load to fall even a very small distance, would be sufficient.

300. Effect of Orthogonal Strains.—In whatever direction the stress may be applied, and whatever the line of strain, the effect is the same so far as it concerns the normal elastic limit.

Iron and steel wires broken by tension are found to have the transverse elastic limit abnormally elevated, and to have become very stiff and of comparatively slight ductility. This is true of wires of some other metals, and of heavier sections of metal. A large quantity of cold-rolled shafting of all sizes, of which both the longitudinal and the transverse dimensions had been altered by rolling cold, when tested by the Author exhibited great increase of stiffness and strength, and

an even more considerable exaltation of the normal elastic limit. Torsion similarly stiffened wires and rods longitudinally, and test pieces longitudinally strained become stiffer against torsionally and transversely applied stress. Thus orthogonal strains mutually affect orthogonal resistances of metals; and the engineer is, by this fact, compelled to study these mutual influences in designing structures in which the stresses approach or exceed, separately or in combination, the normal *primitive* elastic limit of his material.

The following is, in detail, an account of the behavior of a bar of "good merchant iron" under the action of intermittent and successively applied orthogonal strain (transverse succeeded by tension):*

A bar of good bridge or cable iron 2 inches (5.08 centimetres) square and about 4 feet (1.2 metres) long was split longitudinally; one half was cut into tension test pieces, and the other half bent on the transverse testing machine to an angle at the middle of about 120° ; the bent bar was then cut into tension test pieces like the first, and finally all these pieces were broken in tension. On examining the results thus obtained, it was found that the original elastic limit of the metal, as exhibited by the test of the unbent bar, had been exalted by transverse strain in all parts of the bar which had been so strained before being tested by tension. This elevation of the primitive normal limit had not occurred, as would have been expected, to the greatest extent at the points most strained, *i. e.*, nearest the bend at the middle of the strained bar and less and less as the point of maximum strain was departed from, until, at the ends of the bar, this elevation became much less observable, but took place irregularly, and, on the average, about as much at one part as at another.

The elevation of the primitive elastic limit, in this instance, is 30 per cent. as an average, and in some parts of the bar about 50 per cent. The new series of the elastic limits are less uniform in value than in the original bar; but, com-

* *Trans. Am. Society C. E.* Vol. IX., No. cxcii., 1880.

paring adjacent pieces, in no case is the elevation of the limit less than one ton on the square inch, and it usually amounts to more than double that figure. Singularly, also, the greatest change was produced farthest from the middle, and the least at that point. It should be observed that the quality of the bar tested, although good as metal of that size runs in the market, is not high, and is not as regular as it should be. But the transverse strain here produced, and which greatly modified the primitive elastic limit of the metal, had not materially or even observably affected its ultimate tenacity.

Bars of similar iron were subjected to severe lateral compression, increasing their length and decreasing their cross section about 15 per cent. ; then testing the metal by longitudinal strain, *i. e.*, by orthogonal stress.

Lateral compression to a moderate extent may elevate the longitudinal elastic limit nearly 100 per cent., may increase the longitudinal tenacity 33 per cent., and may raise the modulus of elasticity 4 per cent., while decreasing the ductility in the orthogonal direction 60 per cent.

Lateral compression to the extent now practised increases the elastic limit in flexure more than 100 per cent., *reduces* the modulus of elasticity as estimated from flexure 6 per cent., increases the maximum resistance 90 per cent., and nearly doubles the resilience at maximum deflection.

From the fact that the changes produced by cross-bending are felt in internal strain occurring not simply near the point of flexure, but throughout the whole extent of the beam flexed, it would seem that shearing strains are more serious and general than we have hitherto supposed. This latter is a matter of importance in determining a correct theory of transverse strain, and the subject is undoubtedly deserving of extended and careful investigation with a view to discovering precisely the nature and intensity of such strains under all usual conditions in all the materials of engineering construction—first feeling out these strains in the manner here indicated, and then working up the details of the theory, until a complete and satisfactory analysis is attained.

301. Conclusions.—We may now summarize the results

of the study of this subject, so far as the Author has yet presented them, and the conclusions to which he has been conducted.*

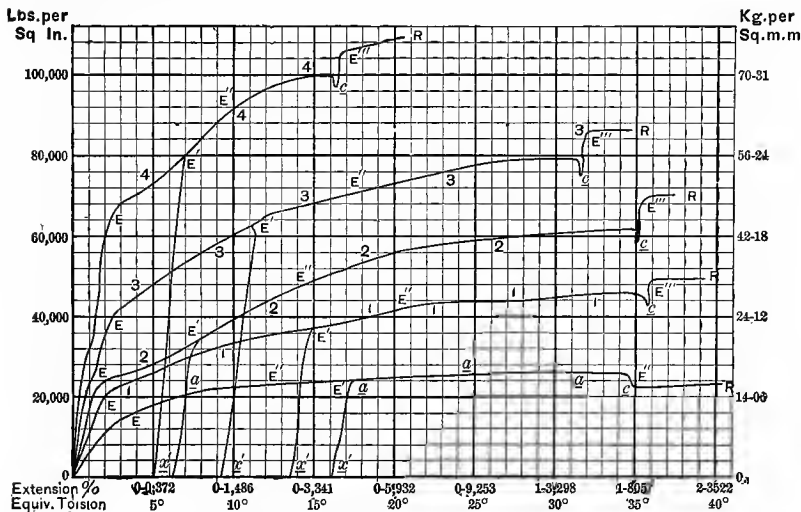

FIG. 139.—AUTOGRAPHIC STRAIN DIAGRAMS.

In the above figure, let 1, 1, 1, 1, represent the strain diagram of a soft malleable (wrought) iron, like Swedish or Norway; let 2, 2, 2, 2, be that of a good common merchant iron of small size; let 3, 3, 3, 3, be the diagram of a mild, and 4, 4, 4, 4, that of a tool steel; while, in contrast to these examples of the "iron class," let a, a, a, a, be the strain diagram of a metal of the "tin class;" for example, a ductile brass or bronze.

When these metals are strained, they are always found to exhibit a gradually increasing resistance pretty nearly proportional to the extent of change of shape, until a point, E, is reached, when the rate of increase of extension becomes greater—usually very much greater—and the deformation remains permanent when the piece is unloaded, and very nearly equal to the distortion under the load. The removal of the load then, if it is not renewed, gives a strain diagram

* *Trans. Amer. Soc. C. E.*, 1880.

O, E, E', x' , the distortion being permanent at x' . This is the natural or "normal" curve, and it exhibits the normal and long-known form of elevation of elastic limit. At the last moment, when the load and distortion are measured by the ordinate and the abscissa, respectively, of the point E' , the elastic limit has become a maximum. Had the piece strained broken at E' the limit of its elasticity would have become identical with the limit of strength and point of rupture, and its measure would have become identical with the modulus of rupture; for, considering the piece as unbroken at this point, the distorted piece would have for its strain diagram the straight line E', x' , and would have now been broken when loaded, at the moment that the stress attained the magnitude measured by the vertical let fall from E' to the base line. The point E on each diagram marks what is usually known as the Elastic Limit. To distinguish this from the successive limits of elasticity which are due to permanent successively increasing strains, the writer has called the natural and original apparent of limit of elasticity, E , the "*Primitive Elastic Limit*," and any other points, E', E'' , in a smooth curve representing a strain diagram exhibiting the effect produced by unintermitted and regular distortion, the "*Normal Elastic Limit*" of the piece when in such condition of deformation, the whole curve being, as has been stated, a "*Curve of the Loci of successive Elastic Limits*."*

This normal elevation of the elastic limit, therefore, as strain progresses and permanent deformation increases, occurs regularly, and the strain diagram takes the form of a smooth curve, such as has been long known to represent it, and such as will be found in Morin's "*Resistance des Matériaux*" and other works published during the last quarter century.

But, instead of producing a regularly increasing deformation by regularly increasing stress, let load be steadily added

* On the Mechanical Treatment of Metals, and on the Elevation of the Elastic Limit. R. H. Thurston.—*Metallurgical Review*, 1877.

Ueber die Natur der Elasticitätsgrenze und die Art Ihrer Veränderungen. R. H. Thurston.—*Dingler's Polytechnisches Journal*, 1877.

until at some point E''' , corresponding to a distortion O, E''' , further addition of load ceases, and the piece remains permanently distorted. The metal now gradually yields, and there occurs a depression, c , of the elastic limit, which in the iron class soon reaches a limit, but in the tin class, if the load be not wholly or partly removed, may continue until rupture or maximum possible deformation takes place. Now, renewing the stress, it is invariably observed that this depression of elasticity is, in the case of the iron class, only apparent; for the extension of the strain diagram now takes place at a higher range, $E''' R$, and we observe at E''' that phenomenon of "Exaltation of the Normal Elastic Limit" which has been studied by the writer, as seen at E''' in curves 1, 2, 3 and 4, and which has until recently been unnoticed by authorities.

Making the same experiment on metals of the tin class, we usually observe the depression of the normal succession of elastic limits which distinguishes this class from the first, as at E''' in a, a, a, a ; sometimes, however, this depression is unobservable.

This distinction between the two kinds of metals has been shown to have peculiar importance in its bearing upon the permissible values of the factor of safety in structures of metal, the value allowable in constructing in iron or steel being lower, and that demanded in parts composed of the second class of metals being higher than would be proper, except for this singular characteristic. Studying the effect of rapidity of distortion, we find that in the case of the iron class greater rapidity of distortion causes a decreased resistance, and that a slowly produced deformation causes relatively higher resistance, while the opposite is the case with metals of the second class.* We see that the rate of set is also related to the time allowed for it.† It thus happens that with the same metals strained at such a rate

* Kirkaldy finds an average difference of twenty per cent. between resistances under slowly and suddenly applied loads. *Vide* Resistance of Materials as affected by Flow and by Rapidity of Distortion. *Trans. Am. Soc. C. E.*, 1876-7.

† On the Rate of Set of Metals. *Ibid.*

as to give a strain diagram 1, 1, 1, 1, an accelerated distortion may produce the diagram 2, 2, 2, 2, or the diagram *a, a, a, a*, accordingly as the metal is of the first or the second class.

Still further, it has been shown that the exaltation of the elastic limit in iron, etc., is not confined to the direction of the strain produced, but that it affects the metal in such manner as to give it an exalted elastic limit with respect to all subsequent strains, however applied. Thus, the engineer may make use of any method of strain that he desires or that he may find convenient, to secure the condition of increased stiffness that he may desire in any given direction. He may strain his bars in tension to secure stiffness in either tension, compression, or transversely, or he may give his bars a transverse set to obtain a higher elasticity in all the other directions; or he may compress the metal, as by cold-rolling, and thus secure enhanced stiffness and elasticity in either longitudinal or transverse directions.*

Finally, the Author having shown that the exalted elastic limit being a permanent and determinable effect of any strain which exceeds the "primitive elastic limit," it must remain a permanent and inefaceable record of the maximum load borne by the metal; this fact is seen to be of importance, as it enables the engineer to trace such distribution of strain as may have occurred in a wrecked structure,† to determine the location of defective and flawed pieces, and to ascertain the distribution of strains generally, whether in structures or in single members.

Cooper describes a counter-brace taken from a bridge in which it had, in consequence of maladjustment, been subjected to frequently recurring shock until finally broken, the test of which gave the following:

* See report by the Author, "On the Strength, Elasticity, Ductility, and Resilience of Cold-rolled Iron and Steel." Pamphlet, 8vo, Pittsburgh, 1878.

† On a new Method of Detecting Overstrain, etc., and its Application in the Investigation of Causes of Accident to Bridges and other Structures. *Trans. Am. Soc. C. E.*, March, 1878.

Tenacity, 44,000 lbs. per square inch (3,093 kilogrammes per square centimetre).

Elastic limit, 36,000 lbs. (2,531 kilogrammes).

Fractured section = Original section.

Elongation, *none*.

Fracture, crystalline ; facets large.

In this case the crystalline structure is reported to be well developed, and the change would seem to have occurred while in service. The elevation of the elastic limit nearly to the maximum tenacity, while the latter remains very low—and may perhaps have been simultaneously reduced—is evidence of a change of structure of cold metal by shock.

Professor Kick, experimenting with lead, finds that when subjected to the action of the steam-hammer, the deformation produced was sensibly affected by the suddenness of the shock. A heavy weight, resting on the mass of lead and crushing it, produced a greater deformation than the same weight falling from a considerable height. With such soft metals, flow continues, when once started, indefinitely. Kick found that the *work* expended in producing a certain deformation of the lead in one minute is five times as much as when the time allowed for the action is indefinitely great. This investigation leads to the conclusion that the most economical method of shaping such soft bodies, and probably including iron and steel at the welding heat, is by steady pressure rather than by blows, by hydraulic forging rather than by hammering. These conclusions have been confirmed by the Author when comparing the slow action of the testing machine with that of a falling weight, in crushing copper.

302. Cold Rolling produces an effect upon iron and steel which depends both upon the method and extent of the operation, and, in quite as important a degree, upon the nature of the material. Hard iron cannot be safely cold rolled to any considerable extent, and hard steel cannot be subjected to the process at all. Soft steel will bear a moderate amount of reduction by cold rolling, and the very softest ingot iron, used for boiler plate by the best makers, is

as greatly and as usefully modified by the process as are the best irons. This treatment has been principally confined to the working of the best grades of pure, soft, puddled iron.

An extended investigation* made by the Author led to the following conclusions:

(1.) The process of cold rolling produces a very marked change in the physical properties of the iron thus treated.

It increases the tenacity from 25 to 40 per cent., and the resistance to transverse stress from 50 to 80 per cent.

It elevates the elastic limit under torsional as well as tensile and transverse stresses, from 80 to 125 per cent.

The elastic resilience is elevated from 300 to 400 per cent. The elastic resilience in transverse stress is augmented from 150 to 425 per cent.

(2.) Cold rolling also improves the metal in other respects:

It gives the iron a smooth, bright surface, absolutely free from the scale of black oxide unavoidably left when hot-rolled.

It may be made exactly to gauge, and for many purposes requires no further preparation.

In working the metal, the wear and tear of the tools are less than with hot-rolled iron, thus saving labor and expense in fitting.

The cold-rolled iron resists stresses much more uniformly than does the untreated metal. Irregularities of resistance exhibited by the latter do not appear in the former; this is more particularly true for transverse stress, as is shown by the smoothness of strain-diagrams produced by cold-rolled bars.

This treatment of iron produces a very important improvement in uniformity of structure, the cold-rolled iron excelling common iron in its uniformity in density from surface to centre, as well as in its uniformity of strength from outside to the middle of the bar.

(3.) This great increase of strength, stiffness, elasticity and resilience is obtained at the expense of some ductility, which

* Report on Cold-rolled Iron and Steel, Pittsburgh, 1878; Private Print.

latter diminishes as the tenacity increases. The ultimate resilience of the cold-rolled iron is, however, above 50 per cent. of that of the untreated iron.

Cold-rolled iron thus greatly excels common iron in all cases where the metal is to sustain maximum loads without permanent set or distortion.

Comparing the autographic strain-diagrams, it was concluded:

(1.) That the curves exhibit the same peculiarities that are observed when testing these metals by transverse stress, and by tension. The diagrams of the cold-rolled iron, after the elastic limit is passed, gradually fall into a horizontal line; while those of the untreated metal turn abruptly and generally show a counter-flexure in the curve just beyond the elastic limit.

(2.) That the diagrams of the annealed cold-rolled iron still retain some of the characteristics of those of the unannealed.

(3.) That the result of the treatment of the metal is the elevation of the elastic limit more or less nearly to the limit of strength observed at final rupture, and the change of the method of passing the elastic limit, making that change far less abrupt, and giving a smoother and more symmetrical curve than that noted on the strain-diagrams of the hot-rolled metal.

Collating the results of several hundred tests, the Author found that the modulus of elasticity rose, in cold rolling, from about 25,000,000 pounds per square inch (1,757,500 kilogrammes per square centimetre) to 26,000,000 (metric, 1,827,800); the tenacity from 52,000 pounds (3,640.6 kilogrammes) to nearly 70,000 (4,921 kilogrammes); the elastic limit from 30,000 pounds (2,109 kilogrammes) to nearly 60,000 (4,218 kilogrammes per square centimetre); and the extension was reduced from 25 to 10½ per cent.*

Transverse loads gave a *reduction* of the modulus of elasticity to the extent of about 1,000,000 pounds per square inch (700,000 kilogrammes per square centimetre), and increase of

* Ibid , p. 109.

the modulus of rupture from 73,600 to 133,600, and reduction of the deflection at maximum load of about 25 per cent. The resistance of the elastic limit was doubled, and occurred at a much greater deflection than with untreated iron.*

The effect of cold-punching has already been described in Articles 274 and 275.

Egleston, studying the behavior of metal under long-continued and repeated stresses, finds evidence of the existence of a "law of fatigue and refreshment of metals," occurring as indicated by the Author (Art. 301). He also concludes † that metal once fatigued may sometimes be restored by rest or by heating; that "the change produced is a chemical one," accompanied by "a change in the size, color and surface of the grains of the iron or the steel." Surface injuries by blows were found to affect the metal, in some cases, to a depth of 15 millimetres (0.6 inch). He informs the Author that he finds evidence of the formation of crystals in the cold metal during the process of becoming fatigued, and a decided change in the proportion of combined and uncombined carbon.

303. The Effect of Repeated Variation of Load is most important. In the year 1859 Prof. Wöhler, in the employ of the German Government, undertook a series of experiments to determine the effect of prolonged varying stress on iron and steel. These experiments were continued until 1870. The apparatus used by Wöhler and his successor, Spangenberg, was of four kinds:

- (1.) To produce rupture by repeated load.
- (2.) For repeated bending, in one direction, of prismatic rods.
- (3.) For experiments on loaded rods under constant bending stress.
- (4.) For torsion by repeated stress.

The amount of the imposed stress was determined by breaking several rods of like material, ascertaining the breaking load, and taking some fraction of this for the intermittent load.

* Report, p. 108.

† *Transactions Institute Mining Engineers*, 1880.

From the results of these experiments of Wöhler, extending over eleven years, the observations here appended were deduced :

“WÖHLER’S LAW: *Rupture of material may be caused by repeated vibrations, none of which attain the absolute breaking limit. The differences of the limiting strains are sufficient for the rupture of the material.*”

The number of strains required for rupture increases much more rapidly than the weight of load diminishes.

The work of Wöhler and Spangenberg has proven what was long before supposed to be the fact: that the permanence and safety of any iron or steel structure depends not simply on the greatest magnitude of the load to be sustained, but on the frequency of its application and the range of variation of its amount. The structure or the machine must usually be designed to carry indefinitely whatever load it is intended to sustain and to be permanently safe, however much the stress may vary, or however frequent its application. The stress permitted and calculated upon must therefore be less as the variation is greater, and as the frequency of its application is greater. Although it is customary to make the working load one fifth or one sixth the maximum load that could be sustained without fracture, it has now become well known that this is not the correct method except for an unvarying load ; although, as will be seen, these factors of safety are sufficient to cover the case studied by Wöhler.

Wöhler found that good wrought iron and steel would bear loads indefinitely as follows :

	Lbs. per sq. in.	Kilogs. per sq. cm.
Wrought iron, tension only	+ 18,700 to + 30	+ 1,309 to + 2.2
Wrought iron, tension and compres. +	8,320 to - 8,320	+ 582 to - 582
Cast steel, tension only	+ 34,307 to + 11,440	+ 2,401 to + 801
Cast steel, tension and compression. +	12,480 to - 12,480	+ 874 to - 874

Thus rupture is produced either by a certain load, called usually the “breaking load,” once applied, or by a repeatedly applied smaller load. The differences of stresses applied, as well as their actual amount, determine the number of appli-

cations which may be made before fracture occurs, and the length of life of the member or the structure. This weakening of metal by repeated stresses is known as "*fatigue*." It is not known that it may always be relieved, like internal stresses, by rest; but it is apparently capable of relief frequently by either simple rest for a considerable period, or by heating, working and annealing.

The experiments of Wöhler, Vicat, Fairbairn and the Author, already described, seem to indicate some relation between the action of variable loads and of prolonged stress where metals are soft enough to "flow."

LAUNHARDT'S FORMULA is also adopted by many engineers, as the best expression of Wöhler's Law, in the determination of the proportions of parts of structures.

When t is the ultimate strength under a single application of a statical load, u is the smaller stress which may be repeatedly applied through an indefinite period without producing rupture; if c is the minimum stress when the load is not wholly removed after each application, and if a is the load barely sustainable, a and c alternating, the difference is $d = a - c$, and $a = c + d$; Launhardt takes

$$a = f(d),$$

$$= u \left(1 + \frac{t - u}{u} \cdot \frac{c}{a} \right) \dots (4)$$

The ratio $\frac{c}{a}$ is the minimum divided by the maximum sustainable stress, a ratio, called by Launhardt $\frac{\min B}{\max B} = \varphi$, which will have different values for different materials and for different kinds of stress. When the two stresses applied are of opposite kinds, as when the piece is strained alternately in tension and compression, or by reversed torsional strain, this factor becomes negative. The formula is thus written:

For tension or compression alone, $\frac{c}{a}$ positive;

$$a = u \left(1 + \frac{t - u}{u} \varphi \right) \dots \dots \dots (5)$$

For alternate tension and compression, $\frac{c}{a}$ negative ;

$$a = u \left(1 - \frac{t - u}{u} \varphi \right) \dots \dots \dots (6)$$

The constants taken by Weyrauch* from Wöhler's experiments are, the subscript *m* denoting metric measures :

For iron ; in flexure,

$$t_m = 4,020 ; u_m = 2,195 ;$$

$$\frac{t - u}{u} = \frac{5}{6} ;$$

in tension,

$$t_m = 3,290 ; u_m = 2,190 ;$$

$$\frac{t - u}{u} = \frac{1}{2} .$$

The formulas thus become, for this case, in metric measures, nearly

$$a_m = 2,100 \left(1 + \frac{1}{2} \varphi \right) \dots \dots \dots (7)$$

in British measures,

$$a = 30,000 \left(1 + \frac{1}{2} \varphi \right) \dots \dots \dots (8)$$

For alternate tension and compression,

$$t_m = 2,190 ; u_m = 1,170 ;$$

$$\frac{t - u}{u} = \frac{7}{15} ;$$

* Du Bois' Weyrauch, *Structures of Iron and Steel*. N. Y., J. Wiley & Sons, 1877.

$$a_m = 2,100 \left(1 - \frac{1}{2} \varphi \right) \text{ nearly } \dots \dots \dots (9)$$

$$a = 30,000 \left(1 - \frac{1}{2} \varphi \right) \dots \dots \dots (10)$$

For rather low cast steel, $\frac{c}{a}$ positive ;

$$t_m = 7,340 ; u_m = 3,510 ;$$

$$\frac{t - u}{u} = \frac{7}{6} ;$$

in metric measures,

$$a_m = 3,500 \left(1 + \frac{7}{6} \varphi \right) \dots \dots \dots (11)$$

in British measures,

$$a = 50,000 \left(1 + \frac{7}{6} \varphi \right) \dots \dots \dots (12)$$

When $\frac{c}{a}$ is negative :

$$a_m = 3,500 \left(1 - \frac{5}{12} \varphi \right) \dots \dots \dots (13)$$

$$a = 50,000 \left(1 - \frac{5}{12} \varphi \right) \dots \dots \dots (14)$$

For spring steel, tempered :

$$a_m = 4,200 \left(1 \pm \frac{3}{2} \varphi \right) \dots \dots \dots (15)$$

$$a = 60,000 \left(1 \pm \frac{3}{2} \varphi \right) \dots \dots \dots (16)$$

A factor of safety considerably smaller than usually found

safe can evidently be adopted with this method of calculation.

Weyrauch makes this factor 3.

Extended experiment only can determine new values of u .

Mohr* and other writers have shown that the application, above illustrated, of such formulas amounts to the application of a factor of safety of about 3 or 3.5. The cases to meet which this treatment is proposed are fully covered by the factors of safety customarily adopted by engineers.

Similar conclusions to those of Wöhler had already been reached by Fairbairn in 1860. A built beam capable of carrying nine and a half tons (or tonnes) on the middle, with 20 feet (6.1 metres) span, was loaded with one-fourth this breaking weight, bringing a stress of 4.3 tons per square inch (6,767 kilogrammes per square centimetre) on the lower flange, a load exceeding the Board of Trade limit by nearly 25 per cent. The beam was then deflected $\frac{1}{8}$ of an inch (0.42 centimetre) a half million times, giving it a set of 0.01 inch (2.54 millimetres) without apparent weakening or injury.

The load was then increased to $\frac{1}{4}$ the breaking weight, and one million deflections of nearly $\frac{1}{4}$ inch (0.64 cm.) left it still uninjured. Increasing the load to one-half the breaking weight, the beam was finally broken by 5,175 deflections. It was repaired and subjected to a total of 4,000,000 deflections, of which the last 2,727,154 were under a load $\frac{1}{8}$ the breaking weight, and was finally removed unbroken.†

Wrought iron in axles is found to have a long life if not strained beyond about 9,000 pounds to the square inch (630 kilogrammes per square centimetre).

The *practical proof strain* is determined by taking one-half of the intensity of the stress the piece can sustain a certain

* *Der Civilingenieur*, 1881.

† The Author has recently, in testing a Corliss steam engine, observed that the springs closing the steam valves when "tripped," remain apparently as elastic and as stiff as when new, although they had made at least 200,000,000 vibrations under their load. They were made of spring steel, two "leaves," each $\frac{3}{16}$ inch ($\frac{1}{2}$ cm.) thick and 27 inches (68.6 cm.) long.

maximum number of times without injury. For example, Wöhler found that a rod of Krupp's cast steel, under a maximum load of 31,132 pounds per square inch (2,188 kgs. per sq. cm.), was broken after the load had been applied 45,000,000 times; if this metal had been used in an axle making 30,000 revolutions a day, or 9,000,000 per year, then for five years' duration it might be subjected to a load of 15,566 pounds per square inch (1,094 kilogrammes per centimetre).

Vibrations take place on bars loaded to the following limits with equal security against rupture by tearing and crushing:

TABLE CIX.

MAXIMUM LOADS.

	Lbs. per sq. in.	Kilogs. per sq. cm.	and	Lbs. per sq. in.	Kilogs. per sq. cm.
Good iron, between	16,634,	11,689,	and	16,634,	11,689
	31,132,	2,188,	"	0	0
	45,734,	3,215,	"	24,941,	1,753
Axle steel, between	29,103,	2,046,	and	29,103,	2,046
	49,896,	3,507,	"	0	0
	83,113,	5,843,	"	36,386,	2,557
Spring steel, not hardened, between	52,000,	3,655,	and	0	0
	72,736,	5,113,	"	25,520,	1,793
	83,113,	5,843,	"	41,505,	2,921
	93,505,	6,576,	"	62,246,	4,376
For shearing resistance:					
Axle steel, between	22,828,	1,607,	and	22,828,	1,607
	39,443,	2,772,	"	0	0

For good wrought iron Wöhler concludes the maximum strain permissible, where the structure is to be permanent, is 8,317 pounds per square inch (584 kilogs. per sq. cm.).

Piston-rods, connecting-rods, links, etc., which are subjected to alternate pull and thrust, should be made about $\frac{2}{3}$ as strong as parts bearing but one kind of stress.

Prof. L. Spangenberg resumed the line of experiments at the point of its discontinuance by Wöhler, and his results tend to confirm the law of the latter. Spangenberg directed his attention to other metals than iron and steel, and also endeavored, by inspection of the surfaces of fracture, and by

his hypothesis as to the molecular constitution of metals, to explain the phenomena of fracture. Among the several observations noted in his "Fatigue of Metals," is the important fact that when subject to often-repeated transverse stress, fracture of iron took place only on the tension side of the bar, and extended only to the neutral axis. From this he inferred that the *working strength* of wrought iron is less than its elastic resistance.

Fowler states, in this connection, that a steel or an iron rail tested for transverse strength in a machine, will, as a rule, bend many inches, and fail by distortion of the head under the compressive stress. In actual work hundreds of such rails break, but it is the tensile and not the compressive stress which causes the failure, and there is no distortion of the head, as in the testing machine. Similarly, when riveted girders break under traffic, it is not the top flanges with a calculated stress, on the average, of about one-third of the ultimate resistance, that give way, but the bottom members, where the calculated stress is only about one-fourth of the ultimate resistance. The universal experience is that fatigue is far more injurious to iron or steel under tensile than under compressive stress, and it follows that the factor of safety should not be the same in the two cases. This is quite consistent with ordinary practice, as probably the majority of girder bridges have equal sized top and bottom flanges, which, after allowing for the riveting, would give a factor of about 3 for the compression and about 4 for the tension members, respectively.

Taking in Launhardt's formula,

$$a = u + (t - u)\varphi,$$

$$a = u + (u - s)\varphi,$$

in which a is the minimum stress on the member strained; s is the transient compressive, alternating with equal tensile stress; t the safe permanent load; u the safe load when alternately applied and removed; φ = the ratio minimum

stress divided by the maximum, Fowler obtains results as below.

The first of the two formulas is used when $\frac{c}{a}$ is positive, the second when negative, *i. e.*, when two stresses are of the same or of opposite kinds.

Adopting values of t , u , and s obtained by Weyrauch, as follows, Fowler obtains the values in the table below for a , all in tons per square inch.*

Wrought iron..... $t = 20.84$; $u = 13.94$; $s = 7.43$.
 Krupp's steel..... $t = 46.6$; $u = 22.28$; $s = 13.02$.

TABLE CX.

VALUES OF a ; TONS PER SQUARE INCH.

φ	1.	0.9	0.8	0.7	0.6
a Wrought iron.....	20.8	20.2	19.5	18.8	18.1
a Steel	46.4	44.2	41.8	39.3	36.9
$\frac{m}{M}$	0.5	0.4	0.3	0.2	0.1
a Wrought iron.....	17.4	16.7	16.0	15.3	14.6
a Steel	34.5	32.0	29.6	27.1	24.7
$\frac{m}{M}$	- 0.1	- 0.2	- 0.3	- 0.4	- 0.5
a Wrought iron.....	13.3	12.6	12.0	11.3	10.7
a Steel	21.3	20.4	19.5	18.6	17.6
$\frac{m}{M}$	- 0.6	- 0.7	- 0.8	- 0.9	- 1.0
a Wrought iron.....	10.0	9.4	8.7	8.1	7.4
a Steel	16.7	15.8	14.9	14.0	13.0

For kilogrammes per square centimetre multiply by 158.

Wöhler concluded that the allowable loads for the cases

* Molesworth.

of stationary loading, loading in tension alternating with entire relief, and equal and alternate tensions and compressions, will be in the ratio 3 : 2 : 1.

The method above described is still in the experimental stage ; but it may be provisionally accepted as safer than the usual method of covering cases of varying stresses by a factor of safety determined solely by custom or individual judgment. It has been the custom, with some American bridge builders, to give members in alternate tension and compression a section equal to that calculated for a tension under static load equal to the sum of the two stresses—a rough method of meeting the most usual and serious case.

French engineers, commenting upon the work of Wöhler, Spangenberg, Weyrauch* and Launhardt, consider that the result is simply to base upon the ultimate strength a deduced limit of working stress which corresponds closely to the elastic limit, and generally urge that reasonable factors of safety *related to the limit of elasticity* are preferable to the still uncertain method above described.† It is admitted, however, that the results accord with those already indicated by experience where a definite practice has become settled upon.

Bauschinger also finds that the maximum load for safety, with alternating or variable stresses, is found at or just below the original yielding point, the “primitive elastic limit,” where rapid strain occurs under steadily increasing loads ; and the investigations of the Author, elsewhere cited, indicate, with both wood and metal, that a real factor of safety of 2 is, in such cases, sufficient to meet this condition ; and double this, 4, is advised as a minimum.

* Various Methods of Determining Dimensions ; Dr. J. Weyrauch ; translated by G. R. Bodmer ; *Proc. Inst. C. E.*, 1882-3, Vol. LXXI.

† *Résumé de la Société des Ingénieurs Civils*, 1882.

CHAPTER XI.

SPECIFICATIONS ; TESTS ; INSPECTION.

304. **The Specification** forms an indispensable part of every contract under which a construction is to be made. It describes minutely and specifically the design, the method of construction, the kind, quantity, and quality of the materials of which it is to be made, and the method of inspection and test of its parts, and of the completed structure. One of the most important parts of this document is that which prescribes the quality of material, the strength of parts, the method of inspection, and the character of the tests to be applied by the inspector.

The Kind of Metal used will depend upon the character of the work, its extent and importance, and the relative expense of the several kinds of iron or steel that may be used. *Cast iron*, from its cheapness, is especially adapted for use in constructions where weight is no objection, where solidity is an advantage, and where its deficiency in strength, ductility, and resilience can therefore be compensated by increased size as compared with wrought iron or steel. Pieces which cannot be worked into shape in the rolls or under either the hammer or the press, are necessarily made in cast iron. When extraordinary strength is demanded, "gun-iron" castings are made, melting the iron in the "air-furnace" instead of in the cupola. When still greater strength and ductility are demanded in cast metal, malleableized cast iron or steel castings are specified.

Castings are usually expected to be made of tough gray iron, No. 3 grade, cast in dry sand, sound, smooth, exact in size, and reasonably uniform in weight. A tenacity of 25,000 pounds per square inch (1,757.5 kilogrammes per square centimetre) is often called for but seldom obtained, except in

gun-iron, which can be supplied to a specification of 30,000 pounds (2,109 kilogrammes).

The thickness of castings is rarely less than $\frac{3}{4}$ inch (1.9 centimetres), however small the load, as sound castings cannot be expected in thinner iron when of any considerable size. The larger the casting, also, the less the strength calculated upon.

Cold-blast charcoal irons are best, but most expensive. When properly mixed, melted in the reverberatory, or air-furnace, and cast in dry sand, they make the strongest and best of castings.

Chilling irons are required for car-wheels and for a few other purposes. They are costly, but exceedingly strong and tough. These are usually charcoal irons, although some well-known brands are anthracite.

Castings subject to wear, as steam-engine cylinders, are made as hard as the tools will work them. Castings which are required to be massive, and in which tenacity is unimportant, are made of the least costly iron obtainable, without regard to brand. (See Appendix.)

Wrought iron and steel, as has been seen, are very variable in strength and other qualities. For small iron parts, a tenacity of 55,000 to 60,000 pounds per square inch (3,867 to 4,218 kilogrammes per square centimetre) is usually called for; but the strength of large masses is rarely three-fourths as great. The specification usually calls for "iron of the best quality," tough, of a definite tenacity, fibrous, free from cinder-streaks, flaws, lamination or cracks, uniform in quality, and with a prescribed elastic limit, and often a stated modulus of elasticity. Even the method of piling, heating, and rolling or hammering is specified. Thus Lovett's specifications for rails for the Cincinnati Southern Railroad,* prescribe that the piles shall be composed of 35 per cent. crystalline hammered iron for the head, 30 per cent. puddled bar in the web, and 35 per cent. fibrous iron for the bottom flange, the slabs breaking joint. Heating is to be done top-

* Haupt's Specifications and Contracts, p. 177.

side up, and the hammer must be five tons or more in weight.

As has been shown fully in the preceding chapters, the dimensions must be determined after a careful consideration of the character and the method of application of the load, as well as of its magnitude, and allowance must be made by the engineer for the effect of heat or cold, of repeated heating in the process of manufacture, for the rate of set under load, for the rapidity of its application or for the effect of repeated or reversed strains.

The differences in the behavior of the several kinds of iron or steel under the given directions must be considered in proportioning parts. Thus unannealed iron or "low" steel will be chosen for parts exposed to steady and heavy loads; the use of annealed metal will be restricted to cases in which the primary requisite is softness or malleability; steel containing about 0.8 per cent. carbon will be given the preference for parts exposed to moderate blows and shocks which are not expected to exceed the elastic resilience of the piece; tough, ductile metal, preferably "ingot iron," will be chosen for parts exposed to shocks capable of producing great local or general distortion.

"Wöhler's Law" dictates the adoption of increased factors of safety, or of some equivalent device, as Launhardt's formula, when variable loads are carried. Thus, the engineer is compelled to make a specification, in every important work, which shall prescribe all the qualities of materials and exactly the proportions of parts needed to make his work safe for an indefinite period.

Steel has such a wide range of quality that few difficulties are met with in its introduction into any department of construction. In boiler work, however, it must be kept low in carbon and therefore in tenacity; and in machinery and bridge work, also, its composition must be carefully determined upon and as exactly specified. For many purposes, standard methods of inspection and test are coming to be generally adopted.

In designing parts of variable section, the engineer will

find it advisable to make no sharp corners, whether in castings or forgings, as fracture is sure to be precipitated by over-fatigue at such places; this and similar points must be covered by the specification.

305. Specifications for Boiler Work.—Steel Sheets.—

Grain—To be uniform throughout, of a fine close texture.

Workmanship—Sheets to be of uniform thickness, smooth finish, and sheared closely to size ordered.

Tensile Strength—To be 60,000 pounds to square inch for fire-box sheets, and 56,000 pounds for shell sheets.

Working Test—A piece from each sheet to be heated to a dark cherry red, plunged into water at 60°, and bent double, cold, under the hammer; such piece to show no flaw after doubling (Figure 140).



FIG. 140.

Iron Sheets.—Grain—To be uniform throughout, showing a homogeneous metal with no layers or seams. *Workmanship*—Sheets to be of uniform thickness, smooth finish, and sheared closely to size ordered. *Tensile Strength*—To be 55,000 pounds to the square inch for fire-box sheets, and 50,000 pounds for shell sheets. *Working Test*—A piece from each sheet to be bent cold to a right angle, showing no fracture. A piece bent double, hot, to show no flaking or fracture.

Specifications for Boiler Tubes.—Size—Locomotive tubes to be 12 feet long and 2 inches diameter; to be of iron, No. 11 gauge. *Quality of Metal*—When flattened under the hammer to show tough fibrous grain; when polished and etched with acid to show uniform metal and a close weld. *Working Test*—When expanded and beaded into the flue sheet to show no flaws; to stand “swaging down” hot without flakes or seams.

The following are the specifications for *Boiler and Fire-Box Steel* issued by the Pennsylvania Railroad Company, February 1, 1881:

(1.) A careful examination will be made of every sheet, and none will be received that show mechanical defects.

(2.) A test strip from each sheet, taken lengthwise of the

sheet, and without annealing should have a tensile strength of 55,000 pounds per square inch, and an elongation of thirty per cent. in a section originally two inches long.

(3.) Sheets will not be accepted if the test shows a tensile strength of less than 50,000 or greater than 65,000 pounds per square inch, nor if the elongation falls below twenty-five per cent.

(4.) Should any sheets develop defects in working they will be rejected.

(5.) Manufacturers must send one test strip for each sheet (this strip must accompany the sheet in every case), both sheet and strip being properly stamped with the marks designated by the company, and also lettered with white lead, to facilitate marking.

The U. S. Board of Supervising Inspectors of steam vessels restrict the stress on *Boiler Stays* and *Braces* to 6,000 pounds per square inch (4,218 kilogrammes per square centimetre). For *Shells* of boilers, a factor of safety of 6 is permitted in designing. The hydrostatic pressure applied in testing is one-half greater than the steam pressure allowed. All plates must be stamped by the maker with the tenacity, as determined by test, at the four corners and in the middle. The elongation is not noted, as the form of United States standard test piece is unfitted to determine it. The contraction of area of section at fracture must be 0.15 when the tenacity is 45,000 pounds, and one per cent. *more* for each additional 1,000 pounds.

306. Hot-short, or Red-short, and Cold-short Irons are detected by the forge tests; the former is often found to be an excellent quality of iron, if it can be worked into shape, as it is, when cold, tough and strong. Specially high qualities are rarely economical, as they usually cost too much to make the difference worth what is paid for it. Shapes difficult to make or roll are usually weaker than others. Mills will usually supply "pattern iron," charging a little extra for it; but it will often be found economical to order them, if such shapes are necessary. In designing, however, it is well to avoid the introduction of peculiar shapes if possible.

Plate iron is so called, in Great Britain, down to about $\frac{1}{8}$ inch in thickness (0.32 centimetre), and below this thickness is known as sheet iron, and is rolled to the Birmingham Wire Gauge (B. W. G.) instead of in fractions of an inch. In the United States, the distinction is less generally observed.

“Merchant bar iron” includes all the simple forms of a bar used in the blacksmith shop. All such iron is tested by the blacksmith’s tests.

307. Bridge Work.—In the year 1877 the Pennsylvania Railroad Company* substituted for their old bridge at Duncannon, Penn., a steel bridge of the Pratt Truss type; the specifications issued previous to the erection of the bridge were:

Elastic limit.....	45,000 lbs. per sq. in.,	3,150 kilogs. per sq. cm.
Tensile strength.....	80,000 “ “ “	5,600 “ “ “
	Elongation, 20 per cent.	

No difficulty was found in procuring this grade of material, and a factor of safety of $2\frac{3}{4}$ was allowed at the elastic limit. After the lapse of three years six of these rods had broken, and three of them were taken to Altoona for analysis, to discover if possible what modifications should be made in steel used in this kind of work.

The rods tested gave the following:

Elastic limit.....	42,000 lbs. per sq. in.,	2,940 kilogs. per sq. cm.
Tensile strength.....	85,000 “ “ “	5,950 “ “ “
	Elongation in 5 in. (12.7 cm.) 23 per cent.	

The analyses of the rods showed:

	No. 1.	No. 2.	No. 3.
Carbon326	.315	.298
Phosphorus.....	.051	.041	.049
Manganese.....	1.432	1.418	1.448
Silicon....	.052	.033	.045

* Steel for Bridges, J. W. Cloud. Trans. Am. Inst. Min. Eng. 1881.

Iron rods, having given long service in another locality, with a less factor of safety, gave

Elastic limit.....	24,000 lbs. per sq. in.,	1,680 kilogs. per sq. cm.
Tensile strength.....	50,000 " " "	3,500 " " "
Elongation in 5 in. (12.7 cm.), 25 per cent.		

The failure of these rods is attributed to the great stiffness of this steel. The modulus of elasticity being 45,000,000, was the cause of the failure; the iron just quoted having stood the test for several years without injury showed a modulus of elasticity of but 25,000,000. For reasons of this kind the requirement of a low modulus of elasticity for this branch of work is now commonly inserted in bridge specifications.

The following specifications are taken as examples of current practice in issuing specifications of iron materials for bridge work:*

The size or sectional area of the various members in tension shall be ascertained by adding the number of inches required to carry the dead load at the rate of 18,000 pounds (factor of safety, 3), the number of inches required to carry the live load at the rate of 6,750 pounds per square inch (factor of safety, 8). For metric measures this becomes the number of square centimetres required to carry the dead load at the rate of 1,260 kilogrammes plus the number of square centimetres required to carry the live load at the rate of 472.50 kilogrammes per square centimetre.

Iron floor beams and floor hangers must not be strained above 6,750 pounds per square inch (472.5 kilogrammes per square centimetre); chord bars may be strained up to the full average of the combined dead and live loads. No part less than 5 feet (1.54 metres) shall be strained in tension more than 7,000 pounds per square inch (490 kilogrammes per square centimetre).

All tensile members shall be of refined wrought iron, of

* Extracted from "Specifications for Designs for a Bridge from the City of New York crossing over Blackwell's Island." O. Chanute, J. G. Barnard, Q. A. Gillmore, Engineers.

soft fibrous texture, rolled twice from the puddle bar, with an ultimate breaking strength of at least 50,000 pounds per square inch (3,500 kilogrammes per square centimetre) in long specimens, and an elastic limit not less than 26,000 pounds per square inch (1,820 kilogrammes per square centimetre). It shall elongate at least 15 per cent. on breaking, and the elastic limit shall be understood to be the point at which the elongation produced by the strain ceases to increase in the same proportion as the strain, being the point at which the bar shows the first signs of a considerable permanent set.

For pillars having a greater length than twenty-four times the least radius of gyration, the crushing strength is to be determined by "Gordon's Formula," and in applying this strength a factor of safety is to be used, 3 for dead, and 6 for the live load, or the equivalent dead load shall be arrived at by the formula :

$$\frac{3 \text{ dead load} + 6 \text{ live load}}{3} = \text{equivalent dead load.}$$

For which the factor of safety shall be 3. From the results thus obtained 20 per cent. shall be deducted for each pin joint in a strut or post.

Cast iron shall not be used for the principal members of the trussed spans. When used it shall be proportioned by Rankine's modification of Gordon's formula, with a factor of safety of 4 for dead and 8 for live load. No cast-iron part shall be designed less than $\frac{3}{4}$ inch (1.9 centimetres) thick, nor shall it be used where it is liable to receive a transverse or tensile strain, or where there is any probability that the shape of the parts will cause imperfections in the castings, such as floating of cores, blow holes, etc.

The preceding are not now always accepted as rules for parts in compression. Robinson's formulas have been introduced into specifications, and may be expected to give good results. Burr has also proposed simple formulas, which are not given in the section on columns, but which are

likely to recommend themselves by their simple form. He takes

$$\frac{P}{S} = y \left(\frac{r}{l} \right)^x,$$

for which experiment gives $x = 0.14$, and $y = 65,000$, nearly, in British measures, or $y = 4,800$, nearly, in metric measures. The results for usual cases are very satisfactory.*

The following are *Pennsylvania Railroad Specifications* :

Wrought Iron.—All wrought iron must be tough, fibrous, uniform in quality throughout, free from flaws, blisters, and injurious cracks, and must have a workmanlike finish. It must be capable of sustaining an ultimate stress of forty-six thousand (46,000) pounds per square inch on a full section of test piece, with an elastic limit of twenty-three thousand (23,000) pounds per square inch.

All iron to be used in tension or subjected to transverse stress (except web-plates) must have a minimum stretch of fifteen per cent. under ultimate stress, measured on a length of eight inches.

All iron to be used in compression, and for web-plates, of width not exceeding twenty-four inches, must have a minimum stretch of ten per cent. under ultimate stress, measured on a length of eight inches.

All iron to be used in the tensile members of open trusses, laterals, pins, bolts, etc., must be double rolled after, and directly from, the muck bar (no scrap will be allowed), and must be capable of sustaining an ultimate stress of fifty thousand (50,000) pounds per square inch on a full section of test piece, with an elastic limit of twenty-five thousand (25,000) pounds per square inch, and a minimum stretch of twenty per cent. in length of eight inches, under ultimate stress.

When tested to the breaking point, if so required by the engineer, the links and rods must part through the body, and not through the head or pin-hole; such tests must be at the expense of the contractor when the requirements of these specifications are not complied with.

* *Trans. Am. Soc. C. E.*, Jan., 1882.

All wrought iron, if cut into testing strips one and a half inches in width, must be capable of resisting without signs of fracture, bending cold by blows of a hammer, until the ends of the strip form a right angle with each other, the inner radius of the curve of bending being not more than twice the thickness of the piece tested. The hammering must be only on the extremities of the specimens, and never where the flexion is taking place. The bending must stop when the first crack appears.

All tension tests are to be made on a standard test piece of one and a half inches in width, and from one quarter to three quarter inch in thickness, planed down on both edges equally so as to reduce the width to one inch for a length of eight inches. Whenever practicable, the two flat sides of the piece are to be left as they come from the rolls. In all other cases both sides of the test are to be planed off. In making tests the stresses are to be applied regularly, at the rate of at least one ton per square inch in fifteen seconds of time.

All plates, angles, etc., which are to be bent in the manufacture, must, in addition to the above requirements, be capable of bending sharply to a right angle, at a working test, without showing any signs of fracture.

All rivet iron must be tough and soft, and pieces of the full diameter of the rivet must be capable of bending until the sides are in close contact, without showing fracture.

Workmanship.—All workmanship must be first class; all abutting surfaces must be planed or turned, so as to insure even bearing, taking light cuts so as not to injure the end fibres of the piece, and must be protected by white lead and tallow. Pieces where abutting must be brought into close and forcible contact by the use of clamps or other approved means before being riveted together. Rivet holes must be carefully spaced and punched, and must in all cases be reamed to fit, where they do not come truly and accurately opposite, without the aid of drift pins. Rivets must completely fill the holes, and have full heads, and be countersunk when so required.

All pin holes, in pieces which are not adjustable for

length, must be accurately bored at right angles to the axis, unless otherwise shown on the drawings, and no variation of more than one sixty-fourth of an inch will be allowed in the length between centres of pin holes. Pins must be carefully turned, and no variation of more than one thirty-second of an inch will be allowed between diameter of pin and pin hole. In the case where rough bolts are permitted, a variation of one-sixteenth of an inch will be allowed between diameter of bolt and hole. Thickening washers must be used, wherever required, to make the joints snug and tight.

All iron must receive one coat of boiled linseed oil before leaving works. All inaccessible surfaces are to be painted, preferably at the bridge site during erection, with one heavy coat of red oxide of iron in pure linseed oil. All iron to be scraped clean from scale before painting.

General Conditions.—The whole of the construction to be first-class work, and in strict accordance with the drawings and these specifications. In case of sub-contractors the specifications are fully binding on them in every respect, and free access and information is to be given by them for thorough inspection of material and workmanship, and all required test pieces, etc., are to be provided as may be requested.

In all cases figures are to be taken in preference to any measurements by scale. (See Appendix.)

No alterations are to be made unless authorized by the Engineer of the Pennsylvania Railroad Company.

The following specifications are extracted from the standard bridge specifications of the *Lake Shore & Michigan Southern Railway*:

All bridges to be made entirely of wrought iron, made from the most suitable stock, and rolled twice from the puddle bar. No cast iron will be allowed to be used, except for bed plates under the ends of the bridge, and for subordinate details, such as distance and filling pieces, washers, etc.

All rolled bar, angle, channel, and tee iron shall have an ultimate strength of not less than 55,000 pounds per square inch, and all plate iron an ultimate strength of not less than

45,000 pounds per square inch, and all shall have an elastic limit not below 26,000 pounds per square inch, under which load no appreciable permanent elongation or set shall take place.

Samples for testing shall be taken from the iron intended for actual use in the bridge work, and shall be turned or planed to a uniform section of not less than 1 square inch for a length not less than 12 inches, and the elastic limit and breaking strain shall be determined on the minimum section of this turned or planed bar, and the section of the same before reduction by stretching shall be referred to in determining the strains per square inch. When tested by bending, samples 1 inch thick shall admit of being bent double under the hammer, while cold, without fracture.

Under the hereinbefore specified conditions as to permanent and moving loads, no member of the main trusses or girders shall be subjected to a greater tensile strain than 8,500 pounds per square inch, net section, after making full deductions for screw threads and rivet or bolt holes. Compression members, the lengths of which between points of rigid lateral support do not exceed twelve times the least breadth of cross section, may be subjected to strains not exceeding 7,000 pounds per square inch, and those of greater proportional lengths to strains not exceeding one-sixth of their ultimate strength, to be ascertained by Rankine's formulæ for long struts and pillars; the ultimate crushing strength of wrought iron being assumed at 40,000 pounds per square inch. The maximum strain upon floor beam hangers shall not exceed 4,500 pounds per square inch.

Tension members with screw connections may have the screw ends enlarged so that the section at the bottom of the threads shall be 10 per cent. greater than the body of the bar, in which case the full section of the body of the bar will be allowed in estimating the strain per square inch.

Eye-bars when used for tension members, either in the chords or webs of braced girders, shall be made of flat bars, and the proportions of the heads and pins shall be as described below. The heads to be elliptical in form, with the longer

axis in prolongation of the centre line of the bar. Calling the width of the body of the bar 1, the diameter of the pin shall be 0.75, the longer axis of the head 2.75, the shorter axis or width through centre of the eye 2, and the radius of the curves of the shoulders connecting the head with the body of the bar 2.

Other forms of eyes may be used, provided the proportions thereof, as compared with the body of the bar, are not less than above specified.

Especial pains must be taken in boring the pin holes, both in point of accuracy of diameter and distance between them. The difference between the diameters of the pins and the holes must not exceed one thirty-second of an inch, and the eye-bars of a set which are to be placed side by side in the structure and attached to the same pin, must be of such exactness of length that when they are laid together in their proper relative positions, all being at the same temperature, the pins to which they are to be attached can be passed through the eye of all at both ends without forcing or driving. The several members attaching to one pin shall be packed close together, so as to bring the least possible amount of bending strain on the pins. The pins to be of the best quality double-refined wrought iron, accurately turned, and the heads of the eye-bars in no case thinner than the body of the bar.

Parties submitting designs or proposals for bridges will be required to describe the method intended to be used in enlarging the ends of the screw-rods or eye-bars, whether by upsetting or welding, and in proving the quality of their work. Upsetting by pressure will generally be preferred.

In estimating the strength of tension members of riveted bridges, only the minimum section of metal measured through, and exclusive of the rivet holes, shall be taken as the available section of that member, but the rivet holes need not be deducted from the full section of members subject to compression only, in estimating the strength thereof.

All riveted work shall be machine or snap riveted, with hemispherical-shaped heads to the rivets, which shall be formed centrally upon the shanks, and the shoulders brought

down evenly and squarely upon the surface of the plate or bar. All rivets that shall be found with the heads cocked, or off the centre of shank, or loose, shall be cut out and new ones put in their places.

The rivets shall be made of the best double-refined iron, warranted to be of an ultimate strength of 60,000 pounds per square inch, and of such ductility that perfect heads can be formed at a dull red heat. Rivets shall generally be $\frac{1}{8}$ inch and the holes $\frac{7}{8}$ inch diameter, and in no one case shall the diameter of the rivet be more than $\frac{1}{8}$ inch less than the diameter of the hole. Rivet holes to be pitched not less than $2\frac{1}{2}$ diameters between centres, and in plate riveting not more than twelve times the thickness of the thinnest outside plate, and in no case more than 9 inches apart, nor shall any rivet hole be made nearer to the edge of the plate or bar than $1\frac{3}{4}$ times the diameter, nor ever nearer than $1\frac{1}{4}$ inches from the centre of the hole. When two or more thicknesses of plate are riveted together there shall always be a row of rivets not more than two inches from either edge, so that the joints between the plates may be made impervious to water.

The shearing strain on rivets shall not exceed 6,500 pounds per square inch, and the pressure upon the circumference shall not exceed 9,000 pounds per square inch of area, obtained by multiplying the diameter of the rivet by the thickness of the plate or bar bearing upon it.

The transmission of compressive strains longitudinally from one plate or bar to another, will be assumed to be wholly through the medium of rivets, no reliance being placed on abutting surfaces unless machine faced, and therefore a sufficient number of connecting rivets and joint-covered plates of proper strength must be provided for the purpose.

In plate girder bridges the webs shall be stiffened by bars of angle or tee iron, riveted vertically upon the webs at such frequent intervals as to effectually prevent any danger of buckling the web plates. No plate iron of less than $\frac{5}{16}$ inch in thickness shall be used, except for packing or filling pieces. Each pair of plate girders to be connected at the ends by transverse plates not more than six inches narrower than the

girder web plates, and stiffened at the top and bottom by angle irons. The shearing strain on the webs of plate girders shall not exceed 5,000 pounds per square inch.

Rivet holes may generally be punched, but drilled holes will be preferred, especially for all connecting joints and web-members with chords in braced girders. In all cases, joint rivet holes must be made with such accuracy that when the parts are laid together as designed to be in the structure, rivets of the required diameter can be passed through all of the holes without reaming or forcing with drift-pins. No inaccurate or otherwise defective work will under any circumstances be accepted in the connecting joints of riveted work.

Bridges of more than fifty feet span shall have turned wrought-iron rollers, running between surfaced cast-iron plates, at one end, to allow for expansion and contraction. The weight on these rollers shall not exceed 300 pounds per lineal inch for each inch of diameter of roller. Bridges of fifty feet span, or less, shall have bearings at one end, on friction plates of cast iron, both surfaces in contact being planed.

All iron work shall be painted, in the shop, with one good coat of iron-ore paint and linseed oil, which shall be applied in riveted work before the parts are riveted together, and all cavities that will be inaccessible after erection shall receive two coats.

308. General Observations.—In testing “eye-bars” for the tension members (lower chords) of iron bridges, it is often customary to subject the bar to a tension of 15,000 pounds per square inch (1,045 kilogrammes per square centimetre), and then to pass the pins through both eyes of all the bars in a pile simultaneously; any bar which has taken so large a set as to prevent the passing of the pin is rejected.

In tests of rails the drop test is now almost universally practised. The weight, span between supports, and depth of fall are very variable. Rails of 50 to 60 pounds to the yard are usually placed on supports 3 feet apart and loaded with 10 to 15 tons on the middle, and no set is expected to take place after a half-hour; or, a weight of one ton falling 12 or 15 feet is adopted. Rails of 75 to 85 pounds weight per

yard are loaded with $2\frac{1}{2}$ to $3\frac{1}{2}$ tons, or a drop of one ton falling 15 to 20 feet is used, the deflection under the static load not to exceed $\frac{3}{8}$ inch or $2\frac{1}{2}$ inches under the drop.

Specifications usually demand a tenacity for rolled irons of at least 50,000 pounds per square inch (3,515 kilogrammes per square centimetre), and sometimes of 60,000 (4,218 kilogrammes). The prescribed "elastic limit" is from one-third to one-half the tenacity. The elongation is expected to be, ordinarily, 15 per cent., and sometimes 25. A fair quality stretches 12 per cent., and should have at least the lower tenacity above specified. High tenacity often accompanies low ductility; great elongation goes with low tenacity. Only when both qualities are low can the iron be condemned as bad.

For many purposes the blacksmith's tests are the best gauge of value, and any iron that will make a good horse-shoe, or a horseshoe nail, may be accepted as good.

Common tests of special sections are

	TENSION.		REDUCTION OF SECTION.
	Lbs. per sq. in.	Kilogs. per sq. cm.	Per cent.
For <i>bar iron</i>	52,000	3,656	20
L-iron	50,000	3,515	15
sheet, lengthwise..	45,000	3,164	10
" crosswise. . .	40,000	2,812	5

Defects are often detected by observation or simple inspection. Lamination, seams, and surface defects are thus detected.

Specifications often demand a tenacity in cast iron of at least 20,000 pounds per square inch (1,406 kilogrammes per square centimetre) in the United States, and twenty per cent. less in Europe. A common figure for tests, as a minimum, is 12,000 pounds per square inch (844 kilogrammes per square centimetre), and an observable elastic limit at half this load. The working load is often fixed at 5,000 pounds (352 kilogrammes). A bar $3\frac{1}{2}$ feet long (1.07 metres), 2 inches (5.08 centimetres) deep, and 1 inch (2.54 centimetres) thick, on supports 3 feet (0.9 metre) apart is usually ex-

pected to carry at least 3,000 pounds (1,364 kilogrammes) at the middle; a load one-third greater is often borne.

The composition of the metal is often prescribed in the specifications. Thus rails are sometimes required to contain: carbon 0.3–0.45 per cent.; silicon, phosphorus, and sulphur, each less than 0.06 per cent.

A good, soft, wrought iron should, when broken slowly, exhibit a silky, fibrous texture of dull, leaden, uniform color, medium grain, free from bright, crystal-like surfaces or points, and from sharply marked areas of friable iron. It works easily under the hammer, drawing down without cracking, welding easily, and shows no cracks on the edges.

Hard iron, of steely character, has a finer grain and is often hot-short and difficult to weld, cracking on the edges when drawn under the hammer. Cold-short iron has a coarse grain, a bright, granular or crystalline fracture, and, if not also hot-short, welds better than neutral iron.

Good steel should exhibit a uniform fracture, gray lustre if soft, dull silver-white when hard, and should be free from cracks, lines of differing quality, or shining points. It should draw down under the hammer readily at a low heat, even when of hardest grade. Tool-steel should draw down to a sharp point, and, when hardened in cold water, should scratch glass. A blacksmith's test is to place a bit thus hardened on a handy piece of cast iron on the anvil and strike it a sharp blow; if good, it will be driven into the cast iron without crushing.

The superior strength of the mild steels, and their high ductility, render them more suitable than iron for structures of all kinds; their resistance to abrasion and wear makes them particularly valuable for rails, and these good qualities combine to make them the best materials for use in machine construction. When first introduced, the endeavor was made to secure high tenacity, and it was a long time before it was found that the lack of ductility which accompanies great strength in steels, is a fatal defect for such constructions. It finally became a familiar fact to engineers that their greatest excellence was to be found in their superior homogeneousness and ductility when made moderately low in carbon, and specifications

now usually forbid the acceptance of such steels of a tenacity exceeding that of iron by more than about 50 per cent. Their cost has, during late years, been rapidly reduced, and it now competes in price with the finer grades of iron.

It usually retains some of the peculiar defects of the older steels, *e. g.*, it cannot be as easily welded as iron, in consequence, probably, of the absence of silicon and the presence of manganese. A crack once started extends further and more rapidly than in wrought iron. On the other hand, its higher proportion of elastic limit to tenacity is a decided merit of steel when competing with iron.

The reduction of weight permitted in consequence of the use of the stronger material in bridges, is a very important advantage, and allows the construction of greater spans. The same advantage is felt in the increase of the cargo-carrying capacity of vessels built of steel as compared with iron. Steam boilers are reduced in weight by the use of steel, and are also more efficient in consequence of the greater conductivity of the metal, as well as the reduced thickness of the sheets; their smooth surfaces afford a less adherent area for the attachment of scale deposits. As all steels of this character are first cast into heavy ingots, and then rolled or hammered into shape, a part of their superior quality comes of this treatment, as they are worked, in the process, more than iron usually is. Steel is displacing the finer grades of iron in all directions.

309. Examinations of the Structure of iron or steel may be made by the simple and ingenious method of etching the surface and studying the texture of the metal, as thus revealed, by the eye, unaided by the microscope.

In this operation, the surface to be examined is planed up, and smoothly finished over as great an area as it is proposed to examine.

Dilute sulphuric or hydrochloric acid is washed over it, or if the piece is small the finished surface is immersed in the acid for some minutes, the time being determined by the degree of dilution of the acid and by the character of the metal.

The acid dissolves the iron or the steel at a rate which is determined by its purity, and by the degree of its carburization; the purer iron is first attacked, then that containing more carbon, and the cinder is left undissolved, standing above the general surface of the metal. Every peculiarity of composition or of structure is thus revealed plainly to the eye, or by the microscope.



FIG. 141.—LOCOMOTIVE AXLE—
"SPECIAL" IRON.

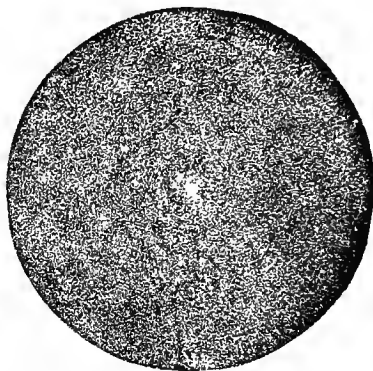

FIG. 142.—LOCOMOTIVE AXLE—
STEEL.

These etched surfaces may often be made so perfectly even, and yet so plainly characteristic of the quality of iron or steel, that they may be used to print from as from an engraved block, or etched copper-plate, and have been so used.

When an iron surface, parallel to the line of direction of rolling of plates, or of drawing down of pieces made or shaped under the hammer, is thus etched, it exhibits plainly the lines of "fibre" produced by the drawing out of the cinder originally present in the puddle-ball, and reveals any defective weld or the presence of any mass of foreign material. When a cross section is made, as in the cases exhibited in the preceding figures, the character of the piling is shown, and also that of the workmanship. In these examples, which are reduced to one-half the size of the originals, Figure 141 is a section so etched of an iron locomotive axle, and Fig. 142 of a

steel axle of similar size and design. The beautiful homogeneousness of good steel is exhibited by the almost perfect uniformity of the color and texture of the surface; while the irregularity both of color and structure of the other illustration reveals plainly the reasons for the variable wearing quality and the inevitable uncertainty of strength which must always attend the use of forged iron, and especially when made of "scrap." It is evidently hopeless to secure perfect uniformity of structure, texture and strength, or even to obtain soundness, where such a great number of welds are to be made, and where so much impure and foreign material is distributed, hap-hazard, through the mass.

The use of the microscope, as described in the last chapter, will probably prove of value in this connection.

310. Standard of Tests of Iron and Steel.—The most complete specifications of standard tests for iron and steel are probably those adopted by the Society of German Ironmasters, at Dusseldorf, on May 28–29th, 1881,* and those of the Committee of American Mechanical Engineers.†

The classification of tests adopted are (see Appendix):

A.—TESTS WITH UNDIVIDED OBJECTS.

- | | | |
|----------------------------|---|--|
| 1. <i>Cold Tests</i> | { | 1. External inspection.
2. Hammering.
3. Falling weight.
4. Direct loading. |
| 2. <i>Hot Tests</i> | { | 1. Bending.
2. Punching.
3. Forging.
4. Welding. |

B.—TESTS WITH SEPARATED PIECES.

- | | | | |
|----------------------------|---|--|---------------------------------|
| 1. <i>Cold Tests</i> | { | 1. Bending.
2. Punching.
3. Breaking.
4. Tensile. | 2. <i>Hot Tests</i> ..As above. |
|----------------------------|---|--|---------------------------------|

* Stahl und Eisen, Vol. I., Part 1; Abstracts of Papers in Foreign Transactions and Periodicals, Inst. C. E., Vol. LXVII., p. 66.

† Trans. A. S. M. E., 1890.

311. The Standards for the different Classes of Material are :

HOMOGENEOUS METAL (*Steel*) RAILS.

TESTS WITH UNDIVIDED MATERIAL.

(a.) *Inspection*.—Variations allowable in linear dimensions ± 0.12 inch (3 millimetres) in length, $\pm 0.02''$ ($\frac{1}{2}$ millimetre) in height, and $\pm 0.04''$ (1 millimetre) in breadth of flange.

(b.) *Falling Weight*.—Test rails are neither to be bored or punched, and the ends should not project more than 1 foot 6 inches, or $\frac{1}{2}$ metre, beyond the bearings. The weight is 1,323 pounds (600 kilogrammes), falling from the following heights :

1. Weighing above 20 pounds per foot (30 kilogrammes per metre) and 3.2 inches (130 millimetres) high, 16.4 feet (5 metres).
2. Weighing above 18.4 to 20.1 pounds per foot ($27\frac{1}{2}$ to 30 kilogrammes per metre), and 4.8 inches (120 millimetres) high, 11 feet ($3\frac{1}{4}$ metres).
3. Weighing above 15.5 to 18 pounds per foot (23 to 27 kilogrammes per metre), and 4.4 inches (110 millimetres) high, 8.3 feet (2.5 metres).
4. Weighing above 13.4 to 16.1 pounds per foot (20 to 24 kilogrammes per metre), and 4.0 inches (100 millimetres) high, 6.6 feet (2 metres).

The test piece, 3.28 feet (1 metre) long between the points of support, in each case to receive two blows without fracture.

(c.) *Loading Test*.—To the different sections and weights given above, the weights to be supported without producing more than 0.02 inch ($\frac{1}{2}$ millimetre) permanent deflection, are :

- | | | | | | |
|----|--------|---------|----|--------|--------------|
| 1. | 38,500 | pounds, | or | 17,500 | kilogrammes. |
| 2. | 29,700 | " | " | 13,500 | " |
| 3. | 25,300 | " | " | 11,500 | " |
| 4. | 22,000 | " | " | 10,000 | " |

(d.) *Bending Test*.—A length of rail 3.28 feet (1 metre) long between the points of support, should bend 0.2 inch (50 millimetres) over both head and foot without fracture.

TESTS WITH PREPARED TEST PIECES.

(a.) *Tensile Test.*—Under the assumption that either reduction of area or elongation, but not both, will be used in judging the material, the following tests are recommended:

Bars 7.9 inch (20 centimetres) long and 0.79 inch (20 millimetres) diameter shall bear a minimum load of 71,000 pounds per square inch (50 kilogrammes per square millimetre),* with a reduction of area of 20 per cent., or an elongation of 12 per cent.

Further conditions set by this Commission are:

(1.) As limits in toleration in weight 3 per cent. above and 2 per cent. below the normal weight, and an excess weight above 2 per cent. should be paid for.

(2.) As regards maximum length, 30 feet (9 metres), beyond which very few rolling mills are capable of working, and the risk of damage in transport is greatly increased.

(3.) About 5 per cent. of the rails of shorter length than the standard are to be received.

(4.) The guarantee for rails is fixed at five years, commencing on the 1st of January next following the date of delivery.

(5.) Rails worn out in regular traffic not to be replaced by the guarantor. The guarantee on rails replaced to terminate at the same date as that on the original contract.

The number of rails reserved for testing not to exceed $\frac{1}{2}$ per cent. of the whole amount.

STEEL TIRES.

(a.) *Falling Weight Test.*—To endure three blows of a weight of 1,320 pounds (600 kilogrammes) falling 16.4 feet (5 metres) without fracture. Tensile test with pieces 10 inches (25 centimetres) and 0.79 inch (20 millimetres) thick.

(1.) *Locomotive Tires.*—Tensile strength, 78,000 pounds per square inch (55 kilogrammes per millimetre); contraction, 25 per cent.; elongation, 12 per cent.

(2.) *Tender and Wagon Tires.*—Tensile strength, 64,000 pounds (45 kilogrammes); contraction, 35 per cent.; elon-

* This figure is 10 per cent. higher than is considered best by many engineers in this country.

gation, 18 per cent. The guarantee of two years not to be extended to tires subjected to the action of brakes, or to those worn out in regular traffic. The toleration in dimensions to be 0.012 inch per foot (1 millimetre per metre) of diameter. The number of tested pieces not to exceed $\frac{1}{2}$ per cent. of the whole.

STEEL AXLES.

(a.) *Falling Weight Test.*—To support without fracture, upon a length 5 feet (1.5 metres) between bearings, six blows from a weight of 1,320 pounds (600 kilogrammes) as follows, the point of impact being changed after each blow: Two of 13.1 feet (4 metres) drop; two of 14.7 feet ($4\frac{1}{2}$ metres); one of 16.4 feet (5 metres); and one of 19.7 feet (6 metres).

(b.) *Tensile Test.*—Maximum strength, 64,000 pounds per square inch (45 kilogrammes per square millimetre); contraction, 28 per cent.; extension, 15 per cent. Guarantee four years against failure through defective material or manufacture. Number of tests not to exceed $\frac{1}{2}$ per cent. of total.

STEEL SLEEPERS.

(a.) *Cold Bending Test.*—When flattened by moderately heavy blows of a steam hammer, to stand bending round a radius of 2.95 inches (7.5 centimetres) into a loop, without fracture. This test is only to be used when the form of sleeper permits.

(b.) *Tensile Test.*—As for axles, with 30 per cent. contraction or 15 per cent. elongation.

Permissible variation in weight, 3 per cent. above and 2 per cent. below the standard; and in length, for cross sleepers, 0.57 inch (15 millimetres); for longitudinal sleepers the same as for rails. Number of tests not to exceed $\frac{1}{4}$ per cent. of the whole. Period of guarantee, two years.

STEEL FISH-JOINT AND BEARING PLATES.

The tensile strength to be the same as for rails, but, having regard to the great variety in the form of these articles in use, the general application of other tests does not seem to be desirable.

312. Steel Constructive Material.—As sufficient experience does not seem to be had in steel constructive material, it was deemed inadvisable to recommend any special series of tests. A tenacity of 64,000 to 71,000 pounds per square inch (45 to 50 kilogrammes per square millimetre), and an elongation of 0.15 to 0.20 is expected.

Steel Plates.—(1.) *Ship Plate.*—The tests recommended are those in use in the German navy, 56,892 to 71,000 pounds per square inch (40 to 50 kilogrammes per square millimetre). Annealed plates should bend cold upon a radius equal to the thickness, through 180°, without fracture. Plates 10 inches (260 millimetres) long and 1.58 inch (40 millimetres) broad, raised to a cherry heat and cooled in water to 81° Fahr. (28 Cent.), to bend round a radius of 1½ thickness without fracture.

(2.) *Boiler Plates.*—Tensile strength of 54,000 to 68,000 pounds per square inch (38 to 47 kilogrammes per square millimetre), with an extension of 25 to 18 per cent. Plates, when soft, to bend cold through an angle of 180° upon a radius of half the thickness. When hardened, to satisfy the test given for ship plates.

The above tests are applicable to plates at least 0.2 inch (5 millimetres) thick, the testing of thinner ones not being considered necessary.

313. Welded Material.—Bar Iron.—(1.) Rivet (best best) iron.—For this quality a tensile strength of 54,000 pounds per square inch (38 kilogrammes per square millimetre), with an extension of 15 per cent., is required.

(a.) *Cold Bending Test.*—Pieces cut from flat bars, from 1.2 to 2 inches (30 to 50 millimetres) broad and not more than 0.6 inch (16 millimetres) thick, and round bars up to 1.2 inch (30 millimetres) in diameter, should stand bending into a loop whose inside diameter is equal to the thickness of the bar.

(b.) *Hot Test.*—When heated, the test piece must bear doubling, and a piece of round iron two diameters long must bear reduction to one third its length without cracking.

(2.) Horse-shoe, bolt, or (best) iron.—Tensile strength, 52,000

pounds per square inch (36 kilogrammes per square millimetre), with an extension of 12 per cent.

(a.) *Cold Bending Test*.—Flat section not more than 0.6 inch (16 millimetres) thick, square and round up to 1.2 inch (30 millimetres) diameter, to bend, without cracking, into a loop, whose internal diameter is twice the thickness of the iron.

(b.) *Hot Test*.—The test piece of the dimensions previously given must bear bending into a loop whose inner diameter is equal to the thickness of the iron.

The above values for tensile strength and extension can only be held to apply to manufactured objects whose thicknesses are not greater than those given under the cold bending tests. If, therefore, it is desired to test thicker objects, the test pieces must be reduced to the proper size by forging or rolling. The standard length for test pieces is fixed at 7.8 inch (20 centimetres).

(3.) *Ordinary Bar Iron*.—The Commission does not consider it possible or necessary to introduce tests for this class of iron, as the differences between the makes in the iron-making districts are dependent upon the local material employed, and cannot be eliminated.

314. Railway Material. — (1.) (2.) (3.)—Sleepers, Fish Plates, and Bearing Pieces.—The toleration in weight and dimensions to be the same as that given for steel sleepers. Up to the present time railway managers have not specified any particular quality other than fibrous iron generally. Probably a tensile strength of 48,358 pounds per square inch (34 kilogrammes per square millimetre), and an extension of 10 per cent., will be sufficient.

Should a cold bending test be required, it is proposed that test pieces 1.2 to 2 inches (30 to 50 millimetres) broad, with rounded edges, should stand bending upon a radius of 0.5 inch (13 millimetres) as follows:

Thickness	0.3	to 0.43	inch (8 to 11 millimetres),	50°.
Thickness	0.47	to 0.6	inch (12 to 15 millimetres),	35°.
Thickness	0.064	to 0.08	inch (16 to 20 millimetres),	25°.
Thickness	0.83	to 1	inch (21 to 25 millimetres),	15°.

Hot tests of these articles are not considered necessary, as they are never subjected to heating in use.

As experience shows that the quality of the material is not affected by punching or notching when cold, this should be permitted. The permissible variation in length to be ± 0.12 inch (3 millimetres), and in weight 3 per cent.

It must be remembered that these articles cannot be sawn hot, as is sometimes required, but must be cut cold with a shearing machine.

(4). Small Iron Material: Bolts, Spikes, etc.—Usually a high quality of fibrous iron is specified for these objects. A tensile strength of 50,000 pounds per square inch (35 kilogrammes per square millimetre); with an elongation of 42 per cent., should be sufficient. The cold and hot bending tests should be the same as for best iron.

315. Plates.—The Commission considers it sufficient to lay down bending and tensile tests for the three best qualities of plates, leaving it to the consumer and producer to distinguish these by particular names.

It is to be remarked that many of the names hitherto used are no longer applicable; for instance, so-called charcoal plates are not always made from charcoal iron, etc. A generally recognized classification, which should as far as possible express the quality, is much to be desired.

The following are the tests recommended:

WITH ENTIRE OBJECTS.

Inspection.—Each plate, when examined on both sides, is to be free from blisters, cracks, and other marks of defective rolling; surfaces to be smooth and uniform.

In dimensions a variation of ± 0.4 inch (10 millimetres) in length and breadth. The weight to correspond to that form by calculation within ± 5 per cent. in single plates, and ± 3 per cent. in larger quantities.

WITH PREPARED TEST PIECES.

(a.) *Bending Tests.*—The hot bending test to be round a

square edge, the cold ones round a cylinder 1 inch (26 millimetres) in diameter.

The angles through which the plates must bend red hot, are

	No. III.	No. II.	No. I.
With the grain	110°	150°	180°
Across the grain.....	80	120	180

COLD BENDING TESTS.

THICKNESS.		No. III.		No. II.		No. I.	
Inch.	Millimetres.	Longitudinal.	Transverse.	Longitudinal.	Transverse.	Longitudinal.	Transverse.
0.24 to 0.028	6 to 7	50°	30°	80°	50°	110°	90°
0.32 " 0.036	8 " 9	45	25	70	40	100	80
0.4 " 0.044	10 " 11	40	20	60	35	90	70
0.48 " 0.52	12 " 13	35	15	50	30	80	60
0.56 " 0.06	14 " 15	30	12	40	25	75	50
0.64 " 0.068	16 " 17	25	10	35	20	70	40
0.72 " 0.076	18 " 19	20	8	30	15	65	35
0.80 " 0.084	20 " 21	15	5	25	10	60	30

The test piece is to be considered broken when a visible fracture appears in the iron.

(b.) *Tensile Tests.*—The cuttings removed from the dome, man-hole, or fire-tube plates to be used where possible. Fire-box and certain shell-plates to be ordered 2 inches (50 millimetres) larger than the dimensions required, to allow the test pieces to be cut from them. The choice of length of the rectangular test piece between 6 and 8 inches (15 to 20 centimetres), and of the section between 0.465 and 0.93

square inch (300 to 600 square millimetres) to be left to the maker.

The tensile strength required is exhibited by the following table :

TENSILE STRENGTH OF PLATE IRON.

	No. III.				No. II.				No. I.			
	Longitudi- nal.		Trans- verse.		Longitudi- nal.		Trans- verse.		Longitudi- nal.		Trans- verse.	
	Lbs. p. sq.in.	Kgs. p. sq.mm.	Lbs. p. sq.in.	Kgs. p. sq.mm.	Lbs. p. sq.in.	Kgs. p. sq.mm.	Lbs. p. sq.in.	Kgs. p. sq.mm.	Lbs. p. sq.in.	Kgs. p. sq.mm.	Lbs. p. sq.in.	Kgs. p. sq.mm.
Tensile strength.	46,935	33	42,669	30	49,780	35	46,935	33	51,202	36	48,358	34
Extension	7 %		5 %		12 %		8 %		18 %		11 %	

The extension is to be measured after fracture. The metric numbers given for strength and extensibility may vary by one, but the sum of both must be equal to that of the Table.

The values given above are those adopted by the German Steam-boiler Inspection Commission, at their meeting at Wurzburg, February 10th, 1881.

316. Construction Iron.—By this term is meant the quality of rolled bar iron used in construction of bridges and other large works.

TESTS WITH UNDIVIDED OBJECTS.

(1). *Inspection.*—The iron must be properly rolled, with smooth, even surfaces, and free from cracks and cinder patches and other surface defects.

(2). *Fracture.*—A flat bar, when nicked with a chisel and bent, must show a mainly fibrous structure, except in the case of bolt or rivet iron, where a fine-grained fracture may be required.

All further tests with full-sized objects are to be avoided, either as being inapplicable, or because the information required may more readily be obtained by working on prepared test pieces.

The hot bending test sometimes specified for flat and angle iron bars, of requiring the full-sized bar to bend hot through a certain angle, is uncertain, as the result depends mainly on the skill of the operative making it. A good smith may apply it successfully to an inferior quality of material, while an unskilled one may fail with a better class of iron. The existence of red-shortness, which this is intended to detect, may be more readily determined by the hot test on prepared pieces.

TESTS WITH SEPARATED PIECES.

According to its uses, iron for constructive purposes may be divided into the following four classes (I. to IV.), each corresponding to a particular requirement, or a particular method of manufacture.

I. For angle and flat bars and plates subjected to strain in one direction, including girders, tension-rods, compression struts, etc.

(1.) *Cold-bending Test*.—A strip, 1.2 to 2 inches (30 to 50 millimetres) wide, must bend, without fracture, round a cylindrical surface of 0.52 inch (13 millimetres) radius, through an angle varying with the thickness of the plate. These angles are the same as those already given under Fish-plates. This method of bending is to be preferred to the custom of bending into a large loop of large radius, more generally practised, as it may be applied mechanically in a more uniform way than can be done when the result depends in part on the skill of the operator.

(2.) *Tensile Test*.—Longitudinal breaking strain, 51,000 pounds per square inch (36 kilogrammes per square millimetre), extension, 12 per cent.; the test pieces to be from 1.2 to 2 inches (3 to 5 centimetres) long, and the extension to be measured on 0.8 inch (2 centimetres).

These figures apply only to bars whose thickness is less than 0.6 inch (16 millimetres). Heavier bars should, as a rule, be avoided for such uses. When it is required to test the material of thicker bars, the piece must be reduced to the standard dimensions by forging and rolling.

(3.) *Hot Bending Test*.—Strips of the same dimensions as in the cold bending test should, when similarly treated at a cherry-red heat, bend through the following angles according to thickness. Up to 1 inch (25 millimetres) 120° ; above 1 inch (25 millimetres) 90° .

(4.) *Forge Test*.—A strip of flat or angle bar or plate, cut cold and heated to redness, must extend under the hammer to one and a half times its original breadth without showing signs of separation in the iron. The radius of the hammer-pene to be 0.6 inch (15 millimetres).

II. Plates that are subjected to strains in different directions, or mainly to bending strains, including connecting plates, corner plates, gussets, etc.

(1.) *Cold Bending Test* (with the fibre the same as for Class I).—Across the fibre the angles are according to the thickness: 0.32 to 0.43 inch (8 to 11 millimetres), 20° ; 0.47 to 0.6 inch (12 to 15 millimetres), 15° ; 0.64 to 0.8 inch (16 to 20 millimetres), 10° ; 0.84 to 1 inch (21 to 25 millimetres), 5° .

(2.) *Tensile Test*.—When the plates are approximately square the breaking strain is :

Longitudinal, 49,870 pounds per square inch (35 kilogrammes per square millimetre); extension, 10 per cent.

Transverse, 42,669 pounds per square inch (30 kilogrammes per square millimetre); extension, 4 per cent.

As the plates are used merely as connecting pieces, the tensile strength may be taken as 1,422 pounds per square inch (1 kilogramme per square millimetre), lower than Class I., as the constructor has to work mainly by the lower strength in the transverse direction. For the same reason the extensibility may be reduced 12 per cent. to 10 per cent.

When the length of the plate is much greater than the breadth the values are :

Longitudinal, 49,780 pounds (35 kilogrammes); extension, 10 per cent.

Transverse, 39,824 pounds (28 kilogrammes); extension, 3 per cent.

These plates are mainly applied to the webs of girders.

and of cross and longitudinal bearers, whose length is at least eight times their breadth, for which purposes the values just given are sufficient.

(3.) *Hot Bending Test*.—Same as Class I.

(4.) *Forge Test*.—Same as Class I.

317. Girder Iron and Flooring Plates.—This includes I, T, C, L bars, sash bars, etc.; also, buckled, corrugated, checkered, and similar plates.

Tensile test for girders :

Longitudinal, 49,780 pounds per square inch (35 kilogrammes per square millimetre); extension, 12 per cent.

In this class of iron, no great transverse cohesion can be expected, as the pressure in rolling in such directions is but small. It is customary to use C iron for connecting pieces, on account of its convenient shape, and in such cases a transverse strength similar to that in Class II. should be required. This, however, cannot be obtained under the ordinary conditions of manufacture, and it is therefore preferable in such cases to use a combination of flats and angles rather than a solid section.

For covering and flooring plates tensile tests are not necessary, the quality of the material being sufficiently evinced in the manufacture. On account of their large amount of surface, their substance is more likely to suffer from rust than from loading.

Rivet and bolt iron subjected to shearing strains :

Cold Test.—To bend cold under the hammer to a loop equal to the diameter of the bar without cracking. Tensile strength, 54,000 pounds (38 kilogrammes); extension, 15 per cent.

Hot Test.—A piece two diameters long when heated to a proper working temperature (that of hot riveting), to bear a reduction under the hammer to one-third its length without cracking at the edges.

318. British Tests.—The English "Admiralty" issue the following requirements, other than the ordinary tensile tests, for test of irons :

Samples of B. B. iron 1 inch (2.54 centimetres) thick are to bend cold, without fracture, to an angle of 15° with the grain, and 5° across the grain, ½ inch (1.27 centimetres) plates, 35° and 15° respectively, ⅜ inch (0.48 centimetre) and under, must bend 90° and 40°. When hot, plates 1 inch (2.54 centimetres) and under, must bend 125° with, and 90° across the grain.

For B. iron, the requirements are :

THICKNESS.		ANGLE.	
Inches.	Centimetres.	With the grain.	Across the grain.
1	2.54	10°	5°
½	1.27	30°	10°
⅜	0.48 and under,	75°	30°

Test pieces to be 4 feet (1.22 metres) long with the grain and full width of plate across the grain.

The plate should be bent from 3 to 6 inches (7.62 to 15.24 centimetres) from the edge.

The requirements for angle and beam irons are similar to those of the German Ironmasters' Association already given.

With bolt and rivet iron the tests are also the same as the German Association, but an additional test of one ton (1,016 kilogrammes) falling 30 feet (9.1 metres) in such a way as to cause elongation of the bolt is required. The number of blows sustained, the appearance and location of fracture are taken as criterions of the material.

319. The Admiralty and Lloyd's Tests for Steel are the following when selecting mild-steel ship plates :

Admiralty.—Tenacity from 26 to 30 tons per square inch (4,100 to 4,700 kilogrammes per square centimetre). Extension at least 20 per cent. in a length of 8 inches (19.3 centimetres).

Longitudinal stress, planed down, 1½ inches (3.8 centimetres) wide, heated to low cherry-red, cooled in water 82° Fahr. (28° Cent.), must bend, in the press, to a curve of radius equal to one and a half times the thickness.

Plates must be free from lamination and injurious surface defects.

One plate in every fifty in any invoice is to be tested.

Test pieces to be 8 inches (20.32 centimetres) long, or more, and parallel.

Weight is estimated at forty pounds per square foot for one inch thick, with a variation allowable of 5 per cent. (lighter weight only), on plates of half inch thick or thicker.

The same specifications apply to bulb, bar and angle steel.

Lloyd's rules allow for one ton higher tenacity and one half the bend specified by the Admiralty. Masts and yards are to be made of iron having a tenacity of 20 tons per square inch (3,150 kilogrammes per square centimetre).

In working, all plates and bars are to be bent cold when possible, and heating only resorted to when unavoidable. All parts that have been heated must be annealed as a whole, if possible, and if not, a little at a time. When necessary, long pieces may be made up of shorter ones with butted joints shifted and strapped securely. No pieces failing in the working can be used, but samples must be cut from them and forwarded to the Admiralty for examination. Work must be finished above a black heat. Hammering is objected to, and the hydraulic press used for bending when practicable.

320. American Specifications.—An American railroad makes the following specifications for materials supplied to the repair shops (see Appendix):

Specifications for Common Bar Iron.—*Grain.*—To be uniform and fibrous, rather than granular in texture. *Workmanship.*—All bars to be smoothly rolled and to be accurately gauged to size ordered. *Tensile Strength.*—To average 55,000 pounds per square inch (3,867 kilogrammes per square centimetre), and no iron to be received less than 50,000 pounds to

FIG. 143.



square inch (3,515 kilogrammes per square centimetre). *Working Test.*—A three-quarter inch bar bent double, cold, to show no fracture; the same bar, heated, to be bent and also to be drawn to a point showing no tendency to "red-shortness." (See Appendix.)

Specifications for Stay-bolt Iron.—*Grain.*—To be uniform and of a fibrous nature. Iron to be soft and easily

worked. *Tensile Strength*.—To be 60,000 pounds to the square inch (4,218 kilogrammes per square centimetre). *Working Test*.—A bar three-quarter inch diameter to be bent cold, showing no flaw; a piece of same diameter, having thread cut on it, may show opening when bent double, cold, but such opening should not extend more than one-eighth of an inch in depth; when tapped into the boiler the metal should not become brittle when hammered down to form a head.

321. Cooper Lines.—In testing large parts of structures of such proportions as permit considerable change of shape before rupture, “eye-bars” for bridges, for example, the lines of greatest flow are often marked by changes in the surface of the metal, or in the superficial coating of oxide always covering them. These changes produce lines following the course of maximum strains, which are thus easily traced. The whole surface of the head of an eye-bar is often, after test, found covered with a net-work of such lines, sometimes resembling the Chladni figures, produced by sound-vibrations of a sand-covered plate, and sometimes the lines of magnetic force developed by the action of a magnet on iron filings scattered over a paper held above its poles. These lines were first studied by Theodore Cooper, C. E., and are therefore often called “Cooper lines.” They give useful indications of the distribution of strain in metal, and may thus lead to a knowledge of the best proportions for a design, as well as indicate to the inspector the lines of weakness of the piece.

322. The Duties of the Inspector are such as demand the utmost care, considerable skill, and a large amount of experience, together with a good judgment and absolute conscientiousness. The inspector must also be a man of sufficient strength of character to do his duty by his employers, whatever influences may be brought to bear upon him to induce him to pass work or material which does not fully comply with the specification. He is expected to examine all material with a view to the determination, both of its full compliance with the terms of the specification and contract, and of its general fitness for the work.

The first step in inspection is a careful measurement of the piece offered for examination, and a comparison with the drawing, model, pattern, or template, to ascertain if it is made exactly to size.

Exact workmanship is often secured by a system of standard gauges. This is especially the case where machines are made in large numbers. The modern method of manufacturing machinery for the market compels the adaptation of special tools to the making of special parts of the machines, and the appropriation of a certain portion of the establishment to the production of each of these pieces, while the assembling of the parts to make the complete machine takes place in a room set apart for that purpose. But this plan makes it necessary that every individual piece of any one kind shall fit every individual piece of a certain other kind without expenditure of time and labor in adapting each to the other.

This requirement, in turn, makes it necessary that every piece, and every face and angle, and every hole and every pin in every piece, shall be made precisely of this standard size, without comparison with the part with which it is to be paired; and this last condition compels the construction of gauges giving the exact size to which the workman or the machine must bring each dimension.

In order that this system, which has introduced very great economy into the gun manufacture, into sewing machine construction, and into many other branches of mechanical business, may become more general, and also in order to secure that very important result, a universal standard for gauges and for general measurement, an acknowledged standard for the whole country, and for the whole world, if possible, one that shall be an exact representation of the legal standard measure, and one which shall be known and acknowledged as such, and as exactly such as is needed, has been proposed by the American Society of Mechanical Engineers.* The inspector is, by the use of such gauges, enabled readily to determine the accuracy of workmanship of parts inspected.

* Transactions, 1882.

The size being found right, the piece is next examined to determine the quality of the material of which it is composed. This can be best seen in finished work, on which every cinder-streak, or other surface defect of weld-iron or steel can be seen. Defective welds, lamination, or variable quality, is looked for in these metals, and "cold-shuts" and shrinkage cracks in cast iron. A blow with a hammer will often indicate the soundness or unsoundness of the metal where superficial examination gives no certain knowledge. Boiler plate is sometimes tested by suspending it by one corner and tapping it with the hammer; any deficiency of resonance indicates defects. Where these defects appear on the surface, the sheet may be supported horizontally and a little water poured on it; tapping the sheet sharply with the hammer causes the water to penetrate between the laminæ, and sometimes leads to the discovery of extended surfaces of defective welds.

The methods of testing full-sized parts and the standard test pieces are substantially the same, and have been fully described in Chapter IX. When, as is often the case, the contract directs that parts shall be tested within the elastic limit, and the modulus of elasticity thus determined, the piece is often subjected to the blow of a heavy hammer while carrying the maximum load. In determining the value of materials of construction, it is usually more necessary to determine the position of the limit of elasticity and the behavior of the metal within that limit than to ascertain ultimate strength, or, except, perhaps, for machinery, even the resilience. It is becoming well recognized by engineers, that it should be possible to test every piece of material which goes into an important structure, and to then use it with confidence that it has been absolutely proven to be capable of carrying its load with a sufficient and known margin of safety. It has quite recently become a common practice to test bridge rods to a limit of strain determined by specification, and to compel their rejection when found to take a considerable permanent set under that strain. The method of testing by torsion, as practised by the Author, allows of this

practice with perfect safety. The limit of elasticity occurs within the first two or three degrees in the standard test piece (Art. 221), and the specimen may be twisted many times as far without even reaching its maximum of resistance, and much farther still before actual fracture commences. It is perfectly safe to test, for example, a bridge rod up to the elastic limit, and then to place the rod in the structure, with a certainty that its capacity for bearing strain without injury has been determined, and that formerly existing internal strain has been relieved.

The inspector will find that the plotting of his tests, and the production of the ' strain diagram," either in this manner, or preferably by an automatic registering testing machine, will yield information that cannot be obtained from the tabulated data secured by his tests; and familiarity with the strain diagrams of the materials which he is compelled to study, acquired by frequent comparison of the curves with the behavior of the metal in its applications will prove an accomplishment of exceedingly great value.

APPENDIX.

APPENDIX.

CORROSION OF IRON. (Page 331.)

Messrs. Talbot and Woodman find the following as the contents of a piece of cast iron oxidized by mine-water until seemingly converted into plumbago :*

	Outer Shell.	Inner Core.
	Per Cent.	Per Cent.
Specific gravity (compared with water at about 20 deg. C.)....	2.45	2.16
Lost on ignition at a red heat.....	7.50	8.75
Total iron.....	42.00	38.10
Total silicon.....	5.85	10.60
Total phosphorus....	3.60	3.75
Sulphur evolved by treatment with acid	2.30	0.73
Sulphur in the residue after evolution method.....	2.35	0.68
Carbon corresponding to graphitic carbon.....	9.50	16.00

After the mine had been pumped out, the metal was found to have lost its initial density and strength, and was easily broken or cut into fragments.

In the sample which came into our possession there was a well-defined demarcation between the inner core, which was gray and very soft, and the outer shell, which was black and relatively hard, although this too could be readily cut with a knife and powdered in a mortar. The two portions were easily separated by running a knife-blade along the line of demarcation. The outer and inner portions were examined separately.

* *Journal Am. Chem. Soc.*, XIX., 1; *Am. Chem. Journal*, XVIII., 849.

REQUISITES FOR PAINTING IRON. (Page 337.)

- (1) A surface free from scale or rust.
- (2) A heavy coat before shipment; even before manufacture if it appears necessary.
- (3) A pigment of anhydrous oxide of iron ground in oil.
- (4) A vehicle of linseed oil which has been blown with air at a temperature not exceeding 400 deg. Fahr., next filtered, then allowed to settle, and finally has been drawn off with a siphon.
- (5) If absolutely necessary, a dryer composed of the oxides of lead and manganese dissolved in turpentine in amount not exceeding 5 per cent. of the amount of vehicle.
- (6) A mixture of 45 per cent. of pigment to 55 per cent. of vehicle.
- (7) A careful inspection of all materials.
- (8) The performance of all work by day labor and not by contract.
- (9) Painting should not be attempted in wet or freezing weather.

SPENNRATH'S DEDUCTIONS.

(1) Every paint is destroyed by diluted chloric and nitric acids, also by vapors of the same, and sulphuric and acetic acids. Acid vapors act more rapidly than diluted solutions of the same in water. Diluted sulphuric acid does not attack an oil paint.

(2) Alkaline fluids and gases, ammonia, sulphides of ammonia, and soda solutions destroy any paint rapidly.

(3) Pure water acts more strongly than solutions of common salt, sal-ammoniac or chloride of magnesium, or natural sea-water, which are feared so much as rust-producing bodies. The amount of salt in solution reduces the effect of water on the paint. The destructive action of sea-water must be ascribed to the mechanical effect of the waves on the paint covering.

(4) Hot water acts more rapidly than water at ordinary temperature, and may even destroy oil paint in a short time.

(5) The constituents of coal-ash soluble in water act destructively in consequence of their alkaline nature. For this reason the fine ashes thrown up from chimneys and settling on painted iron surfaces are to be looked on as a danger. (*Eng'g Record*, Vol. XXXIII., No. 12.)

TENACITY OF IRONS AND STEELS. (Page 420.)

It is concluded by Mr. Campbell that :

(1) Pure iron has a tenacity of 38,000 to 39,000 lbs. per square inch.

(2) Each 0.01 carbon added raises that figure 1,200 lbs. with "acid steel," 950 with "basic."

(3) Manganese affects acid steel in insignificant degree, and adds 85 lbs. per one per cent. in the case of basic steel.

(4) Phosphorus adds tenacity, with acid steel, 890 lbs. per one per cent. ; with basic steel, 1,050 lbs.

(5) Open-hearth steel has the tenacity :

$$\text{(Acid) } T_a = 38,600 + 121C + 89P + R,$$

$$\text{(Basic) } T_b = 37,430 + 95C + 8.5Mn + 105P + R,$$

where R is a constant dependent on method of working.

(6) These deductions were made from the behavior of soft steel, but are thought applicable to harder metals.

(7) Considerable differences are observed in different makes of steel.

(8) In acid steel, above 0.06% Mn gives larger gains.

(9) In steels containing 0.3 to 0.5% C the effect of the metalloids is quite as great ; while Si in excess of 0.15% adds to the effect of C.

(10) In soft steels Si has little effect.

(11) No effect is observed due to S.

(12) With less than 0.3% Mn the deduction is made that a little iron oxide gives hardness and tenacity.*

* Campbell : Manufacture and Properties of Structural Steels.

HOMOGENEITY OF OPEN-HEARTH METAL. (H. H. CAMPBELL.)

Heat 10,699. Acid Open Hearth. Test-bars, $\frac{1}{2}$ " Rolled Rounds.				Heat 10,910. Acid Open Hearth. Test-bars, $\frac{1}{2}$ " Rolled Rounds.			
Elastic Limit. Lbs. per Sq. In.	Ultimate Strength. Lbs. per Sq. In.	Elong. in 8 In. Per Cent.	Reduct. of Area. Per Cent.	Elastic Limit. Lbs. per Sq. In.	Ultimate Strength. Lbs. per Sq. In.	Elong. in 8 In. Per Cent.	Reduct. of Area. Per Cent.
35,900	53,510	28.75	64.14	31,140	52,760	32.75	60.60
36,450	54,790	31.75	64.58	31,790	52,750	32.75	61.20
36,000	56,150	28.75	62.71	31,540	53,000	31.50	56.50
36,225	55,690	31.25	64.48	31,250	52,000	32.25	63.30
36,090	55,830	31.00	64.71	31,250	52,320	34.00	64.10
36,315	55,830	32.00	65.18	31,080	52,320	32.50	57.10
36,740	56,370	31.50	64.84	31,160	52,830	32.75	61.80
36,350	55,090	29.50	62.87	31,250	53,160	32.75	58.10
36,450	57,510	31.25	64.25	31,040	52,160	32.75	61.80
36,125	56,900	30.75	64.26	32,050	53,840	32.50	59.60
37,580	56,600	33.50	64.16	31,660	53,580	32.50	61.10
36,900	57,510	30.50	65.16	31,700	52,480	32.25	53.10
37,220	57,420	31.25	63.28	32,550	52,580	34.00	63.10
37,130	57,280	31.75	64.16	32,570	52,960	32.75	65.40
36,000	57,050	31.25	65.75	33,330	53,050	33.00	60.40
35,860	57,190	31.25	64.23	33,580	53,860	33.00	60.40
36,615	57,440	31.25	64.74
36,450	57,670	31.75	66.46
37,165	57,580	32.75	63.68
36,640	57,350	31.25	63.18
Av. 36,510	56,538	31.15	64.34	Av. 31,809	52,853	32.75	60.48

Heat 11,018. Acid Open Hearth. Test-bars, $\frac{1}{2}$ " Rolled Rounds.				Heat 1,820. Basic Open Hearth. Test-bars, $\frac{1}{2}$ " Rolled Rounds.			
Elastic Limit. Lbs. per Sq. In.	Ultimate Strength. Lbs. per Sq. In.	Elong. in 8 In. Per Cent.	Reduct. of Area. Per Cent.	Elastic Limit. Lbs. per Sq. In.	Ultimate Strength. Lbs. per Sq. In.	Elong. in 8 In. Per Cent.	Reduct. of Area. Per Cent.
36,700	58,400	28.00	66.20	33,065	48,340	34.50	71.87
37,150	57,840	30.75	65.60	31,530	47,380	35.00	72.05
37,280	56,880	29.50	58.60	33,650	48,450	35.00	72.05
36,060	56,940	28.50	53.30	31,600	48,230	37.00	74.14
36,420	56,700	30.75	63.10	33,340	49,175	36.25	70.09
36,060	57,180	30.25	65.50	32,760	48,560	33.75	72.95
35,780	56,800	31.00	65.40	33,260	47,730	35.00	74.49
36,700	57,440	30.00	63.80	32,130	48,785	34.00	71.80
35,780	56,800	31.00	65.40	32,935	48,640	34.25	71.92
36,700	57,440	30.00	63.80	33,270	49,440	34.00	71.48
35,700	56,900	32.50	67.10	32,900	47,835	34.00	72.72
37,020	57,180	31.25	59.70	31,920	48,050	33.75	71.42
37,400	57,320	30.50	68.10	32,185	48,360	36.25	74.28
37,260	56,780	30.25	67.20	33,880	48,400	33.75	73.64
37,480	57,420	31.00	66.30
Av. 36,634	57,201	30.35	63.94	Av. 32,745	48,384	34.75	72.49

NICKEL STEEL. (Page 431.)

The superiority of nickel steel for armor plate and bicycle tubing has been shown by the tests of experts, and now decided advantages are claimed for it by engineers who have made a study of material for boiler-shell plates, steamship shafts, and wheel tires and axles. The Institution of Naval Architects was informed by William Beardmore that nickel steel has proved itself worthy of the confidence placed in it by those to whom its remarkable qualities are best known. Results obtained in the direction of procuring a material for shipbuilding and engineering purposes which will meet the ever-increasing demand for greater strength and lighter sections have been eminently satisfactory. The demand is for a metal which can be worked without any special care on the part of the artisan; a metal which in shipbuilding will enable engineers to reduce the scantlings, take from the weight of the boilers, add to the strength and reliableness of the propeller shafts; a metal which will give the same results to-day and to-morrow, in China or Peru. Nickel steel is said to fulfil all these conditions, and is, in his opinion, a most suitable material with which to meet the demands for a metal stronger than steel.

Nickel steel is a metal whose elastic limit is equal to the ultimate strength of ordinary carbon steel. Mild nickel steel gives all the properties of high-carbon metal without brittleness.

Nickel steel can be bent and punched quite as successfully as ordinary carbon steel. The bends of the softer qualities in no way differ from what is expected from ordinary carbon steels, but the results obtained on bending a steel of 51 tons tensile strength are somewhat remarkable. Regarding the welding qualities of this alloy much discussion has taken place, and many different opinions are held, but Mr. Beardmore found no difficulty in welding nickel steel. The loss of strength due to punching in nickel steel of 50 to 55 tons tensile strength is 15.5 per cent., and in steels of higher tenacity 20 per cent.

These figures show the superiority of nickel steel under this treatment.

As a material for tires and axles nickel steel has many claims. It is believed that there is a wide field for its use in this direction, and were it adopted for this purpose there would be fewer accidents from failures in rolling-stock. The usual requirements are that tires stand compressing one-sixth of their diameter without cracking. The original diameter of a nickel steel tire was $39\frac{1}{2}$ inches, and it was pressed down to 19 inches without showing signs of fracture.

A very striking feature of nickel steel is this, that a crack appearing in it will not develop, as in carbon steel. One of the most frequent causes of casualties at sea is the breaking of propeller shafts due to the development of some flaw in the shaft. In Mr. Beardmore's opinion, if propeller shafts were made of nickel steel the question of failures would seldom or never be raised, from the reason that should a crack appear at all in nickel steel it will not develop as it would in ordinary carbon steel. This remark applies, of course, with equal force to railroad axles. This opinion is based on experiments. Having had a number of bars made $1\frac{1}{2}$ inches square by 18 long of nickel steel, and also of ordinary carbon steel of the same carbon content, he nicked these on one side with a cold-chisel and proceeded to subject them to the usual fatigue test in this manner: The bars were placed on supports 10 inches apart, and a weight of 10 cwt. allowed to fall on them from a height of three feet, the bars being reversed after each blow. The test was continued in each till the bars showed signs of fracture, the number of blows at this stage noted, and the experiment continued till the bars broke. The treatment of the nickel and carbon steel bars was identical, but the results were widely different. The carbon steel was fractured after 5 blows and broken after 12 blows, while it required 7 blows to fracture the nickel steel and 35 blows to break it, an increase of 147 per cent. In the case of the carbon steel the fracture is crystalline, but in the nickel it is fibrous, and shows clearly the feature emphasized—that nickel steel tears gradu-

ally, while carbon steel, once cracked, breaks short. This statement seems to verify that made by Col. Pope's experts after testing nickel steel and carbon steel for the purpose of determining what advantage, if any, one had over the other for bicycle frames, which are subjected to continual vibration and trying strains.

In a paper on "Steel for Forgings," read before the Engineers' Club of Philadelphia by Mr. A. L. Colby, it is stated that the American Government, which formerly specified for forgings steel of 28 to 30 tons tensile strength and an elastic limit of 14 tons, have increased their requirements to 36 tons and the elastic limit to 22 tons, equal to 61 per cent. of the breaking strain. Mr. Colby points out that these higher requirements are met by using nickel steel.

When steel was first used in crank-pins in place of wrought iron, a soft low-carbon steel was employed, and the failures due to "fatigue" of the metal were almost as numerous as when wrought iron was used. The broken pins showed what has been called a "fracture in detail," a gradual parting of the steel extending inward all around the piece, undoubtedly produced by the working strains repeatedly approaching the low elastic limit of the soft steel. On substituting a steel with an elastic limit of 20 tons failures were greatly diminished, and that without changing the shape or diameter of the pin.

Mr. Colby obtained his elastic limit of 20 tons by raising the carbon to 0.45 per cent. The same or even a higher yield-point can be obtained by the use of nickel with 0.17 per cent. of carbon.

In speaking of the advantages of nickel steel Mr. Colby says that nickel increases the ratio between the elastic limit and tensile strength, and also adds to the ductility of the steel. What Mr. Colby calls "mild steel" has an elastic limit of 13 tons, or 46.4 per cent. of the breaking strain. The yield-point of the medium hard steel is 16.7 tons, or 46.2 per cent. of the breaking strain. The nickel steel, however, has an elastic limit of 22.3 tons, or 58.7 per cent. of the breaking strain. Speaking

generally, it may be said that the elastic limit of the nickel steel recommended for forgings is about the ultimate strength of ordinary mild steel.

Nickel added to steel in large percentages, as 20 to 25, makes an almost non-corrodible alloy.

STRENGTH AND DUCTILITY OF CAST NICKEL-IRON ALLOYS.—RUDELOFF.

Nickel, Per cent.	Elastic Limit, Lbs. per sq. in.	Ultimate Strength, Lbs. per sq. in.	Elongation, Per cent.
0	20,761	46,072	29.7
1	23,605	47,921	26.4
2	28,724	52,614	22.7
3	34,128	57,733	20.1
4	38,251	57,733	17.6
5	46,215	63,421	10.8
8	62,852	79,916	9.6
16	58,302	0.6
30	14,077	2.2
60	17,775	53,751	36.1
93	15,357	47,210	19.0
98	12,940	43,371	17.1

PHYSICAL PROPERTIES OF MANGANESE-STEEL TEST-PIECES.* (Page 431.)

No.	Tensile Strength per Square Inch.	Elongation in 8 Inches.	Reduction of Area.
1	145,730 lbs.	50.7%
2	150,370 "	44.4%
3	155,300 "	46.8%	32.3%
4	165,300 "	24.0%	32.0%
5	154,380 "	42.6%	36.4%

Manganese-steel rails have exhibited great endurance on curves. *Molybdenum-steel* resembles tungsten-steel, is more manageable, anneals and hardens better and is less seriously affected by heat and work. *Arsenic* in small doses strengthens mild steels.

GOOD GUN-IRON.

Si.....	1.100 to 1.250%
S.....	0.015 " 0.017%
P.....	0.450 " 0.500%
Mn.....	0.400 " 0.450%

* Nos. 1, 2, and 3 are from the papers read by R. A. Hadfield before the Institution of Civil Engineers. Nos. 4 and 5 are from a paper by the same author read before the American Institute of Mining Engineers.

NICKEL STEEL: ORDNANCE BUREAU, U. S. N. (Page 431.)

No. 4,816.

Marks, U. S. N. I.

Sectional area, .25 square inch.

Diameter, ".564.

Gauged length, 3".

Applied Loads.		Elongation per Inch.	Successive Elongation per Inch.	Permanent Set.	Successive Permanent Set.	Remarks.
Total.	Per Square Inch.					
Pounds.	Pounds.	Inch.	Inch.	Inch.	Inch.	Initial load.
250	1,000	0.	0.	0.	0.	
1,250	5,000	.000100	.000100	0.	0.	
1,500	10,000	.000333	.000233	0.	0.	
5,000	20,000	.000767	.000434	0.	0.	
6,250	25,000	.001000	.000533	0.	0.	
7,500	30,000	.001267	.000633	0.	0.	
8,750	35,000	.001433	.000766	0.	0.	
9,500	38,000	.001633	.000800	0.	0.	
10,000	40,000	.001700	.000867	0.	0.	
11,250	45,000	.001933	.000933	0.	0.	
12,500	50,000	.002100	.001067	0.	0.	
13,750	55,000	.002333	.001233	0.	0.	
15,000	60,000	.002600	.001467	0.	0.	
16,250	65,000	.002733	.001633	0.	0.	
17,500	70,000	.003000	.001867	.000033	.000033	
18,750	75,000	.003300	.002100	.000033	0.	
20,000	80,000	.003600	.002300	.000100	.000067	
21,000	84,000	.003733	.002433	0.	0.	
21,250	85,000	.004000	.002667	.000333	.000233	
22,000	88,000	.004267	.002867	0.	0.	
22,250	89,000	.004333	.002966	0.	0.	
22,500	90,000	.004567	.003234	.000667	.000334	
22,750	91,000	.004700	.003333	0.	0.	
23,000	92,000	.004900	.003500	0.	0.	
23,250	93,000	.005000	.003600	0.	0.	
23,500	94,000	.005300	.003800	0.	0.	
23,750	95,000	.005400	.003900	0.	0.	
24,000	96,000	.005733	.004333	0.	0.	
24,250	97,000	.006000	.004667	0.	0.	
24,500	98,000	.006500	.005300	0.	0.	
24,750	99,000	.006867	.005867	0.	0.	
25,000	100,000	.007400	.006333	0.	0.	
26,000	104,000	.0133	.0059	0.	0.	
27,000	108,000	.0233	.0167	0.	0.	
28,000	112,000	.0400	.0200	0.	0.	
29,000	116,000	.0600	.0200	0.	0.	
30,000	120,000	.0800	.0267	0.	0.	
31,000	124,000	.1067	.0666	0.	0.	
32,000	128,000	.1733	0.	0.	0.	
32,710	130,840	0.	0.	0.	0.	Tensile strength.

GENERAL SUMMARY.

Specific gravity.....	8.0683
Hardness.....	31.30
Tensile strength per square inch of original section.....	pounds 130,840
Elastic limit per square inch of original section.....	pounds 84,000
Elongation per inch after rupture.....	inch .2533
Elongation per inch under strain at elastic limit.....	inch .003733
Reduction in diameter at point of rupture.....	inch .184
Reduction in area after rupture, per cent. of original section.....	54.6
Position of rupture.....	.74" from neck
Character of broken surface.....	fine silky; cup-shaped ends; serrated radial lines
Elongation of inch sections.....	.12", .19", .45"

CHEMICAL COMPOSITION.

	Per Cent.
Carbon.....	0.531
Manganese.....	0.813
Silicon.....	0.370
Sulphur.....	0.202
Phosphorus.....	0.026
Nickel.....	30.970

NICKEL STEEL.

No. 4,881.

Marks, S J N.
Diameter, ".564.Sectional area, .25 square inch.
Gauged length, 3".

Applied Loads.		Elongation per Inch.	Successive Elongation per Inch.	Permanent Set.	Successive Permanent Set.	Remarks.	
Total.	Per Square Inch.						
Pounds.	Pounds.	Inch.	Inch.	Inch.	Inch.		
250	1,000	0.	0.	0.	0.	Initial load.	
1,250	5,000	.000100	.000100	0.	0.		
2,500	10,000	.000333	.000233	0.	0.		
5,000	20,000	.000700	.000367	0.	0.		
7,500	30,000	.001000	.000300	0.	0.		
8,750	35,000	.001200	.000200	0.	0.		
10,000	40,000	.001367	.000167	0.	0.		
11,250	45,000	.001567	.000200	0.	0.		
12,500	50,000	.001700	.000133	0.	0.		
13,750	55,000	.001933	.000233	0.	0.		
14,000	56,000	.002000	.000067	0.	0.		Elastic limit.
14,250	57,000	.010200	.008200	0.	0.		
14,500	58,000	.011700	.001500	0.	0.		
14,750	59,000	.012400	.000700	0.	0.		
15,000	60,000	.013667	.001267	0.	0.		
15,250	61,000	.015000	.001333	0.	0.		
15,500	62,000	.016000	.001000	0.	0.		
15,750	63,000	.017000	.001000	0.	0.		
16,000	64,000	.017700	.000700	0.	0.		
16,500	66,000	.020667	.002967	0.	0.		
17,000	68,000	.023333	.002666	0.	0.		
17,500	70,000	.026333	.003000	0.	0.		
18,000	72,000	.029333	.003000	0.	0.		
18,500	74,000	.033000	.003667	0.	0.		
19,000	76,000	.036000	.003333	0.	0.		
19,500	78,000	.041000	.004667	0.	0.		
20,000	80,000	.046000	.005000	0.	0.		
20,500	82,000	.051333	.005333	0.	0.		
21,000	84,000	.057333	.006000	0.	0.		
21,500	86,000	.066333	.009000	0.	0.		
22,000	88,000	.079667	.013334	0.	0.		
22,500	90,000	.1000	.020333	0.	0.		
22,860	91,440	Tensile strength.	

GENERAL SUMMARY.

Tensile strength per square inch of original section.....	pounds	91,440
Elastic limit per square inch of original section.....	pounds	56,000
Elongation per inch after rupture.....	inch	.2367
Elongation per inch under strain at elastic limit.....	inch	.002000
Reduction in diameter at point of rupture.....	inch	.174
Reduction in area after rupture, per cent. of original section.....		52.2
Position of rupture.....	inch	1".5 from neck
Character of broken surface.....		fine silky, cup-shaped
Elongation of inch sections.....		.14", .40", .17"

CHEMICAL COMPOSITION.

	Per Cent.
Total carbon.....	0.320
Graphitic carbon.....	0.040
Combined carbon.....	0.280
Manganese.....	0.660
Silicon.....	0.173
Sulphur.....	0.057
Phosphorus.....	0.022
Copper.....	0.000
Nickel.....	3.152

NICKEL STEEL.

No. 4,759.

Marks, ^A_N
Diameter, ".564.

Sectional area, .25 square inch.
Gauged length, 3".

Applied Loads.		Elongation per Inch.	Successive Elongation per Inch.	Permanent Set.	Successive Permanent Set.	Remarks.
Total.	Per Square Inch.					
Pounds.	Pounds.	Inch.	Ioeh.	Inch.	Inch.	
250	1,000	o.	o.	o.	o.	Initial load.
1,250	5,000	.000100	.000100	o.	
2,500	10,000	.000333	.000233	
5,000	20,000	.000667	.000334	
7,500	30,000	.001000	.000333	o.	
8,750	35,000	.001133	.000133	
10,000	40,000	.001333	.000200	o.	
11,250	45,000	.001467	.000134	
12,500	50,000	.001667	.000200	
13,750	55,000	.001833	.000166	
14,000	56,000	.001900	.000067	Elastic limit. Load fell.
12,750	51,000	.013667	.011767	
13,000	52,000	.018433	.004766	
13,250	53,000	.019067	.000634	
13,500	54,000	.019667	.000600	
13,750	55,000	.020400	.000733	
14,000	56,000	.021867	.001407	
14,250	57,000	.022700	.000833	
14,500	58,000	.024333	.001633	
15,000	60,000	.027667	.003334	
15,500	62,000	.030833	.003166	
16,000	64,000	.034667	.003834	
16,500	66,000	.039167	.004500	
17,000	68,000	.044000	.004833	
17,500	70,000	.050267	.006267	
18,000	72,000	.0000	.009733	
18,500	74,000	.0667	.0067	
19,000	76,000	.0833	.0166	
19,500	78,000	.1033	.0200	
19,950	79,800	.1733	.0700	Tensile strength.
16,100	Load at time of rupture.

GENERAL SUMMARY.

Tensile strength per square inch of original section.....	pounds	79,800
Elastic limit per square inch of original section.....	pounds	56,000
Elongation per inch after rupture.....	inch	.2767
Elongation per inch under strain at elastic limit.....	inch	.001900
Reduction in diameter at point of rupture.....	inch	.174
Reduction in area after rupture, per cent. of original section.....		52.2
Position of rupture.....	1" / 3	from neck
Character of broken surface.....		fine silky
Elongation of inch sections.....	.18", .42", .23"	

CHEMICAL COMPOSITION.

	Per Cent.
Total carbon.....	0.402
Graphitic carbon.....	0.027
Combined carbon.....	0.375
Manganese.....	0.433
Silicon.....	0.146
Sulphur.....	0.010
Phosphorus.....	0.031
Copper.....	None
Nickel.....	0.950

RIFLE-BARREL STEEL. (CARBON.)

No. 4,880.

Marks, A I 2.

Sectional area, .25 square inch.

Diameter, ".564.

Gauged length, 3".

Applied Loads.		Elongation per Inch.	Successive Elongation per Inch.	Permanent Set.	Successive Permanent Set.	Remarks.
Total.	Per Square Inch.					
Pounds.	Pouods.	Inch.	Inch.	Inch.	Inch.	Initial load.
250	1,000	0.	0.	0.	0.	
1,250	5,000	.000067	.000067	0.	0.	
2,500	10,000	.000333	.000266	0.	0.	
5,000	20,000	.000667	.000334	0.	0.	
7,500	30,000	.001033	.000366	0.	0.	
10,000	40,000	.001333	.000300	0.	0.	
11,250	45,000	.001567	.000234	0.	0.	
12,500	50,000	.001700	.000133	0.	0.	
13,750	55,000	.001933	.000233	0.	0.	
14,000	56,000	.002000	.000067	0.	0.	
14,250	57,000	.002000	0.	0.	0.	
14,500	58,000	.002033	.000033	0.	0.	
14,750	59,000	.002033	0.	0.	0.	
15,000	60,000	.002067	.000034	.000033	.000033	
15,250	61,000	.010367	.008300	0.	0.	
15,500	62,000	.011267	.000900	0.	0.	
15,750	63,000	.011700	.000433	0.	0.	
16,000	64,000	.012667	.000667	0.	0.	
16,250	65,000	.013533	.000866	0.	0.	
16,500	66,000	.014400	.000867	0.	0.	
17,000	68,000	.016167	.001767	0.	0.	
17,500	70,000	.018400	.002233	0.	0.	
18,000	72,000	.020167	.001767	0.	0.	
18,500	74,000	.022500	.002333	0.	0.	
19,000	76,000	.024667	.002167	0.	0.	
19,500	78,000	.027333	.002666	0.	0.	
20,000	80,000	.029667	.002334	0.	0.	
20,500	82,000	.032667	.003000	0.	0.	
21,000	84,000	.036000	.003333	0.	0.	
21,500	86,000	.039333	.003333	0.	0.	
22,000	88,000	.044000	.004667	0.	0.	
22,500	90,000	.048333	.004333	0.	0.	
23,000	92,000	.054000	.005667	0.	0.	
23,500	94,000	.0600	.0060	0.	0.	
24,000	96,000	.0733	.0133	0.	0.	
24,500	98,000	.0900	.0167	0.	0.	
24,910	99,640	Tensile strength.

GENERAL SUMMARY.

Tensile strength per square inch of original section	pounds	99,640
Elastic limit per square inch of original section	pounds	60,000
Elongation per inch after rupture	inch	.1900
Elongation per inch under strain at elastic limit	inch	.002067
Reduction in diameter at point of rupture	inch	.104
Reduction in area after rupture, per cent. of original section		33.5
Position of rupture	1"	5 from neck
Character of broken surface		silky, 50 per cent.; fine granular, 50 per cent.
Elongation of inch sections	13", 28", 16"	

CHEMICAL COMPOSITION.

	Per Cent.
Total carbon	0.354
Graphitic carbon	0.029
Combined carbon	0.325
Manganese	0.677
Silicon	0.047
Sulphur	0.057
Phosphorus	0.023
Copper	0.000

FLUCTUATION OF QUALITY WITH COMPOSITION.*
(Page 440.)

TABLE I. EMBREVILLE IRON.

Tensile strength. Silicon, sulphur, phosphorus constant. Carbons variable.

Series No.	Grade Melted.	Analysis Test-bars.					Grain after Melting.	Physical Tests.		
		Silicon.	Sulphur.	Phosphorus.	Graphite.	Compound Carbon.		Bar. R. Sq. Inch.	Break-ing Strain.	Per Square Inch.
1	1 F.	1.20	0.066	0.175	3.72	0.15	Very open	1 1/2	7,750	17,500
2	1 F.	1.24	0.053	0.179	3.65	0.20	Very open	1 1/2	7,800	17,650
3	2 F.	1.29	0.067	0.170	3.50	0.28	Open bright	1 1/2	9,850	22,300
4	2 F.	1.21	0.069	0.179	3.52	0.33	Open bright	1 1/2	9,900	22,400
5	2 F.	1.28	0.057	0.171	3.49	0.35	Open bright	1 1/2	10,050	19,350
6	2 F.	1.27	0.063	0.175	3.58	0.32	Open bright	1 1/2	9,750	18,800
7	3 F.	1.20	0.068	0.175	3.45	0.39	Close bright	1 1/2	11,100	21,400
8	3 F.	1.20	0.066	0.170	3.42	0.40	Close bright	1 1/2	10,850	24,550
9	G. F.	1.29	0.053	0.175	3.48	0.35	Gray	1 1/2	10,650	24,100
10	G. F.	1.28	0.055	0.179	3.34	0.56	Gray	1 1/2	13,200	29,850
11	G. F.	1.25	0.066	0.170	3.32	0.61	Gray	1 1/2	12,950	24,950
12	G. F.	1.25	0.067	0.170	2.88	0.98	Very close gray	1 1/2	17,450	33,650
13	G. F.	1.21	0.061	0.174	2.95	0.93	Very close gray	1 1/2	17,550	33,850
14	G. F.	1.29	0.053	0.179	2.84	0.92	Very close gray	1 1/2	15,900	35,950

TABLE II. EMBREVILLE IRON.

Tensile strength. Silicon, sulphur, carbons constant. Phosphorus variable.

1	G. F.	1.09	0.080	0.121	3.03	0.78	Gray	1 1/2	13,250	25,550
2	G. F.	1.10	0.072	0.143	3.10	0.79	Gray	1 1/2	12,900	24,950
3	G. F.	1.01	0.075	0.150	2.93	0.82	Gray	1 1/2	12,700	28,750
4	G. F.	1.13	0.081	0.174	3.00	0.81	Gray	1 1/2	13,100	25,250
5	G. F.	1.08	0.076	0.208	2.89	0.88	Gray	1 1/2	12,900	24,850
6	G. F.	1.06	0.078	0.247	2.96	0.85	Close gray	1 1/2	13,400	30,300
7	G. F.	1.11	0.083	0.303	3.02	0.75	Close gray	1 1/2	13,350	30,200
8	G. F.	1.03	0.073	0.354	2.96	0.83	Close gray	1 1/2	11,900	22,950
9	G. F.	1.02	0.078	0.412	2.91	0.85	Light gray	1 1/2	10,850	24,550
10	G. F.	1.09	0.081	0.453	2.83	0.80	Light gray	1 1/2	10,100	19,450
11	G. F.	1.07	0.073	0.517	2.80	0.88	Light gray	1 1/2	10,050	19,350
12	G. F.	1.07	0.082	0.554	2.83	0.81	Light gray	1 1/2	10,750	20,700

* On the Action of Metalloids on Cast Iron, by Guy R. Johnson, Embreville, Tennessee—a paper presented to the Iron and Steel Institute (Stockholm meeting, August, 1898).

TABLE III. EMBREVILLE IRON.

Tensile strength. Phosphorus, sulphur, carbons constant. Silicon variable.

Series No.	Grade Melted.	Analysis Test-bars.					Physical Tests.			
		Silicon.	Sulphur.	Phosphorus.	Graphite.	Compound Carbon.	Grain after Melting.	Bar. R. Sq. Inch.	Breaking Strain.	Per Square Inch.
1	...	0.31	0.071	0.179	3.03	0.79	Gray	1 1 1 1 1 1 1 1	13,950	31,550
2	...	0.53	0.068	0.181	2.94	0.83	Gray		12,800	28,950
3	...	0.74	0.074	0.184	2.98	0.81	Gray		13,100	25,250
4	...	1.01	0.077	0.183	3.07	0.78	Gray		13,250	25,550
5	...	1.27	0.070	0.178	2.98	0.85	Gray		12,850	29,050
6	...	1.55	0.068	0.185	2.94	0.83	Gray		12,500	28,300
7	...	1.76	0.067	0.179	3.07	0.83	Gray		11,850	22,850
8	...	2.03	0.073	0.179	2.01	0.80	Gray		10,200	19,650

No "grade melted" given. Mixtures used to obtain comparisons noted.

TABLE IV. EMBREVILLE IRON.

Tensile strength. Silicon, phosphorus, carbons constant. Sulphur variable.

1	...	1.22	0.051	0.203	2.98	0.83	Gray	1 1 1 1 1	13,100	25,250
2	...	1.19	0.072	0.197	3.07	0.80	Gray		12,650	24,400
3	...	1.25	0.109	0.198	3.03	0.78	Gray		12,950	24,950
4	...	1.23	0.141	0.202	2.96	0.97	Close gray		15,750	35,650
5	...	1.26	0.172	0.207	2.99	0.92	Close gray		17,200	33,150

* * * * *

"TOUGHENED" IRONS (*Containing Wrought Scrap*).

Major M'Dowell's Test.

	Per Cent.
Silicon.....	1.34
Sulphur.....	0.03
Phosphorus.....	0.08
Manganese.....	1.00
Graphitic carbon.....	2.19
Combined carbon.....	0.93

Tensile strength, 49,900 lbs. per square inch.

Graphitic carbon renders an iron soft, easily machined, and less apt to be brittle, but, owing to its disturbing continuity, decreases tensile strength.

Johnson's Test.

	Per Cent.
Silicon.....	0.94
Sulphur.....	0.037
Phosphorus.....	0.192
Manganese.....	0.21
Graphitic carbon.....	2.58
Combined carbon.....	0.46

Tensile strength of bar turned from the centre of a full-sized pig, 34,010 lbs.

This experiment was repeated many times, varying the proportion of wrought scrap each time, but the results in each case clearly established the fact that by lowering the total carbons the iron is made stronger.

* * * * *

“A locomotive cylinder has to resist great wear, must be of great tensile strength and density, and yet be capable of being machined properly. As we might expect, an iron having a No. 3 or gray forge fracture is employed in the best practice. For ordinary castings, however, a much softer iron is preferable, and accordingly we find Nos. 1 and 2 being used in such work, and being mixed, of course, with other grades and scrap, as suits the idea of the foundryman.

“It is not difficult to transform graphitic carbon into combined carbon. Chilling has this effect, and the re-melting in the foundry, combined with the chilling of the sand mould, generally produces the desired grain; while by using metal chills and sufficiently low silicon contents all of the graphitic carbon will be changed to combined carbon, giving a white iron. Sufficient repetition of re-melting, with the consequent loss of silicon, will make a perfectly gray iron white. In malleable work an air-furnace is used to produce this effect on the first melt, though in this class of work the process is carried further and more of the carbon is burned off.”

RESISTANCE OF STEEL BALLS. (Page 457.)

The following gives the tabulated data and shows the poorest as well as the best results for each size of steel ball (*Journal of Engineering*, Sibley College, 1895):

Number.	Diameter.	Maximum Crushing Load. Average of 3 Tests.	Minimum Crushing Load. Average of 3 Tests.	Number of Sets of 3.
1	1 1/4"	10,683	5,566	21
2	1 1/8"	3,500	2,923	3
3	1 1/8"	11,026	7,460	3
4	1 1/8"	17,690	1
5	1 1/8"	39,766	1
6	1 1/8"	30,426	23,990	3
7	1"	55,210	1
8	2"	220,000	Only 1 ball tested

SPECIFICATIONS FOR CAST IRONS. (Page 629.)

Elements.	Proportions Required.				
	I. Per Cent.	II. Per Cent.	III. Per Cent.	IV. Per Cent.	V. Per Cent.
Graphitic carbon.....	3.20	3.30	2.90	3.00	3.00*
Combined "	0.30	0.20	0.40	0.30	0.30
Silicon.....	2.75	3.00	2.40	2.60	2.50
Phosphorus.....	0.60	0.80	0.60	0.80	0.90
Manganese.....	0.60	0.50	0.60	0.50	0.30
Sulphur.....	0.015	0.01	0.02	0.015	0.02

I.—No. 1 X Foundry for the manufacture of pulleys, small machinery castings, etc.

II.—No. 1 X Foundry for carrying harder pig iron or scrap, and for making choice light hardware castings, etc.

III.—No. 2 X Foundry for heavy machinery castings, etc.

IV.—No. 2 X Foundry for carrying harder iron, and for light machinery castings, stove-plates, etc.

V.—No. 2 Plain Foundry. There is a wide variation in the specifications for this grade, which is more frequently sold without guaranty than any other.*

* *Engineering News*, March 26, 1896.

REVISED STANDARD SPECIFICATIONS FOR WROUGHT IRON.*

PROCESS OF MANUFACTURE.

1. Wrought iron shall be made by the puddling or by the charcoal hearth process or rolled from fagots or piles made from wrought-iron scrap, alone or with muck-bar added.

PHYSICAL PROPERTIES.

2. *Tensile Test.*—The minimum physical qualities required in the four classes of wrought iron shall be as follows :

	Stay-bolt Iron.	Merchant Iron. Grade "A."	Merchant Iron. Grade "B."	Merchant Iron. Grade "C."
Tensile strength, pounds per sq. inch.....	46,000	50,000	48,000	48,000
Yield point, pounds per sq inch.....	25,000	25,000	25,000	25,000
Elongation per cent. in 8 inches.....	28	25	20	20

3. In sections weighing less than 0.654 pound per linear foot, the percentage of elongation required in the four classes specified in paragraph No. 2 shall be 21 per cent., 18 per cent., 15 per cent., and 12 per cent., respectively.

4. *Nicking Test.*—The four classes of iron when nicked and tested as described in paragraph No. 9, shall show the following fracture :

(a) Stay-bolt iron, a long, clean, silky fibre, free from slag or dirt, and wholly fibrous, being practically free from crystalline spots.

(b) Merchant iron, Grade "A," a long, clean, silky fibre, free from slag or dirt or any coarse crystalline spots. A few fine crystalline spots may be tolerated, provided they do not in the aggregate exceed 10 per cent. of the sectional area of the bar.

(c) Merchant iron, Grade "B," a generally fibrous fracture,

* International Assoc. for Testing Materials, 1901.

free from coarse crystalline spots. Not over 10 per cent. of the fractured surface shall be granular.

(*d*) Merchant iron, Grade "C," a generally fibrous fracture, free from coarse crystalline spots. Not over 15 per cent. of the fractured surface shall be granular.

5. *Cold-bending Test*.—The four classes of iron, when tested as described in paragraph No. 10, shall conform to the following bending tests :

(*e*) Stay-bolt iron; a piece of stay-bolt iron about 24 inches long shall bend in the middle through 180° flat on itself, and then bend in the middle through 180° flat on itself in a plane at a right angle to the former direction, without a fracture on outside of the bent portions. Another specimen with a thread cut over the entire length shall stand this double bending without showing deep cracks in the threads.

(*f*) Merchant iron, Grade "A," shall bend cold 180° flat on itself without fracture on outside of the bent portion.

(*g*) Merchant iron, Grade "B," shall bend cold 180° around a diameter equal to the thickness of the tested specimen, without fracture on outside of the bent portion.

(*h*) Merchant iron, Grade "C," shall bend cold 180° around a diameter equal to twice the thickness of the specimen tested, without fracture on outside of the bent portion.

6. *Hot-bending Test*.—The four classes of iron, when tested as described in paragraph No. 11, shall conform to the following hot-bending tests :

(*i*) Stay-bolt iron, shall bend through 180° flat on itself, without showing cracks or flaws. A similar specimen heated to a yellow heat and suddenly quenched in water between 80° and 90° F. shall bend, without hammering on the bend, 180° flat on itself without showing cracks or flaws.

(*j*) Merchant iron, Grade "A," shall bend through 180° flat on itself, without showing cracks or flaws. A similar specimen heated to a yellow heat and suddenly quenched in water between 80° and 90° F. shall bend, without hammering

on the bend, 180° flat on itself without showing cracks or flaws. A similar specimen heated to a bright-red heat shall be split at the end and each part bent back through an angle of 180° . It will also be punched and expanded by drifts until a round hole is formed whose diameter is not less than nine-tenths of the diameter of the rod or width of the bar. Any extension of the original split or indications of fracture, cracks, or flaws, developed by the above tests will be sufficient cause for the rejection of the lot represented by that rod or bar.

(k) Merchant iron, Grade "B," shall bend through 180° flat on itself, without showing cracks or flaws.

(l) Merchant iron, Grade "C," shall bend sharply to a right angle, without showing cracks or flaws.

7. *Threading Test*.—Stay-bolt iron shall permit of the cutting of a clean sharp thread and be rolled true to gauges desired, so as not to jam in the threading dies.

TEST PIECES AND METHODS OF TESTING.

8. *Test Specimen for Tensile Test*.—Whenever possible, iron shall be tested in full size as rolled, to determine the physical qualities specified in paragraphs Nos. 2 and 3, the elongation being measured on an eight-inch (8") gauged length. In flats and shapes too large to test as rolled, the standard test specimen shall be one and one-half inches ($1\frac{1}{2}$ ") wide and eight inches (8") gauged length.

In large rounds, the standard test specimen of two inches (2") gauged length shall be used; the centre of this specimen shall be half-way between the centre and outside of the round. Sketches of these two standard test specimens are as shown in figures on page 686.

9. *Nicking Tests*.—Nicking tests shall be made on specimens cut from the iron as rolled. The specimen shall be slightly and evenly nicked on one side and bent back at this point through an angle of 180° by a succession of light blows.

10. *Cold-bending Tests*.—Cold-bending tests shall be made on specimens cut from the bar as rolled. The specimen

shall be bent through an angle of 180° by pressure or by a succession of light blows.

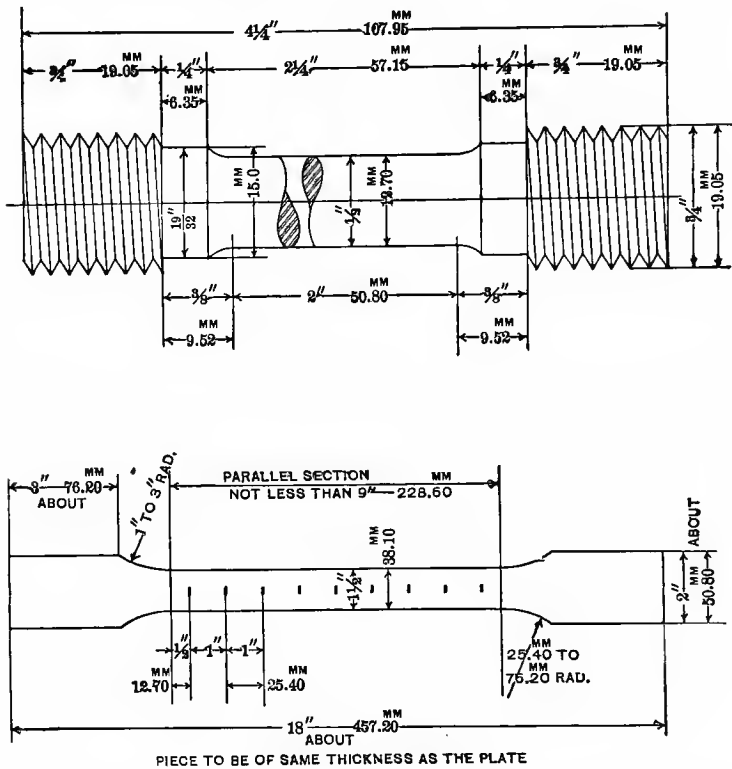

11. *Hot-bending Tests.*—Hot-bending tests shall be made on specimens cut from the bar as rolled. The specimens, heated to a bright-red heat, shall be bent through an angle of 180° by pressure or by a succession of light blows and without hammering directly on the bend.

If desired, a similar bar of any of the four classes of iron shall be worked and welded in the ordinary manner without showing signs of red shortness.

12. *Yield Point.*—The yield point specified in paragraph

No. 2 shall be determined by the careful observation of the drop of the beam or halt in the gauge of the testing machine.

FINISH.

13. All wrought iron must be practically straight, smooth, free from cinder spots or injurious flaws, buckles, blisters, or cracks.

In round iron, sizes must conform to the Standard Limit gauge as adopted by the Master Car Builders' Association in November, 1883.

INSPECTION.

14. Inspectors representing the purchasers shall have all reasonable facilities afforded them by the manufacturer to satisfy them that the finished material is furnished in accordance with these specifications. All tests and inspections shall be made at the place of manufacture prior to shipment.

OPEN-HEARTH BOILER PLATES AND RIVETS.

PROCESS OF MANUFACTURE.

1. Steel shall be made by the open-hearth process.

CHEMICAL PROPERTIES.

2. There shall be three classes of open-hearth boiler plate and rivet steel, namely, FLANGE or BOILER STEEL, FIRE-BOX STEEL, and EXTRA-SOFT STEEL, which shall conform to the following limits in chemical composition :

	Flange or Boiler Steel. Per cent.	Fire-box Steel. Per cent.	Extra-soft Steel. Per cent.
Phosphorus shall not exceed..	{ Acid 0.06 Basic 0.04	{ Acid 0.04 Basic 0.03	0.04
Sulphur shall not exceed.....	0.05	0.04	0.04
Manganese.....	0.30 to 0.60	0.30 to 0.50	0.30 to 0.50

3. *Boiler-rivet Steel.*—Steel for boiler rivets shall be of the EXTRA-SOFT class as specified in paragraphs Nos. 2 and 4.

PHYSICAL PROPERTIES.

4. The three classes of open-hearth boiler plate and rivet steel, namely, FLANGE or BOILER STEEL, FIRE-BOX STEEL, and EXTRA-SOFT STEEL, shall conform to the following physical qualities :

Tensile Tests.—

	Flange or Boiler Steel.	Fire-box Steel.	Extra-soft Steel.
Tensile strength, pounds per square inch.....	55,000 to 65,000	52,000 to 62,000	45,000 to 55,000
Yield point, in pounds per square inch shall not be less than.....	$\frac{1}{2}$ T. S.	$\frac{1}{2}$ T. S.	$\frac{1}{2}$ T. S.
Elongation, per cent. in eight inches shall not be less than.....	25	26	28

5. *Modifications in Elongation for Thin and Thick Material.*—For material less than five-sixteenths inch ($\frac{5}{16}$ "') and more than three-fourths inch ($\frac{3}{4}$ "') in thickness the following modifications shall be made in the requirements for elongation:

(a) For each increase of one-eighth inch ($\frac{1}{8}$ "') in thickness above three-fourths inch ($\frac{3}{4}$ "') a deduction of one per cent. (1%) shall be made from the specified elongation.

(b) For each decrease of one-sixteenth inch ($\frac{1}{16}$ "') in thickness below five-sixteenths inch ($\frac{5}{16}$ "') a deduction of two and one-half per cent. ($2\frac{1}{2}$ %) shall be made from the specified elongation.

6. *Bending Tests.*—The three classes of open-hearth boiler-plate and rivet steel shall conform to the following bending tests ; and for this purpose the test specimen shall be one and one-half inches ($1\frac{1}{2}$ "') wide if possible, and for all material three-fourths inch ($\frac{3}{4}$ "') or less in thickness the test specimen shall be of the same thickness as that of the finished material from which it is cut ; but for material more than three-fourths inch ($\frac{3}{4}$ "') thick, the bending-test specimen may be one-half inch ($\frac{1}{2}$ "') thick :

Rivet rounds shall be tested of full size as rolled.

(c) Test specimens cut from the rolled material as specified above, shall be subjected to a cold-bending test, and also to a

quenched-bending test. The cold-bending test shall be made on the material in the condition in which it is to be used, and prior to the quenched-bending test, the specimen shall be heated to a light cherry-red as seen in the dark and quenched in water, the temperature of which is between 80° and 90° Fahrenheit.

(d) Flange or boiler steel, fire-box steel and rivet steel, both before and after quenching, shall bend cold one hundred and eighty degrees (180°) flat on itself without fracture on the outside of the bent portion.

7. *Homogeneity Tests.*—For fire-box steel a sample taken from a broken tensile test specimen shall not show any single seam or cavity more than one-fourth inch ($\frac{1}{4}$ " long in either of the three fractures obtained on the test for homogeneity as described below in paragraph 12.

TEST PIECES AND METHODS OF TESTING.

8. *Test Specimen for Tensile Test.*—The standard test specimen of eight-inch (8") gauged length shall be used to determine the physical properties specified in paragraphs Nos. 4 and 5. The standard shape of the test specimen for sheared plates shall be as shown by the following sketch:

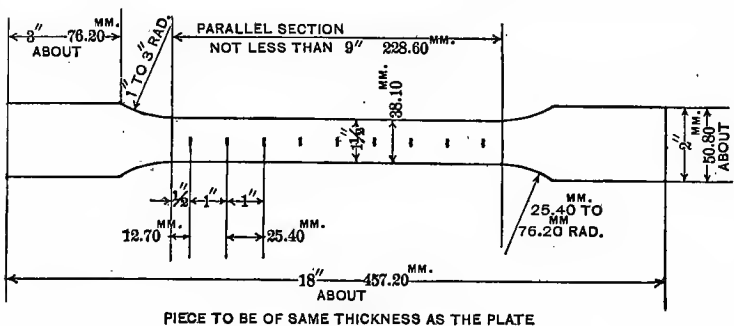

For other material the test specimen may be the same as for sheared plates, or it may be planed or turned parallel

throughout its entire length, and in all cases where possible, two opposite sides of the test specimens shall be the rolled surface. Rivet rounds and small rolled bars shall be tested of full size as rolled.

9. *Number of Tensile Tests.*—One tensile-test specimen will be furnished from each plate as it is rolled, and two tensile-test specimens will be furnished from each melt of rivet rounds. In case any one of these develops flaws or breaks outside of the middle third of its gauged length, it may be discarded and another test specimen substituted therefor.

10. *Test Specimens for Bending.*—For material three-fourths inch ($\frac{3}{4}$ ") or less in thickness, the bending-test specimens shall have the natural rolled surface on two opposite sides. The bending-test specimens cut from plates shall be one and one-half inches ($1\frac{1}{2}$ ") wide and for material more than three-fourths inch ($\frac{3}{4}$ ") thick the bending-test specimens may be one-half inch ($\frac{1}{2}$ ") thick. The sheared edges of bending-test specimens may be milled or planed. The bending-test specimens for rivet rounds shall be of full size as rolled. The bending test may be made by pressure or by blows.

11. *Number of Bending Tests.*—One cold-bending specimen and one quenched-bending specimen will be furnished from each plate as it is rolled. Two cold-bending specimens and two quench-bending specimens will be furnished from each melt of rivet rounds. The homogeneity test for fire-box steel shall be made on one of the broken tensile-test specimens.

12. *Homogeneity Tests for Fire-box Steel.*—The homogeneity test for fire-box steel is made as follows: A portion of the broken tensile-test specimen is either nicked with a chisel or grooved on a machine, transversely about a sixteenth of an inch ($\frac{1}{16}$ ") deep, in three places about two inches (2") apart. The first groove should be made on one side, two inches (2 ") from the square end of the specimen ; the second, two inches (2") from it on the opposite side ; and the third, two inches (2") from the last, and on the opposite side from it. The test specimen is then put in a vise, with the first groove about a

quarter of an inch ($\frac{1}{4}$ "') above the jaws, care being taken to hold it firmly. The projecting end of the test specimen is then broken off by means of a hammer, a number of light blows being used, and the bending being away from the groove. The specimen is broken at the other two grooves in the same way. The object of this treatment is to open and render visible to the eye any seams due to failure to weld up, or to foreign interposed matter, or cavities due to gas bubbles in the ingot. After rupture, one side of each fracture is examined, a pocket lens being used if necessary, and the length of the seams and cavities is determined.

13. *Yield Point.*—For the purposes of this specification the yield point shall be determined by the careful observation of the drop of the beam or halt in the gauge of the testing machine.

14. *Sample for Chemical Analysis.*—In order to determine if the material conforms to the chemical limitations prescribed in paragraph No. 2 herein, analysis shall be made of drillings taken from a small test ingot. An additional check analysis may be made from a tensile specimen of each melt used on an order other than in locomotive fire-box steel. In the case of locomotive fire-box steel a check analysis may be made from the tensile specimen from each plate as rolled.

VARIATION IN WEIGHT.

15. The variation in cross-section or weight of more than $2\frac{1}{2}$ per cent. from that specified will be sufficient cause for rejection, except in the case of sheared plates, which will be covered by the following permissible variations:

(e) Plates $12\frac{1}{2}$ pounds per square foot or heavier, up to 100 inches wide, when ordered to weight, shall not average more than $2\frac{1}{2}$ per cent. variation above or $2\frac{1}{2}$ per cent. below the theoretical weight. When 100 inches wide and over, 5 per cent. above or 5 per cent. below the theoretical weight.

(f) Plates under $12\frac{1}{2}$ pounds per square foot, when ordered

to weight, shall not average a greater variation than the following:

Up to 75 inches wide, $2\frac{1}{2}$ per cent. above or $2\frac{1}{2}$ per cent. below the theoretical weight. 75 inches wide up to 100 inches wide, 5 per cent. above or 3 per cent. below the theoretical weight. When 100 inches wide and over, 10 per cent. above or 3 per cent. below the theoretical weight.

* * * * *

(g) For all plates ordered to gauge, there will be permitted an average excess of weight over that corresponding to the dimensions on the order equal in amount to that specified in the following table:

TABLE OF ALLOWANCES FOR OVERWEIGHT FOR RECTANGULAR PLATES WHEN ORDERED TO GAUGE.

Plates will be considered up to gauge if measuring not over $1/100$ inch less than the ordered gauge.

The weight of 1 cubic inch rolled steel is assumed to be 0.2833 pound.

Plates 1/4 Inch and over in Thickness.

Thickness of Plate. Inch.	Width of Plate.		
	Up to 75 Inches. Per cent.	75 to 100 Inches. Per cent.	Over 100 Inches. Per cent.
1/4	10	14	18
5/16	8	12	16
3/8	7	10	13
7/16	6	8	10
1/2	5	7	9
9/16	$4\frac{1}{2}$	$6\frac{1}{2}$	$8\frac{1}{2}$
5/8	4	6	8
Over 5/8	$3\frac{1}{2}$	5	$6\frac{1}{2}$

Plates under 1/4 Inch in Thickness.

Thickness of Plate. Inch.	Width of Plate.	
	Up to 50 Inches. Per cent.	50 Inches and Above. Per cent.
1/8 up to 5/32	10	15
5/32 " 3/16	$8\frac{1}{2}$	$12\frac{1}{2}$
3/16 " 1/4	7	10

FINISH.

16. All finished material shall be free from injurious surface defects and laminations, and must have a workmanlike finish.

BRANDING.

17. Every finished piece of steel shall be stamped with the melt number, and each plate, and the coupon or test specimen cut from it, shall be stamped with a separate identifying mark or number. Rivet steel may be shipped in bundles securely wired together with the melt number on a metal tag attached.

INSPECTION.

18. The inspector representing the purchaser shall have all reasonable facilities afforded to him by the manufacturer to satisfy him that the finished material is furnished in accordance with these specifications. All tests and inspections shall be made at the place of manufacture prior to shipment.

STRUCTURAL STEEL FOR BUILDINGS AND SHIPS.

PROCESS OF MANUFACTURE.

1. Steel shall be made by the open-hearth process.

CHEMICAL PROPERTIES.

2. Each of the three classes of structural steel for bridges and ships shall conform to the following limits in chemical composition :

	Steel Made by the Acid Process. Per cent.	Steel Made by the Basic Process. Per cent.
Phosphorus shall not exceed.....	0.08	0.06
Sulphur shall not exceed.....	0.06	0.06

PHYSICAL PROPERTIES.

3. *Classes.*—There shall be three classes of structural steel for bridges and ships, namely, RIVET STEEL, SOFT STEEL, and MEDIUM STEEL, which shall conform to the following physical qualities :

4. *Tensile Tests.*—

	Rivet Steel.	Soft Steel.	Medium Steel.
Tensile strength, pounds per square inch.....	50,000 to 60,000	52,000 to 62,000	60,000 to 70,000
Yield point, in pounds per square inch, shall not be less than.....	$\frac{1}{2}$ T.S.	$\frac{1}{2}$ T. S.	$\frac{1}{2}$ T. S.
Elongation per cent. in eight inches shall not be less than.....	26	25	22

5. *Modifications in Elongation for Thin and Thick Material.*—For material less than five-sixteenth inch ($\frac{5}{16}$ "') and more than three-fourths inch ($\frac{3}{4}$ "') in thickness, the following modifications shall be made in the requirements for elongation :

(a) For each increase of one-eighth inch ($\frac{1}{8}$ "') in thickness above three-fourths inch ($\frac{3}{4}$ "'), a deduction of one per cent. (1%) shall be made from the specified elongation.

(b) For each decrease of one-sixteenth inch ($\frac{1}{16}$ "') in thickness below five-sixteenths inch ($\frac{5}{16}$ "'), a deduction of two and one-half per cent. ($2\frac{1}{2}\%$) shall be made from the specified elongation.

(c) For pins made from any of the three classes of steel, the required elongation shall be five per cent. (5%) less than that specified in paragraph No. 4, as determined on a test specimen the centre of which shall be one inch (1") from the surface.

6. *Tensile Tests of Eye-bars.*—Eye-bars shall be of medium steel. Full-sized tests shall show $12\frac{1}{2}$ per cent. elongation in fifteen feet of the body of the eye-bar, and the tensile strength shall not be less than 55,000 pounds per square inch. Eye-bars shall be required to break in the body, but should an eye-bar break in the head and show twelve and one-half per cent. ($12\frac{1}{2}\%$) elongation in fifteen feet and the tensile strength specified, it shall not be cause for rejection, provided that not more than one-third ($\frac{1}{3}$) of the total number of eye-bars tested break in the head.

7. *Bending Tests.*—The three classes of structural steel for bridges and ships shall conform to the following bending tests ; and for this purpose the test specimen shall be one and

site sides of the test specimens shall be the rolled surfaces. Rivet rounds and small rolled bars shall be tested of full size as rolled.

9. *Number of Tensile Tests.*—One tensile-test specimen shall be taken from the finished material of each melt, but in case this develops flaws, or breaks outside of the middle third of its gauged length, it may be discarded and another test specimen substituted therefor.

10. *Test Specimens for Bending.*—One test specimen for bending shall be taken from the finished material of each melt as it comes from the rolls, and for material three-fourths inch ($\frac{3}{4}$ ") and less in thickness this specimen shall have the natural rolled surface on two opposite sides. The bending-test specimen shall be one and one-half inches ($1\frac{1}{2}$ ") wide, if possible, and for material more than three-fourths inch ($\frac{3}{4}$ ") thick the bending-test specimen may be one-half inch ($\frac{1}{2}$ ") thick. The sheared edges of bending-test specimens may be milled or planed.

11. *Annealed Test Specimens.*—Material which is to be used without annealing or further treatment shall be tested for tensile strength in the condition in which it comes from the rolls. Where it is impracticable to secure a test specimen from material which has been annealed or otherwise treated, a full-sized section of the tensile-test specimen length shall be similarly treated before cutting the tensile specimen therefrom.

12. *Yield Point.*—For the purpose of this specification the yield point shall be determined by the careful observation of the drop of the beam or halt in the gauge of the testing machine.

13. *Sample for Chemical Analysis.*—In order to determine if the material conforms to the chemical limitations prescribed in paragraph No. 2 herein, analysis shall be made of drillings taken from a small test ingot.

VARIATION IN WEIGHT.

14. The variation in cross-section or weight of more than $2\frac{1}{2}$ per cent. from that specified will be sufficient cause for rejection,

except in the case of sheared plates, which will be covered by the following permissible variations:

(h) Plates $12\frac{1}{2}$ pounds per square foot or heavier, up to 100 inches wide, when ordered to weight, shall not average more than $2\frac{1}{2}$ per cent. variation above or $2\frac{1}{2}$ per cent. below the theoretical weight. When 100 inches wide and over, 5 per cent. above or 5 per cent. below the theoretical weight.

(i) Plates under $12\frac{1}{2}$ pounds per square foot, when ordered to weight, shall not average a greater variation than the following:

Up to 75 inches wide, $2\frac{1}{2}$ per cent. above or $2\frac{1}{2}$ per cent. below the theoretical weight. 75 inches wide up to 100 inches wide, 5 per cent. above or 3 per cent. below the theoretical weight. When 100 inches wide and over, 10 per cent. above or 3 per cent. below the theoretical weight.

* * * * * * * *

(j) For all plates ordered to gauge there will be permitted an average excess of weight over that corresponding to the dimensions on the order equal in amount to that specified in the following table:

TABLE OF ALLOWANCES FOR OVERWEIGHT FOR RECTANGULAR PLATES
WHEN ORDERED TO GAUGE.

Plates will be considered up to gauge if measuring not over $1/100$ inch less than the ordered gauge.

The weight of 1 cubic inch of rolled steel is assumed to be 0.2833 pound.

Plate 1/4 Inch and over in Thickness.

Thickness of Plate. Inch.	Width of Plate.		
	Up to 75 inches. Per cent.	75 to 100 inches. Per cent.	Over 100 inches. Per cent.
1/4	10	14	18
5/16	8	12	16
3/8	7	10	13
7/16	6	8	10
1/2	5	7	9
9/16	4½	6½	8½
5/8	4	6	8
Over 5/8	3½	5	6½

Plates under 1/4 Inch in Thickness.

Thickness of Plate. Inch.	Width of Plate.	
	Up to 50 inches. Per cent.	50 inches and above. Per cent.
1/8 up to 5/32	10	15
5/32 " 3/16	8½	12½
3/16 " 1/4	7	10

FINISH.

15. Finished material must be free from injurious seams, flaws, or cracks, and have a workmanlike finish.

BRANDING.

16. Every finished piece of steel shall be stamped with the melt number, and steel for pins shall have the melt number stamped on the ends. Rivets and lacing steel, and small pieces for pin plates and stiffeners, may be shipped in bundles, securely wired together, with the melt number on a metal tag attached.

INSPECTION.

17. The inspector representing the purchaser shall have all reasonable facilities afforded to him by the manufacturer to satisfy him that the finished material is furnished in accordance with these specifications. All tests and inspections shall be made at the place of manufacture prior to shipment.

STRUCTURAL STEEL FOR BUILDINGS.

PROCESS OF MANUFACTURE.

1. Steel may be made by either the open-hearth or Bessemer process.

CHEMICAL PROPERTIES.

2. Each of the two classes of structural steel for buildings shall not contain more than 0.10 per cent. of phosphorus.

PHYSICAL PROPERTIES.

3. *Classes.*—There shall be two classes of structural steel for buildings, namely, RIVET STEEL and MEDIUM STEEL which shall conform to the following physical qualities:

4. *Tensile Tests.*

	Rivet Steel.	Medium Steel.
Tensile strength, pounds per square inch.....	50,000 to 60,000	60,000 to 70,000
Yield point, in pounds per square inch shall not be less than.....	$\frac{1}{2}$ T. S.	$\frac{1}{2}$ T. S.
Elongation, per cent. in eight inches shall not be less than	26	22

5. *Modifications in Elongation for Thin and Thick Material.*—

For material less than five-sixteenths inch ($\frac{5}{16}$ "), and more than three-fourths inch ($\frac{3}{4}$ ") in thickness, the following modifications shall be made in the requirements for elongation:

(a) For each increase of one-eighth inch ($\frac{1}{8}$ ") in thickness above three-fourths inch ($\frac{3}{4}$ "), a deduction of one per cent. (1%) shall be made from the specified elongation.

(b) For each decrease of one-sixteenth inch ($\frac{1}{16}$ ") in thickness below five-sixteenths inch ($\frac{5}{16}$ ") a deduction of two and one-half per cent. ($2\frac{1}{2}$ %) shall be made from the specified elongation.

(c) For pins the required elongation shall be five per cent. (5%) less than that specified in paragraph No. 4, as determined on a test specimen the centre of which shall be one inch (1") from the surface.

6. *Bending Tests.*—The two classes of structural steel for buildings shall conform to the following bending tests; and for this purpose the test specimen shall be one and one-half inches ($1\frac{1}{2}$ ") wide, if possible, and for all material three-fourths inch ($\frac{3}{4}$ ") or less in thickness the test specimen shall be of the same thickness as that of the finished material from which it is cut, but for material more than three-fourths inch ($\frac{3}{4}$ ") thick the bending-test specimen may be one-half inch ($\frac{1}{2}$ ") thick:

Rivet rounds shall be tested of full size as rolled.

(d) Rivet steel shall bend cold 180° flat on itself without fracture on the outside of the bent portion.

(e) Medium steel shall bend cold 180° around a diameter equal to the thickness of the specimen tested, without fracture on the outside of the bent portion.

TEST PIECES AND METHODS OF TESTING.

7. *Test Specimen for Tensile Test.*—The standard test specimen of eight-inch (8") gauged length shall be used to determine the physical properties specified in paragraphs Nos. 4 and 5. The standard shape of the test specimen for sheared plates shall be as shown by the following sketch:

11. *Yield Point.*—For the purposes of this specification, the yield point shall be determined by the careful observation of the drop of the beam or halt in the gauge of the testing machine.

12. *Sample for Chemical Analysis.*—In order to determine if the material conforms to the chemical limitations prescribed in paragraph No. 2 herein, analysis shall be made of drillings taken from a small test ingot.

VARIATION IN WEIGHT.

13. The variation in cross-section or weight of more than $2\frac{1}{2}$ per cent. from that specified will be sufficient cause for rejection, except in the case of sheared plates, which will be covered by the following permissible variations:

(g) Plates $12\frac{1}{2}$ pounds per square foot or heavier, up to 100 inches wide, when ordered to weight, shall not average more than $2\frac{1}{2}$ per cent. variation above or $2\frac{1}{2}$ per cent. below the theoretical weight. When 100 inches wide and over 5 per cent. above or 5 per cent. below the theoretical weight.

(h) Plates under $12\frac{1}{2}$ pounds per square foot, when ordered to weight, shall not average a greater variation than the following:

Up to 75 inches wide, $2\frac{1}{2}$ per cent. above or $2\frac{1}{2}$ per cent. below the theoretical weight. 75 inches wide up to 100 inches wide, 5 per cent. above or 3 per cent. below the theoretical weight. When 100 inches wide and over 10 per cent. above or 3 per cent. below the theoretical weight.

* * * * *

(i) For all plates ordered to gauge, there will be permitted an average excess of weight over that corresponding to the dimensions on the order equal in amount to that specified in the following table:

TABLE OF ALLOWANCES FOR OVERWEIGHT FOR RECTANGULAR PLATES
WHEN ORDERED TO GAUGE.

Plates will be considered up to gauge if measuring not over 1/100 inch less than the ordered gauge.

The weight of 1 cubic inch of rolled steel is assumed to be 0.2833 pound.

Plates 1/4 Inch and over in Thickness.

Thickness of Plate. Inch.	Width of Plate.		
	Up to 75 inches. Per cent.	75 to 100 inches. Per cent.	Over 100 inches. Per cent.
1/4	10	14	18
5/16	8	12	16
3/8	7	10	13
7/16	6	8	10
1/2	5	7	9
9/16	4½	6½	8½
5/8	4	6	8
Over 5/8	3½	5	6½

Plates under 1/4 Inch in Thickness.

Thickness of Plate. Inch.	Width of Plate.	
	Up to 50 inches. Per cent.	50 inches and above. Per cent.
1/8 up to 5/32	10	15
5/32 " 3/16	8½	12½
3/16 " 1/4	7	10

FINISH.

14. Finished material must be free from injurious seams, flaws, or cracks, and have a workmanlike finish.

BRANDING.

15. Every finished piece of steel shall be stamped with the melt or blow number, except that small pieces may be shipped in bundles securely wired together with the melt or blow number on a metal tag attached.

INSPECTION.

16. The inspector representing the purchaser shall have all reasonable facilities afforded to him by the manufacturer to satisfy him that the finished material is furnished in accordance with these specifications. All tests and inspections shall be made at the place of manufacture, prior to shipment.

STEEL FORGINGS.

PROCESS OF MANUFACTURE.

1. Steel for forgings may be made by the open-hearth, crucible, or Bessemer process.

CHEMICAL PROPERTIES.

2. There will be four classes of steel forgings which shall conform to the following limits in chemical composition:

	Forgings of Soft or Low Carbon Steel.	Forgings of Carbon Steel not Annealed.	Forgings of Carbon Steel, Oil-tempered or Annealed.	Forgings of Nickel Steel Oil-tempered or Annealed.
	Per cent.	Per cent.	Per cent.	Per cent.
Phosphorus shall not exceed....	0.10	0.06	0.04	0.04
Sulphur " " " "	0.10	0.06	0.04	0.04
Nickel.....	3.00-4.00

PHYSICAL PROPERTIES.

3. *Tensile Tests.*—The minimum physical qualities required of the different sized forgings of each class shall be as follows:

Tensile Strength.	Yield Point.	Elongation in $\frac{1}{2}$ ".	Contraction of Area.	
Pounds per Square inch.		Per cent.	Per cent.	
58,000	29,000	28	35	<i>Soft Steel or Low Carbon Steel.</i> For solid or hollow forgings, no diameter or thickness of section to exceed 10".
				<i>Carbon Steel Not Annealed.</i> For solid or hollow forgings, no diameter or thickness of section to exceed 10".
				<i>Carbon Steel Annealed.</i> For solid or hollow forgings, no diameter or thickness of section to exceed 10".
80,000	40,000	22	35	For solid forgings, no diameter to exceed 20" or thickness of section 15".
75,000	37,500	23	35	For solid forgings, over 20" diameter.
70,000	35,000	24	30	
				<i>Carbon Steel, Oil-tempered.</i> For solid or hollow forgings, no diameter or thickness of section to exceed 3".
90,000	55,000	20	45	

Tensile Strength. Pounds per Square inch.	Elastic Limit.	Elongation in $\frac{3}{8}$ "	Contraction of Area. Per cent.
85,000	50,000	22	45
80,000	45,000	23	40
80,000	50,000	25	45
80,000	45,000	25	45
80,000	45,000	24	40
95,000	65,000	21	50
90,000	60,000	22	50
85,000	55,000	24	45

Carbon Steel, Oil-tempered.

For solid forgings of rectangular sections not exceeding 6" in thickness or hollow forgings, the walls of which do not exceed 6" in thickness.

For solid forgings of rectangular sections not exceeding 10" in thickness or hollow forgings, the walls of which do not exceed 10" in thickness.

Nickel Steel Annealed.

For solid or hollow forgings, no diameter or thickness of section to exceed 10".

For solid forgings, no diameter to exceed 20" or thickness of section 15".

For solid forgings, over 20" diameter.

Nickel Steel, Oil-tempered.

For solid or hollow forgings, no diameter or thickness of section to exceed 3".

For solid forgings of rectangular sections not exceeding 6" in thickness or hollow forgings, the walls of which do not exceed 6" in thickness.

For solid forgings of rectangular sections not exceeding 10" in thickness or hollow forgings, the walls of which do not exceed 10" in thickness.

4. *Bending Test.*—A specimen one inch by one-half inch ($1'' \times \frac{1}{2}''$) shall bend cold 180° without fracture on outside of bent portion as follows:

Around a diameter of $\frac{1}{2}''$, for forgings of soft steel.

Around a diameter of $1\frac{1}{2}''$, for forgings of carbon steel not annealed.

Around a diameter of $1\frac{1}{2}''$, for forgings of carbon steel annealed, if 20" in diameter or over.

Around a diameter of 1", for forgings of carbon steel annealed, if under 20" diameter.

Around a diameter of 1", for forgings of carbon steel oil-tempered.

Around a diameter of $\frac{1}{2}$ " , for forgings of nickel steel annealed.
 Around a diameter of 1" , for forgings of nickel steel oil-tempered.

TEST PIECES AND METHODS OF TESTING.

5. *Test Specimen for Tensile Test.*—The standard turned test specimen, one-half inch ($\frac{1}{2}$ ") diameter and two-inch (2") gauged length shall be used to determine the physical properties specified in paragraph No. 3. It is shown in the following sketch.

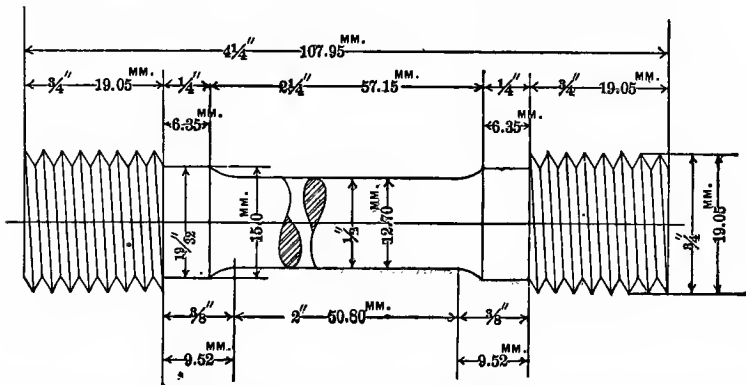

6. *Number and Location of Tensile Specimens.*—The number and location of test specimens to be taken from a melt, blow, or a forging shall depend upon its character and importance and must therefore be regulated by individual cases. The test specimens shall be cut cold from the forging or full-sized prolongation of same parallel to the axis of the forging and half way between the centre and outside, the specimens to be longitudinal, *i.e.*, the length of the specimen to correspond with the direction in which the metal is most drawn out or worked. When forgings have large ends or collars, the test specimens shall be taken from a prolongation of the same diameter or section as that of the forging back of the large end or collar. In the case of hollow shafting, either forged or bored, the specimen shall be taken within the finished section prolonged, half way between the inner and outer surface of the wall of the forging.

7. *Test Specimen for Bending.*—The specimen for bending test one inch by one-half inch ($1'' \times \frac{1}{2}''$) shall be cut as specified in paragraph No. 6. The bending test may be made by pressure or by blows.

8. *Yield Point.*—The yield point specified in paragraph No. 3 shall be determined by the careful observation of the drop of the beam or halt in the gauge of the testing machine.

9. *Elastic Limit.*—The elastic limit specified in paragraph No. 3 shall be determined by means of an extensometer, which is to be attached to the test specimen in such manner as to show the change in rate of extension under uniform rate of loading, and will be taken at that point where the proportionality changes.

10. *Sample for Chemical Analysis.*—Turnings from the tensile specimen or drillings from the bending specimen or drillings from the small test ingot, if preferred by the inspector, shall be used to determine whether or not the steel is within the limits in chemical composition specified in paragraph No. 2.

FINISH.

11. Forgings shall be free from cracks, flaws, seams, or other injurious imperfections, and shall conform to dimensions shown on drawings furnished by the purchaser, and be made and finished in a workmanlike manner.

INSPECTION.

12. The inspector representing the purchaser shall have all reasonable facilities afforded to him by the manufacturer to satisfy him that the finished material is furnished in accordance with these specifications. All tests and inspections shall be made at the place of manufacture prior to shipment.

STANDARD SPECIFICATIONS FOR GRAY IRON
CASTINGS.*

1. Unless furnace iron, dry sand, or loam moulding, or subsequent annealing is specified, all gray iron castings are understood to be of cupola metal; mixtures, moulds, and methods of preparation to be fixed by the founder to secure the results desired by purchaser.

2. All castings shall be clean, free from flaws, cracks, and excessive shrinkage. They shall conform in other respects to whatever points may be specially agreed upon.

3. When the castings themselves are to be tested to destruction, the number selected from a given lot and the tests they shall be subjected to are made a matter of special agreement between founder and purchaser.

4. Castings made under these specifications, the iron in which is to be tested for its quality, shall be represented by at least three test bars cast from the same heat.

5. These test bars shall be subjected to a transverse breaking test, the load applied at the middle with supports 12 inches apart. The breaking load and deflection shall be agreed upon specially on placing the contract, and two of these bars shall meet the requirements.†

6. A tensile-strength test may be added, in which case at least three bars for this purpose shall be cast with the others in the same moulds respectively. The ultimate strength shall also be agreed upon specially before placing the contract, and two of the bars shall meet the requirements.

7. The dimensions of the test bars shall be as given herewith. There is only one size for the tensile bar and three for

* Adopted, 1901, by American Foundrymen's Association.

† The remarkably wide range of values, for the ultimate strength and modulus of rupture which are really good for the various classes of iron, precludes the giving of definite upper limits in the specifications. It will therefore remain a matter of mutual agreement in each case, the requirements of service and price per pound paid regulating the mixtures which can be used.

the transverse. For the light- and medium-weight castings the $1\frac{1}{2}$ -inch D. bar is to be used, heavy castings the 2-inch D., and chilling irons the $2\frac{1}{2}$ -inch D. test bar.

STEEL SOCKET FOR TENSILE TEST OF CAST IRON.

Two required.

Test pieces should fit in loosely.

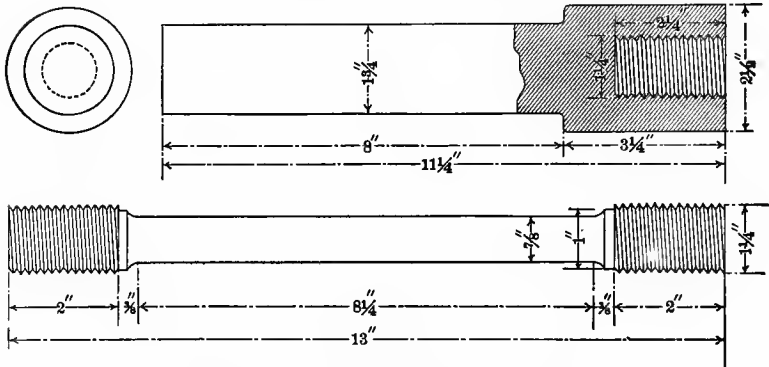

STANDARD TEST BAR FOR CAST IRON.

Tensile Test.

Cross-section equals $\frac{1}{4}$ square inch.

8. Where the chemical composition of the castings is a matter of specification in addition to the physical tests, borings shall be taken from all the test bars made, well mixed, and any required determination, combined carbon and graphite alone excepted, made therefrom.*

9. Reasonable facilities shall be given the inspectors to satisfy themselves that castings are being made in accordance with specifications, and, if possible, tests shall be made at the place of production prior to shipment.

Steel for electrical purposes, especially, should be soft and should partake largely of the properties of wrought iron. Its carbon should be low, the manganese quite low and usually, it is

* There should really be no necessity for this test, for the requirements of the physical tests presuppose a given chemical composition. It may, however, sometimes be expedient to know the total carbon, silicon, sulphur, manganese, and phosphorus of a casting to insure good service conditions.

thought, the phosphorus moderately low. Carbon ranges, with various makes, from 0.8 to 0.012, manganese from 0.30 to 0.35, phosphorus from 0.04 to 0.08, and sulphur about 0.04 per cent. Manganese increases hysteresis losses and phosphorus increases electrical resistance. Precise composition is dependent on the use contemplated.

TAYLOR-WHITE PROCESS (Text, p. 270).

[Journal Franklin Institute, February, 1903.]

Report of the Committee on the Invention of White and Taylor.
(Abstract.)

There are two distinct classes of tool-steel, namely, carbon and air or self-hardening. The latter brand, the result of Mushet's work, has completely replaced the carbon steel for roughing, its comparative efficiency approximately being 1.5 to 1.0. Mushet discovered that by the addition of manganese and tungsten to tool-steel it maintained its cutting edge at much higher temperatures and consequently much higher speeds were possible.

* * * * *

It must be understood at this point that all air-hardening steel manufactured up to this time was hardened by heating to a cherry-red and either allowed to cool gradually or in a blast of air. Users were invariably cautioned against overheating, cherry-red being specified as the desired temperature.

* * * * *

Messrs. Taylor & White say in part: "Our invention relates to the manufacture of tools for cutting metals or similar uses where the tool is highly heated in performing its work, the object of our invention being to provide a tool capable of working at higher temperature, and consequently doing more work in a given time than the tools as heretofore made." The above statements make it very clear that the tool is adapted to *roughing work only*, and unless sufficient speed can be obtained, no gain in output can be had. We wish to make this point perfectly clear.

Again, on the first page of the patent papers (Pars. 65-90), we find a general statement of the invention which may be worth quoting: "Our invention is based on our discovery that while it is true tools made of air-hardening steels all deteriorate at temperatures in excess of a bright cherry-red (though it must be understood, not all at the same temperature), it is also true that when air-hardening steels are made with certain constituents in ascertained proportions this deterioration only prevails during a limited range of temperatures above the bright cherry-red; that is to say, from about 1,550° F. to about 1,700° F. (corresponding to a light-salmon color), and on our further discovery that above this range of temperature, which we will call the 'breaking-down point,' and from 1,725° F. up to a temperature at which the steel softens or crumbles when touched with a rod (approximately 1,900° or 2,000° F.), the efficiency of tools of such special steels—that is to say, their cutting speeds, and also their uniformity in efficiency—is greatly increased and largely so in proportion to the degree of heat to which they are raised. This is so much the case that their cutting speed may be stated to be from one and a half to two and a half times that of the tool heated as heretofore, to a temperature below the breaking-down point."

The accompanying curve of temperature and cutting speed (page 711) shows very clearly in a graphical manner the principle of the Taylor-White discovery, and also the reason why a cherry-red was deemed best heretofore, as the curve falls off at this point.

In order to obtain a suitable steel for the Taylor-White treatment it is necessary that it should be compounded with chromium in the proportion of at least one-half of 1 per cent. and another or other members of the commercially available members of the chromium group of metals in the proportion of at least 1 per cent.; that is to say, with either tungsten or molybdenum in the proportion of at least 1 per cent. They also state that materially better results are obtained in some cases by increasing these proportions. The relative value of the various members of the chromium

group are carefully considered in the patent papers, and it is interesting to note that the percentage of carbon seems to have

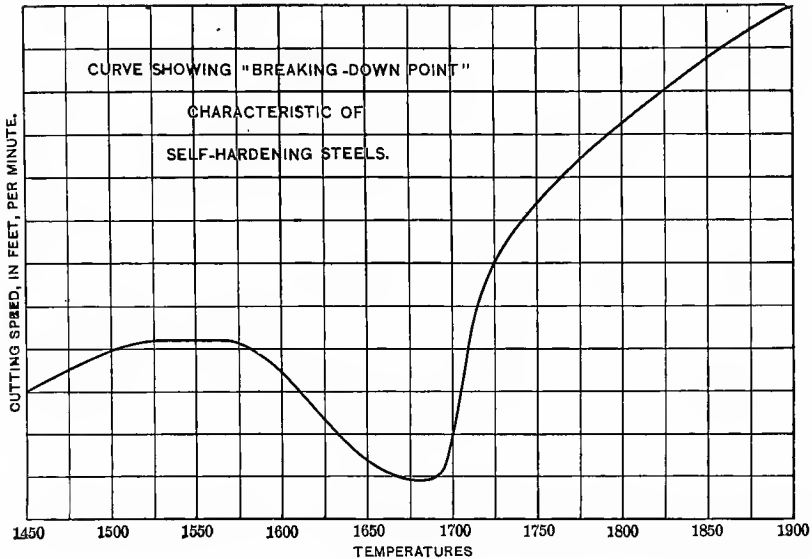

little or no effect on the results, steels containing from 85 C. to 200 C. having the same efficiency.

We quote from the patent papers, page 2, paragraph 50: "We do not feel able to state with certainty the chemical and molecular changes which occur in steels of this composition when heated above the breaking-down point, and to the high-heat characteristic of our process, but will mention as one characteristic change due to our treatment that the tools after exposure to the high heat show, by analysis, a *smaller* percentage of carbide of chromium than existed in the steels before such treatment; for example, in steels containing $1\frac{1}{2}$ per cent. chromium and $\frac{7}{10}$ per cent. carbide of chromium the tool after treatment contained but $\frac{2}{10}$ per cent. of carbide of chromium, and in steels containing $\frac{3}{4}$ per cent. of chromium and $\frac{9}{10}$ of carbide of chromium the treated steel contained but $\frac{3}{10}$ per cent. of carbide of chromium.

“Again, air-hardening steels of this composition, like air-hardening steels in general, possess in their normal condition the characteristically fine velvety grain when fractured. The higher range of temperature necessary in our treatment has a very noticeable tendency to change the structure of the metal and to give a non-velvety appearance and coarser grain, frequently interspersed with sparkling grains. When treated with the higher heats and to obtain the best results, the steel of the tools shows under the microscope a distinctly large-grained structure, in many cases intercepted with austenite or microconstituent of steel discovered by Osmond, the chemical composition of which is unknown, and which, according to the best authorities, has never been met with in the industrial treatment of steel.”

The question of cooling the tool is considered in detail, different methods being adopted for various duties. They may be in general stated, however, as follows: The tool is cooled rapidly from the high heat to a point below the breaking-down temperature in a lead-bath, then slowly in the air or lime, etc., as the case may be. It is very essential that at no time the temperature should rise, as in such a case the tool would be seriously impaired. After the tool has cooled off, its efficiency is found to be further increased by subjecting it to what is termed the low heat for about ten minutes, this temperature ranging from 700° F. to 1,200° F. One of the chief claims made by Messrs. Taylor & White is the great uniformity obtained by their process, which makes it possible to run every tool to a very high efficiency. This uniformity is obtained by the apparatus employed, by means of which remarkably close temperatures can be ascertained. The tool, after being forged, is placed in a coke furnace, where it is heated gradually to a high heat, the latter being designated as the point at which the steel crumbles when tapped with a rod. As the tool is incandescent at this point, it is necessary that the operator wear colored glasses while testing for heat.

After heating, the tool is rapidly drawn from the furnace

and plunged into a lead-bath, which is maintained at a certain temperature by a very ingenious method.

* * * * *

In order to verify the statements made in the patent papers with regard to increased efficiency at high speeds, and to investigate the apparatus above referred to, your Committee visited the Bethlehem Steel Works on December 20 and 21 in 1901. Various brands of air-hardening steel were purchased and hardened in the presence of the Committee, according to the manufacturers' instructions. These tools were forwarded to Bethlehem and ground to the standard angles as given below. All the tools that were tested were brands that were on the market at the time the Taylor-White patents were granted.

* * * * *

It must be understood that all the tools compared with the Taylor-White in these tests were tools that were on the market at the time of the invention.

An examination of the tests on the 86° C. hammered forging shows that the relative efficiency of the treated tool and best untreated tool is 11 to 3 or more than 3.5 to 1, for the soft forging (10 carbon) 156 to 70 or 2.2 to 1, and for the cast iron 70 to 55 or slightly less than 1.3 to 1. These figures show that for steel the efficiency is much greater for hard forgings than for soft, but even in the latter case exceeds two to one, while as we might expect the saving on cast iron is much less, being about 1¼ to 1. On hard castings, however, the gain is much more, often reaching 2 to 1, and on this account it is well adapted to certain work.

* * * * *

Reference to the table shows a cutting speed of 156 feet per minute, with $\frac{3}{16}$ -inch depth of cut and $\frac{1}{16}$ -inch feed. This tool was removing metal at the rate of 353 pounds per hour and was *red-hot* $\frac{1}{16}$ inch from the point. The color was distinctly visible in the daylight, no stronger proof being needed of the high heat at which these tools maintain their cutting edge. At the end of twenty minutes the edge of the tool was carefully examined

Tool-Steel Tested.	Date.	Exp. No.	Forging No.	Feed.	Depth of Cut.	Cutting Speed Aimed at.	Duration of Cut.	Average Cutting Speed Obtained.	Condition of Tool at End of Run.	Remarks.
T.W.H. 2313...	Dec. 19	1	7238 C	Inch. 1/16	Inch. 3/16	11	20	11	Fair Point	Inch. 5/8 travel
Mushet	"	2	"	1/16	3/16	5	(*13 3/8)	5	Gone	1 1/8 "
"	"	3	"	1/16	3/16	3 1/2	(†12 3/8)	3 1/2	com- pletely	1 1/8 "
Sanderson	"	4	"	1/16	3/16	3 1/2	20	3 1/2	Gone	1 7/8 "
Boreas	"	5	"	1/16	3/16	4 1/2	20	4 1/2	"	2 "
Mushet	"	16	"	1/16	3/16	3	4	3	"	"
Baeburn	"	17	"	1/16	3/16	3	20	3	Fair	1 3/4 "
Mushet	"	18	"	1/16	3/16	3	20	3	Gone	1 3/4 "
T.W.M.E. 2806	Dec. 20	6	19788 B†	1/16	3/16	140	20	140	Good	39 3/4 "
Sanderson	"	8	"	1/16	3/16	72	20	72	Fair	19 3/8 "
Mushet	"	9	"	1/16	3/16	72	1 3/4	72	Gone	1 3/8 "
Boreas	"	10	"	1/16	3/16	72	6 1/2	72	"	6 1/8 "
Mushet	"	11	"	1/16	3/16	60	19	60	"	15 3/4 "
Sanderson	"	17	"	1/16	3/16	82	19 1/4	82	"	22 1/2 "
Benj. Atha	"	13	"	1/16	3/16	82	13	82	"	15 1/4 "
T.W.M.E. 2757.	"	14	"	1/16	3/16	156	20	156	Good	40 1/2 †
T.W.B. o.3.....	"	19	1506 A	1/16	3/16	70	20	70	Good	16 1/2 "
Boreas	"	20	"	1/16	3/16	55	20	55	Good	12 3/4 "
"	"	21	"	1/16	3/16	60	3.8	—	Gone	2 1/8 "
Mushet	"	22	"	2/16	3/16	50	20	50	"	11 1/8 "
Benj. Atha	"	23	"	1/16	3/16	50	20	50	Good	11 3/8 "
T.W.B. o.3.....	"	24	"	1/16	3/16	70	20	70	"	16 1/2 "
Benj. Atha.....	"	25	"	1/16	3/16	55	3 1/2	—	Gone	2 1/8 "

* Examination of tool showed that it failed long before end of test.
 † Point of tool red-hot for 13 minutes.
 ‡ Point of tool red-hot for 15 minutes.

CHEMICAL COMPOSITION OF ABOVE FORGINGS.

	Bar No. 7238 C'.	Bar No. 19788 B'.	No. 1506 A.	
Carbon.....	.876	.105	Total 3.854	
			Graphite 2.948	
Manganese ..	.62	.36		Combined .906
Silicon.....	.24	.025		
Phosphorus..	.025	.023		
Sulphur.....	.028	.035		

ANGLES OF TOOLS TESTED.

	Hard Bar.	Soft Bar.	Cast-iron.
Clearance....	6°	6°	6°
Front rake...	5°	8°	14°
Side rake.....	9°	12°	18°

with a magnifying-glass and found to be perfect. In fact, the original grinding-marks could still be detected; consequently we see that the claims made by the inventors regarding increased efficiency for roughing work are just, so far as the brands of steel we compared are concerned.

INDEX.

	ART.	PAGE
Admiralty tests.....	319	659
Age, effect upon metals.....	291	576
Air hoists.....	96	138
supply.....	94	131
Akerman's researches on blast furnace.....	80	109
Alloys.....	2	4
defined.....	15	14
qualities.....	15	14
Analyzing ores.....	56	80
Assaying ores.....	57	81
Beams, elastic resistance.....	268	496
experiments.....	269	502
formulas.....	264	488
mills.....	126	183
sections.....	266	493
specifications.....	317	658
sections for uniform strength.....	267	495
strength; constants.....	270	505
methods of resistance.....	262	485
rupture, theory.....	263	486
tables; loads on.....	271	509
Bell's researches on blast furnaces.....	80	109
Bessemer steel.....	160	241
apparatus.....	160	241
dephosphorization of.....	164	259
qualities of.....	165	261
plant.....	160	241
process of manufacture of.....	162	254
properties of.....	163	258
and Siemens-Martin, compared.....	239	427
Blast furnace [<i>See</i> Furnace].		
Bloomary.....	107	151
American.....	108	152
Blowing engines.....	93	130
Boiler flues.....	254	463
plate.....	238	426
shells.....	247	448
stayed surfaces.....	246	445
steels.....	237	423
work; specifications.....	305	631
Boiling or puddling.....	115	161
Book-keeping at blast furnaces.....	102	142
Bridge-work.....	308	642
specifications.....	307	633
steels.....	237	423

	ART.	PAGE
Calcination of ores.....	23, 67	26, 91
Carburization of iron.....	153	221
Casting iron and steel.....	90	124
Castings, steel.....	242	431
Cast iron [<i>See</i> Iron].		
Cast steel [<i>See</i> Steel].		
Catalan forge.....	34	41
furnaces.....	107	151
American.....	108	152
Cementation steel.....	154	223
Chain iron.....	231	409
Chrome iron ores.....	50	74
steel.....	167, 182	266, 307
Cinder or slag.....	89	122
Clay iron ores.....	48	71
Cold-rolling.....	302	615
Columns, flexure.....	256	466
formulas.....	258	468
long.....	257	466
struts.....	255	465
Compression [<i>See</i> Strength, Compressive].		
hardening by.....	191	328
Continuous mills.....	127	183
Cooper lines.....	321	661
Corrosion of iron and steel.....	192, 291	328, 576
Crucible steel.....	156	227
Crystallization.....	292	578
Curves of resistance; equations of.....	202	346
Cylinders, cast-iron.....	248	450
flues of boilers.....	254	463
shells of boilers.....	247	448
Decarbonization process.....	111	157
of cast iron.....	166	263
Density of metals.....	11	8
Dephosphorization of steel.....	164	259
Dressing ores.....	63	89
Ductility of metals.....	12	9
Durability of iron and steel.....	193	331
Egyptian metallurgy.....	30	33
Elastic limit [<i>See</i> Strain Diagrams].	301	610
normal, variation of.....	298	600
orthogonal strains.....	300	608
overstrain, evidence of.....	299	604
series of.....	204	347
and set.....	297	549
resistance, theory.....	268	496
Emery's testing machine.....	218	372
Engineer, requirements of the.....	6	6
Engines, blowing.....	93	130
Equating curves of resistance.....	202	346
Exposure of metals to weather.....	291	376
weathering ores.....	64	89
Fairbanks' transverse testing machine.....	218a, 220	376
Flexure [<i>See</i> Strength, transverse; Columns].		

INDEX.

717

	ART.	PAGE
Floors and girders	317	658
Flow of metals [<i>See</i> Elastic Limit, Rolling, Strain Diagrams] ...	293	585
Flues, strength of	254	463
Fluxes [<i>See</i> Furnace, Metallurgy, Ore, Ore-Reduction]	25	27
Fluxing steels	159	239
Forge, Catalan	34	41
processes	112	156
Fuels	26	27
Furnace [<i>See</i> Iron, Metallurgy, Metals, Ore, Ore-Reduction].		
Akerman's, Bell's and others' researches on blast	80	109
blast	34	41
air supply	94	131
Akerman's, Bell's and others' researches	80	109
book-keeping at	102	142
casting at	90	124
changes at forge	81	113
charge, making up	71, 74	95, 100
cinder from	89	122
cost of	77	106
form of	75	100
heights of	84	115
hot, blast stoves, Whitwell's, at	91, 92	125, 129
location of	103	144
losses at	87	121
managing	105	147
performance of	88	122
products ; grades of iron	106	150
proportions of	75	100
putting in blast	78	107
record of performance of	88	102
researches, various	80	109
shape of	76	104
size of	83	114
slag from	89	122
temperatures of	85	115
blast of	86	117
value of	104	146
bloomary	107	151
blowing engines for blast furnaces	93	130
book-keeping for blast furnaces	102	142
Catalan	107	151
American	108	152
forge	34	41
changes in blast	81	173
Siemens' process and	109	153
Gill's testing machine	216	370
Girders and floors	317	658
Grading ores	66	91
Greek metallurgy	30	33
Hammering Iron	121	176
Hardening [<i>See</i> Arts. 189-191 ; pp. 323-328].		
Hardness of metals	9	8
Heat, changes, effect on metals	288	566
conductivity	10	8
expansion [<i>See</i> Arts. 17-19 ; pp. 17-19].		
latent	14	12

	ART.	PAGE
Heat, specific, of metals.....	16	25
strength affected by.....	285	550
experiments by Sandberg, Styffe and others	286	559
stress produced by.....	289	568
effect of sudden change of temperature.....	290	568
Hematite, brown.....	46	67
red.....	45	64
Hewitt's "three-high" mill.....	132	186
Hoists.....	95	134
air.....	96	138
steam.....	97	139
Impact tests of iron.....	219	375
Inertia, geometrical moment of.....	259	475
practical applications.....	260	477
Ingot iron and steel.....	235	417
Inspectors' duties.....	322	662
Iron [<i>See</i> Furnace, Metallurgy, Metals, Ore, Ore-Reduction, Specification, Steel, Strength].		
anthracite.....	175	287
carbonization of.....	153	221
chain.....	231	409
charcoal.....	175	287
chemical composition of.....	171	280
properties of [<i>See</i> properties, <i>below</i>].		
tests of.....	184	313
coke.....	175	287
cold-rolling.....	302	615
commercial.....	169	272
compression, hardening by.....	191	328
construction.....	309, 316	645, 655
durability of.....	193	331
exposure of.....	170, 291	273, 476
ingot.....	235	417
meteoric.....	42	60
piling.....	234	416
preservation of.....	194	332
paints for.....	195	333
special compositions for.....	196	335
steam boilers.....	197	335
properties, chemical and physical [<i>See</i> Table of Contents, Chap. VIII., Arts. 169-197, pp. 272-337].		
pure.....	169	272
pyrites.....	49	73
reworking.....	234	416
rolled [<i>See</i> Iron, Wrought, <i>below</i>].		
"short".....	306	632
telluric.....	43	61
Iron, Cast [<i>See</i> Iron].		
analyses of.....	172	282
ordnance.....	173	285
cold-blast.....	174	287
cylinders.....	248	450
decarbonization of.....	166	263
grades of.....	106	150
hot-blast.....	174	287
malleableized.....	145	205
ordnance.....	173	285
physical properties of.....	186	316

	ART.	PAGE
Iron, cast, strain diagrams of.....	245	444
compressive.....	251	468
tenacity of.....	243	439
Iron, wrought [<i>See</i> Iron, Iron, cast].		
analyses of.....	176	293
ancient.....	28	32
boiling and puddling.....	115	161
characteristics of.....	110	155
cold rolling.....	302	615
compressive strength of.....	253	462
continous mills for.....	127	183
cooling, rate of.....	134	189
decarbonizing processes.....	111	155
drawing.....	142	201
wire.....	138	196
resistance.....	140	199
draw-plates for wire.....	139	198
forge process of making.....	112	156
hammering.....	121	176
Hewitt's mill.....	132	186
mills, beam.....	126	183
continous.....	127	183
distribution of men at.....	131	186
Hewitt's.....	132	186
rail.....	126	183
reversing.....	139	185
rolling [<i>See</i> rolling, <i>below</i>].		
three-high.....	129	184
universal.....	128	183
mill-work.....	120	173
plate [<i>See</i> sheet, <i>below</i>].		
specifications for.....	315	653
puddling.....	35	44
balling.....	119	172
machines for.....	118	166
methods of.....	117	165
processes.....	114	158
theory of.....	116	162
rolled iron.....	136	192
cold-rolled.....	302	615
shapes of.....	137	193
designing.....	144	204
peculiar.....	143	203
rolling [<i>See</i> mills, <i>above</i>].....	123	179
effect on strength of.....	142	201
power required for.....	133	188
rolls.....	124	179
cooling.....	134	189
efficacy of.....	135	190
roll trains.....	125	182
Russian sheet iron.....	149	209
shapes of.....	137	193
designing.....	144	204
peculiar.....	143	203
wire [<i>See</i> <i>below</i>].		
sheet, Russian.....	149	209
tin plate.....	146	206
making.....	147	208
weights of.....	148	208

	ART.	PAGE
Iron, wrought, wire drawing.....	138	196
draw plates for.....	139	198
effect on strength.....	142	201
gauges.....	141	201
resistance of.....	140	199
Lustre of metals.....	11	8
Latent heat.....	14	12
Magnetic ores.....	44	62
Malleability of metals.....	12	9
Malleableized cast iron.....	145	205
Metallurgy [<i>See</i> Table of Contents, Chaps. II., III., Arts. 20-40, pp. 21-56; <i>also</i> Furnace, Iron, Metals, Ore, Ore- reduction, Steel].		
American.....	37	45
calcination.....	23	26
Catalan forge.....	34	41
defined.....	22	23
direct processes of.....	33	37
early ideas of.....	20	21
methods of.....	20, 32	32, 35
Egyptian.....	31	34
epochs in.....	36	45
forge, Catalan.....	34	41
processes.....	112	156
fluxes.....	25	27
fuels.....	26	29
Greek.....	30	33
iron-works in New England.....	38	49
Middle States.....	39	52
puddling.....	35	44
and balling.....	119	172
machines.....	118	166
methods of.....	117	165
processes of.....	114	158
theory of.....	116	162
roasting.....	23	26
smelting.....	24	27
Metallurgy, statistics.....	40	56
Metals [<i>See</i> Iron, Steel, Ore, Metallurgy, Strain Diagrams].		
compared with other materials.....	1	3
conductivity for heat.....	10	8
defined.....	3	4
density.....	11	8
ductility.....	12	9
expansion of.....	17	17
application of principle.....	18	19
force of.....	19	19
flow of.....	203	585
hardness of.....	9	8
lustre of.....	11	8
malleability of.....	12	9
qualities, special.....	7	7
specific heat of.....	16	15
strength.....	2	3
tenacity of.....	8	7
Meteoric iron.....	42	60

	ART.	PAGE
Mills, beam	126	183
continuous	127	183
distribution of men at	131	186
Hewitt's	132	186
rail	126	183
reversing	130	185
rolling [<i>See</i> Iron, wrought].	123	179
three-high	129	184
universal	128	183
Mill-work	120	173
Moment of inertia, geometrical	259	475
practical applications	260	477
Mushet's classification of ores	59	82
Nickel steels	241	431
Nuts, resistance to shearing	174	521
Olsen's testing-machine	217	371
Open-hearth steels	157	213
Ore [<i>See</i> Table of Contents, Chap. IV., Arts. 41-64, pp. 58-89, Furnace, Iron, Metallurgy, Metals].		
analyzing	56	80
artificial	53	78
assaying	57	81
brown hematite	46	67
chrome iron	50	73
classification	41	58
Mushet's	59	82
clay iron ore	48	71
commercial values of	62	87
deleterious elements in	54	78
distribution of	5	6
dressing	63	89
grading	66	91
hematite, brown	46	67
red	45	64
iron pyrites	49	73
magnetic	44	62
meteoric iron	42	60
Mushet's classification of	59	82
spathic	47	70
telluric	43	61
titaniferous	51	76
value of	55	80
commercial	62	87
determination of	58	82
intrinsic	61	86
relative	60	84
weathering	64	89
Ore-reduction [<i>See</i> Table of Contents, Chap. V., Arts. 65-109, pp. 91-153; <i>also</i> Ore and its references].		
calcination of	67	91
character desirable	72	95
charges, composition of	73	96
making up	71, 74	95, 100
fluxes	25	27
fuels	26	29
grading ores	60	91

	ART.	PAGE
Ore-reduction, operations preliminary	65	91
roasting	23, 69	62, 91
methods of	68	92
in heaps	69	93
in kilns	70	94
smelting	24	27
Orthogonal strains in iron and steel	300	608
Overstrain of iron	299	604
evidence of	299	604
Paints	193	333
Phosphorus steel	168, 182	272, 370
Piling and reworking iron	234	416
Plate iron, Russian sheet	149	209
specifications for	315	653
tinned	146	206
manufacture of	147	208
weights of	148	208
Pneumatic process [<i>See Bessemer</i>].	133	188
Power required for rolls	194	332
Preservation of iron and steel	196	335
composition for	196	335
paints for	195	333
Puddling	34	44
balling the sponge	119	172
machines	118	172
methods of	117	165
process of	114	158
theory of	116	162
Punching iron and steel	275	523
Pyrites, iron	49	73
Rail and beam mill	126	183
Railway material	314	652
Red hematite	45	64
Refineries [<i>See Puddling</i>]	113	157
Resilience of iron	207	356
steels	236	422
Resistance of iron and steel [<i>See Strength</i>].		
Rest, relief of internal strain by	294	588
and effect of time under stress	295	590
Reworking iron	234	416
Reversing mill	130	185
Riehl's testing machine	215	368
Riveted work	273	518
Roasting ores	23, 67	26, 91
methods of	68	92
in heaps	69	93
in kilns	70	94
Rolled iron [<i>See Iron, Wrought</i>].	136	192
cold rolled	302	615
shapes	137	193
designing	144	204
peculiar	143	203
sheet, Russian	149	209
tin plate	146	206
manufacture of	147	208
weights of	148	208

	ART.	PAGE
Rolling	123	179
effect on strength of iron	142	201
power required for	133	188
mills, beam	126	183
continuous	127	183
distribution of men at	131	186
Hewitt's	132	186
power required for	133	188
rail	126	183
reversing	130	185
three-high	129	184
universal	128	183
mill work	120	173
Rolls	124	178
cooling, rate of	134	189
efficiency of	135	190
Roll trains	125	182
Safety, factors of	199	340
Sandberg's experiments on effect of cold on rails	286	556
Set [<i>See</i> Elastic Limit]	297	594
effect of orthogonal strains on	300	608
evidence of overstrain given by	299	604
Shafts [<i>See</i> Strength, Torsional]	277	526
Shearing	272	517
nuts	274	521
punching and	275	523
riveted work	273	518
Sheet iron, Russian	149	209
tin-plate	146	206
manufacture of	147	208
weights of	148	208
Shock [<i>See</i> Strength, Resilience]	296	592
effect of	206	355
impact and	219	375
proportioning to resist	208	359
"Short" irons	306	632
Siemens' process	109	155
steels	158, 179	235, 300
resilience	236	422
Siemens-Martin steel compared with Bessemer	239	427
Slag	89	122
Smelting	24	27
Spathic ores	47	70
Specifications	304	628
American	320	660
boiler-work	305	631
bridge-work	307, 308	633, 642
British	318	659
admiralty	319	659
Lloyds	319	659
constructions in iron and steel	309	645
Cooper lines	321	661
floors	317	658
girders	317	658
inspector's duties	322	662
iron construction	316	655
miscellaneous	311	648

	ART.	PAGE
Specifications, plate	315	653
railway material	314	652
steel	312	651
tests	310	647
welded materials	314	652
Specific heats	82	113
Squeezing	122	177
Statistics of iron manufacture	40	59
Stayed surfaces	246	445
Steam boilers	99	139
protection of	197	337
hoists	97	139
Steel [<i>See Iron, Metallurgy, Strength</i>].		
Bessemer and Siemens-Martin, compared	239	427
apparatus	160	241
chemistry of process	180	303
dephosphorization of	164	259
plant	161	246
process of manufacture of	162	254
properties of	163	258
qualities of	165	261
reactions in converter	181	304
boiler-plate, preservation of	197	337
tenacity of	238	426
bridge, tenacity of	237	423
cast	155	226
castings of	242	431
cementation of	177	296
chemical tests of	184	313
chrome	167, 182	266, 307
composition of Siemens'	179	300
compression, hardening by	191	328
corrosion of	192	328
crucible	156	227
compositions	278	297
definition of	150	210
durability of	193	331
fluxing of	159	239
hardening by compression	191	328
tempering	189	323
theory of	190	327
ingot	235	417
inspection test-pieces	283	544
Manufacture. [<i>See Table of Contents, Chap. VII, Arts.</i> 150-168; pp. 210-270].		
<i>See Bessemer, above.</i>		
carburization of iron	153	221
cementation	154	223
direct process	152	219
Siemens'	158	235
open-hearth	157	231
Siemens'	179	300
Siemens-Martin	239	427
nickel	241	431
open-hearth	157	231
phosphorus	168, 182	270, 307
physical properties of	187	317
tests of	184	313
piling and reworking	234	416

INDEX.

725

	ART.	PAGE
Steel, pneumatic [<i>See Bessemer</i>].		
preservation of.....	194	332
paints for.....	195	333
special compositions for.....	196	335
of steam boilers.....	197	337
resilience of.....	236	422
Siemens'.....	179	300
direct method.....	158	233
Siemens-Martin.....	239	427
<i>See Specifications.</i>		
<i>See Strain diagrams.</i>		
structures.....	309	645
tempering.....	189	323
theory of.....	190	327
tenacity of boiler plate.....	238	426
bridge steels.....	237	423
castings.....	242	430
ingot.....	235	417
special steels.....	241	430
wire.....	240	428
tests, chemical.....	184	313
inspection of test-piece.....	283	544
mild steel.....	243	433
physical.....	184	313
<i>See Strain diagrams.</i>		
tool steel.....	243	433
tool.....	282	542
tungsten.....	167, 182	266, 307
Whitworth.....	302	618
wire [<i>See Wire</i>].....	240	428
working.....	188	318
Stock houses at blast furnaces.....	100	140
Stoves, hot-blast.....	91	125
Whitwell's.....	92	129
Strain diagrams [<i>See Elastic Limit, Strength</i>].....	205	319
autographic testing machine, Thurston's.....	221	379
curves of resistance.....	202	346
iron, cast.....	245	444
in compression.....	251	460
wrought.....	279	533
metals, various.....	278	531
steel, mild.....	281	593
tool.....	282	542
Strength, autographic machine for testing, Thurston's.....	221	379
beams [<i>See transverse, below</i>].		
bars, long.....	233, 252	415, 461
Bessemer steel.....	160, 163	241, 258
".....	165, 239	261, 467
boiler flues.....	254	463
plate.....	238	426
riveted work.....	273	518
shells.....	247	448
stayed surfaces.....	246	445
bridge steels.....	237	423
chrome iron.....	231	409
cold-rolled iron.....	302	615
columns.....	255	465
flexure.....	256	466
formulas.....	258	468

	ART.	PAGE
Strength, columns, long.	252, 257	461, 466
composition, effect of.	210	361
compressive	249	456
bars, long.	252	461
cold-rolling.	302	615
columns [<i>See above</i>].		
cast-iron	251	460
cylinders.	254	463
flow of metal and.	293	585
flues	254	463
formulas for.	258	468
hardening by compression.	191	328
resistance.	249	456
effect of structure, etc.	250	457
strain diagrams	251	460
struts.	255	465
wrought-iron.	253	462
crystallization, effect of.	292	578
curves of resistance.	202	346
deductions in general.	230	408
effect of age on.	291	576
elastic limit, conclusions relative to	301	610
Emery's machine for testing.	218	372
normal variation of	298	600
orthogonal strains.	300	604
overstrains.	299	604
series of.	204	347
set.	297	594
equation of curves of resistance.	202	346
excessive, evidence of.	299	604
exposure, effect of	291	576
factors of safety.	199	340
Fairbanks' transverse testing-machine.	220	376
flexure [<i>See transverse, below</i>].		
flow of metals and effect on	293	585
flues	254	463
forms of resistance.	198	339
Gill's machine for testing.	216	370
heat, effect of	285	550
change of temperature	288	566
stress produced by.	289	568
Sandberg's, Styffe's and others' experiments.	286, 287	556, 559
sudden.	290	568
impact, machine for measuring.	219	375
inertia, geometrical moment of.	259	457
practical application.	260	477
ingot iron and steel	235	417
internal stress and strains.	212	365
Iron [<i>See all items under Iron, Steel, and Strength</i>].		
cast.	245	444
compressive.	251	460
cylinders	248	450
ingot.	235	417
ordnance	173	285
<i>See strain diagrams</i>	245	444
<i>See tenacity</i>	244	439
ingot iron	235	417
chain.	231	409
chrome	231	409

	ART.	PAGE
Strength, Iron, cold-rolled	302	615
ingot	235	417
values for	209	360
wrought, bars, long	233, 252	415, 461
boiler flues	254	403
plate	338	426
riveted work	273	518
shells	247	448
stayed surfaces	246	445
British standard	319	659
chrome iron	231	409
cold-rolled	312	615
commercial irons	228	404
compressive	253	462
bars, long	252	461
flow of metal	213	585
<i>See</i> Elastic Limit.		
flow of metal	293	585
flues	254	403
impact	219	375
internal stress and strain	252	365
relief by rest	294	588
nuts	274	521
orthogonal strains	300	608
overstrain, evidence of	299	604
piling and reworking	234	416
plate	238	426
proportioning to resist shock	208	359
punching	275	523
relative strength of metals	8	7
relief of internal stress by rest	294	588
resilience	207	356
rest, relief of internal stress by	294	588
reworking	234	416
riveted work	273	518
rolled iron	142	201
cold-rolled	312	615
plate	238	426
rupture, effect of velocity	296	592
shearing	272	517
nuts	274	521
punching	275	523
riveted work	273	518
shells, boiler	247	448
shock, effect of	206, 296	355, 592
proportioning to resist	208	359
size, effect of	229	407
standard	311	647
British	319	659
various	311	648
stayed surfaces	246	445
<i>See</i> Strain diagrams	279	533
strain, excessive, evidence of	299	604
orthogonal	300	608
strain and stress, internal	252	365
relief by rest	294	588
time under	295	590
varying load	303	618
tenacity boiler plate	238	426

	ART.	PAGE
Strength, Iron, Wrought, tenacity, comparisons of irons.....	228	404
relative of irons	8	7
size, effect of.....	229	407
wire	232	413
tests, standard.....	311	647
British.....	319	659
time ; flow of metal.....	293	585
transverse [<i>See</i> beams, <i>above</i>].		
<i>See</i> shock, <i>above</i> .		
<i>See</i> strain diagrams, <i>above</i> .		
time under stress.....	295	590
torsional.....	279	533
varying load ; (Wöhler's law).....	303	618
velocity of rupture	296	592
wire.....	232	413
Wöhler's law for varying loads.....	303	618
measures of resistance.....	200	343
methods of resistance.....	201	345
modifications by age.....	291	576
cold-rolling	302	615
crystallization	292	578
<i>See</i> Elastic Limit.		
exposure.....	291	576
flow of metal.....	293	585
<i>See</i> Heat.		
internal stress and strain.....	212	365
relief by rest.....	294	588
orthogonal strains.....	300	608
shock.....	206	355
<i>See</i> Strain diagrams.		
structure.....	250	457
time under stress.....	295	590
various	211	364
varying load.....	303	618
velocity of rupture	296	592
moment of inertia, geometrical.....	259	475
nuts.....	274	521
orthogonal strains	300	608
overstrain, evidence of	299	604
Olsen's machine for testing	217	371
piling and reworking metals.....	234	416
plate for boilers.....	238	426
proportioning for beams of uniform strength.....	267	495
to resist shock.....	208	359
punching, resistance to.....	274	523
relief of internal stress by rest.....	294	588
resilience.....	207	356
reworking metal.....	234	416
riveted work	273	518
rolled metal.....	142	201
cold	302	618
plate.....	238	426
rupture, effect of velocity.....	296	592
Sandberg's experiments of effect of heat.....	286, 287	556, 559
series of elastic limits.....	204	347
shafts.....	277	226
shells of boilers	247	448
shock, effect of.....	206, 296	355, 592
proportioning to resist	208	359

	ART.	PAGE
Strength, stayed surfaces	246	645
metals, various.	278	531
shearing.	272	517
nuts.	274	521
riveted work.	273	518
steel, mild.	281	539
tool.	282	543
strain, internal.	212	365
orthogonal.	300	618
relief by rest.	294	588
stress, effect of change of temperature.	288	566
time.	295	599
structure, of metals, effect of.	250	457
structures of iron and steel.	309	645
struts.	255	465
Styffe's experiments on effects of heat.	286, 287	566, 559
steel [<i>See Steel</i>].		
boiler plate.	238	426
bridge.	237	423
castings.	242	431
mild.	281	539
resilience.	236	422
special.	241	430
<i>See Strain Diagrams.</i>		
tool.	243, 282	433, 542
values for.	209	360
wire.	240	428
temperature [<i>See Heat</i>].		
tensile.	227	400
boiler-plate.	238	426
bridge steels.	237	423
cast iron.	244	439
fractures, surfaces.	284	547
iron.	227	400
commercial.	228	404
ingot.	235	417
metals, relative.	8	7
size, effect of.	229	407
steel, castings.	241	430
ingot.	235	417
special.	241	430
wire.	232	413
steel.	240	428
<i>See Testing Machines.</i>		
testing, methods of.	223	390
tests, records of [<i>See Arts. 224-226, pp. 391-400</i>].		
standard.	311	647
British.	319	659
various.	311	648
tool steels.	243	433
strain diagrams.	282	542
torsional, cast iron.	245	444
metals, various.	278	531
steel.	283	544
mild.	281	539
tool.	282	542
wrought iron.	279	533
Thurston's autographic testing machine.	221	379
transverse.	261	482

	ART.	PAGE
Strength, transverse beams ; constants.....	270	505
elastic resistance.....	268	496
experiments.....	269	502
formulas.....	264	488
resistances to flexure.....	262	485
rupture, theory.....	263	486
sections.....	266	493
of uniform strength.....	267	495
specifications.....	317	658
varying load, effect of.....	303	618
Wöhler's law.....	303	618
Telluric iron.....	43	61
Temperature [<i>See</i> Heat].		
Tempering [<i>See</i> Arts. 189-191, pp. 323-328].		
Tenacity [<i>See</i> Strength, Tensile].		
Testing-machines, Emery's, Fairbanks & Co's.....	218	372
Fairbanks' transverse.....	220	376
Gill's.....	216	370
impact.....	219	375
Olsen's.....	217	371
Riehle's.....	215	368
Thurston's autographic.....	221	379
Test piece, forms of.....	222	324
fractured surfaces.....	284	547
inspection of steel.....	283	544
wrought iron.....	280	537
Tests, standard.....	311	647
British.....	319	659
various.....	311	648
Tin plate.....	146	206
manufacture.....	147	208
weights.....	148	208
Titaniferous iron ores.....	51	76
Torsion [<i>See</i> Strength, torsional].		
Transverse [<i>See</i> Strength, transverse].		
Tungsten steel.....	167, 182	266, 307
Universal rolling mills.....	128	183
Water supply for blast furnaces.....	98	139
Weathering ores.....	64	89
Welded metal.....	313	651
Welding.....	183	309
Whitwell's hot blast stove.....	91	125
Whitworth steel.....	302	618
Wire drawing.....	178	196
effect on strength.....	142	201
gauges.....	141	201
resistance.....	140	199
tenacity.....	232	413
steel.....	240	428
Wöhler's law of effect of varying loads.....	303	618
Wolfram.....	52	78
Wrought iron [<i>See</i> Iron, wrought].		

SHORT-TITLE CATALOGUE

OF THE
PUBLICATIONS

OF
JOHN WILEY & SONS,

NEW YORK.

LONDON: CHAPMAN & HALL, LIMITED.

ARRANGED UNDER SUBJECTS.

Descriptive circulars sent on application.
Books marked with an asterisk are sold at *net prices only*.
All books are bound in cloth unless otherwise stated.

AGRICULTURE.

Armsby's Manual of Cattle-feeding.....	12mo,	\$1 75
“ Principles of Animal Nutrition.....	8vo,	4 00
Budd and Hansen's American Horticultural Manual: Part I.—Propagation, Culture, and Improvement....	12mo,	1 50
Part II.—Systematic Pomology. (<i>In preparation.</i>)		
Downing's Fruits and Fruit-trees of America.....	8vo,	5 00
Elliott's Engineering for Land Drainage.....	12mo,	1 50
Grottenfelt's Principles of Modern Dairy Practice. (Woll.)..	12mo,	2 00
Kemp's Landscape Gardening.....	12mo,	2 50
Maynard's Landscape Gardening as Applied to Home Decoration.	12mo,	1 50
Sanderson's Insects Injurious to Staple Crops.....	12mo,	1 50
“ Insects Injurious to Garden Crops. (<i>In preparation.</i>)		
“ Insects Injuring Fruits. (<i>In preparation.</i>)		
Stockbridge's Rocks and Soils.....	8vo,	2 50
Woll's Handbook for Farmers and Dairymen.....	16mo,	1 50

ARCHITECTURE.

Baldwin's Steam Heating for Buildings.....	12mo,	2 50
Berg's Buildings and Structures of American Railroads....	4to,	5 00
Birkmire's Planning and Construction of American Theatres.	8vo,	3 00
“ Architectural Iron and Steel.....	8vo,	3 50
“ Compound Riveted Girders as Applied in Buildings.	8vo,	2 00
“ Planning and Construction of High Office Buildings.	8vo,	3 50
“ Skeleton Construction in Buildings.....	8vo,	3 00
Briggs's Modern American School Buildings.....	8vo,	4 00
Carpenter's Heating and Ventilating of Buildings.....	8vo,	4 00
Freitag's Architectural Engineering. 2d Edition, Rewritten.	8vo,	3 50
“ Fireproofing of Steel Buildings.....	8vo,	2 50
French and Ives's Stereotomy.....	8vo,	2 50
Gerhard's Guide to Sanitary House-inspection.....	16mo,	1 00
“ Theatre Fires and Panics.....	12mo,	1 50
Hatfield's American House Carpenter.....	8vo,	5 00
Holly's Carpenters' and Joiners' Handbook.....	18mo,	75
Johnson's Statics by Algebraic and Graphic Methods.....	8vo,	2 00

Kidder's Architect's and Builder's Pocket-book..16mo, morocco,	4 00
Merrill's Stones for Building and Decoration.....8vo,	5 00
Monckton's Stair-building.....4to,	4 00
Patton's Practical Treatise on Foundations.....8vo,	5 00
Siebert and Biggin's Modern Stone-cutting and Masonry..8vo,	1 50
Snow's Principal Species of Wood. (<i>In preparation.</i>)	
Wait's Engineering and Architectural Jurisprudence.....8vo,	6 00
Sheep,	6 50
" Law of Operations Preliminary to Construction in En-	
gineering and Architecture.....8vo,	5 00
Sheep,	5 50
" Law of Contracts.....8vo,	3 00
Woodbury's Fire Protection of Mills.....8vo,	2 50
Worcester and Atkinson's Small Hospitals, Establishment and	
Maintenance, and Suggestions for Hospital Architecture,	
with Plans for a Small Hospital.....12mo,	1 25
The World's Columbian Exposition of 1893.....Large 4to,	1 00

ARMY AND NAVY.

Bernadou's Smokeless Powder, Nitro-cellulose, and the Theory	
of the Cellulose Molecule.....12mo,	2 50
* Bruff's Text-book Ordnance and Gunnery.....8vo,	6 00
Chase's Screw Propellers and Marine Propulsion.....8vo,	3 00
Craig's Azimuth.....4to,	3 50
Crehore and Squire's Polarizing Photo-chronograph.....8vo,	3 00
Cronkrite's Gunnery for Non-commissioned Officers..24mo, mor.,	2 00
* Davis's Elements of Law.....8vo,	2 50
" Treatise on the Military Law of United States..8vo,	7 00
Sheep,	7 50
De Brack's Cavalry Outpost Duties. (Carr.)....24mo, morocco,	2 00
Dietz's Soldier's First Aid Handbook.....16mo, morocco,	1 25
* Dredg's Modern French Artillery.....4to, half morocco,	15 00
Durand's Resistance and Populsion of Ships.....8vo,	5 00
* Dyer's Handbook of Light Artillery.....12mo,	3 00
Eisler's Modern High Explosives.....8vo,	4 00
* Fieberger's Text-book on Field Fortification.....Small 8vo,	2 00
Hamilton's The Gunner's Catechism.....18mo,	1 00
* Hoff's Elementary Naval Tactics.....8vo,	1 50
Ingalls's Handbook of Problems in Direct Fire.....8vo,	4 00
" Ballistic Tables.....8vo,	1 50
Lyons's Treatise on Electromagnetic Phenomena.....8vo,	6 00
* Mahan's Permanent Fortifications. (Mercur.)..8vo, half mor.,	7 50
Manual for Courts-martial.....16mo, morocco,	1 50
* Mercur's Attack of Fortified Places.....12mo,	2 00
" Elements of the Art of War.....8vo,	4 00
Metcalf's Cost of Manufactures—And the Administration of	
Workshops, Public and Private.....8vo,	5 00
" Ordnance and Gunnery.....12mo,	5 00
Murray's Infantry Drill Regulations.....18mo, paper,	10
* Phelps's Practical Marine Surveying.....8vo,	2 50
Powell's Army Officer's Examiner.....12mo,	4 00
Sharpe's Art of Subsisting Armies in War.....18mo, morocco,	1 50
* Walke's Lectures on Explosives.....8vo,	4 00
* Wheeler's Siege Operations and Military Mining.....8vo,	2 00
Winthrop's Abridgment of Military Law.....12mo,	2 50
Woodhull's Notes on Military Hygiene.....16mo,	1 50
Young's Simple Elements of Navigation.....16mo, morocco,	1 00
Second Edition, Enlarged and Revised.....16mo, mor.,	2 00

ASSAYING.

Fletcher's Practical Instructions in Quantitative Assaying with the Blowpipe.....	12mo, morocco, 1 50
Furman's Manual of Practical Assaying.....	8vo, 3 00
Miller's Manual of Assaying.....	12mo, 1 00
O'Driscoll's Notes on the Treatment of Gold Ores.....	8vo, 2 00
Ricketts and Miller's Notes on Assaying.....	8vo, 3 00
Wilson's Cyanide Processes.....	12mo, 1 50
" Chlorination Process.....	12mo, 1 50

ASTRONOMY.

Comstock's Field Astronomy for Engineers.....	8vo, 2 50
Craig's Azimuth.....	4to, 3 50
Doolittle's Treatise on Practical Astronomy.....	8vo, 4 00
Gore's Elements of Geodesy.....	8vo, 2 50
Hayford's Text-book of Geodetic Astronomy.....	8vo, 3 00
Merriman's Elements of Precise Surveying and Geodesy....	8vo, 2 50
* Michie and Harlow's Practical Astronomy.....	8vo, 3 00
* White's Elements of Theoretical and Descriptive Astronomy.	12mo, 2 00

BOTANY.

Baldwin's Orchids of New England.....	Small 8vo, 1 50
Davenport's Statistical Methods, with Special Reference to Biological Variation.....	16mo, morocco, 1 25
Thomé and Bennett's Structural and Physiological Botany.	16mo, 2 25
Westermaier's Compendium of General Botany. (Schneider.)	8vo, 2 00

CHEMISTRY.

Adriance's Laboratory Calculations and Specific Gravity Tables.	12mo, 1 25
Allen's Tables for Iron Analysis.....	8vo, 3 00
Arnold's Compendium of Chemistry. (Mandel.) (<i>In preparation.</i>)	
Austen's Notes for Chemical Students.....	12mo, 1 50
Bernadou's Smokeless Powder.—Nitro-cellulose, and Theory of the Cellulose Molecule.....	12mo, 2 50
Bolton's Quantitative Analysis.....	8vo, 1 50
Brush and Penfield's Manual of Determinative Mineralogy....	8vo, 4 00
Classen's Quantitative Chemical Analysis by Electrolysis. (Her- rick—Boltwood.)	8vo, 3 00
Cohn's Indicators and Test-papers.....	12mo, 2 00
Craft's Short Course in Qualitative Chemical Analysis. (Schaefer.)	12mo, 2 00
Drechsel's Chemical Reactions. (Merrill.).....	12mo, 1 25
Eissler's Modern High Explosives.....	8vo, 4 00
Effront's Enzymes and their Applications. (Prescott.)....	8vo, 3 00
Erdmann's Introduction to Chemical Preparations. (Dunlap.)	12mo, 1 25
Fletcher's Practical Instructions in Quantitative Assaying with the Blowpipe.....	12mo, morocco, 1 50
Fowler's Sewage Works Analyses.....	12mo, 2 00
Fresenius's Manual of Qualitative Chemical Analysis. (Wells.)	8vo, 5 00
" Manual of Qualitative Chemical Analysis. Part I. Descriptive. (Wells.).....	8vo, 3 00
" System of Instruction in Quantitative Chemical Analysis. (Allen.).....	8vo, 6 00

Fuertes's Water and Public Health.....	12mo,	1 50
Furman's Manual of Practical Assaying.....	8vo,	3 00
Gill's Gas and Fuel Analysis for Engineers.....	12mo,	1 25
Grotenfelt's Principles of Modern Dairy Practice. (Woll.)	12mo,	2 00
Hammarsten's Text-book of Physiological Chemistry. (Mandel.)	8vo,	4 00
Helm's Principles of Mathematical Chemistry. (Morgan.)	12mo,	1 50
Hinds's Inorganic Chemistry.....	8vo,	3 00
* " Laboratory Manual for Students.....	12mo,	75
Holleman's Text-book of Inorganic Chemistry. (Cooper.)	8vo,	2 50
" " " " Organic " (Walker and Mott.)	(In preparation.)	
Hopkins's Oil-chemists' Handbook.....	8vo,	3 00
Keep's Cast Iron.....	8vo,	2 50
Ladd's Manual of Quantitative Chemical Analysis.....	12mo,	1 00
Landauer's Spectrum Analysis. (Tingle.).....	8vo,	3 00
Lassar-Cohn's Practical Urinary Analysis. (Lorenz.)	(In preparation.)	
Leach's The Inspection and Analysis of Food with Special Reference to State Control. (In preparation.)		
Löb's Electrolysis and Electrosynthesis of Organic Compounds. (Lorenz.)	12mo,	1 00
Mandel's Handbook for Bio-chemical Laboratory.....	12mo,	1 50
Mason's Water-supply. (Considered Principally from a Sanitary Standpoint.) 3d Edition, Rewritten.....	8vo,	4 00
" Examination of water. (Chemical and Bacteriological.)	12mo,	1 25
Meyer's Determination of Radicles in Carbon Compounds. (Tingle.)	12mo,	1 00
Miller's Manual of Assaying.....	12mo,	1 00
Mixer's Elementary Text-book of Chemistry.....	12mo,	1 50
Morgan's Outline of Theory of Solution and its Results.	12mo,	1 00
" Elements of Physical Chemistry.....	12mo,	2 00
Nichols's Water-supply. (Considered mainly from a Chemical and Sanitary Standpoint, 1883.)	8vo,	2 50
O'Brine's Laboratory Guide in Chemical Analysis.....	8vo,	2 00
O'Driscoll's Notes on the Treatment of Gold Ores.....	8vo,	2 00
Ost and Kolbeck's Text-book of Chemical Technology. (Lorenz—Bozart.)	(In preparation.)	
* Penfield's Notes on Determinative Mineralogy and Record of Mineral Tests.....	8vo, paper,	0 50
Pinner's Introduction to Organic Chemistry. (Austen.)	12mo,	1 50
Poole's Calorific Power of Fuels.....	8vo,	3 00
* Reising's Guide to Piece-dyeing.....	8vo,	25 00
Richards and Woodman's Air, Water, and Food from a Sanitary Standpoint	8vo,	2 00
Richards's Cost of Living as Modified by Sanitary Science	12mo,	1 00
" Cost of Food, a Study in Dietsaries.....	12mo,	1 00
* Richards and Williams's The Dietary Computer.....	8vo,	1 50
Ricketts and Russell's Skeleton Notes upon Inorganic Chemistry. (Part I.—Non-metallic Elements.)	8vo, morocco,	75
Ricketts and Miller's Notes on Assaying.....	8vo,	3 00
Rideal's Sewage and the Bacterial Purification of Sewage.	8vo,	3 50
Ruddiman's Incompatibilities in Prescriptions.....	8vo,	2 00
Schimpf's Text-book of Volumetric Analysis.....	12mo,	2 50
Spencer's Handbook for Chemists of Beet-sugar Houses.	16mo,	3 00
" Handbook for Sugar Manufacturers and their Chemists	16mo, morocco,	2 00
Stockbridge's Rocks and Soils.....	8vo,	2 50

* Tillman's Elementary Lessons in Heat.....	8vo,	1 50
* " Descriptive General Chemistry.....	8vo,	3 00
Turneaure and Russell's Public Water-supplies.....	8vo,	5 00
Van Deventer's Physical Chemistry for Beginners. (Boltwood.)	12mo,	1 50
* Walke's Lectures on Explosives.....	8vo,	4 00
Wells's Laboratory Guide in Qualitative Chemical Analysis.....	8vo,	1 50
" Short Course in Inorganic Qualitative Chemical Analysis for Engineering Students.....	12mo,	1 50
Whipple's Microscopy of Drinking-water.....	8vo,	3 50
Wiechmann's Sugar Analysis.....	Small 8vo,	2 50
Wilson's Cyanide Processes.....	12mo,	1 50
" Chlorination Process.....	12mo,	1 50
Wulling's Elementary Course in Inorganic Pharmaceutical and Medical Chemistry.....	12mo,	2 00

CIVIL ENGINEERING.

BRIDGES AND ROOFS. HYDRAULICS. MATERIALS OF ENGINEERING. RAILWAY ENGINEERING.

Baker's Engineers' Surveying Instruments.....	12mo,	3 00
Bixby's Graphical Computing Table...Paper, 19½ x 24½ inches.		25
** Burr's Ancient and Modern Engineering and the Isthmian Canal..... (Postage, 27 cents additional)	8vo, net,	3 50
Comstock's Field Astronomy for Engineers.....	8vo,	2 50
Davis's Elevation and Stadia Tables.....	8vo,	1 00
Elliott's Engineering for Land Drainage.....	12mo,	1 50
Folwell's Sewerage. (Designing and Maintenance.).....	8vo,	3 00
Freitag's Architectural Engineering. 2d Ed., Rewritten.....	8vo,	3 50
French and Ives's Stereotomy.....	8vo,	2 50
Goodhue's Municipal Improvements.....	12mo,	1 75
Goodrich's Economic Disposal of Towns' Refuse.....	8vo,	3 50
Gore's Elements of Geodesy.....	8vo,	2 50
Hayford's Text-book of Geodetic Astronomy.....	8vo,	3 00
Howe's Retaining-walls for Earth.....	12mo,	1 25
Johnson's Theory and Practice of Surveying.....	Small 8vo,	4 00
" Statics by Algebraic and Graphic Methods.....	8vo,	2 00
Kierstedt's Sewage Disposal.....	12mo,	1 25
Laplace's Philosophical Essay on Probabilities. (Truscott and Emory.).....	12mo,	2 00
Mahan's Treatise on Civil Engineering. (1873.) (Wood.)	8vo,	5 00
* Mahan's Descriptive Geometry.....	8vo,	1 50
Merriman's Elements of Precise Surveying and Geodesy...	8vo,	2 50
Merriman and Brooks's Handbook for Surveyors...	16mo, mor.,	2 00
Merriman's Elements of Sanitary Engineering.....	8vo,	2 00
Nugent's Plane Surveying.....	8vo,	3 50
Ogden's Sewer Design.....	12mo,	2 00
Patton's Treatise on Civil Engineering.....	8vo, half leather,	7 50
Reed's Topographical Drawing and Sketching.....	4to,	5 00
Rideal's Sewage and the Bacterial Purification of Sewage...	8vo,	3 50
Siebert and Biggin's Modern Stone-cutting and Masonry...	8vo,	1 50
Smith's Manual of Topographical Drawing. (McMillan.)	8vo,	2 50
* Trautwine's Civil Engineer's Pocket-book...	16mo, morocco,	5 00
Wait's Engineering and Architectural Jurisprudence.....	8vo,	6 00
" Law of Operations Preliminary to Construction in Engineering and Architecture.....	8vo,	5 00
	Sheep,	5 50
Wait's Law of Contracts.....	8vo,	3 00
Warren's Stereotomy—Problems in Stone-cutting.....	8vo,	2 50

Webb's Problems in the Use and Adjustment of Engineering Instruments	16mo, morocco,	1 25
* Wheeler's Elementary Course of Civil Engineering.....	8vo,	4 00
Wilson's Topographic Surveying.....	8vo,	3 50

BRIDGES AND ROOFS.

Boller's Practical Treatise on the Construction of Iron Highway Bridges	8vo,	2 00
* Boller's Thames River Bridge.....	4to, paper,	5 00
Burr's Course on the Stresses in Bridges and Roof Trusses, Arched Ribs, and Suspension Bridges.....	8vo,	3 50
Du Bois's Mechanics of Engineering. Vol. II.....	Small 4to,	10 00,
Foster's Treatise on Wooden Trestle Bridges.....	4to,	5 00
Fowler's Cofferdam Process for Piers.....	8vo,	2 50
Greene's Roof Trusses.....	8vo,	1 25
" Bridge Trusses.....	8vo,	2 50
" Arches in Wood, Iron, and Stone.....	8vo,	2 50
Howe's Treatise on Arches.....	8vo,	4 00
" Design of Simple Roof-trusses in Wood and Steel.	8vo,	2 00
Johnson, Bryan and Turneure's Theory and Practice in the Designing of Modern Framed Structures.....	Small 4to,	10 00
Merriman and Jacoby's Text-book on Roofs and Bridges:		
Part I.—Stresses in Simple Trusses.....	8vo,	2 50
Part II.—Graphic Statics.....	8vo,	2 50
Part III.—Bridge Design. Fourth Ed., Rewritten.....	8vo,	2 50
Part IV.—Higher Structures.....	8vo,	2 50
Morison's Memphis Bridge.....	4to,	10 00
Waddell's De Pontibus, a Pocket Book for Bridge Engineers.		
16mo, mor.,		3 00
" Specifications for Steel Bridges.....	12mo,	1 25
Wood's Treatise on the Theory of the Construction of Bridges and Roofs	8vo,	2 00
Wright's Designing of Draw-spans:		
Part I.—Plate-girder Draws.....	8vo,	2 50
Part II.—Riveted-truss and Pin-connected Long-span Draws.		
8vo,		2 50
Two parts in one volume.....	8vo,	3 50

HYDRAULICS.

Bazin's Experiments upon the Contraction of the Liquid Vein Issuing from an Orifice. (Trautwine.).....	8vo,	2 00
Bovey's Treatise on Hydraulics.....	8vo,	5 00
Church's Mechanics of Engineering.....	8vo,	6 00
" Diagrams of Mean Velocity of Water in Open Channels		
paper,		1 50
Coffin's Graphical Solution of Hydraulic Problems. 16mo, mor.,		2 50
Fletcher's Dynamometers, and the Measurement of Power. 12mo,		3 00
Folwell's Water-supply Engineering.....	8vo,	4 00
Frizell's Water-power.....	8vo,	5 00
Fuertes's Water and Public Health.....	12mo,	1 50
" Water-filtration Works.....	12mo,	2 50
Ganguillet and Kutter's General Formula for the Uniform Flow of Water in Rivers and Other Channels. (Hering and Trautwine.).....	8vo,	4 00
Hazen's Filtration of Public Water-supply.....	8vo,	3 00
Hazlehurst's Towers and Tanks for Water-works.....	8vo,	2 50
Herschel's 115 Experiments on the Carrying Capacity of Large, Riveted, Metal Conduits.....	8vo,	2 00

Mason's Water-supply. (Considered Principally from a Sanitary Standpoint.)	8vo,	4 00
Merriman's Treatise on Hydraulics	8vo,	4 00
* Michie's Elements of Analytical Mechanics	8vo,	4 00
Schuyler's Reservoirs for Irrigation, Water-power, and Domestic Water-supply	Large 8vo,	5 00
Turneaure and Russell. Public Water-supplies	8vo,	5 00
Wegmann's Design and Construction of Dams	4to,	5 00
" Water-supply of the City of New York from 1658 to 1895	4to,	10 00
Weishach's Hydraulics and Hydraulic Motors. (Du Bois.)	8vo,	5 00
Wilson's Manual of Irrigation Engineering	Small 8vo,	4 00
Wolff's Windmill as a Prime Mover	8vo,	3 00
Wood's Turbines	8vo,	2 50
" Elements of Analytical Mechanics	8vo,	3 00

MATERIALS OF ENGINEERING.

Baker's Treatise on Masonry Construction	8vo,	5 00
" Roads and Pavements	8vo,	5 00
Black's United States Public Works	Oblong 4to,	5 00
Bovey's Strength of Materials and Theory of Structures	8vo,	7 50
Burr's Elasticity and Resistance of the Materials of Engineering	8vo,	5 00
Byrne's Highway Construction	8vo,	5 00
" Inspection of the Materials and Workmanship Employed in Construction	16mo,	3 00
Church's Mechanics of Engineering	8vo,	6 00
Du Bois's Mechanics of Engineering. Vol. I	Small 4to,	7 50
Johnson's Materials of Construction	Large 8vo,	6 00
Keep's Cast Iron	8vo,	2 50
Lanza's Applied Mechanics	8vo,	7 50
Martens's Handbook on Testing Materials. (Henning.)	2 v., 8vo,	7 50
Merrill's Stones for Building and Decoration	8vo,	5 00
Merriman's Text-book on the Mechanics of Materials	8vo,	4 00
Merriman's Strength of Materials	12mo,	1 00
Metcalf's Steel. A Manual for Steel-users	12mo,	2 00
Patton's Practical Treatise on Foundations	8vo,	5 00
Rockwell's Roads and Pavements in France	12mo,	1 25
Smith's Wire: Its Use and Manufacture	Small 4to,	3 00
" Materials of Machines	12mo,	1 00
Snow's Principal Species of Wood. (<i>In preparation.</i>)		
Spalding's Hydraulic Cement	12mo,	2 00
" Text-book on Roads and Pavements	12mo,	2 00
Thurston's Materials of Engineering	3 Parts, 8vo,	8 00
Part I.—Non-metallic Materials of Engineering and Metallurgy	8vo,	2 00
Part II.—Iron and Steel	8vo,	3 50
Part III.—A Treatise on Brasses, Bronzes and Other Alloys and Their Constituents	8vo,	2 50
Thurston's Text-book of the Materials of Construction	8vo,	5 00
Tillson's Street Pavements and Paving Materials	8vo,	4 00
Waddell's De Pontibus. (A Pocket-book for Bridge Engineers.)	16mo, morocco,	3 00
" Specifications for Steel Bridges	12mo,	1 25
Wood's Treatise on the Resistance of Materials, and an Appendix on the Preservation of Timber	8vo,	2 00
" Elements of Analytical Mechanics	8vo,	3 00

Smith's Manual of Topographical Drawing. (McMillan.)	8vo,	2 50
Warren's Elements of Plane and Solid Free-hand Geometrical Drawing	12mo,	1 00
" Drafting Instruments and Operations	12mo,	1 25
" Manual of Elementary Projection Drawing	12mo,	1 50
" Manual of Elementary Problems in the Linear Perspective of Form and Shadow	12mo,	1 00
" Plane Problems in Elementary Geometry	12mo,	1 25
" Primary Geometry	12mo,	75
" Elements of Descriptive Geometry, Shadows, and Perspective	8vo,	3 50
" General Problems of Shades and Shadows	8vo,	3 00
" Elements of Machine Construction and Drawing	8vo,	7 50
" Problems, Theorems, and Examples in Descriptive Geometry	8vo,	2 50
Weisbach's Kinematics and the Power of Transmission. (Herrmann and Klein.)	8vo,	5 00
Whelpley's Practical Instruction in the Art of Letter Engraving	12mo,	2 00
Wilson's Topographic Surveying	8vo,	3 50
Wilson's Free-hand Perspective	8vo,	2 50
Woolf's Elementary Course in Descriptive Geometry	Large 8vo,	3 00

ELECTRICITY AND PHYSICS.

Anthony and Brackett's Text-book of Physics. (Magie.)	Small 8vo,	3 00
Anthony's Lecture-notes on the Theory of Electrical Measurements	12mo,	1 00
Benjamin's History of Electricity	8vo,	3 00
Benjamin's Voltaic Cell	8vo,	3 00
Classen's Quantitative Chemical Analysis by Electrolysis. (Herrick and Boltwood.)	8vo,	3 00
Crehore and Squier's Polarizing Photo-chronograph	8vo,	3 00
Dawson's Electric Railways and Tramways	Small 4to, half mor.,	12 50
Dawson's "Engineering" and Electric Traction Pocket-book.	16mo, morocco,	4 00
Flather's Dynamometers, and the Measurement of Power	12mo,	3 00
Gilbert's De Magnete. (Mottelay.)	8vo,	2 50
Holman's Precision of Measurements	8vo,	2 00
" Telescopic Mirror-scale Method, Adjustments, and Tests	Large 8vo,	75
Landauer's Spectrum Analysis. (Tingle.)	8vo,	3 00
Le Chatelier's High-temperature Measurements. (Boudouard—Burgess.)	12mo,	3 00
Löb's Electrolysis and Electrosynthesis of Organic Compounds. (Lorenz.)	12mo,	1 00
Lyons's Treatise on Electromagnetic Phenomena	8vo,	6 00
* Michie. Elements of Wave Motion Relating to Sound and Light	8vo,	4 00
Niaudet's Elementary Treatise on Electric Batteries (Fishback.)	12mo,	2 50
* Parshall and Hobart's Electric Generators	Small 4to, half mor.,	10 00
Ryan, Norris, and Hoxie's Electrical Machinery. (<i>In preparation.</i>)		
Thurston's Stationary Steam-engines	8vo,	2 50
* Tillman. Elementary Lessons in Heat	8vo,	1 50
Tory and Pitcher. Manual of Laboratory Physics	Small 8vo,	2 00

LAW.

• Davis. Elements of Law.....	8vo,	2 50
• “ Treatise on the Military Law of United States.....	8vo,	7 00
•	Sheep,	7 50
Manual for Courts-martial.....	16mo, morocco,	1 50
Wait’s Engineering and Architectural Jurisprudence.....	8vo,	6 00
	Sheep,	6 50
“ Law of Operations Preliminary to Construction in Engineering and Architecture.....	8vo,	5 00
	Sheep,	5 50
“ Law of Contracts.....	8vo,	3 00
Winthrop’s Abridgment of Military Law.....	12mo,	2 50

MANUFACTURES.

Beaumont’s Woollen and Worsted Cloth Manufacture....	12mo,	1 50
Bernadou’s Smokeless Powder—Nitro-cellulose and Theory of the Cellulose Molecule.....	12mo,	2 50
Bolland’s Iron Founder.....	12mo, cloth,	2 50
“ “The Iron Founder” Supplement.....	12mo,	2 50
“ Encyclopedia of Founding and Dictionary of Foundry Terms Used in the Practice of Moulding....	12mo,	3 00
Eissler’s Modern High Explosives.....	8vo,	4 00
Eiffont’s Enzymes and their Applications. (Prescott)...	8vo,	3 00
Fitzgerald’s Boston Machinist.....	18mo,	1 00
Ford’s Boiler Making for Boiler Makers.....	18mo,	1 00
Hopkins’s Oil-chemists’ Handbook.....	8vo,	3 00
Keep’s Cast Iron.....	8vo	2 50
Leach’s The Inspection and Analysis of Food with Special Reference to State Control. (<i>In preparation.</i>)		
Metcalf’s Steel. A Manual for Steel-users.....	12mo,	2 00
Metcalf’s Cost of Manufactures—And the Administration of Workshops, Public and Private.....	8vo,	5 00
Meyer’s Modern Locomotive Construction.....	4to,	10 00
• Reisig’s Guide to Piece-dyeing.....	8vo,	25 00
Smith’s Press-working of Metals.....	8vo,	3 00
“ Wire: Its Use and Manufacture.....	Small 4to,	3 00
Spalding’s Hydraulic Cement.....	12mo,	2 00
Spencer’s Handbook for Chemists of Beet-sugar Houses.	16mo, morocco,	3 00
“ Handbook for Sugar Manufacturers and their Chemists.....	16mo, morocco,	2 00
Thurston’s Manual of Steam-boilers, their Designs, Construction and Operation.....	8vo,	5 00
* Walks’s Lectures on Explosives.....	8vo,	4 00
West’s American Foundry Practice.....	12mo,	2 50
“ Moulder’s Text-book.....	12mo,	2 50
Wiechmann’s Sugar Analysis.....	Small 8vo,	2 50
Wolff’s Windmill as a Prime Mover.....	8vo,	3 00
Woodbury’s Fire Protection of Mills.....	8vo,	2 50

MATHEMATICS.

Baker’s Elliptic Functions.....	8vo,	1 50
• Baas’s Elements of Differential Calculus.....	12mo,	4 00
Briggs’s Elements of Plane Analytic Geometry.....	12mo,	1 00
Chapman’s Elementary Course in Theory of Equations...	12mo,	1 50
Compton’s Manual of Logarithmic Computations.....	12mo,	1 50

Davis's Introduction to the Logic of Algebra.....	8vo,	1 50
*Dickson's College Algebra.....	Large 12mo,	1 50
* " Introduction to the Theory of Algebraic Equations.	Large 12mo,	1 25
Halsted's Elements of Geometry.....	8vo,	1 75
" Elementary Synthetic Geometry.....	8vo,	1 50
* Johnson's Three-place Logarithmic Tables: Vest-pocket size,	pap.,	15
	100 copies for	5 00
* Mounted on heavy cardboard, 8 x 10 inches,		25
	10 copies for	2 00
" Elementary Treatise on the Integral Calculus.	Small 8vo,	1 50
" Curve Tracing in Cartesian Co-ordinates.....	12mo,	1 00
" Treatise on Ordinary and Partial Differential Equations.....	Small 8vo,	3 50
" Theory of Errors and the Method of Least Squares.....	12mo,	1 50
* " Theoretical Mechanics.....	12mo,	3 00
Laplace's Philosophical Essay on Probabilities. (Truscott and Embry.).....	12mo,	2 00
* Ludlow and Bass. Elements of Trigonometry and Logarithmic and Other Tables.....	8vo,	3 00
" Trigonometry. Tables published separately..	Each,	2 00
Merriman and Woodward. Higher Mathematics.....	8vo,	5 00
Merriman's Method of Least Squares.....	8vo,	2 00
Rice and Johnson's Elementary Treatise on the Differential Calculus.....	Small 8vo,	3 00
" Differential and Integral Calculus. 2 vols.	Small 8vo,	2 50
" in one.....	Small 8vo,	2 00
Wood's Elements of Co-ordinate Geometry.....	8vo,	2 00
" Trigonometry: Analytical, Plane, and Spherical....	12mo,	1 00

MECHANICAL ENGINEERING.

MATERIALS OF ENGINEERING, STEAM ENGINES AND BOILERS.

Baldwin's Steam Heating for Buildings.....	12mo,	2 50
Barr's Kinematics of Machinery.....	8vo,	2 50
* Bartlett's Mechanical Drawing.....	8vo,	3 00
Benjamin's Wrinkles and Recipes.....	12mo,	2 00
Carpenter's Experimental Engineering.....	8vo,	6 00
" Heating and Ventilating Buildings.....	8vo,	4 00
Clerk's Gas and Oil Engine.....	Small 8vo,	4 00
Coolidge's Manual of Drawing.....	8vo, paper,	1 00
Cromwell's Treatise on Toothed Gearing.....	12mo,	1 50
" Treatise on Belts and Pulleys.....	12mo,	1 50
Durley's Kinematics of Machines.....	8vo,	4 00
Flather's Dynamometers, and the Measurement of Power ..	12mo,	3 00
" Rope Driving.....	12mo,	2 00
Gill's Gas and Fuel Analysis for Engineers.....	12mo,	1 25
Hall's Car Lubrication.....	12mo,	1 00
Jones's Machine Design:		
Part I.—Kinematics of Machinery.....	8vo,	1 50
Part II.—Form, Strength and Proportions of Parts.....	8vo,	3 00
Kent's Mechanical Engineers' Pocket-book....	16mo, morocco,	5 00
Kerr's Power and Power Transmission.....	8vo,	2 00

MacCord's Kinematics; or, Practical Mechanism.....	8vo,	5 00
" Mechanical Drawing.....	4to,	4 00
" Velocity Diagrams.....	8vo,	1 50
Mahan's Industrial Drawing. (Thompson.).....	8vo,	3 50
Poole's Calorific Power of Fuels.....	8vo,	3 00
Reid's Course in Mechanical Drawing.....	8vo,	2 00
" Text-book of Mechanical Drawing and Elementary Machine Design.....	8vo,	3 00
Richards's Compressed Air.....	12mo,	1 50
Robinson's Principles of Mechanism.....	8vo,	3 00
Smith's Press-working of Metals.....	8vo,	3 00
Thurston's Treatise on Friction and Lost Work in Machin- ery and Mill Work.....	8vo,	3 00
" Animal as a Machine and Prime Motor and the Laws of Energetics.....	12mo,	1 00
Warren's Elements of Machine Construction and Drawing.....	8vo,	7 50
Weisbach's Kinematics and the Power of Transmission. (Herr- mann-Klein.).....	8vo,	5 00
" Machinery of Transmission and Governors. (Herr- mann-Klein.).....	8vo,	5 00
" Hydraulics and Hydraulic Motors. (Du Bois.).....	8vo,	5 00
Wolf's Windmill as a Prime Mover.....	8vo,	3 00
Wood's Turbines.....	8vo,	2 50

MATERIALS OF ENGINEERING.

Bovey's Strength of Materials and Theory of Structures.....	8vo,	7 50
Burr's Elasticity and Resistance of the Materials of Engineer- ing.....	8vo,	5 00
Church's Mechanics of Engineering.....	8vo,	6 00
Johnson's Materials of Construction.....	Large 8vo,	6 00
Keep's Cast Iron.....	8vo,	2 50
Lanza's Applied Mechanics.....	8vo,	7 50
Martens's Handbook on Testing Materials. (Henning.).....	8vo,	7 50
Merriman's Text-book on the Mechanics of Materials.....	8vo,	4 00
" Strength of Materials.....	12mo,	1 00
Metcalf's Steel. A Manual for Steel-users.....	12mo,	2 00
Smith's Wire: Its Use and Manufacture.....	Small 4to,	3 00
" Materials of Machines.....	12mo,	1 00
Thurston's Materials of Engineering.....	3 vols., 8vo,	8 00
Part II.—Iron and Steel.....	8vo,	3 50
Part III.—A Treatise on Brasses, Bronzes and Other Alloys and their Constituents.....	8vo,	2 50
Thurston's Text-book of the Materials of Construction.....	8vo,	5 00
Wood's Treatise on the Resistance of Materials and an Ap- pendix on the Preservation of Timber.....	8vo,	2 00
" Elements of Analytical Mechanics.....	8vo,	3 00

STEAM ENGINES AND BOILERS.

Carnot's Reflections on the Motive Power of Heat. (Thurston.) 12mo,	1 50
Dawson's "Engineering" and Electric Traction Pocket-book. 16mo, morocco,	4 00
Ford's Boiler Making for Boiler Makers.....	18mo, 1 00
Goss's Locomotive Sparks.....	8vo, 2 00
Hemenway's Indicator Practice and Steam-engine Economy. 12mo,	2 00
Hutton's Mechanical Engineering of Power Plants.....	8vo, 5 00
" Heat and Heat-engines.....	8vo, 5 00
Kent's Steam-boiler Economy.....	8vo, 4 00

Durley's Kinematics of Machines.....	8vo,	4 00
Fitzgerald's Boston Machinist.....	16mo,	1 00
Flather's Dynamometers, and the Measurement of Power.....	12mo,	8 00
" Rope Driving.....	12mo,	2 00
Goss's Locomotive Sparks.....	8vo,	2 00
Hall's Car Lubrication.....	12mo,	1 00
Holly's Art of Saw Filing.....	18mo,	75
* Johnson's Theoretical Mechanics.....	12mo,	3 00
Johnson's Short Course in Statics by Graphic and Algebraic Methods. (<i>In preparation.</i>)		
Jones's Machine Design:		
Part I.—Kinematics of Machinery.....	8vo,	1 50
Part II.—Form, Strength and Proportions of Parts.....	8vo,	3 00
Kerr's Power and Power Transmission.....	8vo,	2 00
Lanza's Applied Mechanics.....	8vo,	7 50
MacCord's Kinematics; or, Practical Mechanism.....	8vo,	5 00
" Velocity Diagrams.....	8vo,	1 50
Merriman's Text-book on the Mechanics of Materials.....	8vo,	4 00
* Michie's Elements of Analytical Mechanics.....	8vo,	4 00
Reagan's Locomotive Mechanism and Engineering.....	12mo,	2 00
Reid's Course in Mechanical Drawing.....	8vo,	2 00
" Text-book of Mechanical Drawing and Elementary Machine Design.....	8vo,	3 00
Richards's Compressed Air.....	12mo,	1 50
Robinson's Principles of Mechanism.....	8vo,	3 00
Ryan, Norris, and Hoxie's Electrical Machinery. (<i>In preparation.</i>)		
Sinclair's Locomotive-engine Running and Management.....	12mo,	2 00
Smith's Press-working of Metals.....	8vo,	3 00
" Materials of Machines.....	12mo,	1 00
Spangler, Greene, and Marshall's Elements of Steam-engineering.....	8vo,	3 00
Thurston's Treatise on Friction and Lost Work in Machinery and Mill Work.....	8vo,	3 00
" Animal as a Machine and Prime Motor, and the Laws of Energetics.....	12mo,	1 00
Warren's Elements of Machine Construction and Drawing.....	8vo,	7 50
Weisbach's Kinematics and the Power of Transmission. (Herrman—Klein.).....	8vo,	5 00
" Machinery of Transmission and Governors. (Herrman—Klein.).....	8vo,	5 00
Wood's Elements of Analytical Mechanics.....	8vo,	3 00
" Principles of Elementary Mechanics.....	12mo,	1 25
" Turbines.....	8vo,	2 50
The World's Columbian Exposition of 1893.....	4to,	1 00

METALLURGY.

Egleston's Metallurgy of Silver, Gold, and Mercury:		
Vol. I.—Silver.....	8vo,	7 50
Vol. II.—Gold and Mercury.....	8vo,	7 50
** Iles's Lead-smelting.... (Postage 9 cents additional)	12mo,	2 50
Keep's Cast Iron.....	8vo,	2 50
Kunhardt's Practice of Ore Dressing in Europe.....	8vo,	1 50
Le Chatelier's High-temperature Measurements. (Boudouard—Burgess.).....	12mo,	3 00
Metcalf's Steel. A Manual for Steel-users.....	12mo,	2 00
Smith's Materials of Machines.....	12mo,	1 00
Thurston's Materials of Engineering. In Three Parts.....	8vo,	8 00
Part II.—Iron and Steel.....	8vo,	3 50
Part III.—A Treatise on Brasses, Bronzes and Other Alloys and Their Constituents.....	8vo,	2 50

MINERALOGY.

Barringer's Description of Minerals of Commercial Value.	2 50
Oblong, morocco,	2 00
Boyd's Resources of Southwest Virginia.....	8vo, 3 00
" Map of Southwest Virginia.....	Pocket-book form, 2 00
Brush's Manual of Determinative Mineralogy. (Penfield.)	8vo, 4 00
Chester's Catalogue of Minerals.....	8vo, paper, 1 00
Cloth,	1 25
" Dictionary of the Names of Minerals.....	8vo, 3 50
Dana's System of Mineralogy....	Large 8vo, half leather, 12 50
" First Appendix to Dana's New "System of Mineralogy."	Large 8vo, 1 00
" Text-book of Mineralogy.....	8vo, 4 00
" Minerals and How to Study Them.....	12mo, 1 50
" Catalogue of American Localities of Minerals.	Large 8vo, 1 00
" Manual of Mineralogy and Petrography.....	12mo, 2 00
Egleston's Catalogue of Minerals and Synonyms.....	8vo, 2 50
Hussak's The Determination of Rock-forming Minerals.	(Smith.) Small 8vo, 2 00
* Penfield's Notes on Determinative Mineralogy and Record of	Mineral Tests.....8vo, paper, 50
Rosenbusch's Microscopical Physiography of the Rock-making	Minerals. (Idding's.).....8vo, 5 00
* Tillman's Text-book of Important Minerals and Rocks.	8vo, 2 00
Williams's Manual of Lithology.....	8vo, 3 00

MINING.

Beard's Ventilation of Mines.....	12mo, 2 50
Boyd's Resources of Southwest Virginia.....	8vo, 3 00
" Map of Southwest Virginia.....	Pocket-book form, 2 00
* Drinker's Tunneling, Explosive Compounds, and Rock	Drills.....4to, half morocco, 25 00
Eissler's Modern High Explosives.....	8vo, 4 00
Fowler's Sewage Works Analyses.....	12mo, 2 00
Goodyear's Coal-mines of the Western Coast of the United	States.....12mo, 2 50
Ihlseng's Manual of Mining.....	8vo, 4 00
** Iles's Lead-smelting.....	12mo, 2 50
Kunhardt's Practice of Ore Dressing in Europe.....	8vo, 1 50
O'Driscoll's Notes on the Treatment of Gold Ores.....	8vo, 2 00
Sawyer's Accidents in Mines.....	8vo, 7 00
* Walke's Lectures on Explosives.....	8vo, 4 00
Wilson's Cyanide Processes.....	12mo, 1 50
Wilson's Chlorination Process.....	12mo, 1 50
Wilson's Hydraulic and Placer Mining.....	12mo, 2 00
Wilson's Treatise on Practical and Theoretical Mine Ventila-	tion.....12mo, 1 25

SANITARY SCIENCE.

Folwell's Sewerage. (Designing, Construction and Maintenance.)	8vo, 3 00
" Water-supply Engineering.....	8vo, 4 00
Fuertes's Water and Public Health.....	12mo, 1 50
" Water-filtration Works.....	12mo, 2 50

Gerhard's Guide to Sanitary House-inspection.....	16mo,	1 00
Goodrich's Economical Disposal of Towns' Refuse...	Demy 8vo,	3 50
Hazen's Filtration of Public Water-supplies.....	8vo,	3 00
Kierstedt's Sewage Disposal.....	12mo,	1 25
Leach's The Inspection and Analysis of Food with Special Reference to State Control. (<i>In preparation.</i>)		
Mason's Water-supply. (Considered Principally from a Sanitary Standpoint. 3d Edition, Rewritten....	8vo,	4 00
" Examination of Water. (Chemical and Bacteriological.)12mo,	1 25
Merriman's Elements of Sanitary Engineering.....	8vo,	2 00
Nichols's Water-supply. (Considered Mainly from a Chemical and Sanitary Standpoint.) (1883.)8vo,	2 50
Ogden's Sewer Design.....	12mo,	2 00
* Price's Handbook on Sanitation.....	12mo,	1 50
Richards's Cost of Food. A Study in Dieteries.....	12mo,	1 00
Richards and Woodman's Air, Water, and Food from a Sanitary Standpoint.....	8vo,	2 00
Richards's Cost of Living as Modified by Sanitary Science.	12mo,	1 00
* Richards and Williams's The Dietary Computer.....	8vo,	1 50
Rideal's Sewage and Bacterial Purification of Sewage.....	8vo,	3 50
Turneure and Russell's Public Water-supplies.....	8vo,	5 00
Whipple's Microscopy of Drinking-water.....	8vo,	3 50
Woodhull's Notes on Military Hygiene.....	16mo,	1 50

MISCELLANEOUS.

Barker's Deep-sea Soundings.....	8vo,	2 00
Emmons's Geological Guide-book of the Rocky Mountain Ex- cursion of the International Congress of Geologists.	Large 8vo,	1 50
Ferrel's Popular Treatise on the Winds.....	8vo,	4 00
Haines's American Railway Management.....	12mo,	2 50
Mott's Composition, Digestibility, and Nutritive Value of Food.	Mounted chart,	1 25
" Fallacy of the Present Theory of Sound.....	16mo,	1 00
Ricketts's History of Rensselaer Polytechnic Institute, 1824- 1894.....	Small 8vo,	3 00
Rotherham's Emphasised New Testament.....	Large 8vo,	2 00
Steel's Treatise on the Diseases of the Dog.....	8vo,	3 50
Totten's Important Question in Metrology.....	8vo,	2 50
The World's Columbian Exposition of 1893.....	4to,	1 00
Worcester and Atkinson. Small Hospitals, Establishment and Maintenance, and Suggestions for Hospital Architecture, with Plans for a Small Hospital.....	12mo,	1 25

HEBREW AND CHALDEE TEXT-BOOKS.

Green's Grammar of the Hebrew Language.....	8vo,	3 00
" Elementary Hebrew Grammar.....	12mo,	1 25
" Hebrew Chrestomathy.....	8vo,	2 00
Gesenius's Hebrew and Chaldee Lexicon to the Old Testament Scriptures. (Tregelles.).....	Small 4to, half morocco,	5 00
Letteris's Hebrew Bible.....	8vo,	2 25

