



Calhoun: The NPS Institutional Archive
DSpace Repository

Theses and Dissertations

1. Thesis and Dissertation Collection, all items

1987-03

**SFTYCHEF: A Consultative, Diagnostic Expert
System for Trench Excavation Safety Analysis
on Light Commercial Construction Projects**

Nicholas, Thomas C.

Pennsylvania State University

<http://hdl.handle.net/10945/41619>

Downloaded from NPS Archive: Calhoun



Calhoun is a project of the Dudley Knox Library at NPS, furthering the precepts and goals of open government and government transparency. All information contained herein has been approved for release by the NPS Public Affairs Officer.

Dudley Knox Library / Naval Postgraduate School
411 Dyer Road / 1 University Circle
Monterey, California USA 93943

<http://www.nps.edu/library>

DTIC FILE COPY

AD-A180 322



The Pennsylvania State University
The Graduate School
Department of Civil Engineering

SFTYCHEF: A Consultative, Diagnostic Expert System
for Trench Excavation Safety Analysis
on Light Commercial Construction Projects

Contract N00228-85-G-3278

A Report in
Civil Engineering
by
Thomas C. Nicholas

Submitted in Partial Fulfillment
of the Requirements
for the Degree of
Master of Engineering



This document has been approved
for public release and sale; its
distribution is unlimited.

DTIC
ELECTE
S APR 28 1987 D
A



Thomas C. Nicholas, LT, CEC, USN

27 4 1987

DISCLAIMER NOTICE

THIS DOCUMENT IS BEST QUALITY PRACTICABLE. THE COPY FURNISHED TO DTIC CONTAINED A SIGNIFICANT NUMBER OF PAGES WHICH DO NOT REPRODUCE LEGIBLY.

We approve the report of Thomas C. Nicholas

3/23/87

Date

[REDACTED]
J. H. Willenbrock,
Professor of Civil
Engineering, Bernard
Hankin Professor of
Residential Building
Construction, Report
Advisor

3/30/87

Date

[REDACTED]
M. S. Bronzini, Professor
of Civil Engineering,
Head of the Department of
Civil Engineering

Contract N00228-85-G-3278

RE: Copyright Notice
The Defense Technical Information Center
and the National Technical Information
Service have permission to reproduce and
sell this report
Per Ms. Lita Mosqueda, Naval Postgraduate
Schol, Code 031

Copies of the disk may be obtained from:
Naval Postgraduate Schocl, ATTN: Code 031,
Monterey, CA 93943-5100
Per Ms. Lita Mosqueda, NPS/Code 031



ABSTRACT

The development of a prototype knowledge-based expert system to assist safety analyses of short term, trench excavations on light commercial construction projects is presented.

Background information of trench excavation hazards, OSHA safety compliance regulations, in-the-field soils analysis techniques, timber shoring design, and expert system development is introduced. Detailed discussion of the design and construction of a knowledge base for the safety analyses of short term trench excavations is included along with the methods involved in loading the knowledge base onto an expert system shell.

TABLE OF CONTENTS

	<u>Page</u>
ABSTRACT.....	iii
LIST OF FIGURES.....	viii
CHAPTER	
1. INTRODUCTION.....	1
Introduction and Problem Statement.....	1
The Need for Trench Safety Research.....	1
Components of a Safe Trench Excavation.....	2
Applicability to Solution via Expert System.....	3
Background: Expert Systems.....	4
Definition of an Expert System.....	4
Sources of Knowledge for Trench Safety.....	5
Objectives.....	7
Research Methodology.....	8
Remarks on Literature Search.....	8
Method of Prototype Development.....	9
Scope and Limitations.....	10
Limitations of the Domain.....	10
Basis for Soils Analysis.....	11
Basis for Timber Shoring Design.....	11
Expert Interaction.....	11
Use of the System.....	12
2. AN OVERVIEW OF EXPERT SYSTEMS FOR CONSTRUCTION ENGINEERING AND MANAGEMENT.....	14
Introduction to Expert Systems.....	14
Definition.....	14
Composition.....	18
Utilization of Expert Systems in the Construction Industry.....	20
Proper Domains of Application.....	20
Early Applications.....	20
Construction Applications.....	21
CRITIC/ESRAM.....	22
AUGERPILE.....	23

	An Expert System for Shallow Trench Excavation.....	26
	Building An Expert System.....	28
	Problem Definition.....	28
	Knowledge Acquisition.....	29
	Knowledge Representation and Coordination...	30
	Inference Mechanisms.....	35
	Forward Chaining System.....	36
	Backward Chaining System.....	37
	Programming Skills.....	38
	Learning.....	39
	Expert System Shells.....	39
	Summary.....	43
3.	AN EXPERT SYSTEM FOR TRENCH SAFETY: THE PROBLEM.....	44
	The Need For A Proper Analysis of Soil Properties.....	44
	Traditional Approaches to Soil Analysis.....	44
	Determination of Lateral Earth Pressure.....	48
	Consolidated-Drained (CD) Test.....	52
	Determination of the Lateral Force on a Retaining Wall.....	57
	Field Methods of Soil Analysis.....	57
	Methods of Trench Wall Stabilization.....	65
	Bank Sloping.....	66
	Timber Frame Shoring.....	66
	Inconsistencies With Current Tabular Methods....	66
	Identification of Inconsistencies.....	66
	Explanation of Inconsistencies.....	69
	Affect On Expert System Development.....	71
	Elements of Trench Safety Not Related To Shoring	71
	Miscellaneous Safety Features.....	71
	Construction Site Practices.....	72
	Summary.....	73
4.	SFTYCHEF: AN EXPERT SYSTEM PROTOTYPE FOR TRENCH SAFETY ANALYSIS.....	74
	Problem Definition.....	74
	Knowledge Base.....	76
	Knowledge Acquisition.....	76
	Knowledge Representation.....	78

Language Implementation.....	81
Inference Structure/Chaining Mechanism.....	84
Explanatory Capabilities.....	86
Confidence Factors.....	88
Incomplete Knowledge.....	90
Addition of New Knowledge.....	90
Summary.....	91
5. SFTYCHEF: A TUTORIAL.....	92
Summary of Key Points.....	92
Scenario.....	94
Tutorial Run.....	95
User's Instructions.....	95
Screen Analysis.....	97
Summary.....	165
6. CONCLUSIONS AND RECOMMENDATIONS.....	166
Summary.....	166
Problem Domain.....	166
Suitability for Expert Systems.....	166
Construction of SFTYCHEF.....	167
SFTYCHEF.....	168
Current Stage of Development.....	168
Needed Work.....	168
Modification.....	170
Areas for Future Research.....	170
EXSYS.....	172
Strengths.....	172
Forward or Backward Chaining.....	172
Multiple Modes of Certainty.....	172
Automatic Rule Checker.....	173
Merging Two Distinct Rule Bases.....	173
Interfacing With Lotus 1,2,3.....	173
Rule/Memory Capacity.....	173
Shrink/Faster.....	174
Simplicity of Use.....	174
Weaknesses.....	174

Interacting with External Programs.....	174
Inability to Utilize Certainty	
Factors Below First Level.....	174
Inability to Call a Rule From a Rule...	175
Overwhelming Explanatory Data.....	175
Potentials of Joint Research.....	176
REFERENCES.....	177
APPENDIX I: EXPERT SYSTEMS AND THEIR APPLICATIONS.....	182
APPENDIX II: EXPERT SYSTEM SHELLS: INFORMATIVE DATA FOR PURCHASE.....	184
APPENDIX III: CORRESPONDENCE WITH DR. YOKEL OF NBS.....	188
APPENDIX IV: SFTYCHEF RULES 015 - 020.....	200

LIST OF FIGURES

<u>Figure</u>		<u>Page</u>
1.1	Sample Expert System Rule.....	6
2.1	Augerpile Rule Using INSIGHT Expert System.....	25
2.2	Similar Rule In FRANZ LISP.....	26
2.3	Example of Semantic Net Representation.....	31
2.4	Stages of Knowledge Acquisition.....	33
2.5	Methods of Automated Knowledge Acquisiton.....	34
3.1	Triangular Soil Classification Chart.....	45
3.2	AASHTO Classification System.....	46
3.3	Unified Soil Classification System.....	47
3.4	Lateral Earth Pressure as a Function of Vertical Earth Pressure.....	49
3.5	Variation of K_o with OCR for Some Soils.....	51
3.6	(CD) Direct Shear Test.....	53
3.7	Results of Direct Shear Test.....	54
3.8	Mohr's Circle Plot of Shear Test.....	55
3.9	Derivation of K_a	56
3.10	Variations in Lateral Earth Pressure.....	58
3.11	Estimating Lateral Soil Pressure.....	59
3.12	OSHA 1926 Table P-2.....	61
3.13	Matrix Classification System.....	62
3.14	Lateral Weight Effects.....	63
3.15	Rectangular Pressure Diagram.....	64
3.16	Allowable Sloping Configurations.....	67
3.17	Typical Timber Shoring Design.....	68
4.1	Wall Chart Schematic: Primary Subgoal Level...	79

4.2	Summary of the Factors Involved in Each of the Safety Analysis Subgoals.....	80
4.3	Sample Qualifiers.....	82
4.4	Sample Rule Using Qualifiers #X and #Y From Figure 4.3.....	83
5.1	Scenario Sketches.....	96

CHAPTER 1

INTRODUCTION

Introduction and Problem Statement

The Need for Trench Safety Research

In September of 1985, the Occupational Safety and Health Administration commenced a nationwide "special emphasis" inspection program aimed at combatting alarming fatality rates in construction trench excavations. Within one year, 1,764 trench inspections resulted in over 2,800 citations for safety violations (58). Unfortunately, it is questionable whether this statistic is a trend indicator or merely the reflection of common practice viewed closely for the first time. Each year hundreds of construction workers are injured or killed on the jobsite due to trench wall cave-ins, slides of spoil bank material into the trench, drownings in the trench, and other mishaps which are the result of a lack of proper consideration for safe construction practices. Although the problem is not a new one, there is as yet no obvious method that will guarantee a safe trench. In addition, the expertise needed to provide case by case analyses of soil type, lateral earth pressures, and retaining structure design is often too expensive or unavailable to the small contractor. Often the only safety considerations

provided are the result of concerned and knowledgeable, though technically inferior, field supervisors.

Components of a Safe Trench Excavation

The construction of a safe trench stems from an in-depth consideration of four factors:

1. A soils analysis must be made and supplemented with knowledge of site conditions. Traditionally, the goal of this analysis was to determine cohesion, angles of internal friction, depth of the water table, layering of differing soils, and other factors so that lateral earth pressure equations and diagrams could be developed and retaining structures designed based upon the results. The time and cost of such studies, however, have made them unattractive to the small contractor involved in short-term operations.
2. An adequate method of trench wall stabilization must be developed. Three main techniques exist to perform this task. The wall can be removed by sloping of the trench banks, the wall can be actively restrained by applying lateral pressure via timber frame or hydraulic shores, or the wall stabilization can be neglected and the workers

protected by using protective coverings such as trench boxes.

3. The existence of any job dependent construction activities which will influence trench stability must be considered. Such practices include: the operation of heavy equipment; drilling and blasting adjacent to the trench excavation; excessive pumping or dewatering; and excavating adjacent to existing foundations.

4. Attention must be given to all the miscellaneous safety features which job conditions may dictate. Respiratory protection, dust reduction, noise protection, ramp, ladder and walkway construction, and hazard awareness marking are but a few of the features that may be required.

Applicability for Solution via Expert System

An adequate solution to this problem cannot be generalized for all trenches on all construction projects. The problem has certain characteristics, however, which will allow an encompassing solution using a very new and interesting technology. The expertise exists and is available to provide a proper safety analysis in all situations. As various safety records attest, the solutions developed by professionals have been proven to be better than

those of experienced field supervisors. The solution for most trench excavation situations is not lengthy. An expert, given the proper information, could provide the necessary solution in a matter of hours. As was previously mentioned however, the problem is often ill-structured. Seldom do two jobs have identical conditions or requirements. In addition, the expertise is often derived from subjective knowledge. Solution of this problem has a very high payoff; the number of jobsite fatalities can be reduced. These characteristics make the problem ideal for the application of expert system technology.

Background: Expert Systems

Definition of an Expert System

"Expert System" is not a very familiar term for many civil engineers. To those who have done casual reading in artificial intelligence, it may summon images of futuristic, computerized managers, capable of decision making and supervision of a variety of tasks. Although such conceptualization can be defended, the reality of expert systems is more practical.

Fundamentally, an expert system is a computer system consisting of a central processing unit, a terminal, a screen, a printer, and a software package which embodies the knowledge of an expert to assist a user in making expert level decisions. The expert knowledge consists of a

collection of facts held in a database and a set of rules which relate these facts. Figure 1.1 presents an illustration of one such rule.

As the user inputs information at the terminal about the problem, the computer records the information, selects appropriate facts from the database, validates certain conditions, and then selects and applies the rules which the conditions satisfy. In this manner, the system proceeds or chains through its rules until final actions or a solution is reached. Chapter 2 will provide an elaboration on the history of, the application, and the design of expert systems.

Sources of Knowledge for Trench Safety

The power of an expert system is wholly dependent upon the quality of the knowledge encoded in the database. For the problem at hand, or domain of application, the knowledge has been drawn from a number of sources.

In order to provide guidance and legal standards for safe trench excavation operation, OSHA developed the Code of Federal Regulations, 29 CFR 1926/1910, Subpart P (61), which deals with construction safety for excavations, trenching, and shoring. This publication is a segment of the Code of Federal Regulations (CFR) 1926/1910 (61) which provides safety standards for the construction industry. OSHA 1926

RULE NUMBER: 137

IF:

- (1) The class of soil is type III
- and (2) The depth of the trench is 10-15 feet or 15-20 feet or 20+ feet

THEN:

- (1) [We] IS GIVEN THE VALUE 60
- and (2) [SLOPE] IS GIVEN THE VALUE "(1 1/2 : 1)"

NOTE: If there is any indication of general or local instability, slopes shall be cut back to a slope which is at least 1/4 Hor : 1 Vert. flatter than the stable slope.

REFERENCE: NBS Building Science Series 127, Recommended Technical Provisions for Construction Practice in Shoring and Sloping of Trenches and Excavations, Table 3.3, Minimum Acceptable Stability Requirements for Matrix System.

Figure 1.1 Sample Expert System Rule

was last revised in 1979. Although this document is the law, a number of other organizations have published supplementary standards and directives. EM 385-1-1, Section 23 (60), is the document utilized on many military and government jobsites. Technical research done by the National Bureau of Standards so that OSHA 1926 might be updated led to four very useful publications. NBS, BSS 121, Soil Classification for Construction Practice in Shallow Trenching (56); NBS, BSS 122, A Study of Lumber Used for Bracing Trenches in the United States (57); NBS, BSS 127, Recommended Provisions for Construction Practice in Shoring and Sloping of Trenches and Excavations (58); and NBS/NIOSH, Development of Draft Construction Safety Standards for Excavations (59) contain very useful expertise. It is from these documents that a contractor would draw the information necessary to construct and operate a safe trench. This information has been used to compile a knowledge base to be utilized by the expert system.

Objectives

The following five objectives provide the framework for this research effort.

1. The collection and structuring of the body of knowledge utilized in the domain of safety in trench excavations.

2. An in-depth investigation of applicable expert system domains from the realm of civil engineering and construction.
3. A presentation of basic expert system design and construction methods to provide a starting point for other researchers in construction.
4. The development of a prototype expert system to provide consultative advice to contractors involved in trench excavation operations on light commercial construction projects.
5. Identification of the areas of expert system research, in construction, which need to be explored in greater detail.

Research Methodology

The principal methods utilized to accomplish the five objectives were literature search, formal classroom study, non-structured interviews with experts in expert system design, and hands-on application of expert system software.

Remarks on Literature Search

Objectives 1, 2, and 3 were covered primarily via literature search but several remarks need to be made.

Although knowledge can be collected from various sources of varying reliability, its representation or structure is vital to the success of expert system implementation. Knowledge representation is not a concept to be taken lightly and the techniques utilized cannot be learned from a literature search. The techniques available and those attempted will be discussed in Chapters 3 and 4. An explanation of applicable expert system domains and a presentation of design skills and methods can only be made after hours of time have been spent on the computer attempting to implement a variety of ideas. There is a mistaken concept prevalent among many engineers that expert system development requires extensive domain knowledge and enough computer background to understand the written literature. Any research effort in the area of expert systems requires considerably more computer science knowledge than an engineer typically acquires in undergraduate or graduate studies. Expert Systems are among the state of the art in computer systems in artificial intelligence. This paper could not possibly detail the computer background mandated by such research. Let it be sufficient to say that an extensive portion of the research methodology must be devoted to learning skills which are often outside the researcher's area of expertise.

Method of Prototype Development

The development of the prototype, SFTYCHEF, was accomplished via interaction with EXSYS, an expert system

shell produced by EXSYS Incorporated of Albuquerque, New Mexico. The particulars of expert system shells and the techniques utilized in loading such a shell are contained in Chapters 4 and 5.

Scope and Limitations

It is important at the outset of this report to identify the boundaries within which this research was conducted and to provide overall guidance concerning the use of the developed prototype.

Limitations of the Domain

The domain of application is the safety analysis of trench excavations on light commercial construction projects. These trenches are typically limited to those less than 20 feet deep and open for a period of 24 hours or less. These parameters of 20 feet of depth and 24 hours of open time are critical factors in the following analysis. Dr. Felix Yokel (58) has determined that trenches of a greater depth and open for a longer time exhibit significantly different stability characteristics. The stabilization methods investigated and included in the prototype are timber shoring and bank sloping. The system does not include any knowledge of trench jacks, hydraulic shores, trench boxes, sheet piling, thermal stabilization or other stabilization techniques. The addition of any or all of these to SFTYCHEF would not be

technically difficult and will be discussed in Chapter 5. The reason for their exclusion is that each method by itself is worthy of its own research study and the amount of knowledge to be covered greatly exceeds the time constraints of this research and the memory and processing capabilities of the expert system shell.

Basis for Soils Analysis

The determination of soil type and lateral earth pressures are based on the Matrix Classification System developed by the National Bureau of Standards (56).

Basis for Timber Shoring Design

The timber shoring design recommendations are based on OSHA 1926, Subpart P, Table P-2 (61). Although there are questions regarding the accuracy of this table, it remains the legal standard to which contractors are held, thus it was not modified. A discussion of potential errors and suggested revisions are presented in Chapter 5.

Expert Interaction

The development of an expert system typically requires several months of interaction between the system designer, or knowledge engineer, and selected experts. Such interaction mandates that an expert or experts in the domain of application be dedicated to system development. Attempts were made to involve experts from OSHA's regional office in

Philadelphia, OSHA's field office in Harrisburg, the Naval Facilities Engineering Command in Washington, D.C., and the Army Corps of Engineers Construction Engineering Research Laboratory in Champagne-Urbana, Illinois. Although some were more cordial than others, no one was willing to dedicate the time of an expert to such research. Therefore, the majority of the knowledge included in this prototype is textual. It should be noted that the full-time involvement of an expert is one of the hidden costs of system development. Rarely, if ever, can a valid system be built without continuous expert interaction. A weekly meeting or spot interviews will not suffice. SFTYCHEF, though accurate and justifiable, could have been improved greatly if there had been more active expert interaction.

Use of the System

Emphasis needs to be placed on the words "consultative" and "prototype" in the system description. SFTYCHEF was designed to assist decision making and to educate its user. It will not replace an expert nor will it serve as a professional engineer. The system is prototypical in that much work remains to be done before such a system can be applied by construction project personnel.

At this point, the limitations imposed may seem to greatly restrict the system's performance. The remainder of this paper should clarify the need for such restrictions and provide guidance for their removal. Chapter 2 will highlight

the use of expert systems in construction and will provide introductory instruction concerning system development. Chapter 3 will look closely into the problem of trench safety analysis and will concentrate on soils analysis, timber shoring design, slope stabilization, construction site practices, and miscellaneous safety features. Chapter 4 will then detail how this information was represented and encoded to create SFTYCHEF. The final two chapters will give specific guidance to users and future researchers.

CHAPTER 2

AN OVERVIEW OF EXPERT SYSTEMS FOR CONSTRUCTION ENGINEERING AND MANAGEMENT

Introduction to Expert Systems

Definition

The widespread applicability of microcomputers to the construction industry has prompted extensive software development in a variety of areas. Design, material procurement, finance, scheduling, and quality control, to name a few, are widely supported by software packages and their associated hardware. Recently, a new type of computer system has gained prominence in construction, as well as in other fields of civil engineering. These systems have their roots in artificial intelligence and are commonly known as expert systems.

As was mentioned in Chapter 1, an expert system is a computer system which utilizes expert knowledge to assist its operator in making expert level decisions. In order to build on what has already been discussed, let us look at a very simple example of how facts and rules interrelate in a decision making situation. Consider an engineer trying to determine the suitability of using a compacted soil base for

supporting a concrete slab. The system database may contain information on soil types, compaction techniques, suitability for foundations, and various standard specifications. It would also include rules, such as, "IF the compaction achieved exceeds 95% of the optimum at a specified moisture content, THEN the soil is suitable for slab placement." The user would volunteer any information he has about the actual conditions on the project under consideration and the system would prompt him for further information, and perhaps recommend the tests and methods to be used if additional information is necessary. As the information is acquired, the system selects the applicable rules and fires¹ them to make the appropriate decision.

Conceptually, the technique is not particularly abstract. Its use applies to any problem which requires expertise that is not readily available. Although at this stage, the development and implementation may seem easy, further exploration quickly reveals that this is not so.

A more specific definition of what characteristics comprise an expert system depends greatly upon the author who is providing the definition. All sources, however, seem united on identifying the following seven characteristics.

1. EXPERTISE - The most important goal in expert system work is to attain the high level of performance that a human

¹The validation of the truth of a rule is known as FIRING the rule.

expert achieves in some task (26). This inherently implies that such a system must know what the expert knows. It also means that the system should behave like an expert, producing high quality results in minimal time, employing skills developed through years of experience, and utilizing well founded hunches to quickly eliminate false conclusions. High quality results are simply results that are right, but as can easily be imagined, problems unfold quickly when right and wrong answers are not known or when multiple right answers exist. The utilization of hunches to perform block elimination is referred to as inferential leaping. An expert, when confronted with a problem, does not perform an algorithmic search and test of every possible solution, but instead narrows the field of solutions in large blocks based on his past experience. Such ability is often cited as the difference between an expert and a skilled technician.

2. SYMBOL MANIPULATION - An expert system represents knowledge symbolically. The matching or relational linking of these symbols to derive new inferences is called symbol manipulation.

3. GENERAL PROBLEM SOLVING ABILITY IN A DOMAIN - An expert system must possess the ability to reason from first principles. For example, if the system spoken of earlier was prompted with the query "why?" following its inference on the suitability to pour the concrete slab, it should be able

to provide the elementary knowledge of soil type, testing procedures, and reasoning used to support the validity of 95% compaction implying suitability. It is worth noting that systems which provide expert answers in series response to pre-asked questions are not difficult to design and are not expert systems.

4. COMPLEXITY / DIFFICULTY - Perhaps relating more to the definition of expert, if the domain over which the system is defined is not somewhat complex, then true expertise does not exist and the system is not expert.

5. REFORMULATION - A distinguishing characteristic of an expert is the ability to restructure a problem in a form which has been dealt with previously. This ability is termed reformulation.

6. REASONING ABOUT SELF - An expert system contains knowledge about what it knows (meta-knowledge). It must also have the capability to remember/reconstruct the paths of inference followed while reaching a decision.

7. TASK - At this point in time, expert systems are highly task oriented. They are not capable of abstract reasoning. The system exists to solve a particular set of problems in a well defined domain.

Although these seven elements are present in varying

degrees in most expert systems, the technological difficulties involved have thus far precluded any well publicized system from embodying all seven elements to their fullest extent. Many other characteristics of these systems, such as common sense capabilities, reasoning by analogy, and learning from experience (i.e. becoming more expert) could be added to the list of seven but their necessity in defining an expert system is not well justified.

Composition

To this point, the function of an expert system has been briefly defined and the performance characteristics of an expert system have been described. The specific components of an expert system have not yet been revealed. When one looks closely at the composition of an expert system, one finds:

1. KNOWLEDGE CONSISTING OF DOMAIN RELATED FACTS - This knowledge is called declarative knowledge. It establishes the existence of facts within the database upon which the system must rely.

2. KNOWLEDGE CONSISTING OF DOMAIN RELATED RULES - This knowledge is called procedural knowledge. It relates the facts in an IF-THEN format so that inferences can be drawn. Declarative knowledge and procedural knowledge are both a combination of deep knowledge, that based upon scientific

fact, and surface knowledge, that based upon personal experience. Surface knowledge is commonly known as heuristic knowledge or rules of thumb.

3. AN INTERPRETER THAT APPLIES THE RULES - The system contains a mechanism that selects the applicable rules from the knowledge base. The selection is initially based on user input.

4. AN ORDERING MECHANISM - After the interpreter has selected the pertinent rules, the ordering mechanism establishes the flow pattern to be followed. This ordering is critical to the derivation of valid and justifiable conclusions. The interpreter and the ordering mechanism are often termed the "inference engine" of the system.

5. CONSISTENCY ENFORCER - A consistency enforcer insures that inferences are drawn in a consistent manner and that procedures do not change with the addition or deletion of knowledge from the database.

6. JUSTIFIER - The user of the system often considers the justifier to be the most valuable component. It retraces the paths of inference in an effort to explain its conclusion to the user. A system which produces obvious results or surprising results without justification is neither expert nor valuable.

Utilization of Expert Systems in the Construction Industry

Proper Domains of Application

When considering the application of an expert system to a particular problem domain, it is necessary to insure that experts exist in that domain. Perhaps this seems obvious but it is important to note that expert systems can only be utilized when a high level of expertise exists. This is unfortunate. There are many fields of science and technology which cannot benefit from such a system because the level of expertise is too limited.

The domain of application must be one in which experts are provably better than amateurs so that expert performance can be verified. The problem to be solved should be solvable in a time span of several minutes to several hours. The problem should be ill-structured and the solution somewhat cognitive. A problem solvable by rigorous application of mathematical algorithms is inappropriate.

The development of an expert system must also have a high payoff. The development of a major system takes years and often millions of dollars. The results obtained must justify the expenditures.

Early Applications

With these thoughts in mind, B.G. Buchanan developed a

pioneer system in 1965 known as DENDRAL (6). DENDRAL defined the fundamental concepts of expert systems by utilizing a database of expert, heuristic knowledge to infer molecular structure from mass spectrographic data. The system, though later modified, has proven very reliable.

CASNET (65), developed in the early 1970's, assists doctors in their diagnosis and treatment of glaucoma patients. It advanced expert system technology by successfully encoding probabilistic rules within its knowledge base to provide confidence factors for the answers that were generated.

Perhaps the most heralded of the early systems is MYCIN (50). Developed in the mid-1970's, it gives consultative advice on diagnosis and therapy of infectious, bacteriological, diseases. Two of its offspring, EMYCIN (63), and TEIRESIAS (14), have also been highly acclaimed. EMYCIN is an expert system that assists expert system development, and TEIRESIAS is an expert system that can acquire, modify, and format new knowledge to update MYCIN.

Since these early systems, the realm of applications has exploded and includes systems that teach, monitor, repair, design, plan, predict, diagnose, interpret, debug, and control. Appendix 1 provides a partial listing of the systems developed to this point along with their applications.

Construction Applications

Many of the system applications relate closely to

problems experienced in the construction industry. The use of expert systems to handle such problems is still in its infancy however, and most construction systems are still prototypes.

CRITIC/ESRAM. The U.S. Army Corps of Engineers builds and maintains thousands of miles of railroad track in this country. They employ numerous engineers who serve as quality control inspectors in this area and a major problem they face is inspecting and detecting deteriorating subbases and recommending feasible solutions. Since there is a shortage of experienced inspectors, the Corps wanted an expert system to act as a consultant for the field inspector. The system, developed by the Construction Engineering Research Laboratory, CERL, which is called CRITIC/ESRAM (32), allows the inspector to input field conditions into the system and obtain a series of analyses and courses of action. The system not only alleviates much of the inexperience among inspectors but also provides continuous, interactive tutoring of the inspector, thereby increasing his expertise.

CRITIC is Pascal driven and operates under the UCSD P-System DOS² package on a variety of microcomputers. Its strongest points are its excellent explanatory capabilities and user friendliness. The system first explains its command options to the user and details the appropriate time to issue each particular response. The system then leads the user

²University of California, San Diego P-System Disk Operating System.

through a consultation. It asks the user to provide information on moisture content, pumping, ditches, settlement, and other pertinent information, explaining each request if necessary. When the system has gained enough knowledge to output a recommendation, it does so, along with displaying all rules selected and tested and the effect of each on the solution. CRITIC is a functioning expert system which, though not large in scale, provides needed assistance to field inspectors.

AUGERPILE. The majority of main-frame expert systems developed have cost a considerable amount of money. The result has often been a very powerful improvement of a system which could have been implemented on a microcomputer. Occasionally though, the system developed is not cost effective. Nitin S. Pandit and D. Sriram of Carnegie-Mellon University (31) have approached this problem by taking potential main-frame systems and implementing them first on a microcomputer to establish their potential worth before committing to large expenditures. One such system is AUGERPILE (31).

AUGERPILE is an expert system designed to aid in the field inspection of augered, cast-in-place, concrete pile installations. It uses an expert system shell known as INSIGHT (30). Such a shell is essentially an expert system with the knowledge base removed. Shells will be discussed in greater detail later in this chapter.

Augered, cast-in-place piles are a specialized form of

deep foundation. They are friction piles, transferring a load from a superstructure to the soil via frictional resistance between the soil and the pile surface. They are best suited to areas where the soil is too soft to use more conventional methods. These piles can support loads of up to 100 tons.

The installation of these piles is not complex. Usually the necessary resources are an adapted drilling rig, one operator, a foreman, an inspector, and the materials. The operator augers a hole without excavation using a hollow auger. While raising the auger, grout (cement, aggregate, fluidifiers, additives, and water) is pumped through the hollow auger stem. The problem most often encountered is necking. Necking is the bulging or constriction of the diameter of the pile in areas where soft, loose, water bearing soil exists or where man-made fill leaves unexpected voids.

The inspection of this operation is difficult because observations can only be made from the surface. Load tests and pullout tests are elaborate and expensive. Acoustical monitoring and geophysical methods provide data that is too uncertain to make a quality control analysis. The inspection is a highly judgement prone process. Results obtained by an inexperienced inspector or contractor are unreliable.

AUGERPILE serves as a consultant which prompts the inspector to view five areas of the installation in great detail. Based upon the inspector's description of the

operation, a determination of successful placement is made.

A sample rule from AUGERPILE, shown in Figure 2.1, illustrates the user friendliness of systems built with shells. Figure 2.2 is a comparable rule written in FRANZ LISP for another system. FRANZ LISP is an adaptation of LISP (LISt Programming) which is used extensively at the Massachusetts Institute of Technology (31).

RULE: Final Judgement

```
IF:  equipment was OK
      AND:  starting conditions were OK
      AND:  grout mix was OK
      AND:  installation so far was OK
      AND:  steel installation was OK
THEN: Augerpile installation passed
      AND:  Display pass
ELSE: Augerpile installation failed
      AND:  Display fail
```

FIGURE 2.1 AUGERPILE RULE USING INSIGHT EXPERT SYSTEM
SHELL (31, p. 20)

RULE 3: TRIANGULAR LOAD

```
(if(?load is triangular)
  then
    (list 'load'*
      (list 'rloc' - 'lloc)
      '*0.5))
```

FIGURE 2.2 SIMILAR RULE IN FRANZ LISP
(31, p. 35)

An Expert System for Shallow Trench Excavation. Recently, researchers at Carnegie-Mellon completed work on a report which parallels the writer's work in many respects. In April of 1986, G.M. Konkoly, D.R. Rehak, and P.P. Christiano (10) released a technical report summarizing work on a prototype expert system for shallow trench excavation.

The research effort was constructed around two main objectives. First, it was hoped that a Knowledge Base Expert System (KBES) could be developed which would assist construction foremen in applying the new soil analysis and trench shoring standards developed by the National Bureau of

Standards (56). The approach taken by NBS to soil classification led to the development of two new methods, the Matrix Classification System and the Simplified Method (56). Both of these methods provide the construction foreman with a systematic, non-laboratory procedure for classifying soil types. This classification can then be used to identify the proper design for a timber frame shoring system.

The report also addressed two prominent issues in current expert system literature, knowledge acquisition, and the selection of an appropriate KBES environment. G.M. Konkoly was fortunate enough to work directly with Dr. F. Yokel (58) at NBS. Dr. Yokel headed the study to revise the OSHA trench shoring standards. The period of interaction is well documented in the report and it provides valuable insight into some of the difficult aspects of knowledge acquisition. Konkoly then did a comparative analysis of the compatibility of the trench shoring domain with OPS-5 (23), INSIGHT (30), and PERSONAL CONSULTANT (45), three commercially available expert system shells. The research effort led to the use of PERSONAL CONSULTANT for her work.

The outcome of the research was a prototype expert system which utilizes both the Matrix Classification System and the Simplified Method to perform an "in-the-field" soil analysis. The report proposes expansion of the system to incorporate timber frame shoring design, hydraulic shoring usage, trench jacking, and the installation of trench boxes. In depth background information on the theory of soils,

trenches, and braced excavations is provided in the report. The difficulties inherent in the design of timber frame shoring are thoroughly discussed. The work at CMU provided essential background to the research in this report. The Matrix Classification System forms an integral part of SFTYCHEF, a prototype expert system introduced in Chapter 4 of this report.

The examination of systems to this point was approached from a problem domain point of view so that an appreciation could be gained for the types of work expert system can do. The section below will examine how such systems are built.

Building An Expert System

D.A. Waterman (26), noted co-author of the text. Building Expert Systems has stated, "Choices regarding the desired initial capabilities determine what knowledge to acquire first and how to engineer it for use."

Problem Definition

It was previously mentioned that expert systems are task oriented, built to solve a particular problem. The initial step in building an expert system is to define the problem. Current methods of solution should be studied. A very close look at applicable expert system domains must be made. Are there experts in the field? Are the experts provably better than amateurs? What is the duration of a typical problem

solution? Is the problem ill-structured and somewhat cognitive? Are inferences drawn from subjective knowledge? Does the solution via expert system offer a high payoff? A well focused problem leads to a well focused solution. Expert systems are not capable of creative thinking. If data has been left out of the knowledge base, it can't be used to draw inferences.

Knowledge Acquisition

Once the problem has been defined as a problem worthy of expert system technology, a knowledge engineer commences the process of knowledge acquisition, representation, and coordination. A knowledge engineer is an expert at the techniques used to gather information and to represent it in an implementable code.

The knowledge engineer begins by familiarizing himself with the problem. He locates the sources of expertise, such as books and people, and visits those most familiar with the problem. During this period of familiarization, he characterizes the problem solution as either: (1) interpretation, (2) diagnosis, (3) monitoring, (4) prediction, (5) planning, or (6) design. He then meets with the expert or experts who will assist him throughout the project in order to review the parameters established during the problem definition phase.

The knowledge engineer may spend several months in meetings with the expert(s). During this time, the engineer

is attempting to acquire the facts that the expert knows about the problem solution and what basic solution strategies the expert utilizes. These facts and strategies are the foundation for the knowledge base. The knowledge acquired at this point also forms the basis for the system's explanatory capabilities.

Knowledge Representation and Coordination

As the knowledge engineer collects information, he structures it, or represents it in a manner that makes the relationships between data items more apparent. Knowledge representation is a field of study in itself but an overview is essential to a basic understanding of the design process.

One technique used to represent knowledge is STATE-SPACE representation. Each data item is assigned a given location at a particular time, much like the pieces on a chess board during a game. Their interrelationships are determined by their locations at a given time. A more common representation scheme is SEMANTIC NETS. Semantic nets group similar data into object classes and display relationships between these classes as linkages. (See Figure 2.3)

LOGIC REPRESENTATION is yet another way to represent facts and their relationships. Logic representation includes first order predicate calculus, frame representation, entity-relationship diagramming, network diagramming, and hierarchical diagramming.

Predicate calculus uses logic statements to represent facts and axioms in predicate form. Inferences can be drawn from the two. For example, let us represent the fact that all CAT 651B's are scrapers. In predicate calculus it would be stated as follows: $CAT_651B(x) \rightarrow SCRAPER(x)$. An axiom such as "All scrapers require maintenance every 40 hours" may look like $x.SCRAPER(x) \rightarrow 40_MAINT(x)$. This expression is read, "For all x, such that x is a scraper, x requires 40

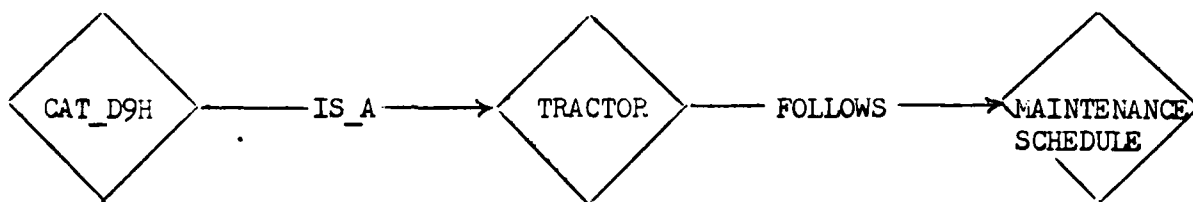

FIGURE 2.3: EXAMPLE OF SEMANTIC NET REPRESENTATION

hour maintenance." From these two predicate representations, the system could derive the inference $CAT_651B(x) \rightarrow 40_MAINT(x)$. This is, of course, a very simple example but it illustrates one way that facts are represented so that a new fact can be inferred. For an in-depth treatment of

entity-relationship diagramming, network diagramming, or hierarchical diagramming, the interested reader is referred to Principles of Database Systems by J.D. Ullman (55) and An Introduction to Database Systems by C.J. Date (13).

After the knowledge engineer has represented the facts and their interrelationships, he must formulate the rules which connect various facts and axioms in every situation to be considered. Figure 2.4 illustrates the knowledge acquisition, representation, and coordination tasks as seen by Waterman (26).

The evolution of expert system technology has suggested the possibility of performing this entire process without using a knowledge engineer. Methods of automated knowledge acquisition are shown in Figure 2.5. One such possibility uses an intelligent editing program that converses directly with the expert and collects, represents, and coordinates knowledge, and implements it for use. Another method uses a program which takes data from case histories as input and formulates the knowledge base. A third technique would be to use text understanding software to gather data directly from textbooks.

All knowledge in its final form must undergo extensive testing to assure the validity of all inferences drawn. This critical process is often long, repetitive, and difficult. Problems arise from many sources. There is often a discrepancy between the way an expert says he solves a problem and the way he actually solves it. In such a

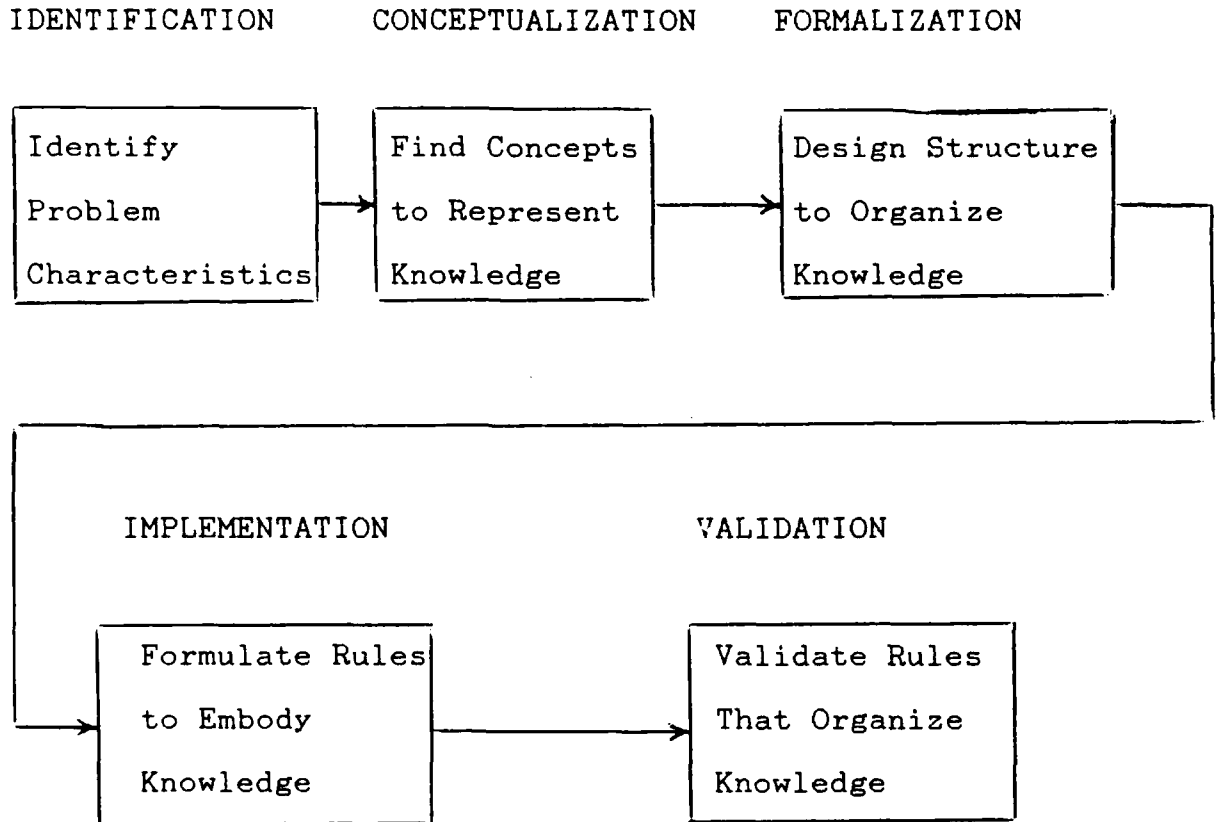

FIGURE 2.4 STAGES OF KNOWLEDGE ACQUISITION

(26, p. 139)

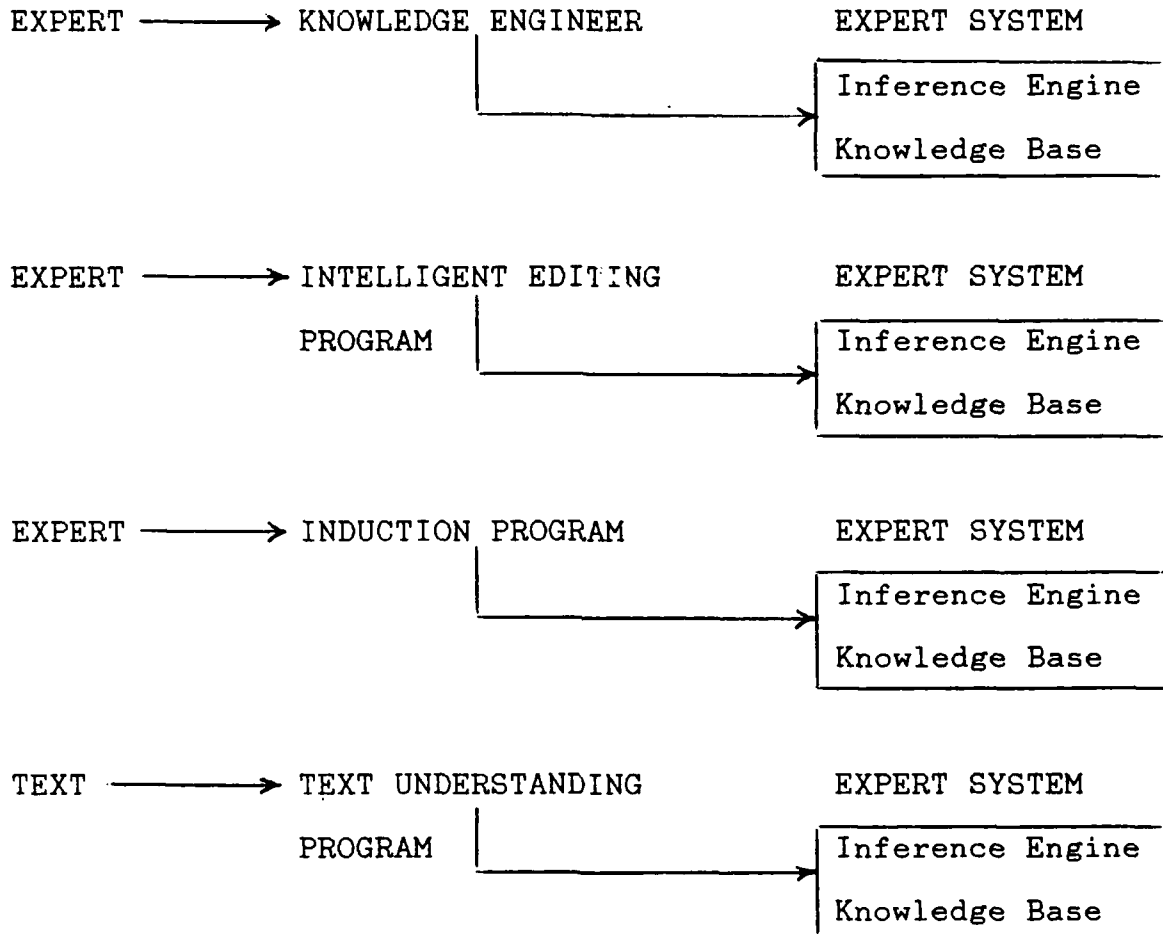

FIGURE 2.5 METHODS OF AUTOMATED KNOWLEDGE ACQUISITION
(26, pp. 130-132)

mismatch, the program logic must be changed to match the expert's technique, not his explanation. In some instances, experts are not able to verbalize their expertise. A third difficulty occurs during system validation when an obvious wrong answer is provided and the system must be traced. At this stage of development, a system has no self tracing capability so a hand trace must be made of all possible logic paths to identify the error. Such a process is tedious.

Inference Mechanisms

Once the knowledge base has been validated, an inference mechanism must be developed. Recall that the inference mechanism consists of an interpreter which selects the rules to be fired, and an ordering mechanism that decides in what order the rules are to be fired. According to Fox (24), the four primary inference mechanisms in use today are:

1. HEURISTIC SEARCH
2. ANALYTICAL TOOLS (Linear Programming, Dynamic Programming, Queuing Theory)
3. CONSTRAINT DIRECTED REASONING
4. HIERARCHICAL REASONING

All of these mechanisms share common characteristics. Each utilizes some sort of chaining, either forward or backward, to move through the rules. A simple example may help explain the difference between forward and backward

chaining.

Forward Chaining System

When forward chaining, the system takes the input and searches the knowledge base for a matching predicate. It selects those rules whose predicates match, fires them, and looks for new predicates to match the newly validated objects. It continues to do this until a solution is reached.

USER INPUT: Is the subbase suitable for slab placement?

SYSTEM RESPONSE: What is the compacted elevation, in
feet?

USER INPUT: 1206

SYSTEM (RULE 1): If grade elevation = specified
elevation, then check compaction.

SYSTEM RESPONSE: What is the compacted density (%) ?

USER INPUT: 95

SYSTEM (RULE 43): If compaction \geq 95, then subbase is
suitable for slab placement.

SYSTEM RESPONSE: The subbase is suitable for slab
placement because the compacted
elevation equals the specified
elevation and the compacted density
is \geq 95% .

As can be seen, forward chaining essentially is "data driven", the next question being determined by the response to past questions or the current state of the database.

Backward Chaining System

In backward chaining, the system commences its search from the goal state, proceeding backwards through the rules, determining what conditions must be satisfied in order to validate the solution. Only questions relevant to the determination of the truth or falsity of the conditions concerned will be asked.

USER INPUT: Is the subbase suitable for slab placement?

SYSTEM (RULE 43): The subbase is suitable for slab placement, if compaction is $\geq 95\%$.

SYSTEM (RULE 1): Compaction is checked if the elevation is equal to the specified elevation.

SYSTEM RESPONSE: What is the compacted elevation, in feet?

USER INPUT: 1206

SYSTEM RESPONSE: What is the compacted density (%) ?

USER INPUT: 95

SYSTEM RESPONSE: Since the compacted elevation matched the specified elevation and the compacted density exceeded 95%, the subbase is ready for slab placement.

An important thing to note is the reversal of the rule

structure in backward chaining. IF-THEN rules are actually utilized as THEN, IF rules.

An inference mechanism must contain a consistency enforcer. The consistency enforcer ensures that rules added to update the rule base are consistent with one another. One can see the potential difficulty in having two rules with the same antecedent and opposing consequents.

Programming Skills

An underlying skill of the knowledge engineer which has not yet been addressed is that of programming. The engineer may not have to write the code himself, but must be intimately familiar with the language to be used and its strengths and weaknesses. The languages of expert systems are often as unique as the problems of application. It is not uncommon for a system designer to modify a language to fit his particular needs and then to build his own compiler. The languages which are currently best suited for expert systems are PROLOG (PROgramming in LOGic) (11) and LISP (LISt Programming) (67). PROLOG is especially suitable due to its built-in backtracking capabilities and recursive drive. The language is made for goal or rule driven systems. Languages such as PASCAL and C have also been used successfully and due to their widespread familiarity, are preferred by many programmers. Though they may be more common to programmers and may have greater numerical manipulation capabilities, the writer feels that their database management capabilities

and inferencing potential are far inferior to LISP and PROLOG.

Learning

One of the features of an expert system which requires special consideration is the ability to deal with new knowledge. For a system to be considered expert, it must be able to recognize when it is presented with data which it does not already contain, and it must be able to place that data in an appropriate place. An intelligent system must also be able to accept updated or new rules. Learning may also include a dynamic database which stores the inferences made during a given run and recognizes patterns in these inferences in order to write its own rules. As one may imagine, learning is the most difficult feature to incorporate into an expert system.

Expert System Shells

It is well known that the people who design and build expert systems should be masters of a variety of skills that take years to develop. The conceptual and technical difficulty of expert systems originally kept their development in the hands of a few experienced companies and research centers around the world. As public awareness of expert systems grew, however, people wanted a way to build such systems to solve smaller problems without acquiring a

knowledge engineer and investing the time and money needed to develop a mainframe system. Industrial researchers wanted to spend 90% of their resources on researching the problems at hand and 10% on the computer skills needed to implement a solution.

This demand led to the development of expert system "shells". An expert system shell is a fully developed expert system which has had its knowledge base removed. It contains a variety of user-friendly modifications to assist with the installation of a new knowledge base. Most shells are built for use on personal computers. A person who is using a shell to create a system need not worry about such things as the interpreter or the ordering mechanism because the shell contains a working inference engine. This frees the designer to concentrate on the gathering and representation of knowledge. Loading the rules onto the shell is then fairly straight forward.

It may appear at this point that shells are "too good to be true", but they certainly do have their shortcomings. Shells are built for use on personal computers, thus their biggest drawback is storage capacity. Although shells exist which utilize 128K RAM, most require 640K RAM, thus stretching the capacity of PC's. Although the number of rules which can be included is not severely restricted by such memory constraints, the amount of data stored in tabular format is restricted. The size of the problem which can be solved is constrained by the size of the computer system. A

shell may be used to build a system which assists the assembly of a diesel engine for a truck, but a system to help assemble the entire truck would require too much memory.

How does one know if his problem is of shell proportions? A convenient test is the "phone call" test (2). If the problem can be described to a novice over the telephone with no visual aids in 15 minutes or less, the problem should fit nicely on a shell. This works surprisingly well. A description of greater length generally indicates more rules than the PC can handle. A minicomputer or a mainframe are then needed.

Once the problem at hand has been labeled shell compatible, one must decide which shell to use. This task is not overwhelming because there are only 10-15 shells on the market today and the price range, \$50 to \$15,000, quickly helps narrow the choices. An in-depth comparison of the various shells and their capabilities has not yet been published so the ability to select an appropriate one is somewhat cognitive. It has been suggested that an expert system to assist individuals in the selection of the proper expert system shell is a problem worthy of further study. When selecting a shell, however, there are several considerations that must be made.

1. The system designer should be aware of how many rules he will generate and the capacity of the shell under consideration. Large problems do not always require many

rules and a large rule capacity does not necessarily indicate a powerful shell.

2. The shell must be compatible with the user's hardware and DOS package.

3. The shell should be adequate for the user's programming skills. Some shells are built for non-programmers while others require extensive computer programming experience.

4. A shell that tolerates certainty factors is usually desired unless it is known that system responses will only be "yes" or "no".

5. Forward or backward chaining is usually dictated by the problem. A system that provides both gives the designer greater flexibility.

6. The user should try to find someone who has the shell he is considering and experiment with it. Many of the shells are personally owned by people who do expert system research. Some manufacturers even supply demonstration disks for a minimal fee.

Appendix II, taken directly from PC World magazine (25), provides valuable information about the top shells on the

market. This information should be beneficial to anyone looking for a starting point.

Summary

It is realized that the scope of this chapter has been far too broad to provide an in-depth understanding of expert system construction. The fundamental concepts and key words have been provided, and hopefully the basic process of development has been conveyed. The following chapters will describe the development of a prototype system in detail and should shed light on the concepts presented thus far.

CHAPTER 3

AN EXPERT SYSTEM FOR TRENCH SAFETY: THE PROBLEM

The Need For A Proper Analysis of Soil Properties

The ultimate goal of a trench safety analysis is the protection of the workmen in the trench. This generally involves the use of a structure built either to protect the worker from collapsing walls or to prevent the walls from collapsing. The adequacy of any structure built to prevent trench walls from collapsing hinges upon an accurate determination of the lateral soil pressure in the wall. The determination of lateral soil pressure is generally made following a series of laboratory tests.

Traditional Approaches to Soil Analysis

Soil analysis in engineering has traditionally concentrated on classifying soils according to grain size distribution, plasticity, and organic content. These properties are obtained from an analysis of disturbed soil samples and are often augmented with test results taken from undisturbed, in-situ soil. Among the methods most commonly used are the triangular soil classification chart shown in Figure 3.1, developed by the U.S. Department of Agriculture, the AASHTO classification system, shown in Figure 3.2 (derived from a 1920's system utilized by the U.S. Bureau of Public Roads), and the Unified Soil Classification System

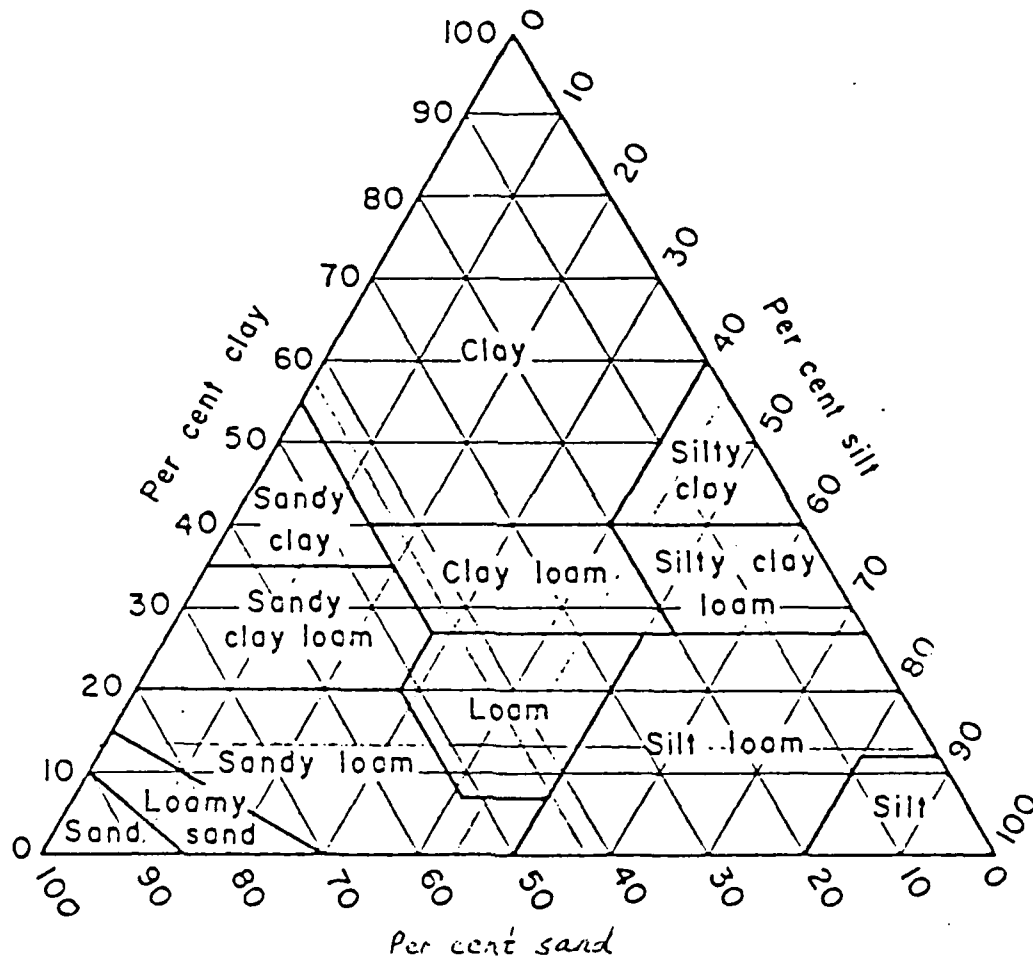

Figure 3.1 Triangular Soil Classification Chart (18, p. 33)

AASHTO Classification of Soils and Soil-Aggregate Mixtures

General Classification	Granular Materials (35% or less passing 0.075 mm)							Silt-Clay Materials (More than 35% passing 0.075 mm)			
	A 1		A 3	A 2			A 4	A 5	A 6	A 7	
Group Classification	A 1a	A 1b		A 2.4	A 2.5	A 2.6	A 2.7				
Sieve Analysis, Percent Passing 2.00 mm (No. 10) 0.425 mm (No. 40) 0.075 mm (No. 200)	50 max 30 max 15 max	50 max 25 max	51 min 10 max	35 max	35 max	35 max	35 max	36 min	36 min	36 min	
Characteristics of Fraction Passing 0.425 mm (No. 40) Liquid limit Plasticity index				40 max 10 max	41 min 10 max	40 max 11 min	41 min 11 min	40 max 10 max	41 min 10 max	40 max 11 min 41 min 11 min ^a	
Usual Types of Significant Constituent Materials	Stone Fragments Gravel and Sand		N.P.	Silty or Clayey Gravel Sand			Silty Soils		Clayey Soils		
General Rating as Subgrade	Excellent to Good							Fair to Poor			

^aPlasticity index of A 7 5 subgroup is equal to or less than LL minus 30.

Plasticity index of A 7 6 subgroup is greater than LL minus 30.

Figure 3.2 AASHTO Classification System
(18, p. 35)

MAJOR DIVISIONS	GROUP SYMBOLS	TYPICAL NAMES	CLASSIFICATION CRITERIA
COARSE GRAINED SOILS More than 50% retained on 0.075 mm (No. 200) sieve	GRAVELS 50% or more of coarse fraction retained on 4.75 mm (No. 4) sieve	CLEAN GRAVELS	GW Well graded gravels and gravel sand mixtures, little or no fines
		GRAVELS WITH FINES	GP Poorly graded gravels and gravel sand mixtures, little or no fines
		GRAVELS	GM Silty gravels, gravel sand mixtures
		GRAVELS	GC Clayey gravels, gravel sand mixtures
	SANDS More than 50% of coarse fraction (No. 4) sieve passes 4.75 mm (No. 4) sieve	CLEAN SANDS	SW Well graded sands and gravelly sands, little or no fines
		SANDS WITH FINES	SP Poorly graded sands and gravelly sands, little or no fines
		SANDS	SM Silty sands, sand silt mixtures
		SANDS	SC Clayey sands, sand clay mixtures
FINE GRAINED SOILS 50% or more passing 0.075 mm (No. 200) sieve	SILTS AND CLAYS Liquid limit 50% or less	ML Inorganic silts, very fine sands, rock flour, silty or clayey fine sands	$C_u = D_{60}/D_{10}$ Greater than 4 $C_c = \frac{D_{30}^2 - D_{10}^2}{D_{10}}$ Between 1 and 3 Not meeting both criteria for GW Atterberg limits plot below "A" line in hatched area are borderline classifications and plasticity indices greater than 7 symbols $C_u = D_{60}/D_{10}$ Greater than 6 $C_c = \frac{D_{30}^2 - D_{10}^2}{D_{10}}$ Between 1 and 3 Not meeting both criteria for SW Atterberg limits plot below "A" line in hatched area are borderline classifications and plasticity indices greater than 7 symbols
		CL Inorganic clays of low to medium plasticity, gravelly clays, sandy clays, silty clays, lean clays	
		OL Organic silts and organic silty clays of low plasticity	
		MH Inorganic silts, micaceous or diatomaceous fine sands or silts, elastic silts	
	SILTS AND CLAYS Liquid limit greater than 50%	CH Inorganic clays of high plasticity, fat clays	
		OH Organic clays of medium to high plasticity	
		PT Peat, muck and other highly organic soils	

Visual-Manual Identification, See ASTM Designation D 2488.

Figure 3.3 Unified Soil Classification System (18, p. 37)

shown in Figure 3.3. The triangular method classifies soils solely on the results of grain size determination. The AASHTO system extends the classification system using the results of liquid limit and plasticity index determinations. Soils containing fines are then subdivided by their Group Index which is calculated using the following equation:

$$\text{Group Index} = (F-35)[0.2 + 0.005(LL-40)] + 0.01(F-15)(PI-10)$$

where F = percent passing the #200 sieve, expressed as a whole number

LL = liquid limit

PI = plasticity index

The Unified Soil Classification System takes a slightly different approach. Soils are initially divided into three groups: coarse grained, fine grained, and highly organic. Coarse grained soils are divided into gravels and sands based upon their gradation. Fine grained soils are divided using their liquid limit and plasticity index into silts, clays, and organic silts and clays. The value of such a classification will be illustrated below.

Determination of Lateral Earth Pressure

Lateral earth pressure of in-situ soil is a function of the vertical earth pressure times a constant as illustrated by Figure 3.4. This constant is dependent upon the lateral

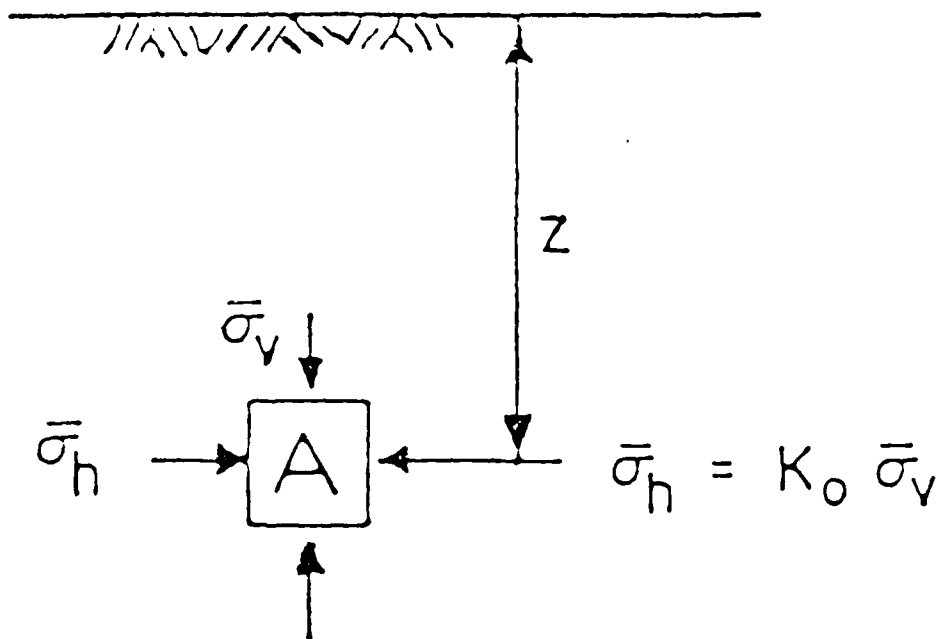

Figure 3.4 Lateral Earth Pressure as a Function of Vertical Earth Pressure (18, p. 197)

yielding condition of the soil mass. Soils which have not been subjected to lateral yielding are considered to be in the at-rest state. The constant for the at-rest state, K_0 , is a complex function of the overconsolidation ratio, ϕ , and the plasticity index. Figure 3.5 shows an example of the variation of K_0 with the overconsolidation ratio for certain soils. Soils subject to lateral compression are in the passive state. The constant for the passive state, K_p , is more difficult to determine. Because the use of retaining structures in trenches involves soils subjected to lateral yielding, but not lateral compression, the derivation of K_p will not be discussed below.

The situation of interest is known as the active state and it occurs whenever a soil deposit yields in such a fashion so as to cause horizontal stretching of the soil. The active earth pressure coefficient, K_a , is obtained from the following equation:

$$K_a = \tan^2\left(45 - \frac{\phi}{2}\right)$$

where ϕ = the effective angle of intergranular friction

The derivation of this equation requires the shear strength parameters of a soil sample.

The shear strength of a soil sample may be determined using one of three tests: the Consolidated-Drained (CD) test, the Consolidated-Undrained (CU) test, or the Unconsolidated-Undrained (UU) test. For illustrative purposes, the CD direct shear test will be discussed.

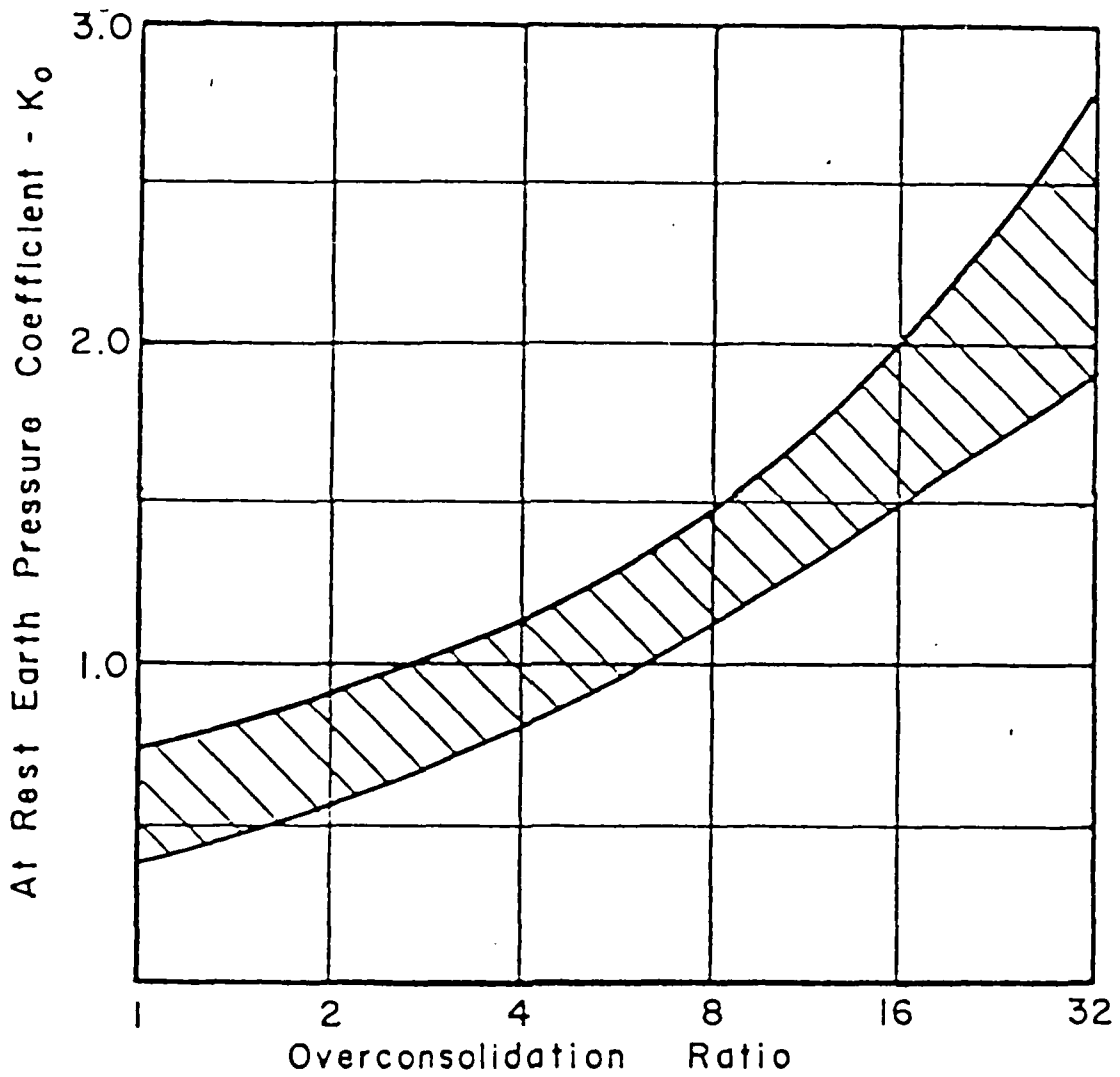

Figure 3.5 Variation of K_0 with OCR for Some Soils
(18, p. 197)

Consolidated-Drained (CD) Test

The soil sample in the laboratory, after having been consolidated under a normal load, N , and allowed to drain, is sheared by a horizontal load, T . This is shown in Figure 3.6. A plot is made of the shear stress, $\bar{\tau}$, required to cause shear failure at various levels of normal stress, $\bar{\sigma}$. Such a plot is shown in Figure 3.7. The data from this plot can be used to draw the Mohr's circle and the Mohr-Coulomb failure envelope for the soil. A sample plot is presented in Figure 3.8. By drawing a circle tangent to the failure envelope for a given pair of $\bar{\sigma}$, $\bar{\tau}$ conditions, the principal stresses of the sample at failure, $\bar{\sigma}_1$ and $\bar{\sigma}_3$, can be determined. K_a is derived utilizing these stresses as shown in Figure 3.9. Substituting K_a into the equation for lateral earth pressure yields:

$$\bar{\sigma}_a = \left[\tan^2 \left(45 - \frac{\bar{\phi}}{2} \right) \right] \bar{\sigma}_v$$

This equation is valid for all cohesionless soils. For a cohesive soil, the relationship includes a cohesion term:

$$\bar{\sigma}_a = K_a \bar{\sigma}_v - 2\bar{C}\sqrt{K_a}$$

The value of an accurate soil classification system can now be seen. As long as C and ϕ can be determined, soil classification is relatively unimportant. When these values are unavailable, however, a soil classification by one of the methods previously mentioned is critical to the analysis.

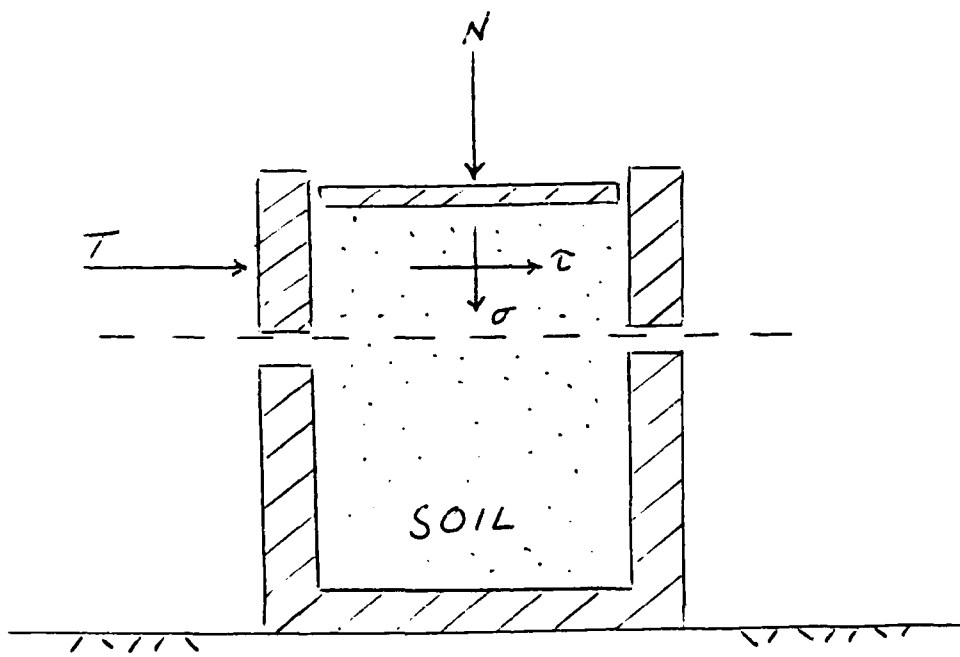
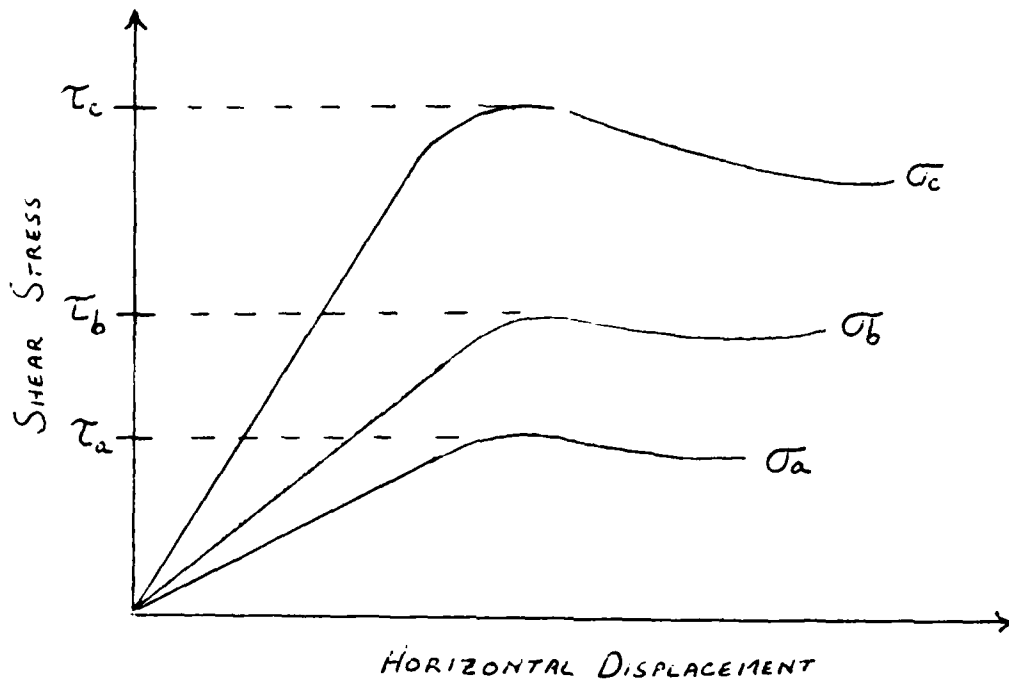

Figure 3.6 (CD) Direct Shear Test



NORMAL LOAD N	NORMAL STRESS $\sigma = N/A$	SHEAR LOAD T_{max}	SHEAR STRENGTH $\tau_{max} = T_{max}/A$
N_a	σ_a	T_a	τ_a
N_b	σ_b	T_b	τ_b
N_c	σ_c	T_c	τ_c

Figure 3.7 Results of Direct Shear Test

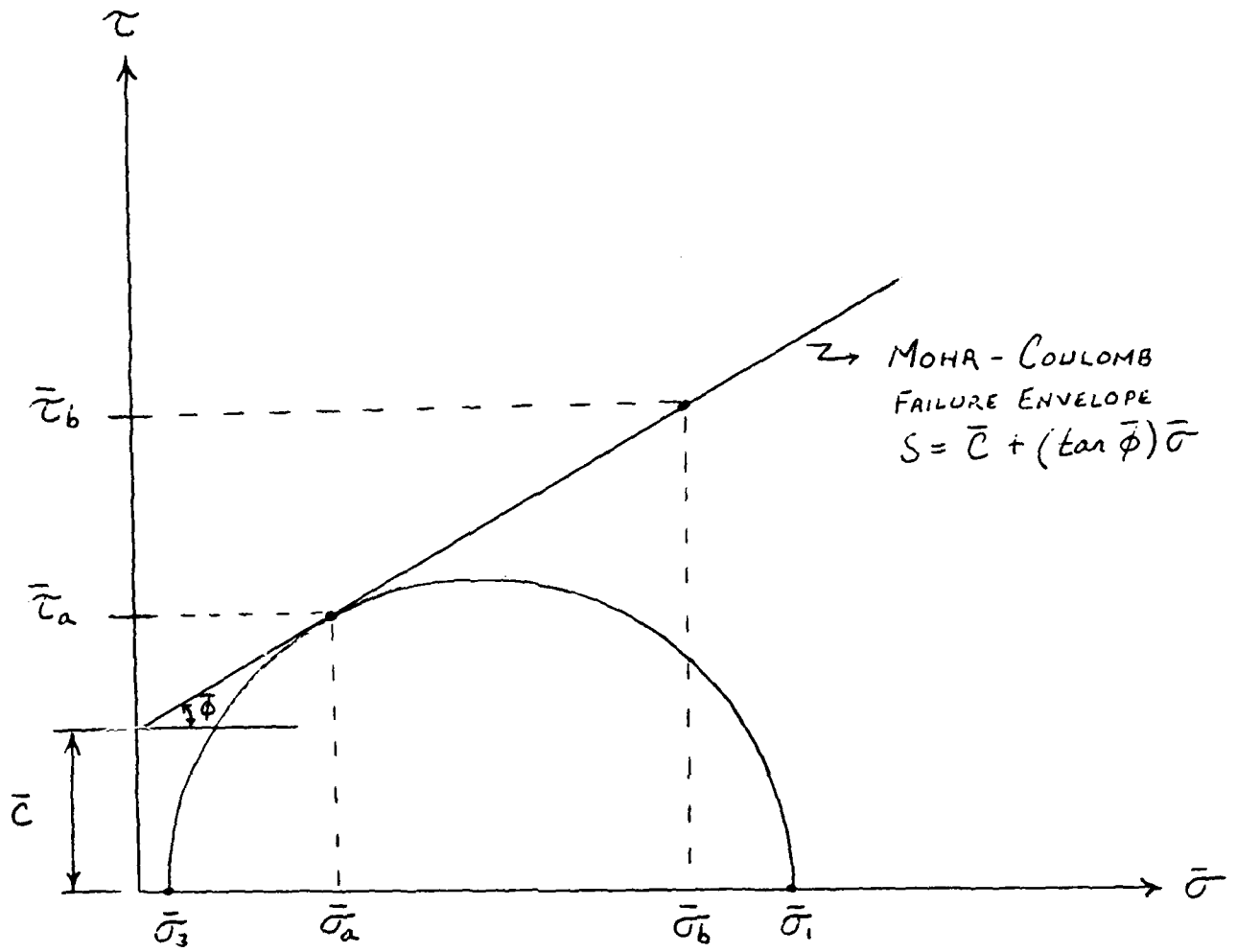
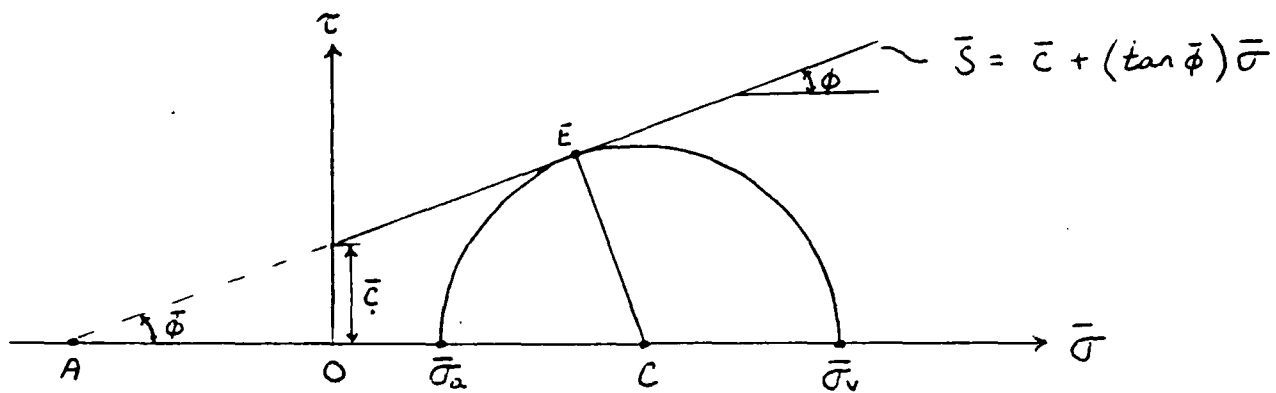

Figure 3.8 Mohr's Circle Plot of Shear Test



$$\overline{EC} = \frac{\overline{\sigma}_v - \overline{\sigma}_a}{2}$$

$$\overline{AC} = \frac{\overline{c}}{\tan \bar{\phi}} + \left(\frac{\overline{\sigma}_a + \overline{\sigma}_v}{2} \right)$$

$$\overline{EC} = \overline{AC} \sin \bar{\phi}$$

$$\therefore \frac{\overline{\sigma}_v - \overline{\sigma}_a}{2} = \left(\frac{\overline{c}}{\tan \bar{\phi}} + \left(\frac{\overline{\sigma}_a + \overline{\sigma}_v}{2} \right) \right) \sin \bar{\phi} = \overline{c} \cos \bar{\phi} + \left(\frac{\overline{\sigma}_a + \overline{\sigma}_v}{2} \right) \sin \bar{\phi}$$

$$\overline{\sigma}_v - \overline{\sigma}_a = 2\overline{c} \sqrt{1 - \sin^2 \bar{\phi}} + (\overline{\sigma}_a + \overline{\sigma}_v) \sin \bar{\phi}$$

$$\overline{\sigma}_v - \overline{\sigma}_a - \overline{\sigma}_a \sin \bar{\phi} - \overline{\sigma}_v \sin \bar{\phi} = 2\overline{c} \sqrt{(1 + \sin \bar{\phi})(1 - \sin \bar{\phi})}$$

$$\overline{\sigma}_v (1 - \sin \bar{\phi}) - \overline{\sigma}_a (1 + \sin \bar{\phi}) = 2\overline{c} \sqrt{(1 + \sin \bar{\phi})(1 - \sin \bar{\phi})}$$

$$\overline{\sigma}_v \left(\frac{1 - \sin \bar{\phi}}{1 + \sin \bar{\phi}} \right) - \overline{\sigma}_a = 2\overline{c} \sqrt{\frac{(1 - \sin \bar{\phi})(1 - \sin \bar{\phi})}{(1 + \sin \bar{\phi})(1 + \sin \bar{\phi})}}$$

$$\overline{\sigma}_v \left(\tan^2 \left[45 - \frac{\bar{\phi}}{2} \right] \right) - \overline{\sigma}_a = 2\overline{c} \sqrt{\tan^2 \left[45 - \frac{\bar{\phi}}{2} \right]}$$

$$\therefore \overline{\sigma}_a = \overline{\sigma}_v (K_a) - 2\overline{c} \sqrt{K_a}$$

$$\text{WHERE } K_a = \tan^2 \left[45 - \frac{\bar{\phi}}{2} \right]$$

Figure 3.9 Derivation of K_a
(18, p. 201)

Determination of the Lateral Force on a Retaining Wall

Once the active lateral stress has been determined, the resultant force against the wall due to a soil mass behind the retaining wall and the point of application of the resultant force can be determined using Rankine theory. Figure 3.10 illustrates a variety of potential situations and the resultant force that occurs due to each situation.

Field Methods of Soils Analysis

The engineer faced with the determination of lateral soil pressures behind a rigid retaining structure thus has well founded methods at his disposal. These methods require an accurate determination of ϕ , the internal angle of friction, and c , the cohesion of the soil. These values are found using the Mohr-Coulomb failure envelope plotted after an analysis of the shear strength. It is an unfortunate economic reality, however, that a contractor involved in short term, light commercial trench operations can seldom afford the time or the cost of a laboratory analysis to provide these values. Peck, Hansen, and Thornburn (44) recognized the need to estimate lateral soil pressure and, as a result, developed the chart presented in Figure 3.11. This chart is based partly on theory and partly on studies of the performance of satisfactory and unsatisfactory retaining walls supporting backfill material. If the conditions on the construction project allow such a chart to be used, then soil classification can be reduced to a visual inspection and

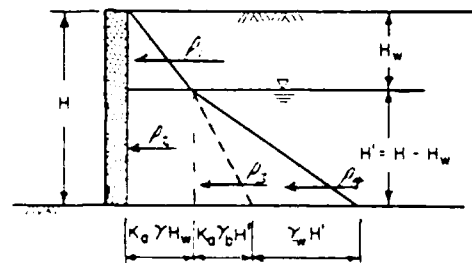
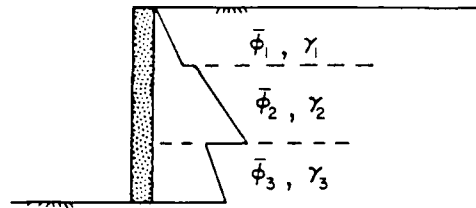
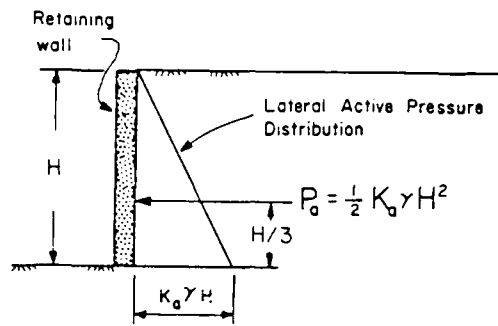

$$P_1 = \frac{1}{2} \gamma H_1^2 K_a$$

$$P_2 = \gamma H_1 H_2 K_a$$

$$P_3 = \frac{1}{2} \gamma H_2^2 K_a$$

$$P_w = \frac{1}{2} \gamma_w H_w^2$$

$$P_A = P_1 + P_2 + P_3 + P_w$$

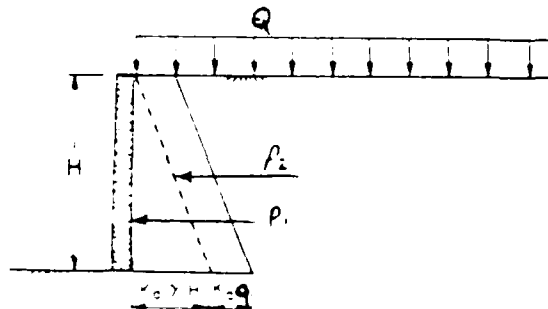

$$P_1 = \frac{1}{2} \gamma H^2 K_a$$

$$P_2 = Q H K_a$$

$$P_A = P_1 + P_2$$

Figure 3.10 Variations in Lateral Earth Pressure
(18, pp. 204-206)

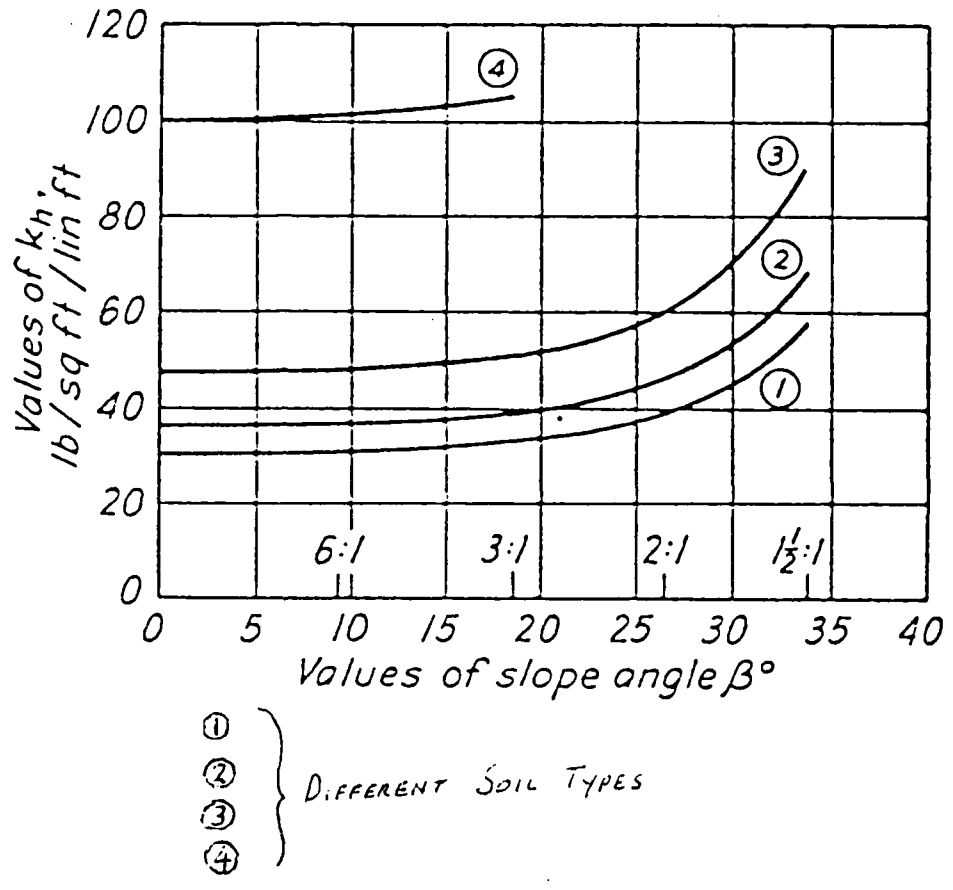
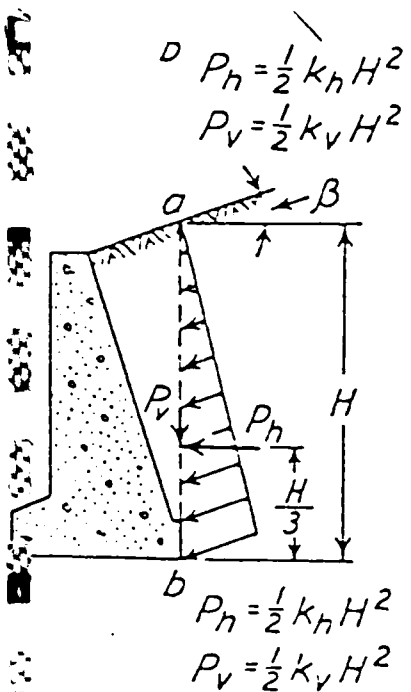

Figure 3.11 Estimating Lateral Soil Pressure (44, p. 286)

categorization into one of four classes. The need for specific values of ϕ and C has been eliminated.

Felix Y. Yokel (58) headed a study for the National Bureau of Standards in 1982 which looked deeply into the problems of safe trench shoring systems in order to provide updated recommendations for OSHA 1926.6, Subpart P. A major concern of the study was the classification of soils into one of four types in order to allow the decision maker to retrieve required timber shoring data from OSHA Table P-2 shown in Figure 3.12. Yokel decided to develop a classification system which meshed with the work done by Peck and others, thereby providing a procedural method of classification and an associated lateral soil pressure determination. The method developed for classifying the soil is called the Matrix Classification System and is shown in Figure 3.13. The soil is classified as Type I, II, III, or IV based upon site conditions such as the presence of water and fissures as well as the properties of the soil.

As a result, the soil is placed in one of four categories: stiff cohesive, medium cohesive, granular, and soft. Yokel then assigned a value to each soil type known as the lateral weight effect, W_e , which is displayed in Figure 3.14. These values are taken from Peck's chart utilizing an intermediate, constant slope angle and setting $W_e = (0.6)Kh$. Yokel also recommended using the rectangular pressure diagram shown in Figure 3.15 as the basis of force calculations. This approximation is necessary because of the effects of

TABLE P-3

TRENCH SHORING—MINIMUM REQUIREMENTS

Depth of trench	Kind or condition of earth	Size and spacing of members													
		Uprights				Struts				Cross braces ¹				Maximum spacing	
		Inches	Feet	Inches	Feet	Inches	Inches	Inches	Inches	3 to 8 feet	8 to 9 feet	9 to 12 feet	12 to 15 feet	Vertical	Horizontal
		Minimum Maximum dimension spacing													
6 to 10	Hard, compact	3 x 4 or 2 x 6	6	2 x 6	4 x 4	4 x 6	6 x 6	6 x 8	6
	Likely to crack	3 x 4 or 2 x 6	8	4 x 6	4	2 x 6	4 x 6	4 x 6	4 x 6	2 x 6	4 x 6	4 x 6	6 x 6	6 x 8	6
	Soft, sandy, or filled	3 x 4 or 2 x 6	Close sheeting	4 x 6	4	4 x 4	4 x 6	4 x 6	4 x 6	4 x 6	4 x 6	6 x 8	8 x 8	4	6
	Hydrostatic pressure	3 x 4 or 2 x 6	Close sheeting	8 x 8	4	4 x 4	4 x 6	4 x 6	4 x 6	4 x 6	4 x 6	6 x 8	8 x 8	6	6
10 to 14	Hard	3 x 4 or 2 x 6	4	4 x 6	4	4 x 4	4 x 6	4 x 6	4 x 6	4 x 6	4 x 6	6 x 8	8 x 8	6	6
	Likely to crack	3 x 4 or 2 x 6	2	4 x 6	4	4 x 4	4 x 6	4 x 6	4 x 6	4 x 6	4 x 6	6 x 8	8 x 8	6	6
	Soft, sandy, or filled	3 x 4 or 2 x 6	Close sheeting	4 x 6	4	4 x 6	4 x 6	4 x 6	4 x 6	4 x 6	4 x 6	6 x 8	8 x 10	6	6
	Hydrostatic pressure	3 x 6	sheeting	8 x 10	4	4 x 6	4 x 6	4 x 6	4 x 6	4 x 6	4 x 6	6 x 8	8 x 10	6	6
15 to 20	All kinds or conditions	3 x 6	sheeting	4 x 12	4	4 x 12	4 x 12	4 x 12	4 x 12	4 x 12	4 x 12	6 x 8	8 x 10	6	6
Over 20	All kinds or conditions	3 x 6	sheeting	6 x 8	4	4 x 12	4 x 12	4 x 12	4 x 12	4 x 12	4 x 12	6 x 10	10 x 10	6	6

¹ Trench jacks may be used in lieu of, or in combination with, cross braces. Shoring is not required in solid rock, hard shale, or hard clay. Where desirable, steel sheet piling and bracing of equal strength may be substituted for wood.

Figure 3.12 OSHA 1926 Table P-2 (61, p. 198)

Table 5.3 Soil Classes in Matrix Classification System

Soil \ Site Condition	Water in Trench			
	No		Yes	
	Fissures		Fissures	
	No	Yes	No	Yes
Stiff Cohesive ^{a/}	I	II	III	
Medium Cohesive ^{a/}	II	III	III	IV
Granular ^{b/}	II		III	
Soft	IV		IV	

Notes:

1. Water in Trench is assumed whenever water drains into the trench from the soil forming the bank, or water is retained by tight sheeting, or there is a possibility that the trench may become fully or partially flooded before workers leave it, or may be entered by workers within 6 hours after more than half its depth was flooded and pumped out.
2. Vibrations: Soils subject to vibrations by heavy traffic, pile driving or similar effects shall always be assumed fissured.
3. Stiff Cohesive Soils^{a/} include stiff clays and cohesive or cemented sands and gravels (till, hardpan). Stiff clays included have an unconfined compressive strength (pocket penetrometer reading) $q_u = 1.5 \text{ tsf}^2/$ or larger.
4. Medium Cohesive Soils^{a/} have an unconfined compressive strength (pocket penetrometer reading) between 0.5 and $1.5 \text{ tsf}^2/$.
5. Granular Soils^{b/} are gravels, sands and silts that can stand on a slope steeper than 3 hor.: 1 vert. without spalling or slumping.
6. Fractured Rock shall be treated as granular soil. Intact rock is exempt from shoring and sloping requirements.
7. Soft Soils are cohesive soils ^{a/} with an unconfined compressive strength (pocket penetrometer reading) of $0.5 \text{ tsf}^2/$ or less and granular soils that can not stand on a slope of 3 hor.: 1 vert. without slumping (muck).
8. Layered Systems (two or more distinctly different soil or rock types, micaceous seams in rock) which dip toward the trench wall with a slope of 4 hor.: 1 vert. or steeper are considered Class IV soils.
9. Disturbed Cohesive Soils (backfill) shall be treated as fissured medium cohesive or soft cohesive soil.
10. Spaced Shoring Systems (skeleton sheathing or skip shoring) are permitted in stiff and medium cohesive soil with maximum center to center spacing in accordance with Table 5.5.

^{a/} Cohesive Soils are clays (fine grained) or soils with a high clay content which have cohesive strength. They do not crumble, can be excavated with vertical sideslopes, are plastic (can be molded into various shapes and rolled into threads) when moist and are hard to break up when dry.

^{b/} Granular Soils have no cohesive strength. They normally can not be excavated with vertical sideslopes (some moist granular soils will exhibit apparent cohesion and temporarily stand on a vertical slope), they can not be molded when moist and crumble easily when dry.

^{2/} 1 tsf = 96 kPa

Figure 3.13 Matrix Classification System
(58, p. 85)

<u>SOIL</u>	<u>TYPE</u>	<u>LATERAL WEIGHT EFFECT</u>
		We in (lb./ft ³)

I	--	20
II	---	40
III	---	60
IV	---	80

Figure 3.14 Lateral Weight Effects
(58, p. 89)

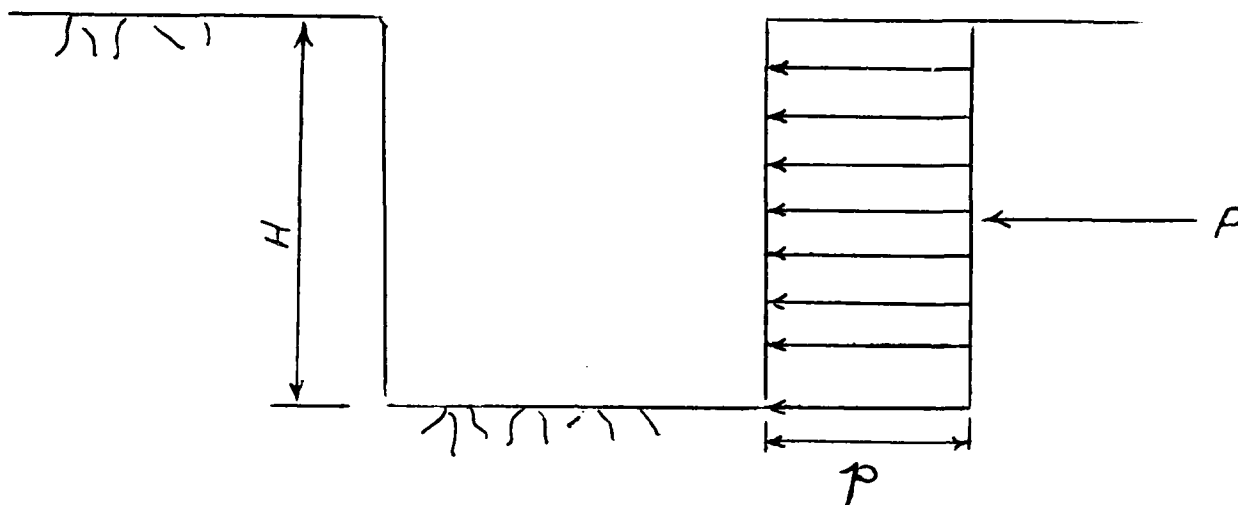

$$p = W_e (H + 2)$$

$$P = p \times H$$

H = Height of Supported Bank (ft.), 2ft. are added to allow for surcharge

p = Distributed Horizontal Earth Pressure (lb./ft²)

P = Resultant Horizontal Force per Unit Length (lb./ft.)

W_e = Lateral Weight Effect (lb./ft³)

Figure 3.15 Rectangular Pressure Diagram
(58, p. 35)

wall flexibility and variations in construction sequence. Less conservative shapes are precluded (56).

The heuristic classification system and determination of lateral soil pressures provide an obvious benefit to the contractor. Although the values obtained are perhaps overly conservative, the contractor need not concern himself with a lengthy laboratory analysis and may obtain enough information in a matter of minutes to assemble a timber shoring system or select a proper slope angle. A disadvantage which is not so obvious stems from the conservative nature of the approach. The disadvantage is discussed later in this chapter.

Methods of Trench Wall Stabilization

A contractor has many methods of trench wall stabilization at his disposal. Among the less common are stabilization by injection, electroosmosis, and freezing. Readers interested in any of these three methods are referred to General Excavation Methods, by A. Brinton Carson (7). Slightly more common is the use of sheet piles, driven before excavation, and soldier beams, driven as individual piles and spaced to allow for the insertion of timber planks as sheeting. It is the writer's opinion that these methods are too time consuming and expensive for use in short term trench operations. Most contractors employ trench boxes, sheeting with trench jacks (hydraulic or manual), timber frame shoring, or bank sloping.

Bank Sloping

A contractor opting to slope the trench banks may utilize any one of three allowable configurations shown in Figure 3.16 to comply with federal regulations (59).

Timber Frame Shoring

A contractor choosing to construct a timber frame shoring system is guided by OSHA 1926, Subpart P, Table P-2 (61). This table was presented as Figure 3.12. As Figure 3.12 indicates, sheeting, wale, and strut requirements are dictated by the depth of the trench and a visual classification of the soil. Yokel (56) has provided a replacement for these classifications with soil Types I, II, III, IV. Therefore, a procedural method of shoring member selection is available. A common arrangement of the members required using Table P-2 is conceptualized in Figure 3.17.

Inconsistencies With Current Tabular Methods

Identification of Inconsistencies

Initial efforts by the writer to develop an expert system prototype to enhance the selection of timber frame shoring attempted to apply the matrix classification system, obtain a lateral earth pressure and a required shoring design, and then select a suitable type of lumber by applying

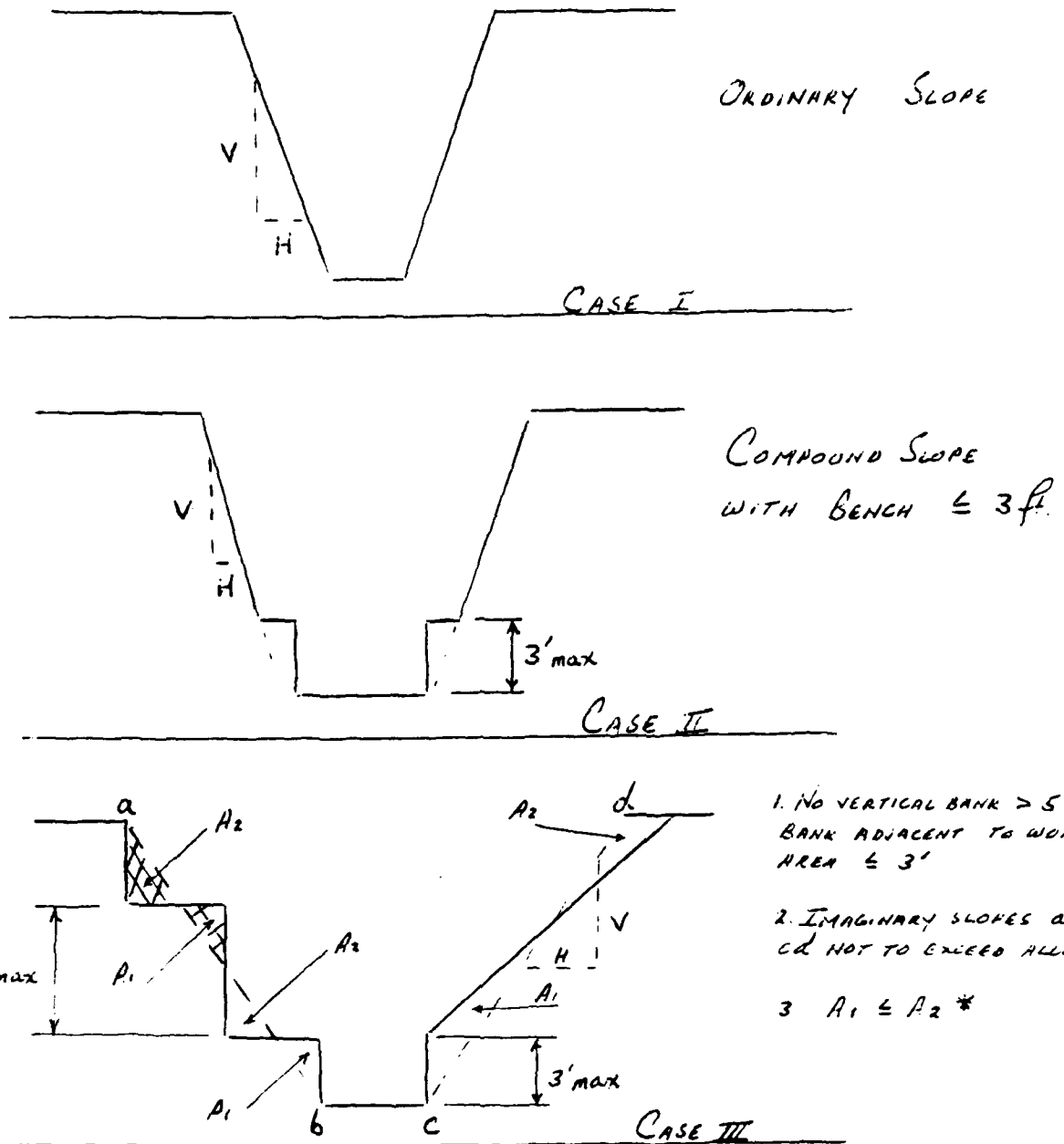

* NOTE: A_1 AND A_2 ARE THE AREAS OF THE INDICATED TRIANGLES

Figure 3.16 Allowable Sloping Configurations (59, p. 12)

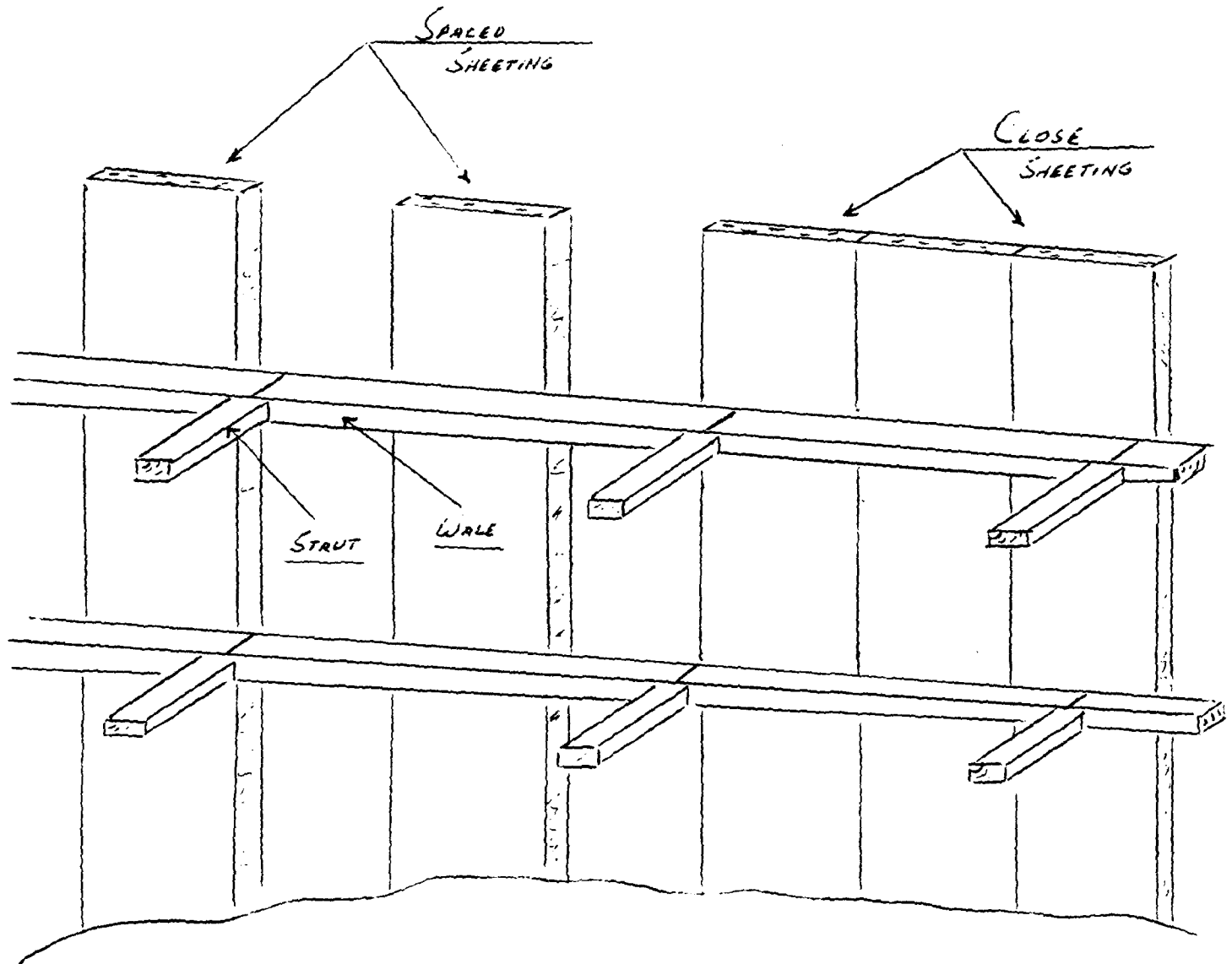

Figure 3.17 Typical Timber Shoring Design

well known equations of shear, compression, and elastic modulus to the wood structural members. Initial runs of the system revealed stresses that were so high that lumber with the required strength did not exist and thus no recommendations could be made. A thorough review of the work done by NBS led to personal correspondence with Dr. Yokel to determine if he had encountered similar difficulties. A copy of the letter and the calculations forwarded to him are enclosed in Appendix 3. The immediate question raised was that of functionality. According to the analysis, the timber shoring recommendations provided by Table P-2 should be failing frequently, yet that has not been the case. An ensuing phone conversation with Dr. Yokel revealed that an examination of the calculations used to develop Table P-2 would not be possible. He stated that he too had been unable to verify the table using a similar analysis. OSHA Table P-2 had evidently been empirically developed from a series of regional interviews with contractors in an effort to define "what works."

Dr. Yokel's study resulted in several proposed revisions to the table (58) and they were forwarded to OSHA for inclusion in a revised instruction in 1982. The revised instruction has as yet not been released.

Explanation of Inconsistencies

To answer the question of why the analysis performed in Appendix 3 and reviewed by Dr. Yokel could not substantiate

well tested designs, it is necessary to re-examine some of the assumptions made up to this point.

First and foremost is the conservative nature of the classification system and the method used to assign the lateral weight coefficients.

Second, although it would be difficult to justify another shape, the rectangular pressure diagram assumption is obviously conservative.

Third, the assumption that the shoring could be analyzed as a beam on rigid supports probably does not reflect the actual field conditions. It is a well known fact that timber deflects substantially under loads. This flexing relieves and reapporitions the pressures in the trench wall. An analysis of the shoring system as a beam on flexible supports might therefore provide a better understanding of the stresses involved. This analysis would be quite problem dependent for it would have to consider many factors about the moisture content and properties of the specific wood used as well as the compressive properties of the soil so that spring constants could be obtained. Although lengthy, the analysis might provide a better method of tabularizing timber shoring designs. It should be noted that such an analysis was not conducted as a part of this research because the focus was not the in-depth study of timber frame earth retaining structures, it was rather an application of expert system technology to existing expertise. Such a thrust, however, can be suggested as an area for future research.

Affect On Expert System Development

Because of the writer's inability to accurately define a set of equations which would enable the calculation of sizes of timber shoring members, this planned capability of the prototype expert system was deleted. Instead, it was decided that the system would utilize the member sizes suggested by OSHA, Table P-2 which makes no recommendation concerning the most suitable type of lumber. This table remains the legal standard and although it is not well supported by engineering calculations, it has worked satisfactorily in the past.

Elements of Trench Safety Not Related To Shoring

Miscellaneous Safety Features

Although bank stabilization is a primary element of trench safety, there are other factors to be considered in an overall safety analysis. During the project planning and the construction stages, a contractor must be fully aware of safety equipment and construction practices that may affect the safety of his jobsite. The location of utility lines and the development of emergency procedures to be followed when a line is unexpectedly broken merit concern. The improper removal of surface encumbrances, such as stumps and boulders can present hazardous conditions. Mobile equipment which may be operating at or near the edge of the trench mandates particular caution. The proper placement of walkways.

bridges, ramps, ladders, and barriers are often overlooked on small jobs. Hazardous dusts, gases, fumes, and oxygen deficiencies may require the use of special equipment such as explosimeters and respiratory masks. It has been the writer's personnel experience that standard personal protective equipment such as hardhats, goggles, and gloves are perhaps the easiest items to obtain, yet seem to be the items most often neglected. A thorough, periodic safety inspection should account for all of these items.

Construction Site Practices

In addition to the features of the trench operation which require particular attention, there are often adjacent operations on the site which may greatly influence trench stability. Flasting on the site changes the character of the soil and the pressures in the trench walls. Rapid dewatering may create quick conditions on the floor of the trench. The storage and retainage of spoil bank material excavated from and piled next to the trench may alter the stability of the trench wall. Such practices create falling object hazards if the material is positioned improperly. The safety inspection routine followed on the project to which these practices will definitely enhance or detract from the trench operations.

Summary

The safety of a workman in a trench is dependent upon a thorough investigation of all of these items discussed in this chapter. If standards are to be satisfied, soil analysis, bank stabilization, miscellaneous safety features, and proper construction practice must all be examined. The complexity of this analysis warrants special expertise. Chapter 4 proposes a unique application of a new technology to provide such expertise.

CHAPTER 4

SETYCHEE. AN EXPERT SYSTEM PROTOTYPE FOR TRENCH SAFETY ANALYSIS

Problem Definition

Chapter 3 presented the various components of the situation faced by a contractor who is trying to provide a safe trench environment for trench workers. The contractor must perform a soil analysis to determine the engineering properties of the soil. Time and expense lessen the likelihood of using laboratory techniques so they often rely on experience or systems such as the Matrix Classification System. The soils analysis data must then be combined with trench parameter data to determine proper sloping angles or to provide a tabular determination of an adequate shoring design. Optimally, the contractor should design shoring systems based on particular jobsite and material conditions. However, as was discussed in Chapter 3, this problem is not a simple one. In addition, individual design is discouraged because the provisions of OSHA 1926 Table P-2 provide sufficient, though over-designed, systems.

After a shoring system or slope angle has been selected, the contractor must carefully consider the site conditions and construction methods in order to determine if particular safety equipment or specialized safety procedures are

required. The contractor who performs these tasks in earnest greatly reduces the risk of accidents on his jobsite.

SFTYCHEF was designed to provide consultative, diagnostic assistance to the contractor in making the necessary decisions. It performs the soil analysis using the Matrix Classification System, gathers trench parameter data, site specific information, construction method information and then evaluates the overall operation as either being safe or unsafe. It also performs a table look-up and provides the contractor with an implementable shoring design and an acceptable slope angle. A list of safety notes is also furnished. These highlight the specific safety equipment the contractor must utilize and any specific safety procedures which must be followed. References to sources of more specific information are also provided. SFTYCHEF has a narrow set of suitable situations in which it can be used, however SFTYCHEF was specifically designed for:

1. Trench operations in which the trench is open for 24 hours or less.
2. Trenches whose depth does not exceed 20 feet.
3. Trenches which are not located near an adjacent, existing foundation.

4. Trenches which are not located in climates characterized by excessive amounts of rainfall.

SFTYCHEF helps the contractor identify the features of a safe operation. The contractor must then implement the recommended actions.

Knowledge Base

Knowledge Acquisition

The basis of the complete and verifiable knowledge included in any expert system hinges upon the dedication of an expert or experts to the system development. Expert dedication exceeds the scope of an interested faculty member or a quick learning student. Periodic interviews also seldom provide the needed interaction. Ideally, the expert should be the one with the problem which the system will solve. The expert's knowledge, perhaps verified by his status as a Professional Engineer and years of experience, provides the basis from which the knowledge engineer will develop the system. It is often true that the knowledge engineer becomes an expert in the domain as he constructs the system. This is a result of the continuous interaction with the expert. It is illogical to assume that true expertise can be extracted from a novice. In the words of G.L. Simons (51), "It is certainly possible for an incompetent to create an incompetent expert system."

It should be noted that the development of SFTYCHEF was not supported by a dedicated expert. This lack of expert interaction represents its major weakness at this stage of its development. The knowledge to construct the system was acquired via the writer's own course work, literature search, and personal experience. Attempts were made to utilize expertise from within OSHA, the U.S. Navy Civil Engineer Corps, and the U.S. Army Corps of Engineers, but to no avail. This was not particularly surprising since the work was an unsponsored research project. Often researchers have an inflated view of the importance of their work and expect instant support from others. Unfortunately, this view is seldom shared by outside agencies, unless great advantage is to be obtained through active participation.

The knowledge contained in SFTYCHEF is, however, not inaccurate because all knowledge was extracted from creditable sources. The completeness of the knowledge base is, however, suspect. J. McDermott (38), designer of R1, a system which configures VAX 11/780's for the Digital Electronics Corporation, constructed a knowledge base of approximately 200 rules on his own, using personal expertise and literature review. After a two month period of daily interaction with experts, the knowledge base tripled. SFTYCHEF would probably also benefit greatly from such a period of interaction.

Knowledge Representation

As information relevant to the problem was initially being acquired, much thought was given to the use of semantic nets, state-space, or logic representation schemes. It was quickly discovered that the overwhelming amount of information did not fit quickly or conveniently into such formats. Current literature does not provide any practical instructions on how to collect and represent the knowledge. Perhaps this report can alleviate a portion of the difficulties involved.

The procedure developed by the writer included a large chart which was placed on a wall. The chart was approximately 8 feet by 6 feet in size and was made of white posterboard. The top center of the posterboard was labeled with the system objective and below that, subgoals were placed on separate pieces of posterboard and connected with lines to the main objective. Figures 4.1 and 4.2 serve as a basic illustration. As knowledge was collected, it was listed quite randomly at first under the subgoal to which it pertained. As the boards began to fill up, it became easier to see patterns and relationships among the information. The use of separate boards for each subgoal was essential, because at some point, the boards could then be taken off the wall, reorganized and replaced by a new board. Each board eventually looked like either a decision tree, a listing of conditions, a listing of facts, or a combination of rules.

At this stage, the scope of the problem was refined

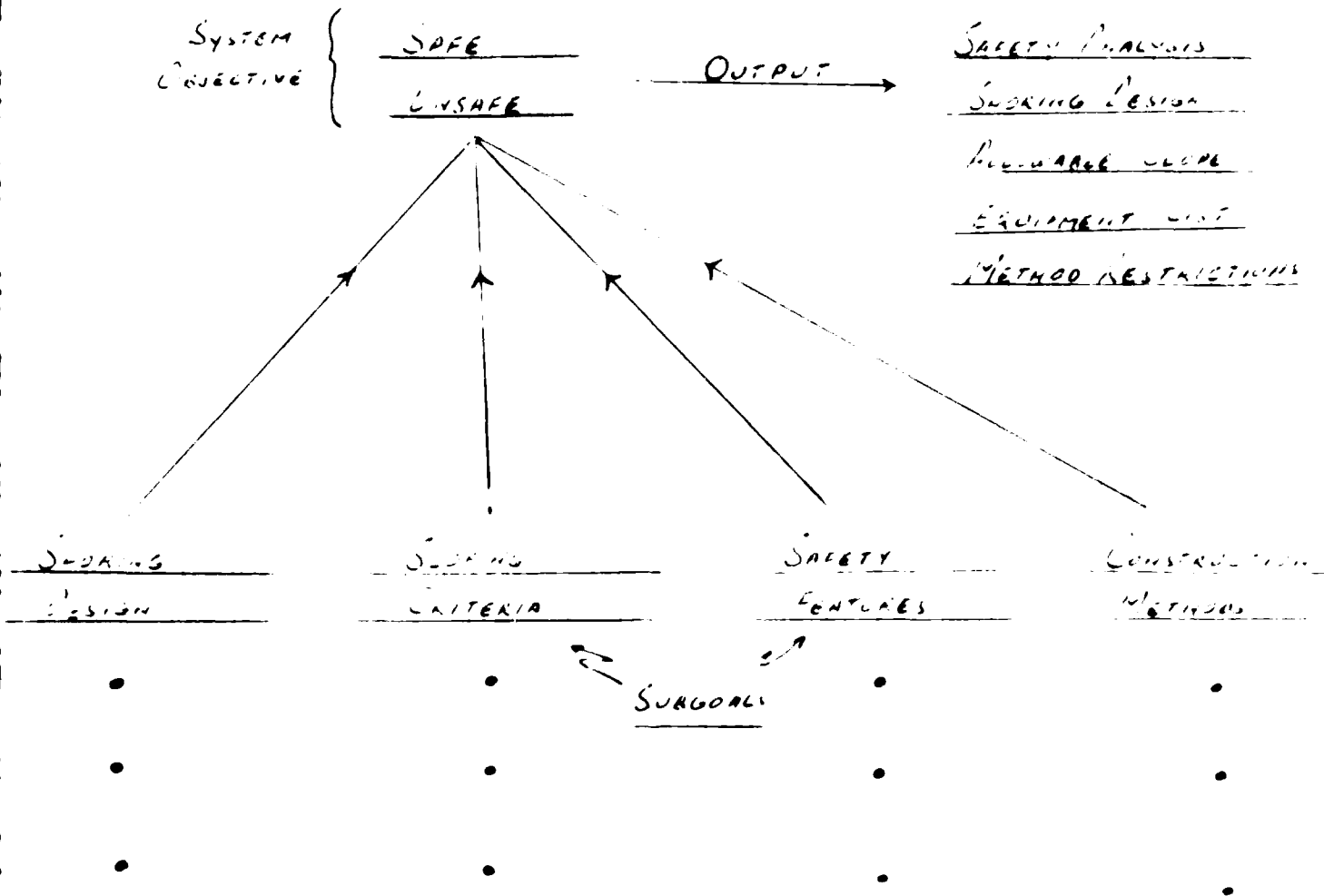

Figure 4.1 Wall Chart Schematic: Primary Subgoal Level

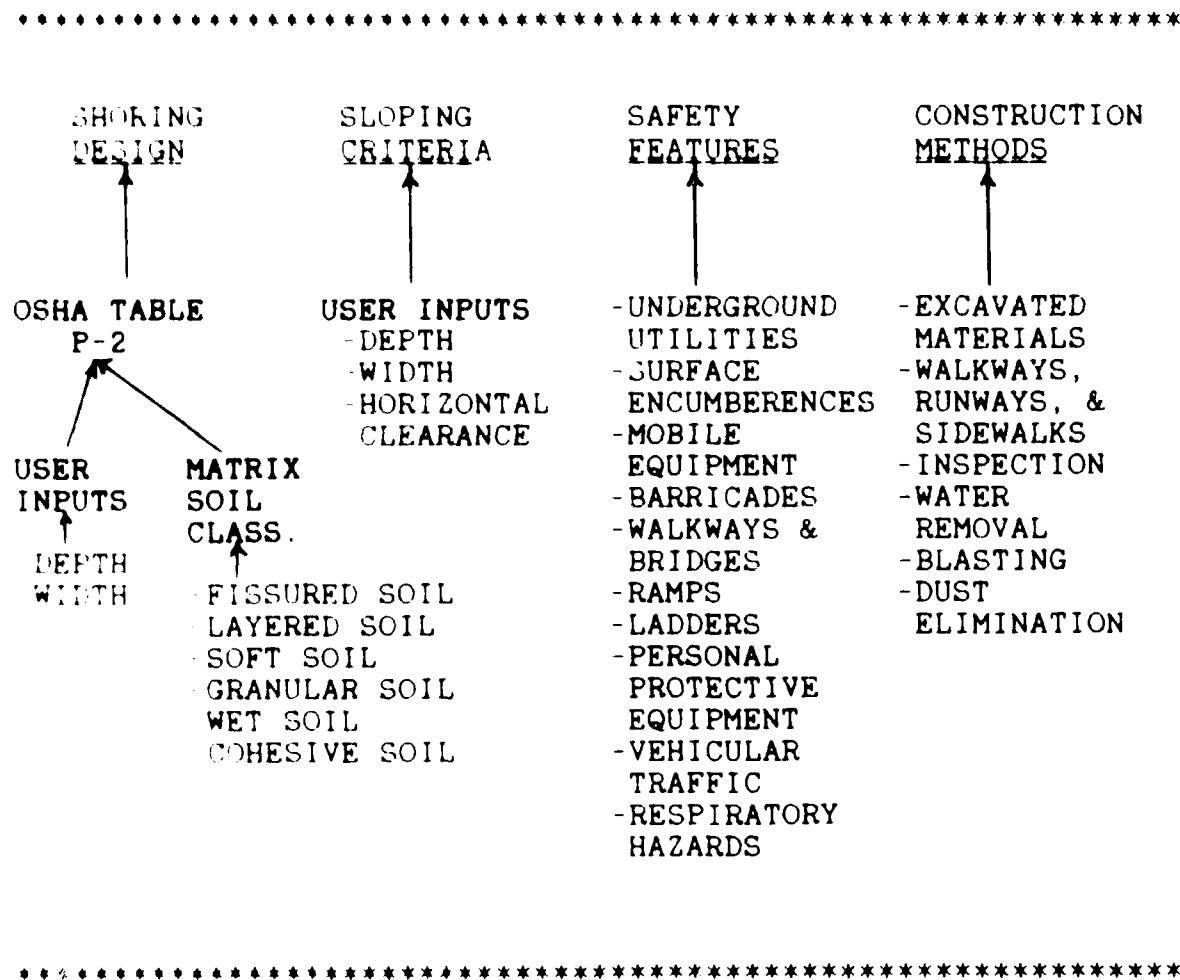

Figure 4.2 Summary of the Factors Involved in Each of the Safety Analysis Subgoals

several times. What originally seemed to be a very narrow problem seemed to have an abundance of rules and facts. The reader can get an immediate feel for this problem by spending a few minutes listing out the rules to be used to distinguish a pen from a pencil. There are many ways to handle this trivial distinction, which at its fundamental level, may not be so trivial.

Once the knowledge was sufficiently refined and the diagram began to take structure, the search for new knowledge became much more guided. Eventually the diagram was complete enough so that cause-effect relationships could be determined using all of the information acquired. This made rule writing in an IF-THEN format much easier.

Language Implementation

SFTYCHEF is a pure production system implemented using EXSYS (20), an expert system development shell. Knowledge is loaded into EXSYS directly in the form of IF-THEN rules. The rules are developed by creating a series of qualifiers and selecting the components of the qualifiers to build a rule. Figure 4.3 presents two qualifiers and Figure 4.4 demonstrates how they are used to create a rule.

The rules loaded into EXSYS were taken directly from the wall diagram. The rules were somewhat modularized due to the separation of subgoals on the diagram, but modularity is not necessary. A pure production system requires no rule ordering.

QUALIFIER #X

The primary composition of the excavated soil is

1. Fractured Rock
2. Sand
3. Silt
4. Gravel
5. Cohesive Soil

QUALIFIER #Y

The soil classification must consider

1. Layered Soil
2. Soft Soil
3. Medium Cohesive Soil
4. Wet Soil
5. Fractured Soil

FIGURE 4.3 SAMPLE QUALIFIERS

RULE #2:

IF: The primary composition of the excavated soil is
silt,

THEN: The soil classification must consider soft soil.

FIGURE 4.4 SAMPLE RULE USING QUALIFIERS #X AND #Y
FROM FIGURE 4.3

Additional features of EXSYS will be brought to light in later sections of this chapter. Chapter 5 contains a section of evaluative comments concerning its capabilities. Those interested in learning how to use EXSYS and the particular aspects involved with the loading of a knowledge base should read the EXSYS, Expert System Development Package manual (20). EXSYS is also accompanied by three tutorial sample diskettes which are very informative

Inference Structure/Chaining Mechanism

SFTYCHEF utilizes backward chaining through its knowledge base of production rules to make inferences. One of the greatest assets of EXSYS is the capability to both forward chain or backward chain. The problem addressed by SFTYCHEF is one of diagnostics, thus being goal driven. This warrants the use of backward chaining.

During a consultation session, the interpreter selects the two goal nodes, **Safe** and **Unsafe**, and backward chains through the production rules via matching consequents and antecedents until rules are selected which require user supplied data. The search strategy employed by SFTYCHEF is top down, depth first. To illustrate this, an example can be presented.

Once the goal nodes are selected at the outset of a consultation session, all rules whose consequents include **Safe** or **Unsafe** are brought forth from the knowledge base.

One of these rules might be:

```
RULE 018  IF the safety analysis reveals a sloping
           criteria which can be met
           THEN Safe   Probability = 9/10
            AND Unsafe  Probability = 1/10
           ELSE Safe   Probability = 1/10
            AND Unsafe  Probability = 9/10
```

SFTYCHEF must now evaluate this group of rules so it begins by trying to verify the antecedents of the first rule selected. Assume that rule 018 was the first rule, it would search the database and call forth all rules which provide information on the sloping criteria. One of these rules might be:

```
RULE 031: IF the depth of the trench is 5-10 feet
           AND the class of the soil is type II
           AND [Clearance] >= 7.5
           THEN the safety analysis reveals a sloping
                criteria which can be met
```

SFTYCHEF will try to evaluate the antecedents of rule 031 which will in turn verify rule 018. SFTYCHEF will not try to evaluate the second rule which was selected with rule 018 until it has been determined that rule 018 cannot be satisfied. This is what is meant by a depth first search.

Antecedents 1 and 3 of rule 031 require user input for verification. [Clearance] is the distance in feet from the edge of the trench to the nearest obstruction which might prevent excavation. SFTYCHEF asks the user for this information. Antecedent 2 calls another list of rules whose consequents classify the soil as type II. SFTYCHEF continues in this manner until a rule is reached whose antecedents can all be verified. The firing of this rule causes the path of rules to the goal node to fire as well.

During the design of a knowledge base, EXSYS allows the use of two rule selection modes, **First Rule**, or **All Rules**. First Rule causes the analysis to proceed as discussed above and the first rule to succeed among the group containing rule 018 causes an evaluation of Safe or Unsafe and the session stops. All Rules places the first evaluation on hold and proceeds to check the others as if rule 018 had not been verified. It then combines the conclusions of all of the rules on the level of rule 018 before making an analysis. SFTYCHEF should always be utilized in the All Rules mode.

Explanatory Capabilities

SFTYCHEF's explanatory capabilities are designed to respond to two types of user queries. The user may request information about a particular parameter during the consultation. He may also desire an explanation of the conclusions output at the end of the session.

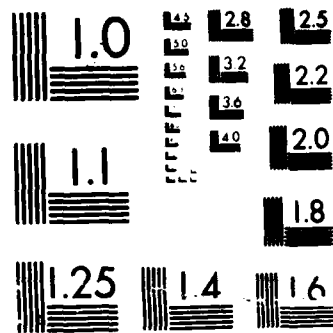

MICROCOPY RESOLUTION TEST CHART
NATIONAL BUREAU OF STANDARDS-1963-A

Questions of the first type cause a display of the current rule which the system is evaluating. The rule may contain a textual note which clarifies the rule. The rule may also contain a reference telling the user where the information for the rule was acquired.

A question of the second type causes the system to display a list of rules whose consequents directly affected the output in question. The user may prompt the system for information on the derivation of any of those rules as well. The listing of rules quickly becomes confusing to a first time user so a few guidelines should be followed.

1. At the end of a consultation, questions regarding conclusions can be answered by typing in the number of the conclusion in question and striking the return key.
2. Should the first rule or group of rules answer the question, repeated striking of the return key will lead to the output display.
3. If there is a question regarding the derivation of any of the rules from step 2, an answer may be obtained by typing in the number of the antecedent in question while the rule is displayed, and then striking the return key. SFTYCHEF will then list all the rules fired to determine all of the antecedents of the rule in question. This provides the user with much more

information than was originally requested.

4. A query into any of these rules pushes the explanation one level deeper. It is not difficult to become lost in the explanation. Some practice is required to extract exactly what is desired as quickly as possible.

SFTYCHEF has a built-in feature which should alleviate much of the need for the second type of question. Many of the rules have dummy string variables attached to them. Should one of these rules fire, the text string is output with the results. This can easily be used to alert the user to missing data or points of caution. SFTYCHEF also contains an on-line help facility which reviews most of the procedures discussed here.

Confidence Factors

Confidence factors are used to a limited extent by SFTYCHEF. Any knowledge base built using EXSYS may utilize one of three modes of goal selection. The first is a Yes/No mode which merely assigns a value of yes or no to a choice. The second mode assigns a value between 0 and 10 to a choice. A value of 0 designates absolutely no, while a value of 10 designates absolutely yes. Values from 1 to 9 allow degrees of certainty to be expressed. The third mode assigns a value

between -100 and +100 to a choice. Modes 2 and 3 require a combinatorial scheme for rules which derive similar conclusions with varying certainty. In the 0 to 10 mode, the confidence factors are simply averaged. An assignment of a 0 or a 10 to a choice by any rule, however, excludes all other confidence factors from consideration. In the -100 to +100 mode, confidence factors can be averaged or they can be combined as dependent or independent probabilities. In this mode, there are no absolutes.

A major drawback of EXSYS is that confidence factors can only be attached to rules which directly affect the final goal. In rule 018, values of 1 and 9 were attached to the selection of Unsafe and Safe. It is not possible, however, to attach confidence factors to a rule such as rule 031 which verifies rule 018. This means that uncertainty can only play a role in the selection of a goal and that the verification of subgoals must be considered absolute. This is a limiting feature.

SFTYCHEF utilizes the 0 to 10 mode and contains confidence factors for each of the rules whose consequents are goal states. The values of the confidence factors were assigned at the designer's discretion and require some clarification. As was explained earlier, the final selection of Safe or Unsafe is determined by the evaluation of four subgoals. Two rules were written. For one of them, all four subgoals were true and for the other, all four subgoals were false. The goals were given confidence factors of 10 and 0

respectively. Four rules contain one subgoal each as their antecedent. The confidence factor assigned to the goal depends upon the criticality of the subgoal to the safety of the trench. If only the shoring system were considered, Safe would receive a value of 9. If only the equipment were considered, Safe would only receive a 7. Of course in system processing, all four subgoals are evaluated. Unless all are true or all are false, the values of Safe and Unsafe provided are an average of those assigned by the four individual rules. A careful examination of rules 015-020 in Appendix IV will clarify this concept.

Incomplete Knowledge

Whenever user input is unknown, SFTYCHEF defaults to the worst case value of the requested input. In this manner, SFTYCHEF can provide an analysis even though all knowledge is not available. At the end of a consultation, the user is reminded of the information which was not known and the affect which this may have had upon the outcome. The assignment of worst case values was viewed as the only reasonable alternative in a system which evaluates safety.

Addition of New Knowledge

The fact that SFTYCHEF is a pure production system means that the addition of new knowledge is quite simple. Rule

ordering is of no importance, therefore new rules can be added at the end of the knowledge base. Deletion of existing rules is also quite simple. The tradeoff for this convenience is a loss of modularity which not only would make the system more readable, but would also decrease runtime and allow for more accurate pruning of unnecessary questions. For a shell based system the size of SFTYCHEF, however, these tradeoffs are minimal.

Summary

SFTYCHEF will assist the contractor involved in trench excavations on light commercial construction projects in performing a safety analysis. The system is a production system built using EXSYS, one of the commercially available expert system shells. SFTYCHEF backward chains from two goal nodes, Safe and Unsafe, to collect required user input and to make a diagnosis. SFTYCHEF can explain its reasoning, make educated guesses supported by confidence factors, and provide a diagnosis in spite of missing information. The knowledge base is flexible in that new rules may be added or existing ones may be deleted. Chapter 5 presents a tutorial for SFTYCHEF and a detailed explanation of its output. Chapter 6 discusses the future work to be done on SFTYCHEF as well as the merits of EXSYS.

CHAPTER 5

SFTYCHEF: A TUTORIAL

Summary of Key Points

At this point, the reader should have a sound understanding of the principles behind expert systems, the problems involved in safe trench operations, and the capabilities of the expert system prototype, SFTYCHEF. A copy of SFTYCHEF is contained in a pocket on the inside of the back cover of this report. It should not be overly optimistic to assume that the reader could now utilize the system given some basic guidance. In order to facilitate a deeper understanding of the system, however, this chapter will lead the reader through a simple scenario and a tutorial run. Before commencing with the scenario, it is important to summarize the key ideas discussed to this point upon which SFTYCHEF will rely.

The fundamental objective of the system is to provide consultative assistance to light commercial construction contractors performing a safety analysis on a trench excavation. The intended result is a scaled rating of SAFE or UNSAFE provided to the contractor.

The safety of the operation is determined after a thorough evaluation of four key aspects: (1) timber shoring design, (2) proper angle of repose, (3) appropriate safety

equipment, and (4) hazardous construction site practices.

SFTYCHEF backward chains through its rules until it reaches rules which require user input. The user is asked for information concerning various aspects of the job. SFTYCHEF utilizes a portion of the input to perform a soil analysis via the Matrix Classification System (56) detailed in Chapter 3. It combines the classification of the soil with the trench depth and width to extract a suitable timber shoring design from OSHA publication 1926, Subpart P, Table P-2 (61). A useable angle of slope is also calculated from the input data. The required safety equipment and hazardous construction practice warnings are drawn directly from OSHA publication 1926, Subpart P (61).

The user should be familiar with the construction project before consulting SFTYCHEF. The most advantageous time to use the system is after the trench has been excavated, but before any work in the trench has begun. It may, however, be used at any stage of operations. The user will need to consult the plans and specifications for the project. The user must be familiar with the project job plan, neighboring activities, site conditions, and personnel assignments. The only technical data requested is the result of a pocket penetrometer test. The unavailability of this data will not preclude an analysis but will weaken the confidence of the results.

In addition to a rating of SAFE or UNSAFE, SFTYCHEF will provide a useable timber shoring design, an allowable slope

angle, a listing of required safety features, and commentary on potentially hazardous construction practices. Those using the system only to obtain a shoring design are reminded that 75% of the system will not be utilized since it is dedicated to the overall analysis of safety.

Scenario

A contractor is faced with a trench excavation which he knows will require some analysis of safety and a shoring system, but he is not completely familiar with the items to be evaluated. No one on his small staff has the required expertise so he decides to consult SFTYCHEF as the job progresses.

A walkthrough of the site before excavation began revealed a gently sloping, lightly vegetated site with no trees, large boulders, or obstructions. The ground surface was dry. A country road cuts across the site, but passes no closer than 47 feet to the trench. The contractor noted a slight concern for men working near occasional traffic.

The planned trench is to be 200 yards long, 12 feet deep at its maximum, and less than 7 feet wide to facilitate the installation of a gravity flow sewer line. Underground utilities are not expected to be a problem. No supporting earthwork will be necessary.

The job will progress quickly and can be done with 2 backhoes and a front-end loader. The trench needs to be

bridged at one point near the middle to allow workers to cross. One end of the trench is to slope up to ground level so no ramps or ladders are needed. The only other work on the site involves material hauling and staging by flatbed trucks. The assigned safety inspector has thoroughly analyzed the job and has pointed out a possible dust hazard and a potential fume problem. Oxygen deficiency or flammable gases cause no concern. Figure 5.1 depicts this particular project in plan view and in elevation.

After excavation begins, the trench walls reveal a homogeneous soil of clay-like consistency. The soil is moist and does not spall or flake off the trench wall. Vegetation or previous disturbances have not seriously fissured the soil. A handful of the excavated soil can be molded with strong finger pressure and penetrated with the thumb with moderate effort. The excavation foreman reports a penetrometer reading of 1.30 tons per square foot. With this information available, the contractor can utilize SFTYCHEF.

Tutorial Run

User's Instructions

The description of the tutorial run refers regularly to screens displayed by the system. Printouts of these screens are included at the end of this chapter and should be referred to continually. Best results are achieved when the reader runs the system along with the tutorial.

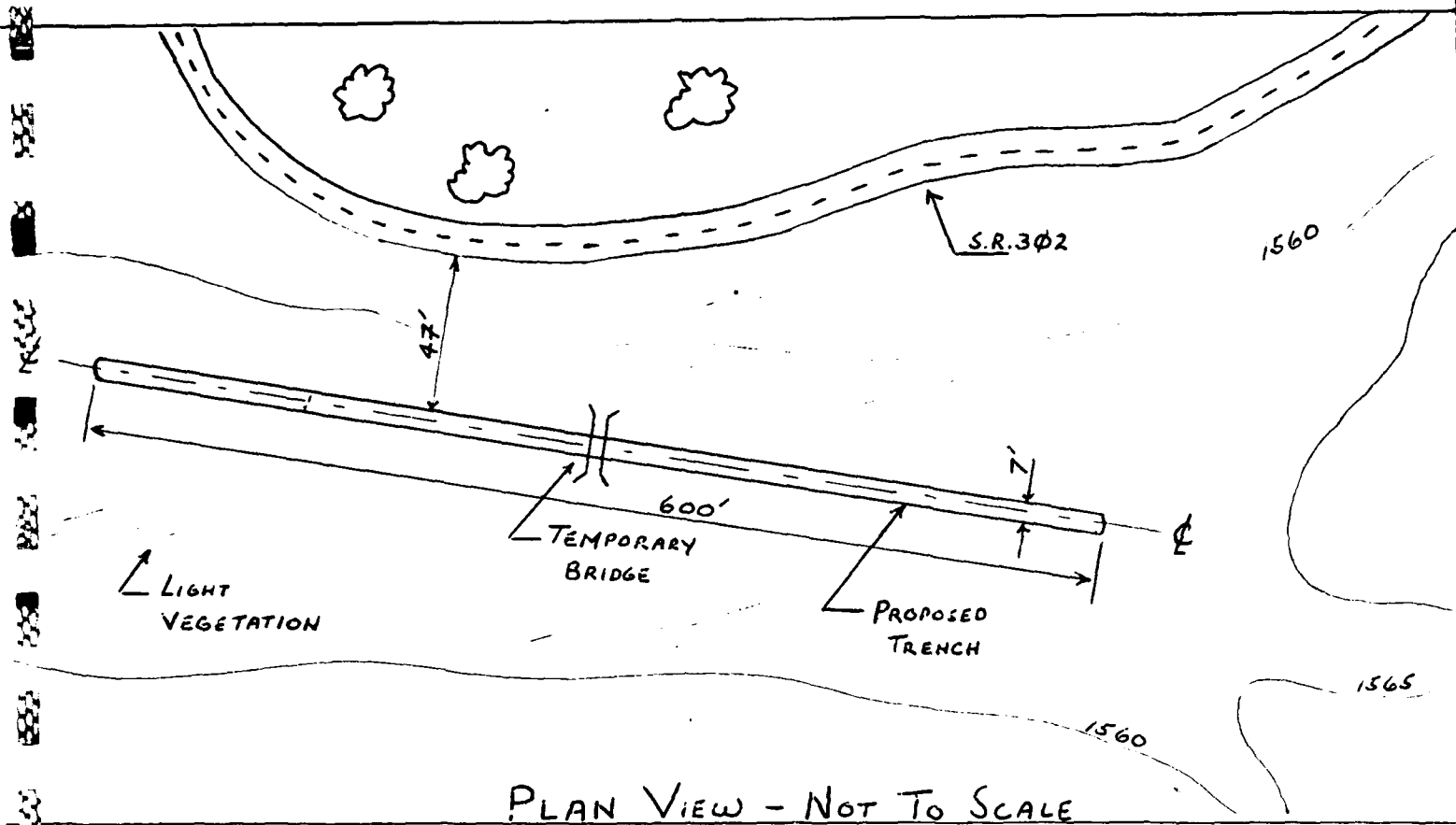

PLAN VIEW - NOT TO SCALE

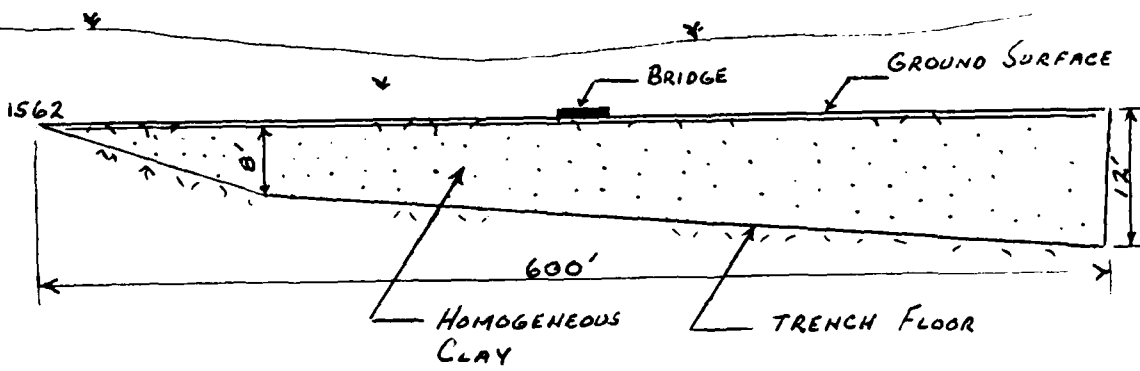

PROFILE VIEW - NOT TO SCALE

Figure 5.1 Scenario Sketches

SFTYCHEF is on a single floppy disk and is self booting so that the user needs no other disks. The only equipment required is an IBM Personal Computer with a minimum of 256K RAM and one floppy disk drive. Any IBM compatible system will also work. A monochrome or multicolor screen can be used. A printer is helpful but is not necessary.

Loading the system is not difficult. The disk is first inserted into the floppy drive, label side up and the notched side on the left of the user. After inserting the disk and closing the dust cover, the PC is turned on. The system takes over from there. The PC will first request the current date. Pressing the RETURN key twice at this point obtains the A-prompt (A>).

At the A>, the user should type the words EXSYS SFTYCHEF with one space between them. They need not be typed in capital letters. After hitting the RETURN key once more, the system takes over and Screen 1 is displayed.

Screen Analysis

Pressing any key causes Screen 2 to be displayed. A first time user of SFTYCHEF should answer yes to this first question. The system has excellent instructions contained in an initial, brief presentation.

Following the instructions, or by answering no, Screen 3 is displayed. Unless one is doing in-depth study of the system and its rules, one should always answer no or hit return when asked if a rule display is desired. Answering

yes causes an overabundance of unnecessary information to be presented to the user and triples the time needed for a run. Screens 4 and 5 complete the introduction and Screen initiates the analysis.

SFTYCHEF asks the user questions by displaying a list of options to the user. The user answers the question by typing the number of the desired response and hitting RETURN. SFTYCHEF refers to the RETURN key as ENTER. Multiple answers are permitted, where appropriate, and are entered by typing all of the desired numbers, separated by commas.

The menu at the bottom of Screen 6 appears with every question. Typing WHY instead of a number prompts the system to display the series of rules which it is using to reach a conclusion. This will be investigated later. Typing QUIT allows the user to save all of his input data to this point, turn off the the system, and return to it later. Typing <H>, help, provides the user with further guidance.

As displayed in Screen 6, the proper response for the scenario is 3, 10-15 feet, thus 3 and ENTER were typed. Screens 7 to 35 were generated using the data from the scenario and should be carefully reviewed by the reader.

Screens 9 to 13 provide an example of what is produced when WHY is typed. Screens 10, 11, 12, and 13 display the rules which the system is trying to evaluate at this point. Typing ENTER causes the screens to advance.

It should be noted in Screen 10 that the menu at the bottom has changed. Input of a line number in the IF

condition will display all rules used to verify or refute that condition. <K> causes a listing of all known data input so far. <C> lists the users choices for Screen 9. <R> provides the textual reference from which the rule was obtained. ↑ or ↓ displays the next consecutive rule, <J> jumps to a rule of the user's choosing. At this point, the user should merely type ENTER and proceed.

A sample of a multiple response is shown in Screen 22. The response indicates that there is some threat of hazardous dusts or fumes.

Completion of the scenario brings the user to Screen 36. Screen 36 briefly introduces the results of the analysis which will follow.

Screens 37, 38, and 39 are the results of the analysis and should be carefully read.

Line 1 of Screen 37 gives the operation a rating of SAFE with a value of 10, the highest attainable. Lines 2 through 8 provide shoring information. The rest is self explanatory.

The bottom of Screen 39 reveals a new menu. <H> will explain what each choice will do. At this point, the user should type <C>, which will allow him to change any input data and rerun the system.

In screen 40, it is indicated that line 10 is to be changed. Line 10 is a statement which says that the employees will be exposed to vehicular traffic. The change to be made will state that it is unknown if the employees will be exposed to vehicular traffic. This change should

cause the value of SAFE to decrease, the value of UNSAFE to increase, and a text note to be added to the results. Screen 41 redisplay the question, and a new answer is given. This will return the system screen 40. Typing <R> will run the new data and yield screen 42.

As may be quickly noted, the results have changed from SAFE 10, UNSAFE 0, to SAFE 7, UNSAFE 3. This indicates an unsafe condition has been detected. Line 19 on Screen 44 informs the user of the problem. The procedure for tracing the rules which identified the problem is begun by typing the number 2, the line number of UNSAFE, at the bottom of Screen 44.

The system redisplay the final level of rules used to perform the analysis. Screen 45, 46, and 47 display these rules. The highlighting of Screen 47 informs the user that an improper accounting of all miscellaneous safety features has occurred. At this point, typing the number 1 will give the derivation of that condition.

By typing ENTER, one reaches Screens 49 and 50. To find out which miscellaneous safety feature was neglected, type in any line number from 1 to 10. A careful review of Screens 51 to 58 shows rules which fired to validate all the conditions of Screen 49 except line number 9, employee exposure to vehicular traffic.

By continuing to press enter, Screens 59 to 64 are displayed, each giving a new rule which was essential to the safety analysis. Had the missing item not been found, each

of these rules would need to be searched as shown in Screen 49.

Tracing rules in this manner is difficult and confusing. It is easy to get "nested" in 5 or 6 levels of explanation and rule displays. One can always return to the results display by repeatedly pressing the RETURN key. Most often, the cause of an UNSAFE rating is listed along with the results. Rule tracing is not necessary unless there is some problem or question which the results listing does not answer. Competent rule tracing can only be achieved through experience. It is, however, highly educational to attempt it.

```
#####  
:  
:  
:           E X S Y S           :  
:  
:   Expert System Runtime Program   :  
:  
:  
:   (c) copyright 1983,84,85 EXSYS, Inc.   :  
:  
:  
:  
:           Ver. 3.1.9           :  
:  
#####
```

Press any key to start:

Screen 1

Do you wish instruction on running the program? (Y/N):

Screen 2

Do you wish to have the rules displayed as
they are used? (Y/N) (Default=N):

Screen 3

:
: SAFETY ANALYSIS OF TRENCHES :
:
#####

by: Thomas C. Nicholas, LT,CEC,USN

Press any key to start:

Screen 4

SFLYCHEF is a prototype production system developed by J.C. Nicholas in partial fulfillment of the requirements for a Master of Engineering Degree in Civil Engineering, Construction Management at The Pennsylvania State University. This system is designed to assist in the safety analysis of light commercial trenching operations. It requires input on the soil conditions of the trenching site, although the only exact measurements required are to be done with a pocket penetrometer. No laboratory analysis is needed. The system also requires input on the trench itself, i.e. depth, width, etc. All other required input can easily be acquired without any research on your part.

For the most accurate results, run SFLYCHEF before opening the trench and answer all questions that can be answered. Then, store the data and rerun SFLYCHEF after opening the trench. Don't forget to recall the stored data.

When the analysis is complete, SFLYCHEF will give your operation a rating of safe or unsafe and will provide you with a proper shoring system design, the sloping criteria that must be met, any miscellaneous safety features that may be needed, and the effect of any unusual site construction methods.

Press any key to start:

Screen 5

The depth of the trench is

- 1 0-5 feet
- 2 5-10 feet
- 3 10-15 feet
- 4 15-20 feet
- 5 20+ feet
- 6 Unknown.

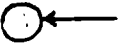

#####

Enter number(s) of value(s), WHY for information on the rule,
QUIT to save data entered or <H> for help

Screen 6

Investigation of the trench walls and floor reveals

- 1 layered soil, with the slope of the layers dipping toward the trench
- 2 layered soil, with the slope of the layers dipping away from the trench
- 3 layered soil, with the slope of the layers not known
- 4 homogeneous soil
- 5 unknown

4

Enter number(s) of value(s). WHY for information on the rule.
QUIT to save data entered or <H> for help

Screen 7

The primary composition of the excavated soils is

- 1 fractured rock
- 2 gravel
- 3 sand
- 4 silt (very fine sand)
- 5 cohesive (clay-like) soil

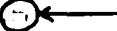

Enter number(s) of value(s). WHY for information on the rule.
QUIT to save data entered or <H> for help

Screen 8

Please input the unconfined compressive strength of the soil in the wall of the trench measured with a pocket penetrometer in tons per square foot (tsf)

: WHY

.....

Input a value for the variable between 0.000000 and 10.000000

WHY for information, or 'QUIT' to save data:

Screen 9

RULE NUMBER: 75

IF:

(1) The primary composition of the excavated soils is cohesive (clay-like) soil

and (2) (PENETROMETER) < 0.5

THEN:

Investigation of the trench walls and excavated soils reveals soft soils

NOTE: Soft Soils are cohesive soils with an unconfined compressive strength (pocket penetrometer reading) of 0.5 tsf or less and granular soils that can not stand on a slope of 3 horizontal to 1 vertical without slumping much.

IF line # for derivation. <K>-known data. <C>-choices. <R>-reference.
or - prev. or next rule. <J>-jump. <H>-help or <ENTER> to continue:

RULE NUMBER: 45

IF:

(1) Investigation of the trench walls and excavated soils reveals inclined layers dipping to the trench

THEN:

The class of soil is type IV

#####

IF line # for derivation, <K>-known data, <C>-choices
or - prev. or next rule, <J>-jump, <H>-help or <ENTER> to continue:

Screen 11

RULE NUMBER: 15

IF:

- (1) The safety analysis reveals a shoring design which can be met
- and (2) The safety analysis reveals sloping criteria which can be met
- and (3) The safety analysis reveals an accounting of all miscellaneous safety features
- and (4) The safety analysis reveals an evaluation of any unusual construction activities

THEN:

- SAFE - Probability=10/10
- and UNSAFE - Probability=0/10

IF line # for derivation, <k>-known data, <C>-choices
or - prev. or next rule, <J>-jump, <H>-help or <ENTER> to continue:

Please input the unconfined compressive strength of the soil in the wall of the trench measured with a pocket penetrometer in tons per square foot (tsf)
: 1.30

input a value for the variable between 0.000000 and 10.000000
WHY for information, or 'QUIT' to save data:

Screen 14

The undisturbed soil surrounding the trench can

- 1 be easily penetrated several inches by your fist or it exudes between your fingers when squeezed in your hand
- 2 be easily penetrated several inches by your thumb or molded by light finger pressure
- 3 be penetrated several inches by your thumb with moderate effort or molded by strong finger pressure
- 4 be readily indented by your thumb but penetrated only with great effort
- 5 be readily indented by your thumb nail
- 6 be indented with difficulty by your thumb nail

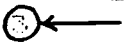

enter number(s) of value(s). WHY for information on the rule,
QUIT to save data entered or <H> for help

The trench walls, or the trench floor is

- 1 dry
- 2 moist
- 3 wet
- 4 submerged or draining water



Enter number(s) of value(s), WHY for information on the rule,
QUIT to save data entered or <H> for help

Screen 16

- Examination of the soil surface surrounding the excavation reveals
- 1 cracks penetrating deeper than 25% of the trench depth (look at the trench wall)
 - 2 signs of previous disturbance (crossing underground utility lines are an example)
 - 3 vegetation that would suggest a fissured subsurface condition
 - 4 none of the above

4 ←

Enter number(s) of value(s). WHY for information on the rule.
QUIT to save data entered or <H> for help

Screen 17

The soil composing the trench walls is
1 spalling of in chunks (chipping or flaking)
2 not spalling



Enter number(s) of value(s). WHY for information on the rule.
QUIT to save data entered or <H> for help

Screen 18

Please input the minimum, horizontal clearance, in feet, from the planned top edge of the trench to the nearest obstruction that might limit excavation:
: 47

Input a value for the variable greater than 0.000000
'WHY' for information, or 'QUIT' to save data:

Screen 19

The width of the trench is

- 1 0-3 feet
- 2 3-6 feet
- 3 6-9 feet
- 4 9-12 feet
- 5 12-15 feet
- 6 Unknown



Enter number(s) of value(s). WHY for information on the rule,
QUIT to save data entered or <H> for help

Screen 20

There is some indication of

- 1 hazardous dusts
- 2 gases
- 3 fumes
- 4 mists
- 5 oxygen deficiencies
- 6 none of the above
- 7 unknown

1.3

Enter number(s) of value(s), WHY for information on the rule.
QUIT to save data entered or <H> for help

Screen 22

employees

- 1 will be exposed to vehicular traffic
- 2 will not be exposed to vehicular traffic
- 3 unknown

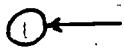

Enter number(s) of value(s). WHY for information on the rule.
QUIT to save data entered or <H> for help

Screen 23

the construction site will contain or contains

- 1 supporting trenches
- 2 wells
- 3 pits
- 4 shafts
- 5 none of the above
- 6 unknown

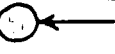

Enter number(s) of value(s). WHY for information on the rule.
QUIT to save data entered or <H> for help

Screen 24

The trench

- 1 needs to be crossed over by men or equipment
- 2 will not be crossed

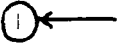

(enter number(s) of value(s), WHY for information on the rule,
<S> to save data entered or <H> for help

Screen 25

The construction site contains

- 1 mobile equipment operating in the vicinity of the excavation (include excavators)
- 2 no mobile equipment
- 3 unknown



Enter number(s) of value(s), WHY for information on the rule.
QUIT to save data entered or <H> for help

Screen 26

Preliminary investigation of the excavation site reveals

- 1 trees
- 2 boulders
- 3 other surface encumbrances
- 4 none of the above
- 5 unknown, did not investigate

4

Enter number(s) of value(s), WHY for information on the rule,
QUIT to save data entered or <H> for help

Screen 28

The area around the trench will need

- 1 walkways
- 2 runways
- 3 sidewalks
- 4 none of the above
- 5 unknown

4 ←

Enter number(s) of value(s). WHY for information on the rule.
QUIT to save data entered or <H> for help

Screen 29

Examination of the soil surface before excavation reveals

- 1 surface water
- 2 no surface water



Enter number(s) of value(s). WHY for information on the rule.
QUIT to save data entered or <H> for help

Screen 30

Extreme dust conditions are

- 1 anticipated
- 2 not anticipated
- 3 unknown

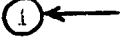

.....
Enter number(s) of value(s). WHY for information on the rule.
[Y] to save data entered or <H> for help

Screen 32

French workers are likely to be exposed to

- 1 oxygen deficiency
- 2 flammable gas
- 3 none of the above
- 4 unknown



Enter number(s) of value(s). WHY for information on the rule,
QUIT to save data entered or <H> for help

Screen 33

Crew personnel assignments include provisions for

- 1 a safety inspector
- 2 no safety inspector
- 3 undecided

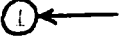

Enter number(s) of value(s). WHY for information on the rule.
QUIT to save data entered or <H> for help

Screen 34

the design of the shoring is to be done

- 1) by a licensed engineer, because of particular concerns
- 2) by experienced workmen in the field following Sftychef's recommendations



Enter number(s) of value(s). WHY for information on the rule.
0001 to save data entered or <H> for help

Screen 35

Please press any key to see the results of the safety analysis run. The results will each be assigned a number from 0 to 10, 10 meaning absolutely yes, and 0 meaning absolutely no. Because of the extreme importance of having an absolutely safe trenching operation, if the analysis results indicate unsafe or safe but the value is less than 10, retrace the rules used to arrive at this conclusion and find out why your trench is considered less than safe. Perhaps a minor adjustment in your procedures will save a life.

Press any key to display results:

Screen 36

Values based on 0 - 10 system

VALUE

- 1 SAFE
- 2 The required minimum dimensions for the trench sheeting are = (2 X 6) OR (3 X 4)
- 3 The maximum sheeting center to center spacing = CLOSE
- 4 The minimum dimensions of the wales = (4 X 6)
- 5 The maximum center to center wale spacing = 4 FEET
- 6 The minimum dimensions of the struts = (6 X 8)
- 7 The maximum vertical center to center spacing of the struts = 4 FEET
- 8 The maximum horizontal spacing of the struts = 6 FEET
- 9 The steepest allowable side-slope, Hor:Vert = (1 1/2 : 1)
- 10 The presence of mobile equipment in the vicinity of the excavation may require the use of stop logs or barricades. In any case, the grade must be sloped away from the excavation.
- 11 Where employees or equipment are required or permitted to cross over excavations, walkways or bridges with standard guardrails shall be provided.
- 12 Personal protective equipment is required for the hands, eyes, head, feet, and lungs in all trenches and other protective equipment may be needed as conditions dictate. Review OSHA 1926, Subpart E.

#####

Press any key for more:

13 Employees exposed to vehicular traffic shall be provided with and shall be instructed to wear warning vests marked with or made of reflectorized or high visibility material.

14 Conditions indicate the presence of hazardous dusts, gases, fumes, mists, or an oxygen deficiency. Approved respiratory protection is required. Consult OSHA 1926, Subpart D.

15 Daily inspections of excavations shall be made by a competent person. If evidence of possible cave-ins or slides is apparent, all work in the trench shall cease until the necessary precautions have been taken to safeguard the employees. Excavations shall be inspected by a competent person after every rainstorm or other hazard-increasing occurrence, and the protection against slides and cave-ins shall be increased if necessary.

16 Dust conditions shall be kept to a minimum by the use of water, salt, calcium chloride, oil, or other means.

17 Excavated material shall be effectively stored and retained at least 2 feet or more from the edge of the excavation. The employer may use effective barriers or other effective retaining devices in lieu thereof in order to prevent excavated or other materials from falling into the excavation.

18 If the slope of the backfill behind the trench exceeds 3 Hor.: 1

Press any key for more:

When workers in the trench must be protected against objects falling or sliding from the sloped backfill. This can be accomplished by projecting the sheeting at least 18" above the ground surface or by a specially constructed protective sill.

(1) choices <A>, only if value>1 <G>, Print <P>, Change and rerun <C>,
files used :line number<. Quit/save <Q>, Help <H>, Done <D>: C

Screen 39

- 1 The depth of the trench is 10-15 feet
- 2 The width of the trench is 6-9 feet
- 3 The design of the shoring is to be done by experienced workmen in the field following Sftychef's recommendations
- 4 Examination of the soil surface before excavation reveals no surface water
- 5 The plans, specifications, or any other contract documents or field studies indicate no utilities whatsoever
- 6 Preliminary investigation of the excavation site reveals none of the above
- 7 The construction site contains mobile equipment operating in the vicinity of the excavation (include excavators)
- 8 The construction site will contain or contains none of the above
- 9 The trench needs to be crossed over by men or equipment
- 10 — Employees will be exposed to vehicular traffic
- 11 There is some indication of hazardous dusts and fumes
- 12 The area around the trench will need none of the above
- 13 Crew personnel assignments include provisions for a safety inspector
- 14 Construction operations on the site will require no blasting
- 15 Extreme dust conditions are anticipated
- 16 Trench workers are likely to be exposed to none of the above

Enter number of line to change, <O> for original data, <R> to run the data, <H> for help or any other key for MORE DATA: 10

*** The number 10 was entered because the input concerning the exposure of workmen to vehicular traffic will be changed. See page 99.

Values based on 0 - 10 system

VALUE PREV.

- | | | | | | |
|---|--------|---|---|---|----|
| 1 | SAFE | → | { | 7 | 10 |
| 2 | UNSAFE | | | 3 | 0 |
- 3 The required minimum dimensions for the trench sheeting are = (2 X 6) OR (3 X 4)
- 4 The maximum sheeting center to center spacing = CLOSE
- 5 The minimum dimensions of the wales = (4 X 6)
- 6 The maximum center to center wale spacing = 4 FEET
- 7 The minimum dimensions of the struts = (6 X 8)
- 8 The maximum vertical center to center spacing of the struts = 4 FEET
- 9 The maximum horizontal spacing of the struts = 6 FEET
- 10 The steepest allowable side-slope, Hor:Vert = (1 1/2 : 1)
- 11 The presence of mobile equipment in the vicinity of the excavation may require the use of stop logs or barricades. In any case, the grade must be sloped away from the excavation.
- 12 Where employees or equipment are required or permitted to cross over excavations, walkways or bridges with standard guardrails shall be provided.
- 13 Personal protective equipment is required for the hands, eyes, head, feet, and lungs in all trenches and other protective equipment may be

Press any key for more:

needed as conditions dictate. Review OSHA 1926, Subpart E.

14 Conditions indicate the presence of hazardous dusts, gases, fumes, mists, or an oxygen deficiency. Approved respiratory protection is required. Consult OSHA 1926, Subpart D.

15 Daily inspections of excavations shall be made by a competent person. If evidence of possible cave-ins or slides is apparent, all work in the trench shall cease until the necessary precautions have been taken to safeguard the employees. Excavations shall be inspected by a competent person after every rainstorm or other hazard-increasing occurrence, and the protection against slides and cave-ins shall be increased if necessary.

16 Dust conditions shall be kept to a minimum by the use of water, salt, calcium chloride, oil, or other means.

17 Excavated material shall be effectively stored and retained at least 2 feet or more from the edge of the excavation. The employer may use effective barriers or other effective retaining devices in lieu thereof in order to prevent excavated or other materials from falling into the excavation.

18 If the slope of the backfill behind the trench exceeds 3 Hor.: 1 Vert., workers in the trench must be protected against objects rolling or sliding from the sloped backfill. This can be accomplished by

Press any key for more:

RULE NUMBER: 19

IF:

(1) The safety analysis reveals an accounting of all miscellaneous
safety features

THEN:

and SAFE - Probability=7/10
 UNSAFE - Probability=3/10

ELSE:

and SAFE - Probability=3/10
 UNSAFE - Probability=7/10

P line # for derivation, <K>-known data, <C>-choices
or - prev. or next rule, <J>-jump, <H>-help or <ENTER> to continue: 1

RULE NUMBER: 26

IF:

- (1) The depth of the trench is 10-15 feet
- and (2) The class of soil is type III
- and (3) [CLEARANCE] \geq 22.5

THEN:

The safety analysis reveals sloping criteria which can be met

IF line # for derivation, <K>-known data, <C>-choices
or - prev. or next rule, <J>-jump, <H>-help or <ENTER> to continue:

RULE NUMBER: 40

IF:

- (1) An accounting of all miscellaneous safety features reveals consideration of location of underground utilities
- and (2) An accounting of all miscellaneous safety features reveals consideration of removal of surface encumbrances
- and (3) An accounting of all miscellaneous safety features reveals consideration of use of mobile equipment
- and (4) An accounting of all miscellaneous safety features reveals consideration of adequate barrier physical protection
- and (5) An accounting of all miscellaneous safety features reveals consideration of walkways and bridges
- and (6) An accounting of all miscellaneous safety features reveals consideration of ramps
- and (7) An accounting of all miscellaneous safety features reveals consideration of ladders
- and (8) An accounting of all miscellaneous safety features reveals consideration of personal protective equipment
- and (9) An accounting of all miscellaneous safety features reveals consideration of employees exposed to vehicular traffic
- and (10) An accounting of all miscellaneous safety features reveals

#####

Press any key for more:

consideration of special respiratory considerations

THEN:

The safety analysis reveals an accounting of all miscellaneous safety features

ELSE:

The safety analysis reveals a failure to account for all miscellaneous safety features

#####

If line # for derivation, <K>-known data, <C>-choices, <R>-reference, or - prev. or next rule, <J>-jump, <H>-help or <ENTER> to continue:

RULE NUMBER: 59
IF:

(1) The construction site will contain or contains none of the above

THEN:

An accounting of all miscellaneous safety features reveals
consideration of adequate barrier physical protection

IF line # for derivation. <K>-known data, <C>-choices
or - prev. or next rule. <J>-jump, <H>-help or <ENTER> to continue:

RULE NUMBER: 62

IF:

- (1) The plans, specifications, or any other contract documents or field studies indicate no utilities whatsoever

THEN:

An accounting of all miscellaneous safety features reveals consideration of location of underground utilities

!!
IF line # for derivation. <K>-known data, <C>-choices, <R>-reference,
or - prev. or next rule. <J>-jump, <H>-help or <ENTER> to continue:

RULE NUMBER: 61

IF:

(1) There is some indication of hazardous dusts or gases or fumes or mists or oxygen deficiencies

THEN:

Conditions indicate the presence of hazardous dusts, gases, fumes, mists, or an oxygen deficiency. Approved respiratory protection is required. Consult OSHA 1926, Subpart D.

and An accounting of all miscellaneous safety features reveals consideration of special respiratory considerations

#####

Line # for derivation, <K>-known data, <C>-choices, <R>-reference, or - one, or next rule, <J>-jump, <H>-help or <ENTER> to continue:

RULE NUMBER: 65

IF:

- (1) The depth of the trench is 0-5 feet or 5-10 feet or 10-15 feet or 15-20 feet or 20+ feet or Unknown

THEN:

Personal protective equipment is required for the hands, eyes, head, feet, and lungs in all trenches and other protective equipment may be needed as conditions dictate. Review OSHA 1926. Subpart E.

and An accounting of all miscellaneous safety features reveals consideration of personal protective equipment

F line # for derivation, <k>-known data, <C>-choices, <R>-reference, or - prev. or next rule, <J>-jump, <H>-help or <ENTER> to continue:

RULE NUMBER: 68
IF:

(1) The trench needs to be crossed over by men or equipment

THEN:

Where employees or equipment are required or permitted to cross over excavations, walkways or bridges with standard guardrails shall be provided.

and An accounting of all miscellaneous safety features reveals consideration of walkways and bridges

.....
IF line # for derivation. <K>-known data, <C>-choices, <R>-reference,
or - prev. or next rule. <J>-jump, <H>-help or <ENTER> to continue:

RULE NUMBER: 70

IF:

01: The construction site contains mobile equipment operating in the vicinity of the excavation (include excavators)

THEN:

The presence of mobile equipment in the vicinity of the excavation may require the use of stop logs or barricades. In any case, the grade must be sloped away from the excavation.

and An accounting of all miscellaneous safety features reveals consideration of use of mobile equipment

F line # for derivation. <K>-known data. <C>-choices. <R>-reference.
or - prev. or next rule. <J>-jump, <H>-help or <ENTER> to continue:

Screen 57

RULE NUMBER: 43

IF:

- (1) The depth of the trench is 0-5 feet or 5-10 feet or 10-15 feet or 15-20 feet
- and (2) The class of soil is type I or type II or type III or type IV
- and (3) The width of the trench is 0-3 feet or 3-6 feet or 6-9 feet or 9-12 feet or 12-15 feet

THEN:

The safety analysis reveals a shoring design which can be met

ELSE:

Due to missing information, SFTYCHEF is not able to make a proper safety analysis of the trench shoring requirements. Please check the plans for trench depth and width and attempt to answer all questions relating to the soil characteristics so that a shoring recommendation can be made.

IF line # for derivation. <K>-known data. <C>-choices
or - prev. or next rule. <J>-jump. <H>-help or <ENTER> to continue:

RULE NUMBER: 19

IF:

(1) The safety analysis reveals an accounting of all miscellaneous safety features

THEN:

and SAFE - Probability=7/10
UNSAFE - Probability=3/10

ELSE:

and SAFE - Probability=3/10
UNSAFE - Probability=7/10

IF line # for derivation. <K>-known data, <C>-choices
or - prev. or next rule. <J>-jump, <H>-help or <ENTER> to continue:

Screen 62

RULE NUMBER: 20

IF:

(1) The safety analysis reveals an evaluation of any unusual construction activities

THEN:

SAFE - Probability=7/10
and
UNSAFE - Probability=3/10

ELSE:

and
SAFE - Probability=3/10
UNSAFE - Probability=7/10

IF line # for derivation. <K>-known data, <C>-choices
or - prev. or next rule. <J>-jump, <H>-help or <ENTER> to continue:

Screen 63

Values based on 0 - 10 system

VALUE PREV.

- 1 SAFE
- 2 UNSAFE
- 3 The required minimum dimensions for the trench sheeting are = (2 X 6) OR (3 X 4)
- 4 The maximum sheeting center to center spacing = CLOSE
- 5 The minimum dimensions of the wales = (4 X 6)
- 6 The maximum center to center wale spacing = 4 FEET
- 7 The minimum dimensions of the struts = (6 X 8)
- 8 The maximum vertical center to center spacing of the struts = 4 FEET
- 9 The maximum horizontal spacing of the struts = 6 FEET
- 10 The steepest allowable side-slope, Hor:Vert = (1 1/2 : 1)
- 11 The presence of mobile equipment in the vicinity of the excavation may require the use of stop logs or barricades. In any case, the grade must be sloped away from the excavation.
- 12 Where employees or equipment are required or permitted to cross over excavations, walkways or bridges with standard guardrails shall be provided.
- 13 Personal protective equipment is required for the hands, eyes, head, feet, and lungs in all trenches and other protective equipment may be

Press any key for more:

Summary

This chapter reviewed the fundamental objective of SFTYCHEF. It then presented the four key safety aspects of the trench operation which would be evaluated. A brief discussion of SFTYCHEF's evaluative procedures and knowledge base preceded comments concerning the optimum conditions for use of the system. In order to acquaint the novice with the details of system utilization, a short scenario was presented and a "screen by screen" tutorial run of the system was provided.

CHAPTER 6

CONCLUSIONS AND RECOMMENDATIONS

Summary

Problem Domain

Trench cave-ins are a serious problem in construction today and their elimination can only be facilitated by increased awareness and improved techniques of safety analysis. The light commercial contractor faced with excavating a short term trench has a variety of problems to consider while being bound by time and financial constraints. The contractor's main objective is satisfactory stabilization of the trench walls. The soil must be analyzed, the appropriate sloping angles must be investigated, and an adequate timber shoring system must be designed. Safety encompasses far more than trench wall stabilization, however, so the contractor must review the safety equipment to be supplied to the personnel and the jobsite as well as the potential hazards in the trench resulting from the surrounding construction.

Suitability for Expert Systems

The problem is very well suited to solution via expert systems. There are experts in the field of trench safety and

their expertise is widespread. It is certain that jobsites which have received expert attention are on the whole safer than those that have been neglected. A proper safety analysis is not lengthy with the exception of the soil analysis and the design of a shoring system. Using the Matrix Classification System and tables, however, the entire problem can be solved in a matter of hours. Anyone who has worked in a trench is well aware that the problem is ill-structured. Every site has different conditions and obstacles. These varied conditions coupled with time constraints, financial constraints, and the non-availability of technical expertise, often lead to safety analyses based upon the subjective knowledge of the workers on the site. The rewards of a safe trench are perhaps not obvious, but the consequences of an unsafe trench are known to all.

Construction of SFTYCHEF

SFTYCHEF is a production system built using EXSYS, an expert system shell, to assist the contractor faced with this problem. The system takes input from the contractor concerning trench parameters, soil conditions, and jobsite characteristics, performs a safety analysis, and outputs a statement concerning the degree of safety, a recommended timber shoring design, an allowable slope angle, and a listing of safety procedures and equipment required on the job.

SFTYCHEF utilizes backward chaining to derive

inferences. It has the ability to answer questions about its reasoning both during and after a consultation session. Confidence factors have been employed to provide the user with a degree of certainty in the analysis. The system will provide an analysis and recommendations based on worst case default values, if user input be incomplete. The simplicity of a pure production system allows modification of the knowledge base at any time through the addition of new rules or the deletion of existing rules. Rule ordering need not be considered.

SFTYCHEF

Current Stage of Development

SFTYCHEF is a functioning prototype which is currently capable of carrying out the above analysis. In its present condition, the system forms the foundation for a fully developed expert system.

Needed Work

The principal work remaining involves validation of the knowledge base through extensive expert interaction. It is certain that such interaction would expand and modify the rule base. The system must then be subjected to an intensive period of testing. SFTYCHEF should be distributed to a number of contractors in an observable field environment. The conclusions and recommendations of SFTYCHEF should then

be compared to those of the contractor's experts.

There are particular areas of the knowledge base which would benefit from further work. Although OSHA 1926 Table P-2 is currently the legal standard, it is very difficult to support the recommended designs with engineering calculations. The pressure calculations resulting from soil classification using the Matrix System can and have been used to develop similar tables (58). Work needs to be done in the area of verification of these tables so that they might replace Table P-2 in SFTYCHEF. Many engineers question the validity of tabular designed shoring systems due to the overabundance of site particular variables. A substantial addition to SFTYCHEF would be a link to a computational program which does the actual design of the shoring system. A simple beam supported on springs might provide an interesting model of analysis.

SFTYCHEF would benefit from the addition of alternate modes of trench wall stabilization. Trench jacks, hydraulic shores, and trench boxes all receive considerable field use. Their addition to SFTYCHEF would provide added flexibility to the contractor.

SFTYCHEF currently lists vital safety equipment and reference sources containing the details of the use or assembling of such equipment. SFTYCHEF could be expanded by providing a database of one page textual explanations covering the material from each reference. This would allow the user to get more elaborate answers to some of his

questions.

SFTYCHEF currently contains no information on lumber. Should the system be expanded to incorporate design capabilities, extensive data on lumber properties would have to be included in the system.

Modification

As has been mentioned several times throughout this report, the unimportance of rule ordering makes the addition of new knowledge to SFTYCHEF relatively simple. The bulk of the effort lies in knowledge acquisition and representation. As the system grows in content, it may become necessary to modularize the rules to increase readability, reduce run time, and eliminate excessive user interaction. EXSYS will not easily facilitate modularity. It is not possible to set pointers to a group of rules or to call a rule from another rule. As the system grows in size and content and modularity becomes a necessity, it may be necessary to leave the shell environment and program the system in Prolog or Lisp for mainframe or PC application.

AREAS FOR FUTURE RESEARCH

The use of expert systems in Civil Engineering is relatively new and the areas for future research are extensive. This research effort has uncovered several gaps in the field which must be promptly addressed

One gap is in the area of expert knowledge acquisition. There is very little information available which details the process of interacting with an expert to acquire knowledge. This lack of information stems from the fact that the primary researchers in expert systems have either been experts in the application of artificial intelligence techniques or domain experts researching the applicability of expert systems to their domain. The work produced tends to concentrate to a great extent on the construction of knowledge bases and their implementation. Interaction with an expert to elicit knowledge which will be the foundation of the system is very difficult and the process is as yet, vague. A compilation of techniques used would be very helpful.

A second gap is the selection and implementation of a knowledge representation scheme. Most papers concerning the design of an expert system describe the knowledge representation scheme utilized. Very seldom does one see a detailed account of how the scheme was selected and how the designer physically fit the knowledge into the scheme. Again, such information would be beneficial.

Another area of future research stems from the capabilities of EXSYS. EXSYS can be interfaced with spreadsheet programs such as LOTUS 1,2,3. This enables construction of a system which utilizes the powerful database features of the spreadsheet and the expert system abilities of the shell. Applications in this area are extensive.

EXSYS

The intent of this section is to provide evaluative comments on EXSYS, the expert system shell utilized. To users of EXSYS, it will provide little in the way of enlightenment. To the beginner, it will provide interesting reading but will be of little value. This section is primarily intended for users who are familiar with PC based shells and are looking for evaluative comments on the less visible features of EXSYS before use or purchase.

Strengths

Forward or Backward Chaining. The newest version of EXSYS can be utilized in either the forward or backward chaining mode. This nearly doubles the set of problems for which EXSYS is suited. It also allows the designer to fit the shell to the natural configuration of the problem instead of forcing the problem into the constraints of the shell.

Multiple Modes of Certainty and Probability Combination. As was mentioned earlier, EXSYS allows the use of certainty factors in one of three modes: yes/no, 0-10, and -100 - +100. It also allows the designer to select the method of combining certainty factors in the -100 - +100 mode. Certainty factors are either averaged, combined as dependent probabilities, or combined as independent probabilities.

Automatic Rule Checker. EXSYS has a built-in consistency enforcer which can either be switched on or off during editing. The checker alerts the designer when a rule has been entered which conflicts with another rule. This alert saves valuable time and effort during early developmental runs of the system.

Merging Two Distinct Rule Bases. EXSYS will allow two independent rule bases to be merged into one rule base using the utility disk. This is a very beneficial feature for large projects where parts of the system are designed separately and tested before being submitted as part of the larger system. It allows various team members to create independent rule bases and provides quick merging of the parts.

Interfacing with LOTUS 1,2,3. PC users familiar with spreadsheets can easily see the potential of such an interfacing capability. EXSYS can be used to run and control single and multiple spreadsheet programs. The tremendous data manipulation capabilities of LOTUS 1,2,3 and the simple, yet powerful heuristic decisiveness of EXSYS open an unlimited realm of applications.

Rule/Memory Capacity. EXSYS can create approximately 700 rules on a system with only 192K of RAM. For each additional 64K of RAM, EXSYS can create an additional 700 rules. This means that a system with 640K can accommodate nearly 5000 rules. 5000 well written rules can define a very extensive problem.

Shrink/Faster. The EXSYS utility disk contains two subroutines, **Shrink** and **Faster** which allow the designer to greatly reduce the run time of his completed system. **Shrink** removes all excess storage from the rule base and **Faster** rearranges the rules so that EXSYS can process them in the quickest fashion.

Simplicity of Use. EXSYS is a very user-friendly package. The three demonstration disks and the user's manual provide concise, explicit guidance. The designer need not be familiar with any programming language. All commands are issued in simple English. The on-line help facility and menu-style command options facilitate quick ease of use.

Weaknesses

Interacting with External Programs. EXSYS does have the ability to pass multiple bits of data to an external program. It can also pass a variable to an external program and receive a value for that variable. It cannot, however, make multiple calls and receive multiple feedback within one rule. Thus, a rule which requires two or more pieces of data held in another file cannot call for both pieces of information unless it can somehow be requested using one variable.

Inability to Utilize Certainty Factors Below First Level. EXSYS only tolerates the use of certainty factors within those rules whose consequents are goal nodes. All rules which do not directly evaluate a goal cannot utilize

the selected certainty factor mode. This does not mean that certainty factors cannot be utilized at deeper levels, it only means that the system designer must devise his own scheme of assigning certainty factors to common variables and passing them to other levels to be combined or eliminated. This requires that the designer be very familiar with certainty factors and their propagation.

Inability to Call a Rule From a Rule. Those familiar with MYCIN (50) are aware of the benefits of modularity in an expert system. A rule which selects only a certain block of rules to be evaluated can greatly decrease run time, user interaction, and useless data, and enhance readability. EXSYS rules cannot be written to call other rules by number so modularity is lost. This is a disadvantage of the pure production system.

Overwhelming Explanatory Data. As was mentioned in the section on SFTYCHEF's explanatory capabilities, EXSYS often provides an overabundance of rule listings when the user queries the derivation of a particular rule's antecedent. For users who are familiar with such systems or with computers in general, this excess information is at worst a nuisance. For users in construction who are possibly reluctant to use computers, such excess information could create enough confusion to cause the system to be abandoned.

Potentials of Joint Research

As this research effort progressed, the author became increasingly aware of the necessity to follow two independent tracks of research. Extensive work was done in the domain of trench safety. Due to a lack of prior background, a greater amount of work was used to develop the skills needed to create an expert system. During the research, the author encountered many students from other departments whose research thrust was in the particular aspects of expert system development. Their domains of application were somewhat irrelevant. Instead of burdening graduate civil engineers with advanced computer design skills and severely restricting the time needed to research some aspect of construction, it might be worthwhile to attempt joint research. A member of the construction field could serve as the domain researcher and assistant knowledge engineer for another student, perhaps an industrial engineer or a computer science major, who already has some expertise in the realm of expert systems. The construction student does not need to know the intricacies of system design if his goal is to apply a new technology. By working with another student, the construction student would become well versed in expert system technology and its applications, and the knowledge base researched could be quite substantial. The result could bring benefits to both departments.

REFERENCES

1. "Artificial Intelligence." ENR, 20 March 1985, pp. 20-23.
2. Barr, A. and Feigenbaum, E. A. The Handbook of Artificial Intelligence, Vol. 2. Stanford, Ca.: Heuristic Press, 1982.
3. Bennett, J. S., and Englemore, R. S. "SACON: A Knowledge-Based Consultant for Structural Analysis." Proceedings of the Sixth International Joint Conference on Artificial Intelligence. August 1979, pp. 47-49.
4. Bennett, J. S., et al. "SACON: A Knowledge-Based Consultant for Structural Analysis." Technical Report 78-23, Stanford University Department of Computer Sciences, Heuristic Programming Project, September 1978.
5. Buchanan, B. G., and Shortliffe, E. H. Rule-Based Expert Systems. New York, New York: Addison-Wesley, 1984.
6. Buchanan, B. G.; Sutherland, G. L.; and Feigenbaum, E. A. "Heuristic DENDRAL: A Program for Generating Explanatory Hypothesis in Organic Chemistry." Machine Intelligence, Vol. 4, Edited by B. Meltzer and D. Michie. Edinburgh: Edinburgh University Press, 1969, pp. 209-254.
7. Carson, Brinton A. General Excavation Methods. New York, New York: McGraw-Hill Book Co., 1961.
8. Cass, W. Martin. Common Sense in the Common Trench. Palo Alto, Ca.: Equipment Guide-Book Company, 1979.
9. Chang, T. C., Sanjay Joshi, R. L. Kashyap, S. R. T. Kumara, and C. L. Moodie, "Expert Systems in Industrial Engineering." Technical Report, Purdue University, W. Lafayette, IN, 1985.
10. Christiano, Paul P.; Konkoly, Gina Marie; and Rehak, Daniel R. A Shallow Trench Excavation Design Expert System. Technical Report R-86-155, Carnegie Mellon University, Pittsburgh, Pa., 1986.
11. Clocksin, W. F., and Mellish, C. S. Programming in Prolog. New York, New York: Springer-Verlag, 1984.
12. Cohen, P. R., and Feigenbaum, E. A. The Handbook of Artificial Intelligence, Vol. III. Los Altos, Ca.: William Kaufmann, Inc., 1982.
13. Date, C. J. An Introduction to Data Base Systems. Vol. 1. Reading, Massachusetts: Addison-Wesley Publishing Company, Inc., 1986.

14. Davis, R., and Lenat, D. Knowledge-Based Systems in Artificial Intelligence. New York, New York: McGraw-Hill, 1980.
15. Derfler, Frank J. "An Affordable Advisor." PC Magazine, Vol. 4, Number 8, 16 April 1985, pp. 113-117.
16. Derfler, Frank J. "Expert-Ease Makes Its Own Rules." PC Magazine, Vol. 4, Number 8, 16 April 1985, pp. 119-124.
17. Duda, R., and Gashing, J.G. "Knowledge-Based Expert Systems Come of Age." BYTE - A Small Systems Journal. Vol. 6, No. 9, September 1981, pp. 238-279.
18. Dunn, Irving S.; Anderson, Loren R.; and Kiefer, Fred W. Fundamentals of Geotechnical Analysis. New York, New York: John Wiley & Sons, Inc., 1980.
19. D'Ambrosio, B. "Expert Systems - Myth or Reality?" BYTE - A Small Systems Journal. January 1985, pp. 275-282.
20. EXSYS: Expert System Development Package. Version 3.1, EXSYS, Inc., Albuquerque, NM., 1983.
21. Feld, Jacob. Construction Failure. New York, New York: John Wiley & Sons, Inc., 1968.
22. Fenves, Steven J., and Rehak, Daniel R. "Expert Systems in Civil engineering, Construction Management, and Construction Robotics." Robotics Institute, Carnegie-Mellon University, Pittsburgh, PA, 1984.
23. Forgy, C. L. The OPS-5 User's Manual. Technical Report CMU-CS-81-135, Carnegie-Mellon University, Pittsburgh, Pa., 1981.
24. Fox, M. S. "The Intelligent Management System: An Overview," Technical Report CMU-RI-TR-81-4, Intelligent Systems Laboratory, The Robotics Institute, Carnegie-Mellon University, Pittsburgh, PA, 1983.
25. Goldenberg, Janet. "Experts on Call." PC WORLD, Vol. 3, Number 9, September, 1985, pp. 192-201.
26. Hayes-Roth, Frederick; Lenat, Douglas B; and Waterman, Donald A. eds. Building Expert Systems. 1st ed., Reading, Massachusetts: Addison-Wesley Publishing Company, Inc., 1983.
27. Hearn, L.; Lange, R.; and Kearney, F. "The Use of Knowledge Engineering Teams as a Method for the Development of Expert Systems." Unpublished Report by USA-CERL, November 1986.

28. Hoadley, Anthony. Essentials of Structural Design. New York, New York: John Wiley & Sons, Inc., 1964.
29. Ibbs, C. William, Jr. "Proceedings of a Workshop for the Development of New Research Directions in Computerized Applications to Construction Engineering and Management Studies." Construction Research Series No. 19, CEE 84-17681, National Science Foundation, The University of Illinois at Urbana-Champaign, 1985.
30. INSIGHT Knowledge System User's Guide. Version 1.2, Level 5 Research, Inc., Melbourne Beach, FL., 1983.
31. Karna, Kamal N., ed. 1985 Expert systems in Government Symposium. Washington, D.C.: IEEE Computer Society Press, 1985.
32. Kearney, F.; Preparata, P.; and Shaffer, R. "Artificial Intelligence for Construction and Maintenance Activities: The Critic Expert System." Unpublished report by USA-CERL, November 1986.
33. Kostem, Celal N., and Maher, Mary L., eds. Expert Systems in Civil Engineering. New York, New York: American Society of Civil Engineers, 1986.
34. Lemley, Brad. "Artificial Expertise: Intelligent Software for Problem Solving." PC Magazine, Vol. 4, Number 8, 16 April 1985, pp. 108-112.
35. Lisborg, Niels. Principles of Structural Design. London, England: B.T. Batsford, Ltd., 1967.
36. Marshall, Gilbert. Safety Engineering. Belmont, Ca.: Wadsworth Inc., 1982.
37. Mason, George E., and Shimp, Steven C. "Interpreting and Implementing OSHA Construction Trenching and Shoring Standards." Unpublished Report, Ohio State University, 1974.
38. McDermott, J. R1: A Rule Based Configurer of Computer Systems. Technical Report CMU-CS-80-119, Carnegie-Mellon University, Pittsburgh, Pa., 1980.
39. McGartland, M.R., and Hendrickson, C.T. "Expert Systems for Construction Project Monitoring." Journal of Construction Engineering and Management. Vol. III, No. 3, September 1985, pp. 293-307.
40. Michie, D. Introductory Readings in Expert Systems. Gordon and Breach Science Publishers, 1982.

41. Nillson, N.J., Principles of Artificial Intelligence. Palo Alto, Ca.: Tioga Publishing Company, 1980.
42. Nunnally, S.W. Construction Methods and Management. Englewood Cliffs, New Jersey: Prentice-Hall Inc., 1980.
43. Parker, Harry. Simplified Design of Structural Wood. New York, New York: John Wiley & Sons, Inc., 1979.
44. Peck, Ralph B.; Hanson, Walter E.; and Thornburn, Thomas H. Foundation Engineering. 2nd ed. New York, New York: John Wiley & Sons, Inc., 1974.
45. Personal Consultant Expert System Development Tools User's Guide. Version Revision A, Texas Instruments, 1985.
46. Peurifoy, R.L. Formwork for Concrete Structures. New York, New York: McGraw-Hill Book Co., 1976.
47. Politakis, Peter G. Empirical Analysis for Expert Systems. Boston, Massachusetts: Pitman Advanced Publishing Program, 1985.
48. Rich, E. Artificial Intelligence. New York, New York: McGraw-Hill, 1983.
49. Sell, P.S. Expert Systems - A Practical Approach. New York, New York: Halstead Press, 1985.
50. Shortliffe, E. H. Computer Based Medical Consultation: MYCIN. New York, New York: American Elsevier, 1976.
51. Simons, G. L. Introducing Artificial Intelligence. Manchester, England: NCC Publications, 1984.
52. Tello, Ernie. "Raw Power for Problem Solving." PC Magazine, Vol. 4, Number 8, 16 April 1985, pp. 131-137.
53. Tello, Ernie. "Marching to a Different Drummer." PC Magazine, Vol. 4, Number 8, 16 April 1985, pp. 139-144.
54. Tello, Ernie. "The Languages of AI Research." PC Magazine, Vol. 4, Number 8, 16 April 1985, pp. 173-189.
55. Ullman, J. D. Principles of Database Systems. Rockville, MD: Computer Science Press, 1980.
56. U.S. Department of Commerce. National Bureau of Standards. BSS 121. Soil Classification for Construction Practice in Shallow Trenching. Washington, D.C.: Government Printing Office, 1980.

57. U.S. Department of Commerce. National Bureau of Standards. BSS 122, A Study of Lumber Used for Bracing Trenches in the United States. Washington, D.C.: Government Printing Office, 1980.
58. U.S. Department of Commerce. National Bureau of Standards. BSS 127, Recommended Technical Provisions for Construction Practice in Shoring and Sloping of Trenches and Excavations. Washington, D.C.: Government Printing Office, 1980.
59. U.S. Department of Commerce. National Bureau of Standards. Development of Draft Construction Safety Standards for Excavations. Vol. I, Washington, D.C.: NBSIR 83-2693, 1982.
60. U.S. Department of Defense. Army Corps of Engineers. Safety and Health Requirements Manual. (EM 385-1-1). Washington, D.C.: Government Printing Office, 1981.
61. U.S. Department of Labor. Occupational Safety and Health Administration. OSHA Safety and Health Standards, Construction Industry (29 CFR 1926/1910). Washington, D.C.: Government Printing Office, 1979.
62. U.S. Department of Labor. Occupational Safety and Health Administration. Selected Occupational Fatalities Related to Trenching and Excavation as Found in Reports of OSHA Fatality/Catastrophe Investigations. Washington, D.C.: Government Printing Office, 1985.
63. Van Melle, W.; Shortliffe, E. H.; and Buchanan, B. G. "EMYCIN: A Domain Independent System That Aids in Constructing Knowledge Based Consultation Programs," Machine Intelligence, Infotech State of the Art Report 9, no. 3, pp. 281-287, 1981.
64. "Visionaries Meet Electronically to Confer on the Future of Computing." ENR, 30 May 1985, pp. 34-44.
65. Weiss, S. M., and Kulikowski, C. A. "Expert Consultation Systems: The EXPERT and CASNET Projects." Machine Intelligence, Infotech State of the Art Report 9, no. 3, 1981.
66. Winston, P. H. Artificial Intelligence. Reading, Ma.: Addison-Wesley Publishing Co., 1977.
67. Winston, P. H., and Horn, B. K. S. LISP. 2nd ed. Reading, Mass.: Addison Wesley Publishing Co., 1984.
68. Workshop on Principles of Knowledge-Based Systems. Silver Spring, MD: IEEE Computer Society Press, 1984.

APPENDIX I

EXPERT SYSTEMS AND THEIR APPLICATIONS

<u>SYSTEM NAME</u>	<u>DOMAIN OF APPLICATION</u>
1. AGE	Developing Expert Systems
2. AIRPLAN	Planning military air traffic movement
3. BUGGY	Identify students' basic arithmetic misconceptions
4. CADUCEUS	Diagnosis in internal medicine
5. CALLISTO	Modelling large manufacturing projects
6. CASNET	Diagnosis and therapy of glaucoma
7. CONGEN	Identify molecular structures
8. CRYSALIS	Protein crystallography
9. CUTTECH	Selects cutting tools, pass sizes, speeds and feeds that require machining expertise
10. DART	Diagnosis of computer system faults
11. DELTA	Troubleshoots diesel electrical locomotives
12. DENDRAL	Infers molecular structure from mass spectrographic data
13. DIPMETER ADVISOR	Analysis of oil well logging data
14. EMYCIN	General framework for expert systems
15. EXCAP	Generates process plans for machining of rotational components
16. EXCHECK	Logic and set theory tutor
17. FADES	Facilities planning and design system
18. GARI	Process planning
19. GENESIS	Planning gene splicing experiments
20. GPS	The general problem solver
21. GUIDON	Diagnostic problem solving
22. HEADMED	Psychopharmacologic advisor
23. HEARSAY-II	Speech understanding
24. HODGKINS	Diagnostic planning for Hodgkins disease
25. HYDRO	Solving water resource problems
26. IFLAPS	Facilities layout analysis and planning system
27. IMACS	Aid manufacturing
28. IPMS	Aid project scheduling
29. ISA	Aid scheduling
30. ISIS	Production scheduling
31. ISIS-II	Scheduling of factory production
32. KAS	Acquire knowledge for expert systems
33. LDS	Making legal (product liability) decisions
34. LHASA	Laboratory synthesis planning
35. LUNAR	Answers questions about lunar data for NASA
36. MACSYMA	Symbolic computation and applied analysis
37. MATHLAB	Integration of mathematics

NO-A180 322

SFTYCHEF: A CONSULTATIVE DIAGNOSTIC EXPERT SYSTEM FOR
TRENCH EXCAVATION S (U) PENNSYLVANIA STATE UNIV
UNIVERSITY PARK DEPT OF CIVIL ENGINEE. T C NICHOLAS

3/3

UNCLASSIFIED

30 MAR 87 N00228-85-G-3278

F/G 11/12

ML

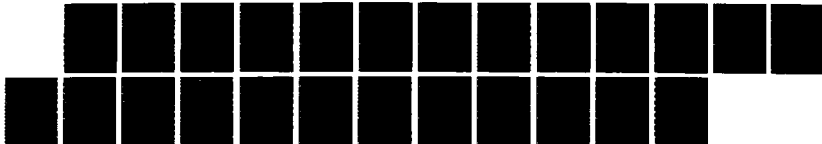

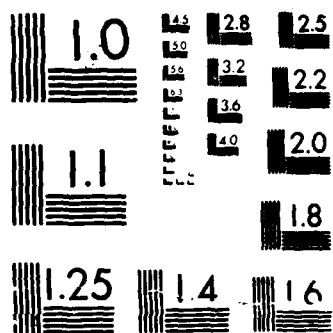

MICROCOPY RESOLUTION TEST CHART
NATIONAL BUREAU OF STANDARDS-1963-A

38. MYCIN	Consultative advice on diagnosis and therapy for infectious diseases
39. ONCOCIN	Treatment of oncology out patients
40. PIP	Kidney disease
41. PROSPECTOR	Finding ore deposits from geological data
42. PUFF	Pulmonary problems
43. PWA-PLANNER	Prototype generative assembly planning package for printed wiring board assemblies
44. QA3	Question and answering systems
45. R1	Vax system configuration
46. SACON	Assisting in structural engineering
47. SAINT	Symbolic pattern matching
48. SCHOLAR	Geography tutor
49. SECOFOR	Advising on drilling
50. SECS	Chemical analysis
51. SIR	Question and answering system
52. SIPP	Generative process planning of machined parts
53. SOPHIE	Electronics laboratory instructor
54. SPEAR	Analyzing computer error logs
55. SPERIL	Structural damage assessment
56. SYNCHER	Laboratory synthesis of known substances
57. TATR	Tactical air targeteering
58. TEIRESIAS	Acquires, corrects, and uses knowledge for MYCIN
59. TOM	Produces detailed machining plans
60. VM	Intensive care monitor
61. WAVES	Advise on seismic data analysis
62. WEST	Guided discovery learning
63. WHEAT COUNSELOR	Advising on the control of disease in winter wheat crops
63. WHY	Tutors students in the causes of rainfall
64. WUMPUS	Logic, probability, decision theory, and geometry
65. XCON	Configuring and checking orders for VAX computers
66. XPRES	Aids refining of organization procedures
67. XSITE	Configuring and checking orders for VAX computers
68. XSEL	Configuring and checking orders for VAX computers

APPENDIX II

EXPERT SYSTEM SHELLS: INFORMATIVE DATA FOR PURCHASE (25)

EXSYS

Exsys, Inc.
P.O. Box 75158, Contract Station 14
Albuquerque, NM 87194
(505)836-6674
List price: \$395, demo disk \$10, Runtime license \$600
Requirements: for "small memory" version 128K, DOS 1.10
or 2.00; for "large memory" version 192K, DOS 2.00; one
disk drive (hard disk recommended).

Comments: Exsys allows up to 400 rules with 128K and
3000 rules with 640K. It is menu-driven and designed
for non-programmers; it tolerates uncertainty and can
explain why a decision was made.

EXPERT-EASE

Human Edge Software Corp.
2445 Faber Pl.
Palo Alto, CA 94303
(415)493-1593
Jeffrey Perrone and Assoc.
3685 17th Street
San Francisco, CA 94114
(415)431-9562
List price: \$695
Requirements: 128K, one disk drive (hard disk
recommended).

Comments: Developed by Donald Michie, director of
Scotland's Turing Institute, Exper-Ease is an outgrowth
of Michie's quest to automate the knowledge-engineering
process. Unlike most other shells, Exper-Ease works by
induction, extracting rules from examples the system
builder enters. It is menu-driven and easy for
beginners to use but limited in application. (For
example, it does not allow certainty factors.) Expert-
Ease runs under the UCSD p-System and comes with a p-
System utility for formatting data disks.

INSIGHT 2

Level Five Research Inc.
4980 S. Hwy. A1A
Melbourne Beach, FL 32951
(305)729-9046

List price: \$495
Requirements: 128K (256K recommended), DOS 2.00, one disk drive.

Comments: An expanded, upgraded version of Insight, Insight 2 has a Pascal interface that can manipulate data files in dBASE II. Both versions use a proprietary language called PRL (Production Rule Language) to formulate expert rules, which can then be applied through simple menus. Maximum rule base in both versions is 615 rules with 128K, 1800 rules with 256K, with certainty factors allowed.

KDS

KDS Corp.
932 Hunter Road
Wilmette, IL 60091
(312)251-2621

List price: Development System \$795, Playback Module (for users of prefabricated applications) \$495.
Requirements: playback mode 192K, development mode 256K, DOS 2.00, two disk drives (hard disk recommended).

Comments: Written in assembly language, KDS allowa for an exceptionally large rule base-up to 16,000 rules per knowledge module. Menu-driven, it lets you enter rules in conversational English and guides you through the process of distinguishing on IF...THEN instance from another. It performs forward or backward chaining and can drive external programs in DOS.

KNOWLEDGE ENGINEERING SYSTEM

(KES)
Software Architecture and Engineering, Inc.
1500 Wilson Blvd. #800
Arlington, VA 22209
(703)276-7910

List price: \$4000
Requirements: IBM PC XT or AT with 512K (640K preferred) and 8087 math coprocessor.

Comments: This rule-based, backward-chaining program can write knowledge bases that exceed available RAM, thus supporting relatively large prototype systems. A subset of the program, Micro-PS, is faster and can run with 128K.

M.1

Teknowledge Inc.
525 University Ave.
Palo Alto, CA 94301
(415)327-6600

List price: \$10,000, recommended training \$2500, M.1a \$2000.

Requirements: 192K, DOS 2.00, two disk drives.

Comments: Oriented toward programmers, M.1 is among the more powerful, flexible tools for creating small applications. It typically forms a maximum of about 200 backward-chaining rules using a dBASE-like command language. M.1 allows certainty factors and can show how decisions were made. Interface utilities can link M.1 to external software or data bases or to information-gathering devices via an RS-232C port. M.1a, an evaluation package for nonprogrammers, can be used to create rudimentary applications.

MICRO-EXPERT

McGraw-Hill Book Co.
Professional and Reference Division
1221 Avenue of the Americas
New York, NY 10020
(212)512-2000

List price: \$49.95

Requirements: 128K, DOS 2.00

Comments: Micro Expert uses rules, which can be written with any standard word processor, to produce small, functioning expert systems that will tolerate uncertainty. A sample program included in the package deduces tree species from leaf types.

PERSONAL CONSULTANT

Texas Instruments, Inc.
Data Systems Group
P.O. Box 809063
Dallas, TX 75380
(800)527-3500

List price: \$3000, product training course \$1500.

Requirements: 512K, DOS 2.10, 10MB hard disk.

Comments: This menu-driven development tool allows up to 400 rules, created through question-and-answer interaction. A built-in IQLISP module lets programmers link a system to standard DOS business software. Personal Consultant allows certainty factors and answers queries about its reasoning.

RULEMASTER

Radian Corp.
8501 Mo-Pac Blvd.
P.O. Box 9948
Austin, TX 78766
(512)454-4797

List price: for PC or XT version \$5000, for AT version \$15,000.

Requirements: 256K; with PC XT, DOS 3.00 or PC/IX; with PC AT or compatible, DOS 3.00, PC/IX, or Xenix; with PC, two disk drives.

Comments: This menu-driven tool lets nonprogrammers create rules from examples; advanced user can write rules from scratch using Radial, RuleMaster's proprietary development language. RuleMaster allows both backward- and forward-chaining inference. Systems will explain reasoning on demand and can handle uncertainty. RuleMaster accepts input from sensory devices, data bases, or any language running under UNIX- including FORTRAN, Pascal, C, LISP, or PROLOG.

TIMM-PC (The Intelligent Machine Model)

General Research Corp.
7655 Old Springhouse Rd.
McLean, VA 22102
(703)893-5915

List price: \$9500 including training (additional licenses available at a discount).

Requirements: 640K, 10MB hard disk, 8087 math coprocessor (80287 math coprocessor with PC AT).

Comments: Originally designed for minicomputers and mainframes, TIMM-PC guides non-programmers through question-and-answer sessions that elicit examples and information. From these, TIMM-PC deduces rules that a developer can modify until the system works properly. TIMM-PC handles uncertainty and can define unfamiliar terms. It allows 90 rules per expert system in the primary knowledge base, and can link any number of expert systems together, provided that their cumulative knowledge base does not exceed 500 rules.

APPENDIX III

CORRESPONDENCE WITH DR. YOKEL

The Pennsylvania State University
Department of Civil Engineering
212 Sackett Building
University Park, PA 16802

Mr. Felix Y. Yokel
U.S. Department of Commerce
National Bureau of Standards
National Engineering Laboratory
Center for Building Technology
Geotechnical Engineering Group
Structures Division
Washington, D.C. 20234

Dear Mr. Yokel:

My name is Tom Nicholas and I am a Lieutenant in the Navy's Civil Engineer Corps. Currently, I am doing graduate research at the Pennsylvania State University in Civil Engineering, Construction. The topic of my work is the development of a prototype Knowledge Base Expert System for Trench Safety Analysis. In essence, such a system is a micro-computer system which will ask questions of a contractor and then provide him with a soils analysis, shoring design, timber selection, and a list of safety features to comply with OSHA 1926 Subpart P.

A great deal of my system is based on a study you headed for NBS and the resultant publications:

- 1.) NBS BSS 121; Soil Classification for Construction Practice in Shallow Trenching
- 2.) NBS BSS 122; A Study of Lumber Used for Bracing Trenches in the United States
- 3.) NBS BSS 127; Recommended Technical Provisions for Construction Practice in Shoring and Sloping of Trenches and Excavations
- 4.) NBS/NIOSH; Development of Draft Construction Safety Standards for Excavations

The purpose of my writing is that I have encountered a problem which neither I nor any of the faculty here have been able to resolve. I was hoping you might spend some time reviewing the following pages and annotating any incorrect assumptions/calculations I have made so that I might continue on with my research.

The problem is in the calculation of bending stress, shear

stress, and deflection for timber members of a trench shoring system. The expert system currently prompts the user for information and does a soils analysis based on the MATRIX Classification System. It then assigns a lateral weight coefficient (W_e) to the soil class. Further prompting of the user allows the system to do a table look-up on either OSHA 1926 Table P-2 or NBS BSS 127 Table A.2/A.3 to get the recommended sheeting, wale, and strut dimensions and spacing. It then places this design structure against a soil wall with the given W_e and computes $f(v)$, $f(b)$, and E , so that a proper timber selection can be made. The problem is that the calculations all lead to stresses much greater than any common lumber can withstand.

The following pages of derivation and sample calculations should shed further light. Thank you so much for your prompt consideration.

Very respectfully,

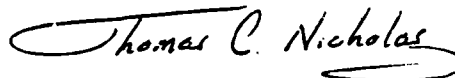

Thomas C. Nicholas
LT, CEC, USN

Copy to:

Dr. J.H. Willenbrock

SUMMARY OF MY UNDERSTANDING OF YOUR DEVELOPMENT
OF (We)

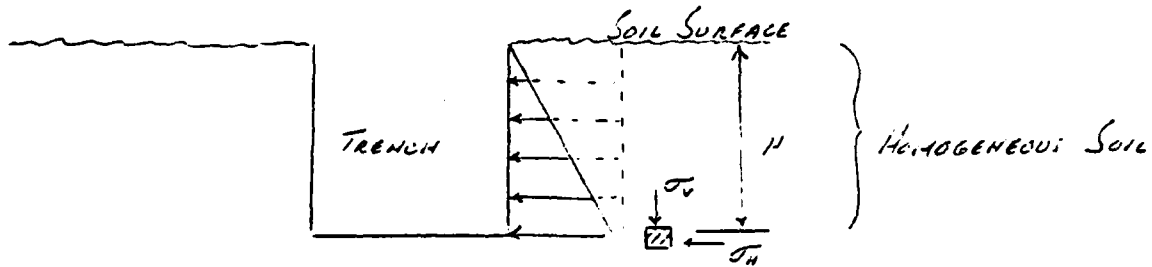

$$P_{max} = \sigma_v = \gamma H$$

$$\sigma_h = K_a \sigma_v ; K_a = \frac{\sin^2(\alpha + \bar{\phi})}{\sin^2 \alpha \sin(\alpha - \delta) \left[1 + \sqrt{\frac{\sin(\bar{\phi} + \delta) \sin(\bar{\phi} - i)}{\sin(\alpha - \delta) \sin(\alpha + i)}} \right]}$$

$K_a \Rightarrow$ Based on Coulomb's analysis.

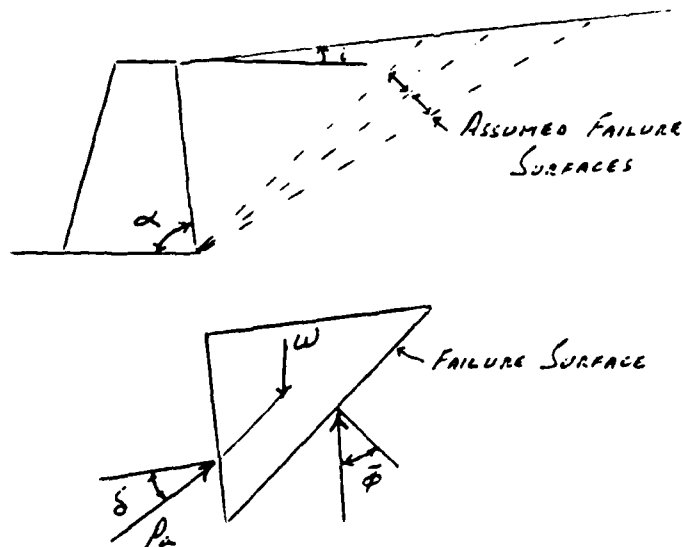

Fundamentals of
Geotechnical analysis
by Dean, Anderson, Kiefner
p. 212.

The calculation of $\bar{\phi}$, friction angle of the soil, requires a laboratory analysis and is generally not a practical item when the excavation is of short duration.

Peck, Hanson, and Thornburn recognized this and in their text *Foundation Engineering*, pages 424 and 425, they present empirical charts for estimating backfill pressure against a retaining wall based on slope angle i , and a coefficient K_v or K_H which has units of $\frac{lb}{ft^2}$ per l.a. ft.

$$\frac{\text{FORCE}}{\text{UNIT LENGTH OF TRENCH WALL}} = \frac{1}{2} (K_a \gamma H) H = \frac{K_a \gamma H^2}{2} = \frac{1}{2} K_H H^2$$

$$\therefore \{ K_H = K_a \gamma \}$$

It is my assumption that the lateral weight coefficient W_e which you have provided, is equivalent to Peck's K_H , for some average value of the slope angle.

$$\text{If so, } K_H = W_e \text{ and } \frac{F}{L} = \frac{1}{2} W_e H^2$$

Accounting for Non-homogeneous soils,

$$\frac{F}{L} \cong W_e H^2 \} \text{ i.e. a square pressure diagram}$$

Accounting for surcharge

$$\frac{F}{L} = W_e H (H+2)$$

\therefore Pressure against the open face of the trench

$$P = \frac{F}{L(H)} = W_e (H+2) \frac{lb}{ft^2}$$

22-141 50 SHEETS
 22-142 100 SHEETS
 22-144 200 SHEETS
 AMPCO

SUMMARY OF STRUCTURAL EQUATIONS
USED FOR TIMBER SELECTION

UNIFORM DISTRIBUTED LOAD
 w (lb/ft)

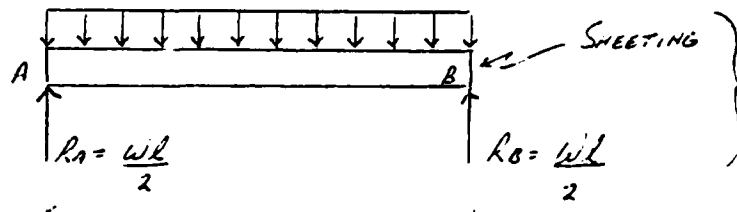

Support conditions are assumed to be single span because this assumption provides maximum bending shear, and deflection, and a contractor might use this support condition.

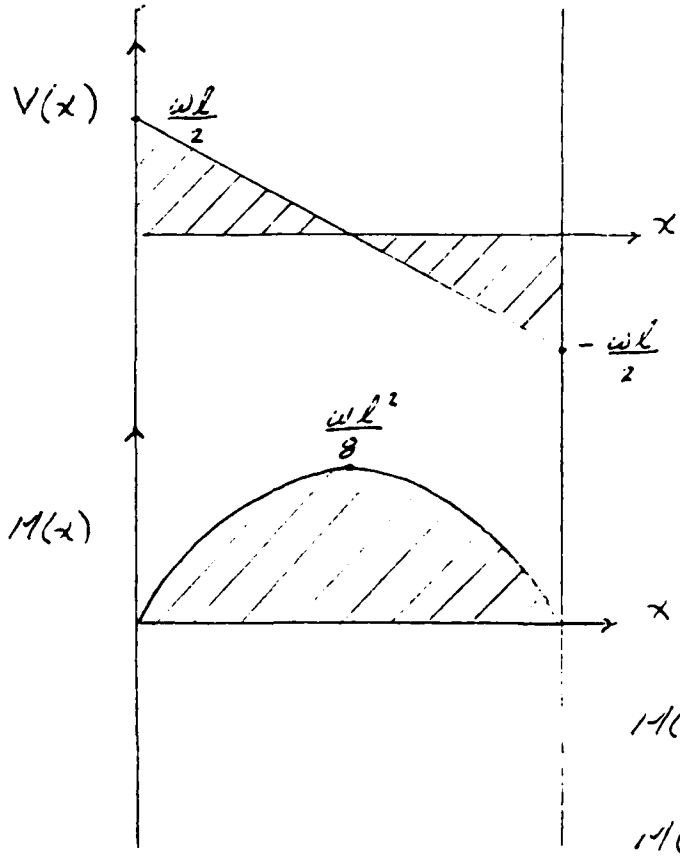

$$V(x) = - \int w dx = -wx + C$$

$$V(0) = \frac{wl}{2} = C$$

$$V(x) = \frac{wl}{2} - wx$$

$$M(x) = \int V dx = \int \left(\frac{wl}{2} - wx \right) dx$$

$$M(x) = \frac{wlx}{2} - \frac{wx^2}{2} + C$$

$$M(0) = 0 = C$$

$$M(x) = \frac{wlx}{2} - \frac{wx^2}{2}$$

MAXIMUM MOMENT

$$V = 0 \Rightarrow V\left(\frac{l}{2}\right)$$

$$M\left(\frac{l}{2}\right) = \frac{wl^2}{4} - \frac{wl^2}{8} = \frac{wl^2}{8}$$

Converting l to $\frac{lb}{12}$

$$M\left(\frac{l}{2}\right) = \frac{wl^2}{8(12)} = \frac{wl^2}{96} = \frac{wl^2}{6(16)}$$

22-141 50 SHEETS
22-142 100 SHEETS
22-144 200 SHEETS
AMERICAN

BENDING MOMENT CHECK

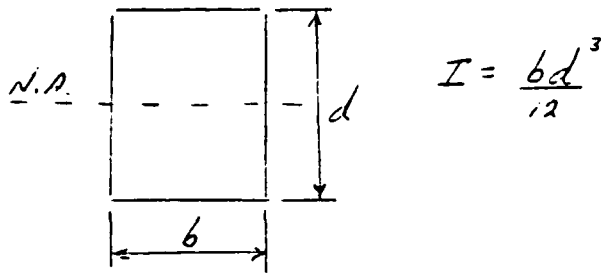

BENDING STRESS, $f_b = \frac{Mc}{I}$

SECTION MODULUS, $S = \frac{I}{c} = \frac{I}{\left(\frac{d}{2}\right)} = \frac{bd^3}{12\left(\frac{d}{2}\right)} = \frac{bd^2}{6}$

$f_b = \frac{M}{S} = \frac{6M}{bd^2}$

$M = \frac{wl^2}{6(16)}$ } from previous page

$\therefore \left\{ f_b = \frac{6wl^2}{6(16)bd^2} = \frac{wl^2}{16bd^2} \right\}$

NOTE: This is more commonly seen in the form

$\left\{ l = 4.0d \left(f_b \frac{b}{w} \right)^{1/2} \right\}$

HORIZONTAL SHEAR, F_v

For a rectangular member

$$F_v = f_v = \frac{3}{2} \frac{V}{bd} = \frac{3}{2} \frac{V}{A} ; \quad V = \text{maximum vert. shear at support}$$

$$f_v = \frac{3}{2} \left(\frac{wl}{2} \right) \frac{1}{A} = \frac{3wl}{4A} = \frac{3wl}{48A} \quad (w \text{ in } \frac{lb}{in.})$$

For Lumber $l \Rightarrow l - 2d$

Note: "Checks and shakes are present in nearly all structural lumber. Because of their presence, the upper and lower portions of a beam act partly as two beams and partly as a unit. The conservative results given by the formula for horizontal shearing stress are partly a consequence of this "two-beam" action. This fact has led to an empirical rule that permits the end shears (reactions) of a simple beam to be calculated by neglecting all loads within a distance equal to the depth of the beam from both supports."

Simplified Design of Structural Wood

by Harry Parker, John Wiley & Sons, © 1979

p. 64

$$\therefore \left\{ f_v = \frac{3w}{48A} (l-2d) = \frac{wl}{16A} \left(1 - \frac{2d}{l} \right) \right\} **$$

This is more commonly seen as

$$\left\{ l = 16.0 \frac{F_v A}{w} + 2d \right\}$$

** Same Eqn. used in "National Design Specifications for Stress-Grade Lumber and Its Fastenings," 1975 ed., Section 300-E-1, NFPA.

DEFLECTION

For a simply supported beam with continuous loading

$$\text{Defl.} = \frac{5wL^4}{4608EI} \text{ (i.n.)}$$

Using: $\Delta = \frac{L}{360}$ as a conservative assumption

$$\frac{L}{360} = \frac{5wL^4}{4608EI}$$

$$L^3 = \frac{4608EI}{5w(360)} = 2.56 \frac{EI}{w}$$

$$\left\{ L = 1.37 \left(\frac{EI}{w} \right)^{1/3} \right\} \text{ Common form}$$

$$\text{or } \left\{ E = \frac{wL^3}{2.56I} \right\}$$

SAMPLE CALCULATION I

GIVEN SOIL TYPE I $\Rightarrow Wc = 20 \frac{lb}{ft^3}$
 $H = 5-10 ft$; use 10 ft.

TABLE A.2 (NBS BSS 127)

STRUTS, 4" x 4" @ 6'-0" O.C. Horiz, 4'-0" O.C. Vert

SHEETING, 2" x 6" @ 6'-0" O.C

WALES, NONE REQUIRED

DETERMINE f_b , f_v , and E , and select a timber to use for sheeting

SOLUTION

$b = 5.5 in$ $d = 1.5 in$ $l = 48 in$ (Unsupported length)

BENDING

$f_b = \left(\frac{l}{4d} \right)^2 \frac{w}{b}$

Pressure = $Wc(H+2) = 20 \frac{lb}{ft^3} (12 ft) = 240 \frac{lb}{ft^2}$

$w = (240 \frac{lb}{ft^2})(6 ft) = 1440 \frac{lb}{ft}$

Sheeting spacing

$f_b = \left(\frac{48 in}{4(1.5 in)} \right)^2 \frac{1440 lb}{12 in ft} \frac{1}{5.5 in} = 1396 \frac{lb}{in^2} = 1396 psi$

22-141 50 SHEETS
22-142 100 SHEETS
22-144 200 SHEETS
AMR

SHEAR

$$f_v = \left(\frac{l-2d}{16} \right) \frac{w}{bd}$$

$$= \left(\frac{48.12 - 2(1.512)}{16} \right) \frac{1440 \text{ lb}}{12.12 \text{ ft} (5.512)(1.512)} = \boxed{40.91 \text{ psi}}$$

Deflection

$$E = \left(\frac{l}{1.37} \right)^3 \left(\frac{12w}{bd^3} \right)$$

$$= \left(\frac{48.12}{1.37} \right)^3 \left(\frac{12(1440 \text{ lb})}{12.12 \text{ ft} (5.512)(1.512)^3} \right)$$

$$E = \boxed{3,336,476.2 \text{ psi}}$$

TIMBER SELECTION.

Ref. NBS BSS 122 Table 4, p. 33

$$f_b = 1396 \text{ psi}$$

$$f_v = 40.91 \text{ psi}$$

$$E = 3,336,476.2 \text{ psi}$$

There is no lumber which can withstand these pressures.

NOTE. The problem becomes worse as different classes of soil, (i.e. greater w 's) are combined with deeper t . rches. Because OSHA 1926 Subpart P is still the law, table P-2 is being used by my system for dimension and spacing requirements. The problem is similar.



UNITED STATES DEPARTMENT OF COMMERCE
National Bureau of Standards
Gaithersburg, Maryland 20899

November 17, 1968

Lt. Thomas C. Nicholas
The Pennsylvania State University
Department of Civil Engineering
212 Sackett Building
University Park, PA 16802

Dear Mr. Nicholas:

I read your recent letter on your work on an expert system for shoring with interest. Recently a graduate student in Carnegie-Mellon university worked on a similar project. You may want to have a look at her work, presented in Technical Report R-86-155, "A Shallow Trench Excavation Design Expert System" by G.N. Konkoly, D.R. Rehak, and Paul, P. Christiano.

You have to realize that we deal here with several issues:

1. If we develop a new shoring system, how should it be designed in order to be reasonably adequate? For this case, our guidelines which were developed so that construction foremen can use them (ASFE told us in no uncertain terms that professional engineers refuse to get involved in bracing of shallow trenches), will give you reasonable results which are acceptable from a safety standpoint without being excessively overdesigned.

You should note, that after much discussions with the parties involved (contractors and labor unions) we settled for the simplified classification and not for the matrix. The reason for this is twofold: (1) formen could handle the simplified system well, while the matrix turned out to be too complex and required too many decisions which they are not qualified to make. (2) There is a strong preference, for reasons of efficiency, for three force levels, each twice as high as the preceding one (you can switch by merely using intermediate struts (wales will be O.K.)).

2. Are existing systems adequate? Here you are running into problems with some timber system (not hydraulic shores or trench boxes). The struts tend to check out, while the wales for larger spans tend to be unsafe. You can explain why they do not fail often. For instance few timber members will fail when subjected to 1400 psi stress (the safety factor tends to exceed 2). One of the reasons for the problem is that for larger spans contractors frequently use cages, where they double the intermediate wales by stacking two cages or more.

My own reaction to this problem is that many of these systems will go the way of the dinosaurs and they should be replaced by other systems which can be shown to be adequate. We could not in good face reduce the strength requirements just because some timber shorings cannot comply with them. Table P-2 may still be the law, but OSHA is revising their provisions and they probably will not keep this table.

As for your calculation, I have some comments. Your lateral pressure analysis on calculation page 1 is flawed, because the Coulomb equation applies to walls who can rotate at the top, and not to restrained (braced) walls. Look at Terzaghi's Theoretical Soil Mechanics and at some of Peck's papers I referenced. Your example of spaced sheeting for Class A (Type I) soil also does not apply. For these soils it is assumed that the shoring can be spaced because the soil will arch. Frequently the vertical members are omitted, and hydraulic shores resting on square plywood panels are used, spacing the support horizontally as well as vertically. The main function of the vertical member in this case is to spread the concentrated load applied by the strut. The member in this case would be more like a beam on an elastic foundation, which would generate a smaller moment at its center.

I hope that my discussion does not confuse you and I wish you luck with your project. Please do not hesitate to call if you have any further questions.

Sincerely

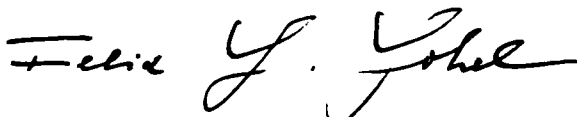

Felix Y. Yokel, Ph.D., P.E.
Senior Research Civil Engineer
Structures Division
Bdg. 226, Rm. B162

APPENDIX IV

SFTYCHEF RULES 015 - 020

RULE NUMBER: 19

IF:

- (1) The safety analysis reveals a shoring design which can be met
- and (2) The safety analysis reveals sloping criteria which can be met
- and (3) The safety analysis reveals an accounting of all miscellaneous safety features
- and (4) The safety analysis reveals an evaluation of any unusual construction activities

THEN:

- (1) SAFE - Probability=10/10
- and (2) UNSAFE - Probability=0/10

CHANGE: If <I>, Then <T>, Else <E>, Note <N>, Reference <R>, Done <ENTER>
for previous rule, for next rule:

RULE NUMBER: 16

IF:

- (1) The safety analysis reveals a shoring design that can not be met
- and (2) The safety analysis reveals sloping criteria that can not be met.
- and (3) The safety analysis reveals a failure to account for all miscellaneous safety features
- and (4) The safety analysis reveals an incomplete evaluation of any unusual construction activities

THEN:

- (1) UNSAFE - Probability=10/10
- and (2) SAFE - Probability=0/10

CHANGE: If <I>. Then <T>. Else <E>. Note <N>, Reference <R>. Done <ENTER>
for previous rule. for next rule:

RULE NUMBER: 17

IF:

(1) The safety analysis reveals a shoring design which can be met

THEN:

(1) SAFE - Probability=9/10

and (2) UNSAFE - Probability=1/10

ELSE:

(1) UNSAFE - Probability=9/10

and (2) SAFE - Probability=1/10

CHANGE: If <I>, Then <T>, Else <E>. Note <N>. Reference <R>. Done <ENTER>
for previous rule. for next rule:

RULE NUMBER: 18

IF:

(1) The safety analysis reveals sloping criteria which can be met.

THEN:

(1) SAFE - Probability=9/10
and (2) UNSAFE - Probability=1/10

ELSE:

(1) SAFE - Probability=1/10
and (2) UNSAFE - Probability=9/10

CHANGE: If <I>. Then <T>. Else <E>. Note <N>. Reference <R>. Done <ENTER>
for previous rule. for next rule:

RULE NUMBER: 19

IF:

- (1) The safety analysis reveals an accounting of all miscellaneous safety features

THEN:

- (1) SAFE - Probability=7/10
- and (2) UNSAFE - Probability=3/10

ELSE:

- (1) SAFE - Probability=3/10
- and (2) UNSAFE - Probability=7/10

CHANGE: If <I>, Then <T>, Else <E>, Note <N>, Reference <R>, Done <ENTER>
for previous rule. for next rule:

RULE NUMBER: 201

IF: (1) The safety analysis reveals an evaluation of any unusual construction activities

THEN: (1) SAFE = Probability=7/10
and (2) UNSAFE = Probability=3/10

ELSE: (1) SAFE = Probability=3/10
and (2) UNSAFE = Probability=7/10

CHANGE: If <I>, then <T>, Else <E>, Note <N>, Reference <R>, Done <ENTER>
for previous rule, for next rule:

END

6-87

DTIC