

THE ALPHA-TRACK COUNTER

ARCHIE B. TREADWELL

Library
U. S. Naval Postgraduate School
Monterey, California

THE ALPHA-TRACK COUNTER

Archie B. Treadwell

University of Chicago Press

THE ALPHA-TRACK COUNTER

* * * * *

Presented to the University of Chicago
by the author
Archie B. Treadwell

Archie B. Treadwell

UNIVERSITY OF CHICAGO PRESS
Chicago, Illinois

1957

THE ALPHA-TRACK COUNTER

by

Archie B. Treadwell

Lieutenant, United States Navy

Submitted in partial fulfillment
of the requirements
for the degree of
MASTER OF SCIENCE
IN
PHYSICS

United States Naval Postgraduate School
Monterey, California

1 9 5 5

Thesis

T 79

THE ALPHABETIC COURSE

BY

WILLIAM H. FLETCHER

LEADERSHIP IN THE CLASS ROOM

Department of Education
University of Chicago
Chicago, Illinois
1917

Order from the University of Chicago
Library, Chicago

Library
U. S. Naval Postgraduate School
Monterey, California

This work is accepted as fulfilling
the thesis requirements for the degree of

MASTER OF SCIENCE

IN

PHYSICS

from the

United States Naval Postgraduate School

THE ALPHA-TRACK COUNTER

Archie B. Treadwell

Radiation Laboratory
University of California
Berkeley, California

June, 1955

ABSTRACT

An alpha-track counter has been constructed which automatically counts and records alpha tracks on 5 by 22 cm glass photographic plates from the alpha spectrometer. The tracks, 3 by 150 microns in size, are parallel to the long dimension of the plate. The instrument scans the photographic plate in 900 strips 0.25 by 50 mm, each strip being associated with a particular energy. The number of tracks in each strip is counted and 900 points on the energy distribution curve are automatically plotted by a Speedomax recorder.

When long thin objects such as nuclear tracks are illuminated by rotating oblique dark-field illumination, they flash on and off, because light is preferentially scattered from their long dimension. The optical system of the alpha-track counter consists of a 240-power binocular microscope with a modulated dark-field illumination system that causes the tracks to flicker at a 600 cps rate. The modulation is accomplished by a polaroid filter rotating at 18,000 rpm and a stationary "analyzer" filter. A photomultiplier that has replaced one of the oculars of the microscope generates a few cycles of 600 cps voltage as a track passes under the ocular slit during a scan.

The electronic system amplifies the photomultiplier signal and discriminates against the many spurious signals produced by dust particles, scratches, random grain clumpings, and other imperfections in the emulsion. In order for a signal to pass the discriminators and be recorded, it must be of the correct amplitude and phase, and consist of the correct number of cycles.

The instrument counts about 60% of the tracks in a given strip and introduces about 100 spurious counts per strip, so that its use is limited to strips containing more than 200 tracks. Work is continuing to improve its performance.

Journal of the Royal Society of Medicine
 11, Tavistock Square, London, W.C.1

1957

ABSTRACT

The abstract section has been introduced with a view to providing a concise summary of the main points of the original papers. The abstracts are prepared by the authors and are published in the Journal of the Royal Society of Medicine. The abstracts are prepared by the authors and are published in the Journal of the Royal Society of Medicine.

When the abstracts are prepared, they are published in the Journal of the Royal Society of Medicine. The abstracts are prepared by the authors and are published in the Journal of the Royal Society of Medicine.

The abstracts are prepared by the authors and are published in the Journal of the Royal Society of Medicine. The abstracts are prepared by the authors and are published in the Journal of the Royal Society of Medicine.

The abstracts are prepared by the authors and are published in the Journal of the Royal Society of Medicine. The abstracts are prepared by the authors and are published in the Journal of the Royal Society of Medicine.

PREFACE

Since the Alpha Spectrometer was placed in operation at the University of California Radiation Laboratory, Berkeley, California, the glass photographic plates containing the spectra of alpha tracks have been evaluated by a human operator visually counting every track on the plates. Each plate may contain several million tracks, so that the counting is an extremely tedious and time-consuming operation requiring up to two months for evaluation of a single plate. As a result, the number of uncounted plates has been steadily increasing, and the need for an automatic device to aid in the counting and subsequent data reduction has become increasingly apparent.

In July of 1951 Herman P. Robinson, head of the Instrument Development and Maintenance Section of the Nuclear Chemistry Department at the Radiation Laboratory, began work to investigate the feasibility of constructing a device to count the tracks on the plates from the Alpha Spectrometer automatically. He concluded that such an instrument was practical, and conceived the fundamental principles for its operation.

This paper describes the development of a working instrument based on Robinson's ideas. The writer wishes to thank Herman P. Robinson for his help and supervision in the development of the instrument, and G. Donald Paxson of the University of California Radiation Laboratory for his aid in the design and construction of many of the electronic components. All the mechanical components of the scanning system were designed by Herman P. Robinson and fabricated by the University of California Radiation Laboratory prior to the writer's arrival at the Laboratory.

TABLE OF CONTENTS

Item	Title	Page
Abstract		ii
Preface		iii
List of Illustrations		v
Chapter I	Introduction	1
Chapter II	General Description of the Alpha-Track Counter	7
Chapter III	Design of the Scanning System	14
Chapter IV	Design of the Optical System	21
Chapter V	Design of the Electronic System	34
Chapter VI	Errors in Counting	41
Bibliography		46

LIST OF ILLUSTRATIONS

Figure	Page
1. Conventional and dark-field substage condensers	2
2. Photomicrograph of alpha tracks	4
3. Energy distribution curve and the photographic plate	8
4. Alpha-track counter, top view	9
5. Block diagram of electronic system	11
6. Scanner, top view	15
7. Scanner, end view	16
8. Transverse drive components	17
9. Microswitch and relay schematic	19
10. Light-source housing	22
11. Light-source support	23
12. The analyzer holder and dark-field adapter	26
13. Components of dark-field modulation system and scanning circuit microswitches	27
14. Air turbine and modulator	28
15. Alpha-track counter, bottom view	29
16. Polaroid modulation system and light scattering from track	30
17. Schematic of the electronic system	35
18. Normal electronic waveforms	36
19. Special electronic waveforms	37
20. Statistical grouping of tracks in the slit	42

CHAPTER I

INTRODUCTION

1. Dark-Field Illumination.

Dark-field illumination is a reversal of the usual method of lighting used in microscopy. In the conventional method the substage condenser collects light and focuses it into a spot covering the field of view of the microscope. Structure of the object viewed is revealed because its more dense portions absorb more light than the less dense portions. Nuclear tracks viewed under conventional illumination appear as dark lines on a bright background, and the random grains in the emulsion are dark specks on the same background. In dark-field illumination the random grains appear as bright specks on a black background, like stars in the sky on a dark night. The nuclear tracks appear as bright lines. To accomplish this type of illumination, the substage condenser is modified so that none of the light rays forming the circular spot illuminating the field of view can pass directly into the objective lens of the microscope. Light can enter the objective only after its path has been altered by scattering or reflection from the object viewed. Figure 1 illustrates the conventional substage and several of the most common ways of obtaining dark-field illumination. The simplest way to achieve dark-field illumination is to place a stop in front of the substage so that the central portion of the incident light is excluded from the system. The cone of light above the substage is then hollow, and the divergent rays beyond the image plane form a second inverted hollow cone. The objective of the microscope lies in the dark (or hollow) portion of the divergent cone of light, so that the only way for light to enter it is for scattering to occur in the image plane of the substage, where the object to be viewed by the microscope is placed. The paraboloid and cardioid dark-field substages accomplish the same effect by progressively more efficient optical techniques.

2. Oblique and Modulated Dark-Field Illumination.

If stops are inserted so that only a sector of the light cone above the substage is allowed to illuminate the object, the illumination is called oblique dark-field. If the object is of a nonsymmetrical nature,

THESE THINGS

THESE THINGS ARE THE SAME AS THE THINGS WHICH

are mentioned in the preceding chapter. In the present chapter we shall consider the question of the nature of the objects of the senses. It is a question which has been discussed by the philosophers of all ages. Some have held that the objects of the senses are the things themselves, and some have held that they are the images of the things. We shall now consider the question of the nature of the objects of the senses.

Let us first consider the question of the nature of the objects of the senses. We shall begin by considering the question of the nature of the objects of the sight. It is a question which has been discussed by the philosophers of all ages. Some have held that the objects of the sight are the things themselves, and some have held that they are the images of the things. We shall now consider the question of the nature of the objects of the sight.

Let us first consider the question of the nature of the objects of the sight. We shall begin by considering the question of the nature of the objects of the sight. It is a question which has been discussed by the philosophers of all ages. Some have held that the objects of the sight are the things themselves, and some have held that they are the images of the things. We shall now consider the question of the nature of the objects of the sight.

Let us first consider the question of the nature of the objects of the sight. We shall begin by considering the question of the nature of the objects of the sight. It is a question which has been discussed by the philosophers of all ages. Some have held that the objects of the sight are the things themselves, and some have held that they are the images of the things. We shall now consider the question of the nature of the objects of the sight.

Let us first consider the question of the nature of the objects of the sight. We shall begin by considering the question of the nature of the objects of the sight. It is a question which has been discussed by the philosophers of all ages. Some have held that the objects of the sight are the things themselves, and some have held that they are the images of the things. We shall now consider the question of the nature of the objects of the sight.

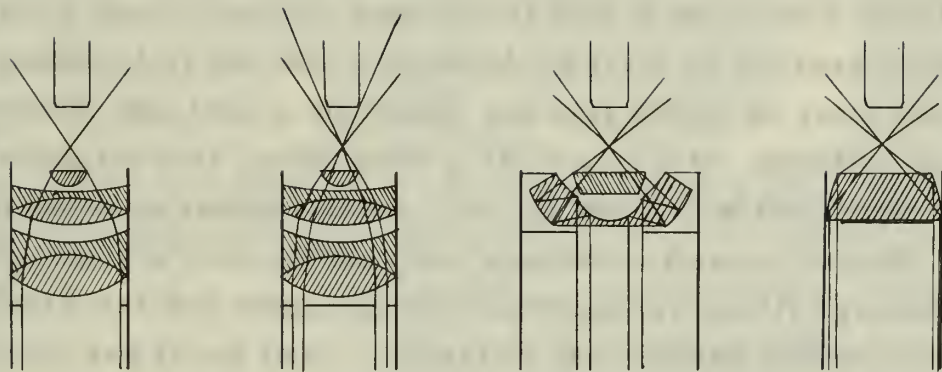

Conventional
achromatic substage
condenser

Achromatic sub-
stage with dark-
field stop

Cardioid dark-
field substage

Paraboloid dark-
field substage

MU-9861

Fig. 1 Conventional and dark-field substage condensers

its ability to scatter light into the objective is dependent upon the direction of the light incident upon it. This method was used as early as 1912 by H. Siedentopf,¹ and again by F. Weigert² in 1927, to study the nonspherical nature of submicroscopic colloidal systems. If light is preferentially scattered when incident from a given direction, it may be inferred that the particle usually has its largest dimension normal to the direction of the incident rays. When a long thin object, such as a nuclear track, is illuminated with oblique dark-field illumination utilizing incident rays perpendicular to the long dimension of the track, and viewed through a microscope of moderate power, the track is clearly visible as a bright line on a black field. If it is illuminated only by rays parallel to its long dimension, it is no longer visible, and the field remains completely dark (see Fig. 2). This effect may be explained most simply by considering that in the former case the rays are scattered by the entire length of the track as the rays strike it broadside; and that in the latter, the rays strike the track end on and are scattered only by the width of the track. If the direction of oblique illumination is slowly rotated, i. e. the position of the sector of the cone of light is rotated, the track appears to flash on and off. Most dust particles and random grain clumpings are nearly symmetrical in nature and do not flash. Therefore the rotating oblique illumination system provides a useful aid for locating stars and tracks in nuclear emulsions.³ The system employing rotating oblique illumination will be referred to as modulated dark-field illumination.

3. Design Criteria for the Alpha-Track Counter.

The alpha spectrometer^{4, 5} magnetically deflects alpha particles from a collimated beam. The amount of the deflection is a function of the energy of the particles, and is measured by allowing the deflected alphas to impinge on a photographic emulsion on a glass plate. The plate is mounted nearly parallel to the deflected beam, so that a small deflection results in a considerable spread in the tracks recorded in the emulsion on the plate. The plate is 50 mm wide by 230 mm long, with the tracks lying parallel to one another and to the long dimension (see Fig. 3). The alpha spectrometer measures the energy of particles in the 3.5- to 9.0-Mev range, but any given plate has a range of less

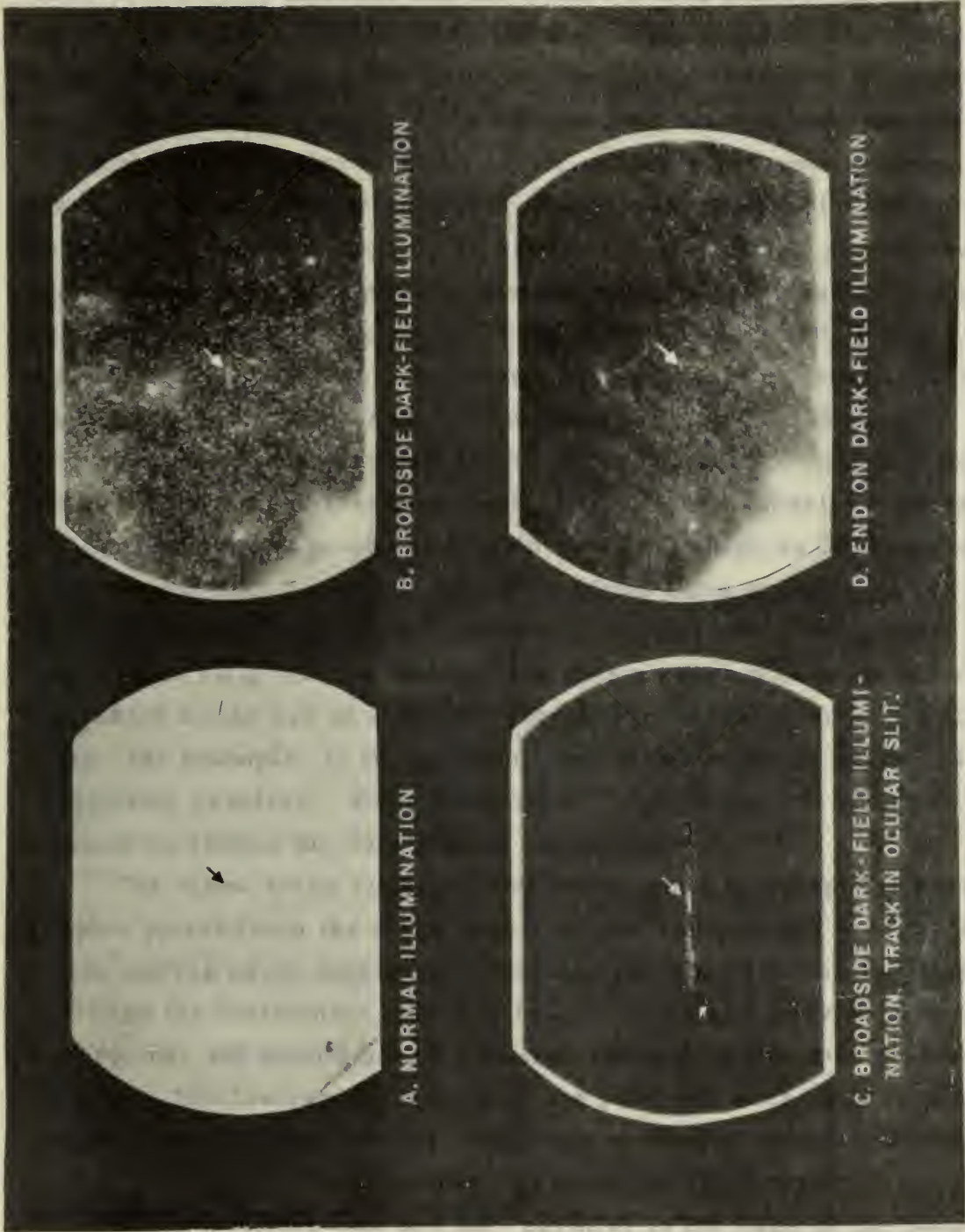

Fig. 2 Photomicrograph of alpha tracks.

ZN-1287



than 1 Mev. The size of the tracks is a function of the energy of the particles striking the emulsion, the 3.5-Mev tracks measuring approximately 0.8 by 10 microns and the 9-Mev tracks measuring approximately 0.8 by 40 microns. The position of the alpha tracks along the long dimension of the plate is a measure of the energy of the alpha particle causing the track. The information desired from the plate is a plot of the number of alpha particles of a given energy versus that energy, this plot being referred to as the energy-distribution curve of the alpha particles. In order to obtain data to plot the energy-distribution curve, the plate is divided into 900 rectangular strips spanning the width of the plate. Each strip measures 0.25 mm by 50 mm, is associated with a known energy, and contains tracks left by alpha particles of that energy. An operator, using a 500-power microscope with conventional illumination, visually counts and records the number of tracks in each strip. In high-density regions the total number of tracks in a strip may be as high as 3000, so in practice one may count only one tenth of the strip multiply by ten to obtain the total number of tracks within the strip. Also, only every tenth strip may be counted and then a rough plot made to ascertain which areas are of sufficient interest to warrant counting each strip; for example, in the neighborhood of two maxima which are not completely resolved. Even using these "short cuts," it requires about a month to reduce the data from a single plate.

The alpha-track counter must be designed to accept the photographic plates from the alpha spectrometer and plot the energy-distribution curves as an output. An operator may be required to adjust and align the instrument, place it in operation, and provide occasional monitoring, but should not be required to monitor the operation continually. The instrument must plot one point for each 0.25 mm along the length of the plate, so its output can be readily correlated with the curves already plotted manually. It must not count tracks from scattered alpha particles that are not parallel to the edge of the plate, dust particles, scratches, random grain clumpings, and any other spurious marks on the plate that would be thrown out by a human operator. Finally, it must operate as quickly as practicable, and should cut the time to count the plate at least by a factor of ten.

The instrument described in this paper meets all the requirements, and in addition retains considerable flexibility, which could make it valuable for other applications.

The instrument is designed to be used in a laboratory or field setting. It is a portable, self-contained unit that can be used to measure the concentration of a gas in a mixture. The instrument consists of a sample inlet, a flow control valve, a detector, and a readout device. The sample inlet is a simple tube that can be connected to a gas source. The flow control valve is a simple knob that can be turned to adjust the flow rate. The detector is a simple device that can be used to measure the concentration of a gas. The readout device is a simple display that can be used to read the concentration of a gas. The instrument is designed to be used in a laboratory or field setting. It is a portable, self-contained unit that can be used to measure the concentration of a gas in a mixture. The instrument consists of a sample inlet, a flow control valve, a detector, and a readout device. The sample inlet is a simple tube that can be connected to a gas source. The flow control valve is a simple knob that can be turned to adjust the flow rate. The detector is a simple device that can be used to measure the concentration of a gas. The readout device is a simple display that can be used to read the concentration of a gas.

The Operating System

The instrument is designed to be used in a laboratory or field setting. It is a portable, self-contained unit that can be used to measure the concentration of a gas in a mixture. The instrument consists of a sample inlet, a flow control valve, a detector, and a readout device. The sample inlet is a simple tube that can be connected to a gas source. The flow control valve is a simple knob that can be turned to adjust the flow rate. The detector is a simple device that can be used to measure the concentration of a gas. The readout device is a simple display that can be used to read the concentration of a gas. The instrument is designed to be used in a laboratory or field setting. It is a portable, self-contained unit that can be used to measure the concentration of a gas in a mixture. The instrument consists of a sample inlet, a flow control valve, a detector, and a readout device. The sample inlet is a simple tube that can be connected to a gas source. The flow control valve is a simple knob that can be turned to adjust the flow rate. The detector is a simple device that can be used to measure the concentration of a gas. The readout device is a simple display that can be used to read the concentration of a gas.

† The instrument is designed to be used in a laboratory or field setting. It is a portable, self-contained unit that can be used to measure the concentration of a gas in a mixture.

CHAPTER II

GENERAL DESCRIPTION OF THE ALPHA-TRACK COUNTER

1. The Scanning System.

The scanning system must move the photographic plate underneath the microscope objective in such a fashion that the objective scans the total area of the plate in 900 strips spanning the width of the plate. The scanning pattern is illustrated in Fig. 3. The scanner, which provides this pattern, is shown in Fig. 4. It resembles a lathe bed with a carriage sliding in the ways. The photographic plate is clamped in the plate holder, which is attached to the transverse stage. The transverse stage is mounted in ways on the carriage, which in turn slides in ways on the bed. Transverse motion is provided by movement of the transverse stage on the carriage, and longitudinal motion by the travelling split nut on the carriage engaging a precision lead screw mounted in the bed. The transverse stage is driven by a motor attached to the lower side of the carriage, and the lead screw by a motor mounted on the end of the bed. An arrangement of relays and microswitches provides the required scanning action.

2. The Optical System.

The optical system consists of a light source, a collimating lens, a rotating polaroid polarizer disk, a stationary polaroid analyzer disk, a specially modified substage condenser with a dark-field stop, and a binocular microscope with the conventional stage removed. When the polarizer is rotated, the track under the microscope objective is illuminated by light successively striking it broadside and end on, so that when it is viewed through the microscope it appears to flash on and off. The intensity of the light scattered into the objective is a function of the sine of the angle the polarizer makes with the analyzer. The right ocular of the microscope is left free to be used by the operator, and the left is modified to project light into a photomultiplier tube. The optics are removed from the photomultiplier ocular tube and replaced by a horizontal slit. The slit has dimensions such that it covers an area on the photographic plate of 0.25 mm by 2.5 microns and completely blocks light from all other portions of the field.*

* The slit length has temporarily been reduced to 0.125 mm to alleviate difficulties with the optical system.

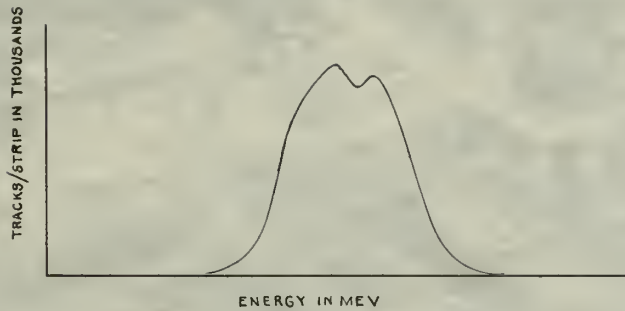

THE PHOTOGRAPHIC PLATE

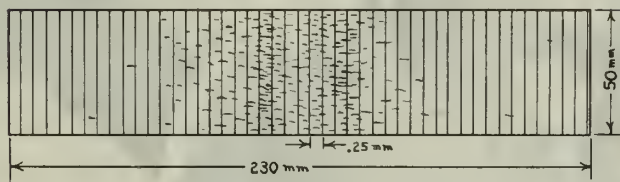

OUTSIDE DIMENSIONS OF PLATE SCALE 1 mm x 2 mm.
TRACKS & STRIPS GREATLY MAGNIFIED.

MU-9862

Fig. 3 Energy distribution curve and the photographic plate.

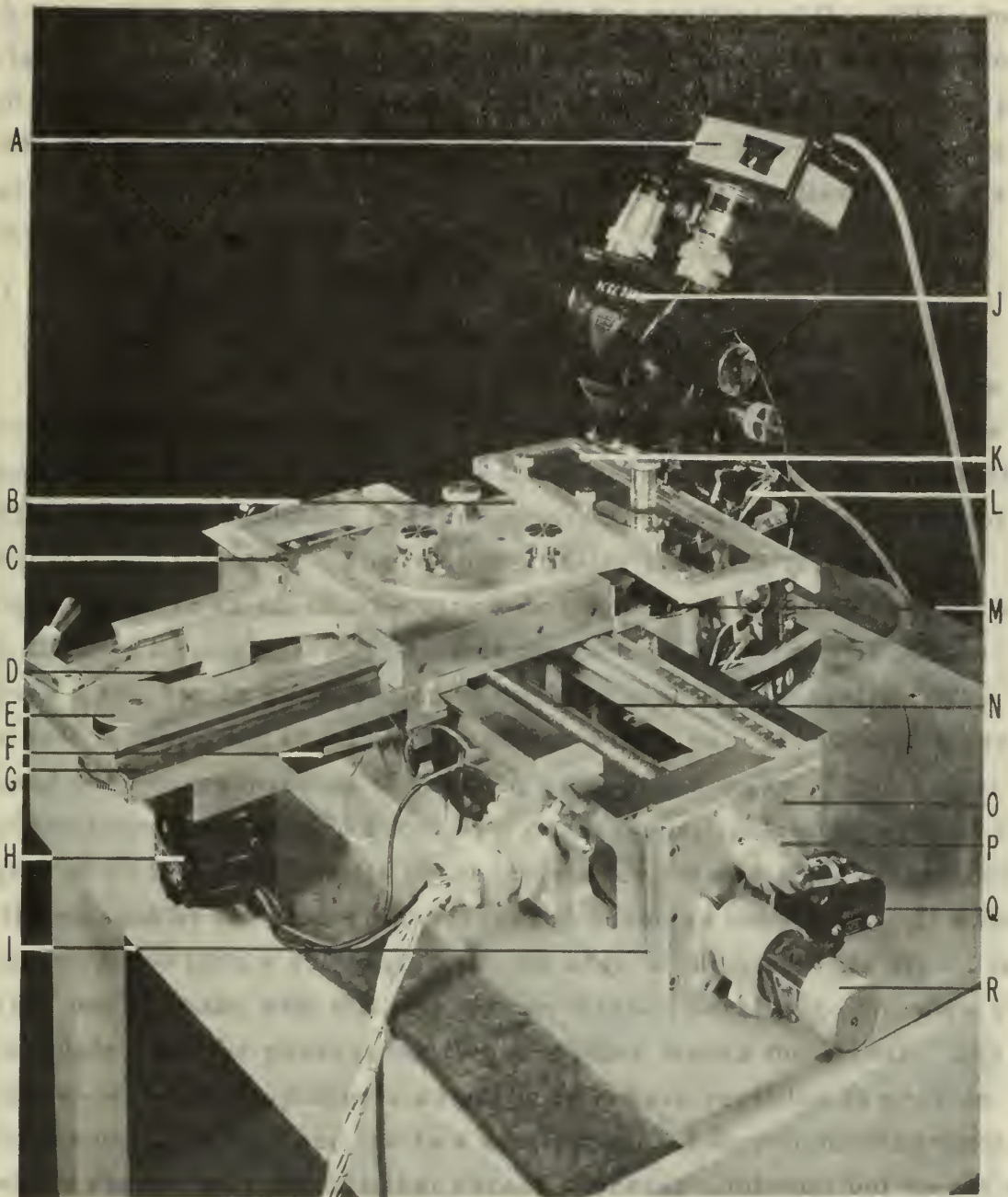

ZN-1288

Fig. 4 Alpha-track counter, top view.

- (A) Photomultiplier housing. (B) Plate holder. (C) Transverse stage. (D) Transverse drive belt. (E) Transverse drive pulley. (F) Longitudinal limit microswitch. (G) Scanner carriage. (H) Transverse motor. (I) Scanner bed. (J) Microscope. (K) Photographic plate. (L) Transverse microswitches. (M) Dark-field adapter and modulation system. (N) Lead screw. (O) Longitudinal drive gear. (P) Longitudinal cam. (Q) Longitudinal microswitches. (R) Longitudinal motor.



Fig. 1

(A) ... (B) ... (C) ... (D) ... (E) ... (F) ... (G) ... (H) ... (I) ... (J) ... (K) ... (L) ... (M) ... (N) ... (O) ... (P) ... (Q) ... (R) ... (S) ... (T) ... (U) ... (V) ... (W) ... (X) ... (Y) ... (Z) ...

A reticule in the other ocular indicates the position of the slit in the field of view. When the photographic plate is moved by the transverse plate, the slit scans across the width of the plate, covering one of the 900 strips in which the tracks must be counted. After each transverse strip is counted the carriage moves 0.25 mm longitudinally, to position the slit for scanning the next strip.

3. The Electronic System.

A block diagram of the electronic system is shown in Fig. 5.

The intensity of the light falling on the photomultiplier varies sinusoidally, with a frequency related to the angular velocity of the polarizer, whenever light from a track passes through the ocular slit. The sinusoidal variation is superimposed on an essentially constant background intensity. The photomultiplier converts this resultant light signal to an ac voltage with a dc component, providing a gain of 2×10^6 to the signal originating at the cathode. As the slit passes over a track only a few cycles of the ac signal are generated. The signal is amplified in a tuned amplifier with a gain of 500 and a narrow band pass corresponding to the frequency of the signal. The output of the tuned amplifier is gated by a phase-sensitive amplifier with a gain of 20 that receives its phase-reference voltage from a photocell illuminated by the direct light from the substage condenser. If a track makes more than a 45° angle with the edge of the plate, its signal is 180° out of phase with the signal from a track parallel to the edge of the plate, and the phase-sensitive amplifier blocks the signal. The phase-sensitive amplifier's output is full-wave rectified to provide frequency doubling, and fed to a single-channel amplitude discriminator which passes only signals that exceed a preset minimum but do not exceed a preset maximum. The output from the amplitude discriminator is a fixed rectangular pulse. The lower level of the amplitude discriminator removes noise, and the upper level discriminates against signals too strong to have been generated by a single track. The pulse train from the lower-level discriminator is fed to an integrator which produces a voltage proportional to the number of successive pulses fed to it by the minimum-amplitude discriminator. If more than two pulses in a row are missing, the integrator resets itself to zero and starts

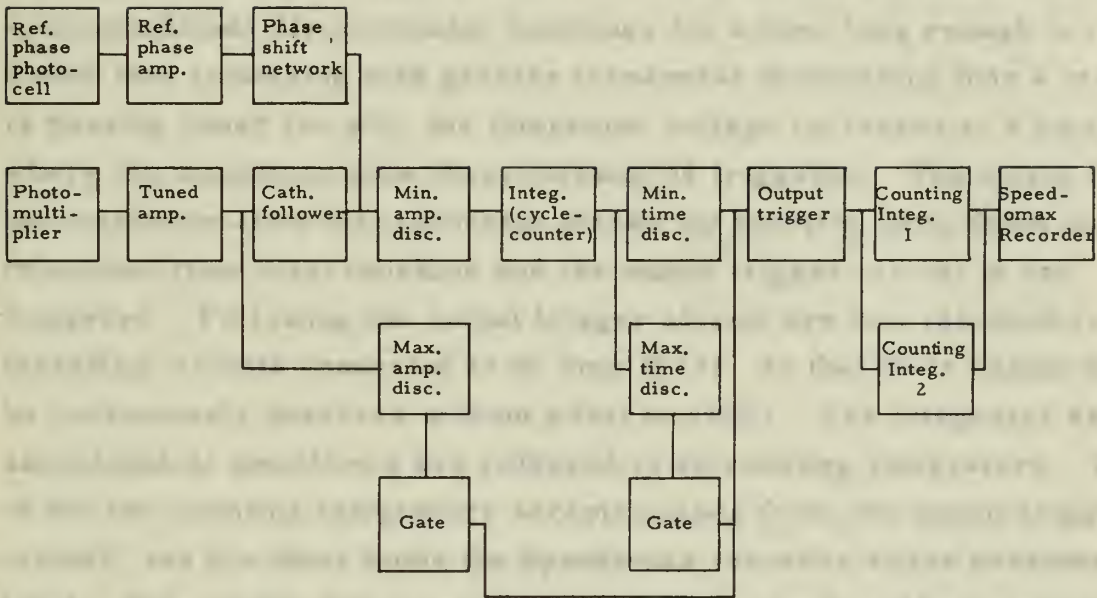

MU-9863

Fig. 5 Block diagram of electronic system.

over. Whenever the maximum-amplitude discriminator is triggered, the output pulse is blocked by a gate circuit, providing the single-channel amplitude-discriminating action. The output voltage from the integrator is fed to the minimum- and maximum-time discriminators, which are operated in parallel. When the train of pulses from the minimum-amplitude discriminator continues for a time sufficient for a track to have passed under the slit, the voltage level of the integrator rises to a level high enough to trigger the minimum-time discriminator, and a fixed rectangular negative output pulse is produced. This pulse is differentiated and the positive spike from its trailing edge is used to trigger the output trigger circuit. If the pulse train from the minimum-amplitude discriminator continues for a time long enough to indicate that something with greater transverse dimensions than a track is passing under the slit, the integrator voltage increases to a point where the maximum-time discriminator is triggered. The output from the maximum-time discriminator blanks the positive spike from the minimum-time discriminator and the output trigger circuit is not triggered. Following the output trigger circuit are two identical integrating circuits connected to dc amplifiers, so that their output may be continuously observed without adverse effect. The integrator and associated dc amplifiers are referred to as counting integrators. One of the two counting integrators accepts pulses from the output trigger circuit, and the other holds the Speedomax recorder at the previous level. The output of the counting integrators is a dc voltage proportional to the number of input pulses received, i. e. the number of tracks counted in the strip. When the slit reaches the end of a strip, the counting integrator that has been counting the tracks is connected to the Speedomax recorder by a relay actuated by a signal from the scanning system. The other counting integrator, which had been holding the Speedomax at a level proportional to the number of tracks in the previous strip, is connected to the output trigger circuit. As the slit starts to scan the next strip, the integrator connected to the output trigger circuit is reset to zero by a relay actuated by a signal from the scanning system. The paper in the Speedomax recorder is moved 1/20 inch when the Speedomax relay is closed by a signal from the

scanning system at the end of each strip, and the counting integrator resets the marking pen to a new level proportional to the number of counts in that strip. It thus requires 45 inches of recording paper to plot the energy-distribution curve from the 900 passes required to scan one complete plate.

CHAPTER III

THE DESIGN OF THE SCANNING SYSTEM

1. Requirements of the Scanning System.

The scanning system must move the photographic plate under the microscope so that the objective traverses the plate, moves 0.25 mm longitudinally, traverses the plate in the opposite direction, and moves 0.25 mm longitudinally. The cycle must be repeated 450 times in order to scan the plate completely. During this operation the plate must remain perpendicular to the optic axis of the microscope, and the movement of the plate in the direction of the optic axis of the microscope must not exceed the depth of focus of the objective. Provision must be made for adjusting the plate holder so that the axis of the strips may vary ten degrees either way from being perpendicular to the long dimension of the plate. The transverse speed of the scanning system must be such that approximately five cycles of the sinusoidally varying light scattered from the track will pass through the ocular slit of the microscope. Signals must be transmitted to the electronic circuits to switch the duty integrating amplifier, and to reset it to zero at the start of each strip.

2. Mechanical Components of the Scanning System.

The mechanical components of the scanning system are the scanning bed, the scanning carriage, the plate holder, the transverse scanning plate, the transverse motor and gears, the longitudinal motor and gears, and the base plate. Refer to Figs. 6, 7, and 8 for pictures illustrating scanner. The scanning bed is bolted to the base plate so that the plate holder is in the correct position under the microscope objective. The carriage slides longitudinally along the base plate in precision ways, and is driven by a split nut engaging a precision lead screw in the bed. The lead screw advances the carriage exactly one mm for each revolution. A cam mounted on the end of the lead screw has four teeth for actuating a microswitch so that it can be turned exactly 0.25 revolution at a time by the longitudinal motor. Transverse motion is provided by the transverse stage moving in precision ways on the carriage. The transverse motor, mounted beneath the carriage, turns a drive pulley mounted on the top of the carriage. A steel ribbon

THE DESIGN OF THE HOLOGRAM SYSTEM

1. Requirements of the Design of a Hologram

The recording system must meet the following requirements:

(1) The illumination system must be designed to provide a uniform

illumination of the entire area of the recording plate.

(2) The illumination system must be designed to provide a

uniform illumination of the entire area of the recording

plate over the entire area of the recording plate.

(3) The illumination system must be designed to provide a

uniform illumination of the entire area of the recording

plate over the entire area of the recording plate.

(4) The illumination system must be designed to provide a

uniform illumination of the entire area of the recording

plate over the entire area of the recording plate.

(5) The illumination system must be designed to provide a

uniform illumination of the entire area of the recording

plate over the entire area of the recording plate.

(6) The illumination system must be designed to provide a

uniform illumination of the entire area of the recording

2. Mechanical Components of the Recording System

The mechanical components of the recording system are the

recording plate, the recording system, the recording plate,

and the recording system. The recording plate is the

recording plate, the recording system, the recording plate,

and the recording system. The recording plate is the

recording plate, the recording system, the recording plate,

and the recording system. The recording plate is the

recording plate, the recording system, the recording plate,

and the recording system. The recording plate is the

recording plate, the recording system, the recording plate,

and the recording system. The recording plate is the

recording plate, the recording system, the recording plate,

and the recording system. The recording plate is the

recording plate, the recording system, the recording plate,

and the recording system. The recording plate is the

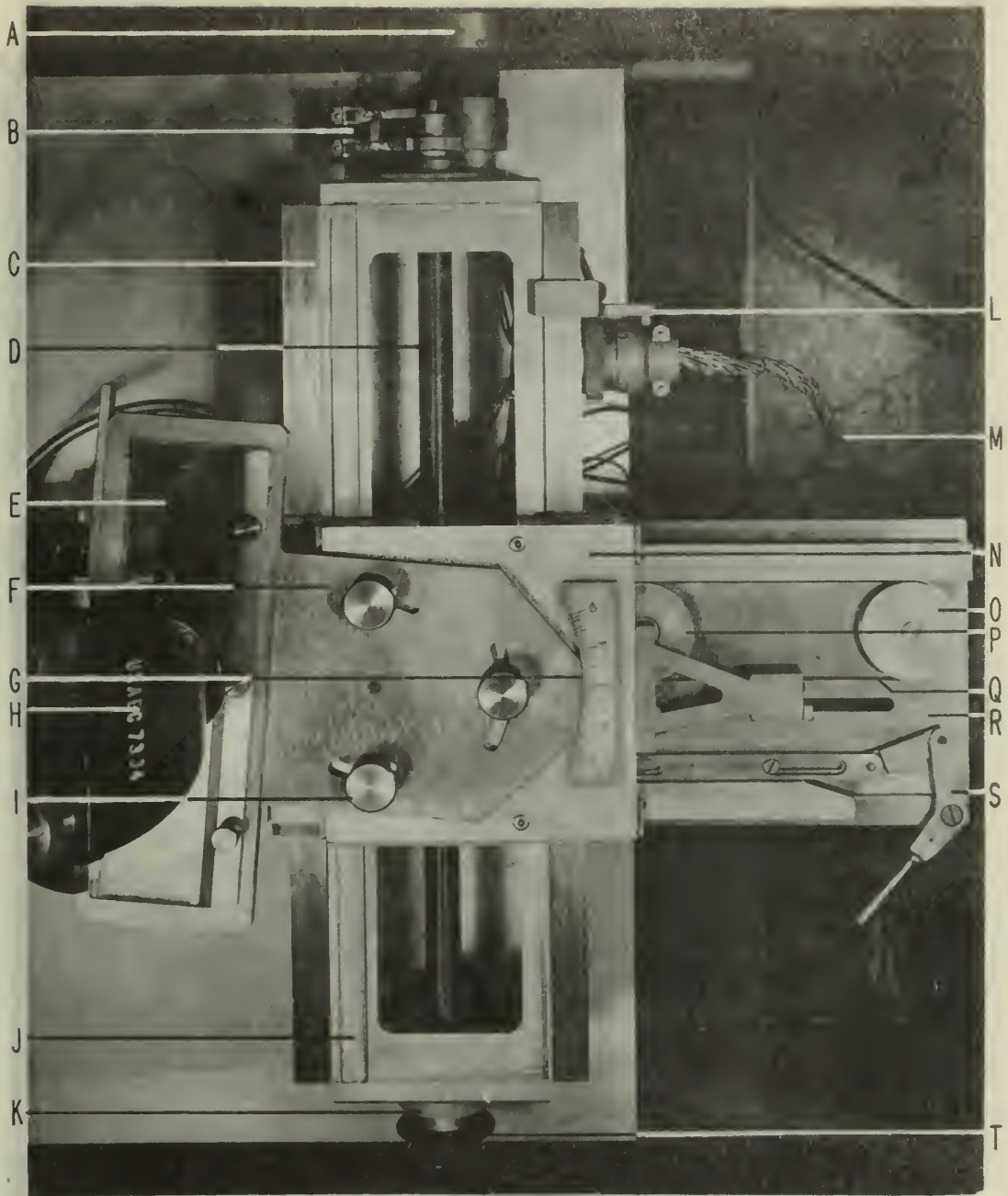

ZN-1289

Fig. 6 Scanner, top view.

(A) Longitudinal motor. (B) Longitudinal microswitches. (C) Scanner bed. (D) Lead screw. (E) Photographic plate. (F) Plate holder. (G) Tilt angle graduated scale and vernier. (H) Microscope. (I) Tilt angle locking screws. (J) Longitudinal graduated scale. (K) Longitudinal vernier. (L) Longitudinal limit stop. (M) Cable to electronic chassis. (N) Transverse stage. (O) Transverse drive pulley. (P) Transverse idler pulley. (Q) Transverse drive belt. (R) Scanner carriage. (S) Split-nut release lever. (T) Manual longitudinal drive knob.

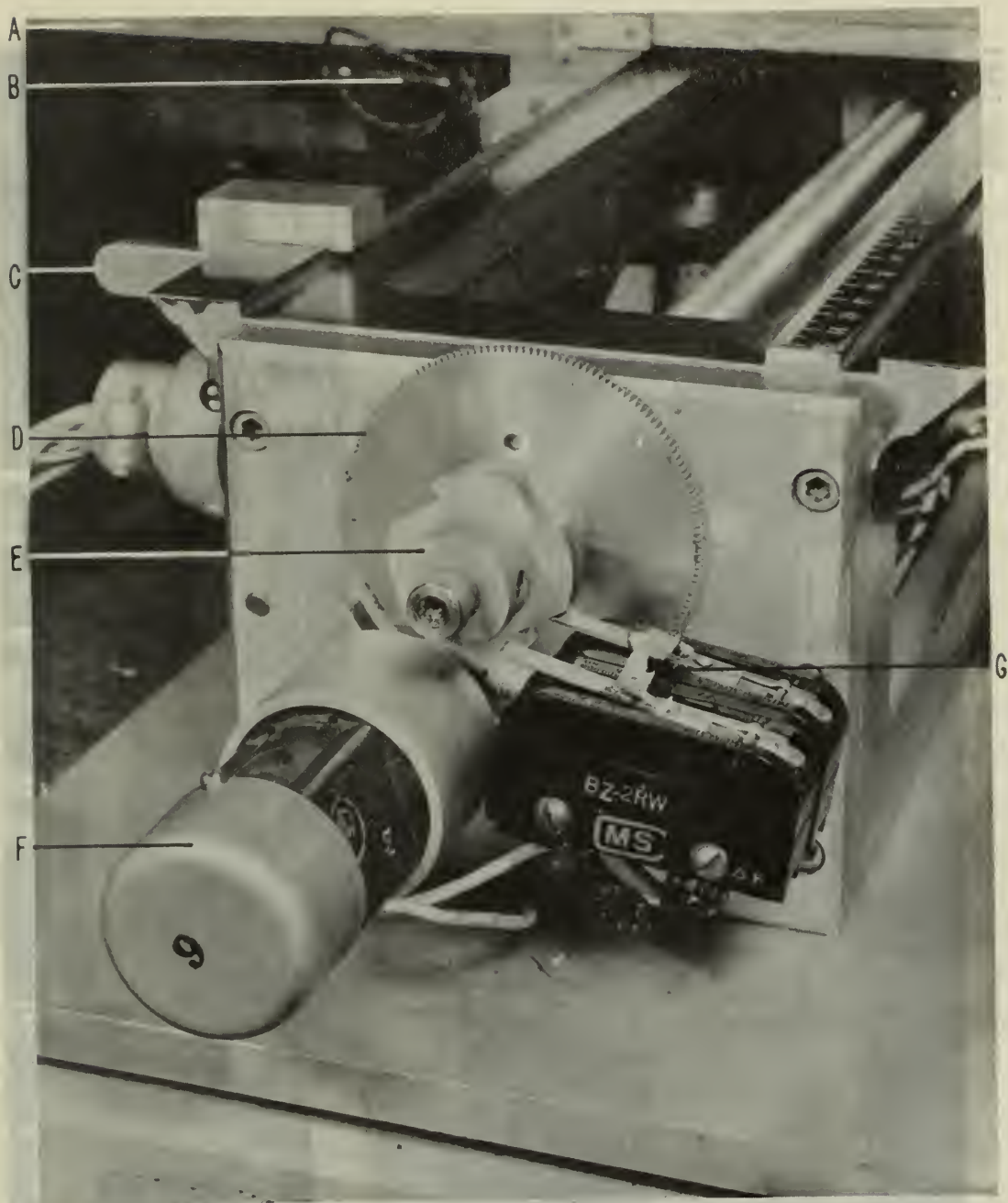

ZN-1290

Fig. 7 Scanner, end view.
(A) Scanner carriage. (B) Longitudinal limit microswitch.
(C) Longitudinal limit stop. (D) Longitudinal drive gear.
(E) Longitudinal cam. (F) Longitudinal motor. (G) Longitudinal
microswitches.

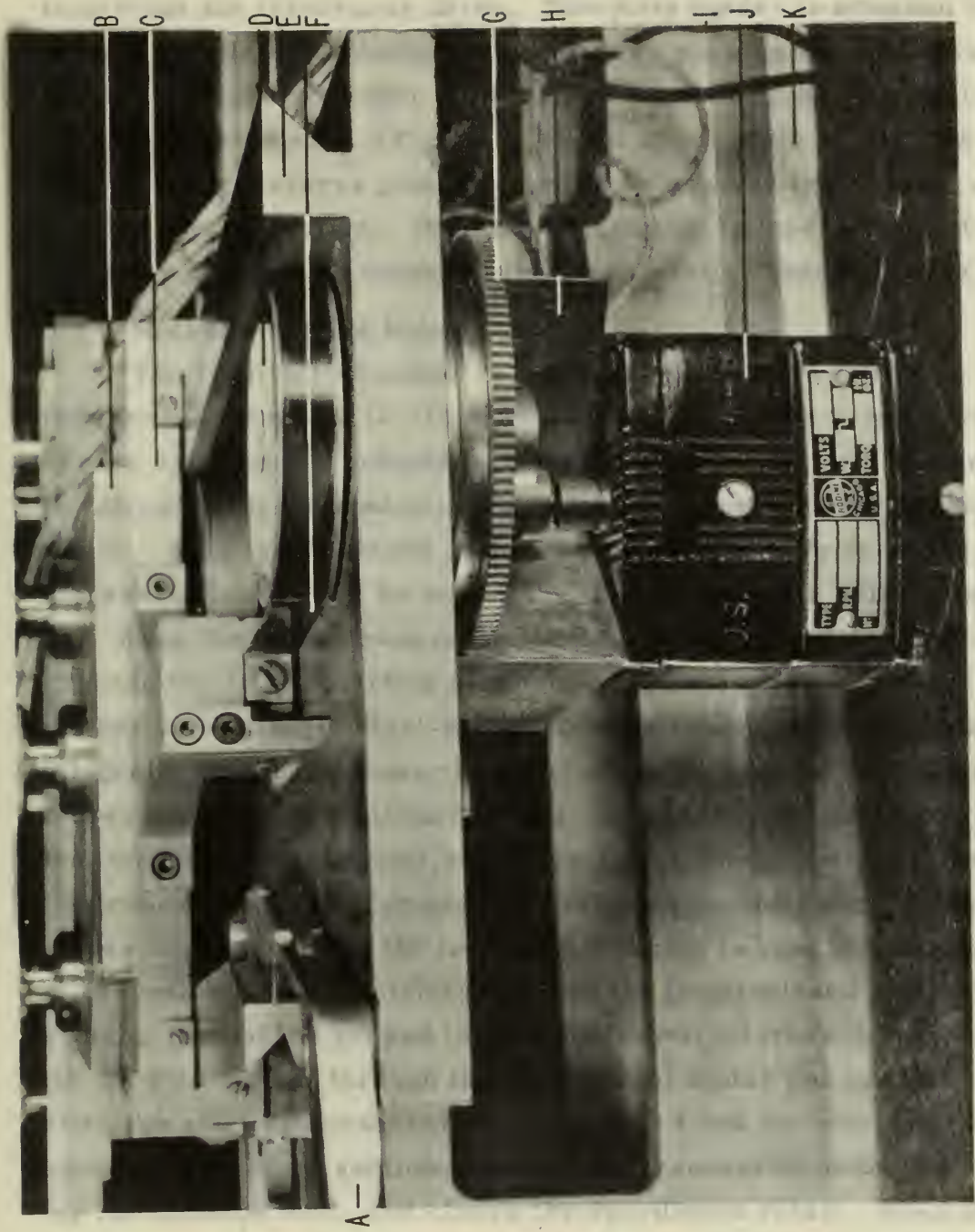

ZN-1291

Fig. 8 Transverse drive components.
 (A) Split nut release lever. (B) Plate holder. (C) Transverse plate. (D) Transverse drive pulley. (E) Scanner carriage. (F) Transverse drive belt. (G) Transverse drive gear. (H) Shim. (I) Scanner bed. (J) Transverse motor. (K) Base plate.

belt circles the drive pulley and an idler pulley. A stanchion projecting downward from the transverse plate is screwed to the steel belt to provide the transverse drive. The plate holder is attached to the transverse plate by knurled thumb screws passing through curved slots in the holder so that the required twenty degrees of angular adjustment is available. (Fig. 6). A stud on the plate holder fits into a hole in the transverse plate to provide an axle for the rotation and prevent lateral motion. Once the adjustment is made, the plate holder is firmly clamped by means of the three knurled thumb screws.

3. Microswitch and Relay Circuits.

The longitudinal motor is a series-wound 27-v dc motor, and the transverse motor is 110-v 60-cycle synchronous 2-rpm motor. Figure 9 provides a schematic drawing of the microswitches and relay circuitry associated with these motors to provide the scanning action. With the positions of the switches and relays as shown, the transverse motor will be on and the transverse plate will be moving up. When the upper transverse limit switch is actuated one section grounds the 16-mf starting condenser, allowing it to discharge through the coil of the longitudinal-motor starting relay, and ungrounds the integrator-reset condenser in the electronic chassis. The other section closes the 110-v circuit through the coils of the reversing relay and the integrator change over relay, switching integrators and reversing the transverse motor for braking. The longitudinal starting relay closes long enough for the longitudinal motor to turn the longitudinal microswitch cam sufficiently to close the longitudinal-limit microswitch. One of the ganged longitudinal-limit microswitches closes the 27-v dc circuit through the longitudinal motor and keeps it running after the starting condenser has discharged and the starting relay has opened. The other section shuts off the transverse motor by interrupting its common lead, and closes the Speedomax relay. When the lead screw has turned 0.25 revolution the longitudinal-microswitch cam opens the longitudinal microswitches. One of the microswitches shuts off the longitudinal motor, which stops almost instantly owing to the action of the 100-ohm braking resistor across its leads. The other microswitch starts the transverse motor on the downward scan. When

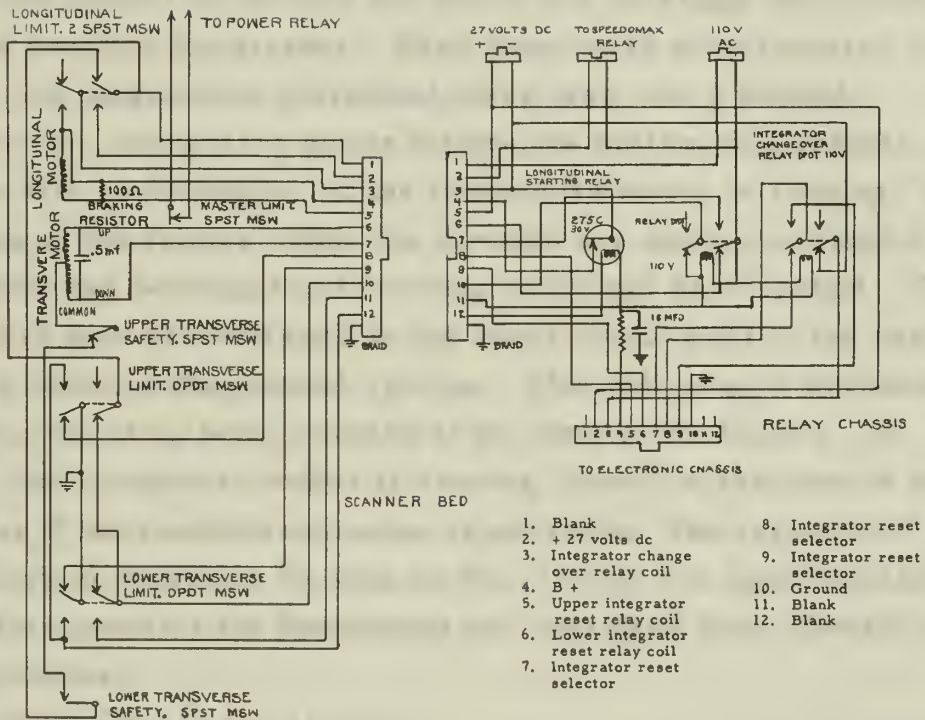

MU-9864

Fig. 9 Microswitch and relay schematic .

the upper transverse-limit microswitch is released, the starting condenser recharges and the integrator reset condenser on the electronic chassis is connected to ground, closing the integrator reset relay momentarily and thereby resetting the integrator connected to the output trigger circuit to zero. The reversing relay and the integrator change-over relay remain closed because two of the reversing relay contacts are used to make them self-locking. When the lower-limit microswitch is actuated the cycle repeats itself, with the exception that the reversing relay coil and the integrator change-over relay coil are now opened to reverse the motor and exchange the connections of the two counting integrators. Each transverse scan requires 1.5 minutes; the longitudinal movement takes less than a second.

If there is a momentary power failure the system will resume operation with no difficulty. If the transverse motor is running "up" at the time of the failure, when the circuits are again energized it will be reversed because the reversing relay will have opened. The scanner will thus proceed back to the lower limit, shift to the next strip, and continue the normal cycling. This will give an erroneous reading for the strip being counted at the time of the failure. If, however, the transverse motor is running "down" at the time of the failure, or if the longitudinal motor is operating, the system will resume normal operation as soon as the circuits are again energized. If the failure persists the Speedomax pen may drift down towards zero after several minutes.

4. Modifications to the Scanner.

The scanner transverse tracking system had been designed for much faster transverse tracking than was possible with the modulation system adopted, and some modification was therefore necessary. Provision had originally been made for a 27-v dc motor identical with the longitudinal motor. The motor bracket was removed and a new mounting and gear train were installed to accept the 2-rpm motor described in the previous section and to gear it down to the required transverse tracking rate of 30 mm per minute. Figure 8 shows the mounting and gear train for the new transverse motor.

The first step in the process of identifying a research problem is to determine the area of interest. This is often done by reviewing the literature in the field and identifying gaps in knowledge. Once a problem has been identified, the next step is to formulate a research question. This question should be specific, measurable, and researchable. It should also be significant and contribute to the existing body of knowledge in the field.

After the research question has been formulated, the next step is to conduct a literature review. This involves searching for and evaluating existing research on the topic. The purpose of the literature review is to identify what is already known about the topic and to determine what gaps in knowledge remain. This information is used to refine the research question and to develop a research plan.

The final step in the process of identifying a research problem is to develop a research plan. This plan should outline the methods that will be used to collect and analyze data, and it should also specify the timeline for the project.

4. Identification of the Problem

The first step in the process of identifying a research problem is to determine the area of interest. This is often done by reviewing the literature in the field and identifying gaps in knowledge. Once a problem has been identified, the next step is to formulate a research question. This question should be specific, measurable, and researchable. It should also be significant and contribute to the existing body of knowledge in the field.

CHAPTER IV

DESIGN OF THE OPTICAL SYSTEM

1. The Light Source.

The light source used in the instrument is a 100-watt Western Union zirconium arc. The source and housing are mounted underneath the base plate, as shown in Figs. 10, 14. Positioning of the arc is highly critical. It can be moved only 1 mm in any lateral direction and 3 mm vertically without throwing the entire optical system out of alignment. If the optical system is misaligned, a signal is continuously generated because the four quadrants of the analyzer disk are not uniformly illuminated. Provision is made in the light-source housing to provide three degrees of motion for positioning the arc. Thumb screws are furnished to allow fine adjustment, and locking nuts to secure the light firmly after it has been adjusted. The light source must be very intense, perfectly symmetrical, and of uniform intensity throughout a 0.1-inch-diameter circular area in the center. Although the zirconium arc does not quite fulfill the requirement of providing uniform intensity over a circular area 0.1 inch in diameter, its intensity is reasonably uniform over half this circular area, and it is highly superior to any other light source investigated. The reason for the stringent requirements placed on the light source are explained further in the next section. The arc tends to wander badly when it is first lighted, but after about ten minutes' operation it stabilizes so that the requirements as to lateral position are met.

Many other light sources were tried, but all failed to even approach the requirements. Many different tungsten filaments and ribbons were tried, but they failed to meet the symmetry requirements. The "Point-to-Light" tungsten source was not tried because it is quite expensive and it was felt that it would not have the required circular area. Ordinary carbon arcs were experimented with, but proved too unstable as to intensity, as well as wandering. It is possible that if the carbons were carefully dried prior to being struck, and operated at very high current density, they might prove

THE HISTORY OF THE UNITED STATES

THE HISTORY OF THE UNITED STATES

THE HISTORY OF THE UNITED STATES

THE HISTORY OF THE UNITED STATES

THE HISTORY OF THE UNITED STATES

THE HISTORY OF THE UNITED STATES

THE HISTORY OF THE UNITED STATES

THE HISTORY OF THE UNITED STATES

THE HISTORY OF THE UNITED STATES

THE HISTORY OF THE UNITED STATES

THE HISTORY OF THE UNITED STATES

THE HISTORY OF THE UNITED STATES

THE HISTORY OF THE UNITED STATES

THE HISTORY OF THE UNITED STATES

THE HISTORY OF THE UNITED STATES

THE HISTORY OF THE UNITED STATES

THE HISTORY OF THE UNITED STATES

THE HISTORY OF THE UNITED STATES

THE HISTORY OF THE UNITED STATES

THE HISTORY OF THE UNITED STATES

THE HISTORY OF THE UNITED STATES

THE HISTORY OF THE UNITED STATES

THE HISTORY OF THE UNITED STATES

THE HISTORY OF THE UNITED STATES

THE HISTORY OF THE UNITED STATES

THE HISTORY OF THE UNITED STATES

THE HISTORY OF THE UNITED STATES

THE HISTORY OF THE UNITED STATES

THE HISTORY OF THE UNITED STATES

THE HISTORY OF THE UNITED STATES

THE HISTORY OF THE UNITED STATES

THE HISTORY OF THE UNITED STATES

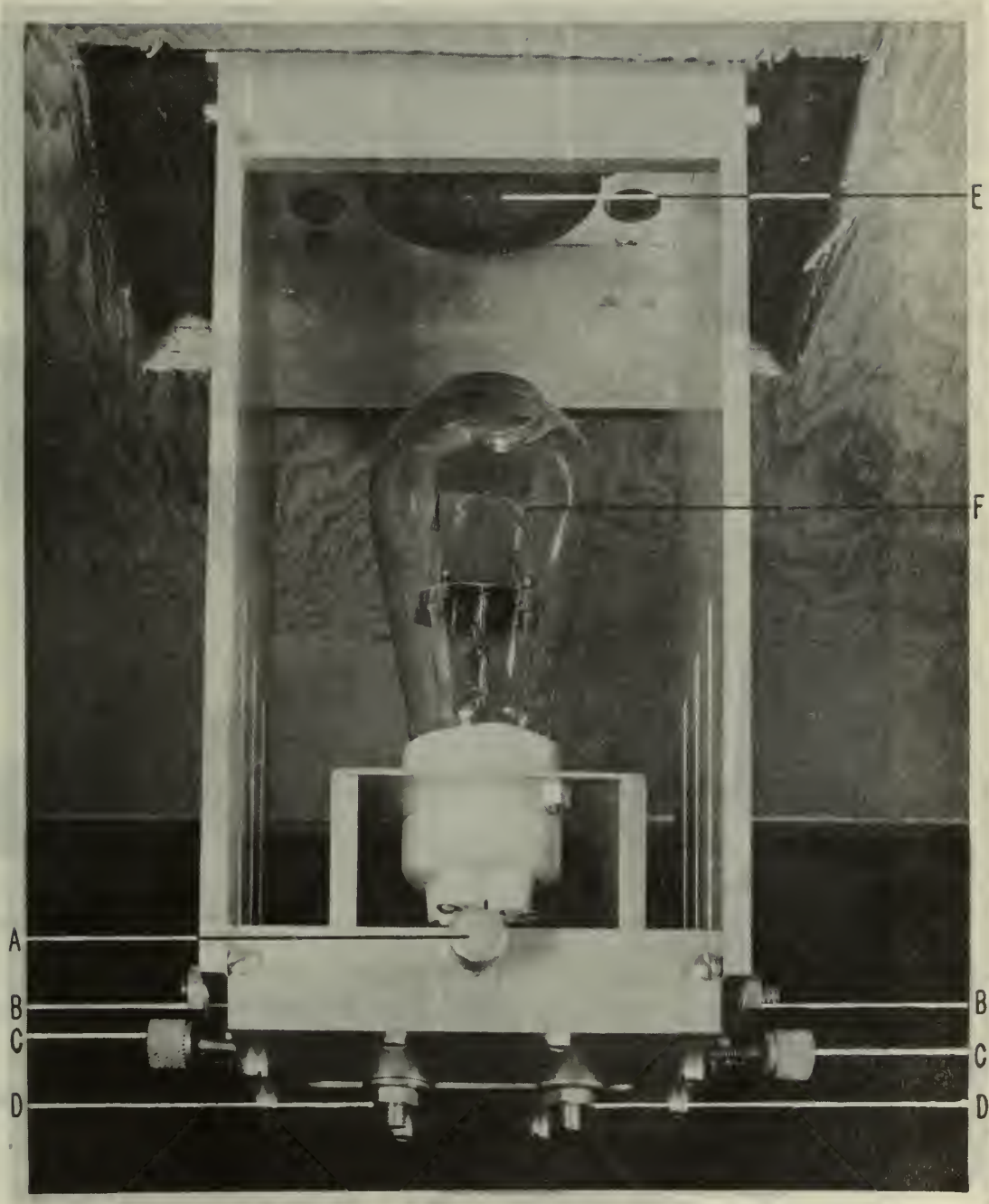

ZN-1292

Fig. 10 Light-source housing.

- (A) Transverse positioning screw.
- (B) Vertical locking screw.
- (C) Longitudinal positioning screw.
- (D) Longitudinal locking screws.
- (E) Collimating lens.
- (F) Zirconium arc.



satisfactory. Several neon and argon glow discharges were tried, but they all failed to produce the required intensity. Strangely enough, the smallest of the glow discharge bulbs tested came closest to reaching the required intensity. A 0.04-watt argon bulb was pulsed so that its average power dissipation was one watt. It provided one tenth of the necessary actinic light for several hours before sputtering darkened the envelope and diminished the intensity. The larger glow-discharge bulbs have essentially the same point intensity as the 0.04-watt one, but provide a much broader source. Since only the required circular area of the source can be utilized, it is the intensity within this area that determines the effective intensity of the source, not the total light flux or the power dissipated. This is because the substage condenser reproduces an image of the source on the photographic plate, and only that portion of the image in the area viewed by the ocular slit is useful. If the source were exactly 0.1 inch in diameter, the area on the photographic plate viewed by the ocular slit would be perfectly inscribed in the circular image of the source. The source must be of uniform intensity over the useful area or else the image of the source in the area viewed by the ocular slit will not be uniform, and the track will be more brilliantly illuminated in one part of the slit than in another. It can be shown by the zonal theory of spherical lenses that any asymmetry of the source will result in a similar asymmetrical illumination proceeding from the related zones of a spherical collimating lens. This will result in the passing of more light through one pair of quadrants in the analyzer than the other, and will therefore generate a spurious signal by uneven illumination of the background grains even though a track is not being viewed. The effect is still quite marked even though the asymmetry is well beyond the limit of the useful area of the source. This phenomenon was responsible for the failure of the tungsten ribbons.

The zirconium-arc light source is placed at the focal point of a double convex collimating lens so that collimated light is furnished the modulating system. The collimating lens mount is screwed into the base plate directly beneath the modulating system, as shown in Fig. 10.

2. The Modulation System and Substage Condenser Dark-field Adapter.

Modulation of the dark-field illumination is accomplished by means of a polaroid disk, which is rotated at 18,000 rpm by means of a compressed-air turbine. The turbine rotor is pressed into the bore of an S. K. F. ball bearing, manufacturer's number 6207 YC/C78. The ball bearing is pressed into a hollow cylindrical support which is mounted to the upper side of the base plate underneath the microscope substage condenser. The collimating lens is screwed into the base plate inside this support, allowing the collimated light to pass up the inside of the support, through the hollow turbine rotor, through the bore of the bearing, and through the rotating polaroid polarizer disk attached to the top of the bore of the bearing. This causes the plane of polarization of the collimated light to rotate with an angular velocity of 18,000 rpm. The dark-field stop and analyzer polaroid disk are attached to the bottom of the substage condenser by means of a special bracket pictured in Figs. 12 and 13. Refer to Figs. 14 and 16 for a diagram of the polarizer and analyzer. The analyzer polaroid disk is divided into four quadrants with the "grain" of the polaroid in any quadrant perpendicular to the "grain" of the polaroid in either adjacent quadrant. The polarized light proceeding up from the polarizer will be blocked by one pair of opposing quadrants when it is transmitted by the other. As the polarizer rotates and the analyzer is held stationary, the light transmitted by one pair of the analyzer quadrants varies as the sine squared of the angle the polarizer makes with any arbitrary stationary reference. The other pair of quadrants transmits light varying as the cosine squared of the polarizer angle. When one pair of quadrants is transmitting a maximum of light the other pair is transmitting no light, and vice versa. The analyzer is oriented so that the light from one pair of quadrants strikes the alpha tracks broadside and the light from the other pair of quadrants strikes them end on. This causes the light scattered into the objective by an alpha track to vary as the sine squared of the polarizer angle. The frequency of variation is twice the rotation frequency of the polarizer because the sine squared of an angle is a linear function of the cosine of twice the angle. Thus

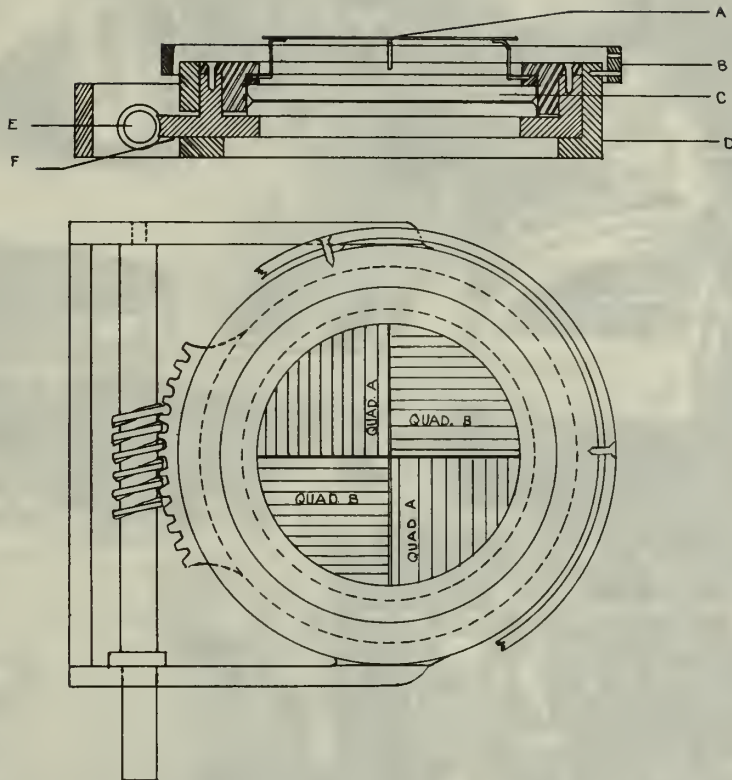

MU-9865

Fig. 12 The analyzer holder and dark-field adapter
 A. Dark-field stop
 B. Mounting bracket
 C. Analyzer polaroid disk
 D. Stationary housing
 E. Screw to align analyzer axis with track axis
 F. Gear to align analyzer axis with track axis

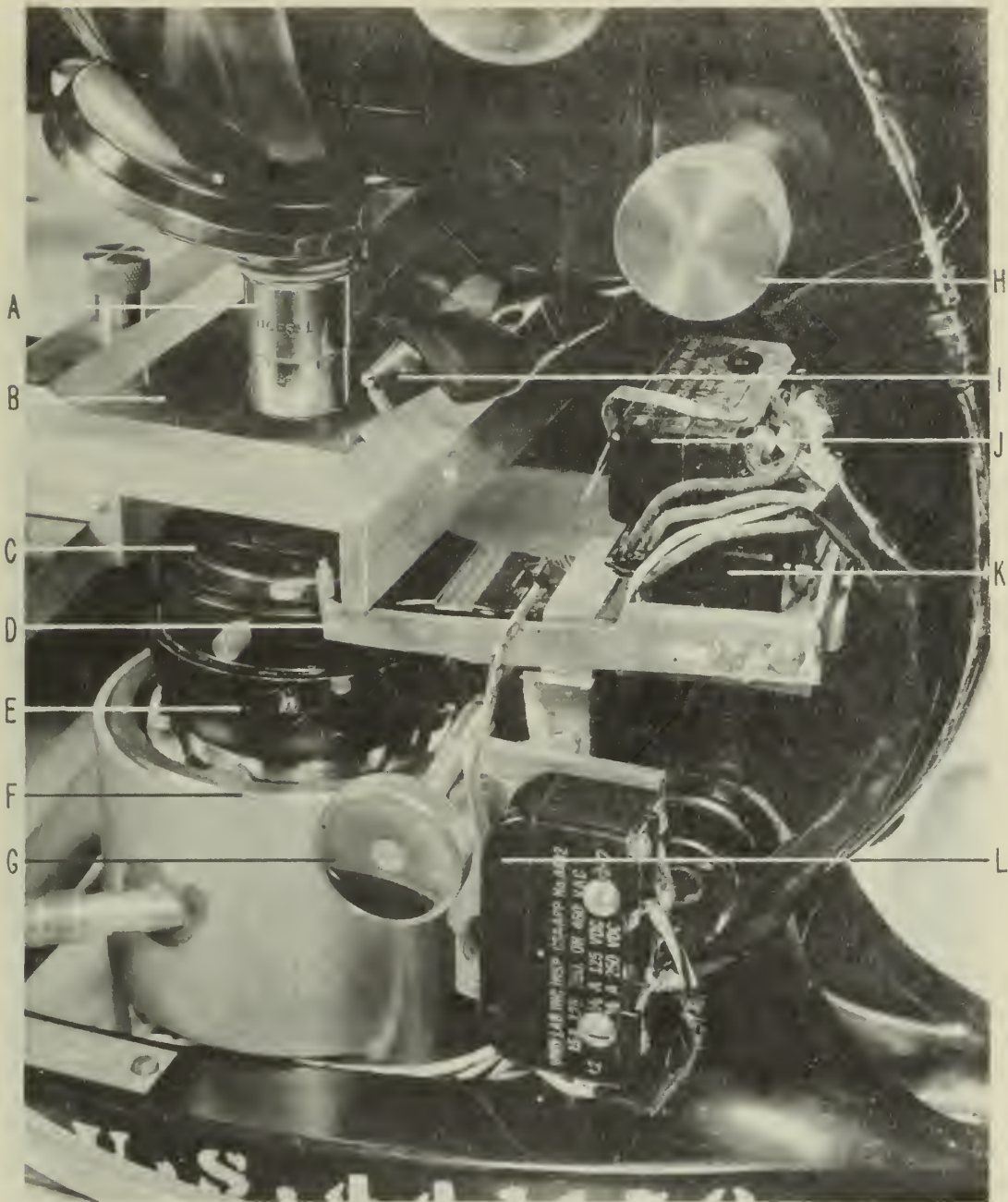

ZN-1294

Fig. 13 Components of dark-field modulation system and scanning-circuit microswitches.

(A) Microscope objective. (B) Photographic plate. (C) Substage condenser. (D) Upper transverse limit microswitch actuating lever. (E) Dark-field stop and analyzer polaroid housing. (F) Air turbine for polarizer. (G) Substage condenser-focusing adjustment. (H) Microscope fine-focusing adjustment. (I) Phase reference photocell. (J) Lower transverse limit microswitch. (K) Upper transverse limit microswitch. (L) Lower-limit safety microswitch.



Fig. 11

Fig. 11. Composite of six photographs showing various stages of a biological specimen, possibly a larva or insect, under a microscope. The images are arranged in a 2x3 grid. The top-left image shows a close-up of a head-like structure with antennae. The top-right image shows a similar structure with a different orientation. The middle-left image shows a more complex, segmented structure. The middle-right image shows a similar structure with a different orientation. The bottom-left image shows a structure with a distinct, rounded, bulbous part. The bottom-right image shows a structure with a distinct, rounded, bulbous part, similar to the bottom-left image but with a different orientation.

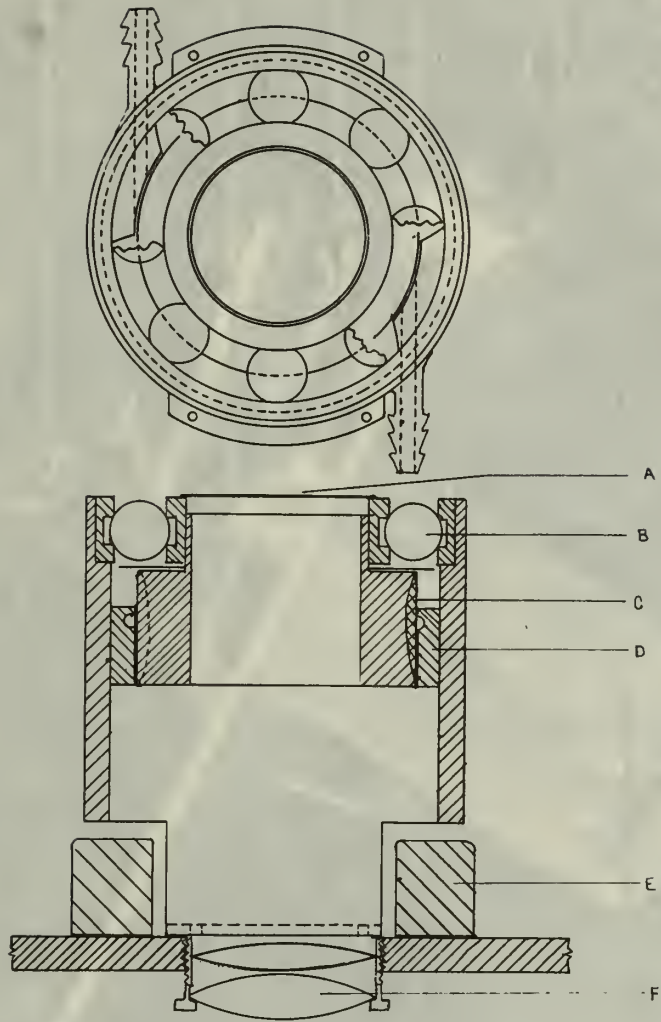

MU-9866

Fig. 14 Air turbine and modulator.

- A. Polarizer
- B. Ball bearing
- C. Turbine rotor
- D. Turbine stator
- E. Legs of microscope stand fork
- F. Collimating lens

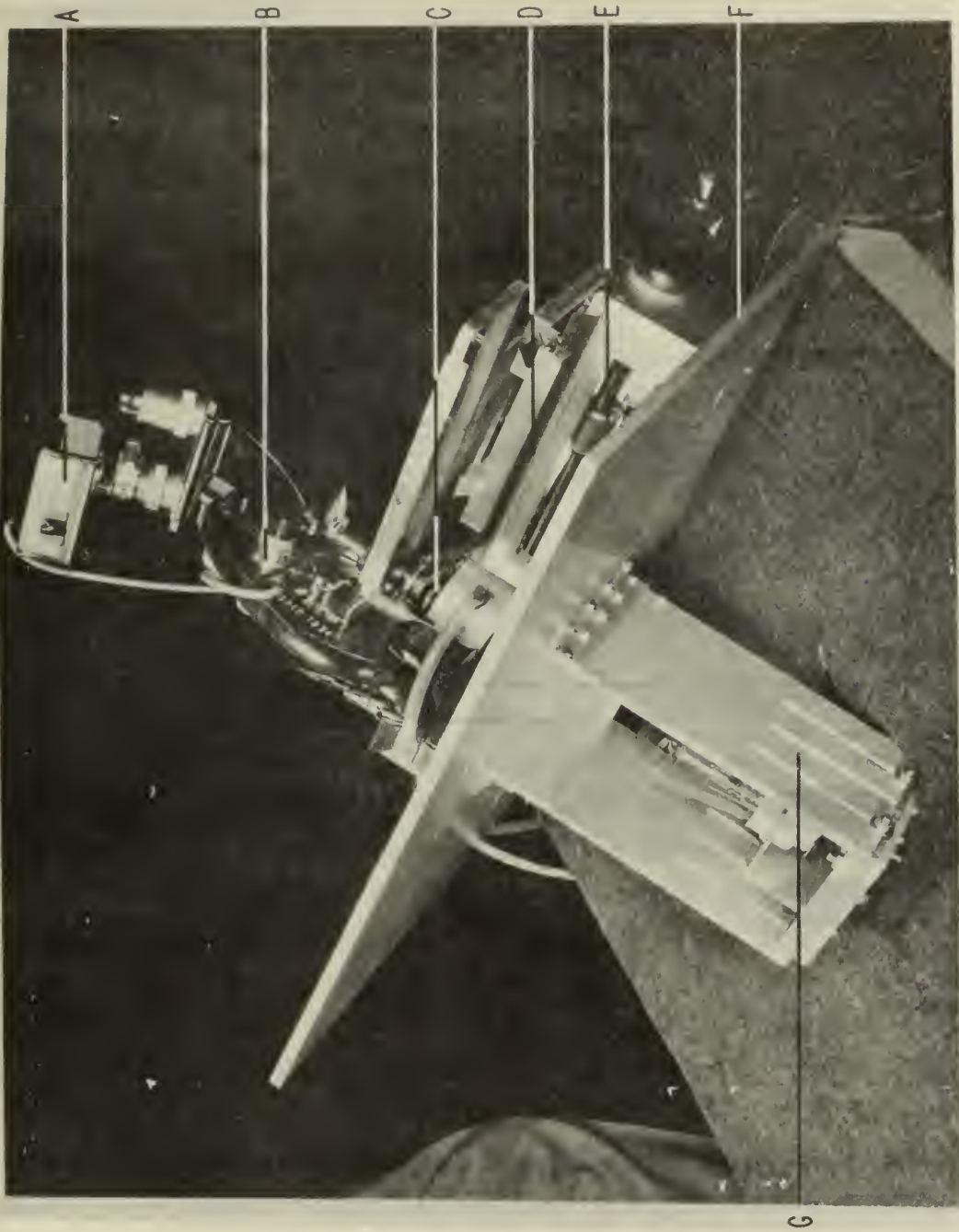

Fig. 15 Alpha-track counter, bottom view.
(A) Photomultiplier housing. (B) Microscope. (C) Dark-field
adapter and modulation system. (D) Scanner. (E) Scanner carriage
split nut. (F) Base plate. (G) Light-source housing.

ZN-1295



THE UNIVERSITY OF CALIFORNIA LIBRARY
UNIVERSITY OF CALIFORNIA LIBRARY
400 TOWN HALL
BERKELEY, CALIF. 94720
TEL. 841-5000
WWW.LIBRARY.UCALIF.EDU

...the light rays ...

The ...

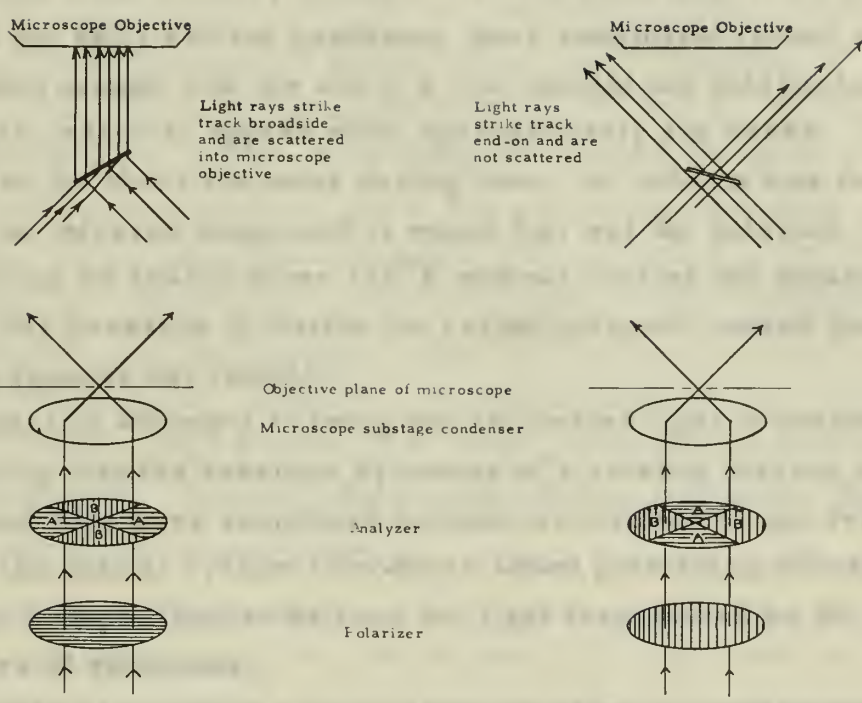

MU-9867

Fig. 16 Polaroid modulation system and light scattering from track.

a 18,000-rpm rotation of the polarizer produces a 600 cps signal at the photomultiplier.

The analyzer was made by very accurately cutting four quadrants from sheet polaroid and laminating them between two optically flat glass disks, using Canada balsam for a bonding agent. Considerable difficulty was encountered with small air bubbles working in between the quadrants as the Canada balsam hardened. Only a few ounces of pressure could be applied to squeeze the glass together or else the quadrants would slide radially outward. It was found that if the bubbles were worked out daily and the quadrants were readjusted (under a low-power microscope with the aid of a fine needle) the balsam hardened and bubbles ceased to appear after approximately six weeks. In order to attain the short six-week drying time, the balsam was dried by means of an infrared lamp until it would just wet the polaroid. The balsam could not be heated above 150°F without causing the polaroid to curl, and any pressure to flatten the curled polaroid caused the quadrants to squeeze out radially.

Unsuccessful attempts to bring the collimated light in horizontally and deflect it up into the substage by means of a rotating mirror coated with a polaroid film were abandoned because an attempt to use reflection anywhere in the optical system introduces added polarizing effects, which render it impossible to balance the light transmitted by the two different pairs of quadrants.

Dark-field illumination was achieved by using a circular dark-field stop 0.959 inch in diameter, supported in the plane of the substage condenser iris by the same bracket that holds the analyzer. The centering of the stop must be perfect, and is set by closing down the iris until the leaves are all just tangent to the periphery of the stop. This can be viewed with a considerable magnification by looking downward through the microscope objective. A 1.4 N. A. Bausch and Lomb substage condenser was modified by removing the upper element of the lens system to increase its focal length so as to permit its use with the photographic plate, which is 1/16 inch thick.

The determining factor for the time required for the instrument to count a complete photographic plate varies inversely as the modulation

frequency of the light. This is because the width of the ocular slit is fixed by other considerations, and at least five cycles of the signal must be generated as the track passes under the ocular slit. It would be highly desirable to increase the tracking rate by a factor of 100 so that the time required to scan the entire plate could be reduced from two days to a few hours. The only limit to the speed with which the plate can be scanned is the ability to modulate a suitable light source at a higher frequency. The use of a Kerr cell to act as a polarizer was considered, but because of the difficulty and unreliability of this device over a long period of use, it was decided to achieve satisfactory operation at lower frequencies before further experimentation. The use of four pulsed lights or arcs was considered, but no satisfactory source was found that possessed all the requirements mentioned above and could still be pulsed on and off at any appreciable frequency. The use of a "flying spot" television tube was considered, but since the spot would be required to traverse the same circle repeatedly, it was calculated that the phosphor would burn off after several hours' operation at the intensity required. No glow-discharge or "strob" light of sufficient intensity was found. The use of toothed gears as mechanical shutters was considered and appears promising, but remains to be further investigated.

3. Optical Signal Generation.

In order to understand the interaction of the polarizer and analyzer and the polarizing effect of the binocular microscope prisms it is helpful to consider a mathematical analysis of the signal.

Let θ equal the variable angle between the direction of polarization of the polarizer and the direction of polarization of the "A" analyzer quadrants. Let α equal the fixed angle between the direction of polarization of the "A" quadrants and the direction of polarization of the microscope prisms. Since the microscope prisms do not completely polarize the light, let k equal the fraction of light polarized by the prisms.

The intensity of the light passing through the polarizer and the "A" quadrants will be proportional to $\cos^2 \theta$, and the intensity of the light passing through the "B" quadrants will be proportional to

$\sin^2 \theta$. The intensity of the light passing through the polarizer, the "A" quadrants, and the prism will be proportional to $\cos^2 \theta (1 - k \sin^2 a)$, and that through the polarizer, the "B" quadrants, and the prism will be $\cos^2 (\theta + \pi/2) \left[1 - k \sin^2 (a + \pi/2) \right]$. The total light intensity will be proportional to the sum of these two factors:

$$\begin{aligned} & \cos^2 \theta (1 - k \sin^2 a) + \cos^2 (\theta + \pi/2) \left[1 - k \sin^2 (a + \pi/2) \right] \\ &= \cos^2 \theta - k \cos^2 \theta \sin^2 a + \sin^2 \theta - k \sin^2 \theta \cos^2 a \\ &= 1 - k (\sin^2 a \cos^2 \theta + \cos^2 a \sin^2 \theta). \end{aligned}$$

If the total light intensity is to remain constant as the polarizer is rotated (θ is varied), the expression must be independent of θ . It is independent only if $a = 45^\circ$, which reduces the expression to

$$1 - \frac{k}{2}.$$

The instrument therefore is constructed with $a \approx 45^\circ$, to prevent this unwanted modulation. A slight amount of this prism modulation, however, is useful in canceling small imbalances due to slight optical misalignment in the intensities of light passing through the two pairs of quadrants. The amount of prism modulation necessary to compensate the imbalances is achieved by rotating the analyzer two or three degrees.

DESIGN OF THE ELECTRONIC SYSTEM

1. The Photomultiplier and Tuned Amplifier.

A specially selected type 1P21 photomultiplier tube was utilized for the task of converting the minute optical signal into an electrical signal that could be handled by the subsequent electronic circuitry. Its extremely high gain, 2×10^6 , and a low dark current and noise output made it the best available tube for the difficult task. Refer to Fig. 17 for a schematic diagram of the entire electronic system, and Figs. 18 and 19 for photographs of typical waveforms. A 600-cps signal, 60 mv peak to peak with a signal-to-noise ratio at 10, appears across R11. If R11 is bypassed with a 0.2-mfd condenser, the high-frequency components of the noise are removed and the oscilloscope presentation becomes quite useful for alignments to the optical system. This condenser was originally included in the circuit, but was discarded because it decreased the frequency response of the amplifier to the signal frequency by a factor of 2, and the tuned amplifier effectively removes the noise. The test relay is a provision for introducing a test signal from an oscillator. The relay is triggered by the external trigger circuit of an oscilloscope in such a fashion that only five cycles of the oscillator voltage are allowed to enter the amplifier during each scan of the scope. This provides a very convenient method for testing and aligning all the electronic circuits. The output from the tuned amplifier is approximately 5 volts peak to peak. The tuned amplifier has a gain of 500 for a frequency of 600 cps.

2. Phase-Reference Voltage Circuit.

The phase-reference voltage is generated by the 1P41 photocell mounted on the microscope in such a position that it accepts the light from the "broadside" quadrants of the substage just above the microscope objective. The phase amplifier provides a voltage gain of 600 for the phase input signal and a variable phase which can be adjusted through 180° by R74. The frequency of the amplified voltage is doubled by an interstage transformer which acts upon the grids of VT21, causing the tube to conduct current alternately through R106 and R107, thereby

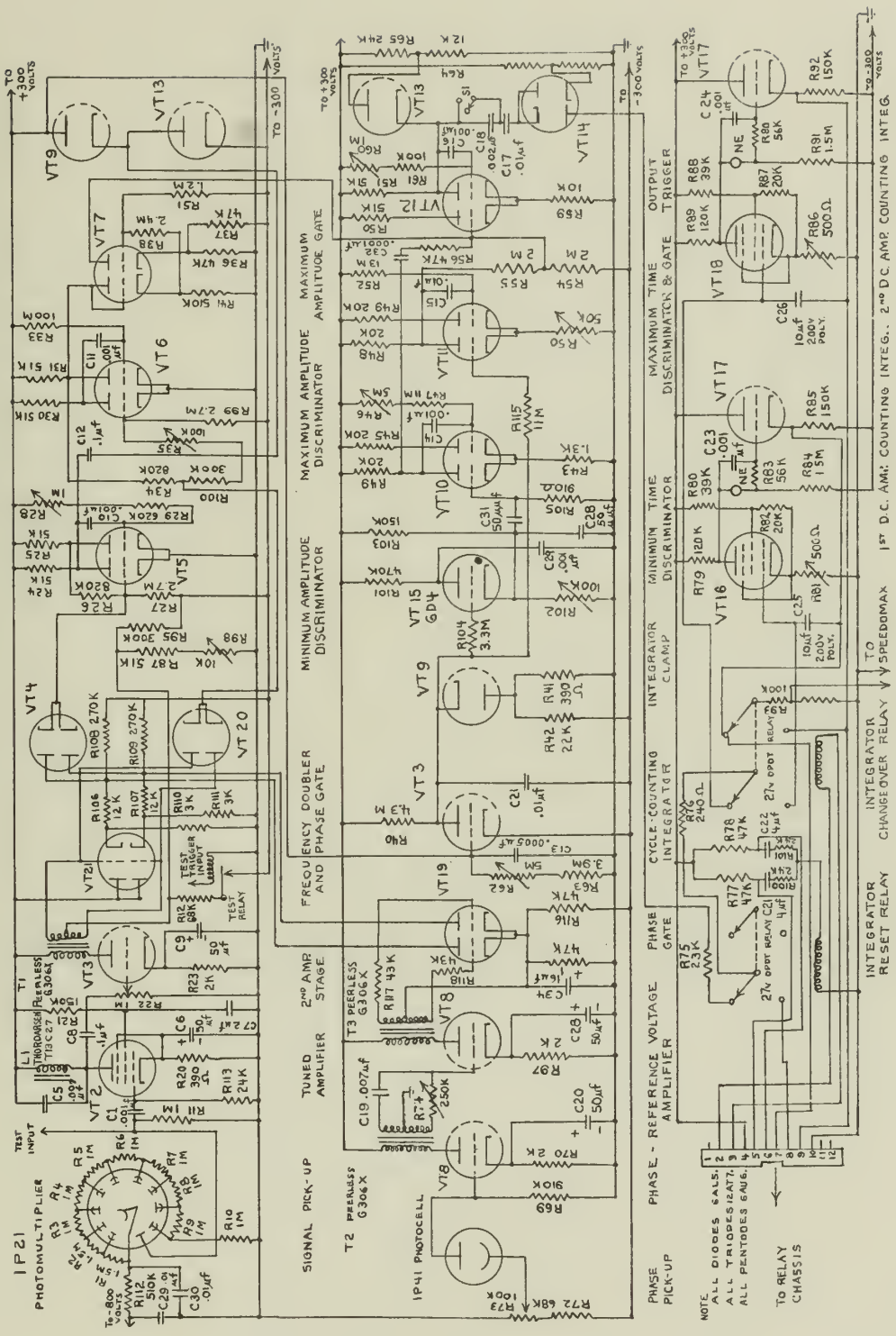
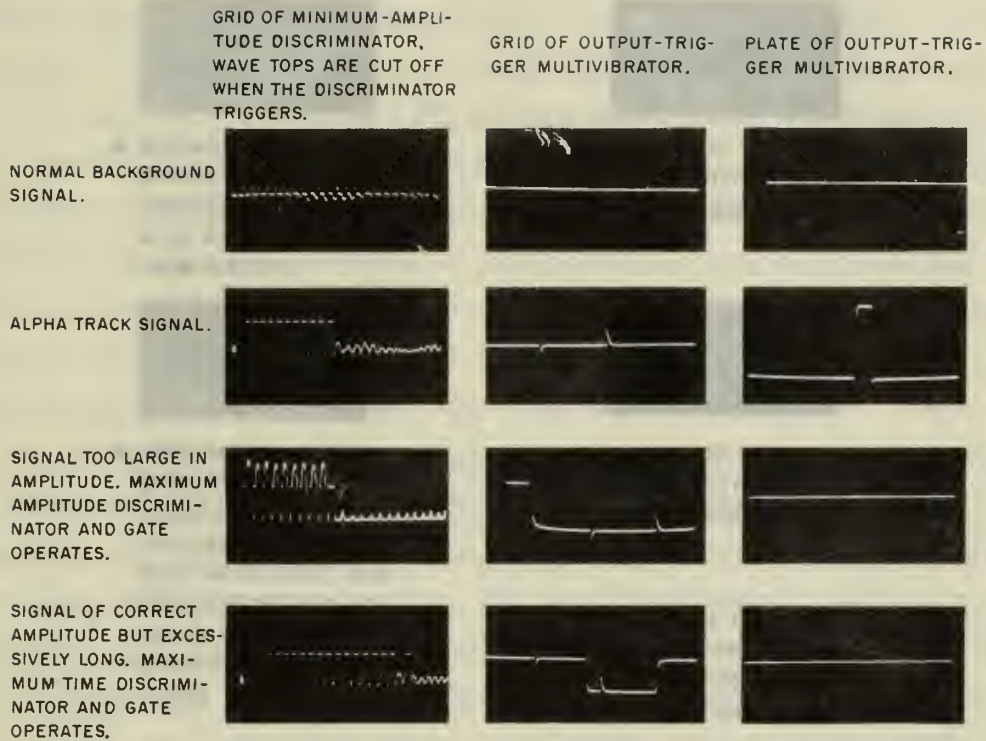



Fig. 17 Schematic of the electronic system.



MU-9868

Fig. 18 Normal electronic waveforms .

Experiment 1	Experiment 2	Experiment 3	
			Experiment 1, 2, 3
			Experiment 1, 2, 3
			Experiment 1, 2, 3
			Experiment 1, 2, 3

Experiment 1, 2, 3



A. NORMAL BACKGROUND SIGNAL THAT RARELY TRIGGERS THE MINIMUM AMPLITUDE DISCRIMINATOR.



C. SIGNAL OF UNCORRECT PHASE WITH THE PHASE GATE INOPERATIVE.



B. TROUBLESOME BACKGROUND SIGNAL THAT CAUSES INTERMITTENT TRIGGERING OF MINIMUM AMPLITUDE DISCRIMINATOR RESULTING IN OCCASIONAL SPURIOUS OUTPUT PULSE.



D. SIGNAL OF INCORRECT PHASE WITH THE PHASE GATE OPERATIVE.

HORIZONTAL LINE INDICATES THE TRIGGERING LEVEL OF THE MINIMUM AMPLITUDE DISCRIMINATOR.

MU-9869

Fig. 19 Special electronic waveforms .

providing a high bias voltage on the diodes of VT4. R98 sets the triggering level of the minimum-amplitude discriminator by adjusting the grid bias, thus preventing it from operating unless the signal from the track and the signal from the reference voltage system are in phase.

3. The Discriminator Circuits.

The diodes of VT4 also act as a clamp for the bias of the minimum amplitude discriminator, thereby providing a definite and reliable level at which the discriminator will operate. The minimum-amplitude discriminator is a trigger circuit with a time constant arranged so that the recovery time is less than the time between every other pulse of the input signal. The negative output of this discriminator is impressed upon the grid of the second half of VT3 through the diode VT9. The recovery time of the RC combination connected to the grid of VT3 is adjusted so that the grid voltage fails to recover sufficiently to place the tube in conduction before the next pulse in the consecutive train from the minimum-amplitude discriminator again drives the grid far below cutoff. As long as the grid voltage remains below cutoff, the plate voltage is free to rise at a rate that depends upon the values of C21 and R40. This voltage rise is approximately linear over the range utilized and is equal to 5 volts per millisecond. In the absence of two consecutive signals from the minimum-amplitude discriminator the grid of VT3 reaches zero volts, and the tube passes plate current, thereby discharging C21 to -5 volts. The excursion of C21 is determined by the clamping diode VT9. Therefore VT3 acts as a cycle counter which puts out a constantly rising voltage for uninterrupted input signals, and which resets itself when the signals are interrupted, thereby providing a voltage proportional to the length of the pulse train from the minimum-amplitude discriminator.

The output trigger multivibrator can be inactivated by a signal from the maximum-amplitude discriminator, which is a trigger circuit similar to the lower-level discriminator except that it is biased to trigger at a higher level of the same signal that triggers the minimum-amplitude discriminator. If the input signal is too large to have been generated by a single track, the maximum-amplitude discriminator causes VT7 to conduct, thus biasing the grid of the output-trigger tube and preventing its operation.

When ten uninterrupted signals to the cycle counter occur from

a normal alpha track's passage under the ocular slit, the output from the cycle-counting integrator rises to 25 volts and is sufficient to trigger the multivibrator used to provide minimum-time discrimination. This multivibrator utilizes V10T and is designated as the minimum-time discriminator. The output of V10T is differentiated across C15 and R56, providing a positive trigger pulse for the output-trigger tube V12T from its trailing edge. If the output of the cycle-counting integrator rises above 45 volts, corresponding to 16 uninterrupted pulses from the minimum-amplitude discriminator, the maximum-time discriminator VT11 is actuated. When the maximum-time discriminator is triggered, the grid of V12T is pulled considerably negative, preventing the trigger pulse from V10T from actuating it. V10T has an output pulse sufficiently long that the trailing edge has not yet fired V12T at the time it can be gated off by V11T. Thus the output-trigger circuit is actuated when the input signal is large enough, but not too large; continues long enough, but not too long; and is in the proper phase with respect to the reference voltage.

4. The Counting Integrators.

The output signal from the output-trigger circuit is fed into one of two identical electronic integrating circuits which perform the function of actually counting the alpha tracks. Their output voltage is proportional to the number of input pulses received during the course of one complete strip. One of the integrators receives the input pulses while the output of the other is connected to the Speedomax recorder. After the first integrator has totaled the pulses from one strip on the photographic plate, the integrator change-over relay switches the input pulses to the second integrator, resets it, and connects the Speedomax to the output of the first integrator. The integrator reset relay resets the integrator attached to the output-trigger circuit at the start of each strip by a signal from the scanning system.

The quantity of charge associated with each input pulse to the integrator is determined by the charge on C17, and this charge in turn is determined by the voltage excursion of the plate of V12T and the capacity of C17. The condenser is charged through one-half of the twin diode VT14 to 300 volts, and discharges through the other half of the diode down

to 100 volts, as determined by the clamp VT13. Hence the amount of charge transferred to the integrator with each pulse is accurately determined and is completely independent of the wave shape at the plate of V12T. The switch at the input to the integrator places C18 in series with C17 to provide a low-sensitivity range when it is needed. The output of the integrator is 100 volts for 500 pulses on the normal range and 100 volts for 3000 on the low-sensitivity range. The output of the integrator is divided by a ratio of 1 to 10,000 across R93 and R94 to provide a maximum voltage of 10 millivolts for the full-scale deflection of the Speedo-max recorder.

ERRORS IN COUNTING

1. Statistics of the Counter.

The design of the electronic discriminators allows the instrument to count parallel tracks of purely random distribution but having a constant average density for a given strip; only one configuration of tracks causes a statistical error. This configuration is two or more tracks with more than half their lengths appearing in the ocular slip simultaneously, and is illustrated in Case a of Fig. 20. The maximum-time discriminator transmits a blanking signal and the instrument therefore counts neither track although it should record both. Considering the configuration of Case b, we find two tracks in the same straight line, each with less than half its length in the slit but with a combined length of more than half a track in the slit. It will be observed that the instrument records one extra count, because the left-hand track has already been counted in the previous strip and the right-hand track is going to be counted in the next strip. This configuration is statistically rare, however, and in any event the configuration of Case c has an equal probability of occurring and introduces an error of minus one count, so that the net statistical error is zero for the two cases. Any other configuration that may occur will be correctly handled by the electronic discriminators. For example, in Case d, Track A is counted in Strip 1, Track B in Strip 2, and Track C in Strip 3. In Case e, Track A is counted in Strip 1, Track B in Strip 2, Track C in Strip 3, and Track D is not counted at all because the phase discriminator does not permit the amplifier to transmit its signal.

A first-order correction for the statistical error may be computed because the tracks in any given strip appear with completely random distribution but with a constant average density, so that the Gaussian distribution function will apply. Let N be defined as the total number of tracks in a given strip, w as the optical width of the ocular slit, $\langle d \rangle$ as the mean distance between the tracks in the strip, l as the length of the strip, and P as the probability of two adjacent tracks

Small amount of ...

...

The number of ...

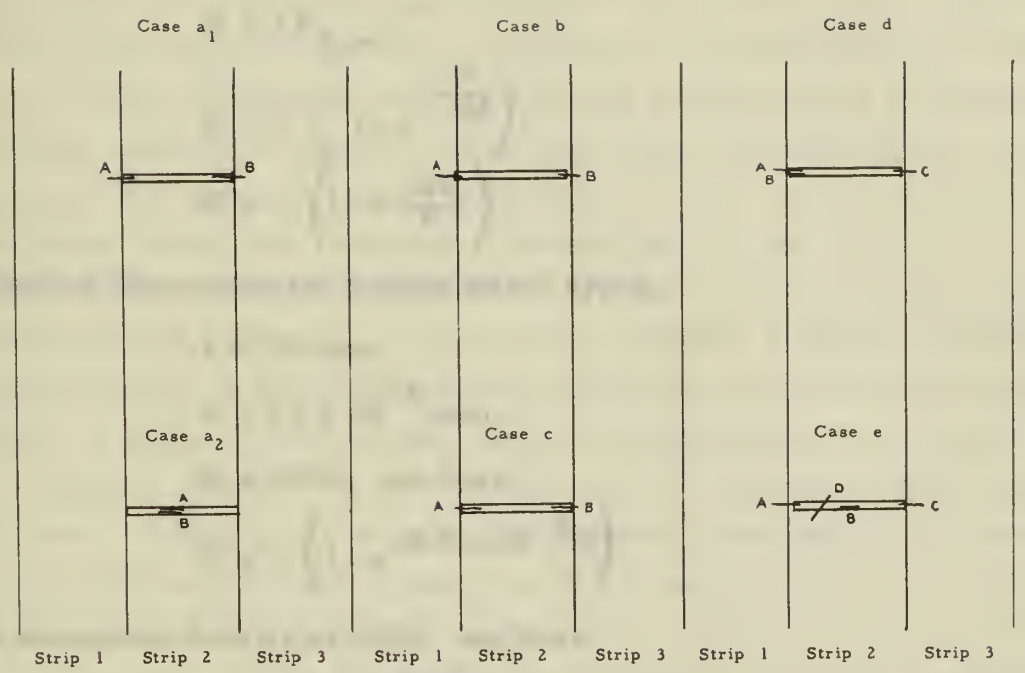

MU-9870

Fig. 20 Statistical grouping of tracks in the slit.

The ...

being separated by a distance greater than d_1 but less than d_2 . Then, according to the Gaussian integral,

$$P_{d_1, d_2} = e^{-\frac{d_1}{\langle d \rangle}} - e^{-\frac{d_2}{\langle d \rangle}}.$$

The number of pairs of tracks that will not be counted is equal to the product of N and the probability of two adjacent tracks' having a separation of less than w . The relative error E for a given strip is

$$E = 2 P_{0, w},$$

$$E = 2 \left(1 - e^{-\frac{w}{\langle d \rangle}} \right),$$

$$E = 2 \left(1 - e^{-\frac{wN}{l}} \right).$$

Substituting the numerical values which apply,

$$l = 50 \text{ mm},$$

$$w = 25 \times 10^{-4} \text{ mm},$$

$$N = 2000, \text{ we have}$$

$$E = 2 \left(1 - e^{-0.5 \times 10^{-5} N} \right).$$

For a maximum density of 2000; we have

$$E = 2 \left(1 - e^{-0.1} \right),$$

$$E = 20\%.$$

2. Systematical Errors.

There are many sources of error in the actual operation of the instrument that are not statistical in nature. In actual practice the instrument counts about 60% of the tracks in a given scan across the photographic plate. If the plate is reasonably clean and free from dust and scratches, about 100 spurious pulses per scan will pass all the criteria and be counted as tracks. Several factors operate together to cause a bona fide track to be missed during the scan. About 20% of the tracks produce a signal of appreciably smaller amplitude than normal. In order

to reject spurious signals the minimum amplitude discriminator must be set to such a level that it is not reliably triggered by these tracks. Tracks that produce a signal of normal amplitude may be missed when electronic noise causes the minimum amplitude discriminator to miss two adjacent cycles, thereby preventing the integrator from reaching the minimum time level. This electronic noise may also cause two or more extra pulses at the end of a normal pulse train from a track, allowing the integrator to reach the maximum time level, resulting in the signal's being blocked by the maximum-time gate. The majority of the spurious output pulses are caused by dust particles and pinholes in the emulsion. A rather wide channel between the minimum and maximum time discriminators is required because noise causes the same track to produce a pulse train varying in length by 25%, and different tracks on the same plate cause this pulse variation to increase to 40%. The time discriminators must accept this variation if the majority of the tracks are to be counted, so they become less effective in discriminating against signals originating from pinholes or small dust particles. A similar difficulty is experienced with the amplitude discriminators, which must accept a variation of 20% in order for the majority of the tracks to be counted. A few spurious signals are generated by areas of emulsion that appear to be clear. These areas trigger the minimum amplitude discriminator in such a fashion that pulse trains varying in length from two to fifty pulses are produced continually as the area is scanned. Some of the pulse trains pass all the discrimination criteria and produce spurious output pulses. Fortunately the areas are rare and usually less than mm in diameter. Refer to Fig. 19 for a typical wave form and produced by troublesome background. Several areas for improvement are indicated. The signal-to-noise ratio at the amplifier could be improved by increasing the intensity of the light source and using a monocular microscope with a removable prism for alignment. Spurious counts could be largely eliminated with greater care in the developing and handling of the photographic plates. A small rotating mechanical shutter might replace the polaroid modulator, increasing the light transmission and providing an output signal with a phase angle proportional to the direction of the object producing the signal, but it would not have the tolerance to vibration inherent in the polaroid modulator.

At its present stage of development the instrument will give good results in areas with densities greater than 200 tracks per scan. Development of the instrument is being continued along the lines indicated above to improve its performance and reliability.

BIBLIOGRAPHY

1. H. Seidentopf, Z. wiss. Mikroskop., 29, 1 (1912).
2. F. Weigert, Optische Methoden der Chemie, p. 412-417.
(Akademische Verlagsgesellschaft M. B. H.) Leipzig, 1927.
3. E.H. Land, G. Bird and W.A. Shurcliff, J. Opt. Soc. Am.,
40, 61 (1950)
4. F.L. Reynolds, Rev. Sci. Instruments 22, 749 (1951)
5. F. Asaro, F.L. Reynolds and I. Perlman, Phys. Rev. 87, 227
(1952)

Information Division
6/28/55 jm

Thesis

28476

T79

Treadwell
The alpha-track
counter.

28476

Thesis

T79

Treadwell
The alpha-track counter.

thesT79

The alpha-track counter.



3 2768 002 03633 7
DUDLEY KNOX LIBRARY